

UNITED STATES PATENT AND TRADEMARK OFFICE

BEFORE THE PATENT TRIAL AND APPEAL BOARD

COOLIT SYSTEMS, INC.,

Petitioner,

v.

ASETEK DANMARK A/S,
Patent Owner.

IPR2021-01196
Patent 10,599,196 B2

Before MICHAEL P. TIERNEY, *Vice Chief Administrative Patent Judge*,
KEVIN W. CHERRY, and JASON W. MELVIN,
Administrative Patent Judges.

MELVIN, *Administrative Patent Judge*.

DECISION
Granting Institution of *Inter Partes* Review
35 U.S.C. § 314

I. INTRODUCTION

CoolIT Systems, Inc. (“Petitioner”) filed a Petition (Paper 1, “Pet.”) requesting institution of *inter partes* review of claims 1–19 of U.S. Patent No. 10,599,196 B2 (Ex. 1001, “the ’196 patent”). Asetek Danmark A/S (“Patent Owner”) filed a Preliminary Response (Paper 6, “Prelim. Resp.”). In the Preliminary Response, Patent Owner notes that it has disclaimed claims 3–19. Prelim. Resp. 3; Ex. 2008. Thus, claims 1 and 2 remain at issue (the “challenged claims”). We authorized Petitioner to file a Preliminary Reply (Paper 7, “Prelim. Reply”) and Patent Owner to file a Preliminary Sur-reply (Paper 8, “Prelim. Sur-reply”). Pursuant to 35 U.S.C. § 314 and 37 C.F.R. § 42.4(a), we have authority to determine whether to institute review.

An *inter partes* review may not be instituted unless “the information presented in the petition . . . and any response . . . shows that there is a reasonable likelihood that the petitioner would prevail with respect to at least 1 of the claims challenged in the petition.” 35 U.S.C. § 314(a). For the reasons set forth below, we conclude that Petitioner has shown a reasonable likelihood it will prevail in establishing the unpatentability of at least one challenged claim, and we institute *inter partes* review.

A. REAL PARTIES IN INTEREST

The Petition identifies CoolIT Systems, Inc. as the real party-in-interest for Petitioner. Pet. 94. Patent Owner identifies Asetek Danmark A/S, Asetek USA, Inc., Asetek A/S, and Asetek Holdings, Inc. as the real parties-in-interest for Patent Owner. Paper 4, 1 (Patent Owner’s Mandatory Notices).

B. RELATED MATTERS

The parties identify *Asetek Danmark A/S v. CoolIT Systems, Inc.*, Case No. 3:19-cv-00410-EMC (N.D. Cal.) (filed on January 23, 2019, currently pending); *Asetek Danmark A/S v. Corsair Gaming, Inc.*, Case No. 3:20-cv-06541-EMC (N.D. Cal.) (filed on September 17, 2021, currently pending); and *Asetek Danmark A/S v. Shenzhen Apaltek Co.*, Case No. 6:21-cv-00501 (W.D. Tex.) (filed on May 14, 2021, currently pending) as the related co-pending district-court litigations. Pet. 95; Paper 4, 1. Petitioner also identifies the following pending petitions for *inter partes* review involving patents that are related to the '196 patent: IPR2020-00522 (No. 10,078,355 B2, filed February 7, 2019); IPR2020-00523 (No. 10,078,354 B2, filed February 7, 2020); IPR2020-00524 (No. 9,933,681 B2, filed February 7, 2020); and IPR2021-01195 (No. 10,613,601, filed concurrently). Pet. 95.

C. THE '196 PATENT

The '196 patent is titled “Cooling System for a Computer System.” Ex. 1001, code (54). It issued from an application filed May 29, 2018, as a continuation of application No. 15/626,706, which issued as Patent No. 10,078,355 (“the '355 patent”) and claims priority to a PCT application filed May 6, 2005, now abandoned. *Id.*, code (63).

The '196 patent relates to a liquid-cooling system for a computer system. *Id.*, code (57). The specification explains, at the time of the invention, air cooling arrangements were the most-used cooling system for cooling central processing units (CPUs) in computer systems. *Id.* at 1:24–:31. An alternative design known at the time of the invention was to use a cooling liquid circulating inside a closed system by means of a pumping unit with a heat exchanger past which the cooling liquid circulates. *Id.* at 1:38–

:42. The specification contends that liquid cooling is generally more efficient and quieter than air cooling, but that a liquid cooling design consists of “many components,” which increases the total installation time, size, and risk of leakage of the cooling liquid from the system. *Id.* at 1:43–:48. Thus, one object of the invention is to provide a small and compact liquid-cooling solution that is more efficient than existing air-cooling arrangements and is produced at low cost, enabling high production volumes. *Id.* at 1:56–:63. Another object of the invention is to create an arrangement which is easy-to-use and implement, used with existing CPU types and computer systems, and requires a low level of maintenance or no maintenance at all. *Id.* at 1:63–:67.

An illustrative embodiment of such a device is depicted in Figures 7 and 8, reproduced below.

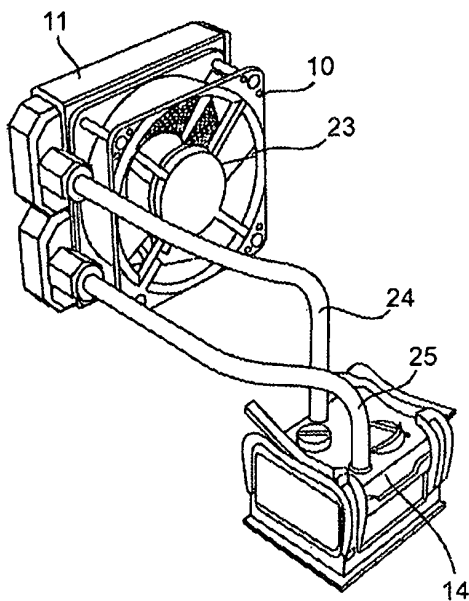

FIG. 7

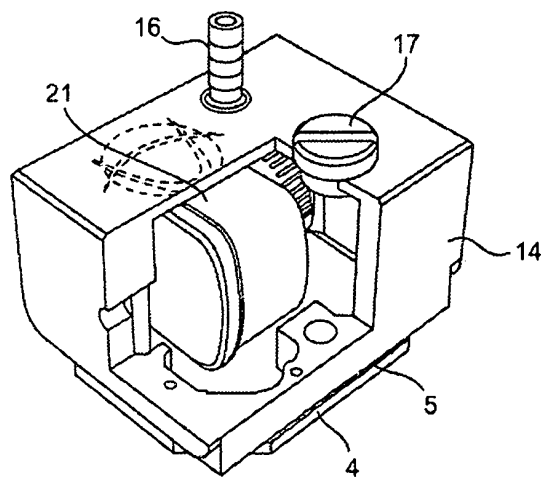

FIG. 8

Figure 7¹ is a perspective view of the cooling system showing reservoir housing 14 with the heat exchanging surface 5 (shown in Figure 8) and the pump 21 (shown in Figure 8) inside the reservoir. *Id.* at 16:18–:21. Figure 8 is a cut-out view into reservoir housing 14, when the reservoir, pump 21, and heat exchanging surface 4 are situated inside the reservoir. *Id.* at 15:50–:52. The reservoir has a tube inlet connection (not shown in Figure 8) through which the cooling liquid enters the reservoir. *Id.* at 15:52–:57. From the tube inlet connection, the cooling liquid flows through the reservoir passing heat exchanging surface 4 and enters the inlet of the pump. *Id.* at 15:55–:57. After the cooling liquid flows through the pump, the cooling liquid passes out of the outlet of the pump and further out through tube outlet connection 16. *Id.* at 15:57–:59. As shown in Figure 7, tube inlet connection and tube outlet connection 16 are connected to heat radiator 11 by means of connecting tubes 24 and 25. *Id.* at 16:21–:23. Cooling liquid flows into and out of the reservoir and the heat radiator through connecting tubes 24 and 25, respectively. *Id.* at 16:23–:25. Heat radiator 11 (shown in Figure 7) cools the cooling liquid before it passes back into the reservoir. *Id.* at 16:25–:32.

The reservoir may be provided with channels or segments for establishing a certain flow-path for the cooling liquid through the reservoir to prevent the cooling liquid passing the reservoir too quickly to take up a sufficient amount of heat from the heat exchanging surface. *Id.* at 16:51–:64.

¹ We agree with Petitioner that it appears that the specification transposes the description of Figure 7 with that of Figure 8. Pet. 5 n.1. We refer to the description of “Figure 8” in the specification in our discussion of Figure 7, and we refer to the specification’s discussion of “Figure 7” in our discussion of Figure 8.

Explore Litigation Insights

Docket Alarm provides insights to develop a more informed litigation strategy and the peace of mind of knowing you're on top of things.

Real-Time Litigation Alerts



Keep your litigation team up-to-date with **real-time alerts** and advanced team management tools built for the enterprise, all while greatly reducing PACER spend.

Our comprehensive service means we can handle Federal, State, and Administrative courts across the country.

Advanced Docket Research



With over 230 million records, Docket Alarm's cloud-native docket research platform finds what other services can't. Coverage includes Federal, State, plus PTAB, TTAB, ITC and NLRB decisions, all in one place.

Identify arguments that have been successful in the past with full text, pinpoint searching. Link to case law cited within any court document via Fastcase.

Analytics At Your Fingertips



Learn what happened the last time a particular judge, opposing counsel or company faced cases similar to yours.

Advanced out-of-the-box PTAB and TTAB analytics are always at your fingertips.

API

Docket Alarm offers a powerful API (application programming interface) to developers that want to integrate case filings into their apps.

LAW FIRMS

Build custom dashboards for your attorneys and clients with live data direct from the court.

Automate many repetitive legal tasks like conflict checks, document management, and marketing.

FINANCIAL INSTITUTIONS

Litigation and bankruptcy checks for companies and debtors.

E-DISCOVERY AND LEGAL VENDORS

Sync your system to PACER to automate legal marketing.