

UNITED STATES PATENT AND TRADEMARK OFFICE

BEFORE THE PATENT TRIAL AND APPEAL BOARD

CISCO SYSTEMS, INC.,
Petitioner,

v.

TQ DELTA, LLC,
Patent Owner.

Case IPR2016-01021
Patent 8,718,158 B2

Before SALLY C. MEDLEY, KALYAN K. DESHPANDE, and
TREVOR M. JEFFERSON, *Administrative Patent Judges*.

MEDLEY, *Administrative Patent Judge*.

DECISION
Institution of *Inter Partes* Review
37 C.F.R. § 42.108

I. INTRODUCTION

Cisco Systems, Inc. (“Petitioner”) filed a Petition requesting an *inter partes* review of claims 1–30 of U.S. Patent No. 8,718,158 B2 (Ex. 1001, “the ’158 patent”). Paper 2 (“Pet.”). TQ Delta, LLC (“Patent Owner”) filed a Preliminary Response. Paper 6 (“Prelim. Resp.”). Institution of an *inter partes* review is authorized by statute when “the information presented in the petition . . . and any response . . . shows that there is a reasonable likelihood that the petitioner would prevail with respect to at least 1 of the claims challenged in the petition.” 35 U.S.C. § 314(a); *see* 37 C.F.R. § 42.108. Upon consideration of the Petition and Preliminary Response, we conclude the information presented shows there is a reasonable likelihood that Petitioner would prevail in establishing the unpatentability of claims 1–30 of the ’158 patent.

A. Related Proceedings

Petitioner indicates that the ’158 patent is the subject of several pending judicial matters. Pet. 1.

B. The ’158 Patent (Ex. 1001)

The ’158 patent relates to multicarrier communications systems that lower the peak-to-average power ratio (PAR) of transmitted signals. Ex. 1001, 1:28–31. A value is associated with each carrier signal, and a phase shift is computed for each carrier signal based on the value associated with that carrier signal. *Id.* at 2:38–41. The value is determined independent of the input bit value carried by the carrier signal. The computed phase shift value is combined with the phase characteristic of that carrier signal to substantially scramble the phase characteristics of the carrier

signals. *Id.* at 2:38–45. Figure 1 illustrates the multicarrier communication system and is reproduced below:

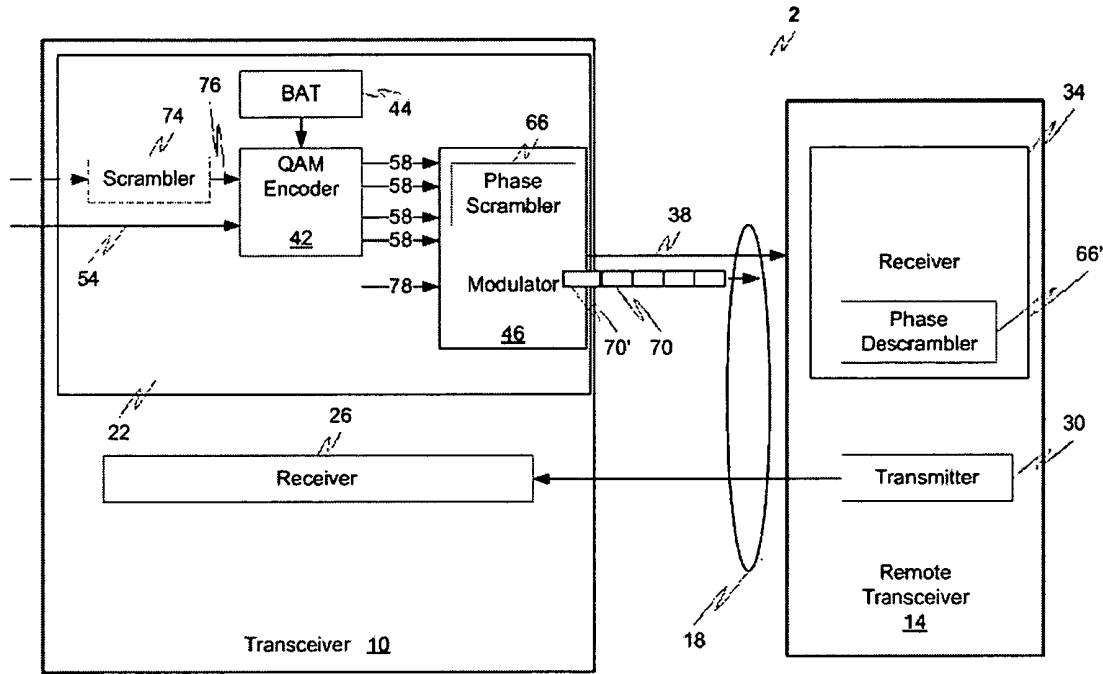

FIG. 1

Figure 1 illustrates the multicarrier communication system, digital subscriber line (DSL) communication system 2, which includes discrete multitone (DMT) transceiver 10 communicating with remote transceiver 14 over communication channel 18 using transmission signal 38 having a plurality of carrier signals. *Id.* at 3:27–31. DMT transceiver 10 includes DMT transmitter 22 and DMT receiver 26. *Id.* at 3:31–32. Remote transceiver also includes transmitter 30 and receiver 34. *Id.* at 3:32–34. DMT transmitter 22 transmits signals over communication channel 18 to receiver 34. *Id.* at 3:40–42.

DMT transmitter 22 includes a quadrature amplitude modulation (QAM) encoder 42, modulator 46, bit allocation table (BAT) 44, and phase

scrambler 66. *Id.* at 3:53–56. QAM encoder 42 has a single input for receiving serial data bit stream 54 and multiple parallel outputs to transmit QAM symbols 58 generated by QAM encoder 42 from bit stream 54. *Id.* at 3:65–4:1. Modulator 46 provides DMT modulation functionality and transforms QAM symbols 58 into DMT symbols 70. *Id.* at 4:12–14. Modulator 46 modulates each carrier signal with a different QAM symbol 58, and, therefore, this modulation results in carrier signals having phase and amplitude characteristics based on QAM symbol 58. *Id.* at 4:15–18. Modulator 46 also includes phase scrambler 66 that combines a phase shift computed for each QAM-modulated carrier signal with the phase characteristics of that carrier signal. *Id.* at 4:31–34.

C. Illustrative Claim

Petitioner challenges claims 1–30 of the '158 patent. Claims 1 and 15 are independent claims. Claims 2–14 and 29 depend, either directly or indirectly, from claim 1, and claims 16–28 and 30 depend, either directly or indirectly, from claim 15. Claim 1 is reproduced below.

1. In a multicarrier modulation system including a first transceiver in communication with a second transceiver using a transmission signal having a plurality of carrier signals for modulating a plurality of data bits, each carrier signal having a phase characteristic associated with at least one bit of the plurality of data bits, a method for scrambling the phase characteristics of the carrier signals comprising:

transmitting the plurality of data bits from the first transceiver to the second transceiver;

associating a carrier signal with a value determined independent of any bit of the plurality of data bits carried by the

carrier signal, the value associated with the carrier signal determined by a pseudo-random number generator;

determining a phase shift for the carrier signal at least based on the value associated with the carrier signal;

modulating at least one bit of the plurality of data bits on the carrier signal; and

modulating the at least one bit on a second carrier signal of the plurality of carrier signals.

Ex. 1001, 10:59–11:11.

D. The Alleged Grounds of Unpatentability

The information presented in the Petition sets forth proposed grounds of unpatentability of claims 1–30 of the '158 patent under 35 U.S.C.

§ 103(a) as follows (Pet. 9–10):¹

References	Claims Challenged
Shively ² and Stopler ³	1, 2, 4, 15, 16, and 18
Shively, Stopler, and Gerszberg ⁴	3, 5, 14, 17, 19, and 28–30
Shively, Stopler, and Bremer ⁵	6, 9, 10, 12, 20, 23, 24, and 26
Shively, Stopler, Bremer, and Gerszberg	8, 11, 13, 22, 25, and 27

¹ Petitioner supports its challenges with the Declaration of Dr. Jose Tellado. Ex. 1009.

² U.S. Patent No. 6,144,696; issued Nov. 7, 2000 (Ex. 1011) (“Shively”).

³ U.S. Patent No. 6,625,219 B1; issued Sept. 23, 2003 (Ex. 1012) (“Stopler”).

⁴ U.S. Patent No. 6,424,646 B1; issued July 23, 2002 (Ex. 1013) (“Gerszberg”).

⁵ U.S. Patent No. 4,924,516; issued May 8, 1990 (Ex. 1017) (“Bremer”).

Explore Litigation Insights

Docket Alarm provides insights to develop a more informed litigation strategy and the peace of mind of knowing you're on top of things.

Real-Time Litigation Alerts



Keep your litigation team up-to-date with **real-time alerts** and advanced team management tools built for the enterprise, all while greatly reducing PACER spend.

Our comprehensive service means we can handle Federal, State, and Administrative courts across the country.

Advanced Docket Research



With over 230 million records, Docket Alarm's cloud-native docket research platform finds what other services can't. Coverage includes Federal, State, plus PTAB, TTAB, ITC and NLRB decisions, all in one place.

Identify arguments that have been successful in the past with full text, pinpoint searching. Link to case law cited within any court document via Fastcase.

Analytics At Your Fingertips



Learn what happened the last time a particular judge, opposing counsel or company faced cases similar to yours.

Advanced out-of-the-box PTAB and TTAB analytics are always at your fingertips.

API

Docket Alarm offers a powerful API (application programming interface) to developers that want to integrate case filings into their apps.

LAW FIRMS

Build custom dashboards for your attorneys and clients with live data direct from the court.

Automate many repetitive legal tasks like conflict checks, document management, and marketing.

FINANCIAL INSTITUTIONS

Litigation and bankruptcy checks for companies and debtors.

E-DISCOVERY AND LEGAL VENDORS

Sync your system to PACER to automate legal marketing.