

UNITED STATES PATENT AND TRADEMARK OFFICE

BEFORE THE PATENT TRIAL AND APPEAL BOARD

SHENZHEN APALTEK CO., LTD. And
COOLER MASTER CO., LTD.,
Petitioner,

v.

ASETEK DANMARK A/S,
Patent Owner.

IPR2022-01317*
Patent 8,245,764 B2

Before WILLIAM V. SAINDON, KEVIN W. CHERRY, and
JASON W. MELVIN, *Administrative Patent Judges*.

MELVIN, *Administrative Patent Judge*.

JUDGMENT
Final Written Decision
Determining All Challenged Claims Unpatentable
35 U.S.C. § 318(a)

* Cooler Master Co., Ltd., which filed a petition in IPR2023-00668, has been joined as a party to this proceeding.

I. INTRODUCTION

ShenZhen Apaltek Co., Ltd. (“Petitioner”) filed a Petition (Paper 1, “Pet.”) requesting institution of *inter partes* review of claims 1–30 of U.S. Patent No. 8,245,764 B2 (Ex. 1001, “the ’764 patent”). Asetek Danmark A/S (“Patent Owner”) filed a Preliminary Response. Paper 5. As authorized, Petitioner filed a Preliminary Reply. Paper 6. Pursuant to 35 U.S.C. § 314 and 37 C.F.R. § 42.4(a), we instituted review. Paper 7. We joined Cooler Master Co., Ltd., as a Petitioner here pursuant to a motion filed in IPR2023-00668. Paper 9. No party filed a paper after institution.

We have jurisdiction under 35 U.S.C. § 6. This is a Final Written Decision under 35 U.S.C. § 318(a) as to the patentability of claims 1–30 of the ’764 patent. We hold that Petitioner has demonstrated by a preponderance of the evidence that the challenged claims are unpatentable.

A. REAL PARTIES IN INTEREST

Petitioner ShenZhen Apaltek identifies itself as the real party in interest. Pet. 146. Petitioner Cooler Master identifies itself as the real party in interest. IPR2023-00668, Paper 3, 146. Patent Owner identifies Asetek Danmark A/S, Asetek USA, Inc., Asetek A/S, and Asetek Holdings, Inc. as the real parties in interest for Patent Owner. Paper 4, 1 (Patent Owner’s Mandatory Notices).

B. RELATED MATTERS

The parties identify the following related litigations: *Asetek Danmark A/S v. CoolIT Systems, Inc.*, No. 3:19-cv-00410 (N.D. Cal.); *Cooler Master Co., Ltd. v. Asetek Danmark A/S*, No. 4:21-cv-04627 (N.D. Cal.); and *Asetek*

IPR2022-01317
Patent 8,245,764 B2

Danmark A/S v. Shenzhen Apaltek Co., Ltd., No. 6:21-cv-00501 (W.D. Tex.)
(transferred to N.D. Cal., May 6, 2022). Pet. 147; Paper 4, 1.

The parties also identify the following Office proceedings:
IPR2020-00522, IPR2020-00523, and IPR2020-00524, which were filed in
February 2020 and concluded in August 2021, IPR2021-01195 against U.S.
Patent No. 10,613,601 and IPR2021-01196 against U.S. Patent
No. 10,599,196. Pet. 147; Paper 4, 1–2.

C. THE '764 PATENT

The '764 patent is titled “Cooling System for a Computer System.”
Ex. 1001, code (54). It issued from an application filed October 7, 2011, as a
continuation of and claims priority to a PCT application filed May 6, 2005.
Id. at code (63).

The '764 patent relates to a liquid-cooling system for a computer
system. *Id.* at Code (57). The specification explains, at the time of the
invention, air cooling arrangements were the most-used cooling system for
cooling central processing units (CPUs) in computer systems. *Id.* at 1:17–31.
An alternative design known at the time of the invention was to use a
cooling liquid circulating inside a closed system by means of a pumping unit
with a heat exchanger past which the cooling liquid circulates. *Id.* at 1:32–
36. The specification contends that liquid cooling is generally more efficient
and quieter than air cooling, but that a liquid cooling design consists of
“many components,” which increases the total installation time, size, and
risk of leakage of the cooling liquid from the system. *Id.* at 1:37–47. Thus,
one object of the invention is to provide a small and compact liquid-cooling
solution that is more efficient than existing air-cooling arrangements and can
be produced at low cost enabling high production volumes, be easy-to-use

and implement, can be used with existing CPU types and computer systems, and requires a low level of maintenance or no maintenance at all. *Id.* at 1:51–60.

An illustrative embodiment of such a device is depicted in Figures 7 and 8, reproduced below.

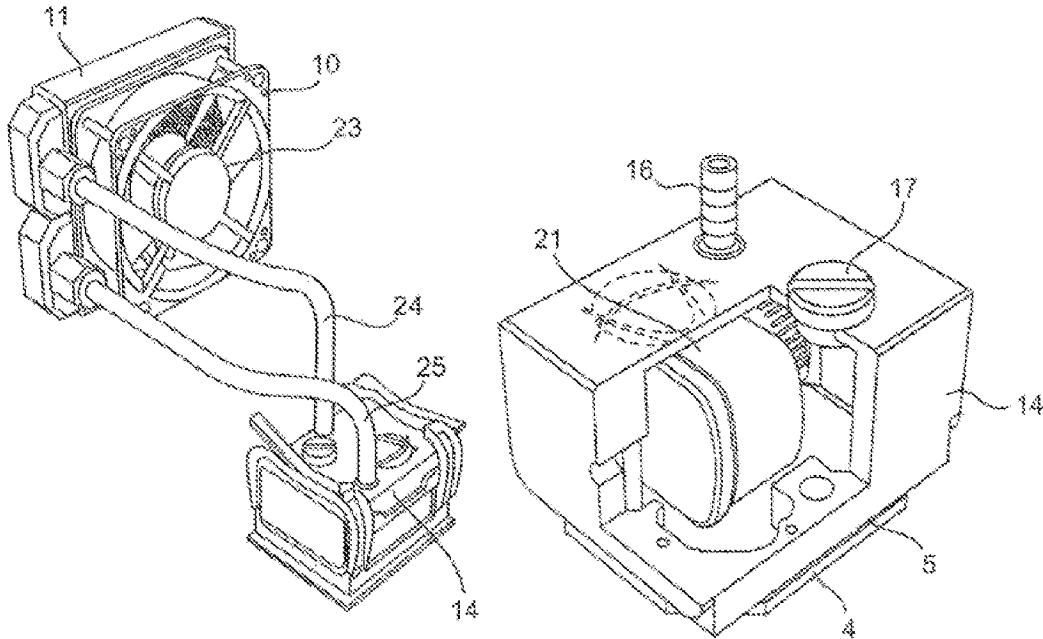

FIG. 7

FIG. 8

Figure 7¹ is a perspective view of the cooling system showing reservoir housing 14 with the heat exchanging surface 5 (shown in Figure 8) and the pump 21 (shown in Figure 8) inside the reservoir. *Id.* at 15:61–16:7. Figure 8 is a cut-out view into reservoir housing 14, when the reservoir, pump 21, and

¹ It appears the specification transposes the description of Figure 7 with that of Figure 8. We refer to the description of “Figure 8” in the specification in our discussion of Figure 7, and we refer to the specification’s discussion of “Figure 7” in our discussion of Figure 8.

heat exchanging surface 4 are situated inside the reservoir. *Id.* at 15:28–30. The reservoir has a tube inlet connection (not shown in Figure 8) through which the cooling liquid enters the reservoir. *Id.* at 15:30–32. From the tube inlet connection, the cooling liquid flows through the reservoir passing heat exchanging surface 4 and enters the inlet of the pump. *Id.* at 15:32–35. After the cooling liquid flows through the pump, the cooling liquid passes out of the outlet of the pump and further out through tube outlet connection 16. *Id.* at 15:35–37. As shown in Figure 7, tube inlet connection and tube outlet connection 16 are connected to heat radiator 11 by means of connecting tubes 24 and 25. *Id.* at 15:64–67. Cooling liquid flows into and out of the reservoir and the heat radiator through connecting tubes 24 and 25, respectively. *Id.* Heat radiator 11 (shown in Figure 7) cools the cooling liquid before it passes back into the reservoir. *Id.* at 15:67–16:4.

The reservoir may be provided with channels or segments for establishing a certain flow-path for the cooling liquid through the reservoir to prevent the cooling liquid passing the reservoir too quickly to take up a sufficient amount of heat from the heat exchanging surface. *Id.* at 16:25–42.

Figures 17 and 20 show the internal structures of a preferred embodiment of the reservoir according to the invention and are reproduced below. *Id.* at 21:12–22:59.

Explore Litigation Insights

Docket Alarm provides insights to develop a more informed litigation strategy and the peace of mind of knowing you're on top of things.

Real-Time Litigation Alerts



Keep your litigation team up-to-date with **real-time alerts** and advanced team management tools built for the enterprise, all while greatly reducing PACER spend.

Our comprehensive service means we can handle Federal, State, and Administrative courts across the country.

Advanced Docket Research



With over 230 million records, Docket Alarm's cloud-native docket research platform finds what other services can't. Coverage includes Federal, State, plus PTAB, TTAB, ITC and NLRB decisions, all in one place.

Identify arguments that have been successful in the past with full text, pinpoint searching. Link to case law cited within any court document via Fastcase.

Analytics At Your Fingertips



Learn what happened the last time a particular judge, opposing counsel or company faced cases similar to yours.

Advanced out-of-the-box PTAB and TTAB analytics are always at your fingertips.

API

Docket Alarm offers a powerful API (application programming interface) to developers that want to integrate case filings into their apps.

LAW FIRMS

Build custom dashboards for your attorneys and clients with live data direct from the court.

Automate many repetitive legal tasks like conflict checks, document management, and marketing.

FINANCIAL INSTITUTIONS

Litigation and bankruptcy checks for companies and debtors.

E-DISCOVERY AND LEGAL VENDORS

Sync your system to PACER to automate legal marketing.