

UNITED STATES PATENT AND TRADEMARK OFFICE

BEFORE THE PATENT TRIAL AND APPEAL BOARD

TRW AUTOMOTIVE US LLC
Petitioner

v.

MAGNA ELECTRONICS INC.
Patent Owner

Case IPR2014-00263
Patent 8,222,588 B2

Before JUSTIN T. ARBES, BARRY L. GROSSMAN, and
BEVERLY M. BUNTING, *Administrative Patent Judges*.

GROSSMAN, *Administrative Patent Judge*.

DECISION
Denying Institution of *Inter Partes* Review
37 C.F.R. § 42.108

I. INTRODUCTION

TRW Automotive US LLC (“Petitioner”) filed a Petition requesting an *inter partes* review of claims 1-6, 8–23, and 25–27 of U.S. Patent No. 8,222,588 B2 (“the ’588 patent”). Paper 1 (“Pet.”). The patent owner, Magna Electronics Inc. (“Patent Owner”), filed a Preliminary Response. Paper 7 (“Prelim. Resp.”).

The standard for instituting an *inter partes* review is set forth in 35 U.S.C. § 314(a):

THRESHOLD.—The Director may not authorize an *inter partes* review to be instituted unless the Director determines that the information presented in the petition filed under section 311 and any response filed under section 313 shows that there is a reasonable likelihood that the petitioner would prevail with respect to at least 1 of the claims challenged in the petition.

We determine that the information presented does not show that there is a reasonable likelihood that Petitioner would prevail in establishing the unpatentability of any of claims 1-6, 8–23, and 25–27. Accordingly, we deny the Petition and do not institute an *inter partes* review of the ’588 patent.

A. Related Proceedings

TRW states that the ’588 patent is involved in a pending district court case, titled *Magna Electronics Inc. v. TRW Automotive Holdings Corp.*, No. 1:12-cv-00654-PLM (W.D. Mich.). Pet. 5.

B. The ’588 Patent

The challenged claims are directed to an image sensing system. Ex. 1002, col. 12, l. 58. The patent relates, in particular, to a system for controlling the headlights of a vehicle. *Id.*, col. 1, ll. 23–25. The disclosed system particularly is adapted to controlling the vehicle’s headlamps in response to sensing the headlights of oncoming vehicles and taillights of leading vehicles. *Id.*, col. 1, 25–28. The image processing system is capable of identifying unique characteristics

of light sources by comparing light source characteristics with spectral signatures of known light sources, such as headlights and taillights. *Id.*, col. 1, l. 67–col. 2, l. 9.

As shown generally in Figure 2 of the '588 patent, reproduced below, the image processing system includes imaging sensor module 14, which senses light from a scene forward of the vehicle; imaging control circuit 13¹, which receives data from sensor 14; and vehicle lighting control logic module 16, which exchanges data with control circuit 13 and controls headlamps 18 for the purpose of modifying the headlight beam. Ex. 1002, col. 3, ll. 44–51.

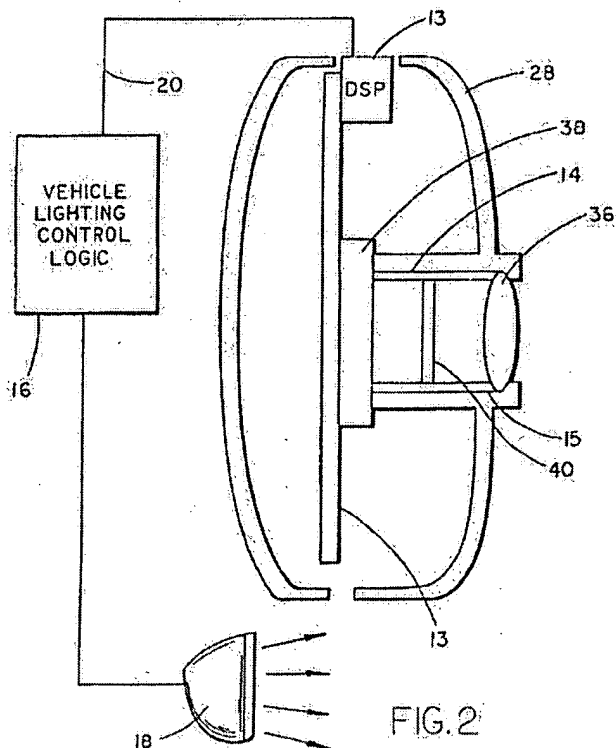

Fig. 2 of the '588 patent.

¹ The Specification also refers to imaging control circuit 13 as a “digital signal processor.” See Ex. 1002, col. 3, l. 47 (“imaging control circuit 13”); col. 4, ll. 53–54 (“digital signal processor 13”). This explains why reference numeral 13 in Figure 2 points to a box labelled “DSP.”

Imaging sensor module 14 includes a lens, an array of photon-accumulating light sensors, and a spectral separation device, such as a filter array, for separating light from the scene forward of the vehicle into a plurality of spectral bands. Ex. 1002, col. 4, ll. 24–29. Digital signal processor 13 includes an analog-to-digital converter, which receives the output of the array of photon-accumulating light sensors and converts the analog pixel values to digital values. *Id.* at col. 4, ll. 56–58. The digital values are supplied to a taillight detection circuit and a headlight detection circuit. *Id.* at col. 4, ll. 58–60.

The taillight detection circuit detects a red light source having an intensity above a particular threshold. Ex. 1002, col. 5, ll. 4–5. For each pixel that is “red,” a comparison is made with adjacent “green” pixels and “blue” pixels. *Id.* at col. 5, ll. 6–7. If the intensity of a red pixel is more than a particular number of times the intensity of an adjacent green pixel and an adjacent blue pixel, then it is determined that the light source is red. *Id.* at col. 5, ll. 7–10. The headlight detection circuit carries out a similar process. *Id.* at col. 5, ll. 13–21. The image processing system recognizes the spectral signatures of detected light sources, i.e., headlights and taillights, as well as the spectral signatures of rejected light sources, such as lane markers, signs, and other sources of reflected light, all of which may be readily identified by their spectral signature. *Id.*, col. 10, ll. 38–47.

C. Illustrative Claim

Challenged claim 1, the sole challenged independent claim, reproduced below, is illustrative of the claimed invention:

1. An image sensing system for a vehicle, said image sensing system comprising:
 - an imaging sensor comprising a two-dimensional array of light sensing pixels;

said imaging sensor having a forward field of view through the windshield of a vehicle equipped with said image sensing system to the exterior of the equipped vehicle;

wherein said imaging sensor is operable to capture image data;

a control comprising an image processor;

wherein said image sensing system determines an object of interest present in said forward field of view of said imaging sensor via processing of said captured image data by said image processor; and

wherein said image processing comprises spatial filtering.

D. References Relied Upon

Petitioner relies upon the following prior art references:

Reference	Date	Exhibit Number
Kenue, U.S. Pat. No. 4,970,653.	Issued Nov. 13, 1990	Ex. 1004
Yanagawa, Japanese Kokai Application, No. S62- 131837, with certified translation.	Published June 15, 1987	Ex. 1005
Bottesch, U.S. Pat. No. 5,166,681.	Issued Nov. 24, 1992	Ex. 1006
Tadashi, Japanese Kokai Application No. Hei 4- 127280, with certified translation. ²	Published April 28, 1992	Ex. 1007

² We refer to “Yanagawa” and “Tadashi” as the English translations of the original references. Petitioner provided affidavits attesting to the accuracy of the translations. *See* Exs. 1005, 1007; 37 C.F.R. § 42.63(b).

Explore Litigation Insights

Docket Alarm provides insights to develop a more informed litigation strategy and the peace of mind of knowing you're on top of things.

Real-Time Litigation Alerts



Keep your litigation team up-to-date with **real-time alerts** and advanced team management tools built for the enterprise, all while greatly reducing PACER spend.

Our comprehensive service means we can handle Federal, State, and Administrative courts across the country.

Advanced Docket Research



With over 230 million records, Docket Alarm's cloud-native docket research platform finds what other services can't. Coverage includes Federal, State, plus PTAB, TTAB, ITC and NLRB decisions, all in one place.

Identify arguments that have been successful in the past with full text, pinpoint searching. Link to case law cited within any court document via Fastcase.

Analytics At Your Fingertips



Learn what happened the last time a particular judge, opposing counsel or company faced cases similar to yours.

Advanced out-of-the-box PTAB and TTAB analytics are always at your fingertips.

API

Docket Alarm offers a powerful API (application programming interface) to developers that want to integrate case filings into their apps.

LAW FIRMS

Build custom dashboards for your attorneys and clients with live data direct from the court.

Automate many repetitive legal tasks like conflict checks, document management, and marketing.

FINANCIAL INSTITUTIONS

Litigation and bankruptcy checks for companies and debtors.

E-DISCOVERY AND LEGAL VENDORS

Sync your system to PACER to automate legal marketing.