

UNITED STATES PATENT AND TRADEMARK OFFICE

BEFORE THE PATENT TRIAL AND APPEAL BOARD

WALMART INC.,
Petitioner,

v.

CARAVAN CANOPY INTERNATIONAL, INC.,
Patent Owner.

IPR2020-01026
Patent 5,944,040

Before BART A. GERSTENBLITH, JAMES J. MAYBERRY, and
ERIC C. JESCHKE, *Administrative Patent Judges*.

JESCHKE, *Administrative Patent Judge*.

DECISION
Granting Institution of *Inter Partes* Review
35 U.S.C. § 314

I. BACKGROUND

Petitioner, Walmart Inc., filed a Petition to institute an *inter partes* review of claims 1–3 (the “challenged claims”) of U.S. Patent No. 5,944,040 (Ex. 1001, “the ’040 patent”). Paper 1 (“Pet.”). Patent Owner, Caravan Canopy International, Inc. filed a Preliminary Response. Paper 8 (“Prelim. Resp.”). With Board authorization (Paper 9), Petitioner timely filed a Preliminary Reply to Patent Owner’s Preliminary Response (Paper 10, “Prelim. Reply”), and Patent Owner timely filed a Preliminary Sur-reply to Petitioner’s Preliminary Reply (Paper 11, “Prelim. Sur-reply”).

We have authority to determine whether to institute an *inter partes* review. *See* 35 U.S.C. § 314 (2018); 37 C.F.R. § 42.4(a) (2019) (“The Board institutes the trial on behalf of the Director.”). Section 314(a) of Title 35 of the United States Code provides that an *inter partes* review may not be instituted “unless . . . the information presented in the petition . . . shows that there is a reasonable likelihood that the petitioner would prevail with respect to at least 1 of the claims challenged in the petition.” Upon consideration of the arguments in the briefing and the evidence of record (including testimonial evidence), for the reasons below, we determine that the Petition shows a reasonable likelihood that Petitioner would prevail with respect to at least one of the challenged claims. We thus institute *inter partes* review on all challenged claims on all asserted grounds. *See SAS Inst., Inc. v. Iancu*, 138 S. Ct. 1348, 1354, 1359–60 (2018); Consolidated Trial Practice Guide 64 (Nov. 2019), <https://www.uspto.gov/TrialPracticeGuideConsolidated> (“Consolidated TPG”) (“The Board will not institute on fewer than all claims or all challenges in a petition.”).

A. Related Proceedings

The parties identify a proceeding in the U.S. District Court for the Central District of California (“the District Court”) in which Patent Owner asserts the ’040 patent against Petitioner: *Caravan Canopy Int’l, Inc. v. Walmart Inc.*, 2:19-cv-06978 (C.D. Cal.), filed Aug. 12, 2019 (the “Walmart Litigation”). Pet. 84; Paper 5 (Patent Owner’s Mandatory Notices), at 1. The Walmart Litigation was stayed on August 19, 2020. See Paper 6 (Petitioner’s Updated Mandatory Notices), at 2 (discussing Ex. 1019 (order staying the Walmart Litigation)).

The parties also identify other proceedings in which Patent Owner has asserted or is asserting the ’040 patent against parties not involved in this *inter partes* review:

1. *Caravan Canopy Int’l, Inc. v. The Home Depot USA, Inc.*, 8:19-cv-01072 (C.D. Cal.), filed May 31, 2019;
2. *Caravan Canopy Int’l, Inc. v. ShelterLogic Corp.*, 5:19-cv-01224 (C.D. Cal.), filed July 1, 2019;
3. *Caravan Canopy Int’l, Inc. v. Z-Shade Co. Ltd.*, 2:19-cv-06224 (C.D. Cal.), filed July 18, 2019;
4. *Caravan Canopy Int’l, Inc. v. Lowe’s Home Centers, LLC*, 2:19-cv-06952 (C.D. Cal.), filed August 9, 2019;
5. *Caravan Canopy Int’l, Inc. v. Bravo Sports*, 2:19-cv-06031 (C.D. Cal.), filed July 12, 2019 (dismissed without prejudice);
6. *Int’l E-Z Up v. Caravan Canopy Int’l, Inc.*, 2:01-cv-06530 (C.D. Cal.), filed July 30, 2001 (settled);
7. *Jang v. Caravan Canopy Int’l, Inc.*, 2:03-cv-01024 (C.D. Cal.), filed February 11, 2003 (settled).

Pet. 84–85; Paper 5, at 1. On December 13, 2019, the District Court consolidated proceedings 1–4 listed above (collectively, “the Ongoing Litigations”) and the Walmart Litigation “for all purposes except for trial.” Ex. 2001, at 1. After the District Court granted the stay of the Walmart Litigation, several of the defendants in the Ongoing Litigations requested clarification that the stay applies to all the consolidated cases. *See* Ex. 2004 (Request for Clarification re Stay of Litigation). On August 28, 2020, the District Court denied the “request for clarification.” Ex. 2005 (order denying Request for Clarification). The Ongoing Litigations are thus currently active.

B. The '040 Patent

The '040 patent relates to collapsible tent frames. *See* Ex. 1001, 1:1–10. According to the '040 patent, when pitching (i.e., putting up) existing collapsible tent frames, “the center pole ribs 3 are positioned across the upper portion of the interior space as shown in FIG. 2 [below], thus limiting the height of the interior space.”¹ *Id.* at 1:57–60. Inconvenience results because users must be mindful not to bump their heads against center pole ribs 3 or connector 4 when entering or standing in the tent. *See id.* at 1:61–64.

¹ Throughout this Decision, we omit any bold emphasis of reference numerals and figure numbers in quotations from the '040 patent and from the relied-upon references.

Figures 1 and 2 are reproduced below:

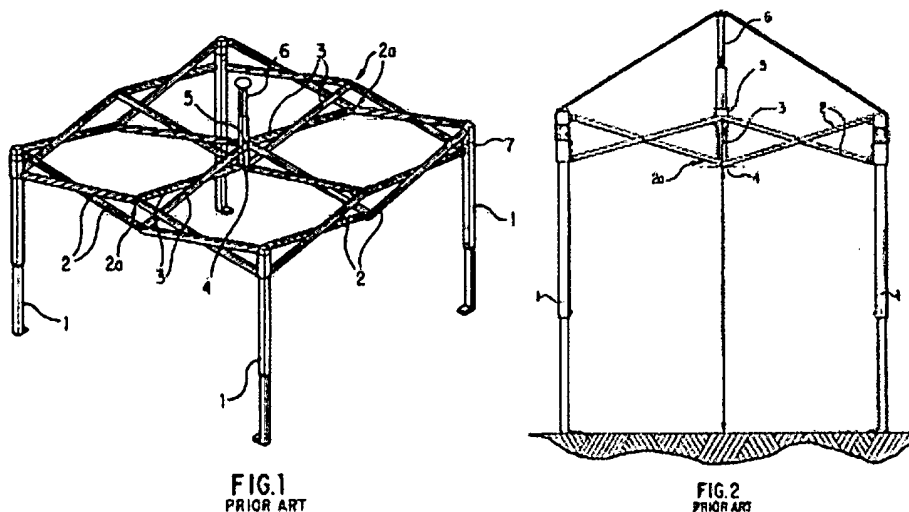
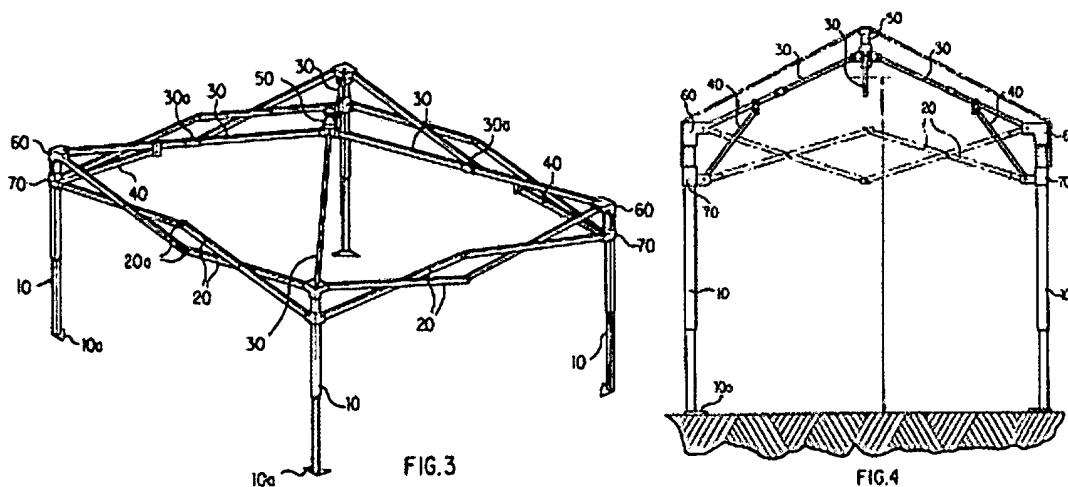

Figure 1 is a “perspective view showing the construction of a typical collapsible tent frame” and Figure 2 is a “sectional view of a tent with the typical collapsible tent frame when the tent is completely pitched.”

Ex. 1001, 2:35–38. The '040 patent discloses that, because center pole 6 includes connector 4 and slide guider 5, the existing collapsible tent frames have “a complex construction” and increased production costs. *See id.* at 1:65–67. The existing tent frames are also described as “too heavy for a user to easily handle or move.” *Id.* at 2:1–2.

Figures 3 and 4 are reproduced below:



Explore Litigation Insights

Docket Alarm provides insights to develop a more informed litigation strategy and the peace of mind of knowing you're on top of things.

Real-Time Litigation Alerts



Keep your litigation team up-to-date with **real-time alerts** and advanced team management tools built for the enterprise, all while greatly reducing PACER spend.

Our comprehensive service means we can handle Federal, State, and Administrative courts across the country.

Advanced Docket Research



With over 230 million records, Docket Alarm's cloud-native docket research platform finds what other services can't. Coverage includes Federal, State, plus PTAB, TTAB, ITC and NLRB decisions, all in one place.

Identify arguments that have been successful in the past with full text, pinpoint searching. Link to case law cited within any court document via Fastcase.

Analytics At Your Fingertips



Learn what happened the last time a particular judge, opposing counsel or company faced cases similar to yours.

Advanced out-of-the-box PTAB and TTAB analytics are always at your fingertips.

API

Docket Alarm offers a powerful API (application programming interface) to developers that want to integrate case filings into their apps.

LAW FIRMS

Build custom dashboards for your attorneys and clients with live data direct from the court.

Automate many repetitive legal tasks like conflict checks, document management, and marketing.

FINANCIAL INSTITUTIONS

Litigation and bankruptcy checks for companies and debtors.

E-DISCOVERY AND LEGAL VENDORS

Sync your system to PACER to automate legal marketing.