

UNITED STATES PATENT AND TRADEMARK OFFICE

BEFORE THE PATENT TRIAL AND APPEAL BOARD

RIOT GAMES, INC.,
Petitioner,

v.

PALTALK HOLDINGS, INC.,
Patent Owner.

Case IPR2018-00132
Patent 6,226,686 & 6,226,686 C1¹

Before THU A. DANG and KARL EASTHOM,
Administrative Patent Judges.

DANG, *Administrative Patent Judge.*

DECISION
Institution of *Inter Partes* Review
35 U.S.C. 314(a)

¹ The Petition challenges original claims and claims issued pursuant to an ex parte reexamination.

I. INTRODUCTION

A. Background

Riot Games Inc. (“Petitioner”) filed a Petition requesting an *inter partes* review of claims 1, 3, 7, 12, 18, 22–27, 36, 41–46, 55, and 58–63 of U.S. Patent No. 6,226,686 (Ex. 1002, “the ’686 patent”). Paper 1 (“Pet.”). PalTalk Holdings, Inc. (“Patent Owner”) filed a Preliminary Response. Paper 6 (“Prelim. Resp.”).

We have jurisdiction under 35 U.S.C. § 314, which provides that an *inter partes* review may not be instituted “unless . . . there is a reasonable likelihood that the petitioner would prevail with respect to at least 1 of the claims challenged in the petition.” 35 U.S.C. § 314(a); *see also* 37 C.F.R. 42.4(a) (“The Board institutes the trial on behalf of the Director.”). Upon considering the record before us, we determine that Petitioner has shown a reasonable likelihood that it would prevail in showing the unpatentability of at least one of the challenged claims. Accordingly, we *grant* the Petition.

B. Related Proceedings

Petitioner states that the ’686 patent is related to the following U.S. Patents: 5,822,523 (“the ’523 patent”) and 6,018,766. Pet. 1. According to Petitioner, *ex partes* reexamination No. 90/011,036 (Ex. 1006) involved a reexamination of the ’686 patent. Pet. 1.

A concurrent request for *inter partes* review, IPR2018-00131, challenges claims of the ’686 patent. Pet. 1. Two other concurrent requests for *inter partes* review, IPR2018-00129, and IPR2018-00130, challenge claims of the ’523 patent. Pet. 1.

Petitioner also states that the following cases involve the ’523 and ’686 patents: *PalTalk Holdings, Inc. v. Valve Corporation*, No. 16-cv-

IPR2018-00132
Patent 6,226,686

1239-JFB-SRF (D. Del.) (filed Dec. 16, 2016); *PalTalk Holdings, Inc. v. Riot Games, Inc.*, Case No. 1:16-cv-1240-JFB-SRF (D. Del.) (filed Dec. 16, 2016); *PalTalk Holdings, Inc. v. Sony Computer Entertainment America, Inc. et al.*, Case No. 2:09-cv-00274-DF-CE (E.D. Tex.) (filed Sept. 14, 2009); *PalTalk Holdings, Inc. v. Microsoft Corporation*, Case No. 2:06-cv-00367-DF (E.D. Tex.) (filed Sept. 12, 2006); and *Mpath Interactive v. Lipstream Networks, Inc., et al.*, Case No. 3:99-cv-04506-WHA (N.D. Cal.) (filed Oct. 7, 1999). Pet. 1–2.

C. *The '686 Patent*

The '686 patent issued on May 1, 2001, from an application filed September 28, 1999, and claims priority to parent application No. 08/896,797, filed on July 18, 1997, now US 6,018,766, which in turn is a continuation of application No. 08/595,323, filed on February 1, 1996, now US 5,822,523. Ex. 1002, at [45], [22], [63].

The '686 patent is directed to “server-group messaging,” and describes a “method for deploying interactive applications over a network containing host computers and group messaging servers.” *Id.* at [57]. Figure 5, reproduced below, illustrates a unicast network over which the interactive applications may be deployed.

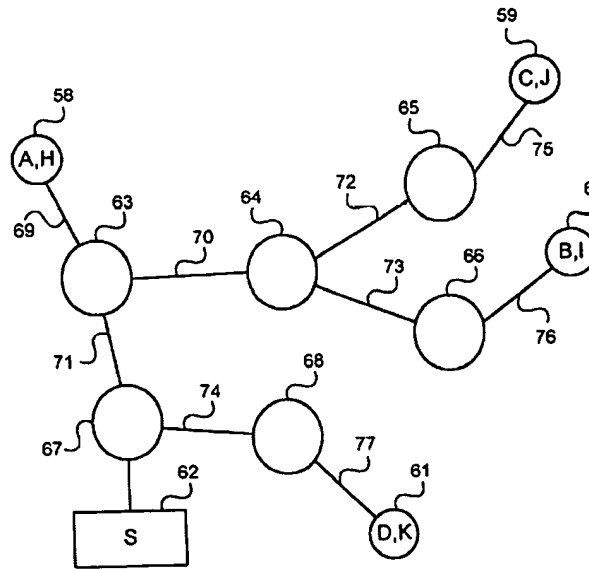

Figure 5

Figure 5 depicts a wide area network with hosts 58, 59, 60, and 61, and a group messaging server (“GMS”) 62. *Id.* at 8:65–66. Host 58 has Transport Level Protocol (TLP) address A and Upper Level Protocol (ULP) address H. *Id.* at 8:66–67. Host 59 has TLP address C and ULP address J, host 60 as TLP address B and ULP address I, host 61 has TLP address D and ULP address K, and GMS 62 has TLP address S. *Id.* at 8:67–9:2. “The network is a conventional unicast network of network links 69, 70, 71, 72, 73, 74, 75, 76, and 77 and unicast routers 63, 64, 65, 66, 67, and 68.” *Id.* at 9:2–5. GMS 62 “receives messages from the hosts addressed to a message group and sends the contents of the messages to the members of the message group.” *Id.* at 9:5–8.

Figure 7, reproduced below, depicts ULP datagrams with payload aggregations for implementing an interactive gaming application between the four hosts in Figure 5.

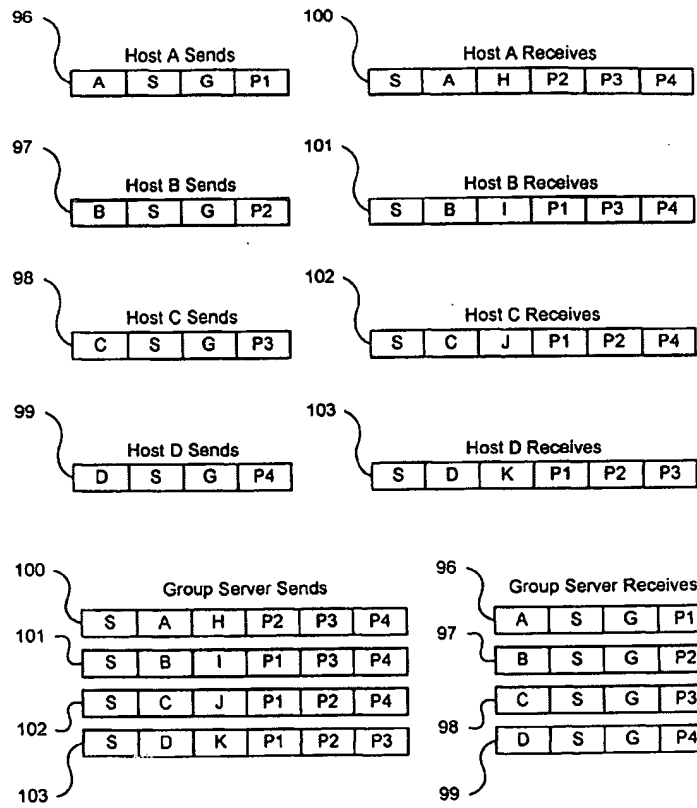

Figure 7

Figure 7 shows GMS (“Group Server”) 62 receiving multiple messages 96, 97, 98, and 99 before sending them to hosts within message group G. *Id.* at 9, 18–20, 10:24–28. As shown in Figure 7, multiple messages 96, 97, 98, and 99, each respectively contain payload P1, P2, P3, and P4, to be aggregated into a single larger message, 100, 101, 102, or 103. *Id.* Host 58 sends message 96 (shown in Figure 7 as “Host A sends”), host 60 sends message 97 (shown in Figure 7 as “Host B sends”), host 59 sends message 98 (shown in Figure 7 as “Host C sends”), and host 61 sends message 99 (shown in Figure 7 as “Host D sends”), wherein each of the messages from the hosts has destination TLP address S and ULP address G for GMS 62. *Id.* at 10:28–32. After GMS 62 receives all four of these messages, it creates four outbound messages 100, 101, 102, and 103. *Id.* at 10:33–34.

Explore Litigation Insights

Docket Alarm provides insights to develop a more informed litigation strategy and the peace of mind of knowing you're on top of things.

Real-Time Litigation Alerts



Keep your litigation team up-to-date with **real-time alerts** and advanced team management tools built for the enterprise, all while greatly reducing PACER spend.

Our comprehensive service means we can handle Federal, State, and Administrative courts across the country.

Advanced Docket Research



With over 230 million records, Docket Alarm's cloud-native docket research platform finds what other services can't. Coverage includes Federal, State, plus PTAB, TTAB, ITC and NLRB decisions, all in one place.

Identify arguments that have been successful in the past with full text, pinpoint searching. Link to case law cited within any court document via Fastcase.

Analytics At Your Fingertips



Learn what happened the last time a particular judge, opposing counsel or company faced cases similar to yours.

Advanced out-of-the-box PTAB and TTAB analytics are always at your fingertips.

API

Docket Alarm offers a powerful API (application programming interface) to developers that want to integrate case filings into their apps.

LAW FIRMS

Build custom dashboards for your attorneys and clients with live data direct from the court.

Automate many repetitive legal tasks like conflict checks, document management, and marketing.

FINANCIAL INSTITUTIONS

Litigation and bankruptcy checks for companies and debtors.

E-DISCOVERY AND LEGAL VENDORS

Sync your system to PACER to automate legal marketing.