

EXHIBIT 14



(21) Application No. 200920151031.1

(22) Application Date 28 April 2009

(73) Patentee Minilogic Device Co., Ltd.
Address Room 508-509, IC Development Centre,
Science Park, Sha Tin, Hong Kong, China

(72) Inventor Liao Laiying

(74) Patent Agency Guangdong Guoxin Law Firm
44221

Agent Li Wen

(51) Int. Cl.

B05B 17/00 (2006.01)

B05B 15/00 (2006.01)

A24B 15/00 (2006.01)

Claims 1 Page Specification 3 Pages Drawings 2 Pages

(54) Utility Model Title

Electronic atomizer

(57) Abstract

An electronic atomizer relates to a battery-powered heating apparatus. The electronic atomizer includes a housing and a battery disposed inside the housing. A processing chip, a heating apparatus, and a sensing apparatus are disposed inside the housing. The processing chip is electrically connected to the battery, the heating apparatus, and the sensing apparatus. An airflow sensing switch circuit, a heating drive circuit, a charging mode detection circuit, a battery charging and protection circuit, and a light-emitting diode drive circuit are disposed in the processing chip. An output pin of the heating drive circuit is connected to the heating apparatus, an output pin of the light-emitting diode drive circuit is connected to a light-emitting diode, an input pin of the airflow sensing switch circuit is connected to the sensing apparatus, one end of the charging mode detection circuit and one end of the battery charging and protection circuit are connected to the battery, and the other end is connected to a power input end. In the present utility model, smoking actions of a user are sensed by airflow sensing, so the life span of a switch apparatus can be greatly improved, sensitivity can be increased, accidental triggering is eliminated, and assembly costs are reduced.

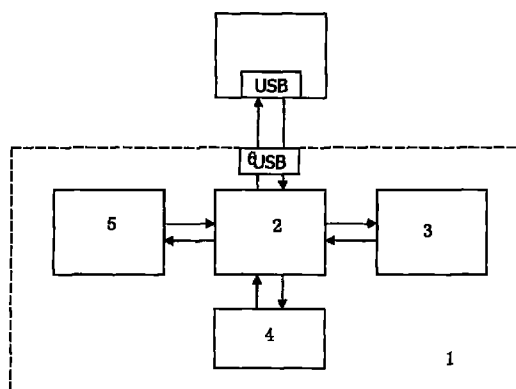

CN 201482667 U

1. An electronic atomizer, comprising a housing (1) and a battery (5) disposed inside the housing, wherein a processing chip (2), a heating apparatus (3), and a sensing apparatus (4) are disposed inside the housing (1), the processing chip (1) is electrically connected to the battery (5), the heating apparatus (3), and the sensing apparatus (4), an airflow sensing switch circuit (21), a heating drive circuit (22), a charging mode detection circuit (23), a battery charging and protection circuit (24), and a light-emitting diode drive circuit (25) are disposed in the processing chip (2), an output pin of the heating drive circuit (22) is connected to the heating apparatus (3), an output pin of the light-emitting diode drive circuit (25) is connected to a light-emitting diode D1, an input pin of the airflow sensing switch circuit (21) is connected to the sensing apparatus (4), one end of the charging mode detection circuit (23) and one end of the battery charging and protection circuit (24) are connected to the battery (5), and the other end is connected to a power input end.

2. The electronic atomizer according to claim 1, wherein an electronic serial interface (6) is disposed inside the housing (1), an opening to be used by the electronic serial interface is disposed on the housing (1), and the electronic serial interface (6) is electrically connected to the processing chip (2).

3. The electronic atomizer according to claim 1, wherein a battery compartment is disposed inside the housing (1), and the battery is installed inside the battery compartment.

4. The electronic atomizer according to claim 1, wherein the heating apparatus (3) is a heating wire.

5. The electronic atomizer according to claim 1, wherein the sensing apparatus (4) is a capacitive airflow sensor.

6. The electronic atomizer according to claim 2, wherein the electronic serial interface (6) is a USB interface.

7. The electronic atomizer according to claim 1, wherein a pin 1 of the processing chip (2) is set to an input pin of the airflow sensing switch circuit, a pin 2 is set to a grounding pin, a pin 3 is set to an output pin of the light-emitting diode drive circuit, a pin 4 is set to an output pin of the heating drive circuit, an input pin of the charging mode detection circuit, and an input pin of the battery charging and protection circuit, and a pin 5 is set to a power input pin.

8. The electronic atomizer according to claim 1, wherein the heating drive circuit (22) outputs a voltage to the heating apparatus (3) through pulse width modulation.

Technical Field

[0001] The present utility model relates to a battery-powered heating apparatus.

Background of the Invention

[0002] All electronic atomizers on the market are powered by lithium batteries or other power supplies, and liquid is atomized by using heating wires and is then inhaled by a user. In medical application, medicinal liquid is atomized. In the application of electronic cigarettes, a simulated traditional tobacco effect or liquid of another flavor is atomized. All current electronic cigarettes sense a smoking action of the user by using various switch apparatuses, such as a mechanical switch or a Hall-effect switch, to determine to turn on or turn off a heating apparatus. All these switch apparatuses have a mechanical part or a magnetic induction part, and as a result, a product has a short life span and is prone to accidental triggering or lacks sensitivity.

Summary of the Invention

[0003] An objective of the present utility model is to provide an electronic atomizer on which a switch is controlled through airflow sensing.

[0004] The objective of the present utility model may be implemented in this way: An electronic atomizer includes a housing and a battery disposed inside the housing. A processing chip, a heating apparatus, and a sensing apparatus are disposed inside the housing. The processing chip is electrically connected to the battery, the heating apparatus, and the sensing apparatus. An airflow sensing switch circuit, a heating drive circuit, a charging mode detection circuit, a battery charging and protection circuit, and a light-emitting diode drive circuit are disposed in the processing chip. An output pin of the heating drive circuit is connected to the heating apparatus, an output pin of the light-emitting diode drive circuit is connected to a light-emitting diode, an input pin of the airflow sensing switch circuit is connected to the sensing apparatus, one end of the charging mode detection circuit and one end of the battery charging and protection circuit are connected to the battery, and the other end is connected to a power input end.

[0005] In the present utility model, smoking actions of a user are sensed by innovative airflow sensing, so the life span of a switch apparatus can be greatly improved, sensitivity can be increased, accidental triggering is eliminated, and assembly costs are reduced.

Description of Drawings

[0006] Fig. 1 is a schematic structural diagram of an embodiment of the present utility model.

[0007] Fig. 2 is a function module diagram of an embodiment of the present utility model.

[0008] Fig. 3 is a circuit principle diagram of a heating mode of an embodiment of the present utility model.

[0009] Fig. 4 is a circuit principle diagram of a charging mode of an embodiment of the present utility model.

Specific Embodiments

[0010] The following further describes the present utility model with reference to the embodiments.

[0011] As shown in Fig. 1 and 2, an electronic atomizer includes a housing 1 and a battery 5 disposed inside the housing, wherein a processing chip 2, a heating apparatus 3, and a sensing apparatus 4 are disposed inside the housing 1, the processing chip 1 is electrically connected to the battery 5, the heating apparatus 3, and the sensing apparatus 4, an airflow sensing switch circuit 21, a heating drive circuit 22, a

charging mode detection circuit 23, a battery charging and protection circuit 24, and a light-emitting diode drive circuit 25 are disposed in the processing chip 2, an output pin of the heating drive circuit 22 is connected to the heating apparatus 3, an output pin of the light-emitting diode drive circuit 25 is connected to a light-emitting diode D1, an input pin of the airflow sensing switch circuit 21 is connected to the sensing apparatus 4, one end of the charging mode detection circuit 23 and one end of the battery charging and protection circuit 24 are connected to the battery 5, and the other end is connected to a power input end. An opening to be used by the heating apparatus is disposed on the housing.

[0012] As shown in Fig. 1, an electronic serial interface 6 is disposed inside the housing 1, an opening to be used by the electronic serial interface is disposed inside the housing 1, and the electronic serial interface 6 is electrically connected to the processing chip 2. In this embodiment, the electronic serial interface 6 is a USB interface.

[0013] As shown in Fig. 2, a pin 1 of the processing chip 2 is set to an input pin of the airflow sensing switch circuit, a pin 2 is set to a grounding pin, a pin 3 is set to an output pin of the light-emitting diode drive circuit, a pin 4 is set to an output pin of the heating drive circuit, an input pin of the charging mode detection circuit, and an input pin of the battery charging and protection circuit, and a pin 5 is set to a power input pin.

[0014] A battery compartment is disposed inside the housing 1, and the battery is installed inside the battery compartment. A lithium battery is used as the battery in this embodiment.

[0015] The heating drive circuit 22 is configured to drive the heating apparatus 3, and the heating drive circuit 22 outputs a voltage to the heating apparatus 3 through pulse width modulation. The heating apparatus 3 lights a cigarette and atomizes liquid by generating heat. The heating apparatus 3 may be a heating wire, a heating resistor, or another material that generates heat by using electric energy. In this embodiment, the heating apparatus 3 is a heating wire.

[0016] The sensing apparatus 4 is a capacitive airflow sensor. The airflow sensing switch circuit 21 is configured to sense smoking actions of a user, and the circuit provides an airflow sensing function by detecting a capacitance value of an external capacitive airflow sensor C1. When the user smokes, an airflow is generated. When the airflow flows through the capacitive airflow sensor C1, the capacitance value of the capacitive airflow sensor C1 changes, thereby triggering the airflow sensing switch circuit 21.

[0017] As shown in Fig. 3, the processing chip is U1, a battery group is BT1, the sensing apparatus is C1, the heating apparatus is L1, and the light-emitting transistor is D1. One end of the capacitor C2 is connected to a pin 5 (BAT) of the processing chip U1, and the other end of the capacitor C2 is grounded. When the user smokes, an airflow is generated, and the airflow triggers the airflow sensing switch circuit 21 after passing through the capacitive airflow sensing apparatus C1. Then, the heating drive circuit 22 outputs a voltage to the heating apparatus L1 through PWM. High temperature and heat generated by the heating apparatus L1 are enough to atomize liquid that simulates cigarettes for inhalation by the user. During heating, the light-emitting diode drive circuit 25 also outputs a current to the light-emitting diode D1, to indicate that the heating apparatus L1 is heating. When the user stops smoking, the processing chip 2 immediately stops driving the heating apparatus L1 and the light-emitting diode D1.

[0018] If the user keeps smoking for more than five seconds, the processing chip 2 stops outputting the voltage to the heating apparatus L1 and flashes the light-emitting diode D1 several times to indicate that the heating time is too long.

[0019] When a voltage of the lithium battery is less than 3.2 V and after the user smokes to trigger the airflow sensing switch circuit 21, the processing chip 2 does not output the voltage to the heating apparatus L1 to heat up and flashes the light-emitting diode D1 several times to indicate that the voltage of the battery is too low. This can protect the battery 5 from excessively discharging.

[0020] The charging mode detection circuit 23 may detect whether the present utility model is in a battery charging mode or a normal heating mode, so that the battery can be normally charged or can normally atomize liquid. When a voltage of a fourth pin (OUT) of the processing chip 2 is higher than a voltage of the fifth pin

Explore Litigation Insights

Docket Alarm provides insights to develop a more informed litigation strategy and the peace of mind of knowing you're on top of things.

Real-Time Litigation Alerts



Keep your litigation team up-to-date with **real-time alerts** and advanced team management tools built for the enterprise, all while greatly reducing PACER spend.

Our comprehensive service means we can handle Federal, State, and Administrative courts across the country.

Advanced Docket Research



With over 230 million records, Docket Alarm's cloud-native docket research platform finds what other services can't. Coverage includes Federal, State, plus PTAB, TTAB, ITC and NLRB decisions, all in one place.

Identify arguments that have been successful in the past with full text, pinpoint searching. Link to case law cited within any court document via Fastcase.

Analytics At Your Fingertips



Learn what happened the last time a particular judge, opposing counsel or company faced cases similar to yours.

Advanced out-of-the-box PTAB and TTAB analytics are always at your fingertips.

API

Docket Alarm offers a powerful API (application programming interface) to developers that want to integrate case filings into their apps.

LAW FIRMS

Build custom dashboards for your attorneys and clients with live data direct from the court.

Automate many repetitive legal tasks like conflict checks, document management, and marketing.

FINANCIAL INSTITUTIONS

Litigation and bankruptcy checks for companies and debtors.

E-DISCOVERY AND LEGAL VENDORS

Sync your system to PACER to automate legal marketing.