

EXHIBIT A



US010420374B2

(12) **United States Patent**
Liu

(10) **Patent No.:** **US 10,420,374 B2**
(45) **Date of Patent:** **Sep. 24, 2019**

(54) **ELECTRONIC SMOKE APPARATUS**

(56) **References Cited**

(71) Applicant: **Altria Client Services LLC**,
Richmond, VA (US)

U.S. PATENT DOCUMENTS

2,200,863 A 5/1940 Hugo
2,907,320 A 10/1959 De Weese
(Continued)

(72) Inventor: **Loi Ying Liu**, Tsuen Wan (HK)

(73) Assignee: **Altria Client Services LLC**,
Richmond, VA (US)

FOREIGN PATENT DOCUMENTS

AU 2008351672 9/2009
CA 2169765 2/1995
(Continued)

(*) Notice: Subject to any disclaimer, the term of this patent is extended or adjusted under 35 U.S.C. 154(b) by 502 days.

OTHER PUBLICATIONS

(21) Appl. No.: **14/793,453**

International Search Report for PCT/IB2010/052949 dated Apr. 21, 2011.

(22) Filed: **Jul. 7, 2015**

(Continued)

(65) **Prior Publication Data**

US 2015/0305410 A1 Oct. 29, 2015

Primary Examiner — Matthew J Daniels

(74) *Attorney, Agent, or Firm* — Harness, Dickey & Pierce, P.L.C.

Related U.S. Application Data

(63) Continuation-in-part of application No. 13/131,705, filed as application No. PCT/IB2010/052949 on Jun. 29, 2010, now Pat. No. 9,072,321.

(57) **ABSTRACT**

An electronic smoke comprises a puff detection sub-assembly module. The puff detection sub-assembly comprises a first conductive surface, a second conductive surface and an insulated ring spacer separating the first and the second conductive surfaces at an effective separation distance. The first conductive surface, the second conductive surface and the insulated ring spacer are housed inside a metallic can. The first conductive surface is electrically connected to the metal can by a first conductive ring which is disposed between the first conductive surface and a ceiling portion of the metal can. The second conductive surface is electrically connected to an output terminal through a second conductive ring, the second conductive ring elevating the puff detection sub-assembly above a floor portion of the metal can and urging the first conductive ring against a ceiling portion of the metal can.

(30) **Foreign Application Priority Data**

Sep. 18, 2009 (CN) 2009 2 0179316 U

25 Claims, 15 Drawing Sheets

(51) **Int. Cl.**

A24F 47/00 (2006.01)

(52) **U.S. Cl.**

CPC *A24F 47/008* (2013.01)

(58) **Field of Classification Search**

CPC A24F 47/008; A24F 47/002; G01L 9/0072
See application file for complete search history.

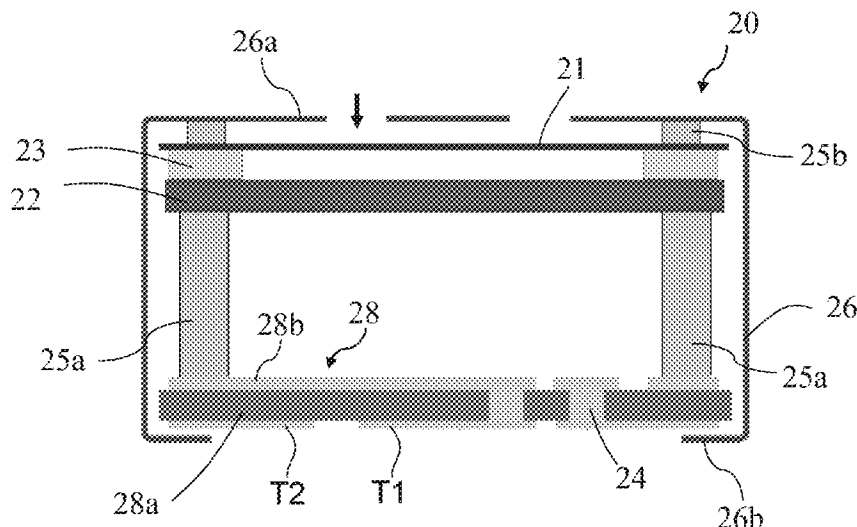

US 10,420,374 B2

Page 2

(56)

References Cited

U.S. PATENT DOCUMENTS			FOREIGN PATENT DOCUMENTS		
3,389,601	A	6/1968 Semplak	2005/0016550	A1	1/2005 Katase
3,534,728	A	10/1970 Barrows	2005/0081639	A1	4/2005 Gourlay
3,814,998	A	6/1974 Thoma et al.	2005/0172976	A1	8/2005 Newman et al.
3,946,726	A	3/1976 Pikul	2005/0229710	A1	10/2005 O'dowd et al.
3,965,746	A	6/1976 Rabek	2006/0196518	A1	9/2006 Hon
4,141,252	A	2/1979 Lodge	2007/0006889	A1	1/2007 Kobal et al.
4,206,644	A	6/1980 Platt	2007/0102013	A1	5/2007 Adams et al.
4,484,479	A	11/1984 Eckhardt	2008/0173303	A1	7/2008 McLaughlin et al.
4,488,439	A	12/1984 Gast et al.	2009/0095311	A1	4/2009 Han
4,490,773	A	12/1984 Mofatt	2010/0200008	A1	8/2010 Taieb
4,599,907	A	7/1986 Kraus et al.	2010/0242974	A1*	9/2010 Pan A24F 47/008 131/273
4,876,892	A	10/1989 Arabia et al.	2011/0011396	A1	1/2011 Fang
4,922,901	A	5/1990 Brooks et al.	2011/0075863	A1*	3/2011 Rosen H04R 19/04 381/111
4,945,929	A	8/1990 Egilmex	2011/0155151	A1	6/2011 Newman et al.
5,107,860	A	4/1992 Malouvier et al.	2011/0226236	A1	9/2011 Buchberger
5,134,886	A	8/1992 Ball	2011/0277780	A1	11/2011 Terry et al.
5,146,435	A *	9/1992 Bernstein G01H 11/06 29/25.42	2011/0304282	A1	12/2011 Li et al.
5,388,594	A	2/1995 Counts et al.	2012/0090630	A1	4/2012 Hon
5,665,262	A	9/1997 Hajaligol et al.	2012/0118301	A1	5/2012 Montaser
5,666,977	A	9/1997 Higgins et al.	2012/0234315	A1	9/2012 Li et al.
5,692,525	A	12/1997 Counts et al.	2012/0273589	A1	11/2012 Hon
5,692,526	A	12/1997 Adams et al.	2013/0139833	A1	6/2013 Hon
5,902,501	A	5/1999 Nunnally et al.	2013/0283885	A1	10/2013 Lee
5,934,289	A	8/1999 Watkins et al.	2014/0150810	A1	6/2014 Hon
5,959,219	A	9/1999 Saunders	2014/0246020	A1	9/2014 Minskoff et al.
5,988,176	A	11/1999 Baggett, Jr. et al.	2014/0299137	A1	10/2014 Kieckbusch et al.
6,040,560	A	3/2000 Fleischhauer et al.	2015/0020825	A1	1/2015 Galloway et al.
6,615,840	B1	9/2003 Fournier et al.	2015/0020831	A1	1/2015 Weigensborg et al.
6,803,545	B2	10/2004 Blake et al.	2015/0020833	A1	1/2015 Conley et al.
6,803,550	B2	10/2004 Sharpe et al.	2015/0040930	A1	2/2015 Robinson et al.
6,810,883	B2	11/2004 Felter et al.	2015/0047656	A1	2/2015 Robinson et al.
7,171,012	B2	1/2007 Izuchi et al.	2015/0053214	A1	2/2015 Alarcon et al.
7,353,711	B2	4/2008 O'down et al.	2015/0053217	A1	2/2015 Steingraber et al.
7,726,320	B2	6/2010 Robinson et al.	2015/0128974	A1	3/2015 Alarcon et al.
7,832,410	B2	11/2010 Hon	2015/0150306	A1	5/2015 Hon
7,845,359	B2	12/2010 Montaser	2015/0150306	A1	6/2015 Chen
8,079,371	B2	12/2011 Robinson et al.	2015/0272224	A1	10/2015 Hon
8,091,558	B2	1/2012 Martzel	2015/0366267	A1	12/2015 Liu
8,127,772	B2	3/2012 Montaser	2016/0021930	A1	1/2016 Minskoff et al.
8,156,944	B2	4/2012 Han	2016/0073691	A1	3/2016 Liu
8,205,622	B2	6/2012 Pan	2016/0213067	A1	7/2016 Hon
8,314,591	B2	11/2012 Terry et al.	2016/0213068	A1	7/2016 Hon
8,365,742	B2	2/2013 Hon	2016/0255878	A1	9/2016 Huang et al.
8,375,957	B2	2/2013 Hon	2016/0270448	A1	9/2016 Hon
8,393,331	B2	3/2013 Hon	2016/0270449	A1	9/2016 Hon
8,490,628	B2	7/2013 Hon	2016/0270450	A1	9/2016 Hon
8,511,318	B2	8/2013 Hon	2016/0270451	A1	9/2016 Hon
8,550,068	B2	10/2013 Terry et al.	2016/0286865	A1	10/2016 King et al.
8,689,805	B2	4/2014 Hon			
8,746,240	B2	6/2014 Terry et al.	CN	1040914	4/1990
8,863,752	B2	10/2014 Hon	CN	1530041	9/2004
8,863,753	B2	10/2014 Li et al.	CN	2643681	9/2004
8,893,726	B2	11/2014 Hon	CN	1541577	A 11/2004
8,897,628	B2	11/2014 Conley et al.	CN	2719043	Y 8/2005
8,899,238	B2	12/2014 Robinson et al.	CN	1717186	1/2006
8,899,239	B2	12/2014 Hon	CN	1741684	3/2006
8,910,641	B2	12/2014 Hon	CN	1791790	6/2006
9,072,321	B2*	7/2015 Liu A24F 47/008	CN	1284493	11/2006
9,259,035	B2	2/2016 Terry et al.	CN	1864054	11/2006
9,320,300	B2	4/2016 Hon	CN	201051862	Y 4/2008
9,326,548	B2	5/2016 Hon	CN	201054788	4/2008
9,326,549	B2	5/2016 Hon	CN	201054789	4/2008
9,326,550	B2	5/2016 Hon	CN	201054977	Y 5/2008
9,326,551	B2	5/2016 Hon	CN	101228969	A 7/2008
9,339,062	B2	5/2016 Hon	CN	101366554	A 2/2009
9,364,027	B2	6/2016 Hon	CN	201199922	3/2009
9,370,205	B2	6/2016 Hon	CN	201238610	Y 5/2009
9,439,455	B2	9/2016 Alarcon et al.	CN	101518361	9/2009
9,456,632	B2	10/2016 Hon	CN	101518361	A 9/2009
2002/0005207	A1	1/2002 Wrenn et al.	CN	101524187	9/2009
2002/0123669	A1	9/2002 Wickstrom	CN	101524187	A 9/2009
2004/0129280	A1	7/2004 Woodson et al.	CN	101606758	A 12/2009
2004/0187589	A1	9/2004 Ferran	CN	201490998	5/2010
2004/0200488	A1	10/2004 Felter et al.	CN	102227175	A 6/2010
			CN	201514238	6/2010

(56)

References Cited

FOREIGN PATENT DOCUMENTS

CN	1864054	8/2012
CN	103251133 A	8/2013
CN	203314104	12/2013
CN	203913376	11/2014
CN	203952419	11/2014
CN	204070537	1/2015
CN	204232300	4/2015
CN	105476069 A	4/2016
CN	105876869 A	8/2016
EP	0358114 A2	3/1990
EP	0488488 A1	6/1992
EP	0592173	4/1994
GB	1252433	11/1971
JP	63271121	11/1988
JP	H0348166	3/1991
JP	H6-117890	4/1994
JP	09005191	1/1997
JP	H09113326	5/1997
JP	11351921	12/1999
JP	2004163221	6/2004
JP	2005-034021	2/2005
JP	2005-265432	9/2005
JP	2007-010484	1/2007
JP	2009-066142	4/2009
JP	2013-526834	6/2013
JP	2014-521961	8/2014
KR	102005010773	11/2005
WO	WO-1992007599	5/1992
WO	WO-03012565	2/2003
WO	WO-2004/043175 A1	5/2004
WO	WO2004/080216 A1	9/2004
WO	WO-2004/086457	10/2004
WO	WO-2005/019785	3/2005
WO	WO-2007/131449 A1	11/2007
WO	WO-2008108889	9/2008
WO	WO-2009005211	1/2009
WO	WO-2010045671	4/2010
WO	WO-2011033396 A2	3/2011
WO	WO-2015089711	6/2015

OTHER PUBLICATIONS

Wei, Ze-Wen et al., "A Novel 2-D Capacitive Silicon Flow Sensor", IEEE Sensors 2007 conference, 2007.

Wolfgang Demtroder, "Experimentalphysik1 Mechanik and Wärme", Springer-Verlag Berlin Heidelberg, 3rd edition, 2003.

Jin Hai Xu, "Capacitive Pressure; Microsensor and Wireless Measurement System Thereof", Thesis for Master Degree of Xiamen University, Xu Jinhai May 20, 2010.

Notice of Opposition dated Jul. 7, 2017 in European Patent No. 2477514.

Response to Notice of Opposition filed Mar. 8, 2018 in European Patent No. 2477514.

Examination Decision of Invalidation Request No. 26243 dated Jun. 23, 2015 in Chinese Application or Patent No. 201080003430.9 (or Document Issuance No. 2015061700379090).

Examination Decision of Invalidation Request No. 28219 dated Feb. 6, 2016 in Chinese Application or Patent No. 201080003430.9 (or Document Issuance No. 2016020300672460).

Xu Zhou, "Modern Sensor Technologies", the National Defense Industry Press, Jan. 2007, the 1st Ed. and the 1st Print, Beijing, China.

"Handbook of Flow Measurement", the China Metrology Publishing House, the 1st Ed. Published and First Printed in Feb. 1982 in China.

"Non Contacting Measurement Method and Technology of Pipe Flow", the China Metrology Publishing House, version 1, Published and First Printed in Jan. 1999, in China.

Datasheet for Honeywell AWM 2100V Airflow Sensor. "Installation Instructions for the AWM2000 Series", Issue 3 PK 88544, (2003). Administrative Written Judgment issued Dec. 18, 2018 in Chinese Patent No. 201080003430.9.

Brief Communication issued Feb. 8, 2019 regarding Letter from the Opponent filed Feb. 1, 2019 in European Application No. 10816778.4.

Summons to attend oral proceedings pursuant to Rule 115(1) issued on Sep. 3, 2018 in European Patent Application No. 10816778.4. Office Action dated Jul. 1, 2013 in Chinese Patent Application No. 201210118301.5.

Office Action dated Mar. 3, 2014 in Chinese Patent Application No. 201210118301.5.

Office Action dated Aug. 13, 2014 in Chinese Patent Application No. 201210118301.5.

Notification to Grant Patent Right for Invention dated Nov. 4, 2014 in Chinese Patent Application No. 201210118301.5.

English Translation of Search Report dated Jun. 24, 2013 in Chinese Patent Application No. 201210118301.5.

English Translation of Search Report dated Jun. 9, 2013 in Chinese Patent Application No. 201210118451.6.

Office Action dated Jun. 28, 2013 in Chinese Patent Application No. 201210118451.6.

Office Action dated Feb. 8, 2014 in Chinese Patent Application No. 201210118451.6.

Office Action dated Jul. 22, 2014 in Chinese Patent Application No. 201210118451.6.

Notification to Grant Patent Right for Invention dated Nov. 24, 2014 in Chinese Patent Application No. 201210118451.6.

English Translation of Search Report dated Dec. 19, 2011 in Chinese Patent Application No. 201080003430.9.

Office Action dated Dec. 23, 2011 in Chinese Patent Application No. 201080003430.9.

Notification to Grant Patent Right for Invention dated Feb. 6, 2012 in Chinese Patent Application No. 201080003430.9.

Office Action dated Jan. 7, 2014 in Japanese Patent Application No. 2012-529362.

Decision to Grant a Patent dated Sep. 30, 2014 in Japanese Patent Application No. 2012-529362.

Extended European Search Report dated Jan. 22, 2015 in European Patent Application No. 10816778.4.

Communication pursuant to Article 94(3) dated Nov. 2, 2015 in European Patent Application No. 10816778.4.

Decision to grant a European patent dated Aug. 25, 2016 in European Patent Application No. 10816778.4.

International Preliminary Report on Patentability dated Mar. 20, 2012 in International Application No. PCT/IB2010/052949.

Non-Final Office Action dated Jun. 30, 2014 in U.S. Appl. No. 13/131,705.

Final Office Action dated Mar. 11, 2015 in U.S. Appl. No. 13/131,705.

Notice of Allowance dated May 20, 2015 in U.S. Appl. No. 13/131,705.

Letter regarding the opposition procedure issued Nov. 16, 2017 in European Patent Application No. 10816778.4.

* cited by examiner

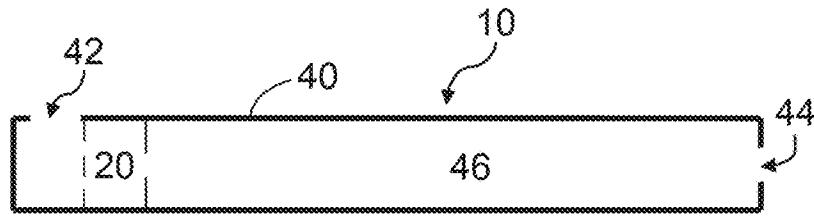

Figure 1

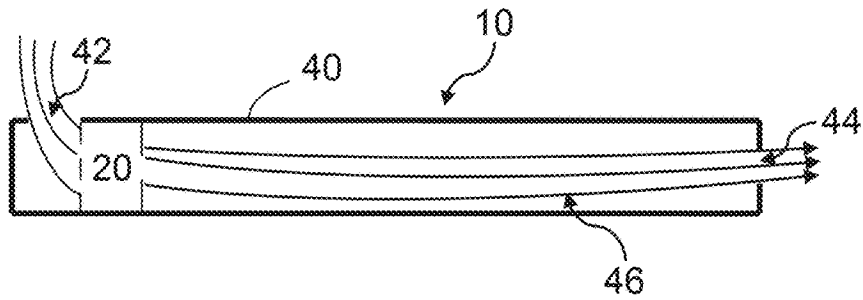

Figure 1A

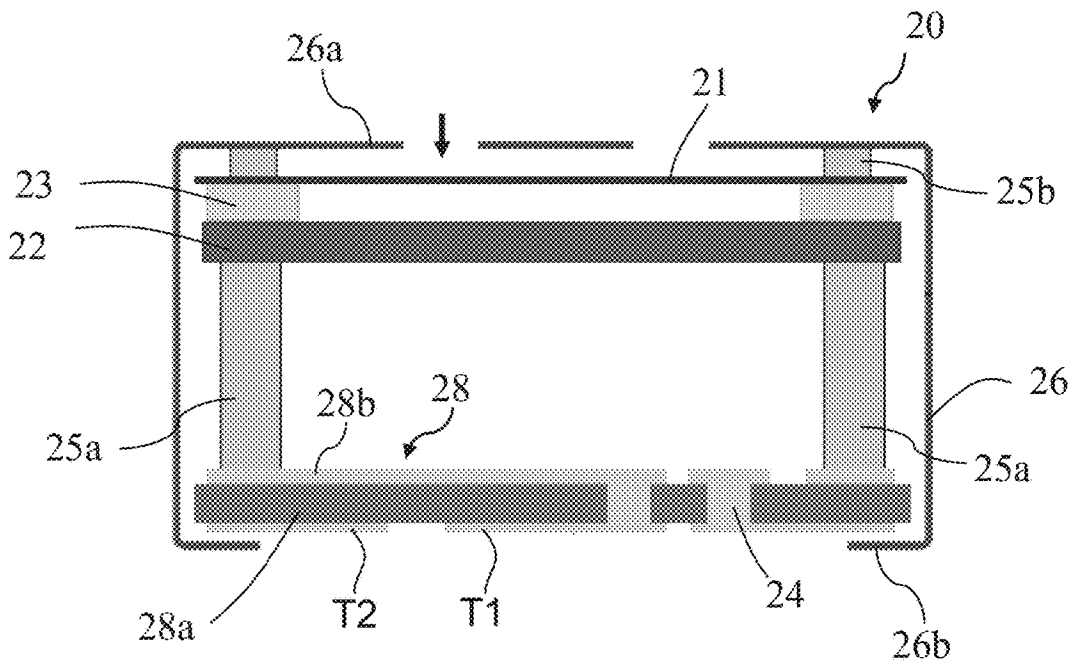

Figure 2

Explore Litigation Insights

Docket Alarm provides insights to develop a more informed litigation strategy and the peace of mind of knowing you're on top of things.

Real-Time Litigation Alerts



Keep your litigation team up-to-date with **real-time alerts** and advanced team management tools built for the enterprise, all while greatly reducing PACER spend.

Our comprehensive service means we can handle Federal, State, and Administrative courts across the country.

Advanced Docket Research



With over 230 million records, Docket Alarm's cloud-native docket research platform finds what other services can't. Coverage includes Federal, State, plus PTAB, TTAB, ITC and NLRB decisions, all in one place.

Identify arguments that have been successful in the past with full text, pinpoint searching. Link to case law cited within any court document via Fastcase.

Analytics At Your Fingertips



Learn what happened the last time a particular judge, opposing counsel or company faced cases similar to yours.

Advanced out-of-the-box PTAB and TTAB analytics are always at your fingertips.

API

Docket Alarm offers a powerful API (application programming interface) to developers that want to integrate case filings into their apps.

LAW FIRMS

Build custom dashboards for your attorneys and clients with live data direct from the court.

Automate many repetitive legal tasks like conflict checks, document management, and marketing.

FINANCIAL INSTITUTIONS

Litigation and bankruptcy checks for companies and debtors.

E-DISCOVERY AND LEGAL VENDORS

Sync your system to PACER to automate legal marketing.