

EXHIBIT 12



US008933945B2

(12) **United States Patent**
Leather et al.

(10) **Patent No.:** **US 8,933,945 B2**
(45) **Date of Patent:** **Jan. 13, 2015**

(54) **DIVIDING WORK AMONG MULTIPLE GRAPHICS PIPELINES USING A SUPER-TILING TECHNIQUE**

(75) Inventors: **Mark M. Leather**, Saratoga, CA (US);
Eric Demers, Palo Alto, CA (US)

(73) Assignee: **ATI Technologies ULC**, Markham,
Ontario (CA)

(*) Notice: Subject to any disclaimer, the term of this patent is extended or adjusted under 35 U.S.C. 154(b) by 1808 days.

(21) Appl. No.: **10/459,797**

(22) Filed: **Jun. 12, 2003**

(65) **Prior Publication Data**

US 2004/0100471 A1 May 27, 2004

Related U.S. Application Data

(60) Provisional application No. 60/429,641, filed on Nov. 27, 2002.

(51) **Int. Cl.**

G06T 1/20 (2006.01)
G06F 13/14 (2006.01)
G06F 12/02 (2006.01)
G06T 11/40 (2006.01)
G06T 15/00 (2011.01)
G09G 5/36 (2006.01)

(52) **U.S. Cl.**

CPC . **G06T 11/40** (2013.01); **G06T 1/20** (2013.01);
G06T 15/005 (2013.01); **G09G 5/363** (2013.01)
USPC **345/506**; **345/519**; **345/544**

(58) **Field of Classification Search**

USPC **345/506**, **530**, **505**, **588**, **544**, **545**, **532**,
345/501, **502**, **531**, **519**

See application file for complete search history.

(56) **References Cited**

U.S. PATENT DOCUMENTS

4,885,703 A 12/1989 Deering
5,179,640 A * 1/1993 Duffy 345/596
5,550,962 A 8/1996 Nakamura et al.
5,745,118 A * 4/1998 Alcorn et al. 345/587
5,794,016 A * 8/1998 Kelleher 345/505
5,818,469 A 10/1998 Lawless et al.
5,905,506 A * 5/1999 Hamburg 345/672
5,977,997 A 11/1999 Vainsencher
5,999,196 A 12/1999 Storm et al.
6,118,452 A 9/2000 Gannett

(Continued)

OTHER PUBLICATIONS

Elias, Hugo. "Polygon Scan Converting." http://freespace.virgin.net/hugo.elias/graphics/x_polysc.htm.*

(Continued)

Primary Examiner — Joni Richer

(74) Attorney, Agent, or Firm — Faegre Baker Daniels LLP

(57) **ABSTRACT**

A graphics processing circuit includes at least two pipelines operative to process data in a corresponding set of tiles of a repeating tile pattern, a respective one of the at least two pipelines operative to process data in a dedicated tile, wherein the repeating tile pattern includes a horizontally and vertically repeating pattern of square regions. A graphics processing method includes receiving vertex data for a primitive to be rendered; generating pixel data in response to the vertex data; determining the pixels within a set of tiles of a repeating tile pattern to be processed by a corresponding one of at least two graphics pipelines in response to the pixel data, the repeating tile pattern including a horizontally and vertically repeating pattern of square regions; and performing pixel operations on the pixels within the determined set of tiles by the corresponding one of the at least two graphics pipelines.

21 Claims, 5 Drawing Sheets

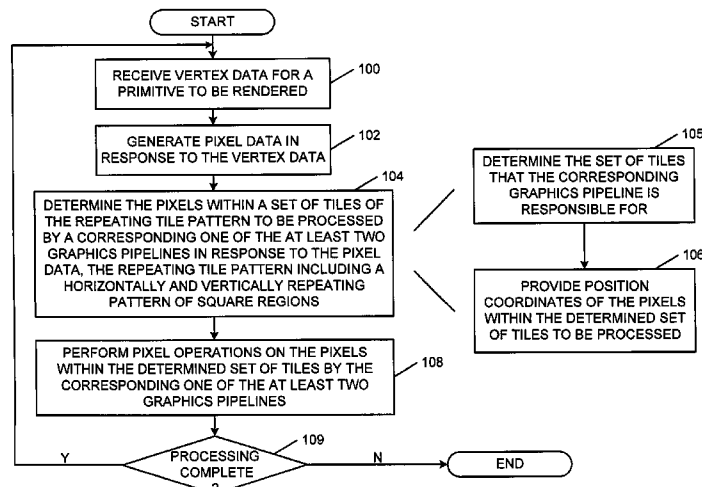

(56)

References Cited

U.S. PATENT DOCUMENTS

6,184,906 B1* 2/2001 Wang et al. 345/532
 6,219,062 B1 4/2001 Matsuo et al.
 6,222,550 B1 4/2001 Rosman et al.
 6,292,200 B1 9/2001 Bowen et al.
 6,323,860 B1 11/2001 Zhu et al.
 6,344,852 B1 2/2002 Zhu et al.
 6,353,439 B1 3/2002 Lindholm et al.
 6,380,935 B1 4/2002 Heeschen et al.
 6,384,824 B1 5/2002 Morgan et al.
 6,407,736 B1 6/2002 Regan
 6,417,858 B1 7/2002 Bosch et al.
 6,424,345 B1 7/2002 Smith et al.
 6,557,083 B1 4/2003 Sperber et al.
 6,570,579 B1* 5/2003 MacInnis et al. 345/629
 6,573,893 B1 6/2003 Naqvi et al.
 6,636,232 B2 10/2003 Larson
 6,650,327 B1 11/2003 Airey et al.
 6,650,330 B2 11/2003 Lindholm et al.
 6,697,063 B1 2/2004 Zhu
 6,714,203 B1* 3/2004 Morgan et al. 345/506
 6,724,394 B1 4/2004 Zatz et al.
 6,731,289 B1 5/2004 Peercy et al.
 6,750,867 B1 6/2004 Gibson
 6,753,878 B1* 6/2004 Heirich et al. 345/629
 6,762,763 B1* 7/2004 Migdal et al. 345/506
 6,778,177 B1* 8/2004 Furtner 345/544
 6,791,559 B2 9/2004 Baldwin
 6,801,203 B1 10/2004 Hussain
 6,809,732 B2 10/2004 Zatz et al.
 6,864,893 B2 3/2005 Zatz
 6,864,896 B2* 3/2005 Perego 345/542
 6,897,871 B1 5/2005 Morein et al.
 6,980,209 B1 12/2005 Donham et al.

7,015,913 B1 3/2006 Lindholm et al.
 7,061,495 B1 6/2006 Leather
 7,170,515 B1 1/2007 Zhu
 2002/0145612 A1 10/2002 Blythe et al.
 2003/0076320 A1 4/2003 Collodi
 2003/0164830 A1* 9/2003 Kent 345/505
 2004/0041814 A1 3/2004 Wyatt et al.
 2004/0164987 A1 8/2004 Aronson et al.
 2005/0068325 A1 3/2005 Lefebvre et al.
 2005/0200629 A1 9/2005 Morein et al.
 2006/0170690 A1 8/2006 Leather

OTHER PUBLICATIONS

European Search Report from European Patent Office; European Application No. 03257464.2; dated Apr. 4, 2006.
 Foley, James et al.; Computer Graphics, Principles and Practice; Addison-Wesley Publishing Company; 1990; pp. 873-899.
 Crockett, Thomas W.; An introduction to parallel rendering; Elsevier Science B.V.; 1997; pp. 819-843.
 Montrym, John S. et al.; InfiniteReality: A Real-Time Graphics System; Silicon Graphics Computer Systems; 1997; pp. 293-302.
 Humphreys, Greg et al.; WireGL: A Scalable Graphics System for Clusters; ACM Siggraph; 2001; pp. 129-140.
 Akeley, K. et al.; High-Performance Polygon Rendering; ACM Computer Graphics; vol. 22, No. 4; 1988; pp. 239-246.
 Breternitz, Jr., Mauricio et al.; Compilation, Architectural Support, and Evaluation of SIMD Graphics Pipeline Programs on a General-Purpose CPU; IEEE; 2003; pp. 1-11.
 International Search Report for PCT Patent Application PCT/IB2004/003821 dated Mar. 22, 2005.
 Fuchs, Henry et al.; Pixel-Planes 5: A Heterogeneous Multiprocessor Graphics System Using Processor-Enhanced Memories; Computer Graphics; vol. 23, No. 3; Jul. 1989; pp. 79-88.

* cited by examiner

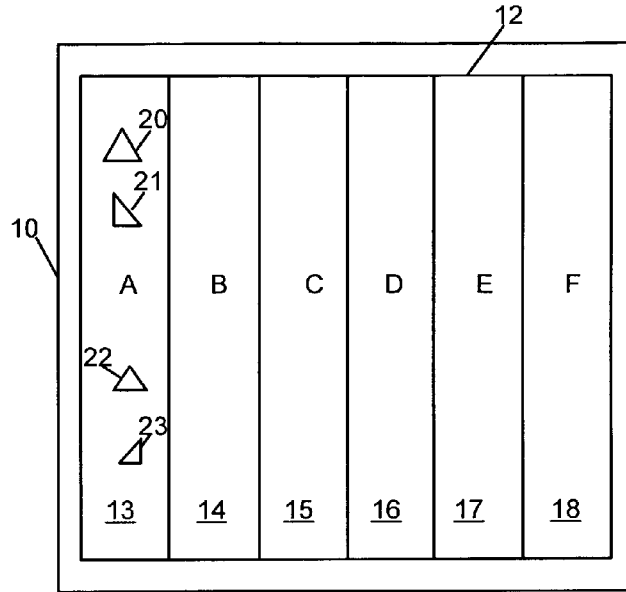

FIG. 1
PRIOR ART

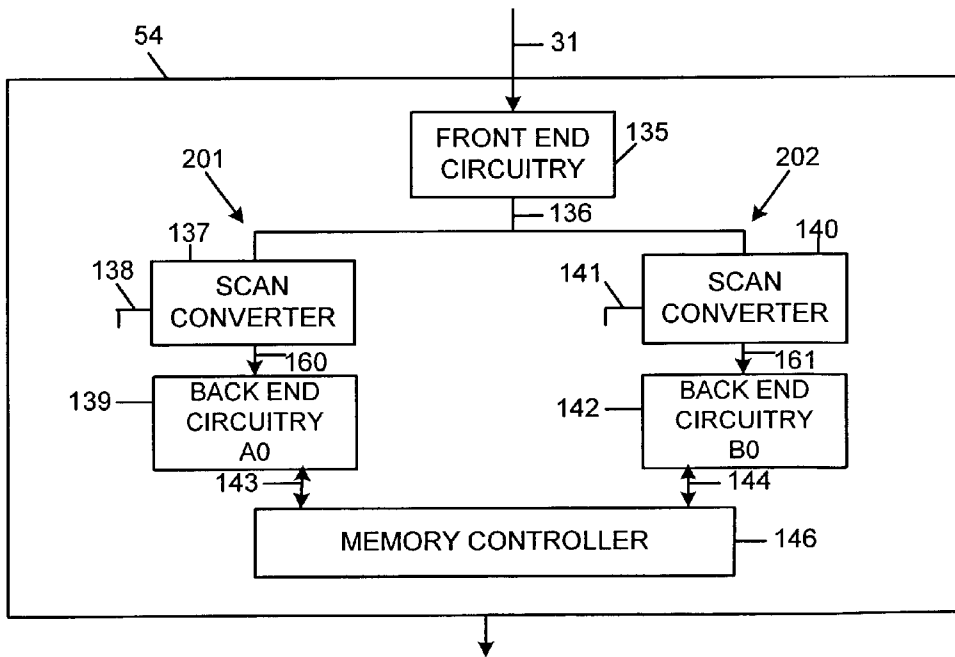

FIG. 5

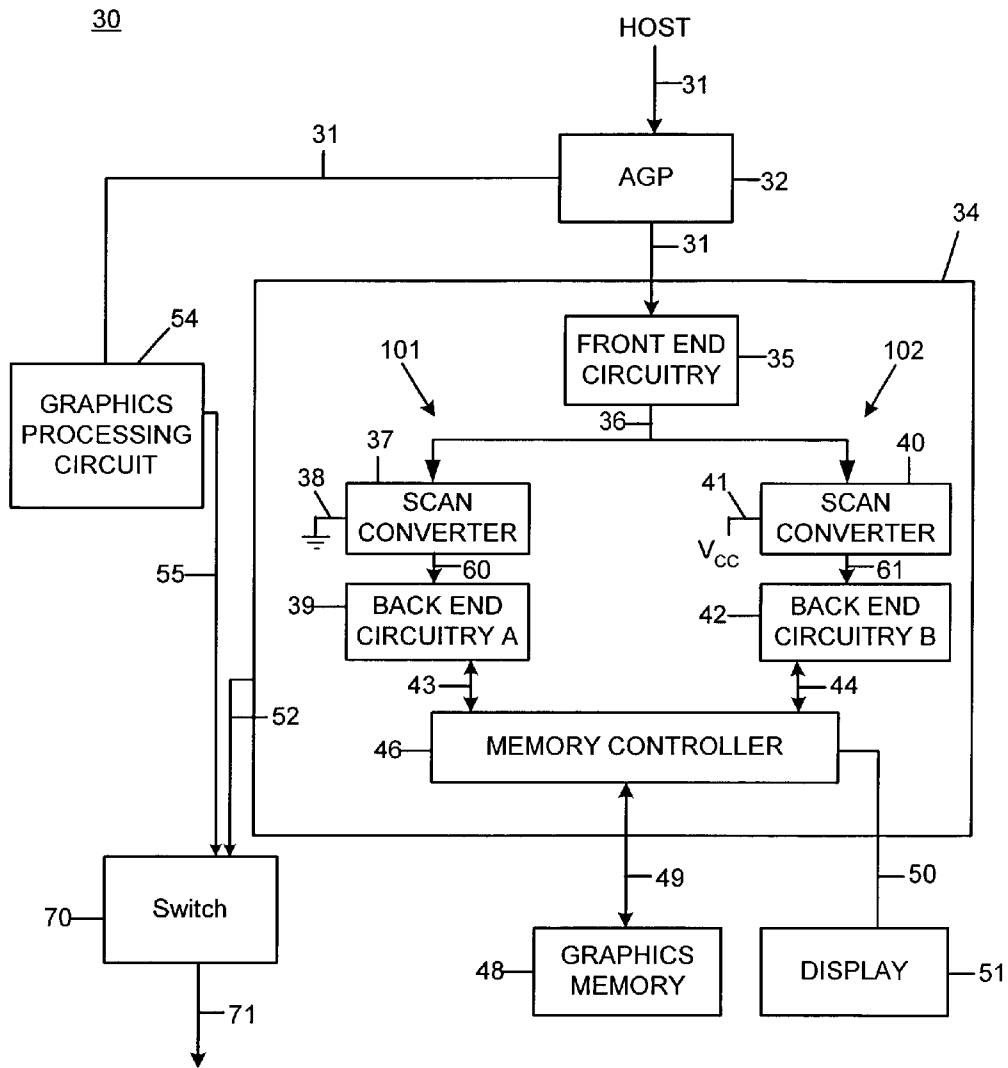

FIG. 2

Explore Litigation Insights

Docket Alarm provides insights to develop a more informed litigation strategy and the peace of mind of knowing you're on top of things.

Real-Time Litigation Alerts



Keep your litigation team up-to-date with **real-time alerts** and advanced team management tools built for the enterprise, all while greatly reducing PACER spend.

Our comprehensive service means we can handle Federal, State, and Administrative courts across the country.

Advanced Docket Research



With over 230 million records, Docket Alarm's cloud-native docket research platform finds what other services can't. Coverage includes Federal, State, plus PTAB, TTAB, ITC and NLRB decisions, all in one place.

Identify arguments that have been successful in the past with full text, pinpoint searching. Link to case law cited within any court document via Fastcase.

Analytics At Your Fingertips



Learn what happened the last time a particular judge, opposing counsel or company faced cases similar to yours.

Advanced out-of-the-box PTAB and TTAB analytics are always at your fingertips.

API

Docket Alarm offers a powerful API (application programming interface) to developers that want to integrate case filings into their apps.

LAW FIRMS

Build custom dashboards for your attorneys and clients with live data direct from the court.

Automate many repetitive legal tasks like conflict checks, document management, and marketing.

FINANCIAL INSTITUTIONS

Litigation and bankruptcy checks for companies and debtors.

E-DISCOVERY AND LEGAL VENDORS

Sync your system to PACER to automate legal marketing.