

EXHIBIT

4

Fifth Edition

P rinciples of Electric Circuits

FLOYD

Library of Congress Cataloging-Publication Data

Floyd, Thomas L.
Principles of electric circuits / Thomas L. Floyd.—5th ed.
p. cm.
Includes index.
ISBN 0-13-232224-2
1. Electric circuits. I. Title.
TK454.F57 1997
621.3815—dc20 96-13443
CIP

Cover photo: © Superstock
Editor: Linda Ludewig
Developmental Editor: Carol Hinklin Robison
Production Editor: Rex Davidson
Text Designer: Anne Flanagan
Cover Designer: Brian Deep
Production Buyer: Patricia A. Tonneman
Marketing Manager: Debbie Yarnell
Illustrations: Jane Lopez and Steve Botts

This book was set in Times Roman by The Clarinda Company and was printed and bound by Von Hoffmann Press, Inc. The cover was printed by Von Hoffmann Press, Inc.



© 1997, 1993 by Prentice-Hall, Inc.
Simon & Schuster/A Viacom Company
Upper Saddle River, New Jersey 07458

All rights reserved. No part of this book may be reproduced, in any form or by any means, without permission in writing from the publisher.

Earlier editions © 1989, 1985, 1981 by Merrill Publishing Company

Printed in the United States of America

10 9 8 7 6 5 4 3 2 1

ISBN 0-13-232224-2

Prentice-Hall International (UK) Limited, *London*
Prentice-Hall of Australia Pty. Limited, *Sydney*
Prentice-Hall Canada Inc., *Toronto*
Prentice-Hall Hispanoamericana, S. A., *Mexico*
Prentice-Hall of India Private Limited, *New Delhi*
Prentice-Hall of Japan, Inc., *Tokyo*
Simon & Schuster Asia Pte. Ltd., *Singapore*
Editora Prentice-Hall do Brasil, Ltda., *Rio de Janeiro*

EXAMPLE 2-1

How many coulombs do 93.75×10^{16} electrons represent?

Solution

$$Q = \frac{\text{number of electrons}}{6.25 \times 10^{18} \text{ electrons/C}} = \frac{93.75 \times 10^{16} \text{ electrons}}{6.25 \times 10^{18} \text{ electrons/C}} = 15 \times 10^{-2} \text{ C} = 0.15 \text{ C}$$

Related Exercise How many electrons does it take to have 3 C of charge?

**SECTION 2-2
REVIEW**

1. What is the symbol for charge?
2. What is the unit of charge, and what is the unit symbol?
3. What causes positive and negative charge?
4. How much charge, in coulombs, is there in 10×10^{12} electrons?

2-3 ■ VOLTAGE

As you have seen, a force of attraction exists between a positive and a negative charge. A certain amount of energy must be exerted in the form of work to overcome the force and move the charges a given distance apart. All opposite charges possess a certain potential energy because of the separation between them. The difference in potential energy of the charges is the potential difference or voltage. Voltage is the driving force in electric circuits and is what establishes current.

After completing this section, you should be able to

- Define voltage and discuss its characteristics
 - State the formula for voltage
 - Name and define the unit of voltage
 - Describe basic sources of voltage

Consider a water tank that is supported several feet above the ground. A given amount of energy must be exerted in the form of work to pump water up to fill the tank. Once the water is stored in the tank, it has a certain potential energy which, if released, can be used to perform work. For example, the water can be allowed to fall down a chute to turn a water wheel.

The difference in potential energy in electrical terms is called **voltage** (V) and is expressed as energy or work (W) per unit charge (Q).

$$V = \frac{W}{Q} \quad (2-2)$$

where W is expressed in **joules** (J) and Q is in coulombs (C).

Volt: The Unit of Voltage

The unit of voltage is the **volt**, symbolized by V.

One volt is the potential difference (voltage) between two points when one joule of energy is used to move one coulomb of charge from one point to the other.

2-6 ■ THE ELECTRIC CIRCUIT

A basic electric circuit is an arrangement of physical components which use voltage, current, and resistance to perform some useful function.

After completing this section, you should be able to

■ Describe a basic electric circuit

- Relate a schematic to a physical circuit
 - Define *open circuit* and *closed circuit*
 - Describe various types of protective devices
 - Describe various types of switches
 - Explain how wire sizes are related to gage numbers
 - Define *ground*
-

Direction of Current

For a few years after the discovery of electricity, people assumed all current consisted of moving positive charges. However, in the 1890s, the electron was identified as the charge carrier for current in conductive materials.

Today, there are two accepted conventions for the direction of electrical current. *Electron flow direction*, preferred by many in the fields of electrical and electronics technology, assumes for analysis purposes that current is out of the negative terminal of a voltage source, through the circuit, and into the positive terminal of the source. *Conventional current direction* assumes for analysis purposes that current is out of the positive terminal of a voltage source, through the circuit, and into the negative terminal of the source. By following the direction of conventional current, there is a rise in voltage across a source (negative to positive) and a drop in voltage across a resistor (positive to negative).

It actually makes no difference which direction of current is assumed as long as it is used *consistently*. The results of electric circuit analysis are not affected by the direction of current that is assumed for analytical purposes. The direction used for analysis is largely a matter of preference, and there are many proponents for each approach.

Conventional current direction is used widely in electronics technology and is used almost exclusively at the engineering level. Conventional current direction is used throughout this text. An alternate version of this text that uses electron flow direction is also available.

The Basic Circuit

Basically, an electric **circuit** consists of a voltage source, a load, and a path for current between the source and the **load**. Figure 2-26 shows in pictorial form an example of a simple electric circuit: a battery connected to a lamp with two conductors (wires). The battery is the voltage source, the lamp is the load on the battery because it draws current from the battery, and the two wires provide the current path from the positive terminal of the battery to the lamp and back to the negative terminal of the battery, as shown in part (b). Current goes through the filament of the lamp (which has a resistance), causing it to emit visible light. Current through the battery occurs by chemical action. In many practical cases, one terminal of the battery is connected to a common or ground point. For example, in most automobiles, the negative battery terminal is connected to the metal chassis of the car. The chassis is the ground for the automobile electrical system and acts as a conductor which completes the circuit.

40 ■ VOLTAGE, CURRENT, AND RESISTANCE

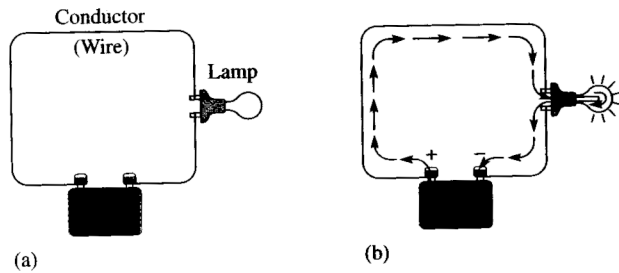

FIGURE 2-26
A simple electric circuit.



FIGURE 2-27
Schematic for the circuit in Figure 2-26(a).

The Electric Circuit Schematic

An electric circuit can be represented by a **schematic** using standard symbols for each element, as shown in Figure 2-27 for the simple circuit in Figure 2-26(a). The purpose of a schematic is to show in an organized manner how the various components in a given circuit are interconnected so that the operation of the circuit can be determined.

Closed and Open Circuits

The example circuit in Figure 2-26 illustrated a **closed circuit**—that is, a circuit in which the current has a complete path. When the current path is broken, the circuit is called an **open circuit**.

Switches Switches are commonly used for controlling the opening or closing of circuits by either mechanical or electronic means. For example, a switch is used to turn a lamp on or off as illustrated in Figure 2-28. Each circuit pictorial is shown with its associated schematic. The type of switch indicated is a single-pole-single-throw (SPST) toggle switch.

Figure 2-29 shows a somewhat more complicated circuit using a single-pole-double-throw (SPDT) type of switch to control the current to two different lamps. When one lamp is on, the other is off, and vice versa, as illustrated by the two schematics in parts (b) and (c), which represent each of the switch positions.

FIGURE 2-28
Basic closed and open circuits using an SPST switch for control.

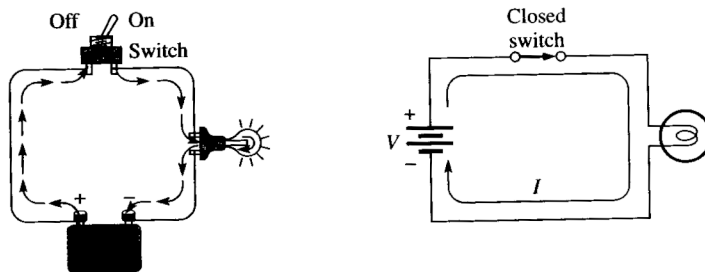

(a) There is current in a closed circuit (switch is ON or in the closed position).

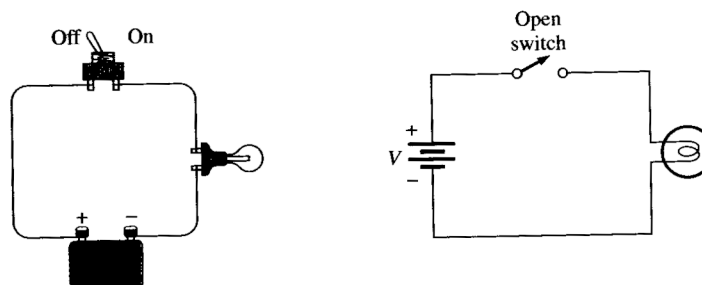

(b) There is no current in an open circuit (switch is OFF or in the open position).

- An ohmmeter is connected across a resistor (resistor must be removed from circuit).
- One coulomb is the charge of 6.25×10^{18} electrons.
- One volt is the potential difference (voltage) between two points when one joule of energy is used to move one coulomb from one point to the other.
- One ampere is the amount of current that exists when one coulomb of charge moves through a given cross-sectional area of a material in one second.
- One ohm is the resistance when there is one ampere of current in a material with one volt applied across the material.
- Figure 2-53 shows the electrical symbols introduced in this chapter.

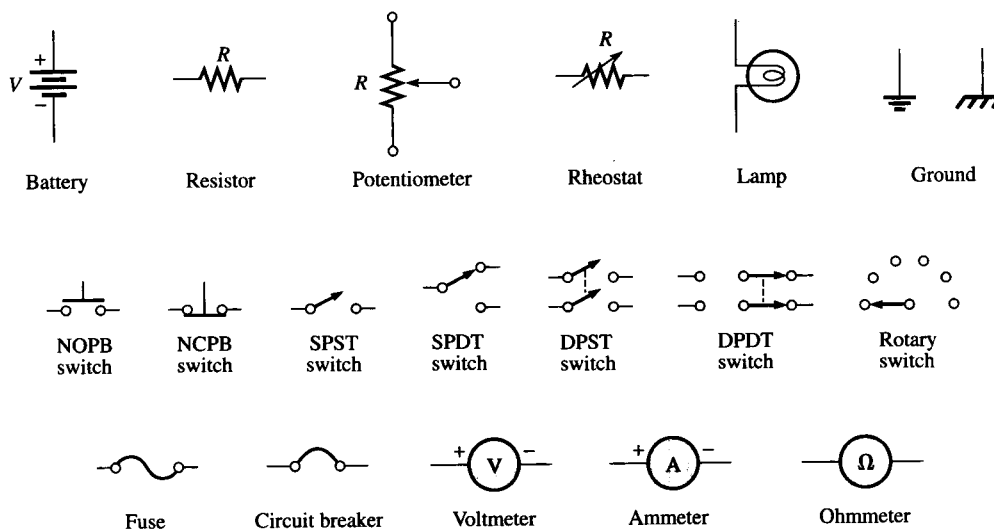

FIGURE 2-53

■ GLOSSARY

- American wire gage (AWG)** A standardization based on wire diameter.
- Ammeter** An electrical instrument used to measure current.
- Ampere (A)** The unit of electrical current.
- Atom** The smallest particle of an element possessing the unique characteristics of that element.
- Atomic number** The number of protons in a nucleus.
- Atomic weight** The number of protons and neutrons in the nucleus of an atom.
- Battery** An energy source that uses a chemical reaction to convert chemical energy into electrical energy.
- Charge** An electrical property of matter that exists because of an excess or a deficiency of electrons. Charge can be either positive or negative.
- Circuit** An interconnection of electrical components designed to produce a desired result. A basic circuit consists of a source, a load, and an interconnecting current path.
- Circuit breaker** A resettable protective device used for interrupting excessive current in an electric circuit.
- Circular mil (CM)** The unit of the cross-sectional area of a wire.
- Closed circuit** A circuit with a complete current path.
- Conductance** The ability of a circuit to allow current. The unit is the siemens (S).
- Conductor** A material in which electric current is easily established. An example is copper.
- Coulomb (C)** The unit of electrical charge.
- Current** The rate of flow of charge (electrons).
- Electrical** Related to the use of electrical voltage and current to achieve desired results.
- Electron** The basic particle of electrical charge in matter. The electron possesses negative charge.

62 ■ VOLTAGE, CURRENT, AND RESISTANCE

Electronic Related to the movement and control of free electrons in semiconductors or vacuum devices.

Element One of the unique substances that make up the known universe. Each element is characterized by a unique atomic structure.

Free electron A valence electron that has broken away from its parent atom and is free to move from atom to atom within the atomic structure of a material.

Fuse A protective device that burns open when there is excessive current in a circuit.

Generator An energy source that produces electrical signals.

Ground The common or reference point in a circuit.

Insulator A material that does not allow current under normal conditions.

Joule (J) The unit of energy.

Load The device in a circuit upon which work is done.

Multimeter An instrument that measures voltage, current, and resistance.

Neutron An atomic particle having no electrical charge.

Node A unique point in a circuit where two or more components are connected.

Ohm (Ω) The unit of resistance.

Ohmmeter An instrument for measuring resistance.

Open circuit A circuit in which there is not a complete current path.

Photoconductive cell A type of variable resistor that is light-sensitive.

Potentiometer A three-terminal variable resistor.

Power supply An electronic instrument that produces voltage, current, and power from the ac power line or batteries in a form suitable for use in powering electronic equipment.

Proton A positively charged atomic particle.

Resistance Opposition to current. The unit is the ohm (Ω).

Resistor An electrical component designed specifically to provide resistance.

Rheostat A two-terminal variable resistor.

Schematic A symbolized diagram of an electrical or electronic circuit.

Semiconductor A material that has a conductance value between that of a conductor and an insulator. Silicon and germanium are examples.

Shell The orbit in which an electron revolves.

Source A device that produces electrical energy.

Switch An electrical device for opening and closing a current path.

Tapered Nonlinear, such as a tapered potentiometer.

Thermistor A type of variable resistor.

Tolerance The limits of variation in the value of a component.

Valence Related to the outer shell or orbit of an atom.

Valence electron An electron that is present in the outermost shell of an atom.

Volt The unit of voltage or electromotive force.

Voltage The amount of energy available to move a certain number of electrons from one point to another in an electric circuit.

Voltmeter An instrument used to measure voltage.

Wiper The sliding contact in a potentiometer.

 ■ FORMULAS

(2-1)	$Q = \frac{\text{number of electrons}}{6.25 \times 10^{18} \text{ electrons/C}}$	Charge
(2-2)	$V = \frac{W}{Q}$	Voltage equals energy divided by charge.
(2-3)	$I = \frac{Q}{t}$	Current equals charge divided by time.

72 ■ OHM'S LAW

3-1 ■ OHM'S LAW

Ohm's law describes mathematically how voltage, current, and resistance in a circuit are related. Ohm's law is used in three equivalent forms depending on which quantity you need to determine. In this section, you will learn each of these forms.

After completing this section, you should be able to

■ Explain Ohm's law

- Describe how V , I , and R are related
- Express I as a function of V and R
- Express V as a function of I and R
- Express R as a function of V and I

Ohm determined experimentally that if the voltage across a resistor is increased, the current through the resistor will also increase; and, likewise, if the voltage is decreased, the current will decrease. For example, if the voltage is doubled, the current will double. If the voltage is halved, the current will also be halved. This relationship is illustrated in Figure 3-1, with relative meter indications of voltage and current.

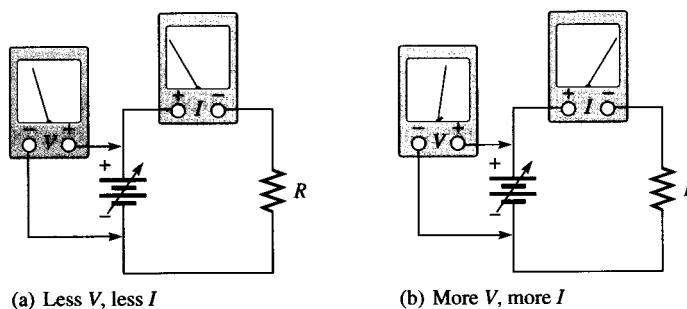

FIGURE 3-1
Effect of changing the voltage with the resistance at a constant value.

Ohm's law also states that if the voltage is kept constant, less resistance results in more current, and, also, more resistance results in less current. For example, if the resistance is halved, the current doubles. If the resistance is doubled, the current is halved. This concept is illustrated by the meter indications in Figure 3-2, where the resistance is increased and the voltage is held constant.

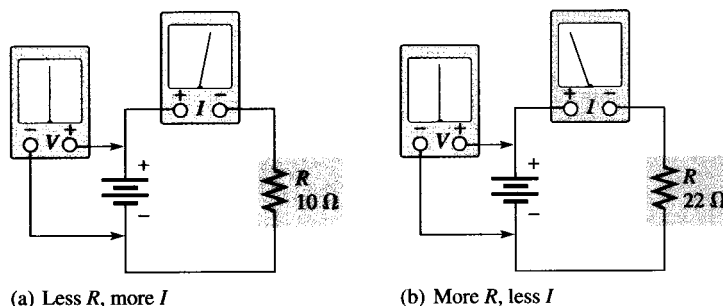

FIGURE 3-2
Effect of changing the resistance with the voltage at a constant value.

Formula for Current

Ohm's law can be stated as follows:

$$I = \frac{V}{R} \quad (3-1)$$

This formula describes what was indicated by the circuits of Figures 3-1 and 3-2. For a constant value of R , if the value of V is increased, the value of I increases; if V is decreased, I decreases. Also notice in Equation (3-1) that if V is constant and R is increased, I decreases. Similarly, if V is constant and R is decreased, I increases.

Using Equation (3-1), you can calculate the current if the values of voltage and resistance are known.

Formula for Voltage

Ohm's law can also be stated another way. By multiplying both sides of Equation (3-1) by R and transposing terms, you obtain an equivalent form of Ohm's law, as follows:

$$V = IR \quad (3-2)$$

With this equation, you can calculate voltage if the current and resistance are known.

Formula for Resistance

There is a third equivalent way to state Ohm's law. By dividing both sides of Equation (3-2) by I and transposing terms, you obtain

$$R = \frac{V}{I} \quad (3-3)$$

This form of Ohm's law is used to determine resistance if voltage and current values are known.

Remember, the three formulas—Equations (3-1), (3-2) and (3-3)—are all equivalent. They are simply three different ways of expressing Ohm's law.

**SECTION 3-1
REVIEW**

1. Ohm's law defines how three basic quantities are related. What are these quantities?
2. Write the Ohm's law formula for current.
3. Write the Ohm's law formula for voltage.
4. Write the Ohm's law formula for resistance.
5. If the voltage across a fixed-value resistor is tripled, does the current increase or decrease, and by how much?
6. If the voltage across a fixed resistor is cut in half, how much will the current change?
7. There is a fixed voltage across a resistor, and you measure a current of 1 A. If you replace the resistor with one that has twice the resistance value, how much current will you measure?
8. In a circuit the voltage is doubled and the resistance is cut in half. Would the current increase or decrease, and if so, by how much?

4-1 ■ ENERGY AND POWER

When there is current through a resistance, energy is released in the form of heat. A common example of this is a light bulb that becomes too hot to touch. The current through the filament that produces light also produces unwanted heat because the filament has resistance. Power is a measure of how fast energy is being used; electrical components must be able to dissipate a certain amount of energy in a given period of time.

After completing this section, you should be able to

- Define energy and power
 - Express power in terms of energy
 - State the unit of power
 - State the common units of energy
 - Perform energy and power calculations

Energy is the fundamental ability to do work.

Power is the rate at which energy is used.

In other words, **power**, symbolized by P , is a certain amount of **energy** used in a certain length of time, expressed as follows:

$$\text{Power} = \frac{\text{energy}}{\text{time}}$$

$$P = \frac{W}{t} \quad (4-1)$$

Energy is measured in **joules** (J), time is measured in seconds (s), and power is measured in **watts** (W). Note that an italic W is used to represent energy in the form of work and a nonitalic W is used for watts, the unit of power.

Energy in joules divided by time in seconds gives power in watts. For example, if 50 J of energy are used in 2 s, the power is $50 \text{ J} / 2 \text{ s} = 25 \text{ W}$. By definition,

One watt is the amount of power when one joule of energy is used in one second.

Thus, the number of joules used in one second is always equal to the number of watts. For example, if 75 J are used in 1 s, the power is 75 W.

EXAMPLE 4-1

An amount of energy equal to 100 J is used in 5 s. What is the power in watts?

Solution

$$P = \frac{\text{energy}}{\text{time}} = \frac{W}{t} = \frac{100 \text{ J}}{5 \text{ s}} = 20 \text{ W}$$

Related Exercise If 100 W of power occurs for 30 s, how much energy, in joules, is used?

Amounts of power much less than one watt are common in certain areas of electronics. As with small current and voltage values, metric prefixes are used to designate small amounts of power. Thus, milliwatts (mW), microwatts (μW), and even picowatts (pW) are commonly found in some applications.

104 ■ ENERGY AND POWER

The rating of the resistor is 1 W, which is insufficient to handle the power. The resistor has been overheated and may be burned out, making it an open.

Related Exercise A 0.25 W, 1 k Ω resistor is connected across a 12 V battery. Will it burn out?

SECTION 4-3
REVIEW

1. Name two important values associated with a resistor.
2. How does the physical size of a resistor determine the amount of power that it can handle?
3. List the standard power ratings of carbon-composition resistors.
4. A resistor must handle 0.3 W. What minimum power rating of a carbon resistor should be used to dissipate the energy properly?

4-4 ■ ENERGY CONVERSION AND VOLTAGE DROP IN RESISTANCE

As you have seen, when there is current through a resistance, electrical energy is converted to heat energy. This heat is caused by collisions of the free electrons within the atomic structure of the resistive material. When a collision occurs, heat is given off; and the electron loses some of its acquired energy.

After completing this section, you should be able to

- Explain energy conversion and voltage drop
 - Discuss the cause of energy conversion in a circuit
 - Define *voltage drop*
 - Explain the relationship between energy conversion and voltage drop

In Figure 4-10, electrons are flowing out of the negative terminal of the battery. They have acquired energy from the battery and are at their highest energy level at the negative side of the circuit. As the electrons move through the resistor, they lose energy. The electrons emerging from the upper end of the resistor are at a lower energy level than those entering the lower end because some of the energy they had has been converted to heat. The drop in energy level of the electrons as they move through the resistor creates a potential difference, or **voltage drop**, across the resistor having the polarity shown in Figure 4-10. Notice that the upper end of the resistor in Figure 4-10 is less negative (more positive) than the lower end.

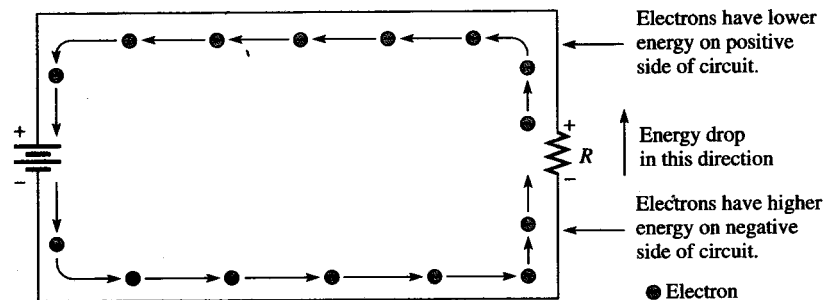

FIGURE 4-10
Electron flow in a simple circuit.

110 ■ ENERGY AND POWER

**SECTION 4-7
REVIEW**

1. Explain each of the following .DC control statements:
 - (a) .DC V1 1 8 1
 - (b) .DC I1 1M 5M 2.5M
2. Explain each of the following .PRINT statements:
 - (a) .PRINT DC V(R2) V(R3)
 - (b) .PRINT DC I(R1) I(R2) I(R3)

■ SUMMARY

- One watt equals one joule per second.
- Watt is the unit of power, joule is a unit of energy, and second is a unit of time.
- The power rating of a resistor determines the maximum power that it can handle safely.
- Resistors with a larger physical size can dissipate more power in the form of heat than smaller ones.
- A resistor should have a power rating higher than the maximum power that it is expected to handle in the circuit.
- Power rating is not related to resistance value.
- A resistor normally opens when it burns out.
- Energy is equal to power multiplied by time.
- The kilowatt-hour is a unit of energy.
- One kilowatt-hour is one thousand watts used for one hour.
- A power supply is an energy source used to operate electrical and electronic devices.
- A battery is one type of power supply that converts chemical energy into electrical energy.
- An electronic power supply converts commercial energy (ac from the power company) to regulated dc or ac at various voltage levels.
- The output power of a supply is the output voltage times the load current.
- A load is a device that draws current from the power supply.
- The capacity of a battery is measured in ampere-hours (Ah).
- One ampere-hour equals one ampere used for one hour, or any other combination of amperes and hours that has a product of one.
- A power supply with a high efficiency wastes less power than one with a lower efficiency.

■ GLOSSARY

Ampere-hour rating A number given in ampere-hours (Ah) determined by multiplying the current (A) times the length of time (h) a battery can deliver that current to a load.

Efficiency The ratio of the output power to the input power of a circuit, expressed as a percent.

Energy The fundamental ability to do work.

Joule (J) The unit of energy.

Kilowatt-hour (kWh) A common unit of energy used mainly by utility companies.

Power The rate of energy usage.

Power rating The maximum amount of power that a resistor can dissipate without being damaged by excessive heat buildup.

Voltage drop The drop in energy level through a resistor.

Watt (W) The unit of power. One watt is the power when 1 J of energy is used in 1 s.

Watt's law A law that states the relationships of power to current, voltage, and resistance.

■ FORMULAS

- | | | |
|-------|-------------------|--|
| (4-1) | $P = \frac{W}{t}$ | Power equals energy divided by time. |
| (4-2) | $W = Pt$ | Energy equals power multiplied by time. |
| (4-3) | $P = I^2R$ | Power equals current squared times resistance. |

- (4-4) $P = VI$ Power equals voltage times current.
- (4-5) $P = \frac{V^2}{R}$ Power equals voltage squared divided by resistance.
- (4-6) Efficiency = $\frac{P_{OUT}}{P_{IN}}$ Power supply efficiency
- (4-7) $P_{OUT} = P_{IN} - P_{LOSS}$ Output power is input power less power loss.

■ SELF-TEST

1. Power can be defined as
 - (a) energy
 - (b) heat
 - (c) the rate at which energy is used
 - (d) the time required to use energy
2. Two hundred joules of energy are consumed in 10 s. The power is
 - (a) 2000 W
 - (b) 10 W
 - (c) 20 W
 - (d) 2 W
3. If it takes 300 ms to use 10,000 J of energy, the power is
 - (a) 33.3 kW
 - (b) 33.3 W
 - (c) 33.3 mW
4. In 50 kW, there are
 - (a) 500 W
 - (b) 5000 W
 - (c) 0.5 MW
 - (d) 50,000 W
5. In 0.045 W, there are
 - (a) 45 kW
 - (b) 45 mW
 - (c) 4,500 μ W
 - (d) 0.00045 MW
6. For 10 V and 50 mA, the power is
 - (a) 500 mW
 - (b) 0.5 W
 - (c) 500,000 μ W
 - (d) answers (a), (b), and (c)
7. When the current through a 10 k Ω resistor is 10 mA, the power is
 - (a) 1 W
 - (b) 10 W
 - (c) 100 mW
 - (d) 1000 μ W
8. A 2.2 k Ω resistor dissipates 0.5 W. The current is
 - (a) 15.1 mA
 - (b) 0.227 mA
 - (c) 1.1 mA
 - (d) 4.4 mA
9. A 330 Ω resistor dissipates 2 W. The voltage is
 - (a) 2.57 V
 - (b) 660 V
 - (c) 6.6 V
 - (d) 25.7 V
10. If you used 500 W of power for 24 h, you have used
 - (a) 0.5 kWh
 - (b) 2400 kWh
 - (c) 12,000 kWh
 - (d) 12 kWh
11. How many watt-hours represent 75 W used for 10 h?
 - (a) 75 Wh
 - (b) 750 Wh
 - (c) 0.75 Wh
 - (d) 7500 Wh
12. A 100 Ω resistor must carry a maximum current of 35 mA. Its rating should be at least
 - (a) 35 W
 - (b) 35 mW
 - (c) 123 mW
 - (d) 3500 mW
13. The power rating of a carbon-composition resistor that is to handle up to 1.1 W should be
 - (a) 0.25 W
 - (b) 1 W
 - (c) 2 W
 - (d) 5 W
14. A 22 Ω half-watt resistor and a 220 Ω half-watt resistor are connected across a 10 V source. Which one(s) will overheat?
 - (a) 22 Ω
 - (b) 220 Ω
 - (c) both
 - (d) neither
15. When the needle of an analog ohmmeter indicates infinity, the resistor being measured is
 - (a) overheated
 - (b) shorted
 - (c) open
 - (d) reversed
16. A 12 V battery is connected to a 600 Ω load. Under these conditions, it is rated at 50 Ah. How long can it supply current to the load?
 - (a) 2500 h
 - (b) 50 h
 - (c) 25 h
 - (d) 4.16 h
17. A given power supply is capable of providing 8 A for 2.5 h. Its ampere-hour rating is
 - (a) 2.5 Ah
 - (b) 20 Ah
 - (c) 8 Ah
18. A power supply produces a 0.5 W output with an input of 0.6 W. Its percentage of efficiency is
 - (a) 50%
 - (b) 60%
 - (c) 83.3%
 - (d) 45%

262 ■ SERIES-PARALLEL CIRCUITS

- The load resistor should be large compared to the resistance across which it is connected, in order that the loading effect may be minimized. A *10-times* value is sometimes used as a rule of thumb, but the value depends on the accuracy required for the output voltage.
- To find total resistance of a ladder network, start at the point farthest from the source and reduce the resistance in steps.
- A Wheatstone bridge can be used to measure an unknown resistance.
- A bridge is balanced when the output voltage is zero. The balanced condition produces zero current through a load connected across the output terminals of the bridge.
- Open circuits and short circuits are typical circuit faults.
- Resistors normally open when they burn out.

■ GLOSSARY

Bleeder current The current left after the total load current is subtracted from the total current into the circuit.

Load An element (resistor or other component) connected across the output terminals of a circuit that draws current from the circuit.

Sensitivity factor The ohms-per-volt rating of a voltmeter.

■ FORMULA

$$(7-1) \quad R_{\text{UNK}} = R_V \left(\frac{R_2}{R_4} \right) \quad \text{Unknown resistance in a Wheatstone bridge}$$

■ SELF-TEST

1. Which of the following statements are true concerning Figure 7-63?
 - (a) R_1 and R_2 are in series with R_3 , R_4 , and R_5
 - (b) R_1 and R_2 are in series
 - (c) R_3 , R_4 , and R_5 are in parallel
 - (d) The series combination of R_1 and R_2 is in parallel with the series combination of R_3 , R_4 , and R_5
 - (e) answers (b) and (d)

FIGURE 7-63

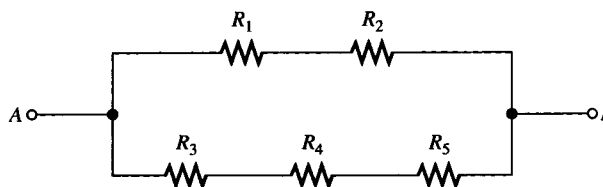

2. The total resistance of Figure 7-63 can be found with which of the following formulas?
 - (a) $R_1 + R_2 + R_3 \parallel R_4 \parallel R_5$
 - (b) $R_1 \parallel R_2 + R_3 \parallel R_4 \parallel R_5$
 - (c) $(R_1 + R_2) \parallel (R_3 + R_4 + R_5)$
 - (d) none of these answers
3. If all of the resistors in Figure 7-63 have the same value, when voltage is applied across terminals A and B, the current is
 - (a) greatest in R_5
 - (b) greatest in R_3 , R_4 , and R_5
 - (c) greatest in R_1 and R_2
 - (d) the same in all the resistors
4. Two $1 \text{ k}\Omega$ resistors are in series and this series combination is in parallel with a $2.2 \text{ k}\Omega$ resistor. The voltage across one of the $1 \text{ k}\Omega$ resistors is 6 V . The voltage across the $2.2 \text{ k}\Omega$ resistor is
 - (a) 6 V
 - (b) 3 V
 - (c) 12 V
 - (d) 13.2 V
5. The parallel combination of a 330Ω resistor and a 470Ω resistor is in series with the parallel combination of four $1 \text{ k}\Omega$ resistors. A 100 V source is connected across the circuit. The resistor with the most current has a value of
 - (a) $1 \text{ k}\Omega$
 - (b) 330Ω
 - (c) 470Ω

8-1 ■ THE VOLTAGE SOURCE

The voltage source is the principal type of energy source in electronic applications, so it is important to understand its characteristics. The voltage source ideally provides constant voltage to a load even when the load resistance varies.

After completing this section, you should be able to

- Describe the characteristics of a voltage source
 - Compare a practical voltage source to an ideal source
 - Discuss the effect of loading on a practical voltage source

Figure 8-1(a) is the familiar symbol for an ideal dc **voltage source**. The voltage across its terminals *A* and *B* remains fixed regardless of the value of load resistance that may be connected across its output. Figure 8-1(b) shows a load resistor, R_L , connected. All of the source voltage, V_S , is dropped across R_L . Ideally, R_L can be changed to any value except zero, and the voltage will remain fixed. The ideal voltage source has an internal resistance of zero.

FIGURE 8-1
Ideal dc voltage source.

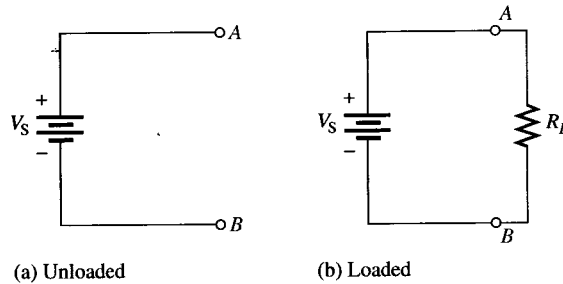

In reality, no voltage source is ideal. That is, all voltage sources have some inherent internal resistance as a result of their physical and/or chemical makeup, which can be represented by a resistor in series with an ideal source, as shown in Figure 8-2(a). R_S is the internal source resistance and V_S is the source voltage. With no load, the output voltage (voltage from *A* to *B*) is V_S . This voltage is sometimes called the *open circuit voltage*.

FIGURE 8-2
Practical voltage source.

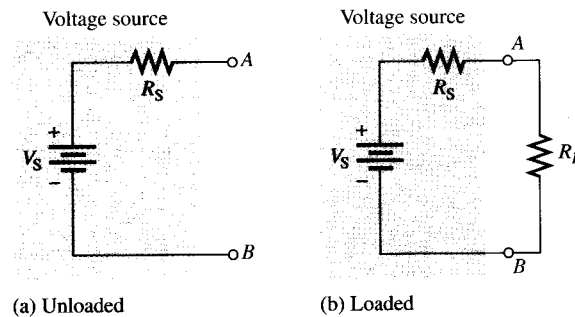

Loading of the Voltage Source

When a load resistor is connected across the output terminals, as shown in Figure 8-2(b), all of the source voltage does not appear across R_L . Some of the voltage is dropped across R_S because R_S and R_L are in series.

If R_S is very small compared to R_L , the source approaches ideal because almost all of the source voltage, V_S , appears across the larger resistance, R_L . Very little voltage is

dropped across the internal resistance, R_S . If R_L changes, most of the source voltage remains across the output as long as R_L is much larger than R_S . As a result, very little change occurs in the output voltage. The larger R_L is compared to R_S , the less change there is in the output voltage. As a rule, before it can be neglected, R_L should be at least ten times R_S ($R_L \geq 10R_S$).

Example 8–1 illustrates the effect of changes in R_L on the output voltage when R_L is much greater than R_S . Example 8–2 shows the effect of smaller load resistances.

EXAMPLE 8–1

Calculate the voltage output of the source in Figure 8–3 for the following values of R_L : 100 Ω , 560 Ω , and 1 k Ω .

FIGURE 8–3

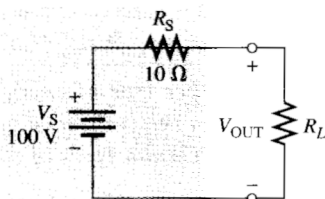

Solution For $R_L = 100 \Omega$, the voltage output is

$$V_{\text{OUT}} = \left(\frac{R_L}{R_S + R_L} \right) V_S = \left(\frac{100 \Omega}{110 \Omega} \right) 100 \text{ V} = 90.9 \text{ V}$$

For $R_L = 560 \Omega$,

$$V_{\text{OUT}} = \left(\frac{560 \Omega}{570 \Omega} \right) 100 \text{ V} = 98.2 \text{ V}$$

For $R_L = 1 \text{ k}\Omega$,

$$V_{\text{OUT}} = \left(\frac{1000 \Omega}{1010 \Omega} \right) 100 \text{ V} = 99.0 \text{ V}$$

Notice that the output voltage is within 10% of the source voltage, V_S , for all three values of R_L , because R_L is at least ten times R_S .

Related Exercise Determine V_{OUT} in Figure 8–3 if $R_S = 50 \Omega$ and $R_L = 10 \text{ k}\Omega$.

EXAMPLE 8–2

Determine V_{OUT} for $R_L = 10 \Omega$ and for $R_L = 1 \Omega$ in Figure 8–3.

Solution For $R_L = 10 \Omega$, the voltage output is

$$V_{\text{OUT}} = \left(\frac{R_L}{R_S + R_L} \right) V_S = \left(\frac{10 \Omega}{20 \Omega} \right) 100 \text{ V} = 50 \text{ V}$$

For $R_L = 1 \Omega$,

$$V_{\text{OUT}} = \left(\frac{1 \Omega}{11 \Omega} \right) 100 \text{ V} = 9.09 \text{ V}$$

Related Exercise What is V_{OUT} with no load resistor in Figure 8–3?

**SECTION 8-7
REVIEW**

1. To what type of circuit does Millman's theorem apply?
2. Write the Millman theorem formula for R_{EQ} .
3. Write the Millman theorem formula for V_{EQ} .
4. Find the load current (I_L) and the load voltage (V_L) in Figure 8-54.

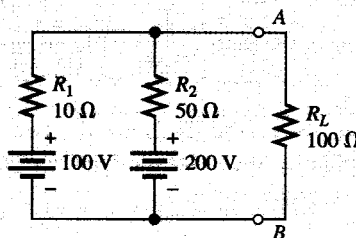
FIGURE 8-54**8-8 ■ MAXIMUM POWER TRANSFER THEOREM**

The maximum power transfer theorem is important when you need to know the value of the load at which the most power is delivered from the source.

After completing this section, you should be able to

- Apply the maximum power transfer theorem
 - State the theorem
 - Determine the value of load resistance for which maximum power is transferred from a given circuit

The **maximum power transfer** theorem states as follows:

When a source is connected to a load, maximum power is delivered to the load when the load resistance is equal to the internal source resistance.

The source resistance, R_S , of a circuit is the equivalent resistance as viewed from the output terminals using Thevenin's theorem. An equivalent circuit with its output resistance and load is shown in Figure 8-55. When $R_L = R_S$, the maximum power possible is transferred from the voltage source to R_L .

FIGURE 8-55

Maximum power is transferred to the load when $R_L = R_S$.

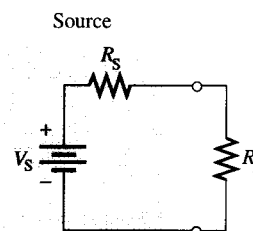

Practical applications of this theorem include audio systems such as stereo, radio, and public address. In these systems the resistance of the speaker is the load. The circuit that drives the speaker is a power amplifier. The systems are typically optimized for maximum power to the speakers. Thus, the resistance of the speaker must equal the internal source resistance of the amplifier.

Example 8-16 shows that maximum power occurs when $R_L = R_S$.

11-1 ■ THE SINE WAVE

The sine wave is a common type of alternating current (ac) and alternating voltage. It is also referred to as a sinusoidal wave or, simply, sinusoid. The electrical service provided by the power company is in the form of sinusoidal voltage and current. In addition, other types of waveforms are composites of many individual sine waves called harmonics.

After completing this section, you should be able to

- Identify a sinusoidal waveform and measure its characteristics
 - Determine the period
 - Determine the frequency
 - Relate the period and the frequency

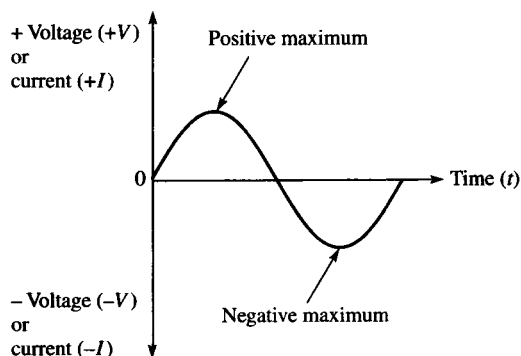

FIGURE 11-1
Symbol for a sine wave voltage source.

Sine waves are produced by two types of sources: rotating electrical machines (ac generators) or electronic oscillator circuits, which are in instruments known as electronic signal generators. Figure 11-1 shows the symbol used to represent either source of sine wave voltage.

Figure 11-2 is a graph showing the general shape of a sine wave, which can be either an **alternating current** or voltage. Voltage (or current) is displayed on the vertical axis and time (t) is displayed on the horizontal axis. Notice how the voltage (or current) varies with time. Starting at zero, the voltage (or current) increases to a positive maximum (peak), returns to zero, and then increases to a negative maximum (peak) before returning again to zero, thus completing one full cycle.

FIGURE 11-2
Graph of one cycle of a sine wave.



Polarity of a Sine Wave

As you have learned, a sine wave changes polarity at its zero value; that is, it alternates between positive and negative values. When a sine wave voltage source (V_s) is applied to a resistive circuit, as in Figure 11-3, an alternating sine wave current results. When the voltage changes polarity, the current correspondingly changes direction as indicated.

During the positive alternation of the applied voltage V_s , the current is in the direction shown in Figure 11-3(a). During a negative alternation of the applied voltage, the current is in the opposite direction, as shown in Figure 11-3(b). The combined positive and negative alternations make up one **cycle** of a sine wave.

FIGURE 11-3
Alternating current and voltage.

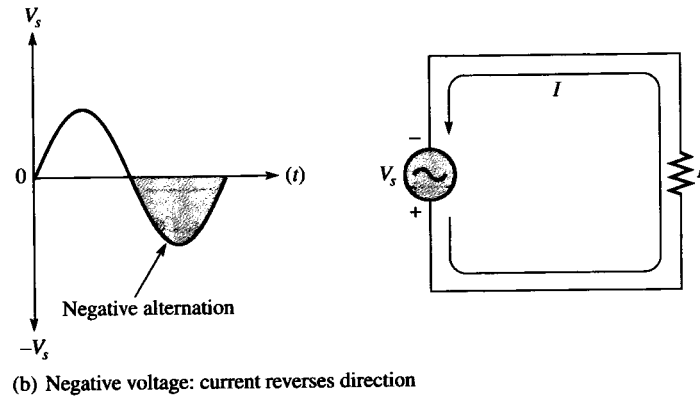
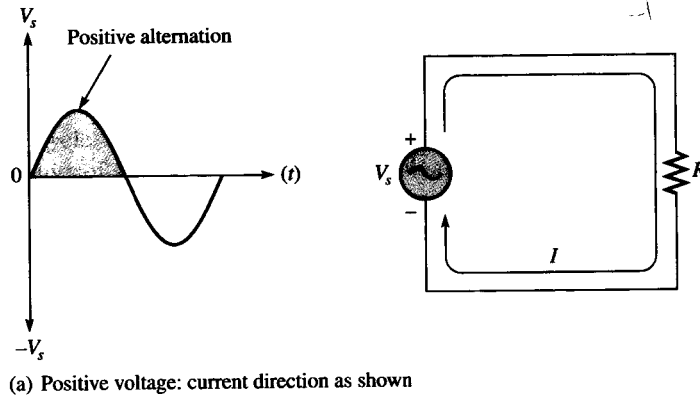

Period of a Sine Wave

A sine wave varies with time (t) in a definable manner.

The time required for a sine wave to complete one full cycle is called the period (T).

Figure 11-4(a) illustrates the **period** of a sine wave. Typically, a sine wave continues to repeat itself in identical cycles, as shown in Figure 11-4(b). Since all cycles of a repetitive sine wave are the same, the period is always a fixed value for a given sine wave. The period of a sine wave does not necessarily have to be measured between the zero crossings at the beginning and end of a cycle. It can be measured from any peak in a given cycle to the corresponding peak in the next cycle.

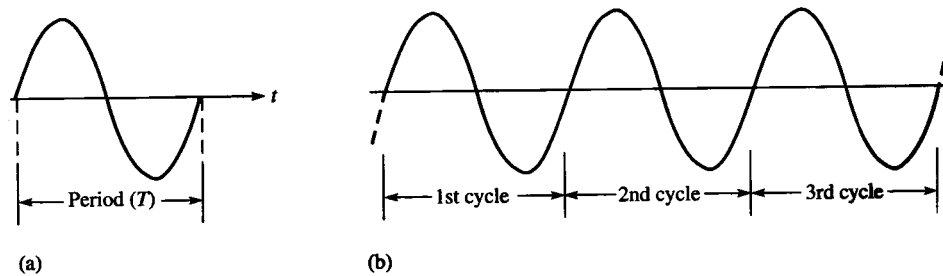

FIGURE 11-4
The period of a sine wave is the same for each cycle.

Frequency of a Sine Wave

Frequency is the number of cycles that a sine wave completes in one second.

The more cycles completed in one second, the higher the frequency. **Frequency (f)** is measured in units of **hertz, Hz**. One hertz is equivalent to one cycle per second; 60 Hz is 60 cycles per second; and so on. Figure 11–8 shows two sine waves. The sine wave in part (a) completes two full cycles in one second. The one in part (b) completes four cycles in one second. Therefore, the sine wave in part (b) has twice the frequency of the one in part (a).

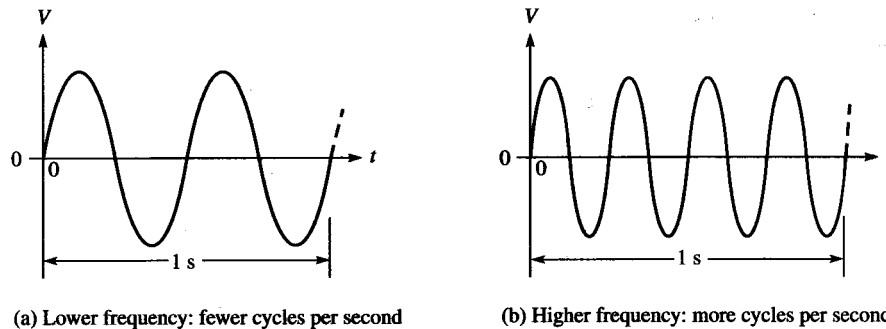

FIGURE 11–8
Illustration of frequency.

Relationship of Frequency and Period

The formulas for the relationship between frequency (f) and period (T) are as follows:

$$f = \frac{1}{T} \quad (11-1)$$

$$T = \frac{1}{f} \quad (11-2)$$

There is a reciprocal relationship between f and T . Knowing one, you can calculate the other with the $\frac{1}{x}$ key on your calculator. This inverse relationship makes sense because a sine wave with a longer period goes through fewer cycles in one second than one with a shorter period.

EXAMPLE 11–3

Which sine wave in Figure 11–9 has a higher frequency? Determine the period and the frequency of both waveforms.

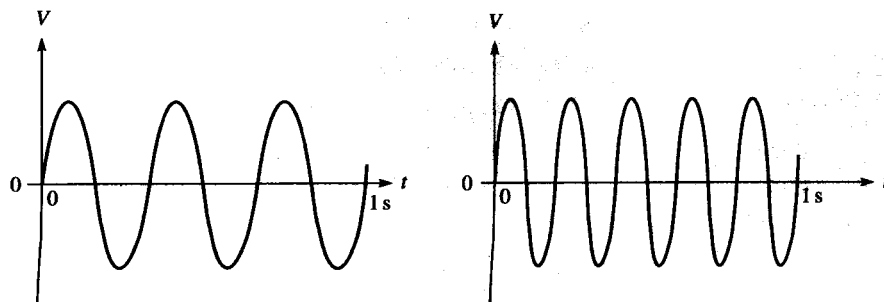

FIGURE 11–9

Average Value

The average value of a sine wave taken over one complete cycle is always zero, because the positive values (above the zero crossing) offset the negative values (below the zero crossing).

To be useful for comparison purposes, the average value of a sine wave is defined over a half-cycle rather than over a full cycle. The **average value** is the total area under the half-cycle curve divided by the distance in radians of the curve along the horizontal axis. The result is derived in Appendix C and is expressed in terms of the peak value as follows for both voltage and current sine waves:

$$V_{\text{avg}} = \left(\frac{2}{\pi}\right)V_p$$

$$V_{\text{avg}} = 0.637V_p \quad (11-12)$$

$$I_{\text{avg}} = \left(\frac{2}{\pi}\right)I_p$$

$$I_{\text{avg}} = 0.637I_p \quad (11-13)$$

EXAMPLE 11-7

Determine V_p , V_{pp} , V_{rms} , and the half-cycle V_{avg} for the sine wave in Figure 11-19.

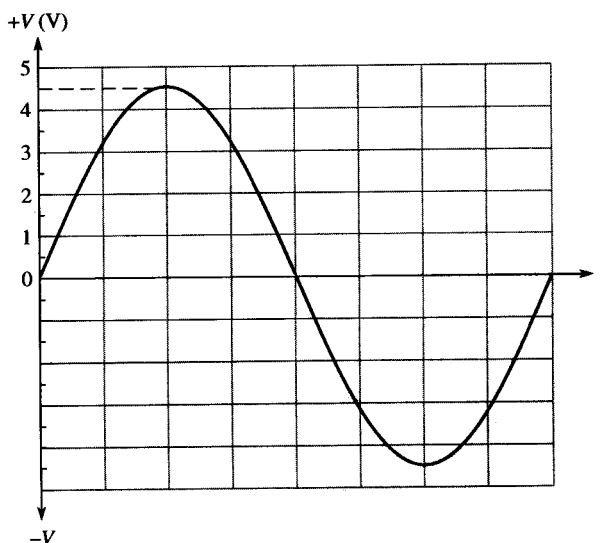

FIGURE 11-19

Solution $V_p = 4.5 \text{ V}$ is taken directly from the graph. From this, calculate the other values.

$$V_{pp} = 2V_p = 2(4.5 \text{ V}) = 9 \text{ V}$$

$$V_{\text{rms}} = 0.707V_p = 0.707(4.5 \text{ V}) = 3.18 \text{ V}$$

$$V_{\text{avg}} = 0.637V_p = 0.637(4.5 \text{ V}) = 2.87 \text{ V}$$

Related Exercise If $V_p = 25 \text{ V}$, determine V_{pp} , V_{rms} , and V_{avg} for a sine wave.

**SECTION 11-4
REVIEW**

- When the positive-going zero crossing of a sine-wave occurs at 0° , at what angle does each of the following points occur?
 - Positive peak
 - Negative-going zero crossing
 - Negative peak
 - End of first complete cycle
- A half-cycle is completed in _____ degrees or _____ radians.
- A full cycle is completed in _____ degrees or _____ radians.
- Determine the phase angle between the two sine waves in Figure 11-27.

FIGURE 11-27

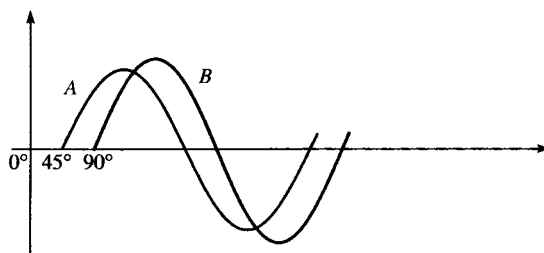
**11-5 ■ THE SINE WAVE FORMULA**

A sine wave can be graphically represented by voltage or current values on the vertical axis and by angular measurement (degrees or radians) along the horizontal axis. This graph can be expressed mathematically, as you will see.

After completing this section, you should be able to

- Mathematically analyze a sinusoidal waveform
 - State the sine wave formula
 - Find instantaneous values using the formula

A generalized graph of one cycle of a sine wave is shown in Figure 11-28. The **amplitude**, A , is the maximum value of the voltage or current on the vertical axis, and angular values run along the horizontal axis. The variable y is an instantaneous value representing either voltage or current at a given angle, θ .

FIGURE 11-28

One cycle of a generalized sine wave showing amplitude and phase.

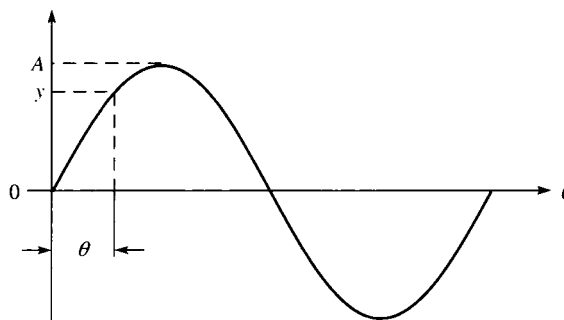

A sine wave curve follows a specific mathematical formula. The general expression for the sine wave curve in Figure 11-28 is

$$y = A \sin \theta \quad (11-16)$$

How a Capacitor Stores Energy

A capacitor stores energy in the form of an electric field that is established by the opposite charges on the two plates. The electric field is represented by lines of force between the positive and negative charges and concentrated within the dielectric, as shown in Figure 13–3.

FIGURE 13–3
The electric field stores energy in a capacitor.

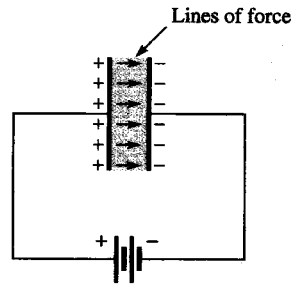

Coulomb's law states

A force exists between two charged bodies that is directly proportional to the product of the two charges and inversely proportional to the square of the distance between the bodies.

This relationship is expressed as

$$F = \frac{kQ_1Q_2}{d^2} \quad (13-4)$$

where F is the force in newtons, Q_1 and Q_2 are the charges in coulombs, d is the distance between the charges in meters, and k is a proportionality constant equal to 9×10^9 .

Figure 13–4(a) illustrates the line of force between a positive and a negative charge. Figure 13–4(b) shows that many opposite charges on the plates of a capacitor create many lines of force, which form an electric field that stores energy within the dielectric.

FIGURE 13–4
Lines of force are created by opposite charges.

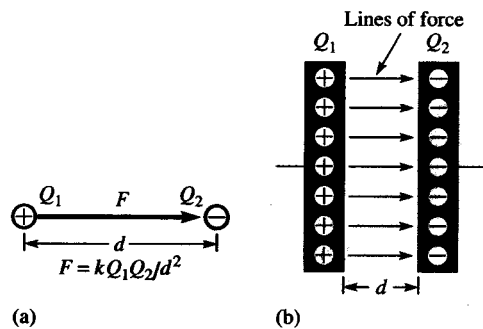

The greater the forces between the charges on the plates of a capacitor, the more energy is stored. The amount of energy stored therefore is directly proportional to the capacitance because, from Coulomb's law, the more charge stored, the greater the force.

Also, from Equation (13–2), the amount of charge stored is directly related to the voltage as well as the capacitance. Therefore, the amount of energy stored is also dependent on the square of the voltage across the plates of the capacitor. The formula for the energy stored by a capacitor is as follows:

$$W = \frac{1}{2}CV^2 \quad (13-5)$$

When capacitance (C) is in farads and voltage (V) is in volts, the energy (W) is in joules.

EXAMPLE 13–10 Determine C_T in Figure 13–27.

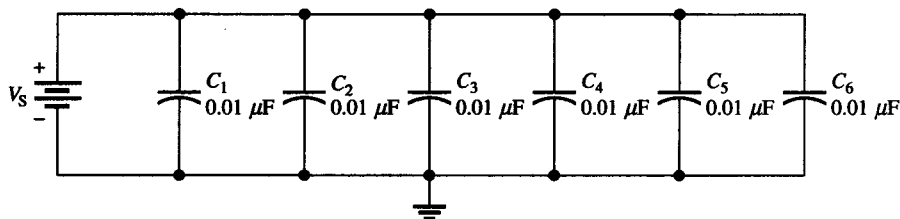

FIGURE 13–27

Solution There are six equal-value capacitors in parallel, so $n = 6$.

$$C_T = nC = (6)(0.01 \mu\text{F}) = 0.06 \mu\text{F}$$

Related Exercise If three more $0.01 \mu\text{F}$ capacitors are connected in parallel in Figure 13–27, what is the total capacitance?

SECTION 13–4 REVIEW

1. How is total parallel capacitance determined?
2. In a certain application, you need $0.05 \mu\text{F}$. The only values available are $0.01 \mu\text{F}$, which are available in large quantities. How can you get the total capacitance that you need?
3. The following capacitors are in parallel: 10 pF , 5 pF , 33 pF , and 50 pF . What is C_T ?

13–5 ■ CAPACITORS IN DC CIRCUITS

A capacitor will charge up when it is connected to a dc voltage source. The buildup of charge across the plates occurs in a predictable manner which is dependent on the capacitance and the resistance in a circuit.

After completing this section, you should be able to

- Analyze capacitive dc switching circuits
 - Describe the charging and discharging of a capacitor
 - Define *time constant*
 - Relate the time constant to charging and discharging
 - Write equations for the charging and discharging curves
 - Explain why a capacitor blocks dc

Charging a Capacitor

A capacitor charges when it is connected to a dc voltage source, as shown in Figure 13–28. The capacitor in part (a) of the figure is uncharged; that is, plate A and plate B have equal numbers of free electrons. When the switch is closed, as shown in part (b), the source moves electrons away from plate A through the circuit to plate B as the arrows indicate. As plate A loses electrons and plate B gains electrons, plate A becomes positive with respect to plate B. As this charging process continues, the voltage across the plates

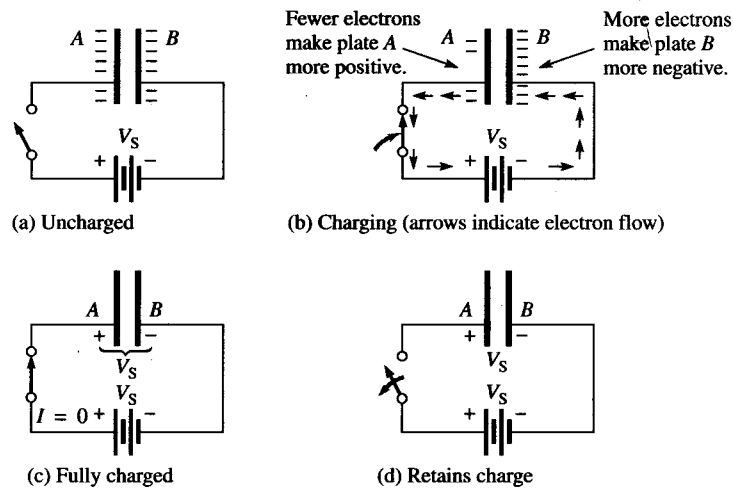

FIGURE 13–28
Charging a capacitor.

builds up rapidly until it is equal to the applied voltage, V_s , but opposite in polarity, as shown in part (c). When the capacitor is fully charged, there is no current.

A capacitor blocks constant dc.

When the charged capacitor is disconnected from the source, as shown in Figure 13–28(d), it remains charged for long periods of time, depending on its leakage resistance, and can cause severe electrical shock. The charge on an electrolytic capacitor generally leaks off more rapidly than in other types of capacitors.

Discharging a Capacitor

When a wire is connected across a charged capacitor, as shown in Figure 13–29, the capacitor will discharge. In this particular case, a very low resistance path (the wire) is connected across the capacitor with a switch. Before the switch is closed, the capacitor is charged to 50 V, as indicated in part (a). When the switch is closed, as shown in part (b), the excess electrons on plate B move through the circuit to plate A (indicated by the arrows); as a result of the current through the low resistance of the wire, the energy stored by the capacitor is dissipated in the wire. The charge is neutralized when the numbers of free electrons on both plates are again equal. At this time, the voltage across the capacitor is zero, and the capacitor is completely discharged, as shown in part (c).

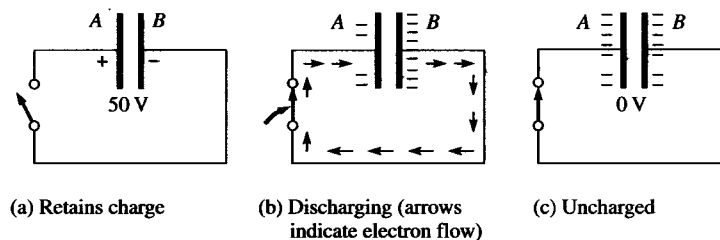

FIGURE 13–29
Discharging a capacitor.

Current and Voltage During Charging and Discharging

Notice in Figures 13–28 and 13–29 that the direction of the current during discharge is opposite to that of the charging current. It is important to understand that *there is no current through the dielectric of the capacitor during charging or discharging because the dielectric is an insulating material*. There is current from one plate to the other only through the external circuit.

Figure 13–30(a) shows a capacitor connected in series with a resistor and a switch to a dc voltage source. Initially, the switch is open and the capacitor is uncharged with zero volts across its plates. At the instant the switch is closed, the current jumps to its maximum value and the capacitor begins to charge. The current is maximum initially because the capacitor has zero volts across it and, therefore, effectively acts as a short; thus, the current is limited only by the resistance. As time passes and the capacitor charges, the current decreases and the voltage across the capacitor (V_C) increases. The resistor voltage is proportional to the current during this charging period.

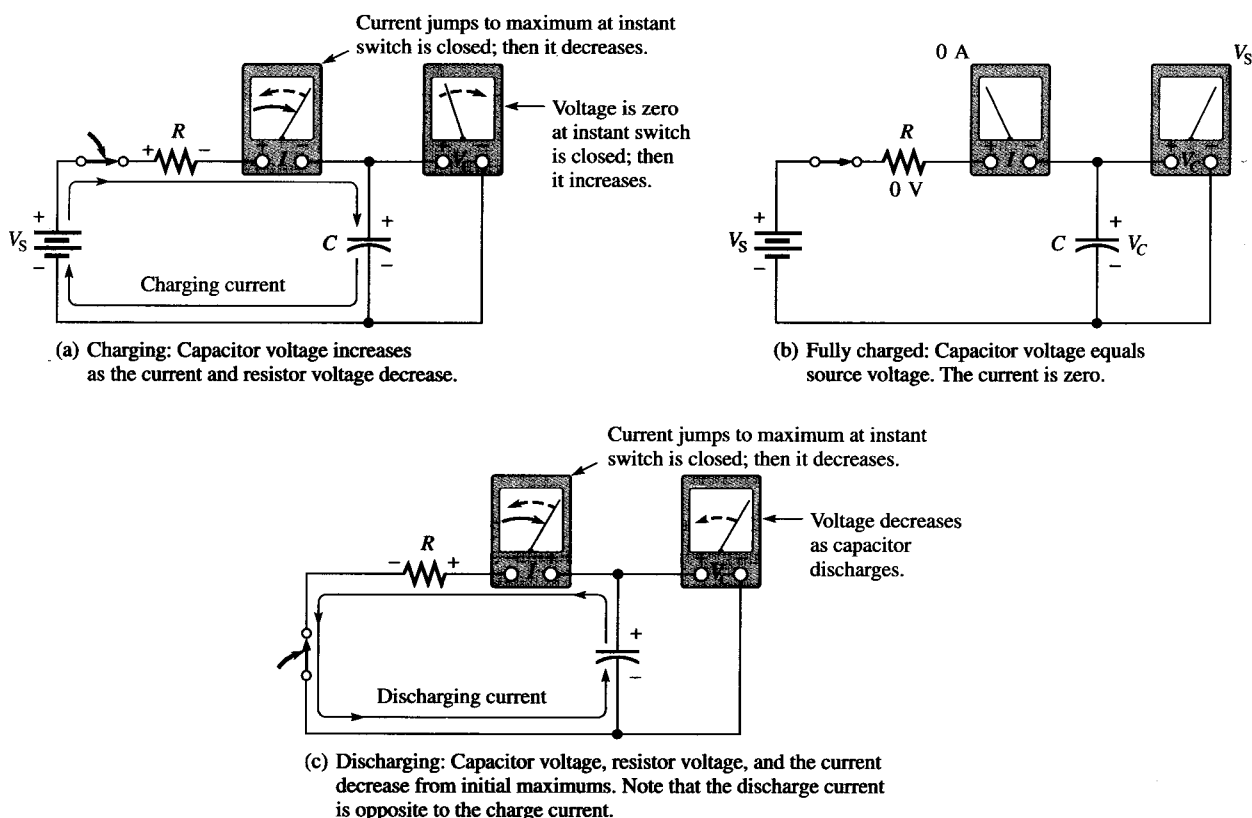

FIGURE 13–30

Current and voltage in a charging and discharging capacitor.

After a certain period of time, the capacitor reaches full charge. At this point, the current is zero and the capacitor voltage is equal to the dc source voltage, as shown in Figure 13–30(b). If the switch were opened now, the capacitor would retain its full charge (neglecting any leakage).

In Figure 13–30(c), the voltage source has been removed. When the switch is closed, the capacitor begins to discharge. Initially, the current jumps to a maximum but in a direction opposite to its direction during charging. As time passes, the current and capacitor voltage decrease. The resistor voltage is always proportional to the current. When the capacitor has fully discharged, the current and the capacitor voltage are zero.

Remember the following rules about capacitors in dc circuits:

1. Voltage across a capacitor *cannot* change instantaneously.
2. Current in a capacitive circuit *can* ideally change instantaneously.
3. A fully charged capacitor appears as an *open* to nonchanging current.
4. An uncharged capacitor appears as a *short* to an instantaneous change in current.

Now we will examine in more detail how the voltage and current change with time in a capacitive circuit.

The RC Time Constant

In a practical situation, there cannot be capacitance without some resistance in a circuit. It may simply be the small resistance of a wire, or it may be a designed-in resistance. Because of this, the charging and discharging characteristics of a capacitor must always be considered in light of the associated resistance. The resistance introduces the element of *time* in the charging and discharging of a capacitor.

When a capacitor charges or discharges through a resistance, a certain time is required for the capacitor to charge fully or discharge fully. The voltage across a capacitor cannot change instantaneously because a finite time is required to move charge from one point to another. The rate at which the capacitor charges or discharges is determined by the **time constant** of the circuit.

The time constant of a series RC circuit is a time interval that equals the product of the resistance and the capacitance.

The time constant is expressed in seconds when resistance is in ohms and capacitance is in farads. It is symbolized by τ (Greek letter tau), and the formula is as follows:

$$\tau = RC \quad (13-17)$$

Recall that $I = Q/t$. The current depends on the amount of charge moved in a given time. When the resistance is increased, the charging current is reduced, thus increasing the charging time of the capacitor. When the capacitance is increased, the amount of charge increases; thus, for the same current, more time is required to charge the capacitor.

EXAMPLE 13-11 A series RC circuit has a resistance of 1 M Ω and a capacitance of 5 μ F. What is the time constant?

Solution $\tau = RC = (1 \times 10^6 \Omega)(5 \times 10^{-6} \text{ F}) = 5 \text{ s}$

Related Exercise A series RC circuit has a 270 k Ω resistor and a 3300 pF capacitor. What is the time constant?

During one time-constant interval, the charge on a capacitor changes approximately 63%.

An uncharged capacitor charges to 63% of its fully charged voltage in one time constant. When a capacitor is discharging, its voltage drops to approximately 100% – 63% = 37% of its initial value in one time constant, which is a 63% change.

The Charging and Discharging Curves

A capacitor charges and discharges following a nonlinear curve, as shown in Figure 13–31. In these graphs, the approximate percentage of full charge is shown at each time-constant interval. This type of curve follows a precise mathematical formula and is called an *exponential curve*. The charging curve is an increasing exponential, and the discharging curve is a decreasing exponential. It takes five time constants to approximately reach the final value. A five time-constant interval is accepted as the time to fully charge or discharge a capacitor and is called the *transient time*.

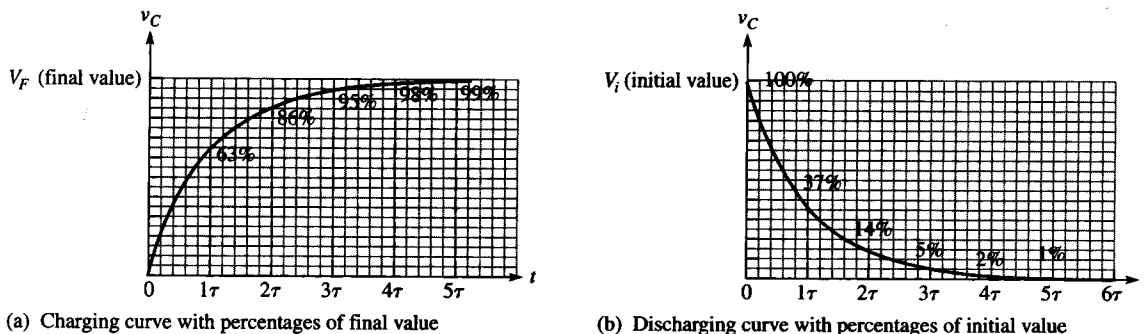

FIGURE 13–31
Charging and discharging exponential curves for an RC circuit.

General Formula The general expressions for either increasing or decreasing exponential curves are given in the following equations for both instantaneous voltage and instantaneous current.

$$v = V_F + (V_i - V_F)e^{-t/\tau} \quad (13-18)$$

$$i = I_F + (I_i - I_F)e^{-t/\tau} \quad (13-19)$$

where V_F and I_F are the final values, and V_i and I_i are the initial values. v and i are the instantaneous values of the capacitor voltage or current at time t , and e is the base of natural logarithms with a value of 2.718. The e^x key or the $\boxed{\text{INV}}$ and $\boxed{\ln x}$ keys on your calculator make it easy to evaluate this exponential term.

Charging from Zero The formula for the special case in which an increasing exponential voltage curve begins at zero ($V_i = 0$) is given in Equation (13–20). It is developed as follows, starting with the general formula, Equation (13–18).

$$\begin{aligned} v &= V_F + (V_i - V_F)e^{-t/\tau} \\ &= V_F + (0 - V_F)e^{-t/RC} \\ &= V_F - V_F e^{-t/RC} \\ v &= V_F(1 - e^{-t/RC}) \end{aligned} \quad (13-20)$$

Using Equation (13–20), you can calculate the value of the charging voltage of a capacitor at any instant of time if it is initially uncharged. The same is true for an increasing current.

EXAMPLE 13–12 In Figure 13–32, determine the capacitor voltage $50 \mu\text{s}$ after the switch is closed if the capacitor is initially uncharged. Sketch the charging curve.

FIGURE 13–32

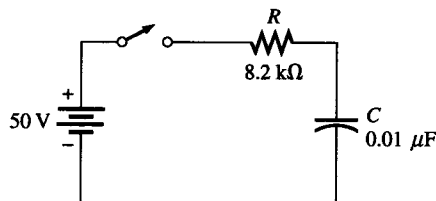

Solution The time constant is $RC = (8.2 \text{ k}\Omega)(0.01 \mu\text{F}) = 82 \mu\text{s}$. The voltage to which the capacitor will fully charge is 50 V (this is V_F). The initial voltage is zero. Notice that $50 \mu\text{s}$ is less than one time constant; so the capacitor will charge less than 63% of the full voltage in that time.

$$\begin{aligned} v_C &= V_F(1 - e^{-t/RC}) = (50 \text{ V})(1 - e^{-50\mu\text{s}/82\mu\text{s}}) \\ &= (50 \text{ V})(1 - e^{-0.61}) = (50 \text{ V})(1 - 0.543) = 22.8 \text{ V} \end{aligned}$$

Determine the value of $e^{-0.61}$ on the calculator by entering -0.61 and then pressing the $\boxed{2\text{nd}} \boxed{e^x}$ keys (or $\boxed{\text{INV}}$ and then $\boxed{\ln x}$ on some calculators). e^x may or may not be a secondary function on your calculator.

The charging curve for the capacitor is shown in Figure 13–33.

FIGURE 13–33

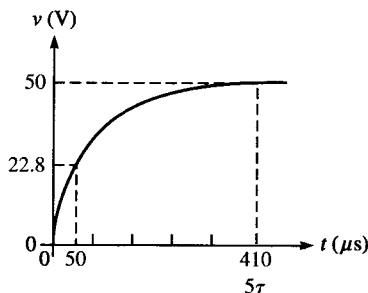

The calculator sequence is

$\boxed{5} \boxed{0} \boxed{+} \boxed{8} \boxed{2} \boxed{=} \boxed{+/-} \boxed{2\text{nd}} \boxed{e^x} \boxed{+/-} \boxed{+} \boxed{1} \boxed{=} \boxed{\times} \boxed{5} \boxed{0} \boxed{=}$

Related Exercise Determine the capacitor voltage $15 \mu\text{s}$ after switch closure in Figure 13–32.

Discharging to Zero The formula for the special case in which a decreasing exponential voltage curve ends at zero ($V_F = 0$) is derived from the general formula as follows:

$$\begin{aligned} v &= V_F + (V_i - V_F)e^{-t/\tau} \\ &= 0 + (V_i - 0)e^{-t/RC} \end{aligned}$$

$$v = V_i e^{-t/RC} \quad (13-21)$$

where V_i is the voltage at the beginning of the discharge as shown in Figure 13–31(b). You can use this formula to calculate the discharging voltage at any instant, as Example 13–13 illustrates.

EXAMPLE 13-13 Determine the capacitor voltage in Figure 13-34 at a point in time 6 ms after the switch is closed. Sketch the discharging curve.

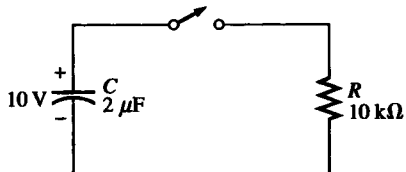

FIGURE 13-34

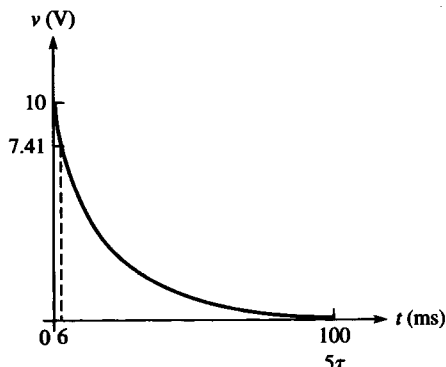

FIGURE 13-35

Solution The discharge time constant is $RC = (10 \text{ k}\Omega)(2 \text{ }\mu\text{F}) = 20 \text{ ms}$. The initial capacitor voltage is 10 V. Notice that 6 ms is less than one time constant, so the capacitor will discharge less than 63%. Therefore, it will have a voltage greater than 37% of the initial voltage at 6 ms.

$$V_C = V_i e^{-t/RC} = 10e^{-6\text{ms}/20\text{ms}} = 10e^{-0.3} = 10(0.741) = 7.41 \text{ V}$$

Again, the value of $e^{-0.3}$ can be determined with a calculator.

The discharging curve for the capacitor is shown in Figure 13-35.

Related Exercise In Figure 13-34, change R to 2.2 k Ω and determine the capacitor voltage 1 ms after the switch is closed.

Graphical Method Using Universal Exponential Curves The universal curves in Figure 13-36 provide a graphic solution of the charge and discharge of capacitors. Example 13-14 illustrates this graphical method.

FIGURE 13-36
Normalized universal exponential curves.

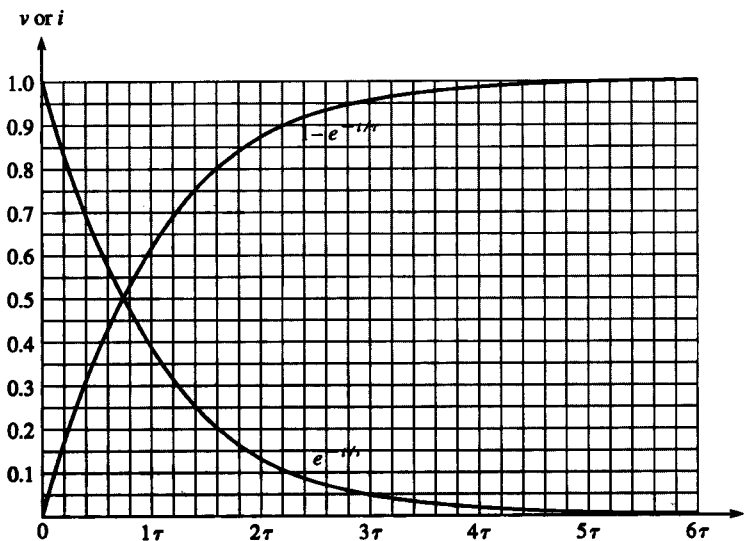

21-3 ■ REPETITIVE-PULSE RESPONSE OF RC INTEGRATORS

In the last section, you learned how an RC integrator responds to a single-pulse input. These basic ideas are extended in this section to include the integrator response to repetitive pulses. In electronic systems, you will encounter repetitive-pulse waveforms much more often than single pulses. However, an understanding of the integrator's response to single pulses is necessary in order to understand how these circuits respond to repeated pulses.

After completing this section, you should be able to

- Analyze an RC integrator with repetitive input pulses
 - Determine the response when the capacitor does not fully charge or discharge
 - Define *steady state*
 - Describe the effect of an increase in time constant on circuit response

If a **periodic** pulse waveform is applied to an RC integrator, as shown in Figure 21-12, the output waveshape depends on the relationship of the circuit time constant and the frequency (period) of the input pulses. The capacitor, of course, charges and discharges in response to a pulse input. The amount of charge and discharge of the capacitor depends both on the circuit time constant and on the input frequency, as mentioned.

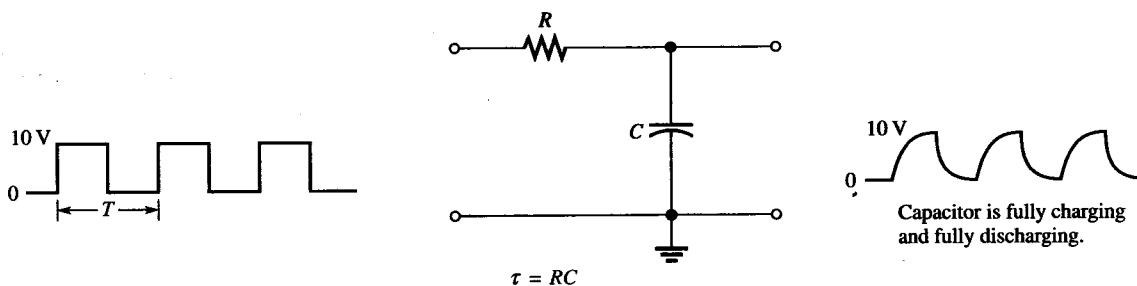

FIGURE 21-12
RC integrator with a repetitive pulse waveform input.

If the pulse width and the time between pulses are each equal to or greater than five time constants, the capacitor will fully charge and fully discharge during each period of the input waveform. This case is shown in Figure 21-12.

When the Capacitor Does Not Fully Charge and Discharge

When the pulse width and the time between pulses are shorter than five time constants, as illustrated in Figure 21-13 for a square wave, the capacitor will *not* completely charge or discharge. We will now examine the effects of this situation on the output voltage of the RC integrator.

FIGURE 21-13
Input waveform that does not allow full charge or discharge of the capacitor in an RC integrator.

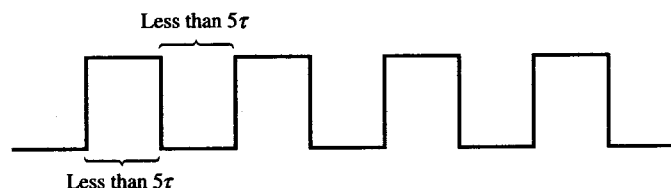

REPETITIVE-PULSE RESPONSE OF RC INTEGRATORS ■ 877

For illustration, let's use an RC integrator with a charging and discharging time constant equal to the pulse width of a 10 V square wave input, as in Figure 21–14. This choice will simplify the analysis and will demonstrate the basic action of the integrator under these conditions. At this point, we really do not care what the exact time constant value is because we know from Chapter 13 that an RC circuit charges approximately 63% during one time constant interval.

FIGURE 21–14
Integrator with a square wave input having a period equal to two time constants ($T = 2\tau$).

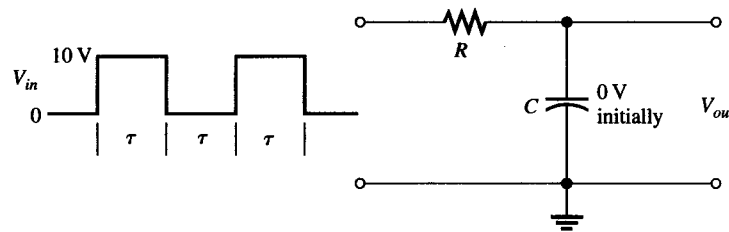

Let's assume that the capacitor in Figure 21–14 begins initially uncharged and examine the output voltage on a pulse-by-pulse basis. The results of this analysis are shown in Figure 21–15.

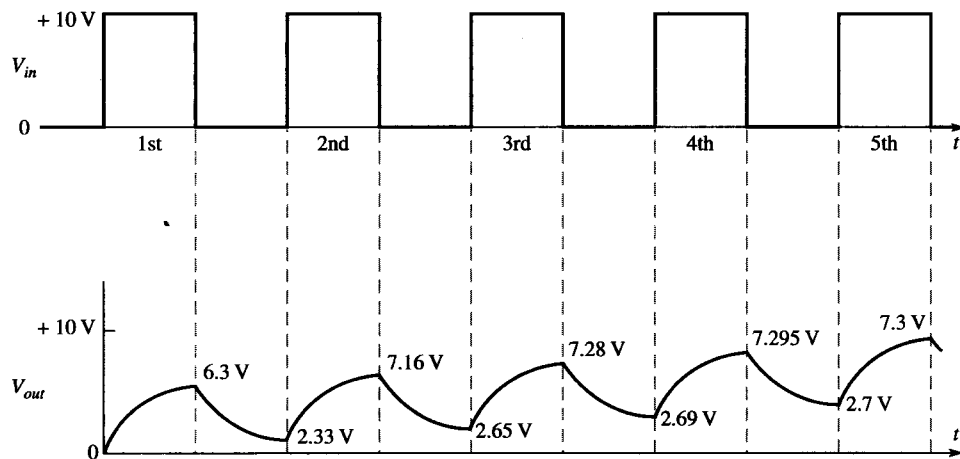

FIGURE 21–15
Input and output for the initially uncharged integrator in Figure 21–14.

First pulse During the first pulse, the capacitor charges. The output voltage reaches 6.3 V (63% of 10 V), as shown in Figure 21–15.

Between first and second pulses The capacitor discharges, and the voltage decreases to 37% of the voltage at the beginning of this interval: $0.37(6.3 \text{ V}) = 2.33 \text{ V}$.

Second pulse The capacitor voltage begins at 2.33 V and increases 63% of the way to 10 V. This calculation is as follows: The total charging range is $10 \text{ V} - 2.33 \text{ V} = 7.67 \text{ V}$. The capacitor voltage will increase an additional 63% of 7.67 V, which is 4.83 V. Thus, at the end of the second pulse, the output voltage is $2.33 \text{ V} + 4.83 \text{ V} = 7.16 \text{ V}$, as shown in Figure 21–15. Notice that the average is building up.

Between second and third pulses The capacitor discharges during this time, and therefore the voltage decreases to 37% of the initial voltage by the end of the second pulse: $0.37(7.16 \text{ V}) = 2.65 \text{ V}$.

Third pulse At the start of the third pulse, the capacitor voltage begins at 2.65 V. The capacitor charges 63% of the way from 2.65 V to 10 V: $0.63(10 \text{ V} - 2.65 \text{ V}) = 4.63 \text{ V}$. Therefore, the voltage at the end of the third pulse is $2.65 \text{ V} + 4.63 \text{ V} = 7.28 \text{ V}$.

Between third and fourth pulses The voltage during this interval decreases due to capacitor discharge. It will decrease to 37% of its value by the end of the third pulse. The final voltage in this interval is $0.37(7.28 \text{ V}) = 2.69 \text{ V}$.

Fourth pulse At the start of the fourth pulse, the capacitor voltage is 2.69 V. The voltage increases by $0.63(10 \text{ V} - 2.69 \text{ V}) = 4.605 \text{ V}$. Therefore, at the end of the fourth pulse, the capacitor voltage is $2.69 \text{ V} + 4.605 \text{ V} = 7.295 \text{ V}$. Notice that the values are leveling off as the pulses continue.

Between fourth and fifth pulses Between these pulses, the capacitor voltage drops to $0.37(7.295 \text{ V}) = 2.7 \text{ V}$.

Fifth pulse During the fifth pulse, the capacitor charges $0.63(10 \text{ V} - 2.7 \text{ V}) = 4.6 \text{ V}$. Since it started at 2.7 V, the voltage at the end of the pulse is $2.7 \text{ V} + 4.6 \text{ V} = 7.3 \text{ V}$.

Steady-State Response

In the preceding discussion, the output voltage gradually built up and then began leveling off. It takes approximately 5τ for the output voltage to build up to a constant average value. This interval is the transient time of the circuit. Once the output voltage reaches the average value of the input voltage, a **steady-state** condition is reached which continues as long as the periodic input continues. This condition is illustrated in Figure 21–16 based on the values obtained in the preceding discussion.

The transient time for our example circuit is the time from the beginning of the first pulse to the end of the third pulse. The reason for this interval is that the capacitor voltage at the end of the third pulse is 7.28 V, which is about 99% of the final voltage.

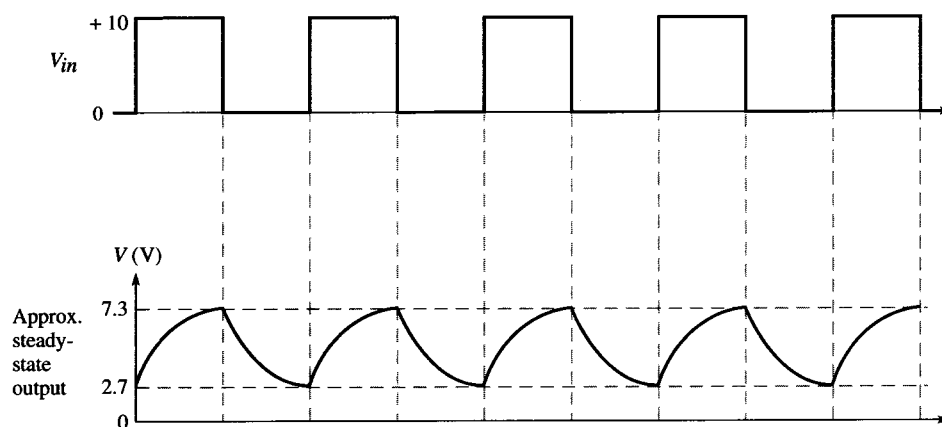

FIGURE 21–16
Output reaches steady state after 5τ .

The Effect of an Increase in Time Constant

What happens to the output voltage if the RC time constant of the integrator is increased with a variable resistor, as indicated in Figure 21–17? As the time constant is increased, the capacitor charges less during a pulse and discharges less between pulses. The result is a smaller fluctuation in the output voltage for increasing values of time constant, as shown in Figure 21–18.

As the time constant becomes extremely long compared to the pulse width, the output voltage approaches a constant dc voltage, as shown in Figure 21–18(c). This value is the average value of the input. For a square wave, it is one-half the amplitude.

FIGURE 21-17
Integrator with a variable time constant.

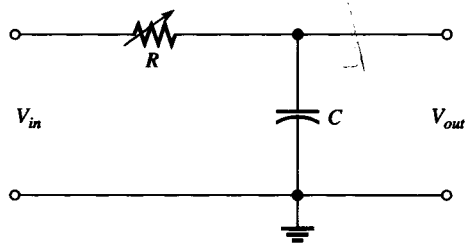
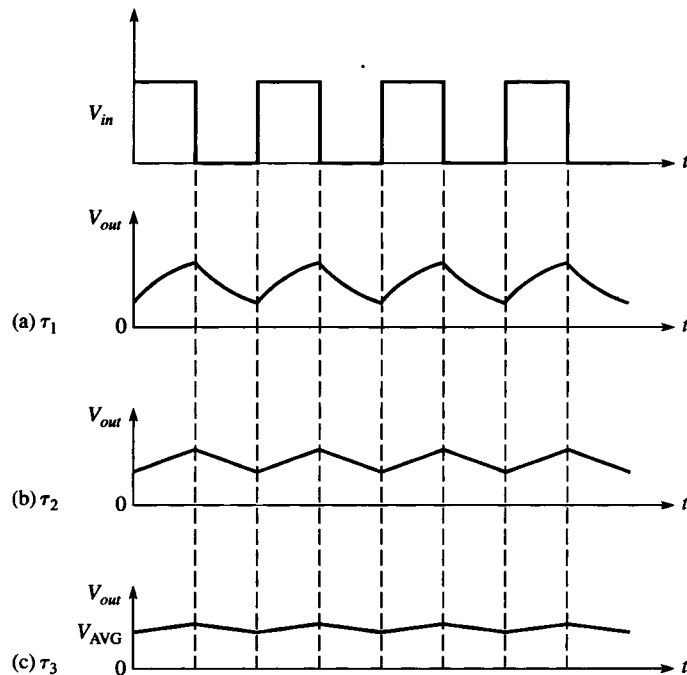

FIGURE 21-18
Effect of longer time constants on the output of an integrator ($\tau_3 > \tau_2 > \tau_1$).



EXAMPLE 21-3

Determine the output voltage waveform for the first two pulses applied to the integrator circuit in Figure 21-19. Assume that the capacitor is initially uncharged and the rheostat is set to $5\text{ k}\Omega$.

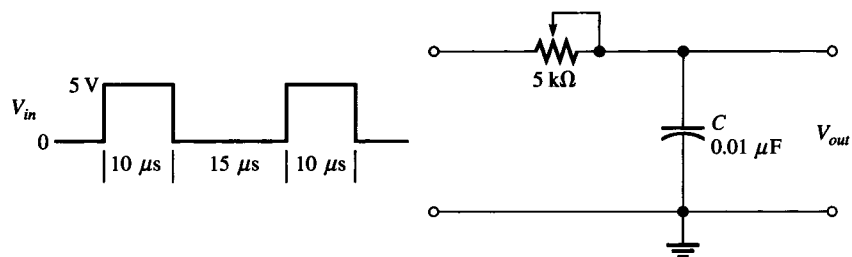

FIGURE 21-19

Solution First calculate the circuit time constant.

$$\tau = RC = (5\text{ k}\Omega)(0.01\text{ }\mu\text{F}) = 50\text{ }\mu\text{s}$$

Obviously, the time constant is much longer than the input pulse width or the interval between pulses (notice that the input is not a square wave). Thus, in this case, the exponential formulas must be applied, and the analysis is relatively difficult. Follow the solution carefully.

1. *Calculation for first pulse:* Use the equation for an increasing exponential because C is charging. Note that V_F is 5 V, and t equals the pulse width of $10\ \mu\text{s}$. Therefore,

$$\begin{aligned} v_C &= V_F(1 - e^{-t/RC}) = (5\ \text{V})(1 - e^{-10\ \mu\text{s}/50\ \mu\text{s}}) \\ &= (5\ \text{V})(1 - 0.819) = 906\ \text{mV} \end{aligned}$$

This result is plotted in Figure 21–20(a).

FIGURE 21–20

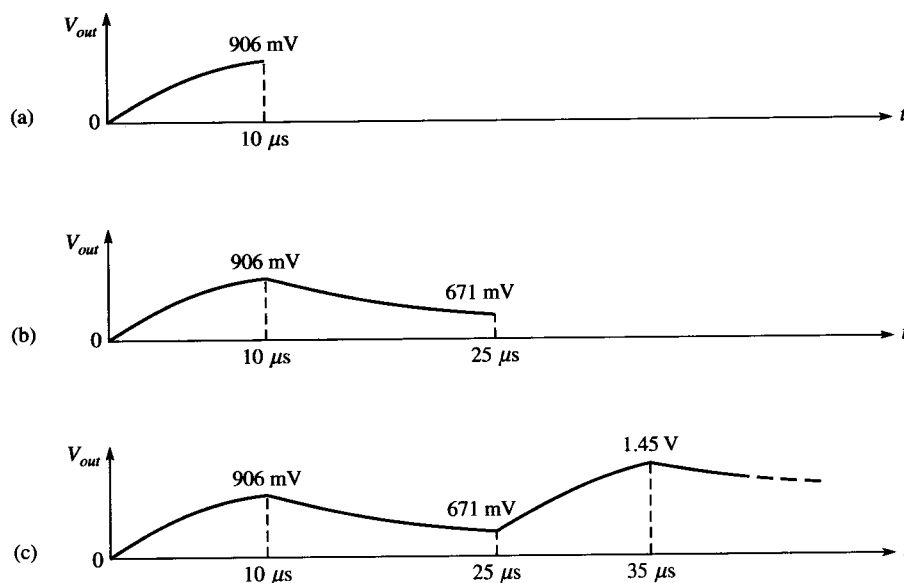

2. *Calculation for interval between first and second pulse:* Use the equation for a decreasing exponential because C is discharging. Note that V_i is 906 mV because C begins to discharge from this value at the end of the first pulse. The discharge time is $15\ \mu\text{s}$. Therefore,

$$\begin{aligned} v_C &= V_i e^{-t/RC} = (906\ \text{mV})e^{-15\ \mu\text{s}/50\ \mu\text{s}} \\ &= (906\ \text{mV})(0.741) = 671\ \text{mV} \end{aligned}$$

This result is shown in Figure 21–20(b).

3. *Calculation for second pulse:* At the beginning of the second pulse, the output voltage is 671 mV. During the second pulse, the capacitor will again charge. In this case, it does not begin at zero volts. It already has 671 mV from the previous charge and discharge. To handle this situation, you must use the general exponential formula.

$$v = V_F + (V_i - V_F)e^{-t/\tau}$$

Using this equation, you can calculate the voltage across the capacitor at the end of the second pulse as follows:

$$\begin{aligned} v_C &= V_F + (V_i - V_F)e^{-t/RC} \\ &= 5\ \text{V} + (671\ \text{mV} - 5\ \text{V})e^{-10\ \mu\text{s}/50\ \mu\text{s}} \\ &= 5\ \text{V} + (-4.33\ \text{V})(0.819) = 5\ \text{V} - 3.55\ \text{V} = 1.45\ \text{V} \end{aligned}$$

This result is shown in Figure 21–20(c).

Notice that the output waveform builds up on successive input pulses. After approximately 5τ , it will reach its steady state and will fluctuate between a constant maximum and a constant minimum, with an average equal to the average value of the input. You can see this pattern by carrying the analysis in this example further.

Related Exercise Determine V_{out} at the beginning of the third pulse.