

EXHIBIT D

United States Patent [19]

[11] **Patent Number:** **6,067,349**

Suder et al.

[45] **Date of Patent:** **May 23, 2000**

[54] **DIALING USING CALLER ID** 5,717,741 2/1998 Yue et al. 379/67

[75] Inventors: **Eric G. Suder; Harold E. A. Hansen II**, both of Plano, Tex.

Primary Examiner—Scott L. Weaver
Attorney, Agent, or Firm—Kelly K. Kordzik; Winstead Sechrest & Minick P.C.

[73] Assignee: **Estech Systems, Inc.**, Plano, Tex.

[57] **ABSTRACT**

[21] Appl. No.: **09/002,205**

A telephone and voice mail (voice processing) system, which is implemented using only a single processing system for controlling operation of both the telephone system and the voice mail system, permits a user to call back a party using caller ID data stored with a voice mail message left by the party calling into the system. This is accomplished by storing caller ID information associated with an incoming call along with the message placed by the incoming caller and stored within the mailbox associated with the called party. Additionally, the caller ID information may be used to create a speed dial list within the telephone and voice mail system for later use by the user. Such caller ID information may be retrieved from a voice mail message left by the calling party, or may be retrieved while conducting a conversation with the incoming call.

[22] Filed: **Dec. 31, 1997**

[51] **Int. Cl.**⁷ **H04M 1/64**

[52] **U.S. Cl.** **379/88.19; 379/88.21; 379/142; 379/355**

[58] **Field of Search** 379/67.1, 88.12, 379/88.19, 88.2, 88.21, 88.22, 88.27, 142, 355

[56] **References Cited**

U.S. PATENT DOCUMENTS

- 4,930,152 5/1990 Miller 379/214
- 5,283,818 2/1994 Klausner et al. 379/67
- 5,671,269 9/1997 Egan et al. 379/88

31 Claims, 14 Drawing Sheets

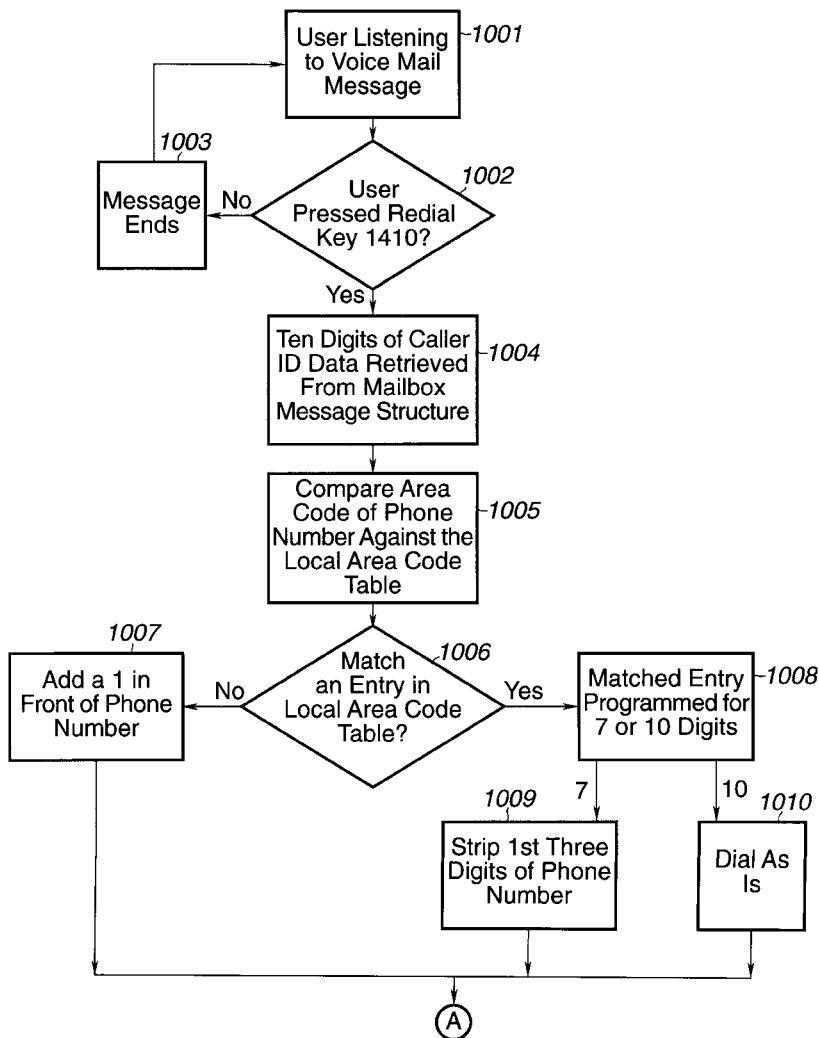

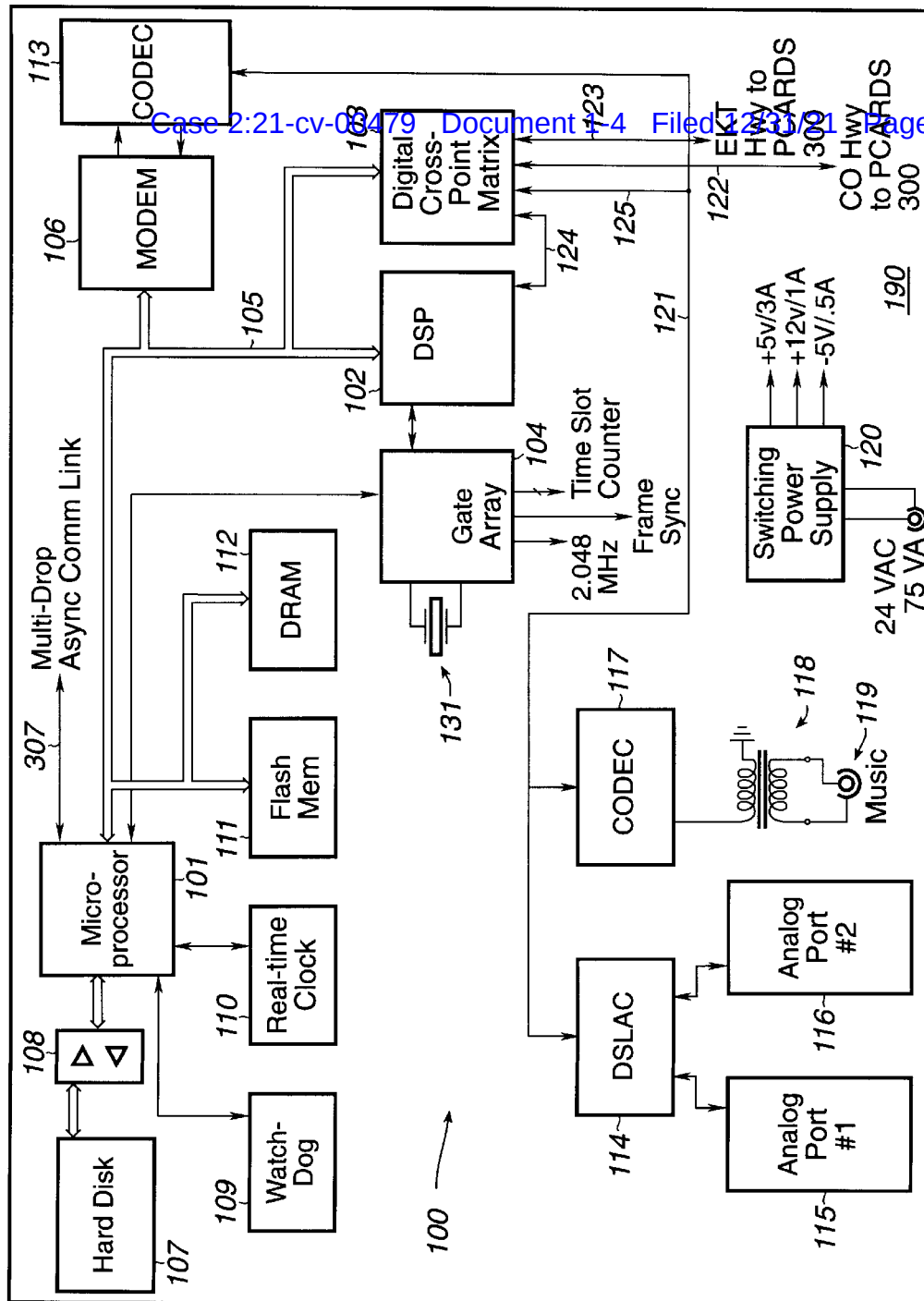

Fig. 1

Case 2:21-cv-03479 Document 1-4 Filed 12/23/21 Page 3 of 23 PageID #: 103

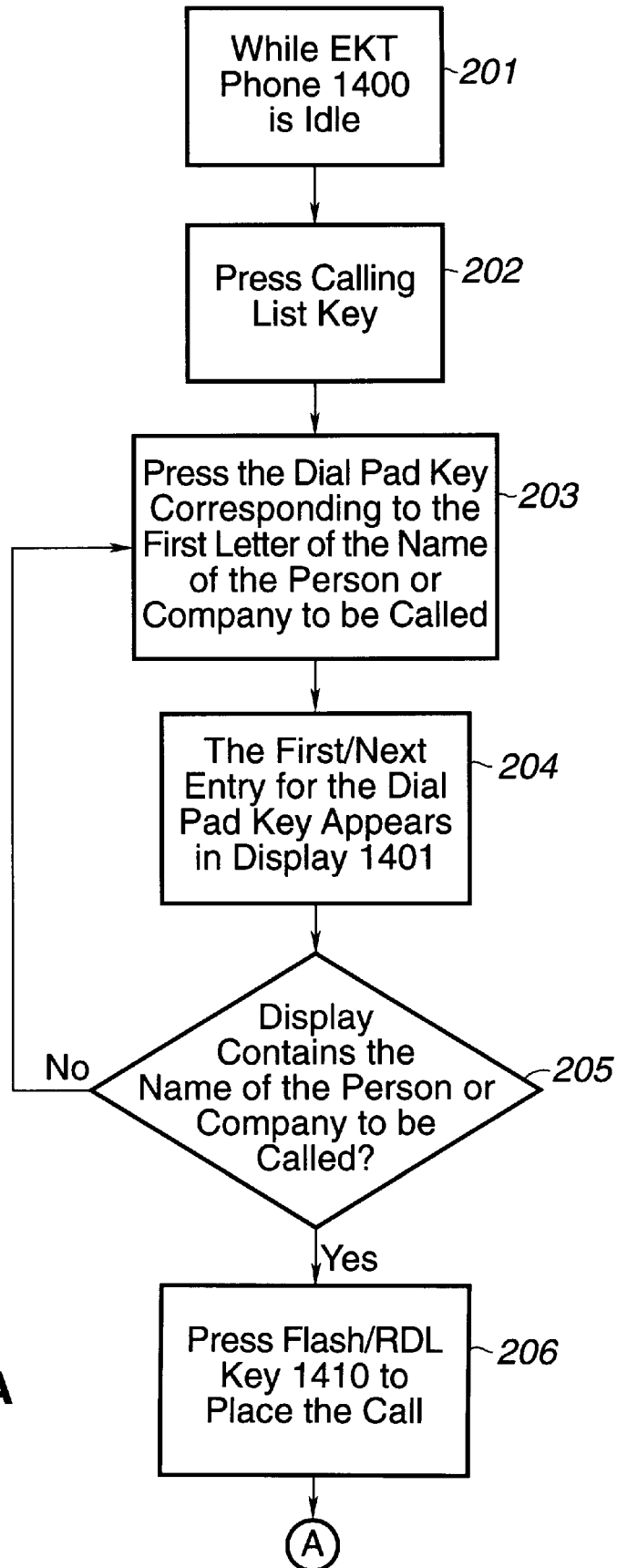
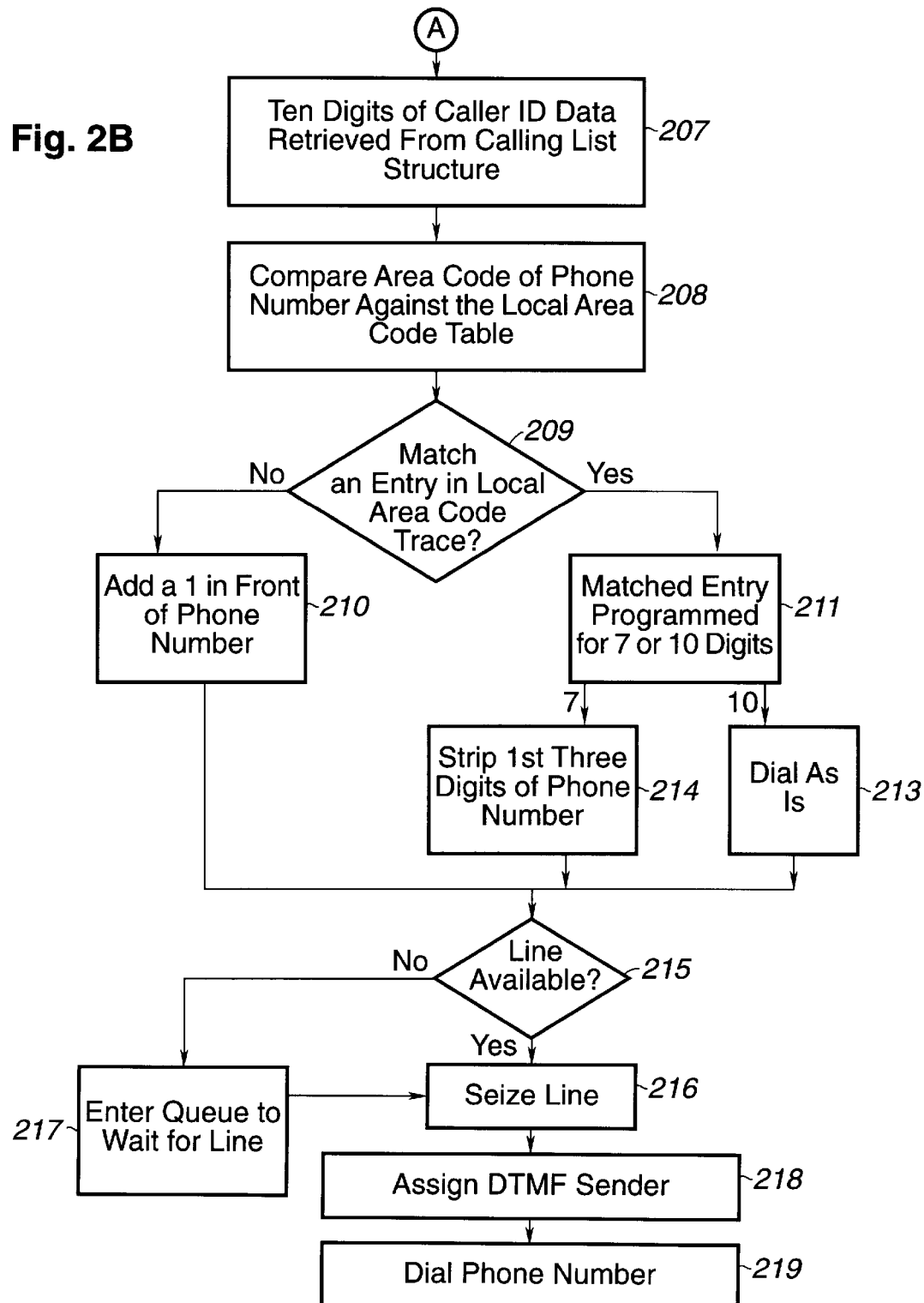

Fig. 2A

Fig. 2B



Explore Litigation Insights

Docket Alarm provides insights to develop a more informed litigation strategy and the peace of mind of knowing you're on top of things.

Real-Time Litigation Alerts



Keep your litigation team up-to-date with **real-time alerts** and advanced team management tools built for the enterprise, all while greatly reducing PACER spend.

Our comprehensive service means we can handle Federal, State, and Administrative courts across the country.

Advanced Docket Research



With over 230 million records, Docket Alarm's cloud-native docket research platform finds what other services can't. Coverage includes Federal, State, plus PTAB, TTAB, ITC and NLRB decisions, all in one place.

Identify arguments that have been successful in the past with full text, pinpoint searching. Link to case law cited within any court document via Fastcase.

Analytics At Your Fingertips



Learn what happened the last time a particular judge, opposing counsel or company faced cases similar to yours.

Advanced out-of-the-box PTAB and TTAB analytics are always at your fingertips.

API

Docket Alarm offers a powerful API (application programming interface) to developers that want to integrate case filings into their apps.

LAW FIRMS

Build custom dashboards for your attorneys and clients with live data direct from the court.

Automate many repetitive legal tasks like conflict checks, document management, and marketing.

FINANCIAL INSTITUTIONS

Litigation and bankruptcy checks for companies and debtors.

E-DISCOVERY AND LEGAL VENDORS

Sync your system to PACER to automate legal marketing.