

## **BULKY DOCUMENTS**

(Exceeds 300 pages)

**Proceeding/Serial No: 92049332**

**Filed: 8-5-09**

**Title: STK, LLC, V. BACKRACK, INC.**

**Part 1 of 4**



Processed by Curtis Puryear

3000 Two Logan Square  
Eighteenth and Arch Streets  
Philadelphia, PA 19103-2799  
215.981.4000  
Fax 215.981.4750

Paul J. Kennedy  
direct dial: 215-981-4194  
direct fax: 215-981-4750  
kennedyp@pepperlaw.com

August 5, 2009

**VIA U.S. EXPRESS MAIL**  
**MAILING LABEL NO. EV 823088705 US**

United States Patent and Trademark Office  
Trademark Trial and Appeal Board  
P.O. Box 1451  
Alexandria, VA 22313-1451

RE: *STK, LLC v. BACKRACK, INC.*  
Cancellation No. 92049332  
Mark: BACKRACK, Registration No. 3,014,986

Dear Sir or Madam:

Enclosed please find the following documents for filing:

1. Registrant's Memorandum of Law in Opposition to Petitioner's Motion for Summary Judgment and in Support of Registrant's Cross-Motion for Summary Judgment;
2. Declaration of Adrian Jayne in Support of Registrant's Opposition to Petitioner's Motion for Summary Judgment and in Support of Registrant's Cross-Motion for Summary Judgment with Exhibits;
3. Declaration of J. Anthony Lovensheimer with Exhibits; and



08-05-2009

U.S. Patent & Trademark Office

United States Patent and Trademark Office  
Trademark Trial and Appeal Board  
August 5, 2009  
Page 2

4. Certificate of Mailing and Service.

Sincerely yours,

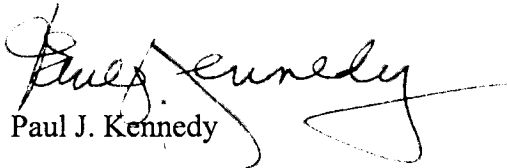

Paul J. Kennedy

PJK/tc  
Enclosures

cc: John M. Adams, Esquire  
(w/enclosures via U.S. First Class Mail)

**IN THE UNITED STATES PATENT AND TRADEMARK OFFICE  
BEFORE THE TRADEMARK TRIAL AND APPEAL BOARD**

---

STK, LLC	:	
	:	
Petitioner	:	Cancellation No. 92049332
	:	
	:	Mark: BACKRACK
	:	
v.	:	Registration No. 3014986
	:	
	:	Filed: February 24, 2004
BACKRACK, INC.	:	Registered: November 15, 2005
	:	
Registrant/Respondent	:	

---

**CERTIFICATE OF MAILING AND SERVICE**

**CERTIFICATE OF MAILING**

U.S. EXPRESS MAIL  
MAILING LABEL NO. EV 823088705 US

DATE OF DEPOSIT: August 5, 2009

I, PAUL J. KENNEDY, hereby certify that:

1. Registrant's Memorandum of Law in Opposition to Petitioner's Motion for Summary Judgment and in Support of Registrant's Cross-Motion for Summary Judgment;

2. Declaration of Adrian Jayne in Support of Registrant's Opposition to Petitioner's Motion for Summary Judgment and in Support of Registrant's Cross-Motion for Summary Judgment with Exhibits; and

3. Declaration of J. Anthony Lovensheimer with Exhibits,

are being deposited with the United States Postal Service "Express Mail Post Office to Addressee" service under 37 CFR §1.10 on the date indicated above and is addressed to the United States Patent and Trademark Office, Trademark Trial and Appeal Board, P.O. Box 1451, Alexandria, Virginia 22313-1451.

**CERTIFICATE OF SERVICE**

I, PAUL J. KENNEDY, hereby certify that on August 5, 2009, true and correct copies of the foregoing (1) Registrant's Memorandum of Law in Opposition to Petitioner's Motion for Summary Judgment and in Support of Registrant's Cross-Motion for Summary Judgment; (2) Declaration of Adrian Jayne in Support of Registrant's Opposition to Petitioner's Motion for Summary Judgment and in Support of Registrant's Cross-Motion for Summary Judgment with Exhibits; and (3) Declaration of J. Anthony Lovensheimer with Exhibits was served upon counsel for Petitioner, STK, LLC, by U.S. First Class Mail, postage prepaid, as follows:

John M. Adams, Esquire  
PRICE AND ADAMS, PC  
4135 Brownsville Road  
P.O. Box 98127  
Pittsburgh, PA 15227  
*Attorneys for Petitioner  
STK, LLC*

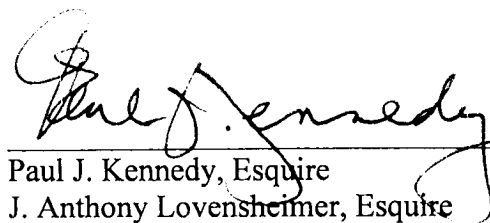

Paul J. Kennedy, Esquire  
J. Anthony Lovensheimer, Esquire  
PEPPER HAMILTON LLP  
3000 Two Logan Square  
Eighteenth & Arch Streets  
Philadelphia, PA 19103-2799  
Tel: (215) 981-4000  
Fax: (215) 981-4750

Dated: August 5, 2009

*Attorneys for Registrant  
Backrack, Inc.*

**IN THE UNITED STATES PATENT AND TRADEMARK OFFICE  
BEFORE THE TRADEMARK TRIAL AND APPEAL BOARD**

---

STK, LLC

Petitioner

v.

BACKRACK, INC.

Registrant/Respondent

---

:  
:  
: Cancellation No. 92049332  
:  
: Mark: BACKRACK  
:  
: Registration No. 3014986  
:  
: Filed: February 24, 2004  
: Registered: November 15, 2005  
:  
:

**REGISTRANT'S MEMORANDUM OF LAW IN OPPOSITION TO  
PETITIONER'S MOTION FOR SUMMARY JUDGMENT AND  
IN SUPPORT OF REGISTRANT'S CROSS-MOTION FOR SUMMARY JUDGMENT**

Paul J. Kennedy  
J. Anthony Lovensheimer  
PEPPER HAMILTON LLP  
3000 Two Logan Square  
Eighteenth & Arch Streets  
Philadelphia, PA 19103-2799  
Tel.: (215) 981-4000  
Fax: (215) 981-4750

*Attorneys for Respondent  
Backrack, Inc.*

## TABLE OF CONTENTS

	<u>Page</u>
I. INTRODUCTION.....	1
II. STATEMENT OF FACTS.....	1
III. ARGUMENT .....	5
A. Summary Judgment Standard .....	5
B. Registrant’s BACKRACK Mark Is Not Generic.....	6
1. The Term BACKRACK Is Not A “Compound Word” .....	7
2. Registrant Has Properly Used The BACKRACK Mark.....	9
3. Third Party Use And Understanding Of The BACKRACK Mark .....	13
4. Registrant Has Consistently Policed Use Of The BACKRACK Mark.....	14
5. Petitioner Has Provided No Admissible Evidence Of Consumer Understanding Of The BACKRACK Mark .....	16
C. The Board Should Not Consider Petitioner’s Exhibits And Testimony.....	19
IV. CONCLUSION .....	21

## TABLE OF AUTHORITIES

	<b>Page(s)</b>
<b>CASES</b>	
<i>Bellsouth Corp. v. Datanational Corp.</i> , 60 F.3d 1565, 35 U.S.P.Q.2d 1554 (Fed. Cir. 1995) .....	16
<i>Berner Int'l. Corp. v. Mars Sales Co.</i> , 987 F.2d 975, 26 U.S.P.Q.2d 1044 (3rd Cir 1993) .....	16
<i>Birtcher Electro Medical Systems, Inc. v. Beacon Laboratories, Inc.</i> , 738 F. Supp. 417, 16 U.S.P.Q.2d 1411 (D. Colo. 1990) .....	12
<i>Caesar's World, Inc. v. Milanian</i> , 247 F. Supp. 2d 1171 (D. Nev. 2003) .....	18
<i>Celotex Corp. v. Catrett</i> , 477 U.S. 317 (1986) .....	5
<i>Colt Defense LLC v. Bushmaster Firearms, Inc.</i> , 2005 U.S. Dist. LEXIS 20874 (D. Maine 2005) .....	12
<i>Copelands' Entes, Inc. v. CNV Inc.</i> , 20 U.S.P.Q.2d 1295 (Fed. Cir. 1991) .....	5
<i>CPC International, Inc. v. Balzola Foods Corp.</i> , 224 U.S.P.Q. 85 (S.D. Fla. 1984) .....	10, 11
<i>Cummins Engine Co., Inc. v. Continental Motors Corp.</i> , 359 F.2d 892, 149 U.S.P.Q. 559 (CCPA 1966) .....	8
<i>Grooms v. Legge</i> , 2009 U.S. Dist. LEXIS 43526 (S.D. Cal. May 22, 2009) .....	19
<i>H. Marvin Ginn Corp. v. International Association of Fire Chiefs, Inc.</i> , 782 F.2d 987, 228 U.S.P.Q. 528 (Fed. Cir. 1986) .....	6
<i>In the Matter of ABCOR Development Corp.</i> , 588 F.2d 811, 200 U.S.P.Q. 215 (CCPA 1978) .....	8
<i>In re American Fertility Society</i> , 188 F.3d 1341, 51 U.S.P.Q.2d 1832 (Fed. Cir. 1999) .....	6, 8
<i>In re Dial-A-Mattress</i> , 240 F.3d 1341, 57 U.S.P.Q.2d 1807 (Fed. Cir. 2001) .....	8
<i>In re Dugger</i> , 2005 TTAB LEXIS 462 (Serial No. 78207954) (TTAB October 27, 2005) .....	20
<i>In re Gould Paper Corp.</i> , 834 F.2d 1017, 5 U.S.P.Q.2d 1110 (Fed. Cir. 1987) .....	7, 8
<i>In re Merrill Lynch, Pierce, Fenner, and Smith, Inc.</i> , 828 F.2d 1567, 4 U.S.P.Q.2d 1141 (Fed. Cir. 1987) .....	6, 7, 14
<i>In re Montrachet S.A.</i> , 878 F.2d 375, 11 U.S.P.Q.2d 1393 (Fed. Cir. 1989) .....	6
<i>In re Northland Aluminum Products, Inc.</i> , 777 F.2d 1556, 227 U.S.P.Q. 961 (Fed. Cir. 1985) .....	7
<i>In re Steelbuilding.com</i> , 415 F.3d 1293, 75 U.S.P.Q. 2d 1420 (Fed. Cir. 2005) .....	8



<i>Liberto v. D.F. Stauffer Biscuit Co., Inc.</i> , 441 F.3d 318, 77 U.S.P.Q.2d 1981 (5th Cir. 2006) .....	16
<i>Magic Wand Inc. v. RDB, Inc.</i> , 940 F.2d 638, 19 U.S.P.Q.2d 1551 (Fed. Cir. 1991) .....	7, 17
<i>National Nonwovens v. Consumer Products Enterprises, Inc.</i> , 397 F. Supp. 2d 245, 78 U.S.P.Q.2d 1526 (D. Mass. 2005).....	12
<i>Olde Tyme Foods Inc. v. Roundy's Inc.</i> , 961 F.2d 200, 22 U.S.P.Q.2d 1542 (Fed. Cir. 1992) .....	5
<i>Opryland USA Inc. v. The Great American Music Show Inc.</i> , 970 F.2d 847, 23 U.S.P.Q.2d 1471 (Fed. Cir. 1992) .....	5
<i>Raccioppi v. Apogee Inc.</i> , 47 U.S.P.Q.2d 1368 (TTAB 1998) .....	20
<i>Sweats Fashions Inc. v. Pannill Knitting Co., Inc.</i> , 833 F.2d 1560, 4 U.S.P.Q.2d 1793 (Fed. Cir. 1987) .....	5
<i>Ty Inc. v. Softbelly's Inc.</i> , 353 F.3d 528 (7th Cir. 2003) .....	7
<i>Zimmerman v. Nat'l. Assoc. of Realtors</i> , 70 U.S.P.Q.2d 1425 (TTAB 2004) .....	6, 7
<b>OTHER AUTHORITIES</b>	
Federal Rule of Civil Procedure 56 .....	5, 19, 20, 21

## **I. INTRODUCTION**

Registrant Backrack, Inc. (“Registrant”), through its undersigned counsel, hereby submits Registrant’s Memorandum in Opposition to Petitioner’s Motion for Summary Judgment (“Petitioner’s Motion”) and in Support of Registrant’s Cross-Motion for Summary Judgment (“Registrant’s Cross-Motion”).

This matter is a cancellation proceeding brought by Registrant’s disgruntled competitor, whose affiliated company had served as Registrant’s primary U.S. distributor for thirteen years. That prior relationship is now the subject of a collection lawsuit. Notwithstanding Petitioner’s retaliatory motivation, Petitioner’s Motion lacks merit because Petitioner fails to provide any evidence (admissible or otherwise) to establish that Registrant’s registered trademark BACKRACK<sup>®</sup> (hereinafter “BACKRACK Mark”) is recognized by the relevant consuming public as the name for a genus of goods rather than as an indicator of Registrant as the source for quality pickup truck accessories.

To the contrary, the undisputed evidence establishes: (1) Registrant’s consistent use of the BACKRACK Mark as a source identifier for quality pickup truck accessories; (2) non-use of the BACKRACK Mark by Registrant’s competitors, including Petitioner; and (3) the industry’s consistent and exclusive use of the BACKRACK Mark as Registrant’s brand name. Therefore, Petitioner fails to meet the very high burden required to prove that the BACKRACK Mark has become generic because the undisputed evidence confirms that the BACKRACK Mark is a strong trademark associated exclusively with Registrant. Therefore, Petitioner’s Motion should be denied and Registrant’s Cross-Motion for summary judgment granted.

## **II. STATEMENT OF FACTS**

Adrian Jayne and his father, Gil Jayne, started Backrack in 1988 to develop and manufacture pickup truck accessories, including the patented headache rack/cab guard invented by Gil Jayne. *See* Declaration of Adrian Jayne (“Jayne Dec.”) at ¶ 4, Ex. 1. The BACKRACK Mark was conceived by Gil Jayne in 1988 and has been used continuously ever since. *Id.* at ¶ 5.

Before and after Registrant adopted the BACKRACK Mark, no manufacturers had ever used the term “backrack” in connection with pickup truck accessories. *Id.* at ¶¶ 6-7, 69, Ex. 40.

Registrant obtained a federal trademark registration for the BACKRACK Mark in 2005 (Registration No. 3014986). *See* Declaration of J. Anthony Lovensheimer (“Love. Dec.”) at Ex. L. BACKRACK products have been advertised, offered for sale, and sold throughout the United States by Registrant, and by Registrant’s distributors, since 1989 through catalog and other retail advertising, point of sale advertising at various sales and distribution outlets, and through the Internet. *Jayne Dec.* at ¶ 9.

From 1994 through 2007, Backrack’s primary distributor in the United States was Armor Deck LLC (“Armor Deck”), which was (and continues to be) owned by Petitioner’s majority owner, Steve Setteducati (“Setteducati”). *Id.* at ¶ 13. Armor Deck is Petitioner’s “Featured Partner”. *Love. Dec.* at Ex. H (Registrant’s Requests for Admission at Ex. F) and Ex. J (Petitioner’s Answers Requests for Admission Nos. 58-59). Armor Deck advertised and used the BACKRACK Mark as a trademark for 13 years without protest or challenge. *See Jayne Dec.* at ¶ 14. However, the relationship changed due to a pricing dispute in late 2007. *Id.* at ¶ 15, Ex. 2.

After the dispute arose, Petitioner announced its plan to introduce virtually identical copies of the BACKRACK line of headache racks/cab guards: the PRO RACK and PRO GUARD in October 2007. *Id.* at ¶¶ 16, 25. Armor Deck has advertised and sold Petitioner’s headache racks/cab guards since their introduction. *Id.* at ¶ 17, Ex. 3. Thus, ever since October 2007, Petitioner has been one of Backrack’s principal competitors. *Id.* at ¶ 18.

Due to various issues involving Petitioner and its affiliate, Armor Deck, Backrack ended its relationship with Armor Deck. *Id.* Backrack has since sued Armor Deck to recover money owed to it. *Id.* at ¶ 20. Only after Backrack initiated the collection suit, did Petitioner institute the present cancellation proceeding. *Id.* at ¶ 21.<sup>1</sup>

---

<sup>1</sup> Petitioner and Armor Deck have extensively advertised Petitioner’s products in print and Internet advertisements. *Id.* at ¶¶ 22-24, Exs. 4-8; *Love. Dec.* at Ex. H (Registrant’s Admission Requests Exs. D-G) and Ex. J (Petitioner’s Answers to Admission Requests Nos. 58 and 64). Neither Petitioner nor Armor Deck uses the term “backrack” in any variation to identify or  
(continued...)

Registrant has advertised BACKRACK products through print advertisements including, but not limited to flyers, pamphlets, product guides, and point of sale advertisements. *Id.* at ¶ 27. BACKRACK products have also been advertised through numerous Internet websites, including but not limited to those owned by Registrant. *Id.* at ¶ 51, Ex. 26. Registrant also prominently displays the BACKRACK Mark in large white font which effectively serve as moving billboards advertising the BACKRACK Mark. *Id.* at ¶ 28.

Registrant has also made and provided pre-approved advertising materials to its distributors. *Id.* at ¶¶ 29, 49-50, Exs. 24 and 25. This material has been made available via the Internet, through email or through a CD Rom. *Id.* Registrant created this content to create a more uniform presentation of the BACKRACK brand and to ensure proper use and marking of the BACKRACK Mark in such materials. *Id.* Registrant's distributors can modify the templates as necessary to fit within its catalog or other printed/digital advertising material. *Id.* at ¶ 30.

Registrant has consistently utilized the BACKRACK Mark in its advertisements in a manner where in the overall context, it is apparent to consumers that BACKRACK is a brand name for the pickup truck accessories depicted. *Id.* at ¶ 31. Registrant has done so through the use of a variety of techniques, including: (1) use of a "TM" designation; (2) prominent use of the BACKRACK Mark in a banner heading; (3) use of images of the BACKRACK Mark applied to products; (4) use of generic product names such as "truck rack" or "cab guard" with BACKRACK; (5) use of all or initial capital letters; (6) use of bold font; and (7) use of larger font size. *Id.* at ¶¶ 31-50, Exs. 10-25. Registrant has also used the notice "BACKRACK IS A TRADEMARK OF BACKRACK INC." in its advertising. *Id.* at

---

(continued...)

describe Petitioner's products. *Id.* Instead, they only use the brand names, PRO RACK and PRO GUARD, and the generic product names, "cab racks," "cab guards" and "truck racks." *Id.*

¶¶ 42, 44-46, Exs. 18, 20-22. Registrant has also applied a decal with the BACKRACK Mark marked with a “TM” to all BACKRACK headache racks/cab guards since 1988. *Id.* at ¶ 32, Ex. 9.

BACKRACK products are also advertised at numerous third-party websites where BACKRACK products are typically categorized as “cab guards”, “truck headache racks”, “headache racks”, “truck racks”, or “window guards”. *Id.* ¶¶ 56-68, Exs. 28-39; *see also* Love. Dec. at Exs. A1-A7, A9, A11, A12, A14-A34. Third parties, including Armor Deck, also consistently use the BACKRACK Mark as the source identification. *See* Jayne Dec. at ¶¶ 40, 53-55, 61-65, 67-68, 70, 80-81, Exs. 16, 27, 32-36, 38-39, 41, 50 and 51; *see also* Love. Dec. at Exs. A1-A7, A9, A10-11, A13-34.

Other manufacturers of similar products are also identified as “cab guard,” “cab rack,” or “cab protector.” *See* Jayne Dec. at ¶ 69, Ex. 40. None of them use the term “backrack” in any manner. *Id.* Armor Deck continued to advertise BACKRACK products along with Petitioner’s under the general category “cab guards”. *Id.* at ¶ 53, Ex. 27.

Registrant’s counsel monitors the Internet and U.S. and Canadian trademark registries to identify potentially confusing or improper use of BACKRACK. *Id.* at ¶ 71. Registrant has stopped numerous third parties from using the BACKRACK Mark in potentially damaging ways, and protected its trademark rights through opposition proceedings. *See Id.* at ¶¶ 72-77, Exs. 42-48. Two parties that Registrant has had to pursue are companies with whom Petitioner has stated that it has a “confidential” business relationship. *See Id.* at ¶¶ 74-75; Love. Dec. at Ex. I (Petitioner’s Answers to Respondent’s Second Set of Interrogatories and Requests for Production of Documents Addressed to Petitioner at Nos. 18 and 21). Indeed, Petitioner lists both parties on its website under “FEATURED AUTOMOTIVE RELATED LINKS.” *See* Jayne Dec. at ¶ 75; Love. Dec. at Ex. H (Registrant’s Admission Requests Ex. F) and Ex. J (Petitioner’s Answers to Admission Requests No. 58). Registrant has also recovered domain names, including one from Armor Deck. *See* Jayne Dec. at ¶ 52, Ex. 26.

The term “backrack” is also used for unrelated goods and services, but Backrack has taken no action against these uses. *Id.* at ¶ 78, Ex. 49; Love. Dec. at Exs. B4-B28. The articles

discovered in Nexis search reports demonstrated no use of “backrack” or “back rack” in connection with trucks other than three references to Registrant. *See Love. Dec. at Exs. B1-B28.*

After 20 years of extensive advertising and development, BACKRACK identifies the source of quality pickup truck accessories originating from Registrant. *See Jayne Dec. at ¶ 84.*

Registrant’s competitors have not adopted the term “backrack”, nor have distributors identified any general category of goods as the “backrack”: instead; the generic terms “headache rack,” “cab guard,” or “truck rack” are used to describe the general type of products. *Id. at Exs. 4-7, 40; see also Love. Dec. at Exs. A1-A34.* Petitioner’s retaliatory petition to cancel Registrant’s BACKRACK Mark would destroy the value and goodwill of Registrant’s BACKRACK Mark established through Registrant’s 20 years of exclusive use.

### **III. ARGUMENT**

#### **A. Summary Judgment Standard**

Summary judgment is appropriate for disposing of cases in which there are no genuine issues of material fact in dispute, thus leaving the matter to be resolved as a matter of law. Fed. R. Civ. P. 56(c). The party moving for summary judgment bears the initial burden of demonstrating the absence of any genuine issue of material fact and that it is entitled to judgment as a matter of law. *See Celotex Corp. v. Catrett*, 477 U.S. 317 (1986); *Copelands’ Entes. Inc. v. CNV Inc.*, 20 U.S.P.Q.2d 1295, 1297-8 (Fed. Cir. 1991); *Sweats Fashions Inc. v. Pannill Knitting Co., Inc.*, 833 F.2d 1560, 1562, 4 U.S.P.Q.2d 1793 (Fed. Cir. 1987); TBMP § 528.01.

To establish that a genuine factual dispute exists, “the nonmoving party ‘need only present evidence from which a jury might return a verdict in [its] favor.’” *Olde Tyme Foods Inc. v. Roundy’s Inc.*, 961 F.2d 200, 202, 22 U.S.P.Q.2d 1542 (Fed. Cir. 1992) (quoting *Anderson v. Liberty Lobby, Inc.*, 477 U.S. 242, 257 (1986)). The Board may not resolve issues of material fact against the non-moving party; it may only ascertain whether such issues are present. *See Opryland USA Inc. v. The Great American Music Show Inc.*, 970 F.2d 847, 850, 23 U.S.P.Q.2d 1471, 1472 (Fed. Cir. 1992).

The undisputed facts of record establish that there are no genuine issues of material fact as to: (1) Registrant's consistent and exclusive use of the BACKRACK Mark to indicate the source of pickup truck accessories; (2) use of the BACKRACK Mark as a source identifier for Registrant's goods by the automotive parts industry (including Petitioner and its affiliate, Armor Deck); (3) the availability and use of generic names to describe the parties' goods, including "headache racks", "cab guards" and "truck racks"; and (4) the complete lack of evidence of any third party use of the term "backrack" in connection with truck accessories other than as a source identifying reference to Registrant.

The evidence upon which Petitioner attempts to rely to overcome the clear weight of dispositive evidence supporting Registrant's Cross-Motion is not only unpersuasive but predominately inadmissible because it is either unauthenticated or inadmissible hearsay. As a result, for the reasons set forth below, the Board should not consider the proffered evidence in the present motions. However, even if the Board were to consider Petitioner's evidence, the overwhelming weight of all the relevant evidence weighs decidedly in Registrant's favor. Therefore, Registrant, not Petitioner, is entitled to judgment as a matter of law that the BACKRACK Mark is not generic. As a result, the Board should deny Petitioner's Motion and grant Registrant's Cross-Motion.

**B. Registrant's BACKRACK Mark Is Not Generic**

The Board employs a two-part test to determine genericness: (1) What is the class of goods or services at issue?; and (2) Does the relevant public understand the designation primarily to refer to that class of goods or services? *H. Marvin Ginn Corp. v. International Association of Fire Chiefs, Inc.*, 782 F.2d 987, 990, 228 U.S.P.Q. 528, 530 (Fed. Cir. 1986). *See also In re American Fertility Society*, 188 F.3d 1341, 51 U.S.P.Q.2d 1832 (Fed. Cir. 1999).

The critical issue is whether members of the relevant public primarily use or understand the term to refer to the genus or category of goods or services in question. *See In re Montrachet S.A.*, 878 F.2d 375, 11 U.S.P.Q.2d 1393, 1394 (Fed. Cir. 1989); *In re Merrill Lynch, Pierce, Fenner, and Smith, Inc.*, 828 F.2d 1567, 4 U.S.P.Q.2d 1141 (Fed. Cir. 1987); and *Zimmerman v. Nat'l. Assoc. of Realtors*, 70 U.S.P.Q.2d 1425 (TTAB 2004). Petitioner bears the burden of proving that the BACKRACK Mark has

become generic by a preponderance of the evidence. *Magic Wand Inc. v. RDB, Inc.*, 940 F.2d 638, 19 U.S.P.Q.2d 1551 (Fed. Cir. 1991); *Zimmerman*, 70 U.S.P.Q.2d at 1425. However, the Board should also be mindful that “To determine that a trademark is generic and thus pitch it into the public domain is a fateful step.” *Ty Inc. v. Softbelly’s Inc.*, 353 F.3d 528, 531 (7th Cir. 2003).

Evidence of the relevant public’s understanding of a term may be obtained from any competent source, including testimony, surveys, dictionaries, trade journals, newspapers, and other publications. *See In re Northland Aluminum Products, Inc.*, 777 F.2d 1556, 227 U.S.P.Q. 961 (Fed. Cir. 1985). *See also Magic Wand*, 940 F.2d at 640, 19 U.S.P.Q.2d at 1553; and *Merrill Lynch*, 828 F.2d at 1570, 4 U.S.P.Q.2d at 1142. Petitioner fails to provide any evidence of this and as a result fails to meet its challenging burden of proof by failing to establish that the BACKRACK Mark is understood by the relevant public primarily to refer to the genus of goods rather than as the source of the particular goods. In fact, the evidence of record establishes the opposite: the BACKRACK Mark is used and understood by the relevant public to refer only to Registrant as the source of the relevant goods.<sup>2</sup>

**1. The Term BACKRACK Is Not A “Compound Word”**

Petitioner misguidedly attempts to minimize the glaring evidentiary shortcomings of its case by asserting that it should be held to a lower standard of proof pursuant to *In re Gould Paper Corp.*, 834 F.2d 1017, 5 U.S.P.Q.2d 1110 (Fed. Cir. 1987). Petitioner’s attempt to interject the *Gould* analysis to this matter is inappropriate and unsupported by any evidence.<sup>3</sup>

The *Gould* test is only applicable, however, to “compound terms formed by the union of words” where the public understands the individual terms to be generic for a genus of goods or services, and the joining of the individual terms into one compound word lends “no additional meaning to the

---

<sup>2</sup> The genus of goods at issue are the goods recited in the registration namely “Pick-up truck racks, namely, headache racks designed to protect the cab and mount a variety of accessories, namely, light, antenna and toolbox brackets. *See Magic Wand*, 940 F.2d at 640, 19 U.S.P.Q.2d at 1552.

<sup>3</sup> For the reasons discussed *infra* at Section C, Registrant maintains that Petitioner has failed to properly introduce any dictionary references to “back” or “rack” because the dictionary relied on by Petitioner is only available on-line at [www.thefreedictionary.com](http://www.thefreedictionary.com) and the printouts attached at Petitioner’s Ex. 6 (Exs. A and B) have not been properly authenticated.



term.” *In re Dial-A-Mattress*, 240 F.3d 1341, 1345, 57 U.S.P.Q.2d 1807 (Fed. Cir. 2001) (Board reversed, 1-800-M-A-T-R-E-S-S held not generic). Under *Gould*, the burden of proving the term generic can be met by producing evidence that each of the constituent words is generic, and that “the separate words joined to form a compound have a meaning identical to the meaning common usage would ascribe to those words as a compound.” *Gould*, 834 F.2d at 1018, 5 U.S.P.Q.2d at 1110.

Here, Petitioner has failed on both counts. Petitioner has failed to produce any evidence that each of the constituent terms “back” and “rack” is generic for the relevant goods and failed to provide any evidence of the public’s understanding of BACKRACK as the composite term. Moreover, the definitions relied on by Petitioner (to the extent that they are even admissible) make *no reference* to any pickup truck or pickup truck accessories. Indeed, the dictionary entries alone provide no basis for the conclusion that BACKRACK is generic for the relevant goods. Therefore, BACKRACK is not a compound word that can be rendered generic based solely on Petitioner’s tortured interpretation of the definitions of the constituent terms pursuant to the holding in *Gould*.

The cases relied on by Petitioner provide no support for Petitioner’s position. *See e.g. In re Steelbuilding.com*, 415 F.3d 1293, 75 U.S.P.Q. 2d 1420 (Fed. Cir. 2005) (genericness finding reversed because, *inter alia*, the Board “erroneously . . . discounted the ambiguities and multiple meanings in the mark . . .”); *In re American Fertility Society*, 188 F.3d 1341, 51 U.S.P.Q. 2d 1832 (Fed. Cir. 1999) (Board incorrectly assumed genericness of the whole term based solely on proof of the genericness of its individual terms when no evidence of the relevant public’s understanding of the phrase as a whole provided).<sup>4</sup>

---

<sup>4</sup> Petitioner also relies on *In the Matter of ABCOR Development Corp.*, 588 F.2d 811, 200 U.S.P.Q. 215 (CCPA 1978) and *Cummins Engine Co., Inc. v. Continental Motors Corp.*, 359 F.2d 892, 149 U.S.P.Q. 559 (CCPA 1966); however, both cases are inapplicable. In *ABCOR*, the CCPA reversed the genericness holding. In *Cummins*, the CCPA relied on extensive evidence, not just basic dictionary definitions (unlike Petitioner), to determine that the term TURBODIESEL was “a natural composite term for designating such engines.”

## **2. Registrant Has Properly Used The BACKRACK Mark**

Registrant has consistently used the BACKRACK Mark in its advertising materials to make the relevant public aware that BACKRACK is a source of goods. As set forth in the extensive Declaration of Adrian Jayne, Registrant's President, and the attached advertising examples, Registrant has used the BACKRACK Mark so that within the context of each advertisement, it is clear that Registrant's BACKRACK Mark identifies the specific goods originating from Registrant, not a general category of goods. *See* Jayne Dec. at ¶¶ 31-50, Exs. 10-25. In particular, Registrant has routinely marked the BACKRACK Mark with a "TM" symbol or otherwise set off the BACKRACK Mark through a combination of capitalization, font size or style along with use of the images of the products themselves bearing the BACKRACK Mark as installed on vehicles. *Id.* at ¶ 31, Exs. 10-25. The advertisements used by Registrant through the years overwhelmingly demonstrate that BACKRACK is the source of the particular goods advertised and not a generic type of good. *Id.*

In addition to all of the various techniques utilized by Registrant mentioned above, Registrant has also used an explicit trademark notice "BACKRACK IS A TRADEMARK OF BACKRACK INC." in its advertising. *Id.* at ¶¶ 42, 44-46, Exs. 18, 20-22. Registrant has also applied a decal bearing the BACKRACK Mark marked with the "TM" designation to all BACKRACK headache racks/cab guards since the first sale in 1988. *Id.* at ¶ 32, Ex. 9. These additional elements erase all doubt as to how the relevant public perceives the BACKRACK Mark within the context of Registrant's advertising.

The commercial context of many of these advertisements within the marketplace further confirm the use of BACKRACK as a brand and not as a type of good. For example, in the advertisement for BACKRACK products which appeared in the 1996 Buyer's Guide Issue of the trade magazine, *Trailer Body Builders*, the advertisement appeared along with other manufacturers on the page under the general product category "Cab Protectors." *Id.* at ¶ 40, Ex. 16. Several other BACKRACK advertisements also appeared in catalogs prepared by distributors in which the BACKRACK Mark is clearly used to identify one source of the general products known as headache racks, cab guards or cab

protectors. *Id.* at ¶¶ 40, 53-55, 61-65, 67-68, 70, 80-81, Exs. 16, 27; 32-36, 38-39, 41, 50 and 51; *see also* Love. Dec. at Exs. A1-A34. This categorization is also made evident to consumers by the index and table of contents of third party catalogs. *See e.g.* Jayne Dec. at Exs. 50-51.

Petitioner's attack on the advertisements used by Registrant's distributors also fails for the same reasons. Indeed, in many cases, Registrant's distributors utilized advertising materials that Registrant made available to them either through e-mail or through Registrant's Internet Website.<sup>5</sup> *See Id.* at ¶¶ 29, 49-50, Exs. 24 and 25.

Rather than present any admissible or credible direct evidence of the relevant public's understanding of the BACKRACK Mark, Petitioner rests its claim almost exclusively on Registrant's alleged misuse of the BACKRACK Mark. *See* Petitioner's Motion at 10-12. Rather than assess Registrant's use of the BACKRACK Mark within the context of Registrant's advertising materials, as experienced by the relevant public, Petitioner asserts that the BACKRACK Mark has become generic simply by being used as a noun in selected excerpts from advertisements for BACKRACK products. Petitioner's reliance on dissected excerpts from Registrant's advertising text – taken completely out of the context – does nothing to prove how the relevant public views and understands the BACKRACK Mark.<sup>6</sup>

Contrary to Petitioner's repeated assertion, it is not mandatory that a trademark owner engage in redundancy in its advertising or promotional literature by following every use of its trademark with the generic words for the product. *CPC International, Inc. v. Balzola Foods Corp.*, 224 U.S.P.Q. 85 (S.D. Fla. 1984) (Term MAZOLA held not a generic name for corn oil). Indeed, as McCarthy has noted:

---

<sup>5</sup> Remarkably, Petitioner refers to Armor Deck (which is also owned by the same principal, Steve Setteducati) as "one former distributor" throughout Petitioner's Motion. *See e.g.* Petitioner's Motion at 18. Despite Petitioner's attempt to distance itself from these advertisements, these simply confirm that even Petitioner considered the BACKRACK Mark to be a source indicator for Registrant's products. Petitioner's attempt to use the advertisements as a weapon in its attempt to destroy the BACKRACK Mark that it was more than willing to promote and use to its benefit for thirteen years, is disingenuous and should be dismissed.

<sup>6</sup> Petitioner's own actions belie this assertion since, as noted, Petitioner's PRO RACK and PRO GUARD products are advertised in precisely the same manner. *See* Love. Dec. at Ex. H (Registrant's Admission Requests Exs.D, G) and Ex. J (Petitioner's Answers to Admission Requests No.23). While Mr. Setteducati claims to have "learned that it was improper to use a trademark as a noun in an advertisement", Petitioner's advertisements clearly show that that Petitioner *does* use their marks as nouns. *Id.*

Failure to be 100% consistent in all advertising does not result in sudden genericness and loss of trademark rights like dropping an egg. *Context of usage* can often supply the generic name.

McCarthy on Trademarks § 12:27 (emphasis added). The *CPC International* court further held that “[i]t is sufficient that the viewer is made aware that the word is a trademark by the association of the mark with generic words in a context of normal literary style.” *CPC International*, 224 U.S.P.Q. at 87. See also *Maremont*, 463 F.2d at 1114 (Holding LOAD-CARRIER for shock absorbers not generic even though applicant used the phrase “Gabriel® LOAD-CARRIER” with no other information as to what the product was although there was a picture of the product on the box.). The *Maremont* court further stated that the picture of the product in connection with the text took the place of the generic name.

Petitioner’s attempt to portray Registrant’s use of the BACKRACK Mark as “inconsistent” fails because the record demonstrates that within the context of each advertisement, Registrant has consistently used a wide variety of techniques to distinguish the BACKRACK Mark and to make it clear that the BACKRACK Mark is a trademark that identifies Registrant as the source of the products shown. While Petitioner focuses on purported inconsistencies in the techniques used by Registrant by extracting isolated uses from advertising pieces, the Board should consider each advertisement in context to determine how the relevant public would perceive the BACKRACK Mark because that is precisely how the relevant public has experienced these materials. When that is done, there can be no doubt that Registrant’s use of the BACKRACK Mark constitutes proper use of the BACKRACK Mark as a trademark.

The cases relied on by Petitioner simply provide no guidance because each of the cases cited by Petitioner included significantly different fact patterns and significantly more evidence than Petitioner has presented here. These cases make Petitioner’s complete dearth of evidence abundantly clear. Moreover, the results in these cases are not based solely on the purported use of the trademark as a noun in advertising excerpts (as is the foundation of Petitioner’s Motion), but instead are based on extensive evidence from a wide variety of categories, including: (1) third-party use; (2) media use; (3)

generic combined words used with their generic meanings; and (4) the lack of alternative terms for competitors to use.

For example:

- In *Colt Defense LLC v. Bushmaster Firearms, Inc.*, 2005 U.S. Dist. LEXIS 20874 (D. Maine 2005), the court found the term “M4” a generic descriptor for a military style handgun on the basis of extensive evidence, including: (1) extensive generic use by customers; (2) extensive generic use in trade journals and magazines; (3) extensive use of the M4 designation by numerous weapons manufacturers other than Colt; and (4) use by Colt as a generic descriptor such as “the M4 *type* rifles and carbines” (including similar use of the M4 description in a patent). (emphasis added).
- In *Birtcher Electro Medical Systems, Inc. v. Beacon Laboratories, Inc.*, 738 F. Supp. 417, 16 U.S.P.Q.2d 1411 (D. Colo. 1990) the purported trademark owner never sought a registration for the term or used the term as a trademark and even went so far as to actually remove the “TM” designation from advertisements before releasing it to the public. The active removal of the trademark designation combined with the additional evidence (first product of its type and thus purported trademark was the only name available for the product and articles showing generic usage) resulted in the finding that the term Argon Coagulator Beam for a beam of argon gas used to coagulate blood during operations. *Id.*
- In *National Nonwovens v. Consumer Products Enterprises, Inc.*, 397 F. Supp. 2d 245, 78 U.S.P.Q.2d 1526 (D. Mass. 2005), the court held the term WOOLFELT to be generic for “fabric, namely, felt consisting of wool” based on the following: (1) the terms “wool” and “felt” were used in the same manner as they are defined and when combined, they were merely a combined term that signified a particular “category or class of felt”; (2) extensive evidence of generic use by the owner and third parties; (3) extensive evidence of generic use of the term in books and magazines; (4) generic use of the term in government documents; and (4) extensive evidence of generic use of the term on the Internet. *Id.* at 253.

Therefore, rather than support the propositions set forth by Petitioner, these cases actually demonstrate the substantial evidence required to successfully prove by a preponderance of the evidence that a trademark is generic. And, in contrast, Petitioner does not come close to meeting this significant burden by simply relying on excerpts from BACKRACK advertising materials when the advertising materials viewed in context, make it abundantly clear that the BACKRACK Mark is used and understood as a source identifier for Registrant’s goods.<sup>7</sup>

---

<sup>7</sup> Petitioner’s assertion that “Registrant’s attorneys essentially conceded that STK is entitled to summary judgment in its response to an earlier motion” is nonsense as there is no such conclusion and of no moment given the foregoing discussion.

**3. Third Party Use And Understanding Of The BACKRACK Mark**

The evidence of record establishes that there is no use of BACKRACK in connection with the relevant goods by any entity other than Registrant and that those within the industry, including Petitioner and Petitioner's affiliate, Armor Deck, universally use and understand Registrant as the particular source of pickup truck accessories.

The undisputed evidence also clearly shows that there are no other manufacturers, including Petitioner, who have used the BACKRACK Mark either in the name of its products or as a descriptive term used for their products or the headache rack/cab guards of others. *See* Jayne Dec. at ¶¶ 22-24, 69, Exs. 4-8, 40; Love. Dec. at Ex. H (Registrant's Admission Requests Exs. D-G). Moreover, the undisputed evidence clearly shows that within the industry, the terms "headache rack", "cab guard", "truck rack" and "cab protector" are used as the generic name for the category of goods of which the BACKRACK headache rack/cab guard is but one example. *See* Jayne Dec. at ¶¶ 22-24, 56-69, Exs. 3-8, 28-40; *see also* Love. Dec. at Exs. A1-A34; B1-B3.

The most telling evidence of record in this case concerning the use and understanding of the BACKRACK Mark can be gleaned from Petitioner's own advertisements and those of Petitioner's affiliated company, Armor Deck. As previously referenced, Petitioner and Armor Deck have been selling products virtually identical to those offered by Registrant under the brand names PRO RACK and PRO GUARD since late 2007. *See* Jayne Dec. at ¶¶ 16-18, 22-24, Exs. 3-8; Love. Dec. at Ex. H (Registrant's Admission Requests Exs. D-G) and Ex. J (Petitioner's Answers to Admission Requests Nos. 23, 26, 58 and 64). Yet, at no point has Petitioner used "BACKRACK", in any variation, to identify or describe the PRO RACK or PRO GUARD headache rack/cab guard. *Id.* Instead, Petitioner and Armor Deck have consistently used the generic names "cab racks," "cab guards" and "truck racks" to identify the type of product. *Id.* In addition, Armor Deck consistently uses the generic terms "truck racks" and "cab guards" directly following the BACKRACK Mark when describing the BACKRACK headache rack/cab guard. *See* Love. Dec. Ex. H (Registrant's Admission Requests Ex. G).

This evidence of the industry's use and understanding of BACKRACK is consistent throughout all of the evidence submitted by BOTH parties – the term BACKRACK is used exclusively to refer to the headache rack/cab guard sold by Registrant. *See* Jayne Dec. at ¶¶ 40, 53-55, 61-65, 67-68, 70, 80-81, Exs. 16, 27; 32-36, 38-39, 41, 50 and 51; *see also* Love. Dec. at Exs. A1-A34, B1-B3, Ex. H (Registrant's Admission Requests Exs. D-G). The BACKRACK products are consistently classified within the general product categories "headache rack", "cab guard" or "cab protector". *See* Jayne Dec. at ¶¶ 56-68, Exs. 28-39; *see also* Love. Dec. at Exs. A1-A7, A14-A34. Moreover, the BACKRACK Mark is also consistently referred to by third parties specifically as a "Featured Brand" or in a similar direct source indicator. *See e.g.* Jayne Dec. at Ex. 35. BACKRACK is never used by third parties as a product type or general classification of goods. *See* Jayne Dec. at Exs. 27-41, 50-51; Love. Dec. at Exs. A1-A34.

This use and understanding is further confirmed by the fact that the only relevant uses of BACKRACK in printed articles are in direct reference to Registrant and Registrant's products. *See* Love. Dec. Exs. B1-B3. Moreover, the earliest relevant reference found in the search for "backrack" and "back rack" confirms that there were no relevant references to the terms prior to Registrant's adoption and use of the BACKRACK Mark. *See Id.* at Exs. B1-B28 (earliest reference at Ex. B3 dates from 1997); *See also In re Merrill Lynch*, 828 F.2d at 1571, 4 U.S.P.Q.2d at 1143 (CASH MANAGEMENT ACCOUNT held not generic based on, *inter alia*, publication evidence that established that the term was not used in any printed publications to refer to the services at issue prior to applicant's adoption of the mark).

#### **4. Registrant Has Consistently Policed Use Of The BACKRACK Mark**

Petitioner has consistently and aggressively policed use of the BACKRACK Mark by third parties and enforced its rights against third parties that have attempted to misuse the BACKRACK Mark. Registrant has caused several third parties to cease using the BACKRACK Mark in potentially damaging ways. *See* Jayne Dec. at ¶¶ 52, 72-77, Exs. 26, 42-48. In addition, Petitioner has gone after numerous blog entries in order to have the improper use of the BACKRACK Mark removed. *See Id.* at ¶ 76, Ex. 47. Registrant, through its legal counsel, also monitors the Internet and the trademark registry in

the U.S. and Canada to identify any potentially confusing or improper use of the BACKRACK Mark. *See Jayne Dec. at ¶ 72.*

Contrary to Petitioner's assertion, Registrant's efforts to police the use of the BACKRACK Mark is not a recent phenomenon. Although, due to the actions of several parties that appear to be affiliated or somehow associated with Petitioner, Registrant's efforts have increased substantially recently. Registrant's policing efforts includes an incident in 2006 when Registrant stopped a company called AWATEC from using the BACKRACK Mark improperly in Canada. *See Jayne Dec. at ¶ 72, Ex. 42.* Registrant also caused another third party to enter into an undertaking in which it agreed to cease using the BACKRACK Mark improperly. *Id. at ¶ 73, Exs. 43-44.*

Two recent instances involved the distributors BuyAutoTruckAccessories.com and BigBoysCustomToys.com, both of which are listed on Petitioner's website as "FEATURED AUTOMOTIVE RELATED LINKS." *See Id. at ¶ 74-75; Love. Dec. at Ex. H (Registrant's Admission Requests Ex. F), Ex. I (Petitioner's Answers to Respondent's Second Set of Interrogatories and Requests for Production of Documents Addressed to Petitioner at Nos. 18, 19 and 21).* ). In addition, Petitioner's document production also indicated that one of the blog entries that Registrant stopped, was posted by a media company that was working with Petitioner in connection with this matter. *See Love. Dec. at Ex. M.* Given Petitioner's current position, it is not surprising that the only current misuse of the BACKRACK Mark originates from entities *that are linked to the Petitioner.*

However, regardless of the source of the inappropriate use of the BACKRACK Mark, Registrant has maintained a consistent pattern of preventing third parties from using the BACKRACK Mark inappropriately. Petitioner has provided no evidence that Registrant has failed to stop any use of the BACKRACK Mark similar to those uses described in the letters and e-mails attached to the Jayne Declaration at Exs. 42-48.

Finally, Petitioner's novel argument that the BACKRACK Mark can become the victim of genericide if third parties purchase Google or Yahoo! sponsored links or advertisements for the BACKRACK Mark while not actually selling BACKRACK products rests on shaky legal foundations, is



speculative and simply defies logic. Petitioner's assertion also ignores the reality of the difficulty that trademark owners face in protecting their trademark rights in this ever-changing context and constitutes an unprecedented leap of logic that would result in the mass genericide of thousands of trademarks. Moreover, despite Petitioner's assertions to the contrary, Petitioner has not "obtained evidence that indicates that third parties routinely buy the keyword "backrack" or other similar key words on Internet search engines such as Yahoo! and Google." As discussed below in Section C, Petitioner's "evidence" is inadmissible because it is not authenticated and constitutes inadmissible hearsay. Petitioner's attempt to "testify" through its memorandum of law cannot salvage it.

Registrant's policing efforts have ensured that Registrant's BACKRACK Mark has not become generic.<sup>8</sup>

**5. Petitioner Has Provided No Admissible Evidence Of Consumer Understanding Of The BACKRACK Mark**

Direct consumer evidence, *e.g.*, consumer surveys and testimony is preferable to indirect forms of evidence. *See Berner Int'l. Corp. v. Mars Sales Co.*, 987 F.2d 975, 982, 26 U.S.P.Q.2d 1044 (3rd Cir 1993) ("Consumer surveys have become almost de rigeur in litigation over genericness. Judges are now used to survey evidence and often expect to receive evidentiary assistance by surveys in resolving generic disputes.") (*quoting* 2 McCarthy § 12:2 at 529-30).

To say the least, Petitioner has produced no direct evidence of the relevant public's understanding of the BACKRACK Mark. Instead, Petitioner attempts to represent a collection of 18 e-mails from customers of its affiliate, Armor Deck, as "survey evidence." However, these e-mails are unauthenticated, inadmissible hearsay for the reasons discussed in Section C. Likewise, Petitioner's reliance on postings on the Internet websites Craigslist.com, eBay.com and various purported blogs as

---

<sup>8</sup> The cases relied do not alter Registrant's policing efforts. Reference to *Liberto v. D.F. Stauffer Biscuit Co., Inc.*, 441 F.3d 318, 77 U.S.P.Q.2d 1981 (5th Cir. 2006) is misplaced because Petitioner simply has not, nor could it have, produced the evidence of "widespread usage by competitors" that was found in the *Liberto* case. Petitioner's reliance on *Bellsouth Corp. v. Datanational Corp.*, 60 F.3d 1565, 35 U.S.P.Q.2d 1554 (Fed. Cir. 1995) is also misplaced because in *Bellsouth*, the evidence established that the alleged mark was generic prior to the purported owner's attempt to register the mark because it had never treated the alleged mark (the walking fingers design used in yellow pages) as a trademark and had permitted all publishers to use the mark from the very inception of use of the mark.

direct evidence of consumer understanding of the BACKRACK Mark also fails because they too are unauthenticated and inadmissible hearsay for the reasons discussed in Section C. As such, none of this “evidence” should be considered.

Even if Petitioner could somehow overcome these fundamental evidentiary flaws, Petitioner’s purported “evidence” does not constitute direct evidence of the relevant public’s understanding of the BACKRACK Mark. Petitioner’s collection of e-mails from a total of 18 distributor customers of its affiliated company, Armor Deck, is so flawed that it simply does not, nor could not, constitute a valid survey of the relevant public’s understanding of the BACKRACK Mark. *See* Petitioner’s Ex. 9 (Fourth Setteducati Dec. at Exs. A-R). Thus, Petitioner’s attempt to treat these e-mails as a “survey” truly strains all credibility, therefore, they warrant no consideration.

First, the purported “survey” only went to a handful of customers of the Petitioner’s affiliated company, Armor Deck, all of whom were also distributors of Petitioner’s products, including its two headache rack/cab guards. *See Id.* None of the recipients of the “survey” was a general consumer of pickup truck accessories. As such, the “survey” did not cover the entire relevant public, which, as a result, renders it useless. *See e.g. Magic Wand*, 940 F.2d at 641, 19 U.S.P.Q.2d at 1553 (“[V]endors, operators, and manufacturers are a very small part of the relevant purchasing public. Accordingly evidence of generic use by this small part has limited probative value.”).

Second, the “survey” questions were so hopelessly imprecise that they simply could not yield credible results as to the actual understanding of the relevant public. *See Id.* at ¶¶ 5-6. Even Petitioner recognized these flawed questions and decided to send a second round of equally flawed e-mail questionnaires which revised the original two questions and provided multiple choice responses for the 18 recipients identified by Petitioner. *See Id.* at ¶¶ 9-10, Exs. A-R.

Third, the “survey” only sought information concerning how the customers of these select distributors may have used the BACKRACK Mark when seeking “a BackRack truck rack.” *Id.* As such, the responses provided by these distributors (to the extent that they are even admissible) simply provide NO evidence of how the unknown customers actually understood the BACKRACK Mark when

formulating their request for a “BackRack truck rack.” As such, these “survey” results do not provide any actual evidence of consumer understanding.

Finally, contrary to Petitioner’s assertion, even if the results of this “survey” were considered, they actually support Registrant because the vast majority of customers reported by the recipients (17 out of 18) allegedly used either “BackRack”, “BackRack truck rack”, or “BackRack cab guard” when “looking to buy a BackRack truck rack.” *Id.* at ¶ 30. These results demonstrate the strength of the BACKRACK Mark and the clear understanding that consumers recognize it as the particular brand sought. Petitioner’s president, Mr. Setteducati, as an unqualified “expert”, concedes that these results demonstrate “that there are a few instances whereby Armor Deck’s customers responded that the Back Rack trademark was used properly.” *Id.* However, as McCarthy (a frequently cited expert himself) has stated:

The fact that buyers or users often call for or order a product by a term does not necessarily prove that a term is a “generic name.” The person who orders for lunch a “BIG MAC and a COKE” undoubtedly has brand knowledge and brand loyalty. The generic names “hamburger” and “cola” are understood by all precisely because BIG MAC and COKE are such strong trademarks identifying source. Since everyone knows the generic names, they are dropped in ordinary usage.

2 McCarthy § 12:27 at 12-104. *See also Caesar’s World, Inc. v. Milanian*, 247 F. Supp. 2d 1171, 1195 (D. Nev. 2003). Therefore, contrary to Petitioner’s conclusions to the contrary, these “survey” results do NOT “indicate that an overwhelming majority” of headache rack distributors’ customers understand the BACKRACK to identify “the name of any headache rack or cab guard.”

Petitioner’s purported “evidence” allegedly obtained from Craigslist.com, eBay.com and various blogs also fails to demonstrate the public’s understanding of the BACKRACK Mark. It is hearsay and none of this “evidence” has been authenticated. And, to the extent that the “evidence” is even deemed admissible, and considered by the Board, it does not provide any insight into the mind-set of the individuals who may have posted the advertisements, nor does it establish the scope of dissemination of these advertisements or even if they were ever available or viewed by the relevant public. Therefore,

these printouts do not constitute direct evidence of the consuming public's understanding of the BACKRACK Mark. *See e.g. In re Future First LLC*, Serial Number 78769110 (TTAB 2008).<sup>9</sup>

In *Future First*, the Board deemed this exact type of evidence "of little probative value" because there was "no way of knowing whether some or even many of these excerpts may be referencing applicant's goods." *Id.* The Board also noted: "the fact that an individual posting a comment on a blog or other online forum may use a term without proper capitalization is not necessarily evidence that he or she believes the term is a common commercial name, nor is it evidence that readers of the posting regard it as such." *Id.*

In the present case, many of the samples taken from Craigslist and eBay actually demonstrate that the user is referring to headache racks/cab guards that originate from BACKRACK and include images of BACKRACK products. *See e.g.* Petitioner's Ex. 10 (Exs. D, K and P). Therefore, even if the Board does consider this "evidence", the only clear probative value of the actual evidence (not the testimony of Mr. Setteducati) is to establish that users referring to BACKRACK use the term to designate a particular source for headache racks/cab guards. As discussed above, the fact that a user may use the term BACKRACK by itself without the generic designation like headache rack or cab guard does not constitute an improper use. *See* 2 McCarthy § 12:27 at 12-104.

**C. The Board Should Not Consider Petitioner's Exhibits And Testimony**

The Board should not consider numerous documents and proffered testimony because they are either unauthenticated and/or hearsay and, therefore, do not constitute admissible evidence as required by Federal Rule of Civil Procedure 56. The Board should also not consider improper testimony from Petitioner's President, Steve Setteducati because it constitutes inadmissible hearsay and/or improper "expert" testimony.

---

<sup>9</sup> Petitioner's reliance on *Grooms v. Legge*, 2009 U.S. Dist. LEXIS 43526 \*3 n. 2 (S.D. Cal. May 22, 2009) is misplaced because the case simply provides a definition of "Craigslist.com", but does not consider the admissibility or probative value of the content of an advertisement appearing on the website. Petitioner's reliance on a case in which the Board included classified advertisements is also inapposite because of the fundamental difference between a transitory advertisement on an Internet website and an advertisement that appeared in a printed publication.

The Board should not consider Petitioner's "printouts" as they are not accompanied by an affidavit or declaration of the person who actually accessed the information or an assertion that the printouts were made at the direction of Mr. Setteducati. *See Raccioppi v. Apogee Inc*, 47 U.S.P.Q.2d 1368 (TTAB 1998) (To properly introduce downloaded printouts from the Internet into evidence for purposes of summary judgment, a party must submit such printouts accompanied by an affidavit or declaration of the person who accessed the information).

There are also several of Petitioner's Exhibits that should not be considered by the Board because they are not admissible evidence as required for consideration under Fed. R. Civ. P. 56 (c). These exhibits are: (1) Petitioner's Exhibit 6 (Exhibits A and B); (2) Petitioner's Exhibit 8 (Exhibits A, B, C, E, F and G); (3) Petitioner's Exhibit 9 (All Exhibits); and (4) Petitioner's Exhibit 10 (Exhibits A through W). In addition, Petitioner's Exhibit 6 (Exhibits A and B) includes the definitions of "back" and "rack" taken from [www.thefreeonlinedictionary.com](http://www.thefreeonlinedictionary.com). These should not be considered by the Board because they are not properly authenticated Internet printouts as required under the *Raccioppi* decision, 47 U.S.P.Q.2d 368. Further, the Board should also not take judicial notice of these definitions because they come from a dictionary which is available in electronic form only. *See In re Dugger*, 2005 TTAB LEXIS 462 (Serial No. 78207954) (TTAB October 27, 2005).

In addition, Petitioner's Exhibit 10 (Exhibit S) demonstrates another flaw with all of Petitioner's exhibits in Exhibit 10. They are selected exclusively to support Petitioner's misguided view of proper trademark use. And as a result, Petitioner omits additional Internet printouts which overwhelmingly demonstrate the real use and understanding of BACKRACK by the relevant public. *See Love. Dec. at Exhibits A1-A34*.

As a result, the Board should reject the foregoing testimony and exhibits.

Finally, Petitioner affirmed in its discovery responses that it had not engaged an "expert" and had not undertaken a "survey" in this matter three separate times. *See Love. Dec. at Exhibit E* (Petitioner's Answers to Respondent's First Set of Interrogatories and Requests for Production of Documents Addressed to Petitioner at Interrogatory Nos. 10, 13-15 and Document Request No. 5),

Exhibit G (Petitioner's First Supplemental Responses at same), and Exhibit K (Petitioner's Second Supplemental Responses at same). And although the flaws with the "survey" and "expert" testimony are self-evident, the fact that Petitioner failed to disclose them in discovery is extremely prejudicial to Respondent and should not be considered.

**IV. CONCLUSION**

Therefore, for the foregoing reasons, Petitioner fails to meet the very high burden required to prove that Registrant's BACKRACK Mark has become generic. In contrast, Registrant has provided substantial evidence which confirms the BACKRACK Mark remains a strong trademark associated exclusively with Registrant and its registration maintained. For all of these reasons, Petitioner's Motion should be denied and Respondent's Cross-Motion for Summary Judgment pursuant to Fed. R. Civ. P. 56(c) granted and the cancellation petition should be dismissed with prejudice.

Respectfully submitted,

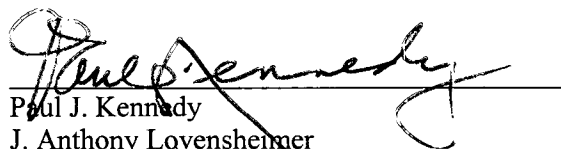

Paul J. Kennedy  
J. Anthony Lovenshimer  
PEPPER HAMILTON LLP  
3000 Two Logan Square  
Eighteenth & Arch Streets  
Philadelphia, PA 19103-2799  
Tel: (215) 981-4000  
Fax: (215) 981-4750

*Attorneys for Registrant  
Backrack, Inc.*

Dated: August 5, 2009



2. I submit this Declaration in support of Registrant's Opposition to Petitioner's Motion for Summary Judgment and in support of Registrant's Cross-Motion for Summary Judgment.

3. Before addressing all of the specific facts at issue in this dispute, I must take this opportunity to affirmatively state for the record that it is my belief that STK has instituted this proceeding simply to attack Backrack because of Backrack's decision to terminate its relationship with the STK affiliated company, Armor Deck. In addition, STK is seeking to destroy Backrack's valuable BACKRACK® trademark for no other reason than to retaliate for Backrack's commencement of a collection lawsuit currently pending in New Jersey state court against Armor Deck. However, despite STK's baseless assertions, all of the facts set forth herein establish that the BACKRACK® brand has become a strong indicator to consumers that Backrack's quality product line, including the headache racks/cab guards and all of the coordinating accessories originate from Backrack. Allowing STK's retaliatory petition to cancel Backrack's trademark would destroy the value and goodwill created by Backrack's efforts since I first started the Backrack company with my father over twenty (20) years ago.

#### **Background**

4. In 1988, my father and I started Backrack to develop and manufacture pickup truck accessories including the headache rack/cab guard that my father designed and for which my father had obtained a patent in the United States. A true and accurate copy of U.S. Patent No. 4,867,497 "Load Supporting Rack For Attachment to Pick-up Truck Box" is attached hereto as Exhibit 1.



5. At the time that my father and I founded Backrack, the only product that we offered for sale was the headache rack/cab guard that my father had developed. We sold the headache rack/cab guard under the trademark at issue in this proceeding, BACKRACK®. The trademark BACKRACK® was conceived by my father in 1988 and has been used continuously by Backrack since that time on what has developed to be a wide variety of pick-up truck accessories, including headache racks, cab guards, light brackets, rear bars, toolbox brackets, and side rails.

6. At the time that we developed and introduced the BACKRACK® headache rack/cab guard during the time period of 1988 through 1989, we were unaware of any manufacturers of headache racks/cab guards who had ever used the term “backrack” in any manner to describe or identify their headache racks/cab guards. Backrack was the first and only company to use the term “backrack” in connection with headache racks/cab guards.

7. Since Backrack’s introduction of the BACKRACK® headache rack/cab guard, I am unaware of any other manufacturers of headache racks/cab guards who use “backrack” as a name for or to describe their headache rack/cab guard or as a name or description for a type of headache rack/cab guard. In fact, Backrack has taken several steps to prevent any such use of the BACKRACK® trademark as described below.

#### **Backrack’s Business**

8. Backrack does not sell its products directly to consumers; instead, Backrack sells its products to distributors who in turn sell either directly to consumers or to smaller retailers or “jobbers” who will then sell directly to consumers.

9. Products bearing the BACKRACK<sup>®</sup> mark have been advertised, offered for sale, and sold throughout the United States since 1989 through catalog and other retail advertising, point of sale advertising at various sales and distribution outlets, and through the Internet.

10. Since Backrack sells its products in the United States through distributors, most of the direct advertising costs have been borne by these distributors. Backrack has no direct knowledge of the total advertising expenditures by all companies advertising the BACKRACK<sup>®</sup> line of products.

11. In the automotive parts industry, distributors typically charge manufacturers of products, like Backrack, to appear in their catalogs. As a result, a significant portion of Backrack's direct advertising costs are the fees that Backrack must pay to appear in its distributors' catalogs, such as those printed by Keystone Automotive ("Keystone") and, through 2007, Petitioner's affiliated company, Armor Deck.

12. In addition to the advertising for BACKRACK<sup>®</sup> products done by distributors, Backrack has spent tens of thousands of dollars to promote BACKRACK<sup>®</sup> products throughout the United States.

#### **Backrack and STK/Armor Deck**

13. From approximately 1994 through 2007, Backrack's primary distributor in the United States was Armor Deck, which was (and continues to be) owned by Steve Setteducatti ("Setteducatti"). Setteducatti is also currently the majority owner of the Petitioner in this matter, STK, LLC ("STK"). Since 2007, STK has become a principal direct competitor with Backrack in the pickup truck headache rack/cab guard market.

14. Petitioner's related company, Armor Deck, sold BACKRACK® products and in doing so, advertised and used the BACKRACK® mark for approximately 13 years without any protest or challenge whatsoever. By doing this, Armor Deck was acknowledging and respecting the significance of the BACKRACK® trademark that its affiliated company, Petitioner STK, now seeks to destroy.

15. Backrack's relationship with STK's affiliated company, Armor Deck, began to crumble after Backrack notified Armor Deck of a pricing change. In a letter dated October 11, 2007, I informed Rick Ackley of Armor Deck ("Ackley") of Backrack's decision to adjust the price structure for BACKRACK® products to reflect the shifting value of the Canadian Dollar vis-à-vis the U.S. Dollar. A true and accurate copy of my letter to Ackley dated October 11, 2007 is attached hereto as Exhibit 2.

16. After I sent this letter to Armor Deck, Armor Deck's affiliated company, STK announced its plan to introduce its two headache racks/cab guards, the PRO RACK and PRO GUARD. STK first introduced these new products at the annual Society of Equipment Manufacturers Association ("SEMA") convention in Las Vegas on or about October 31, 2007. Prior to this, to my knowledge, STK had never manufactured a headache rack/cab guard.

17. Armor Deck began advertising and selling the new line of headache racks/cab guards manufactured by its affiliated company, STK, from the products' first introduction. A true and accurate copy of the email I received dated April 22, 2008 entitled "Two New Truck Racks From STK" is attached hereto as Exhibit 3. Armor Deck and STK were under the same ownership of Setteducatti at the time that STK introduced its new line of headache racks/cab guards and remain so to this day. Prior to STK's introduction of its line of

headache racks/cab guards, Armor Deck had never sold any other brand of headache rack/cab guard while also selling the BACKRACK® brand headache rack/cab guard.

18. Backrack chose to end its relationship with Armor Deck as a result of STK's decision to manufacture its own line of headache racks/cab guards in direct competition with Backrack, which were offered for sale and advertised by STK's affiliated company, Armor Deck.

19. Since terminating the relationship with Armor Deck in late 2007, Backrack has used Keystone as its primary distributor in the United States. BACKRACK® products were first included in Keystone's catalogs in early 2008. In addition to Keystone, Backrack distributes its products in the United States through several smaller, regional distributors.

20. At the end of Backrack's business relationship with STK's affiliated company, Armor Deck, Armor Deck owed Backrack approximately \$168 thousand dollars (over several outstanding invoices). When Armor Deck refused to make payment, Backrack sued Armor Deck in a state court proceeding in New Jersey to recover money owed to it. That matter is set for trial on September 14, 2009.

21. After Backrack initiated the collection suit, Armor Deck's affiliate, Petitioner STK, instituted the present cancellation proceeding to challenge the validity of the BACKRACK® mark.

### STK's Headache Rack/Cab Guard Line

22. Armor Deck advertised the new STK product line through print advertisements and through its website at [www.armordeck.us](http://www.armordeck.us). A true and accurate copy of a faxed copy of an Armor Deck advertisement dated April 9, 2008 is attached hereto as Exhibit 4. In addition, a true and accurate copy of the STK printed advertisement for the STK PRO RACK and PRO GUARD is attached hereto as Exhibit 5. A true and accurate copy of the printout that I made from the website [www.armordeck.us](http://www.armordeck.us) on May 7, 2008 is attached hereto as Exhibit 6. STK does not use the term "backrack" in any variation in the advertisements or on the website advertisement to identify or describe the new STK headache rack/cab guard line. These advertisements refer to the new STK products as "Truck Racks."

23. STK has advertised its line of headache racks/cab guards in print advertisements as well as through its website located at [www.stkusa.com](http://www.stkusa.com). See Exhibit 5. True and accurate copies of STK's advertisements that I discovered and printed from the website [www.stkusa.com](http://www.stkusa.com) on May 14, 2008 are attached hereto as Exhibit 7. In the excerpts from the STK website, the term "backrack" does not appear in any context; instead, the terms used by STK to identify the products are only the brand names PRO RACK and PRO GUARD along with the general categories, "cab racks," "cab guards" and "truck racks." *Id.* Armor Deck, the former distributor of BACKRACK® products is identified at the STK website as one of two "Featured Partners" of STK. *Id.*

24. STK's new line of headache racks/cab guards was also advertised on the third-party website [www.ultimateaccessories.com](http://www.ultimateaccessories.com). A true and accurate copy of the printout I made from the website [www.ultimateaccessories.com](http://www.ultimateaccessories.com) on May 14, 2008 is attached hereto as Exhibit 8. The two STK products appear under the heading "Truck Headache Racks" and are

identified as "Pro Guard Truck Rack" and "Pro Rack Truck Rack." The term "backrack" does not appear in the advertisement in any manner.

25. STK's new line of headache racks/cab guards are virtually identical copies of the BACKRACK® line of headache racks/cab guards.

**Backrack's Advertisements For BACKRACK® Products**

26. From the beginning of Backrack's existence, I have been primarily responsible for the preparation of Backrack's advertisements. In the earliest advertisements, I did everything from drafting the text, taking the photographs of BACKRACK® products and laying out the text and photos in the advertisement. While I am still primarily responsible for drafting the advertisement copy, I now use outside vendors to take photographs and prepare the actual layout for all official Backrack advertisements, including but not limited to printed materials and Backrack's Internet website content.

27. Backrack has advertised its BACKRACK® products through various print advertisements including, but not limited to flyers, pamphlets and printed product guides that are mailed directly to potential customers or provided to distributors of BACKRACK® products to use as point of sale advertisements, to distribute to resellers for their use in connection with the sale of BACKRACK® products, or to provide potential customers with informational materials.

28. One of the earliest forms of advertising that Backrack relied on and continues to rely on to this day is the prominent display of the BACKRACK® brand name in large white font directly on the black headache rack/cab guard and other products (i.e. side rails and rear bar) which, when installed on vehicles, is visible to other vehicles on the road. The prominent display of the BACKRACK® mark on Backrack's products has been a significant

means of promoting BACKRACK® brand products. The installed products effectively serve as moving billboards advertising BACKRACK® products.

29. More recently, Backrack has made and continues to make available to its authorized distributors pre-approved advertising content, photographs and logos via the Internet or as digital files sent directly to distributors for use in advertising BACKRACK® products. This content was first made available to distributors via the Internet in early 2008. Prior to that, Backrack provided content through email or through a CD Rom. By providing this material to our distributors, we hope to create a more uniform presentation of the BACKRACK® brand to potential customers as well as to ensure proper trademark use and marking in such materials.

30. Backrack's distributors may modify the text provided by Backrack to fit within their constraints that may arise when they must fit the pre-approved advertising copy and material into a catalog or other printed/digital advertising material. The ultimate decision maker for any particular advertisement will be the distributor preparing the particular advertisement.

31. Backrack has routinely marked the BACKRACK® mark with a "TM" symbol or otherwise set off the BACKRACK® mark in its promotional materials through a combination of capitalization, font size or style along with use of the images of the products themselves bearing the BACKRACK® mark as installed on vehicles.

32. In addition, Backrack has applied a decal bearing the BACKRACK® mark to all BACKRACK® headache racks/cab guards that it has manufactured since first offering them for sale in 1988. A true and accurate copy of the original decal is attached hereto as Exhibit 9. This decal contains the BACKRACK® logo which incorporates BACKRACK® marked with the "TM" designation. Backrack has chosen only to use the "TM" designation both

in the United States and Canada despite the fact that Backrack owns a trademark registration in the United States as it does not yet have a corresponding trademark registration in Canada.

33. Attached hereto as Exhibit 10 is a true and accurate copy of an advertisement that I prepared for the BACKRACK<sup>®</sup> headache rack/cab guard. This advertisement reflects one of the earliest printed advertisements that I prepared. It was used as a direct mailing piece to potential customers during the early 1990's. This advertisement includes a banner heading at the top center of the advertisement comprised of the BACKRACK<sup>®</sup> logo marked with a "TM", and the title "THE SHAPE OF TODAY'S PICKUP TRUCK RACK" in a much larger font size than the remainder of the advertisement. In addition to the use of the general term "pickup truck rack" in the title, the first paragraph states: "When you visited the SEMA show in November you stopped by and had a look at our product, the BACKRACK<sup>®</sup> pickup truck rack." I also included repeated uses of the BACKRACK<sup>®</sup> mark in various manners to set off the BACKRACK<sup>®</sup> brand from the rest of the advertising text, including in all capital letters, in a bold font, with an initial capital letter, or with a "TM" symbol.

34. Attached hereto as Exhibit 11 is a true and accurate copy of the cover and advertisement for BACKRACK<sup>®</sup> products which appeared in the December 1993 issue of the trade magazine, *Trucking Times*. I was responsible for the text, photos and layout of this advertisement. The mark BACKRACK<sup>®</sup> is presented with a superscript "TM" and either in all capital letters or with an initial capital letter in order to set off the mark from the rest of the text.

35. Attached hereto as Exhibit 12 is a true and accurate copy of an advertisement that I prepared for the BACKRACK<sup>®</sup> headache rack/cab guard in or about 1994. The advertisement was a printed advertisement that Backrack provided to its distributors,



including Armor Deck, to use as a point of sale advertising piece. I was solely responsible for the photos, text and layout of this advertisement. I used the banner heading "BACKRACK™" which appears in larger bold font at the top center of the advertisement along with the statement "Backrack is a Trademark of Backrack, Inc." The BACKRACK® mark is repeatedly used in various manners, including in all capital letters, in a bold font, with an initial capital letter, or with a superscript "TM" symbol to set off the brand name BACKRACK® from the rest of the text. I also used pictures of the BACKRACK® headache rack/cab guard to show the consumers exactly what kind of product Backrack was selling at the time, which is identified in the text accompanying the photographs as "the rack" and also contrasted to a "full frame rack" and "over the cab racks."

36. Attached hereto as Exhibit 13 is a true and accurate copy of an advertisement that I prepared for the BACKRACK® headache rack/cab guard specifically for use by General Motors Canada in or about 1992/1993. The advertisement is a printed advertisement that Backrack provided exclusively to General Motors Canada to use as a point of sale advertising piece. I was solely responsible for the photos, text and layout of this advertisement. I used the banner heading "BACKRACK™" which appears in a significantly larger bold font at the top center of the advertisement along with repeated uses of the BACKRACK® mark in all capital letters with a superscript "TM" symbol in this advertisement to set off the brand name BACKRACK® from the rest of the text. I also used pictures of the BACKRACK® headache rack/cab guard to show the consumers exactly what kind of products Backrack was selling at the time.

37. Attached hereto as Exhibit 14 is a true and accurate copy of an advertisement that I prepared for the BACKRACK® headache rack/cab guard in or about 1994.

The advertisement was a three-fold brochure that Backrack provided to its distributors, including Armor Deck, to use as a point of sale advertising piece and to provide to resellers as well as to potential customers. I was solely responsible for text and layout of this advertisement along with four of the six photographs. The front cover for the brochure is depicted on the far right third of the first page of this exhibit. The cover includes the BACKRACK<sup>®</sup> trademark on the top center portion in a significantly larger font directly above the words "Pickup Track Rack" and the BACKRACK<sup>®</sup> logo along with the statement "Mount Lights On A Rack That Looks As Good As It Works." The pamphlet also includes photographs of pickup truck headache racks and other pickup truck accessories bearing the BACKRACK<sup>®</sup> mark together with the statement "Backrack is a Trademark of Backrack Inc." The BACKRACK<sup>®</sup> mark is repeatedly used in various manners, including in all capital letters, in a bold font, with an initial capital letter, or with the superscript "TM". These uses of BACKRACK<sup>®</sup> set off the brand name BACKRACK<sup>®</sup> from the rest of the text. I also used pictures of the BACKRACK<sup>®</sup> headache rack/cab guard to show the consumers exactly what kinds of product Backrack was selling. In the text accompanying the photos, the BACKRACK<sup>®</sup> headache rack/cab guard depicted is explicitly contrasted to a "full frame rack."

38. The advertisement depicted in Exhibit 14 also reflects the design change that Backrack was required to make by law: clear the area where the rear brake light was now required to be placed on pickup trucks. As a result, all BACKRACK<sup>®</sup> headache racks/cab guards have since split the BACKRACK<sup>®</sup> mark into two portions in order to provide the legally-mandated space for the brake light.

39. Attached hereto as Exhibit 15 is a true and accurate copy of an advertisement that I prepared for the BACKRACK<sup>®</sup> headache rack/cab guard in or about 1994.

The advertisement was a three-fold brochure that Backrack provided to its distributors, including Armor Deck, to use as a point of sale advertising piece and to provide to jobbers as well as to potential customers . I created the text and layout of this advertisement along with four of the six photographs. The front cover for the brochure is depicted on the far right third of the first page of this exhibit. The cover includes the BACKRACK<sup>®</sup> trademark on the top center portion in a significantly larger font directly above the words "Pickup Track Rack" along with a photo of the BACKRACK<sup>®</sup> headache rack/cab guard. The cover also includes the statement "Mount Lights On A Rack That Looks As Good As It Works." The pamphlet also includes photographs of pickup truck headache racks and other pickup truck accessories bearing the BACKRACK<sup>®</sup> mark and the statement "Backrack is a Trademark of Backrack Inc." The BACKRACK<sup>®</sup> mark is repeatedly used in various manners, including all capital letters, in a bold font, and with an initial capital letter. These uses of BACKRACK<sup>®</sup> set off the brand name BACKRACK<sup>®</sup> from the rest of the text. I also used pictures of the BACKRACK<sup>®</sup> headache rack/cab guard to show the consumers exactly what kind of product Backrack was selling, which is explicitly contrasted to a "fullsize or custom racks" in the text accompanying the photographs.

40. Attached hereto as Exhibit 16 is a true and accurate copy of the cover and advertisement for BACKRACK<sup>®</sup> products which appeared in the 1996 Buyer's Guide Issue of the trade magazine, *Trailer Body Builders*. I was responsible for the text, photos and layout of this advertisement. The mark BACKRACK<sup>®</sup> is presented with all capital letters or with an initial capital letter in order to set off the mark from the rest of the text. The advertisement appeared on the same page as the listing for Backrack, which was under the category "Cab Protectors."

41. Attached hereto as Exhibit 17 is a true and accurate copy of an advertisement that I prepared for the BACKRACK<sup>®</sup> headache rack/cab guard in or about

2000/2001. The advertisement was a two-sided Applications Chart that was provided to resellers for use as a point of sale advertising piece and to allow resellers and customers to determine the specific part number to order. I created the text and layout of this advertisement, but the photographs were prepared by a professional photographer. This advertisement includes a banner heading in which the BACKRACK<sup>®</sup> trademark appears in a significantly larger font directly above a photograph of the BACKRACK<sup>®</sup> headache rack/cab guard installed on a pickup truck along with photographs of other pickup truck accessories. I used the BACKRACK<sup>®</sup> mark in various manners, including, but not limited to in all capital letters, in a bold font, or with an initial capital letter in order to set off the BACKRACK<sup>®</sup> mark from the remainder of the text. In addition, I also used a picture of the BACKRACK<sup>®</sup> headache rack/cab guard installed in a pickup truck to show the consumers exactly what kind of product Backrack was selling at the time, which is explicitly contrasted to a "full frame rack" in the text accompanying the photograph. The BACKRACK<sup>®</sup> headache rack/cab guard is also explicitly equated to a "cab guard" in the text as well: "the Backrack offers the versatility you expect from a cab guard."

42. Attached hereto as Exhibit 18 is a true and accurate copy of an advertisement that I prepared for the BACKRACK<sup>®</sup> headache rack/cab guard. The advertisement was a three-fold brochure that Backrack provided to its distributors, including Armor Deck, to use as a point of sale advertising piece and to provide to jobbers as well as to potential customers. I created the text and layout of this advertisement and used the same professional photographs used in Exhibit 17. The front cover for the brochure is depicted on the far right third of the first page of this exhibit. The cover includes the BACKRACK<sup>®</sup> trademark along the left margin of the cover in a significantly larger font than the rest of the text and directly above a photograph of the BACKRACK<sup>®</sup> headache rack/cab guard installed on a pickup

truck. The pamphlet also includes photographs of pickup truck headache racks and other pickup truck accessories bearing the BACKRACK<sup>®</sup> mark and the statement “Backrack is a Trademark of Backrack Inc.” The BACKRACK<sup>®</sup> mark is repeatedly used in various manners, including all capital letters, a bold font, an oversized font, or with an initial capital letter. These uses of BACKRACK<sup>®</sup> set off the brand name BACKRACK<sup>®</sup> from the rest of the text.

43. Attached hereto as Exhibit 19 is a true and accurate copy of an advertisement that I prepared for the BACKRACK<sup>®</sup> headache rack/cab guard in or about 2004. The advertisement was a three-fold brochure that Backrack provided to its distributors, including Armor Deck, to use as a point of sale advertising piece and to provide to jobbers as well as to potential customers. Also, it was also intended to be used as a mailer to potential customers as well. I created the text of this advertisement and used professional photographs taken by a third party. The front cover for the brochure is depicted on the far left half of the first page of this exhibit. The cover includes the BACKRACK<sup>®</sup> trademark on the left margin of the cover in a significantly larger font than the rest of the text and marked with the superscript “TM” directly alongside photographs of the BACKRACK<sup>®</sup> headache rack/cab guard installed on pickup trucks. The pamphlet also includes photographs of pickup truck headache racks and other pickup truck accessories bearing the BACKRACK<sup>®</sup> mark and repeated uses of the BACKRACK<sup>®</sup> mark along with repeated uses of the BACKRACK<sup>®</sup> mark in all capital letters in conjunction with the “TM” designation. These uses of BACKRACK<sup>®</sup> set off the brand name BACKRACK<sup>®</sup> from the rest of the text. In addition, I also used the pictures of the BACKRACK<sup>®</sup> headache rack/cab guard installed in a pickup truck to show the consumers exactly what kind of product Backrack was selling at the time, which I explicitly referred to as a “rack”: “Each rack is custom designed ...”

44. Attached hereto as Exhibit 20 is a true and accurate copy of an advertisement for the BACKRACK<sup>®</sup> headache rack/cab guard that was created in or about 2007. This advertisement is the current version of Backrack's advertising for its two types of headache rack/cab guards. The advertisement is a three-fold brochure that Backrack provides to its distributors to use as a point of sale advertising piece and to provide to jobbers as well as to potential customers. It was also intended to be used as a mailer to potential customers as well. This advertisement is also made available to distributors of BACKRACK<sup>®</sup> products through Backrack's Internet based advertising materials. I created the text of this advertisement, but the actual layout of the advertisement was prepared by the company Adverdia. The front cover for the brochure is depicted on the far right third of the first page of this exhibit. The cover includes the BACKRACK<sup>®</sup> trademark on the top center of the cover in a black background and in a significantly larger font than the rest of the text. The BACKRACK<sup>®</sup> mark is marked with the superscript "TM". The heading appears directly above a new photograph of the BACKRACK<sup>®</sup> headache rack/cab guard along with BACKRACK<sup>®</sup> side rails as installed on pickup trucks. The pamphlet also includes photographs of pickup truck headache racks and other pickup truck accessories bearing the BACKRACK<sup>®</sup> mark and the statement "Backrack is a Trademark of Backrack Inc." The BACKRACK<sup>®</sup> mark is repeatedly used in all capital letters. These uses of BACKRACK<sup>®</sup> set off the brand name BACKRACK<sup>®</sup> from the rest of the text.

45. Attached hereto as Exhibit 21 is a true and accurate copy of an advertisement for the BACKRACK<sup>®</sup> side rails that was created in or about 2007. This advertisement is the current version of Backrack's advertising for the side rails that Backrack sells in conjunction with the BACKRACK<sup>®</sup> headache racks/cab guards. The advertisement is a three-fold brochure that Backrack provides to its distributors to use as a point of sale advertising

piece and to provide to jobbers as well as to potential customers. It was also intended to be used as a mailer to potential customers as well. This advertisement is also made available to distributors of BACKRACK<sup>®</sup> products through Backrack's Internet based advertising materials. I created the text of this advertisement, but the actual layout of the advertisement was prepared by the company Adverdia. The front cover for the brochure is depicted on the far right third of the first page of this exhibit. The cover includes the BACKRACK<sup>®</sup> trademark on the top center of the cover in a black background and in a significantly larger font than the rest of the text. The BACKRACK<sup>®</sup> mark is marked with the superscript "TM". The heading appears directly above a new photograph of the BACKRACK<sup>®</sup> headache rack/cab guard along with BACKRACK<sup>®</sup> side rails as installed on pickup trucks. The pamphlet also includes photographs of pickup truck headache racks and other pickup truck accessories bearing the BACKRACK<sup>®</sup> mark and the statement "Backrack is a Trademark of Backrack Inc." The BACKRACK<sup>®</sup> mark is repeatedly used in all capital letters. These uses of BACKRACK<sup>®</sup> set off the brand name BACKRACK<sup>®</sup> from the rest of the text.

46. Attached hereto as Exhibit 22 is a true and accurate copy of the Backrack Product Guide that was created in or about 2007. This advertisement reflects the current version of Backrack's advertising for BACKRACK<sup>®</sup> products. Backrack provides the Product Guide to its distributors to use as a point of sale advertising piece and a reference piece for distributors, resellers and customers which is designed to be placed in a three-ring binder and used at the stores or dealerships where BACKRACK<sup>®</sup> products are sold. This advertisement is also made available to distributors of BACKRACK<sup>®</sup> products through Backrack's Internet based advertising materials. I created the text of this advertisement, but the actual layout of the advertisement was prepared by Adverdia. The front cover for the Product Guide includes the

BACKRACK<sup>®</sup> trademark, marked with the superscript “TM”, on the top center of the cover set in a black background and in a significantly larger font than the rest of the text. The heading appears directly above a photograph of the BACKRACK<sup>®</sup> headache rack/cab guard and BACKRACK<sup>®</sup> side rails as installed on a pickup truck. The Product Guide includes photographs of pickup truck headache racks and other pickup truck accessories bearing the BACKRACK<sup>®</sup> mark and the statement “Backrack is a Trademark of Backrack Inc.” The BACKRACK<sup>®</sup> mark is repeatedly used in all capital letters. These uses of BACKRACK<sup>®</sup> set off the brand name BACKRACK<sup>®</sup> from the rest of the text.

47. Attached hereto as Exhibit 23 are true and accurate copies of Backrack’s prior generation of Product Guide and Application Guide which was used from approximately 2004 through the introduction of the current version in late 2007. Backrack consistently used the “TM” designation in connection with the BACKRACK<sup>®</sup> mark throughout these documents. Moreover, the BACKRACK<sup>®</sup> mark was used in connection with the full line of BACKRACK<sup>®</sup> products, including the headache racks/cab guards, the side rails, rear bar, light brackets, tool box brackets, and other related accessories.

48. Attached hereto as Exhibit 24 are true and correct copies of templates for advertisements that Backrack has made available to its distributors and resellers through its Internet-based advertising materials and through direct emails to select distributors. The current advertising templates, including the photos and text comprising them, are made available to distributors of BACKRACK<sup>®</sup> products through a special section of the Backrack website which requires the distributors to register and receive a password to access the material. Backrack first implemented this system in early 2008. Prior to that, Backrack made advertising materials



available to its distributors by sending digital copies of photographs and text directly to distributors through email and through delivery of a CD Rom.

49. The advertisements set forth at Exhibit 24 are the recommended templates for all advertising of BACKRACK<sup>®</sup> products. However, as discussed above, the distributors may make adjustments or modifications to the content or layout of the material in order to make the template fit within their advertising parameters.

50. Attached hereto as Exhibit 25 is a true and correct copy of a point of sale advertisement that Backrack has made available to its distributors and resellers through its Internet-based advertising materials and through direct emails to select distributors.

51. Backrack has also advertised and promoted BACKRACK<sup>®</sup> products through numerous Internet websites, including but not limited to those Internet websites owned and operated by Backrack: [www.backrack.com](http://www.backrack.com); [www.backrack.ca](http://www.backrack.ca); [www.backrack.org](http://www.backrack.org); [www.backrack.info](http://www.backrack.info); [www.backrack.biz](http://www.backrack.biz); [www.backrack.us](http://www.backrack.us); [www.backrack4trucks.com](http://www.backrack4trucks.com); [www.backrack.cc](http://www.backrack.cc); [www.backrack.bz](http://www.backrack.bz); [www.backrack.us.com](http://www.backrack.us.com); [www.backrack.mobi](http://www.backrack.mobi); [www.backrack.tv](http://www.backrack.tv); and [www.backrack.de](http://www.backrack.de). Backrack maintains at least 13 different domain name registrations that include the BACKRACK<sup>®</sup> mark to ensure that they are not registered to others.

52. Backrack has recovered domain name registrations from third parties that include the mark BACKRACK<sup>®</sup>, including a registration originally obtained by Richard Ackley of Armor Deck, a business associate of STK, LLC, and now redirects these domains to its own website, [www.backrack.ca](http://www.backrack.ca). True and accurate copies of the WHOIS reports for Backrack's domain names printed by me or at my direction on October 28, 2008 from <http://whoisdomaintools.com> are attached hereto collectively as Exhibit 26.

**Armor Deck's Advertisement of BACKRACK® Headache Racks/Cab Guards**

53. Armor Deck continued to advertise and sell its existing stock of BACKRACK® products, including the BACKRACK® headache rack/cab guard, along with the new STK truck racks. A true and accurate copy of the print outs made by me or at my direction from the website [www.armordeck.us](http://www.armordeck.us) on May 14, 2008 are attached hereto as Exhibit 27.

54. The Armor Deck website identifies "a list of our Contractor-Industrial categories" of products that it sells. *Id.* The Contractor-Industrial category is the category within which both Backrack's and STK's lines of headache racks/cab guards are found.

55. Armor Deck uses the general category name of "cab guards" to identify this category. *Id.* The BACKRACK® brand is used by Armor Deck to identify the source of the items listed under the heading "BACKRACK™", including the "Backrack™ Truck Racks and Cab Guards," "Light Bar Brackets," "Safety Rack™" and "Tool Box Brackets." *Id.*

**Third-Party Advertising For BACKRACK® Products**

56. BACKRACK® products are also advertised at numerous third-party websites, including but not limited to the following: [www.drawtite.com](http://www.drawtite.com); [www.americanvan.com](http://www.americanvan.com); [www.awdirect.com/cab-protection/](http://www.awdirect.com/cab-protection/); [www.eautoworks.com](http://www.eautoworks.com); [www.fullertruck.com](http://www.fullertruck.com); [www.anythingtruck.com](http://www.anythingtruck.com); [www.pickupspecialties.com](http://www.pickupspecialties.com); [www.streetsideauto.com](http://www.streetsideauto.com); [www.rackwarehouse.com](http://www.rackwarehouse.com); [www.truckaddons.com](http://www.truckaddons.com); [www.truckchamp.com](http://www.truckchamp.com); [www.westernperformance.com](http://www.westernperformance.com).

57. A true and accurate copy of the printout from [www.usworkvan.com](http://www.usworkvan.com) made by me or at my direction on May 14, 2008 is attached hereto as Exhibit 28. In this advertisement, the BACKRACK<sup>®</sup> headache rack/cab guard is pictured and appears under the general category “Cab Guards.”

58. A true and accurate copy of the printout from [www.mutualwheelco.com](http://www.mutualwheelco.com) made by me or at my direction on May 14, 2008 is attached hereto as Exhibit 29. In this advertisement, the BACKRACK<sup>®</sup> headache rack/cab guard is pictured and appears under the heading “BackRack Cab Guards.” In addition, the text refers to the product as the “BackRack cab guards” and “these cab guards.”

59. A true and accurate copy of the printout from [www.anythingtruck.com](http://www.anythingtruck.com) made by me or at my direction on May 14, 2008 is attached hereto as Exhibit 30. In this advertisement, the BACKRACK<sup>®</sup> headache rack/cab guard is pictured and appears under the heading “BACKRACK Cab Guards.” In addition, the text refers to the product as the “BackRack cab guards” and includes a section entitled “10 Reasons to Choose BACKRACK Cab Guards.” The advertisement appeared in the section of the website entitled “Truck Racks – BackRack Cab Guards.”

60. A true and accurate copy of the printout from [www.4wheelonline.com](http://www.4wheelonline.com) made by me or at my direction on May 14, 2008 is attached hereto as Exhibit 31. In this advertisement, the BACKRACK<sup>®</sup> headache rack/cab guard is pictured along with other BACKRACK<sup>®</sup> products and appears under the heading “BackRack Headache Racks.” In addition, the website includes a section at the bottom of the page which is entitled “Truck Headache Racks – Quick Find Guide.” The BACKRACK<sup>®</sup> headache racks/cab guards are listed

under this heading along with headache racks/cab guards manufactured by Tough Country. The Tough Country products are identified as “Touh Country Headache Racks” (sic.), “Touh Country Louvered Headache Racks” (sic.), Touh Country Heavy Duty Headache Racks” (sic.), and “Touh Country Headache Rack Accessories” (sic.).

61. A true and accurate copy of the printout from [www.truckchamp.com](http://www.truckchamp.com) made by me or at my direction on May 14, 2008 is attached hereto as Exhibit 32. In this advertisement, the BACKRACK<sup>®</sup> headache rack/cab guard is pictured and appears under the heading “HEADACHE RACK.” In addition, the text refers to the product as the “BACKRACK<sup>™</sup> Headache Rack.” In addition, the website includes a list of categories on the left side of the page which includes the category “Headache Racks,” but does not include BACKRACK<sup>®</sup> as a category. The website also provides a section entitled “Truck Champ’s Headache Rack Learning Center” in which the BACKRACK<sup>®</sup> headache rack/cab guard is referred to as the “BACKRACK<sup>™</sup> Headache Rack.” The guide also touts the quality of the headache racks/cab guards emanating from Backrack: “we offer only the highest grade Racks – from BACKRACK – and at reasonable prices.”

62. A true and accurate copy of the printout from [www.pickupspecialties.com](http://www.pickupspecialties.com) made by me or at my direction on May 14, 2008 is attached hereto as Exhibit 33. In this advertisement, the BACKRACK<sup>®</sup> headache rack/cab guard is pictured and appears directly beneath the heading “BACKRACK<sup>™</sup> Function and Style for Today’s Trucks.” In addition, the heading for the entire section is entitled “BACKRACK HEADACHE RACK FOR TRUCKS.” In addition, the website includes a list of categories on the left side of the page which includes the categories “Cab Guards” and “Headache Racks,” but does not include BACKRACK<sup>®</sup> as a

category. The page also includes links to the “BackRack Rear Bar,” “BackRack Safety Lights,” “BackRack Safety Rack,” and “Optional BackRack Accessories.”

63. A true and accurate copy of the printout from [www.cargogear.com](http://www.cargogear.com) made by me or at my direction on May 14, 2008 is attached hereto as Exhibit 34. In this advertisement, the BACKRACK<sup>®</sup> headache rack/cab guard is pictured and appears directly beneath the heading “BackRack<sup>™</sup> Headache Rack.” In addition, the heading for the entire section is entitled “BackRack Truck Racks Headache racks, safety racks, and BackRack<sup>™</sup> accessories.” In addition, the website includes a list of categories on the left side of the page which includes the category “Truck Racks,” but does not include BACKRACK<sup>®</sup> as a category. The page also includes advertisements of the BACKRACK<sup>®</sup> products identified as “BackRack<sup>™</sup> Safety Rack,” BackRack<sup>™</sup> Toolbox Brackets,” and “BackRack<sup>™</sup> Accessory Brackets.”

64. A true and accurate copy of the printout from [www.rackwarehouse.com](http://www.rackwarehouse.com) made by me or at my direction on May 14, 2008 is attached hereto as Exhibit 35. In this advertisement, the BACKRACK<sup>®</sup> headache rack/cab guard is pictured and appears directly above the descriptions “BackRack Window Guard Headache Rack” and “BackRack Window Guard with Toolbox Mounting Kit.” The heading for this portion of the website is “BackRack Cab Protector.” In addition, this website includes a list along the left side of the page entitled “Featured Brands.” One of the “Featured Brands” listed under the subcategory “Utility Racks” is “BackRack Cab Protector.” The page also includes advertisements of the BACKRACK<sup>®</sup> products identified as “BackRack Safety Rack Window/Cab Guard,” “BackRack Center Mounted Safety Light Brackets,” “BackRack Center Mounted Safety Light Brackets,” “BackRack Corner Mounted Safety Light Brackets,” and “BackRack Antenna Mounting Bracket.”

65. A true and accurate copy of the printout from [www.ok4wd.com](http://www.ok4wd.com) made by me or at my direction on May 14, 2008 is attached hereto as Exhibit 36. In this advertisement, the BACKRACK® headache rack/cab guard is pictured and appears beneath the heading “Backrack Headache Rack” and the BACKRACK® logo. In addition, the text refers to the “Backrack headache rack for pickup trucks.” The advertisement was discovered by following the categories listed directly above the advertisement, namely “Categories > Truck Bed Accessories > Vendors > Backrack > Headache Racks.”

66. A true and accurate copy of the printout from [www.quadratec.com](http://www.quadratec.com) made by me or at my direction on May 14, 2008 is attached hereto as Exhibit 37. In this advertisement, the BACKRACK® headache rack/cab guard is pictured and appears alongside the heading “BACKRACK Headache Rack.” In addition, the text refers to the BACKRACK® headache rack/cab guard as the “BACKRACK™” after the initial reference to the “BACKRACK Headache Rack.”

67. A true and accurate copy of the printout from [www.etrucktoys.com](http://www.etrucktoys.com) made by me or at my direction on May 14, 2008 is attached hereto as Exhibit 38. In this advertisement, the BACKRACK® headache rack/cab guard is pictured and appears under the BACKRACK® stylized logo. The advertisement also includes the overall heading “Backrack Truck Rack.” In addition, the text describes the product as the BACKRACK® headache rack/cab guard as the “BackRack truck rack.” This advertisement was also accessed by following the links identified above the advertisement, namely “Top > By Manufacturer > Backrack > Backrack Truck Rack.”

68. BACKRACK<sup>®</sup> products are also distributed in the United States by Meyer Distributing. A true and accurate copy of the printout taken from the Meyer Distributing website, [www.meyerdistributing.com](http://www.meyerdistributing.com) made by me or at my direction on May 14, 2008 is attached hereto as Exhibit 39. The printout is the Meyer Distributing "Line Sheet" which essentially lists the manufacturers that Meyer Distributing carries along with a brief description of each manufacturers' products. Backrack is listed in the "Manufacturer" column and the products associated with Backrack are identified as "MULTI-PURPOSE HEADACHE RACKS." The other manufacturers that are listed with "headache racks" are Cross Tread and Go Industries. The term "backrack" in any variation does not appear in the product descriptions set forth under the column entitled "PRODUCTS."

69. In addition to Cross Tread and Go Industries, numerous other manufacturers make products that they identify as "cab guard," "cab rack," or "cab protector." Attached hereto as Exhibit 40 are printouts from various websites made by me or at my direction on May 14, 2008 which identify and demonstrate those manufacturers and their products. None of the manufacturers identified in this exhibit use the term "backrack" in any variation whatsoever.

70. Backrack has consistently been an exhibitor at the annual SEMA show in Las Vegas. A true and accurate copy of a printout of the relevant portion of the 2008 SEMA Exhibitor List and the Exhibitor Information for Backrack made by me or at my direction from the SEMA website at <http://sema.experient-inc.com> is attached hereto as Exhibit 41. The products identified under the heading "Exhibiting Products" for Backrack are "Truck Bed Rail Caps/Truck Bed Rail Bars, Racks/Carriers, Truck Bed Accessories, Headache Racks, and Truck Bed Rails."

### **Backrack's Trademark Enforcement Efforts**

71. Backrack, through its legal counsel, monitors the Internet to identify any potentially confusing or improper use of the mark BACKRACK® and routinely monitors the US and Canadian trademark registers to identify any pending applications that are potentially confusing with its BACKRACK® trademark and opposes such applications when deemed prudent.

72. Backrack has caused numerous third parties to cease using the BACKRACK® mark in potentially damaging ways. Attached hereto as Exhibit 42 are communications commencing on July 20, 2006 between legal counsel for Backrack in Canada, Michele Ballagh ("Ballagh"), and AWATEC Industries Inc. concerning AWATEC's unauthorized use of BACKRACK® in connection with headache racks. AWATEC ceased unauthorized use without commencement of legal proceedings.

73. Attached hereto as Exhibit 43 are communications commencing on May 21, 2008 between Ballagh and Westcan Manufacturing LTD. concerning Westcan's improper use of the BACKRACK® mark in connection with headache racks along with a copy of the advertisement that appeared at [www.westcanmanufacturing.com](http://www.westcanmanufacturing.com) that caused Backrack to pursue Westcan. The matter resolved after cease and desist letter, by way of a written undertaking between the parties whereby Westcan agreed to remove the improper uses. A true and accurate copy of the Undertaking is attached hereto as Exhibit 44.

74. In addition, on January 22, 2008 I sent an email on behalf of Backrack to the website [www.bigboyscustomtoys.com](http://www.bigboyscustomtoys.com) to demand that the website cease use of "Back Rack" in the advertising for the STK PRO RACK and PRO GUARD headache racks/cab guards. A



true and accurate copy of the email correspondence relating to this demand is attached hereto as Exhibit 45. The matter resolved by the website agreeing to remove the use of "Back Rack" or "BACKRACK" from the website when not used in reference to Backrack and its products.

75. Most recently, on July 7, 2009 my counsel in Canada, Michele Ballagh, sent an email on behalf of Backrack to the website [www.buyautotruckaccessories.com](http://www.buyautotruckaccessories.com) to demand that the website cease use of "Back Rack" as the name of a subcategory of "Truck Cab Protection" described as "Cab Guards and Back Racks." A true and accurate copy of the email correspondence relating to this demand is attached hereto as Exhibit 46. To date, the operators of this website have failed or refused to respond and further legal action is contemplated. It is my understanding that the Petitioner has stated that it has a confidential business relationship with this entity. In fact, both BuyAutoTruckAccessories.com as well as BigBoysCustomToys.com are listed on the STK website as "FEATURED AUTOMOTIVE RELATED LINKS." Therefore, I am not surprised that the only apparent and sustained misuse of the BACKRACK<sup>®</sup> trademark originates from companies that are closely linked to the Petitioner, STK.

76. Backrack, through its legal counsel, has also sent several notices to website operators and servers to demand the removal of potentially harmful content posted on a variety of websites and blogs. True and accurate copies of the communications related to these efforts are attached hereto as Exhibit 47. The content challenged by Backrack was subsequently removed in four of the six instances. I have reason to believe that the two remaining instances may have been posted by the Petitioner itself or at its request. In this regard, I note that these two blog entries include hyperlinks to the website of a party who sells the STK PRO RACK and

PRO GUARD headache racks/cab guards and with whom the Petitioner has admitted to having a confidential business relationship, namely BuyAutoTruckAccessories.com. *See Id.*

77. Backrack has also instituted a trademark opposition proceeding in Canada against the applicant Chia-Chen Shih for the trademark application filed to register BUZZ RACK & Design for use in association with various truck racks and accessories. True and accurate copies of the documents relating to this proceeding are attached hereto at Exhibit 48. The application was subsequently abandoned by the applicant.

### **Third Party Use of the Term Backrack**

78. The only third-party use of the term "backrack" of which I have become aware are the following: Bogdan M. Luklinski, owner of BACKRACK (U.S. trademark Registration No. 3,285,848) for Orthopedic supports; the R. Lieberman Co., which uses the trade name BACK RACK in the manufacturing of rear-mounted vehicle sport racks (*e.g.* bike racks and snow board racks); Marathon Seat Covers, Inc., applicant for BACKRACK (U.S. trademark application Serial No. 78/015866 (abandoned)) for Vehicle racks for guns and fishing rods; and Bontrager, user of BACK RACK as a product name for a rear-mounted rack on bicycles used to transport or to carry items. Attached hereto as Exhibit 49 are true and correct copies of printouts made at my direction on May 14, 2008 from various websites demonstrating some of these third parties.

79. Backrack has taken no action against these entities because none of these uses is in connection with pickup truck accessories or any other goods that are even remotely related to the goods sold by Backrack.

### Current Examples of BACKRACK in Third Party Publications

80. Attached hereto as Exhibit 50 are true and accurate excerpts from the print out that was made at my direction on October 8, 2008 from the website [www.truckingtimes.com](http://www.truckingtimes.com) which identifies the manufacturers, suppliers and distributors that are carried at [www.truckingtimes.com](http://www.truckingtimes.com). In this comprehensive listing, Backrack is listed as a "manufacturer". *Id.* The entry also indicates the following "Categories this company is in:" "Bed Rails;" "Cab Back Protectors, Exterior;" "Cargo Anchoring Systems;" "Headache Racks;" and "Ladder-Contractor-Utility Racks and Accessories." *Id.* BACKRACK® does not appear in this printout anywhere under the heading "Categories this company is in;" instead, the only reference is to the name of the company Backrack as a source for the categories of products listed above.

81. BACKRACK® products were first included in the Keystone 2008 Specialty Catalog ("Keystone Catalog"), a true and accurate copy of which is attached hereto as Exhibit 51. In addition to being featured in the Keystone Catalog in the "New Products & Lines" section, the BACKRACK® products appeared in the section entitled "Exterior Accessories Bed Protection." This section of the Keystone Catalog included other headache racks manufactured by companies other than Backrack. In the Product Index to the Keystone Catalog, there is no listing for "BACKRACK®" as a "Product," but there are listings for "Cab Guards," "Headache Racks," and "Truck Racks." *Id.* at BR00184. The pages identified under these headings in the index correspond to the pages on which the BACKRACK® products, including its headache racks/cab guards, and those of other manufacturers appear.

82. BACKRACK® products are advertised in the Keystone's monthly product advertisements along with other printed catalogs. Attached hereto as Exhibit 52 are true and

accurate copies of advertisements from various Keystone advertisements and an advertisement from Arrow Speed "Insider" from 2008 in which BACKRACK<sup>®</sup> products were advertised.

83. In all of the examples of Backrack's past and present advertising, it is clear that the BACKRACK<sup>®</sup> trademark designates the source of the products sold by Backrack rather than a general term used to identify a category of pickup truck headache racks/cab guards and accessories.

84. After approximately 20 years of extensive advertising and development, the BACKRACK<sup>®</sup> trademark is the indicator of the source of quality pickup truck accessories originating from Backrack. Backrack's competitors have not adopted the term "backrack" in any combination, nor have the distributors of pickup truck accessories identified any general category of pickup truck headache rack/cab guard as the "backrack" type of headache rack/cab guard. Instead, those in the industry consistently use the generic terms "headache rack," "cab guard," or "truck rack" to describe the general type of product involved.

85. It is my belief that STK, through its majority owner, Setteducatti, has instituted this proceeding as a way of attacking Backrack for its decision to terminate its relationship with the Setteducatti-owned affiliate of STK, Armor Deck, and in retaliation for Backrack's collection suit currently pending against Armor Deck. While I may not have been aware of all of the rules of trademark law that STK now tries to invoke against Backrack, I do

know that the BACKRACK® brand has become a strong indicator of Backrack's quality product line, including the headache racks/cab guards and all of the coordinating accessories. Allowing STK's petition to cancel Backrack's trademark will undermine and destroy the value and goodwill created by Backrack's efforts over those twenty (20) years.

86. I declare that all facts and allegations contained in this Declaration are true to the best of my own knowledge; that all statements made herein of my own knowledge are true and that all statements made on information and belief are believed to be true; and further that these statements were made with the knowledge that willful false statements and the like so made are punishable by fine or imprisonment, or both, under Section 1001 of Title 18 of the United States Code and that such willful false statements may jeopardize the validity of this Declaration.

Dated: July 29, 2009

  
ADRIAN JAYNE

TTAB – STK, LLC v. BACKRACK, INC.  
Cancellation No. 92049332 – Registration No. 3014986

# **EXHIBIT 1**

**United States Patent** [19]  
**Jayne**

[11] Patent Number: **4,867,497**  
 [45] Date of Patent: **Sep. 19, 1989**

- [54] **LOAD SUPPORTING RACK FOR ATTACHMENT TO PICK-UP TRUCK BOX**  
 [76] Inventor: **Gilbert Jayne, R.R. #3, Campbellville, Ontario, Canada, L0P 1B0**  
 [21] Appl. No.: **198,523**  
 [22] Filed: **May 26, 1988**  
 [51] Int. Cl.<sup>4</sup> ..... **B60P 3/00**  
 [52] U.S. Cl. .... **296/3; 224/42.45 R**  
 [58] Field of Search ..... **296/3, 50, 146, 95.1; 211/182; 224/42.42, 42.45 R; 280/756**

- 4,611,824 9/1986 McIntosh ..... 296/3 X  
 4,659,131 4/1987 Flournoy et al. .... 296/3  
 4,752,097 6/1988 Van Kirt et al. .... 296/39.2  
 4,770,458 9/1988 Burke et al. .... 296/3

*Primary Examiner—Dennis H. Pedder*  
*Assistant Examiner—Joseph D. Pape*  
*Attorney, Agent, or Firm—Rogers & Scott*

[57] **ABSTRACT**

A rack has a lower longitudinal truss which in use rests on an upright panel defining a forward part of the box of a pickup truck. A pair of upstanding members connect the lower truss to an upper truss which is parallel to the lower truss and spaced to elevate a load above the cab roof. The upstanding members are inwardly spaced from the ends of the lower truss and the ends of the upper truss are flush with the upstanding members so that a load will be centered in the truck box. A window guard is provided between the upper and lower trusses and is made of flat bar oriented so as to maximize visibility through the rear window of the cab.

[56] **References Cited**

**U.S. PATENT DOCUMENTS**

- 3,765,713 10/1973 Suitt ..... 296/3  
 3,891,262 6/1975 Brunel ..... 296/3  
 4,199,186 4/1980 Faverino ..... 296/50  
 4,389,067 6/1983 Rubio ..... 296/50  
 4,398,763 8/1983 Louw ..... 296/3  
 4,405,170 9/1983 Raya ..... 296/3 X  
 4,565,402 1/1986 Hopkins ..... 296/3  
 4,604,013 8/1986 Elwell et al. .... 296/41 X

**4 Claims, 2 Drawing Sheets**

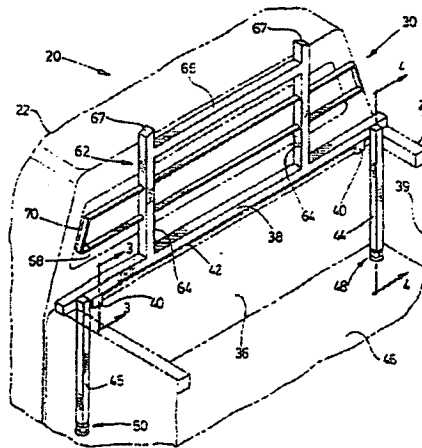





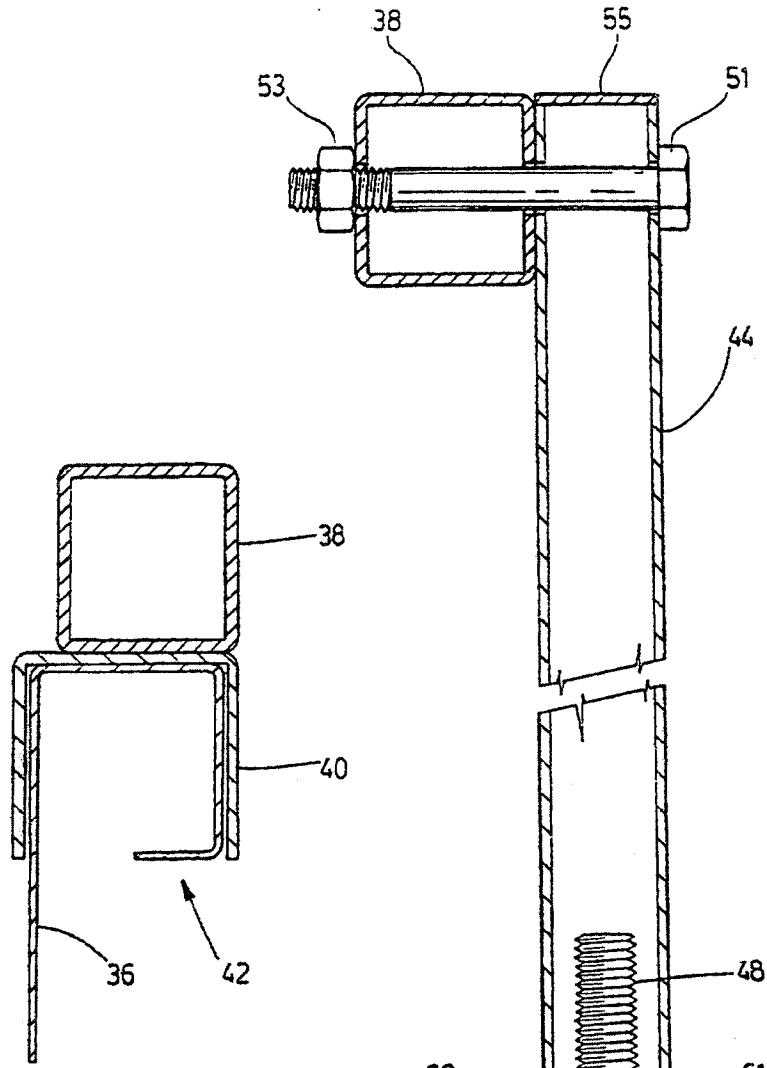

FIG. 3

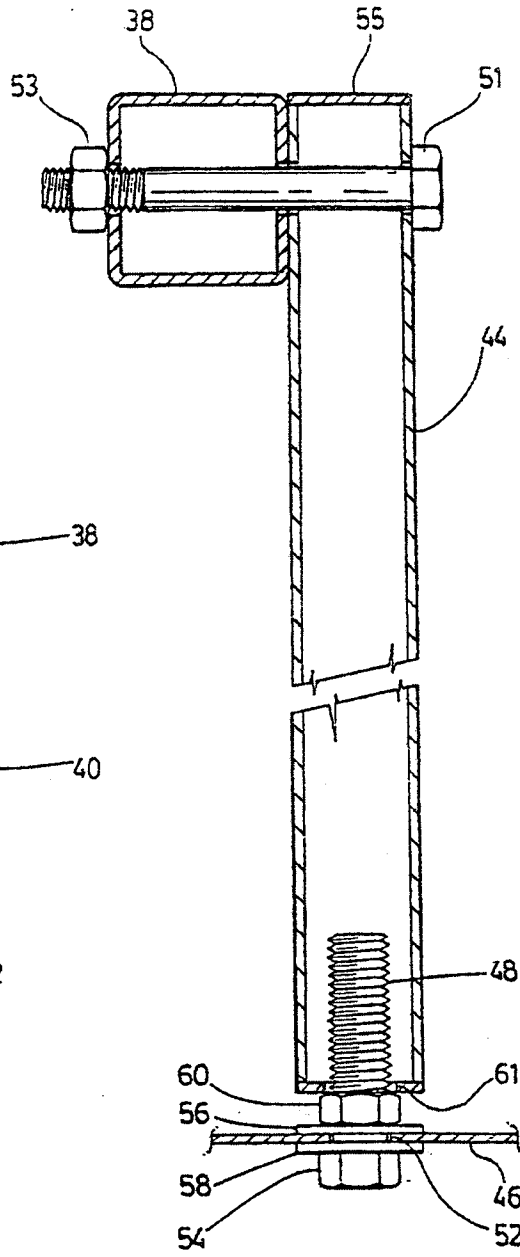

FIG. 4

## LOAD SUPPORTING RACK FOR ATTACHMENT TO PICK-UP TRUCK BOX

This invention relates to a rack for attaching to the box of a pick-up truck and for use in supporting or securing loads being transported in the truck.

Pick-up trucks are very popular vehicles and in part, this popularity is due to their load carrying capacity and compact size, together with other factors such as manoeuvrability, fuel economy and versatility. Unfortunately, the load carrying capacity is limited to some extent, by the size and configuration of the box which generally is of open construction. To transport a long ladder or other long load such as pipe or timber in a pick-up truck can be very cumbersome. Road safety rules limit the extent to which a load is permitted to extend beyond the ends of a vehicle. To attach the load to the side of the truck or to its roof may be damaging to the paintwork unless elaborate precautions are taken to protect it. Some permanent or semi-permanent fixtures have been used but these tend to be bulky and awkward to use.

Another disadvantage is that pick-up trucks are not generally equipped with anchor points to secure and restrain loads. In some cases, stake pockets are provided in the rim or lip of the box but these are often inadequate and of course, it may be necessary to keep them free for their intended purpose.

The object of this invention is to provide a rack for use with a pick-up truck which will facilitate the safe transportation of loads, particularly long loads, and which may be installed with minimal alteration to the truck.

According to this invention, there is provided a rack for installation on a pick-up truck having a cab and a box, the rack comprising support means for carrying a load and extending at least partly up the height of the cab to elevate at least a portion of the load above the cab roof, and locating means to removably couple the rack to an upright panel forming a forward part of the box, the locating means being adapted to restrict movement of the rack relative to the box.

A preferred embodiment of the invention is described below, by way of example only, and with reference to the accompanying drawings, in which:

FIG. 1 is a schematic side view of a pick-up truck equipped with a rack according to the invention and carrying a long ladder;

FIG. 2 is a perspective view of the rack according to the invention, looking from the rear of the box and toward the cab of the pick-up truck (shown in ghost outline);

FIG. 3 is a cross-sectional view taken on line 3—of FIG. 2 and drawn to a larger scale, illustrating the connection between a lower truss forming part of the rack and a front panel forming part of the box; and

FIG. 4 is a cross-sectional view taken on line 4-4 of FIG. 2 and drawn to a larger scale, illustrating the connection at the top between the truss and one of two legs forming part of the rack and the connection at the bottom between the leg and the floor of the box.

A typical pick-up truck is indicated generally by numeral 20 in FIG. 1 and includes a cab 22 at the front and a box 24 at the rear, supported on road wheels 26.

A rack 30 according to the invention is attached to the box 24 behind the cab 22 and supports a long ladder 32 near a forward end above the cab roof, the other end

of the ladder being supported by the tail gate 34 or rear panel of the box.

The rack 30 is more clearly illustrated in FIG. 2 which shows the truck 20 in ghost outline and the rack straddling the box 24 in an orientation which is transverse to the length of the box such that it is above a panel 36 forming a forward part of the box. The rack 30 includes a lower truss 38 of square steel tubing and having a length corresponding to the overall width of the box 24. A pair of inverted U-shaped brackets 40 (one of which is detailed in FIG. 3) depend from the lower truss 38 and are spaced from the ends of the truss inwardly of side panels 39 which form part of the box. The brackets 40 locate the lower truss on the top edge of the panel 36 which, as can be seen in FIG. 3, comprises sheet metal bent to form a rim 42 having a square cross-section.

A pair of legs 44, 45 also made of square steel tubing, depend from the lower truss 38 near the ends of the lower truss between the side panels 30 and the brackets 40. The legs 44, 45 reach a floor 46 forming part of the box 24 where they locate about respective anchors formed of bolts 48, 50. In FIG. 4, it will be seen that the lower truss 38 and the leg 44 are connected at substantially right angles to one another by a fitted bolt 51 traversing the leg 44 and the lower truss 38, the bolt 51 having a threaded outer end for receiving a securing nut 53 which, in this case, is positioned between the lower truss and the cab 22. Upon loosening of the nut 53, this arrangement permits the leg 44 to be pivoted on the bolt 51 into parallel relationship with the lower truss 38 for easy storage and shipping. An end cap 55 is welded on the top end of the hollow leg 44 to exclude precipitation and to trim the appearance of the rack 30.

The connection between the leg 44 and the floor 46 is also shown in FIG. 4. The bolt 48 is inserted through a hole 52 cut through the floor 46 with the head 54 lying below the floor and the threaded end extending above the floor (as drawn). Washers 56, 58 extend about the hole 52 around the bolt 48 with the floor 46 sandwiched in between and a nut 60 is threaded on the bolt 48 to secure it in position. An apertured locating shoulder 61 is welded on to the free end of the leg 44 and abuts the nut 60 with the threaded end of the bolt 48 received in the aperture and inside the leg 44.

An upright framework 62 is connected to the lower truss 38 by a pair of upwardly extending bars 64 made of square steel tubing and forming part of the framework 62. Near their upper end, the bars 64 are connected by an upper truss 66 substantially parallel to the lower truss 38 and spaced so as to extend at least partly up the height of the cab and to elevate at least a portion of the ladder 32 above the cab roof when the ladder is inclined and supported on the rack 30 and the tail gate 34. The top ends of the bars 64 are closed by welded end caps 67 in similar fashion to the leg 44. The framework 62 also includes a window guard 68 of flat bar lying between the lower and upper trusses 38, 66 and having the general shape of a trapezium. The parallel sides of the window guard 68 are orthogonal to the bars 64 and extend across the width of a rear window 70 forming part of the cab 22 with the bars lying in between. The other two sides of the window guard 68 are spaced from the edge of the cab 22 and are inclined so as to follow the contour of the cab for a pleasing aesthetic appearance.

Prior to installing the rack 30 on the pick-up truck 20, the leg 44 is pivoted into the operative orientation illustrated in FIG. 2, that is, at right angles to the lower truss

38, and the nut 53 is lightly tightened to maintain the relative configuration of the leg and the lower truss. The same procedure is repeated with the leg 45. It is understood that the bolts 48, 50 will have already been positioned on the floor 46 prior to positioning of the rack 30. The rack 30 is then lowered onto the box 24, with the brackets 40 receiving the rim 42 and simultaneously, the legs 44, 45 are lowered over the bolts 48, 50. The nut 53 and the corresponding nut on the leg 45 are given a final tightening and the rack is ready to use.

It will be understood that the weight of a load supported on the rack 30 is distributed on the entire length of the rim 42 and accordingly, the rim is unlikely to deform. Another feature of the rack is its stability, notwithstanding that it is easily removed from the truck. By locating about the rim 42 of the box, the brackets 40 restrict to and fro movement of the rack and side to side movement of the rack is restricted by engagement of the legs 44, 45 with the sides of the box. Any other movement having a horizontal component is further restricted by the location of the legs 44, 45 about the anchors or bolts 48, 50.

In use, any long load like the ladder 32 may be rested on the upper truss 66 and is preferably located between the bars 64 with one end extending over the roof of the cab 22. The ladder 32 is then secured with ropes tied onto the window guard 68.

Alternatively, a heavy load may be supported on the box floor 46 and secured to the framework 62 to prevent it from toppling over, in particular, a top heavy load such as a refrigerator, a barbeque, or a cement mixer.

In addition to anchoring tie ropes, the window guard 68 may conveniently be used to mount spot lights. Obviously, the window guard provides some protection to the window and any passengers from injury caused by a load being thrown toward the cab as may occur upon sudden deceleration of the truck. It will also be appreciated that the overall height of the truck fitted with the rack 30 will not be increased to any substantial extent with the result that the truck can be driven directly into low headroom parking areas without the inconvenience of having to dismantle the rack prior to entry.

Another attractive feature of the rack is that the legs can be folded parallel to the lower truss so as to decrease its width and conveniently, allow it to be stored on the box floor with its longitudinal axis parallel to the longer sides of the box.

It will be understood that several variations may be made to the above described embodiment of the invention. In particular, the configuration of the framework may vary considerably and will to some extent be dependent on aesthetic considerations determined by the shape of the cab. Furthermore, it will be understood that the junction between the lower truss and the legs may be made permanent, for example, by welding and that alternative means may be used to locate the legs on the cab floor.

I claim:

1. A rack for use in securing loads at the front of the box of a pick-up truck, the box having a forward upright panel terminating at a top edge and located behind the cab of the truck, the rack comprising:

a longitudinal lower truss for horizontal location on the upright panel of the box and extending across the width of the truck;

a longitudinal upper truss parallel to the lower truss and vertically spaced therefrom to support at least a portion of a load above the cab roof;

a pair of spaced upstanding members connecting the trusses to one another, and inwardly spaced from the ends of the lower truss, the ends of the upper truss being contiguous with the upstanding members;

load locating means extending upwardly from the upper truss and transversely spaced about the centerline of the truck so as to center a load supported on the upper truss;

rack locating means coupled to the lower truss and adapted for engagement with the top edge of said panel to retain the rack longitudinally with reference to the length of the truck and to prevent movement transversely of the truck, the location means including anchor means adapted to position the rack to prevent movement of the upper truss longitudinally of the truck relative to the lower truss; and

window guard means including anchoring means for attaching a load and comprising at least one elongate member having two ends and located between the lower and upper truss with the upstanding members inwardly spaced from the ends of said elongate member so that the window guard lies across a rear window forming part of the cab and protects the window and any passengers seated in the cab from a load thrust against the cab, said elongate member being made of flat bar having opposite narrow sides and opposite wide sides, the bar being oriented with said wide sides horizontal so as to minimize obstruction of the driver's view through the window.

2. A rack according to claim 1 in which the window guard means comprises two horizontally extending members vertically spaced between the lower and upper truss.

3. A rack for use in securing loads at the front of the box of a pick-up truck, the box having a forward upright panel terminating at a top edge and located behind the cab of the truck, the rack comprising:

a longitudinal lower truss for horizontal location on the upright panel of the box and extending across the width of the truck;

a longitudinal upper truss parallel to the lower truss and vertically spaced therefrom to support at least a portion of a load above the cab roof;

a pair of spaced upstanding members connecting the trusses to one another, and inwardly spaced about the ends of the lower truss, the ends of the upper truss being contiguous with the upstanding members;

load locating means extending upwardly from the upper truss and transversely spaced about the centerline of the truck so as to center a load supported on the upper truss;

rack locating means coupled to the lower truss and including channel means adapted to receive a rim defined by the top edge of said panel and thereby retain the rack longitudinally with reference to the length of the truck, a pair of leg means positioned for location adjacent to side walls forming part of the box to thereby prevent movement transversely of the truck, and anchor means coupled to the floor for locating the legs and positioning the rack to thereby prevent movement of the upper truss lon-

5

gitudinally of the truck relative to the lower truss;  
 and  
 window guard means including anchoring means for  
 attaching a load comprising at least one elongate  
 member having two ends and located between the 5  
 lower and upper truss with the upstanding mem-  
 bers inwardly spaced from the ends of said elon-  
 gate member so that the window guard lies across  
 a rear window forming part of the cab and protects  
 the window and any passengers seated in the cab 10  
 from a load thrust against the cab, said elongate

6

member being made of flat bar having opposite  
 narrow sides and opposite wide sides, the bar being  
 oriented with said wide sides horizontal so as to  
 minimize obstruction of the driver's view through  
 the window.

4. A rack according to claim 3 in which the window  
 guard means comprises two horizontally extending  
 members vertically spaced between the lower and  
 upper truss. 10

\* \* \* \* \*

15

20

25

30

35

40

45

50

55

60

65

TTAB – STK, LLC v. BACKRACK, INC.  
Cancellation No. 92049332 – Registration No. 3014986

## **EXHIBIT 2**

# **BACKRACK™**

October 11, 2007.

Rich Ackley  
Armor Deck  
280 Midland Avenue  
Saddle Brook, NJ. 07663.

Rich,

Effective November 15, 2007 we are announcing a price increase or perhaps more fitting, a price restructuring. As you may or may not be aware, the Canadian dollar has been on an unprecedented rise versus the US dollar. The 2002 average rate was 1.57. Compare that with today's rate of 0.98 and the effect on Backrack's profitability is obvious.

Unfortunately, the pricing structure we built together in the years of the strong US dollar had effectively subsidized a low price. Backrack's margins were provided by the spread between our currencies. This spread or margin has now been completely eroded to the point where it costs 1.02 to purchase a US dollar in Canadian funds. Simply stated, we can no longer sell Backrack products at the price levels in effect today. The Canadian and US currencies are now on par and our pricing needs to reflect that reality.

To assist us in this restructuring and provide insight and experience into the industry, we have employed the services and experience of Scafidi – Bolio & Associates. Scafidi – Bolio are now representing Backrack in your territory and will be working personally with me to transition the pricing to reflect the currencies at par.

Backrack has adjusted it's pricing to work off the industry standard Jobber Price and will discount off that price. This price adjustment or increase will be in effect for all WD's and Jobbers that sell our line.

I realize that this adjustment is going to be uncomfortable for Armor Deck. Pricing between you and your accounts is going to need to be adjusted as well as retail prices to maintain your margins. I know that you and Steve value the relationship we have between our companies as do I. It is my hope that we can continue our good relations in this new realm of level currencies.

We have built a very strong brand name, the brand that truck owners are asking for by name. We know that they perceive Backrack as the quality leader in this category. The price levels we are setting have worked well in Canada and in my

BR00619

opinion our products need to sell at a higher retail price than I am seeing on many websites. There is room for both of us to make more profit from this adjustment. Backrack must make more margins to continue to maintain the quality our customers expect and grow our business.

I expect that you will have questions and comments. Steve Bolio has offered to come and sit down with you. I had suggested that yourself, Mike Bolio and I sit down at SEMA and discuss where we are headed. As Backrack is growing we need to establish and maintain programs that follow more traditional industry standards. Scafidi – Bolio will certainly assist us in that. Let's arrange a date and time that we can meet face to face, ideally at SEMA.

Sincerely,

Adrian Jayne  
President, **BACKRACK™**  
*function and style for today's trucks*  
475 Wycroft Road, Oakville ON, L6K 2H2  
PHONE:(800)265-8137, FAX:(905)849.4116  
WEBSITE: [www.backrack.ca](http://www.backrack.ca)

BR00620

TTAB – STK, LLC v. BACKRACK, INC.  
Cancellation No. 92049332 – Registration No. 3014986

## **EXHIBIT 3**



From: STK [Product-Info@email.admail.net]  
Sent: Tuesday, April 22, 2008 2:31 PM  
To: Adrian Jayne  
Subject: Two New Truck Racks From STK

Follow Up Flag: Follow up  
Flag Status: Red

Problems Viewing this Email? [Click Here.](#)

**STK** NEW PRODUCT ANNOUNCEMENT

ASK HOW YOU CAN BECOME  
A **PREMIER DISTRIBUTOR!**

**STK  
PRO RACK**

**TWO TOUGH TRUCK RACKS**

PROUDLY MADE IN THE  
**USA**

**STK  
PRO GUARD**

**FEATURES:**

- Tough, Sturdy, Durable
- Easy No-Drill Installation
- Premium Quality Materials & Construction
- Custom Fit For Your Truck
- Flexible Use - Stylish Looks
- Thick, UV Stable Powder Coat Finish

BR00212

Unlike our competitor, Pro Rack® and Pro Guard™ truck racks are manufactured in the USA using 100% components that come from the USA. We do not use components imported from China.

PROUDLY MADE IN THE USA

QUALITY PRODUCTS PROUDLY MADE IN THE USA SINCE 1999

WWW.STKUSA.COM **STK** STKmail@STKLLC.COM

(888) 785-1574

2282 University Dr., Suite 1, Lemont Furnace PA 15456 (888) 785-1574 Fax: (724) 430-2488

| SK\_EML\_408\_01 |  
Not responsible for typographical errors.

---

[Click here to forward this email to a friend.](#)

[Click here to update your information or stop future mailings.](#)

BR00213

TTAB – STK, LLC v. BACKRACK, INC.  
Cancellation No. 92049332 – Registration No. 3014986

## **EXHIBIT 4**

**ARMORDECK™** new product line!



**STK PRO RACK** **STK PRO GUARD**

**TWO TOUGH TRUCK RACKS**

PROUDLY MADE IN THE USA

**SPECIAL INTRO PRICING!**

**PRO RACK: \$164<sup>95</sup>**

**FEATURES:**  
Tough, Sturdy, Durable  
Easy No-Drill Installation  
Premium Quality Materials & Construction  
Custom Fit For your Truck  
Flip-Up Lid - Stays Locked  
Thick UV Stable Powder Coat Finish

**ASK HOW YOU CAN BECOME A PREMIER DISTRIBUTOR!** **3/15/08 - 4/15/08**

5

**NEXT DAY Delivery!**

Contact your Armor Deck Sales Representative at **(800) 222-3325**

**ARMOR DECK** auto, sport-utility, van & truck accessories & equipment  
[www.ArmorDeck.us](http://www.ArmorDeck.us)  
280 N. Midland Ave., Bldg. S-1, Saddle Brook, NJ 07663 (800) 222-3325 Fax: (201) 703-1555

SK 208 18

Offer expires 4/15/08. Some restrictions apply. Not responsible for typographical errors.

403640

TTAB – STK, LLC v. BACKRACK, INC.  
Cancellation No. 92049332 – Registration No. 3014986

## **EXHIBIT 5**

**LIGHT BAR BRACKETS**

allows mounting of most styles of warning lights or antennas. Most Light Bar brackets bolt or clamp right to the Pro Rack™ without drilling.

72206 Arrow Light



72201 Driver Side 72201 Pass Side

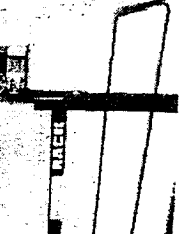

72207 Sport Light



72502 Drive Side 72504 Center 72503 Pass Side

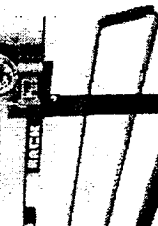

72508 Light Bar



72204C Center 72209 Side



72511 Multi-Use



The Pro Rack™ and Pro Guard™ are designed to support almost any type of accessory.

**TOOL BOX BRACKETS**

allow you to add your favorite crossbed tool box. The Tool Box Brackets provide an additional 2" of clearance under the tool box. Especially useful with extra deep boxes.

**TAIL BAR**

allows you to carry brackets & other long items with the Pro Rack™ or Pro Guard™. The Tail Bar simply drops into the rear stake pockets, is easily removed and does not interfere with opening or closing of the tailgate.

**ACCESSORIES & LIGHT BRACKETS**

Tool Box Bracket



Tail Bar



72219 Antenna Mount

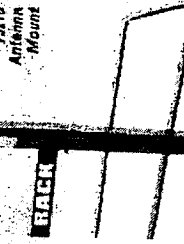

provides a convenient spot to mount your antenna. The antenna mount bolts to a Pro Rack™ without drilling and can be used in combination with Light Bar Brackets.

2282 University Drive, Suite 1  
Lemont Furnace PA 15456  
TOLL FREE (888) 785-1574  
ph: (724) 430-2477 fax: (724) 430-2488  
e-mail: STKmail@STKLLC.com www.STKUSA.com



STK Pro Guards and Pro Racks are trademarks of STK, LLC. All other marks are the property of their respective owners. © 2009 STK, LLC



**TOUGH RACKS**

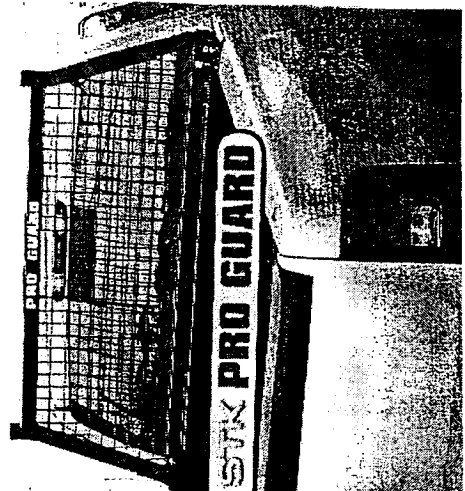

## PRO RACK

### TOUGH CONSTRUCTION

With robotically welded, 2" thick steel tubing, 5/16" flat-bar, thick reinforced steel brackets and rail plates that are custom designed for each application, the ProRack™ is tough enough to handle almost anything you can throw at it. Zinc-plated hardware, ultra-clean scale-free steel and an extra thick powder coated finish will keep the ProRack™ looking great throughout years of service.

### SENSIBLE PROTECTION

The STK ProRack™ offers more than great protection against personal injury or cab damage caused by shifting cargo. It also provides a sturdy structure to carry ladders, manage cargo, or to mount lights, toolboxes, antennas and more. In almost limitless combinations. Providing for an optimal rear view and structured so that the rear brake light is visible, ProRack™ delivers one of the most safety-conscious designs available.

### SIMPLE INSTALLATION

The ProRack™ mounting system employs the truck's stake pockets where available and in most cases installation does not require drilling. ProRack™ installs in minutes.

### FLEXIBLE USAGE

With multiple accessory brackets to choose from, you can mount any kind of strobe, light bar, arrow stick, antenna or toolbox in various configurations on your ProRack™. Perfect for your work truck, personal truck or a large fleet, ProRack™ can be installed with bedliners and toolboxes.



**TAIL BARS** allow you to carry boxes or other heavy loads with ease. ProRack™ or ProGuard™ for the STK™ simply direct the rear stake anchors, or other accessories, to their intended use with the safety of the is-back.

## STK PRO RACK

### STYLISH DESIGN

The unique curved shape of this ProRack™ follows the contours of the truck cab adding an element of style to this tough truck rack.

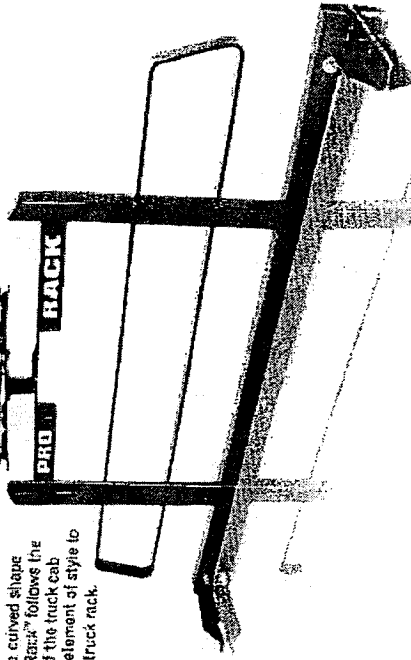

# THE MOST TOUGH HIGH RACKS

## PRO GUARD

### BUILT TOUGH

The ProGuard™ features an ultra sturdy 2" square tubular steel frame and a custom cut 3/16" diameter cold rolled steel mesh that robotically welded into the frame. For safety, a cutout maintains visibility of the third brake light.

ProGuard™ uses the same custom mounting system as the ProRack™, with thick reinforced steel brackets and rail plates to provide the strongest stake pocket installation available. Each ProGuard™ uses zinc plated

### BUILT SAFE

With the heaviest wire mesh screen on the market and tough 2" x 2" wide, thick steel tubing, the STK ProGuard™ delivers both form and function in a window and cab guard. Built strong to protect the cab against vehicle damage better than any other rack. This tough rack is ideal for use on work trucks that carry large tools, equipment, construction materials and other possibly dangerous cargo, yet maintains a fashionable look for any user.

### BUILT SIMPLE

Stake pocket mounting system is custom designed for each truck, eliminating the need for drilling into the brackets on most full size trucks. ProGuard™ installs in minutes.

### BUILT FLEXIBLE

Like the ProRack™, ProGuard™ can be installed with bedliners, rail caps and toolboxes. The flexible design enables camp and ladders to be secured, and provides for mounting of toolboxes and lights. ProGuard™ uses most ProRack™ accessory brackets and an optional 1 1/2" bar is available to carry longer cargo like pipe and lumber.

## STK PRO GUARD

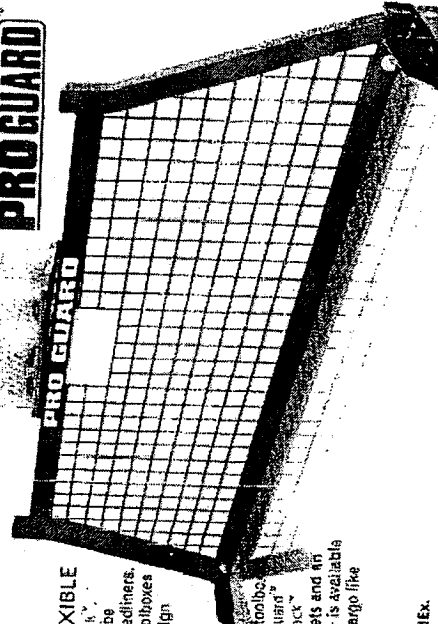

ProRack™ & ProGuard™ can ship via UPS or FedEx.

TTAB – STK, LLC v. BACKRACK, INC.  
Cancellation No. 92049332 – Registration No. 3014986

## **EXHIBIT 6**





auto, sport-utility, van and truck accessories & equipment



Home Products About Us Armor Paint Dealer Locator FAQ Site Map Become a Reseller Contact Us Search New Products

SEARCH BY: Categories - Select Category - Product Brand - Select Brand - **FIND!**

Product Information

HOME > PRODUCTS > STK® > PRO RACK

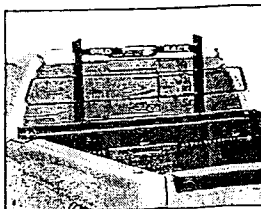

Pro Rack  
By STK®

STK Pro Racks offer stylish protection against personal injury or cab damage caused by shifting cargo. These racks provide a sturdy structure to carry ladders, manage cargo or to mount lights, toolboxes, antennas and more. Pro Racks come complete with installation hardware and brackets in one box. Part numbers ending in a "B" contain 21" brackets to accommodate most cross-bed style tool boxes. Tool box brackets may also be purchased separately. Extra wide tool boxes require a 31" long tool box bracket which can only be purchased separately.

LOOKING FOR THE BEST DEALS? [CLICK HERE TO FIND THE DEALER NEAREST YOU, FAST!](#)

This product is available for vehicles from the following manufacturers:

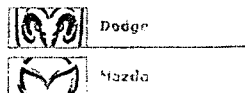
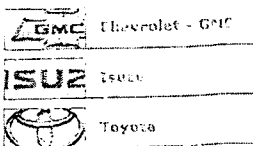

Select an auto manufacturer to view available applications. Chevrolet/GMC

CHEVROLET/GMC

Year	Model	With Standard Bracket	With 21" Tool Box Bracket	Image
04-08	Chevy Colorado & GMC Canyon	71104	71104B	N/A
82-04	Chevy S-10 & GMC Canyon*	71105		N/A
99-06	Chevy Silverado & GMC Sierra	71103	71103B	N/A
2007	Chevy Silverado & GMC Sierra Classic	71103	71103B	N/A
07-08	Chevy Silverado & GMC Sierra**	71106	71106B	N/A
88-98	Chevy/GMC	71102	71102B	N/A
68-87	Chevy/GMC*	71101		N/A

\* Tool Box Brackets are only available separately for this application.  
\*\* 2007 + Chevy/GMC If truck is equipped with a cargo management system, it must be removed or modified.

Looking for the best prices? Our [Dealer Locator](#) will find the **Armor Deck Dealers** nearest you, **FAST!**

BR00214

[Home](#)   [Products](#)   [About Us](#)   [Armor Paint](#)   [Dealer Locator](#)   [FAQ](#)   [Site Map](#)   [Become a Reseller](#)   [Contact Us](#)   [Search](#)

Special Features: [Armor Deck News](#) | [Featured Brand](#) | [Automotive Tips](#) | [Career Opportunities](#) | [Downloads](#)

©2008 Armor Deck. All rights reserved. Use of this web site constitutes acceptance of the Armor Deck [Website User Agreement](#). Date: Wednesday, May 07, 2008

Armor Deck, 290 North Midland Avenue, Saddle Brook, New Jersey 07663 | 1-800-222-3325 | [Terms and Policies](#) | [Related Resources](#)

**BR00215**

TTAB – STK, LLC v. BACKRACK, INC.  
Cancellation No. 92049332 – Registration No. 3014986

## **EXHIBIT 7**

**STK** ONLY STK HAS 2007 OVER-RAIL LINERS **SILVERADO** AND **GMC SIERRA** offering the best quality in tonneau covers & bedliners

| Home | About Us | Contact | Site Map | Dealer Locator | Links

STK is the leader in truck bed innovation, creating thermoformed truck protection products like drop-in bedliners molded of high density polyethylene with skid resistant technology and award winning tonneau covers.

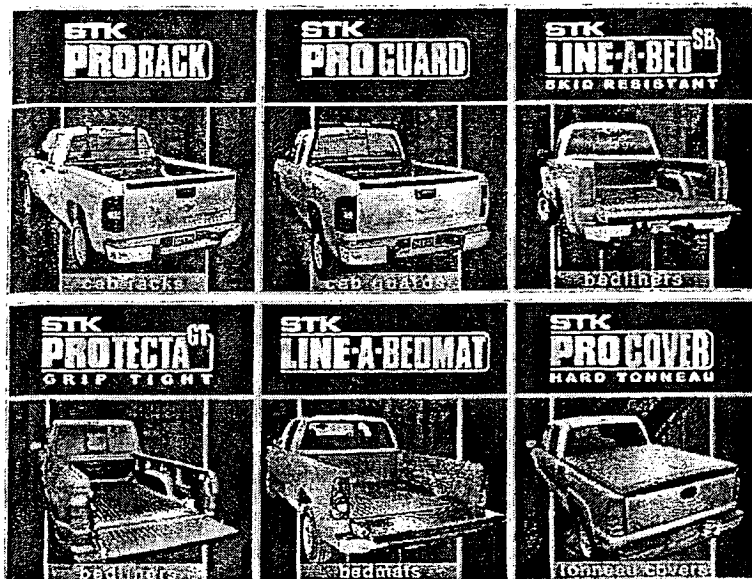

En Español

Need To Find A Dealer? [CLICK HERE](#)

**STK NEWS**

**OSHA SEMINAR : MOI EXPOSURE IN BED LINING OPERATIONS :**  
PRESENTED AT SEMA OFFROAD SHOW - INDIANAPOLIS  
The Occupational Health and Safety Administration (OSHA) estimates that there are over 2,000 spray-on ... | [Read More](#)

**STK, LLC BOLDLY ENTERS THE INTERNATIONAL BEDLINER MARKET**  
- 08/12/05  
Maximizing opportunities in the International Bedliner Market, STK has stepped up to the plate and raised the bar with their Line-A-Bed SR ... | [Read More](#) ([Spanish Version](#))

**GOVERNMENT REPORT: PREVENTING ASTHMA AND DEATH IN SPRAY-ON BEDLINER INDUSTRY** - 04/13/05  
STK presents findings from National Institute of Occupational Safety and Health report. ... | [Read More](#) [PDF](#)

[More Press Releases >>](#)

**DROP-IN** vs **SPRAY-ON**  
**BEDLINERS**

**WHAT MAKES STK DROP-IN BEDLINERS BETTER THAN SPRAY-ON BEDLINERS?**

Here are some things to consider when comparing STK drop-in bedliners to spray-on bedliners ...

**STK LINE-A-BED SR SKID RESISTANT**

Check out the **LINE-A-BED SR** TV commercial!

- [ABOUT US](#)
- [CONTACT INFO](#)
- [SITE MAP](#)
- [DEALER LOCATOR](#)
- [RELATED RESOURCES](#)



PRO RACK | PRO GUARD | PROTECTA | PROCOVER | LINE-A-BED | LINE-A-BEDMAT

©2008 STK, LLC. All rights reserved. Use of this web site constitutes acceptance of the STK [Website User Agreement](#)  
Date: Wednesday, May 14, 2008

STK LLC., 2282 University Drive, Suite 1, Lemont Furnace, PA 15456 | 888.785.1574 | STK News | Links

BR00225

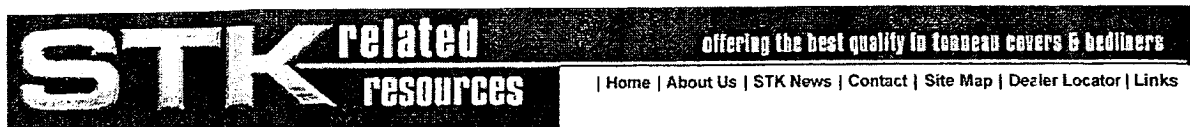

| PROTECTA | PROCOVER | LINE-A-BED | LINE-A-BEDMAT |

RELATED AUTOMOTIVE LINKS

## LINKS

### Featured Partners



#### **Armor Deck Dealer Locator**

America's leading distributor of quality truck accessories. We also keep an extensive inventory of many other truck accessories including bed liners, tool boxes, tonneau covers, painted wings, spoilers, grill guards, ladder racks, and many other automotive accessories.  
<http://dealers.armordeck.us/>

#### **MVS Wings - Custom Wings and Hood Scoops**

MVS manufactures only quality blow molded plastic spoilers, and has spent considerable time and money in developing a complete paint system designed to ensure a superior finish.  
<http://www.mvswings.us/>

### Featured Automotive Related Links

#### **1010tires.com - Tire & Wheel**

The absolute authority on tires and wheels featuring hundreds of high-performance, aftermarket wheels and tires.

#### **2 Chicks License Plate Frames**

Your number one source for personalized license plate frames for cars, trucks, SUV, ATV, campers, motor homes, vans, mini vans, RV, trailers, and motorcycles. We also have a Commercial Division for both frames and license plates for large volume buyers.

#### **4 X 4 Plus LLC**

Your 4 Wheel Drive Specialist In Parts and Conversions.

#### **A List Performance Mall / Auto Classifieds**

(Performance News & Information, Classic Auto Classifieds)

#### **5 Star Shine**

5 Star Shine Car Wax, Polish & Car Care. New Technology Eliminates Waxing Forever!

#### **Armor Deck Truck Accessories**

Distributor of automotive aftermarket accessories including bed liners, tool boxes, tonneau covers, wings and spoilers.

#### **Brookline Jaguar Service of Boston**

Recognized Jaguar Expert - Brookline Jaguar Service of Boston Massachusetts, has been providing quality Jaguar services, pre-owned sales and used Jaguar sales throughout New England for over 25 years.

#### **BuyAutoTruckAccessories.com**

BuyAutoTruckAccessories.com is America's leading online car and truck accessories superstore. We keep an extensive inventory of many other quality truck accessories including wings/spoilers, running boards, tonneau covers, bug shields, ladder racks and much more.

#### **Discount Tires**

Discount tires and wheels from the top manufacturers including Michelin, Goodyear, Dunlop and B.F. Goodrich. Your purchase benefits charity.

#### **EAutoWorks.com**

Custom car parts delivered to your door. Choose from import car body kits, SUV and truck accessories, car headlights, auto fog lights and more.

#### **HiPerformer - Remanufactured & Crate Engines**

Find high performance engines for Ford, Chevy, Mopar, Dodge Chrysler, Toyota and Import Engines. Our engines built to last.

#### **Hubcaps Haven**

Offering new and used hubcaps, wheels and accessories.

#### **Maximum Auto Parts**

We offer the lowest prices and free shipping on Replacement, OEM, Aftermarket, and Performance Parts.

#### **Paragon Performance**

Stainless Steel Braided Hose, Fuel Lines, Brake Lines, And More.

#### **Pickup Specialties**

Truck Accessory Online Superstore!

#### **RearMan.com**

Art Houser's Rear End Service & High Performance Parts

#### **Ruff Tuff**

We have been manufacturing America's Finest Custom Seat Covers since 1976 and are committed to providing you with the best quality products and customer service in the industry.

#### **Sport Trucks Specialty - Wheels, Tires and Accessories**

Wheels, Tires & Accessories for your Truck or SUV. We carry Hypertech, K&N, Eagle Alloys, Boss Motorsport Wheels, Nerf Bars, Grill Guards, Billet Grills and many more accessories to customize and enhance your Truck or SUV.

#### **Truck Accessorizer**

Online Accessory Store.

BR00226

**Truck Bed Covers**

Sells truck bed covers and truck bed accessories.

**Truck Stuff USA**

Welcome to Truck Stuff USA ... featuring name brand truck accessories at value prices!

**U-Need-A-Part**

Find used auto parts and used car parts from auto salvage yards throughout the U.S.. Our part locating services are FREE and available 24/7.

---

**More Automotive Links**

**Repair Shop Management Software**

Print Invoices/Estimates/Repair Orders. Store unlimited customers and vehicles with pictures. Track Sales and Inventory. Print Marketing PostCards. Easy to setup and use.

**America's Premier Auto Showrooms**

Listing service in four major arenas for selling Cars, Trucks, Suvs, and Vans.

---

**HOW TO SUBMIT YOUR SITE**

List Your Site! [Submit your site](#) information here! Note that we do not act upon emailed link requests. You must use our online form.

---

**RELATED AUTOMOTIVE LINKS**

[PRO RACK](#) | [PRO GUARD](#) | [PROTECTA](#) | [PROCOVER](#) | [LINE-A-BED](#) | [LINE-A-BEDMAT](#)

©2008 STK LLC. All rights reserved. Use of this web site constitutes acceptance of the [STK Website User Agreement](#).  
Date: Wednesday, May 14, 2008

STK LLC., 2282 University Drive, Suite 1, Lemont Furnace, PA 15456 | 888.785.1574 | STK News | Links

BR00227

STK

STK  
PRO RACK

offering the best quality in tonneau covers & bedliners

[| Home](#) | [| About Us](#) | [| Contact](#) | [| Site Map](#) | [| Dealer Locator](#) | [| Links](#)

| PRO RACK | PRO GUARD | LINE-A-BED | PROTECTA | LINE-A-BEDMAT | PROCOVER |

PRO RACKS

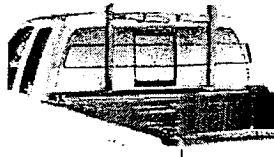

**TOUGH TRUCK RACKS**

STK Pro Racks offer stylish protection against personal injury or cab damage caused by shifting cargo. These tough truck racks provide a sturdy structure to carry ladders, manage cargo and more. Many accessory brackets are available to mount lights, antennas and toolboxes in multiple configurations. Pro Racks come complete with installation hardware and brackets in one box.

**VERSATILITY**

- [ Tail Bar ]
- [ Light Bar Brackets ]
- [ Tool Box Brackets ]
- [ View Application Guide ]

Multiple accessory brackets are available to mount strobes, light bars, arrow sticks, antennas and toolboxes in various configurations. Part numbers ending in a "B" include 21" tool box brackets (to accommodate most cross-bed style tool boxes). Tool box brackets may also be purchased separately. Extra wide tool boxes require a 31" long tool box bracket which can only be purchased separately.

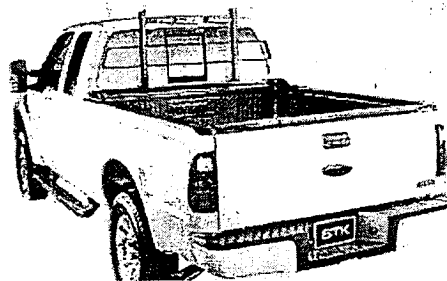
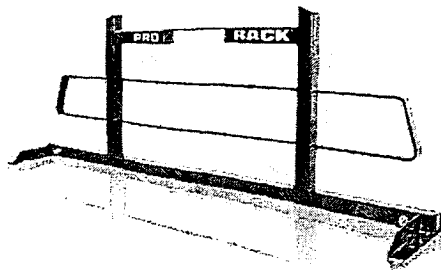

**Pro Rack Application Guide**

Year	Model	With Standard Bracket	With 21" Tool Box Bracket
<b>CHEVROLET/GMC</b>			
04-08	Chevy Colorado & GMC Canyon	71104	71104B
82-04	Chevy 5-10 & GMC Canyon*	71105	
99-06	Chevy Silverado & GMC Sierra	71103	71103B
2007	Chevy Silverado & GMC Sierra Classic	71103	71103B
07-08	Chevy Silverado & GMC Sierra**	71106	71106B
88-98	Chevy/GMC	71102	71102B
68-87	Chevy/GMC*	71101	
<b>DODGE</b>			
05-08	Dakota (including Quad Cab)	71302	71302B
87-04	Dakota (including Quad Cab)	71301	71301B
94-02	Dodge (except 2002 1500 Series)	71300	71300B
02-08	Dodge 1500 Series	71303	71303B
03-08	Dodge 2500/3500	71303	71303B
68-93	Dodge*	71101	
<b>FORD MOTOR COMPANY</b>			
75-96	Ford (also 97 F-250 HD & F-350 HD) 6.5'	71202	71201B
75-96	Ford (also 97 F-250 HD & F-350 HD) 8' Bed	71201	71201B
04-08	Ford F-150	71205	71205B
97-03	Ford F-150	71203	71203B

BR00228

04-08	Ford F-150 Super Crew 5.5' Bed	71206	71206B
00-03	Ford F-150 Super Crew 5.5' Bed	71204	71204B
93-07	Ford Ranger	71208	71208B
82-92	Ford Ranger	71301	71301B
99-08	Ford Super Duty F-250 - F-550	71207	71207B
<b>ISUZU</b>			
82-95	Isuzu	71301	71301B
<b>MAZDA</b>			
94-07	Mazda	71208	71208B
86-93	Mazda	71301	71301B
<b>NISSAN</b>			
05-08	Nissan Frontier	71302	71302B
86-04	Nissan Hard Body & Frontier*	71105	
04-07	Nissan Titan	71501	71501B
<b>TOYOTA</b>			
84-95	Toyota	71301	71301B
93-98	Toyota T100	71401	71401B
95-04	Toyota Tacoma	71301	71301B
05-08	Toyota Tacoma (2 parts)	71403-2 73405	
07-08	Toyota Tundra	71402	71402B
99-06	Toyota Tundra	71401	71401B

\* Tool Box Brackets are only available separately for this application.  
\*\* 2007 + Chevy/GMC If truck is equipped with a cargo management system, it must be removed or modified.

PRO RACK | PRO GUARD | PROTECTA | PROCOVER | LINE-A-BED | LINE-A-BEDMAT

©2008 STK, LLC. All rights reserved. Use of this web site constitutes acceptance of the STK [Website User Agreement](#).  
Date: Wednesday, May 14, 2008

STK LLC., 2282 University Drive, Suite 1, Lemont Furnace, PA 15456 | 888.785.1574 | STK News | Links

BR00229



TTAB – STK, LLC v. BACKRACK, INC.  
Cancellation No. 92049332 – Registration No. 3014986

## **EXHIBIT 8**



1.888.303.2654  
 Mon-Fri 9 am - 6 pm EST  
 Phone Order? Need Help?



- 1) Why Buy From Us?
- 2) Fast Shipping
- 3) Return Policy

**HEADACHE RACK**

**RELATED PRODUCTS**

- Bed Extender
- Bed Mats
- Bed Rails
- Bug Deflectors
- Cargo Bars/Nets
- Cargo Gate
- Chrome Accessories
- Door Handles
- Exhaust Tips
- Fender Flares
- Fender Trim
- Fuel Door Covers
- Mirror Covers
- Mud Flaps
- Putco Bed Caps
- Rear Window Graphics
- Side Window Covers
- Spoilers
- Taillight Covers
- Taillight Guards
- Tonneau Covers
- Vent Visors
- Wade Bed Caps

**TRUCK ACCESSORIES**

- Exterior Truck Accessories
- Interior Truck Accessories
- Garage Accessories
- Under Hood Truck Accessories
- Suspension Systems
- Ford Truck Accessories
- Chevy Truck Accessories
- Dodge Truck Accessories
- Toyota Truck Accessories
- Jeep Accessories

- Sitemap
- Return Policy
- Information Center

[Why Buy From Us?](#)

Secure Payment Gateway

**Ultimate Auto Accessories**

Raleigh, North Carolina

- [Home](#)
- [Search](#)
- [Contact Us](#)
- [Basket](#)
- [FAQs](#)

**Truck Headache Racks**

STK Pro Racks offer stylish protection against personal injury or cab damage caused by shifting cargo. These tough truck racks provide a sturdy structure to carry ladders, manage cargo and more. Can be Installed with Bedliners, Rail Caps and Toolboxes.

**Pro Guard**

- Flexible Design Enables Cargo and Ladders to be Secured and Provides for Mounting of Toolbox and Lights
- Heavy Wire Mesh Screen

**Pro Rack**

- Stylish design follows the contours of the truck cab
- Thick Reinforced Steel Brackets and Rail Plates

\*\* Choose your year, make, and model below to find specific applications, details, and pricing for your vehicle \*\*

**Truck Headache Racks**  
 (2007 Chevy Classic Owners: Select 2006 as your model year)

Year |  Select Make |  Select Model |

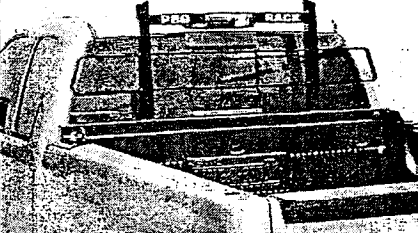
 Pro Guard Truck Rack	 Pro Rack Truck Rack
--	--

- [Home](#) | [Search](#) | [Contact Us](#) | [FAQ](#) | [Privacy Policy](#) | [Sitemap](#) | [Storemap](#)

**TRUCK ACCESSORIES** [Exterior Truck Accessories](#) | [Interior Truck Accessories](#) | [Under Hood Truck Accessories](#) | [Suspension Truck Systems](#) | [Ford Truck Accessories](#) | [Chevy Truck Accessories](#) | [Dodge Truck Accessories](#) | [Toyota Truck Accessories](#) | [Jeep Accessories](#)

**CAR ACCESSORIES** [Exterior Car Accessories](#) | [Interior Car Accessories](#) | [Under Hood Car Accessories](#) | [Honda Accessories](#) | [Ford Accessories](#) | [Chevy Accessories](#) | [Dodge Accessories](#) | [Toyota Accessories](#) | [Mitsubishi Accessories](#)

Search this Site



Google Search

WWW UltimateAutoAccessories.com

BR00232



Most items ship within 24 hours.

BR00233

TTAB – STK, LLC v. BACKRACK, INC.  
Cancellation No. 92049332 – Registration No. 3014986

## **EXHIBIT 9**

**BACKCRACK™**



**Made in Canada under licence**  
U.S. PATENT # 4867497 / CDN. PATENT # 1298663

**BACKCRACK INC**  
475 Wyecroft Road, Oakville, Ontario L6K 2H2  
(905) 849-3633 / U.S. TOLL FREE 1-800-265-8137  
[www.backcrack.com](http://www.backcrack.com)

TTAB – STK, LLC v. BACKRACK, INC.  
Cancellation No. 92049332 – Registration No. 3014986

## **EXHIBIT 10**



# THE SHAPE OF TODAY'S PICKUP TRUCK RACK



## GOOD LOOKS ARE IMPORTANT

**W**hen your customers have just spent thousands of dollars on a new pickup truck and walk into your showroom, you can be sure that they are looking for products that will both enhance the looks of their truck as well as ways to increase its value. It's likely that many of your customers are using that new truck for their business, or to perform some type of job. This customer can range from a farmer to a fleet manager but no matter what their title, they all want that new truck to look good because people take pride in their trucks. When you visited the SEMA show in November you stopped by and had a look at our product, the BACKRACK pickup truck rack. The Backrack provides an alternative to the traditional fullsize, four post, frame style ladder racks that people have been accustomed to. There is no question that these fullsize racks are functional, but do they really improve the looks of a new truck?

## YOUR TYPICAL BACKRACK CUSTOMER

Here's an example of your typical Backrack customer. Jerry Smith owns his own business, Smith Contracting. Jerry just bought a new 1994 Chevy pickup and decided that because he's worked so hard, he would get the truck with all the extras, after all he deserves it. Jerry comes into your showroom looking for a bedliner and maybe a tool box. Jerry carries the occasional ladder and lumber and has on past trucks, had a local fab

See our ad in...  
**Trucking Times**

shop make him up a fullsize ladder rack, but because Jerry's new truck is his pride and joy, he doesn't want one of those big, bulky racks on this truck and besides, Jerry wants his truck ready to go and doesn't want to leave it at the fab shop for a day. Just because Jerry is going to use his truck for work doesn't mean it has to look like a work truck. Jerry recalls seeing a truck on a job site recently with something called a "Backrack" on it but didn't know where to get one. Jerry sees a Backrack displayed in your showroom and after looking over the literature decides that it is just what he needs for his new truck, a rack that will keep his truck looking good, but will still enable him to carry his ladders, secure his equipment, and protect the front of the box from getting caved in, he knows how slippery those bedliners are. Jerry also likes the fact that the black finish matches the color of his new liner and that his liner won't get cut up in order to install the Backrack. Jerry decides to buy the Backrack, a bedliner, and a new tool box and happily heads down the road to the construction site. A few weeks later another customer walks into your showroom asking about this "Backrack" he saw on a truck he was behind at a stop light downtown. He had seen them around but didn't know where to get one, until now.

We have heard this story many times over. Word of mouth has sold a

## DECAL HAS THEM ASKING FOR IT

lot of Backracks because truck owners are truly satisfied with the quality, usefulness, and good looks of the Backrack. Every Backrack has the distinctive Backrack decal across the top of the rack where it can be seen

when you are driving down the road and was designed to let other truck owners know what they are looking at, and therefore what to ask for when they visit your showroom. Every Backrack also has a smaller decal near the drivers door with our toll free 800 # so that potential customers can call us to find a dealer in their area. We encourage all of our dealers to put their own decal with phone number on each rack they sell. We feel that by giving the Backrack a distinct and recognizable name, potential customers will be able to identify our product. You don't see many racks made at fab shops with Joe's Welding stickers on them.

## OUR DIRECT MAIL PROGRAM HELPS GET YOU STARTED

We have a product that is a proven seller, it's a GM accessory in Canada and has met GM's rigid quality standards. We are a growing company that needs dealers in many areas. We will gladly use our third class bulk mail program to introduce the Backrack to contractors and other proven markets in your area. We know who good potential customers are. You just need to provide us with a few pages from your local yellow pages and we will take care of the rest. I have included a copy of our latest mailer.

If you would like to offer your customers a new product that is as attractive as it is functional, give me a call at 1-800-265-8137. Somewhere in your pile of SEMA literature is our package that we sent you. Whether you are interested in quantities of 1, 10, or 100 our program is structured to meet your needs. When your the new kid on the block you do a little extra for your customers. Give us the opportunity to prove it to you.

# THE CONTRACTORS PICKUP NEWS

## A NEW GENERATION OF PICKUP TRUCK RACK IS NOW AVAILABLE IN.....[ YOUR CITY HERE ]

**C**hances are you use a pickup truck in your business, now there is a new truck rack available that was designed for contractors just like you. It's called the BACKRACK and it was designed for the new generation of pickup trucks to be functional and attractive, just like your truck. Many contractors value their trucks and want to keep them looking as good as possible, but when you put a big, bulky, fullsize rack on the truck you have lost the stylish good looks that your truck had when you drove it off the lot. Many contractors use their trucks for both business and personal use and therefore, demand that their truck looks good! The Backrack looks great but is strong, sturdy, and tough enough to take the abuse of a construction site.

### BACKRACK ACCESSORIES CUSTOMIZE YOUR TRUCK TO SUIT THE NEEDS OF YOUR BUSINESS

The Backrack alone is handy but, when you add our accessories it becomes even more practical. The REAR BAR accessory simply

Backrack for that sporty look. They are also great for lighting up the truck box for those after dark jobs. If you work on the highway and use light bars similar to the ones on the thruway authority trucks, we have a light bar bracket that allows you to conveniently mount these on the Backrack. Call us for more details.

### GET A HANDLE ON YOUR CARGO

Backrack does more than just carry ladders and mount lights, it is designed to make tying and securing your cargo easy. Notice that there is no mesh or screen on the rack, this is because it is easier to tie rope or ratchet straps to the Backrack, you can get your hands in behind as opposed to trying to fish rope through a mesh rack.

### SAY GOODBYE TO CUSTOM MADE RACKS...BACKRACK IS CONVENIENT

Custom made racks definitely serve a purpose, but you may find that they are expensive, and time consuming to have made, not to mention the fact that they often rust and detract from the trucks overall looks. Backracks are on the shelf and ready to be installed onto your truck in less than a half hour. They can be shipped UPS and installed in your garage or, have your local distributor shown below install it for you. Why not give them a call.

### BACKRACK IS FUNCTIONAL AND ATTRACTIVE, JUST LIKE YOUR PICKUP TRUCK

drops into the rear stake pockets of your truck to make carrying ladders and long loads easy. The UTILITY LIGHT BRACKETS simply bolt onto the rack so you can mount revolving and strobe lights without having to drill holes in the cab, best of all, these accessories look great and keep your truck looking it's best. Utility Light Brackets are available for both drivers and passenger side mounting as well as a center mounted bracket. SPORT LIGHT BRACKETS allow you to mount off road type lights onto the

**YOUR NAME, ADDRESS,  
AND PHONE # HERE**



TTAB – STK, LLC v. BACKRACK, INC.  
Cancellation No. 92049332 – Registration No. 3014986

## **EXHIBIT 11**

Volume 4 Issue 4

December 1993 \$3.00

# TRUCKING TIMES

PICKUP ACCESSORY TRADE MAGAZINE

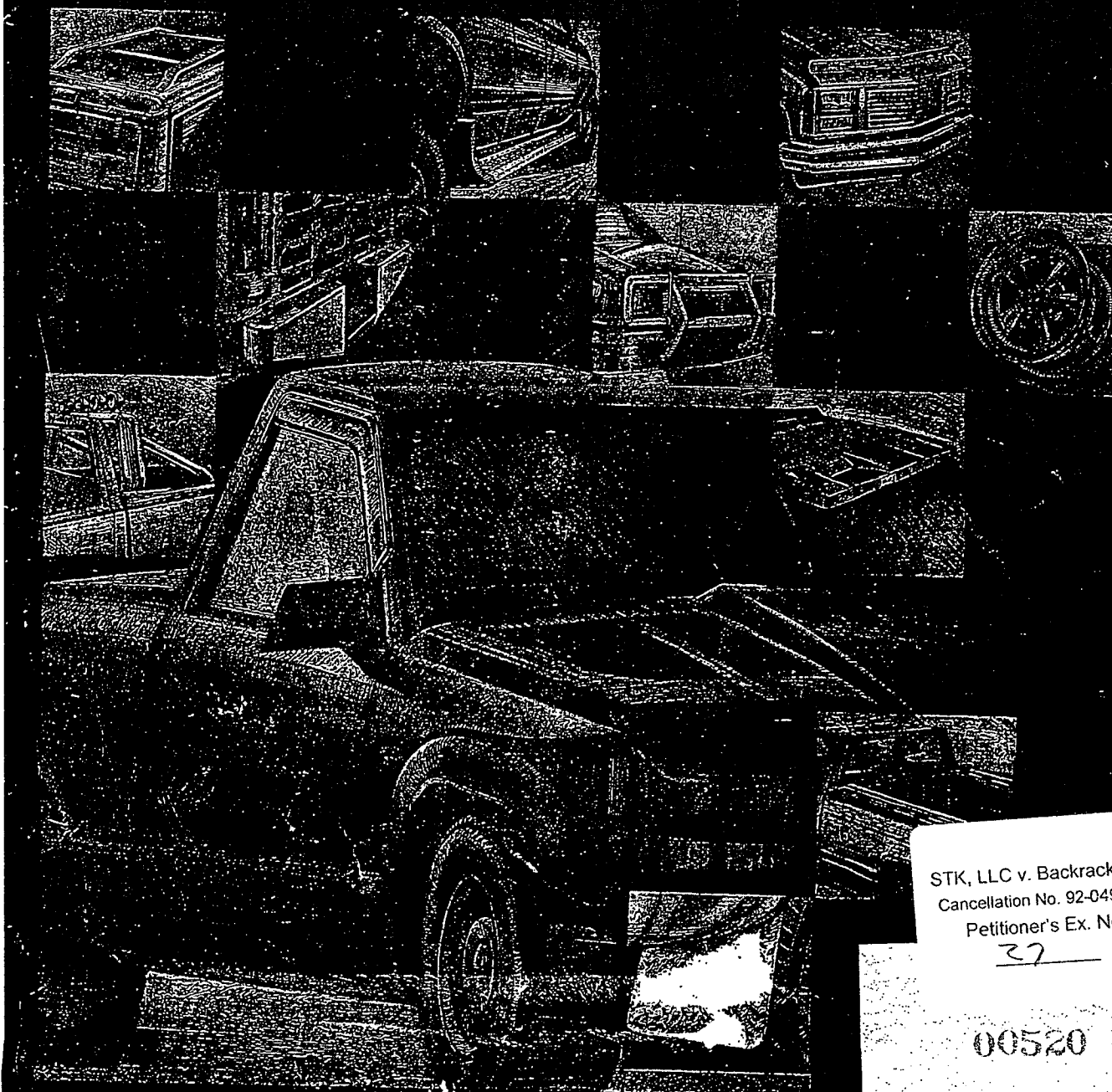

STK, LLC v. Backrack, Inc.  
Cancellation No. 92-049,332  
Petitioner's Ex. No.

37

00520

Resource Directory

# PRODUCT LISTINGS

TRUCKING TIMES

LOGIC BOXES FOR THIRD BRAKE (CHMSL) LIGHT .....	44	RADAR DETECTORS .....	
LOUVERS; SEE WINDOW LOUVERS .....	44	RAIN GUTTER DRIP CONTROL EXTRUSION FOR	
LUG WRENCHES, 4 WAY .....	44	DOOR DRIP PREVENTION .....	
LUGGAGE RACKS .....	44	REAR WIND DEFLECTOR; ALSO SEE WIND	
MANUALS .....	44	DEFLECTOR .....	
MIRRORS AND ACCESSORIES .....	44	REAR WINDOW SHADE .....	
MIRRORS, CUSTOM SLIDE-ON TOWING		REFLECTIVE FILM AND LETTERING FOR	
EXTENSIONS .....	44	CONFORMING TO CONSPICUITY LAW .....	
MUD FLAP ANTI-SAIL BRACKETS .....	44	REFUSE CONTAINERS THAT CAN BE OFF-LOADED	
MUD FLAP WEIGHTS .....	44	FOR ROTATION ON SITE .....	
MUD FLAPS/FLASH GUARDS .....	44	REMOTE CAR FINDER .....	
NITROUS OXIDE SYSTEMS; SEE PERFORMANCE		REMOTE CAR STARTERS .....	
ACCESSORIES .....	44	REMOTE POWER DOOR LOCKS .....	
NOVELTY AND COLLECTIBLE ITEMS; SEE		RESTORATION PARTS .....	
ACCESSORIES: PERSONAL .....	44	ROCKER PANEL SIDE MOLDING; ALSO SEE BODY	
OVERLOAD SPRINGS: ADJUSTABLE AIR COIL		SIDE MOLDING .....	
FOR STD., LOWERED, RAISED TRUCKS .....	44	ROLL BARS AND ACCESSORIES .....	
OVERLOAD SPRINGS: ADJUSTABLE INDIVIDUALLY		ROLL PANS .....	
FOR LEVELING .....	44	ROLL-OUT BED DRAWER FOR TRUCKS AND VANS	
OVERLOAD SPRINGS: COIL AUXILIARY .....	44	ROOF TOP STORAGE PODS; SEE STORAGE PODS ...	
OVERLOAD SPRINGS: LEAF .....	44	ROOF VENTS .....	
OVERLOAD SPRINGS: REAR SHOCK ABSORBERS .....	44	RUBBER SEALS, EXTRUDED .....	
PAINT, REFINISHING SUPPLIES .....	44	RUNNING BOARDS AND ACCESSORIES; ALSO SEE	
PERFORMANCE ACCESSORIES; ALSO SEE		GROUND EFFECTS AND STEPS .....	
COMPUTER CHIPS .....	44	S-HOOKS .....	
PILLAR MOLDING, STAINLESS STEEL (COWBOY		SAFES AND LOCK BOXES .....	
MIRRORS) .....	44	SAFETY CHAIN LINKS .....	
POP-UP SUNROOFS; SEE SUNROOFS .....	44	SAFETY CHAINS FOR TRAILER TOWING .....	
POST PULLER, BUMPER MOUNTED .....	44	SAND AND SALT SPREADERS/HOPPERS .....	
POWER DOOR LOCKS .....	44	SCREEN FRONTS; SEE GRILLE SCREENS .....	
POWER INVERTERS FOR 110 VOLTS FROM 12 VOLT .....	44	SEALANTS .....	
POWER WINDOW KITS .....	44	SEALS: EXTRUDED .....	
PUSH BARS; ALSO SEE BRUSH GUARDS .....	46	SEALS: FOAM .....	
RACKS; SEE BICYCLE, BOAT, HEADACHE, LADDER,		SEALS: SILICONE RUBBER EXTRUDED .....	
LUGGAGE, SKI, SURF, & VAN .....	46	SEAT ACCESSORIES, MISC. ....	

## IT'S A LIGHT RACK • LADDER RACK TIE DOWN RACK

IT'S A  
**BACKRACK™**  
FOR PICKUP TRUCKS

### MOUNT LIGHTS

on the Backrack and avoid drilling costly holes in the cab. 3 Models of light brackets accommodate strobes, beacons, and antennas. Eliminates water leaks, rust, and wiring hassles. Speeds installation and preserves trucks resale value.

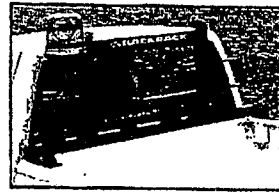

### SECURE CARGO

to the Backrack. No mesh design makes it easy to tie rope or secure ratchet straps. Won't reduce rear view visibility. Strong enough to restrain the heaviest cargo while it protects cab, employees, and truck resale value.

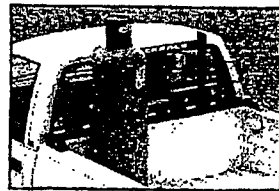

### CARRY LADDERS

on the Backrack with or without our Rear Bar accessory. Compact and attractive it won't be in the way. The Backrack is totally compatible with bedliners, no cutting required, mounts without drilling holes on most trucks, and is available for all pickups. Call or fax us for a free brochure.

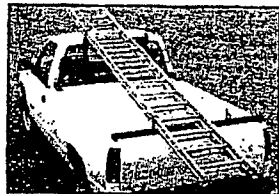

Call toll-free 1-800-265-8137

Fax: 905-875-4817

**BACKRACK INC.™**  
1994 Model meets CHMSL requirements



Natio



Get the lo



**TIN  
PA  
WA**

00521

For more information visit us at

TTAB – STK, LLC v. BACKRACK, INC.  
Cancellation No. 92049332 – Registration No. 3014986

## **EXHIBIT 12**

# BACKRACK™

## FUNCTION & STYLE FOR THE PICKUP OF THE 90'S

Today's pickup trucks look great, so why destroy their good looks with an awkward full frame rack? **BACKRACK** combines the strength & utility you demand on the jobsite with distinctive styling that compliments the appearance of your truck.

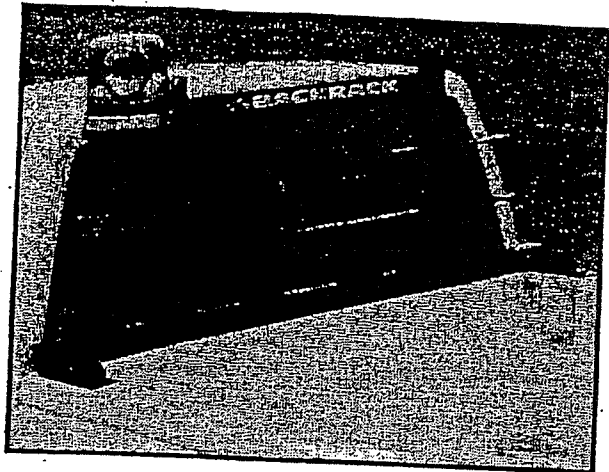

### MOUNT LIGHTS AND OTHER ACCESSORIES

with our **Utility Light Brackets**. 3 styles available: drivers side, passenger side, or centremount. Eliminates holes in roof and simplifies installation. Sport light brackets also available.

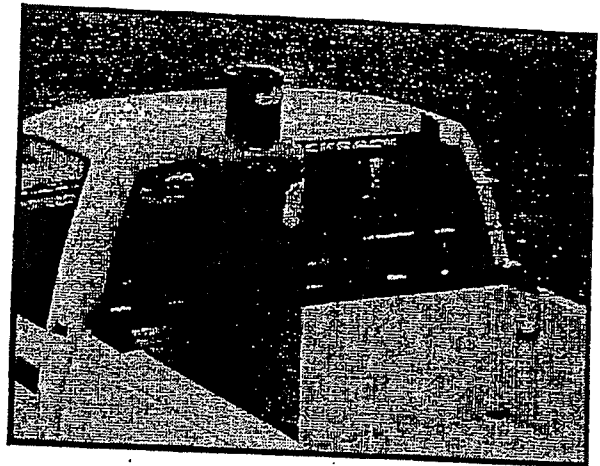

**SECURE CARGO** and tie shifting loads to the Backrack. Designed to make tying rope etc. simple. Backrack's unique mounting hardware securely attaches the rack to the stakepockets or rails of the truck.

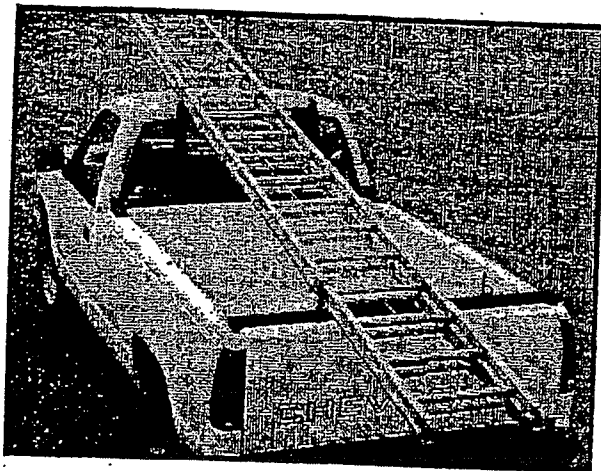

**CARRY LADDERS** and long loads on a Backrack with our **Rear Bar Accessory** for fullsize pickups. The rear bar simply drops into the rear stake pockets. An attractive alternative to fullsize, over the cab racks.

- ▶ Available for Fullsize and Compact Pickups
- ▶ Compatible with Bedliners - No Cutting Required
- ▶ High Quality - Heavy Gauge Steel Construction
- ▶ Black Powder Coat Finish
- ▶ Fully Welded Ends - No Plastic Plugs
- ▶ New 1994 Model (not shown)
- ▶ Meets CHMSL Regulations

## BACKRACK INC.™

U.S. Patent #4867497. Canadian Patent Pending. Backrack is a Trademark of Backrack Inc.

Backrack™ products are designed to help secure loads on pickup trucks. Because Backrack Inc.™ has control over how its products are used, our warranty is limited to material & workmanship used in the manufacture of our products.

AVAILABLE FROM:



**(905) 875-1557** Milton, Ont / Niagara Falls, NY  
**1-800-265-8137**

Easily installed accessories simply bolt on or drop into place.

All products are made of heavy gauge steel coated with a black polyester finish.

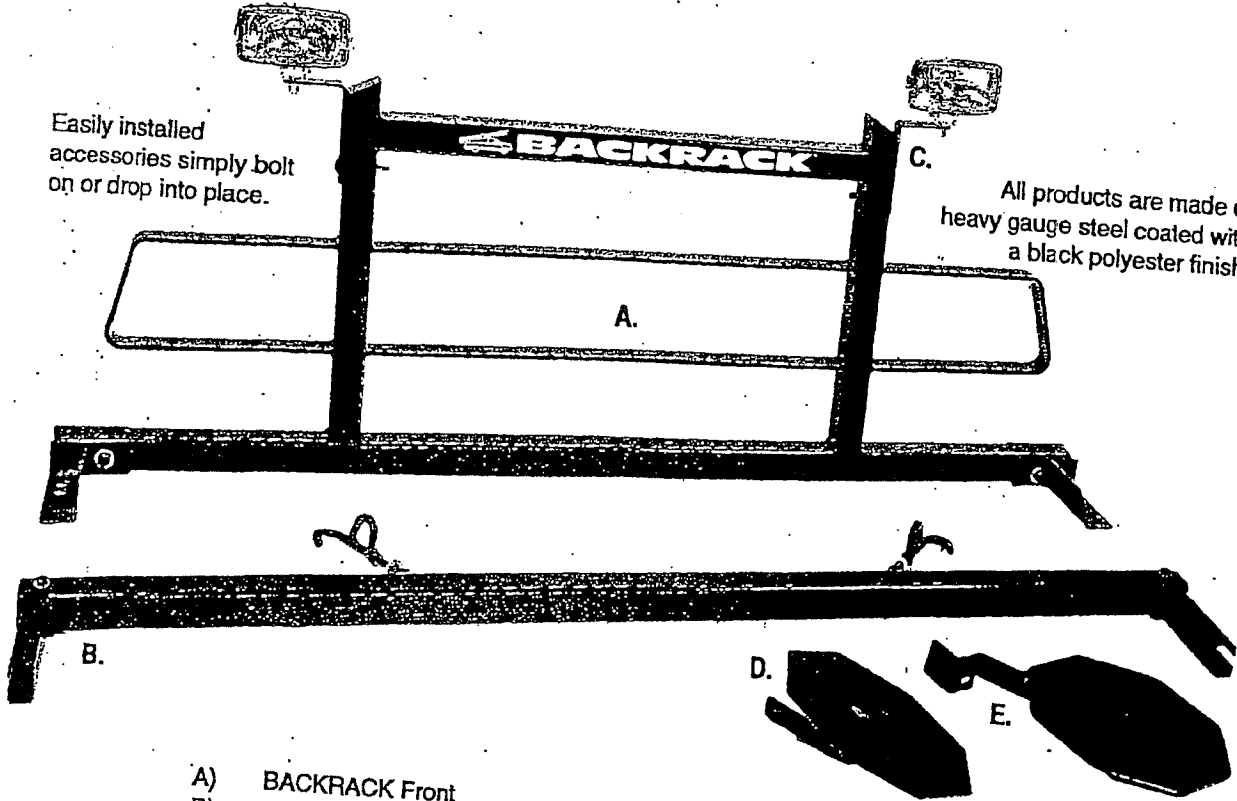

- A) BACKRACK Front
- B) BACKRACK Rear
- C) Sport light brackets

- D) Center Utility light bracket
- E) Side Utility light bracket

MODEL NO.	MAKE OF TRUCK	YEAR	WT. (LB.)
<b>A) BACKRACK</b>			
10506	FORD - FULLSIZE	UP THRU 94	61
10504	CHEV - FULLSIZE	UP THRU 87	61
10503	CHEV - FULLSIZE	UP THRU 94	61
10803	CHEV - STEPSIDE	88 THRU 94	61
10504	DODGE - FULLSIZE	UP THRU 93	61
10507	DODGE - FULLSIZE	NEW 94 MODEL	61
10312	CHEV S10-S15, NISSAN	UP THRU 94	55
10310	RANGER, DAKOTA, MAZDA	UP THRU 94	55
10310	ISUZU, TOYOTA, DODGE	UP THRU 94	55
<b>B) REARBAR</b>			
11506	FORD - FULLSIZE	UP THRU 94	40
11504	CHEV - FULLSIZE	UP THRU 87	40
11503	CHEV - FULLSIZE	UP THRU 94	40
11803	CHEV - STEPSIDE	88 THRU 94	40
11504	DODGE - FULLSIZE	UP THRU 93	40
11507	DODGE - FULLSIZE	NEW 94 MODEL	40
REAR BARS NOT AVAILABLE FOR 10310, 10312			
<b>C) SPORTLIGHT BRACKET</b>			
91005	(PAIR) MOUNTS TO ALL BACKRACKS		5
<b>D-E) UTILITY LIGHT BRACKETS</b>			
91001	DRIVERS SIDE MOUNT	ALL BACKRACKS	6
91002	CENTER MOUNT	ALL BACKRACKS	6
91003	PASSENGER SIDE	ALL BACKRACKS	6

BACKRACK ORDER DESK 1.800.255.9127

6 NYZ 0 0192  
6 NYZ  
6 138

TTAB – STK, LLC v. BACKRACK, INC.  
Cancellation No. 92049332 – Registration No. 3014986

## **EXHIBIT 13**

# MAKE YOUR PICKUP TRUCK MORE USEFUL WITH A **BACKRACK™**

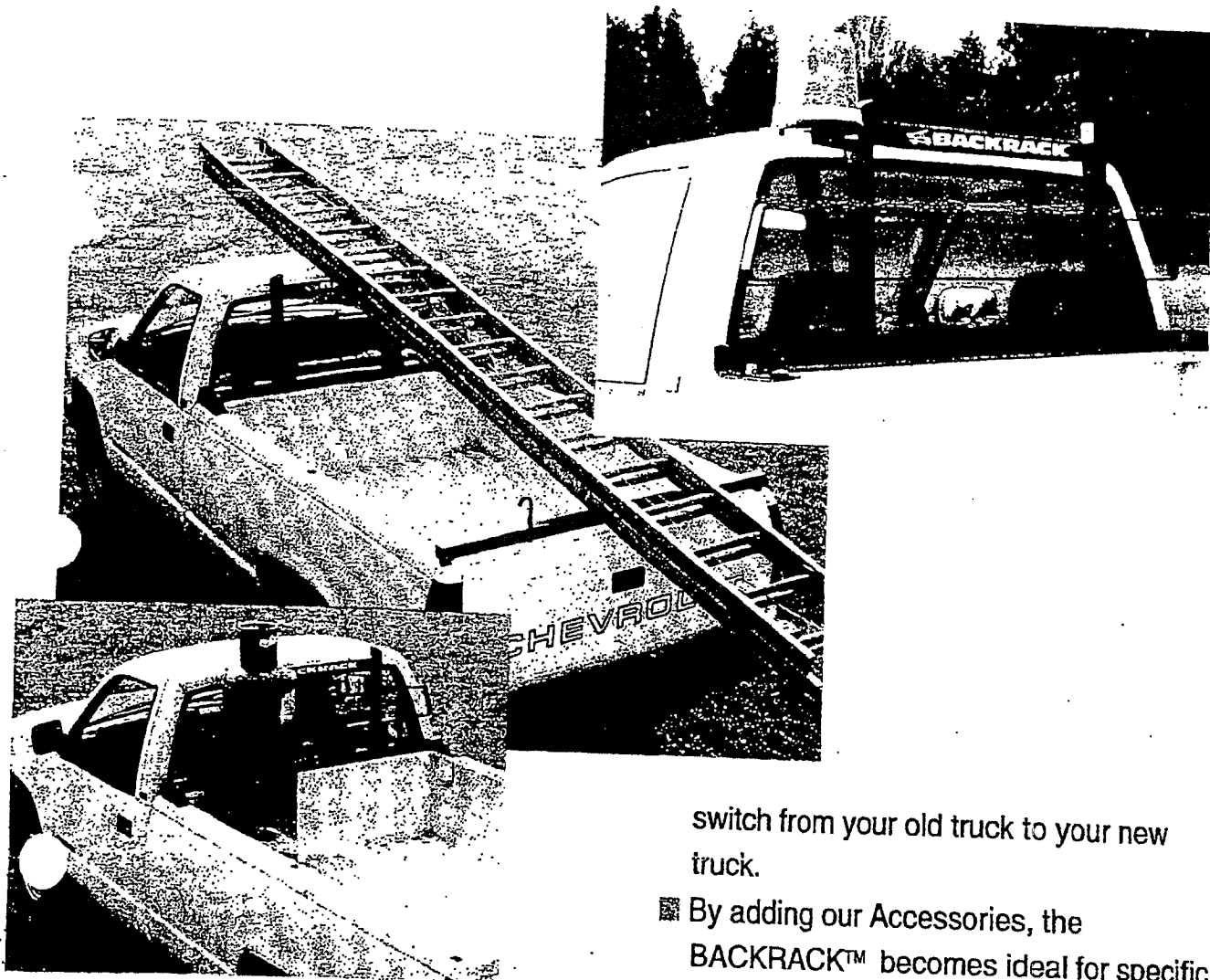

■ A BACKRACK™ behind the cab is very functional in providing a place to tie to, and a place to carry long loads i.e. ladders, lumber. The all welded steel construction makes it strong and black polyester coating makes it attractive. Easy to install and easy to

switch from your old truck to your new truck.

- By adding our Accessories, the BACKRACK™ becomes ideal for specific commercial applications such as landscape / ground maintenance / utilities / works departments / parks & recreation / construction etc.
- Ask your dealer about BACKRACK™ Accessories.



**The expert choice.**



# ADAPTABLE TO YOUR NEEDS.

If you bought your truck for work you can carry more material and equipment with a BACKRACK™ and Accessories.

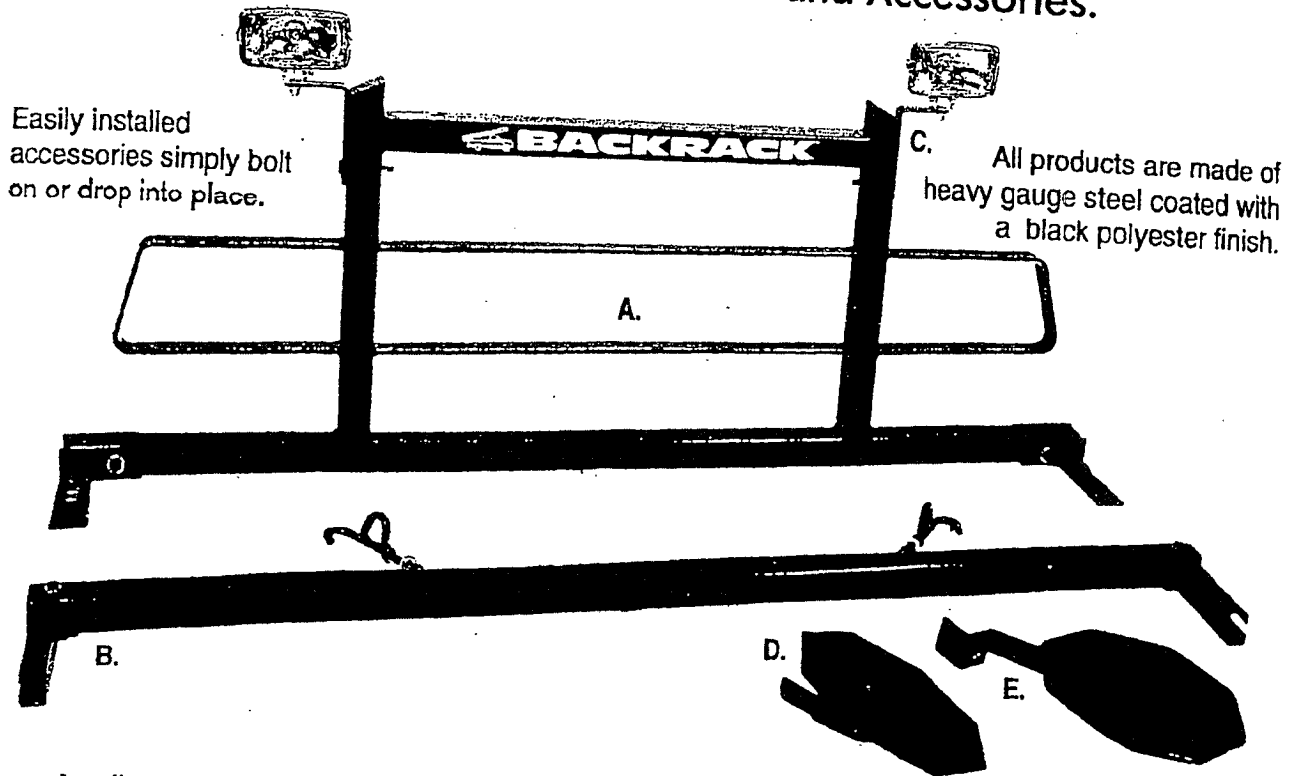

Applications for full size 1988-93 Full size CK1, 2, 3 Fleetside/Wideside (opt E63)

- A.) BACKRACK Front (Complete) #10952424
- B.) BACKRACK Rear (Complete) #10952425
- C.) Sport Light Brackets (Pair) #10952429 (Optional for 10952424)
- D.) Utility Light Bracket (Centre Mount) #10952428 (Optional for 10952424)
- E.) Utility Light Bracket (LH Mount) #10952426 (Optional for 10952424) (RH Mount) #10952427 (Optional for 10952424)
- F.) Sign Mount System #10952430 NOT SHOWN (Optional for 10952424)

Lamp package #10951635 pictured can be installed on the BACKRACK as an option.



## The expert choice.

DISTRIBUTED BY:

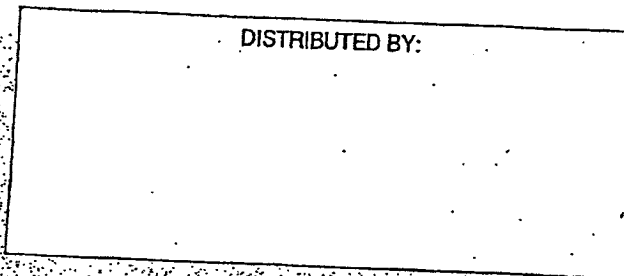

TTAB – STK, LLC v. BACKRACK, INC.  
Cancellation No. 92049332 – Registration No. 3014986

## **EXHIBIT 14**

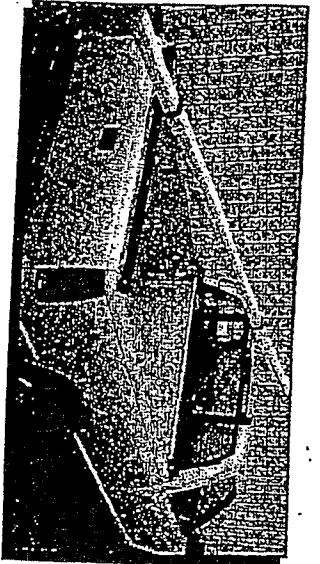

**CARRY LADDERS** and long cargo on the Backrack with or without our **REAR BAR** accessory. The Rear Bar simply drops into the rear stakepockets. Quick and easy to install and remove and doesn't interfere with opening and closing the tailgate.

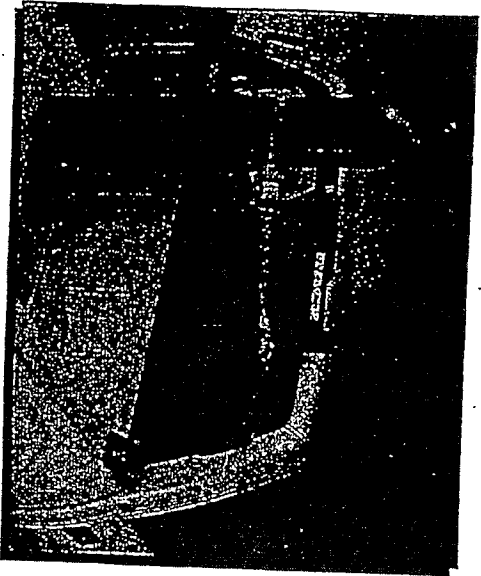

**SECURE CARGO** and tie shifting loads to the Backrack. Backrack's no mesh design makes it's easy to tie ropes, attach straps, or hook rubber cords used to hold cargo. The Backrack's strength and rigidity make it ideal for industrial, commercial, and construction applications.

## FUNCTION & STYLE FOR TODAY'S TRUCK

**ATTRACTIVE** - The Backrack's sleek styling compliments the good looks of today's pickups. Backrack is an attractive alternative to fullsize racks and is always there when you need it.

**VERSATILE** - Backrack's add on accessory **LIGHT BRACKETS** and **REAR BAR** allow you to design the rack to suit your specific needs.

**SECURE** - The Backrack's exceptional heavy-duty design and unique railmount installation give the Backrack incredible strength and rigidity when installed on your truck. Designed to last and take all the punishment you can give.

AVAILABLE AT:

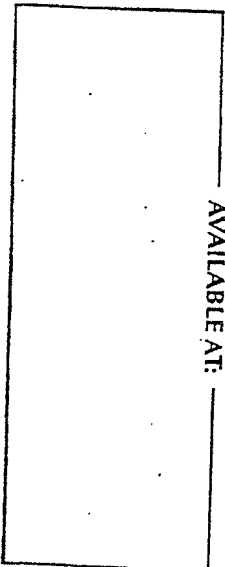

**BACKRACK INC.**  
Milton Ontario

Backrack products are designed to help secure loads on pickup trucks. Because Backrack Inc. has no control over how its products are used, our warranty is limited to materials and workmanship used in the manufacture of our products. U.S. Patent #4587497. Backrack is a trademark of Backrack Inc.

# BACKRACK PICKUP TRUCK RACK

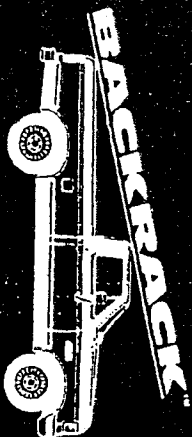

**Carry Ladders**  
**Secure Cargo**  
**Mount Lights**  
**On A Rack That**  
**Looks As Good**  
**As It Works**

# BACKRACK

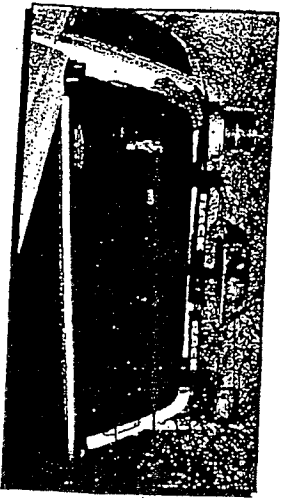

**MOUNT LIGHTS** and other accessories with our Light Brackets. Five styles to choose from, they simply bolt or clamp to the Backrack.

Above, Left: #91001, Center: #91002, Right: #91005 (pt).

Below in Center: #91006 Light Bar Brackets with #91007 DOT Brackets.

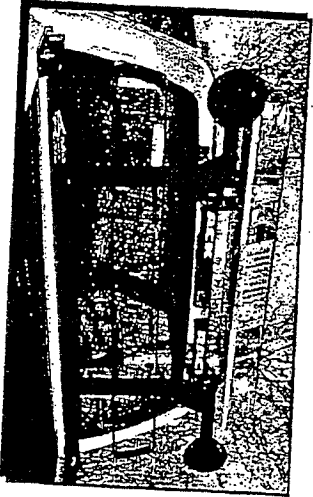

**IF YOUR TRUCK HAS A TOOLBOX** specify "TB" when ordering to receive our **TOOLBOX BRACKETS**. These brackets run 20" along the rail of the bed so the Toolbox can sit flush against the Backrack. Eliminates the need to drill holes in your truck to mount the Toolbox.



## STRENGTH & UTILITY YOU DEMAND ON THE JOBSITE, WITH DISTINCTIVE STYLING THAT COMPLIMENTS YOUR TRUCK



**FUNCTIONAL PROTECTION FOR YOUR INVESTMENT.** You have spent thousands on your new truck. Backrack protects it from dings and dents that inevitably occur. Just because your truck is being used for work doesn't mean that it has to look like a work truck: Backrack's distinctive, subtle styling looks as good as it works and was designed to fit your truck. An attractive alternative to fullsize and custom racks.

**QUALITY THAT STARTS WITH THE STEEL.** Backracks are made using "Pickled & Oiled" steel tubing, a clean, scale free steel for maximum rust resistance and a smooth finish. The flatbar that protects the window is "shotblasted" to remove any scale before assembly. Every intersection of material is fully welded for maximum strength. All nuts and bolts are plated with Zinc Dichromate to meet automakers specs. You won't find any sharp edges on a Backrack, we take the time to remove them. The Backrack is finished with an attractive and durable black powder finish that feels as good as it looks. Quality you can see.

**COMPATIBLE WITH BEDLINERS & TOOLBOXES.** Backrack's Railmount installation system makes it quick and easy to install, even on trucks with over the rail bedliners. No need to drill holes through the rail of your box on fullsize pickups, Backrack is secured by installing special bolts in your stakepocket. If you have a Toolbox, our toolbox brackets "TB" make installation easy. See photo on left.

TTAB – STK, LLC v. BACKRACK, INC.  
Cancellation No. 92049332 – Registration No. 3014986

## **EXHIBIT 15**

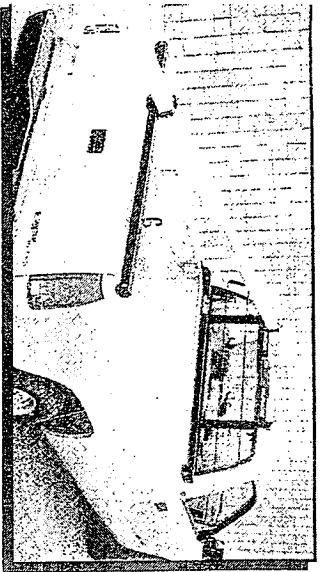

**CARRY LADDERS** and long cargo on the Backrack with or without our **REAR BAR** accessory. The Rear Bar simply drops into the rear stakepockets. Quick and easy to install and remove and doesn't interfere with opening and closing the tailgate.

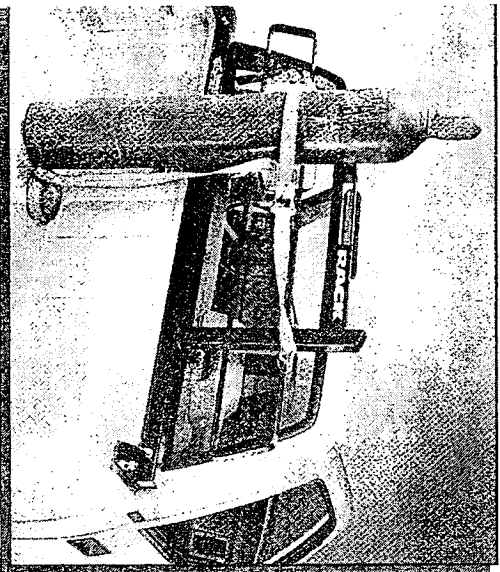

**SECURE CARGO** and tie shifting loads to the Backrack. Backrack's no mesh design makes it easy to tie ropes, attach straps, or hook rubber cords used to hold cargo. The Backrack's strength and rigidity make it ideal for industrial, commercial, and construction applications.

## FUNCTION & STYLE FOR TODAY'S TRUCK

**ATTRACTIVE** - The Backrack's sleek styling compliments the good looks of today's pickups. Backrack is an attractive alternative to fullsize racks and is always there when you need it.

**VERSATILE** - Backrack's add on accessory **LIGHT BRACKETS** and **REAR BAR** allow you to design the rack to suit your specific needs.

**SECURE** - The Backrack's exceptional heavy duty design and unique railmount installation give the Backrack incredible strength and rigidity when installed on your truck. Designed to last and take all the punishment you can give.

AVAILABLE AT:

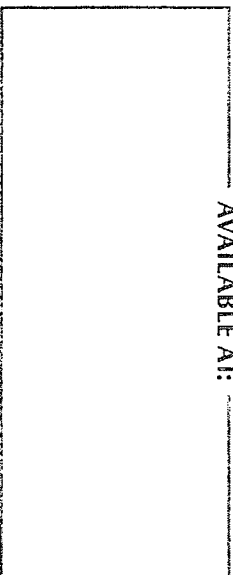

**BACKRACK INC.**  
Milton Ontario

Backrack products are designed to help secure loads on pickup trucks. Because Backrack Inc. has no control over how its products are used, our company is limited in materials and workmanship used in the manufacture of our models IS, US Patent #4117-197. Backrack is a trademark of Backrack Inc.

# BACKRACK PICKUP TRUCK RACK

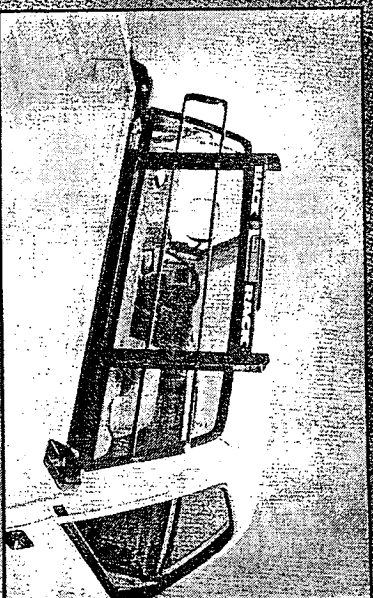

Carry Ladders

Secure Cargo

Mount Lights  
On A Rack That  
Looks As Good  
As It Works

# BACKRACK

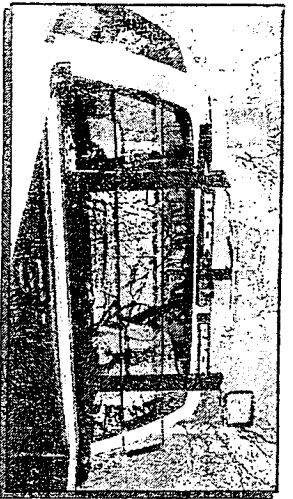

**MOUNT LIGHTS** and other accessories with our Light Brackets. Five styles to choose from, they simply bolt or clamp to the Backrack.

Above, Left: #91001, Center: #91002, Right: #91005 (pt).

Below in Center: #91006 Light Bar Brackets with #91007 DOT Brackets.

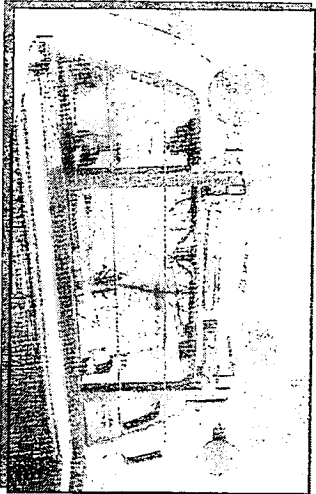

**IF YOUR TRUCK HAS A TOOLBOX** specify "TB" when ordering to receive our **TOOLBOX BRACKETS**. These brackets run 20" along the rail of the bed so the Toolbox can sit flush against the Backrack. Eliminates the need to drill holes in your truck to mount the Toolbox.

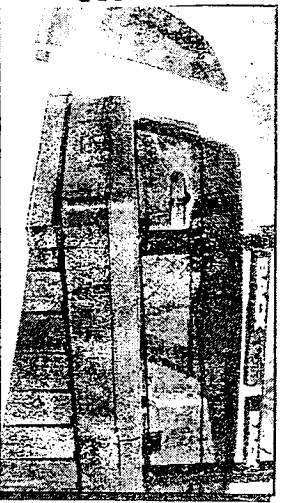

## STRENGTH & UTILITY YOU DEMAND ON THE JOBSITE, WITH DISTINCTIVE STYLING THAT COMPLIMENTS YOUR TRUCK

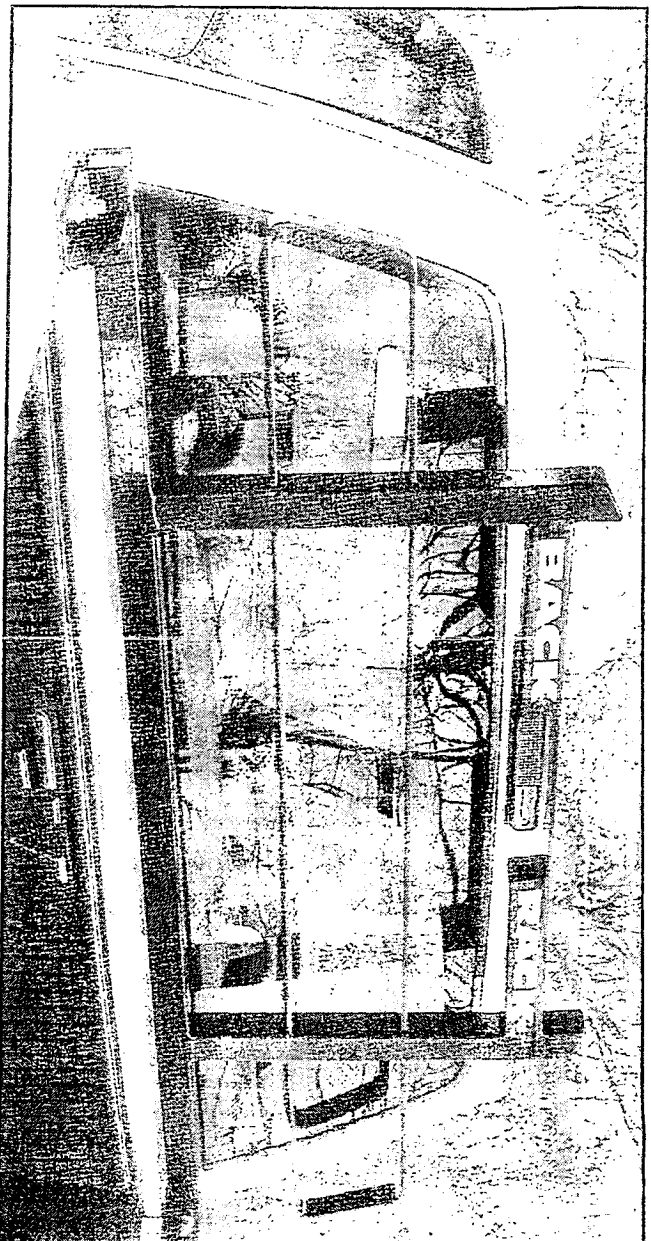

**FUNCTIONAL PROTECTION FOR YOUR INVESTMENT.** You have spent thousands on your new truck. Backrack protects it from dings and dents that inevitably occur. Just because your truck is being used for work doesn't mean that it has to look like a work truck. Backrack's distinctive, subtle styling looks as good as it works and was designed to fit your truck. An attractive alternative to fullsize and custom racks.

**QUALITY THAT STARTS WITH THE STEEL.** Backracks are made using "Pickled & Oiled" steel tubing, a clean, scale free steel for maximum rust resistance and a smooth finish. The flabar that protects the window is "shotblasted" to remove any scale before assembly. Every intersection of material is fully welded for maximum strength. All nuts and bolts are plated with Zinc Dichromate to meet automakers specs. You won't find any sharp edges on a Backrack, we take the time to remove them. The Backrack is finished with an attractive and durable black powder finish that feels as good as it looks. Quality you can see.

**COMPATIBLE WITH BEDLINERS & TOOLBOXES.** Backrack's Railmount installation system makes it quick and easy to install, even on trucks with over the rail bedliners. No need to drill holes through the rail of your box on fullsize pickups, Backrack is secured by installing special bolts in your stakepocket. If you have a Toolbox, our Toolbox brackets "TB" make installation easy. See photo on left.

TTAB – STK, LLC v. BACKRACK, INC.  
Cancellation No. 92049332 – Registration No. 3014986

## **EXHIBIT 16**



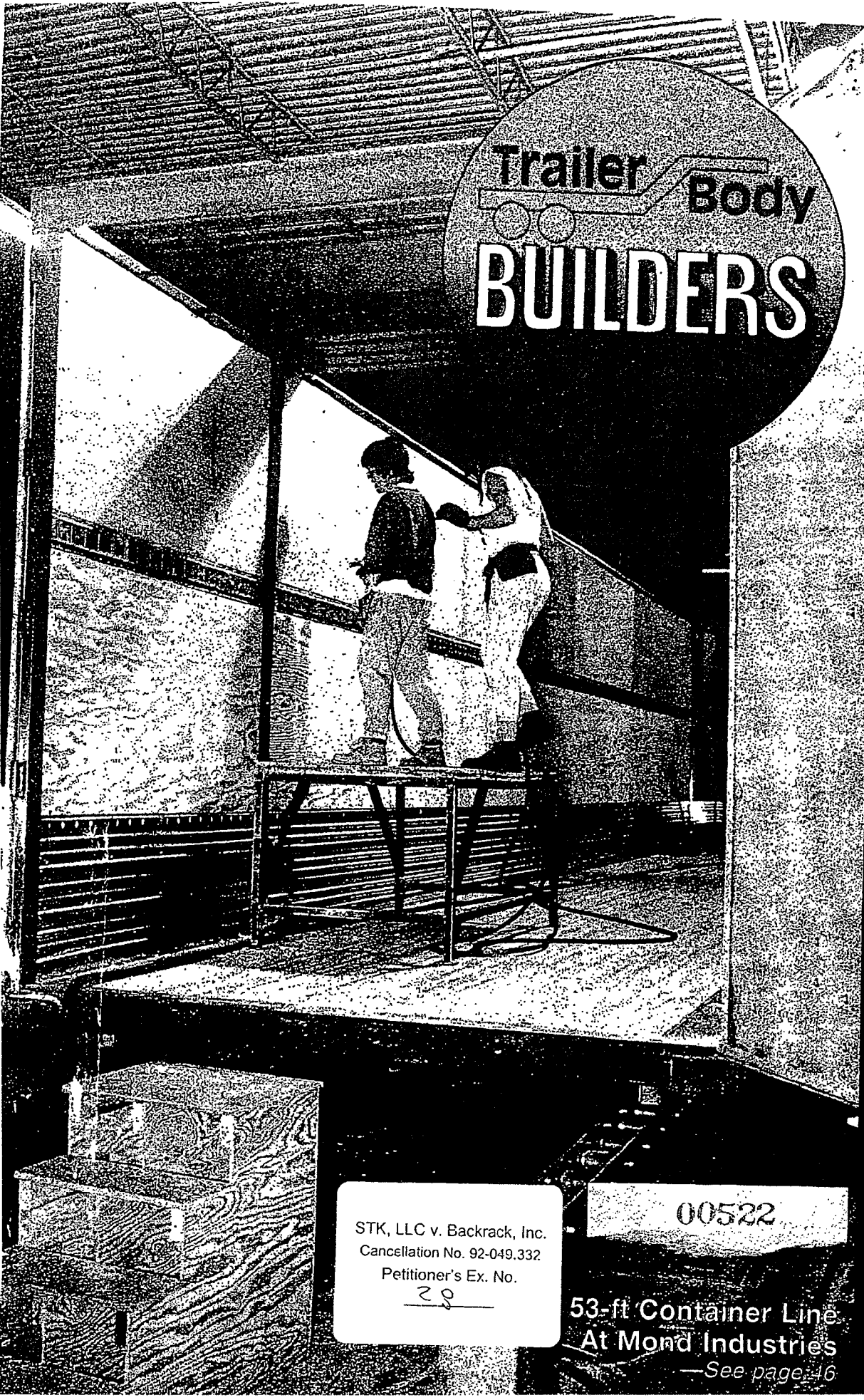

Trailer Body  
**BUILDERS**

See pages 155-400

1996 BUYER'S GUIDE ISSUE

STK, LLC v. Backrack, Inc.  
Cancellation No. 92-049.332  
Petitioner's Ex. No.

28

00522

53-ft Container Line  
At Mond Industries  
—See page 46

# BUYER'S GUIDE 1996

## Cab Air Suspensions

- Aptech, 13000 W Silver Spring Rd, Butler WI 53007
- Artman & Co, 350 Rt 66 N, Delmont PA 15626
- Monroe Truck Equipment Inc, 1051 W 7th St, Monroe WI 53566 (See ad p. 160)
- Power Packer, 12801 W Silver Spring Rd, Butler WI 53007

## Cab Enclosures

- Monroe Truck Equipment Inc, 1051 W 7th St, Monroe WI 53566 (See ad p. 160)
- Southco Industries Inc, 1840 E Dixon Blvd, Shelby NC 28150
- Swab Wagon Co Inc, 1 Chestnut Ave, Elizabethtown PA 17023
- Teledyne Specialty Equipment, Metal Products, PO Box 366, 460 Industrial Ave, Woodstock, Ont, CANADA N4S 7X6

## Cab Protectors

- Alum-Line Inc, PO Box 59, Cresco IA 52136-9601 (See ad p. 292)
- American Truck Equip Co, 5021 West 161st Street, Cleveland OH 44142
- Artman & Co, 350 Rt 66 N, Delmont PA 15626
- Backrack Inc, 6628 Twiss Rd, RR #3, Campbellville, Ont, CANADA L0P 1B0 (See ad p. 186)
- Bimco Inc, PO Box 98, Bloomfield IA 52537
- Crysteel Mfg Inc, Hwy 60 East, PO Box 178, Lake Crystal MN 56055 (See ad p. 217)

## (Cab Protectors Contd)

- DC Van Outfitters Ltd, 60 Esna Park #5, Markham, Ont, CANADA L3R 1E1
- Highway Products Inc, 6241 Crater Lake Hwy, Central Point OR 97502 (See ad p. 342)
- Johnson Hydraulic Mfg Co, 6315 W Fauber Rd, Peoria IL 61607 (See ad p. 255)
- Knaack Mfg Co (Weather Guard), 420 E Terra Cotta Ave, Crystal Lake IL 60014
- Koneta Rubber Co, 700 Lunar Dr, Wapakoneta OH 45895 (See ad p. 274)
- Luverne Truck Equip Inc, 1200 Birch St, Brandon SD 57005-2001 (See ad p. 242)
- Masterack, Div Leggett & Platt Inc, PO Box 100055, Atlanta GA 30348 (See ad p. 278)
- MEG/Gallon Dump Bodies Inc, 500 Sherman St, Galion OH 44833 (See ad p. 197)
- Merritt Equipment Co, 9339 Hwy 85, Henderson CO 80640 (See ad p. 191)
- Perfection Dump Bodies & Hoists, 5620 Industrial Rd, Ft Wayne IN 46825
- Pro-Tech Industries Inc, 14011 NE 3rd Ct, Vancouver WA 98685 (See ad p. 345)
- Road Gear, PO Box 4586, Hwy 243 S Industrial Park, Russellville AL 35653 (See ad p. 31)
- Southco Industries Inc, 1840 E Dixon Blvd, Shelby NC 28150
- Special Trucks Inc, 4930 Old Maumee Rd, Fort Wayne IN 46803
- Sturdy-Lite Inc, 2100 Industrial Blvd, Bristol TN 37620
- System One Modular Truck Equip, PO Box 592, Pennington NJ 08534 (See ad p. 284)
- Vanguard Mfg Co Inc, 90 Temple Rd, New Ipswich NH 03071 (See ad p. 224)
- T L Wood's Inc, PO Box 204, Stewartville MN 55976

## Cable Controls (also see Push/Pull Cable)

- Buyers Products Co, 7700 Tyler Blvd, Mentor OH 44060
- Cablecraft, PO Box 11372, Tacoma WA 98411-0372
- Dana Corp, Chelsea Auxiliary Power, PO Box 321, Toledo OH 43697 (See ad Cover 4)
- Felsted Div Furon Co, 8351 Country Hwy 245, Holmesville OH 44633-0068
- Fisher Controls Intl Inc, PO Box 8004, McKinney TX 75069
- Morse Controls, 21 Clinton St, Hudson OH 44236
- Muncie Power Products Inc, PO Box 548, Muncie IN 47308 (See ad p. 281)
- Wescon Products Co, 2533 S West St, Wichita KS 67277 (See ad p. 187)

## Cables (see Wire Rope & Cable)

## Cabs, Crew (see Crew Cabs)

## Cabs, Sleeper (see Sleeper Cabs)

## CAD/CAM Systems

- Applied Production Inc, 200 Techre-Center, Suite 202, Milford OH 45150
- CADSI, 2651 Crosspark Road, Coralville IA 52241
- Progressive Software Corp, 1149 Stone Dr, Suite 100, Harrison OH 45030

## Caps, Fuel-Tank Locking

- Cleveland Tank & Supply Inc, 1920 Scranton Road, Cleveland OH 44113 (See ad p. 335)
- Sloan Transportation Products, 534 East 48th St, Holland MI 49423 (See ad p. 176)
- Stant Mfg Inc, A Stant Company, 1620 Columbia Ave, Connersville IN 47331-1696
- Velvac Inc, 2900 S 160th St, New Berlin WI 53151

## Car Carriers, Slide-Back

- AATAC, 4000 Sam Wilson Rd, Charlotte NC 28214
- E R Buske Mfg Co Inc, PO Box 129, Pocahontas IA 50574
- Chevron Inc, 7320 W Market St, Mercer PA 16137
- Jerr-Dan Corporation, 1080 Hykes Road, Greencastle PA 17225

## Cargo Control Equipment

- Ankra International, 4880 W Rosecrans Ave, Hawthorne CA 90250
- Cargo Equipment Corp, 640 Church Rd, Elgin IL 60123
- Cargo-Tech, 3901 York Street, Denver CO 80205
- Cargotrol Corp, PO Box 3487, Hayward CA 94540 (See ad p. 341)
- Cargowall Ltd, 75 Courtice Court, Courtice, Ont, CANADA L1E 2T4 (See ad p. 304)

## BACKRACK

OFFERS YOUR FLEET CUSTOMERS MUCH MORE THAN JUST CAB PROTECTION.

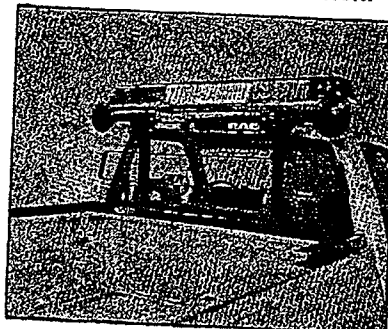
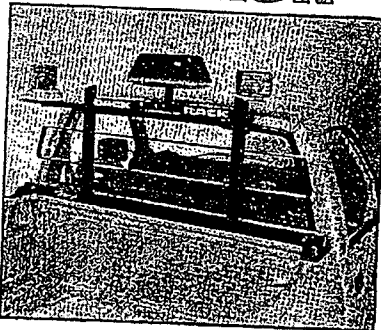

The quality, strength and versatility of the Backrack has created new standards for cab guards. The Backrack has what fleets want, and more are specifying the Backrack everyday. With the multiple applications and durability of a Backrack, there is no better choice for the pickup trucks of today's fleets.

- Accessory Light Brackets are designed to bolt or clamp right onto the Backrack, allowing any strobe, beacon, light bar, other light or antenna to be mounted without drilling into the truck. Quicker, easier wiring reduces installation time of lights.
- Special Toolbox Brackets eliminate drilling into the rails to mount a toolbox, and the Backrack is secured with custom-fit bolts right into the stakepockets. Installs quickly and easily, with no drilling on most trucks, saving time and money.
- Strong and sturdy, the Backrack is built from 2" pickled and oiled steel tubing that is scale-free and finished with a black powder coat. The flatbar is shotblasted, and all hardware is gold-zinc plated.

**BACKRACK INC. 1-800-265-8137**

00523

★ Bold Face Type Indicates Advertiser

TTAB – STK, LLC v. BACKRACK, INC.  
Cancellation No. 92049332 – Registration No. 3014986

## **EXHIBIT 17**

# BACKRACK

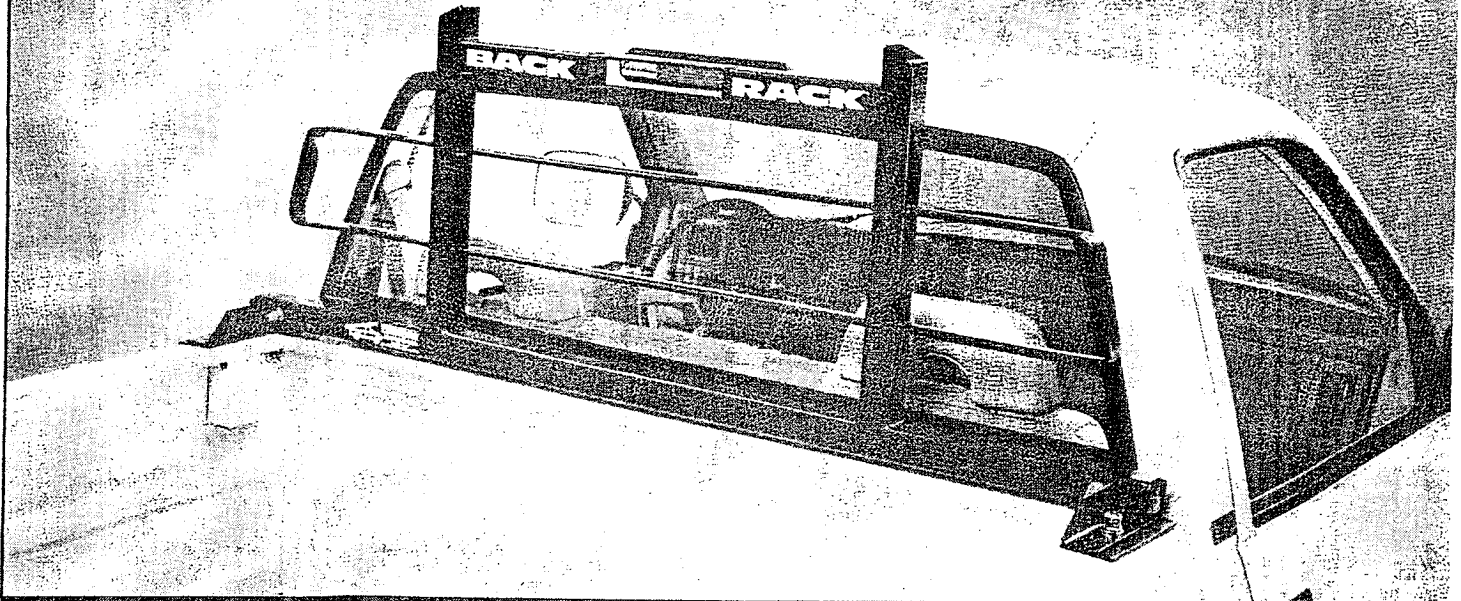

## FUNCTION & STYLE FOR TODAY'S PICKUP TRUCKS

Today's pickup trucks look great, so why destroy their looks with a full frame rack? There is no reason to damage your truck by drilling holes into the pickup to install lights or toolboxes; the Backrack offers the versatility you expect from a cab guard. Built with heavy gauge "pickled and oiled" steel tubing that gives a clean, scale-free finish for maximum rust resistance, the Backrack provides strength and utility while maintaining the style of your pickup truck.

Mount all styles of warning lights or antennas using one of the many models of accessory Light Brackets. Eliminate the need to drill into the roof of the pickup truck - all Light Brackets bolt or clamp right to the BACKRACK.

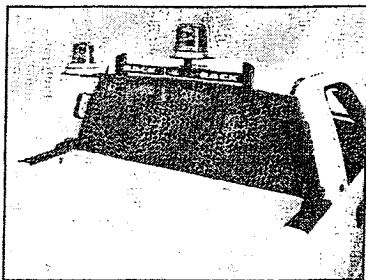

Utility Light Brackets  
Driver's Side (91001)  
Center Mount (91002)

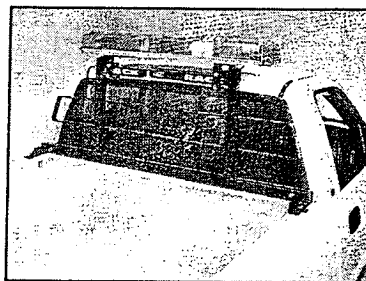

Light Bar Brackets  
(91006)

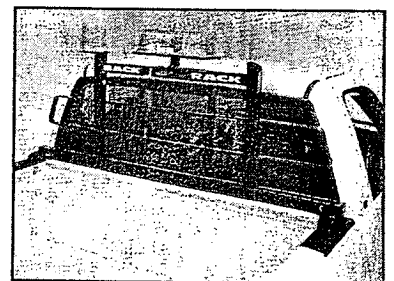

Light Brackets  
Driver's Side 6 1/2" (81001)  
Center 16" x 7" Rectangle (91002R)

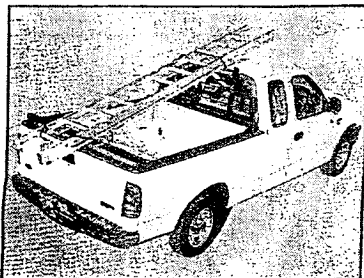

Backrack with accessory Rear Bar

Carry ladders and other long loads on the BACKRACK with or without the accessory REAR BAR. The strength and rigidity of the Backrack allows cargo and shifting loads to be secured safely in the bed of the pickup truck. The No-mesh design makes it easy to use ropes, straps or rubber cords to tie equipment down. The Backrack installs quickly and easily, with no drilling required into the rails on full size pickup trucks.

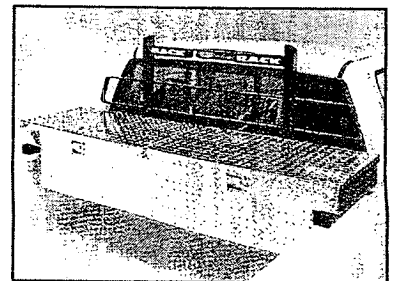

Backrack with Toolbox Brackets

# BACKRACK APPLICATION CHART

PRODUCT: BACKRACK (FRONT RACK)		
PART #	APPLICATIONS	
10501	Ford Fullsize:	1999 - Current - Superduty Only
10502	Ford Fullsize:	1997 - Current - Light/Regular Duty Only
10502SC	Ford Supercrew:	1999 - Current
10503	Chev/GMC Fullsize:	1988 - 98/1999 - Current (Classic Style Only)
10504	Chev/GMC Fullsize:	1968 - 87
	Dodge Fullsize:	1969 - 93
10505	Ford Fullsize:	1975 - 96/1997 Heavy Duty (6 1/2' Bed Only)
10506	Ford Fullsize:	1975 - 96/1997 Heavy Duty (8' Bed Only)
10507	Dodge Fullsize:	1994 - Current
10517	Dodge Ram Fullsize:	2002 - Current (New Body Style)
10508	Toyota Tundra	1999 - Current
10509	Chev/GMC Fullsize:	1999 - Current (New Body Style)
10310	Mazda (to 1993) / Toyota / Dodge Dakota (to 1996)	
10311	Ford Ranger	All Years
	Mazda	1993 - Current
10312	Chev/GM S-Series	1982 - Current
	Nissan	1987 - Current
10313	Dodge Dakota	1997 - Current
10501TB	Part #10501, Complete with Toolbox Brackets	
10502TB	Part #10502, Complete with Toolbox Brackets	
10503TB	Part #10503, Complete with Toolbox Brackets	
10504TB	Part #10504, Complete with Toolbox Brackets	
10506TB	Part #10505/#10506 Complete with Toolbox Brackets	
10507TB	Part #10507, Complete with Toolbox Brackets	
10517TB	Part #10517, Complete with Toolbox Brackets	
10508TB	Part #10508, Complete with Toolbox Brackets	
10509TB	Part #10509, Complete with Toolbox Brackets	
10310TB	Part #10310, Complete with Toolbox Brackets	
10311TB	Part #10311, Complete with Toolbox Brackets	
10312TB	Part #10312, Complete with Toolbox Brackets	
10313TB	Part #10313, Complete with Toolbox Brackets	

PRODUCT: REAR BARS		
PART #	APPLICATIONS	
11501	Ford Full Size	1999 - Current - Superduty Only
11502	Ford Full Size	1997 - Light/Regular Duty Only
11503	Chev/GMC	1988 - 98/1999 - Current (Classic Style Only)
11504C	Chev/GMC Full Size	1968 - 87
11504D	Dodge Full Size	1968 - 93
11506	Ford Full Size	1975- 96/1997 Heavy Duty
11507	Dodge Full Size	1994 - Current
11517	Dodge Ram Fullsize	2002 - Current (NewBody Style)
11509	Chev/GMC Full Size	1999 - Current (NewBody Style)
11310R	Ford Ranger	All Years

ACCESSORY BRACKETS		
PART #	PRODUCT	
91001	Utility Light Bracket	Drivers Side (10 1/2" Base - Octagonal)
91002	Utility Light Bracket	Centre Mount (10 1/2" Base - Octagonal)
91002 REC	Utility Light Bracket	Centre Mount (16" x 7" Rectangle Base)
91003	Utility Light Bracket	Passengers Side (10 1/2" Base-Octagonal)
91004	Arrow Stick Brackets	Pair
91005	Sport Light Brackets	Pair
91006	Light Bar Brackets	Pair
91007	Utility Light Bracket	Drivers & Passenger Side (16" x 7" Base)
91008	Antenna Mount	Fits Drivers/Passengers Side
81001	Light Bracket	Drivers Side (6 1/2" Base)
81003	Light Bracket	Passengers Side (6 1/2" Base)
91010	Toolbox Brackets 21 1/2"	Fits #10503/4/5/6/7/8/9, 10311 Backracks Only
91011	Toolbox Brackets 21 1/2"	Fits #10501 Backrack Only
91012	Toolbox Brackets 21 1/2"	Fits #10502 Backrack Only
91010-C	Toolbox Brackets 21 1/2"	Fits #10310, 312, 313 Backracks Only
91010-31	Toolbox Brackets 31"	Fits #10503/4/5/6/7/8/9, 10311 Backracks Only
91011-31	Toolbox Brackets 31"	Fits #10501 Backrack Only

TTAB – STK, LLC v. BACKRACK, INC.  
Cancellation No. 92049332 – Registration No. 3014986

## **EXHIBIT 18**

# BACKRACK

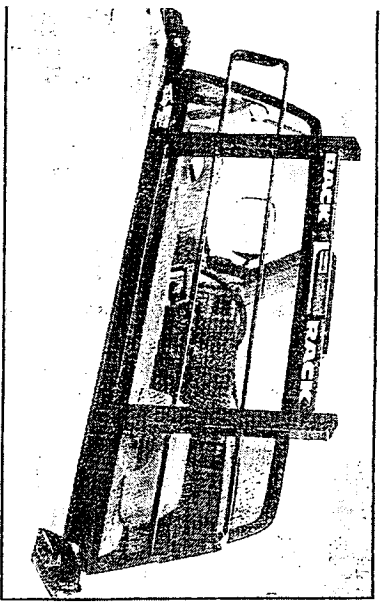

## **A Quality Product That Works on a Pickup Truck**

The Backrack is built from strong, durable steel tubing that is pickled and oiled, which has a smooth finish and provides maximum rust resistance.

The flat bar protecting the rear window of your pickup truck is scale free, and each intersection of material is fully welded for maximum strength.

The Backrack is finished with an attractive and long-lasting black powder coat, and all the fasteners used on the Backrack are plated with zinc dichromate, meeting automakers specifications.

The Backrack provides strength, versatility and style that is not matched by any pickup truck rack or cab guard on the market.

DD333333

# BACKRACK

## **Designed for the Pickup Trucks of Today**

### **EASY TO INSTALL**

The Backrack installs quickly, with no drilling into the rails required on full-size pickup trucks.

### **COMPATIBLE**

Use the Backrack with any bedliner or toolbox you choose to install in your pickup truck.

### **SECURE**

The unique railmount installation system gives the Backrack unequalled strength and rigidity.

### **ATTRACTIVE**

An alternative to full-size racks, the Backrack is always there when you need it and complements the style of today's pickup trucks.

# BACKRACK

**Backrack Inc.  
1-800-265-8137**

Backrack products are designed to assist in securing cargo on pickup trucks. Backrack Inc. has no control over how our products are used, and therefore our warranty is limited to materials and workmanship used in the manufacturing of our products. Backrack is a trademark of Backrack Inc.

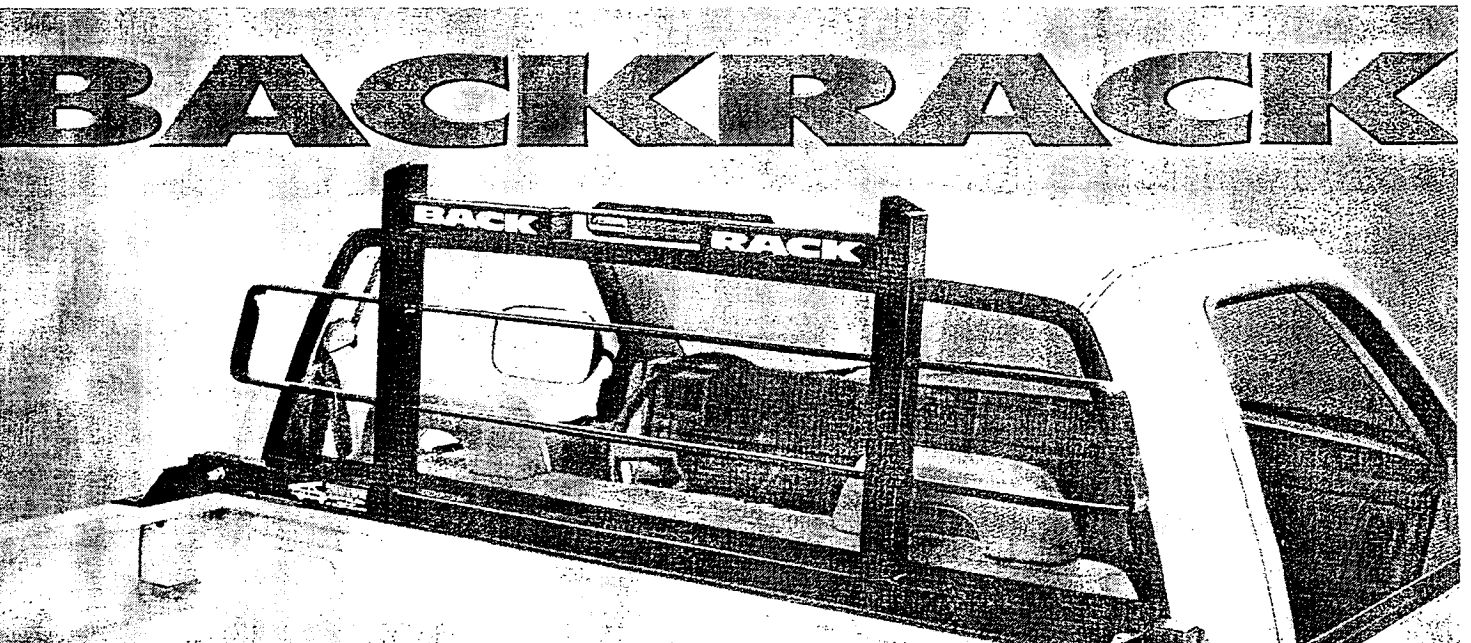

# All the Options Required on a Pickup Truck - A BACKRACK

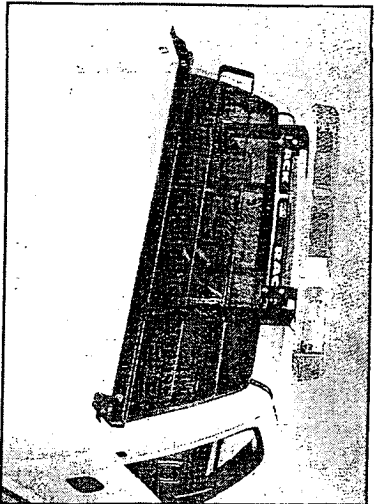

Light Bar Brackets (91086)

## Mount all Types of Warning Lights, Antennas and Accessories on the Backrack

Optional brackets bolt or clamp to the Backrack, eliminating the need to drill holes into the roof of your pickup truck. Why damage your new pickup truck and potentially lower the resale value? Choose the model of light bracket that suits your needs.

## TOOLBOX BRACKETS

**Allow your Cross-bed Toolbox to sit Flush with the Backrack, and Eliminates the Need to Drill into the Pickup Truck Rails when Installing Your Toolbox**

Simply install your toolbox on top of the Toolbox Brackets. Standard Toolbox Brackets are 21 1/2" in length, with 31" brackets to accommodate larger toolboxes available.

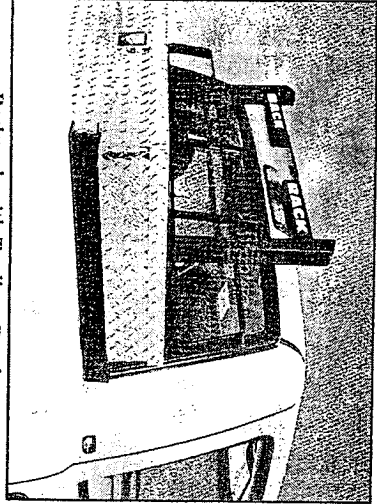

Backrack with Toolbox Brackets

**PROTECT YOUR CAB, and Secure Equipment, Cylinders and Other Heavy Cargo Safely in the Bed of Your Pickup Truck with the Strength and Rigidity Provided only by the BACKRACK**

The no-mesh design is perfect for attaching straps, rope or rubber cords to secure your cargo. Use the accessory Rear Bar for ladders or long, heavy loads. The Rear Bar removes easily, and does not interfere with the tailgate.

# BACKRACK

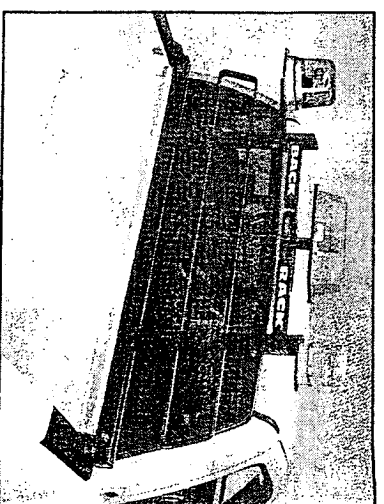

Utility Light Bracket - Driver's Side (91001)  
Utility Light Bracket - Center Rectangle (91002B)  
Light Bracket - Passenger's Side (81005)

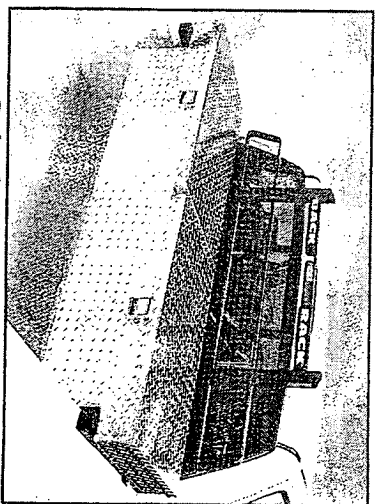

Backrack with Toolbox Brackets

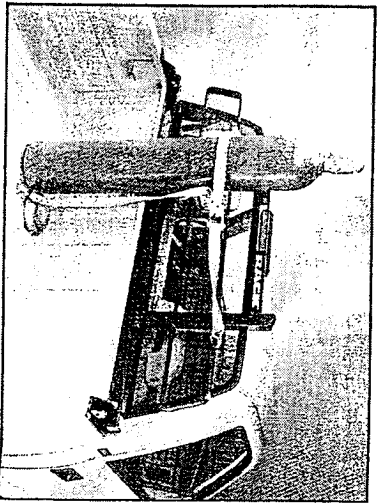

BR00300



TTAB – STK, LLC v. BACKRACK, INC.  
Cancellation No. 92049332 – Registration No. 3014986

## **EXHIBIT 19**

# BACKRACK™

function and style  
for today's trucks

- Easy to install
- No drilling on most trucks
- Durable powdercoat finish
- Many accessories available
- Limited lifetime warranty

## BACKRACK™

### • UNIQUE DESIGN

The BACKRACK™ is unique because it offers excellent function and style for today's trucks. The BACKRACK™ is designed to protect the cab while providing a sturdy structure to secure cargo, carry ladders and mount a unlimited combination of lights, toolboxes, antennas and more. Each rack is custom designed for its specific truck which allows it to blend in with the contours of the rear window. Attention is taken to ensure the driver has optimal rear view and that the rear brake light is visible. From this standpoint the BACKRACK™ is the most safety conscious rack in the market. Our competitors' multi-fit designs simply do not match up. Backracks can be shipped via UPS and most couriers (average 70 Lbs.)

### • CAB PROTECTION

The BACKRACK™ provides good cab protection against personal injury and damage caused by shifting cargo. For this reason alone, it is money well spent. Whether you are outfitting a personal truck or an entire fleet the BACKRACK™ guards against expensive insurance claims and preventable injuries. The BACKRACK™ is a must for any pick-up owner hauling loads that are likely to shift, especially during emergency braking.

### • QUALITY

There is no substitute for steel, especially for work trucks that demand strength and durability. Each BACKRACK™ is manufactured using 1C wall steel tubing and 5/16" flat bar which is robotically welded using 360 degree continuous welds. Each tube end is steel capped and hardened providing superior strength and a meticulous finish.

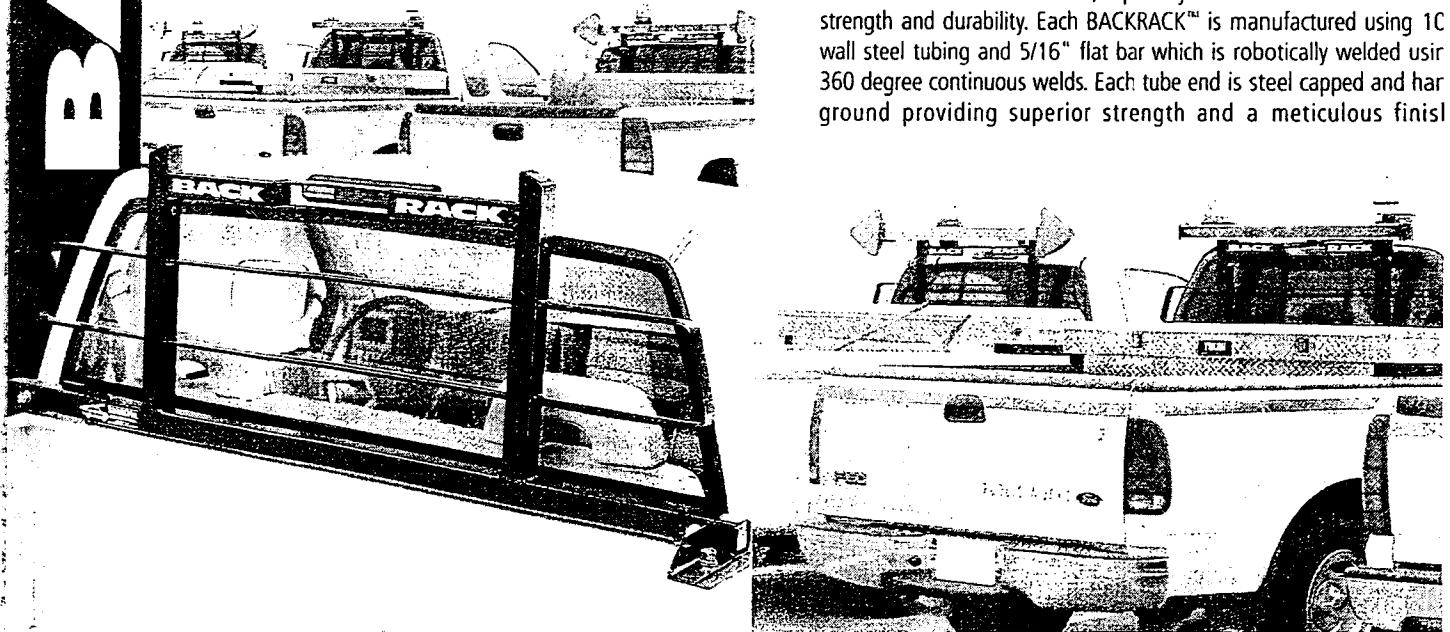

BR00304

## THE ULTIMATE CAB PROTECTION

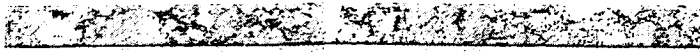

models. It uses the same custom mounting systems as our patented Backracks. The reinforced steel brackets and rail plate system provides the strongest possible stake pocket installation. Each safety rack is finished using our state-of-the-art powder-coat system. Each fastener is yellow zinc plated for maximum corrosion resistance. This attention to detail makes the SAFETY RACK the strongest of its kind on the market.

### MOUNT ACCESSORIES

Like the BACKRACK™, the SAFETY RACK is versatile enough to secure cargo, carry ladders, mount toolboxes and lights. The SAFETY RACK can be mounted in conjunction with most bed liners and rail caps. Each SAFETY RACK can be ordered with 21" or 31" toolbox brackets. The SAFETY RACK can also be used with a REAR BAR to carry longer cargo like pipe and lumber. We also offer a multi-fit light bracket (#41000) which can be used on its own to mount strobes lights, spot lights and antennas. They can also be used in pairs to mount light bars and other accessories. See opposite page for complete accessory bracket listings.

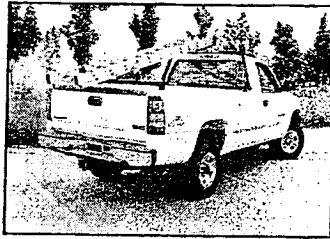

### INSTALLATION

The SAFETY RACK comes in three main sizes; #10200 compact, #10400 full-size and #10300 Super Duty (Ford). Each installation kit is custom designed for each truck model. In most cases, the SAFETY RACK can be mounted without drilling because it uses the stake pockets and specially designed hardware for mounting. Typical installations are performed using conventional automotive shop tools in under 30 minutes. See chart on reverse for specific ordering information.

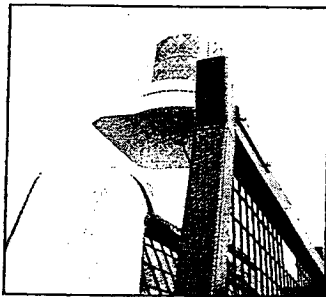

# BACKRACK™

*function and style for today's trucks*

### FUNCTION

- Secure cargo • Carry ladders • Mount lights
- Mount toolboxes • Protect the cab

### STYLE

- Custom designed for each truck model to ensure an attractive appearance
- Patented design blends in with the truck's cab and window contours

### EASY TO INSTALL

- Each is custom designed for each truck model
- Most install in less than 30 minutes with no-drilling

### ACCESSORY FRIENDLY

- More than 30 accessory brackets available
- Most brackets are "no-drill"
- Can be installed with bed liners
- 21" and 31" toolbox brackets available

### QUALITY

- Steel construction: accept no substitutes
- Durable powder coat finish
- Flawless robotic welding
- Yellow zinc plated fasteners

### SHIPPABLE

- Can be shipped via most couriers including UPS
- Excellent packaging - less than 1% courier return rate
- Rack carton dimensions 72" x 26" x 2.5"
- Average weight 70 lbs.

[www.backrack.com](http://www.backrack.com)

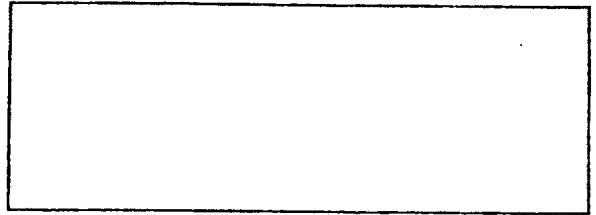

Backrack products are designed to assist in securing cargo on pickup trucks. Backrack Inc. has no control over how our products are used, and therefore our warranty is limited to materials and workmanship used in the manufacturing of our products. Safety Rack is a trademark of Backrack Inc. Backrack does not warranty the powder coat finish on our products.

## function and style for today's trucks

BACKRACK™ products are blasted and power washed in preparation for powder coating. Our powder coat facility uses the latest state-of-the-art technology which produces an impressive, high gloss finish.

### ◆ EASY INSTALLATION

Each BACKRACK™ mounting system is custom designed for each vehicle. The BACKRACK™ has a reinforced bracket system that uses the vehicles' stake pockets to install. In most cases, Backracks do not require drilling to install. Each installation kit includes powder coated mounting brackets and yellow zinc coated fasteners for maximum strength and corrosion resistance. Reinforcing rail plates are also provided to increase the strength of the bed rails beneath the mounting brackets. As you might expect, BACKRACK™ goes the extra mile by including polypropylene strips to protect the vehicle's finish prior to installation. Mounting brackets have oblong holes providing easy adjustments when mounting. Most Backracks install in under 30 minutes using Conventional shop tools. See chart on reverse for specific ordering information.

### ◆ ACCESSORY FRIENDLY

One major reason Backracks are so popular with fleets is because they are accessory friendly. Holes are pre-punched in each upright to allow no-drill mounting for many available brackets. Backracks can be installed with most bed liners and toolboxes. We have brackets to mount virtually any kind of strobe, light bar, arrow stick, antenna or toolbox in multiple configurations. See opposite page for a selection of more than 30 accessory brackets to choose from.

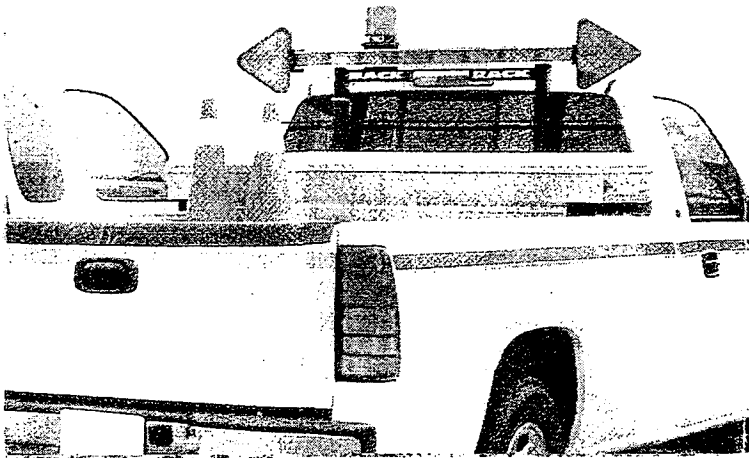

## SAFETY RACK

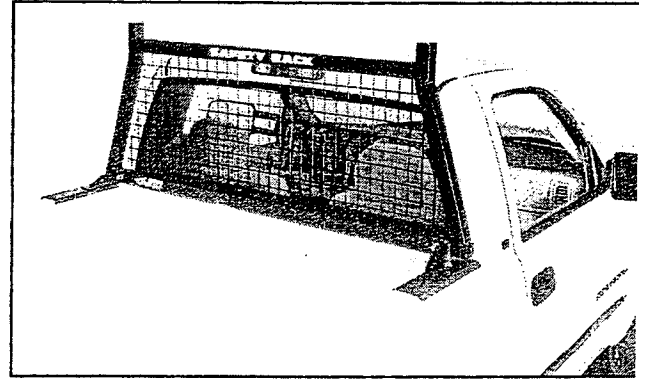

### ◆ SAFETY FIRST

The Safety Rack uses a conventional mesh screen design that is built the hard core work truck. It offers the best protection against preventa damage and injuries caused during loading and emergency situatio The SAFETY RACK is specifically designed to protect the cab better th any other rack on the market. It is a best suited for for use on w trucks that carry construction materials, equipment and other dangerc cargo. Even when cargo is properly secured, emergency braking, a collisions can cause cargo to shift and pose serious risk to the cab a occupants. In these situations, the SAFETY RACK is your first line defense. This translates into fewer insurance claims and personal injuri Of course, the SAFETY RACK is also functional enough to carry ladd mount toolboxes, and lights as well.

### ◆ STRENGTH AND DURABILITY

The SAFETY RACK uses a sturdy 100 wall, 2" steel tube frame design with a custom cut steel mesh inlay which is robotically welded in place. The mesh has a cutout to ensure the rear brake light is visible. It's rugged steel design is much stronger than any of our competitors

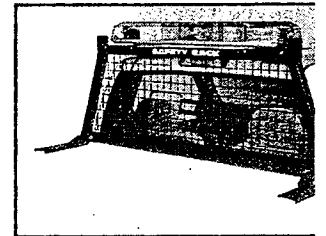

TTAB – STK, LLC v. BACKRACK, INC.  
Cancellation No. 92049332 – Registration No. 3014986

## **EXHIBIT 20**

**BACKRACK™**  
FUNCTION AND STYLE FOR TODAY'S TRUCKS

**BACKRACK™**  
FUNCTION AND STYLE FOR TODAY'S TRUCKS

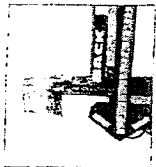

81003 Driver Side  
81003 Passenger Side  
6-1/2" Oregon Bars



91001 Driver Side  
91002REC Center Rec.  
91003 Passenger Side  
10-1/2" Oregon Bars



91001F Driver Side  
91002REC Center Rec.  
91003 Passenger Side  
Folds down 180°



91004 Adaptor  
to most arrow racks. Comes with  
4 self-tap screws. Can also be  
used with Safety Rack.



91002REC Center  
91007 D & P Side Mount  
16" x 7" Rectangle Base



91006 Two 1" Buckets (pr)  
Adapts to most light bars



91005 Up/L Brks 7/16" brks  
for stair mount



91008 Mount rack  
3.5" x 3.5" mount surface with  
7/8" pre-drilled hole  
No drilling required



41000 Bull to mount on  
Safety Rack, 10.5" x 10.5" mount  
surface. Self-tap screws included.  
Two can be paired to mount a  
variety of accessories and lights.

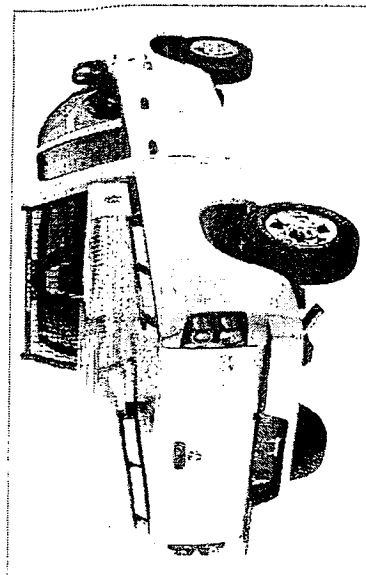

BR00282

THE BRAND NAME  
YOU TRUST

Available from:

800-265-8137 [backrack.com](http://backrack.com)

BACKRACK & SAFETY RACK

# BACKRACK™

## FUNCTION AND STYLE FOR TODAY'S TRUCKS

### TOUGH CONSTRUCTION:

The strength of a BACKRACK begins with rigid materials. Heavy gauge 2" tubing is robotically welded at each intersection, and all tube ends are robotically welded then polished for a finished look. All tubes, flat bar and flat steel are scale free Pickled & Oiled material for minimal corrosion.

### DURABLE POWDER COAT FINISH:

All BACKRACK products are powder coated in our factory using our state-of-the-art powder coat line. The four-stage pre-treatment process prepares a flexible surface on which to apply the powder. Our digitally controlled automatic application equipment provides a smooth and consistent application of powder for a durable, consistent and attractive finish.

### ADAPTABLE TO YOU BUSINESS:

Securing cargo to your BACKRACK is safe and easy. The open design allows for hooks, straps and ropes to be easily attached

to the frame. Our accessories simply bolt on to customize your BACKRACK to whatever you need it to be. For example, the REAR BAR makes your BACKRACK an inexpensive and flexible ladder rack. Our LIFT-IT BRACKETS allow you to mount virtually any type of light without drilling holes in your truck. See the Accessories section for a full listing.

### SIMPLE INSTALLATION:

Each BACKRACK is engineered to tighten securely in the truck's stake pockets, and install in minutes. Installation requires no drilling on the majority of trucks, and each BACKRACK is compatible with over the rail and under the rail bed liners as well as spray in liners.

### STYLISH DESIGN:

Function and Style for today's truck. Keeps your truck looking great while providing all the utility you need to get the job done.

### BUILT TOUGH:

With a heavy gauge 2" tubular frame surrounding a 3/16" welded wire screen insert, the SAFETY RACK is the toughest rack guard available. Like the BACKRACK, all steel is scale free Pickled & Oiled material for maximum corrosion resistance. The screen insert is spot welded at each intersection then robotically welded into the frame. SAFETY RACK is powder coated with the same care and quality as the BACKRACK.

### BUILT SAFE:

Full screen coverage of the rear window protects both the truck cab and its occupants. In today's world of strict safety standards, SAFETY RACK offers you and your organization the comfort of knowing that your assets are protected. Visibility of the third brake light is maintained with a cut away section in the screen.

### BUILT SOLID:

The strength of both SAFETY RACK and BACKRACK is in our mounting system. Each mounting system is designed specifically for each truck, allowing for the installation of our racks without drilling holes on most models. Two types of mounts are available: the standard RAILMOUNT BRACKETS, or the TOOLBOX BRACKETS that allow for the installation of a cross bar toolbox without drilling. Why drill holes in your truck if you don't have to?

### BUILT FOR WORK:

Get the job done confidently with SAFETY RACK. The low profile design lets you comfortably park in your garage and access underground parking. The multi use # 41000 Light Bracket accessory provides a base to mount numerous lights and accessories. The REAR BAR accessory turns the SAFETY RACK into an inexpensive ladder rack.

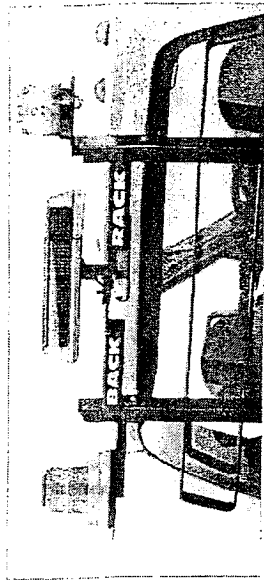

### MOUNT LIGHTS WITHOUT DRILLING HOLES

Don't bolt it through the roof! BACKRACK has a built on accessory bracket that will prevent almost anything you can think of adding to your truck.

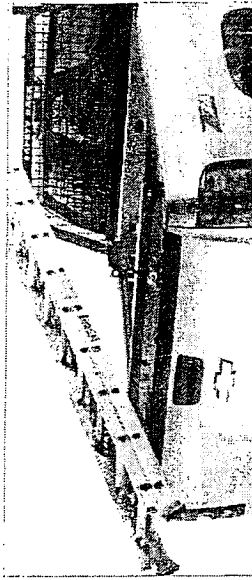

### REAR BAR MAKES CARRYING LADDERS EASY

Our REAR BAR accessory simply drops into the rear stake holes of your truck. Simply remove it and store it when not needed. An inexpensive alternative to unsightly, full size ladder racks.

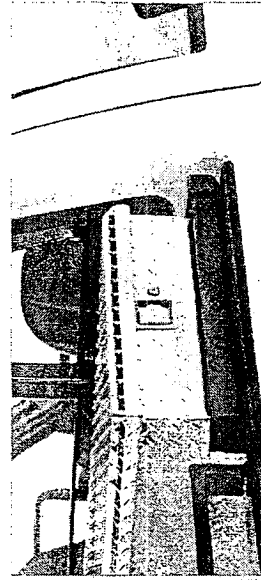

### TOOLBOX BRACKETS

Toolbox brackets can be ordered with your BACKRACK when you purchase by specifying "TB" after the part number when ordering (ie. 10519 TB). If you wish to add them after your purchase, they are sold separately but without fasteners.

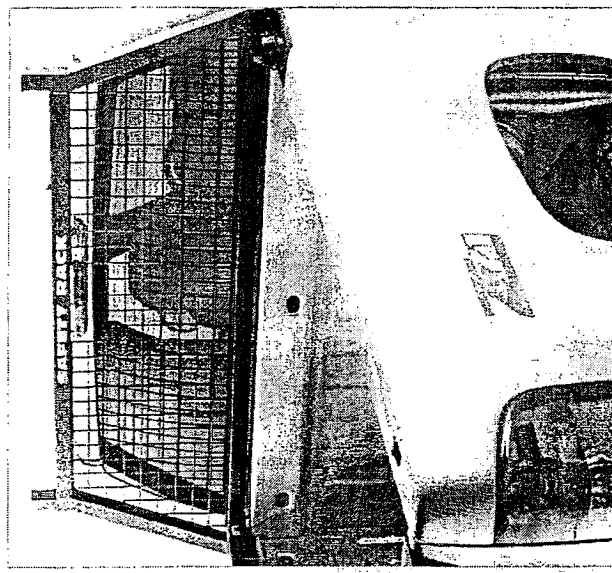
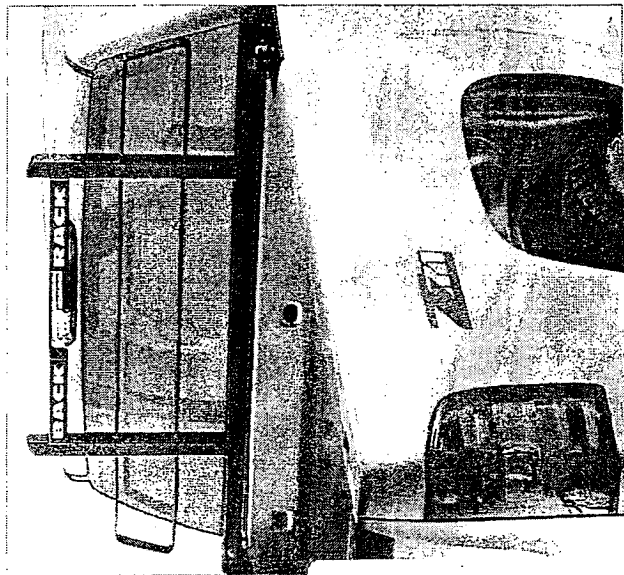

BR00283

MRKT007

TTAB – STK, LLC v. BACKRACK, INC.  
Cancellation No. 92049332 – Registration No. 3014986

## **EXHIBIT 21**





# BACKCRACK™

FUNCTION AND STYLE FOR TODAY'S TRUCKS

## SIDERAILS

### NO DRILL INSTALLATION:

BACKCRACK SIDERAILS are engineered to custom fit each individual truck bed. Our Stake Pocket Bolt installation system is designed to allow the Stake Rails to simply drop into the stake holes and tighten down firmly using a simple ratchet. Our custom fit and no drill installation separates our product from our competitors.

### NORTH AMERICAN QUALITY:

Every BACKCRACK product is engineered, manufactured, powder coated and packaged in our Oakville, Ontario plant. To build a consistent quality product, you need constant supervision of all processes. Outsourcing our manufacturing is simply not an option. Our steel is bought direct from North American manufacturers, to ensure quality. Absorbing the North American worker to make a quick profit is not part of BACKCRACK'S culture.

### SIMPLE INSTALLATION:

Drop them on and bolt them in. It's almost that simple. Once you secure the custom Stake Pocket Bolt into the stake holes, the SIDERAILS drop into the pockets over the bolts. Turn down the nut with a ratchet, and finish the installation by inserting the plastic caps inside the stake holes to tuck all the fasteners. Very slick.

**SERIOUS STRENGTH:** Unlike other rails, BACKCRACK SIDERAILS aren't designed just to be pretty. They are designed for kind of abuse our racks take every day. Heavy gauge HRPO steel tube is robotically welded at each intersection for maximum strength, and the tube rail is welded to an 11 gauge steel angle base that runs the full length of your truck bed, allowing you to secure your load with confidence.

**TOOLBOX FRIENDLY:** BACKCRACK SIDERAILS are available for both 6.5 ft and 8 ft bed lengths. The Tube Rail is available in two configurations: The FULL RAIL, which extends the full length of the truck bed and the TOOLBOX RAIL, where the Tube Rail stops short to accommodate the insertion of a cross bed toolbox.

**STYLISH GOOD LOOKS:** Who said strong has to be ugly? We designed our SIDERAILS to complement the great looks of our BACKCRACK and SAFETY RACK. The angled uprights and submerged fasteners give these rails a finished look that will look great, even if you never use your truck for work.

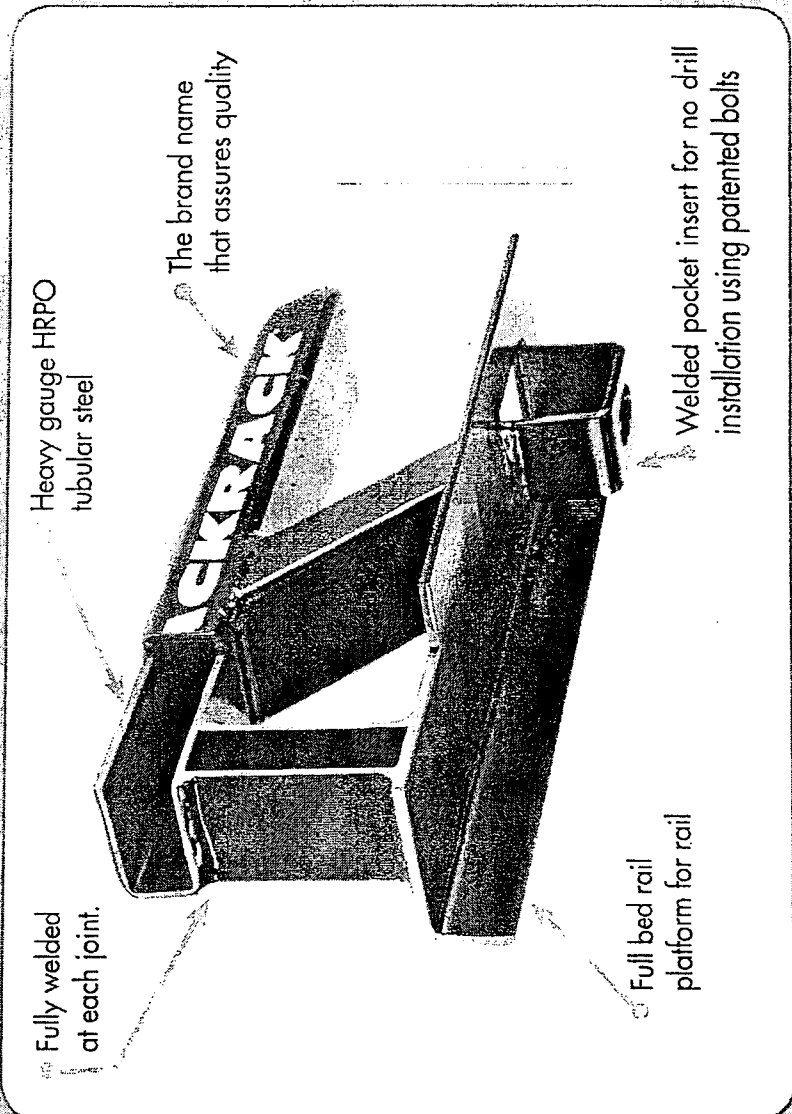
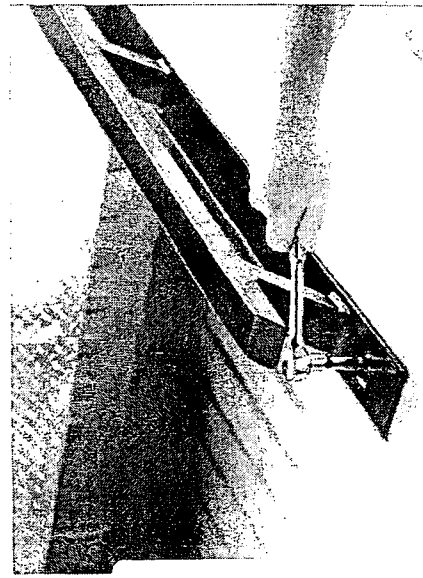
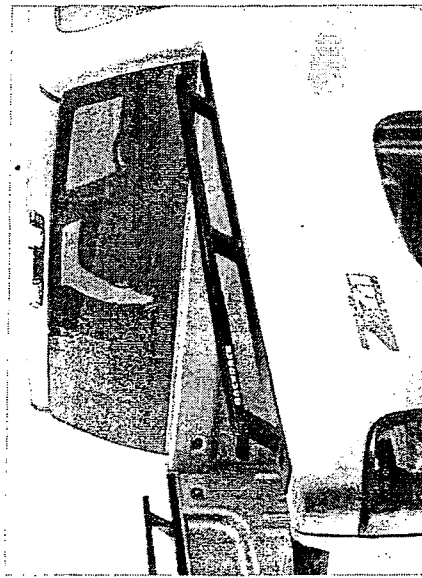

BR00285

MR17006

TTAB – STK, LLC v. BACKRACK, INC.  
Cancellation No. 92049332 – Registration No. 3014986

## **EXHIBIT 22**

# BACKRACK™

FUNCTION AND STYLE FOR TODAY'S TRUCKS

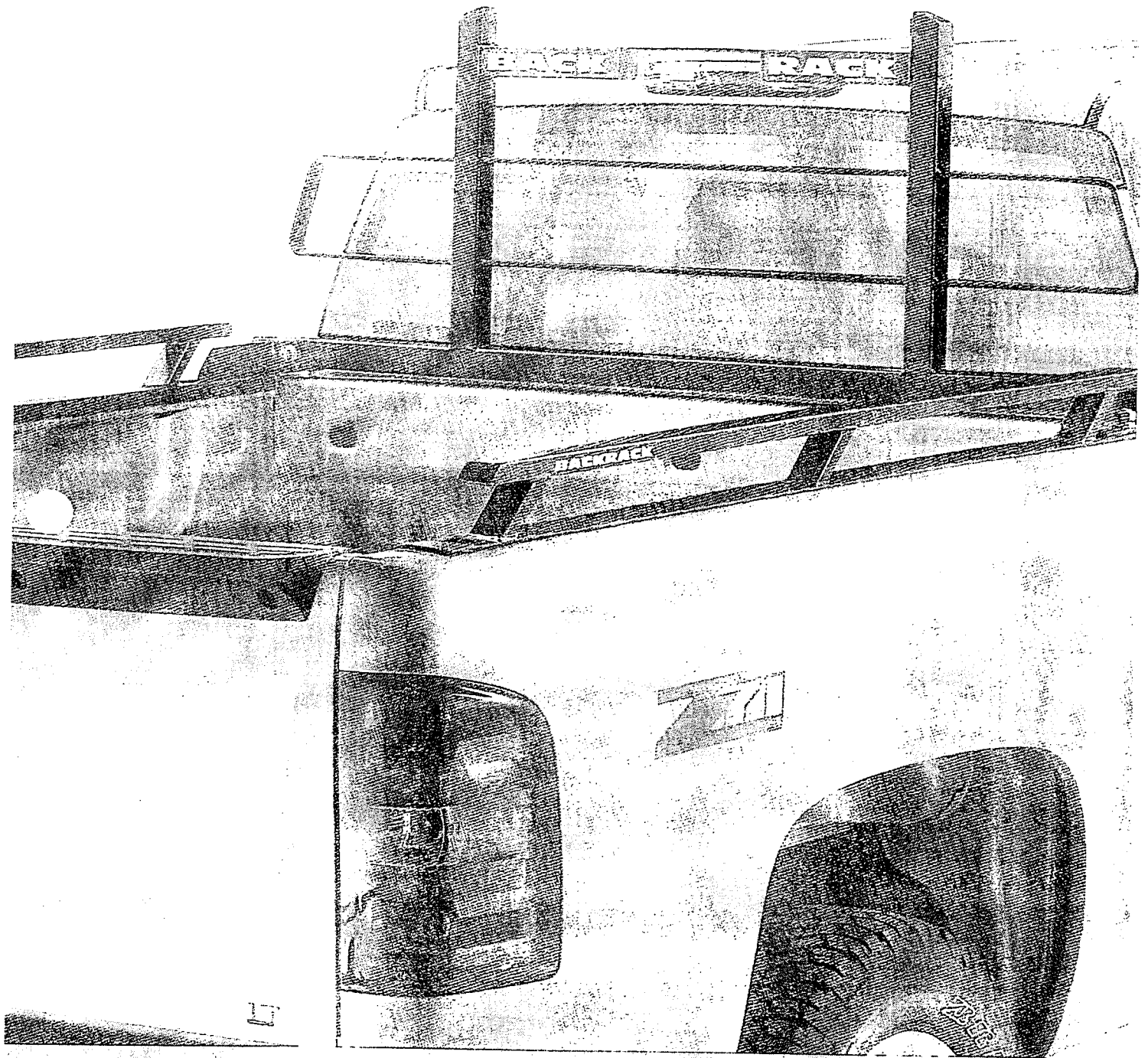

BR00286

**BUILT TOUGH:** With a heavy gauge 2" tubular frame surrounding a 3/16" welded wire screen insert, the SAFETY RACK is the toughest cab guard available. Like the BACKRACK, all steel is scale free Pickled & Oiled material for maximum corrosion resistance. The screen insert is spot welded at each intersection then robotically welded into the frame. SAFETYRACK is powdered coated with the same care and quality as the BACKRACK.

**BUILT SAFE:** Full screen coverage of the rear window protects both the truck cab and its occupants. In today's world of strict safety standards, SAFETYRACK offers you and your organization the comfort of knowing that your assets are protected. Visibility of the third brake light is maintained with a cut away section in the screen.

**BUILT SOLID:** The strength of both SAFETYRACK and BACKRACK is in our mounting system. Each mounting system is designed specifically for each truck, allowing for the installation of our racks without drilling holes on most models. Two types of mounts are available: the standard RAILMOUNT BRACKETS, or the TOOLBOX BRACKETS that allow for the installation of a cross bed Toolbox without drilling. Why drill holes in your truck if you don't have to?

**BUILT FOR WORK:** Get the job done confidently with SAFETYRACK. The T-bar profile design lets you comfortably park in your garage and access underground parking. The multi use # 41000 Light Bracket accessory provides a base to mount numerous lights and accessories. The REAR BAR accessory turns the SAFETY RACK into an inexpensive ladder rack.

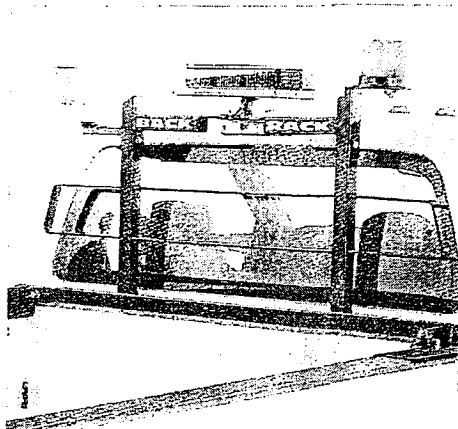
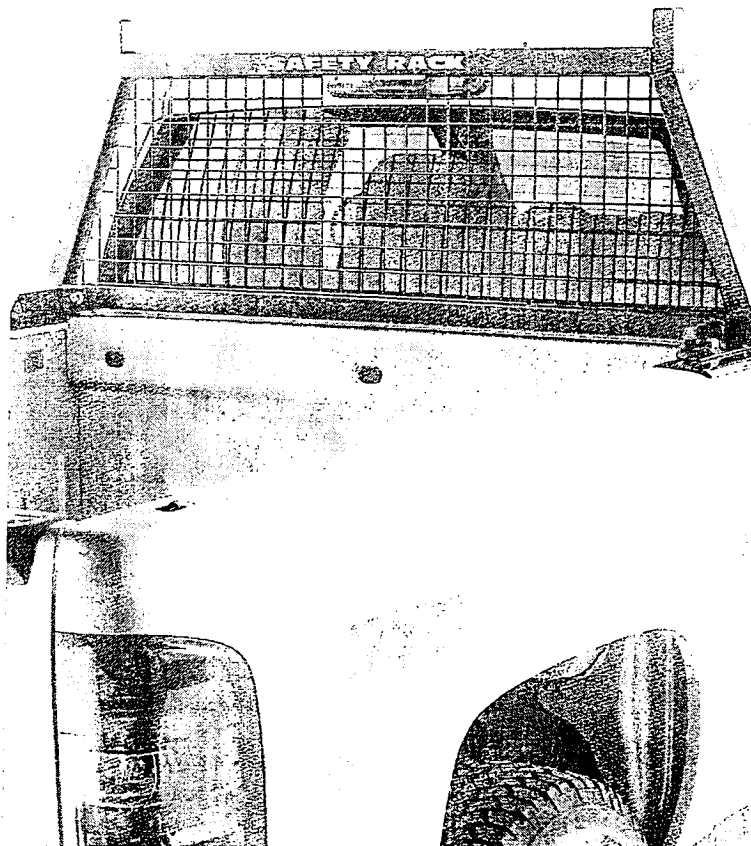

**MOUNT LIGHTS  
WITHOUT DRILLING HOLES**

Mount your lights through the roof! BACKRACK has a built-in accessory bracket that will mount almost anything you can think of adding to your truck.

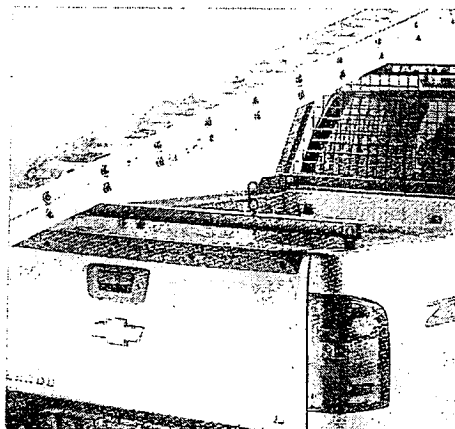

**REAR BAR MAKES  
CARRYING LADDERS EASY**

Our REAR BAR accessory simply drops into the rear stake holes of your truck. Simply remove it and store it when not needed. An inexpensive alternative to unsightly full-size ladder racks.

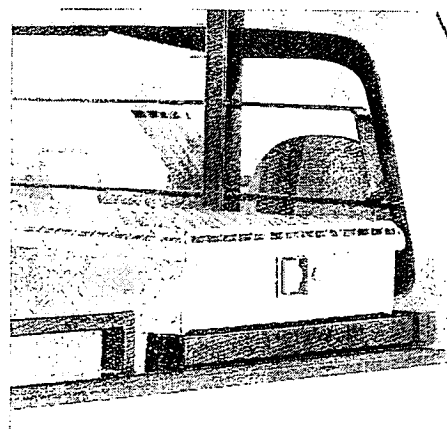

**TOOLBOX BRACKETS**

Toolbox Brackets can be ordered with your BACKRACK when you purchase by specifying "T" after the part number when ordering. (i.e. 105 TB). If you wish to add them after your purchase they are sold separately but without fasteners.

# BACKRACK™

FUNCTION AND STYLE FOR TODAY'S TRUCKS

Why settle for less? We're not satisfied with universal mounting systems that require drilling holes, and neither should you be. Wherever possible, we engineer our products to fasten onto your truck without drilling holes. This is what separates BACKRACK from our competitors.

Every BACKRACK product is engineered, manufactured, powder coated and packaged in our Oakville, Ontario plant. To build a consistent quality product, you need constant supervision of all processes. Outsourcing our manufacturing is simply not an option. Our steel is bought direct from North American manufacturers to ensure quality. Abandoning the North American worker to make a quick profit is not part of BACKRACK's culture.

Twenty years ago, we made our first BACKRACK. Twenty years later, the same man still owns the company and, on occasion, still gets his hands dirty in the shop. When a business owner is personally invested and involved in the day-to-day operation of a business, the result is a quality product created by caring employees. Our manufacturing processes are modern; our commitment to quality is old school.

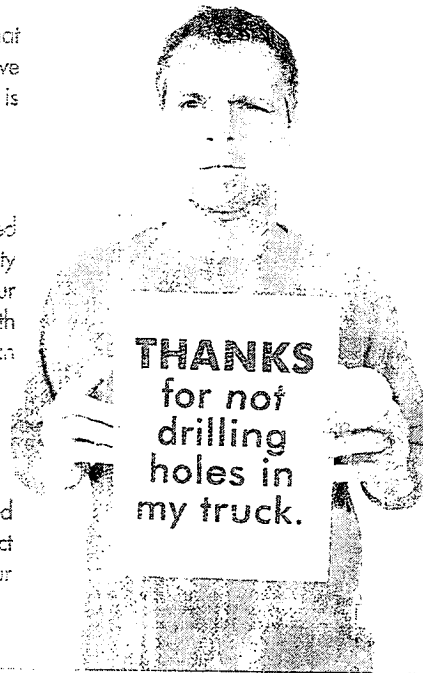

THANKS  
for not  
drilling  
holes in  
my truck.

THE BRAND NAME  
YOU TRUST

**TOUGH CONSTRUCTION:** The strength of a BACKRACK begins with rigid materials. Heavy gauge 2" tubing is robotically welded at each intersection, and all tube ends are robotically welded then polished for a finished look. All tube, flat bar and flat steel are scale free Pickled & Oiled material for minimal corrosion.

**DURABLE POWDER COAT FINISH:** All BACKRACK products are powder coated in our factory using our state-of-the-art powder coat line. The five-stage pre-treatment process prepares a flawless surface on which to apply the powder. Our digitally controlled automatic application equipment provides a smooth and consistent application of powder for a durable, consistent and attractive finish.

**ADAPTABLE TO YOU BUSINESS:** Securing cargo to your BACKRACK is safe and easy. The open design allows for hooks, straps and rope to be easily affixed to the frame. Our accessories simply bolt on to customize your BACKRACK to whatever you need it to be. For example, the REAR BAR makes your BACKRACK an inexpensive and flexible Ladder Rack. Our LIGHT BRACKETS allow you to mount virtually any type of light without drilling holes in your truck. See the Accessories section for a full listing.

**SIMPLE INSTALLATION:** Each BACKRACK is engineered to fasten securely in the truck's stake pockets, and install in minutes. Installation requires no drilling on the majority of trucks, and each BACKRACK is compatible with over the rail and under the rail bed liners as well as spray in liners.

**STYLISH DESIGN:** Function and Style for today's truck. Keeps your truck looking great while providing all the utility you need to get the job done.

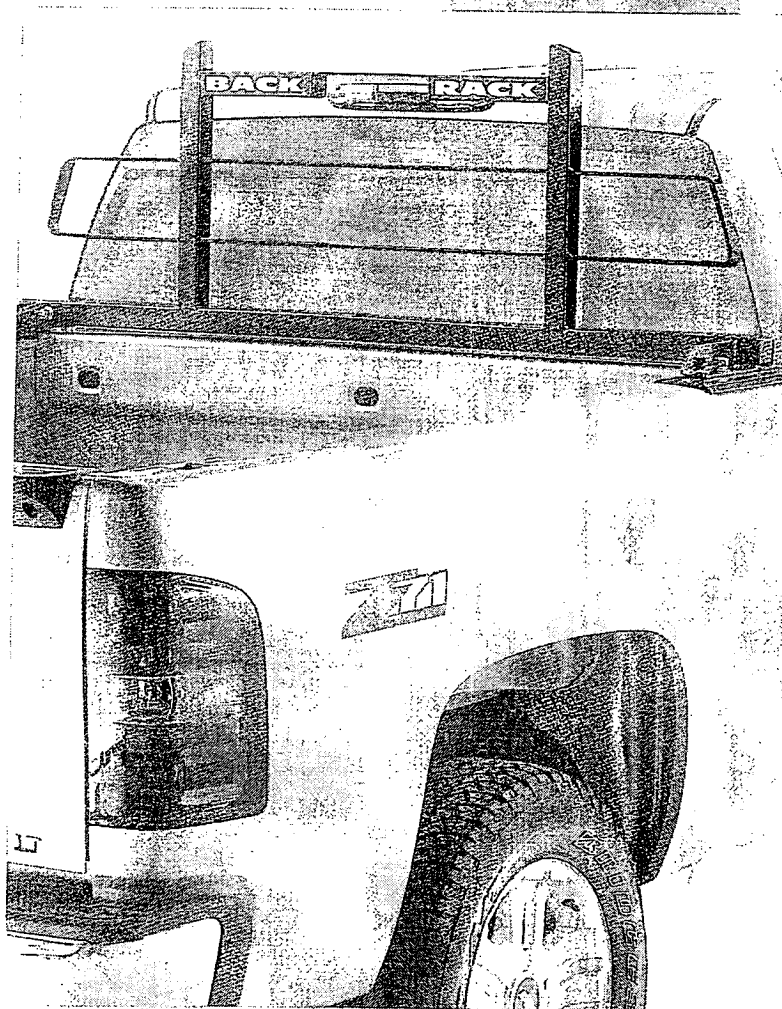

# BACKRACK™

## FUNCTION AND STYLE FOR TODAY'S TRUCKS

**NO DRILL INSTALLATION:** BACKRACK SIDERAILS are engineered to custom fit each individual truck bed. Our Stake Pocket Bolt installation system is designed to allow the Side Rails to simply drop into the stake holes and fasten down firmly using a simple ratchet. Our custom fit and no drill installation separates our product from our competitors.

**NORTH AMERICAN QUALITY:** Every BACKRACK product is engineered, manufactured, powder coated and packaged in our Oakville, Ontario plant. To build a consistent quality product, you need constant supervision of all processes. Outsourcing our manufacturing is simply not an option. Our steel is bought direct from North American manufacturers to ensure quality. Abandoning the North American worker to make a quick profit is not part of BACKRACK's culture.

**SIMPLE INSTALLATION:** Drop them on and bolt them in. It's almost that simple. Once you secure the custom Stake Pocket Bolts into the stake holes, the SIDERAILS drop into the pockets over the bolts. Turn down the nuts with a ratchet, and finish the installation by inserting the plastic caps inside the stake holes to hide all the fasteners. Very slick.

**SERIOUS STRENGTH:** Unlike other rails, BACKRACK SIDERAILS aren't designed just to be pretty. They are designed for the kind of abuse our racks take every day. Heavy gauge HRPO steel tube is robotically welded at each intersection for maximum strength and the tube rail is welded to an 11-gauge steel angle base that runs the full length of your truck bed, allowing you to secure your load with confidence.

**STYLISH GOOD LOOKS:** Who said strong has to be ugly? We designed our SIDERAILS to compliment the great looks of our BACKRACK and SAFETY RACK. The angled uprights and submerged fasteners give these rails a finished look that will look great, even if you never use your truck for work.

**TOOLBOX FRIENDLY:** BACKRACK SIDERAILS are available for both 6.5 ft and 8 ft bed lengths. The Tube Rail is available in two configurations: the FULL RAIL, which extends the full length of the truck bed and the TOOLBOX RAIL, where the Tube Rail stops short to accommodate the insertion of a cross bed Toolbox.

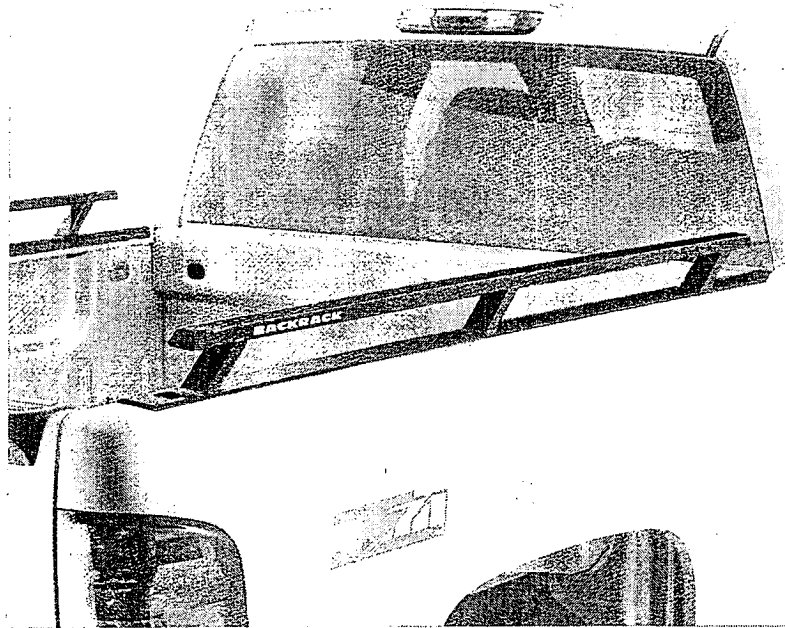

Fully welded at each joint.

Heavy gauge HRPO tubular steel

The brand name that assures quality

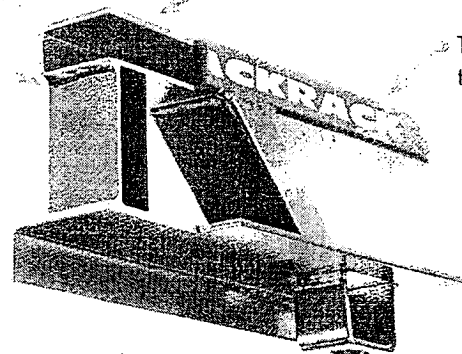

Full bed rail platform for rail

Welded pocket insert for no drill installation using patented bolts

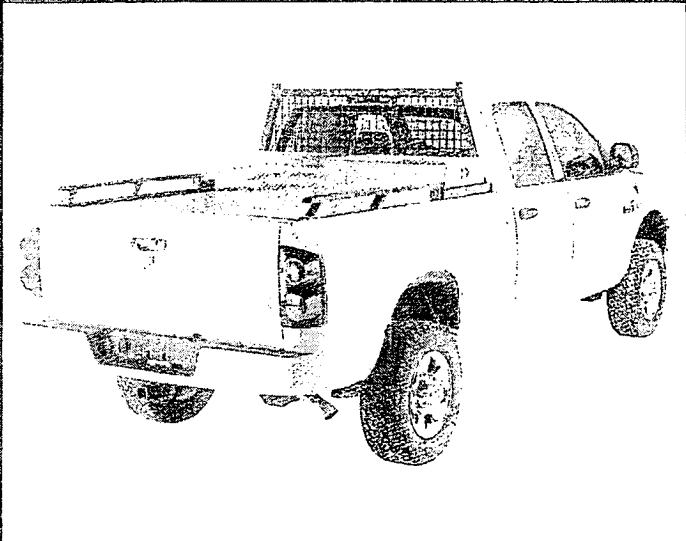
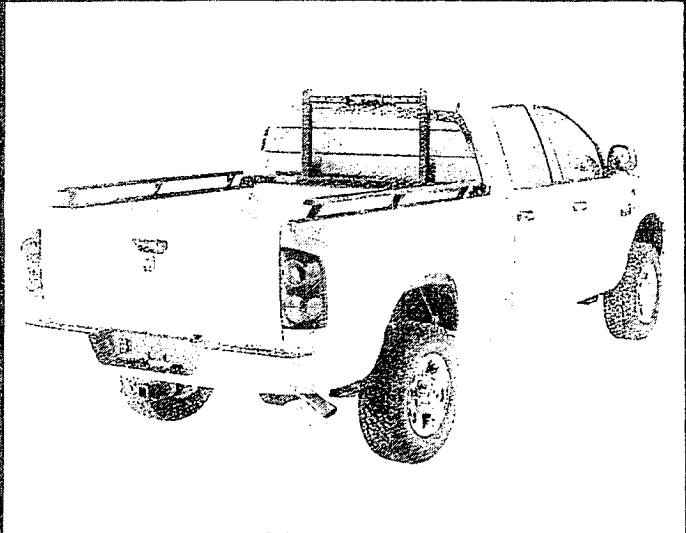
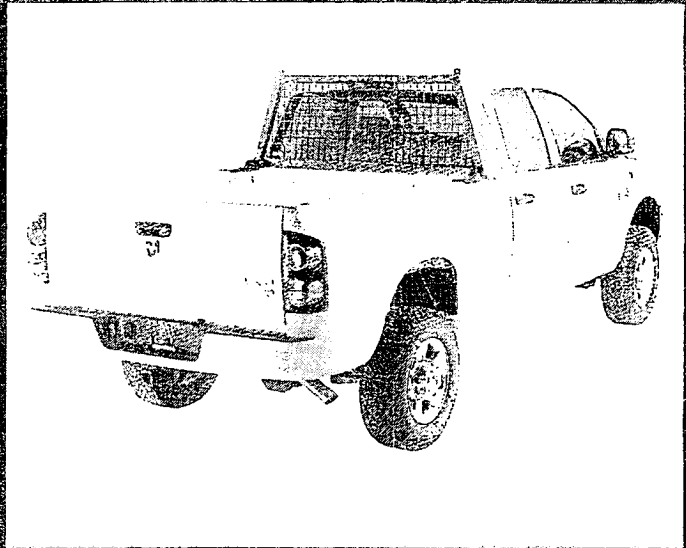

BR00290

**BACKRACK™**  
FUNCTION AND STYLE FOR TODAY'S TRUCKS



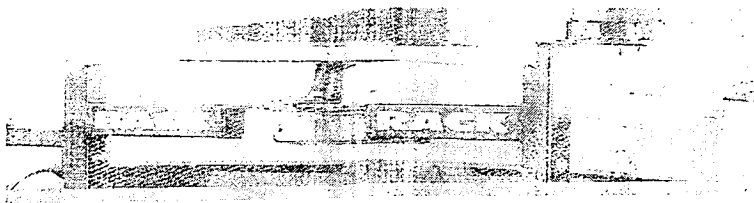

91006

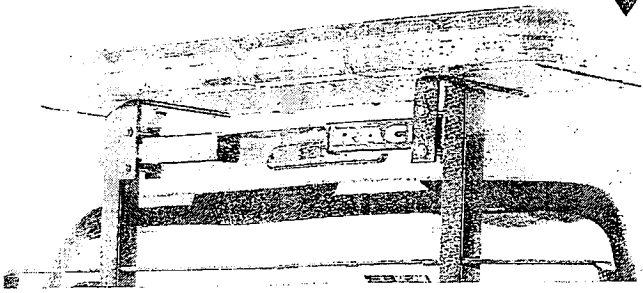

91007, 91004, 91005

91002 REC

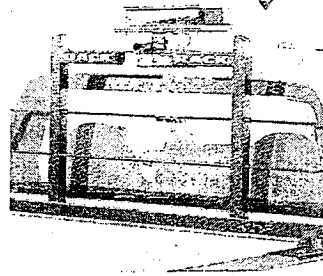
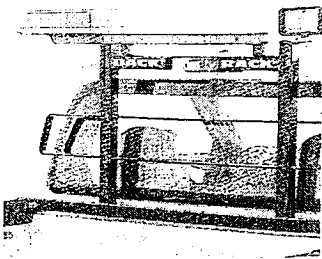

91005

91008

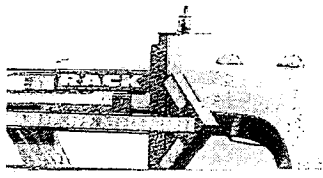
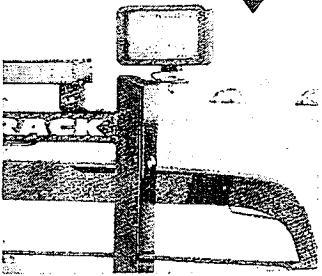

91003

91002 REC F

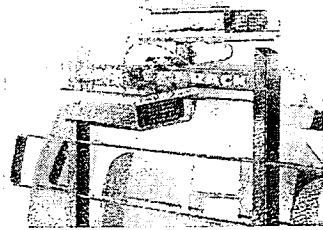
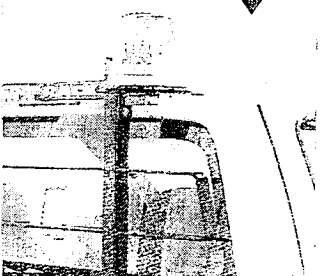

81001

41000

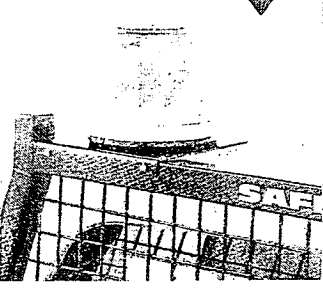
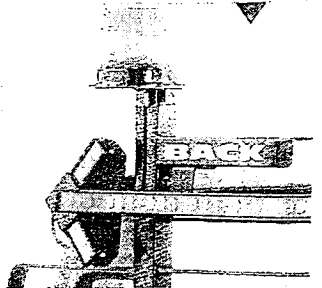

TTAB – STK, LLC v. BACKRACK, INC.  
Cancellation No. 92049332 – Registration No. 3014986

## **EXHIBIT 23**

# BACKRACK™

*function and style for today's trucks*

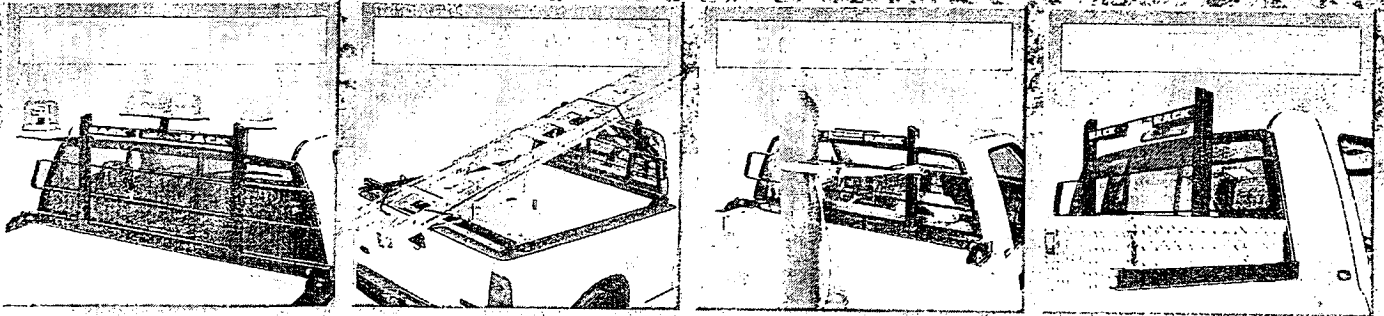

## PRODUCT GUIDE

- Easy to install
- No drilling on most trucks
- Durable powdercoat finish
- Many accessories available
- Limited lifetime warranty

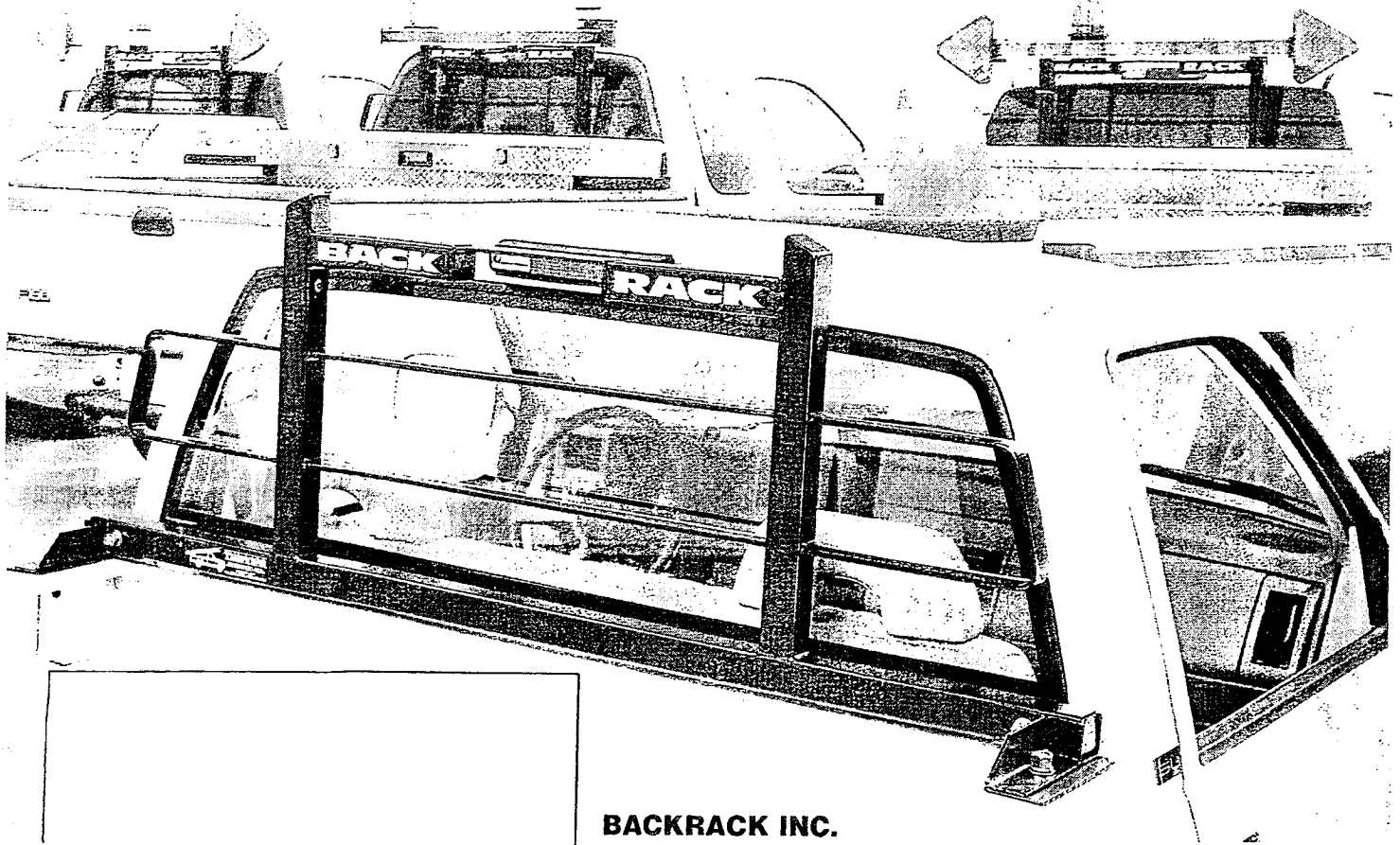
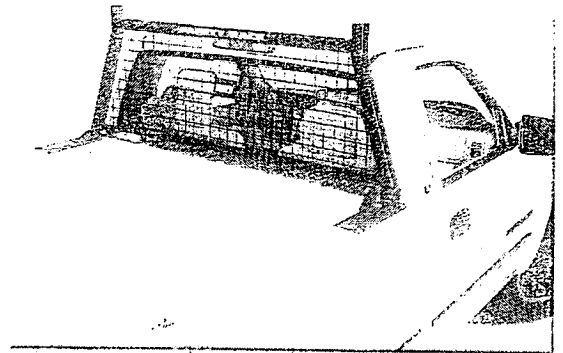

**BACKRACK INC.**

800-888-8888

# BACKRACK™

*function and style for today's trucks*

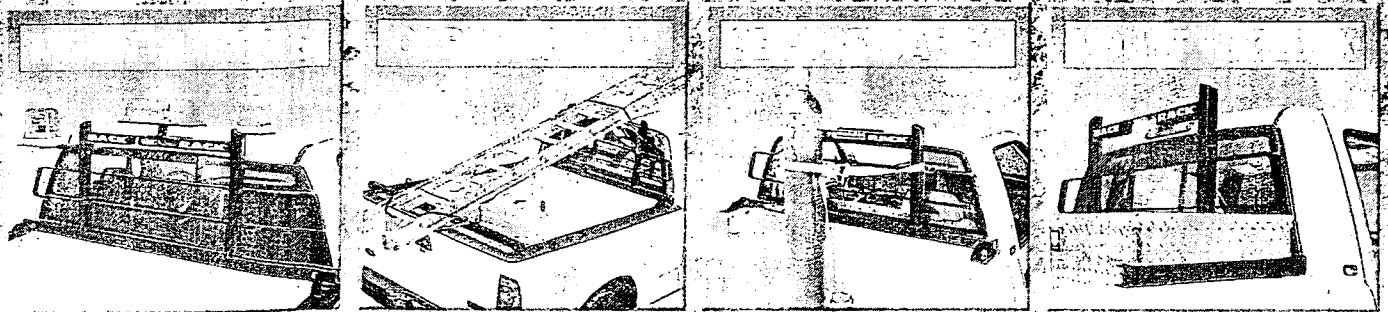

## 2004 PRICE LIST

- Easy to install
- No drilling on most trucks
- Durable powdercoat finish
- Many accessories available
- Limited lifetime warranty

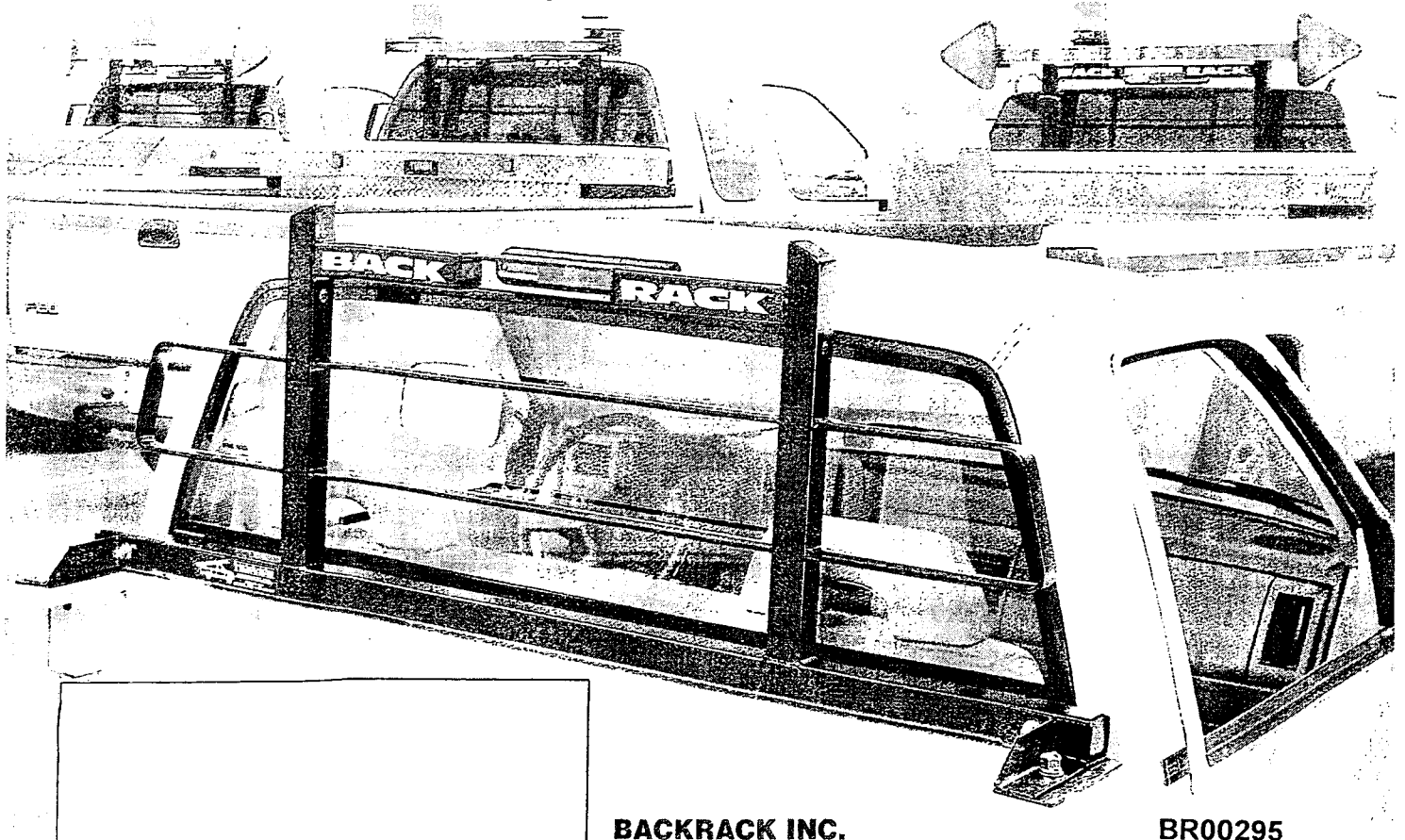
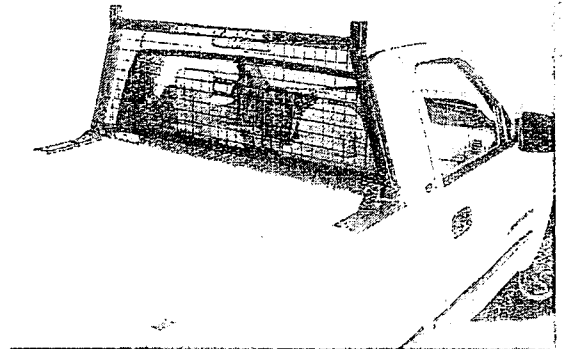

BACKRACK INC.

BR00295

# BACKRACK™

## 6.5" Round

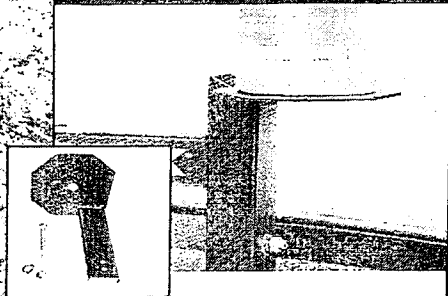

81001 Driver Side  
81003 Passenger Side  
No drilling required

## 10.5" Round

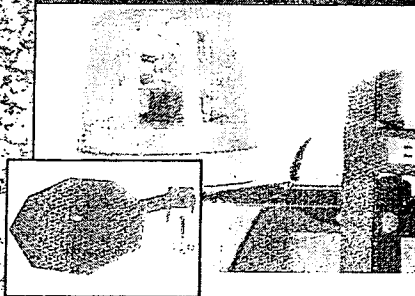

91001 Driver Side  
91002 Center Mount  
91003 Passenger Side  
No drilling required

## 10.5" Round - folding

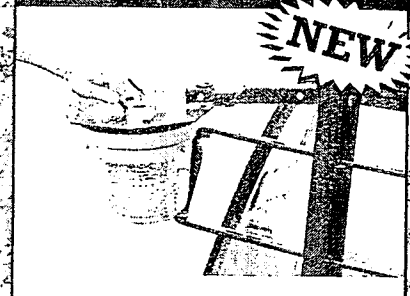

91001F Driver Side  
91003F Passenger Side  
Rotates 180 degrees  
No drilling required

## Arrow Stick

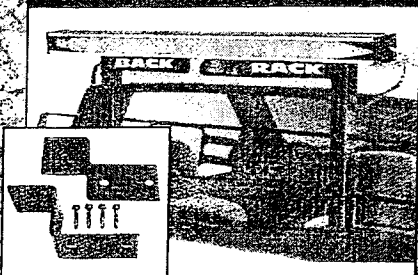

91004 Adapts to most arrow sticks.  
Comes with 4 self-tap screws.  
Can also be used with  
Safety Rack.

## 16" x 7" Rectangular

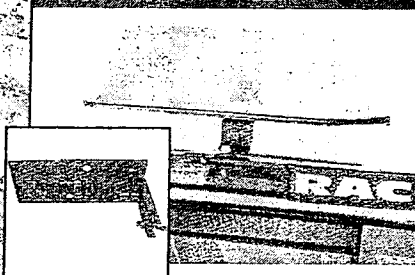

91002REC Center Mount  
91007 Side Mount  
No drilling required

## Light Bar

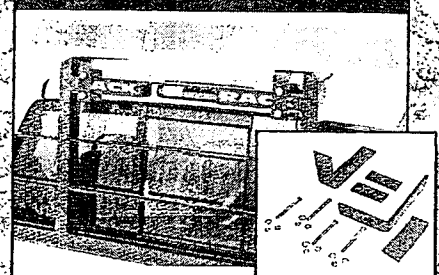

91006  
2 "L" Brackets included.  
Adapts to most light bars.  
No drilling required

## Sport Light

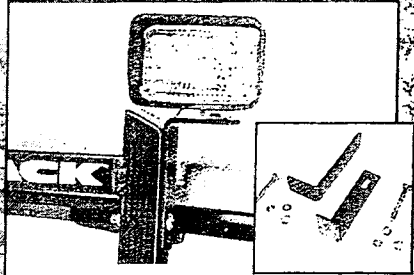

91005  
2 "L" Brackets included for use with  
sport light or other accessories.  
No drilling required

## Antenna

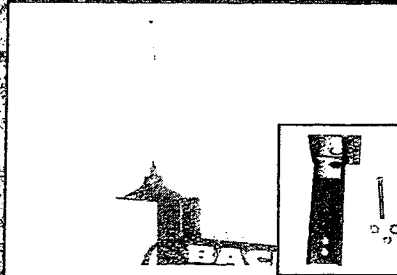

91008  
Mounts most antennas.  
3.5" x 3.5" mount surface with 7/8"  
pre-drilled hole.  
No drilling required

## Safety Rack - Multi-use



41000 Built to mount on Safety  
Rack. 10.5" x 10.5" mount surface.  
Self tap screws included. Two can  
be paired to mount a variety of  
accessories and lights.

LIGHTS SHOWN IN PICTURES ARE FOR DEMONSTRATION PURPOSES. BACKRACK™ SELLS THE BRACKETS ONLY.

BR00296

# BACKRACK™

One of the reasons people like BACKRACKS so much is because we make them "accessory friendly". Whether you want to mount toolboxes, cargo ladders, signal lights or antennas, BACKRACK has the accessory to get the job done. All brackets are coated with BACKRACKS durable powder-coat finish and all hardware is yellow zinc coated for superior corrosion resistance.

## TOOLBOX BRACKETS

Toolbox Brackets are used to mount "over-the-rail" style toolboxes. Of course, our customers have found a number of other creative uses for them as well. They are available in 21" (standard) and 31" lengths.

- 91010 - fits Backracks 10503/4/5/6/7/8/9, 10311, 10517
- 91011 - fits Backrack #10501 only
- 91012 - fits Backrack #10502
- 91013 - fits Backrack #10512
- 91010-C - fits Backrack #10310, 10312, 10313, 10502SC, 10512SC

Note: 31" Toolbox Brackets also available add "-31" to part#

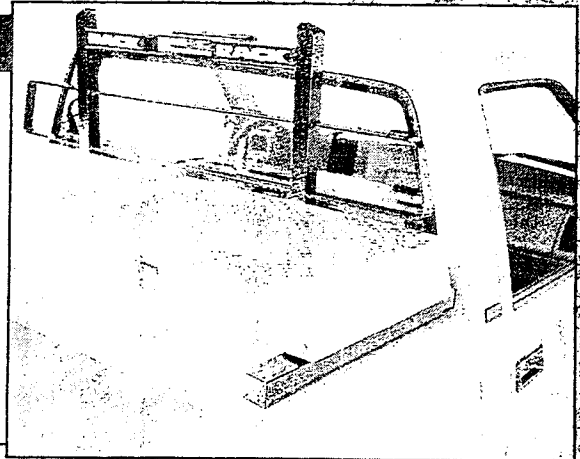

## REAR BARS

Rear bars are ideal for securing long cargo like ladders, lumber or pipe for example. They mount into the truck's stake pockets and therefore are custom designed for each vehicle. They are removable for storage when not in use. Unfortunately, they are not available on vehicles without stake pockets.

- See application chart on back cover to select the right one for your truck

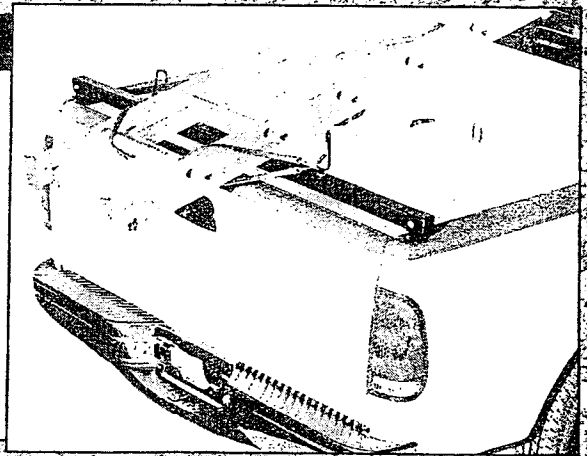

## LIGHT BRACKETS

BACKRACK is committed to its fleet and commercial customers who require signal lights, strobes, mini-light bars, arrow sticks, sport lights and more. We have brackets for every model making the BACKRACK and SAFETY rack the ultimate "LIGHT RACKS"! This year, we are proud to introduce the 91001F, 91003F which allows the user to rotate their strobe light upside down. Ideal for underground parking.

- See the detailed chart (opposite page) for each light bracket kit.

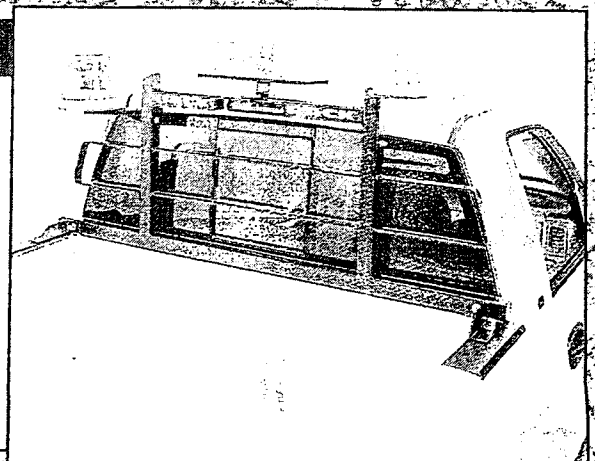

# BACKRACK™

YEAR	MAKE / MODEL	"the original" BACKRACK™ (Comes complete with mounting hardware)	SAFETY RACK FRAME ONLY (Choose hardware kit from next column on right)	INSTALLATION HARDWARE (Works with Backrack™ and Safety Rack)	REAR BAR
<b>CHEV/GMC</b>					
1999-TD	Silverado, Sierra	10509	10400	30109	11509
2007-08	Silverado, Sierra, GMT900 (New Body Style)	10519	10400	30119	11519
1988-98	CK Series, Classic Body Style	10503	10400	30103	11503
1968-88	Full Size Pick-up, All	10504	10400	30103	11504C
2005-TD	Colorado and Canyon	10316	10200	30116	
1982-2005	S10-S15, Sonoma	10312	10200	30110	
<b>DOGE</b>					
2002-TD	1500 (new body)	10517	10400	30117	11517
2003-TD	2500,3500 (new body)	10517	10400	30117	11517
1994-2001	1500, 2500, 3500	10507	10400	30107	11507
1969-1993	Full Size Pick-ups, All	10504	10400	30103	11504D
2005-TD	Dakota	10314	10200	30113	
1987-2004	Dakota	10313	10200	30113	
<b>FORD</b>					
2004-TD	F150 (Except Heritage)	10512	10400	30112	11512
1999-TD	F-Super Duty (Not UPS Shippable)	10501	10300	30201	11501
2004-TD	F150-Supercrew (No Stakepockets)	10512 SC	10400	30104	
1997-2003	F150, 250 Light Duty (and 2004 Heritage)	10502	10400	30102	11502
1975-1996	F-Series 8 ft bed	10506	10400	30106	11506
1975-1996	F-Series 6-1/2 ft bed	10505	10400	30105	11506
1999-2003	F150-Supercrew (Heritage) (No Stakepockets)	10502 SC	10400	30104	
1993-2005	Ranger	10311	10200	30111	11310R
<b>MAZDA</b>					
1989-1992	B-Series	10310	10200	30110	
1993-2005	B-Series	10311	10200	30111	11310 R
<b>NISSAN</b>					
1987-2004	Pick-up & Frontier	10312	10200	30110	
2004-TD	Titan	10511	10400	30511	
2005	Frontier	10314	10200	30113	
<b>TOYOTA</b>					
1984-1998	Pick-up	10310	10200	30110	
1993-1998	T-100	10508	10400	30108	
1997-2004	Tacoma (no rack available for 2005)	10313	10200	30113	
1999-2005	Tundra	10508	10400	30108	11508
2008	Tundra	10518	10400	30118	11518
2005-TD	Tacoma	N/A			

Notes: BACKRACK™, SAFETY RACK and Hardware Kits may be ordered with 21" Toolbox brackets at a lower price than if purchased separately. Add "TB" to the end of the part # when ordering.

TTAB – STK, LLC v. BACKRACK, INC.  
Cancellation No. 92049332 – Registration No. 3014986

## **EXHIBIT 24**



# BACKCRACK™

FUNCTION AND STYLE FOR TODAY'S TRUCKS

**NO DRILL  
INSTALLATION**

**NORTH AMERICAN  
MADE QUALITY**

**THE BRAND NAME  
YOU TRUST**

## SIDERAILS

- No drill installation
- Industrial Grade Quality & Strength
- Designed for working pickup trucks
- Compatible with or without Toolboxes
- Compatible with or without Backrack & Safetyrack
- Available for 6.5 & 8 ft beds

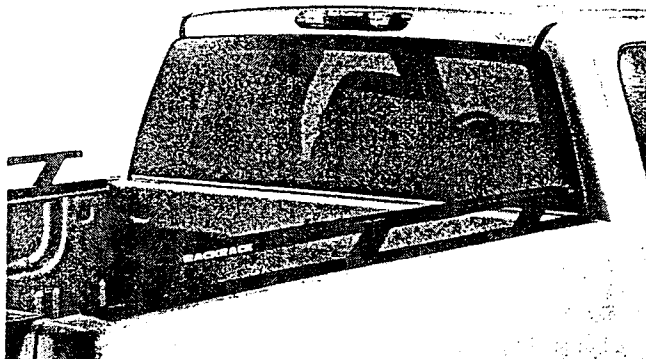

Stylish good looks combine with commercial grade strength. Secure heavy cargo with confidence. Function & Style for today's trucks

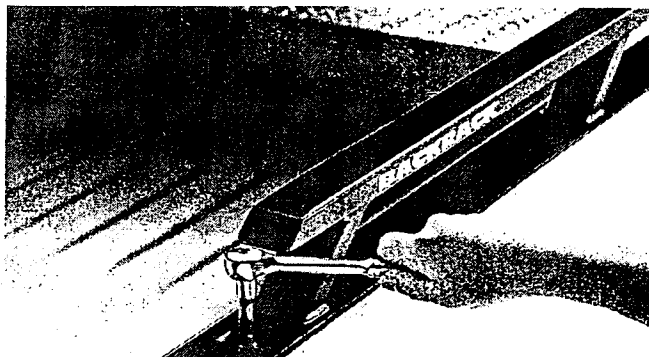
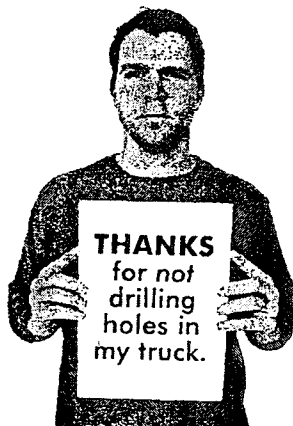

No drilling! Bolts rock solid into stake holes using simple ratchet. Backrack's custom Pocket Bolts make it quick, easy and strong.

YEAR/MAKE & MODEL	8 FT FULL RAIL	8 FT TOOLBOX	6.5 FT FULL RAIL	6.5 FT TOOLBOX
<b>CHEVY/CAD</b>				
2007-08 Silverado, Sierra (New Body)	SR80519	SR80519 TB	SR65519	SR65519 TB
1999-07 Silverado, Sierra, Classic	SR80509	SR80509 TB	SR65509	SR65509 TB
<b>FORD</b>				
2002-08 Dodge Ram, Fullsize	SR80517	SR80517 TB	SR65517	SR65517 TB
<b>FORD</b>				
1999-08 Superduty, F250, 350, 450	SR80501	SR80501 TB	SR65501	SR65501 TB
2004-08 F150, 6.5 ft & 8 ft Beds	SR80512	SR80512 TB	SR65512	SR65512 TB

- Full Tubular rail for trucks without Toolbox
- Rail stops short for trucks with Toolboxes
- See Application Chart for correct Part #'s

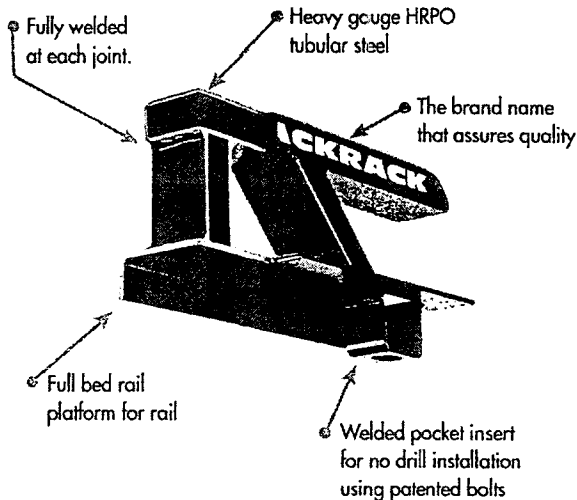
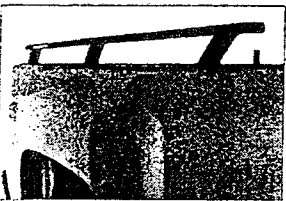
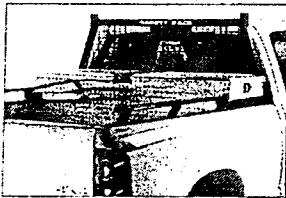
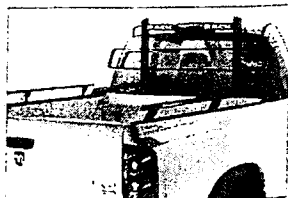

1775 W. 26th Road, Oakville, ON L6K 2E2 • 800-265-8137 • [backrack.com](http://backrack.com)

BR00350



TTAB – STK, LLC v. BACKRACK, INC.  
Cancellation No. 92049332 – Registration No. 3014986

## **EXHIBIT 25**

# BACKRACK™

FUNCTION AND STYLE FOR TODAY'S TRUCKS

#BX11008

NO-DRILL  
INSTALLATION

NORTH AMERICAN  
MADE QUALITY

THE BRAND NAME  
YOU TRUST

The **BACKRACK** DESIGN of the **BACKRACK** maintains you're trucks great looks while providing a functional rack that you can customize to fit your needs. **ADD ACCESSORIES** to mount lights or drop in a **REAR BAR** and your **BACKRACK** becomes a ladder rack that fits in your garage. Check our Product Guide on [backrack.com](http://backrack.com) for a full list of available accessories.

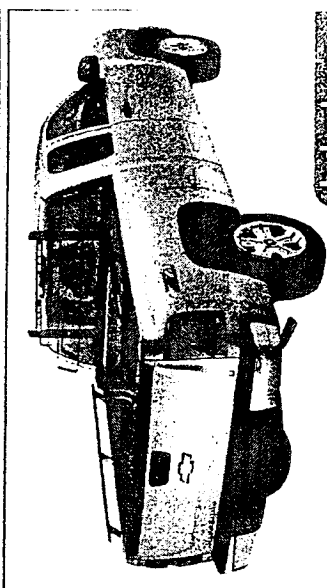

[backrack.com](http://backrack.com)

BR00358

TTAB – STK, LLC v. BACKRACK, INC.  
Cancellation No. 92049332 – Registration No. 3014986

## **EXHIBIT 26**

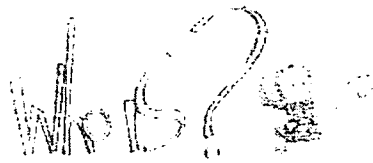

# Domains

Welcome Guest

[My Account](#) [Login](#) [Sign Up](#)

- [Domains](#)
- [Linux Hosting](#)
- [Windows Hosting](#)
- [Email](#)
- [Digital Certificates](#)
- [Site Builder](#)
- [Other Solutions](#)
- [Resellers](#)

- [Home](#)
- [My Account](#)
- [Register Domain](#)
- [Transfer Domain](#)
- [FAQs](#)
- [Contact Us](#)
- [Whois](#)
- [Knowledge Base](#)

## Whois Search Results

Domain Name : **backrack.ca**

Domain name: backrack.ca  
 Domain status: EXIST  
 Domain number: 122697  
 Approval date: 2000/11/10  
 Renewal date: 2009/12/01

Registrar:  
 Name: Tucows.com Co.  
 Number: 156

Registrant:  
 Name: Backrack Inc.  
 Number: 122697  
 Description: Backrack is a manufacturer of an accessory product for pick-up trucks that protects the rear cab window while providing a surface to mount warning lights, ladders and other loose cargo. Currently under [www.backrack4trucks.com](http://www.backrack4trucks.com).

Administrative contact:  
 Name: Adrian Jayne  
 Job Title:  
 Postal address: 475 Wyecroft Rd  
 Oakville ON L6K 2H2 Canada  
 Phone: 905-849-3633  
 Fax: 905-849-4116  
 Email: [info@backrack.ca](mailto:info@backrack.ca)

Technical contact:  
 Name: Network Admin  
 Job Title:  
 Postal address: EasyHosting.com  
 5415 Dundas Street West  
 Toronto ON M9B 1B5 Canada  
 Phone: (416) 233-7150  
 Fax: (416) 233-6970  
 Email: [postmaster@easyhosting.com](mailto:postmaster@easyhosting.com)

Name servers last changed: 2008/03/24  
 Name servers:  
 ns5.adverdea.com  
 ns6.adverdea.com

% WHOIS look-up made at 2008-10-27 17:50:11 (GMT)  
 %  
 % Use of CIRA's WHOIS service is governed by the Terms of Use in its Legal  
 % Notice, available at [http://www.cira.ca/en/legal\\_notice.html](http://www.cira.ca/en/legal_notice.html)  
 %

[Search the WHOIS Database](#)

### Quick Links

- [Register New](#)
- [Transfer](#)
- [Bulk Register](#)
- [Bulk Transfer](#)
- [Name Suggestion Tool](#)
- [Price List](#)
- [Domain / Mail Forwarding](#)
- [Managed DNS](#)

### Web/Email Hosting

- [Linux Hosting Plans](#)
- [Windows Hosting Plans](#)
- [Email-only Plans](#)
- [Demo](#)

### Digital Certificates

- [View Plans](#)
- [Features](#)
- [Compare Plans](#)

### Website Builder

- [View Plans](#)
- [Features](#)
- [Demo](#)

### Live Chat Services

- [View Plans](#)
- [Features](#)
- [Demo](#)

Domain Name \* EXAMPLE: somedomain.com

Security Key \* 98451

Please insert the security key from the image above into the box below. This key is used to verify that this page is not accessed by any automated processes.

Search

[Home](#) | [Account](#) | [Register Domain](#) | [Transfer Domain](#) | [Web Hosting](#) | [Email Hosting](#) | [Digital Certificates](#) | [Whois](#) | [Tools](#) | [Contact Us](#)

Copyright © Whois.com Pte Ltd. All Rights Reserved, Powered by Whois.com Pte Ltd

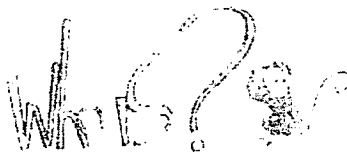

# Domains

Welcome Guest

[My Account](#) [Login](#) [Sign Up](#)

- [Domains](#)
  - [Linux Hosting](#)
  - [Windows Hosting](#)
  - [Email](#)
  - [Digital Certificates](#)
  - [Site Builder](#)
  - [Other Solutions](#)
  - [Resellers](#)
- 
- [Home](#)
  - [My Account](#)
  - [Register Domain](#)
  - [Transfer Domain](#)
  - [FAQs](#)
  - [Contact Us](#)
  - [Whois](#)
  - [Knowledge Base](#)

## Whois Search Results

Domain Name : [backrack.org](#)

NOTICE: Access to .ORG WHOIS information is provided to assist persons in determining the contents of a domain name registration record in the Public Interest Registry registry database. The data in this record is provided by Public Interest Registry for informational purposes only, and Public Interest Registry does not guarantee its accuracy. This service is intended only for query-based access. You agree that you will use this data only for lawful purposes and that, under no circumstances will you use this data to: (a) allow, enable, or otherwise support the transmission by e-mail, telephone, or facsimile of mass unsolicited, commercial advertising or solicitations to entities other than the data recipient's own existing customers; or (b) enable high volume, automated, electronic processes that send queries or data to the systems of Registry Operator or any ICANN-Accredited Registrar, except as reasonably necessary to register domain names or modify existing registrations. All rights reserved. Public Interest Registry reserves the right to modify these terms at any time. By submitting this query, you agree to abide by this policy.

Domain ID:D104963112-LROR  
 Domain Name:BACKRACK.ORG  
 Created On:04-Oct-2004 19:56:07 UTC  
 Last Updated On:04-Dec-2004 03:59:33 UTC  
 Expiration Date:04-Oct-2009 19:56:07 UTC  
 Sponsoring Registrar:Network Solutions LLC (R63-LROR)  
 Status:CLIENT TRANSFER PROHIBITED  
 Registrant ID:38518505-NSI  
 Registrant Name:Backrack Inc.  
 Registrant Organization:Backrack Inc.  
 Registrant Street1:475 Wyecroft Rd.  
 Registrant Street2:  
 Registrant Street3:  
 Registrant City:Oakville  
 Registrant State/Province:Ontario  
 Registrant Postal Code:L6K 2H2  
 Registrant Country:CA  
 Registrant Phone:+1.9058493633  
 Registrant Phone Ext.:  
 Registrant FAX:  
 Registrant FAX Ext.:  
 Registrant Email: [info@backrack.ca](mailto:info@backrack.ca)  
 Admin ID:38518505-NSI  
 Admin Name:Backrack Inc.  
 Admin Organization:Backrack Inc.  
 Admin Street1:475 Wyecroft Rd.  
 Admin Street2:  
 Admin Street3:  
 Admin City:Oakville  
 Admin State/Province:Ontario  
 Admin Postal Code:L6K 2H2  
 Admin Country:CA  
 Admin Phone:+1.9058493633  
 Admin Phone Ext.:  
 Admin FAX:  
 Admin FAX Ext.:  
 Admin Email: [info@backrack.ca](mailto:info@backrack.ca)  
 Tech ID:38518505-NSI

### Quick Links

- [Register New](#)
- [Transfer](#)
- [Bulk Register](#)
- [Bulk Transfer](#)
- [Name Suggestion Tool](#)
- [Price List](#)
- [Domain / Mail Forwarding](#)
- [Managed DNS](#)

### Web/Email Hosting

- [Linux Hosting Plans](#)
- [Windows Hosting Plans](#)
- [Email-only Plans](#)
- [Demo](#)

### Digital Certificates

- [View Plans](#)
- [Features](#)
- [Compare Plans](#)

### Website Builder

- [View Plans](#)
- [Features](#)
- [Demo](#)

### Live Chat Services

- [View Plans](#)
- [Features](#)
- [Demo](#)





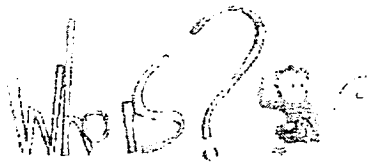

# Domains

Welcome Guest

[My Account](#) [Login](#) [Sign Up](#)

- [Domains](#)
  - [Linux Hosting](#)
  - [Windows Hosting](#)
  - [Email](#)
  - [Digital Certificates](#)
  - [Site Builder](#)
  - [Other Solutions](#)
  - [Resellers](#)
- [Home](#)
  - [My Account](#)
  - [Register Domain](#)
  - [Transfer Domain](#)
  - [FAQs](#)
  - [Contact Us](#)
  - [Whois](#)
  - [Knowledge Base](#)

## Whois Search Results

Domain Name : **backrack.info**

Access to INFO WHOIS information is provided to assist persons in determining the contents of a domain name registration record in the Afilias registry database. The data in this record is provided by Afilias Limited for informational purposes only, and Afilias does not guarantee its accuracy. This service is intended only for query-based access. You agree that you will use this data only for lawful purposes and that, under no circumstances will you use this data to: (a) allow, enable, or otherwise support the transmission by e-mail, telephone, or facsimile of mass unsolicited, commercial advertising or solicitations to entities other than the data recipient's own existing customers; or (b) enable high volume, automated, electronic processes that send queries or data to the systems of Registry Operator, a Registrar, or Afilias except as reasonably necessary to register domain names or modify existing registrations. All rights reserved. Afilias reserves the right to modify these terms at any time. By submitting this query, you agree to abide by this policy.

Domain ID:D7662248-LRMS  
 Domain Name:BACKRACK.INFO  
 Created On:04-Oct-2004 19:56:07 UTC  
 Last Updated On:18-Sep-2005 08:55:04 UTC  
 Expiration Date:04-Oct-2009 19:56:07 UTC  
 Sponsoring Registrar:Network Solutions (R122-LRMS)  
 Status:CLIENT TRANSFER PROHIBITED  
 Registrant ID:C6894169-LRMS  
 Registrant Name:Backrack Inc.  
 Registrant Organization:Backrack Inc.  
 Registrant Street1:475 Wycroft Rd.  
 Registrant Street2:  
 Registrant Street3:  
 Registrant City:Oakville  
 Registrant State/Province:Ontario  
 Registrant Postal Code:L6K 2H2  
 Registrant Country:CA  
 Registrant Phone:+1.9058493633  
 Registrant Phone Ext.:  
 Registrant FAX:  
 Registrant FAX Ext.:  
 Registrant Email: [info@backrack.ca](mailto:info@backrack.ca)  
 Admin ID:C6894169-LRMS  
 Admin Name:Backrack Inc.  
 Admin Organization:Backrack Inc.  
 Admin Street1:475 Wycroft Rd.  
 Admin Street2:  
 Admin Street3:  
 Admin City:Oakville  
 Admin State/Province:Ontario  
 Admin Postal Code:L6K 2H2  
 Admin Country:CA  
 Admin Phone:+1.9058493633

### Quick Links

- [Register New](#)
- [Transfer](#)
- [Bulk Register](#)
- [Bulk Transfer](#)
- [Name Suggestion Tool](#)
- [Price List](#)
- [Domain / Mail Forwarding](#)
- [Managed DNS](#)

### Web/Email Hosting

- [Linux Hosting Plans](#)
- [Windows Hosting Plans](#)
- [Email-only Plans](#)
- [Demo](#)

### Digital Certificates

- [View Plans](#)
- [Features](#)
- [Compare Plans](#)

### Website Builder

- [View Plans](#)
- [Features](#)
- [Demo](#)

### Live Chat Services

- [View Plans](#)
- [Features](#)
- [Demo](#)

Admin Phone Ext.:  
 Admin FAX:  
 Admin FAX Ext.:  
 Admin Email: [info@backrack.ca](mailto:info@backrack.ca)  
 Billing ID:C6831141-LRMS  
 Billing Name:Adrian Jayne  
 Billing Organization:  
 Billing Street1:475 Wycroft Rd.  
 Billing Street2:  
 Billing Street3:  
 Billing City:Oakville  
 Billing State/Province:Ontario  
 Billing Postal Code:L6K 2H2  
 Billing Country:CA  
 Billing Phone:+1.905849363  
 Billing Phone Ext.:  
 Billing FAX:  
 Billing FAX Ext.:  
 Billing Email: [info@backrack.ca](mailto:info@backrack.ca)  
 Tech ID:C6894169-LRMS  
 Tech Name:Backrack Inc.  
 Tech Organization:Backrack Inc.  
 Tech Street1:475 Wycroft Rd.  
 Tech Street2:  
 Tech Street3:  
 Tech City:Oakville  
 Tech State/Province:Ontario  
 Tech Postal Code:L6K 2H2  
 Tech Country:CA  
 Tech Phone:+1.9058493633  
 Tech Phone Ext.:  
 Tech FAX:  
 Tech FAX Ext.:  
 Tech Email: [info@backrack.ca](mailto:info@backrack.ca)  
 Name Server:ns55.worldnic.com  
 Name Server:ns56.worldnic.com  
 Name Server:  
 Name Server:  
 Name Server:  
 Name Server:  
 Name Server:  
 Name Server:  
 Name Server:  
 Name Server:  
 Name Server:  
 Name Server:  
 Name Server:  
 Name Server:

Search the WHOIS Database

Domain Name \*

EXAMPLE: somedomain.com

Security Key \*

34252

Please insert the security key from the image above into the box below. This key is used to verify that this page is not accessed by any automated processes.

Search

Copyright © Whois.com Pte Ltd. All Rights Reserved, Powered by Whois.com Pte Ltd



Welcome Guest

[My Account](#)

[Login](#)

[Sign Up](#)

- [Home](#)
- [Linux Hosting](#)
- [Windows Hosting](#)
- [Email](#)
- [Digital Certificates](#)
- [Site Builder](#)
- [Other Solutions](#)
- [Resellers](#)

- [Home](#)
- [My Account](#)
- [Register Domain](#)
- [Transfer Domain](#)
- [FAQs](#)
- [Contact Us](#)
- [Whois](#)
- [Knowledge Base](#)

### Whois Search Results

Domain Name: backrack.biz

#### Quick Links

- [Register New](#)
- [Transfer](#)
- [Bulk Register](#)
- [Bulk Transfer](#)
- [Name Suggestion Tool](#)
- [Price List](#)
- [Domain / Mail Forwarding](#)
- [Managed DNS](#)

#### Web/Email Hosting

- [Linux Hosting Plans](#)
- [Windows Hosting Plans](#)
- [Email-only Plans](#)
- [Demo](#)

#### Digital Certificates

- [View Plans](#)
- [Features](#)
- [Compare Plans](#)

#### Website Builder

- [View Plans](#)
- [Features](#)
- [Demo](#)

#### Live Chat Services

- [View Plans](#)
- [Features](#)
- [Demo](#)

Domain Name: BACKPACK.BIZ  
 Domain ID: D180181-BIZ  
 Sponsoring Registrar: NETWORK SOLUTIONS INC.  
 Sponsoring Registrar IANA ID: 2  
 Domain Status: clientTransferProhibited  
 Registrant ID: 38518505  
 Registrant Name: backpack inc.  
 Registrant Organization: Backpack Inc.  
 Registrant Address1: 475 Wycroft Rd  
 Registrant City: Oakville  
 Registrant State/Province: Ontario  
 Registrant Postal Code: L6K 2H2  
 Registrant Country: Canada  
 Registrant Country Code: CA  
 Registrant Phone Number: +1.9058493633  
 Registrant Email: wfg@backpack.ca  
 Administrative Contact ID: 38518505  
 Administrative Contact Name: Backpack Inc.  
 Administrative Contact Organization: Backpack Inc.  
 Administrative Contact Address1: 475 Wycroft Rd  
 Administrative Contact City: Oakville  
 Administrative Contact State/Province: Ontario  
 Administrative Contact Postal Code: L6K 2H2  
 Administrative Contact Country: Canada  
 Administrative Contact Country Code: CA  
 Administrative Contact Phone Number: +1.9058493633  
 Administrative Contact Email: wfg@backpack.ca  
 Billing Contact ID: 38489563  
 Billing Contact Name: Adrian Jayne  
 Billing Contact Address1: 475 Wycroft Rd  
 Billing Contact City: Oakville  
 Billing Contact State/Province: Ontario  
 Billing Contact Postal Code: L6K 2H2  
 Billing Contact Country: Canada  
 Billing Contact Country Code: CA  
 Billing Contact Phone Number: +1.9058493633  
 Billing Contact Email: wfg@backpack.ca  
 Technical Contact ID: 38518505  
 Technical Contact Name: Backpack Inc.  
 Technical Contact Organization: Backpack Inc.  
 Technical Contact Address1: 475 Wycroft Rd  
 Technical Contact City: Oakville  
 Technical Contact State/Province: Ontario  
 Technical Contact Postal Code: L6K 2H2  
 Technical Contact Country: Canada  
 Technical Contact Country Code: CA  
 Technical Contact Phone Number: +1.9058493633  
 Technical Contact Email: wfg@backpack.ca  
 Name Server: ns55.worldnic.com  
 Name Server: ns56.worldnic.com  
 Created by Registrar: NETWORK SOLUTIONS INC.  
 Last Updated by Registrar: NETWORK SOLUTIONS INC.  
 Domain Registration Date: Mon Oct 04 19:56:07 GMT 2004  
 Domain Expiration Date: Sat Oct 03 23:59:59 GMT 2009  
 Domain Last Updated Date: Fri Oct 08 14:54:45 GMT 2004

>>> Whois database was last updated on: Mon Oct 27 17:49:31 GMT 2006 <<<<

NeuLevel, Inc., the Registry Operator for .BIZ, has collected this information for the WHOIS database through an ICANN-Accredited Registrar. This information is provided to you for informational purposes only and is designed to assist persons in determining contents of a domain name registration record in the NeuLevel registry database. NeuLevel makes this information available to you "as is" and does not guarantee its accuracy. By submitting a WHOIS query, you agree that you will use this data only for lawful purposes and that, under no circumstances will you use this data: (1) to allow, enable, or otherwise support the transmission of mass unsolicited, commercial advertising or solicitations via direct mail, electronic mail, or by telephone; (2) in contravention of any applicable data and privacy protection acts; or (3) to enable high volume, automated, electronic processes that apply to the registry (or its systems). Compilation, repackaging, dissemination, or other use of the WHOIS database in its entirety, or of a substantial portion thereof, is not allowed without NeuLevel's prior written permission. NeuLevel reserves the right to modify or change these conditions at any time without prior or subsequent notification of any kind. By executing this query, in any manner whatsoever, you agree to abide by these terms

NOTE: FAILURE TO LOCATE A RECORD IN THE WHOIS DATABASE IS NOT INDICATIVE

Search the WHOIS Database

Domain Name \*      EXAMPLE: somedomain.com  
 Security Key \*     

35471

Please insert the security key from the image above into the box below. This key is used to verify that this page is not accessed by any automated processes.

Search

Copyright © Whois.com, Inc. All Rights Reserved. Powered by Whois.com, Inc. Ltd.

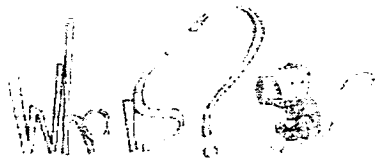

# Domains

Welcome Guest

[My Account](#) [Login](#) [Sign Up](#)

- Domains
  - Linux Hosting
  - Windows Hosting
  - Email
  - Digital Certificates
  - Site Builder
  - Other Solutions
  - Resellers
- 
- Home
  - My Account
  - Register Domain
  - Transfer Domain
  - FAQs
  - Contact Us
  - Whois
  - Knowledge Base

## Whois Search Results

Domain Name : **backrack.us**

Domain Name: BACKRACK.US  
 Domain ID: D10974373-US  
 Sponsoring Registrar: .US REGISTRAR L.L.C.  
 Registrar URL (registration services): whois.networksolutions.com  
 Domain Status: clientTransferProhibited  
 Registrant ID: 38518505V  
 Registrant Name: Backrack Inc.  
 Registrant Organization: Backrack Inc.  
 Registrant Address1: ATTN insert domain name here  
 Registrant Address2: care of Network Solutions  
 Registrant City: Herndon  
 Registrant State/Province: VA  
 Registrant Postal Code: 20172  
 Registrant Country: United States  
 Registrant Country Code: US  
 Registrant Phone Number: +1.570708878  
 Registrant Email: rg44p52c6xa@networksolutionsprivateregistration.com  
 Registrant Application Purpose: P1  
 Registrant Nexus Category: C31/CA  
 Administrative Contact ID: 38518505V  
 Administrative Contact Name: Backrack Inc.  
 Administrative Contact Organization: Backrack Inc.  
 Administrative Contact Address1: ATTN insert domain name here  
 Administrative Contact Address2: care of Network Solutions  
 Administrative Contact City: Herndon  
 Administrative Contact State/Province: VA  
 Administrative Contact Postal Code: 20172  
 Administrative Contact Country: United States  
 Administrative Contact Country Code: US  
 Administrative Contact Phone Number: +1.570708878  
 Administrative Contact Email: rg44p52c6xa@networksolutionsprivateregistration.com  
 Administrative Application Purpose: P1  
 Administrative Nexus Category: C31/CA  
 Billing Contact ID: 38489563V  
 Billing Contact Name: Adrian Jayne  
 Billing Contact Address1: ATTN insert domain name here  
 Billing Contact Address2: care of Network Solutions  
 Billing Contact City: Herndon  
 Billing Contact State/Province: VA  
 Billing Contact Postal Code: 20172  
 Billing Contact Country: United States  
 Billing Contact Country Code: US  
 Billing Contact Phone Number: +1.570708878  
 Billing Contact Email: wp5ph5u92cx@networksolutionsprivateregistration.com  
 Technical Contact ID: 38518505V  
 Technical Contact Name: Backrack Inc.  
 Technical Contact Organization: Backrack Inc.  
 Technical Contact Address1: ATTN insert domain name here  
 Technical Contact Address2: care of Network Solutions

### Quick Links

- Register New
- Transfer
- Bulk Register
- Bulk Transfer
- Name Suggestion Tool
- Price List
- Domain / Mail Forwarding
- Managed DNS

### Web/Email Hosting

- Linux Hosting Plans
- Windows Hosting Plans
- Email-only Plans
- Demo

### Digital Certificates

- View Plans
- Features
- Compare Plans

### Website Builder

- View Plans
- Features
- Demo

### Live Chat Services

- View Plans
- Features
- Demo



Technical Contact City: Herndon  
 Technical Contact State/Province: VA  
 Technical Contact Postal Code: 20172  
 Technical Contact Country: United States  
 Technical Contact Country Code: US  
 Technical Contact Phone Number: +1.570708878  
 Technical Contact Email: [ng44p53c6va@networksolutionsprivateregistration.com](mailto:ng44p53c6va@networksolutionsprivateregistration.com)  
 Technical Application Purpose: P1  
 Technical Nexus Category: C31/CA  
 Name Server: ns63.worldnic.com  
 Name Server: ns64.worldnic.com  
 Created by Registrar: .US REGISTRAR L.L.C.  
 Last Updated by Registrar: .US REGISTRAR L.L.C.  
 Domain Registration Date: Thu Sep 14 18:43:01 GMT 2006  
 Domain Expiration Date: Sun Sep 13 23:59:59 GMT 2009  
 Domain Last Updated Date: Thu Sep 14 18:43:05 GMT 2006

>>>> Whois database was last updated on: Mon Oct 27 17:50:27 GMT 2008 <<<<

NeuStar, Inc., the Registry Administrator for .US, has collected this information for the WHOIS database through a .US-Accredited Registrar. This information is provided to you for informational purposes only and is designed to assist persons in determining contents of a domain name registration record in the NeuStar registry database. NeuStar makes this information available to you "as is" and does not guarantee its accuracy. By submitting a WHOIS query, you agree that you will use this data only for lawful purposes and that, under no circumstances will you use this data: (1) to allow, enable, or otherwise support the transmission of mass unsolicited, commercial advertising or solicitations via direct mail, electronic mail, or by telephone; (2) in contravention of any applicable data and privacy protection laws; or (3) to enable high volume, automated, electronic processes that apply to the registry (or its systems). Compilation, repackaging, dissemination, or other use of the WHOIS database in its entirety, or of a substantial portion thereof, is not allowed without NeuStar's prior written permission. NeuStar reserves the right to modify or change these conditions at any time without prior or subsequent notification of any kind. By executing this query, in any manner whatsoever, you agree to abide by these terms.

NOTE: FAILURE TO LOCATE A RECORD IN THE WHOIS DATABASE IS NOT INDICATIVE OF THE AVAILABILITY OF A DOMAIN NAME.

All domain names are subject to certain additional domain name registration

Search the WHOIS Database

Domain Name \* EXAMPLE: somedomain.com

Security Key \* 14940

Please insert the security key from the image above into the box below. This key is used to verify that this page is not accessed by any automated processes.





### Whois Record for Backrack.com ( Back Rack )

#### Target Page Information

**Website Title:** BACKRACK.COM: Function and more for today's trucks  
**Title Relevancy:** 33%  
**AboutUs:** [View articles on Backrack.com](#)  
**SEO Score:** 40%  
**Terms:** 5 (Unique: 4, Linked: 0)  
**Images:** 14 (Alt tags missing: 14)  
**Links:** 4 (Internal: 4, Outbound: 0)

#### Registrar Data

**ICANN Registrar:** NETWORK SOLUTIONS LLC  
**Created:** 1998-12-14  
**Expires:** 2010-12-14  
**Updated:** 2005-06-26  
**Registrar Status:** clientTransferProhibited  
**Name Server:** NS69.WORLDNIC.COM (has 1,807,841 domains)  
**Name Server:** NS70.WORLDNIC.COM  
**Whois Server:** whois.networksolutions.com

#### Server Data

**IP Address:** 205.178.189.131 [View IP IP](#) [View IP](#)  
**IP Location:** - Virginia - Herndon - Network Solutions LLC  
**Response Code:** 200  
**Domain Status:** Registered And Active Website

#### DomainTools Exclusive

**Registrant Search:** "Backrack Inc." owns about 10 other domains  
**Registrar History:** 1 registrar  
**NS History:** 1 change on 2 unique name servers over 4 years.  
**IP History:** 4 changes on 3 unique name servers over 4 years.  
**Whois History:** 9 records have been archived since 2000-04-09.  
**Reverse IP:** 365,308 other sites hosted on this server.  
**Monitor Domain:** [Set Free Alerts on backrack.com](#)  
**Free Tool:** [Download DomainTools for Windows](#)

**SUBMIT YOUR DOMAINS for LIVE AUCTION**

#### Whois Record

```

Domain Name: BACKRACK.COM
Registrar: NETWORK SOLUTIONS, LLC
Registration Date: 1998-12-14
Expiration Date: 2010-12-14
Updated Date: 2005-06-26
Status: clientTransferProhibited
Name Server: NS69.WORLDNIC.COM
Name Server: NS70.WORLDNIC.COM
Whois Server: whois.networksolutions.com

```

Thumbnail: 2005-06-26

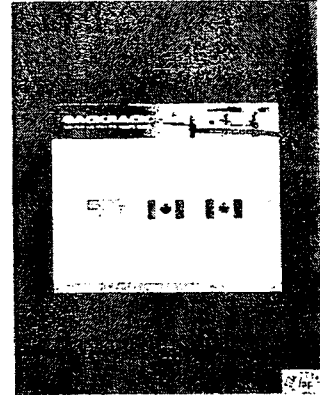

Historical Thumbnails: 6 records



[View Thumbnail History](#)

#### SEO Text Browser

##### SEO Text Browser

button\_backrackbutton\_accessoriesbutton\_who  
 U.S.  
 CANADA  
 (English)  
 CANADA  
 (Français)

<http://www.backrack.com>

[Enable SEO Text Browser](#) | [Print](#)

[Hide Key](#)

#### Other TLDs

[.com](#) [.net](#) [.org](#) [.biz](#) [.info](#) [.us](#)

#### Symbol Key

- Available
- Available (Previously registered)
- Registered (Active website)
- Registered (Parked or redirected)
- Registered (No website)
- On-Hold (Generic)
- On-Hold (Redemption Period)
- On-Hold (Pending Deletion)
- Monitor



Create

## Domains for Sale

Domain	Price
Pergram-Rack.com	\$200.00
RackOnline.com	\$500.00
AirRack.com	\$500.00
RackOn.com	\$500.00
RackDiscount.com	\$500.00
RackE.com	\$500.00
Cap.Rack.com	\$500.00
CheapPack.com	\$500.00
AirRack.com	\$895.00
ERack.com	\$999.00
RackWeb.com	\$1,000.00

## Domains At Auction

Domain	Auction Date
EastPeoriaBookPack.com	10-29-2008
FastPackDeliveries.com	10-30-2008
OldRack.com	10-30-2008
FcRack.net	10-30-2008
PureSprack.com	10-30-2008
SoftRackTech.com	10-31-2008
Eco-Snell.com	10-31-2008
TSHRack.com	10-31-2008
DadsRack.com	11-11-2008
PackemStackEm.com	11-16-2008
ApRack.com	11-23-2008

## Compare Similar Domains

Domain	Created
Back Rack	1993-12-14
Back Rack 4 Trucks	2005-05-04
Back Radar	2000-09-28
Back Krack	2003-12-05
Back Rack Moving	2004-02-08
Back Racks	2005-02-04
Back Pad Inc	2005-03-14
Back Ra C	2005-12-05
Back Rack Fort Rucks	2005-12-06
Back Pa Cars	2006-04-18
Back Pacing	2006-04-18
Back Rack Shoes	2006-04-22
Back Rack	2006-05-10
Back Rabbit Site	2006-05-31
Back Rabbit Web	2006-05-31



### Whois Record for Backrack4trucks.com ( Back Rack 4 Trucks )

#### Whois Page Information

**Website Title:** BACKRACK 4 Trucks and give for today's trucks  
**Title Relevancy:** 64%  
**AboutUs:** About Us article on Backrack4trucks.com  
**SEO Score:** 40%  
**Terms:** 5 (Unique: 4, Linked: 0)  
**Images:** 14 (Alt tags missing: 14)  
**Links:** 4 (Internal: 4, Outbound: 0)  
**Related Sites:** aerotecinc.com, hawkcompany.com, alibabainfg.com, aliamnumtrucktrucks.com, emitechsprings.com, autofab.com, bakline.com, buytruckstuff.com

#### Indexed Data

**Alexa Trend/Rank:** #2,619,211 458,041 ranks over the last three months.

#### Registry Data

**ICANN Registrar:** NETWORK SOLUTIONS, LLC  
**Created:** 2000-05-09  
**Expires:** 2011-05-09  
**Updated:** 2006-10-12  
**Registrar Status:** ClientTransferProhibited  
**Name Server:** NS1.BELLHOSTING.COM (net 1,375 domains)  
**Name Server:** NS2.BELLHOSTING.COM  
**Whois Server:** whois.networksolutions.com

#### Server Data

**Server Type:** Microsoft-IIS/6.0  
**IP Address:** 69.156.240.30 W F P  
**IP Location:** - Ontario - Toronto - Bell Canada Web Site Hosting  
**Response Code:** 200  
**Domain Status:** Registered And Active Website

#### DomainTools Exclusive

**Registrant Search:** "Backrack Inc." owns about 10 other domains  
**Registrar History:** 2 registrars  
**NS History:** 1 change on 2 unique name servers over 5 years.  
**IP History:** 2 changes on 2 unique name servers over 4 years  
**Whois History:** 7 records have been archived since 2003-05-24.  
**Reverse IP:** 945 other sites hosted on this server.  
**Monitor Domain:** Set Free Alerts on backrack4trucks.com  
**Free Tool:** Download DomainTools for Windows

**SUBMIT YOUR DOMAINS for LIVE AUCTION**

#### Whois Record

**Registrant:**  
 Backrack Inc.  
 477 Woodbine Ave.  
 Markham, ON L3R 9V7  
 CA  
 Phone: +1-905-477-1100  
 Fax: +1-905-477-1100  
 E-mail: [backrack@backrack4trucks.com](mailto:backrack@backrack4trucks.com)  
**Administrative Contact: DomainTools, Inc.**  
 477 Woodbine Ave.  
 Markham, ON L3R 9V7  
 CA  
 Phone: +1-905-477-1100

#### Thumbnail

2006-07-13

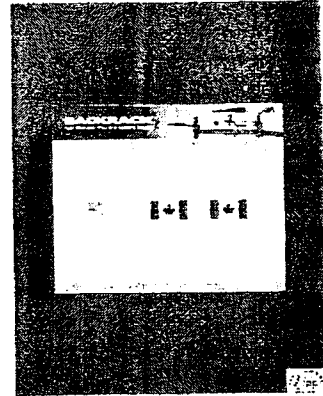

#### Historical Thumbnails

5 records

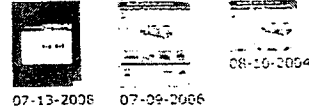

07-13-2006 07-09-2006 08-10-2004  
[View Thumbnail History](#)  
[Queue this Domain for Update](#)

#### SEO Text Browser

##### SEO Text Browser

button\_backrackbutton\_accessiblebutton\_whe  
 U.S.  
 CANADA  
 (English)  
 CANADA  
 (Francais)

<http://www.backrack4trucks.com>

Disable SEO Text Browser

#### Other TLDs

.com .net .org .biz .info .us

#### Symbol Key

- Available
- Available (Previous registered)
- Registered (Active website)
- Registered (Parked or redirected)
- Registered (No website)
- On-Hold (Generic)
- On-Hold (Redemption Period)
- On-Hold (Pending Delete)





Domains for Sale

Domain	Price
FastTrucks.com	\$25.00
SpeedTrucks.com	\$150.00
HighTrucks.com	\$249.00
ReadyTrucks.com	\$666.00
TrucksWorld.com	\$666.00
FineTrucks.com	\$999.00
WoodTrucks.com	\$1,299.00
GoodTrucks.com	\$1,788.00
LocalTrucks.com	\$1,788.00
QuoteTrucks.com	\$1,788.00
TalkingTrucks.com	\$1,888.00

Domains At Auction

Domain	Auction Date
WinNewAutos.com	10-29-2008
TopAutosOnline.com	10-29-2008
YesterdaysTrucks.com	10-29-2008
AutosGarage.com	10-29-2008
BassFishingRigs.com	10-29-2008
AllMyAutos.net	10-29-2008
IsSvAutos.com	10-29-2008
Autos4-2.com	10-29-2008
Repo-Autos.net	10-29-2008
SentryAutos.com	10-29-2008
SuperTrucksRacing.com	10-29-2008
VespaAutos.com	10-30-2008
NeoAutos.net	10-30-2008

Compare Similar Domains

Domain	Created
Back Rack	1996-12-14
Back Rack 4 Trucks	2000-05-09
Back Radar	2000-09-28
Back Kragh	2003-12-09
Back Rack Hosting	2004-02-08
Back Racks	2005-02-04
Back Rad Inc	2005-03-14
Back Re C	2005-12-06
Back Rack Fort Rucks	2005-12-06
Back Pads	2005-12-06
Back Ra Cars	2006-04-18
Back Pacing	2006-04-18
Back Rack Shoes	2006-04-22
Back Race	2006-05-22
Back RaBot Web	2006-05-23

BR00476

TTAB – STK, LLC v. BACKRACK, INC.  
Cancellation No. 92049332 – Registration No. 3014986

## **EXHIBIT 27**





auto, sport-utility, van and truck accessories & equipment



Home Products About Us Armor Paint Dealer Locator FAQ Site Map Become a Reseller Contact Us Search New Products

SEARCH BY: Categories - Select Category -

Product

Brand - Select Brand-



Contractor-Industrial

[HOME](#) > [CONTRACTOR-INDUSTRIAL](#)

Here is a list of our **Contractor-Industrial** categories. Click on any of the links below to view a list of products by brand. Browse at your leisure among our extensive selection: you're sure to find something you need among these Contractor-Industrial products!

- |                                     |                                |                              |
|-------------------------------------|--------------------------------|------------------------------|
| <a href="#">Bed Caps</a>            | <a href="#">Bed Mats</a>       | <a href="#">Bed Rails</a>    |
| <a href="#">Bedliners</a>           | <a href="#">Cab Guards</a>     | <a href="#">Fuel Pumps</a>   |
| <a href="#">Fuel Transfer Tanks</a> | <a href="#">Job Site Boxes</a> | <a href="#">Ladder Racks</a> |
| <a href="#">Ramps</a>               | <a href="#">Tie-Downs</a>      | <a href="#">Tool Boxes</a>   |
| <a href="#">Wheel Simulators</a>    | <a href="#">Wheels</a>         |                              |

### Truck wheels, tool boxes, ladder racks, bedliners: truck accessories for contractors

Professional contractors and industrial truck user have a particular need for high-quality, reliable truck accessories. As a contractor, whether you're looking for **tool boxes, bedliners**, wheel simulators, or ladder racks, you know you can't afford to be let down by an unreliable truck accessory. Here at Armor Deck we've assembled a catalog of high-quality, professional-grade truck accessories from proven and reputable manufacturers. Our customers have high standards for their accessories, from tool boxes and bedliners to ladder racks and more. We're glad to reflect those high standards in our range of contractor/industrial truck accessories!

#### TRUCK ACCESSORY CATALOG FEATURING FUEL TRANSFER TANKS, JOB SITE TOOL BOXES, BED RAILS AND MORE

As a contractor, you have unique needs for aftermarket truck accessories and equipment that the average recreational vehicle owner may not need such as fuel transfer tanks, job site tool boxes, or heavy duty cab guards. So get it right the first time and buy your truck accessories through Armor Deck.

[Home](#) | [Products](#) | [About Us](#) | [Armor Paint](#) | [Dealer Locator](#) | [FAQ](#) | [Site Map](#) | [Become a Reseller](#) | [Contact Us](#) | [Search](#)

Special Features: [Armor Deck News](#) | [Featured Brand](#) | [Automotive Tips](#) | [Career Opportunities](#) | [Downloads](#)

©2003 Armor Deck All rights reserved. Use of this web site constitutes acceptance of the Armor Deck [Website User Agreement](#). Date: Wednesday, May 14, 2008

Armor Deck, 280 North Midland Avenue, Saddle Brook, New Jersey 07663 | 1-800-222-3325 | [Terms and Policies](#) | [Related Resources](#)

BR00230



auto, sport-utility, van and truck accessories & equipment



Home Products About Us Armor Paint Dealer Locator FAQ Site Map Become a Reseller Contact Us Search New Products

SEARCH BY: Categories - Select Category -

Product

Brand - Select Brand -



Contractor-Industrial

HOME > CONTRACTOR-INDUSTRIAL > CAB GUARDS

### Cab Guards



#### 1. BACKRACK™

BACKRACK is fast becoming standard equipment on fleet vehicles across North America.

[Backrack™ Truck Racks and Cab Guards](#)

[Light Bar Brackets](#)

[Safety Rack™](#)

[Tool Box Brackets](#)



#### 2. STK®

STK prides itself on being a customer-driven company that is quick to react to the needs of its business partners. This is the distinguishing characteristic that sets STK apart from the competition.

[Light Bar Brackets](#)

[Pro Guard](#)

[Pro Rack](#)

[Tail Bar](#)

[Tool Box Brackets](#)

Home Products About Us Armor Paint Dealer Locator FAQ Site Map Become a Reseller Contact Us Search

Special Features: [Armor Deck News](#) | [Featured Brand](#) | [Automotive Tips](#) | [Career Opportunities](#) | [Downloads](#)

©2008 Armor Deck. All rights reserved. Use of this web site constitutes acceptance of the Armor Deck [Website User Agreement](#). Date: Wednesday, May 14, 2008

Armor Deck, 280 North Midland Avenue, Saddle Brook, New Jersey 07663 | 1-800-222-3325 | [Terms and Policies](#) | [Related Resources](#)

BR00231

TTAB – STK, LLC v. BACKRACK, INC.  
Cancellation No. 92049332 – Registration No. 3014986

## **EXHIBIT 28**



[Advanced Search](#) [Home](#)

Workvan

Search Results

Found 1 product(s) for Truck Equipment: Cab Guards (1-1 of 1)

Truck Equipment | Cab Guards

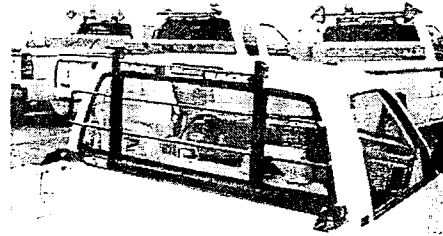
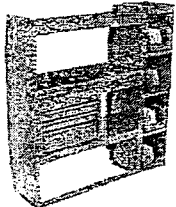
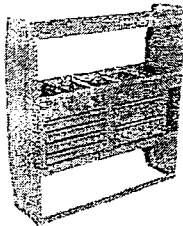
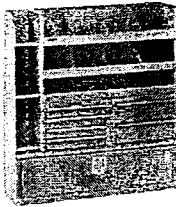

**14-1-10509**  
 The BACKRACK™ design provides excellent cab protection while providing a sturdy structure to secure cargo, carry ladders and mount a variety of warning lights. BACKRACK™ can be installed within minutes without drilling on most trucks. Fits Chevrolet and GMC full-size pickup trucks models 99 to current.

PRICE: \$312.00 [Add to Cart ->](#)

- [Categories](#)
- [Electrical Accessories](#)
- [Truck Equipment](#)
- [Accessories](#)
- [Cab Guards](#)
- [Truck Racks](#)
- [Van Equipment](#)
- [Accessories](#)
- [Adjustable Shelving](#)
- [Data & Storage Files](#)
- [Ladder Racks](#)
- [Modular Components](#)
- [Partitions](#)

[View Cart](#)  
 Empty

[Checkout](#)

[About Us](#)  
[Service](#)  
[Policies](#)

[Search](#)



[Advanced Search](#) | [View Cart](#) | [Checkout](#) | [about us](#) | [Service](#) | [Policies](#) | [Home](#)

*Are You Ready? Just 225 days 'til Christmas!*



Commerce enabled by ProStores

Copyright © 2008 US Workvan. All Rights Reserved.

BR00239

TTAB – STK, LLC v. BACKRACK, INC.  
Cancellation No. 92049332 – Registration No. 3014986

## **EXHIBIT 29**



Need Husky Liners? Click here!  
 Visit our Tonneau Cover Info site!

**HOME CONTACTUS PARTS SERVICE HISTORY**

**GO SHOPPING HELP**

**STORE FRONT YOUR ACCOUNT BASKET CONTENTS**

**CHECKOUT**

Privacy Policy Return Policy Shopping FAQ

Power Search  
 Widen Search  
 Search our store:

Search

Sign In

- Light Truck and Car Accessories
- BackRack Cab Guards
- BackRack Accessories
- Bug Shields
- Floor Liners - Husky
- Lights - Safety/Warning
- Mud Guards
- Nerf Bars
- Tonneau Covers
- Towing Mirrors



100% Secure Online Transactions

## BackRack Cab Guards

BackRack cab guards are perfect for the job site. They offer protection to the rear window and still give lots of visibility. These cab guards feature heavy duty construction with each one weighing approximately 70 pounds. Most kits mount solidly into the truck's stake pocket holes with a no-drill installation. Trucks without stake pockets may require drilling.



The heavy duty construction also creates a perfect location for securing cargo and mounting lights and toolboxes. Be sure to choose the BackRack cab guard kit with toolbox brackets if you plan to mount a toolbox. This will allow for installation of a box up to 21 inches wide.

The prices below do not include shipping. You will be shown the shipping charge during checkout before you are asked for your credit card.

### BackRack Pickup Application Guide

General Motors		\$269.00	\$269.00
Year	Model	Standard Brackets	Toolbox Brackets
2004-2007	GM Colorado/Canyon	10316	10316TB
1982-2004	GM S-Series	10312	10312TB
1999-2007	GM Silverado/Sierra Classic	10509	10509TB
1988-1999	GM C/K Pickup (Pre-1999 body style)	10503	10503TB
1968-1987	GM Full-Size Pickup	10504	10504TB
Ford		\$269.00	\$269.00
Year	Model	Standard Brackets	Toolbox Brackets
1993-2007	Ford Ranger	10311	10311TB
1999-2007	Ford Super Duty	10501	10501TB
2004-2007	Ford F150 (new body style)	10512	10512TB
2004-2007	Ford F150 Super Crew (new body style)	10512SC	10512SCTB
1997-2003	Ford F150	10502	10502TB
1999-2003	Ford F150 Super Crew	10502SC	10502SCTB
		\$269.00	\$269.00

BR00240

**Dodge**

Year	Model	Standard Brackets	Toolbox Brackets
2005-2007	Dodge Dakota	10314	10314TB
1987-2004	Dodge Dakota	10313	10313TB
2002-2007	Dodge Ram 1500		
2003-2007	Dodge Ram 2500/3500 (new body style)	10517	10517TB
1994-2001	Dodge Ram 1500		
1994-2002	Dodge Ram 2500/3500 (old body style)	10507	10507TB
1969-1993	Dodge Full-Size Pickup	10504	10504TB

**Nissan**

Year	Model	Standard Brackets	Toolbox Brackets
1987-2004	Nissan Frontier	10312	10312TB
2004-2007	Nissan Titan	10511	10511TB

**Toyota**

Year	Model	Standard Brackets	Toolbox Brackets
1999-2006	Toyota Tundra	10508	10508TB
1997-2004	Toyota Tacoma	10313	10313TB

**Site Map - A list of all links on this website**  
**Links - Links to vendor and other related websites**

Copyright © 2007 Mutual Wheel Company All rights reserved.  
 All prices and specifications are subject to change without notice.  
 Mutual Wheel Company is not responsible for typographical errors. All typographical errors are subject to correction

BR00241

TTAB – STK, LLC v. BACKRACK, INC.  
Cancellation No. 92049332 – Registration No. 3014986

## **EXHIBIT 30**





Privacy | Customer Service | View Cart  
Toll Free (866) 584-1084 Mon-Fri 8am-5pm CST



**View Our  
Commercial  
Vehicle Products**

## BACKRACK Cab Guards

**FREE SHIPPING ON BACKRACK PRODUCTS!**  
Free Freight Rules

### Shop by Brand:

Select A Brand

[Truck Accessories Home Page](#)

### Shop by Category:

- [BED RAIL CAPS](#)
- [BILLET GRILLES](#)
- [CAR CARE](#)
- [DEFLECTORS](#)
- [FENDER FLARES](#)
- [FLOOR LINERS - HUSKY LINERS](#)
- [GAS DOORS](#)
- [GRILLE GUARDS](#)
- [HITCHES - TOWING ACC.](#)
- [LIGHTS - PIAA](#)
- [MUD GUARDS](#)
- [NERF BARS](#)
- [PAINT PROTECTION - HUSKY SHIELD](#)
- [PERFORMANCE](#)
- [RACKS - BACKRACK](#)
- [SUSPENSIONS](#)
- [TAILGATES - 5TH WHEEL](#)
- [TAIL LIGHT COVERS](#)
- [TIRE CARRIER - H2](#)
- [TONNEAU COVERS](#)
- [TRIM - CHROME & POLISHED](#)
- [WINDOW GRAPHICS](#)
- [WIPER BLADES](#)

[SITE MAP](#)



**Have Questions?**  
Email our sales staff at  
[Sales@AnythingTruck.com](mailto:Sales@AnythingTruck.com)

BackRack cab guards are fast becoming standard equipment on fleet vehicles across North America. The design of the BackRack provides versatility to the fleets and individual contractors who use the cab guard for its function and style.

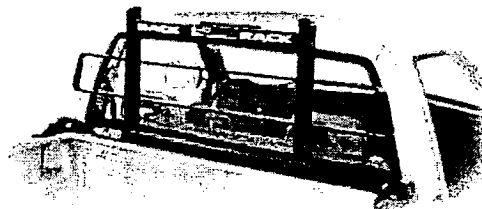

Built with heavy gauge "pickled and oiled" steel tubing that gives a clean, scale-free finish for maximum rust resistance, the BackRack cab guard provides strength and utility while maintaining the style of your pickup truck.

**BR00237**

**\*Please make a selection in each of the boxes and click the Go button to see pricing.\***

Vehicle Make  Vehicle Year

### 10 Reasons to Choose BACKRACK Cab Guards

1. Stylish appearance is functional and attractive
2. Rugged steel construction - built to perform on the toughest job sites
3. Powdercoated, not painted, for maximum rust resistance
4. Third brake light on the cab is completely visible
5. Protects the cab and rear window from damage
6. Secures cargo to prevent shifting
7. Provides mounting locations for lights and other accessories
8. Wide variety of accessory brackets available
9. Bed liner and toolbox friendly
10. Easy to install - no drilling for most trucks

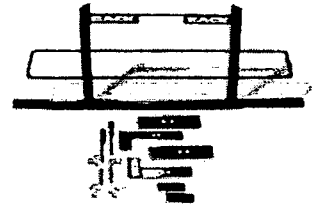

**Here's one more...The BackRack comes with a limited lifetime warranty!**

**Orders shipped to Illinois are subject to sales tax.**

Copyright © 2008 AnythingTruck.com All rights reserved. Sales@AnythingTruck.com

BR00238

TTAB – STK, LLC v. BACKRACK, INC.  
Cancellation No. 92049332 – Registration No. 3014986

## **EXHIBIT 31**

M-Th 9am - 7pm EST Sun - 6pm  
 Wed - 9pm Sat - 10am - 2pm EST

**4 WHEEL ONLINE**  
 .com  
 Always the Best Place to Shop

No Hidden Handling Charges!! - 1176

Phone: 888-476-5745

Truck/SUV | Jeep | Hummer | Muscle

Trucks & SUVs | Trucks & SUVs | Trucks & SUVs | Trucks & SUVs

- Truck and SUV
- Hummer
- Jeep
- Muscle Car
- Exterior Accessories
  - Grills and Grill Inserts
  - Headache Racks
  - Paint Shields & Bug Deflectors
  - Truck Bed Racks
  - Tyre Management & Post Racks
  - Truck Bed & Tonneau Accessories
- Tonneau Covers
- Nerf Bars
- Fender Flares
- Interior Accessories
- Air Induction
- Audio Video
- Bestop Tops
- Body Lifts
- Brake Systems
- Bumpers
- Diesel Performance
- Drivetrain
- Exhaust Kits
- Leveling Kits
- Lighting
- Locking Hubs
- Lowering Kits
- Performance Upgrades
- Shock Absorbers
- Suspension Lift Kits
- Tires
- Wheels
- Winches
- Shop Equipment
- Clearance Items
- Check Out!
- Vehicles for Sale
- Info
- Privacy Policy
- My Account
- Customer Rides!
- RETURNS
- WARRANTY INFO
- Price Quotes / Match

(SUV) - (Exterior Truck Accessories) - (Headache Racks) - (BackRack Headache Racks)

Add this page to your favorites Send this page to a friend

**BackRack Headache Racks**

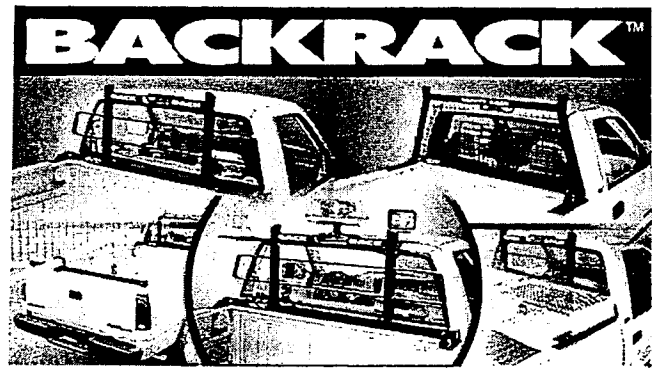

- EASY TO INSTALL • NO DRILLING ON MOST MODELS • ACCESSORY FRIENDLY •
- LIMITED LIFETIME WARRANTY • DURABLE POWDERCOAT FINISH •

The BACKRACK™ design provides excellent cab protection while providing a sturdy structure to secure cargo, carry ladders and mount a variety of warning lights. The BACKRACK™ can be installed within minutes without drilling on most trucks. More than 20 available accessory brackets provide easy, mounting of toolboxes, strobes, arrow sticks, light bars, antennas, spot lights and more. Here are some of the many reasons to add a BACKRACK™ to your truck.



**BackRack Original Headache Rack**    **BackRack Safety Headache Rack**    **BackRack Truck Rack Accessories**

Please choose from one of the popular BackRack Headache styles above. The Original offers a simple tubular design. The Safety Headache Rack offers a great degree of cab protection from objects in the bed of your truck. After choosing the Headache Rack for you, do not forget to review all of the BackRack Headache Rack accessories; Light Brackets, Rear Backs, and Tool Box Brackets.

Truck Headache Racks - Quick Find Guide  
[BackRack Headache Racks](#) | [BackRack Original Headache Racks](#) | [BackRack Safety Headache Racks](#) | [Tough Country Headache Racks](#) | [Tough Country Louvered Headache Racks](#) | [Tough Country Louvered Heavy Duty Headache Racks](#) | [Tough Country Headache Rack Accessories](#)

Image(s) may not reflect the product(s) being sold.

**Why 4 Wheel Online?**  
 Let us show you!

**New Customer Service Hours:**  
 Mon - Thurs: 9:00am - 7:00pm EST  
 Fri: 9:00am - 6:00pm EST

**BUY 4 SKYJACKER HYDRO-NITRO SHOCKS GET \$35 CASH BACK**

**CHECK OUT**

**SKYJACKER**

**FEATURES**

- 150 PSI PRESSURIZED NITROGEN GAS (NITRO ONLY)
- ORWICE DISK
- VELOCITY SENSITIVE VALVING
- LEAK PROOF SEAL
- BONDED IRON PISTON
- CHROME PISTON ROD
- RED BOOT INCLUDED
- RED POLYURETHANE BUSHINGS
- LIMITED LIFETIME WARRANTY

**GET \$35.00 CASH BACK!**

Rebate Runs March 1st - May 31st 2006

**tread lightly!**  
 LEAVING A GOOD IMPRESSION

Sat: 10:00am - 7:00pm EST

If you have any questions just give us a call:  
1-813-769-2451

**\*\*UNLIKE OUR COMPETITION 4 WHEEL ONLINE HAS\*\***  
**\*\*NO HANDLING FEES OR HIDDEN CHARGES\*\***

[About Us](#) • [Shipping](#) • [Policy](#) • [Contact Us](#) • [Home](#)

Copyright © 1999-2007 4 Wheel Online

4 Wheel Online Quick Find Guide

Truck SUV Accessories Parts

Truck Accessory Exterior

- Tonnau Covers
  - Access Tonnau, Access Tonnau Covers
  - EAT Tonnau, BAK Tonnau Covers
  - TruXedo Tonnau, TruXedo Tonnau Covers
  - Tella Tonnau, Tella Tonnau Covers
  - Tonnau Master, Tonnau Master
- Tonnau Covers
  - Tonnau Tonnau, Tonnau Tonnau Covers
  - Dwayne Tonnau, Dwayne Tonnau Covers
  - Eric Edwards Tonnau, Eric Edwards Tonnau Covers
  - Undercover Tonnau, Undercover Tonnau Covers
  - Living Tonnau, Living Tonnau Covers
  - Lund Tonnau, Lund Tonnau Covers
  - Adventure Tonnau, Adventure Tonnau Covers
  - Bullitt Tonnau, Bullitt Tonnau Covers
  - DiamondBack Tonnau, DiamondBack Tonnau Covers
  - Roll N Lock Tonnau, Roll N Lock Tonnau Covers
  - Staged Liner Tonnau, Staged Liner Tonnau Covers
  - Top Cover Tonnau, Top Cover Tonnau Covers
  - Fold-A-Cover Tonnau, Fold-A-Cover Tonnau Covers
  - Mile Maker Tonnau, Mile Maker Tonnau Covers
- Truck Bed Covers
  - ATV Plans
  - ATV Steps Pads
  - Truck Fender Flares
  - Truck Flares
  - Truck Racks
  - Headache Rack
  - Truck Lights
  - Head Shields, Bug Deflectors
  - Bitter Grille, Grille Inserts
  - Mirror Box, Side Step & Running Boards
  - Power Step, Step P PowerStep, AMP PowerStep
  - Truck Fins, Truck Fender Flares
  - Truck Side Pad Racks
  - Vehicle Ladder Box Covers
    - Sports Bike Racks, Ski Rack
    - Land Truck Cargo Management, Land Truck Racks
    - Roof Racks, Pro-Rack Roof Racks
    - Truck Box, Truck Storage Boxes
    - Lumber, Lumber, Parkmaster Lumber Lamps
    - Truck Bed Inserts
    - Truck Camera, ProFace Truck Camera
    - Winch Roof Racks
- Truck Bed Cap, Liners, Mats
- Truck Window Visor, Car Window Visors
- Window Vents, Side Window Vents, Side Window Deflection
- Truck Cab Funnels
- Truck Hood Scoops
- Truck Smoke Covers
- Truck Spoilers, Truck Air Ducts
- Truck Rear Valance, Truck Front Valance
- Truck Bumpers, Truck Grille Guards
- Truck Nuts, Truck Hatch Nuts
- Mud Flaps, Stamped Truck Mud Flaps
- Deep Truck Fenders
- Deep Handle, Pro-Truck, Low Handle
- Mud Flaps, Truck Mud Flaps
- Hub Caps
- Treaders, Gull
- Truck Air Compressor, Jeep Air Compressor
- 10M Accessories

Truck Accessory Interior

- GPS Navigation Systems
- Truck Storage Systems, Duffel
- Truck Mats, Truck Floor Mats, SUV Mats, Liners
  - Truck Floor Mats, Cargo Liners by AVS
  - CargoLiner, Mats and Liners
  - Nifty Floor Mats, Nifty Cargo Liners
  - Nifty Floor Mats and Cargo Liners
- Truck Security Systems
- Dash Pad Protectors, Truck Dash Protectors
- Mechanic Wear Gloves
- Air Intakes, Air Intakes
  - Air Intake Induction, Air Intake Induction
  - Volant Air Intake, Volant Exhausts
  - Aural, Aural Air Intake
  - Turbo Jet, Turbo Jet Exhaust
  - K&N, K&N Filters, Air Filter
  - Outlaw Power, Outlaw Diesel Power
- Lift Kits, Rack Lift Kits
- Brake Systems, Truck Brakes
- Diesel Performance
  - Volant Diesel Performance
  - Dingo Diesel Performance, Dingo Performance
  - Predator Diesel Performance, Stear Performance
  - HD Diesel, HD Diesel Power Performance
  - Edelbrock Diesel Exhaust, Edelbrock Diesel Exhaust
  - Edge Diesel Performance Power Systems
  - AEM Diesel Power Air Intake
  - Magnamon Exhaust Systems, Magnamon Cat Back Systems
  - Banks Diesel Power
  - Hypertech Diesel Power Performance
  - Dieselcraft Diesel Exhaust Diesel Filters
  - Bully Dog Diesel Power Performance
- Driveshaft, Driveshaft
- Exhaust Kits, Truck Exhaust Kits
  - Magnamon Exhaust Systems
  - Volant Exhaust Systems

Leveling Kits, Truck Leveling Kits

- Leveling Kits for Truck Firms
  - Front and SUV Leveling Kits by Alynite
  - Truck and SUV Leveling Kit by Falcon
  - Truck and SUV Leveling Kit by RoadPro
  - Truck and SUV Leveling Kit by Air Lift
- RV Leveling System
- RV Levelers, RV Jacks, RV Stabilizers

Landing Hubs, Win Leveling Hubs

- Leveling Kits, Truck, Car Leveling Kits
- Truck Performance, Truck Chops
  - Drabon Sports Performance Systems
  - Air Performance Systems
  - Superolona Performance Systems
  - Unleash Performance Systems
- Shocks, Truck Shocks, Shock Absorbers
- Baskets, Baskets Shocks, Baskets Shock Absorbers
- Suspension Lift Kits, Truck, SUV
  - Superlift Suspension, Superlift Suspension Lift
  - Skyjacker Suspension, Skyjacker Suspension Lift
  - Itze Suspension, Race Suspension Lift
  - Pro Comp Suspension, Pro Comp Suspension Lift
  - Fabtech Suspension, Fabtech Suspension Lift
  - Kriegerman Suspension, Kriegerman Suspension Lift
  - Rancho Suspension, Rancho Suspension Lift
  - RCT Suspension, RCT Suspension Lift
  - Full-Traction Suspension, Full-Traction Suspension Lift
  - Trailmaster Suspension, Trailmaster Suspension Lift
  - Air Lift Suspension, Air Lift Suspension Lift
  - Coil Over Suspension, COILOVER Suspension Lift
  - Calman Suspension, Calman Suspension Lift
  - Full Country Suspension, Full Country Suspension Lift
  - Warner Suspension, Warner Suspension Lift
  - World Demond Suspension, World Demond Suspension Lift
- Air Lift, Air Bag Suspension Lift Kits
- Tires, Off Road Tires, Mud Tires
  - Super Swampy Tires
  - Pro Comp Tires
  - BFG Goodrich Tires
  - Goodyear Tires
  - Goodyear Tires
  - Maxxis Thompson Tires
  - Pirelli Tires
  - Nitto Tires
- Wheel, Truck Wheel, SUV Wheel, Car Wheel
  - Freedom Wheel
  - Maxxis Thompson Wheel
  - Dually Wheel, Dually Truck Wheel
- Winch, Winch, Mile Marker, Ramsey, Superwinch
  - ATV Winch, Snatch Block Winch
  - Dually Winch, Trailer Winch
  - Electric AC Winch
  - Electric AC Winch
  - Winch Mounting System
  - Winch Mounting Plates
- Shop Equipment
- Jeep Accessories, Parts
  - Jeep Top, Jeep Top
- Hammer Accessories, Parts
- Muscle Car, Domestic Accessories, Parts

BR00243

TTAB – STK, LLC v. BACKRACK, INC.  
Cancellation No. 92049332 – Registration No. 3014986

## **EXHIBIT 32**

Search for Products:  go

**FREE SHIPPING!** **On All Orders over \$150**  
Click for Details

**SPECIAL OF THE WEEK MAY 11-17**  
FREE \$50 RESTAURANT GIFT CARD WITH PURCHASE OF SELECT NERF BARS **CLICK FOR DETAILS**

**Family Operated** **WE GUARANTEE WHAT WE SELL**

Browse by Category Below (OR Click for Picture Index)

- Air Filters and Intake Systems
- Antenna
- Bed Liners
- Bed Mats
- Bedside
- Bike Racks - Hitch Carriers
- Billet Grilles
- Bug Shields - Bug Deflectors
- Cargo Accessories
- Carpeted Bed Rugs
- Chips - Computer Enhancers
- Chrome - Polished Accessories
- Diesel Performance
- Du-Ha Storage
- Exhaust - Magnaflo
- Exhaust - MBRP
- Fender Flares - Fender Trim
- Floor Mats - Floor Liners
- Fuel Systems
- Freedom Grille
- Grille Guards
- Grille Inserts
- Headache Racks
- Hood Scoops
- Kien Wheels
- License Plate Frames
- Lighting
- Mud Guards - Mud Flaps
- Nerf Bars - Step Bars
- Rear Air Deflectors
- Roof Racks
- Running Boards
- Shur-Trax Traction Control
- Step Bars - Nerf Bars
- Sunvisors - Moonvisors
- Tail Light Guard
- Tailgate Lock
- Tonneau Covers - Truck Bed Covers
- Towing Mirrors
- Truck and Van Racks
- Truck Bed Covers - Tonneau Covers
- Truck Bed Liners
- Truck Bed Rails
- Vent Visors - Rain Guards - Window Visors
- Winches - Winch Accessories
- Wiper Cows

Headache Rack, BackRack Cab Protection >

HEADACHE RACK

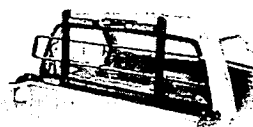

The BACKRACK™ Headache Rack design provides excellent cab protection while providing a sturdy structure to secure cargo, carry ladders and mount a variety of warning lights. This quality product can installed in minutes and requires no drilling on most models. A number of accessories are available for Backrack Headache Racks.

CLICK HERE for more information on Backrack and to select your vehicle make & model

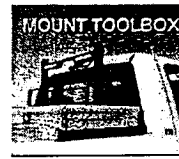
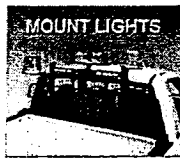
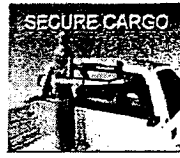

**Truck Champ's Headache Rack Learning Center**

(Click here to [check prices for your vehicle!](#))

**SUFFER NO MORE:**

This rack, mounted at the rear of your truck cab, will prevent a load from shifting or crashing through your rear window.

If you are in the market to buy a one of these products for your truck, the phrase "a picture is worth a thousand words" sums up the situation from the perspective of both function and style. So we hope you will look carefully at Truck Champ's selection of BACKRACK™ Headache Racks that we offer for Chevy/GMC, Dodge, Ford, Isuzu, Mazda, Nissan and Toyota trucks. They are available for midsize and fullsize trucks, all years, with precision fitting and installation hardware. Our attractive products provide outstanding cab protection, safeguarding the rear window and therefore passengers from harm, and they serve as sturdy structures for securing cargo, carrying ladders and mounting a variety of warning lights.

When purchasing from Truck Champ, you will encounter a rare level of customer service and professional expertise gained from our 35 years in the business. Based on

My Shopping Cart



BR00244

our reputation, experience and knowledge, we offer only the highest grade Racks – from BACKRACK – and at reasonable prices. Truck Champ does not offer poorly manufactured products to our customers. Our Headache Racks are fully guaranteed, and you can expect speedy shipment within 24-48 hours from our multiple warehouse locations throughout the U.S. to your address anywhere across the globe. If you need assistance with a purchase, or answers to your questions before or after a purchase, please feel free to call us at 888-244-5908.

**Who Needs Headache Racks?**

The use of this rack is becoming an increasingly popular addition to trucks, adding classy flair. Our BACKRACK Headache Racks are particularly appropriate equipment for owners of fleet vehicles that require safety, durability in all terrains, and accessory brackets that allow mounting of warning and increased visibility lights without drilling through the trucks' roofs. Regular drivers and contractors love BACKRACKS for creating a customized look and greater versatility to their vehicles.

Beyond cab and rear window protection, installation of Headache Racks can cure headaches in the following areas:

**Equipment:** providing a structure for carrying and securing cargo (which prevents shifting), ladders, and other equipment – also toolbox and bedliner friendly.

**Mounting/Accessory Brackets:** structure and accessory brackets create places for warning and spot lights, tool boxes, arrow sticks, and more.

**Designed for Fleet Vehicles:** enables branded customization, easy installation and versatility for fleet vehicles while the steel construction provides the utility and strength required for a multitude of rugged jobs.

**Other Learning Center Topics:**

- [Materials Used to Make the Rack](#)
- [Installation and Accessories for Rack](#)
- [Rack Frequently Asked Questions \(FAQs\)](#)



[Headache Rack, BackRack Cab Protection](#) >

[Home](#) | [Company Info](#) | [Return Policy](#) | [Privacy & Security](#) | [Freight Policy](#) | [Resources](#)

A Division of L.O.F., Inc. Copyright 2005-2008 dba TruckChamp.com  
 Servicing Customers since 1968!  
 For customer service email [CLICK HERE!](#)

or Phone 1-888-244-5908 EST Hours: Mon - Thur 9 AM-7 PM; Fri 9 AM-5:30 PM & Sat. 9 AM to 1 PM  
[BROWSE ALL PRODUCTS](#)



BR00245



TTAB – STK, LLC v. BACKRACK, INC.  
Cancellation No. 92049332 – Registration No. 3014986

## **EXHIBIT 33**

# Pickup Specialties.com

Home Interior Truck Accessories Exterior Truck Accessories Map to our Houston Showroom Contact Us View Cart Checkout My Account Sign In

## BACKRACK HEADACHE RACK FOR TRUCKS



Function and Style for Today's Trucks



Click on Image to Enlarge

**Standard Equipment:** BACKRACKs are fast becoming standard equipment on fleet vehicles across North America. The design of the Back Rack provides versatility to the fleets and individual contractors who use the BackRack for it's function and style. Back Racks can be installed within minutes, and the accessory brackets provide an easy, convenient method of mounting warning lights on to the pickup truck, without having to drill through the roof. Here are some main reasons for to buy BACKRACK.

- easy to install
- no drilling on most models
- durable powdercoat finish
- accessory friendly
- limited lifetime warranty

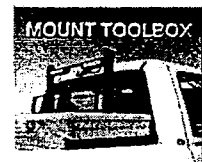
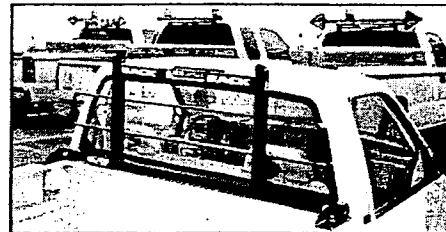

### ORDER YOUR BACKRACK BELOW!

YEAR	MAKE / MODEL	BACKRACK \$229	BackRack w/Tool box Brackets \$239

- Truck Accessories  
[Close Menu](#)
- Find  
Search the Site!
- Scroll down or click on a letter to view all truck accessories alphabetically:
- A B C D E F G H I  
J K L M N O P Q R  
S T U V W X Y Z
- Air Deflector
  - Air Filters
  - Air Purifier
  - Arm Rests
  - Automatic Wipers
  - Awnings and Tents
  - Back Up Cameras & Sensors
  - Bed Caps
  - Bed Covers
  - Bed Extenders
  - Bed Liners
  - Bed Mats
  - Bed Nets | Cargo Nets
  - Bed Organizers
  - Bed Rails
  - Bed Rug
  - Bed Slide
  - Bed Steps
  - Bike Racks
  - Billet Emblems
  - Billet Grilles
  - Billet Pedals
  - Bras
  - Bug Shields
  - Bull Bars
  - Bull Rings
  - Bulls Balls/Truck Nutz
  - Bumpers
  - Bumper Guards
  - Cab Organizers
  - Cab Protectors
  - Cab Spoilers
  - Cab Visors
  - Camper Shells
  - Camper Shell Parts
  - Camper Shell Accessories
  - Car or Pickup Covers
  - Cargo Bars
  - Cargo Carriers
  - Cargo Gates
  - Cargo Nets | BedNets
  - Cargo Organizers
  - Cargo Stops
  - Carports
  - Catalogs
  - Chrome Trim
  - Accessories
  - College Logo Products
  - Consoles
  - Console Vaults
  - Cranes
  - Dash Kits
  - Dash Mats
  - Dash Replacements
  - Diesel Performance

BR00246

<p> <u>Dog Boxes</u>  <u>Door Edge Guards</u>  <u>Door Handles</u>  <u>Door Panels</u>  <u>Down Spoilers</u>  <u>Driving Gloves</u>  <u>Dually Mud Flaps</u>  <u>Duster</u>  <u>Euro Lights</u>  <u>Exhaust Systems</u>  <u>Exhaust Tips</u>  <u>Extend-A-Truck</u>  <u>Fender Flares and Trim</u>  <u>Fiberglass Tonneaus</u>  <u>Floor Liners and Mats</u>  <u>Front Spoilers</u>  <u>Fuel Doors</u>  <u>Fuel Pumps</u>  <u>Garage In A Box</u>  <u>Gas Doors</u>  <u>Gas Savers</u>  <u>Gear Shift Boots</u>  <u>Gift Ideas Under \$50</u>  <u>Gift Ideas \$50-\$100</u>  <u>Glasscapes</u>  <u>GPS Navigation</u>  <u>Systems</u>  <u>Graphics</u>  <u>Grille Inserts</u>  <u>Grille Guards</u>  <u>Gun Console Vaults</u>  <u>Headache Racks</u>  <u>Hitch Balls</u>  <u>Hitch Covers</u>  <u>Hitch Rack</u>  <u>Hitches and</u>  <u>Hitch Accessories</u>  <u>Hitch Steps</u>  <u>Hood Scoops</u>  <u>Hood Shield</u>  <u>iPod Car Accessories</u>  <u>Ladder Racks</u>  <u>Leveling Kits</u>  <u>License Plate Frames</u>  <u>License Plates</u>  <u>Light Bars</u>  <u>Lights</u>  <u>Liquid Transfer Tanks</u>  <u>Loading Ramps</u>  <u>Mirrors and Mirror</u>  <u>Covers</u>  <u>Mud Flaps   Guards</u>  <u>Mufflers</u>  <u>Muffler Resonators</u>  <u>Nerf Bars</u>  <u>Paint Protection</u>  <u>Performance Products</u>  <u>Pickup Cranes</u>  <u>Pop N Lock</u>  <u>Protective Covers</u>  <u>Push Bars</u>  <u>Racks</u>  <u>Rain Tracker</u>  <u>Ramps</u>  <u>Rearview Mirrors</u>  <u>Rocker Panels</u>  <u>Roll n Lock</u>  <u>Roll Pans</u>  <u>Running Boards</u>  <u>Snow Plows</u>  <u>Spare Tire Covers</u>  <u>Splash Guards</u>  <u>Spotlights and</u>  <u>Searchlights</u>  <u>Steering Wheel Covers</u>  <u>Step Shields</u>  <u>Subwoofer Boxes</u>  <u>Subwoofers  </u>  <u>Amplifiers</u>  <u>Sunshades</u> </p>		<b>CHEVY/GMC</b>		
	68-88	Full Size Pick-up, All	10504	10504TB
	88-98	CK Series, Classic Body Style	10503	10503TB
	99-06 and Classic 07	Silverado, Sierra Classic (Old Body Style) <small>Does not fit stepside</small>	10509	10509TB
	2007-Current	Silverado, Sierra (New Body Style)	10519	10519TB
	82-Current	S10-S15, Sonoma	10312	10312TB
	04-Current	Colorado and Canyon	10316	10316TB
		<b>DODGE</b>	<b>BACKRACK \$229</b>	<b>BackRack w/Tool box Brackets \$239</b>
	87-2004	Dakota	10313	10313TB
	2005-Current	Dakota	10314	10314TB
	69-93	Full Size Pick-ups, All	10504	10504TB
	94-01	1500	10507	10507TB
	02 -Current	1500 (new body)	10517	10517TB
	94-02	2500, 3500	10507	10507TB
	03-Current	2500,3500 (new body)	10517	10517TB
		<b>FORD</b>	<b>BACKRACK \$229</b>	<b>BackRack w/Tool box Brackets \$239</b>
	75-96	F-Series 6-1/2 ft bed	10505	10505TB
	75-96	F-Series 8 ft bed	10506	10506TB
	97-03	F150 (except flareside, sportside &	10502	10502TB
	2004-Current	F150 (except flareside, sportside & supercrew)	10512	10512TB
	1999-2003	F150 -Supercrew (no stake pockets)	10502SC	N/A
	2004-Current	F150 Supercrew (no stake pockets)	10512SC	10512SCTB
	99-Current (Including new 2008)	F250/350 - Super Duty	10501	10501TB

BR00247

- [Sunvisors](#)
- [Tailgate Locks and Handles](#)
- [Tailgate Organizer](#)
- [Tailgates and Accessories](#)
- [Tailgating Gear](#)
- [Taillight Covers](#)
- [Tents](#)
- [Third Brake Lights](#)
- [Tie Downs](#)
- [TireGate Spare Tire Carrier](#)
- [Tonneau Covers](#)
- [Tool Boxes](#)
- [Towing Accessories](#)
- [Trailer Hitches](#)
- [Trailers - Boat and Utility](#)
- [Transfer Tanks](#)
- [Truck Bed Covers](#)
- [Truck Bed Liners | Mats](#)
- [Truck Bed Organizers](#)
- [Truck Covers Custom Fit](#)
- [Truck Covers Universal](#)
- [Truck Nuts | Bulls Balls](#)
- [Truck Steps](#)
- [Truck Tents](#)
- [Truck Toppers](#)
- [Truck Vault](#)
- [Under Seat Storage](#)
- [Vehicle Shelters](#)
- [Ventvisors](#)
- [Vinyl/Fabric Protectant and Cleaner](#)
- [Winches](#)
- [Window Graphics](#)
- [Window Visors](#)
- [Wiper Cowl](#)
- 
- [About Us](#)
- [Join Our Mailing List](#)
- [Truck Accessories Blog](#)
- [Garage Sale](#)
- [Gift Ideas!](#)
- [Guarantee](#)
- [Links](#)
- [Photo Gallery](#)
- [Returns](#)
- [Shipping](#)
- [Testimonials](#)
- [Tracking](#)
- [Sitemap](#)

93-Current	Ranger	10311 <a href="#">Buy Now</a>	10311TB <a href="#">Buy Now</a>
	<b>ISUZU</b>	<b>BACKRACK \$229</b>	<b>BackRack w/Tool box Brackets \$239</b>
91-2004	Rodeo	10312 <a href="#">Buy Now</a>	10312TB <a href="#">Buy Now</a>
	<b>MAZDA</b>	<b>BACKRACK \$229</b>	<b>BackRack w/Tool box Brackets \$239</b>
89-92	B-Series	10310 <a href="#">Buy Now</a>	10310TB <a href="#">Buy Now</a>
93-Current	B-Series	10311 <a href="#">Buy Now</a>	10311TB <a href="#">Buy Now</a>
	<b>NISSAN</b>	<b>BACKRACK \$229</b>	<b>BackRack w/Tool box Brackets \$239</b>
87-2004	Pick-up & Frontier	10312 <a href="#">Buy Now</a>	10312TB <a href="#">Buy Now</a>
2005-Current	Frontier	10314 <a href="#">Buy Now</a>	10314TB <a href="#">Buy Now</a>
2004-Current	Titan	10511 <a href="#">Buy Now</a>	10511TB <a href="#">Buy Now</a>
	<b>TOYOTA</b>	<b>BACKRACK \$229</b>	<b>BackRack w/Tool box Brackets \$239</b>
84-98	Pick-up	10310 <a href="#">Buy Now</a>	10310TB <a href="#">Buy Now</a>
93-98	T-100	10508 <a href="#">Buy Now</a>	10508TB <a href="#">Buy Now</a>
97-2004	Tacoma	10313 <a href="#">Buy Now</a>	10313TB <a href="#">Buy Now</a>
2005-Current	Tacoma	N/A (no rack available)	N/A (no rack available)
1999-2005	Tundra	10508 <a href="#">Buy Now</a>	10508TB <a href="#">Buy Now</a>
2007-Current	Tundra	10518 <a href="#">Buy Now</a>	10518TB <a href="#">Buy Now</a>

[View Cart](#) [Checkout](#)

BR00248

### BackRack Rear Bar



#### Rear Bar

Carry ladders and other long items on the Safety Rack with the accessory Rear Bar. It simply drops into the rear stake pockets of the truck and allows you to open and close the tailgate without interference.

[Click Here to see BackRack Rear Bar.](#)

[Click Here to see all Optional BackRack Accessories](#)

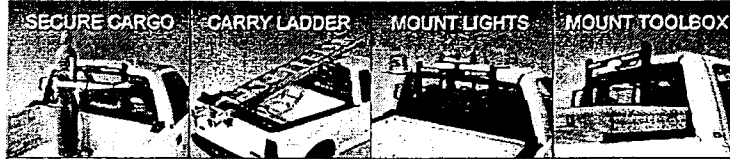

**NEW PRODUCT!**

[Click Here for BackRack Safety Lights!](#)

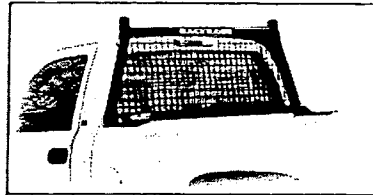

[Click Here to See the BackRack Safety Rack!](#)

Our online ordering system will keep all information provided completely secure using SSL encryption technology. Additionally, All information provided by you will be completely confidential. Pickup Specialties does not provide customer information, mailing list or other data to any outside firms or individuals.



[Home](#)   [Interior Truck Accessories](#)   [Exterior Truck Accessories](#)   [Map to our Houston Showroom](#)   [Contact Us](#)   [View Cart/Checkout](#)   [Order Status](#)

BR00249

TTAB – STK, LLC v. BACKRACK, INC.  
Cancellation No. 92049332 – Registration No. 3014986

## **EXHIBIT 34**



Home

Search

Take it on the road

Information

View Cart

Search Cargo Gear:

Go

Featured Gear  
(all gear pages)

- Tonneau Covers
- Truck Racks
- Bike Racks
- Ramps
- Nets
- Organizers
- Straps & Tiedowns
- Travel Gear
- Towing
- Bed Accessories
- What's New
- Shop by Brand  
(see all brands)
- Shop by Category  
(see all categories)
- Popular Categories:
- Truck Racks
- Truck Bed Covers
- Hitch Bike Racks
- Car Organizers
- Roof Cargo Bags
- Truck Nets
- Rubber Bed Mats
- Travel Storage
- ATV Cargo Nets
- Online Catalog
- Browse catalog
- Specials
- Sale Page
- Closeouts
- Newsletter Sign Up
- Cargo Gear Recycles

Recommended Truck Racks at CargoGear:

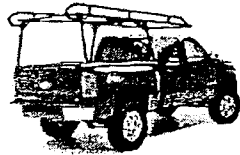

Smittybilt Contractor Rack  
\$419 free shipping



Thule Xsporter Rack  
\$494.10 free shipping

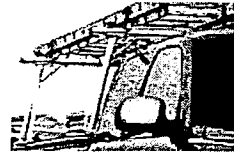

TracRac Truck Rack  
\$749 free shipping



Light Duty Van Rack  
\$51.95

BackRack Truck Racks

Headache racks, safety racks, and BackRack™ accessories.

Click the Quick Links On this page:

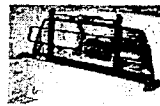

Original BackRack™

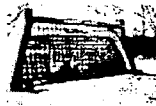

Safety Rack



Toolbox Brackets



BackRack Rear Bar



Accessory Brackets

BackRack™ Headache Rack

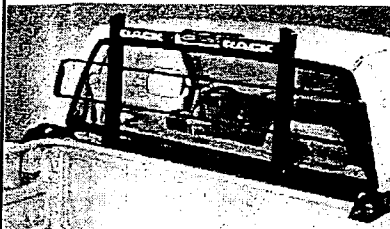

NO DRILL LIFETIME WARRANTY FREE SHIPPING



(See all BackRack photos)

- Provides cab protection from shifting cargo in the truck bed.
- Rack is a sturdy anchor point for tiedown straps, ropes, bungees, etc.
- Rugged 2" x 2" steel tube construction & durable black powdercoat finish.
- Rack mounts in truck stake pockets without drilling. Easy to install.
- Great for commercial or fleet trucks - carry lumber, pipe, more.
- Use as a base for accessories: emergency lights, antenna, toolbox, etc.
- Bedliner and toolbox friendly, rack is available with toolbox brackets.
- Leaves third brake light on cab visible - important for safety.
- Choose regular mounting brackets or 21" toolbox brackets. Toolbox brackets allow for easy installation of over-the-rail style toolbox.
- Applications for many pickups - click "Order Now" to order for your truck.

BackRack with Toolbox Brackets - \$299.95

BackRack with Regular Brackets - \$289.95

BackRack™ Safety Rack

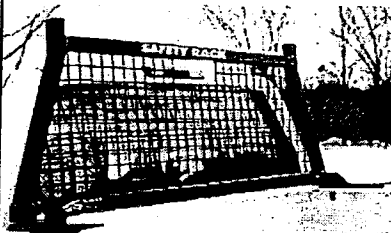

NO DRILL LIFETIME WARRANTY FREE SHIPPING



(See all BackRack photos)

- Provides complete cab protection from shifting cargo in the truck bed.
- Rugged 2" x 2" steel tube & 3/16" wire welded on 2" centers.
- Precision welded steel construction with durable black powdercoat finish.
- Rack mounts in truck stake pockets without drilling. Easy to install.
- Great for commercial or fleet trucks - carry lumber, pipe, more.
- Use as a base for accessories: emergency lights, antenna, toolbox, etc.
- Bedliner and toolbox friendly, rack is available with toolbox brackets.
- Leaves third brake light on cab visible - important for safety.
- Choose regular mounting brackets or 21" toolbox brackets. Toolbox brackets allow for easy installation of over-the-rail style toolbox.
- Applications for many pickups - click "Order Now" to order for your truck.

Safety Rack with Toolbox Brackets - \$319.95

BR00250

Safety Rack with Regular Brackets- \$309.95 [Order Now](#)

### BackRack™ Toolbox Brackets



- Easily install an over-the-rail style toolbox with your BackRack. Brackets are 21" long.
- Toolbox Brackets mount in truck stake pockets and bolt on to BackRack or Safety Rack.
- Toolbox Brackets work only in combination with BackRack and Safety Rack. Check the part number of your rack and find it below to order the correct toolbox brackets.

(See all BackRack photos)

21" long BackRack Toolbox Brackets - \$37.95

#### Toolbox Brackets for most Fullsize pickups

[Order Now](#)

Fits BackRack part #: 10503, 10504, 10505, 10506, 10507, 10508, 10509, 10311, 10517, and corresponding Safety Racks.

#### Toolbox Brackets for most Compact/Midsize pickups

[Order Now](#)

Fits BackRack part #: 10310, 10312, 10313, 10502SC, 10512SC and corresponding Safety Racks.

#### Toolbox Brackets for Ford SuperDuty 1999-2008

[Order Now](#)

Fits BackRack part #: 10501US, 40501.

#### Toolbox Brackets for Ford F-150 2004-2008

[Order Now](#)

Fits BackRack part #: 10512, 40512

#### Toolbox Brackets for Ford F-150 1997-2003

[Order Now](#)

Fits BackRack part #: 10502, 40502.

### BackRack™ Rear Bar



BackRack™ Rear Tailgate Bar - \$119.95

- Provides anchor point to secure long cargo like ladders, lumber, or pipe.
- Works with BackRack™ or Safety Rack, same steel construction and finish.
- Easy No Drill installation in stake pockets. Easy to remove when not in use.
- Each bar is designed to work with specific pickup truck models (must have stake pockets).

(See all BackRack photos)

Chevy/GMC Silverado/Sierra, 1999-2006	Order	Ford F-150, 2004-2008	Order
Chevy/GMC C/K Series, 1988-1998	Order	Ford SuperDuty, 1999-2008	Order
Chevy/GMC Fullsize Pickup, 1968-1987	Order	Ford F-150, 1997-2003	Order
Dodge Ram, 2002-2008	Order	Ford F-Series Shortbed, 1975-1996	Order
Dodge Ram, 1994-2001	Order	Ford F-Series Longbed, 1975-1996	Order
Ford Ranger, 1982-2008	Order	Toyota Tundra/T100, 1999-2006	Order

### BackRack™ Accessory Brackets



- BackRack Accessory Brackets are constructed of steel with black powdercoat finish.
- All brackets bolt on to the BackRack™ with included hardware, Do Not require Drilling, and work with both BackRack™ and Safety Rack. (unless otherwise noted.)

(See all BackRack and Accessory photos)

#### Folding Bracket for Round Strobe Lights - 71.95

#### Regular Bracket for Round Strobe Lights - 49.95



Drivers side, 10.5" base

[Order Now](#)

Passenger side, 10.5" base

[Order Now](#)

- Bracket rotates 180 degrees.
- Light can be stored upside down.



Drivers side, 10.5" base

[Order Now](#)

Passenger side, 10.5" base

[Order Now](#)

Center Mount, 10.5" base

[Order Now](#)

Drivers side, 6.5" base

[Order Now](#)

BR00251



Passenger side, 6.5" base [Order Now](#)

**Bracket for Rectangular lights/mini bars -49.95**



Side Mount, 16" x 7" [Order Now](#)

Center Mount, 16" x 7" [Order Now](#)

**Brackets for Sport Lights - 33.95** [Order Now](#)



- Pair of "L" brackets.
- For sport lights, fog lights, or driving style lights.

**Brackets for Light Bars - 49.95** [Order Now](#)



- Pair of Heavy Duty "L" Brackets.
- For fullsize "police style" light bars.

**Brackets for Arrow Sticks - 49.95** [Order Now](#)



- Pair of brackets and self-tapping screws.
- Requires some drilling.

**Antenna Bracket - 35.95** [Order Now](#)



- 3.5" square base.
- Pre-Drilled 7/8" antenna mounting hole.

**Universal Light Bracket - 47.95** [Order Now](#)

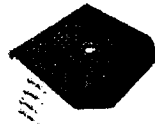

- 10.5" square base, self-tapping screws.
- Requires some drilling.
- Does not work with Safety Racks for Dodge Ram, 1994-2001

**Related Truck Rack Items at CargoGear:**

[TracRac Truck Racks](#) - Aluminum alloy Truck Racks and Van Racks.

[T-Rac Pro Removable Truck Rack](#) - TracRac brand removable aluminum truck rack.

**Browse the Catalog Pages:**

[Racks, Bike Racks  
Rack Accessories](#)

[Tonneaus, Ramps  
Bed Accessories](#)

[Straps, Tiedowns  
Anchor Points](#)

[Organizers, Nets  
Carriers](#)

[Towing, Tools  
Hardware](#)

[Order Status](#)

[Links We Like](#)

[Privacy Policy](#)

[Shipping and Returns](#)

[Contact Us](#)

**Thank you for shopping at CargoGear!**

Please see our [CargoGear Information Page](#) for details on ordering, shipping, and our respect for your privacy. Call CargoGear toll-free: 1.866.792.6614 email: [info@cargogear.com](mailto:info@cargogear.com)



© Copyright 1999-2007 by Saris Corp. [cargogear.com](http://cargogear.com), [cargogear.net](http://cargogear.net), and  are Trademarks of Saris Corp. Questions or comments, send an email to: [info@cargogear.com](mailto:info@cargogear.com)

BR00252

TTAB – STK, LLC v. BACKRACK, INC.  
Cancellation No. 92049332 – Registration No. 3014986

## **EXHIBIT 35**

Car, Truck, Van and SUV Racks for Sports and Utility Use. | Site Map

FREE Shipping\* on purchases over \$50 | More

Enter Search   Customer Care | Track Your Order | View Cart

Home Bicycle Racks Kayak & Canoe Racks Ski & Snowboard Racks Surf & Windsurf Racks Ladder & Construction Racks Luggage & Sports Bags

May 14, 2008

BackRack Cab Protector >

Shopping Cart

Items in your Cart: 0  
Current Subtotal: \$0.00



- or use -



Fast checkout through Google

[Clear Cart](#) | [View Cart](#)

Ordering Made Easy!

Not sure which rack & accessories you need to fit a specific vehicle? Use our fit guides to find your system and order.



The BackRack Rear Window Protector Headache Rack is attractively constructed with black powder coated steel bar stock and tubing.

Products

Displaying products 1 - 7 of 7 results

Items: - Sort: -



Featured Brands:

Sports Racks

- [Thule Rack Products >](#)
- [Yakima Rack Products >](#)
- [Allen Bicycle Racks >](#)
- [Mirage Truck Rack >](#)
- [Rack & Roll Trailers >](#)
- [Sports Solutions Storage >](#)
- [Rocky Mounts Bike Racks >](#)
- [Sport Rack Gear Carriers >](#)
- [Steel Core Security Straps >](#)
- [Inno Ski & Snowboard Racks >](#)
- [All Sport Rack Brands >](#)

Utility Racks

- [TracRac Utility Rack Products >](#)
- [SystemOne Utility Racks >](#)
- [BackRack Cab Protector >](#)
- [Thule Pro Utility Racks >](#)
- [Weather Guard Utility Racks >](#)
- [Vanguard Utility Racks >](#)
- [Hauler Utility Rack Products >](#)
- [Karrite Utility Racks >](#)
- [All Utility Rack Brands >](#)

Luggage & Bags

- [Bunro Snowboard Bags >](#)
- [CameiBak Hydration Systems >](#)
- [High Sierra Bags >](#)
- [Marker Ski Bags >](#)
- [Pelican Waterproof Cases >](#)



[View Product](#)  
 Free Rack Warehouse 9' Heavy-Duty, Cam Buckle, Tie down Straps with BackRack or Safety Rack Purchase  
 List Price ~~\$22.00~~  
**Our Price \$0.00**



[View Product](#)  
 BackRack Window Guard Headache Rack, Free Tiedowns with Purchase  
 List Price ~~\$262.00~~  
**Our Price \$235.80**



[View Product](#)  
 BackRack Window Guard with Toolbox Mounting Kit, Free Tiedowns with Purchase  
 List Price ~~\$271.00~~  
**Our Price \$243.90**



[View Product](#)  
 BackRack Safety Rack Window / Cab Guard, Free Tiedowns with Purchase  
 List Price ~~\$312.00~~  
**Our Price \$280.80**



[View Product](#)  
 BackRack Center Mounted Safety Light Brackets  
 List Price ~~\$49.00~~  
**Our Price \$44.10**



[View Product](#)  
 BackRack Corner Mounted Safety Light Brackets  
 List Price ~~\$49.00~~  
**Our Price \$44.10**



[View Product](#)  
 BackRack Antenna Mounting Bracket

BR00253

Tecnica Ski Bags ▶  
Victorinox Swiss Army ▶  
Volkl Ski Bags ▶

List Price ~~\$49.00~~  
Our Price **\$44.10**  
[Add To Cart](#)

**Popular Categories**

Bike Racks ▶  
Roof Racks ▶  
Car Racks ▶  
Kayak & Canoe Racks ▶  
Ladder & Construction Racks ▶  
Luggage & Sport Bags ▶  
Ski & Snowboard Bags ▶  
Ski & Snowboard Racks ▶  
Ski, Snowboard Bag Brands ▶  
Sport Rack Manufacturers ▶  
Surfboard, Windsurfer Racks ▶  
Specially Racks & Carriers ▶  
Utility, Construction & Work  
Rack Manufacturers ▶

[Home](#) [Best Price Promise](#) [About Us](#) [Customer Care](#) [Corporate Sales](#) [Contact Us](#) [Links](#) [FAQ's](#) [Fit Guides](#) [Track Your Order](#)

Call us Toll-Free: 1-800-272-5362



copyright © 1994-2008 The Rack Warehouse Inc. All Rights Reserved.

[Browse all Products](#)

BR00254

TTAB – STK, LLC v. BACKRACK, INC.  
Cancellation No. 92049332 – Registration No. 3014986

## **EXHIBIT 36**



**Product Search**

by keyword

by part number

Advanced Search  
Browse by Category  
Browse by Vendors



**Catalog Lookup**

Type in a part number from our print catalog to see pricing or go advanced!

**Mailing List**

Submit your e-mail address to subscribe to our monthly newsletter.

**Information**

OK Auto, 4wd & Tire  
2621 State Route 57  
Stewartsville, NJ 08886

908-454-6973  
M-W, Fri 8:30-6, Thurs 8:30-7, Sat 9-2 EST

Leave Feedback

This site is hosted by:

> Categories > Truck Bed Accessories > Headache Racks > Vendors > Backrack > Headache Racks >

**BACKRACK Backrack Headache Rack**

The design of the Backrack headache rack for pickup trucks provides versatility to the fleets and individual contractors who use the Backrack for it's function and style. The Backrack can be installed within minutes, and the accessory brackets provide an easy, convenient method of mounting warning lights on to the pickup truck, without having to drill through the roof. Works with tool a box.

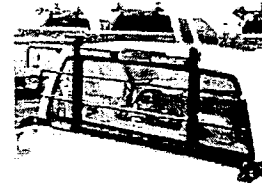

[More Product Images](#)

- easy to install
- no drilling on most models
- durable powdercoat finish
- accessory friendly
- limited lifetime warranty

10310	87-96 Dodge Dakota, 89-92 Mazda B-Series, 84-98 Toyota Pick-up	\$249.95	1	<a href="#">Add</a>
10310TB	87-96 Dodge Dakota, 89-92 Mazda B-Series, 84-98 Toyota Pick-up w/ Toolbox	\$249.95	1	<a href="#">Add</a>
10311	93-04 Ford Ranger, 93-04 Mazda B-Series	\$249.95	1	<a href="#">Add</a>
10311TB	93-04 Ford Ranger, 93-04 Mazda B-Series w/ Toolbox	\$249.95	1	<a href="#">Add</a>
10312	82-04 Chev/GMC S10-S15, Sonoma, 91-04 Isuzu Rodeo, 87-04 Nissan Pick-up & Frontier	\$249.95	1	<a href="#">Add</a>
10312TB	82-04 Chev/GMC S10-S15, Sonoma, 91-04 Isuzu Rodeo, 87-04 Nissan Pick-up & Frontier w/ Toolbox	\$249.95	1	<a href="#">Add</a>
10313	97-04 Dodge Dakota, 97-04 Toyota Tacoma	\$249.95	1	<a href="#">Add</a>
10313TB	97-04 Dodge Dakota, 97-04 Toyota Tacoma w/ Toolbox	\$249.95	1	<a href="#">Add</a>
10501	99-04 Ford Superduty	\$249.95	1	<a href="#">Add</a>
10501TB	99-04 Ford Superduty w/ Toolbox	\$249.95	1	<a href="#">Add</a>
10501US	99-04 Ford Superduty w/ Short Top Posts	\$249.95	1	<a href="#">Add</a>
10502	97-03 Ford F150, F250 Light Duty (and 2004)	\$249.95	1	<a href="#">Add</a>
10502TB	97-03 Ford F150, F250 Light Duty (and 2004) w/ Toolbox	\$249.95	1	<a href="#">Add</a>
10503	88-98 Chev/GMC CK Series, Classic Body Style	\$249.95	1	<a href="#">Add</a>
10503TB	88-98 Chev/GMC CK Series, Classic Body Style w/ Toolbox	\$249.95	1	<a href="#">Add</a>
10504	68-88 Chev/GMC, 69-93 Dodge Full Size Pick-up, All	\$249.95	1	<a href="#">Add</a>
10504TB	68-88 Chev/GMC, 69-93 Dodge Full Size Pick-up, All w/ Toolbox	\$249.95	1	<a href="#">Add</a>
10505	75-96 Ford F-Series 6.5 ft bed	\$249.95	1	<a href="#">Add</a>

BR00255

10505TB	75-96 Ford F-Series 6.5 ft bed w/ Toolbox	\$249.95	1	<input type="button" value="Add"/>
10506	75-96 Ford F-Series 8 ft bed	\$249.95	1	<input type="button" value="Add"/>
10506TB	75-96 Ford F-Series 8 ft bed w/ Toolbox	\$249.95	1	<input type="button" value="Add"/>
10507	94-01 Dodge 1500, 94-02 Dodge 2500, 3500	\$249.95	1	<input type="button" value="Add"/>
10507TB	94-01 Dodge 1500, 94-02 Dodge 2500, 3500 w/ Toolbox	\$249.95	1	<input type="button" value="Add"/>
10508	93-98 Toyota T-100, 99-04 Toyota Tundra	\$249.95	1	<input type="button" value="Add"/>
10508TB	93-98 Toyota T-100, 99-04 Toyota Tundra w/ Toolbox	\$249.95	1	<input type="button" value="Add"/>
10509	99-04 Chev/GMC Silverado, Sierra (New Body Style) DW	\$249.95	1	<input type="button" value="Add"/>
10509TB	99-04 Chev/GMC Silverado, Sierra (New Body Style) DW w/ Toolbox	\$249.95	1	<input type="button" value="Add"/>
10512	2004 Ford F150	\$249.95	1	<input type="button" value="Add"/>
10512TB	2004 Ford F150 w/ Toolbox	\$249.95	1	<input type="button" value="Add"/>
10517	02-04 Dodge 1500, 03-04 Dodge 2500, 3500 (new body)	\$249.95	1	<input type="button" value="Add"/>
10517TB	02-04 Dodge 1500, 03-04 Dodge 2500, 3500 (new body) w/ Toolbox	\$249.95	1	<input type="button" value="Add"/>

If you can't find what you're looking for on our web site, please give us a call at 908-454-6973.

Copyright © 2007 OK Auto, 4wd & Tire, Inc. All Rights Reserved.

BR00256

TTAB – STK, LLC v. BACKRACK, INC.  
Cancellation No. 92049332 – Registration No. 3014986

## **EXHIBIT 37**