

ESTTA Tracking number: **ESTTA34984**

Filing date: **06/06/2005**

IN THE UNITED STATES PATENT AND TRADEMARK OFFICE  
BEFORE THE TRADEMARK TRIAL AND APPEAL BOARD

<b>Proceeding</b>	91165017
<b>Party</b>	Defendant Napster, LLC Napster, LLC 455 El Camino Real Santa Clara, CA 95050
<b>Correspondence Address</b>	Allyn Taylor DLA Piper Rudnick Gray Cary US LLP 2000 University Avenue East Palo Alto, CA 94303-224
<b>Submission</b>	Motion to Suspend for Civil Action
<b>Filer's Name</b>	Michael T. Zeller
<b>Filer's e-mail</b>	michaelzeller@quinnemanuel.com
<b>Signature</b>	/Michael T. Zeller/
<b>Date</b>	06/06/2005
<b>Attachments</b>	PetitionforStay.pdf ( 7 pages ) DeclarationPart1.pdf ( 179 pages ) DeclarationPart2.pdf ( 111 pages )

IN THE UNITED STATES PATENT AND TRADEMARK OFFICE  
BEFORE THE TRADEMARK TRIAL AND APPEAL BOARD

In the Matter of:

Trademark Reg. No. 78414770  
Registration Date: March 29, 2005  
For the Mark: NAPSTER LIGHT

---

SIGHTSOUND TECHNOLOGIES, INC.,

*Opposer,*

v.

NAPSTER, L.L.C.,

*Applicant.*

Opposition No. 91165017

**APPLICANT'S PETITION FOR STAY**

Commissioner of Trademarks  
P.O. Box 1451  
Arlington, Virginia 22313-1451

Applicant Napster, LLC (“Applicant” or “Registrant”), by its counsel, respectfully moves the Board to stay the instant proceedings pending the resolution of issues raised by Opposer SightSound Technologies, Inc. (“Opposer”) in its Opposition that are also currently before the United States Bankruptcy Court for the District of Delaware and the United States District Court for the Western District of Pennsylvania.

In support of its Motion, Applicant states as follows. In these proceedings, SightSound opposes the registration of the mark NAPSTER LIGHT (the “Registration”). According to Opposer, this Opposition “is related to...Cancellation No. 92044347,” in which the Opposer here is seeking the cancellation of four issued NAPSTER registrations. See Opposition at 1.<sup>1</sup> Applicant filed a Petition for Stay in Cancellation No. 92044347 on May 24, 2005. (Zeller Decl., Exh. 2.) The Petition for Stay was also served on Opposer on May 24, 2005. (Id., ¶ 2.) As with the cancellation proceedings, there are pending court actions that may bear on the issues raised by the Opposition and therefore warrant the entry of a stay of these opposition proceedings until their resolution by the courts.

First, on June 3, 2002, Napster, Inc. and its subsidiaries (collectively, “Napster, Inc.”) filed voluntary petitions for relief under Chapter 11 of Title 11 of the United States Code in the Bankruptcy Court of the District of Delaware (the “Bankruptcy Court”).<sup>2</sup> An Asset Purchase Agreement was entered into on November 15, 2002 between Napster, Inc. and Roxio, Inc. (“Roxio”), which is Applicant’s parent. The Asset Purchase Agreement provided for Roxio’s acquisition of substantially all of Napster, Inc.’s tangible and intangible assets, including all

---

<sup>1</sup> Opposer’s Petition for Cancellation No. 92044347 is attached as Exhibit 1 to the Zeller Declaration (“Zeller Decl.”) submitted herewith.

<sup>2</sup> The facts stated herein are supported by and set forth in greater detail in the Motion to Reopen Chapter 11 Case and Enforce Sale Order and its accompanying exhibits. (Zeller Decl., Exh. 3.)

NAPSTER marks and their associated good will as well as issued registrations and then-pending Intent-to-Use applications. On November 27, 2002, after notice and a lengthy hearing at which multiple parties appeared, the Bankruptcy Court entered a Sale Order approving the Asset Purchase Agreement.

The Petition for Cancellation No. 92044347 is predicated on the alleged invalidity of the assignment of trademark rights that had been accomplished in the Bankruptcy Court, pursuant to the Bankruptcy Court's Sale Order on November 27, 2002. See Petition, ¶¶ 5, 7-8. The current Opposition is based on the same grounds. See Opposition, ¶ 5. Because of Opposer's attack on the validity of the Bankruptcy Court's Sale Order -- and the Asset Purchase Agreement that the Court's Order approved -- Applicant and Roxio filed a Motion to Reopen Chapter 11 Case and Enforce Sale Order (the "Motion") on May 20, 2005 in the Bankruptcy Court. (Zeller Decl., Exh. 3.) The Motion was served on Opposer herein on May 20, 2005. (Id., ¶ 3.) Among other things, the Motion seeks to reopen the Bankruptcy Court proceeding and seeks an Order by the Bankruptcy Court enforcing the terms of the Sale Order, including with respect to the NAPSTER registrations at issue in the Petition for Cancellation. (Zeller Decl., Exh. 3, at 14-19.) As a result, the validity of the assignment that Opposer challenges in these opposition proceedings is likewise at issue in the Motion before the Bankruptcy Court. (Id.)

Second, issues raised by the Opposition are also the subject of another pending civil action between the parties. On January 25, 2005, Opposer sued Applicant and Roxio in the United States District Court for the Western District of Pennsylvania (the "District Court") in an action for ostensible patent infringement entitled *SightSound Technologies, Inc. v. Roxio, Inc. and Napster, L.L.C.*, Case No. 04-1549. (Zeller Decl., Exh. 4.) Applicant and Roxio filed an

Answer and Counterclaims, as well as a First Amended Answer and Counterclaims. (Id., Exh. 5.) The Fourth through Ninth Counterclaims for Relief allege, among other things, that Opposer's issuance of a press release stating that the Napster "name" is "synonymous with the most well-known violation of intellectual property rights" constituted unfair competition, trade libel, defamation, commercial disparagement, breach of contract and intentional interference with prospective contractual relations. (Id.) Although the action in the District Court is currently stayed pending the Patent Office's re-examination of the patents asserted by Opposer in the District Court suit, the action remains pending before the District Court. (Zeller Decl., ¶ 5.)

The Opposition reveals that it overlaps with, and duplicates, issues that are pending before the District Court. The Opposition asserts that Applicant's Counterclaims in the District Court "allegedly aris[e] from Opposer's reference to the name Napster" and thus relies on Applicant's Counterclaims as a basis for rejection here. Opposition, ¶¶ 2, 4. Furthermore, Opposer filed with the District Court on February 11, 2005 a motion to dismiss that puts at issue, in largely identical language, matters asserted in the Opposition. Thus, Opposer's motion to dismiss recites the same allegations that Opposer makes in paragraph 3 of the Opposition. (Zeller Decl., Exh. 6, at 1-2.) Furthermore, Opposer's motion to dismiss presents to the District Court precisely the same assignment-in-gross arguments that are alleged in paragraphs 4 and 5 of the Opposition. (Zeller Decl., Exh. 6, at 7-8.)<sup>3</sup>

Because the issues currently pending before the Bankruptcy Court and the District Court may have an effect on issues raised in the Opposition, the instant proceedings should be stayed pending the courts' determinations. The Board's usual practice of staying its proceedings

---

<sup>3</sup> The District Court has not yet ruled on Opposer's motion to dismiss in those proceedings. (Zeller Decl., ¶ 6.)

pending the outcome of a civil action that may have a bearing on the issues before the Board, as is the situation here, is codified at 37 C.F.R. § 2.117(a):

“Whenever it shall come to the attention of the Trademark Trial and Appeal Board that a party or parties to a pending case are engaged in a civil action or another Board proceeding which may have a bearing on the case, proceedings before the Board may be suspended until termination of the civil action or other Board proceeding.”

See Trademark Trial and Appeal Board Manual of Procedure § 510.02(a) (“[o]rdinarily, the Board will suspend proceedings in the case before it if the final determination of the other proceeding will have a bearing on the issues before the Board.”). See also The Other Telephone Co. v. Connecticut Nat’l Telephone Co., 181 U.S.P.Q. 779, 781-82 (Comm’r of Patents 1974); Townley Clothes, Inc. v. Goldring, Inc., 100 U.S.P.Q. 57, 58 (Comm’r of Patents 1953) (“it is deemed the sounder practice to suspend the [Trademark] Office proceedings pending termination of the Court action.”).

The most logical and efficient course of action here is to suspend these proceedings until the Bankruptcy Court and the District Court resolve the issues that Opposer also asserts here. Applicant respectfully requests that its motion be granted and that the instant opposition proceedings be suspended pending the completion of the relevant proceedings before the Bankruptcy Court and before the District Court.

Respectfully submitted,

Dated: June 6, 2005

By: Michael T. Zeller

QUINN EMANUEL URQUHART  
OLIVER & HEDGES, LLP  
Michael T. Zeller  
Michael E. Williams  
865 South Figueroa Street, 10th Floor  
Los Angeles, California 90017  
Telephone: (213) 443-3000  
Facsimile: (213) 443-3100

*Attorneys for Applicant  
Napster, LLC*

Proof of Service

I hereby certify that a true and complete copy of the foregoing Respondent and Registrant Napster, LLC's Petition for Stay has been served on William K. Wells by mailing said copy on June 6, 2005, via First Class Mail, postage prepaid to:

William K. Wells  
Brian S. Mudge  
Susan A. Smith  
KENYON & KENYON  
1500 K Street, N.W., Suite 700  
Washington, DC 20005  
Tel.: (202) 220-4200  
Fax: (202) 220-4201



---



**IN THE UNITED STATES PATENT AND TRADEMARK OFFICE  
BEFORE THE TRADEMARK TRIAL AND APPEAL BOARD**

In the Matter of:

Trademark Reg. No. 78414770  
Registration Date: March 29, 2005  
For the Mark: NAPSTER LIGHT

Opposition No. 91165017

---

SIGHTSOUND TECHNOLOGIES, INC.,

*Opposer,*

v.

NAPSTER, L.L.C.,

*Applicant.*

---

**DECLARATION OF MICHAEL T.  
ZELLER IN SUPPORT OF  
APPLICANT'S PETITION FOR STAY**

Commissioner of Trademarks  
P.O. Box 1451  
Arlington, Virginia 22313-1451

I, Michael T. Zeller, do hereby declare and state as follows:

1. I am a member of the State Bars of California, New York and Illinois and am counsel for Napster, LLC in these proceedings and for Napster, LLC and Roxio, Inc. in *SightSound Technologies, Inc. v. Roxio, Inc., and Napster, L.L.C.*, Civil Action No. 04-1549 (W.D. Pa.), and *In re: Enco Recovery Corp. f/k/a/ Napster, Inc.*, No. 02-11573 (PJW) (Bankr. D. Del.). I have personal knowledge of the facts stated herein and, if sworn as a witness, could and would testify competently thereto.

2. According to Opposer, the current Opposition is related to Opposer's Petition for Cancellation No. 92044347, which seeks the cancellation of four issued NAPSTER registrations. A true and correct copy of the Petition for Cancellation No. 92044347 is attached hereto as Exhibit 1. Applicant filed a Petition for Stay of the Cancellation proceedings on May 24, 2005. The Petition for Stay was also served on Opposer on May 24, 2005. A true and correct copy of the Petition for Stay is attached hereto as Exhibit 2.

3. On May 20, 2005, Applicant and Roxio filed a Motion to Reopen Chapter 11 Case and Enforce Sale Order ("the Motion") in *In re: Enco Recovery Corp. f/k/a/ Napster, Inc.* A true and correct copy of the Motion and its accompanying exhibits are attached hereto as Exhibit 3. The Motion was served on Petitioner herein on May 20, 2005. Among other things, the Motion seeks to reopen the Bankruptcy Court proceedings and seeks an Order by the Bankruptcy Court enforcing the transfer of assets, including with respect to the NAPSTER registrations at issue in the Petition for Cancellation. As a result, the validity of the assignment that Opposer in these proceedings is also at issue in the Motion before the Bankruptcy Court.

4. On January 25, 2005, Petitioner sued Respondent and Roxio in the United States District Court for the Western District of Pennsylvania (the “District Court”) in an action for ostensible patent infringement entitled *SightSound Technologies, Inc. v. Roxio, Inc. and Napster, L.L.C.*, Case No. 04-1549. A true and correct copy of the Complaint in that action is attached hereto as Exhibit 4. Respondent and Roxio filed an Answer and Counterclaims, as well as a First Amended Answer and Counterclaims. A true and correct copy of the original and First Amended Answer and Counterclaims are attached hereto as Exhibit 5.

5. The Fourth through Ninth Counterclaims for Relief in the First Amended Answer and Counterclaims allege, among other things, that Opposer’s issuance of a press release stating that the NAPSTER “name” is “synonymous with the most well-known violation of intellectual property rights” constituted unfair competition, trade libel, defamation, commercial disparagement, breach of contract, and intentional interference with prospective contractual relations. Although the action in the District Court is currently stayed pending the Patent Office’s re-examination of the patents asserted by Petitioner in the District Court suit, the action remains pending before the District Court.

6. Petitioner filed with the District Court on February 11, 2005 a motion to dismiss that puts at issue, in largely identical language, matters asserted in the Opposition. A true and correct copy of the motion to dismiss is attached hereto as Exhibit 6. Thus, Petitioner’s motion to dismiss recites (at pages 1 to 2) the same allegations Petitioner makes in paragraph 3 of the Petition for Cancellation. Furthermore, Petitioner’s motion to dismiss (at pages 7 to 8) presents to the District Court the same assignment-in-gross arguments that are alleged in paragraphs 4 and

5 of the Opposition. The District Court has not yet ruled on Petitioner's motion to dismiss in those proceedings.

I declare under penalty of perjury under the laws of the United States of America that the foregoing is true and correct.

Executed this 6th day of June, 2005, at Los Angeles, California.

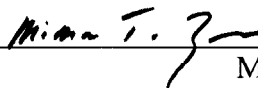

---

Michael T. Zeller

# **EXHIBIT 1**

**IN THE UNITED STATES PATENT AND TRADEMARK OFFICE  
BEFORE THE TRADEMARK TRIAL AND APPEAL BOARD**

In the Matter of:

Trademark Registration No. 2575170  
Registration Date: June 4, 2002  
For the Mark: NAPSTER

Trademark Registration No. 2841431  
Registration Date: May 11, 2004  
For the Mark: NAPSTER

Trademark Registration No. 2843786  
Registration Date: May 18, 2004  
For the Mark: NAPSTER

Trademark Registration No. 2843405  
Registration Date: May 18, 2004  
For the Mark: NAPSTER & Design

SightSound Technologies, Inc.,

*Petitioner,*

v.

Napster, LLC,

*Respondent.*

:  
:  
:  
:  
:  
:  
:  
:  
:  
:  
:

Cancellation No. \_\_\_\_\_

Commissioner of Trademarks  
P.O. Box 1451  
Arlington, Virginia 22313-1451

**PETITION FOR CANCELLATION**

SightSound Technologies, Inc., a corporation organized under the laws of the State of Delaware, having a place of business at 311 South Craig Street, Suite 205, Pittsburgh, PA 15213 (“Petitioner”), believes that it is or will be damaged by Registration Nos. 2575170, 2841431, 2843786, and 2843405, and hereby petitions to cancel the same, with knowledge concerning its own actions and on information and belief concerning all other matters.

The name and address of the current owner of Registration Nos. 2575170, 2841431, 2843786, and 2843405 is Napster, LLC, a limited liability company organized under the laws of the State of Delaware, with an address at 455 El Camino Real, Santa Clara, California 95050 (hereinafter referred to as “Respondent”).

As grounds for this Petition, it is alleged that:

1. Respondent is the owner of record of the marks listed in Registration Nos. 2575170, 2841431, 2843786, and 2843405 (the “Napster Marks”). Respondent acquired the Napster Marks through assignments, from Napster, Inc. (the original Applicant) to Roxio, Inc. (the parent of Respondent) and then from Roxio, Inc. to Respondent.

2. In a currently-pending federal court lawsuit between Petitioner and Respondent, the Respondent filed counterclaims against Petitioner asserting causes of action for, *inter alia*, trade libel, defamation, and commercial disparagement, allegedly arising from Petitioner’s reference to the name Napster. More particularly, Respondent asserts that the following statement is false: “Napster, whose name had been synonymous with the most well-known violation of intellectual property rights . . . .”

3. Napster, Inc. (the original Applicant) was embroiled in a highly publicized battle with the music industry arising from its operation of an Internet-based “service” that facilitated rampant music piracy. Nearly twenty record companies sued Napster, Inc. for contributory and vicarious copyright infringement and related causes of action, and this action was soon joined by a class of music publishers. The court found a likelihood of success on the merits of the copyright infringement claim and issued a preliminary injunction against Napster, Inc., and stated in its opinion that Napster “*contributed to illegal copying on a scale that is without precedent...*” *A&M Records, Inc. v. Napster, Inc.*, 114 F. Supp. 2d 896, 927 (N.D. Cal. 2000).

(emphasis added). In upholding the injunction (with modification) against Napster, Inc., the Ninth Circuit confirmed the rampant infringement that Napster, Inc. was engaged in:

*Napster*, by its conduct, ***knowingly encourages and assists the infringement of plaintiffs' copyrights.***

The district court . . . properly found that *Napster materially contributes to direct infringement.*

*Napster's failure to police* the system's "premises," combined with a showing that *Napster financially benefits from the continuing availability of infringing files* on its system, leads to the imposition of *vicarious liability.*

*A&M Records, Inc. v. Napster, Inc.*, 239 F.3d 1004, 1020, 1022, 1024 (9th Cir. 2001) (emphasis added). Thus, two federal courts have stated unequivocally that Napster, Inc. was an infringer of intellectual property rights (namely, copyrights).

4. In asserting that the Napster name (and, hence, each of the Napster Marks) was not associated with violation of intellectual property rights, Respondent has rejected the goodwill associated with the prior user, Napster, Inc., including the reputation that Napster, Inc. earned for facilitating copyright infringement on an unprecedented scale. As such, Respondent has admitted that it acquired the Napster Marks without the goodwill associated with the business.

5. Trademarks cannot be validly assigned without the goodwill of the business. A sale of a trademark divorced from its goodwill is an "assignment in gross," which operates to pass no rights to the purported assignee. Thus, the Napster Marks were not validly transferred from Napster, Inc. to the Respondent (or to its parent, Roxio, Inc.). As the Napster Marks are no longer used by the assignor, Napster, Inc., they have been abandoned. Accordingly, Registration Nos. 2575170, 2841431, 2843786, and 2843405 are subject to cancellation.



6. Petitioner is being injured by the continued presence on the Principal Register of Registration Nos. 2575170, 2841431, 2843786, and 2843405 because, *inter alia*, Petitioner's fair use rights to refer to the Napster name are being adversely affected by Respondent's continued registration of the Napster name as reflected in the registered Napster Marks.

7. Furthermore, the intent to use applications underlying Registration Nos. 2841431, 2843786, and 2843405 were improperly transferred in violation of 15 U.S.C. §1060. No application to register a mark under Section 1(b) of the Lanham Act, 15 U.S.C. §1051(b), shall be assignable prior to the filing of an amendment under Section 1(c), 15 U.S.C. §1051(c), to bring the application into conformity with Section 1(a), 15 U.S.C. §1051(a), or the filing of the verified statement of use under Section 1(d), 15 U.S.C. §1051(d), except for an assignment to a successor to the business of the applicant, or portion thereof, to which the mark pertains, if that business is ongoing and existing.

8. The applications underlying Registration Nos. 2841431, 2843786, and 2843405 were filed by Napster, Inc. based upon an intent to use the marks under Section 1(b) of the Lanham Act. These applications were still pending and no amendment to allege use (or statement of use) had been filed when they were transferred by the original owner, Napster, Inc., to Roxio, Inc. (Napster, LLC's parent) on November 27, 2002. To the extent that the business of Napster, Inc. was ongoing and existing at the time of the assignment, Roxio, Inc. was not a successor to the business of the original applicant, Napster, Inc. Accordingly, the applications underlying Registration Nos. 2841431, 2843786, and 2843405 were void as of the date of attempted assignment from Napster, Inc. to Roxio, Inc., and Registration Nos. 2841431, 2843786, and 2843405 are subject to cancellation.

9. These applications were again improperly transferred when, on June 13, 2003, Roxio, Inc. transferred them to its subsidiary, Napster, LLC. On that date, the applications were still pending and no amendment to allege use (or statement of use) had been filed. Accordingly, Registration Nos. 2841431, 2843786, and 2843405 are subject to cancellation.

10. Finally, the assignment of Registration Nos. 2575170, 2841431, 2843786, and 2843405 was invalid under 15 U.S.C. §1060 as there has been a substantial change in the services marketed and/or rendered under the Napster Marks, and, accordingly, there was no transfer of the goodwill to which the marks pertained. Where a transferred mark is to be used on a new and different product or service, any goodwill that the mark itself might represent cannot legally be assigned. Respondent's services under the Napster Marks are so different from the old services that the goodwill was not legally assigned, and to allow continued use and registration of the marks would work a deception upon the public. Whether the new service is better or worse than the original is wholly immaterial; the substitution of one service for a different one worked a forfeiture on whatever trademark rights Respondent attempted to acquire.

WHEREFORE, Petitioner prays this Petition for Cancellation be sustained in favor of Petitioner and that Registration Nos. 2575170, 2841431, 2843786, and 2843405 be canceled.

Please address all future communications regarding this cancellation to:

William K. Wells  
KENYON & KENYON  
1500 K Street, N.W., Suite 700  
Washington, DC 20005  
Tel.: (202) 220-4200  
Fax: (202) 220-4201

Please charge the filing fees of \$4,200.00, and any other fees associated with this proceeding to Deposit Account 11-0600.

Respectfully submitted,

s/ William K. Wells  
William K. Wells  
Brian S. Mudge  
Susan A. Smith  
KENYON & KENYON  
1500 K Street, N.W., Suite 700  
Washington, DC 20005  
Tel.: (202) 220-4200  
Fax: (202) 220-4201

*Counsel for Petitioner SightSound Technologies, Inc.*

**EXHIBIT 2**

**IN THE UNITED STATES PATENT AND TRADEMARK OFFICE  
BEFORE THE TRADEMARK TRIAL AND APPEAL BOARD**

In the Matter of:

Trademark Reg. No. 2575170  
Registration Date: June 4, 2002  
For the Mark: NAPSTER

Trademark Reg. No. 2841431  
Registration Date: May 11, 2004  
For the Mark: NAPSTER

Trademark Reg. No. 2843786  
Registration Date: May 18, 2004  
For the Mark: NAPSTER

Trademark Reg. No. 2843405  
Registration Date: May 18, 2004  
For the Mark: NAPSTER & Design

Cancellation No. 92044347

**RESPONDENT AND REGISTRANT**  
**NAPSTER, LLC'S PETITION FOR**  
**STAY**

---

SIGHTSOUND TECHNOLOGIES, INC.,

*Petitioner,*

v.

NAPSTER, LLC,

*Respondent.*

---

Commissioner of Trademarks  
P.O. Box 1451  
Arlington, Virginia 22313-1451

Respondent Napster, LLC (“Respondent” or “Registrant”), by its counsel, respectfully moves the Board to stay the instant proceedings pending the resolution of issues raised by Petitioner SightSound Technologies, Inc. (“Petitioner”) in its Petition for Cancellation that are currently before the United States Bankruptcy Court for the District of Delaware and the United States District Court for the Western District of Pennsylvania.

In support of its Motion, Respondent states as follows. In these proceedings, Petitioner seeks cancellation of four NAPSTER registrations, namely, Registration Nos. 2575170, 2841431, 2843786 and 2843405 (collectively, the “NAPSTER Registrations”). There are pending civil actions that may bear on the issues before the Board and therefore warrant the entry of a stay of these cancellation proceedings until the resolution of the relevant issues by the courts.

First, on June 3, 2002, Napster, Inc. and its subsidiaries (collectively, “Napster, Inc.”) filed voluntary petitions for relief under Chapter 11 of Title 11 of the United States Code in the Bankruptcy Court of the District of Delaware (the “Bankruptcy Court”).<sup>1</sup> After several months of collaborative efforts by the Bankruptcy Court, the appointed Bankruptcy Trustee, and the Official Committee of Unsecured Creditors, an Asset Purchase Agreement was entered into between Napster, Inc. and Roxio, Inc. (“Roxio”), which is Respondent’s parent. The Asset Purchase Agreement provided for Roxio’s acquisition of substantially all of Napster, Inc.’s tangible and intangible assets, including the marks, good will and rights underlying the NAPSTER Registrations (whether as an issued registration or as then-pending Intent to Use

---

<sup>1</sup> The facts stated herein are supported by and set forth in greater detail in the Motion to Reopen Chapter 11 Case and Enforce Sale Order and its accompanying exhibits, attached as Exhibit 1 to the Zeller Declaration (“Zeller Decl.”) submitted herewith.

applications). On November 27, 2002, after notice and a lengthy hearing at which multiple parties appeared, the Bankruptcy Court entered a Sale Order approving the Asset Purchase Agreement.

The Petition for Cancellation is specifically predicated on the alleged invalidity of the assignment of the NAPSTER Registrations that had been accomplished in the Bankruptcy Court, pursuant to the Bankruptcy Court's Sale Order on November 27, 2002. See Petition, ¶¶ 5, 7-8. Indeed, eliminating any question that Petitioner is attacking the Bankruptcy Court's Sale Order in these proceedings, the Petition for Cancellation identifies the allegedly unlawful transfer of the challenged ITU applications as having occurred "when they were transferred by the original owner, Napster, Inc., to Roxio, Inc. (Napster, LLC's parent) *on November 27, 2002*"--the date of the Bankruptcy Court's Sale Order approving their transfer pursuant to the Asset Purchase Agreement. Petition, ¶ 8 (emphasis added).

Because Petitioner has collaterally attacked the validity of the Bankruptcy Court's Sale Order and the Asset Purchase Agreement that it approved, Respondent and Roxio filed a Motion to Reopen Chapter 11 Case and Enforce Sale Order (the "Motion") on May 20, 2005. (Zeller Decl., Exh. 1.) The Motion was served on Petitioner herein on May 20, 2005. (Id., ¶ 2.) Among other things, the Motion seeks to reopen the Bankruptcy Court case and seeks an Order by the Bankruptcy Court enforcing the terms of the Sale Order, including with respect to the NAPSTER Registrations at issue in the Petition for Cancellation. (Zeller Decl., Exh. 1, 14-19.) As a result, the validity of the assignment that Petitioner challenges in these proceedings is at issue in the Motion before the Bankruptcy Court. (Id.)

Second, issues raised by the Petition for Cancellation also are the subject of another pending civil action between the parties. On January 25, 2005, Petitioner sued Respondent and Roxio in the United States District Court for the Western District of Pennsylvania (the “District Court”) in an action for ostensible patent infringement entitled *SightSound Technologies, Inc. v. Roxio, Inc. and Napster, L.L.C.*, Case No. 04-1549. (Zeller Decl., Exh. 2.) Respondent and Roxio filed an Answer and Counterclaims, as well as a First Amended Answer and Counterclaims. (Id., Exh. 3.) The Fourth through Ninth Counterclaims for Relief allege, among other things, that Petitioner’s issuance of a press release stating that the Napster “name” is “synonymous with the most well-known violation of intellectual property rights” constituted unfair competition, trade libel, defamation, commercial disparagement, breach of contract and intentional interference with prospective contractual relations. (Id.) Although the action in the District Court is currently stayed pending the Patent Office’s re-examination of the patents asserted by Petitioner in the District Court suit, the action remains pending before the District Court. (Zeller Decl., ¶ 4.)

The Petition for Cancellation reveals that it overlaps with, and duplicates, issues that are pending before the District Court. The Petition for Cancellation acknowledges that Respondent’s Counterclaims in the District Court “allegedly aris[e] from Petitioner’s reference to the name Napster” and relies on Respondent’s Counterclaims filed in the District Court as a basis for cancellation here. Petition for Cancellation, ¶¶ 2, 4. Furthermore, Petitioner filed with the District Court on February 11, 2005 a motion to dismiss that puts at issue, in largely identical language, matters asserted in the Petition for Cancellation. Thus, Petitioner’s motion to dismiss in the District Court recites the same allegations Petitioner makes in paragraph 3 of the Petition



for Cancellation. (Zeller Decl., Exh. 4, at 1-2.) Furthermore, Petitioner's motion to dismiss presents to the District Court the same assignment-in-gross arguments that are alleged in paragraphs 4 and 5 of the Petition for Cancellation. (Zeller Decl., Exh. 4, at 7-8.)<sup>2</sup>

Because the issues currently before the Bankruptcy Court and the District Court may have an effect on issues raised in the Petition for Cancellation, the instant proceedings should be stayed pending the courts' determinations. The Board's usual practice of staying its proceedings pending the outcome of a court action that may have a bearing on the issues before the Board, as is the situation here, is codified at 37 C.F.R. § 2.117(a):

“Whenever it shall come to the attention of the Trademark Trial and Appeal Board that a party or parties to a pending case are engaged in a civil action or another Board proceeding which may have a bearing on the case, proceedings before the Board may be suspended until termination of the civil action or other Board proceeding.”

See Trademark Trial and Appeal Board Manual of Procedure § 510.02(a) (“[o]rdinarily, the Board will suspend proceedings in the case before it if the final determination of the other proceeding will have a bearing on the issues before the Board.”). See also The Other Telephone Co. v. Connecticut Nat'l Telephone Co., 181 U.S.P.Q. 779, 781-82 (Comm'r of Patents 1974); Townley Clothes, Inc. v. Goldring, Inc., 100 U.S.P.Q. 57, 58 (Comm'r of Patents 1953) (“it is deemed the sounder practice to suspend the [Trademark] Office proceedings pending termination of the Court action.”).

The most logical and efficient course of action is for the Board to suspend these proceedings until the Bankruptcy Court and the District Court resolve the issues that Petitioner

---

<sup>2</sup> The District Court has not yet ruled on Petitioner's motion to dismiss in those proceedings. (Zeller Decl., ¶ 5.)

also asserts here. Respondent respectfully requests that the Board grant its motion and stay the instant cancellation proceedings pending the completion of the relevant proceedings before the Bankruptcy Court and before the District Court.

Respectfully submitted,

Dated: May 24, 2005

By: Michael T. Zeller

QUINN EMANUEL URQUHART  
OLIVER & HEDGES, LLP  
Michael T. Zeller  
Michael E. Williams  
865 South Figueroa Street, 10th Floor  
Los Angeles, California 90017  
Telephone: (213) 443-3000  
Facsimile: (213) 443-3100

*Attorneys for Respondent  
Napster, LLC*

Proof of Service

I hereby certify that a true and complete copy of the foregoing Respondent and Registrant Napster, LLC's Petition for Stay has been served on William K. Wells by mailing said copy on May 24, 2005, via First Class Mail, postage prepaid to:

William K. Wells  
Brian S. Mudge  
Susan A. Smith  
KENYON & KENYON  
1500 K Street, N.W., Suite 700  
Washington, DC 20005  
Tel.: (202) 220-4200  
Fax: (202) 220-4201

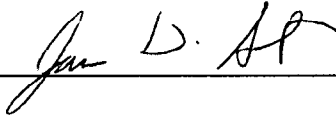

---

## **EXHIBIT 3**

**IN THE UNITED STATES PATENT AND TRADEMARK OFFICE  
BEFORE THE TRADEMARK TRIAL AND APPEAL BOARD**

In the Matter of:

Trademark Reg. No. 2575170  
Registration Date: June 4, 2002  
For the Mark: NAPSTER

Trademark Reg. No. 2841431  
Registration Date: May 11, 2004  
For the Mark: NAPSTER

Trademark Reg. No. 2843786  
Registration Date: May 18, 2004  
For the Mark: NAPSTER

Trademark Reg. No. 2843405  
Registration Date: May 18, 2004  
For the Mark: NAPSTER & Design

Cancellation No. 92044347

**DECLARATION OF MICHAEL T.  
ZELLER IN SUPPORT OF  
RESPONDENT AND REGISTRANT  
NAPSTER, LLC'S PETITION FOR  
STAY**

---

SIGHTSOUND TECHNOLOGIES, INC.,

*Petitioner,*

v.

NAPSTER, L.L.C.,

*Respondent.*

---

Commissioner of Trademarks  
P.O. Box 1451  
Arlington, Virginia 22313-1451

I, Michael T. Zeller, do hereby declare and state as follows:

1. I am a member of the State Bars of California, New York and Illinois and am counsel for Napster, LLC in these proceedings and for Napster, LLC and Roxio, Inc. in *SightSound Technologies, Inc. v. Roxio, Inc., and Napster, L.L.C.*, Civil Action No. 04-1549 (W.D. Pa.), and *In re: Enco Recovery Corp. f/k/a/ Napster, Inc.*, No. 02-11573 (PJW) (Bankr. D. Del.). I have personal knowledge of the facts stated herein and, if sworn as a witness, could and would testify competently thereto.

2. On May 20, 2005, Respondent and Roxio filed a Motion to Reopen Chapter 11 Case and Enforce Sale Order (“the Motion”) in *In re: Enco Recovery Corp. f/k/a/ Napster, Inc.* A true and correct copy of the Motion and its accompanying exhibits are attached hereto as Exhibit 1. The Motion was served on Petitioner herein on May 20, 2005. Among other things, the Motion seeks to reopen the Bankruptcy Court proceedings and seeks an Order by the Bankruptcy Court enforcing the transfer of assets, including the four NAPSTER Registrations at issue in the Petition for Cancellation. As a result, the validity of the assignment that Petitioner challenges in these proceedings is at issue in the Motion before the Bankruptcy Court.

3. On January 25, 2005, Petitioner sued Respondent and Roxio in the United States District Court for the Western District of Pennsylvania (the “District Court”) in an action for ostensible patent infringement entitled *SightSound Technologies, Inc. v. Roxio, Inc. and Napster, L.L.C.*, Case No. 04-1549. A true and correct copy of the Complaint in that action is attached hereto as Exhibit 2. Respondent and Roxio filed an Answer and Counterclaims, as well as a First Amended Answer and Counterclaims. A true and correct copy of the original and First Amended Answer and Counterclaims are attached hereto as Exhibit 3.

4. The Fourth through Ninth Counterclaims for Relief in the First Amended Answer and Counterclaims allege, among other things, that Petitioner's issuance of a press release stating that the Napster "name" is "synonymous with the most well-known violation of intellectual property rights" constituted unfair competition, trade libel, defamation, commercial disparagement, breach of contract, and intentional interference with prospective contractual relations. Although the action in the District Court is currently stayed pending the Patent Office's re-examination of the patents asserted by Petitioner in the District Court suit, the action remains pending before the District Court.

5. Petitioner filed with the District Court on February 11, 2005 a motion to dismiss that puts at issue, in largely identical language, matters asserted in the Petition for Cancellation. A true and correct copy of the motion to dismiss is attached hereto as Exhibit 4. Thus, Petitioner's motion to dismiss recites (at pages 1 to 2) the same allegations Petitioner makes in paragraph 3 of the Petition for Cancellation. Furthermore, Petitioner's motion to dismiss (at pages 7 to 8) presents to the District Court the same assignment-in-gross arguments that are alleged in paragraphs 4 and 5 of the Petition for Cancellation. The District Court has not yet ruled on Petitioner's motion to dismiss in those proceedings.

I declare under penalty of perjury under the laws of the United States of America that the foregoing is true and correct.

Executed this 24th day of May, 2005, at Los Angeles, California.

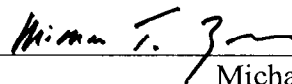

---

Michael T. Zeller

**EXHIBIT 1**



IN THE UNITED STATES BANKRUPTCY COURT  
FOR THE DISTRICT OF DELAWARE

IN RE: ENCO RECOVERY CORP.	)	Chapter 11
f/k/a NAPSTER, INC.,	)	
a Delaware corporation, et al.,	)	Jointly Administered
	)	Case No. 02-11573 (PJW)
	)	
Debtors.	)	Objection Deadline: June 6, 2005 @ 4:00 p.m.
	)	Hearing Date: June 13, 2005 @ 2:30 p.m.

---

NOTICE OF MOTION TO REOPEN CHAPTER 11  
CASE AND ENFORCE SALE ORDER

PLEASE TAKE NOTICE that on May 19, 2005, Roxio, Inc. and Napster, LLC (collectively, the "Movants") filed the attached *Motion to Reopen Chapter 11 Case and Enforce Sale Order* (the "Motion") with the United States Bankruptcy Court for the District of Delaware, 824 Market Street, 3rd Floor, Wilmington, Delaware 19801 (the "Bankruptcy Court").

PLEASE TAKE FURTHER NOTICE that a hearing on the Motion will be held before The Honorable Peter J. Walsh on **June 13, 2005 at 2:30 p.m. (Eastern Time)**.

PLEASE TAKE FURTHER NOTICE that any objections to the Motion must be in writing, filed with the Clerk of the Bankruptcy Court, 824 Market Street, 3rd Floor, Wilmington, Delaware 19801, and served upon and received by the undersigned counsel for the Movants on or before **June 6, 2005 at 4:00 p.m. (Eastern Time)**.

Date filed: 5/19/05

Docket #: 972

IN THE EVENT THAT NO OBJECTION IS FILED AND RECEIVED BY  
MOVANTS IN ACCORDANCE WITH THIS NOTICE, THE COURT MAY GRANT THE  
RELIEF REQUESTED IN THE MOTION WITHOUT FURTHER NOTICE OR HEARING.

Dated: May 16, 2005  
Wilmington, Delaware

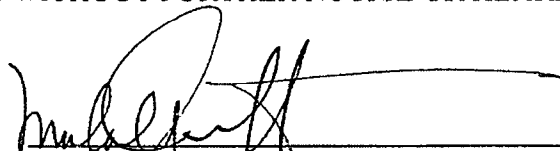

Mark D. Collins (No. 2981)  
Michael J. Merchant (No. 3854)  
RICHARDS, LAYTON & FINGER, P.A.  
One Rodney Square  
P. O. Box 551  
Wilmington, Delaware 19899  
(302) 651-7700

- and -

Michael T. Zeller (*pro hac* application pending)  
QUINN EMANUEL URQUHART OLIVER &  
HEDGES, LLP  
865 S. Figueroa Street, 10th Floor  
Los Angeles, California 90017  
Telephone: 213-443-3100  
Facsimile: 213-443-3200

- and -

Suzanne Uhland (*pro hac* application pending)  
O'MELVENY & MYERS LLP  
400 South Hope St.  
Los Angeles, California 90071  
(213) 430-6000

Attorneys for Plaintiffs  
ROXIO, INC. and NAPSTER, L.L.C.

**IN THE UNITED STATES BANKRUPTCY COURT  
FOR THE DISTRICT OF DELAWARE**

<b>IN RE: ENCO RECOVERY CORP.</b>	)	<b>Chapter 11</b>
<b>f/k/a NAPSTER, INC.,</b>	)	
<b>a Delaware corporation, et al.,</b>	)	<b>Jointly Administered</b>
	)	<b>Case No. 02-11573 (PJW)</b>
	)	
<b>Debtors.</b>	)	<b>Objection Deadline: June 6, 2005 @ 4:00 p.m.</b>
_____	)	<b>Hearing Date: June 13, 2005 @ 2:30 p.m.</b>

**MOTION TO REOPEN CHAPTER 11  
CASE AND ENFORCE SALE ORDER**

Roxio, Inc. and Napster, LLC (collectively, the “Movants”), by and through their undersigned counsel, hereby move the Court, pursuant to sections 105, 350(b) and 363 of title 11 of the United States Code (the “Bankruptcy Code”), and Rule 3020(d) of the Federal Rules of Bankruptcy Procedure (the “Bankruptcy Rules”), for the entry of an order (i) reopening the chapter 11 cases of Enco Recovery Corp. (f/k/a/ Napster, Inc.), Enco-2 Recovery Corp. (f/k/a Napster Music Company, Inc.) and Enco-3 Recovery Corp. (f/k/a Napster Mobile Company, Inc.) (collectively, the “Debtors”), and (ii) enforcing the Court’s Order approving the sale of the Debtors’ assets to Roxio, Inc. (the “Motion”). In support of the Motion, the Movants respectfully represent as follows:

**I. JURISDICTION AND VENUE**

1. This Court has jurisdiction over this proceeding pursuant to 28 U.S.C. §§ 157 and 1334(b).
2. This Court also has retained jurisdiction to grant the relief requested herein pursuant to Paragraph 22 of its Order Under 11 U.S.C. §§ 105(a), 363, 365 and 1146(c), and Fed. R. Bankr. P. 2002, 6004, 6006, and 9014 (A) Approving Asset Purchase Agreement;

(B) Authorizing the Sale of Substantially All of Debtors' Assets; (C) Authorizing Assumption and Assignment of Certain Executory Contract; and (D) Granting Other Related Relief (the "Sale Order") [Docket No. 423].<sup>1</sup>

3. Venue is proper in this Court pursuant to 28 U.S.C. § 1409(a) because this Motion concerns a matter that arises in, and is related to, the Debtors' chapter 11 cases.

## II. BACKGROUND

4. On June 3, 2002, the Debtors filed voluntary petitions for relief under chapter 11 of the Bankruptcy Code in this Court. The chapter 11 cases were procedurally consolidated for administrative purposes. Prior to filing their bankruptcy petitions, the Debtors provided an online service whereby users could download and share music and other content via the Internet. *See A&M Records, Inc. v. Napster, Inc.*, 114 F. Supp. 2d 896, 901-902 (N.D. Cal. 2000).

5. Following several eventful and contentious months during which, among other things, the Court rejected a proposed sale of the Debtors' assets to Bertelsmann AG and appointed Hobart G. Truesdell as Chapter 11 trustee (the "Trustee"), the Court approved the sale of substantially all of the Debtors' assets to Roxio, Inc. ("Roxio"). The process leading to the sale involved substantial collaborative efforts by this Court, the Trustee and the Official

---

<sup>1</sup> A true and correct copy of the Sale Order is attached hereto as Exhibit A. Paragraph 22 of the Sale Order states:

This Court retains jurisdiction to enforce and implement the terms and provisions of the Asset Purchase Agreement, all amendments thereto, any waivers and consents thereunder, and of each of the agreements executed in connection therewith in all respects, including, but not limited to, retaining jurisdiction to (a) compel delivery of the Assets to the Buyer, (b) resolve any disputes arising under or related to the Asset Purchase Agreement, except as otherwise provided therein, (c) interpret, implement, and enforce the provisions of this Sale Order, and (d) protect the Buyer against (i) any of the Excluded Liabilities or (ii) any Interests in the Debtors or the Assets, of any kind or nature whatsoever, attaching to the proceeds of the Sale.

Committee of Unsecured Creditors to maximize the value of the Debtors' estate and to resolve their bankruptcy cases. These efforts included extensively marketing the Debtors' assets and soliciting bids from interested parties for those assets.

**A. Roxio, Inc. Acquires Substantially All of the Debtor's Assets, Including Their Marks and Associated Goodwill, Pursuant to This Court's Sale Order.**

6. One bidder for the Debtors' assets was Roxio, which provided debtor-in-possession financing to the Debtors so that they could continue business operations during the pendency of the bankruptcy proceedings (the "DIP Financing"). On November 27, 2002, after notice and a lengthy hearing at which multiple parties appeared, Roxio's bid for the Debtors' assets was deemed the highest and best offer, and the Court entered the Sale Order authorizing and approving that certain Asset Purchase Agreement dated as of November 15, 2002 between Napster, Inc., Napster Music Company, Inc., Napster Mobile Company, Inc. and Roxio, Inc. (the "Asset Purchase Agreement" or "APA").<sup>2</sup>

7. Pursuant to the Asset Purchase Agreement, Roxio acquired all of the Debtors' assets except for certain excluded assets (the "Napster Assets").<sup>3</sup> See Sale Order, ¶¶ 4, 9; see also APA, §§ 2.1, 2.2, 3.3. In exchange, Roxio paid substantial consideration: approximately \$5 million in cash, a warrant for 100,000 common shares of Roxio (the "Warrant") and forgiveness of approximately \$200,000 due under the DIP Financing provided by Roxio. See APA, § 2.6.

8. The Napster Assets acquired by Roxio consisted of the tangible and intangible property that formed the core of the Debtors' on-line services and related technology.

---

<sup>2</sup> A true and correct copy of the Asset Purchase Agreement is attached hereto as Exhibit B.

<sup>3</sup> The amounts paid by Roxio were ultimately used to fund the Debtors' administrative expenses and to provide a distribution to creditors. Moreover, through the Warrant (which was exercised by the Trustee and generated additional cash proceeds of approximately \$500,000), creditors were provided with a valuable interest in the going concern business that Roxio continued to operate following the acquisition of the Napster Assets.

This included:

- “[A]ll of Sellers’ right, title and interest in, to and under the assets, properties, contract rights and Intended Business<sup>4</sup>] as of the commencement of the Bankruptcy Case, of every kind and description, wherever located, real, personal or mixed, tangible or intangible, owned, held or used by the Sellers in the conduct of their Intended Business as the same shall exist on the Closing Date, other than the Excluded Assets, but including, without limitation, (a) all assets shown on Schedule B of the Schedule of Assets and Liabilities filed by each of the Sellers and Schedule 2.1 hereto and (b) all right, title and interest of Sellers in, to and under the following (collectively, the “Purchased Assets”).” APA § 2.1.
- “[A]ll of Sellers’ rights, title and interest in, to and under **all Intellectual Property Rights** owned, licensed or used by the Sellers (**including the goodwill of the Intended Business in which any of the marks are used**), including the items listed in Schedule 2.1(b).” APA, § 2.1(b) (emphasis added).<sup>5</sup>
- “[A]ll goodwill associated with the **Purchased Assets, together with the right to represent to third parties that Buyer is the successor to the Intended Business operated by the Sellers.**” APA § 2.1(f) (emphasis added).

---

<sup>4</sup> The term “Intended Business” is defined in the Asset Purchase Agreement as “the Sellers’ intended business of operating a legal secure online subscription service for the distribution and sharing of music and other content.” APA § 1.1(a).

<sup>5</sup> The term “Intellectual Property Rights” is defined as

all patents, patent applications and other patent rights (including any divisions, continuations, continuations-in-part, requests for continued examinations, substitutions, or reissues and reexaminations thereof, whether or not any such applications are modified, withdrawn or resubmitted), trademarks, trade dress, service marks, corporate names, domain names, trade names, brand names, service marks, service names, mask works, assumed names, logos, inventions, trade secrets, designs, technology, know-how, processes, procedures, techniques, methods, inventions, proprietary data, formulae, research and development data, computer software programs and other intangible property, copyrights (**including all variants thereof and any registration or applications for registration** of any of the foregoing and non-registered copyrights), including all files, manuals, documentation and source and object codes related to any of the foregoing, or any other similar type of proprietary intellectual property right (whether or not patentable or subject to copyright, mask work or trade secret protection) and the Assigned Intellectual Property, in each case which is owned, licensed or used by any Seller.

APA, § 1.1(a) (emphasis added).

- “[A]ll Books and Records, files and papers, whether in hard copy or computer format related to the Purchased Assets, including, without limitation, engineering information, sales and promotional literature, manuals and data, sales and purchase correspondence, lists of present and former suppliers, lists of present and former customers, personnel and employment records, and any information relating to Tax imposed on the Purchased Assets.” APA, § 2.1(d).
- “[A]ny non-disclosure agreements entered into between any of the Sellers and any current or former employees or consultants or any other third parties to protect confidential information of Sellers.” APA, §§ 2.1(g).
- “[A]ny Intellectual Property Rights assignment agreements, including, without limitation, any agreements executed by employees or agents acknowledging the proprietary interest of Sellers in any Intellectual Property Rights.” APA, § 2.1(h).
- The Debtors’ subscriber lists, including (i) “[a] list of subscribers to the Napster beta service,” (ii) “[a] list of subscribers to the Napster newsletter,” (iii) “[a] list of subscribers to the Napster ‘Featured Music’ mailing list,” (iv) “[a] list of subscribers to the ‘Political Action Network’ mailing list,” (v) “[a] list of people who have emailed Napster’s customer service department” and (vi) “[a]ll other information Napster has collected and possesses regarding its users.” APA, Schedule 3.6(a).
- “[A]ll computer software programs and data used in connection with the Purchased Assets.” APA, § 2.1(e).

9. Among the trademarks, trademark registrations and pending applications

for registration which were transferred to Roxio under the terms of the Asset Purchase

Agreement were each of the following:

- (i) United States Trademark Registration No. 2575170 for the mark NAPSTER, registered on the Principal Register of the United States Trademark Office on June 4, 2002 (the “NAPSTER Registration”) (APA, § 2.1(b), Schedule 3.6(a));<sup>6</sup> and
- (ii) three then-pending Intent-to-Use applications that Napster, Inc. had filed with the United States Trademark Office (the “NAPSTER ITU Applications”) and

---

<sup>6</sup> A true and correct copy of the NAPSTER Registration is attached hereto as Exhibit C.

that subsequently ripened into United States Trademark Registration Nos. 2841431, 2843786 and 2843405 (APA, § 2.1(b), Schedule 3.6(a)).<sup>7</sup>

10. In the Sale Order, the Court expressly approved the Asset Purchase Agreement and the transfer of the Napster Assets to Roxio. Sale Order ¶ 4 (“The Asset Purchase Agreement, and all of the terms and conditions thereof, is hereby approved.”). In doing so, the Court specifically found and ordered:

- “Pursuant to 11 U.S.C. §§ 105(a) and 363(f), the Assets shall be transferred to the Buyer” and “[t]he transfer of the Assets to the Buyer pursuant to the Asset Purchase Agreement constitutes a **legal, valid, and effective transfer of the Assets, and shall vest the Buyer with all right, title, and interest of the Debtors in and to the Assets . . .**” Sale Order, ¶¶ 7, 9 (emphasis added).
- “The terms and provisions of the Asset Purchase Agreement and this Sale Order **shall be binding** in all respects upon, and shall inure to the benefit of, the Debtors, their estates, and their creditors, the Buyer, and their respective affiliates, successors and assigns, and **any affected third parties . . .**” Sale Order, ¶ 26 (emphasis added).
- “Each and every federal, state, and local governmental agency or department, registrar of internet domain names and any other person or entity is hereby directed to accept any and all documents and instruments necessary and appropriate to consummate the transactions contemplated by the Asset Purchase Agreement.” Sale Order, ¶ 16.

11. Following the sale, the Debtors changed their corporate names because they were among the Intellectual Property Rights acquired by Roxio. See APA, § 5.7. Roxio subsequently assigned the Napster Assets to Napster, LLC, which currently offers music and other content for downloading on the Internet. The marks that are the subject of the NAPSTER Registration, and the then-pending NAPSTER ITU Applications, are being used, and at all relevant times have been used, in connection with the sale, advertisement, and marketing of

---

<sup>7</sup> True and correct copies of each of the foregoing registrations that resulted from the NAPSTER ITU Applications are attached hereto as Exhibits D, E and F.



music and other content offered for downloading over the Internet.

**B. SightSound Technologies, Inc. Attacks the Sale Order and Alleges that the Debtors' Marks And Business Were Not Actually Transferred to Roxio.**

12. More than two years after the Court approved the Asset Purchase Agreement and entered the Sale Order – and despite the explicit findings and rulings it made therein – SightSound Technologies, Inc. (“SightSound”) has recently launched an attack on the Sale Order and the validity of the sale and transfer of the Napster Assets to Roxio.

13. Specifically, on or about March 22, 2005, SightSound filed a petition (the “Petition”) with the United States Trademark Trial and Appeal Board (“TTAB”) seeking the cancellation of the NAPSTER Registration and the registrations upon which the NAPSTER ITU Applications were based that were included in the Napster Assets acquired by Roxio from the Debtors pursuant to the Sale Order and Asset Purchase Agreement.<sup>8</sup>

14. In the Petition, SightSound makes two attacks that seek to undermine, and indeed nullify, the validity of the transfer of the Napster Assets to Roxio pursuant to the Sale Order and Asset Purchase Agreement. Both of these challenges are based on the premise that the Court’s findings and rulings in the Sale Order, as well as its approval of the Asset Purchase Agreement (and the sale of the Napster Assets), are all without legal effect with respect to the NAPSTER Registration and NAPSTER ITU Applications – except apparently to result in their cancellation.<sup>9</sup>

15. First, SightSound asserts, quite remarkably, that the transfer of the NAPSTER Registration and NAPSTER ITU Applications was invalid because it was

---

<sup>8</sup> A true and correct copy of the Petition is attached hereto as Exhibit G.

<sup>9</sup> SightSound does not assert an interest in the NAPSTER Registration or NAPSTER ITU Applications, nor does it claim any independent right in the registrations.

purportedly made without their accompanying goodwill and therefore constituted an “assignment in gross.” See Petition, ¶¶ 5, 10. The Sale Order and Asset Purchase Agreement, however, **expressly provide that Roxio did acquire such goodwill along with the other Napster Assets.**<sup>10</sup>

16. Second, SightSound alleges that Roxio is “not a successor to the business of” Napster, Inc. and therefore the NAPSTER ITU Applications are void – notwithstanding the fact that the **Sale Order and Asset Purchase Agreement expressly provide that Roxio acquired the Debtors’ business and the right to represent that it is the successor to the Debtors’ business.** Petition, ¶ 8.

17. In making these allegations and filing the Petition, SightSound seeks to undermine several key terms of the Sale Order<sup>11</sup> and Asset Purchase Agreement, including:

- The provision of the Sale Order which found that the transfer of the Napster Assets under the Asset Purchase Agreement (including the NAPSTER Registration and NAPSTER ITU Applications and associated goodwill) “constitutes a legal, valid, and effective transfer of the Assets, and shall vest the Buyer with all right, title, and interest of the Debtors in and to the Assets.” See Sale Order, ¶ 9.
- The provisions of the Sale Order that approved the Asset Purchase Agreement and all of its terms and conditions, and authorized the sale of the Napster Assets to Roxio, which included the NAPSTER Registration

---

<sup>10</sup> Goodwill is “the expectancy of continued patronage” for a business and is a label for the “imponderable qualities that attract customers to the business.” *Newark Morning Ledger Co. v. United States*, 507 U.S. 546, 555-56 (1993) (internal quotation marks omitted). *See also In re Brown*, 242 N.Y. 1, 6 (1926) (“Men will pay for any privilege that gives a reasonable expectancy of preference in the race of competition. ... Such expectancy may come from succession in place or name or otherwise to a business which has won the favor of its customers. It is then known as good will.”). As described below, not only did the Sale Order and Asset Purchase Agreement state that the relevant goodwill was being transferred, but the nature of the transaction – which assigned customer lists, technology and an array of tangible and intangible assets – makes clear that such goodwill was in fact transferred as part of the Sale Order and the Asset Purchase Agreement.

<sup>11</sup> SightSound’s identification of the allegedly unlawful transfer of the NAPSTER ITU Applications as having occurred on November 27, 2002 – the date of the Sale Order – makes clear that it is directly challenging the effectiveness of the Sale Order. See Petition, ¶ 8.

and NAPSTER ITU Applications and associated goodwill. See Sale Order, ¶¶ 4-7, 28.

- The provision of the Sale Order which mandated that the terms of the Sale Order and Asset Purchase Agreement are “binding in all respects upon . . . any affected third parties.” See Sale Order, ¶ 26.
- The provisions of the Asset Purchase Agreement pursuant to which the NAPSTER Registration and NAPSTER ITU Applications and associated goodwill were transferred to Roxio. See APA, § 2.1(b), Schedule 3.6(a).
- The provision of the Asset Purchase Agreement pursuant to which all goodwill associated with the Napster Assets “together with the right to represent to third parties that [Roxio] is the successor to the Intended Business operated by” the Debtors were transferred to Roxio. APA, § 2.1(f).
- The provision of the Asset Purchase Agreement that represented “[t]he consummation of the transactions contemplated by this Agreement will not alter, impair or extinguish any Intellectual Property Rights owned, licensed or used by Sellers.” APA, § 3.6(f).

### III. ARGUMENT

18. As explained below, the Court should (i) reopen the Debtors’ bankruptcy case and enforce the Sale Order and Asset Purchase Agreement and (ii) prohibit SightSound from further attacking and seeking to undo the Sale Order, Asset Purchase Agreement and the transfer of the Napster Assets to Roxio, including without limitation the NAPSTER Registration and the NAPSTER ITU Applications together with their associated goodwill.

#### A. **The Court Should Reopen the Debtors’ Bankruptcy Cases To Enforce the Sale Order and Asset Purchase Agreement.**

19. Bankruptcy Code Section 350(b) provides that “[a] case may be reopened in the court in which such case was closed to administer assets, to accord relief to the debtor, or for other cause.” 11 U.S.C. § 350(b). The Movants submit that sufficient cause exists to reopen the Debtors’ bankruptcy case and enforce the Court’s Sale Order.

20. “A proceeding under section 363 is an *in rem* proceeding. It transfers property rights, and property rights are rights good against the world, not just against parties to a judgment or persons with notice of the proceeding.” *Gekas v. Pipin (In re Met-L-Wood Corp.)*, 861 F.2d 1012, 1017 (7<sup>th</sup> Cir. 1988); *see also e.g. Regions Bank v. J.R. Oil Co., LLC*, 387 F.3d 721, 732 (8<sup>th</sup> Cir. 2004) (“[a] bankruptcy sale under 11 U.S.C. § 363, free and clear of all liens, is a judgment that is good against the world, not merely as against parties to the proceedings.”).

21. As a result, even nonparties are barred from attacking or undermining the sale and transfer of assets to a buyer made pursuant to Bankruptcy Code Section 363 in a bankruptcy case. *See e.g. Met-L-Wood*, 861 F.2d at 817; *Regions Bank*, 387 F.3d at 732 (nonparties are barred by “the nature of rights transferred under 11 U.S.C. § 363” from attacking or challenging assets transferred and sold to buyer).

22. Here, SightSound seeks to nullify keys terms of the Sale Order and Asset Purchase Agreement, and to undermine the sale of the Napster Assets. SightSound asserts that the NAPSTER Registration and NAPSTER ITU Applications were transferred to Roxio as part of an “assignment in gross” – that is, without their associated goodwill.<sup>12</sup> It claims that the Sale Order and Asset Purchase Agreement are void in that they did not transfer the NAPSTER Registration and NAPSTER ITU Applications and associated goodwill to Roxio, and that Roxio is not a successor to the Debtors.

23. **These issues, however, have already been addressed and resolved in this Court.** The Sale Order and Asset Purchase Agreement provide that the Napster Assets acquired by Roxio specifically include the Debtors’ trademarks, trademark registrations and pending applications for registration and all of their associated goodwill. See Sale Order ¶¶ 4-7,

---

<sup>12</sup> SightSound’s attack on this Court’s power and the Sale Order is even more disconcerting considering that SightSound does not assert any interest or independent right in the registrations or the underlying marks.

28. The Asset Purchase Agreement specifically transferred all goodwill associated with the Napster Assets to Roxio “together with the right to represent to third parties that [Roxio] is the successor to the Intended Business operated by” the Debtors. APA, § 2.1(f). This Court also found and ordered that the transfer of the Napster Assets (including the NAPSTER Registration and NAPSTER ITU Applications and associated goodwill) to Roxio constituted a “legal, valid, and effective transfer” and vested Roxio “with all right, title, and interest” in and to the Napster Assets. Sale Order ¶ 9 (emphasis added).

24. The provisions of the Sale Order and Asset Purchase Agreement mean precisely what they state: that Roxio acquired the NAPSTER Registration and NAPSTER ITU Applications together with their goodwill from the Debtors, and that Roxio (and its subsequent assignees) are successors to the business operated by the Debtors. Having approved the Asset Purchase Agreement, the sale of the Napster Assets (including the NAPSTER Registration and NAPSTER ITU Applications and associated goodwill) to Roxio and entered the Sale Order – and having made specific finding and rulings in connection therewith – the Court should protect the integrity of this transaction by reopening the Debtors’ bankruptcy case and enforcing the Sale Order.

**B. The Court Should Enforce the Sale Order and Asset Purchase Agreement That Transferred the NAPSTER Registration and NAPSTER ITU Applications and Associated Goodwill to Roxio.**

**1. The Court Should Prohibit SightSound from Further Attacking or Undermining the Sale Order, Asset Purchase Agreement and the Transfer of the Napster Assets to Roxio.**

25. SightSound’s attack upon the Sale Order in TTAB plainly seeks to invalidate the Sale Order, Asset Purchase Agreement and transactions specifically approved by

this Court.<sup>13</sup> SightSound seeks to nullify and void the sale of the NAPSTER Registration and NAPSTER ITU Applications and associated goodwill to Roxio under Bankruptcy Code Section 363 by claiming, in a **separate proceeding**, that no such goodwill was transferred and that Roxio was not a successor to the Debtors' business – despite the Court's findings and rulings to the contrary in the Sale Order and the terms of the Asset Purchase Agreement.

26. It is well established that “[j]udicial sales are to be accorded a substantial measure of finality in order to protect and encourage the process of selling estate assets. If parties are to be encouraged to bid at judicial sales there must be stability in such sales and a time must come when a fair bid is accepted and the proceedings are ended.” *Musi v. Nigro (In re Homestead Industries, Inc.)*, 138 B.R. 788, 790 (Bankr. W.D. Pa. 1992) (citing *in re Webcor*, 392 F.2d 893, 898 (7<sup>th</sup> Cir. 1968)).

27. Indeed, “[i]f purchasers at judicially approved sales of property of a bankrupt estate . . . cannot rely on the deed that they receive at the sale, it will be difficult to liquidate bankrupt estates at positive prices. This insight informs the law’s treatment of efforts to undo such sales.” *In re Edwards*, 962 F.2d 641, 643 (7<sup>th</sup> Cir. 1992) (internal citations omitted).

28. SightSound, however, seeks to undermine this very process and the finality of the Sale Order. It is equally apparent that, unless prohibited by this Court, SightSound will continue to attack the Sale Order and the Asset Purchase Agreement in other tribunals, including by pursuing the cancellation of the NAPSTER Registration and the NAPSTER ITU Applications acquired by Roxio. It should not be permitted to do so.

---

<sup>13</sup> SightSound’s resort to TTAB is especially inappropriate because the matters raised by SightSound should be considered in the first instance only by this Court and may be challenged, if at all, only on proper appeal from the Sale Order or upon motion seeking to vacate the Sale Order. *See e.g. In re Chicago, Milwaukee, St. Paul and Pacific R R Co*, 6 F.3d 1184, 1194 (7<sup>th</sup> Cir. 1993) (“the reorganization court is clearly in the best position . . . to interpret the consummation order . . .”); *In re Kewanee Boiler Corp*, 270 B.R. 912, 917 (Bankr. N.D. Ill. 2002) (bankruptcy courts should interpret and enforce their orders) (citing *In re Weber*, 25 F.3d 413, 416 (7<sup>th</sup> Cir. 1994)).

29. “It is axiomatic that a court possesses the inherent authority to enforce its own orders.” *In re Continental Airlines, Inc.*, 236 B.R. 318, 325-26 (Bankr. D. Del. 1999), *aff’d*, 279 F.3d 226 (3<sup>rd</sup> Cir. 2002) (citations omitted); *see also e.g.* Fed. R. Bankr. P. 3020(d) (“[n]otwithstanding the entry of the order of confirmation, the court may issue any other order necessary to administer the estate.”). Moreover, Bankruptcy Code Section 105(a) provides that a bankruptcy court is authorized to issue any order, process or judgment necessary to carry out the provisions of the Bankruptcy Code, and “gives the bankruptcy court ‘the power and the jurisdiction to enforce its valid orders.’” *In re Marcus Hook Development Park, Inc.*, 943 F.2d 261, 266 (3<sup>rd</sup> Cir. 1991) (*quoting In re Radco Merchandising Services, Inc.*, 111 B.R. 684, 688-89 (N.D. Ill. 1990)); 11 U.S.C. § 105(a). In the exercise of this authority, courts have inherent powers to enforce compliance with and execution of their lawful orders. *See e.g. Continental Airlines*, 236 B.R. at 331 (finding creditors in contempt of plan and confirmation order and awarding debtor attorneys’ fees and costs); *In re Kennedy*, 80 B.R. 673 (Bankr. D. Del. 1987) (finding party in contempt of court order and awarding attorneys’ fees incurred in bringing motion for contempt).

30. Here, the Court should exercise its authority to enforce the terms of the Sale Order and prohibit SightSound from further attacking or seeking to undermine the Sale Order, Asset Purchase Agreement and the validity of the transfer of the NAPSTER Registration and the NAPSTER ITU Applications to Roxio. *See e.g. La Prefereida, Inc. v. Cerveceria Modelo, S.A. de CV*, 914 F.2d 900, 908 (7<sup>th</sup> Cir. 1990) (barring party from asserting rights to trademark transferred and sold under bankruptcy court sale pursuant to Bankruptcy Code Section 363 and noting that “bankruptcy sales, if they are to fulfill their role, must be final when made.”); *Edwards*, 962 F.2d at 641 (“[t]he bona fide purchaser at a bankruptcy sale gets good title”).

**2. The Validity of the Assignment is Supported By the Sale Order, the Specific Terms of the Asset Purchase Agreement and the Transfer of Substantially All of Napster, Inc.'s Assets Under the Asset Purchase Agreement.**

31. SightSound's allegations that the NAPSTER Registration and the NAPSTER ITU Applications were assigned in gross – that is, without their accompanying goodwill – are groundless. A trademark may be validly assigned if the goodwill associated with the mark is also assigned, and trademark rights may be validly assigned by a trustee in bankruptcy proceedings. *VISA, U.S.A., Inc. v. Birmingham Trust Nat'l Bank*, 696 F.2d 1371, 1375 (Fed. Cir. 1982); *see also Roman Cleanser Co., v. Nat'l Acceptance Co. of America*, 43 B.R. 940, 947 (Bankr. E.D. Mich. 1984), *aff'd*, 802 F.2d 207 (6<sup>th</sup> Cir. 1986); 15 U.S.C. § 1060. An “assignment-in-gross” only occurs when a mark is assigned without its associated goodwill. *VISA*, 696 F.2d at 1375.<sup>14</sup>

32. The Sale Order and Asset Purchase Agreement expressly provide that the NAPSTER Registration and the NAPSTER ITU Applications were assigned along with their associated goodwill, which supports the conclusion that their goodwill was in fact transferred and that the assignment was valid. *See Glamorene Products Corp. v. Procter & Gamble Co.*, 538 F.2d 894, 895 (C.C.P.A. 1976) (assignment provided mark was assigned ““together with the goodwill of the business symbolized by said trademark and in connection with which said trademark is used.””); *eMachines, Inc. v. Ready Access Memory, Inc.*, No. EDCV00-00374-VAPEEX, 2001 WL 456404, \*11 (C.D. Cal. March 5, 2001) (agreement evinced intent for “good will to pass with the assignment.”); *Main Street Outfitters, Inc. v. Federated Dep't Stores*,

---

<sup>14</sup> The basic rationale for the anti-assignment-in-gross rule lies in the nature of trademarks: because a trademark identifies the source of goods or services, the separation of a trademark from its established associations will result in consumer deception since the trademark is no longer associated with the same or similar products or services. *VISA*, 696 F.2d at 1375; *Roman Cleanser*, 43 B.R. at 947. Thus, the ultimate concern and purpose behind the rule is the protection of the public. *Money Store v. Harriscorp Finance, Inc.*, 689 F.2d 666, 676 (7<sup>th</sup> Cir. 1982), *citing Syntex Laboratories v. Norwich Pharm. Co.*, 315 F. Supp. 45 (S.D.N.Y. 1970), *aff'd*, 437 F.2d 566 (2d Cir. 1971)



*Inc.*, 730 F. Supp. 289, 290-91 (D. Minn. 1989) (agreement provided transfer of “all the good will then attached to the trademark.”); *Bambu Sales, Inc. v. Sultana Crackers, Inc.*, 683 F. Supp. 899, 905 (E.D.N.Y. 1988) (amended assignment agreement recited assignment of goodwill); *Marshak v. Green*, 505 F. Supp. 1054, 1061 (S.D.N.Y. 1981) (instrument provided for transfer of goodwill); *Redmond Products, Inc. v. ETS, Inc.*, 1998 WL 698407, \*8 (T.T.A.B. 1998) (mark assigned along with recitation of goodwill).

33. The nature of the transaction also confirms that the associated goodwill of the NAPSTER Registration and the NAPSTER ITU Applications was, in fact, assigned with them. First, substantially all of the Debtors’ assets were transferred under the Sale Order and Asset Purchase Agreement to Roxio. The Napster Assets acquired by Roxio consist of tangible and intangible property that formed the core of Napster Inc.’s Internet music services, content and related technology, including without limitation (i) all intellectual property rights (including all trademarks, federal trademark registrations, pending applications for registration relating to those marks and all good will associated with the business in which any trademarks were used), (ii) all computer software programs and data, (iii) all books and records, (iv) all claims and causes of action (with certain exceptions such as avoidance actions), (v) certain equipment and (vi) all goodwill associated with the business. See APA, § 2.1; *see also SMI Industries Canada Ltd., v. Caelter Industries, Inc.*, 586 F. Supp. 808, 822 (N.D.N.Y 1984); *see also H & J Foods, Inc. v. Reeder*, 477 F.2d 1053, 1055-56 (9<sup>th</sup> Cir. 1973) (assignment held valid where assignor gave up the right to use the mark and assignee acquired assignor’s “related tangible assets of any conceivable value.”). Indeed, the Asset Purchase Agreement expressly provides that “[t]he Purchased Assets, taken as a whole, **constitute all the properties, assets and rights related to the Intended Business.**” APA, § 3.3 (emphasis added).

34. Second, Roxio provided valuable consideration for the Napster Assets, including the NAPSTER Registration and the NAPSTER ITU Applications. As a result of the Sale Order and Asset Purchase Agreement, Roxio acquired the Napster Assets in exchange for approximately \$5.7 million. This consideration was deemed the highest and best offer by both the Trustee and the Court. The fact that Roxio paid “good and valuable” consideration for the NAPSTER Registration and the NAPSTER ITU Applications additionally supports the validity of their assignment. *See Glamorene Products Corp.*, 538 F.2d at 895 (effective assignment found where assignee paid “good and valuable” consideration).

35. Finally, neither Roxio nor the Trustee intended to deceive the public in the transfer of the NAPSTER Registration or the NAPSTER ITU Applications, and there is no evidence showing otherwise. Since the late 1990’s, the NAPSTER marks have become associated with the service of downloading of music and other content over the Internet. *See A&M Records*, 114 F. Supp. 2d at 901-902. It was this association, or “goodwill,” that Roxio intended to obtain through the Asset Purchase Agreement and later exploit in marketing its service of allowing subscribers to download and share music and other content. Because Roxio intended to utilize the “goodwill” that was already associated with the marks – as the Asset Purchase Agreement expressly stated – there was no intent to deceive or harm the public. This, too, supports the conclusion that the NAPSTER Registration and the NAPSTER ITU Applications were properly assigned. *eMachines*, 2001 WL 456404, at \*11; *Main Street Outfitters*, 730 F. Supp. at 291-92 (assignment valid because, among other reasons, assignee intended to exploit the goodwill associated with the mark).

**3. The NAPSTER ITU Applications Were Properly Assigned In Compliance With Section 10 Of The Lanham Act.**

36. SightSound additionally contends that “[t]o the extent that the business of Napster, Inc. was ongoing and existing at the time of the assignment, Roxio, Inc. was not a successor to the business” of the Debtors and therefore, the NAPSTER ITU Applications “were void as of the date of the attempted assignment from Napster, Inc. to Roxio, Inc.” – namely, at the time they were assigned under the Asset Purchase Agreement approved by this Court’s Sale Order. See Petition, ¶ 8.

37. This further attack on the Sale Order and the Asset Purchase Agreement is unfounded. Like an already issued trademark registration, a pending ITU application for a mark may be properly transferred. Pursuant to Section 10 of the Lanham Act, the assignment of an ITU application prior to the filing of a verified statement of use is valid when the application is assigned to a “successor to the business of the applicant, or portion thereof, to which the mark pertains, if that business is ongoing and existing.” 15 U.S.C. § 1060(a). *See also* J. THOMAS MCCARTHY, MCCARTHY ON TRADEMARKS AND UNFAIR COMPETITION, at § 18:13 (4th ed. 2004) (stating that ITU application may be validly transferred under these circumstances).

38. *Microsoft Corp. v. Valverde Investments, Inc.*, 2004 WL 1328053 (T.T.A.B. 2004), illustrates the point. There, the validity of the assignment of an ITU application before the filing of a verified statement of use was upheld for two reasons. First, the assignment agreement provided that the assignor did not retain the ongoing and existing business and could not “continue using the mark on the goods as it had been doing.” *Id.*, at \*4. Second, in the agreement the assignee expressed the intent to acquire the business of the assignor in connection with which the assignor had a bona fide intent to use the mark and pending application. *Id.*

39. Here, the same circumstances are and were present in the transfer of the NAPSTER ITU Applications in this Court. Under the Sale Order and Asset Purchase Agreement, Roxio acquired substantially all of the assets relating to Napster, Inc.'s ongoing and existing business, including the core assets of Napster, Inc.'s internet music downloading services and related technology. See e.g. APA, § 3.3 (“The Purchased Assets, taken as a whole, **constitute all the properties, assets and rights related to the Intended Business.**” (emphasis added)). Moreover, the Court-approved Asset Purchase Agreement expressly provided that Roxio purchased all of the Debtors’ “right, title and interest in, to and under the assets properties, contract rights and Intended Business...of every kind and description,” including “all of [Debtors’] rights, title and interest in, to and under all Intellectual Property Rights owned, licensed or used by the [Debtors] (**including the goodwill of the Intended Business in which any of the marks are used**)” and “all goodwill associated with the Purchased Assets, together **with the right to represent to third parties that Buyer is the successor** to the Intended Business operated by the [Debtors][.]” APA, §§ 2.1, 2.1(b), 2.1(c) (emphasis added). And, pursuant to the Sale Order and Asset Purchase Agreement, the Debtors retained no right to further use any NAPSTER mark. See APA, § 5.7.

40. As a consequence, because the ongoing and existing business that pertained to the NAPSTER ITU Applications was transferred, it is beyond reasonable dispute that the assignment of the NAPSTER ITU Applications was valid. 15 U.S.C. § 1060(a); *Microsoft Corp.*, 2004 WL 1328053, at \*4.

IV. CONCLUSION

WHEREFORE, Movants respectfully request that the Court enter an order, substantially in the form attached hereto as Exhibit H, (i) reopening the Debtors' bankruptcy case and enforcing the Sale Order and Asset Purchase Agreement and (ii) prohibiting SightSound from further attacking or seeking to undermine the Sale Order, Asset Purchase Agreement and the validity of the transfer of the Napster Assets, including the NAPSTER Registration and the NAPSTER ITU Applications along with associated goodwill, to Roxio.

Dated: May 19, 2005  
Wilmington, Delaware

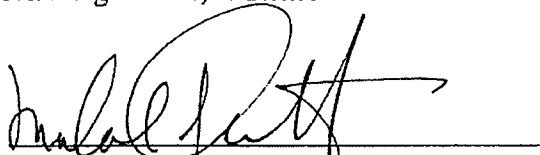

Mark D. Collins (No. 2981)  
Michael J. Merchant (No. 3854)  
RICHARDS, LAYTON & FINGER, P.A.  
One Rodney Square  
P.O. Box 551  
Wilmington, Delaware 19899  
(302) 651-7700

- and -

Michael T. Zeller (*pro hac* application pending)  
QUINN EMANUEL URQUHART OLIVER &  
HEDGES, LLP  
865 S. Figueroa Street, 10th Floor  
Los Angeles, California 90017  
Telephone: 213-443-3100  
Facsimile: 213-443-3200

- and -

Suzanne Uhland (*pro hac* application pending)  
O'MELVENY & MYERS LLP  
400 South Hope St.  
Los Angeles, California 90071  
(213) 430-6000

Attorneys for Plaintiffs  
ROXIO, INC. and NAPSTER, L.L.C.

**EXHIBIT A**

**ORIGINAL**

IN THE UNITED STATES BANKRUPTCY COURT  
FOR THE DISTRICT OF DELAWARE

IN RE:	)	Chapter 11
	)	
NAPSTER, INC.,	)	Jointly Administered
a Delaware corporation, et al.,	)	Case Nos. 02-11573 (PJW)
	)	
Debtors.	)	Hearing Date: November 27, 2002 @ 11:00 a.m.
	)	Related Pleading #398

**ORDER UNDER 11 U.S.C. §§ 105(a), 363, 365 AND 1146(c), AND FED. R. BANKR. P. 2002, 6004, 6006, AND 9014 (A) APPROVING ASSET PURCHASE AGREEMENT; (B) AUTHORIZING THE SALE OF SUBSTANTIALLY ALL OF DEBTORS' ASSETS, (C) AUTHORIZING ASSUMPTION AND ASSIGNMENT OF CERTAIN EXECUTORY CONTRACTS, AND (D) GRANTING OTHER RELATED RELIEF**

This matter having come before the Court on the motion dated November 15, 2002 (the "Motion"),<sup>1</sup> of Hobart G. Truesdell, in his capacity as the Chapter 11 Trustee (the "Trustee") for the above-captioned debtors (the "Debtors") for, inter alia, entry of an order under 11 U.S.C. §§ 105(a), 363, 365, and 1146(c) and Fed. R. Bankr. P. 2002, 6004, 6006, and 9014 (the "Sale Order") authorizing the Trustee's sale (the "Sale") of substantially all of the Debtors' assets (the "Assets"), free and clear of any mortgage, lien, pledge, charge, easement, option, right of first refusal, right of first offer, right of first use or occupancy, indenture, deed of trust, right of way, tenancy, restriction on the use of real property, restriction upon voting or transfer, encroachment, license to a third party, lease to a third party, security agreement, security interest, encumbrance or other adverse claim, restriction or limitation of any kind in respect of such property or asset or irregularities in title thereto (collectively, "Interests"), except for the Permitted Liens, pursuant to and as described in the Asset Purchase Agreement, dated as of November 15, 2002 (the "Asset Purchase Agreement"), between the Debtors and

<sup>1</sup> Unless otherwise defined, capitalized terms used herein shall have the meaning ascribed to them in the Motion or the Asset Purchase Agreement, as the case may be.

#423  
11/27/02

Roxio, Inc., as buyer (the "Buyer"), pursuant to and as described in the Asset Purchase Agreement, free and clear of all Interests except the Permitted Liens; and the Court having entered an order on November 15, 2002 (the "Procedures Order") (i) authorizing the Trustee to proceed with a sale (the "Sale") of the assets of the Debtors, (ii) establishing procedures (the "Procedures") to be employed in connection with the Sale including approval of a break-up fee, (iii) approving form and notice of the Sale, (iv) setting dates for a sale hearing and deadlines for the filing of objections to the Sale and objections to the assumption and assignment of executory contracts and unexpired leases and to cure payments proposed to be paid in connection with the Sale, and (v) granting related relief; and a hearing on the Motion having been held on November 27, 2002 (the "Sale Hearing") at which time interested parties were offered an opportunity to be heard with respect to the Motion; and the Court having reviewed and considered (i) the Motion, (ii) objections thereto, if any, (iii) the arguments of counsel made, and the evidence proffered or adduced, at the Sale Hearing; and it appearing that the relief requested in the Motion is in the best interests of the Debtors, their estates and creditors and other parties in interest; and upon the record of the Sale Hearing and these cases; and after due deliberation thereon; and good cause appearing therefor, it is hereby

FOUND AND DETERMINED THAT:<sup>2</sup>

A. The court has jurisdiction over this Motion pursuant to 28 U.S.C. §§ 157 and 1334, and this matter is a core proceeding pursuant to 28 U.S.C. § 157(b)(2)(A). Venue of these cases and the Motion in this district is proper under 28 U.S.C. §§ 1408 and 1409.

---

<sup>2</sup> Findings of fact shall be construed as conclusions of law and conclusions of law shall be construed as findings of fact when appropriate. See Fed. E. Bankr. P. 7052.



B. The statutory predicates for the relief sought in the Motion are sections 105(a), 363(b), (l), (k), (m), and (n), 365, and 1146(c) of the United States Bankruptcy Code, 11 U.S.C. §§ 101-1330, as amended (the "Bankruptcy Code") and Fed. R. Bankr. P. 2002, 6004, 6006, 9014 and 9019.

C. Proper timely, adequate and sufficient notice of the Motion, the Sale Hearing, and the Sale has been provided in accordance with 11 U.S.C. §§ 102(1), 363 and 365 and Fed. R. Bankr. P. 2002, 6004, 9014 and 9019 and in compliance with the Procedures Order, and such notice was good and sufficient, and appropriate under the particular circumstances, and no other or further notice of the Motion, the Sale Hearing or the Sale is or shall be required.

D. As demonstrated by (i) the testimony and other evidence proffered or adduced at the Sale Hearing and (ii) the representations of counsel made on the record at the Sale Hearing, the Debtors have complied with the Procedures Order.

E. The Trustee on behalf of the Debtors and each Debtor (i) have full corporate power and authority to execute the Asset Purchase Agreement and all other documents contemplated thereby and the consummation of the transactions contemplated by the Asset Purchase Agreement by the Trustee and the Debtors have been duly and validly authorized by all necessary corporate action of each of the Debtors, (ii) have all of the corporate power and authority necessary to consummate the transactions contemplated by the Asset Purchase Agreement and (iii) have taken all corporate action necessary to authorize and approve the Asset Purchase Agreement and the consummation by the Trustee and such Debtors of the transactions contemplated thereby; and no consents or approvals, other than those expressly provided for in the Asset Purchase Agreement, are required for the Trustee or the Debtors to consummate such transactions.

F. Approval of the Asset Purchase Agreement and consummation of the transactions contemplated by the Asset Purchase Agreement at this time are in the best interests of the Debtors, their creditors, their estates, and other parties in interest.

G. The Debtors have demonstrated both (i) good, sufficient, and sound business purpose and justification and (ii) compelling circumstances for the Sale pursuant to 11 U.S.C. § 363(b) prior to, and outside of, a plan of reorganization.

H. A reasonable opportunity to object or be heard with respect to the Motion and the relief requested therein has been afforded to all interested persons and entities, including: (i) the Office of the United States Trustee, (ii) counsel for Buyer, (iii) counsel for the Debtors, (iv) counsel for the Committee, (v) counsel to Bertelsmann AG; (vi) all entities who have filed and served requests for notices in these cases, (vii) all other parties-in-interest, (viii) all appropriate state and local taxing authorities which may be affected by the proposed sale and (ix) all entities that have previously submitted written bids to acquire the Debtors' assets.

I. The Asset Purchase Agreement was negotiated, proposed and entered into by the parties without collusion, in good faith, and from arm's-length bargaining positions. The Buyer is a good faith purchaser under 11 U.S.C. § 363(m) and, as such, is entitled to all of the protections afforded thereby. The Buyer will be acting in good faith within the meaning of 11 U.S.C. § 363(m) in closing the transactions contemplated by the Asset Purchase Agreement at all times after the entry of this Sale Order. Neither the Trustee nor the Buyer have engaged in any conduct that would cause or permit the Asset Purchase Agreement to be avoided under 11 U.S.C. § 363(n).

J. The consideration provided by the Buyer for the Assets pursuant to the Asset Purchase Agreement (i) is fair and reasonable, (ii) is the highest and best offer for the Assets,

(iii) will provide a greater recovery for the Debtors' creditors than would be provided by any other practical available alternative, and (iv) constitutes reasonably equivalent value and fair consideration under the Bankruptcy Code and under the laws of the United States, any state, territory, possession, or the District of Columbia.

K. The Sale must be approved and consummated promptly in order to preserve the value of the Assets.

L. The transfer of the Assets to the Buyer will be a legal, valid, and effective transfer of the Assets, and will vest the Buyer with all right, title, and interest of the Debtors to the Assets free and clear of all Interests, including any Interests (A) that purport to give to any party a right or option to effect any forfeiture, modification, right of first refusal, or termination of the Debtors' or the Buyer's interest in the Assets, or any similar rights, or (B) relating to taxes or any other liabilities arising under or out of, in connection with, or in any way relating to, the Assets, the Debtors or their operations or activities prior to the Closing Date, other than the Permitted Liens.

M. The Buyer would not have entered into the Asset Purchase Agreement and would not consummate the transactions contemplated thereby, thus adversely affecting the Debtors, their estates, and their creditors, if the sale of the Assets to the Buyer was not free and clear of all Interests of any kind or nature whatsoever (other than the Permitted Liens), or if the Buyer would, or in the future could, be liable for any of the Interests, including, without limitation, the Excluded Liabilities.

N. The Trustee may sell the Assets free and clear of all Interests of any kind or nature whatsoever because, in each case, one or more of the standards set forth in 11 U.S.C. § 363(f)(1)-(5) has been satisfied. Those holders of Interests who did not object, or who

withdrew their objections, to the Sale or the Motion are deemed to have consented pursuant to 11 U.S.C. § 363(f)(2). Those holders of Interests are adequately protected by having their Interests, if any, attach to the cash proceeds of the Sale ultimately attributable to the property against or in which they claim an Interest.

O. The transfer of the Assets to the Buyer will not subject the Buyer to any liability whatsoever with respect to the Assets, the Debtors or their operations or activities prior to the Closing Date or by reason of such transfer under the laws of the United States, any state, territory, or possession thereof, or the District of Columbia, based, in whole or in part, directly or indirectly, on any theory of law or equity, including, without limitation, any theory of successor or transferee liability.

P. The sale of the Assets to the Buyer is a prerequisite to the Trustee's ability to confirm a plan or plans under 11 U.S.C. § 1129 and to consummate such plan or plans. The Sale is a sale in contemplation of a plan and, accordingly, a transfer pursuant to 11 U.S.C. § 1146(c), which shall not be taxed under any law imposing a stamp tax or similar tax.

NOW THEREFORE, IT IS HEREBY ORDERED, ADJUDGED, AND DECREED

THAT:

General Provisions

1. The Motion is granted, as further described herein.
2. The objections of PlayMedia, Inc. <sup>is resolved,</sup> and John W. Fanning are hereby overruled as <sup>the objection of</sup> further described herein. *P/W*
3. All other objections to the Motion or the relief requested therein that have not been withdrawn, waived, or settled, and all reservations of rights included therein, are hereby overruled on the merits.

Approval of the Asset Purchase Agreement

4. The Asset Purchase Agreement, and all of the terms and conditions thereof, is hereby approved.

5. Pursuant to 11 U.S.C. § 363(b), the Trustee on behalf of the Debtors and the Debtors are authorized and directed to consummate the Sale, pursuant to and in accordance with the terms and conditions of the Asset Purchase Agreement.

6. The Trustee is authorized and directed to execute and deliver, and empowered to perform under, consummate and implement, the Asset Purchase Agreement, together with all additional instruments and documents that may be reasonably necessary or desirable to implement the Asset Purchase Agreement, and to take all further actions as may be requested by the Buyer for the purpose of assigning, transferring, granting, conveying and conferring to the Buyer or reducing to possession, the Assets, or as may be necessary or appropriate to the performance of the obligations as contemplated by the Asset Purchase Agreement.

Transfer of Assets

7. Pursuant to 11 U.S.C. §§ 105(a) and 363(f), the Assets shall be transferred to the Buyer (including without limitation the internet domain names identified on Schedule 3.6(a) of the Asset Purchase Agreement without regard to the registrant identity for such internet domain names), and upon consummation of the Asset Purchase Agreement (the "Closing") shall be, free and clear of all Interests of any kind or nature whatsoever, including without limitation any alleged Interest of any kind or nature whatsoever asserted by ~~PlayMedia, Inc.~~ or John W. Fanning, other than the Permitted Liens, with all such Interests of any kind or nature whatsoever to attach to the net proceeds of the Sale in the order of their priority, with the same validity, force

pp5

and effect which they now have as against the Assets, subject to any claims and defenses the Debtors may possess with respect thereto.

8. Except as otherwise specifically provided by the Asset Purchase Agreement or this Sale Order, all persons and entities, including, but not limited to, all debt security holders, equity security holders, governmental, tax, and regulatory authorities, lenders, trade and other creditors, holding interests of any kind or nature whatsoever against or in the Debtors or the Assets (whether legal or equitable, secured or unsecured, matured or unmatured, contingent or non-contingent, senior or subordinated), arising under or out of, in connection with, or in any way relating to, the Assets, the Debtors or their operations or activities prior to the date of the Closing (the "Closing Date"), or the transfer of the Assets to the Buyer, hereby are forever barred, estopped, and permanently enjoined from asserting against the Buyer, its successors or assigns, its property, or the Assets, such persons' or entities' interests.

9. The transfer of the Assets to the Buyer pursuant to the Asset Purchase Agreement constitutes a legal, valid, and effective transfer of the Assets, and shall vest the Buyer with all right, title, and interest of the Debtors in and to the Assets free and clear of all interests of any kind or nature whatsoever, other than the Permitted Liens, provided that, notwithstanding the foregoing, to the extent any of the Assets include CD-rom and MP3 files that contain or include copyrighted material or content or include other copyrighted material or content subject to use restrictions, Buyer shall take possession of and store such Assets but shall not use such copyrighted material or content subject to use restrictions without the consent of the applicable parties, provided further that nothing herein shall affect the rights of the Association of Independent Music and its members as Licensors until Buyer reaches written agreement with the Licensor or until further Order of the Court.

10. Notwithstanding anything to the contrary herein or in the Asset Purchase Agreement, this Order shall not authorize the conveyance or transfer of title to the Buyer in or the right of the Buyer to use or to practice (i) intellectual property including without limitation copyrighted software licensed by Oracle Corporation (whether directly or indirectly through a third party reseller) to the Debtors including any copyrighted software licensed pursuant to those certain Oracle License Agreements dated as of March 2000, December 2000 and May 2001, (ii) technology owned by PlayMedia, Inc. and licensed to the Debtors pursuant to a written non-exclusive license dated as of December 14, 2000 for property subject to registered copyrights held by or in favor of PlayMedia, Inc., (iii) technology owned by Relatable, LLC and licensed to the Debtors pursuant to that certain Technology License Agreement dated as of April 13, 2001 or (iv) copyrighted materials owned by the Association of Independent Music <sup>or its members</sup> and licensed to the Debtors pursuant to those certain Agreements and that certain Escrow Agreement dated as of June 23, 2001, that certain letter agreement dated as of December 8, 2001 and that certain warranty letter dated as of February 21, 2002.

11. Notwithstanding anything to the contrary herein or in the Asset Purchase Agreement, the Assets transferred to the Buyer shall not include (i) any claims or causes of action of the Debtors under Bankruptcy Code Sections 544, 545, 547 or 548 against Bertelsmann AG or any other claims or causes of action seeking to recover or avoid any liens granted to, transfers to or for the benefit of, or other obligations incurred in favor of any claims that the Debtors have or may have against Bertelsmann AG arising from or related to any debtor-in-possession financing provided by Bertelsmann AG or (ii) any claims or causes of action of the Debtors against Bertelsmann AG arising from or related to that certain Asset Purchase Agreement dated as of May 24, 2002 by and between the Debtors and Bertelsmann AG.

Additional Provisions

12. The consideration provided by the Buyer for the Assets under the Asset Purchase Agreement shall be deemed to constitute reasonably equivalent value and fair consideration under the Bankruptcy Code and under the laws of the United States, any state, territory, possession, or the District of Columbia.

13. The consideration provided by the Buyer for the Assets under the Asset Purchase Agreement is fair and reasonable and may not be avoided under section 363(n) of the Bankruptcy Code.

14. On the Closing Date of the Sale, each of the Debtors' creditors is authorized and directed to execute such documents and take all other actions as may be necessary to release its Interests in the Assets, if any, as such Interests may have been recorded or may otherwise exist.

15. This Sale Order (a) shall be effective as a determination that, on the Closing Date, all Interests of any kind or nature whatsoever existing as to the Debtors or the Assets prior to the Closing (other than the Permitted Liens) have been unconditionally released, discharged and terminated, and that the conveyances described herein have been effected, and (b) shall be binding upon and shall govern the acts of all entities, including, without limitation, all filing agents, filing officers, title agents, title companies, recorders of mortgages, recorders of deeds, registrars of deeds, administrative agencies, governmental departments, secretaries of state, federal, state, and local officials, registrars of internet domain names and all other persons and entities who may be required by operation of law, the duties of their office, or contract, to accept, file, register or otherwise record or release any documents or instruments, or who may be required to report or insure any title or state of title in or to any of the Assets.



16. Each and every federal, state, and local governmental agency or department, registrar of internet domain names and any other person or entity is hereby directed to accept any and all documents and instruments necessary and appropriate to consummate the transactions contemplated by the Asset Purchase Agreement.

17. If any person or entity that has filed financing statements, mortgages, mechanic's liens, lis pendens, or other documents or agreements evidencing Interests in the Debtors or the Assets shall not have delivered to the Trustee prior to the Closing Date, in proper form for filing and executed by the appropriate parties, termination statements, instruments of satisfaction, releases of all Interests which the person or entity has with respect to the Debtors or the Assets or otherwise, then (a) the Trustee is hereby authorized and directed to execute and file such statements, instruments, releases and other documents on behalf of the person or entity with respect to the Assets and (b) the Buyer is hereby authorized to file, register, or otherwise record a certified copy of this Sale Order, which, once filed, registered, or otherwise recorded, shall constitute conclusive evidence of the release of all Interests in the Assets of any kind or nature whatsoever.

18. All entities who are presently, or on the Closing Date may be, in possession of some or all of the Assets are hereby directed to surrender possession of the Assets to the Buyer on the Closing Date.

19. The Buyer shall have no liability or responsibility for any liability or other obligation of the Debtors arising under or related to the Assets or otherwise other than for the Permitted Liens. Without limiting the generality of the foregoing, and except as otherwise specifically provided herein and in the Asset Purchase Agreement, the Buyer shall not be liable for any claim against the Debtors or any of their predecessors or affiliates, and the Buyer shall

have no successor or transferee liabilities of any kind or character whether known or unknown as of the Closing Date, now existing or hereafter arising, whether fixed or contingent, with respect to the Debtors or any obligations of the Debtors arising prior to the Closing Date, including, but not limited to, liabilities on account of any taxes arising, accruing, or payable under, out of, in connection with, or in any way relating to the Assets, the Debtors or their operations or activities prior to the Closing Date.

20. Under no circumstances shall the Buyer be deemed a successor of or to the Debtors for any Interest against or in the Debtors or the Assets of any kind or nature whatsoever except pursuant to the Permitted Liens. The sale, transfer, assignment and delivery of the Assets shall not be subject to any Interests, and Interests of any kind or nature whatsoever (other than the Permitted Liens) shall remain with, and continue to be obligations of, the Debtors. All persons holding Interests against or in the Debtors or the Assets of any kind or nature whatsoever shall be, and hereby are, forever barred, estopped, and permanently enjoined from asserting, prosecuting, or otherwise pursuing such Interests of any kind or nature whatsoever against the Buyer, its property, its successors and assigns, or the Assets with respect to any Interest of any kind or nature whatsoever such person or entity had, has, or may have against or in the Debtors, their estates, officers, directors, shareholders, or the Assets. Following the Closing Date, no holder of an Interest in the Debtors shall interfere with the Buyer's title to or use and enjoyment of the Assets based on or related to such Interest, or any actions that the Debtors may take in their Chapter 11 cases.

21. Subject to and except as otherwise provided in the Procedures Order, any amounts that become payable to the Buyer by the Debtors pursuant to the Asset Purchase Agreement or any of the documents delivered by the Debtors pursuant to or in connection with the Asset

Purchase Agreement shall (a) constitute allowed superpriority administrative expense claims against the Debtors' estates with priority over any and all administrative expenses of the kind specified in Bankruptcy Code Sections 503(b) and 507(b) and pursuant to the priorities set forth in the final order approving the Loan Agreement between Napco Acquisition, LLC and the Debtors entered on November 1, 2002 and (b) be paid by the Debtors in the time and manner as provided in the Asset Purchase Agreement, without further order of this Court.

22. This Court retains jurisdiction to enforce and implement the terms and provisions of the Asset Purchase Agreement, all amendments thereto, any waivers and consents thereunder, and of each of the agreements executed in connection therewith in all respects, including, but not limited to, retaining jurisdiction to (a) compel delivery of the Assets to the Buyer, (b) resolve any disputes arising under or related to the Asset Purchase Agreement, except as otherwise provided therein, (c) interpret, implement, and enforce the provisions of this Sale Order, and (d) protect the Buyer against (i) any of the Excluded Liabilities or (ii) any Interests in the Debtors or the Assets, of any kind or nature whatsoever, attaching to the proceeds of the Sale.

23. Nothing contained in any plan of reorganization or liquidation confirmed in these cases or any order of this Court confirming such plan shall conflict with or derogate from the provisions of the Asset Purchase Agreement or the terms of this Sale Order.

24. The transfer of the Assets to Buyer pursuant to the Sale shall not subject the Buyer to any liability (other than the Permitted Liens) with respect to the Assets, the Debtors or their operations or activities prior to the Closing Date or by reason of such transfer under the laws of the United States, any state, territory, or possession thereof, or the District of Columbia, based, in whole or in part, directly or indirectly, on any theory of law or equity, including, without limitation, any theory of successor or transferee liability.

25. The transactions contemplated by the Asset Purchase Agreement are undertaken by the Buyer in good faith, as that term is used in section 363(m) of the Bankruptcy Code, and accordingly, the reversal or modification on appeal of the authorization provided herein to consummate the Sale shall not affect the validity of the Sale to the Buyer, unless such authorization is duly stayed pending such appeal. In the absence of a stay pending appeal, if the Buyer elects to close under the Asset Purchase Agreement at any time after entry of this Sale Order, then, with respect to the Sale, the Buyer is a purchaser in good faith of the Assets, and is entitled to all of the protections afforded by section 363(m) of the Bankruptcy Code if this Sale Order or any authorization contained herein is reversed or modified on appeal.

26. The terms and provisions of the Asset Purchase Agreement and this Sale Order shall be binding in all respects upon, and shall inure to the benefit of, the Debtors, their estates, and their creditors, the Buyer, and their respective affiliates, successors and assigns, and any affected third parties including, but not limited to, all persons asserting Interests in the Assets to be sold to the Buyer pursuant to the Asset Purchase Agreement (including any claims with respect to the Excluded Liabilities), notwithstanding any subsequent appointment of any trustee(s) under any chapter of the Bankruptcy Code, as to which trustee(s) such terms and provisions likewise shall be binding.

~~27. This Sale Order shall not authorize the transfer of, and the Buyer shall not, as a result of the Sale, have any rights to the following asset: the right and interest to the file security software developed by Playmedia Systems, Inc. ("Playmedia") for the Debtors for a secure player including all program code and other documentation prepared by Playmedia for such software and further including all right and interest to such software under 17 U.S.C. § 106, (the "Playmedia Software"). The Playmedia Software shall not be considered Assets or Interests for~~

*27. Replaced with Playmedia Addendum attached hereto and incorporated herein by reference.*

~~purposes of this Sale Order, unless and until the Court enters a further Order, on appropriate motion or complaint, after notice and a hearing, holding that either (a) the Playmedia Software (or an exclusive license therein) is owned by the Debtors or (b) the Debtors are authorized to transfer an interest in or right to the Playmedia Software under section 365 of the Bankruptcy Code.~~

ppw

28. The failure specifically to include any particular provisions of the Asset Purchase Agreement in this Sale Order shall not diminish or impair the effectiveness of such provision, it being the intent of the Court that the Asset Purchase Agreement be authorized and approved in its entirety.

29. The Asset Purchase Agreement and any related agreements, documents or other instruments may be modified, amended or supplemented by the parties thereto, in a writing signed by both parties, and in accordance with the terms thereof, without further order of the Court, provided that any such modification, amendment or supplement does not have a material adverse effect on the Debtors' estates or Bertelsmann.

30. The transfer of the Assets pursuant to the Sale is a transfer pursuant to section 1146(c) of the Bankruptcy Code, and accordingly shall not be taxed under any law imposing a

U.S.B

stamp tax or a sale, transfer, or any other similar tax, provided that any such tax shall be deposited into escrow for the benefit of any appropriate taxing authority, entity and shall become payable only in the event of reorganization or liquidation as confirmed herein.

ppw

31. This Sale Order shall be effective and enforceable immediately upon entry. The stay otherwise imposed by Fed. R. Bankr. P. 6004(g) and 6006(d) is waived. Time is of the essence in closing the transaction and the Debtors and the Buyer intend to close the Sale as soon as possible. Therefore, any party objecting to this Sale Order must exercise due diligence in filing an appeal and pursuing a stay or risk their appeal being foreclosed as moot.

(DUB)

32. The provisions of this Sale Order are nonseverable and mutually dependent.

Dated: Wilmington, Delaware  
Nov. 27, 2002

  
UNITED STATES BANKRUPTCY JUDGE

## EXHIBIT A

### DEVELOPMENT EXHIBIT

#### A. Deliverables

PlayMedia shall provide Napster with the following items, developed to interface with/function with the Napster Service and/or the Applications in accordance with the Napster System Specifications:

##### 1. Fillmore Stream Obfuscation Algorithms & Implementation

The Fillmore Stream Obfuscation Algorithms & Implementation will scramble an MP3 file's data stream when encoding such file into a file formatted in the .NAP Format, making the encoded file only able to be played back by the Application. This marks a permanent change to the MP3 file, ensuring that any non .NAP Format compliant applications that attempt to render files formatted in the .NAP Format are unable to do so.

Code Type to be provided to Napster: Object, Source\*

Documentation to be provided to Napster: Developer Manual, Code Documentation

\*Notwithstanding anything to the contrary in the Agreement, the source code specified above may only be used by Napster or its sublicensees for the purposes of supporting, maintaining, upgrading or otherwise enhancing Applications or the Napster Service.

##### 2. AES Obfuscation Algorithm & Implementation

AES, a publicly available encryption scheme, will be adapted and modified by PlayMedia to encrypt MP3 files into files formatted in the .NAP Format. Files formatted in the .NAP Format will be both encrypted and decrypted using a scheme based on the modified AES.

Code Type to be provided to Napster: Source, Object

Documentation to be provided to Napster: Developer Manual, Code Documentation

##### 3. Fillmore Track Specification Implementation

Development of software that encodes a file and arranges the various data elements associated with the file (e.g., header information, certificate, MD5, encoded content).

Code Type to be provided to Napster: Source, Object

Documentation to be provided to Napster: Developer Manual, Code Documentation

##### 4. ID3 Tag Parsing Engine

Provides for the Applications to read the metadata contained in the ID3 tags of users' files. Allows Napster to find and retrieve security measures inserted into the ID3 tag frames.

Code Type to be provided to Napster: Source, Object

Documentation to be provided to Napster: Developer Manual, Code Documentation

##### 5. NewArk™ Handling Library

NewArk (a trademark of PlayMedia) provides for the decoding of an encrypted files in the .NAP Format, leveraging an encryption API provided from Secude, another sub-contractor for DWS, which API utilizes PlayMedia's AES obfuscation algorithm. NewArk is an enhanced playback library that coordinates all the necessary services and effects for playback of files formatted in the .NAP Format.

*ppw*

Code Type to be provided to Napster: Object

Documentation to be provided to Napster: Developer Manual, Code Documentation, Sample application (in source code)

**6. AMP Decoding Engine for Windows and MAC.OSX**

Provides basic and obfuscated MP3 playback capabilities for Napster for Windows and MAC OSX. The resulting playback engine will be a modified adaptation of the basic AMP engine for playback of files formatted in the .NAP Format.

Code Type to be provided to Napster: Object

Documentation to be provided to Napster: None

*SA  
RWR  
LINUX*

*AMP*  
The Deliverables apply only to the Windows PC and MAC OSX platforms, MPEG-1 and MPEG-2 decoders, Layers II-III, and are not designed to work with any other system. It is understood that the Deliverables do not include technology that enables the playback of any third-party applications, e.g., plug-ins, on any platform (including, without limitation, personal computers or embedded systems). The parties agree that, subject to termination of this Agreement as provided in Paragraph 8.2 of the Agreement, PlayMedia and Napster have agreed to similar development work for Napster for a Macintosh based version of the Napster software and system as set forth above.

**B. Napster Deliverables:**

Napster shall provide PlayMedia with the following items:

**1. Napster System Specifications**

The Napster System Specifications include, but are not limited to, the following: (a) design documentation and architecture of the Napster Service and Applications; and (b) technical and other specifications relating to distribution, playback, display or other performance of files formatted in the .NAP Format, including, without limitation the Filmore Track Specification, which defines the manner in which the Napster Service encodes a file and arranges the various data elements associated with the file (e.g., header information, certificate, MD5, encoded content).

**C. Payments:**

PlayMedia has been performing development work on an hourly basis since January 23, 2001. To date Napster has paid PlayMedia, as set forth below, for all development work performed through September 30, 2001. The parties agree that PlayMedia will continue to deliver development services at the rates set forth herein and pursuant to the monthly schedule provided to PlayMedia's Project Manager by Napster's Project Manager.

- 1) **Payment for Implementation of Effects Nodes.** The parties acknowledge that Napster has paid PlayMedia \$20,000 for PlayMedia's completed work enabling immediate implementation of the Effects Nodes developed by PlayMedia under the Developer SDK Base License Agreement between Napster and PlayMedia dated December 14, 2000.



**EXHIBIT B**

---

ASSET PURCHASE AGREEMENT

dated as of

November 15, 2002

Between

NAPSTER, INC.,

NAPSTER MUSIC COMPANY, INC.,

NAPSTER MOBILE COMPANY, INC.

AND

ROXIO, INC

**TABLE OF CONTENTS**

**Page**

**ARTICLE 1**

**DEFINITIONS**

Section 1.1 Definitions..... 1

**ARTICLE 2**

**PURCHASE AND SALE**

Section 2.1 Purchase and Sale ..... 5  
Section 2.2 Excluded Assets ..... 6  
Section 2.3 Assumption of Liabilities..... 7  
Section 2.4 Excluded Liabilities ..... 7  
Section 2.5 Assignment of Contracts and Rights..... 8  
Section 2.6 Consideration ..... 8  
Section 2.7 Allocation..... 8  
Section 2.8 Closing ..... 9

**ARTICLE 3**

**REPRESENTATIONS AND WARRANTIES OF SELLERS**

Section 3.1 Organization and Standing; Authority ..... 10  
Section 3.2 No Conflicts; Consents ..... 10  
Section 3.3 Sufficiency of and Title to the Purchased Assets..... 10  
Section 3.4 Required Consents ..... 11  
Section 3.5 Material Contracts..... 11  
Section 3.6 Intellectual Property..... 12  
Section 3.7 Litigation..... 14  
Section 3.8 Compliance with Laws and Court Orders..... 14  
Section 3.9 Brokers and Finders ..... 14  
Section 3.10 Subsidiaries..... 14  
Section 3.11 No Warranties ..... 14

**ARTICLE 4**

**REPRESENTATIONS AND WARRANTIES OF BUYER**

Section 4.1 Organization and Standing; Authority ..... 15  
Section 4.2 No Conflicts; Consents ..... 15  
Section 4.3 Availability of Funds ..... 15  
Section 4.4 Brokers and Finders ..... 16  
Section 4.5 Payments ..... 16

**TABLE OF CONTENTS**  
**(continued)**

	<b>Page</b>
Section 4.6 No Warranties .....	16
Section 4.7 Actions and Proceedings, etc. ....	16

**ARTICLE 5**

**COVENANTS OF SELLERS**

Section 5.1 Conduct of the Intended Business.....	16
Section 5.2 Access to Information; Assistance.....	16
Section 5.3 Notices of Certain Events .....	17
Section 5.4 Bankruptcy Court Approval.....	17
Section 5.5 Permits .....	18
Section 5.6 Cure Amounts .....	18
Section 5.7 Name Changes .....	19

**ARTICLE 6**

**COVENANTS OF BUYER**

Section 6.1 Confidentiality .....	19
Section 6.2 No Additional Representations .....	20
Section 6.3 Supplemental Disclosure .....	20
Section 6.4 Assignment to Affiliate.....	20
Section 6.5 Buyer's Cooperation .....	20
Section 6.6 Delivery of List of Assumed Contracts .....	20

**ARTICLE 7**

**COVENANTS OF ALL PARTIES**

Section 7.1 Commercially Reasonable Efforts; Further Assurances .....	20
Section 7.2 Certain Filings.....	21
Section 7.3 Public Announcements .....	21
Section 7.4 Post-Closing Access to Books and Records .....	21

**ARTICLE 8**

**TAX MATTERS**

Section 8.1 Tax Matters .....	22
Section 8.2 Tax Cooperation; Allocation of Taxes.....	22
Section 8.3 Transfer Taxes .....	23
Section 8.4 Tax Payments Made by Buyer.....	23

**TABLE OF CONTENTS**  
**(continued)**

**Page**

**ARTICLE 9**

**CONDITIONS TO CLOSING**

Section 9.1	Conditions to Buyer's Obligations.....	24
Section 9.2	Conditions to Obligation of Sellers.....	24
Section 9.3	Frustration of Conditions .....	25

**ARTICLE 10**

**SURVIVAL**

Section 10.1	Survival.....	25
--------------	---------------	----

**ARTICLE 11**

**TERMINATION**

Section 11.1	Grounds for Termination .....	25
Section 11.2	Effect of Termination.....	26

**ARTICLE 12**

**MISCELLANEOUS**

Section 12.1	Notices .....	26
Section 12.2	Amendments and Waivers .....	28
Section 12.3	Fees and Expenses .....	28
Section 12.4	Successors and Assigns.....	28
Section 12.5	Governing Law .....	28
Section 12.6	Counterparts; Effectiveness .....	28
Section 12.7	Entire Agreement; Third Party Beneficiaries .....	28
Section 12.8	Captions .....	29
Section 12.9	Severability .....	29
Section 12.10	Consent to Jurisdiction.....	29
Section 12.11	WAIVER OF JURY TRIAL.....	29

## ASSET PURCHASE AGREEMENT

ASSET PURCHASE AGREEMENT dated as of November 15 2002 between Napster, Inc., a Delaware corporation ("Napster"), Napster Music Company, Inc., a Delaware corporation and a wholly-owned subsidiary of Napster ("Napster Music"), Napster Mobile Company, Inc., a Delaware corporation and a wholly-owned subsidiary of Napster ("Napster Mobile") and, together with Napster and Napster Music, the "Sellers", and Roxio, Inc., a Delaware corporation ("Buyer").

### WITNESSETH:

WHEREAS, on June 3, 2002 (the "Petition Date"), Sellers filed voluntary petitions for relief pursuant to chapter 11 of The Bankruptcy Reform Act of 1978, as codified in title 11 of the United States Code §§ 101-1330 (as amended, the "Bankruptcy Code") in the United States Bankruptcy Court for the District of Delaware (the "Bankruptcy Court") and such case (the "Bankruptcy Case") is presently pending under Case No. 02-11573 (PJW) (Jointly Administered);

WHEREAS, on October 2, 2002 the Bankruptcy Court entered an order appointing Hobart G. Truesdell as the Chapter 11 Trustee of the Sellers and their estates (the "Trustee") pursuant to Section 1104 of the Bankruptcy Code; and

WHEREAS, subject to approval of the Bankruptcy Court, as set forth herein, Buyer desires to acquire from Sellers, and Sellers desire to sell, convey, transfer and assign to Buyer, the Purchased Assets (as defined below), together with certain obligations and liabilities, all in the manner and subject to the terms and conditions set forth herein and in accordance with Sections 363 and 365 and other applicable provisions of the Bankruptcy Code.

NOW, THEREFORE, the parties hereto agree as follows:

### ARTICLE 1 DEFINITIONS

#### Section 1.1 Definitions.

(a) The following terms, as used herein, have the following meanings:

"Affiliate" of any Person shall mean any Person directly or indirectly controlling, controlled by, or under common control with, such Person; *provided*, that for the purposes of this definition, "control" (including, with correlative meanings, the terms "controlled by" and "under common control with"), as used with respect to any Person, shall mean the possession, directly or indirectly, of the power to direct or cause the direction of the management and policies of such Person, whether through the ownership of voting securities, membership or partnership interests, election or appointment of directors, by contract or otherwise.

**"Agreement"** means this Agreement and all exhibits and schedules attached hereto, as amended, consolidated, supplemented, novated or replaced by the parties from time to time, as the same may be amended from time to time.

**"Allocation Statement"** shall have the meaning given such term in Section 2.7.

**"Apportioned Obligations"** means all real property taxes, personal property taxes and similar *ad valorem* obligations levied with respect to the Purchased Assets for a taxable period which includes (but does not end on) the Closing Date.

**"Assigned Intellectual Property"** means any and all Intellectual Property Rights, which Debtors have been validly assigned and to which Debtors have obtained all right, title and interest, including but not limited to the Intellectual Property Rights subject to that certain Assignment of Technology Agreement, as amended, by and between Napster and John Fanning, which Intellectual Property Rights include without limitation domain names, trademarks, logos and trademark/patents, the internet domain name napster.net, and the Napster "cat" logo.

**"Assumed Contracts"** means Sellers' Contracts identified on Schedule 2.1(a).

**"Assumed Liabilities"** shall have the meaning given such term in Section 2.3.

**"Bankruptcy Case"** shall have the meaning given to such term in the recitals to this Agreement.

**"Bankruptcy Code"** shall have the meaning given to such term in the recitals to this Agreement.

**"Bankruptcy Court"** shall have the meaning given to such term in the recitals to this Agreement.

**"Books and Records"** means all books of account and other financial records (including, without limitation, accountant's work papers) pertaining to the Sellers' Intended Business and the Purchased Assets.

**"Breakup Fee"** means the amount in cash equal to \$200,000.

**"business day"** means any day, other than a Saturday, Sunday or a day on which banks located in New York City shall be authorized or required by law to close.

**"Buyer"** shall have the meaning given such term in the Preamble.

**"Cash Amount"** means an amount in cash equal to \$5 million. The Cash Amount shall be increased by the Equipment Amount if Buyer elects to purchase the Equipment pursuant to Section 2.1(i).

**"Closing"** shall have the meaning given such term in Section 2.8.

**"Closing Date"** means the date on or as of which the Closing occurs.

"Consideration" shall have the meaning given such term in Section 2.6.

"Contracts" means all commitments, contracts, leases, licenses, agreements and understandings, written or oral, relating to the Sellers' assets or the operations of the Sellers' Intended Business to which any Seller is a party or by which it or any of such Seller's assets are bound.

"Contracts Notice" shall have the meaning given to such term in Section 2.1(a).

"Cure Amount" shall have the meaning given such term in Section 5.6.

"Equipment" shall have the meaning given such term in Section 2.1(i).

"Equipment Amount" means \$155,000.

"Excluded Assets" shall have the meaning given such term in Section 2.2.

"Excluded Contracts" means all contracts of the Sellers not identified on Schedule 2.1(a).

"Excluded Liabilities" shall have the meaning given such term in Section 2.4.

"Final Order" means an order or judgment entered and adopted by the Bankruptcy Court as to which (i) the time for appeal has expired and a notice of appeal has not been timely filed, or (ii) any appeal taken has been finally dismissed or determined and is not subject to further review.

"Governmental Entity" means any federal, state, county, municipal, local, foreign, international, regional, or other governmental authority or any court of competent jurisdiction, administrative agency or commission or other governmental authority, board, body or instrumentality, domestic or foreign.

"Intellectual Property Rights" means all patents, patent applications and other patent rights (including any divisions, continuations, continuations-in-part, requests for continued examinations, substitutions, or reissues and reexaminations thereof, whether or not any such applications are modified, withdrawn or resubmitted), trademarks, trade dress, service marks, corporate names, domain names, trade names, brand names, service marks, service names, mask works, assumed names, logos, inventions, trade secrets, designs, technology, know-how, processes, procedures, techniques, methods, inventions, proprietary data, formulae, research and development data, computer software programs and other intangible property, copyrights (including all variants thereof and any registration or applications for registration of any of the foregoing and non-registered copyrights), including all files, manuals, documentation and source and object codes related to any of the foregoing, or any other similar type of proprietary intellectual property right (whether or not patentable or subject to copyright, mask work or trade secret protection) and the Assigned Intellectual Property, in each case which is owned, licensed or used by any Seller.

"Intended Business" means the Sellers' intended business of operating a legal



secure online subscription service for the distribution and sharing of music and other content.

"IRC" means the Internal Revenue Code of 1986, as amended from time to time and the Treasury regulations promulgated and the rulings issued thereunder.

"Lien" means, with respect to any property or asset, any mortgage, lien, pledge, charge, easement, option, right of first refusal, right of first offer, right of first use or occupancy, indenture, deed of trust, right of way, tenancy, restriction on the use of real property, restriction upon voting or transfer, encroachment, license to a third party, lease to a third party, security agreement, security interest, encumbrance or other adverse claim, restriction or limitation of any kind in respect of such property or asset or irregularities in title thereto. For the purposes of this Agreement, a person shall be deemed to own subject to a Lien any property or asset which it has acquired or holds subject to the interest of a vendor or lessor under any conditional sale agreement, capital lease or other title retention agreement relating to such property or asset.

"New DIP Loan" means the loan or loans made by the Buyer to the Sellers under that certain Loan Agreement, dated as of October 18, 2002, between the Buyer, as Lender, and the Sellers, as Borrowers, and approved by the Bankruptcy Court on November 1, 2002.

"Permitted Liens" means those liens set forth on Schedule 2.1.

"Person" means and includes any individual, partnership, association, joint venture, corporation, limited liability company, limited liability partnership, trust, trustee, any other entity or organization and any Government Entity.

"Petition Date" shall have the meaning given such term in the recitals to this Agreement.

"Post-Closing Tax Period" means the number of days of a Tax period after the Closing Date.

"Pre-Closing Tax Period" means any Tax period (or portion thereof) ending on or before the close of business on the Closing Date.

"Promissory Note" means that certain promissory note in the principal amount of up to \$250,000 made by the Sellers and delivered to the Buyer under the New DIP Loan.

"Purchased Assets" shall have the meaning given such term in Section 2.1.

"Required Consents" shall have the meaning given such term in Section 3.4.

"Sale Motion" shall have the meaning given such term in Section 5.4(b).

"Sale Order" means an order issued by the Bankruptcy Court in a form reasonably satisfactory to the Buyer and substantially in the form attached hereto as Exhibit C, which shall approve the transactions contemplated by this Agreement.

"Sale Procedures Motion" shall have the meaning given such term in Section

5.4(a).

"Sale Procedures Order" shall have the meaning given such term in Section

5.4(a).

"Scheduled Intellectual Property" shall have the meaning given such term in Section 3.6(a).

"Sellers" shall have the meaning given such term in the Preamble.

"Tax" or "Taxes" means all taxes, assessments, charges, duties, fees, levies or other governmental charges including, without limitation, all federal, state, local, foreign and other net or gross income, gross receipts, alternative or add-on minimum tax, franchise, profits, capital gains, capital, transfer, sales, use, *ad valorem*, occupation, premium, property, excise, severance, environmental (including taxes under IRC section 59A) or windfall profits tax, stamp, license, payroll, employment, withholding and other taxes, assessments, charges, customs, duties, fees, levies or other governmental assessments or charges of any kind whatsoever (whether payable directly or by withholding and whether or not requiring the filing of a return), all estimated taxes, deficiency assessments, additions to tax, penalties and interest, whether disputed or not.

"Trustee" shall have the meaning given such term in the recitals to this Agreement.

"Trustee's Knowledge" means Trustee's actual knowledge after undertaking reasonable diligence since the Trustee's appointment and, with respect to the period prior to the Trustee's appointment, such knowledge after having both interviewed the former chief financial officer of Napster, Carolyn Jensen and reviewed 1) pertinent documents identified as key documents in such interviews and 2) all documents filed in the Bankruptcy Case.

"Warrant" means the right and option granted by Roxio pursuant to the Warrant Agreement in substantially the form as attached hereto as Exhibit B, provided that the transferability provision of the Warrant Agreement shall not be revised without the consent of Buyer in its sole and absolute discretion, as part of the Consideration to the Sellers to acquire up to 100,000 shares of common stock of Roxio for a price equal to [~~\$~~<sup>3.125</sup>] per share, which is the average of closing stock prices for the twenty trading days preceding the day before the execution of this Agreement, and expiring on November 15, 2005.

"Warrant Agreement" means that certain Warrant Agreement, dated as of November 15, 2002, by and between Roxio and Napster.

## ARTICLE 2 PURCHASE AND SALE

Section 2.1 Purchase and Sale. Except as otherwise provided below, upon the terms and subject to the conditions of this Agreement, Buyer agrees to purchase from Sellers and

---

Sellers agree to sell, transfer, convey, assign and deliver, or cause to be sold, transferred, conveyed, assigned and delivered, to Buyer at Closing, free and clear of all Liens, other than the Permitted Liens set forth on Schedule 2.1, all of Sellers' right, title and interest in, to and under the assets, properties, contract rights and Intended Business as of the commencement of the Bankruptcy Case, of every kind and description, wherever located, real, personal or mixed, tangible or intangible, owned, held or used by the Sellers in the conduct of their Intended Business as the same shall exist on the Closing Date, other than the Excluded Assets, but including, without limitation, (a) all assets shown on Schedule B of the Schedule of Assets and Liabilities filed by each of the Sellers and Schedule 2.1 hereto and (b) all right, title and interest of Sellers in, to and under the following (collectively, the "Purchased Assets"):

(a) all of Sellers' right, title and interest in, to and under all of Sellers' executory contracts and unexpired leases identified as an Assumed Contract on Schedule 2.1(a) or on a written notice provided by Buyer to Sellers at any time or from time to time prior to the Closing (the "Contracts Notice"). Any executory contracts or unexpired leases not identified as an assumed contract on Schedule 2.1(a) are referred to herein as the "Excluded Contracts";

(b) all of Sellers' rights, title and interest in, to and under all Intellectual Property Rights owned, licensed or used by the Sellers (including the goodwill of the Intended Business in which any of the marks are used), including the items listed in Schedule 2.1(b);

(c) except as provided in Section 2.2(i), all of Sellers' right, claims, credits, causes of action or rights of setoff against third parties relating to the Purchased Assets, including, without limitation, unliquidated rights under manufacturers' and vendors' warranties and rebates;

(d) all Books and Records, files and papers, whether in hard copy or computer format related to the Purchased Assets, including, without limitation, engineering information, sales and promotional literature, manuals and data, sales and purchase correspondence, lists of present and former suppliers, lists of present and former customers, personnel and employment records, and any information relating to Tax imposed on the Purchased Assets;

(e) all computer software programs and data used in connection with the Purchased Assets;

(f) all goodwill associated with the Purchased Assets, together with the right to represent to third parties that Buyer is the successor to the Intended Business operated by the Sellers;

(g) any non-disclosure agreements entered into between any of the Sellers and any current or former employees or consultants or any other third parties to protect confidential information of Sellers;

(h) any Intellectual Property Rights assignment agreements, including, without limitation, any agreements executed by employees or agents acknowledging the proprietary interest of Sellers in any Intellectual Property Rights; and

(i) if Buyer notifies Seller on or before November 26, 2002, the Purchased Assets will include the equipment as identified on Schedule 2.1(i) (the "Equipment") and the Cash Amount will be increased by the Equipment Amount.

Section 2.2 Excluded Assets. Notwithstanding anything to the contrary herein or otherwise, Buyer expressly understands and agrees that the following assets and properties of Sellers (the "Excluded Assets") shall be excluded from the Purchased Assets:

(a) all of Sellers' cash and cash equivalents on hand and in banks and security deposits, prepaid expenses and similar credit arrangements except for any deposits or prepaid amounts in respect of Assumed Contracts or other Purchased Assets;

(b) insurance policies;

(c) the Excluded Contracts;

(d) bank accounts (to be identified by Sellers at least 5 business days prior to Closing) necessary to administer the estate and the related banking records and check stock;

(e) capital stock of Sellers and agreements related thereto;

(f) minute and stock books of Sellers and any other documents relating to the organization, maintenance and existence of Sellers as corporations;

(g) all machinery, equipment, furniture, office equipment, communications equipment, vehicles, inventory, supplies and other, similar tangible property owned by the Sellers and not subject to any lease, except the Equipment, if any, Buyer elects to purchase;

(h) Tax records; and

(i) any rights, defenses, claims, demands, actions, deposits and causes of action that Sellers may have against any Person other than any such rights, defenses, claims, demands, actions, deposits or causes of action (x) against Buyer or its Affiliates or (y) related to or arising from a Purchased Asset, Assumed Contract or Assumed Liability. For the avoidance of doubt, Sellers retain all rights, claims and causes of action based on alleged antitrust, competition and related violations or theories against (i) the individuals and entities identified in Schedule 2.2(i),

(ii) the parties to the copyright infringement actions identified under the category of "Pending Legal Actions, Suits and Proceedings" in Schedule 2.2(i) and (iii) any other record labels or music publishers.

**Section 2.3 Assumption of Liabilities.** Upon the terms and subject to the conditions of this Agreement, at the Closing Buyer will assume only the following obligations of Sellers (the "Assumed Liabilities"), and no others: all liabilities and obligations of any Seller from and after the Closing Date under each Assumed Contract provided that the relevant Seller has arranged for the payment of the Cure Amount.

**Section 2.4 Excluded Liabilities.** Notwithstanding any provision in this Agreement, Buyer is assuming only the Assumed Liabilities and is not assuming any other liability or obligation of any Seller (or any predecessor owner of all or part of such Seller's business and assets) of whatever nature whether presently in existence or arising hereafter, including, without limitation, any liability for any claim, action, suit or proceeding pending against, or judgment against, any Seller (including the Purchased Assets) as of the Closing Date. All such other liabilities and obligations shall be retained by and remain obligations and liabilities of such Seller (all such liabilities and obligations not being assumed being herein referred to as the "Excluded Liabilities"). Notwithstanding any provision in this Agreement or any other writing to the contrary, Excluded Liabilities include, without limitation:

(a) any liability or obligation arising out of any action, suit, proceeding, or investigation pending or threatened as of, or arising out of or relating to any event or condition occurring or existing prior to, the Closing, including, without limitation, the items described in Schedule 3.7;

(b) any liability or obligation arising out of or relating to any violation of any law, rule, regulation, judgment, injunction, order or decree occurring or arising out of or relating to any event or condition occurring or existing prior to the Closing;

(c) any liability or obligation of any Seller, or any member of any consolidated, affiliated, combined or unitary group of which any Seller is or has been a member, for Taxes; provided that Apportioned Obligations shall be paid in the manner set forth in Section 8.2;

(d) any liability or obligation for (i) all costs and expenses incurred or owed in connection with the administration of the Chapter 11 Case (including the U.S. Trustee fees, the fees and expenses of attorneys, accountants, financial advisors, consultants and other professionals retained by Sellers, the creditors' committee, the postpetition lenders or the prepetition lenders incurred or owed in connection with the administration of the Chapter 11 Case) and (ii) all costs and expenses of Sellers in connection with the transactions contemplated under this Agreement, and any contracts related thereto;

(e) any accounts payable of any Seller;

(f) any liability or obligation for or relating to indebtedness for borrowed money;

(g) any liability or obligation relating to an Excluded Asset;

(h) any liabilities, commitments or obligations that arise (whether under the Assumed Contracts or otherwise) with respect to the Assets or the use thereof on or prior to the Closing Date or relate to periods on or prior to the Closing Date or are to be observed, paid, discharged or performed on or prior to the Closing Date (in each case, including any liabilities that result from, relate to or arise out of tort or other product liability claims);

(i) any liability or obligation of any kind under any Contract that is not an Assumed Contract;

(j) any liability or obligation for fraud, breach, misfeasance or under any other theory relating to any Seller's conduct, performance or non-performance under any agreement; and

(k) any liabilities set forth on Schedule 2.4.

Section 2.5 Assignment of Contracts and Rights. Subject to the approval of the Bankruptcy Court and pursuant to the Sale Order, the Assumed Contracts will be assumed by Sellers and assigned to Buyer on the Closing Date under Section 365 of the Bankruptcy Code. All Assumed Contracts shall be assigned to and assumed by Buyer at Closing. Sellers and Buyer will use their commercially reasonable efforts (but without any payment of money by Sellers or Buyer) to obtain the consent of the other parties to any such Purchased Asset, Assumed Contract or any claim or right or any benefit arising thereunder for the assignment thereof to Buyer as Buyer may request. If such consent is not obtained, or if an attempted assignment thereof would be ineffective or would adversely affect the rights of Sellers thereunder so that Buyer would not in fact receive all such rights, Sellers and Buyer will cooperate in a mutually agreeable arrangement under which Buyer would, to the extent permitted by applicable law, obtain the benefits and assume the obligations thereunder in accordance with this Agreement. Sellers will, to the extent permitted by applicable law, promptly pay to Buyer when received all monies received by Sellers under any Purchased Asset, Assumed Contract or any claim or right or any benefit arising thereunder, except to the extent the same represents an Excluded Asset.

Section 2.6 Consideration. The consideration for the Purchased Assets (the "Consideration") consists of (i) the Cash Amount, (ii) the Cure Amount, (iii) the Warrant, (iv) forgiveness and discharge of the Sellers' obligations to pay principal and interest under the Promissory Note and the New DIP Loan, and the (v) Assumed Liabilities. If Buyer elects to

purchase the Equipment pursuant to Section 2.1(i) the Cash Amount shall be increased by the Equipment Amount. The Consideration shall be paid as provided in Section 2.8.

**Section 2.7 Allocation.** Sellers and Buyer agree to allocate the Consideration in accordance with the allocation set forth on Schedule 2.7 hereto (the "Allocation Statement"). The Allocation Statement shall be delivered to the Sellers prior to the Closing, and shall be prepared in accordance with the methodology set forth in the IRC. Sellers and Buyer hereby undertake and agree to timely file any information that may be required to be filed pursuant to any treasury regulations promulgated under Section 1060(B) of the IRC. Neither Sellers nor Buyer shall file any tax return or other document or otherwise take any position for tax purposes that is inconsistent with the allocation determined pursuant to this Section 2.7 except as may be adjusted by subsequent agreement following an audit by the Internal Revenue Service or by court decision. Sellers and Buyer shall (i) be bound by the Allocation Statement and (ii) act in accordance with the Allocation Statement in the preparation, filing and audit of any Tax return (including, without limitation filing Form 8594 with its federal income Tax return for the taxable year that includes the Closing Date). Notwithstanding the foregoing, in no event shall the allocation determined pursuant to this Section 2.7 be binding upon Sellers in proceedings in the Bankruptcy Court with respect to any allocation for the distribution of the proceeds of the sale contemplated by this Agreement.

**Section 2.8 Closing.** Subject to the terms and conditions of this Agreement, the sales and purchases of the Purchased Assets, the assignments of the Assumed Contracts and the assumptions of the Assumed Liabilities contemplated hereby shall take place at a closing (the "Closing") to be held at the offices of Walker, Truesdell, Radick & Associates, 380 Lexington Avenue, Suite 1514, New York, New York 10168, or at such other location as the parties hereto shall agree in writing, at 11:00 A.M., as soon as practicable, but in any event on the later to occur of (i) the date on which the conditions to Closing set forth in Article 9 shall have been satisfied or waived and (ii) the first business day following the day that is ten (10) days after the entry of the Sale Order and after the Sale Order has become a Final Order, or at such other time or place as Buyer and Sellers may agree in writing.

(a) Buyer shall deliver to Sellers the Cash Amount in immediately available funds by wire transfer to an account of Sellers with a bank in the United States designated by Sellers, by notice to Buyer, which notice shall be delivered not later than two business days prior to the date of the Closing (the "Closing Date") (or if not so designated, then by certified or official bank check payable in immediately available funds to the order of Sellers in such amount).

(b) Buyer shall deliver to Sellers the Warrant not later than the date of Closing.

(c) Sellers shall deliver to Buyer such deeds, bills of sale, assignments and other instruments of conveyance reasonably requested by Buyer to vest in Buyer all of Sellers' right, title and interest in, to and under the Purchased Assets.

(d) Sellers and Buyer shall enter into an Assignment and Assumption Agreement substantially in the form attached hereto as Exhibit A.

**ARTICLE 3  
REPRESENTATIONS AND WARRANTIES OF SELLERS**

Subject to the entry of the Sale Order, Sellers, by and through the Trustee solely in his capacity as the Trustee and without personal liability, jointly and severally hereby represent and warrant to Buyer as follows:

Section 3.1 Organization and Standing; Authority. Each Seller is a corporation validly existing and in good standing under the laws of its jurisdiction of incorporation and has all corporate powers and all governmental licenses, authorizations, permits, consents and approvals required to enter into this Agreement and the transactions contemplated thereunder. Each Seller has heretofore delivered to Buyer true and complete copies of the certificate of incorporation and bylaws of such Seller as currently in effect. Subject to approval of this Agreement by the Bankruptcy Court, each Seller has all requisite corporate power and authority to enter into this Agreement, to perform its obligations hereunder and to consummate the transactions contemplated hereby. Subject to approval by the Bankruptcy Court, (a) all corporate acts and other proceedings required to be taken by each Seller to authorize the execution, delivery and performance of this Agreement and the consummation of the transactions contemplated hereby have been duly and properly taken and (b) this Agreement has been duly executed and delivered by each Seller and constitutes a legal, valid and binding obligation of each Seller, enforceable against each Seller in accordance with its terms.

Section 3.2 No Conflicts; Consents.

(a) Except as set forth in Schedule 3.2(a) or as excused by the Bankruptcy Code, the execution and delivery of this Agreement by Sellers do not, and the consummation of the transactions contemplated hereby and compliance with the terms hereof will not, conflict with, or result in any violation of or default (with or without notice or lapse of time, or both) under, or give rise to a right of termination, cancellation, modification or acceleration of any obligation under, or loss of a benefit relating to the Purchased Assets under, or result in the creation of any Lien (other than any Permitted Lien) upon any of the Purchased Assets under, any provision of (i) the certificate of incorporation or bylaws of any Seller or other comparable governing instruments of Sellers, as the case may be, or the comparable governing instruments of any subsidiary of Sellers, (ii) assuming the obtaining of all of the Required Consents, any loan or credit agreement, note, bond, mortgage, indenture, lien, lease or any other contract, agreement, instrument, permit, commitment, concession, franchise or license applicable to the Sellers or any of their subsidiaries or their respective properties or assets or the Purchased Assets or (iii) any judgment, injunction, order or decree, or statute, law, ordinance, rule or regulation applicable to Sellers or their assets.



(b) No material consent, approval, grant, concession, agreement, franchise, license, permit, order or authorization of, or registration, declaration or filing with, any Governmental Entity is required to be obtained or made by or with respect to any Seller in connection with the execution, delivery and performance of this Agreement or the consummation of the transactions contemplated hereby, other than (i) compliance with any notices, motions, orders or approvals required by the Bankruptcy Court or the Bankruptcy Code and the rules thereunder, (ii) those set forth on Schedule 3.2(a) and (iii) those that may be required solely by reason of Buyer's participation in the transactions contemplated hereby.

Section 3.3 Sufficiency of and Title to the Purchased Assets. As of the Closing Date, Sellers have good and marketable title to each of the Purchased Assets that is owned by any of the Sellers, and valid leasehold interests in each of the Purchased Assets that is leased by any of the Sellers. The Purchased Assets, taken as a whole, constitute all the properties, assets and rights related to the Intended Business. Each of the Purchased Assets: (i) as of the Closing Date is free and clear of all Liens, except the Permitted Liens; (ii) as of the Closing Date is not subject to any pending actions relating to any such property, except as set forth in Schedule 3.3(a)(ii); (iii) has received all approvals of Governmental Entities (including licenses) required in connection with the ownership or operation thereof and has been operated and maintained in accordance with applicable laws, rules and regulations; and (iv) is not subject to any lease, sublease, license, concession, or other agreement, written or oral, granting to any party or parties the right of use or occupancy of any portion of any property or right of way. As of the Closing, each item of the Purchased Assets is in the working order and state of repair it was in on the date of this Agreement, ordinary wear and tear excepted.

Section 3.4 Required Consents. Schedule 3.4 sets forth each agreement, contract or other instrument binding upon any Seller requiring a consent or other action by any person as a result of the execution, delivery and performance of this Agreement, unless such document can be assumed and assigned without such consent under the Bankruptcy Code, except such consents or actions as would not, individually or in the aggregate, have a material adverse effect on the Purchased Assets and Assumed Liabilities, taken together, or the Intended Business if not received or taken (the "Required Consents").

Section 3.5 Material Contracts. To the Trustee's Knowledge on behalf of Sellers

(a) except as set forth in Schedule 3.5(a), as of the date hereof, Sellers are not a party to or bound by:

(i) any (A) lease for real property or (B) lease for personal property requiring aggregate payments after Closing of \$100,000 or more;

(ii) any agreement for the purchase by Sellers of materials, supplies, goods, services, equipment or other assets that has a term of at least one year or that requires aggregate payments after Closing of \$100,000 or more;

(iii) any agreement for the sale by Sellers of materials, supplies, goods, services, equipment or other assets that has a term of at least one year or that requires aggregate payments after Closing of \$100,000 or more;

(iv) any other agreement that requires aggregate payments after Closing of \$25,000 or more;

(v) any partnership, joint venture or other similar agreement or arrangement;

(vi) any content license or distribution, marketing, agency or other similar agreement;

(vii) any agreement with any investor or affiliate of any Seller other than agreements relating to their investment in any Seller;

(viii) any agreement that limits the freedom of Sellers to compete in any line of business or with any person or in any area or to own, operate, sell, transfer, pledge or otherwise dispose of or encumber any Purchased Asset or which would so limit the freedom of Buyer after the Closing Date;

(ix) any other agreement, commitment, arrangement or plan that is material to the Purchased Assets and the Assumed Liabilities, taken together, or the Intended Business.

(b) except as set forth in Schedule 3.5(b), each agreement listed in Schedule 3.5(a) is a valid and binding agreement of Sellers and is in full force and effect, except as enforceability may be limited by any applicable bankruptcy, reorganization, insolvency or other laws affecting creditors' rights generally or by general principles of equity, regardless of whether such enforceability is considered in equity or law, and none of Sellers or any other party thereto is in default or breach in any material respect under the terms of any such agreement, which would not be cured by the payment of the Cure Amount, and no event or circumstance has occurred that, with notice or lapse of time or both, would constitute any event of default thereunder. True and complete copies of each such agreement have been delivered to Buyer.

(c) The agreements marked with an asterisk on Schedule 3.5(a) represent all of the material agreements of Sellers are or may be advantageous to the Intended Business. The cure amount, if any, for each such agreement is set forth next to such agreement on Schedule 3.5(a).

Section 3.6 Intellectual Property. To the Trustee's Knowledge on behalf of Sellers

(a) Schedule 3.6(a) contains a true and complete list of each trademark (including service marks and logos), corporate name, trade name, domain name, patent, subscriber list, registered copyright and any material third party computer software other than "shrink-wrap and similar widely-available binary code and commercial end-user licenses that are available for less than \$5,000 (including any registrations or applications for registration of any of the foregoing) owned, licensed or used by Sellers as of the date hereof, which schedule indicates whether the right is owned or licensed and by which Seller and, if licensed, the name of the third party licensor (the "Scheduled Intellectual Property"). With respect to the Scheduled Intellectual Property, such schedule also specifies, to the extent applicable, (i) the jurisdictions in which such rights are registered or in which an application for registration has been filed; (ii) the registration or application numbers; and (iii) with respect to the trademarks, the renewal dates.

(b) Other than "shrink-wrap" and similar widely-available binary code and commercial end-user licenses that are available for less than \$5,000, Schedule 3.6(b) sets forth a list of all licenses, sublicenses and other agreements as to which Sellers are a party and pursuant to which any person is authorized to use any Intellectual Property Rights owned, licensed or used by Sellers.

(c) Sellers have good and marketable title to or a valid license to use all Intellectual Property Rights owned, licensed or used by Sellers, free and clear of any Lien. None of such Intellectual Property Rights has been adjudged invalid or unenforceable in whole or part, and all such Intellectual Property Rights are valid and enforceable. Sellers have taken reasonable steps in accordance with normal industry practice to maintain and protect the owned Intellectual Property Rights and their rights in the licensed Intellectual Property Rights, including payment of applicable maintenance fees and filing of applicable statements of use, except as has been agreed upon by the Sellers and Buyer with respect to certain applications outside the United States and Canada. Except as set forth in Schedule 3.6(c), the use by Sellers of the Scheduled Intellectual Property does not infringe, misappropriate or otherwise violate the rights of any other person and, no other person is infringing, misappropriating or otherwise violating any such Intellectual Property Rights.

(d) With respect to pending applications and applications for registration of the Scheduled Intellectual Property, Sellers and their affiliates are not aware of any reason that could reasonably be expected to prevent any such application or application for registration from being granted with coverage substantially equivalent to the latest amended version of the pending

application or application for registration, except as set forth in Schedule 3.6(d). None of the trademarks and applications for trademarks included in the Scheduled Intellectual Property has been the subject of an opposition or cancellation procedure.

(e) Sellers have taken reasonable steps in accordance with normal industry practice to maintain the confidentiality of all confidential Intellectual Property Rights owned, licensed or used by Sellers. None of the Scheduled Intellectual Property, the value of which is contingent upon maintaining the confidentiality thereof, has been disclosed other than (x) to employees, representatives and agents of Sellers all of whom are bound by written confidentiality agreements substantially in the form previously disclosed to Buyer and (y) to third parties bound by written confidentiality agents.

(f) The consummation of the transactions contemplated by this Agreement will not alter, impair or extinguish any Intellectual Property Rights owned, licensed or used by Sellers. Except as set forth in Schedule 3.6(f), there exist no restrictions on the disclosure, use or transfer of any such owned Intellectual Property Rights.

(g) Except as set forth in Schedule 3.6(g), none of Sellers has given an indemnity in connection with any Intellectual Property Rights to any person.

(h) Except as set forth in Schedule 3.6(h), none of Sellers and any of their affiliates has infringed, misappropriated or otherwise violated any Intellectual Property Rights of any third person. Except as set forth in Schedule 3.6(h), there is no material claim, action, suit, investigation or proceeding pending against, or threatened against or affecting, the Intended Business or the Purchased Assets or any present or former officer, director or employee (in their capacity as such) of Sellers (i) based upon, or challenging or seeking to deny or restrict, the rights of Sellers in any of the Intellectual Property Rights owned, licensed or used by Sellers, (ii) alleging that the use of any such Intellectual Property Rights or any services provided or processes used do or may infringe, misappropriate or otherwise violate any Intellectual Property Right of any third party or (iii) alleging that Sellers or any affiliate of Sellers infringed, misappropriated or otherwise violated any Intellectual Property Right of any third party.

**Section 3.7 Litigation.** Schedule 3.7 contains an accurate list of all legal actions, suits and proceedings related to the Intended Business or the Purchased Assets pending as of the date hereof against any Seller. Except as described in Schedule 3.7, there is no action, suit, investigation or proceeding (or any basis therefor) pending against, or to the Trustee's Knowledge on behalf of Sellers, threatened against or affecting, the Intended Business, any Purchased Asset before any court or arbitrator or any governmental body, agency or official which, individually or is the aggregate, could reasonably be expected to be material to the Purchased Assets and Assumed Liabilities, taken together, or the Intended Business, or which in any manner challenges or seeks to prevent, enjoin, alter or materially delay the transactions contemplated by this Agreement.

Section 3.8 Compliance with Laws and Court Orders. Except as set forth in Schedule 3.8, Sellers are not in violation of and have not violated and, to the Trustee's Knowledge on behalf of Sellers, are not under investigation with respect to and have not been threatened to be charged with or given notice of any violation of, any law, rule, regulation, judgment, injunction, order or decree applicable to the Intended Business or the Purchased Assets, except for violations that have not had and could not reasonably be expected to be material to the Purchased Asset and Assumed Liabilities, taken, together, or the Intended Business.

Section 3.9 Brokers and Finders. Except as set forth in Schedule 3.9, there is no investment banker, broker, finder or other intermediary which has been retained by or is authorized to act on behalf of Sellers who might be entitled to any fee or commission in connection with the transactions contemplated by this Agreement.

Section 3.10 Subsidiaries. Napster has no subsidiaries other than Napster Music, Napster Mobile and Napster International, Ltd. Napster International, Ltd. is a shell company and has no assets or liabilities.

Section 3.11 No Warranties. Except as expressly provided herein, neither Sellers nor any other Person makes any express or implied representation or warranty on behalf of Sellers. ALL WARRANTIES, EXPRESS OR IMPLIED, INCLUDING WARRANTIES OF MERCHANTABILITY AND FITNESS FOR A PARTICULAR PURPOSE, ARE EXCLUDED FROM THE SALE AND TRANSFER OF THE PURCHASED ASSETS AND THE ASSUMED LIABILITIES. THE FOREGOING PROVISION DOES NOT AFFECT THE VALIDITY OF THE REPRESENTATIONS AND WARRANTIES PRIOR TO CLOSING, IT BEING THE INTENTION OF EACH OF THE PARTIES (SELLERS, ON THE ONE HAND, AND, BUYER, ON THE OTHER) THAT THE ACCURACY OF THE REPRESENTATIONS AND WARRANTIES IS A CONDITION TO THE OTHER PARTY'S OBLIGATIONS HEREUNDER.

#### ARTICLE 4 REPRESENTATIONS AND WARRANTIES OF BUYER

Buyer represents and warrants to Sellers as follows:

Section 4.1 Organization and Standing; Authority. Buyer is a corporation duly formed, validly existing and in good standing under the laws of the State of Delaware and has all corporate powers and all material governmental licenses, authorizations, permits, consents and approvals required to carry on its business as now conducted. Buyer has all requisite corporate power and authority to enter into this Agreement, to perform its obligations hereunder and to consummate the transactions contemplated hereby to be consummated by Buyer. All corporate acts and other proceedings required to be taken by Buyer to authorize the execution, delivery and performance of this Agreement and the consummation of the transactions contemplated hereby

to be consummated by Buyer have been duly and properly taken. This Agreement has been duly executed and delivered by Buyer and constitutes a legal, valid and binding obligation of Buyer, enforceable against Buyer in accordance with its terms.

Section 4.2 No Conflicts; Consents.

(a) The execution and delivery of this Agreement by Buyer do not, and the consummation of the transactions contemplated hereby and compliance with the terms hereof will not, conflict with, or result in any violation of or default (with or without notice or lapse of time, or both) under, or give rise to a right of termination, cancellation, modification or acceleration of any obligation under, any provision of (i) the certificate of incorporation or bylaws of Buyer or other comparable governing instruments of Buyer, as the case may be, or the comparable governing instruments of any subsidiary of Buyer or (ii) any judgment, injunction, order, decree, statute, law, ordinance, rule or regulation applicable to Buyer or its assets.

(b) No material consent, approval, grant, concession, agreement, franchise, license, permit, order or authorization of, or registration, declaration or filing with, any Governmental Entity is required to be obtained or made by or with respect to Buyer or its Affiliates in connection with the execution, delivery and performance of this Agreement or the consummation of the transactions contemplated hereby, other than (i) compliance with any notices, motions, orders or approvals required by the Bankruptcy Court or the Bankruptcy Code and the rules thereunder and (ii) those that may be required solely by reason of Sellers' participation in the transactions contemplated hereby.

Section 4.3 Availability of Funds. Buyer has cash available sufficient to enable Buyer to purchase the Purchased Assets and otherwise consummate the transactions contemplated by this Agreement in a timely manner.

Section 4.4 Brokers and Finders. Except as set forth in Schedule 4.4, there is no investment banker, broker, finder or other intermediary which has been retained by or is authorized to act on behalf of Buyer who might be entitled to any fee or commission in connection with the transactions contemplated by this Agreement.

Section 4.5 Payments. Neither Buyer, nor any Affiliate of Buyer, nor any officer, director, employee or agent thereof, has, directly or indirectly, paid or delivered, offered to pay or deliver, or agreed to pay or deliver any fee, commission or other sum of money or item of property, however characterized, to any person which is now or was previously an affiliate or insider (as those terms are defined in the Bankruptcy Code) of any Seller.

Section 4.6 No Warranties. Except as expressly provided herein, neither Buyer nor any other Person makes any express or implied representation or warranty on behalf

of Buyer. THE FOREGOING PROVISION DOES NOT AFFECT THE VALIDITY OF THE REPRESENTATIONS AND WARRANTIES PRIOR TO CLOSING, IT BEING THE INTENTION OF EACH OF THE PARTIES (SELLERS, ON THE ONE HAND, AND, BUYER, ON THE OTHER) THAT THE ACCURACY OF THE REPRESENTATIONS AND WARRANTIES IS A CONDITION TO THE OTHER PARTY'S OBLIGATIONS HEREUNDER.

Section 4.7 Actions and Proceedings, etc. There are no (a) outstanding judgments, orders, injunctions or decrees of any Governmental Entity or arbitration tribunal against Buyer or any of its respective Affiliates, (b) lawsuits, actions or proceedings pending or, to the knowledge of Buyer, threatened against Buyer or any of its Affiliates, or (c) investigations by any Governmental Entity which are, to the knowledge of Buyer, pending or threatened against Buyer or any of its Affiliates, and which, in the case of each of clauses (a), (b) and (c), have a material adverse effect on the ability of Buyer to consummate the transactions contemplated hereby to be consummated by Buyer.

## ARTICLE 5 COVENANTS OF SELLERS

Sellers jointly and severally agree that:

Section 5.1 Conduct of the Intended Business. From the date hereof until the Closing Date, subject to the requirements and restrictions of the Bankruptcy Court proceedings and to the fact that the Intended Business conducted by the Sellers is currently not in operation, Sellers shall use their best efforts to preserve the Purchased Assets.

Section 5.2 Access to Information; Assistance.

(a) From the date hereof until the Closing Date, Sellers will (i) give Buyer, its counsel, financial advisors, auditors and other authorized representatives access to the offices, properties, books and records of Sellers relating to the Intended Business or the Purchased Assets, (ii) furnish to Buyer, its counsel, financial advisors, auditors and other authorized representatives such financial and operating data and other information relating to the Intended Business or the Purchased Assets as such Persons may reasonably request, if such access would not constitute a waiver of the attorney client privilege, and (iii) instruct the agents, counsel and financial advisors of Sellers to cooperate with Buyer in its investigation of the Intended Business. In addition, Sellers will ensure that all equipment and machinery containing the Purchased Assets shall remain available to Buyer for ten days after the Closing. Any investigation pursuant to this Section 5.2 shall be conducted in such manner as not to interfere unreasonably with the conduct of the Sellers. No investigation by Buyer or other information received by Buyer shall operate as a waiver or otherwise affect any representation, warranty or agreement given or made by Sellers under this Agreement. Notwithstanding the foregoing, Buyer shall not have access to personnel records of Sellers relating to individual performance or

evaluation records, medical histories or other information which in Sellers' good faith opinion is sensitive or the disclosure of which could subject Sellers to risk of liability. Prior to the Closing Sellers (i) shall use their best efforts to provide demonstrations of technology and (ii) shall provide to Buyer at least 100 man hours of service prior to November 25, 2002, including without limitation, the assistance in backing up or duplicating technology and other data.

(b) After the Closing, the Trustee will hold, and will use his commercially reasonable efforts to cause his respective officers, directors, employees, accountants, counsel, consultants, advisers and agents to hold, in confidence, unless compelled to disclose by judicial or administrative process or by other requirements of law, all confidential documents and information concerning the Intended Business, except to the extent that (i) such information can be shown to have been in the public domain through no fault of Sellers or their Affiliates or (ii) later lawfully acquired on a nonconfidential basis by Sellers or their Affiliates from sources other than those related to their prior ownership of the Purchased Assets or the Intended Business. In addition, the Trustee and Sellers agree to cooperate with Buyer in Buyer's enforcement of nondisclosure agreements with respect to the Purchased Assets transferred to Buyer hereunder, provided that Buyer shall reimburse reasonable costs in connection with such enforcement.

Section 5.3 Notices of Certain Events.

(a) Sellers shall promptly notify Buyer of:

(i) any notice or communication from any Person alleging that the consent of such Person is or may be required in connection with the transactions contemplated by this Agreement;

(ii) any notice or other communication from any Governmental Entity in connection with the transactions contemplated by this Agreement;

(iii) any actions, suits, claims, investigations or proceedings commenced or, to the Trustee's Knowledge on behalf of Sellers, threatened against, relating to or involving or otherwise affecting any Seller or the Purchased Assets or the Assumed Liabilities, that, if pending on the date of this Agreement, would have been required to have been disclosed pursuant to Section 3.7, that relate to the consummation of the transactions contemplated by this Agreement; and

(iv) the damage or destruction by fire or other casualty of any material Purchased Asset or any material part thereof or if any material Purchased Asset or any material part thereof becomes the subject of any proceeding or, to the Trustee's Knowledge on behalf of Sellers, threatened proceeding, for the taking thereof or any part



thereof or of any right relating thereto by condemnation, eminent domain or other similar governmental action.

(b) Sellers shall promptly notify Buyer of, and furnish Buyer any information which Buyer may reasonably request with respect to, the occurrence to the Trustee's Knowledge on behalf of Sellers of any event or condition or the existence to the Trustee's Knowledge on behalf of Sellers of any fact that would cause any of the conditions to Buyer's obligations to consummate the purchase and sale of the Purchased Assets not to be fulfilled. If between the date hereof and the Closing Date, any of the matters referenced in Section 5.3(a)(iv) shall have occurred, then Sellers, at their option, shall either repair any damage or casualty at its expense or deliver to Buyer on the Closing Date any insurance proceeds (including but not limited to condemnation insurance proceeds), or rights to receive insurance proceeds, with respect thereto or the Purchase Price shall be reduced by such amount.

**Section 5.4 Bankruptcy Court Approval.**

(a) On November 5, 2002 Sellers filed a motion seeking the approval of sale procedures (the "Sale Procedures Motion"). Sellers shall pursue the Sale Procedures Motion and seek entry of the order therein in the form attached hereto as Exhibit D (the "Sale Procedures Order") on the grounds that, inter alia, the New DIP Loan provided by Buyer has preserved the value of Sellers' assets and the negotiation of the Agreement by Buyer and its offer for the Purchased Assets will maximize the value to be obtained from the Purchased Assets.

(b) As soon as practicable after execution of this Agreement, Sellers shall file with the Bankruptcy Court an application or motion (the "Sale Motion") (reasonably satisfactory in form and substance to Buyer) on shortened time seeking:

(i) approval of all transactions contemplated under the Agreement on the terms contained herein and the performance of Sellers of their obligations under the Agreement, including without limitation the sale, transfer, assignment, conveyance and delivery of the Purchased Assets to Buyer (or its successors or permitted assigns) free and clear of all Liens (except for the Permitted Liens);

(ii) approval of the Sellers' assumption and assignment of all of the Assumed Contracts to Buyer;

(iii) approval of the Breakup Fee on the grounds that, inter alia, the New DIP Loan provided by Buyer has preserved the value of the Sellers' assets and the negotiation of the Agreement by Buyer and its offer for the Purchased Assets will maximize the value to be obtained from the Purchased Assets; and

(iv) entry of the Sale Order.

(c) Provided that Buyer has provided a list of the Assumed Contracts pursuant to Section 6.6, not less than twelve (12) days prior to the hearing on the Sale Motion or on any such date agreed in writing by Buyer, Sellers shall provide written notice to each of the non-Seller parties to each Assumed Contract of their intent to assume and assign such Assumed Contracts (including any Cure Amounts) to Buyer.

(d) Sellers further agree to promptly take such actions as are reasonably requested by Buyer to assist in obtaining Bankruptcy Court approval of the Agreement and entry of the Sale Order, including without limitation furnishing affidavits, declarations or other documents or information for filing with the Bankruptcy Court.

**Section 5.5 Permits.** Prior to the Closing Date, each Seller shall use its commercially reasonable efforts (i) to identify all material permits necessary to transfer the Purchased Assets on the Closing Date and necessary to operate the Intended Business from and after the Closing Date and (ii) to obtain consents to the transfer of such material permits which are transferable to Buyer at or prior to Closing. Prior to and after the Closing, each Seller shall cooperate with Buyer with respect to the transfer of all material permits.

**Section 5.6 Cure Amounts.** Unless the Bankruptcy Court orders otherwise, promptly after the Closing Sellers shall pay all amounts, as determined by the Bankruptcy Court, required under Section 365 of the Bankruptcy Code to cure any and all defaults under the Assumed Contracts and to compensate the parties to the Assumed Contracts for any actual pecuniary losses resulting from such defaults (the "Cure Amount"), which amounts shall be advanced by Buyer to Sellers for such payment.

**Section 5.7 Name Changes.** Promptly, but in no event later than 30 days, after the Closing, Sellers jointly and severally agree (a) to change the name of each Seller to some other name not using the word "Napster" and (b) after the Closing, until papers are duly filed with the applicable Secretaries of State to effect such name changes, not to use the name of any Seller in any way for the purpose of selling or marketing any product or service or otherwise in any manner which does or might compete with Buyer or, in any other way which, in the Buyer's reasonable judgment, could be detrimental to Buyer's enjoyment of the rights and goodwill it sought when it paid for and acquired the assets of Sellers, except as expressly agreed by Buyer in its sole discretion.

## ARTICLE 6 COVENANTS OF BUYER

Buyer agrees that:

**Section 6.1 Confidentiality.** Prior to the Closing Date and after any termination of this Agreement, Buyer and its Affiliates will hold, and will use their commercially reasonable efforts to cause their respective officers, directors, employees, accountants, counsel, consultants, advisors and agents to hold, in confidence, unless legally compelled to disclose under subpoena or order of any court or regulatory authority of competent jurisdiction and is advised by counsel to do so, any confidential documents and information concerning the Intended Business and the Purchased Assets Sellers furnished to Buyer or its Affiliates in connection with the transactions contemplated by this Agreement, except to the extent that such information can be shown to have been (i) previously known on a nonconfidential basis by Buyer or its Affiliates, (ii) in the public domain through no fault of Buyer or its Affiliates or (iii) later lawfully acquired by Buyer from sources other than Sellers; provided that Buyer may disclose such information to its officers, directors, employees, accountants, counsel, consultants, advisors and agents in connection with the transactions contemplated by this Agreement so long as such persons are informed by Buyer of the confidential nature of such information and are directed by Buyer to treat such information confidentially. The obligation of Buyer and its affiliates to hold any such information in confidence shall be satisfied if they utilize safeguards and a standard of care at least as stringent as the Sellers to preserve the confidentiality of their own confidential information. If this Agreement is terminated, the confidential information that is written, except for the portion that may be found in documents prepared by Buyer and its Affiliates, shall be returned to the Sellers immediately upon request, and no copies or reproductions shall be retained by Buyer and its Affiliates. That portion of the confidential information that is found in documents prepared by Buyer and its Affiliates, the confidential information that is oral and the confidential information that is not so requested or returned will be held by Buyer and its Affiliates and kept confidential pursuant to the terms of this Section 6.1 or destroyed. The complete and final return and destruction of the confidential information shall be confirmed by Buyer in writing to the Sellers. The delivery or destruction of the confidential information shall not relieve Buyer and its Affiliates of their obligations under this Section 6.1. After the Closing, Buyer shall continue to be subject to the confidentiality provisions of this Section 6.1 to the extent that Buyer has received from Sellers any information which relates to an Excluded Asset or Excluded Liability.

**Section 6.2 No Additional Representations.** Buyer acknowledges and agrees that none of Sellers nor any other Person has made any representation or warranty, expressed or implied, with respect to (i) the transactions contemplated hereby, (ii) Sellers or Sellers' assets, liabilities or Intended Business, or (iii) the accuracy or completeness of any information regarding any Seller furnished or made available to Buyer and its representatives, except as expressly set forth in this Agreement.

**Section 6.3 Supplemental Disclosure.** Buyer shall promptly after the occurrence thereof notify Sellers of, and furnish Sellers any information it may reasonably request with respect to, the occurrence to the knowledge of Buyer of any event or condition or the existence to Buyer's knowledge of any fact that would cause any of the conditions to Sellers' obligation to consummate the purchase and sale of the Purchased Assets not to be fulfilled.

Section 6.4 Assignment to Affiliate. Prior to the Closing, upon not less than two (2) business days' notice to Sellers, Buyer may assign to its Affiliate all of its rights under this Agreement and cause its Affiliate to assume all of the liabilities and obligations of Buyer under this Agreement. Any such assignment and assumption shall not relieve Buyer of its liabilities and obligations under this Agreement.

Section 6.5 Buyer's Cooperation. Buyer shall use its commercially reasonable efforts to cooperate in providing such information and evidence as is necessary to obtain the orders described in Section 5.4.

Section 6.6 Delivery of List of Assumed Contracts. Buyer shall deliver to Sellers on or before November 15, 2002 a list of contracts Buyer has designated as the Assumed Contracts, provided that Buyer may remove contracts from that list at any time prior to the Closing.

#### ARTICLE 7 COVENANTS OF ALL PARTIES

Buyer and Sellers agree that:

Section 7.1 Commercially Reasonable Efforts; Further Assurances.

(a) Subject to the terms and conditions of this Agreement, Buyer and Sellers will each use their commercially reasonable efforts to take, or cause to be taken, all actions and to do, or cause to be done, all things necessary or desirable under applicable laws and regulations to consummate the transactions contemplated by this Agreement. Sellers and Buyer each agree to execute and deliver such other documents, certificates, agreements and other writings and to take such other actions as may be necessary or desirable in order to consummate or implement expeditiously the transactions contemplated by this Agreement and to vest in Buyer good and marketable title to the Purchased Assets.

(b) Sellers hereby constitute and appoint, effective as of the Closing Date, Buyer and its successors and assigns as the true and lawful attorney of Sellers with full power of substitution in the name of Buyer or in the name of each Seller, but for the benefit of Buyer (i) to collect for the account of Buyer any items of Purchased Assets and (ii) to institute and prosecute all proceedings which Buyer may in its sole discretion deem proper in order to assert or enforce any right, title or interest in, to or under the Purchased Assets, and to defend or compromise any and all actions, suits or proceedings in respect of the Purchased Assets. Buyer shall be entitled to retain for its own account any amounts collected pursuant to the foregoing powers, including any amounts payable as interest in respect thereof.

(c) Subject to the terms and conditions of this Agreement, Buyer and Sellers will each use their commercially reasonable efforts to take all action and to do all things necessary, proper, or advisable to consummate and make effective the transactions contemplated by this Agreement (including without limitation Sellers' use of their commercially reasonable efforts to file any and all necessary documents to transfer or assign the domain names with the applicable registrar of domain names) and to obtain approval and entry of the Sale Order.

Section 7.2 Certain Filings. Sellers and Buyer shall cooperate with one another (a) in determining whether any action by or in respect of, or filing with, any Governmental Entity is required, or any actions, consents, approvals or waivers are required to be obtained from parties to any material contracts, in connection with the consummation of the transactions contemplated by this Agreement and (b) in taking such actions or making any such filings, furnishing information required in connection therewith and seeking timely to obtain any such actions, consents, approvals or waivers.

Section 7.3 Public Announcements. The parties agree to consult with each other before issuing any press release or making any public statement with respect to this Agreement or the transactions contemplated hereby and, except as may be required by applicable law or any listing agreement with any national securities exchange, will not issue any such press release or make any such public statement prior to such consultation.

Section 7.4 Post-Closing Access to Books and Records. After the Closing Date, the parties agree that they will each cooperate with and make available to the other party, during normal business hours, all Books and Records, information (without substantial disruption of employment) retained and remaining in existence after the Closing Date which are necessary or useful in connection with any inquiry relating to Taxes or any audit, investigation or dispute, any litigation or investigation or any other matter requiring any such Books and Records, information or employees for any reasonable business purpose. The party requesting any such Books and Records, information shall bear all of the out-of-pocket costs and expenses (including, without limitation, attorneys' fees, but excluding reimbursement for general overhead, salaries and employee benefits) reasonably incurred in connection with providing such Books and Records, information or employees. Sellers may require certain financial information relating to the Intended Business for periods prior to the Closing Date for the purpose of filing federal, state, local and foreign Tax Returns and other governmental reports, and Buyer agrees to furnish such information to Sellers at Sellers' request and expense.

## ARTICLE 8 TAX MATTERS

Section 8.1 Tax Matters. Sellers hereby represent and warrant to Buyer that:

(a) Sellers have timely paid all Taxes, and all interest and penalties due thereon, payable by it for the Pre-Closing Tax Period which will have been required to be paid on or prior to the Closing Date, the non-payment of which would result in a Lien on any Purchased Asset, would otherwise adversely affect the Intended Business or would result in Buyer becoming liable or responsible therefor.

(b) Sellers have established, in accordance with generally accepted accounting principles applied on a basis consistent with that of preceding periods, adequate reserves for the payment of, and will timely pay all Tax liabilities, assessments, interest and penalties which arise from or with respect to the Purchased Assets or the operation of the Intended Business and are incurred in or attributable to the Pre-Closing Tax Period, the non-payment of which would result in a Lien on any Purchased Asset, would otherwise adversely affect the Intended Business or would result in Buyer becoming liable therefor.

(c) At the Closing, Sellers shall provide a schedule reflecting accrued and unpaid real and personal property Taxes on all Purchased Assets using a ratable daily accrual method. Sellers will furnish Buyer with an analysis of this amount itemized by property and jurisdiction.

**Section 8.2 Tax Cooperation: Allocation of Taxes.**

(a) Buyer and Sellers agree to furnish or cause to be furnished to each other, upon request, as promptly as practicable, such information and assistance relating to the Purchased Assets and the Intended Business as is reasonably necessary for the filing of all Tax returns, and making of any election related to Taxes, the preparation for any audit by any taxing authority, and the prosecution or defense of any claim, suit or proceeding relating to any Tax return. Sellers and Buyer shall cooperate with each other in the conduct of any audit or other proceeding related to Taxes involving the Intended Business and each shall execute and deliver such documents as are necessary to carry out the intent of this paragraph (a) of Section 8.2.

(b) All Apportioned Obligations shall be apportioned between Sellers and Buyer as of the Closing Date based on the number of days of such taxable period included in the Pre-Closing Tax Period and the number of days of such taxable period included in the Post-Closing Tax Period. Sellers shall be liable for the proportionate amount of such taxes that is attributable to the Pre-Closing Tax Period, and Buyer shall be liable for the proportionate amount of such taxes that is attributable to the Post-Closing Tax Period.

Within 90 days after the Closing, Sellers and Buyer shall each present a statement to the other setting forth the amount of reimbursement to which each is entitled under this Section 8.2(b) together with such supporting evidence as is reasonably necessary to calculate the proration amount. The proration amount shall be paid by the party owing it to the other within 10 days after delivery of such statement. Thereafter, Sellers shall notify Buyer upon receipt of any bill for real or personal property taxes relating to the Purchased Assets, part or all of which is attributable to the Post-Closing Tax Period, and shall promptly deliver such bill to Buyer, who

shall pay the same to the appropriate taxing authority, *provided* that if such bill covers the Pre-Closing Tax Period, Sellers shall also remit prior to the due date of assessment to Buyer, payment for the proportionate amount of such bill that is attributable to the Pre-Closing Tax Period. If either Sellers or Buyer shall thereafter make a payment for which it is entitled to reimbursement under this Section 8.2(b), the other party shall make such reimbursement promptly but in no event later than 30 days after the presentation of a statement setting forth the amount of reimbursement to which the presenting party is entitled along with such supporting evidence as is reasonably necessary to calculate the amount of reimbursement. Any payment required under this Section and not made within 10 days of delivery of the statement shall bear interest at the rate per annum determined, from time to time, under the provisions of Section 6621(a)(2) of the IRC for each day until paid.

(c) Any transfer, documentary, sales, use or other Taxes assessed upon or with respect to the transfer of the Purchased Assets to Buyer and any recording or filing fees with respect thereto shall be paid by Seller.

**Section 8.3 Transfer Taxes.** In accordance with section 1146(c) of the Bankruptcy Code, the making or delivery of any instrument of transfer, including the filing of any deed or other document of transfer to evidence, effectuate or perfect the rights, transfer and interest contemplated by this Agreement, shall be in contemplation of a plan or plans of reorganization to be confirmed in the Bankruptcy Case, and as such shall be free and clear of any and all transfer tax, stamp tax or similar taxes. The instruments transferring the Assets to Buyer shall contain the following endorsement:

"Because this [instrument] has been authorized pursuant to Order of the United States Bankruptcy Court for the District of Delaware, in contemplation of a plan of reorganization of the Grantor, it is exempt from transfer taxes, stamp taxes or similar taxes pursuant to 11 U.S.C. §1146(c)."

In the event real estate transfer taxes are required to be paid in order to record the deeds to be delivered to Buyer in accordance herewith, or in the event any such taxes are assessed at any time thereafter, such real estate transfer taxes incurred as a result of the transactions contemplated hereby shall be paid by Sellers. In the event sales, use or other transfer taxes are assessed at Closing or at any time thereafter on the transfer of any other Assets, such taxes incurred as a result of the transactions contemplated hereby shall be paid by Sellers.

**Section 8.4 Tax Payments Made by Buyer.** Any payments made by Buyer for which it is entitled to reimbursement under Section 8.2(b) and Section 8.3 of this Agreement shall constitute allowed superpriority administrative expense claims against the Sellers estates with priority over any and all administrative expenses of the kind specified in Bankruptcy Code Sections 503(b) and 507(b).

**ARTICLE 9  
CONDITIONS TO CLOSING**

**Section 9.1 Conditions to Buyer's Obligations.** The obligation of Buyer to consummate the Closing is subject to the satisfaction (or waiver by Buyer, without further notice to parties in interest or approval by the Bankruptcy Court) of the following conditions:

(a) The representations and warranties of Sellers made in this Agreement shall be true and correct in all material respects as of the Closing Date as though made as of such time, except to the extent such representations and warranties expressly relate to an earlier date (in which case such representations and warranties shall be true and correct in all material respects on and as of such earlier date). Sellers shall have performed or complied in all material respects with all obligations and covenants required by this Agreement to be performed or complied with by Sellers by the Closing Date. Sellers shall have delivered to Buyer a certificate dated the Closing Date confirming the foregoing.

(b) No provision of any applicable statute, rule, regulation, executive order, decree, temporary restraining order, judgment, preliminary or permanent injunction or other order enacted, entered, promulgated, enforced or issued by any Governmental Entity shall be in effect that (x) prevents the sale and purchase of the Purchased Assets or any of the other transactions contemplated by this Agreement, (y) would adversely affect or interfere with the operation of the Intended Business previously conducted after the Closing, or (z) would require Buyer or any of its Affiliates to sell or otherwise dispose of, hold separate or otherwise divest itself of, or operate in any particular manner, any of the Purchased Assets or any of the assets, properties or business of Buyer or any of its Affiliates.

(c) There shall not be pending or threatened by any Governmental Entity any suit, action or proceeding, (i) challenging or seeking to restrain, prohibit, alter or materially delay the sale and purchase of the Purchased Assets or any of the other transactions contemplated by this Agreement, or seeking to obtain from Buyer or any of its Affiliates in connection with the sale and purchase of the Purchased Assets any material damages or (ii) seeking to prohibit Buyer or any of its Affiliates from effectively controlling or operating a material portion of the Intended Business or the Purchased Assets.

(d) Sellers shall have received all Required Consents as set forth in Schedule 3.4.

(e) The Bankruptcy Court shall have entered the Sale Order and the Sale Order shall not have been modified, amended or stayed, except as agreed to by Buyer, and shall have become a Final Order.



(f) The Intellectual Property Rights shall be transferred to the Buyer, and upon Closing shall be free and clear of all interests of any kind or nature whatsoever including without limitation any interest of John Fanning in the Assigned Intellectual Property.

(g) All documentation that is necessary to transfer and assign to Buyer the Intellectual Property Rights or to perfect and record such transfer and assignment shall have been delivered to Buyer.

Section 9.2 Conditions to Obligation of Sellers. The obligation of Sellers to consummate the Closing is subject to the satisfaction (or waiver by Sellers, without further notice to parties in interest or approval by the Bankruptcy Court) of the following conditions:

(a) The representations and warranties of Buyer made in this Agreement shall be true and correct as of the Closing Date as though made as of such time, except to the extent such representations and warranties expressly relate to an earlier date (in which case such representations and warranties shall be true and correct in all material respects on and as of such earlier date). Buyer shall have performed or complied in all material respects with all obligations and covenants required by this Agreement to be performed or complied with by Buyer by the Closing Date. Buyer shall have delivered to Sellers a certificate dated the Closing Date and signed by the chief financial officer of Buyer confirming the foregoing and certifying the resolutions of Buyer's Board of Directors approving the transactions contemplated hereunder.

(b) No provision of any applicable statute, rule, regulation, executive order, decree, temporary restraining order, judgment, preliminary or permanent injunction or other order enacted, entered, promulgated, enforced or issued by any Governmental Entity shall be in effect that prevents the sale and purchase of the Purchased Assets or any of the transactions contemplated by this Agreement.

(c) There shall not be pending or threatened by any Governmental Entity any suit, action or proceeding, (i) challenging or seeking to restrain, prohibit, alter or materially delay the sale and purchase of the Purchased Assets or any of the other transactions contemplated by this Agreement or seeking to obtain from Sellers in connection with the sale and purchase of the Purchased Assets any material damages.

(d) The Bankruptcy Court shall have entered the Sale Order and the Sale Order shall not have been modified, amended or stayed, except as agreed to by Sellers, and shall have become a Final Order.

Section 9.3 Frustration of Conditions. Neither Buyer nor Sellers may rely on the failure of any condition set forth in Section 9.1 or 9.2, respectively, to be satisfied if such failure was caused by such party's failure to act in good faith or to use its reasonable efforts to cause the Closing to occur, as provided in this Agreement.

**ARTICLE 10  
SURVIVAL**

**Section 10.1 Survival.** The covenants, agreements, representations and warranties of Sellers and Buyer hereto contained in this Agreement or in any certificate or other writing delivered pursuant hereto or in connection herewith shall not survive the Closing except for the covenants and agreements contained herein which contemplate or specifically provide for performance after the Closing Date.

**ARTICLE 11  
TERMINATION**

**Section 11.1 Grounds for Termination.** This Agreement may be terminated at any time prior to the Closing:

(a) by mutual written agreement of Sellers and Buyer;

(b) by either Sellers or Buyer if the Closing shall not have been consummated on or before December 31, 2002;

(c) by either Sellers or Buyer if there shall be any law or regulation that makes the consummation of the transactions contemplated hereby illegal or otherwise prohibited or if consummation of the transactions contemplated hereby would violate any nonappealable final order, decree or judgment of any court or governmental body having competent jurisdiction;

(d) by Buyer if (i) there is the entry of an order, which has not been withdrawn, dismissed or reversed dismissing the Bankruptcy Case or converting the Bankruptcy Case to a case under Chapter 7 of the Bankruptcy Code, (ii) Sellers file a motion, application or other petition to effect or consent to the foregoing or (iii) there is an Event of Default under the New DIP Loan;

(e) by Buyer if the Sale Order shall not have been entered on or prior to December 6, 2002;

(f) if the Bankruptcy Court shall have approved the sale of any or all of the Purchased Assets to a Person other than Buyer; and

(g) by Buyer if the Sales Procedure Order shall not have been entered on or prior to November 20, 2002.

The party desiring to terminate this Agreement pursuant to clauses (b), (c), (d), (e), (f), or (g) shall give notice of such termination to the other parties.

Section 11.2 Effect of Termination. If this Agreement is terminated as permitted by Section 11.1, such termination shall be without liability of any party (or any stockholder, director, officer, employee, agent, consultant or representative of such party) to the other party to this Agreement; *provided* that if such termination shall result from the willful failure of any party to fulfill a condition to the performance of the obligations of another party, failure to perform a covenant of this Agreement or breach by any party to this Agreement of any representation or warranty or agreement contained herein, such failing or breaching party shall be fully liable for any and all losses incurred or suffered by the other party as a result of such failure or breach; and *provided further* that if this Agreement is terminated pursuant to Section 11.1(f) as a result of the Bankruptcy Court's approval of the sale of any or all of the Purchased Assets to another Person, Sellers shall jointly and severally pay Buyer the Breakup Fee. The provisions of Sections 5.2, 6.1, 11.2, 13.3, 13.4 and 13.5 shall survive any termination hereof pursuant to Section 11.1.

## ARTICLE 12 MISCELLANEOUS

Section 12.1 Notices. All notices or other communications required or permitted to be given hereunder shall be in writing and shall be delivered by hand, sent by confirmed fax or sent, postage prepaid, by registered, certified or express mail or reputable overnight courier service and shall be deemed given when so delivered by hand, confirmed faxed or if mailed, three days after mailing (one business day in the case of express mail or overnight courier service), as follows (or to such other address or telecopy number as the applicable party shall have notified the other parties in writing in accordance with this Section):

if to Buyer, to:

Roxio, Inc.  
455 El Camino Real  
Santa Clara, CA 95050  
Attention: William Growney, Esq.  
Fax: (408) 367-2913

with a copy to:

O'Melvcny & Myers LLP  
610 Newport Center Drive, 17<sup>th</sup> Floor  
Newport Beach, CA 92660  
Attention: Suzzanne Uhland, Esq.  
Fax: (949) 823-6994

if to Sellers, to:

---

Hobart G. Truesdell, as Chapter 11 Trustee  
Walker, Truesdell, Radick & Associates  
380 Lexington Avenue, Suite 1514  
New York, NY 10168  
Fax: (212) 687-0994

with a copy to:

Morrison & Foerster LLP  
1290 Avenue of the Americas  
New York, New York 10104-0050  
Attention: John R. Hampill  
Fax: (212) 468-7900

and

Official Committee of Unsecured Creditors

Greenberg Traurig, LLP  
200 Park Avenue  
New York, New York 10166  
Attention: Rick B. Antonoff, Esq.  
Fax: (212) 801-6400

Section 12.2 Amendments and Waivers.

(a) Any provision of this Agreement may be amended or waived prior to the Closing Date if, but only if, such amendment or waiver is in writing and is signed, in the case of an amendment, by each party to this Agreement, or in the case of a waiver, by the party against whom the waiver is to be effective.

(b) No failure or delay by any party in exercising any right, power or privilege hereunder shall operate as a waiver thereof nor shall any single or partial exercise thereof preclude any other or further exercise thereof or the exercise of any other right, power or privilege. The rights and remedies herein provided shall be cumulative and not exclusive of any rights or remedies provided by law.

Section 12.3 Fees and Expenses.

(a) Except as otherwise provided herein, all costs and expenses incurred in connection with this Agreement shall be paid by the party incurring such cost or expense.

(b) Sellers shall pay (i) all fees or commissions of any investment banker, broker or finder retained by it that has acted for Sellers in connection with this Agreement or the transactions contemplated hereby and (ii) the Breakup Fee if this Agreement is terminated pursuant to Section 11.1(f) as contemplated by Section 11.2.

(c) Buyer shall pay all fees or commissions of any investment banker, broker or finder retained by it that has acted for Buyer in connection with this Agreement or the transactions contemplated hereby.

Section 12.4 Successors and Assigns. The provisions of this Agreement shall be binding upon and inure to the benefit of the parties hereto and their respective successors and assigns; *provided* that no party may assign, delegate or otherwise transfer any of its rights or obligations under this Agreement without the consent of the other party hereto except that, pursuant to Section 6.4, Buyer may transfer or assign, in whole or from time to time in part, to its Affiliate, the right to purchase all or a portion of the Purchased Assets, but no such transfer or assignment will relieve Buyer of its obligations hereunder.

Section 12.5 Governing Law. This Agreement shall be governed by and construed in accordance with the law of the State of California, without regard to the conflicts of law rules of such state.

Section 12.6 Counterparts; Effectiveness. This Agreement may be signed in any number of counterparts, each of which shall be an original, with the same effect as if the signatures thereto and hereto were upon the same instrument. This Agreement shall become effective when each party hereto shall have received a counterpart hereof signed by the other parties hereto.

Section 12.7 Entire Agreement; Third Party Beneficiaries. This Agreement, and the documents referred to herein and therein constitute the entire agreement between the parties with respect to the subject matter hereof and supersede all prior agreements and understandings, both written and oral, between the parties with respect to such subject matter. No representation, inducement, promise, understanding, condition or warranty not set forth herein has been made or relied upon by any party hereto. Neither this Agreement nor any provision hereof is intended to confer upon any Person other than the parties hereto any rights or remedies hereunder.

Section 12.8 Captions. The captions herein are included for convenience of reference only and shall be ignored in the construction or interpretation hereof.

Section 12.9 Severability. If any provision of this Agreement (or any portion thereof) or the application of any such provision (or any portion thereof) to any Person or circumstance shall be held invalid, illegal or unenforceable in any respect by a court of

---

competent jurisdiction, such invalidity, illegality or unenforceability shall not affect any other provision hereof (or the remaining portion thereof) or the application of such provision to any other Persons or circumstances.

**Section 12.10 Consent to Jurisdiction.** Each party hereto irrevocably submits to the non-exclusive jurisdiction of the United States Bankruptcy Court for the District of Delaware for the purposes of any action, suit or other proceeding arising out of or related to this Agreement, or any transaction contemplated hereby but for no other purpose. Each party hereto irrevocably and unconditionally waives any objection to the laying of venue of any action, suit or proceeding arising out of this Agreement or the transactions contemplated hereby in the Bankruptcy Court, and hereby further irrevocably and unconditionally waives and agrees not to plead or claim in any such court that any such action, suit or proceeding brought in any such court has been brought in an inconvenient forum.

**Section 12.11 WAIVER OF JURY TRIAL.** EACH OF THE PARTIES HERETO HEREBY IRREVOCABLY WAIVES ANY AND ALL RIGHT TO TRIAL BY JURY IN ANY LEGAL PROCEEDING ARISING OUT OF OR RELATED TO THIS AGREEMENT, ANY OTHER DOCUMENT REFERRED TO HEREIN OR THE TRANSACTIONS CONTEMPLATED HEREBY OR THEREBY.

IN WITNESS WHEREOF, the parties hereto have caused this Agreement to be duly executed by their respective authorized officers as of the day and year first above written.

BUYER: ROXIO, INC.

By: Thomas J. Shea  
Thomas J. Shea  
Chief Operating Officer

OK LEGAL  
WJG

SELLERS:

By: \_\_\_\_\_  
Hobart G. Truesdell  
Chapter 11 Trustee for Napster, Inc., Napster  
Music Company, Inc. and Napster Mobile  
Company, Inc.

IN WITNESS WHEREOF, the parties hereto have caused this Agreement to be duly executed by their respective authorized officers as of the day and year first above written.

**BUYER: ROXIO, INC.**

By: \_\_\_\_\_  
Thomas J. Shea  
Chief Operating Officer

**SELLERS:**

By: Hobart G. Truesdell  
Hobart G. Truesdell  
Chapter 11 Trustee for Napster, Inc., Napster  
Music Company, Inc. and Napster Mobile  
Company, Inc.

75074518X

3-1

Nov. 14 2002 11:09PM PT

FAX NO. : 2036981370

FROM : P006



**Exhibit A**  
**Assignment and Assumption Agreement**

NBI-578505 7

---

**Exhibit B**  
**Warrant Agreement**

ND1:578505.7

## WARRANT AGREEMENT

THIS WARRANT AGREEMENT (this "Agreement") dated as of the 27<sup>th</sup> day of November, 2002, by and between Roxio Inc., a Delaware Corporation (the "Company"), and NAPSTER, INC., a Delaware corporation (the "Warrantholder").

### RECITALS

WHEREAS, the Warrantholder is a debtor in a proceeding under Chapter 11 of the Bankruptcy Code pending in the United States Bankruptcy Court for the District of Delaware (the "Bankruptcy Court");

WHEREAS, the Company and Warrantholder are parties to that certain Asset Purchase Agreement, dated as of the date hereof (the "Purchase Agreement"), pursuant to which the Company is purchasing certain assets of the Warrantholder; and

WHEREAS, in order to induce the Warrantholder to enter into the Purchase Agreement, the Company has granted to the Warrantholder, effective as of the date hereof (the "Grant Date"), a warrant to purchase 100,000 shares of the Company's Common Stock, par value \$0.001 per share (the "Common Stock"), subject to and upon the terms and conditions set forth herein;

NOW, THEREFORE, in consideration of the mutual promises and covenants made herein and the mutual benefits to be derived herefrom and for other good and valuable consideration, the receipt of which is hereby acknowledged, the parties agree as follows:

1. **Grant of Warrant.** This Agreement evidences the Company's grant to the Warrantholder of the right and option to purchase, subject to and on the terms and conditions set forth herein, 100,000 shares of the Company's Common Stock (the "Shares"), at \$3.124 per share (the "Warrant"), exercisable from time to time as provided in Section 2 hereof prior to the close of business on the day before the third anniversary of the Grant Date (the "Expiration Date"), unless earlier terminated pursuant to Section 5(c) hereof.
2. **Exercisability of Warrant.** The Warrant is exercisable, in whole or in part, at any time from the Grant Date until the Expiration Date, unless earlier terminated pursuant to Section 5 hereof. If, at any time of exercise, the Warrantholder does not purchase all of the Shares to which the Warrantholder is entitled under this Agreement, the Warrantholder has the right cumulatively thereafter to purchase any such Shares not so purchased and such right shall continue until the Expiration Date (unless earlier terminated pursuant to Section 5(c) hereof). The Warrant shall only be exercisable in respect of whole Shares, and fractional Share interests shall be disregarded.
3. **Method of Exercise of Warrant.**
  - (a) The Warrant shall be exercisable by the delivery to the Secretary of the Company by the Warrantholder of a written notice accompanied by (i) delivery of an executed Exercise Agreement in the form attached hereto as Exhibit A, (ii) payment of the full purchase price of the Shares to be purchased upon such exercise, and (iii) payment in full of any tax withholding obligation under federal, state or local law. Payment shall be made in the form of a

certified or cashier's check payable to the order of the Company. Certificates for Shares so purchased, together with any other securities or property to which the Warrantholder is entitled upon such exercise, shall be delivered to the Warrantholder by the Company at the Company's expense promptly after the Warrant has been so exercised. Each such certificate shall be in such denominations of Common Stock as may be requested by the Warrantholder and shall be registered in the name of the Warrantholder.

- (b) In lieu of exercising the Warrant for cash, the Warrantholder may elect to receive shares equal to the value (as determined below) of the Warrant (or the portion thereof being canceled) by surrender of the Warrant at the principal office of the Company, together with an executed Exercise Agreement in the form attached hereto as Exhibit A, in which event the Company shall issue to the Warrantholder a number of Shares computed using the following formula:

$$X = \frac{Y(A-B)}{A}$$

Where:

X = the number of shares to be issued to the Warrantholder.

Y = the number of Shares purchasable under the Warrant or, if only a portion of the Warrant is being exercised, the portion of the Warrant being exercised (at the date of such calculation).

A = the Fair Market Value (as defined below) of one share of Common Stock.

B = the Exercise Price (as adjusted to the date of such calculation).

"Fair Market Value" shall be (i) if the Common Stock of the Company is publicly traded on a national securities exchange or The Nasdaq Stock Market, the average of the closing prices of the Common Stock on such exchange or market over the five (5) trading days ending immediately prior to the date on which the Company receives the applicable Exercise Agreement, (ii) if the Common Stock is actively traded over-the-counter, the average of the closing bid prices over the five (5) day period ending immediately prior to the date on which the Company receives the applicable Exercise Agreement and (iii) if there is no active public market, the value determined in good faith by the Board of Directors of the Company.

4. Warrant Not Transferable.

- (a) The Warrant may be exercised only by, and shares issuable pursuant to the Warrant shall be issued only to, the Warrantholder except with respect to clause (b) below.
- (b) No right or benefit under the Warrant shall be transferrable by the Warrantholder or shall be subject in any manner to anticipation, alienation, sale, transfer, assignment, pledge, encumbrance or charge and any such attempted action shall be void; however, it is contemplated by this Agreement that the Warrantholder may transfer the Warrant (in whole, but not in part) and

the rights and obligations thereunder to a single successor to the Warrantholder under a plan confirmed by order of the Bankruptcy Court, provided that the single successor is an "accredited investor" as defined in Regulation D promulgated under the Securities Act (as defined below) and such transfer is exempt from registration under, and complies with, all applicable federal and state securities laws, or, after consultation with the Company's counsel, the Company concludes that such transfer is otherwise exempt from registration under, and complies with, all applicable federal and state securities laws and such transfer would otherwise be exempt under, and comply with, all applicable federal and state securities laws (including but not limited to Section 25102(f) of the California Corporate Securities Law) if such transferee were the original purchaser hereunder.

5. **Adjustment and Termination upon Certain Events.** The Exercise Price and the number of Shares purchasable upon exercise of the Warrant shall be subject to adjustment from time to time upon the occurrence of certain events described in this Section 5. Upon each adjustment of the Exercise Price, the Warrantholder shall thereafter be entitled to purchase, at the Exercise Price resulting from such adjustment, the number of Shares obtained by multiplying the Exercise Price in effect immediately prior to such adjustment by the number of Shares purchasable pursuant hereto immediately prior to such adjustment, and dividing the product thereof by the Exercise Price resulting from the adjustment.
- (a) If the Company shall at any time prior to the expiration of the Warrant subdivide its Common Stock, by stock split or otherwise, or combine its Common Stock, or issue additional shares of its Common Stock as a dividend with respect to any shares of its Common Stock, the number of Shares issuable on the exercise of the Warrant shall be forthwith proportionately increased in the case of a subdivision or stock dividend, or proportionately decreased in the case of a combination. Appropriate adjustments shall also be made to the Exercise Price as provided herein, but the aggregate purchase price payable for the total number of Shares purchasable under the Warrant (as adjusted) shall remain the same. Any adjustment under this Section 5(a) shall become effective at the close of business on the date of the subdivision or combination becomes effective or as of the record date of such dividend, or in the event that no record date is fixed, upon making of such dividend.
- (b) In case of (i) any reclassification, capital reorganization, or change or conversion in the Common Stock of the Company (other than as a result of a subdivision, combination, or stock dividend provided for in Section 5(a) above) or (ii) any dividend or distribution of Common Stock (other than as a result of a subdivision, combination or stock dividend provided for in Section 5(a) above), or other securities which are at any time directly or indirectly convertible into or exchangeable for any other securities of the Company or another issuer, cash, evidence of indebtedness of the Company or another issuer or any rights or options to subscribe for, purchase or otherwise acquire any of the foregoing by way of dividend or other distribution, then, as a condition of such reclassification, reorganization, or change, lawful provision shall be made, and duly executed documents evidencing the same from the Company or its successor shall be delivered to the Warrantholder, so that the

Warrantholder shall have the right at any time prior to the expiration of the Warrant to purchase, at a total price equal to that payable upon the exercise of the Warrant, the kind and amount of shares of stock and other securities and property receivable in connection with such reclassification, reorganization or change by a holder of the same number of shares of Common Stock as were purchasable by the Warrantholder immediately prior to such reclassification, reorganization or change. In any such case appropriate provisions shall be made with respect to the rights and interest of the Warrantholder so that the provisions hereof shall thereafter be applicable with respect to any Shares or other securities and property deliverable upon exercise hereof, and appropriate adjustments shall be made to the Exercise Price as provided herein; provided further the aggregate purchase price shall remain the same.

- (c) Notwithstanding anything else contained herein to the contrary, the Warrant to the extent not previously exercised shall terminate upon (i) the liquidation or dissolution of the Company, (ii) the closing of a sale of all or substantially all of the Company's assets, or (iii) the closing of the acquisition of the Company by another entity by means of a merger, consolidation or other transaction or series of related transactions, resulting in the exchange of the outstanding shares of the Company's capital stock such that stockholders of the Company prior to such transaction own, directly or indirectly, less than 50% of the voting power of the surviving entity.
- (d) Promptly after any adjustment to the number or class of Shares subject to the Warrant and the Exercise Price, the Company shall give written notice thereof to the Warrantholder, setting forth in reasonable detail and certifying the calculation of such adjustment. In case of any of the events described in Section 5(c) above, the Company shall give reasonable prior written notice thereof to the Warrantholder, which shall be at least 20 days prior to each such event, setting forth in reasonable detail a description of any such event including, among other things, the date on which the event is scheduled to occur; provided, however, if a record date is set by the Company with respect to any such event, the Company will provide the Warrantholder reasonable prior written notice of such record date, which shall be at least 20 days prior to such record date. Any and all notices shall be delivered in accordance with Section 8 below.

6. **Compliance; Application of Securities Laws.** This Agreement and the offer, issuance and delivery of the Warrant and the Shares are subject to compliance with all applicable federal and state laws, rules and regulations (including but not limited to state and federal securities laws and federal margin requirements) and to such approvals by any listing, regulatory or governmental authority as may, in the opinion of counsel for the Company, be necessary or advisable in connection therewith.

7. **Investment Representations.** By execution of this Agreement, the Warrantholder makes the representations set forth below to the Company and acknowledges that the Company's reliance on federal and state securities law exemptions from registration and qualification is predicated, in part, on such representations:

- (a) **No Intent to Sell.** The Warrantholder represents that it is acquiring the Warrant and the Shares solely for its own account, for investment purposes

only, and not with a view to or an intent to sell, or to offer for resale in connection with any unregistered distribution of all or any portion of the Warrant or the Shares within the meaning of the Securities Act of 1933, as amended (the "Securities Act") or applicable state securities laws, except as contemplated under Section 4(b) of this Agreement.

- (b) **Accredited Investor.** The Warrantholder represents that it is an "accredited investor" as defined in Regulation D promulgated under the Securities Act.
- (c) **No Reliance on Company.** In evaluating the merits and risks of an investment in the Warrant and the Shares, the Warrantholder represents that it has and will rely upon the advice of its own legal counsel, tax advisors, and/or investment advisors. Accordingly, the Warrantholder hereby represents and warrants that it has reviewed the legal, accounting, tax and other economic aspects of the Warrantholder's investment with the Warrantholder's own advisors and is not relying on the Company for any legal, tax, accounting or other economic considerations involved in the Warrantholder's investment in the Company.
- (d) **Restrictions on Warrant and Shares.** The Warrantholder represents that it understands that the Warrant and the Shares are and will be characterized as "restricted securities" under the federal securities laws since the Warrant and the Shares are being acquired from the Company in a transaction not involving a public offering and that under such laws and applicable regulations such securities may be resold without registration under the Securities Act only in certain limited circumstances. The Warrantholder agrees not to make any disposition of the Warrant or the Shares, except in compliance with all applicable federal and state securities laws and unless and until: (a) there is then in effect a registration statement under the Securities Act covering such proposed disposition and such disposition is made in accordance with such registration statement; or (b) such disposition is made in accordance with Rule 144 under the Securities Act; or (c) the Warrantholder notifies the Company of the proposed disposition and furnishes the Company with a statement of the circumstances surrounding the proposed disposition, and, if requested by the Company, the Warrantholder furnishes the Company with an opinion of counsel acceptable to the Company's counsel, that such disposition will not require registration under the Securities Act and will be in compliance with all applicable state securities laws.
- (e) **Additional Restrictions.** The Warrantholder represents that it has read and understands the restrictions and limitations imposed on the Warrant and the Shares in this Agreement.
- (f) **No Company Representations.** The Warrantholder represents that at no time was an oral representation made to it relating to the purchase of the Warrant or the Shares and that it was not presented with or solicited by any promotional meeting or material relating to the Warrant or the Shares.
- (g) **Share Certificate Legend.** The Warrantholder represents that it understands and acknowledges that any certificate evidencing the Shares (or evidencing any other securities issued with respect thereto pursuant to any stock split,

stock dividend or other form of reorganization or recapitalization) when issued shall bear, in addition to any other legends which may be required by applicable state securities laws, the following legend:

**"OWNERSHIP OF THIS CERTIFICATE AND THE SHARES EVIDENCED BY THIS CERTIFICATE AND ANY INTEREST THEREIN ARE SUBJECT TO RESTRICTIONS ON TRANSFER UNDER APPLICABLE LAW AND UNDER AN AGREEMENT WITH THE COMPANY, INCLUDING RESTRICTIONS ON SALE, ASSIGNMENT, TRANSFER, PLEDGE OR OTHER DISPOSITION, A COPY OF WHICH IS AVAILABLE FOR REVIEW AT THE OFFICE OF THE SECRETARY OF THE COMPANY."**

**"THE SECURITIES REPRESENTED HEREBY HAVE NOT BEEN REGISTERED OR QUALIFIED UNDER THE SECURITIES ACT OF 1933, AS AMENDED ("ACT"), NOR HAVE THEY BEEN REGISTERED OR QUALIFIED UNDER THE SECURITIES LAWS OF ANY STATE. NO TRANSFER OF SUCH SECURITIES WILL BE PERMITTED UNLESS A REGISTRATION STATEMENT UNDER THE ACT IS IN EFFECT AS TO SUCH TRANSFER, THE TRANSFER IS MADE IN ACCORDANCE WITH RULE 144 UNDER THE ACT, OR IN THE OPINION OF COUNSEL TO THE CORPORATION, REGISTRATION UNDER THE ACT IS UNNECESSARY IN ORDER FOR SUCH TRANSFER TO COMPLY WITH THE ACT AND WITH APPLICABLE STATE SECURITIES LAWS."**

8. **Shares Duly Authorized; Securities and Exchange Commission Filings.**
- (a) The Company covenants and agrees that all Shares which may be issued upon the exercise of rights represented by the Warrant will, when issued and paid for in accordance with the terms of this Agreement, be duly authorized, validly issued, fully paid and non-assessable shares of Common Stock. The Company further covenants and agrees that, at all times during which the Warrant may be exercised, the Company will have authorized and reserved, for the purpose of issue upon exercise hereof, a sufficient number of shares of authorized but unissued Common Stock or other securities and property, when and as required to provide for the exercise of the rights represented by the Warrant.
  - (b) As of the date of this Agreement, the Company has timely filed all required periodic reports with the Securities and Exchange Commission since its legal separation from Adaptec in May, 2001.
9. **Notices.** Any notice to be given under the terms of this Agreement shall be in writing and addressed to the Company at its principal executive office, to the attention of the Chief Executive Officer, and to the Warrantholder at the address given beneath the Warrantholder's signature hereto, or at such other address as either party may thereafter designate in writing to the other. All such notices shall be delivered personally, by overnight delivery service, or by U.S. certified or registered mail, postage prepaid, return-receipt requested.



10. **Further Assurances.** Each of the parties hereto shall use its reasonable and diligent best efforts to execute such further documents and other papers and perform such further acts as may be reasonably required or desirable to carry out the provisions hereof and the transactions contemplated herein.
11. **Modifications, Amendments and Waivers.** This Agreement may not be amended, modified or altered except by a written instrument executed by both parties hereto in the same manner in which this Agreement has been executed.
12. **Entire Agreement.** This Agreement is intended to embody the final, complete and exclusive agreement among the parties with respect to the Warrant and the purchase of the Shares, is intended to supersede all prior agreements, understandings and representations written or oral, with respect thereto, and may not be contradicted by evidence of any such prior or contemporaneous agreement, understanding or representation, whether written or oral.
13. **Governing Law and Venue.** This Agreement is to be governed by and construed in accordance with the laws of the State of California applicable to contracts made and to be performed wholly within such state, and without regard to the conflicts of laws principles thereof. Each party hereby agrees that any state or federal courts sitting in Santa Clara County, California shall have in personam jurisdiction over it and consents to service of process in any manner authorized by law.
14. **Binding Effect; Assignment.** This Agreement and the rights, covenants, conditions and obligations of the respective parties hereto and any instrument or agreement executed pursuant hereto shall be binding upon the parties and their respective successors, assigns and legal representatives. Except as provided for under Section 4(b) of this Agreement, neither this Agreement nor the underlying Warrant shall be assigned by the Warrantholder without the prior written consent of the Company, which consent may be withheld in the Company's sole and absolute discretion.
15. **Counterparts.** This Agreement may be executed simultaneously in any number of counterparts, each of which shall be deemed an original but all of which together shall constitute one and the same instrument. This Agreement may be executed by facsimile signatures.
16. **Section Headings.** The section headings of this Agreement are for convenience of reference only and shall not be deemed to alter or affect any provision hereof.
17. **Representation by Counsel.** Each party to this Agreement has been represented by counsel in connection with this Agreement and the transactions contemplated by this Agreement. Accordingly, any rule of law, including but not limited to, Section 1654 of the California Civil Code, or any legal decision that would require interpretation of any claimed ambiguities in this Agreement against the party that drafted it has no application and is expressly waived.
18. **Survival.** The representations, warranties and agreements shall survive acceptance of this Agreement by the Company, exercise of the Warrant and payment of the purchase price for the Shares by the Warrantholder and the issuance of the Shares to the Warrantholder.

19. **Severability.** Every provision of this Agreement is intended to be severable. If any term or provision hereof is illegal or invalid for any reason whatsoever, then such illegality or invalidity shall not affect the validity of the remainder of the Agreement.
  
20. **Attorneys' Fees.** In any action at law or in equity to enforce any provisions or rights under this Agreement, the unsuccessful party to such litigation, as determined by the court in a final judgment, decree or decision, shall pay the successful party all costs, expenses and reasonable attorneys' fees, as set by the court and not by a jury, incurred by the successful party (including, without limitation, costs, expenses and fees on any appeal).

[Signature Page Follows]

IN WITNESS WHEREOF, the parties have duly executed this Agreement as of the date first written above.

**ROXIO, INC.**  
a Delaware corporation

By: William F. Crowley, Jr.  
Name: William F. Crowley, Jr.  
Title: Secretary

**WARRANTHOLDER**

By: Hobart G. Truesdell  
Name: Hobart G. Truesdell  
Title: Chapter II Trustee for Napster, Inc.;  
Napster Music Company, Inc.; and  
Address: Napster Mobile Company, Inc.

Walker, Truesdell, Rudick & Assoc.  
380 Lexington Ave, Suite 1514  
New York, N.Y. 10168

EXHIBIT A

EXERCISE AGREEMENT

THIS EXERCISE AGREEMENT (this "Agreement") dated as of the \_\_\_\_ day of \_\_\_\_\_, \_\_\_\_\_, by and between Roxio, Inc., a Delaware corporation (the "Company"), and \_\_\_\_\_ (the "Purchaser").

RECITALS

WHEREAS, the Company has granted to the Purchaser a Warrant (the "Warrant") to purchase 100,000 shares of common stock of the Company and in connection therewith, the Company and the Purchaser entered into that certain Warrant Agreement dated as of November \_\_\_\_, 2002 (the "Warrant Agreement") of which this Agreement is a part and incorporated therein; and

WHEREAS, the Purchaser desires to exercise the Warrant and purchase from the Company and the Company wishes to issue and sell to the Purchaser \_\_\_\_\_ shares of its common stock, par value \$0.001 per share (the "Common Stock"), to be sold at a price of \$ \_\_\_\_\_ per share, in accordance with and subject to the terms and conditions set forth in this Agreement.

NOW, THEREFORE, in consideration of the above premises and the representations, warranties, covenants and agreements contained in this Agreement, and for other good and valuable consideration, the receipt of which is hereby acknowledged, the parties hereto agree as follows:

1. **Purchase and Sale of Common Stock.** The Company shall deliver to the Purchaser a stock certificate representing the shares of Common Stock against delivery to the Company by the Purchaser of the purchase price in the sum of \$ \_\_\_\_\_ (which represents the product of the \$ \_\_\_\_\_ price per share and the number of shares listed above, the "Purchase Price"), except if the Purchaser is exercising the Warrant pursuant to Section 3(b) of the Warrant Agreement, in which case the Purchaser shall so indicate by marking the space provided below.

\_\_\_\_\_ Exercise Pursuant to Section 3(b) of the Warrant Agreement

2. **Investment Representations.** The Purchaser acknowledges that the shares of Common Stock are not being registered under the Securities Act of 1933, as amended (the "Securities Act"). The Purchaser hereby affirms as made as of the date hereof the representations, covenants and agreements made in Section 7 of the Warrant Agreement.
3. **Miscellaneous.** This Agreement shall be governed by and construed and enforced in accordance with the laws of the state of California. This Agreement and the Warrant Agreement together constitute the entire agreement and supersede all prior understandings and agreements, written or oral, of the parties hereto with respect to the subject matter hereof. This Agreement may be amended by mutual agreement of the parties. Such amendment must be in writing and signed by the Company and the

---

Purchaser. The Company may, however, unilaterally waive any provision hereof in writing to the extent such waiver does not adversely affect the interests of the Purchaser hereunder, but no such waiver shall operate as or be construed to be a subsequent waiver of the same provision or a waiver of any other provision hereof.

[Signature Page Follows]

**IN WITNESS WHEREOF**, the parties have duly executed this Agreement as of the date first written above.

**ROXIO, INC.**

By: \_\_\_\_\_  
Name: \_\_\_\_\_  
Title: \_\_\_\_\_

**WARRANTHOLDER**

By: \_\_\_\_\_  
Name: \_\_\_\_\_  
Title: \_\_\_\_\_

---

**Exhibit C**  
**Sale Order**

NB1:578505 7

IN THE UNITED STATES BANKRUPTCY COURT  
FOR THE DISTRICT OF DELAWARE

IN RE:	)	Chapter 11
	)	
NAPSTER, INC.,	)	Jointly Administered
a Delaware corporation, et al.,	)	Case Nos. 02-11573 (PJW)
	)	
Debtors.	)	Hearing Date: November 27, 2002 @ 11:00 a.m.
	)	Related Pleading _____

**ORDER UNDER 11 U.S.C. §§ 105(a), 363, 365 AND 1146(c), AND FED. R. BANKR. P. 2002, 6004, 6006, AND 9014 (A) APPROVING ASSET PURCHASE AGREEMENT; (B) AUTHORIZING THE SALE OF SUBSTANTIALLY ALL OF DEBTORS' ASSETS, (C) AUTHORIZING ASSUMPTION AND ASSIGNMENT OF CERTAIN EXECUTORY CONTRACTS, AND (D) GRANTING OTHER RELATED RELIEF**

This matter having come before the Court on the motion dated November 15, 2002 (the "Motion"),<sup>1</sup> of Hobart G. Truesdell, in his capacity as the Chapter 11 Trustee (the "Trustee") for the above-captioned debtors (the "Debtors") for, inter alia, entry of an order under 11 U.S.C. §§ 105(a), 363, 365, and 1146(c) and Fed. R. Bankr. P. 2002, 6004, 6006, and 9014 (the "Sale Order") authorizing (i) the Trustee's sale (the "Sale") of substantially all of the Debtors' assets (the "Assets"), free and clear of any mortgage, lien, pledge, charge, easement, option, right of first refusal, right of first offer, right of first use or occupancy, indenture, deed of trust, right of way, tenancy, restriction on the use of real property, restriction upon voting or transfer, encroachment, license to a third party, lease to a third party, security agreement, security interest, encumbrance or other adverse claim, restriction or limitation of any kind in respect of such property or asset or irregularities in title thereto (collectively, "Interests"), except for the Assumed Liabilities and Permitted Liens (collectively, the "Surviving Obligations"), pursuant to and as described in the Asset Purchase Agreement, dated as of

<sup>1</sup> Unless otherwise defined, capitalized terms used herein shall have the meaning ascribed to them in the Motion or the Asset Purchase Agreement, as the case may be.



---

November 15, 2002 (the "Asset Purchase Agreement"), between the Debtors and Roxio, Inc., as buyer (the "Buyer"), and the assumption by the Buyer of certain liabilities of the Debtors (the "Assumed Liabilities"), pursuant to and as described in the Asset Purchase Agreement, and (ii) the Debtors' assumption and assignment to the Buyer of certain executory contracts (the "Assumed Contracts"), pursuant to and as described in the Asset Purchase Agreement, free and clear of all interests except the Surviving Obligations; and the Court having entered an order on November 15, 2002 (the "Procedures Order") (i) authorizing the Trustee to proceed with a sale (the "Sale") of the assets of the Debtors, (ii) establishing procedures (the "Procedures") to be employed in connection with the Sale including approval of a break-up fee, (iii) approving form and notice of the Sale, (iv) setting dates for a sale hearing and deadlines for the filing of objections to the Sale and objections to the assumption and assignment of executory contracts and unexpired leases and to cure payments proposed to be paid in connection with the Sale, and (v) granting related relief; and a hearing on the Motion having been held on November 27, 2002 (the "Sale Hearing") at which time interested parties were offered an opportunity to be heard with respect to the Motion; and the Court having reviewed and considered (i) the Motion, (ii) objections thereto, if any, (iii) the arguments of counsel made, and the evidence proffered or adduced, at the Sale Hearing; and it appearing that the relief requested in the Motion is in the best interests of the Debtors, their estates and creditors and other parties in interest; and upon the record of the Sale Hearing and these cases; and after due deliberation thereon; and good cause appearing therefor, it is hereby

FOUND AND DETERMINED THAT:<sup>2</sup>

A. The court has jurisdiction over this Motion pursuant to 28 U.S.C. §§ 157 and 1334, and this matter is a core proceeding pursuant to 28 U.S.C. § 157(b)(2)(A). Venue of these cases and the Motion in this district is proper under 28 U.S.C. §§ 1408 and 1409.

B. The statutory predicates for the relief sought in the Motion are sections 105(a), 363(b), (f), (k), (m), and (n), 365, and 1146(c) of the United States Bankruptcy Code, 11 U.S.C. §§ 101-1330, as amended (the "Bankruptcy Code") and Fed. R. Bankr. P. 2002, 6004, 6006, 9014 and 9019.

C. Proper timely, adequate and sufficient notice of the Motion, the Sale Hearing, the Sale, and the assumption and assignment of the Assumed Contracts has been provided in accordance with 11 U.S.C. §§ 102(1), 363 and 365 and Fed. R. Bankr. P. 2002, 6004, 9014 and 9019 and in compliance with the Procedures Order, and such notice was good and sufficient, and appropriate under the particular circumstances, and no other or further notice of the Motion, the Sale Hearing, the Sale or the assumption and assignment of the Assumed Contracts is or shall be required.

D. As demonstrated by (i) the testimony and other evidence proffered or adduced at the Sale Hearing and (ii) the representations of counsel made on the record at the Sale Hearing, the Debtors have complied with the Procedures Order.

E. The Trustee on behalf of the Debtors and each Debtor (i) have full corporate power and authority to execute the Asset Purchase Agreement and all other documents contemplated thereby and the consummation of the transactions contemplated by the Asset

---

<sup>2</sup> Findings of fact shall be construed as conclusions of law and conclusions of law shall be construed as findings of fact when appropriate. See Fed. R. Bankr. P. 7052.

Purchase Agreement by the Trustee and the Debtors have been duly and validly authorized by all necessary corporate action of each of the Debtors, (ii) have all of the corporate power and authority necessary to consummate the transactions contemplated by the Asset Purchase Agreement and (iii) have taken all corporate action necessary to authorize and approve the Asset Purchase Agreement and the consummation by the Trustee and such Debtors of the transactions contemplated thereby; and no consents or approvals, other than those expressly provided for in the Asset Purchase Agreement, are required for the Trustee or the Debtors to consummate such transactions.

F. Approval of the Asset Purchase Agreement and consummation of the transactions contemplated by the Asset Purchase Agreement at this time are in the best interests of the Debtors, their creditors, their estates, and other parties in interest.

G. The Debtors have demonstrated both (i) good, sufficient, and sound business purpose and justification and (ii) compelling circumstances for the Sale pursuant to 11 U.S.C. § 363(b) prior to, and outside of, a plan of reorganization.

H. A reasonable opportunity to object or be heard with respect to the Motion and the relief requested therein has been afforded to all interested persons and entities, including: (i) the Office of the United States Trustee, (ii) counsel for Buyer, (iii) counsel for the Debtors, (iv) counsel for the Committee, (v) counsel to Bertelsmann AG; (vi) all entities who have filed and served requests for notices in these cases, (vii) all other parties-in-interest, (viii) all appropriate state and local taxing authorities which may be affected by the proposed sale, (ix) all entities that have previously submitted written bids to acquire the Debtors' assets, and (x) all non-Debtor parties to Assumed Contracts.

I. The Asset Purchase Agreement was negotiated, proposed and entered into by the parties without collusion, in good faith, and from arm's-length bargaining positions. The Buyer is a good faith purchaser under 11 U.S.C. § 363(m) and, as such, is entitled to all of the protections afforded thereby. The Buyer will be acting in good faith within the meaning of 11 U.S.C. § 363(m) in closing the transactions contemplated by the Asset Purchase Agreement at all times after the entry of this Sale Order. Neither the Trustee nor the Buyer have engaged in any conduct that would cause or permit the Asset Purchase Agreement to be avoided under 11 U.S.C. § 363(n).

J. The consideration provided by the Buyer for the Assets pursuant to the Asset Purchase Agreement (i) is fair and reasonable, (ii) is the highest and best offer for the Assets, (iii) will provide a greater recovery for the Debtors' creditors than would be provided by any other practical available alternative, and (iv) constitutes reasonably equivalent value and fair consideration under the Bankruptcy Code and under the laws of the United States, any state, territory, possession, or the District of Columbia.

K. The Sale must be approved and consummated promptly in order to preserve the value of the Assets.

L. The transfer of the Assets to the Buyer will be a legal, valid, and effective transfer of the Assets, and will vest the Buyer with all right, title, and interest of the Debtors to the Assets free and clear of all interests, including any interests (A) that purport to give to any party a right or option to effect any forfeiture, modification, right of first refusal, or termination of the Debtors' or the Buyer's interest in the Assets, or any similar rights, or (B) relating to taxes or any other liabilities arising under or out of, in connection with, or in any way relating to, the Assets,

the Debtors or their operations or activities prior to the Closing Date, other than the Surviving Obligations.

M. The Buyer would not have entered into the Asset Purchase Agreement and would not consummate the transactions contemplated thereby, thus adversely affecting the Debtors, their estates, and their creditors, if the sale of the Assets to the Buyer and the assignment of the Assumed Contracts and Assumed Liabilities to the Buyer were not free and clear of all Interests of any kind or nature whatsoever (other than the Surviving Obligations), or if the Buyer would, or in the future could, be liable for any of the Interests, including, without limitation, the Excluded Liabilities.

N. The Trustee may sell the Assets free and clear of all Interests of any kind or nature whatsoever because, in each case, one or more of the standards set forth in 11 U.S.C. § 363(f)(1)-(5) has been satisfied. Those (i) holders of Interests and (ii) non-Debtor parties to Assumed Contracts who did not object, or who withdrew their objections, to the Sale or the Motion are deemed to have consented pursuant to 11 U.S.C. § 363(f)(2). Those holders of Interests are adequately protected by having their Interests, if any, attach to the cash proceeds of the Sale ultimately attributable to the property against or in which they claim an Interest.

O. The (i) transfer of the Assets to the Buyer and (ii) assumption and assignment to the Buyer of the Assumed Contracts and Assumed Liabilities will not subject the Buyer to any liability whatsoever with respect to the Assets, the Debtors or their operations or activities prior to the Closing Date or by reason of such transfer under the laws of the United States, any state, territory, or possession thereof, or the District of Columbia, based, in whole or in part, directly or indirectly, on any theory of law or equity, including, without limitation, any theory of successor or transferee liability.

P. The sale of the Assets to the Buyer is a prerequisite to the Trustee's ability to confirm a plan or plans under 11 U.S.C. § 1129 and to consummate such plan or plans. The Sale is a sale in contemplation of a plan and, accordingly, a transfer pursuant to 11 U.S.C. § 1146(c), which shall not be taxed under any law imposing a stamp tax or similar tax.

Q. The Trustee demonstrated that it is an exercise of his sound business judgment to assume and assign the Assumed Contracts to the Buyer in connection with the consummation of the Sale, and the assumption and assignment of the Assumed Contracts is in the best interests of the Debtors, their estates, and their creditors. The Assumed Contracts being assigned to, and the liabilities being assumed by, the Buyer are an integral part of the Assets being purchased by the Buyer and, accordingly, such assumption and assignment of Assumed Contracts and liabilities are reasonable, enhance the value of the Debtors' estates, and do not constitute unfair discrimination.

R. The Trustee will cause the Debtors to have (i) cured, or provided adequate assurance of cure, of any default existing prior to the date hereof under any of the Assumed Contracts, within the meaning of 11 U.S.C. § 365(b)(1)(A), and (ii) compensated, or provided adequate assurance of compensation, to any party for any actual pecuniary loss to such party resulting from a default prior to the date hereof under any of the Assumed Contracts, within the meaning of 11 U.S.C. § 365(b)(1)(B), and to the extent applicable adequate assurance of future performance of and under the Assumed Contracts within the meaning of 11 U.S.C. § 365(b)(1)(C) has been provided.

NOW THEREFORE, IT IS HEREBY ORDERED, ADJUDGED, AND DECREED

THAT:

General Provisions

1. The Motion is granted, as further described herein.
2. All objections to the Motion or the relief requested therein that have not been withdrawn, waived, or settled, and all reservations of rights included therein, are hereby overruled on the merits.

Approval of the Asset Purchase Agreement

3. The Asset Purchase Agreement, and all of the terms and conditions thereof, is hereby approved.
4. Pursuant to 11 U.S.C. § 363(b), the Trustee on behalf of the Debtors and the Debtors are authorized and directed to consummate the Sale, pursuant to and in accordance with the terms and conditions of the Asset Purchase Agreement.
5. The Trustee is authorized and directed to execute and deliver, and empowered to perform under, consummate and implement, the Asset Purchase Agreement, together with all additional instruments and documents that may be reasonably necessary or desirable to implement the Asset Purchase Agreement, and to take all further actions as may be requested by the Buyer for the purpose of assigning, transferring, granting, conveying and conferring to the Buyer or reducing to possession, the Assets, or as may be necessary or appropriate to the performance of the obligations as contemplated by the Asset Purchase Agreement.

Transfer of Assets

6. Pursuant to 11 U.S.C. §§ 105(a) and 363(f), the Assets shall be transferred to the Buyer, and upon consummation of the Asset Purchase Agreement (the "Closing") shall be, free

and clear of all Interests of any kind or nature whatsoever, including without limitation any alleged Interest of any kind or nature whatsoever asserted by John W. Fanning, other than the Surviving Obligations, with all such Interests of any kind or nature whatsoever to attach to the net proceeds of the Sale in the order of their priority, with the same validity, force and effect which they now have as against the Assets, subject to any claims and defenses the Debtors may possess with respect thereto.

7. Except as otherwise specifically provided by the Asset Purchase Agreement or this Sale Order, all persons and entities, including, but not limited to, all debt security holders, equity security holders, governmental, tax, and regulatory authorities, lenders, trade and other creditors, holding Interests of any kind or nature whatsoever against or in the Debtors or the Assets (whether legal or equitable, secured or unsecured, matured or unmatured, contingent or non-contingent, senior or subordinated), arising under or out of, in connection with, or in any way relating to, the Assets, the Debtors or their operations or activities prior to the date of the Closing (the "Closing Date"), or the transfer of the Assets to the Buyer, hereby are forever barred, estopped, and permanently enjoined from asserting against the Buyer, its successors or assigns, its property, or the Assets, such persons' or entities' Interests.

8. The transfer of the Assets to the Buyer pursuant to the Asset Purchase Agreement constitutes a legal, valid, and effective transfer of the Assets, and shall vest the Buyer with all right, title, and interest of the Debtors in and to the Assets free and clear of all Interests of any kind or nature whatsoever, other than the Surviving Obligations, provided that, notwithstanding the foregoing, to the extent any of the Assets include CD-rom and MP3 files that contain or include copyrighted material or content or include other copyrighted material or content subject to use restrictions, Buyer shall take possession of and store such Assets but shall not use such



copyrighted material or content subject to use restrictions without the consent of the applicable parties.

**Assumption and Assignment to the Buyer  
of Assumed Contracts and Assumed Liabilities**

9. Pursuant to 11 U.S.C. §§ 105(a) and 365, and subject to and conditioned upon the Closing of the Sale, the Debtors' assumption and assignment to the Buyer, and the Buyer's assumption on the terms set forth in the Asset Purchase Agreement, of the Assumed Contracts and Assumed Liabilities is hereby approved, and the requirements of 11 U.S.C. § 365(b)(1) with respect thereto are hereby deemed satisfied.

10. The Trustee is hereby authorized and directed in accordance with 11 U.S.C. §§ 105(a) and 365 to (a) assume and assign to the Buyer, effective upon the Closing of the Sale, the Assumed Contracts and Assumed Liabilities free and clear of all Interests of any kind or nature whatsoever, other than the Surviving Obligations, and (b) execute and deliver to the Buyer such documents or other instruments as may be necessary to assign and transfer the Assumed Contracts and Assumed Liabilities to the Buyer.

11. The Assumed Contracts and Assumed Liabilities shall be transferred to, and remain in full force and effect for the benefit of, the Buyer in accordance with their respective terms, notwithstanding any provision in any such Assumed Contract or Assumed Liability (including those of the type described in sections 365(b)(2) and (f) of the Bankruptcy Code) that prohibits, restricts, or conditions such assignment or transfer and, pursuant to 11 U.S.C. § 365(k), the Debtors shall be relieved from any further liability with respect to the Assumed Contracts and Assumed Liabilities after such assignment to and assumption by the Buyer.

12. All defaults or other obligations of the Debtors under the Assumed Contracts and Assumed Liabilities arising or accruing prior to the date of this Sale Order (without giving effect

to any acceleration clauses or any default provisions of the kind specified in section 365(b)(2) of the Bankruptcy Code) shall be cured as set forth in the Asset Purchase Agreement at the Closing of the Sale or as soon thereafter as practicable, and the Buyer shall have no liability or obligation arising or accruing prior to the date of the Closing of the Sale, except as otherwise expressly provided in the Asset Purchase Agreement.

13. Each non-Debtor party to an Assumed Contract or Assumed Liability hereby is forever barred, estopped, and permanently enjoined from asserting against the Debtors or the Buyer, or the property of either of them, any default existing as of the date of the Sale Hearing; or, against the Buyer, any counterclaim, defense, setoff or any other claim asserted or assertable against the Debtors.

14. The failure of the Debtors or the Buyer to enforce at any time one or more terms or conditions of any Assumed Contract shall not be a waiver of such terms or conditions, or of the Debtors' and Buyer's rights to enforce every term and condition of the Assumed Contracts.

Additional Provisions

15. The consideration provided by the Buyer for the Assets under the Asset Purchase Agreement shall be deemed to constitute reasonably equivalent value and fair consideration under the Bankruptcy Code and under the laws of the United States, any state, territory, possession, or the District of Columbia.

16. The consideration provided by the Buyer for the Assets under the Asset Purchase Agreement is fair and reasonable and may not be avoided under section 363(n) of the Bankruptcy Code.

17. On the Closing Date of the Sale, each of the Debtors' creditors is authorized and directed to execute such documents and take all other actions as may be necessary to release its Interests in the Assets, if any, as such Interests may have been recorded or may otherwise exist.

18. This Sale Order (a) shall be effective as a determination that, on the Closing Date, all Interests of any kind or nature whatsoever existing as to the Debtors or the Assets prior to the Closing (other than the Surviving Obligations) have been unconditionally released, discharged and terminated, and that the conveyances described herein have been effected, and (b) shall be binding upon and shall govern the acts of all entities, including, without limitation, all filing agents, filing officers, title agents, title companies, recorders of mortgages, recorders of deeds, registrars of deeds, administrative agencies, governmental departments, secretaries of state, federal, state, and local officials, registrars of internet domain names and all other persons and entities who may be required by operation of law, the duties of their office, or contract, to accept, file, register or otherwise record or release any documents or instruments, or who may be required to report or insure any title or state of title in or to any of the Assets.

19. Each and every federal, state, and local governmental agency or department, registrar of internet domain names and any other person or entity is hereby directed to accept any and all documents and instruments necessary and appropriate to consummate the transactions contemplated by the Asset Purchase Agreement.

20. If any person or entity that has filed financing statements, mortgages, mechanic's liens, *lis pendens*, or other documents or agreements evidencing Interests in the Debtors or the Assets shall not have delivered to the Trustee prior to the Closing Date, in proper form for filing and executed by the appropriate parties, termination statements, instruments of satisfaction, releases of all Interests which the person or entity has with respect to the Debtors or the Assets or

otherwise, then (a) the Trustee is hereby authorized and directed to execute and file such statements, instruments, releases and other documents on behalf of the person or entity with respect to the Assets and (b) the Buyer is hereby authorized to file, register, or otherwise record a certified copy of this Sale Order, which, once filed, registered, or otherwise recorded, shall constitute conclusive evidence of the release of all Interests in the Assets of any kind or nature whatsoever.

21. The Debtors are hereby authorized and directed to change their corporate names in accordance with the terms set forth in the Asset Purchase Agreement. The Clerk of this Court is hereby directed to modify the official case caption to reflect such name changes in the Debtors' jointly administered cases, and the modified official case caption shall be deemed to comply with the requirements of section 342 of the Bankruptcy Code and Federal Rules of Bankruptcy Procedure 1007 and 2002.

22. All entities who are presently, or on the Closing Date may be, in possession of some or all of the Assets are hereby directed to surrender possession of the Assets to the Buyer on the Closing Date.

23. The Buyer shall have no liability or responsibility for any liability or other obligation of the Debtors arising under or related to the Assets or otherwise other than for the Surviving Obligations. Without limiting the generality of the foregoing, and except as otherwise specifically provided herein and in the Asset Purchase Agreement, the Buyer shall not be liable for any claim against the Debtors or any of their predecessors or affiliates, and the Buyer shall have no successor or transferee liabilities of any kind or character whether known or unknown as of the Closing Date, now existing or hereafter arising, whether fixed or contingent, with respect to the Debtors or any obligations of the Debtors arising prior to the Closing Date, including, but

not limited to, liabilities on account of any taxes arising, accruing, or payable under, out of, in connection with, or in any way relating to the Assets, the Debtors or their operations or activities prior to the Closing Date.

24. Under no circumstances shall the Buyer be deemed a successor of or to the Debtors for any Interest against or in the Debtors or the Assets of any kind or nature whatsoever except pursuant to the Surviving Obligations. The sale, transfer, assignment and delivery of the Assets shall not be subject to any Interests, and Interests of any kind or nature whatsoever (other than the Surviving Obligations) shall remain with, and continue to be obligations of, the Debtors. All persons holding Interests against or in the Debtors or the Assets of any kind or nature whatsoever shall be, and hereby are, forever barred, estopped, and permanently enjoined from asserting, prosecuting, or otherwise pursuing such Interests of any kind or nature whatsoever against the Buyer, its property, its successors and assigns, or the Assets with respect to any Interest of any kind or nature whatsoever such person or entity had, has, or may have against or in the Debtors, their estates, officers, directors, shareholders, or the Assets. Following the Closing Date, no holder of an Interest in the Debtors shall interfere with the Buyer's title to or use and enjoyment of the Assets based on or related to such Interest, or any actions that the Debtors may take in their Chapter 11 cases.

25. Subject to and except as otherwise provided in the Procedures Order, any amounts that become payable to the Buyer by the Debtors pursuant to the Asset Purchase Agreement or any of the documents delivered by the Debtors pursuant to or in connection with the Asset Purchase Agreement shall (a) constitute allowed superpriority administrative expense claims against the Debtors' estates with priority over any and all administrative expenses of the kind specified in Bankruptcy Code Sections 503(b) and 507(b) and (b) be paid by the Debtors in the

time and manner as provided in the Asset Purchase Agreement, without further order of this Court.

26. This Court retains jurisdiction to enforce and implement the terms and provisions of the Asset Purchase Agreement, all amendments thereto, any waivers and consents thereunder, and of each of the agreements executed in connection therewith in all respects, including, but not limited to, retaining jurisdiction to (a) compel delivery of the Assets to the Buyer, (b) resolve any disputes arising under or related to the Asset Purchase Agreement, except as otherwise provided therein, (c) interpret, implement, and enforce the provisions of this Sale Order, and (d) protect the Buyer against (i) any of the Excluded Liabilities or (ii) any Interests in the Debtors or the Assets, of any kind or nature whatsoever, attaching to the proceeds of the Sale.

27. Nothing contained in any plan of reorganization or liquidation confirmed in these cases or any order of this Court confirming such plan shall conflict with or derogate from the provisions of the Asset Purchase Agreement or the terms of this Sale Order.

28. The transfer of the Assets to Buyer and the assumption and assignment to Buyer of the Assumed Contracts and Assumed Liabilities pursuant to the Sale shall not subject the Buyer to any liability (other than the Surviving Obligations) with respect to the Assets, the Debtors or their operations or activities prior to the Closing Date or by reason of such transfer under the laws of the United States, any state, territory, or possession thereof, or the District of Columbia, based, in whole or in part, directly or indirectly, on any theory of law or equity, including, without limitation, any theory of successor or transferee liability.

29. The transactions contemplated by the Asset Purchase Agreement are undertaken by the Buyer in good faith, as that term is used in section 363(m) of the Bankruptcy Code, and accordingly, the reversal or modification on appeal of the authorization provided herein to

consummate the Sale shall not affect the validity of the Sale to the Buyer, unless such authorization is duly stayed pending such appeal. In the absence of a stay pending appeal, if the Buyer elects to close under the Asset Purchase Agreement at any time after entry of this Sale Order, then, with respect to the Sale, and the assumption and assignment of the Assumed Contracts approved and authorized herein, the Buyer is a purchaser in good faith of the Assets, and is entitled to all of the protections afforded by section 363(m) of the Bankruptcy Code if this Sale Order or any authorization contained herein is reversed or modified on appeal.

30. The terms and provisions of the Asset Purchase Agreement and this Sale Order shall be binding in all respects upon, and shall inure to the benefit of, the Debtors, their estates, and their creditors, the Buyer, and their respective affiliates, successors and assigns, and any affected third parties including, but not limited to, all persons asserting interests in the Assets to be sold to the Buyer pursuant to the Asset Purchase Agreement (including any claims with respect to the Excluded Liabilities), notwithstanding any subsequent appointment of any trustee(s) under any chapter of the Bankruptcy Code, as to which trustee(s) such terms and provisions likewise shall be binding.

31. The failure specifically to include any particular provisions of the Asset Purchase Agreement in this Sale Order shall not diminish or impair the effectiveness of such provision, it being the intent of the Court that the Asset Purchase Agreement be authorized and approved in its entirety.

32. The Asset Purchase Agreement and any related agreements, documents or other instruments may be modified, amended or supplemented by the parties thereto, in a writing signed by both parties, and in accordance with the terms thereof, without further order of the

Court, provided that any such modification, amendment or supplement does not have a material adverse effect on the Debtors' estates.

33. The transfer of the Assets pursuant to the Sale is a transfer pursuant to section 1146(c) of the Bankruptcy Code, and accordingly shall not be taxed under any law imposing a stamp tax or a sale, transfer, or any other similar tax.

34. This Sale Order shall be effective and enforceable immediately upon entry. The stay otherwise imposed by Fed. R. Bankr. P. 6004(g) and 6006(d) is waived. Time is of the essence in closing the transaction and the Debtors and the Buyer intend to close the Sale as soon as possible. Therefore, any party objecting to this Sale Order must exercise due diligence in filing an appeal and pursuing a stay or risk their appeal being foreclosed as moot.

35. The provisions of this Sale Order are nonseverable and mutually dependent.

Dated: Wilmington, Delaware  
\_\_\_\_\_, 2002

\_\_\_\_\_  
UNITED STATES BANKRUPTCY JUDGE

118804 1



**Exhibit D**  
**Sale Procedures Order**

NB1:578505.7

IN THE UNITED STATES BANKRUPTCY COURT  
FOR THE DISTRICT OF DELAWARE

IN RE:	)	Chapter 11
	)	
NAPSTER, INC.,	)	Jointly Administered
a Delaware corporation, et al.,	)	Case Nos. 02-11573 (PJW)
	)	
Debtors.	)	
_____		Related Pleading: Dkt. #372

**ORDER (A) AUTHORIZING THE TRUSTEE TO PROCEED WITH A SALE OF THE DEBTORS' ASSETS, (B) ESTABLISHING PROCEDURES TO BE EMPLOYED IN CONNECTION WITH THE SALE INCLUDING APPROVAL OF A BREAK-UP FEE, (C) APPROVING FORM AND MANNER OF NOTICE OF MOTION APPROVING SALE, (D) SETTING SALE HEARING AND OBJECTION DEADLINES, AND (E) GRANTING RELATED RELIEF**

Upon consideration of Motion (the "Motion") of the Chapter 11 Trustee for an Order (a) authorizing the Trustee to proceed with a sale (the "Sale") of assets of the Debtors, (b) establishing procedures to be employed in connection with the Sale including approval of a break-up fee (the "Break-Up Fee"), (c) approving form and notice of the Motion approving the Sale (the "Sale Motion"), (d) setting dates for a sale hearing (the "Sale Hearing") and deadlines for the filing of objections (the "Objection Deadline") to the Sale and objections to cure payments proposed to be paid in connection with the assignment and assumption of executory contracts and unexpired leases as part of the Sale, and (e) granting related relief<sup>1</sup>;

The Court having held a hearing on the Motion; and due and adequate notice of the Motion having been provided; and it appearing that the relief requested in the Motion is in the best interests of the Debtors, their estates and creditors and other parties in interest; and good cause appearing therefore; it is hereby:

<sup>1</sup> Capitalized terms used herein and not defined herein have the meanings ascribed to such terms in the Motion.

**FOUND AND DETERMINED THAT:<sup>2</sup>**

A. The Debtors and the Trustee have articulated good and sufficient reasons for approving (i) the manner of notice of the Motion, the hearing to approve the Sale and the assumption and assignment of the Assumed Contracts, (ii) the form of notice of the Sale Motion and the Sale Hearing, (iii) the form of notice of the assumption and assignment of the Assumed Contracts to be filed with the Court and served on parties to each Assumed Contract and (iv) the procedures set forth herein.

B. Subject to the findings and conditions set forth below in Paragraph 7, the Debtors' payment of the Break-Up Fee is (a) an actual and necessary cost and expense of preserving the Debtors' estates, within the meaning of Bankruptcy Code Section 503(b), (h) of substantial benefit to the Debtors' estates, (c) reasonable and appropriate, including in consideration of the New Financing and the efforts that have been and will be expended by the Prospective Buyer, (d) necessary to ensure that the Prospective Buyer will continue its proposed acquisition of the Purchased Assets and (e) only payable to the Prospective Buyer in the event that the Debtors sell any or all of the Purchased Assets to another party. The Break-Up Fee is a material inducement for, and conditions of, the Prospective Buyer's entry into the Asset Purchase Agreement. The Prospective Buyer is unwilling to commit to hold open its offer to purchase the Purchased Assets under the terms of the Asset Purchase Agreement unless it is assured payment of the Break-Up Fee. Thus, assurance to the Prospective Buyer of the Break-Up Fee will promote competitive bidding. Further, the Prospective Buyer has provided a benefit to the Debtors' estates by

---

<sup>2</sup> Findings of fact shall be construed as conclusions of law and conclusions of law shall be construed as findings of fact when appropriate. See Fed. R. Bankr. P. 7052.

increasing the likelihood that the price for which the Purchased Assets are sold will reflect their true worth.

C. The procedures set forth herein are reasonable and appropriate and represent the best method for maximizing the return for the Purchased Assets.

**IT IS HEREBY ORDERED THAT:**

1. The Motion is granted as set forth herein.
2. Provided that, on or before November 15, 2002, the Trustee has (A) filed (i) a motion to approve the Sale to the Prospective Buyer, including disclosure of the Prospective Buyer's identity, and including assumption and assignment of certain executory contracts; (ii) a copy of the asset purchase agreement executed by the parties (the "Asset Purchase Agreement"); and (iii) a designation of the contracts to be assigned to the Prospective Buyer with proposed cure payments; and (B) served and published notice of the Sale and served the Assumption Notices including proposed cure amounts to the non-debtor parties to the Assumed Contracts, the following procedures, hearing dates and objection deadlines (collectively, the "Procedures") are hereby approved:

November 22, 2002

Deadline for any person or entity making a competing bid to acquire the assets of the Debtors (a "Competing Bidder") to deliver to the Trustee and the Committee (A) a copy of the Asset Purchase Agreement revised to show the competing bidder as the Buyer and a cash purchase price that exceeds the aggregate of (i) the cash portion of the purchase price under the Asset Purchase Agreement (currently \$5.2 million)<sup>1</sup>, plus

<sup>1</sup> The cash portion of the purchase price under the Asset Purchase Agreement includes advances made by an affiliate of the Prospective Buyer under the New Financing (as defined in the Motion). The amount of advances to the Debtors under the New Financing is currently \$200,000. However, the New Financing provides that under certain circumstances, the Debtors may request additional advances of up to \$50,000 in which case the amount of the advances included in the purchase price would be a total aggregate amount between \$200,000 and \$250,000. In the event that the Prospective Buyer is the successful bidder, the

(ii) the amount of the Break-up Fee (\$200,000) and by an amount not less than \$150,000 and not subject to any contingency for due diligence or otherwise and no more burdensome to the Debtors in any manner than the Asset Purchase Agreement (as so revised, the "Competing Asset Purchase Agreement"); (B) evidence satisfactory to the Trustee and the Committee of the Competing Bidder's financial ability to close a transaction under the Competing Asset Purchase Agreement without delay; (C) a cashier's check in an amount equal to no less than ten percent (10%) of the cash portion of the purchase price in the Competing Asset Purchase Agreement (the "Deposit"); and (D) a written agreement of the Competing Bidder to keep its final and highest bid open pending a closing of a sale to an entity other than the Competing Bidder.

November 25, 2002

Deadline for filing and serving objections (the "Objection Deadline") to (A) the Sale Motion, (B) the assumption and assignment of the Assumed Contracts as part of the Sale and (c) objections to the proposed cure payments under such Assumed Contracts.

November 27, 2002

Hearing to approve the Sale.

3. If another Competing Bidder or the Prospective Buyer elects to submit a subsequent competing bid after an Initial Competing Bid has been accepted (a "Subsequent Competing Bid"), such Subsequent Competing Bid must be in an amount that exceeds the cash portion of the Initial Competing Bid by not less than \$100,000. Any

---

amount of the advances under the New Financing would be applied to the purchase price under the Asset Purchase Agreement. In the event the Prospective Buyer is not the successful bidder for the Purchased Assets, it shall be entitled to repayment of the New Financing in accordance with the terms and conditions of the New Financing Order entered November 1, 2002.

The Deposit will be either (a) credited toward the purchase price if a sale is completed with the Competing Bidder making such Deposit, (b) forfeited by such Competing Bidder if a sale to such Competing Bidder is not completed for reasons primarily attributable to the Competing Bidder, or (c) returned to such Competing Bidder if a sale is completed with another Competing Bidder or the Prospective Buyer.

further bid after a Subsequent Competing Bid must provide for aggregate cash consideration in an amount not less than \$100,000 more than the amount of the last bid that was accepted by the Trustee.

4. The failure of any objecting person or entity to timely file its objection by the Objection Deadline shall be a bar to the assertion, at the Sale Hearing or thereafter, of any objection to the Motion, the Sale Motion, the Sale, or the Debtors' consummation and performance of the Asset Purchase Agreement, if authorized by the Court.

5. On or before November 15, 2002, the Debtors shall file with the Court and serve on all creditors and non-debtor Parties to Assumed Contracts the Notice of (A) Sale Hearing, (B) Potential Assumption and Assignment of Certain Agreements, and (C) Procedures for Submission of Competing Bids (the "Notice"), in the form attached as Exhibit A. Any party to an Assumed Contract that seeks to assert a claim for a Cure Amount in connection with the Debtors' proposed assumption and assignment thereof, or who otherwise objects to such assumption and assignment must timely file and serve its objection by the Objection Deadline including appropriate documentation in support thereof, indicating (a) any alleged cure amount with respect to the Assumed Contract(s) to which it is a party and (b) any objection to the Debtors' proposed assumption and assignment thereof. For each Assumed Contract for which no cure amount is alleged to be due and owing and for which no objection to assumption and assignment thereof is filed and received by the Objection Deadline, there shall be deemed to be no default or arrearages existing that need be cured as a condition to the Debtors' assumption and assignment of such Assumed Contract, and the Debtors shall be authorized to assume and assign such Assumed Contract to the Prospective Buyer or successful Competing Bidder

(such assignee, the "Buyer"), and the non-Debtor party to the Assumed Contract shall be forever barred from asserting any other claims against the Debtors, the Buyer, or the property of either of them, as to such Assumed Contract. For each Assumed Contract for which a cure amount is alleged to be due and owing and for which no objection to assumption and assignment thereof is filed and received by the Objection Deadline, the Assumed Contract may be assumed and assigned to the Buyer on the closing date of the Sale and the cure amount set forth in notice of the assumption and assignment of the Assumed Contract shall be controlling, notwithstanding anything to the contrary in any Assumed Contract or any other document, and the non-Debtor party to the Assumed Contract shall be forever barred from asserting any other claims against the Debtors, the Buyer, or the property of either of them, as to such Assumed Contract.

6. The Trustee shall have the right under these Procedures to reject any Competing Bidder's offer which, in his judgment, is inadequate or insufficient or which is contrary to the best interests of the Debtors' estates.

7. Payment of the Break-up Fee to the Prospective Buyer is hereby provisionally approved in the amount of up to \$200,000, for the reasons set forth in the Motion, subject to the Court finding at the Sale Hearing that the Prospective Buyer satisfies the standards of a good faith purchaser within the meaning of 11 U.S.C. §363(m).

8. The Trustee shall transmit copies of this Order, the Sale Motion, and the Asset Purchase Agreement, on or before November 15, 2002 to: (i) the Office of the United States Trustee, (ii) counsel for Napco, (iii) counsel for the Debtors, (iv) counsel for the Committee, (v) counsel to the Prospective Buyer; (vi) counsel to Bertelsmann; (vii) all entities who have filed and served requests for notices in these cases, (viii) all other

parties-in-interest, (ix) all appropriate state and local taxing authorities which may be affected by the proposed sale, and (x) all entities that have previously submitted written bids to acquire the Debtors' assets, and (xi) all parties to the executory contracts and unexpired leases which are impacted by the contemplated sale.

9. The Trustee is authorized and empowered to take or perform such actions and expend such funds as may be necessary to effectuate the terms of this Order.

Dated: Wilmington, Delaware

November 15 2002

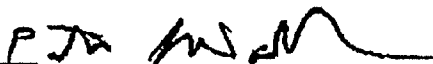
  
\_\_\_\_\_  
The Honorable Peter J. Walsh  
United States Bankruptcy Judge

118713.1



**Exhibit "A"**

IN THE UNITED STATES BANKRUPTCY COURT  
FOR THE DISTRICT OF DELAWARE

IN RE:	)	Chapter 11
	)	
NAPSTER, INC.,	)	Jointly Administrated
a Delaware corporation, et al.,	)	Case Nos. 02-11573 (PJW)
	)	
Debtors.	)	Hearing Date: November 27, 2002 @ 9:30 a.m.
	)	Objection Deadline: November 25, 2002 @ 4:00 p.m.

**NOTICE OF (A) SALE HEARING, (B) POTENTIAL ASSUMPTION  
AND ASSIGNMENT OF CERTAIN AGREEMENTS, AND  
(C) PROCEDURES FOR SUBMISSION OF COMPETING BIDS**

**TO ALL INTERESTED PARTIES:**

**PLEASE TAKE NOTICE** that on November 15, 2002, Hobart G. Truesdell, in his capacity as chapter 11 trustee (the "Trustee") of the above-captioned debtors (collectively, the "Debtors"), filed a Motion (the "Sale Motion") for an Order Under Sections 105(a), 363, 365 and 1146(c) of the Bankruptcy Code and Rules 2002, 6004, 6006 and 9014 of the Federal Rules of Bankruptcy Procedure (a) Approving Asset Purchase Agreement; (b) Authorizing the Sale of Substantially All of the Debtors' Assets, (c) Authorizing Assumption and Assignment of Certain Executory Contracts and (d) Granting Other Related Relief.

**PLEASE TAKE FURTHER NOTICE** that a hearing on the Sale Motion (the "Sale Hearing") is scheduled for November 27, 2002 at 11:00 a.m. before the Honorable Peter J. Walsh at the United States Bankruptcy Court, 824 Market Street, Wilmington, Delaware.

**PLEASE TAKE FURTHER NOTICE** that, pursuant to the procedures attached hereto as Exhibit "A" (the "Procedures"), any person or entity making a competing bid to acquire the Debtors' assets (a "Competing Bidder") must deliver to the Trustee and the Official Committee of Unsecured Creditors (the "Committee") the items set forth in the Procedures on or before November 22, 2002 at 4:00 p.m. (Eastern time), including a copy of

the Asset Purchase Agreement revised as required by the Procedures (a copy of the Asset Purchase Agreement is attached hereto as Exhibit "B")

**PLEASE TAKE FURTHER NOTICE** that the sale of the Debtors' assets will be free and clear of all liens, claims, interests and encumbrances pursuant to section 363 of the Bankruptcy Code, and includes the possible assumption and assignment to the successful bidder of certain of the Debtors' executory contracts (collectively, the "Assumed Contracts") identified on the schedule attached hereto as Exhibit C (the "Assumed Contracts List") as outlined herein. Each Assumed Contract may be assumed by the Trustee, as representative of the Debtors' estates, and assigned to the party or parties identified as the "Assignee" for the applicable Assumed Contract upon the closing of the Proposed Sale. Cure amounts for the Assumed Contracts, if any, required to be paid under section 365(b) of the Bankruptcy Code (collectively, the "Cure Amounts"), are identified on the Assumed Contracts List. The Trustee and the Prospective Buyer reserve the right to (i) remove any Assumed Contract from the Assumed Contracts List (collectively, the "Removed Agreements") at any time prior to the closing of the Proposed Sale; and (ii) in the Trustee's sole discretion, thereafter reject any of the Removed Agreements.

**PLEASE TAKE FURTHER NOTICE** that the Debtors' assets sold to the Prospective Buyer or other successful bidder shall include certain MP3 files ("MP3's") and Compact Disks ("CD's") that may contain or include copyrighted material or content subject to certain use restrictions. If and to the extent any MP3's and CD's containing or including copyrighted material or content subject to use restrictions are transferred to the Prospective Buyer or other successful bidder, the Prospective Buyer or other successful bidder shall take

possession of and store such MP3's and CD's but shall not use such MP3's and CD's without the consent of the applicable parties.

**PLEASE TAKE FURTHER NOTICE** that, any objection (an "Objection") to (a) the Sale, (b) the proposed assumption and assignment of one or more of the Assumed Contracts to the applicable Assignee and Assignees, (c) a Cure Amount and/or (d) the proposed transfer of the MP3's and CD's containing or including copyrighted material or content subject to use restrictions to the Prospective Buyer or other successful bidder must: (i) be in writing; (ii) state with specificity the nature of the objection; and (iii) be filed with the Court and served so as to be *received* by the Court and the following parties: (A) proposed attorneys for the Trustee, (x) Ashby & Geddes, 222 Delaware Ave, Wilmington, DE, 19899, Attn: William P. Bowden, Esq., facsimile no. (302) 654-2067 and (y) Morrison & Foerster LLP, 1290 Avenue of the Americas, New York, NY 10104, Attn: John R. Hempill, Esq., facsimile no. (212) 468-7900; (B) attorneys for the Official Committee of Unsecured Creditors (x) Greenberg Traurig, LLP, 1000 West Street, Suite 1540, Wilmington, Delaware 19801, Attn: Scott D. Cousins, Esq., facsimile no. (302) 661-7360 and (y) Greenberg Traurig, LLP, The MetLife Building, 200 Park Avenue, New York, NY 10166, Attn: Rick B. Antonoff, Esq., facsimile no. (212) 801-6400; (C) attorneys for the Prospective Buyer, O'Melvey & Myers LLP, 610 Newport Center Drive, 17<sup>th</sup> Floor, Newport Beach, CA 92660, Attn: Suzanne Uhland, Esq., facsimile no. (949) 823-6994; and (D) the United States Trustee, 844 Market Street, Room 2313, Lockbox 35, Wilmington, Delaware 19801, Attn: Frank Perch, Esq., facsimile no. (302) 573-6497 on or before 4:00 p.m., Eastern Time, on November 25, 2002. Objections filed in accordance with the foregoing procedures will be heard at the Sale Hearing.

**PLEASE TAKE FURTHER NOTICE** that any party claiming a right or interest in any of the Purchased Assets, including the Assumed Contracts, that does not file and serve an Objection in accordance with the foregoing procedures shall be forever barred, prohibited, estopped, stayed and otherwise disabled from prosecuting such right or interest against the Prospective Buyer or Assignee, the Debtors or any of their estates, or against and of their respective properties.

**PLEASE TAKE FURTHER NOTICE** that, except as otherwise set forth herein, all inquiries concerning the Procedures should be made to: (a) Attorneys for the Trustee: John R. Hempill, Esq., Morrison & Foerster LLP, 1290 Avenue of the Americas, New York, NY 10104 (phone: (212) 468-8000) (facsimile: (212) 468-7900) or (b) attorneys for the Committee: Rick B. Antonoff, Esq., Greenberg Traurig LLP, 200 Park Avenue, New York, NY 10166 (phone: (212) 801-9200) (facsimile: (212) 801-6400).

Dated: November 15, 2002

**ASHBY & GEDDES**

William P. Bowden (#2553)  
Ricardo Palacio (#3765)  
222 Delaware Avenue, 17th Fl.  
Wilmington, DE 19801  
(302) 654-1888

- and -

John R. Hempill, Esq.  
**MORRISON & FOERSTER**  
1290 Avenue of the Americas  
New York, NY 10104  
(212) 468-8000

**ATTORNEYS FOR HOBART G. TRUESDELL,  
CHAPTER 11 TRUSTEE**

EXHIBIT A

PROCEDURES

1. Any person or entity making a competing bid to acquire the assets of the Debtors (a "Competing Bidder") must deliver to the Trustee and the Committee no later than November 22, 2002 at 4:00 p.m. (Eastern time) a copy of the Asset Purchase Agreement revised to show the Competing Bidder as the Buyer and a cash purchase price that exceeds the aggregate of (i) the cash portion of the purchase price under the Asset Purchase Agreement (currently \$5.2 million)<sup>1</sup> plus (ii) the amount of the Break-up Fee (\$200,000), by an amount not less than \$150,000 (the "Initial Competing Bid") and not subject to any contingency for due diligence or otherwise and no more burdensome to the Debtors in any manner than the Asset Purchase Agreement (as so revised, the "Competing Asset Purchase Agreement");
2. A Competing Bidder must deliver to the Trustee and the Committee evidence satisfactory to the Trustee and the Committee of the Competing Bidder's financial ability to close a transaction under the Competing Asset Purchase Agreement without delay; (C) a cashier's check in an amount equal to no less than ten percent (10%) of the cash portion of the Initial Competing Bid (the "Deposit")<sup>2</sup>; and (D) a written agreement of the Competing Bidder to keep its final and highest bid open pending a closing of a sale to an entity other than the Competing Bidder.
3. If another Competing Bidder or the Buyer under the Asset Purchase Agreement elects to submit a subsequent competing bid after an Initial Competing Bid has been accepted (a "Subsequent Competing Bid"), such Subsequent Competing Bid must be in an amount that exceeds the cash portion of the Initial Competing Bid by not less than \$100,000.
4. Any further bid after a Subsequent Competing Bid must provide for aggregate cash consideration in an amount not less than \$100,000 more than the net amount of the last bid that was accepted by the Trustee.
5. In the event that one or more qualifying Competing Bids and/or Subsequent Competing Bids are submitted, the Trustee may conduct an auction on November 26, 2002 beginning at 10:00 a.m. at the offices of Ashby & Geddes, 222 Delaware Avenue, 17<sup>th</sup> Floor, Wilmington, DE 19801.

<sup>1</sup> The amount of the Debtors' repayment obligations under the New Financing (defined in the Motion) provided by an affiliate of the buyer under the Asset Purchase Agreement is currently \$200,000. However, the New Financing provides that under certain circumstances, the Debtors may request additional advances of up to \$50,000, in which case the Debtors' repayment obligation would be in a total aggregate amount between \$200,000 and up to \$250,000. In the event that the buyer under the Asset Purchase Agreement is the successful bidder, the amount of the Debtors' repayment obligation under the New Financing would be applied to the cash portion of the purchase price. In the event the Prospective Buyer is not the successful bidder for the Purchased Assets, it shall be entitled to repayment of the New Financing in accordance with the terms and conditions of the New Financing Order entered November 1, 2002.

<sup>2</sup> The Deposit will be either (a) credited toward the purchase price if a sale is completed with the Competing Bidder making such Deposit, (b) forfeited by such Competing Bidder if a sale to such Competing Bidder is not completed for reasons primarily attributable to the Competing Bidder, or (c) returned to such Competing Bidder if a sale is completed with another Competing Bidder or the Prospective Buyer.

6. The Trustee will reserve the right under these Procedures to reject any Competing Bid and/or Subsequent Competing Bid which, in his judgment, is inadequate or insufficient or which is contrary to the best interests of the Debtors' estates.

**EXHIBIT C**



Int. Cls.: 9, 38 and 42

Prior U.S. Cls.: 21, 23, 26, 36, 38, 100, 101 and 104

United States Patent and Trademark Office

Reg. No. 2,575,170

Registered June 4, 2002

TRADEMARK  
SERVICE MARK  
PRINCIPAL REGISTER

NAPSTER

NAPSTER, INC. (DELAWARE CORPORATION)  
600 CHESAPEAKE DRIVE  
REDWOOD CITY, CA 94063

FOR: COMPUTER SOFTWARE TO ENABLE PEER-TO PEER NETWORKING AND FILE SHARING; SEARCH ENGINE SOFTWARE; COMPUTER SOFTWARE FOR CONDUCTING AND COORDINATING REAL-TIME AND ASYNCHRONOUS COMMUNICATIONS AMONG COMPUTER USERS SHARING INFORMATION AND AUDIO DATA VIA ELECTRONIC COMMUNICATIONS NETWORKS, IN CLASS 9 (U.S. CLS. 21, 23, 26, 36 AND 38).

FIRST USE 6-0-1999; IN COMMERCE 6-0-1999.

FOR: TELECOMMUNICATIONS SERVICES, NAMELY, PROVIDING ONLINE CHAT ROOMS FOR TRANSMISSION OF MESSAGES AMONG COMPUTER USERS CONCERNING GENERAL INTEREST TOPICS, IN CLASS 38 (U.S. CLS. 100, 101 AND 104).

FIRST USE 6-0-1999; IN COMMERCE 6-0-1999.

FOR: INTERNET SERVICES, NAMELY, CREATING INDEXES OF INFORMATION, SITES AND OTHER RESOURCES AVAILABLE ON GLOBAL COMPUTER NETWORKS FOR OTHERS; INTERNET SERVICES, NAMELY PROVIDING USERS OF ELECTRONIC COMMUNICATIONS NETWORKS WITH MEANS OF IDENTIFYING, LOCATING, GROUPING, DISTRIBUTING, AND MANAGING DATA AND LINKS TO THIRD-PARTY COMPUTER SERVERS, COMPUTER PROCESSORS AND COMPUTER USERS; INTERNET SERVICES, NAMELY SEARCHING, BROWSING AND RETRIEVING INFORMATION, SITES, AND OTHER RESOURCES AVAILABLE ON GLOBAL COMPUTER NETWORKS FOR OTHERS; INTERNET SERVICES, NAMELY, ORGANIZING CONTENT OF INFORMATION PROVIDED OVER A GLOBAL COMPUTER NETWORK ACCORDING TO USER PREFERENCE, IN CLASS 42 (U.S. CLS. 100 AND 101).

FIRST USE 6-0-1999; IN COMMERCE 6-0-1999.

SER. NO. 75-981,245, FILED 6-28-2000.

LA TONIA FISHER, EXAMINING ATTORNEY

**EXHIBIT D**

Int. Cls.: 9 and 42

Prior U.S. Cls.: 21, 23, 26, 36, 38, 100, and 101

Reg. No. 2,841,431

United States Patent and Trademark Office

Registered May 11, 2004

**TRADEMARK  
SERVICE MARK  
PRINCIPAL REGISTER**

**NAPSTER**

ROXIO, INC. (DELAWARE CORPORATION)  
455 EL CAMINO REAL  
SANTA CLARA, CA 95050

FOR: COMPUTER SOFTWARE FOR THE TRANSMISSION OF AUDIO, GRAPHICS, TEXT, AND DATA OVER COMMUNICATIONS NETWORKS; COMPUTER SOFTWARE FOR THE STREAMING TRANSMISSION OF AUDIO, VIDEO, GRAPHICS, TEXT AND DATA OVER COMMUNICATION NETWORKS; COMPUTER SOFTWARE FOR STORAGE OF AUDIO, VIDEO, GRAPHICS, TEXT AND DATA ON COMMUNICATIONS NETWORKS USERS; COMPUTER SOFTWARE FOR SECURE, ENCRYPTED ELECTRONIC TRANSFER OF AUDIO, VIDEO, GRAPHICS AND DATA OVER COMMUNICATIONS NETWORKS; COMPUTER SOFTWARE FOR ENCRYPTION FOR COMMUNICATIONS, IN CLASS 9 (U.S. CLS. 21, 23, 26, 36 AND 38).

FIRST USE 10-29-2003; IN COMMERCE 10-29-2003.

FOR: LICENSING OF INTELLECTUAL PROPERTY, COMPUTER CONSULTATION; COMPUTER

NETWORK DESIGN SERVICE OR OTHERS; COMPUTER SYSTEMS DESIGN AND ANALYSIS SERVICES FOR OTHERS, COMPUTER SOFTWARE DESIGN FOR OTHERS; COMPUTER SOFTWARE CONSULTATION; COMPUTER SERVICES, NAMELY PROVIDING CUSTOMIZED WEBPAGES FEATURING USER-DEFINED INFORMATION, WHICH INCLUDES SEARCH ENGINES AND ONLINE WEB LINKS TO NEWS, WEATHER, SPORTS, CURRENT EVENTS, REFERENCE MATERIALS, AND CUSTOMIZED EMAIL MESSAGES, ALL IN A WIDE RANGE OF USER-DEFINED FIELDS; COMPUTER SERVICES, NAMELY PROVIDING SEARCH ENGINES FOR OBTAINING DATA VIA ELECTRONIC COMMUNICATIONS NETWORK, IN CLASS 42 (U.S. CLS. 100 AND 101).

FIRST USE 10-29-2003; IN COMMERCE 10-29-2003.

SN 78-039,019, FILED 12-12-2000

HOWARD SMIGA, EXAMINING ATTORNEY

**EXHIBIT E**

Int. Cls.: 35, 38, 41, and 42

Prior U.S. Cls.: 100, 101, 102, 104, and 107

Reg. No. 2,843,786

United States Patent and Trademark Office

Registered May 18, 2004

**SERVICE MARK  
PRINCIPAL REGISTER**

**NAPSTER**

ROXIO, INC. (DELAWARE CORPORATION)  
455 EL CAMINO REAL  
SANTA CLARA, CA 95050

FOR: BUSINESS CONSULTATION; PRODUCT MERCHANDISING; LICENSING OF COMPUTER SOFTWARE AND OF ENTERTAINMENT PRODUCTS AND SERVICES; DISSEMINATION OF ADVERTISING FOR OTHERS VIA COMMUNICATIONS NETWORKS; RETAIL STORE SERVICES FEATURING ENTERTAINMENT PRODUCTS AND APPAREL; RETAIL STORE SERVICES PROVIDED VIA COMMUNICATIONS NETWORKS FEATURING ENTERTAINMENT PRODUCTS AND APPAREL, IN CLASS 35 (U.S. CLS. 100, 101 AND 102).

FIRST USE 10-29-2003; IN COMMERCE 10-29-2003.

FOR: ELECTRONIC TRANSMISSION OF AUDIO AND VIDEO FILES VIA COMMUNICATIONS NETWORKS; PROVIDING ELECTRONIC BULLETIN BOARDS; CHAT ROOMS AND COMMUNITY FOR A TRANSMISSION OF MESSAGES AMONG USERS CONCERNING MUSIC, NEWS, CURRENT EVENTS, POLITICS, ENTERTAINMENT AND ARTS AND LEISURE; TRANSMISSION OF PEER TO PEER NETWORKING AND FILE SHARING INFORMATION VIA COMMUNICATIONS NETWORKS, IN CLASS 38 (U.S. CLS. 100, 101 AND 104).

FIRST USE 10-29-2003; IN COMMERCE 10-29-2003.

FOR: PROVIDING DATABASES AND DIRECTORIES IN THE FIELDS OF MUSIC, VIDEO, RADIO, TELEVISION, NEWS, SPORTS, GAMES, CULTURAL EVENTS, ENTERTAINMENT, AND

ARTS AND LEISURE VIA COMMUNICATIONS NETWORKS; PROVIDING INFORMATION, AUDIO, VIDEO, GRAPHICS, TEXT AND OTHER MULTIMEDIA CONTENT IN THE FIELDS OF MUSIC, VIDEO, RADIO, TELEVISION, NEWS, SPORTS, GAMES, CULTURAL EVENTS, ENTERTAINMENT, AND ARTS AND LEISURE VIA COMMUNICATIONS NETWORKS; MUSIC PUBLISHING SERVICES; PUBLISHING OF TEXT, GRAPHIC, AUDIO AND VIDEO WORKS VIA COMMUNICATIONS NETWORKS; MATCHING USERS FOR THE TRANSFER OF MUSIC, VIDEO, AND AUDIO RECORDINGS VIA COMMUNICATIONS NETWORKS; PROVIDING EDUCATIONAL SYMPOSIA VIA COMMUNICATIONS NETWORKS IN THE FIELDS OF MUSIC, VIDEO, ENTERTAINMENT NEWS, POLITICS, AND ARTS AND LEISURE, IN CLASS 41 (U.S. CLS. 100, 101 AND 107)

FIRST USE 10-29-2003; IN COMMERCE 10-29-2003.

FOR: LICENSING OF INTELLECTUAL PROPERTY; PROVIDING SEARCH ENGINES FOR OBTAINING DATA VIA COMMUNICATIONS NETWORKS; PROVIDING DATABASES AND DIRECTORIES VIA COMMUNICATIONS NETWORKS FOR OBTAINING DATA IN THE FIELDS OF POLITICS AND GENERAL NEWS, IN CLASS 42 (U.S. CLS. 100 AND 101).

FIRST USE 10-29-2003; IN COMMERCE 10-29-2003.

SN 78-014,821, FILED 6 -28-2000.

ANDREW BENZMILLER, EXAMINING ATTORNEY

**EXHIBIT F**

Int. Cls.: 9, 35, 38, 41, and 42

Prior U.S. Cls.: 21, 23, 26, 36, 38, 100, 101, 102, 104,  
and 107

United States Patent and Trademark Office

Reg. No. 2,843,405

Registered May 18, 2004

TRADEMARK  
SERVICE MARK  
PRINCIPAL REGISTER



ROXIO, INC. (DELAWARE CORPORATION)  
455 EL CAMINO REAL  
SANTA CLARA, CA 95050

FOR: COMPUTER SOFTWARE TO ENABLE PEER-TO-PEER NETWORKING AND FILE SHARING; SEARCH ENGINE SOFTWARE; COMPUTER SOFTWARE FOR THE TRANSMISSION OF AUDIO, GRAPHICS, TEXT, AND DATA OVER COMMUNICATIONS NETWORKS; COMPUTER SOFTWARE FOR THE STREAMING TRANSMISSION OF AUDIO, VIDEO, GRAPHICS, TEXT AND DATA OVER COMMUNICATIONS NETWORKS; COMPUTER STORAGE TO ENABLE COMMUNICATIONS AMONG COMPUTER OR COMMUNICATIONS NETWORK USERS; COMPUTER SOFTWARE FOR SECURE, ENCRYPTED ELECTRONIC TRANSFER OF AUDIO, VIDEO, GRAPHICS AND DATA OVER COMMUNICATIONS NETWORKS; COMPUTER SOFTWARE FOR ENCRYPTION OF COMMUNICATIONS, IN CLASS 9 (U.S. CLS. 21, 23, 26, 36 AND 38).

FIRST USE 10-29-2003; IN COMMERCE 10-29-2003.

FOR: BUSINESS CONSULTATION; PRODUCT MERCHANDISING; LICENSING OF COMPUTER SOFTWARE; DISSEMINATION OF ADVERTISING FOR OTHERS VIA COMMUNICATIONS NETWORKS; RETAIL STORE SERVICES FEATURING ENTERTAINMENT PRODUCTS AND APPAREL; RETAIL STORE SERVICES PROVIDED VIA COMMUNICATIONS NETWORKS FEATURING ENTERTAINMENT PRODUCTS AND APPAREL, IN CLASS 35 (U.S. CLS. 100, 101 AND 102).

FIRST USE 10-29-2003; IN COMMERCE 10-29-2003.

FOR: TRANSMISSION OF AUDIO AND VIDEO FILES VIA COMMUNICATIONS NETWORKS; PRO-

VIDING ELECTRONIC BULLETIN BOARDS, CHAT ROOMS AND COMMUNITY FORA FOR THE TRANSMISSION OF MESSAGES AMONG USERS CONCERNING MUSIC, NEWS, CURRENT EVENTS, POLITICS, ENTERTAINMENT AND ARTS AND LEISURE; TRANSMISSION OF PEER TO PEER NETWORKING AND FILE SHARING INFORMATION VIA COMMUNICATIONS NETWORKS; TELECOMMUNICATIONS SERVICES, NAMELY, PROVIDING ONLINE CHAT ROOMS FOR TRANSMISSION OF MESSAGES AMONG COMPUTER USERS CONCERNING GENERAL INTEREST TOPICS, IN CLASS 38 (U.S. CLS. 100, 101 AND 104).

FIRST USE 10-29-2003; IN COMMERCE 10-29-2003.

FOR: PROVIDING DATABASES AND DIRECTORIES IN THE FIELDS OF MUSIC, VIDEO, RADIO, TELEVISION, NEWS, SPORTS, GAMES, CULTURAL EVENTS, ENTERTAINMENT, AND ARTS AND LEISURE VIA COMMUNICATIONS NETWORKS; PROVIDING INFORMATION, AUDIO, VIDEO, GRAPHICS, TEXT AND OTHER MULTIMEDIA CONTENT IN THE FIELDS OF MUSIC, VIDEO, RADIO, TELEVISION, ENTERTAINMENT NEWS, SPORTS, GAMES, CULTURAL EVENTS, ENTERTAINMENT AND ARTS AND LEISURE VIA COMMUNICATIONS NETWORKS; MUSIC PUBLISHING SERVICES; PUBLISHING OF TEXT, GRAPHIC, AUDIO AND VIDEO WORKS VIA COMMUNICATIONS NETWORKS; MATCHING USERS FOR THE TRANSFER AND SHARING OF MUSIC, VIDEO, AND AUDIO RECORDINGS VIA COMMUNICATIONS NETWORKS; PROVIDING EDUCATIONAL SYMPOSIA VIA COMMUNICATIONS NETWORKS IN THE FIELDS OF MUSIC, VIDEO, ENTERTAINMENT, NEWS, POLITICS, AND ARTS AND LEISURE, IN CLASS 41 (U.S. CLS. 100, 101 AND 107).

FIRST USE 10-29-2003; IN COMMERCE 10-29-2003.

FOR: LICENSING OF INTELLECTUAL PROPERTY; PROVIDING SEARCH ENGINES FOR OBTAINING DATA VIA COMMUNICATIONS NETWORK; PROVIDING DATABASES AND DIRECTORIES VIA COMMUNICATIONS NETWORKS FOR OBTAINING DATA IN THE FIELD OF POLITICS AND GENERAL NEWS; INTERNET SERVICES, NAMELY, CREATING INDEXES OF INFORMATION, SITES AND OTHER RESOURCES AVAILABLE ON COMMUNICATIONS NETWORKS FOR OTHERS; INTERNET SERVICES, NAMELY, PROVIDING USERS OF COMMUNICATIONS NETWORKS WITH MEANS OF IDENTIFYING, LOCATING, GROUPING, DISTRIBUTING, AND MANAGING DATA AND LINKS TO THIRD-PARTY COMPUTER SER-

VERS, COMPUTER PROCESSORS AND COMPUTER USERS; INTERNET SERVICES, NAMELY, SEARCHING, BROWSING AND RETRIEVING INFORMATION, SITES, AND OTHER RESOURCES AVAILABLE ON COMMUNICATIONS NETWORKS FOR OTHERS; INTERNET SERVICES, NAMELY, ORGANIZING CONTENT OF INFORMATION PROVIDED OVER A COMMUNICATIONS NETWORKS ACCORDING TO USER PREFERENCE, IN CLASS 42 (U.S. CLS. 100 AND 101).

FIRST USE 10-29-2003; IN COMMERCE 10-29-2003.

SN 76-137,325, FILED 9-27-2000.

ANDREW BENZMILLER, EXAMINING ATTORNEY



**EXHIBIT G**

**IN THE UNITED STATES PATENT AND TRADEMARK OFFICE  
BEFORE THE TRADEMARK TRIAL AND APPEAL BOARD**

In the Matter of:

Trademark Registration No.	2575170
Registration Date:	June 4, 2002
For the Mark:	NAPSTER
Trademark Registration No.	2841431
Registration Date:	May 11, 2004
For the Mark:	NAPSTER
Trademark Registration No.	2843786
Registration Date:	May 18, 2004
For the Mark:	NAPSTER
Trademark Registration No.	2843405
Registration Date:	May 18, 2004
For the Mark:	NAPSTER & Design

SightSound Technologies, Inc.,	:	
	:	
<i>Petitioner,</i>	:	
	:	
v.	:	Cancellation No. _____
	:	
Napster, LLC,	:	
	:	
<i>Respondent.</i>	:	

Commissioner of Trademarks  
P.O. Box 1451  
Arlington, Virginia 22313-1451

**PETITION FOR CANCELLATION**

SightSound Technologies, Inc., a corporation organized under the laws of the State of Delaware, having a place of business at 311 South Craig Street, Suite 205, Pittsburgh, PA 15213 (“Petitioner”), believes that it is or will be damaged by Registration Nos. 2575170, 2841431, 2843786, and 2843405, and hereby petitions to cancel the same, with knowledge concerning its own actions and on information and belief concerning all other matters.

The name and address of the current owner of Registration Nos. 2575170, 2841431, 2843786, and 2843405 is Napster, LLC, a limited liability company organized under the laws of the State of Delaware, with an address at 455 El Camino Real, Santa Clara, California 95050 (hereinafter referred to as “Respondent”).

As grounds for this Petition, it is alleged that:

1. Respondent is the owner of record of the marks listed in Registration Nos. 2575170, 2841431, 2843786, and 2843405 (the “Napster Marks”). Respondent acquired the Napster Marks through assignments, from Napster, Inc. (the original Applicant) to Roxio, Inc. (the parent of Respondent) and then from Roxio, Inc. to Respondent.

2. In a currently-pending federal court lawsuit between Petitioner and Respondent, the Respondent filed counterclaims against Petitioner asserting causes of action for, *inter alia*, trade libel, defamation, and commercial disparagement, allegedly arising from Petitioner’s reference to the name Napster. More particularly, Respondent asserts that the following statement is false: “Napster, whose name had been synonymous with the most well-known violation of intellectual property rights . . . .”

3. Napster, Inc. (the original Applicant) was embroiled in a highly publicized battle with the music industry arising from its operation of an Internet-based “service” that facilitated rampant music piracy. Nearly twenty record companies sued Napster, Inc. for contributory and vicarious copyright infringement and related causes of action, and this action was soon joined by a class of music publishers. The court found a likelihood of success on the merits of the copyright infringement claim and issued a preliminary injunction against Napster, Inc., and stated in its opinion that Napster “*contributed to illegal copying on a scale that is without precedent.*” *A&M Records, Inc. v. Napster, Inc.*, 114 F. Supp. 2d 896, 927 (N.D. Cal. 2000).

(emphasis added). In upholding the injunction (with modification) against Napster, Inc., the Ninth Circuit confirmed the rampant infringement that Napster, Inc. was engaged in:

*Napster, by its conduct, knowingly encourages and assists the infringement of plaintiffs' copyrights.*

The district court . . . properly found that *Napster materially contributes to direct infringement.*

*Napster's failure to police* the system's "premises," combined with a showing that *Napster financially benefits from the continuing availability of infringing files* on its system, leads to the imposition of *vicarious liability.*

*A&M Records, Inc. v. Napster, Inc.*, 239 F.3d 1004, 1020, 1022, 1024 (9th Cir. 2001) (emphasis added). Thus, two federal courts have stated unequivocally that Napster, Inc. was an infringer of intellectual property rights (namely, copyrights).

4. In asserting that the Napster name (and, hence, each of the Napster Marks) was not associated with violation of intellectual property rights, Respondent has rejected the goodwill associated with the prior user, Napster, Inc., including the reputation that Napster, Inc. earned for facilitating copyright infringement on an unprecedented scale. As such, Respondent has admitted that it acquired the Napster Marks without the goodwill associated with the business.

5. Trademarks cannot be validly assigned without the goodwill of the business. A sale of a trademark divorced from its goodwill is an "assignment in gross," which operates to pass no rights to the purported assignee. Thus, the Napster Marks were not validly transferred from Napster, Inc. to the Respondent (or to its parent, Roxio, Inc.). As the Napster Marks are no longer used by the assignor, Napster, Inc., they have been abandoned. Accordingly, Registration Nos. 2575170, 2841431, 2843786, and 2843405 are subject to cancellation.

6. Petitioner is being injured by the continued presence on the Principal Register of Registration Nos. 2575170, 2841431, 2843786, and 2843405 because, *inter alia*, Petitioner's fair use rights to refer to the Napster name are being adversely affected by Respondent's continued registration of the Napster name as reflected in the registered Napster Marks.

7. Furthermore, the intent to use applications underlying Registration Nos. 2841431, 2843786, and 2843405 were improperly transferred in violation of 15 U.S.C. §1060. No application to register a mark under Section 1(b) of the Lanham Act, 15 U.S.C. §1051(b), shall be assignable prior to the filing of an amendment under Section 1(c), 15 U.S.C. §1051(c), to bring the application into conformity with Section 1(a), 15 U.S.C. §1051(a), or the filing of the verified statement of use under Section 1(d), 15 U.S.C. §1051(d), except for an assignment to a successor to the business of the applicant, or portion thereof, to which the mark pertains, if that business is ongoing and existing.

8. The applications underlying Registration Nos. 2841431, 2843786, and 2843405 were filed by Napster, Inc. based upon an intent to use the marks under Section 1(b) of the Lanham Act. These applications were still pending and no amendment to allege use (or statement of use) had been filed when they were transferred by the original owner, Napster, Inc., to Roxio, Inc. (Napster, LLC's parent) on November 27, 2002. To the extent that the business of Napster, Inc. was ongoing and existing at the time of the assignment, Roxio, Inc. was not a successor to the business of the original applicant, Napster, Inc. Accordingly, the applications underlying Registration Nos. 2841431, 2843786, and 2843405 were void as of the date of attempted assignment from Napster, Inc. to Roxio, Inc., and Registration Nos. 2841431, 2843786, and 2843405 are subject to cancellation.

9. These applications were again improperly transferred when, on June 13, 2003, Roxio, Inc. transferred them to its subsidiary, Napster, LLC. On that date, the applications were still pending and no amendment to allege use (or statement of use) had been filed. Accordingly, Registration Nos. 2841431, 2843786, and 2843405 are subject to cancellation.

10. Finally, the assignment of Registration Nos. 2575170, 2841431, 2843786, and 2843405 was invalid under 15 U.S.C. §1060 as there has been a substantial change in the services marketed and/or rendered under the Napster Marks, and, accordingly, there was no transfer of the goodwill to which the marks pertained. Where a transferred mark is to be used on a new and different product or service, any goodwill that the mark itself might represent cannot legally be assigned. Respondent's services under the Napster Marks are so different from the old services that the goodwill was not legally assigned, and to allow continued use and registration of the marks would work a deception upon the public. Whether the new service is better or worse than the original is wholly immaterial; the substitution of one service for a different one worked a forfeiture on whatever trademark rights Respondent attempted to acquire.

WHEREFORE, Petitioner prays this Petition for Cancellation be sustained in favor of Petitioner and that Registration Nos. 2575170, 2841431, 2843786, and 2843405 be canceled.

Please address all future communications regarding this cancellation to:

William K. Wells  
KENYON & KENYON  
1500 K Street, N.W., Suite 700  
Washington, DC 20005  
Tel.: (202) 220-4200  
Fax: (202) 220-4201

Please charge the filing fees of \$4,200.00, and any other fees associated with this proceeding to Deposit Account 11-0600.

Respectfully submitted,

s/ William K. Wells  
William K. Wells  
Brian S. Mudge  
Susan A. Smith  
KENYON & KENYON  
1500 K Street, N.W , Suite 700  
Washington, DC 20005  
Tel.: (202) 220-4200  
Fax: (202) 220-4201

*Counsel for Petitioner SightSound Technologies, Inc.*

**EXHIBIT H**



**IN THE UNITED STATES BANKRUPTCY COURT  
FOR THE DISTRICT OF DELAWARE**

<b>IN RE: ENCO RECOVERY CORP.</b>	)	<b>Chapter 11</b>
<b>f/k/a NAPSTER, INC.,</b>	)	
<b>a Delaware corporation, et al.,</b>	)	<b>Jointly Administered</b>
	)	<b>Case No. 02-11573 (PJW)</b>
	)	
<b>Debtors.</b>	)	
<hr/>		

**ORDER REOPENING CHAPTER 11 CASE AND  
ENFORCING SALE ORDER**

Upon the motion (the "Motion")<sup>1</sup> of Roxio, Inc. ("Roxio") and Napster, LLC, by and through their undersigned counsel, hereby move the Court, for the entry of an order pursuant to sections 105, 350(b) and 363 of title 11 of the United States Code and Rule 3020(d) of the Federal Rules of Bankruptcy Procedure (the "Bankruptcy Rules") reopening the chapter 11 cases of Enco Recovery Corp. (f/k/a/ Napster, Inc.), Enco-2 Recovery Corp. (f/k/a Napster Music Company, Inc.) and Enco-3 Recovery Corp. (f/k/a Napster Mobile Company, Inc.) (collectively, the "Debtors") and enforcing the Court's Order Under 11 U.S.C. §§ 105(a), 363, 365 and 1146(c), and Fed. R. Bankr. P. 2002, 6004, 6006, and 9014 (A) Approving Asset Purchase Agreement; (B) Authorizing the Sale of Substantially All of Debtors' Assets; (C) Authorizing Assumption and Assignment of Certain Executory Contract; and (D) Granting Other Related Relief (the "Sale Order"); the Court having reviewed the Motion, and having heard the statements of counsel regarding the Motion at a hearing before the Court (the "Hearing"); and the Court finding that (i) the Court has jurisdiction over this matter pursuant to 28 U.S.C. §§ 157 and 1334, (ii) this is a core proceeding pursuant to 28 U.S.C. § 157(b)(2); and (iii) that notice of this Motion and the Hearing was sufficient and that no other or further notice need be provided; and the Court having determined that the legal and factual basis set forth in the Motion establish

---

<sup>1</sup> Capitalized terms used but not defined herein shall have the meaning assigned to them in the Motion.

just cause for the relief granted herein; and the Court and after due deliberation and sufficient cause appearing therefor,

IT IS HEREBY FOUND AND DETERMINED THAT:<sup>2</sup>

A. Pursuant to the Sale Order, the Court approved that certain Asset Purchase Agreement dated as of November 15, 2002 between Napster, Inc., Napster Music Company, Inc., Napster Mobile Company, Inc. and Roxio, Inc. (the “Asset Purchase Agreement”) and the transactions contemplated by the Asset Purchase Agreement.

B. Pursuant to the Sale Order and Asset Purchase Agreement, Roxio validly acquired the Napster Assets and the goodwill associated with them, which constituted the core of the Debtors’ on-line services and related technology.

C. Pursuant to the Sale Order and Asset Purchase Agreement, Roxio validly acquired the Debtors’ trademarks, trademark registrations and pending applications for registration, including (i) United States Trademark Registration No. 2575170 for the mark NAPSTER, registered on the Principal Register of the United States Trademark Office on June 4, 2002 (the “NAPSTER Registration”) and (ii) three then-pending Intent-to-Use applications that Napster, Inc. had filed with the United States Trademark Office (the “NAPSTER ITU Applications”) which subsequently ripened into United States Trademark Registration Nos. 2841431, 2843786 and 2843405.

D. Pursuant to the Sale Order and Asset Purchase Agreement, Roxio validly acquired the goodwill associated with the NAPSTER Registration and NAPSTER ITU Applications.

E. Pursuant to the Sale Order and Asset Purchase Agreement, Roxio validly acquired the right to represent to third parties that it was the successor to the Debtors’ business.

F. In the Sale Order, the Court found and ordered that the transfer of the Napster Assets to Roxio pursuant to the Asset Purchase Agreement constituted a legal, valid, and

---

<sup>2</sup> Findings of fact shall be construed as conclusions of law and conclusions of law shall be construed as findings of fact when appropriate. See Fed. R. Bankr. P. 7052.

effective transfer of the Napster Assets, and vested Roxio with all right, title, and interest of the Debtors in and to the Napster Assets.

G. SightSound Technologies, Inc. (“SightSound”) has filed a petition (the “Petition”) with the United States Trademark Trial and Appeal Board (“TTAB”) seeking the cancellation of the NAPSTER Registration and the registrations upon which the NAPSTER ITU Applications.

H. By filing the Petition and seeking cancellation of the NAPSTER Registration and the registrations upon which the NAPSTER ITU Applications on the grounds set forth in the Petition, SightSound seeks to undermine the effectiveness of the Sale Order, the Asset Purchase Agreement and the validity of the transfer of the Napster Assets, including the NAPSTER Registration and the NAPSTER ITU Applications along with their associated goodwill, to Roxio.

NOW, THEREFORE, IT IS HEREBY ORDERED THAT:

1. The Motion is GRANTED.
2. The Debtors’ bankruptcy case is hereby reopened pursuant to 11 U.S.C. § 350(b) for the purpose of granting the relief set forth herein.
3. SightSound shall cease all further prosecution of the Petition in the TTAB and shall not commence, continue, pursue or prosecute any action or proceeding in any court or tribunal that asserts that the Napster Assets, including the NAPSTER Registration and the NAPSTER ITU Applications and their associated goodwill, were not validly transferred to Roxio or that otherwise seeks any relief that would impair the rights granted to Roxio in the Sale order and in the Asset Purchase Agreement.

4. This Court retains jurisdiction with respect to all matters arising from or related to the interpretation and enforcement of this Order.

Dated: \_\_\_\_\_, 2005  
Wilmington, Delaware

---

The Honorable Peter J. Walsh  
United States Bankruptcy Judge

**CERTIFICATE OF SERVICE**

I, Michael J. Merchant, do hereby certify that on May 19, 2005, I caused copies of the foregoing *Motion to Reopen Chapter 11 Case and Enforce Sale Order* to be served upon the following service list in the manner indicated thereon.

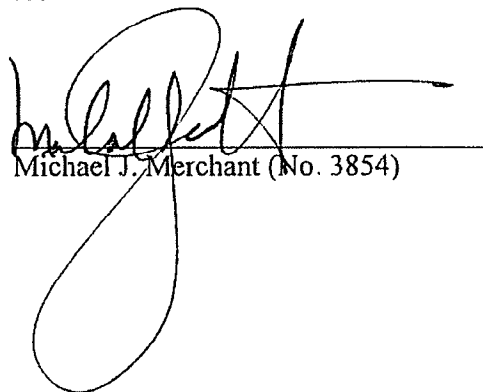

Michael J. Merchant (No. 3854)

**Napster, Inc., Case No. 02-11573 (PJW)**  
**Bankruptcy Rule 2002 Service List**

**Via Hand Delivery**

David L. Buchbinder  
Office of the United States Trustee  
844 King Street, Suite 2313  
Lockbox 35  
Wilmington, DE 19801

Ellen W. Slights  
U.S. Attorney's Office  
1201 Market Street, Suite 1100  
P.O. Box 2046  
Wilmington, DE 19899-2046

Randy R. Weller  
Attn: Division of Revenue  
MS #25  
8th Floor  
State of Delaware  
820 N. French Street  
Wilmington, DE 19801-0820

Brendan L. Shannon  
Young Conaway Stargatt & Taylor, LLP  
1000 West Street, 17th Floor  
P.O. Box 391  
Wilmington, DE 19899-0391

William E. Chipman  
Scott D. Cousins  
Scott Salerni  
Greenberg Traurig, LLP  
The Brandywine Building  
1000 West Street, Suite 1540  
Wilmington, DE 19801

William P. Bowden  
Ashby & Geddes  
222 Delaware Ave., 17th Floor  
P.O. Box 1150  
Wilmington, DE 19899

Brian A. Sullivan  
Werb & Sullivan  
300 Delaware Avenue  
Wilmington, DE 19801

Jami B. Nimeroff  
Buchanan Ingersoll P.C.  
1201 N. Market Street  
Ste. 1501  
Wilmington, DE 19801

David B. Stratton  
Pepper Hamilton LLP  
1313 Market Street, Suite 1500  
Wilmington, DE 19899-1709

Francis A. Monaco, Jr.  
Walsh Monzack and Monaco, PA  
1201 North Orange Street, Suite 400  
Wilmington, DE 19801

Richard W. Riley  
Duane Morris LLP  
1100 North Market St. Suite 1200  
Wilmington, DE 19801

Mark Minuti  
Saul Ewing LLP  
222 Delaware Avenue, Ste 1200  
Wilmington, DE 19801

**Via First Class Mail**

Jintana Holliday  
Bank of America #5693  
1850 Gateway Blvd, 3rd Floor  
Concord, CA 94520

Joan McEwin  
Credit Inquiry Services WAI-501-23-01  
Bank of America  
P.O. Box 34893  
Seattle, WA 98124-1893

La-Yona C. Rauls  
Corporate Treasury CA5-701-05-51  
Bank of America  
1455 Market Street  
San Francisco, CA 94103

Judy H. Lee  
Global Money Transfer Service CA5-704-11-01  
Bank of America  
315 Montgomery Street, 11th Floor  
San Francisco, CA 94103

Janet Van Horn  
Comerica Bank  
5 Palo Alto Square, Ste. 800  
3000 El Camino Real  
Palo Alto, CA 94306

Jonathan Schwartz  
Carolyn Jensen  
Napster, Inc.  
600 Chesapeake Drive  
Redwood City, CA 94063

Representing Debtors  
Michelle Morgan Harner  
Jones, Day, Reavis & Pogue  
77 West Wacker  
Chicago, IL 60601

Representing Debtors  
Todd Brown  
Jones, Day, Reavis & Pogue  
51 Louisiana Ave., N.W.  
Washington, DC 20001

Representing Debtors  
Richard Cieri  
Adam D. Munson  
Jones, Day, Reavis & Pogue  
901 Lakeside Ave.  
Cleveland, OH 44114

Robert Levine  
Davis, Polk & Wardwell  
450 Lexington Avenue  
New York, NY 10017

Anthony Gosse  
JP Morgan Chase  
One Chase Manhattan Plaza, 7th Floor  
New York, NY 10081

Victor Nigro  
JP Morgan Chase  
One Chase Manhattan Plaza, 7th Floor  
New York, NY 10005

Debra Lane  
Branch Manager - Redwood City  
CAS-101-01-01  
Bank of America  
700 Jefferson Avenue  
Redwood City, CA 94063

Rick B. Antonoff  
Greenberg Traurig, LLP  
200 Park Avenue  
New York, NY 10166

Member of Official Committee of Unsecured  
Creditors  
Karen Caudill Dyer  
George R. Coe  
Boies, Schiller & Flexner LLP  
225 South Orange Ave., Ste. 905  
Orlando, FL 32801-3456

Member of Official Committee of Unsecured  
Creditors  
William J. Hanlon  
Schnader Harrison Goldstein & Manello  
265 Franklin Street  
Boston, MA 02110

Member of Official Committee of Unsecured  
Creditors  
Anna Borden  
Integrated Archive Systems, Inc.  
6700 Koll Center Parkway, Suite 140  
Pleasanton, CA 94566

Member of Official Committee of Unsecured  
Creditors

Thomas Schlegel  
Edel Music AG  
22607 Hamberg Wichmannstrasse4  
Haus 2 Germany,

Member of Official Unsecured Creditors  
Committee

Hadley Feldman  
Metromedia Fiber Network, Inc.  
360 Hamilton Avenue  
White Plains, NY 10601

Representing Metromedia Fiber Network, Inc.

Daren R. Brinkman  
Brinkman & Associates  
800 Wilshire Blvd., Ste. 950  
Los Angeles, CA 90017SS

Arni Sigurdsson  
Digital World Services  
1540 Broadway, 29th Floor  
New York, NY 10036

Joel Weinstein  
Epstein, Levinsohn, Bodine, Hurwitz &  
Weinstein LLP  
1790 Broadway, 10th Floor  
New York, NY 10019

Brian Litman  
PlayMedia Systems, Inc.  
8170 S. Eastern Avenue, Suite 4601  
Las Vegas, NV 89123-2579

Elain McCreedy  
Portal Software, Inc.  
10200 South De Anza Blvd  
Cupertino, CA 95014

John Buono  
Oracle Corporation  
P. O. Box 44471  
San Francisco, CA 94144-4471

KPMG, LLP  
355 South Grand Avenue  
Suite 2000  
Los Angeles, CA 90071-1568

Alison Wenham  
CEO  
Lamb House Church Street  
London W4 2, PD

Robert Silver  
Boies, Schiller & Flexner LLP  
80 Business Park Drive  
Armonk, NY 10504

Steven Holtzman  
Boies, Schiller & Flexner LLP  
1999 Harrison Street, Suite 900  
Oakland, CA 94612

Jason Matrins  
AEC One Stop Group, Inc.  
4250 Coral Ridge Drive  
Coral Springs, FL 33065

Venables, Bell & Partners, LLC  
Attn: Laura/Accounting  
717 California Street  
San Francisco, CA 94108

Kana Software, Inc.  
Attn: Leslie  
File No. 74023  
P.O. Box 60000  
San Francisco, CA 94106

MPRM, LLC  
Attn: Betty  
5670 Wilshire Blvd. 25th Floor  
Los Angeles, CA 90036

Michael Wolfe  
Cranell, Inc.  
8999 Gemini Parkway  
Columbus, OH 43240



Softchoice Corporation  
Attn: Accounting  
P. O. Box 33018  
Detroit, MI 48232-5018

Tommy Means  
Complete Pandemonium, LLC  
255 Kansas Street  
San Francisco, CA 94103

Relatable, LLC  
Attn: Patrick  
30 South Quaker Lane, 3rd Floor  
Alexandria, VA 22314

Icon Microsystems, Inc.  
Attn: Dan  
46750 Fremont Blvd., Suite 101  
Fremont, CA 94538

Mark Hanson  
CAT Technology  
505 Sansome Street, Suite 150  
San Francisco, CA 94111

DHL Worldwide Express  
P.O. Box 78016  
Phoenix, AZ 85040

Delaware Secretary of State  
Division of Corporations  
Attn: Franchise Tax Division  
P.O. Box 7040  
Dover, DE 19903

Secretary of the Treasury  
P.O. Box 7040  
Dover, DE 19903

Internal Revenue Service  
Attn: District Director  
409 Silverside Road  
Wilmington, DE 19809

Nathan Fuchs  
Securities and Exchange Commission  
New York Regional Office  
233 Broadway  
New York, NY 10279

Securities and Exchange Commission  
15th and Pennsylvania Avenue, N.W.  
Washington, DC 20020

Representing Openwave Systems, Inc.  
Julie H. Rome-Banks  
Binder & Malter LLP  
2775 Park Avenue  
Santa Clara, CA 95050

Carla Florian  
Openwave Systems, Inc.  
1400 Seaport Blvd.  
Redwood City, CA 94063

Joseph A. Eisenberg  
Jeffer, Mangels, Butler & Marmaro LLP  
2121 Avenue of the Stars, 10th Floor  
Los Angeles, CA 90067

Ana N. Damonte  
M. David Minnick  
Pillsbury Winthrop LLP  
50 Fremont Street  
P.O. Box 7880  
San Francisco, CA 94120-7880

Representing the Association of Independent  
Music  
Charlene D. Davis  
The Bayard Firm  
222 Delaware Ave., Suite 900  
Wilmington, DE 19801

Representing the National Music Publishers' Association, Inc.  
Andrew N. Rosenberg  
Paul, Weiss, Rifkind, Wharton & Garrison  
1285 Avenue of the Americas  
New York, NY 10019-6064

Representing Comerica Bank-California  
Susan P. Persichilli  
Buchanan Ingersoll P.C.  
140 Broadway, 35th Floor  
New York, NY 10005

Representing Comerica Bank-California  
Jami B. Nimeroff  
Buchanan Ingersoll P.C.  
1201 N. Market St., Ste. 1501  
Wilmington, DE 19801

IOS Capital, LLC  
Bankruptcy Administration  
1738 Bass Road  
P.O. Box 13708  
Macon, GA 31208-3708

David B. Stratton  
Pepper Hamilton LLP  
1201 Market Street, Suite 1600  
Representing PlayMedia Systems, Inc.  
Richard W. Riley  
Duane Morris LLP  
1100 North Market St., Suite 1200  
Wilmington, DE 19801

Traci Fette  
DACA V, LLC  
2120 W. Washington Street  
San Diego, CA 92110

Andrew Lee  
11301 West Olympic Blvd., #530  
Los Angeles, CA 90064

Mark Minuti  
Saul Ewing LLP  
222 Delaware Ave., Ste. 1200  
Wilmington, DE 1266

P.O. Box 1709  
Wilmington, DE 19899-1709

Representing Sunrise International Leasing  
Brian L. Boysen  
Kurt M. Anderson, Attorney At Law  
5010 IDS Center  
80 South 8th Street  
Minneapolis, MN 55402

Representing Hamstein Music Publishing  
James R. Sterling  
Lavelly & Singer  
2049 Century Park East, Suite 2400  
Los Angeles, CA 90067-2906

Elliot H. Herskowitz  
Regen Capital I, Inc.  
2109 Broadway, Suite 206  
New York, NY 10023

Dorian Daley  
Oracle Corporation  
500 Oracle Parkway  
Mail Stop 50p7  
Redwood City, CA 94065

Hobart G. Truesdell  
Walker, Truesdell, Radick & Associates  
380 Lexington Avenue, Suite 1514  
New York, NY 10168

Counsel for the Chapter 11 Trustee  
John R. Hemphill  
Morrison & Forester, LLP  
1290 Avenue of the Americas  
New York, NY 10104

Suzanne Uhland  
O'Melveny & Myers LLP  
610 Newport Center Drive, 17th Floor  
Newport Beach, CA 92660

Craig Freeman  
Thelen Reid & Priest LLP  
875 Third Avenue  
New York, NY 10022

Sightsound Technologies Inc.  
311 South Craig Street  
Suite 205  
Pittsburg, PA 15213

Robert Levine  
Davis, Polk & Wardwell  
450 Lexington Avenue  
New York, NY 10017

Deborah Ballati  
Farella Braun & Martel LLP  
The Russ Building  
235 Montgomery Street  
San Francisco, CA 94104

Jeff Levenberg  
Director of Business Affairs  
Rawkus Records  
676 Broadway, 4th Floor  
New York, NY 10012

Carlos Gracia  
AboveNet Communications, Inc.  
50 W. San Fernando St., Suite #1010  
San Jose, CA 95113

Terri Durham  
Emusic.com Inc.  
4790 Eastgate Mall  
San Diego, CA 92121-1970

William K. Wells  
Brian S. Mudge  
Susan A. Smith  
KENYON & KENYON  
1500 K Street, N.W., Suite 700  
Washington, DC 20005

**EXHIBIT 4**

IN THE UNITED STATES DISTRICT COURT  
FOR THE WESTERN DISTRICT OF PENNSYLVANIA

SIGHTSOUND TECHNOLOGIES, INC.,	)	
a Delaware corporation,	)	
	)	
Plaintiff,	)	
	)	
v.	)	Civil Action No. _____
	)	
ROXIO, INC.,	)	JURY TRIAL DEMANDED
a Delaware corporation,	)	
	)	
-and -	)	
	)	
NAPSTER, L.L.C.,	)	
a Delaware limited liability company)	)	
	)	
Defendants.	)	
_____	)	

**COMPLAINT**

Plaintiff SightSound Technologies, Inc. (“SightSound”), by its attorneys, Meyer, Unkovic & Scott LLP, and Kenyon & Kenyon, brings this civil action for patent infringement against Defendants Roxio, Inc. and Napster, L.L.C., and in support thereof alleges as follows:

**Parties**

1. SightSound is a corporation organized and existing under the laws of the State of Delaware, with its principal place of business at 733 Washington Road, Suite 400, Mount Lebanon, Pennsylvania 15228.

2. Defendant, Roxio, Inc. (“Roxio”), is a corporation organized and existing under the laws of the State of Delaware, with its principal place of business at 455 El Camino Real, Santa Clara, California, 95050.

3. Defendant, Napster, L.L.C. is a limited liability company organized and existing under the laws of the State of Delaware, with its principal place of business at 9044 Melrose Ave., Los Angeles, California, 90069.

4. On information and belief, Roxio has acquired certain assets from Napster, Inc., Napster Music Company, Inc., Napster Mobile Company, Inc, and Pressplay, Inc., including the business of selling digital music electronically.

5. On information and belief, Roxio and Napster, L.L.C. (Roxio and Napster, L.L.C. are collectively referred to herein as "Napster"), working individually and/or together in conjunction, are involved in the electronic sale, and transmission of digital music throughout the United States, including in the Commonwealth of Pennsylvania.

#### **Jurisdiction**

6. This Court has jurisdiction over the subject matter of this action under 28 U.S.C. § 1331 and 1338(a).

#### **Venue**

7. Venue is proper in this Court under the provisions of 28 U.S.C. § 1391(c) and 28 U.S.C. § 1400(b).

#### **General Facts**

8. Arthur R. Hair ("Hair") is the inventor to whom the United States Patent Office issued United States Patent No. 5,191,573 on March 2, 1993 (hereinafter the "'573 Patent"). A true and correct copy of the '573 Patent is attached hereto as Exhibit "A".

9. SightSound is the assignee of the rights, title and interest in the '573 Patent issued to Hair.

10. Hair is the inventor and SightSound is the assignee to whom the United States Patent Office issued United States Patent No. 5,675,734 on October 7, 1997 (hereinafter the "'734 Patent"). A true and correct copy of the '734 Patent is attached hereto as Exhibit "B".

11. The '734 Patent is a continuation of the application that led to the '573 Patent.

12. Hair is the inventor and SightSound is the assignee to whom the United States Patent Office issued United States Patent No. 5,966,440 on October 12, 1999 (hereinafter the "'440 Patent"). A true and correct copy of the '440 Patent is attached hereto as Exhibit "C".

13. The '440 Patent is a continuation of the application that led to the '573 Patent.

14. On January 16, 1998, SightSound filed a patent infringement action against N2K, Inc. ("N2K"), for infringement of the '573 Patent, and the '734 Patent in the United States District Court for the Western District of Pennsylvania, Civil Action No. 98-0118. In March, 2000, SightSound joined CDnow, Inc., and CDnow Online Inc. (collectively "CDnow"), as defendants in that lawsuit and added a claim of infringement of the '440 Patent against all defendants.

15. In the lawsuit against CDnow and N2K, this Court held a Markman hearing and issued an order on construction of relevant terms of the claims of the patents in suit. Subsequently, a motion for summary judgment filed by N2K and CDnow alleging invalidity of the '573 Patent, the '734 Patent, and the '440 Patent, was denied. SightSound's motion for summary judgment was granted, dismissing allegations by N2K and CDnow that SightSound had committed inequitable conduct.

16. Pursuant to a settlement agreement among the parties, CDnow and N2K agreed to a Final Judgment and Order on Consent, entered by this Court on February 20, 2004, that the '573 Patent, the '734 Patent, and the '440 Patent are valid and enforceable.

## COUNT I

### Patent Infringement

17. Paragraphs 1-16, inclusive, above, are hereby incorporated herein by reference.

18. Napster has been making and continues to make and/or has sold and continues to sell and/or continues to induce others to sell and/or use and/or contribute to the making, using or selling of one or more digital audio signals for or with systems and/or processes within the scope of the claims of the '573 Patent in this judicial district and elsewhere in the United States.

19. Napster has notice of the '573 Patent, pursuant to 35 U.S.C. § 287, prior to the commencement of this civil action.

20. The unauthorized making, use, or sale of such digital audio signals by Napster infringes the '573 Patent.

21. Napster is a direct and/or contributory infringer of the '573 Patent, and/or has induced infringement of the '573 Patent by others in violation of 35 U.S.C. § 271.

22. Unless enjoined by this Court, Napster will continue to infringe the '573 Patent in the future.

23. On information and belief, Napster has infringed and is infringing the '573 Patent, with full knowledge of the '573 Patent, and the infringement has been willful and deliberate and continues to be willful and deliberate. This case is exceptional under 35 U.S.C. § 285.

## COUNT II

24. Paragraphs 1-23, inclusive, above, are hereby incorporated herein by reference.



25. Napster has been making and continues to make and/or has sold and continues to sell and/or continues to induce others to sell and/or use and/or contribute to the making, using or selling of one or more digital audio signals for or with processes within the scope of the claims of the '734 Patent in this judicial district and elsewhere in the United States.

26. Napster has received notice of the '734 Patent pursuant to 35 U.S.C. § 287, prior to the commencement of this civil action.

27. The unauthorized making, use, or sale of such a digital audio signal by Napster infringes the '734 Patent.

28. Napster is a direct and/or contributory infringer of the '734 Patent and/or has induced infringement of the '734 Patent by others in violation of 35 U.S.C. § 271.

29. Unless enjoined by this Court, Napster will continue to infringe the '734 Patent in the future.

30. On information and belief, Napster has infringed and is infringing the '734 Patent with full knowledge of the '734 Patent, and the infringement has been willful and deliberate and continues to be willful and deliberate. This case is exceptional under 35 U.S.C. § 285.

### COUNT III

31. Paragraphs 1-30, inclusive, above, are hereby incorporated herein by reference.

32. Napster has been making and continues to make and/or has sold and continues to sell and/or continues to induce others to sell and/or use and/or contribute to the making, using or selling of one or more digital audio signals for or with processes within the scope of the claims of the '440 Patent in this judicial district and elsewhere in the United States.

33. Napster has received notice of the '440 Patent pursuant to 35 U.S.C. § 287, prior to the commencement of this civil action.

34. The unauthorized making, use, or sale of such a digital audio signal by Napster infringes the '440 Patent.

35. Napster is a direct and/or contributory infringer of the '440 Patent and/or has induced infringement of the '440 Patent by others in violation of 35 U.S.C. § 271.

36. Unless enjoined by this Court, Napster will continue to infringe the '440 Patent in the future.

37. On information and belief, Napster has infringed and is infringing the '440 Patent, with full knowledge of the '440 Patent, and the infringement has been willful and deliberate and continues to be willful and deliberate. This case is exceptional under 35 U.S.C. § 285.

#### **PRAYER FOR RELIEF**

WHEREFORE, Plaintiff Sightsound Technologies, Inc. demands judgment in its favor and against Napster, as follows:

A. That this Court adjudge and decree that United States Patent No. 5,191,573, United States Patent No. 5,675,734, and United States Patent No. 5,966,440 are valid and enforceable against Napster;

B. That this Court adjudge and decree that Napster has infringed the '573 Patent, the '734 Patent, and the '440 Patent;

C. That this Court preliminarily and permanently enjoin Napster, its officers, directors, agents, employees, servants, attorneys, successors, assigns and all others controlling, controlled by, affiliated with or in privity with Napster, from committing further acts of infringement of the '573 Patent, the '734 Patent, and the '440 Patent, pursuant to 35 U.S.C. § 283;

D. That this Court direct Napster to file with this Court and serve on counsel for Sightsound, within thirty (30) days of the entry of said injunction, a report in writing

under oath setting forth in detail the manner and form in which Napster has complied with the injunction;

E. That this Court award damages sufficient to compensate Sightsound for the infringement of the '573 Patent, the '734 Patent, and the '440 Patent by Napster, pursuant to 35 U.S.C. § 284, together with costs and prejudgment interest for the amount of damages determined;

F. That this Court increase such damages up to three (3) times the amount found or assessed in view of the willful and deliberate character of such infringement of said patents by Napster, pursuant to 35 U.S.C. § 284;

G. That this Court find this case "exceptional" and award Sightsound its reasonable attorneys' fees, pursuant to 35 U.S.C. § 285; and

H. That this Court award Sightsound such other and further relief as the Court may deem just and proper.

**PLAINTIFF DEMANDS A JURY TRIAL**

By: Richard F. Rinaldo, esq  
Richard F. Rinaldo, Esquire  
Pa. I.D. No. 33222

MEYER, UNKOVIC & SCOTT LLP  
1300 Oliver Building  
Pittsburgh, PA 15222  
(412) 456-2800

*William K. Wells, DC Bar No. 949685*  
*Brian S. Mudge, Pa. I.D. No. 62607*  
KENYON & KENYON  
1500 K Street, NW, Suite 700  
Washington, DC 20005  
(202) 220-4200

ATTORNEYS FOR PLAINTIFF SIGHTSOUND.COM, INC.

# **Exhibit A**



US005191573A

# United States Patent [19]

Hair

[11] Patent Number: 5,191,573

[45] Date of Patent: Mar. 2, 1993

[54] METHOD FOR TRANSMITTING A DESIRED DIGITAL VIDEO OR AUDIO SIGNAL

[76] Inventor: Arthur R. Hair, 301 Oaklawn Dr., Pittsburgh, Pa. 15241

[21] Appl. No.: 586,391

[22] Filed: Sep. 18, 1990

### Related U.S. Application Data

[63] Continuation of Ser. No. 206,497, Jun. 13, 1988, abandoned.

[51] Int. Cl.<sup>5</sup> ..... G11B 5/06; G11B 7/00; G11B 11/00

[52] U.S. Cl. .... 369/84; 235/381; 235/380; 369/33; 369/34; 369/15; 369/85

[58] Field of Search ..... 369/33, 34, 13, 15, 369/84, 85; 235/380, 381, 375; 364/479, 410

### [56] References Cited

#### U.S. PATENT DOCUMENTS

3,718,906	2/1973	Lightner	235/381
3,990,710	11/1976	Hughes	369/34
4,567,359	1/1986	Lockwood	235/381
4,647,989	3/1987	Geddes	235/381

4,654,799 3/1987 Ogaki et al. .... 364/479

Primary Examiner—Hoa Nguyen  
Attorney, Agent, or Firm—Ansel M. Schwartz

### [57] ABSTRACT

The present invention is a method for transmitting a desired digital video or audio signal stored on a first memory of a first party to a second memory of a second party. The method comprises the steps of transferring money via a telecommunications line to the first party from the second party. Additionally, the method comprises the step of then connecting electronically via a telecommunications line the first memory with the second memory such that the desired signal can pass therebetween. Next, there is the step of transmitting the desired digital signal from the first memory with a transmitter in control and in possession of the first party to a receiver having the second memory at a location determined by the second party. The receiver is in possession and in control of the second party. There is also the step of then storing the digital signal in the second memory.

6 Claims, 2 Drawing Sheets

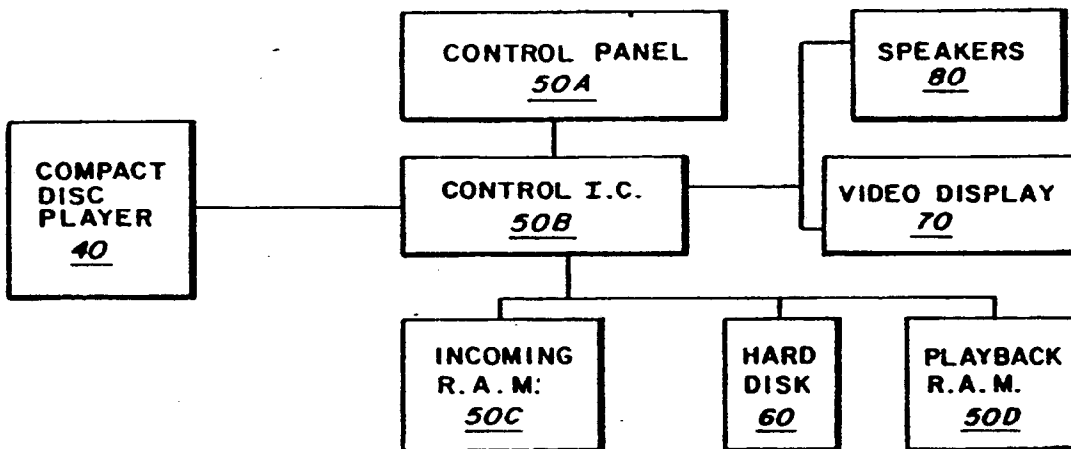

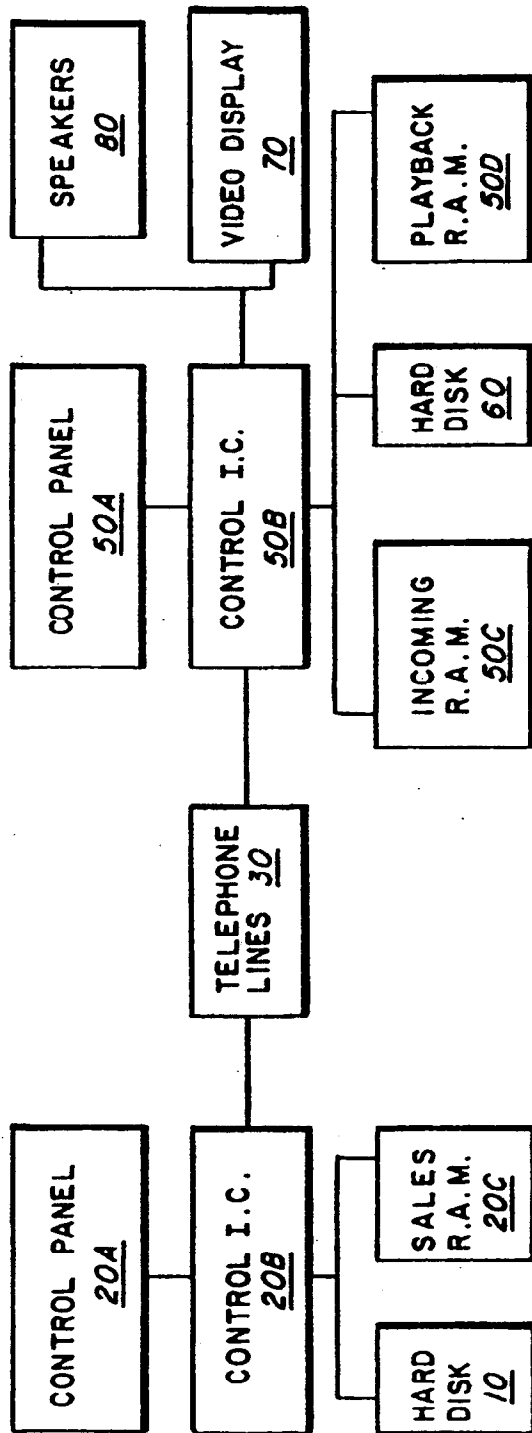

FIG. 1

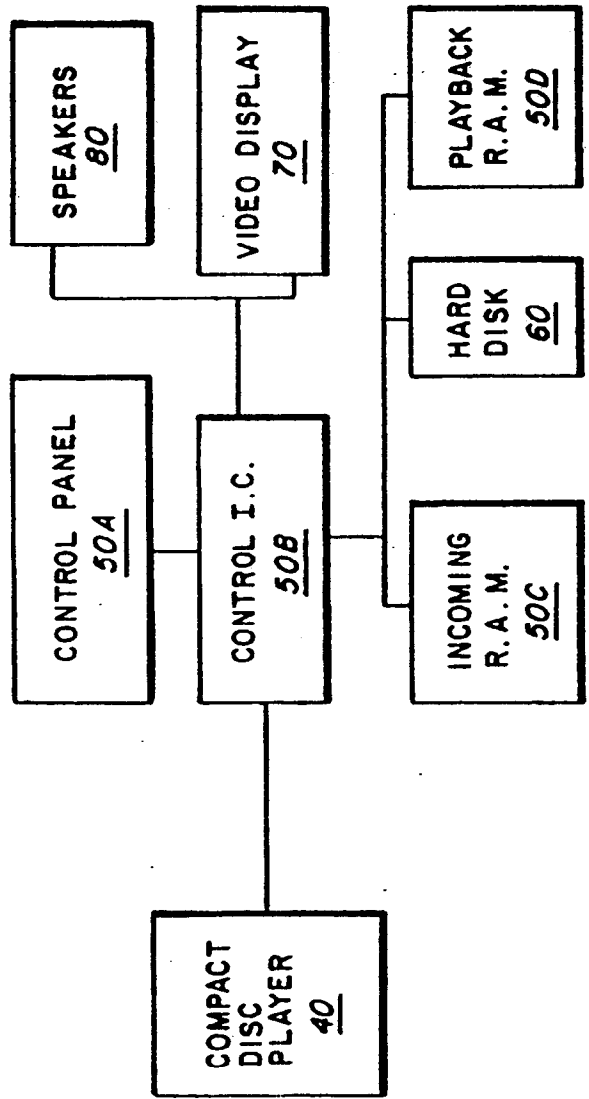

FIG. 2

## METHOD FOR TRANSMITTING A DESIRED DIGITAL VIDEO OR AUDIO SIGNAL

This is a continuation of copending application Ser. No. 07/206,497 filed on Jun. 13, 1988, now abandoned.

### FIELD OF THE INVENTION

The present invention is related to a method for the electronic sales and distribution of digital audio or video signals, and more particularly, to a method which a user may purchase and receive digital audio or video signal from any location which the user has access to a telecommunications line.

### BACKGROUND OF THE INVENTION

The three basic mediums (hardware units) of music: records, tapes, and compact discs, greatly restricts the transferability of music and results in a variety of inefficiencies.

**CAPACITY:** The individual hardware units as cited above are limited as to the amount of music that can be stored on each.

**MATERIALS:** The materials used to manufacture the hardware units are subject to damage and deterioration during normal operations, handling, and exposure to the elements.

**SIZE:** The physical size of the hardware units imposes constraints on the quantity of hardware units which can be housed for playback in confined areas such as in automobiles, boats, planes, etc.

**RETRIEVAL:** Hardware units limit the ability to play, in a sequence selected by the user, songs from different albums. For example, if the user wants to play one song from ten different albums, the user would spend an inordinate amount of time handling, sorting, and cueing the ten different hardware units.

**SALES AND DISTRIBUTION:** Prior to final purchase, hardware units need to be physically transferred from the manufacturing facility to the wholesale warehouse to the retail warehouse to the retail outlet, resulting in lengthy, lag time between music creation and music marketing, as well as incurring unnecessary and inefficient transfer and handling costs. Additionally, tooling costs required for mass production of the hardware units and the material cost of the hardware units themselves, further drives up the cost of music to the end user.

**QUALITY:** Until the recent invention of Digital Audio Music, as used on Compact Discs, distortion free transfer from the hardware units to the stereo system was virtually impossible. Digital Audio Music is simply music converted into a very basic computer language known as binary. A series of commands known as zeros or ones encode the music for future playback. Use of laser retrieval of the binary commands results in distortion free transfer of the music from the compact disc to the stereo system. Quality Digital Audio Music is defined as the binary structure of the Digital Audio Music. Conventional analog tape recording of Digital Audio Music is not to be considered quality inasmuch as the binary structure itself is not recorded. While Digital Audio Music on compact discs is a technological breakthrough in audio quality, the method by which the music is sold, distributed, stored, manipulated, retrieved, played and protected from copyright infringements remains as inefficient as with records and tapes.

**COPYRIGHT PROTECTION:** Since the invention of tape recording devices, strict control and enforcement of copyright laws have proved difficult and impossible with home recorders. Additionally, the recent invention of Digital Audio Tape Recorders now jeopardizes the electronic copyright protection of quality Digital Audio Music on Compact Discs or Digital Audio Tapes. If music exists on hardware units, it can be copied.

Accordingly, it is an objective of this invention is to provide a new and improved methodology/system to electronically sell and distribute Digital Audio Music.

A further objective of this invention to provide a new and improved methodology/system to electronically store and retrieve Digital Audio Music.

Another objective of this invention is to provide a new and improved methodology/system to electronically manipulate, i.e., sort, cue, and select, Digital Audio Music for playback.

Still another objective of this invention is to offer a new and improved methodology/system which can prevent unauthorized electronic copying of quality Digital Audio Music.

### SUMMARY OF THE INVENTION

Briefly, this invention accomplishes the above cited objectives by providing a new and improved methodology/system of electronic sales, distribution, storage, manipulation, retrieval, playback, and copyright protection of Digital Audio Music. The high speed transfer of Digital Audio Music as prescribed by this invention is stored onto one piece of hardware, a hard disk, thus eliminating the need to unnecessarily handle records, tapes, or compact discs on a regular basis. This invention recalls stored music for playback as selected/programmed by the user. This invention can easily and electronically sort stored music based on many different criteria such as, but not limited to, music category, artist, album, user's favorite songs, etc. An additional feature of this invention is the random playback of songs, also based on the user's selection. For example, the user could have this invention randomly play all jazz songs stored on the user's hard disk, or randomly play all songs by a certain artist, or randomly play all of the user's favorite songs which the user previously electronically "tagged" as favorites. Further, being more specific, the user can electronically select a series of individual songs from different albums for sequential playback.

This invention can be configured to either accept direct input of Digital Audio Music from the digital output of a Compact Disc, such transfer would be performed by the private user, or this invention can be configured to accept Digital Audio Music from a source authorized by the copyright holder to sell and distribute the copyrighted materials, thus guaranteeing the protection of such copyrighted materials. Either method of electronically transferring Digital Audio Music by means of this invention is intended to comply with all copyright laws and restrictions and any such transfer is subject to the appropriate authorization by the copyright holder. Inasmuch as Digital Audio Music is software as this invention electronically transfers and stores such music, electronic sales and distribution of the music can take place via telephone lines onto a hard disk. This new methodology/system of music sales and distribution will greatly reduce the cost of goods sold