

IN THE UNITED STATES PATENT AND TRADEMARK OFFICE

In re Patent of: Stephen Barbour
U.S. Patent No.: 11/574,372 Attorney Docket No.: 54598-0001PS1
Issue Date: February 7, 2023
Appl. Serial No.: 16/484,728
Filing Date: January 6, 2020
Title: BLOCKCHAIN MINE AT OIL OR GAS FACILITY

DECLARATION OF VERNON KASDORF

I, Vernon Kasdorf, declare as follows:

I. ASSIGNMENT

1. I have been retained on behalf of Crusoe Energy Systems, LLC. (“Crusoe” or “Petitioner”) to offer technical opinions related to U.S. Patent No. 11/574,372 (“The ’372 patent”) (EX1001). I understand that Crusoe is requesting the Patent Trial and Appeal Board (“PTAB” or “Board”) to institute a post-grant review (“PGR”) proceeding of the ’372 patent.

2. I have been asked to provide my independent analysis of the ’372 patent in light of the prior art cited in this declaration. Crusoe has specifically asked for my analysis from the perspective of a POSITA in the bitcoin mining industry. To the extent this declaration provides opinions on subject matter related to the gas and oil industry, I am relying on the opinions of Dr. Michael Nikolau (EX1003). To that end, I am relying on Dr. Nikolau’s review and analysis of Dickerson, Belady, Boot, and the MAGS System – which are all identified as prior art herein.

3. I am not and never have been, an employee of Crusoe. I received no compensation for this declaration beyond my normal hourly compensation based on my time actually spent analyzing the ’372 patent, the prior art cited below, and issues related thereto, and I will not receive any added compensation based on the outcome of this PGR or other proceeding involving the ’372 patent.

II. QUALIFICATIONS

4. My name is Vernon Kasdorf. I am the CEO of KubeData Systems Inc. and have held that position since 2013.

5. I have a Bachelor’s Degree in business administration from Trinity Western University.

6. I have extensive experience in building industrial cryptocurrency mining data centers, including data centers for mining Bitcoin. I have over 25 years of experience in the IT

sector, with my career heavily focused on mining within the oil, gas, mineral, and cryptocurrency industries.

7. KubeData Systems Inc., my company, primarily, provides senior, strategic IT consulting services to mining companies, IoT companies, and large Enterprise organizations. I was also the owner and partner in KubeData Systems Inc. from 2013 to present.

8. My company developed and commercialized the CryptoKube mobile bitcoin miner system, to address the demand for an industrial cryptocurrency mining mobile data center. It was also our first 100% free-cooled data center. KubeData Systems Inc. designed and built three generations of CryptoKube mining data centers, servicing the Canadian and United States market.

9. I have provided IT Strategic Consulting to many companies, including Goldcorp (the world's largest gold miner).

10. I am fully familiar with the CryptoKube brochure dated March 5, 2016 ("CryptoKube brochure") and CryptoKube Bitcoin mining Data center tour(CC) ("CryptoKube video"). The CryptoKube brochure is EX1006, and the CryptoKube video is EX1007. I am able to authenticate both and declare that both the CryptoKube brochure and the CryptoKube video were published before February 8, 2017 – which I understand to be the earliest claimed priority date of the '372 patent.

11. I have personal knowledge that the CryptoKube brochure was originally published (distributed online, at trade show, and via emails to customers) in 2014 and the CryptoKube video was published on YouTube on December 18, 2014.

12. My curriculum vitae, which includes a complete list of my publications, is included as Appendix A.

13. I am being compensated at a rate of \$350 per hour for my work in this case. This

compensation is not contingent on the nature of my findings or the outcome of this litigation.

14. I am over the age of 18 and am competent to write this declaration. I have personal knowledge, or have developed knowledge, of the technologies discussed in this declaration based upon my education, training, or experience with the matters discussed herein.

III. SUMMARY OF CONCLUSIONS FORMED

15. This Declaration explains the conclusions that I have formed based on my analysis.

To summarize those conclusions:

- **Ground 1:** Based upon my knowledge and experience and my review of the prior art in this declaration, and Dr. Nikolaou's Declaration (EX1003), I believe that claims 1-4, 8, 16-30, and 34 of the '372 patent are rendered obvious by Dickerson and CryptoKube, in view of Szmigielski and Kheterpal.
- **Ground 2:** Based upon my knowledge and experience and my review of the prior art in this declaration, and Dr. Nikolaou's Declaration (EX1003), I believe that claims 1-4, 8, 10-12, 15-30, 34-37, and 40 of the '372 patent are rendered obvious by Dickerson, CryptoKube, and Belady-989, in view of Szmigielski and Kheterpal.
- **Ground 3:** Based upon my knowledge and experience and my review of the prior art in this declaration, and Dr. Nikolaou's Declaration (EX1003), I believe that claims 1-4, 7-12, 15-30, 34-37, and 40 of the '372 patent are rendered obvious by Dickerson, CryptoKube, Belady-989, and Boot, in view of Szmigielski and Kheterpal.
- **Ground 4:** Based upon my knowledge and experience and my review of the prior art in this declaration, and Dr. Nikolaou's Declaration (EX1003), I believe that claims 1-4, 8, 16-30, and 34 of the '372 patent are rendered obvious by Pioneer

Energy's MAGS system and the Polivka miner, in view Szmigielski and Kheterpal.

- **Ground 5:** Based upon my knowledge and experience and my review of the prior art in this declaration, and Dr. Nikolaou's Declaration (EX1003), I believe that claims 1-4, 8, 10-12, 15-30, 34-37, and 40 are rendered obvious by Pioneer Energy's MAGS system, the Polivka miner, and Belady-989, in view of Szmigielski and Kheterpal.

IV. PERSON OF ORDINARY SKILL IN THE ART

16. In my opinion, a person of ordinary skill in the art of the '372 patent would have a degree in chemical engineering, petroleum engineering, process engineering, mechanical engineering, or a similar field with 1-2 years of experience in designing power generation systems, Bitcoin mining systems, or other comparable hands-on experience. Alternatively, a person having 3-5 years of experience in the Bitcoin mining industry would also qualify as a POSITA. Additional education could substitute for professional experience, or vice versa.

V. LEGAL PRINCIPLES

17. I am not a lawyer and I will not provide any legal opinions in this PGR. Although I am not a lawyer, I have been advised that certain legal standards are to be applied by technical experts in forming opinions regarding the meaning and validity of patent claims.

A. Claim Construction

18. I understand that claim terms are generally given their plain and ordinary meaning in light of the patent's specification and file history as understood by a person of ordinary skill in the art at the time of the purported invention. In that regard, I understand that the best indicator of claim meaning is its usage in the context of the patent specification as understood by a POSITA. I further understand that the words of the claims should be given their plain meaning unless that meaning is inconsistent with the patent specification or the patent's history of examination before

the Patent Office. I also understand that the words of the claims should be interpreted as they would have been interpreted by a POSITA at the time of the invention was made (not today).

B. Obviousness

19. I understand that a patent claim is invalid if the claimed invention would have been obvious to a person of ordinary skill in the field at the time of the purported invention, which is often considered the time the application was filed. Thus, even if all of the claim limitations are not found in a single prior art reference that anticipates the claim, the claim can still be invalid. I also understand that a POSITA is presumed to have been aware of all pertinent prior art at the time of the alleged invention.

20. I understand that, to obtain a patent, a claimed invention must have, as of the priority date, been nonobvious in view of the prior art in the field. I understand that an invention is obvious when the differences between the subject matter sought to be patented and the prior art are such that the subject matter as a whole would have been obvious at the time the invention was made to a person having ordinary skill in the art.

21. I understand that, to prove that prior art or a combination of prior art renders a patent obvious it is necessary to: (1) identify the particular references that, singly or in combination, make the patent obvious; (2) specifically identify which elements of the patent claim appear in each of the asserted references; and (3) explain a motivation, teaching, need, market pressure or other legitimate reason that would have inspired a person of ordinary skill in the art to combine prior art references to solve a problem.

22. I also understand that certain objective indicia can be important evidence regarding whether a patent is obvious or nonobvious. Such indicia include:

- Commercial success of products covered by the patent claims;

- A long-felt need for the invention;
- Failed attempts by others to make the invention;
- Copying of the invention by others in the field;
- Unexpected results achieved by the invention as compared to the closest prior art;
- Praise of the invention by the infringer or others in the field;
- The taking of licenses under the patent by others;
- Expressions of surprise by experts and those skilled in the art at the making of the invention; and
- The patentee proceeded contrary to the accepted wisdom of the prior art.

23. To the extent these factors have been brought to my attention, if at all, I have taken them into consideration in rendering my opinions and conclusions. As discussed above and detailed in my curriculum vitae, I was very familiar with the bitcoin mining industry, bitcoin miner systems, cryptocurrency mining mobile data centers, and related equipment and technologies and was aware of the state of the art as of the earliest claimed priority date of the '372 patent. For the purposes of this declaration, I have been asked to assume that the earliest priority date of the '372 patent is February 8, 2017. I believe that I would qualify as understanding the knowledge and skill of a POSITA as of that date, and I have a sufficient level of knowledge, experience, and expertise to provide an expert opinion in the field of the '372 patent.

VI. MATERIALS CONSIDERED

24. In forming my opinion, I considered the following documents:

EX1001	U.S. Patent No. 11,574,372 to Stephen Barbour et al. (“the '372 Patent”)
EX1002	Excerpts from the Prosecution History of the '372 Patent (“the Prosecution History”)
EX1003	Declaration and Curriculum Vitae of Dr. Michael Nikolaou

EX1005	WO2015123257A1 (“Dickerson”)
EX1006	CryptoKube brochure from the WaybackMachine dated March 5, 2016 (“CryptoKube brochure”)
EX1007	CryptoKube Bitcoin mining Data center tour(CC) (“CryptoKube video”)
EX1008	CryptoKube Bitcoin mining Data center tour transcript
EX1009	Szmigielski, Albert. Bitcoin Essentials. Packt Publishing Ltd, 2016 (“Szmigielski”)
EX1010	U.S. Patent Publication No. 2016/0125040 (“Kheterpal”)
EX1011	PCT Patent Publication No. 2015/072989 (“Belady-989”)
EX1012	U.S. Patent No. 9,394,770 (“Boot”)
EX1013	Sanders, Gerald, and Johnson Space Center. "Gas Conversion Systems Reclaim Fuel for Industry." (“Sanders”)
EX1014	US Patent Publication No. 2015/0368566 (“Young”)
EX1015	Mining Container ~100kW by Polivka GmbH (“Bitcointalk forum post”)
EX1016	Mining with free natural gas r Bitcoin (“Reddit”)
EX1017	U.S. Patent Publication No. 2014/0096837 (“Belady-837”)
EX1018	U.S. Patent Publication No. 2018/0109541 (“Gleifchauf”)
EX1019	Polivka Mining Container Setup on Vimeo (“Polivka video”)
EX1020	Declaration of June Ann Munford
EX1021	U.S. Patent No. 6,161,386 (“Lokhandwala”)
EX1022	“Crypto you can mine from a home computer,” Brave New Coin (bravenewcoin.com) (July 18, 2023)
EX1023	CryptoKube Bitcoin mining Data center tour(CC) (“CryptoKube video-Part2”)
EX1100	Complaint for Patent Infringement, <i>Upstream Data Inc. v. Crusoe Energy Systems LLC</i> , Case No. 1:23-cv-01252 (D. Colo. May 18, 2023)

In addition to the documents and materials cited in this declaration, I also relied on my knowledge, education, skills, experience, and training in forming my opinions.

VII. BACKGROUND – BITCOIN/BLOCKCHAIN MINING

25. The following paragraphs regarding Bitcoin mining are based on prior art to the ’372 patent. As stated above, for the purposes of this declaration, I have been asked to assume that the earliest priority date of the ’372 patent is February 8, 2017.

26. The Bitcoin protocol defines a system in which the creation and distribution of the bitcoin cryptocurrency is governed by consensus among a peer-to-peer network. EX1010, [0004]. The network maintains a public ledger (e.g., bitcoin database) in which new transactions are

verified and recorded by members of the network via cryptography. *Id.* The operations of verifying and recording transactions of cryptocurrencies such as transactions in the bitcoin cryptocurrency are sometimes referred to as mining, because completion of each mining operation typically rewards the miner with newly created cryptocurrency (e.g., bitcoins). *Id.* Verified transactions and newly created bitcoins are recorded in the public ledger. *Id.* The public ledger serves as an official history of transactions. *Id.* The amount of cryptocurrency owned by any entity may be determined from the public ledger. *Id.*

VIII. OVERVIEW OF THE '372 PATENT

27. The '372 patent relates to “operating a blockchain mining device using natural gas produced at a hydrocarbon production, storage, or processing site/facility.” EX1001, Abstract. By way of background to its technology, the '372 Patent explains that “[a]t remote oil and gas facilities, excess natural gas is often wasted, for example vented to atmosphere or burned via flaring.” EX1001, 1:11-13. Figures 1 and 2 are schematics illustrating systems for “powering a blockchain [mining device (12)] at a remote oil well [14],” with a generator (28). EX1001, 5:53-62; 8:35-48.

28. Figure 1 (shown below) shows “a generator [28] retrofitted to a prime mover [24], which operates a drivehead to pump oil up from the reservoir.” EX1001, 5:53-56. That is, in this case, the blockchain mining device (12) is connected to a generator (28), which is retrofitted to a prime mover.

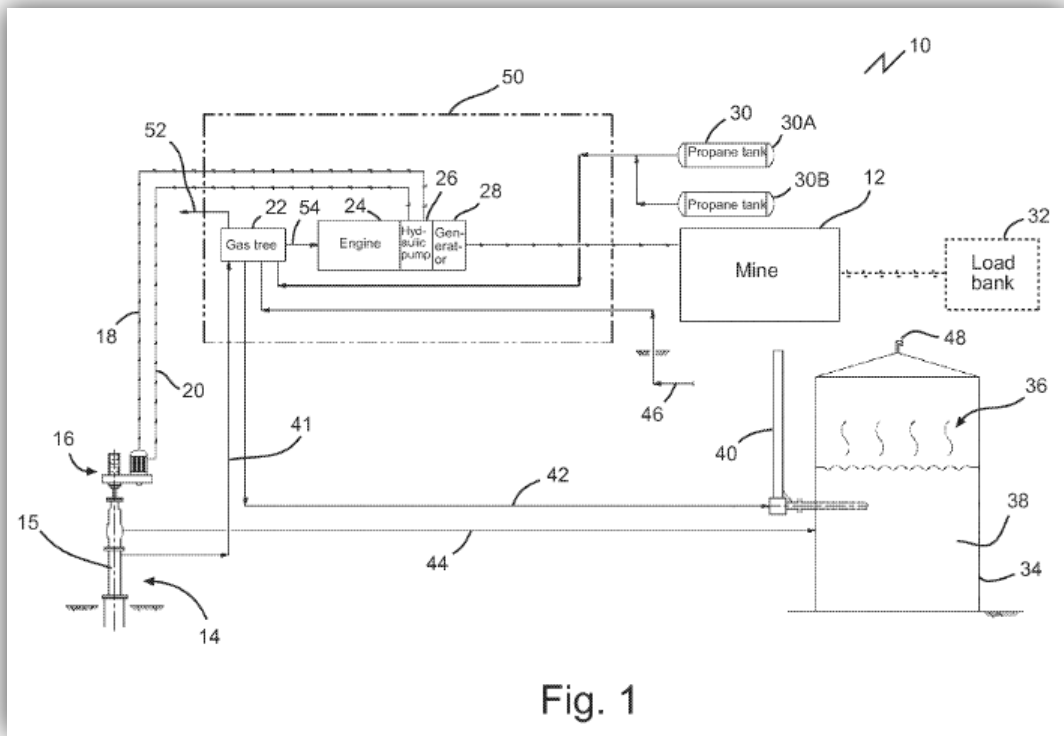
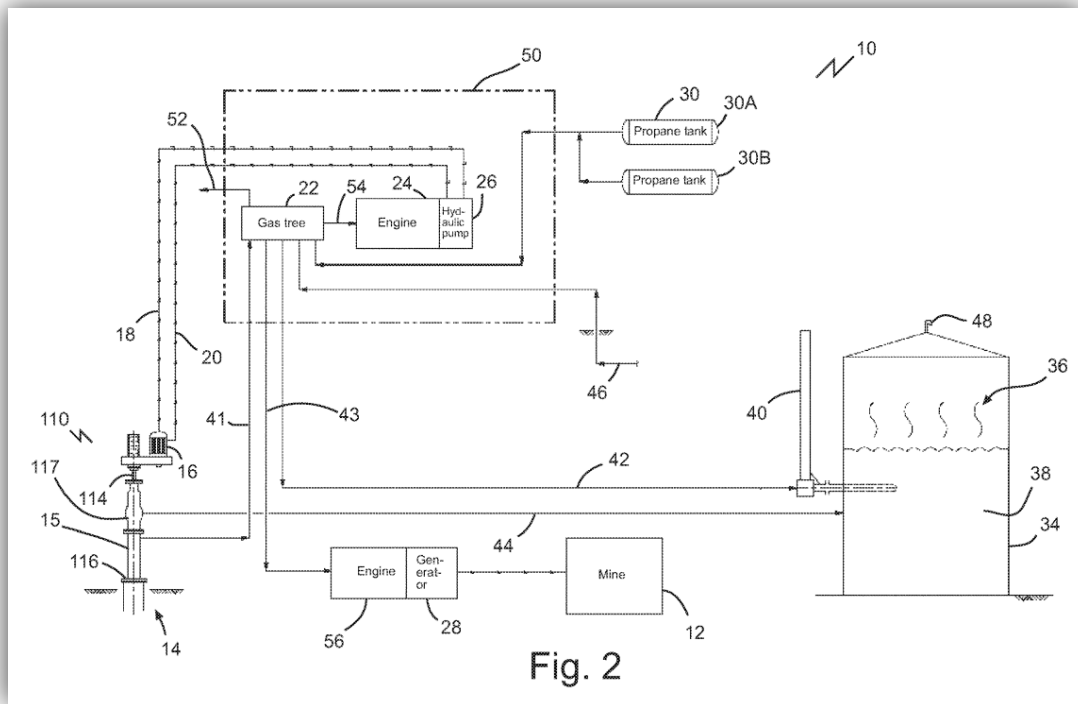

Fig. 1

'372 Patent, EX1001, Fig. 1

29. Figure 2 (shown below) is similar to Figure 1, but this embodiment includes two engines—one that (with a generator) powers the blockchain mining device (12), and one that operates the drive head. *See* EX1001, 5:57-62.



'372 Patent, EX1001, Fig. 2

30. Figure 3 (shown below) is a schematic illustrating another embodiment of a system for powering a blockchain mine, in which “a generator and engine are connected to be powered by combustible gas taken off of an oil storage unit to power the blockchain main.”

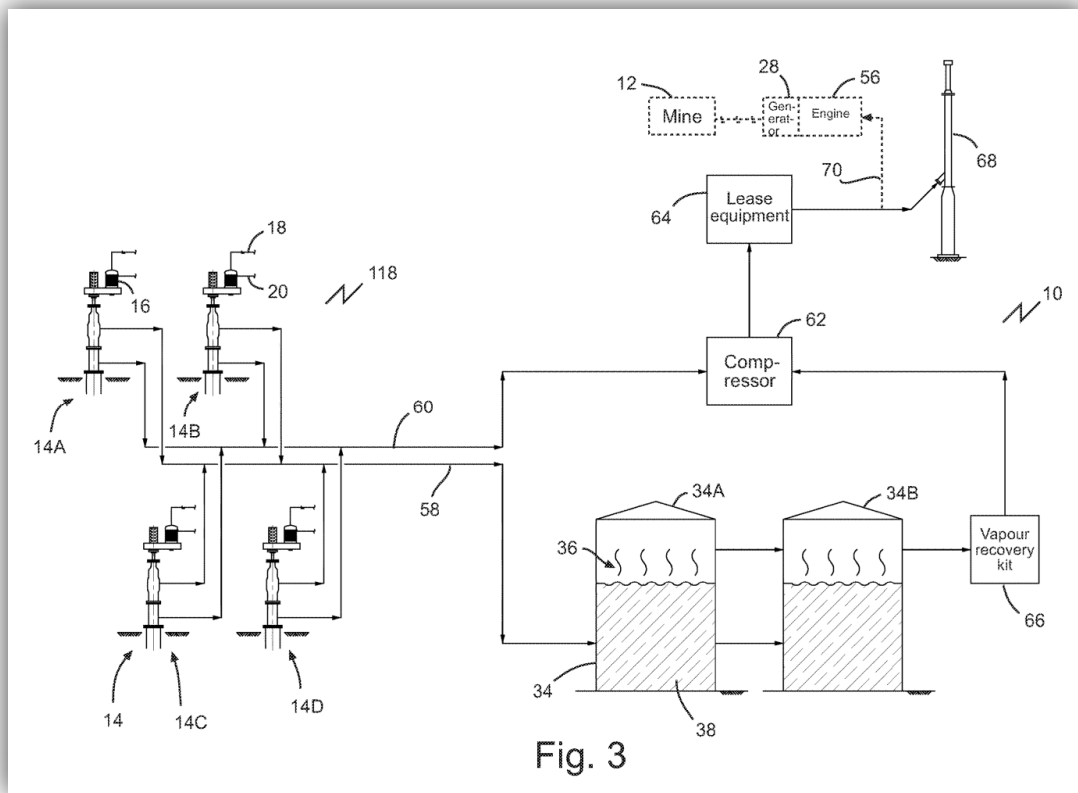

'372 Patent, EX1001, Fig. 3

31. Common among these three embodiments is that, in each case, a blockchain mining device is connected to a generator that runs on combustible gas – in particular, natural gas at an oil well or oil storage unit.

32. I understand that the '372 patent lists Stephen Barbour as the inventor, Upstream Data Inc. (“Upstream”) as the applicant and assignee, and has the title: “Blockchain Mine at Oil or Gas Facility.” For purposes of this declaration, I have been asked to assume that February 8, 2017, the filing date of US provisional application No. 62/456,380, is the earliest possible priority date for the '372 patent.

33. Generally, the '372 patent discusses systems and methods for using a source combustible gas to power bitcoin mining. I understand that in the related Complaint, Upstream

has relied specifically on claims 1 and 2 of the '372 patent.

IX. OVERVIEW OF THE PROSECUTION HISTORY

34. The application that led to the '372 patent was filed as U.S. Patent Application No. 16/484,728 on February 6, 2018. EX1002.

35. I understand that the '372 patent was filed with 41 claim, two of which were independent claims.

1. A system comprising:
a source of combustible gas produced from an oil production, storage, or processing facility;
a generator connected to the source of combustible gas; and
a blockchain mining device connected to the generator.

24. A method comprising using a source of combustible gas produced at a hydrocarbon production well, storage, or processing facility, to produce electricity to operate a blockchain mining device located at the hydrocarbon production well, storage, or processing facility, respectively.

EX1002, 686-691. I further understand that before examination, the claims were amended to “remove all multiple dependencies and reduce excess claim fees.” EX1002, 543-550. Claims 1 and 24 were not amended.

36. I understand that on August 9, 2021, before any office actions had been mailed, a third-party submission was made to cite a Reddit posting dated July 3, 2016. EX1002, 439-447. According to the third-party submitter, the Reddit posting “discloses a source of combustible gas, a generator that generate (sic) electricity from combustion of the gas, and a blockchain mining device.” EX1002, 440.

37. I understand that the Office initiated and conducted an interview with the Upstream’s representative on April 15, 2022, “to gain insight and a better understand (sic) the claimed invention as well as the oil/natural gas industry as it applies to block chain mining.”

EX1002, 348. The Office concluded that the third-party submission “reads adequately on the independent claims,” and suggested that “[m]oving forward, [] drafting independent claims that clearly unite the combustible gas production elements and the block chain mining elements.”

EX1002, 348. With respect to the dependent claims, the Office indicated that “[a]llowable subject matter may reside in dependent claims 12–18,” but that “further searching [would be] required.”

EX1002, 348. The Office’s initial search revealed little in the way of qualified prior art, but did reveal Belady-837 (US20140096837A1). EX1002, 348.

38. I understand that on April 19, 2022, before Upstream amended the claims, the Office mailed an Office Action. EX1002, 329-347. Claims 1 and 24, as well as dependent claims, were rejected for obviousness over Belady-837 and Gleifchauf (US20180109541A1). EX1002, 336. No anticipation rejections were made, despite the Office having indicated in the April 15 interview that the Reddit Post reads on the independent claims.

39. I understand that, in making the obviousness rejection, the Office took the position that Belady-837 discloses using a gas generator to power a data center (blockchain mining device), and Gleifchauf discloses using servers for blockchain mining and verification. EX1002, 336-337. According to the Office, it would have been obvious to combine Belady-837 and Gleifchauf because Belady-837 discloses “data centers are being located in areas where natural resources, from which electrical power can be derived, are abundant and can be obtained inexpensively. For example, natural gas is a byproduct of oil drilling operations and is often considered a waste byproduct since it cannot be economically captured and brought to the market.” EX1002, 336-337 (quoting EX1017, [0004]).

40. I understand that subsequent to receiving the obviousness rejection, Upstream amended the independent claims to recite:

1. A system comprising:
a source of combustible gas produced from [[an oil]]a facility selected from a group consisting of a hydrocarbon production, storage, or processing facility;
a generator connected to the source of combustible gas to receive a continuous flow of combustible gas to power the generator; and
[[a]] blockchain mining devices connected to the generator;
in which
the blockchain mining devices each have a mining processor and are connected to a network interface;
the network interface is connected to receive and transmit data through the internet to a network that stores or has access to a blockchain database;
the mining processors are connected to the network interface and adapted to mine transactions associated with the blockchain database and to communicate with the blockchain database;
the network is a peer-to-peer network;
the blockchain database is a distributed database stored on plural nodes in the peer-to-peer network; and
the blockchain database stores transactional information for a digital currency.

24. A method comprising:
Producing electricity using a generator and a source of combustible gas produced at a facility selected from the group consisting of a hydrocarbon production well, storage, or processing facility, to produce electricity to and operating[[e a]] blockchain mining devices located at the hydrocarbon production well, storage, or processing facility, respectively, using the electricity, in which:
the generator is connected to the source of combustible gas, in which the facility is connected to produce a continuous flow of combustible gas to the generator;
the blockchain mining devices [. . .].¹

41. I understand that, to overcome the obviousness rejection, Upstream argued that its system uses “flare gas” as opposed to “sales gas.” EX1002, 222-223. I understand that Upstream also argued that blockchain mining is different from traditional data-processing because it requires more energy. EX1002, 222-223. Upstream argued that its “discovery amounts to a new use for

¹ The remainder of the amendments to claim 24, with respect to the block chain mining devices, are identical to those made in claim 1. CRUSOE-1002 209-224.

previously known individual components (a common precursor for patentability), and may provide numerous benefits including the reduction of greenhouse gas emissions and capture of revenue where gas disposal is otherwise a capital loss (for example paragraphs 33, 34, 48, and 73), EX1002, 223.

42. I understand that on August 31, 2022, a notice of allowance was mailed. EX1002, 4-9. In the “Reasons for Allowance,” the Office indicated that:

With regard to any rejections under 35 USC § 101 based upon the Alice Corporation Pty. Ltd. v. CLS Bank guidelines, the Examiner finds that the claimed invention amounts to significantly more than a judicial exception or an abstract idea. Also, the claimed invention demonstrates a practical application. The specification clearly teaches and describes blockchain mining at hydrocarbon facility. Any rejections under 35 USC § 101 are hereby withdrawn. Additionally, the 2019 PEG defines the phrase “integration into a practical application” to require an additional element(s) or a combination of additional elements in the claim to apply, rely on, or use the judicial exception in a manner that imposes a meaningful limit on the judicial exception, such that it is more than a drafting effort designed to monopolize the exception. See MPEP 2106.04(d). I

With regard to the rejections under 35 USC § 103, the Examiner has carefully reviewed the Applicants responses filed on **07/04/2022**. Based upon the Applicants arguments and assertions, the Examiner is persuaded by and agrees with the Applicant. The assertions and arguments provided by the Applicant credibly declare and make clear that the independent claims and the limitations contained therein are allowable either in part or taken as a whole over the prior art of record. None of the art of record, taken individually or combination, disclose at least the method step or system components contained within the independent claims. Consequently, The prior art of record fails to fully disclose or reasonable teach the independent claims as a whole. See MPEP 1302.14. Moreover, even though the individual references applied in the prior art may teach each individual limitation sufficiently, there does not appear to be sufficient grounds for combining or modifying the prior art of record to adequately arrive at the claimed invention. See MPEP 2143.01.

43. I understand that the '372 patent issued shortly after a Rule 312 amendment (amending claims 15, 16, 18, 31, 37, 38, 40 to recite “hydrocarbon production well, storage, or

processing facility”). EX1002, 20-29.

44. I also understand that neither Dickerson, CryptoKube, Szmigielski, Kheterpal, Boot, Pioneer’s MAGS system, nor Polivka miner were considered by the Office. EX1002.

X. THE CHALLENGED CLAIMS

45. I understand that for purposes of this proceeding, Petitioner is challenging the validity of claims 1-4, 7-12, 15-30, 34-37, and 40 of the ’372 patent.

46. Claim 1 of the ’372 patent is representative of the challenged claims and is shown below:

1. A system comprising:

a source of combustible gas produced from a facility selected from a group consisting of a hydrocarbon production, storage, or processing facility;

a generator connected to the source of combustible gas to receive a continuous flow of combustible gas to power the generator; and

blockchain mining devices connected to the generator;

in which:

the blockchain mining devices each have a mining processor and are connected to a network interface;

the network interface is connected to receive and transmit data through the internet to a network that stores or has access to a blockchain database;

the mining processors are connected to the network interface and adapted to mine transactions associated with the blockchain database and to communicate with the blockchain database;

the network is a peer-to-peer network;

the blockchain database is a distributed database stored on plural nodes in the peer-to-peer network; and

the blockchain database stores transactional information for a digital currency.

XI. CLAIM CONSTRUCTION

47. I understand that Petitioner reserves the right to assert in litigation that certain claim constructions are proper and that certain terms are indefinite, and I do not concede, by providing my opinions herein, that the challenged claims are of definite scope or properly described.

48. For the purposes of this declaration, no formal claim constructions are presently necessary, besides the specific constructions described below.

49. The term “blockchain mining device” should be construed as “any computing device that is capable of performing blockchain mining without regard to processor speed or power.” The ‘372 patent explains that “[a] blockchain is a form of database, which may be saved as a distributed ledger in a network of nodes,” where each node “maintains a continuously-growing list of records called blocks.” [EX1001, 11:46-47]. The nodes 122 are said to be “electronic devices 126, for example desktop computers, laptop computers, tablet computers, cellular telephones, servers, or other suitable devices.” [EX1001, 14:30-33].

50. The ‘372 patent further explains that “mining” refers to the “computational review process performed on each block of data in a blockchain” required to “maintain[]a blockchain database.” [EX1001, 13:5-7]. Importantly, in order for a node 122 (computing device) to operate as a miner with respect to a blockchain, it must simply include “mining circuitry 130 ... to perform data mining operations.” [EX1001, 14:44-48]. Unsurprisingly, the ‘372 patent admits that such “mining circuitry” may simply be “an integrated circuit chip” (i.e., a processor) with “various mining circuitry examples includ[ing] CPU (central processing unit), GPU (graphics processing unit), FPGA (Field-Programmable Gate Array), and ASIC (application specific integrated circuit).” [EX1001, 14:61-63; 17:12-15]. In other words, no special purpose hardware is required to mine blockchain transactions. Indeed, several brands of cryptocurrencies (i.e., blockchains) still exist to this day that can be profitably mined using a standard computer. For example, the website Brave New Coin reports that, although Bitcoin-brand cryptocurrency can no longer be profitably mined with a standard PC, there still exists other brands of “[c]rypto you can mine from a home computer in 2023.” EX1022.

51. The term “mining processor” should be construed as “any processor that is capable of performing blockchain mining without regard to processor speed or power.” See discussion regarding “blockchain mining device” above.

52. The term “a continuous flow of combustible gas” should be construed as “a flow of combustible gas that is continuous for at least a time period (e.g., an hour, a day, a week, a month, or longer).” For this construction, I relied on Dr. Michael Nikolaou.

53. The term “sales gas line” should be construed as “a pipeline for long-distance transportation of sales gas meeting sales-gas specifications from a hydrocarbon production, storage, or processing facility to a customer connected to the pipeline.” For this construction, I relied on Dr. Michael Nikolaou.

54. I reserve the right to supplement my opinions if Patent Owner offers a construction of any term in the '372 patent.

XII. SUMMARY OF THE PRIOR ART

A. Dickerson

55. I relied on Dr. Michael Nikolaou’s review of Dickerson in forming my opinions.

56. I understand that PCT Publication No. 2015/123,257 (“Dickerson”) has an international publication date of August 20, 2015. [EX1005, Cover].

57. I understand that Dickerson “relates generally to a mobile apparatus, system, and method for processing and using raw natural gas that is normally flared at the site of oil and gas field operation facilities.” [EX1005, [0002]].

58. I understand that Dickerson describes a mobile power generation system that can generate electricity using flare gas (raw natural gas that is to be flared) at an oil and gas production facility. [EX1005, Abstract, [0002]]. Dickerson explains that “[g]as flared as a byproduct of oil drilling in the Bakken Field releases millions of tons of carbon dioxide into the atmosphere every

year, causing considerable environmental concerns” and “a number of oil and gas field facilities where gas is being flared rely on diesel-powered electrical generating units for electricity needed to run the facilities.” [EX1005, [0003], [0004]].

59. I understand that Dickerson discloses that it seeks to “reduce costs associated with diesel-powered electrical generating units, to eliminate undesirable emissions generated by flaring natural gas, and to reduce emissions from the generation of electricity used to operate oil and gas field facilities, since electricity produced by gas engines results in fewer harmful emissions than electricity produced by diesel-fuel engines.” [EX1005, [0010]].

60. I understand that Dickerson’s system includes (1) one membrane separation unit for separating useful fuel gas from raw natural gas produced at an oil or gas production facility, (2) a gas engine that uses the fuel gas to generate electricity that is returned to the facility, and (3) a control panel for operating the apparatus. [EX1005, [0005]]. FIG. 1 of Dickerson shows one setup of its combined gas conditioning and power generation system. [EX1005, [0008]]. As shown in FIG. 1, gas genset 102 includes a gas engine 110 and a generator 112 that is driven by the engine 110. [EX1005, [0026]].

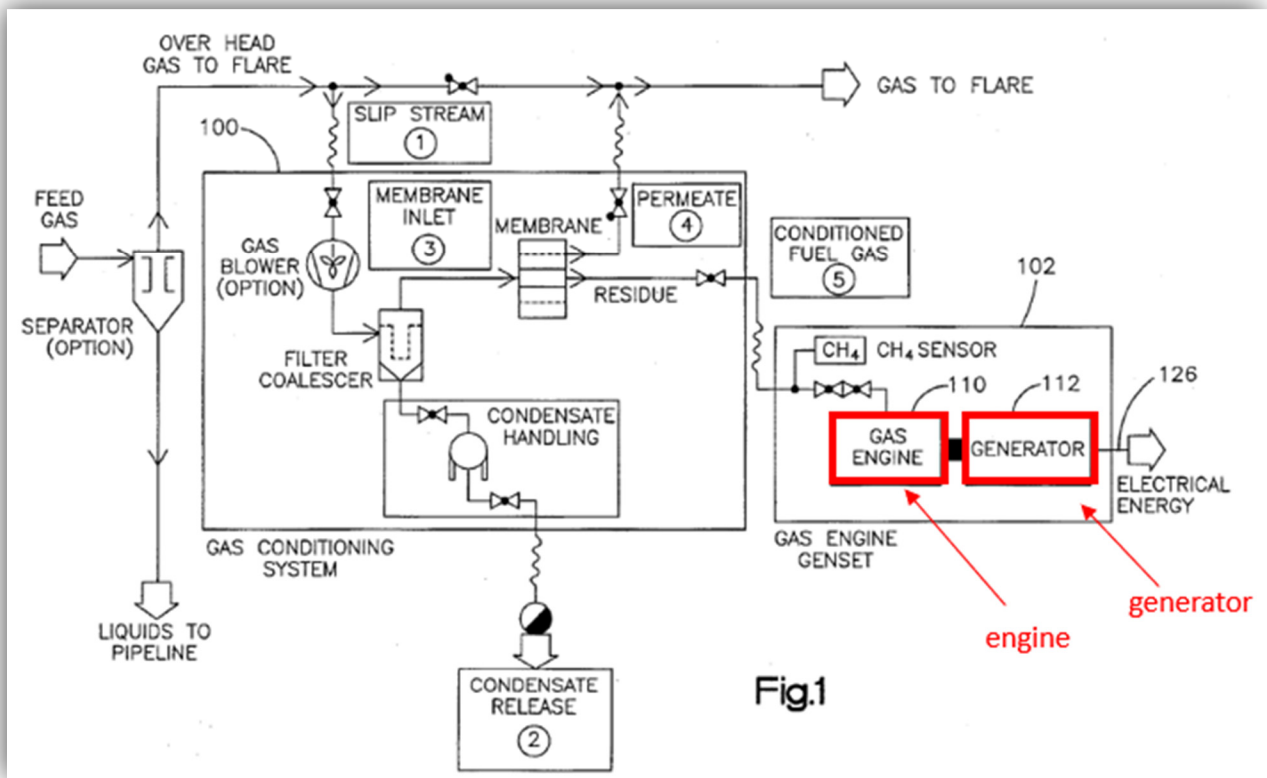

Fig.1

Dickerson, EX1005, FIG. 1 (annotated)

61. I understand that Dickerson further discloses that a chiller unit can be included to remove natural gas liquids (NGLs) from the raw natural gas stream, and to further reduce the flaring of raw natural gas. [EX1005, [0022]].

62. I understand that Dickerson discloses that its mobile power generation system can be delivered in a 40-foot-long ISO container. [EX1005, [0014]]. Dickerson explains that the container and its contents together define a self-contained, mobile flare gas processing unit that provides a user with electrical power output but requires only feed gas input from the user. [EX1005, [0026]]. Dickerson envisions using the generated electricity for both local consumption and for export. [EX1005, [0039]].

B. CryptoKube

63. The CryptoKube system is a commercialized industrial Bitcoin mining system that can be easily shipped to any location that has cheap power and can mine bitcoin. [EX1006, 1-4]. The CryptoKube is built inside an ISO shipping container and is filled with spondooliestech SP31 OR SP35 servers. [EX1006, 4]. The CryptoKube uses fans (fresh air cooling) to move large volumes of air through the data center to cool the servers and remove the hot air exhaust. [EX1006, 1, 4].

64. As shown in the CryptoKube video, the CryptoKube is built inside an ISO shipping container with walls, a top, and a base, with an access door formed in the walls. CryptoKube can run inside a large warehouse, outside in a parking lot, or in a server pod farm where the power is cheapest. [EX1006, 1-4]; [EX1007, 0:01:08]. The CryptoKube video and CryptoKube brochure were both published in 2014.



CryptoKube Video, EX1007, 0:01:08.

C. **Szmiegielski**

65. Szmigielski is a book titled “Bitcoin Essentials,” first published in February 2016, where the author reviewed the mining of bitcoin—how new bitcoins are created and how transactions are accepted into the Bitcoin blockchain. [EX1009, 12]. Chapter 1 reviews bitcoin wallets and mining software. Chapters 2-5 cover CPU, GPU, FPGA, and ASIC mining. Chapter 6 talks about solo versus pool mining. Chapter 7 talks about large scale mining, and Chapter 8 discusses the future of bitcoin mining. [EX1009, 13].

66. The Bitcoin database that stores all the transaction data is called a “block chain.” [EX1009, 17]. Mining software coordinates and manages the work of different mining devices. [EX1009, 29]. Electricity is a big part of the cost of mining, and it is very important to set up a mining operation where electricity is cheap or perhaps even free. [EX1009, 86].

67. Industrial miners face almost the same issues as data centers: access to relatively cheap power, good network access, access to latest hardware, and stable political climate. [EX1009, 88]. One of the biggest costs for Bitcoin miners is the cost of electricity. [EX1009, 90]. Electricity is needed in both running the hardware and the associated cooling systems, be it fans or air conditioning. *Id.* Miners, therefore, seek out locations where electricity is fairly priced. *Id.* In North America, the biggest industrial Bitcoin mine is located in eastern Washington state due to the abundance of inexpensive hydroelectric power. *Id.*

D. Kheterpal

68. US Patent Publication No. 2016/0125,040 (“Kheterpal”) was published on May 5, 2016 and discloses the design and operation of a bitcoin miner chip. [EX1010, Abstract]. FIG. 1 is an illustrative diagram of a peer-to-peer network 100 that may operate according to the Bitcoin protocol. [EX1010, [0030]]. Network 100 includes plural nodes 10 that are coupled to other nodes via paths 12 (e.g., Internet) and nodes 10 may be electronic devices such as desktop computers,

laptop computers, cellular telephones, servers, or other electronic devices that implement the Bitcoin protocol. *Id.*

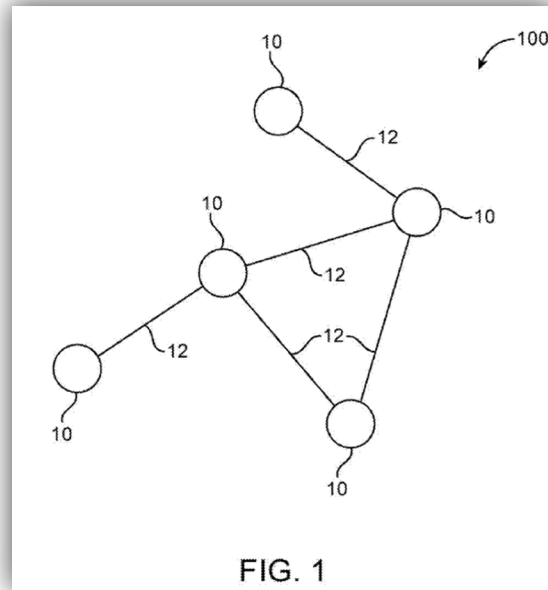

Kheterpal EX1010, FIG. 1

69. Nodes 10 may communicate to maintain a global ledger (e.g., bitcoin database) of all official transactions, and each node 10 may store a copy of the global ledger (e.g., a complete copy or only a partial copy). [EX1010, [0031]]. Transactions added to the global ledger by each node 10 may be verified by other nodes 10 to help ensure validity of the ledger. *Id.*

70. The Bitcoin protocol defines a system in which the creation and distribution of the bitcoin cryptocurrency is governed by consensus among a peer-to-peer network. [EX1010, [0004]]. The network maintains a public ledger in which new transactions are verified and recorded by members of the network via cryptography. *Id.* The operations of verifying and recording transactions of cryptocurrencies such as transactions in the bitcoin cryptocurrency are sometimes referred to as mining, because completion of each mining operation typically rewards the miner with newly created cryptocurrency (e.g., bitcoins). *Id.* Verified transactions and newly created

bitcoins are recorded in the public ledger. *Id.* The public ledger serves as an official history of transactions. *Id.* The amount of cryptocurrency owned by any entity may be determined from the public ledger. *Id.*

E. Belady-989

71. I relied on Dr. Michael Nikolaou's review of Belady-989 in forming my opinions.

72. I understand that PCT Patent Publication No. 2015/072989 ("Belady-989") has an international publication date of May 21, 2015. [EX1011, Cover].

73. I understand that Belady-989 describes a gas supply shock absorber (containing a gas storage) that is used to improve a data center system powered by a natural gas generator. [EX1011, Abstract]. If the shock absorber has sufficient gas, a co-located data center utilizes such gas for increased electrical power generation during increased processing activity, which can be requested or generated. [EX1011, Abstract]. Conversely, if the shock absorber has insufficient gas, and a negative pressure spike occurs, the data center throttles down or offloads processing. [EX1011, Abstract]. FIG. 1 illustrates Belady-989's system.

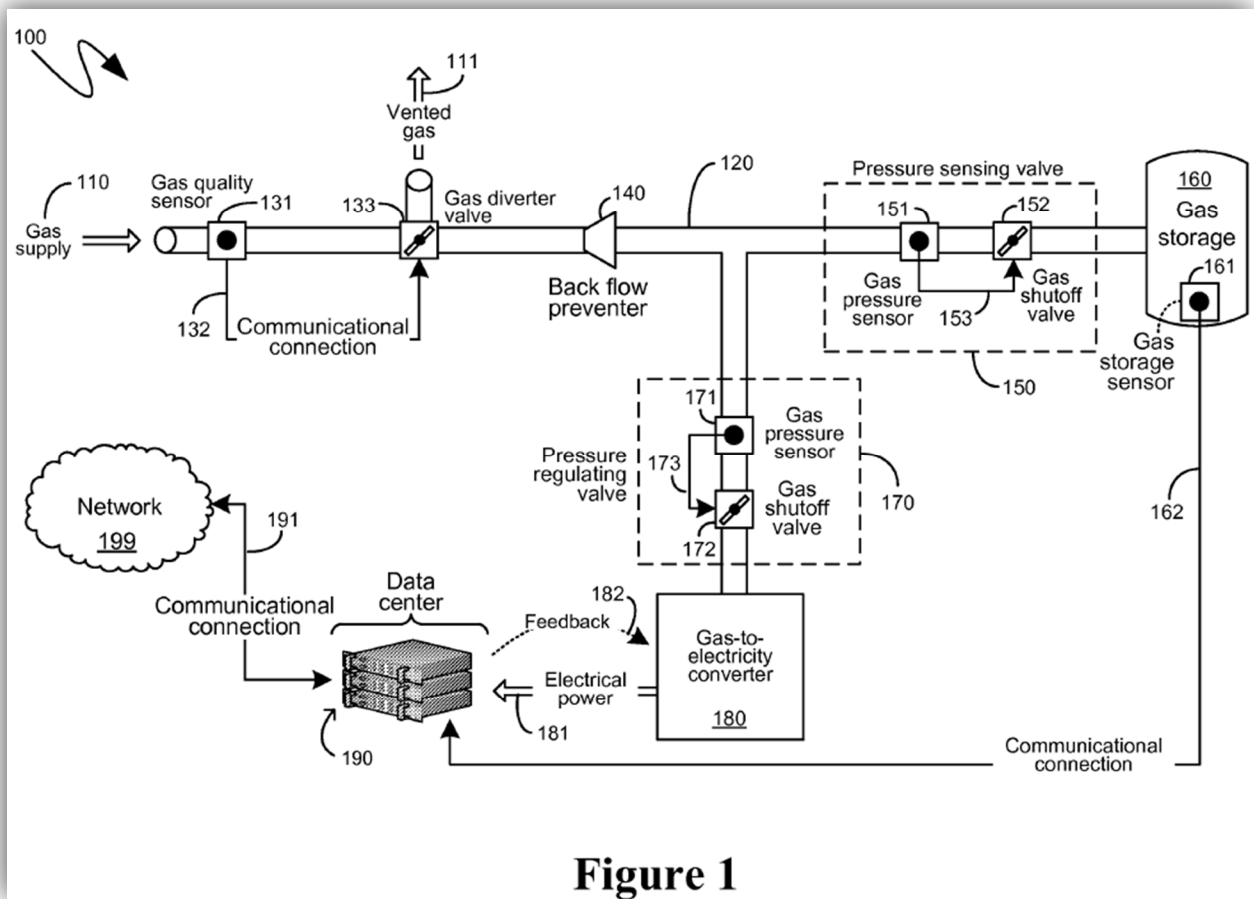

Figure 1

Belady-989, EX1011, FIG. 1

74. I understand that, as shown in FIG. 1, the data center 190 is connected to network 199, and is powered by a gas-to-electricity converter 180, which can be a gas generator. [EX1011, [0019]]. Belady-989’s data center system “can be located in an area where gas supply 110 can be plentiful or otherwise available at a minimal cost, but such a gas supply 110 can also experience pressure spikes.” [EX1011, [0019]]. The gas supplied by the gas supply 110 can include natural gas, biogas, methane, propane or other hydrocarbons, hydrogen, or any other fuel that can be accepted by gas-to-electricity converter 180, such as a generator. [EX1011, [0019]].

F. Boot

75. I relied on Dr. Michael Nikolaou’s review of Boot in forming my opinions.

76. I understand that U.S. Patent No. 9,394,770 (“Boot”) was issued on July 19, 2016. [EX1012, Cover].

77. I understand that Boot describes a mobile power generation system that can generate electricity using flare gas (raw natural gas that is to be flared) at an oil and gas production facility that is isolated from a power grid. [EX1012, Abstract, 1:5-10, 4:6-7]. Boot explains that “[t]he driver is preferably an engine that is provided with combustible gases from the petroleum products of the well” and “[i]n the past, such gas have often been vented or flared at the well 118.” [EX1012, 1:55-57, 4:6-7].

78. I understand that, as shown in FIG. 1, Boot’s system includes a genset 102, a fuel source 104, an integrated control system 106, a load bank 110, and one or more loads 108. [EX1012, 2:23-28]. The genset 102 includes a driver (engine) 112 coupled to a generator 114. [EX1012: 29-35]. The loads 108 are general references for devices or systems that consume electrical power (e.g., electric motors, computers). [EX1012, 35-41].

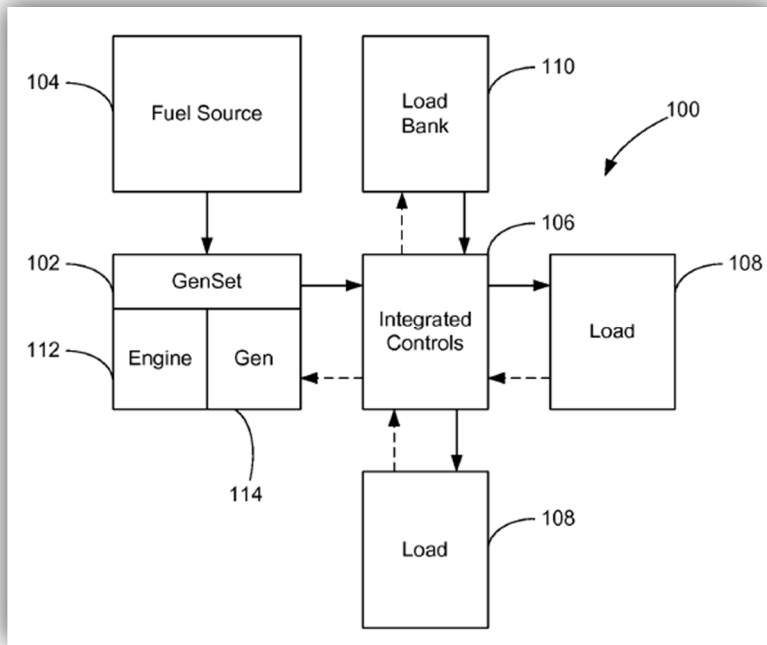

Boot, EX1012, FIG. 1

79. I understand that Boot explains that the load bank 110 can be activated to take-up any excess power to maintain a minimum load to keep the engine 112 within its preferred operating parameters. [EX1012, 3:8-14]. Boot's system can be positioned on a common platform or skid 130, which is configured to be rolled on and off a conventional lowboy trailer. [EX1012, 4:27-37].

80. I understand that, in FIG. 2, Boot further discloses that the flare gas can be derived from more than one well heads (well 118). [EX1012, FIG. 2, 3:42-46]. Boot further discloses that the electric submersible pumping system 116 pushes pumped fluids out of the well 118 to surface facilities 120 (e.g., phase separators, storage batteries and gathering lines), which output the flare gas to the genset 102 to generate electricity. [EX1012, 3:37-42].

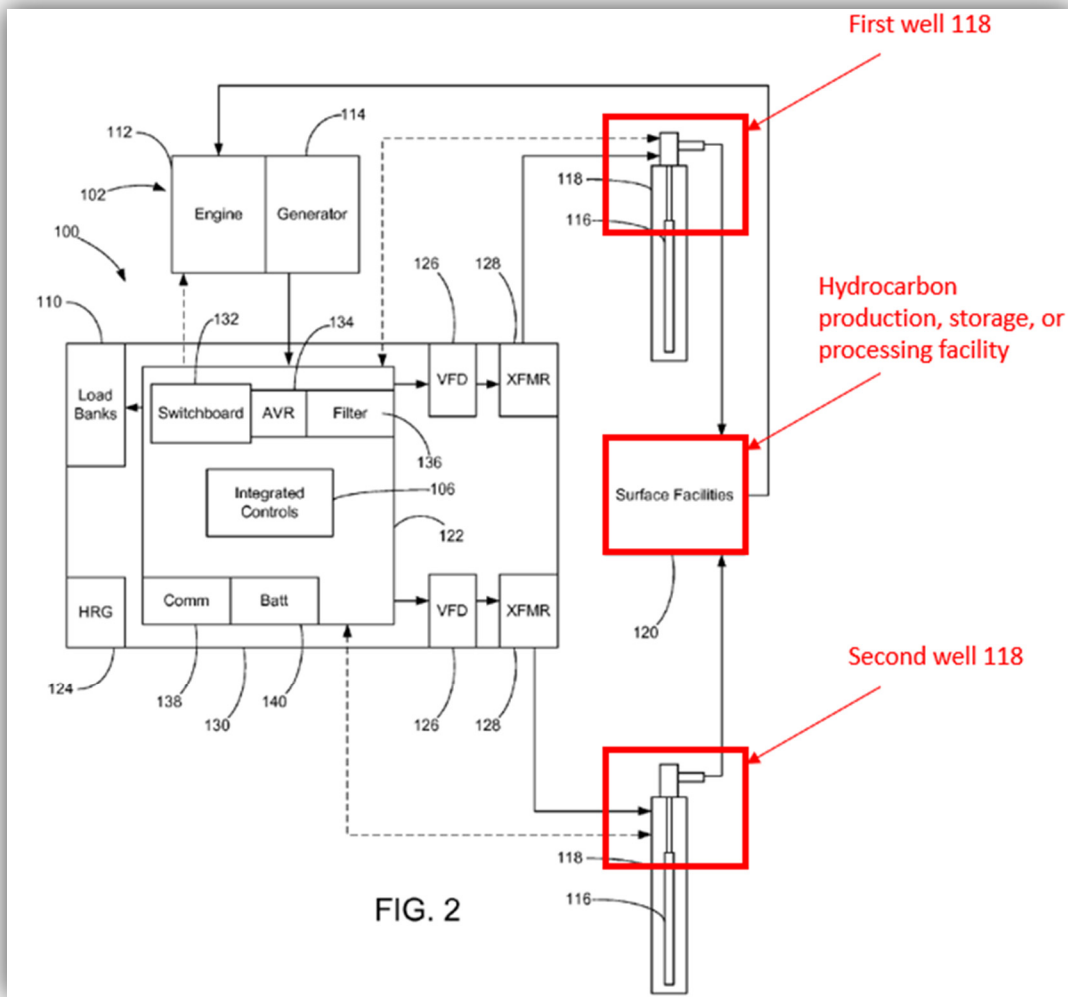

Boot, EX1012, FIG. 2 (annotated)

G. Pioneer Energy’s MAGS System

81. I relied on Dr. Michael Nikolaou’s review of the MAGS System in forming my opinions.

82. I understand that Pioneer Energy’s Mobile Alkane Gas Separator (MAGS) system (“MAGS” for short) separates flare gases that naturally occur at drilling sites into three streams: one can be captured in tanks and shipped off for sale, another powers generators that run the drilling operation, and a third powers MAGS itself. [EX1013, 2]. Pioneer sold its first MAGS unit

in late 2014 to a company operating in North Dakota, where flare gases are most often simply burned onsite, the gases wasted. [EX1013, 2].



Pioneer Energy's MAGS System, EX1013, 2

83. I understand that some of the engineering details of the MAGS system are described in US Patent Publication No. 2015/0368566 (“Young”). For example, as described in Young, the ethane-enriched B-gas is combusted in an internal engine 719a and the mechanical shaft power is transmitted to a 480 VAC internal generator 719b operating at 60 Hz. [EX1014, [0198]]. Young also discloses that the MAGS system is containerized to fit on a trailer to confer better mobility. [EX1014, [0162], FIG. 4].

H. Polivka miner

84. The Polivka miner is described in a Bitcointalk forum post thread that was kept in a May 11, 2015 WayBackMachine snapshot (“the Bitcointalk forum post”). [EX1015]. The

Polivka miner is also depicted in a Youtube video dated February 9, 2015 (“Polivka video”). [EX1019].

85. As shown in the Bitcointalk forum post, the Polivka miner (“Polivka” for short) is adapted from a standard intermodal shipping container, and can be easily transported to remote well sites. [EX1015, 1-10]; [EX1019, 0:00:08]. For example, the Bitcointalk forum post explains that “the container can be loaded and unloaded without crane using the pictured pillars and an air-suspended truck only. (Almost all of the trucks in Europe have air suspension).” [EX1015, 10].



Bitcointalk forum post, EX1015, 1

86. As shown in the below figure, the Polivka miner contains a cooling fan, multiple bitcoin miners on a rack, and a power distribution box on the left side.



Bitcointalk forum post, EX1015, 31

87. As explained in the Bitcointalk forum post, the Polivka miner can carry various miners including Spondoolies-Tech SP31 and Bitmain Antminer S19. [EX1015, 17]. The Bitcointalk forum post also explains that cheap electricity is desired and required. [EX1015, 15, 21]. The Bitcointalk forum post also envisions powering the Polivka miner by gas using a combustion engine. [EX1015, 18].

XIII. ANALYSIS OF DICKERSON AND CRYPTOKUBE (GROUND 1)

88. For the reasons articulated in detail below, and based on my review of the '372 patent, the file history, the prior art cited here, Dr. Michael Nikolaou's declaration, and my years of experience in the bitcoin mining industry, a POSITA would have readily understood that claims 1-4, 8, 16-30, and 34 are obvious over the combination of Dickerson and CryptoKube, in view of Szmigielski and Kheterpal.

A. It Would Have Been Obvious to a POSITA to Combine Dickerson and

CryptoKube, in view of Szmigielski and Kheterpal.

89. A POSITA would have found it obvious to combine Dickerson's mobile power generation system with CryptoKube's mobile bitcoin miner, wherein the bitcoin mining devices (spondooliestech SP31 OR SP35 servers) are connected to and powered by Dickerson's generator, in view of Szmigielski and Kheterpal.

90. Dickerson discloses a mobile power generation system that can generate electricity using flare gas (raw natural gas that is to be flared) at an oil and gas production facility. [EX1005, Abstract, [0002]]. Dickerson discloses that the power generated may be more than the power required on an oil field pumping site, and that its system can provide power for both local consumption and also for export to the grid at the same time if utility power lines are accessible. [EX1005, [0039]]. Dickerson also discloses that oil and gas production facilities are typically located in remote areas where no utility power is available. [EX1005, [0024]].

91. Thus, a POSITA would have understood that Dickerson's system can generate free or cheap excess electricity that cannot be exported to the grid (because no utility power lines are accessible).

92. Szmigielski discloses that one of the biggest costs for Bitcoin miners is the cost of electricity and access to cheap power is desired. [EX1009, 90].

93. A POSITA would have been motivated to couple a bitcoin miner to Dickerson's system to utilize the free excess electricity.

94. CryptoKube is a mobile bitcoin miner that can be easily transported to a remote oil and gas production facility. [EX1006, 1-4].

95. Thus, a POSITA would have found it obvious to couple the CryptoKube system with Dickerson's system to utilize the free excess electricity.

96. Both the Dickerson system and the CryptoKube system are containerized and built inside an ISO shipping container to confer better mobility. [EX1005, [0014]]; [EX1006, 1-4]. Thus, it is easy to combine the two by simply combining two ISO shipping containers into one.

97. In the Dickerson-CryptoKube combination, the combined device would have (1) Dickerson's mobile power generation system; and (2) CryptoKube's mobile bitcoin miner, wherein the bitcoin mining devices (spondooliestech SP31 OR SP35 servers) are connected to and powered by Dickerson's generator.

B. The Combination of Dickerson and CryptoKube Renders Claims 1-4, 8, 16-30, and 34 Obvious.

98. As I explain below, the combination of Dickerson and CryptoKube renders obvious all limitations of claims 1-4, 8, 16-30, and 34. As stated above, I relied on Dr. Nikolaou's opinions and explanations related to Dickerson for the purposes of this Declaration.

a. Independent Claim 1

i. *Limitation [1pre]*

"A system comprising:"

99. To the extent the preamble is limiting, the Dickerson-CryptoKube combination renders [1pre] obvious. For example, Dickerson describes a mobile power generation system that can generate electricity using flare gas (raw natural gas that is to be flared) at an oil and gas production facility. [EX1005, Abstract, [0002]]. CryptoKube also discloses a bitcoin miner system. [EX1006, 1-4].

ii. *Limitation [1a]*

"a source of combustible gas produced from a facility selected from a group consisting of a hydrocarbon production, storage, or processing facility;"

100. See Dr. Nikolaou's declaration on Limitation [1a].

iii. *Limitation [1b]*

“a generator connected to the source of combustible gas to receive a continuous flow of combustible gas to power the generator; and”

101. See Dr. Nikolaou’s declaration on Limitation [1b].

iv. Limitation [1c]

“blockchain mining devices connected to the generator; in which:”

102. As discussed above, in the Dickerson-CryptoKube combination, the combined device would have (1) Dickerson’s mobile power generation system; and (2) CryptoKube’s mobile bitcoin miner, wherein the bitcoin mining devices (spondooliestech SP31 OR SP35 servers) are connected to and powered by Dickerson’s generator.

103. For these reasons, and for the reasons provided by Dr. Nikolaou, I believe a POSITA would have understood that the Dickerson-CryptoKube combination discloses this limitation.

v. Limitation [1c_i]

“the blockchain mining devices each have a mining processor and are connected to a network interface;”

104. The CryptoKube is built inside an ISO shipping container and is filled with spondooliestech SP31 OR SP35 servers, that is, blockchain mining devices, each necessarily having a mining processor. [EX1006, 1-4]. CryptoKube also provides “a best of class internet firewall.” [EX1006, 4]. CryptoKube contains routers. [EX1023, 00:00:11]. A POSITA would have understood that to mine bitcoin, the bitcoin miners need to be connected to a network interface (e.g., a modem or a router). For example, Kheterpal explains that the Bitcoin protocol defines a system in which the creation and distribution of the bitcoin cryptocurrency is governed by consensus among a peer-to-peer network. [EX1010, [0004]]. The network maintains a public ledger (e.g., bitcoin database) in which new transactions are verified and recorded by members of the network via cryptography. *Id.* The operations of verifying and recording transactions of

cryptocurrencies such as transactions in the bitcoin cryptocurrency are sometimes referred to as mining, because completion of each mining operation typically rewards the miner with newly created cryptocurrency (e.g., bitcoins). *Id.* Verified transactions and newly created bitcoins are recorded in the public ledger. *Id.* The public ledger serves as an official history of transactions. *Id.* The amount of cryptocurrency owned by any entity may be determined from the public ledger. *Id.*

105. For these reasons, I believe a POSITA would have understood that CryptoKube meets this limitation.



[EX1023, 00:00:11].

vi. Limitation [1c_ii]

“the network interface is connected to receive and transmit data through the internet to a network that stores or has access to a blockchain database;”

106. The CryptoKube is built inside an ISO shipping container and is filled with spondooliestech SP31 OR SP35 servers. [EX1006, 1-4]. A POSITA would have understood that

to mine bitcoin, the bitcoin miner needs to receive and transmit data through the internet to a network that stores or has access to a blockchain database. For example, Kheterpal explains that the Bitcoin protocol defines a system in which the creation and distribution of the bitcoin cryptocurrency is governed by consensus among a peer-to-peer network. [EX1010, [0004]]. The network maintains a public ledger in which new transactions are verified and recorded by members of the network via cryptography. *Id.* The operations of verifying and recording transactions of cryptocurrencies such as transactions in the bitcoin cryptocurrency are sometimes referred to as mining, because completion of each mining operation typically rewards the miner with newly created cryptocurrency (e.g., bitcoins). *Id.* Verified transactions and newly created bitcoins are recorded in the public ledger. *Id.* The public ledger serves as an official history of transactions. *Id.* The amount of cryptocurrency owned by any entity may be determined from the public ledger. *Id.*

107. For these reasons, I believe a POSITA would have understood that CryptoKube meets this limitation.

vii. *Limitation [1c_iii]*

“the mining processors are connected to the network interface and adapted to mine transactions associated with the blockchain database and to communicate with the blockchain database;”

108. The CryptoKube is built inside an ISO shipping container and is filled with spondooliestech SP31 OR SP35 servers. [EX1006, 1-4]. A POSITA would have understood that to mine bitcoin, the mining processors need to be connected to a network interface and adapted to mine transactions associated with the blockchain database and to communicate with the blockchain database. [EX1010, [0004]]. For example, Kheterpal explains that the Bitcoin protocol defines a system in which the creation and distribution of the bitcoin cryptocurrency is governed by consensus among a peer-to-peer network. [EX1010, [0004]]. The network maintains a public ledger in which new transactions are verified and recorded by members of the network via

cryptography. *Id.* The operations of verifying and recording transactions of cryptocurrencies such as transactions in the bitcoin cryptocurrency are sometimes referred to as mining, because completion of each mining operation typically rewards the miner with newly created cryptocurrency (e.g., bitcoins). *Id.* Verified transactions and newly created bitcoins are recorded in the public ledger. *Id.* The public ledger serves as an official history of transactions. *Id.* The amount of cryptocurrency owned by any entity may be determined from the public ledger. *Id.*

109. For these reasons, I believe a POSITA would have understood that CryptoKube meets this limitation.

viii. Limitation [1c_iv]

“the network is a peer-to-peer network;”

110. A POSITA would have understood that bitcoin mining is conducted on a peer-to-peer network, because Bitcoin protocol defines a system in which the creation and distribution of the bitcoin cryptocurrency is governed by consensus among a peer-to-peer network. [EX1010, [0004]].

111. For these reasons, I believe a POSITA would have found it obvious that the network is a peer-to-peer network.

ix. Limitation [1c_v]

“the blockchain database is a distributed database stored on plural nodes in the peer-to-peer network; and”

112. A POSITA would have understood that in a bitcoin network, the blockchain database is a distributed database stored on plural nodes in the peer-to-peer network. [EX1010, [0004]]. For example, Kheterpal explains that the Bitcoin protocol defines a system in which the creation and distribution of the bitcoin cryptocurrency is governed by consensus among a peer-to-peer network. [EX1010, [0004]]. The network maintains a public ledger in which new transactions

are verified and recorded by members of the network via cryptography. *Id.* The operations of verifying and recording transactions of cryptocurrencies such as transactions in the bitcoin cryptocurrency are sometimes referred to as mining, because completion of each mining operation typically rewards the miner with newly created cryptocurrency (e.g., bitcoins). *Id.* Verified transactions and newly created bitcoins are recorded in the public ledger. *Id.* The public ledger serves as an official history of transactions. *Id.* The amount of cryptocurrency owned by any entity may be determined from the public ledger. *Id.*

113. For these reasons, I believe a POSITA would have found this limitation obvious.

x. *Limitation [1c_vi]*

“the blockchain database stores transactional information for a digital currency.”

114. A POSITA would have understood that in a bitcoin network, the blockchain database stores transactional information for a digital currency. [EX1010, [0004]]. For example, Kheterpal explains that the Bitcoin protocol defines a system in which the creation and distribution of the bitcoin cryptocurrency is governed by consensus among a peer-to-peer network. [EX1010, [0004]]. The network maintains a public ledger in which new transactions are verified and recorded by members of the network via cryptography. *Id.* The operations of verifying and recording transactions of cryptocurrencies such as transactions in the bitcoin cryptocurrency are sometimes referred to as mining, because completion of each mining operation typically rewards the miner with newly created cryptocurrency (e.g., bitcoins). *Id.* Verified transactions and newly created bitcoins are recorded in the public ledger. *Id.* The public ledger serves as an official history of transactions. *Id.* The amount of cryptocurrency owned by any entity may be determined from the public ledger. *Id.*

115. For these reasons, I believe a POSITA would have found this limitation obvious.

b. Dependent Claim 2

“The system of claim 1 isolated from a sales gas line and an external electrical power grid.”

116. See Dr. Nikolaou’s declaration on Limitation [2].

c. Dependent Claim 3

“The system of claim 1 in which: the source of combustible gas and the facility comprise a remote well selected from a group consisting of a remote oil or gas well; and the remote well is connected to produce the continuous flow of combustible gas to power the generator.”

117. See Dr. Nikolaou’s declaration on Limitation [3].

d. Dependent Claim 4

“The system of claim 3 further comprising a combustion engine connected to the source of combustible gas and connected to drive the generator.”

118. See Dr. Nikolaou’s declaration on Limitation [4].

e. Dependent Claim 8

“The system of claim 1 in which the generator and blockchain mining devices are located adjacent to the facility.”

119. A POSITA would understand that the ’372 patent discloses that the generator and blockchain mining device may be located adjacent to the remote oil well, for example within one hundred meters. [The ’372 patent, 9:17-19].

120. As discussed above, in the Dickerson-CryptoKube combination, the combined device would have (1) Dickerson’s mobile power generation system; and (2) CryptoKube’s mobile bitcoin miner, wherein the bitcoin mining devices (spondooliestech SP31 OR SP35 servers) are connected to and powered by Dickerson’s generator. Both the Dickerson system and the CryptoKube system are containerized and built inside an ISO shipping container to confer better mobility. [EX1005, [0014]]; [EX1006, 1-4].

121. Per Dr. Nikolaou’s Declaration, Dickerson discloses that the gas engine genset is compact, containerized/skid mounted, and mobile which makes the system particularly suitable

for remote sites. [EX1005, [0027]]. Dickerson discloses that its system allows “utilizing field gas directly and avoids to move the gas from a remote float/station to a processing field line before utilizing.” [EX1005, [0036]].

122. The CryptoKube video shows that the CryptoKube is built inside an ISO shipping container that is easy to relocate and CyptoKube can run inside a large warehouse, outside in a parking lot, or in a server pod farm where the power is cheapest. [EX1006, 1-4].

123. Thus, the combined device is mobile, and in order to save infrastructure costs and to avoid transporting the flare gas over a long distance, a POSITA would have found it obvious that the generator and blockchain mining devices are located adjacent to the facility (e.g., within one hundred meters).

124. For these reasons, I believe a POSITA would have understood that the Dickerson-CryptoKube combination discloses limitation [8].

f. Dependent Claim 16

“The system of claim 1 in which a controller is connected to operate a cooling system to maintain the blockchain mining devices within a predetermined operating range of temperature.”

125. The CryptoKube uses fans (fresh air cooling) to move large volumes of air through the data center to cool the servers and remove the hot air exhaust. [EX1006, 1, 4].

126. As shown in the CryptoKube video, the CryptoKube system includes a programmable logic controller (PLC) and a fan controller (which controls the speed of the fans), to keep the temperatures automatically. [EX1007, 0:05:41].



[EX1007, 0:05:41].

127. Further, as shown in the CryptoKube video, the CryptoKube system includes one or more temperature sensors to help maintain the operating temperature of the blockchain mining devices.



CryptoKube video, EX1023, 0:02:00

128. Thus, CryptoKube includes a controller that is connected to operate a cooling system to maintain the blockchain mining devices within a predetermined operating range of temperature.

129. For these reasons, I believe a POSITA would have understood that CryptoKube meets this limitation.

g. Dependent Claim 17

“The system of claim 1 in which the blockchain mining devices are housed in a portable enclosure that is structured to one or more of form a skid or be mounted on a trailer.”

130. Both the Dickerson system and the CryptoKube system are containerized and built inside an ISO shipping container to confer better mobility. [EX1005, [0014]; [EX1006, 1-4]. Thus, a POSITA would understand that it is easy to combine the two by simply combining two ISO

shipping containers into one. A POSITA would have been motivated to do so because it will save transportation costs. Dickerson discloses that the gas engine genset is compact, **containerized/skid mounted**, and mobile which makes the system particularly suitable for remote sites. [EX1005, [0027]]. Dickerson discloses that the mobile platform (container) is a part of a vehicle trailer. [EX1005, claim 3]. The CryptoKube video shows that the CryptoKube is built inside an ISO shipping container that is easy to relocate. [EX1006, 1-4].



CryptoKube video, EX1007, 0:01:08

131. Thus, in the combined device, the blockchain mining devices are housed in a portable enclosure that is structured to one or more of form a skid or be mounted on a trailer.

132. For these reasons, I believe a POSITA would have understood that the combined device discloses this limitation.

h. Dependent Claim 18

“The system of claim 17 in which the portable enclosure comprises a generator driven by an engine, which is connected to the source of combustible gas.”

133. Both the Dickerson system and the CryptoKube system are containerized and built inside an ISO shipping container to confer better mobility. [EX1005, [0014]]; [EX1006, 1-4]]. Thus, it is easy to combine the two by simply combining two ISO shipping containers into one. A POSITA would have been motivated to do so because it will save transportation costs. Per Dr. Nikolaou’s Declaration, Dickerson discloses that the gas engine genset is compact, **containerized/skid mounted**, and mobile which makes the system particularly suitable for remote sites. [EX1005, [0027]]. Dickerson discloses that the mobile platform (container) is a part of a vehicle trailer. [EX1005, claim 3].

134. Per Dr. Nikolaou’s Declaration, Dickerson’s system includes (1) one membrane separation unit for separating useful fuel gas from raw natural gas produced at an oil or gas production facility, (2) a gas engine that uses the fuel gas to generate electricity that is returned to the facility, and (3) a control panel for operating the apparatus. [EX1005, [0005]]. FIG. 1 of Dickerson shows one setup of its combined gas conditioning and power generation system. [EX1005, [0008]]. As shown in FIG. 1, gas genset 102 includes a gas engine 110 and a generator 112 that is driven by the engine 110. [EX1005, [0026]].

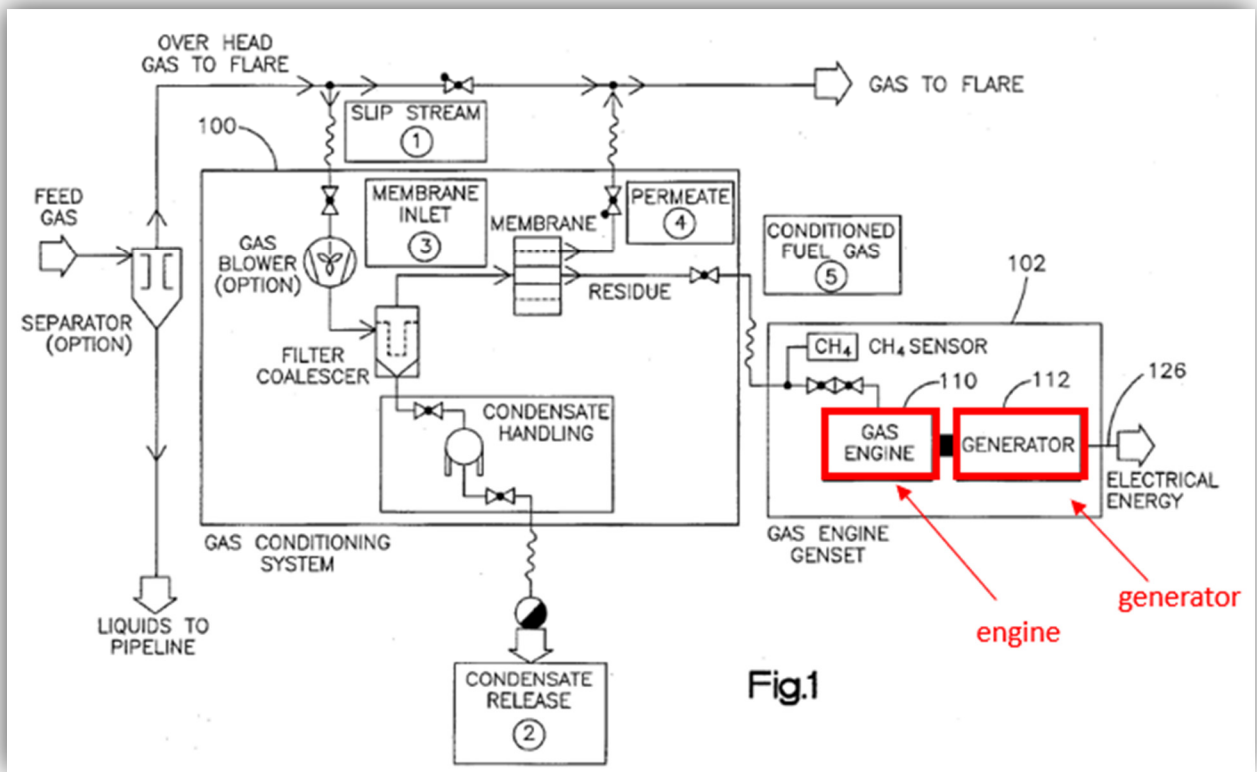

Fig.1

Dickerson, EX1005, FIG. 1 (annotated)

135. Thus, in the combined device, the portable enclosure (ISO container) comprises a generator driven by an engine, which is connected to the source of combustible gas.

136. For these reasons, I believe a POSITA would have understood that the combined device discloses this limitation.

i. Dependent Claim 19

“The system of any claim 18 in which the engine comprises a turbine.”

137. See Dr. Nikolaou’s declaration on Limitation [19].

j. Dependent Claim 20

“The system of claim 17 in which the portable enclosure comprises an intermodal transport container.”

138. Both the Dickerson system and the CryptoKube system are containerized and built inside an ISO shipping container to confer better mobility. [EX1005, [0014]]; [EX1006, 1-4]. Per Dr. Nikolaou's Declaration, Dickerson discloses that the gas engine genset is compact, containerized/skid mounted, and mobile which makes the system particularly suitable for remote sites. [EX1005, [0027]]. The CryptoKube video shows that the CryptoKube is built inside an ISO shipping container with walls, a top, and a base, with an access door formed in the walls.



CryptoKube video, EX1007, 0:01:08

139. Thus, in the combined device, the portable enclosure comprises an intermodal transport container (an ISO container).

140. For these reasons, I believe a POSITA would have understood that the combined device discloses this limitation.

k. **Dependent Claim 21**

“The system of claim 17 in which the portable enclosure has the form of a box with walls, a top, and a base, with one or more access doors formed in the walls.”

141. Both the Dickerson system and the CryptoKube system are containerized and built inside an ISO shipping container to confer better mobility. [EX1005, [0014]]; [EX1006, 1-4]. Per Dr. Nikolaou’s Declaration, Dickerson discloses that the gas engine genset is compact, containerized/skid mounted, and mobile which makes the system particularly suitable for remote sites. [EX1005, [0027]]. The CryptoKube video shows that the CryptoKube is built inside an ISO shipping container with walls, a top, and a base, with an access door formed in the walls.



CryptoKube video, EX1007, 0:01:08

142. Thus, in the combined device, the portable enclosure has the form of a box with walls, a top, and a base, with one or more access doors formed in the walls.

143. For these reasons, I believe a POSITA would have understood that the combined device discloses this limitation.

l. Dependent Claim 22

“The system of claim 1 further comprising a combustible gas disposal device, at the facility, the combustible gas disposal device being connected to receive combustible gas from the source of combustible gas.”

144. See Dr. Nikolaou’s declaration on Limitation [22].

m. Dependent Claim 23

“The system of claim 22 further comprising a valve connected upstream of the generator to receive the continuous flow of gas from the source of combustible gas, and selectively supply the continuous flow of gas to the generator, the combustible gas disposal device, or both the generator and the combustible gas disposal device, to selectively divert the continuous flow of gas to the combustible gas disposal device, the generator, or both the generator and the combustible gas disposal device, respectively.”

145. See Dr. Nikolaou’s declaration on Limitation [23].

n. Independent Claim 24

i. Limitation [24pre]

“A method comprising:”

146. To the extent the preamble is limiting, the Dickerson-CryptoKube combination renders [24pre] obvious. For example, Dickerson describes a method to generate electricity using flare gas (raw natural gas that is to be flared) at an oil and gas production facility. [EX1005, Abstract, [0002]].

ii. Limitation [24a]

“producing electricity using a generator and a source of combustible gas produced at a facility selected from the group consisting of a hydrocarbon production well, storage, or processing facility, and”

147. See Dr. Nikolaou’s declaration on Limitation [24a].

iii. Limitation [24b]

“operating blockchain mining devices located at the facility, respectively, using the electricity, in which:”

148. As discussed above, in the Dickerson-CryptoKube combination, the combined device would have (1) Dickerson’s mobile power generation system; and (2) CryptoKube’s mobile bitcoin miner, wherein the bitcoin mining devices (spondooliestech SP31 OR SP35 servers) are connected to and powered by Dickerson’s generator.

149. For these reasons, I believe a POSITA would have understood that the combined device discloses this limitation.

iv. Limitation [24c]

“the generator is connected to the source of combustible gas, in which the facility is connected to produce a continuous flow of combustible gas to power the generator;”

150. See Dr. Nikolaou’s declaration on Limitation [24c].

v. Limitation [24d_i]

“the blockchain mining devices each have a mining processor and are connected to a network interface;”

151. See discussion above regarding Limitation [ic_i].

vi. Limitation [24d_ii]

“the network interface is connected to receive and transmit data through the internet to a network that stores or has access to a blockchain database;”

152. See discussion above regarding Limitation [ic_ii].

vii. Limitation [24d_iii]

“the mining processors are connected to the network interface and adapted to mine transactions associated with the blockchain database and to communicate with the blockchain database;”

153. See discussion above regarding Limitation [1c_iii].

viii. Limitation [24d_iv]

“the network is a peer-to-peer network;”

154. See discussion above regarding Limitation [1c_iv].

ix. Limitation [24d_v]

“the blockchain database is a distributed database stored on plural nodes in the peer-to-peer network; and”

155. See discussion above regarding Limitation [1c_v].

x. Limitation [24d_vii]

“the blockchain database stores transactional information for a digital currency.”

156. See discussion above regarding Limitation [1c_vi].

o. Dependent Claim 25

The method of claim 24 further comprising, prior to using the source of combustible gas: one or both disconnecting or diverting the source of combustible gas from a combustible gas disposal device at the facility; and connecting the source of combustible gas to operate the blockchain mining devices.

157. See Dr. Nikolaou’s declaration on Limitation [25].

p. Dependent Claim 26

“The method of claim 25 in which the combustible gas disposal device comprises one or more of a flare, a vent to the atmosphere, an incinerator, or a burner.”

158. See Dr. Nikolaou’s declaration on Limitation [26].

q. Dependent Claim 27

“The method of claim 24 further comprising: connecting the source of combustible gas to operate the blockchain mining devices; and diverting gas from a combustible gas disposal device to operate the blockchain mining devices.”

159. See Dr. Nikolaou’s declaration on Limitation [27].

r. Dependent Claim 28

“The method of claim 24 in which the facility is selected from a group consisting of an oil or gas well that is isolated from a sales gas line and an external electrical power grid.”

160. See Dr. Nikolaou’s declaration on Limitation [28].

s. Dependent Claim 29

“The method of claim 24 in which the source of combustible gas is a remote well selected from a group consisting of a remote oil or gas well.”

161. See Dr. Nikolaou’s declaration on Limitation [29].

t. Dependent Claim 30

“The method of claim 24 in which producing further comprises supplying combustible gas to a combustion engine that is connected to drive the generator.”

162. See Dr. Nikolaou’s declaration on Limitation [30].

u. Dependent Claim 34

“The method of claim 29 further comprising operating the blockchain mining devices to: mine transactions with the blockchain mining devices; and communicate wirelessly through the internet to communicate with a blockchain database.”

163. As discussed above regarding [24d_iii], the mining processors are connected to the network interface and adapted to mine transactions associated with the blockchain database and to communicate with the blockchain database. A POSITA would have found it obvious that the network interface connection is a wireless connection. For example, Kheterpal discloses that “[n]odes 10 of network 100 may be coupled via any desired underlying communications technology such as wired or wireless network technologies.” [EX1010, [0030]]. Thus, using a wireless network connection is an obvious design choice.

164. For these reasons, I believe a POSITA would have found this limitation obvious.

XIV. ANALYSIS OF DICKERSON, CRYPTOKUBE, AND BELADY-989 (GROUND 2)

165. For the reasons articulated in detail below, and based on my review of the ’372 patent, the file history, the prior art cited here, Dr. Michael Nikolaou’s Declaration, and my years of experience in the bitcoin mining industry, a POSITA would have readily understood that claims 1-4, 8, 10-12, 15-30, 34-37, and 40 are obvious over the combination of Dickerson, CryptoKube, and Belady-989, in view of Szmigielski and Kheterpal.

A. It Would Have Been Obvious to a POSITA to Combine Dickerson,

CryptoKube, and Belady-989 in view of Szmigielski and Kheterpal.

166. A POSITA would have found it obvious to combine Dickerson's mobile power generation system, CryptoKube's mobile bitcoin miner, wherein the bitcoin mining devices (spondooliestech SP31 OR SP35 servers) are connected to and powered by Dickerson's generator, and Belady-989's gas supply shock absorbers, in view of Szmigielski and Kheterpal.

167. As discussed above, Dickerson's system generates free excess electricity and Szmigielski discloses that one of the biggest costs for Bitcoin miners is the cost of electricity and access to cheap power is desired. [EX1009, 90].

168. Thus, a POSITA would have found it obvious to couple the CryptoKube mobile bitcoin miner with Dickerson's system to utilize the free excess electricity.

169. Both the Dickerson system and the CryptoKube system are containerized and built inside an ISO shipping container to confer better mobility. [EX1005, [0014]]; [EX1006, 1-4]. Thus, it is easy to combine the two by simply combining two ISO shipping containers into one.

170. In the Dickerson-CryptoKube combination, the combined device would have (1) Dickerson's mobile power generation system; and (2) CryptoKube's mobile bitcoin miner, wherein the bitcoin mining devices (spondooliestech SP31 OR SP35 servers) are connected to and powered by Dickerson's generator.

171. Per Dr. Nikolaou's Declaration, Belady-989 describes a gas supply shock absorber (containing a gas storage) that is used to improve a data center system powered by a natural gas generator. [EX1011, Abstract]. If the shock absorber has sufficient gas, a co-located data center utilizes such gas for increased electrical power generation during increased processing activity, which can be requested or generated. [EX1011, Abstract]. Conversely, if the shock absorber has insufficient gas, and a negative pressure spike occurs, the data center throttles down or offloads processing. [EX1011, Abstract].

172. Per Dr. Nikolaou's Declaration, Dickerson discloses that "auxiliary means for providing electricity is provided when there will likely be periods when the production facility will require electricity but will be generating no or low levels of raw natural gas." [EX1005, [0021]]. A POSITA would have understood that the flow of raw natural gas from the oil and gas facility may fluctuate and would have been motivated to further improve the Dickerson-CryptoKube combination by employing Belady-989's gas supply shock absorber because doing so will improve the energy usage efficiency. Indeed, Belady-989 discloses data centers often consume large quantities of electrical power, and should be located in areas where natural resources (e.g., flare gas), from which electrical power can be derived, are abundant and can be obtained inexpensively. [EX1011, [0004]]. Szmigielski also discloses that "[i]ndustrial miners face almost the same issues as data centers: access to relatively cheap power, good network access..." [EX1009, 103].

173. Thus, a POSITA would have been motivated to combine Dickerson, CryptoKube and Belady-989, to use Belady-989's gas supply shock absorber to improve energy usage efficiency.

174. In the Dickerson-CryptoKube-Belady-989 combination, the combined device would have (1) Dickerson's mobile power generation system; (2) CryptoKube's mobile bitcoin miner, wherein the bitcoin mining devices (spondooliestech SP31 OR SP35 servers) are connected to and powered by Dickerson's generator; and (3) Belady-989's gas supply shock absorber.

B. The Combination of Dickerson, CryptoKube, and Belady-989 Renders Claims 1-4, 8, 10-12, 15-30, 34-37, and 40 Obvious.

175. As I explain below, the combination of Dickerson, CryptoKube, and Belady-989 renders obvious all limitations of claims 1-4, 8, 10-12, 15-30, 34-37, and 40. As stated above, I relied on Dr. Michael Nikolaou's opinions and explanations related to Dickerson and Belady-989 for the purposes of this Declaration.

a. **Independent Claim 1**

i. ***Limitation [1pre]***

“A system comprising:”

176. As I explained above in Ground 1, to the extent the preamble is limiting, combining Dickerson and CryptoKube renders [1pre] obvious. *See* discussion in Ground 1.

ii. ***Limitation [1a]***

“a source of combustible gas produced from a facility selected from a group consisting of a hydrocarbon production, storage, or processing facility;”

177. *See* Dr. Nikolaou’s declaration on Limitation [1a].

iii. ***Limitation [1b]***

“a generator connected to the source of combustible gas to receive a continuous flow of combustible gas to power the generator; and”

178. *See* Dr. Nikolaou’s declaration on Limitation [1b].

iv. ***Limitation [1c]***

“blockchain mining devices connected to the generator; in which:”

179. As I explained above in Ground 1, and for the reasons provided by Dr. Nikolaou, I believe a POSITA would have understood that combining Dickerson and CryptoKube meets this limitation.

v. ***Limitation [1c_i]***

“the blockchain mining devices each have a mining processor and are connected to a network interface;”

180. *See* discussion above in Ground 1 on Limitation [1c_i].

181. Further, Belady-989 discloses that “the data center 190 can comprise a communication connection 191 to a network 199.” [EX1011, [0029]].

vi. ***Limitation [1c_ii]***

“the network interface is connected to receive and transmit data through the internet to a network that stores or has access to a blockchain database;”

182. See discussion above in Ground 1 on Limitation [1c_ii].

vii. Limitation [1c_iii]

“the mining processors are connected to the network interface and adapted to mine transactions associated with the blockchain database and to communicate with the blockchain database;”

183. See discussion above in Ground 1 on Limitation [1c_iii].

viii. Limitation [1c_iv]

“the network is a peer-to-peer network;”

184. See discussion above in Ground 1 on Limitation [1c_iv].

ix. Limitation [1c_v]

“the blockchain database is a distributed database stored on plural nodes in the peer-to-peer network; and”

185. See discussion above in Ground 1 on Limitation [1c_v].

x. Limitation [1c_vi]

“the blockchain database stores transactional information for a digital currency.”

186. See discussion above in Ground 1 on Limitation [1c_vi].

b. Dependent Claim 2

“The system of claim 1 isolated from a sales gas line and an external electrical power grid.”

187. See Dr. Nikolaou’s declaration on Limitation [2].

c. Dependent Claim 3

“The system of claim 1 in which: the source of combustible gas and the facility comprise a remote well selected from a group consisting of a remote oil or gas well; and the remote well is connected to produce the continuous flow of combustible gas to power the generator.”

188. See Dr. Nikolaou’s declaration on Limitation [3].

d. Dependent Claim 4

“The system of claim 3 further comprising a combustion engine connected to the source of combustible gas and connected to drive the generator.”

189. See Dr. Nikolaou’s declaration on Limitation [4].

e. Dependent Claim 8

“The system of claim 1 in which the generator and blockchain mining devices are located adjacent to the facility.”

190. See discussion above in Ground 1 on Limitation [8].

f. Dependent Claim 10

“The system of claim 1 in which the system is configured to modulate a power load level exerted by the blockchain mining devices on the generator, by increasing or decreasing the mining activity of the mining processor.”

191. As discussed above, in the Dickerson-CryptoKube-Belady-989 combination, the combined device would have (1) Dickerson’s mobile power generation system; (2) CryptoKube’s mobile bitcoin miner, wherein the bitcoin mining devices (spondooliestech SP31 OR SP35 servers) are connected to and powered by Dickerson’s generator; and (3) Belady-989’s gas supply shock absorber.

192. Per Dr. Nikolaou’s Declaration, Belady-989 describes a gas supply shock absorber (containing a gas storage) that is used to improve a data center system powered by a natural gas generator. [EX1011, Abstract]. If the shock absorber has sufficient gas, a co-located data center utilizes such gas for increased electrical power generation during increased processing activity, which can be requested or generated. [EX1011, Abstract]. Conversely, if the shock absorber has insufficient gas, and a negative pressure spike occurs, the data center throttles down or offloads processing. [EX1011, Abstract]. CryptoKube contains a monitoring server running a DCIM software that can be customized to monitor and control the individual miners. [EX1023, 0:00:08]. A POSITA would have found it obvious to adapt CryptoKube’s DCIM software to adjust the

mining activity of the mining processors (e.g., by turning off a certain number of mining processors) based on input from Belady-989's tank pressure sensor.

193. Thus, in the Dickerson-CryptoKube-Belady-989 combination, the system is configured to modulate a power load level exerted by the blockchain mining devices on the generator, by increasing or decreasing the mining activity of the mining processor.

194. For these reasons, and for the reasons provided by Dr. Nikolaou, I believe a POSITA would have understood that the combined device discloses this limitation.

g. Dependent Claim 11

“The system of claim 10 in which the system is configured to modulate the power load level by selecting one or more actions from a group of actions consisting of increasing or decreasing a maximum number of mining processors that are engaged in mining transactions.”

195. A POSITA would have found it obvious to adapt CryptoKube's DCIM software to adjust the mining activity of the mining processors (e.g., by turning off a certain number of mining processors) based on input from Belady-989's tank pressure sensor. For example, a POSITA would have found it obvious to adjust the mining activity of the mining processors by increasing or decreasing a maximum number of mining processors that are engaged in mining transactions.

196. *See* Dr. Nikolaou's declaration on Limitation [11].

h. Dependent Claim 12

“The system of claim 10 in which the system is configured to modulate the power load level in response to variations in a production rate of combustible gas from the hydrocarbon production well, storage, or processing facility.”

197. As I stated above, a POSITA would have found it obvious to adapt CryptoKube's DCIM software to adjust the mining activity of the mining processors (e.g., by turning off a certain number of mining processors) based on input from Belady-989's tank pressure sensor.

198. Per Dr. Nikolaou's Declaration, Belady-989 discloses that its gas supply shock absorber comprises pressure sensing valves and pressure regulating valves, which can detect positive pressure spikes in the gas supply and enable such overly pressurized gas to charge the gas storage, and which can also detect negative pressure spikes in the gas supply and, in response, make available the gas stored in the gas storage to compensate for such negative pressure spikes. [EX1011, [0015]]. Belady-989 further discloses that if the gas storage has a sufficient quantity of gas stored therein, the data center can utilize such gas to provide increased electrical power during periods of increased processing activity and workload. [EX1011, [0015]]. Conversely, if the gas storage has an insufficient quantity of gas stored therein, and the gas supply experiences a negative pressure spike, the computing devices of the data center can be throttled down to consume less electrical power. [EX1011, [0015]]. A POSITA would have found it obvious that Belady-989's gas pressure sensor regulates the power load level of the bitcoin miners (e.g., by turning off a certain number of mining processors) based on input from Belady-989's tank pressure sensor in response to variations in a production rate of combustible gas.

199. Thus, in the Dickerson-CryptoKube-Belady-989 combination, the system is configured to modulate the power load level in response to variations in a production rate of combustible gas from the hydrocarbon production well, storage, or processing facility.

200. For these reasons, and for the reasons provided by Dr. Nikolaou, I believe a POSITA would have understood that the combined device discloses this limitation.

i. Dependent Claim 15

"The system of claim 10 in which: a production rate of combustible gas from the hydrocarbon production well, storage, or processing facility varies between a daily minimum production rate and a daily maximum production rate; the controller is set to limit the power load level to above a power level producible by the generator when the production rate is at the daily minimum production rate; and a backup source, selected from a group consisting of fuel or electricity, is connected make up a shortfall in fuel

or electricity, respectively, required to supply the blockchain mining devices with the power load level.”

201. As I stated above, a POSITA would have found it obvious to adapt CryptoKube’s DCIM software to adjust the mining activity of the mining processors (e.g., by turning off a certain number of mining processors) based on input from Belady-989’s tank pressure sensor.

202. See Dr. Nikolaou’s declaration on Limitation [15].

j. Dependent Claim 16

“The system of claim 1 in which a controller is connected to operate a cooling system to maintain the blockchain mining devices within a predetermined operating range of temperature.”

203. See discussion in Ground 1 on Limitation [16].

k. Dependent Claim 17

“The system of claim 1 in which the blockchain mining devices are housed in a portable enclosure that is structured to one or more of form a skid or be mounted on a trailer.”

204. See discussion in Ground 1 on Limitation [17].

l. Dependent Claim 18

“The system of claim 17 in which the portable enclosure comprises a generator driven by an engine, which is connected to the source of combustible gas.”

205. See discussion in Ground 1 on Limitation [18].

m. Dependent Claim 19

“The system of any claim 18 in which the engine comprises a turbine.”

206. See Dr. Nikolaou’s declaration on Limitation [19].

n. Dependent Claim 20

“The system of claim 17 in which the portable enclosure comprises an intermodal transport container.”

207. See discussion in Ground 1 on Limitation [20].

o. Dependent Claim 21

“The system of claim 17 in which the portable enclosure has the form of a box with walls, a top, and a base, with one or more access doors formed in the walls.”

208. See discussion in Ground 1 on Limitation [21].

p. Dependent Claim 22

“The system of claim 1 further comprising a combustible gas disposal device, at the facility, the combustible gas disposal device being connected to receive combustible gas from the source of combustible gas.”

209. See Dr. Nikolaou’s declaration on Limitation [22].

q. Dependent Claim 23

“The system of claim 22 further comprising a valve connected upstream of the generator to receive the continuous flow of gas from the source of combustible gas, and selectively supply the continuous flow of gas to the generator, the combustible gas disposal device, or both the generator and the combustible gas disposal device, to selectively divert the continuous flow of gas to the combustible gas disposal device, the generator, or both the generator and the combustible gas disposal device, respectively.”

210. See Dr. Nikolaou’s declaration on Limitation [23].

r. Independent Claim 24

i. *Limitation [24pre]*

“A method comprising:”

211. See discussion in Ground 1.

ii. *Limitation [24a]*

“producing electricity using a generator and a source of combustible gas produced at a facility selected from the group consisting of a hydrocarbon production well, storage, or processing facility, and”

212. See Dr. Nikolaou’s declaration on Limitation [24a].

iii. *Limitation [24b]*

“operating blockchain mining devices located at the facility, respectively, using the electricity, in which:”

213. See discussion in Ground 1.

iv. Limitation [24c]

“the generator is connected to the source of combustible gas, in which the facility is connected to produce a continuous flow of combustible gas to power the generator;”

214. See Dr. Nikolaou’s declaration on Limitation [24c].

v. Limitation [24d_i]

“the blockchain mining devices each have a mining processor and are connected to a network interface;”

215. See discussion in Ground 1 on Limitation [1c_i].

216. Further, Belady-989 discloses that “the data center 190 can comprise a communication connection 191 to a network 199.” [EX1011, [0029]].

vi. Limitation [24d_ii]

“the network interface is connected to receive and transmit data through the internet to a network that stores or has access to a blockchain database;”

217. See discussion in Ground 1 on Limitation [1c_ii].

vii. Limitation [24d_iii]

“the mining processors are connected to the network interface and adapted to mine transactions associated with the blockchain database and to communicate with the blockchain database;”

218. See discussion in Ground 1 on Limitation [1c_iii].

viii. Limitation [24d_iv]

“the network is a peer-to-peer network;”

219. See discussion in Ground 1 on Limitation [1c_iv].

ix. Limitation [24d_v]

“the blockchain database is a distributed database stored on plural nodes in the peer-to-peer network; and”

220. See discussion in Ground 1 on Limitation [1c_v].

x. Limitation [24d_vi]

“the blockchain database stores transactional information for a digital currency.”

221. See discussion in Ground 1 on Limitation [1c_vi].

s. Dependent Claim 25

“The method of claim 24 further comprising, prior to using the source of combustible gas: one or both disconnecting or diverting the source of combustible gas from a combustible gas disposal device at the facility; and connecting the source of combustible gas to operate the blockchain mining devices.”

222. See Dr. Nikolaou’s declaration on Limitation [25].

t. Dependent Claim 26

“The method of claim 25 in which the combustible gas disposal device comprises one or more of a flare, a vent to the atmosphere, an incinerator, or a burner.”

223. See Dr. Nikolaou’s declaration on Limitation [26].

u. Dependent Claim 27

“The method of claim 24 further comprising: connecting the source of combustible gas to operate the blockchain mining devices; and diverting gas from a combustible gas disposal device to operate the blockchain mining devices.”

224. See Dr. Nikolaou’s declaration on Limitation [27].

v. Dependent Claim 28

“The method of claim 24 in which the facility is selected from a group consisting of an oil or gas well that is isolated from a sales gas line and an external electrical power grid.”

225. See Dr. Nikolaou’s declaration on Limitation [28].

w. Dependent Claim 29

“The method of claim 24 in which the source of combustible gas is a remote well selected from a group consisting of a remote oil or gas well.”

226. See Dr. Nikolaou’s declaration on Limitation [29].

x. Dependent Claim 30

“The method of claim 24 in which producing further comprises supplying combustible gas to a combustion engine that is connected to drive the generator.”

227. See Dr. Nikolaou's declaration on Limitation [29].

y. **Dependent Claim 34**

"The method of claim 29 further comprising operating the blockchain mining devices to: mine transactions with the blockchain mining devices; and communicate wirelessly through the internet to communicate with a blockchain database."

228. See discussion above in Ground 1 on Limitation [34].

z. **Dependent Claim 35**

"The method of claim 34 further comprising modulating a power load level exerted by the blockchain mining devices on the generator, by selecting an action from a group of actions consisting of increasing or decreasing, a mining activity of the blockchain mining devices."

229. See discussion above in Ground 2 on Limitation [10].

aa. **Dependent Claim 36**

"The method of claim 35 in which: modulating comprises modulating the power load level by increasing or decreasing a maximum number of mining processors that are engaged in mining transactions."

230. See discussion above in Ground 2 on Limitation [11].

bb. **Dependent Claim 37**

"The method of claim 36 in which modulating comprises modulating the power load level in response to variations in a production rate of combustible gas from the hydrocarbon production well, storage, or processing facility."

231. See discussion above in Ground 2 on Limitation [12].

cc. **Dependent Claim 40**

"The method of claim 35 in which: a production rate of combustible gas from the hydrocarbon production well, storage, or processing facility varies between a daily minimum production rate and a daily maximum production rate; modulating comprises limiting the power load level to above a power level produced by the generator when the production rate is at the daily minimum production rate; and supplying from a backup source, which is selected from a group consisting of a backup fuel or electricity source a shortfall in fuel or electricity, respectively, required to supply the blockchain mining devices with the power load level."

232. See discussion above in Ground 2 on Limitation [15].

XV. ANALYSIS OF DICKERSON, CRYPTOKUBE, BELADY-989, AND BOOT (GROUND 3)

233. For the reasons articulated in detail below, and based on my review of the '372 patent, the file history, the prior art cited here, Dr. Michael Nikolaou's declaration, and my years of experience in the bitcoin mining industry, a POSITA would have readily understood that claims 1-4, 7-12, 15-30, 34-37, and 40 are obvious over the combination of Dickerson, CryptoKube, Belady-989, and Boot, in view of Szmigielski and Kheterpal.

A. It Would Have Been Obvious to a POSITA to Combine Dickerson, CryptoKube, Belady-989, and Boot in view of Szmigielski and Kheterpal.

234. A POSITA would have found it obvious to improve the Dickerson-CryptoKube-Belady-989 combination by further including Boot's teachings, including using Boot's load bank to absorb excess power, and gathering oil and gas from multiple wells on a multi-well, and in view of Szmigielski and Kheterpal.

235. Similar to Dickerson, Boot discloses a mobile power generation system that can generate electricity using flare gas (raw natural gas that is to be flared) at an oil and gas production facility that is isolated from a power grid. [EX1012, Abstract, 1:5-10, 4:6-7]. Boot discloses that the power generated may be more than the power required on an oil field pumping site, and that the excess power can be dissipated as heat in a load bank 110. [EX1012, 3:8-14]. Boot further discloses in FIG. 2 that the flare gas can be derived from more than one oil pumps or more than one well heads. [EX1012, FIG. 2, 3:42-46].

236. A POSITA would have found it obvious to improve the Dickerson-CryptoKube-Belady-989 combination by further including Boot's teachings including using Boot's load bank to absorb excess power, and gathering oil and gas from multiple wells on a multi-well pad.

237. A POSITA would have been motivated to include Boot’s load bank because Boot teaches that the load bank can help keep the engine within its preferred operating parameters (for instance not running at too low a speed and hence too low a temperature). [EX1012, 3:8-14].

238. A POSITA would have been motivated to gather oil and gas from multiple wells on a multi-well pad because doing so can increase gas supply and increase the amount of electricity generated.

B. The Combination of Dickerson, CryptoKube, Belady-989, and Boot Renders Claims 1-4, 7-12, 15-30, 34-37, and 40 Obvious.

239. As I explain below, the combination of Dickerson, CryptoKube, Belady-989, and Boot renders obvious all limitations of claims 1-4, 7-12, 15-30, 34-37, and 40. As stated above, I relied on Dr. Michael Nikolaou’s opinions and explanations related to Dickerson, Belady-989, and Boot for the purposes of this Declaration.

a. Independent Claim 1

i. *Limitation [1pre]*

“A system comprising:”

240. To the extent the preamble is limiting, the Dickerson-CryptoKube-Belady-989-Boot combination renders [1pre] obvious. For example, Boot describes a mobile power generation system that can generate electricity using flare gas (raw natural gas that is to be flared) at an oil and gas production facility. [EX1012, Abstract, 1:5-10, 4:6-7]. CryptoKube also discloses a bitcoin miner system. [EX1006, 1-4].

ii. *Limitation [1a]*

“a source of combustible gas produced from a facility selected from a group consisting of a hydrocarbon production, storage, or processing facility;”

241. See Dr. Nikolaou’s declaration on Limitation [1a].

iii. *Limitation [1b]*

“a generator connected to the source of combustible gas to receive a continuous flow of combustible gas to power the generator; and”

242. See Dr. Nikolaou’s declaration on Limitation [1b].

iv. Limitation [1c]

“blockchain mining devices connected to the generator; in which:”

243. See Ground 2 above.

v. Limitation [1c_i]

“the blockchain mining devices each have a mining processor and are connected to a network interface;”

244. See Ground 2 above.

vi. Limitation [1c_ii]

“the network interface is connected to receive and transmit data through the internet to a network that stores or has access to a blockchain database;”

245. See Ground 2 above.

vii. Limitation [1c_iii]

“the mining processors are connected to the network interface and adapted to mine transactions associated with the blockchain database and to communicate with the blockchain database;”

246. See Ground 2 above.

viii. Limitation [1c_iv]

“the network is a peer-to-peer network;”

247. See Ground 2 above.

ix. Limitation [1c_v]

“the blockchain database is a distributed database stored on plural nodes in the peer-to-peer network; and”

248. See Ground 2 above.

x. Limitation [1c_vi]

“the blockchain database stores transactional information for a digital currency.”

249. See Ground 2 above.

b. Dependent Claim 2

“The system of claim 1 isolated from a sales gas line and an external electrical power grid.”

250. See Dr. Nikolaou’s declaration on Limitation [2].

c. Dependent Claim 3

“The system of claim 1 in which: the source of combustible gas and the facility comprise a remote well selected from a group consisting of a remote oil or gas well; and the remote well is connected to produce the continuous flow of combustible gas to power the generator.”

251. See Dr. Nikolaou’s declaration on Limitation [3].

d. Dependent Claim 4

“The system of claim 3 further comprising a combustion engine connected to the source of combustible gas and connected to drive the generator.”

252. See Dr. Nikolaou’s declaration on Limitation [4].

e. Dependent Claim 7

“The system of claim 1 in which: the facility comprises a unit selected from a group consisting of an oil storage or processing unit; the source of combustible gas comprises the unit, which has a gas outlet connected to supply combustible gas to operate the generator; and the unit is connected to receive oil produced from a remote oil well.”

253. See Dr. Nikolaou’s declaration on Limitation [7].

f. Dependent Claim 8

“The system of claim 1 in which the generator and blockchain mining devices are located adjacent to the facility.”

254. See Ground 2 above.

g. Dependent Claim 9

“The system of claim 1 in which the facility comprises a plurality of remote wells selected from a group consisting of remote oil or gas wells, and one or both of the

following conditions are satisfied: the plurality of remote wells are located on a multi-well pad; or the plurality of remote wells include a satellite well.”

255. *See* Dr. Nikolaou’s declaration on Limitation [9].

h. Dependent Claim 10

“The system of claim 1 in which the system is configured to modulate a power load level exerted by the blockchain mining devices on the generator, by increasing or decreasing the mining activity of the mining processor.”

256. *See* Ground 2 above.

i. Dependent Claim 11

“The system of claim 10 in which the system is configured to modulate the power load level by selecting one or more actions from a group of actions consisting of increasing or decreasing a maximum number of mining processors that are engaged in mining transactions.”

257. *See* Ground 2 above.

j. Dependent Claim 12

“The system of claim 10 in which the system is configured to modulate the power load level in response to variations in a production rate of combustible gas from the hydrocarbon production well, storage, or processing facility.”

258. *See* Ground 2 above.

k. Dependent Claim 15

“The system of claim 10 in which: a production rate of combustible gas from the hydrocarbon production well, storage, or processing facility varies between a daily minimum production rate and a daily maximum production rate; the controller is set to limit the power load level to above a power level producible by the generator when the production rate is at the daily minimum production rate; and a backup source, selected from a group consisting of fuel or electricity, is connected make up a shortfall in fuel or electricity, respectively, required to supply the blockchain mining devices with the power load level.”

259. *See* Ground 2 above.

l. Dependent Claim 16

“The system of claim 1 in which a controller is connected to operate a cooling system to maintain the blockchain mining devices within a predetermined operating range of temperature.”

260. See Ground 2 above.

m. Dependent Claim 17

“The system of claim 1 in which the blockchain mining devices are housed in a portable enclosure that is structured to one or more of form a skid or be mounted on a trailer.”

261. See Ground 2 above.

n. Dependent Claim 18

“The system of claim 17 in which the portable enclosure comprises a generator driven by an engine, which is connected to the source of combustible gas.”

262. See Ground 2 above.

o. Dependent Claim 19

“The system of any claim 18 in which the engine comprises a turbine.”

263. See Dr. Nikolaou’s declaration on Limitation [19].

p. Dependent Claim 20

“The system of claim 17 in which the portable enclosure comprises an intermodal transport container.”

264. See Ground 2 above.

q. Dependent Claim 21

“The system of claim 17 in which the portable enclosure has the form of a box with walls, a top, and a base, with one or more access doors formed in the walls.”

265. See Ground 2 above.

r. Dependent Claim 22

“The system of claim 1 further comprising a combustible gas disposal device, at the facility, the combustible gas disposal device being connected to receive combustible gas from the source of combustible gas.”

266. See Ground 2 above.

s. Dependent Claim 23

“The system of claim 22 further comprising a valve connected upstream of the generator to receive the continuous flow of gas from the source of combustible gas, and

selectively supply the continuous flow of gas to the generator, the combustible gas disposal device, or both the generator and the combustible gas disposal device, to selectively divert the continuous flow of gas to the combustible gas disposal device, the generator, or both the generator and the combustible gas disposal device, respectively.”

267. See Ground 2 above.

t. **Independent Claim 24**

i. ***Limitation [24pre]***

“A method comprising:”

268. See Ground 2 above.

ii. ***Limitation [24a]***

“producing electricity using a generator and a source of combustible gas produced at a facility selected from the group consisting of a hydrocarbon production well, storage, or processing facility, and”

269. See Dr. Nikolaou’s declaration on Limitation [24a].

iii. ***Limitation [24b]***

“operating blockchain mining devices located at the facility, respectively, using the electricity, in which:”

270. See Ground 2 above.

iv. ***Limitation [24c]***

“the generator is connected to the source of combustible gas, in which the facility is connected to produce a continuous flow of combustible gas to power the generator;”

271. See Dr. Nikolaou’s declaration on Limitation [24c].

v. ***Limitation [24d_i]***

“the blockchain mining devices each have a mining processor and are connected to a network interface;”

272. See Ground 2 above.

273. Further, Belady-989 discloses that “the data center 190 can comprise a communication connection 191 to a network 199.” [EX1011, [0029]].

vi. Limitation [24d_ii]

“the network interface is connected to receive and transmit data through the internet to a network that stores or has access to a blockchain database;”

274. See Ground 2 above.

vii. Limitation [24d_iii]

“the mining processors are connected to the network interface and adapted to mine transactions associated with the blockchain database and to communicate with the blockchain database;”

275. See Ground 2 above.

viii. Limitation [24d_iv]

“the network is a peer-to-peer network;”

276. See Ground 2 above.

ix. Limitation [24d_v]

“the blockchain database is a distributed database stored on plural nodes in the peer-to-peer network; and”

277. See Ground 2 above.

x. Limitation [24d_vi]

“the blockchain database stores transactional information for a digital currency.”

278. See Ground 2 above.

u. Dependent Claim 25

“The method of claim 24 further comprising, prior to using the source of combustible gas: one or both disconnecting or diverting the source of combustible gas from a combustible gas disposal device at the facility; and connecting the source of combustible gas to operate the blockchain mining devices.”

279. See Ground 2 above.

v. Dependent Claim 26

“The method of claim 25 in which the combustible gas disposal device comprises one or more of a flare, a vent to the atmosphere, an incinerator, or a burner.”

280. See Ground 2 above.

w. Dependent Claim 27

“The method of claim 24 further comprising: connecting the source of combustible gas to operate the blockchain mining devices; and diverting gas from a combustible gas disposal device to operate the blockchain mining devices.”

281. See Ground 2 above.

x. Dependent Claim 28

“The method of claim 24 in which the facility is selected from a group consisting of an oil or gas well that is isolated from a sales gas line and an external electrical power grid.”

282. See Dr. Nikolaou’s declaration on Limitation [28].

y. Dependent Claim 29

“The method of claim 24 in which the source of combustible gas is a remote well selected from a group consisting of a remote oil or gas well.”

283. See Dr. Nikolaou’s declaration on Limitation [29].

z. Dependent Claim 30

“The method of claim 24 in which producing further comprises supplying combustible gas to a combustion engine that is connected to drive the generator.”

284. See Dr. Nikolaou’s declaration on Limitation [30].

aa. Dependent Claim 34

“The method of claim 29 further comprising operating the blockchain mining devices to: mine transactions with the blockchain mining devices; and communicate wirelessly through the internet to communicate with a blockchain database.”

285. See Ground 2 above.

bb. Dependent Claim 35

“The method of claim 34 further comprising modulating a power load level exerted by the blockchain mining devices on the generator, by selecting an action from a group of

actions consisting of increasing or decreasing, a mining activity of the blockchain mining devices.”

286. *See* discussion above regarding limitation [10.0].

cc. Dependent Claim 36

“The method of claim 35 in which: modulating comprises modulating the power load level by increasing or decreasing a maximum number of mining processors that are engaged in mining transactions.”

287. *See* discussion above regarding limitation [11.0].

dd. Dependent Claim 37

“The method of claim 36 in which modulating comprises modulating the power load level in response to variations in a production rate of combustible gas from the hydrocarbon production well, storage, or processing facility.”

288. *See* discussion above regarding limitation [12.0].

ee. Dependent Claim 40

“The method of claim 35 in which: a production rate of combustible gas from the hydrocarbon production well, storage, or processing facility varies between a daily minimum production rate and a daily maximum production rate; modulating comprises limiting the power load level to above a power level produced by the generator when the production rate is at the daily minimum production rate; and supplying from a backup source, which is selected from a group consisting of a backup fuel or electricity source a shortfall in fuel or electricity, respectively, required to supply the blockchain mining devices with the power load level.”

289. *See* discussion above regarding limitation [15.0].

XVI. ANALYSIS OF PIONEER ENERGY’S MAGS SYSTEM AND THE POLIVKA MINER (GROUND 4)

290. For the reasons articulated in detail below, and based on my review of the ’372 patent, the file history, the prior art cited here, Dr. Michael Nikolaou’s Declaration, and my years of experience in the bitcoin mining industry, a POSITA would have readily understood that claims 1-4, 8, 8, 16-30, and 34 are obvious over the combination of Pioneer Energy’s MAGS System and the Polivka miner, in view of Szmigielski and Kheterpal.

A. It Would Have Been Obvious to a POSITA to Combine Pioneer Energy’s

MAGS System and the Polivka Miner in view of Szmigielski and Kheterpal.

291. A POSITA would have found it obvious to combine the MAGS mobile power generation system and the Polivka mobile bitcoin miner, wherein the bitcoin mining devices (e.g., spondooliestech SP31 servers) are connected to and powered by the MAGS mobile power generation system, and in view of Szmigielski and Kheterpal.

292. Pioneer Energy's Mobile Alkane Gas Separator (MAGS) system separates **flare gases** that naturally occur at drilling sites into three streams: one can be captured in tanks and shipped off for sale, another **powers generators** that run the drilling operation, and a third powers MAGS itself. [EX1013, 2].

293. Thus, a POSITA would have understood that MAGS can produce cheap or free electricity using flare gases that would be otherwise flared at the well site.

294. Szmigielski discloses that one of the biggest costs for Bitcoin miners is the cost of electricity and access to cheap power is desired. [EX1009, 90]. The Bitcointalk forum post also explains that cheap electricity is desired and even required to run the bitcoin miner. [EX1015, 15, 21].

295. Thus, a POSITA would have been motivated to couple a bitcoin miner to MAGS to utilize the cheap or free electricity generated from flare gas.

296. Polivka discloses a mobile bitcoin miner that can be easily transported to a remote oil and gas production facility. [EX1015, 1-10]. The Bitcointalk forum post also envisions powering the Polivka miner by gas using a combustion engine. [EX1015, 18].

297. Thus, a POSITA would have found it obvious to couple the Polivka system with the MAGS system to utilize the cheap/free electricity.

298. Both the MAGS system and the Polivka system are containerized to confer better mobility. [EX1014, [0162], FIG. 4]; [EX1015, 1-10]. Thus, it is easy to combine the two by simply

combining two containerized mobile systems into one. A POSITA would have had a reasonable expectation of success in the combination at least because “the first MAGS field unit was tested in the spring of 2014 and units were sent to North Dakota later that fall.” [EX1013, 3].

299. In the MAGS-Polivka combination, the combined device would have (1) the MAGS mobile power generation system; and (2) the Polivka mobile bitcoin miner, wherein the bitcoin mining devices (e.g., spondooliestech SP31 OR SP35 servers) are connected to and powered by the MAGS mobile power generation system.

B. The Combination of Pioneer Energy’s MAGS System and the Polivka Miner Renders Claims 1-4, 8, 16-30, and 34 Obvious.

300. As I explain below, the combination of Pioneer Energy’s MAGS System and the Polivka miner renders obvious all limitations of claims 1-4, 16-30, and 34. I relied on Dr. Michael Nikolaou’s opinions and explanations related to Pioneer Energy’s MAGS System.

a. Independent Claim 1

i. *Limitation [1pre]*

“A system comprising:”

301. To the extent the preamble is limiting, the MAGS-Polivka combination renders [1pre] obvious. For example, MAGS is a mobile power generation system that can generate electricity using flare gas (raw natural gas that is to be flared) at an oil and gas production facility. [EX1013, 2]. Polivka also discloses a bitcoin miner system. [EX1015, 1-10].

ii. *Limitation [1a]*

“a source of combustible gas produced from a facility selected from a group consisting of a hydrocarbon production, storage, or processing facility;”

302. See Dr. Nikolaou’s declaration on Limitation [1a].

iii. *Limitation [1b]*

“a generator connected to the source of combustible gas to receive a continuous flow of combustible gas to power the generator; and”

303. See Dr. Nikolaou’s declaration on Limitation [1b].

iv. Limitation [1c]

“blockchain mining devices connected to the generator; in which:”

304. As discussed above, in the MAGS-Polivka combination, the combined device would have (1) the MAGS mobile power generation system; and (2) the Polivka mobile bitcoin miner, wherein the bitcoin mining devices (e.g., spondooliestech SP31 OR SP35 servers) are connected to and powered by the MAGS mobile power generation system.

305. For these reasons, and for the reasons provided by Dr. Nikolaou, I believe a POSITA would have understood that the MAGS-Polivka combination discloses this limitation.

v. Limitation [1c_i]

“the blockchain mining devices each have a mining processor and are connected to a network interface;”

306. As explained in the Bitcointalk forum post, the Polivka miner can carry various miners including Spondoolies-Tech SP31 and Bitmain Antminer S19. [EX1015, 17]. The Bitcointalk forum post explains that bitcoin mining requires access to Internet. [EX1015, 13]. A POSITA would have found it obvious that the blockchain mining devices (e.g., Spondoolies-Tech SP31) each have a mining processor and are connected to a network interface (e.g., a modem or a router). MAGS also includes a network interface in the form of a wireless router. [EX1014, FIG. 18, [0273]].

307. For these reasons, I believe a POSITA would have found this limitation to be obvious.

vi. Limitation [1c_ii]

“the network interface is connected to receive and transmit data through the internet to a network that stores or has access to a blockchain database;”

308. As explained in the Bitcointalk forum post, the Polivka miner can carry various miners including Spondoolies-Tech SP31 and Bitmain Antminer S19. [EX1015, 17]. The Bitcointalk forum post explains that bitcoin mining requires access to Internet. [EX1015, 13].

309. A POSITA would have understood that to mine bitcoin, the bitcoin miner needs to receive and transmit data through the internet to a network that stores or has access to a blockchain database. For example, Kheterpal explains that the Bitcoin protocol defines a system in which the creation and distribution of the bitcoin cryptocurrency is governed by consensus among a peer-to-peer network. [EX1010, [0004]]. The network maintains a public ledger in which new transactions are verified and recorded by members of the network via cryptography. *Id.* The operations of verifying and recording transactions of cryptocurrencies such as transactions in the bitcoin cryptocurrency are sometimes referred to as mining, because completion of each mining operation typically rewards the miner with newly created cryptocurrency (e.g., bitcoins). *Id.* Verified transactions and newly created bitcoins are recorded in the public ledger. *Id.* The public ledger serves as an official history of transactions. *Id.* The amount of cryptocurrency owned by any entity may be determined from the public ledger. *Id.*

310. Thus, a POSITA would have found it obvious that Polivka’s network interface is connected to receive and transmit data through the internet to a network that stores or has access to a blockchain database.

311. For these reasons, I believe a POSITA would have found this limitation to be obvious.

vii. Limitation [1c_iii]

“the mining processors are connected to the network interface and adapted to mine transactions associated with the blockchain database and to communicate with the blockchain database;”

312. As explained in the Bitcointalk forum post, the Polivka miner can carry various miners including Spondoolies-Tech SP31 and Bitmain Antminer S19. [EX1015, 17]. The Bitcointalk forum post explains that bitcoin mining requires access to Internet. [EX1015, 13].

313. A POSITA would have understood that to mine bitcoin, the mining processors need to be connected to the network interface and adapted to mine transactions associated with the blockchain database and to communicate with the blockchain database. For example, Kheterpal explains that the Bitcoin protocol defines a system in which the creation and distribution of the bitcoin cryptocurrency is governed by consensus among a peer-to-peer network. [EX1010, [0004]]. The network maintains a public ledger in which new transactions are verified and recorded by members of the network via cryptography. *Id.* The operations of verifying and recording transactions of cryptocurrencies such as transactions in the bitcoin cryptocurrency are sometimes referred to as mining, because completion of each mining operation typically rewards the miner with newly created cryptocurrency (e.g., bitcoins). *Id.* Verified transactions and newly created bitcoins are recorded in the public ledger. *Id.* The public ledger serves as an official history of transactions. *Id.* The amount of cryptocurrency owned by any entity may be determined from the public ledger. *Id.*

314. Thus, a POSITA would have found it obvious that Polivka’s mining processors (e.g., spondooliestech SP31 servers) are connected to the network interface and adapted to mine transactions associated with the blockchain database and to communicate with the blockchain database.

315. For these reasons, I believe a POSITA would have found this limitation to be obvious.

viii. Limitation [1c_iv]

“the network is a peer-to-peer network;”

316. A POSITA would have understood that bitcoin mining is conducted on a peer-to-peer network, because the Bitcoin protocol defines a system in which the creation and distribution of the bitcoin cryptocurrency is governed by consensus among a peer-to-peer network. [EX1010, [0004]].

317. Thus, a POSITA would have found it obvious that the network is a peer-to-peer network.

318. For these reasons, I believe a POSITA would have found this limitation to be obvious.

ix. Limitation [1c_v]

“the blockchain database is a distributed database stored on plural nodes in the peer-to-peer network; and”

319. A POSITA would have understood that in a bitcoin network, the blockchain database is a distributed database stored on plural nodes in the peer-to-peer network. For example, Kheterpal explains that the Bitcoin protocol defines a system in which the creation and distribution of the bitcoin cryptocurrency is governed by consensus among a peer-to-peer network. [EX1010, [0004]]. The network maintains a public ledger in which new transactions are verified and recorded by members of the network via cryptography. *Id.* The operations of verifying and recording transactions of cryptocurrencies such as transactions in the bitcoin cryptocurrency are sometimes referred to as mining, because completion of each mining operation typically rewards the miner with newly created cryptocurrency (e.g., bitcoins). *Id.* Verified transactions and newly created bitcoins are recorded in the public ledger. *Id.* The public ledger serves as an official history of

transactions. *Id.* The amount of cryptocurrency owned by any entity may be determined from the public ledger. *Id.*

320. Thus, a POSITA would have found it obvious that the blockchain database is a distributed database stored on plural nodes in the peer-to-peer network.

321. For these reasons, I believe a POSITA would have found this limitation to be obvious.

x. *Limitation [1c_vii]*

“the blockchain database stores transactional information for a digital currency.”

322. A POSITA would have understood that in a bitcoin network, the blockchain database stores transactional information for a digital currency. For example, Kheterpal explains that the Bitcoin protocol defines a system in which the creation and distribution of the bitcoin cryptocurrency is governed by consensus among a peer-to-peer network. [EX1010, [0004]]. The network maintains a public ledger in which new transactions are verified and recorded by members of the network via cryptography. *Id.* The operations of verifying and recording transactions of cryptocurrencies such as transactions in the bitcoin cryptocurrency are sometimes referred to as mining, because completion of each mining operation typically rewards the miner with newly created cryptocurrency (e.g., bitcoins). *Id.* Verified transactions and newly created bitcoins are recorded in the public ledger. *Id.* The public ledger serves as an official history of transactions. *Id.* The amount of cryptocurrency owned by any entity may be determined from the public ledger. *Id.*

323. Thus, a POSITA would have found it obvious that the blockchain database stores transactional information for a digital currency.

324. For these reasons, I believe a POSITA would have found this limitation to be obvious.

b. Dependent Claim 2

“The system of claim 1 isolated from a sales gas line and an external electrical power grid.”

325. See Dr. Nikolaou’s declaration on Limitation [2].

c. Dependent Claim 3

“The system of claim 1 in which: the source of combustible gas and the facility comprise a remote well selected from a group consisting of a remote oil or gas well; and the remote well is connected to produce the continuous flow of combustible gas to power the generator.”

326. See Dr. Nikolaou’s declaration on Limitation [3].

d. Dependent Claim 4

“The system of claim 3 further comprising a combustion engine connected to the source of combustible gas and connected to drive the generator.”

327. See Dr. Nikolaou’s declaration on Limitation [4].

e. Dependent Claim 8

“The system of claim 1 in which the generator and blockchain mining devices are located adjacent to the facility.”

328. A POSITA would understand that the ’372 patent discloses that the generator and blockchain mining device may be located adjacent to the remote oil well, for example within one hundred meters. [The ’372 patent, 9:17-19].

329. As discussed above, in the MAGS-Polivka combination, the combined device would have (1) the MAGS mobile power generation system; and (2) the Polivka mobile bitcoin miner, wherein the bitcoin mining devices (e.g., spondooliestech SP31 servers) are connected to and powered by the MAGS mobile power generation system.

330. Both the MAGS system and the Polivka system are containerized to confer better mobility. [EX1014, [0162], FIG. 4]; [EX1015, 1-10]. Thus, it is easy to combine the two by simply combining two containerized mobile systems. Thus, since the combined device is mobile, in order to save infrastructure costs and to avoid transporting the flare gas over a long distance, a POSITA

would have found it obvious that the generator and blockchain mining devices are located adjacent to the facility (e.g., within one hundred meters).

331. For these reasons, I believe a POSITA would have understood that the MAGS-Polivka combination discloses this limitation.

f. Dependent Claim 16

“The system of claim 1 in which a controller is connected to operate a cooling system to maintain the blockchain mining devices within a predetermined operating range of temperature.”

332. As shown in the below figure, the Polivka miner contains a cooling fan, multiple bitcoin miners on a rack, and a power distribution box on the left side.



Bitcointalk forum post, EX1015, 31

333. As shown in the below figure, the Polivka miner contains a power distribution box that controls the power distribution to various components. [EX1015, 8].

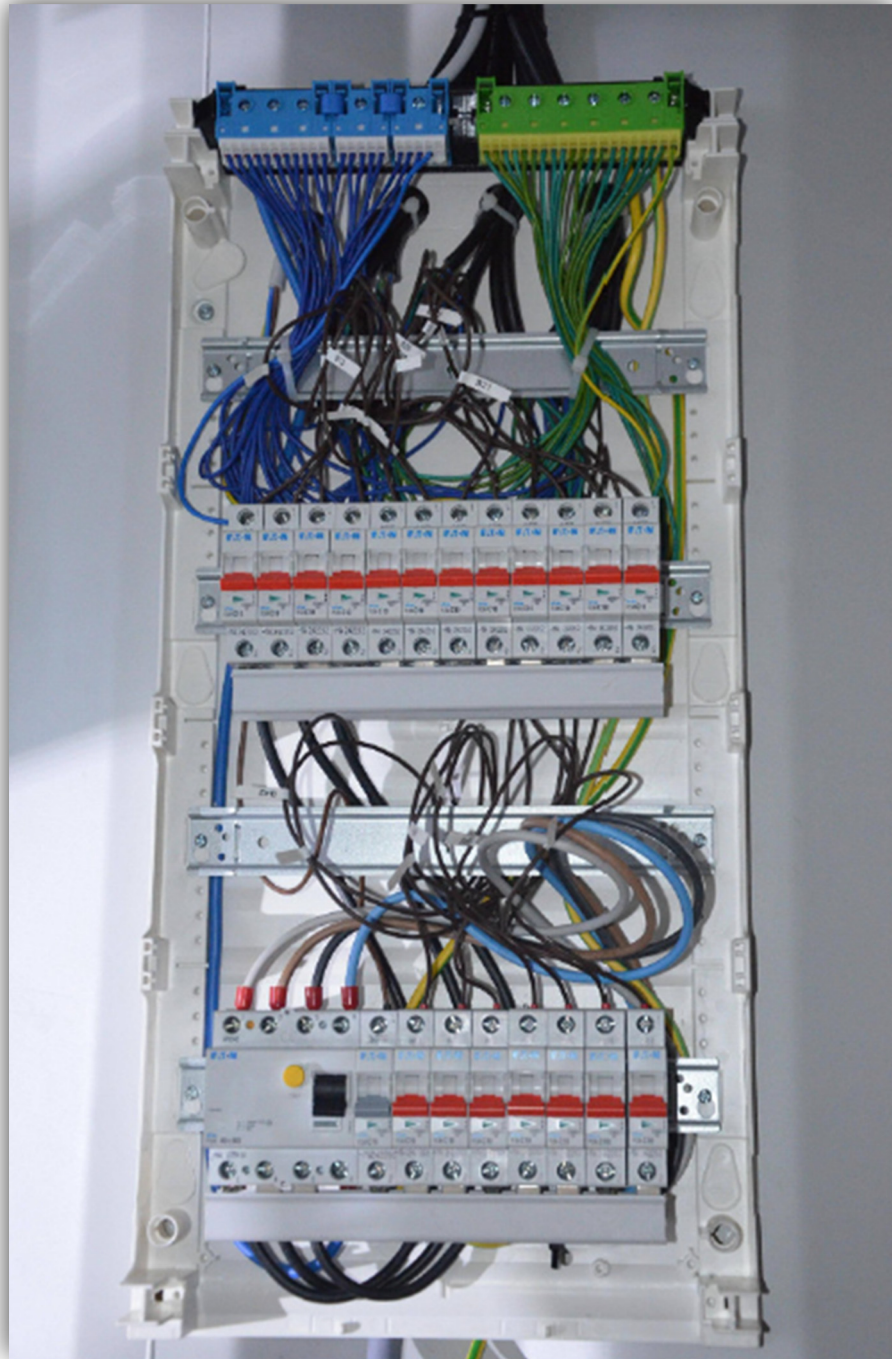

Bitcointalk forum post, EX1015, 8

334. Thus, a POSITA would have found it obvious that a controller (power distribution box) is connected to operate a cooling system (fans) to maintain the blockchain mining devices within a predetermined operating range of temperature.

335. For these reasons, I believe a POSITA would have found this limitation to be obvious.

g. Dependent Claim 17

“The system of claim 1 in which the blockchain mining devices are housed in a portable enclosure that is structured to one or more of form a skid or be mounted on a trailer.”

336. Both the MAGS system and the Polivka system are containerized to confer better mobility. [EX1014, [0162], FIG. 4]; [EX1015, 1-10]. As shown in the Bitcointalk forum post, the Polivka miner is adapted from a standard intermodal shipping container, and can be easily transported to remote well sites. [EX1015, 1-10]; [EX1019, 0:00:08]. For example, the Bitcointalk forum post explains that “the container can be loaded and unloaded without crane using the pictured pillars and an air-suspended truck only. (Almost all of the trucks in Europe have air suspension).” [EX1015, 10].



Bitcointalk forum post, EX1015, 1

337. A related video also shows that the Polivka system is mounted on a trailer. [EX1019, 0:00:08].

338. Thus, in the combined device, the blockchain mining devices are housed in a portable enclosure that is structured to one or more of form a skid or be mounted on a trailer.

339. For these reasons, I believe a POSITA would have understood that the combined device discloses this limitation.

h. Dependent Claim 18

“The system of claim 17 in which the portable enclosure comprises a generator driven by an engine, which is connected to the source of combustible gas.”

340. Both the MAGS system and the Polivka system are containerized to confer better mobility. [EX1014, [0162], FIG. 4]; [EX1015, 1-10]. Thus, it is easy to combine the two by simply

combining two containerized mobile systems into one container. A POSITA would have been motivated to do so because it will further save transportation costs.

341. Per Dr. Nikolaou's Declaration, the MAGS system uses methane to run a generator to replace the diesel generators powering the oil drilling rig. [EX1013, 3]. As shown in FIG. 8 of Young, the MAGS system comprises a combustion engine connected to drive the generator. [EX1014, [0323]].

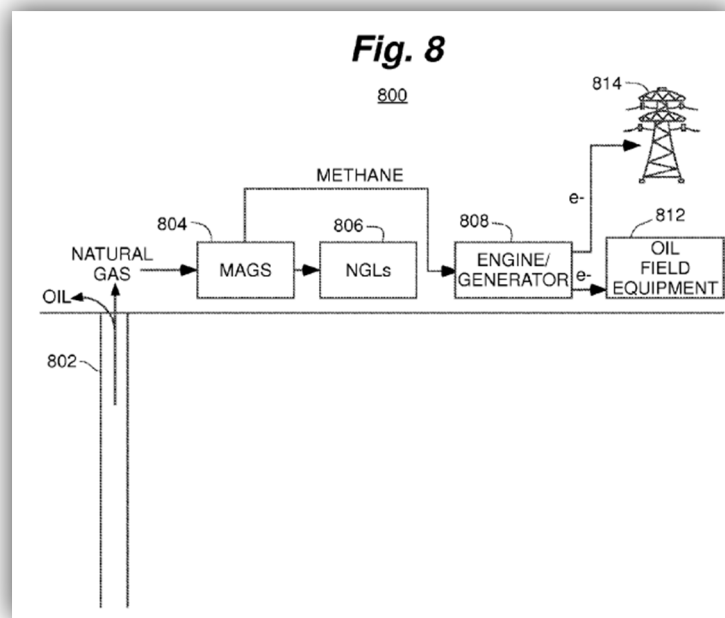

Young, EX1014, FIG. 8

342. Thus, a POSITA would have found it obvious that the portable enclosure (container) comprises a generator driven by an engine, which is connected to the source of combustible gas.

343. For these reasons, I believe a POSITA would have understood that the combined device discloses this limitation.

i. Dependent Claim 19

“The system of any claim 18 in which the engine comprises a turbine.”

344. See Dr. Nikolaou’s declaration on Limitation [19].

j. Dependent Claim 20

“The system of claim 17 in which the portable enclosure comprises an intermodal transport container.”

345. Both the MAGS system and the Polivka system are containerized to confer better mobility. [EX1014, [0162], FIG. 4]; [EX1015, 1-10]. The Bitcointalk forum post shows that the Polivka miner is adapted from a standard intermodal shipping container, and can be easily transported to remote well sites. [EX1015, 1-10]; [EX1019, 0:00:08]. For example, the Bitcointalk forum post explains that “the container can be loaded and unloaded without crane using the pictured pillars and an air-suspended truck only. (Almost all of the trucks in Europe have air suspension).” [EX1015, 10].



Bitcointalk forum post, EX1015, 1

346. A related video also shows that the Polivka system is mounted on a trailer. [EX1019, 0:00:08].

347. Thus, a POSITA would have found it obvious that the portable enclosure comprises an intermodal transport container.

k. Dependent Claim 21

“The system of claim 17 in which the portable enclosure has the form of a box with walls, a top, and a base, with one or more access doors formed in the walls.”

348. Both the MAGS system and the Polivka system are containerized to confer better mobility. [EX1014, [0162], FIG. 4]; [EX1015, 1-10]. The Bitcointalk forum post shows that the Polivka miner is adapted from a standard intermodal shipping container, and can be easily transported to remote well sites. [EX1015, 1-10]; [EX1019, 0:00:08]. For example, the Bitcointalk forum post explains that “the container can be loaded and unloaded without crane using the pictured pillars and an air-suspended truck only. (Almost all of the trucks in Europe have air suspension).” [EX1015, 10].



Bitcointalk forum post, EX1015, 1

349. As shown in a related video, the portable enclosure has the form of a box with walls, a top, and a base, with one or more access doors formed in the walls.



Polivka Video, EX1019, 0:00:08

350. For these reasons, I believe a POSITA would have understood that the combined device discloses this limitation.

i. Dependent Claim 22

The system of claim 1 further comprising a combustible gas disposal device, at the facility, the combustible gas disposal device being connected to receive combustible gas from the source of combustible gas.

351. See Dr. Nikolaou's declaration on Limitation [22].

m. Dependent Claim 23

“The system of claim 22 further comprising a valve connected upstream of the generator to receive the continuous flow of gas from the source of combustible gas, and selectively supply the continuous flow of gas to the generator, the combustible gas disposal device, or both the generator and the combustible gas disposal device, to selectively divert the continuous flow of gas to the combustible gas disposal device, the generator, or both the generator and the combustible gas disposal device, respectively.”

352. See Dr. Nikolaou’s declaration on Limitation [23].

n. Independent Claim 24

i. *Limitation [24pre]*

“A method comprising:”

353. To the extent the preamble is limiting, the MAGS-Polivka combination renders [24pre] obvious. For example, MAGS provides a method to generate electricity using flare gas (raw natural gas that is to be flared) at an oil and gas production facility. [EX1013, 2].

ii. *Limitation [24a]*

“producing electricity using a generator and a source of combustible gas produced at a facility selected from the group consisting of a hydrocarbon production well, storage, or processing facility, and”

354. See Dr. Nikolaou’s declaration on Limitation [24a].

iii. *Limitation [24b]*

“operating blockchain mining devices located at the facility, respectively, using the electricity, in which:”

355. As discussed above, in the MAGS-Polivka combination, the combined device would have (1) the MAGS mobile power generation system; and (2) the Polivka mobile bitcoin miner, wherein the bitcoin mining devices (e.g., spondooliestech SP31 servers) are connected to and powered by the MAGS mobile power generation system.

356. For these reasons, I believe a POSITA would have understood that the combined device discloses this limitation.

iv. *Limitation [24c]*

“the generator is connected to the source of combustible gas, in which the facility is connected to produce a continuous flow of combustible gas to power the generator;”

357. See Dr. Nikolaou’s declaration on Limitation [24c].

v. *Limitation [24d_i]*

“the blockchain mining devices each have a mining processor and are connected to a network interface;”

358. See discussion above in Ground 4 regarding [1c_i].

vi. Limitation [24d_ii]

“the network interface is connected to receive and transmit data through the internet to a network that stores or has access to a blockchain database;”

359. See discussion above in Ground 4 regarding [1c_ii].

vii. Limitation [24d_iii]

“the mining processors are connected to the network interface and adapted to mine transactions associated with the blockchain database and to communicate with the blockchain database;”

360. See discussion above in Ground 4 regarding [1c_iii].

viii. Limitation [24d_iv]

“the network is a peer-to-peer network;”

361. See discussion above in Ground 4 regarding [1c_iv].

ix. Limitation [24d_v]

“the blockchain database is a distributed database stored on plural nodes in the peer-to-peer network; and”

362. See discussion above in Ground 4 regarding [1c_v].

x. Limitation [24d_vi]

“the blockchain database stores transactional information for a digital currency.”

363. See discussion above in Ground 4 regarding [1c_vi].

o. Dependent Claim 25

“The method of claim 24 further comprising, prior to using the source of combustible gas: one or both disconnecting or diverting the source of combustible gas from a combustible gas disposal device at the facility; and connecting the source of combustible gas to operate the blockchain mining devices.”

364. See Dr. Nikolaou’s declaration on Limitation [25].

p. Dependent Claim 26

“The method of claim 25 in which the combustible gas disposal device comprises one or more of a flare, a vent to the atmosphere, an incinerator, or a burner.”

365. See Dr. Nikolaou’s declaration on Limitation [26].

q. Dependent Claim 27

“The method of claim 24 further comprising: connecting the source of combustible gas to operate the blockchain mining devices; and diverting gas from a combustible gas disposal device to operate the blockchain mining devices.”

366. See Dr. Nikolaou’s declaration on Limitation [27].

r. Dependent Claim 28

“The method of claim 24 in which the facility is selected from a group consisting of an oil or gas well that is isolated from a sales gas line and an external electrical power grid.”

367. See Dr. Nikolaou’s declaration on Limitation [28].

s. Dependent Claim 29

“The method of claim 24 in which the source of combustible gas is a remote well selected from a group consisting of a remote oil or gas well.”

368. See Dr. Nikolaou’s declaration on Limitation [29].

t. Dependent Claim 30

The method of claim 24 in which producing further comprises supplying combustible gas to a combustion engine that is connected to drive the generator.

369. See Dr. Nikolaou’s declaration on Limitation [30].

u. Dependent Claim 34

“The method of claim 29 further comprising operating the blockchain mining devices to: mine transactions with the blockchain mining devices; and communicate wirelessly through the internet to communicate with a blockchain database.”

370. As discussed above regarding [24d_iii], the mining processors are connected to the network interface and adapted to mine transactions associated with the blockchain database and to communicate with the blockchain database. A POSITA would have found it obvious that the

network interface connection is a wireless connection. For example, Kheterpal discloses that “[n]odes 10 of network 100 may be coupled via any desired underlying communications technology such as wired or wireless network technologies.” [EX1010, [0030]]. Thus, using a wireless network connection is an obvious design choice.

371. For these reasons, I believe a POSITA would have found this limitation to be obvious.

XVII. ANALYSIS OF PIONEER ENERGY’S MAGS SYSTEM, THE POLIVKA MINER, AND BELADY-989 (GROUND 5)

372. For the reasons articulated in detail below, and based on my review of the ’372 patent, the file history, the prior art cited here, Dr. Michael Nikolaou’s declaration, and my years of experience in the bitcoin mining industry, a POSITA would have readily understood that claims 1-4, 8, 10-12, 15-30, 34-37, and 40 are obvious over the combination of Pioneer Energy’s MAGS System, the Polivka miner, and Belady-989, in view of Szmigielski and Kheterpal.

A. It Would Have Been Obvious to a POSITA to Combine Pioneer Energy’s MAGS System, the Polivka Miner, and Belady-989 in view of Szmigielski and Kheterpal.

373. A POSITA would have found it obvious to combine the MAGS mobile generation system, the Polivka mobile miner, wherein the bitcoin mining devices (e.g., spondooliestch SP31 servers) are connected to and powered by the MAGS system; and Belady-989’s gas supply shock absorber.

374. As discussed above, the MAGS system generates free excess electricity and Smigielski discloses that one of the biggest costs for Bitcoin miners is the cost of electricity and access to cheap power is desired. [EX1009, 90].

375. Thus, a POSITA would have found it obvious to couple the Polivka mobile bitcoin miner with the MAGS system to utilize the free excess electricity.

376. Both the MAGS system and the Polivka system are containerized to confer better mobility. [EX1014, [0162], FIG. 4]; [EX1015, 1-10]. Thus, it is easy to combine the two by simply combining two containerized mobile systems into one. A POSITA would have had a reasonable expectation of success in the combination at least because “the first MAGS field unit was tested in the spring of 2014 and units were sent to North Dakota later that fall.” [EX1013, 3].

377. In the MAGS-Polivka combination, the combined device would have (1) the MAGS mobile power generation system; and (2) the Polivka mobile bitcoin miner, wherein the bitcoin mining devices (e.g., spondooliestech SP31 servers) are connected to and powered by the MAGS mobile power generation system.

378. Belady-989 describes a gas supply shock absorber (containing a gas storage) that is used to improve a data center system powered by a natural gas generator. [EX1011, Abstract]. If the shock absorber has sufficient gas, a co-located data center utilizes such gas for increased electrical power generation during increased processing activity, which can be requested or generated. [EX1011, Abstract]. Conversely, if the shock absorber has insufficient gas, and a negative pressure spike occurs, the data center throttles down or offloads processing. [EX1011, Abstract].

379. A POSITA would have understood that the flow of raw natural gas from the oil and gas facility may fluctuate and would have been motivated to further improve the MAGS-Polivka combination by employing Belady-989’s gas supply shock absorber because doing so will improve the energy usage efficiency. Indeed, Belady-989 discloses data centers often consume large quantities of electrical power, and should be located in areas where natural resources (e.g., flare gas), from which electrical power can be derived, are abundant and can be obtained inexpensively. [EX1011, [0004]]. Szmigielski also discloses that “[i]ndustrial miners face almost the same issues

as data centers: access to relatively cheap power, good network access...” [EX1009, 103]. Thus, a POSITA would have been motivated to combine MAGS, Polivka and Belady-989, to use Belady-989’s gas supply shock absorber to improve energy usage efficiency.

380. In the MAGS-Polivka-Belady-989 combination, the combined device would have (1) the MAGS mobile power generation system; (2) the Polivka mobile bitcoin miner, wherein the bitcoin mining devices (e.g., spondooliestech SP31 servers) are connected to and powered by the MAGS system; and (3) Belady-989’s gas supply shock absorber.

B. The Combination of Pioneer Energy’s MAGS System, the Polivka Miner, and Belady-989 Renders Claims 1-4, 8, 10-12, 15-30, 34-37, and 40 Obvious.

381. As I explain below, the combination of Pioneer Energy’s MAGS System, the Polivka miner, and Belady-989 renders obvious all limitations of claims 1-4, 8, 10-12, 15-30, 34-37, and 40. As stated above, I relied on Dr. Michael Nikolaou’s opinions and explanations related to Pioneer Energy’s MAGS system and Belady-989 for the purposes of this Declaration.

a. Independent Claim 1

i. *Limitation [1pre]*

“A system comprising:”

382. See discussion above in Ground 4.

ii. *Limitation [1a]*

“a source of combustible gas produced from a facility selected from a group consisting of a hydrocarbon production, storage, or processing facility;”

383. See Dr. Nikolaou’s declaration on Limitation [1a].

iii. *Limitation [1b]*

“a generator connected to the source of combustible gas to receive a continuous flow of combustible gas to power the generator; and”

384. See Dr. Nikolaou’s declaration on Limitation [1b].

iv. *Limitation [1c]*

“blockchain mining devices connected to the generator; in which:”

385. See discussion above in Ground 4.

v. Limitation [1c_i]

“the blockchain mining devices each have a mining processor and are connected to a network interface;”

386. See discussion above in Ground 4.

387. Further, Belady-989 discloses that “the data center 190 can comprise a communication connection 191 to a network 199.” [EX1011, [0029]].

vi. Limitation [1c_ii]

“the network interface is connected to receive and transmit data through the internet to a network that stores or has access to a blockchain database;”

388. See discussion above in Ground 4.

vii. Limitation [1c_iii]

“the mining processors are connected to the network interface and adapted to mine transactions associated with the blockchain database and to communicate with the blockchain database;”

389. See discussion above in Ground 4.

viii. Limitation [1c_iv]

“the network is a peer-to-peer network;”

390. See discussion above in Ground 4.

ix. Limitation [1c_v]

“the blockchain database is a distributed database stored on plural nodes in the peer-to-peer network; and”

391. See discussion above in Ground 4.

x. Limitation [1c_vi]

“the blockchain database stores transactional information for a digital currency.”

392. See discussion above in Ground 4.

b. Dependent Claim 2

“The system of claim 1 isolated from a sales gas line and an external electrical power grid.”

393. See Dr. Nikolaou’s declaration in Ground 5 on Limitation [2].

c. Dependent Claim 3

“The system of claim 1 in which: the source of combustible gas and the facility comprise a remote well selected from a group consisting of a remote oil or gas well; and the remote well is connected to produce the continuous flow of combustible gas to power the generator.”

394. See Dr. Nikolaou’s declaration in Ground 5 on Limitation [3].

d. Dependent Claim 4

“The system of claim 3 further comprising a combustion engine connected to the source of combustible gas and connected to drive the generator.”

395. See Dr. Nikolaou’s Declaration in Ground 5 on Limitation [4].

e. Dependent Claim 8

“The system of claim 1 in which the generator and blockchain mining devices are located adjacent to the facility.”

396. See discussion above in Ground 4 on Limitation [4].

f. Dependent Claim 10

“The system of claim 1 in which the system is configured to modulate a power load level exerted by the blockchain mining devices on the generator, by increasing or decreasing the mining activity of the mining processor.”

397. As discussed above, in the MAGS-Polivka-Belady-989 combination, the combined device would have (1) the MAGS mobile power generation system; (2) the Polivka mobile bitcoin miner, wherein the bitcoin mining devices (e.g., spondooliestech SP31 servers) are connected to and powered by the MAGS system; and (3) Belady-989’s gas supply shock absorber.

398. Per Dr. Nikolaou’s Declaration, Belady-989 describes a gas supply shock absorber (containing a gas storage) that is used to improve a data center system powered by a natural gas

generator. [EX1011, Abstract]. If the shock absorber has sufficient gas, a co-located data center utilizes such gas for increased electrical power generation during increased processing activity, which can be requested or generated. [EX1011, Abstract]. Conversely, if the shock absorber has insufficient gas, and a negative pressure spike occurs, the data center throttles down or offloads processing. [EX1011, Abstract]. A POSITA would have found it obvious to control power load level of the Polivka miner (e.g., by turning off a certain number of mining processors) using Belady-989's method based on input from Belady-989's tank pressure sensor to increase energy usage efficiency.

399. Thus, in the MAGS-Polivka-Belady-989 combination, the system is configured to modulate a power load level exerted by the blockchain mining devices on the generator, by increasing or decreasing the mining activity of the mining processor.

400. For these reasons, and for the reasons provided by Dr. Nikolaou, I believe a POSITA would have understood that the combined device discloses this limitation.

g. Dependent Claim 11

“The system of claim 10 in which the system is configured to modulate the power load level by selecting one or more actions from a group of actions consisting of increasing or decreasing a maximum number of mining processors that are engaged in mining transactions.”

401. As discussed above with regard to Limitation [10], a POSITA would have found it obvious to control power load level of the Polivka miner (e.g., by turning off a certain number of mining processors) using Belady-989's method based on input from Belady-989's tank pressure sensor to increase energy usage efficiency. For example, a POSITA would have found it obvious to adjust the mining activity of the mining processors by increasing or decreasing a maximum number of mining processors that are engaged in mining transactions.

402. See Dr. Nikolaou's declaration on Limitation [11].

h. Dependent Claim 12

“The system of claim 10 in which the system is configured to modulate the power load level in response to variations in a production rate of combustible gas from the hydrocarbon production well, storage, or processing facility.”

403. As discussed above with regard to Limitation [10.0], a POSITA would have found it obvious to control power load level of the Polivka miner (e.g., by turning off a certain number of mining processors) using Belady-989’s method based on input from Belady-989’s tank pressure sensor to increase energy usage efficiency.

404. Per Dr. Nikolaou’s Declaration, Belady-989 discloses that its gas supply shock absorber comprises pressure sensing valves and pressure regulating valves, which can detect positive pressure spikes in the gas supply and enable such overly pressurized gas to charge the gas storage, and which can also detect negative pressure spikes in the gas supply and, in response, make available the gas stored in the gas storage to compensate for such negative pressure spikes. [EX1011, [0015]]. Belady-989 further discloses that if the gas storage has a sufficient quantity of gas stored therein, the data center can utilize such gas to provide increased electrical power during periods of increased processing activity and workload. [EX1011, [0015]]. Conversely, if the gas storage has an insufficient quantity of gas stored therein, and the gas supply experiences a negative pressure spike, the computing devices of the data center can be throttled down to consume less electrical power. [EX1011, [0015]]. A POSITA would have found it obvious that Belady-989’s gas pressure sensor regulates the power load level of the bitcoin miners (e.g., by turning off a certain number of mining processors) based on input from Belady-989’s tank pressure sensor in response to variations in a production rate of combustible gas.

405. For these reasons, and for the reasons provided by Dr. Nikolaou, I believe a POSITA would have understood that the combined device discloses this limitation.

i. Dependent Claim 15

“The system of claim 10 in which: a production rate of combustible gas from the hydrocarbon production well, storage, or processing facility varies between a daily minimum production rate and a daily maximum production rate; the controller is set to limit the power load level to above a power level producible by the generator when the production rate is at the daily minimum production rate; and a backup source, selected from a group consisting of fuel or electricity, is connected make up a shortfall in fuel or electricity, respectively, required to supply the blockchain mining devices with the power load level.”

406. As discussed above with regard to Limitation [10.0], a POSITA would have found it obvious to control power load level of the Polivka miner (e.g., by turning off a certain number of mining processors) using Belady-989’s method based on input from Belady-989’s tank pressure sensor to increase energy usage efficiency.

407. See Dr. Nikolaou’s declaration on Limitation [15].

j. Dependent Claim 16

“The system of claim 1 in which a controller is connected to operate a cooling system to maintain the blockchain mining devices within a predetermined operating range of temperature.”

408. See discussion above in Ground 4.

k. Dependent Claim 17

“The system of claim 1 in which the blockchain mining devices are housed in a portable enclosure that is structured to one or more of form a skid or be mounted on a trailer.”

409. See discussion above in Ground 4.

l. Dependent Claim 18

“The system of claim 17 in which the portable enclosure comprises a generator driven by an engine, which is connected to the source of combustible gas.”

410. See discussion above in Ground 4.

m. Dependent Claim 19

“The system of any claim 18 in which the engine comprises a turbine.”

411. See discussion above in Ground 4.

n. Dependent Claim 20

“The system of claim 17 in which the portable enclosure comprises an intermodal transport container.”

412. See discussion above in Ground 4.

o. Dependent Claim 21

“The system of claim 17 in which the portable enclosure has the form of a box with walls, a top, and a base, with one or more access doors formed in the walls.”

413. See discussion above in Ground 4.

p. Dependent Claim 22

“The system of claim 1 further comprising a combustible gas disposal device, at the facility, the combustible gas disposal device being connected to receive combustible gas from the source of combustible gas.”

414. See Dr. Nikolaou’s declaration in Ground 5 on Limitation [22].

q. Dependent Claim 23

“The system of claim 22 further comprising a valve connected upstream of the generator to receive the continuous flow of gas from the source of combustible gas, and selectively supply the continuous flow of gas to the generator, the combustible gas disposal device, or both the generator and the combustible gas disposal device, to selectively divert the continuous flow of gas to the combustible gas disposal device, the generator, or both the generator and the combustible gas disposal device, respectively.”

415. See Dr. Nikolaou’s declaration in Ground 5 on Limitation [23].

r. Independent Claim 24

i. Limitation [24pre]

“A method comprising:”

416. See discussion above in Ground 4.

ii. Limitation [24a]

“producing electricity using a generator and a source of combustible gas produced at a facility selected from the group consisting of a hydrocarbon production well, storage, or processing facility, and”

417. See Dr. Nikolaou’s declaration in Ground 5 on Limitation [24a].

iii. Limitation [24b]

“operating blockchain mining devices located at the facility, respectively, using the electricity, in which:”

418. See discussion above in Ground 4.

iv. Limitation [24c]

“the generator is connected to the source of combustible gas, in which the facility is connected to produce a continuous flow of combustible gas to power the generator;”

419. See discussion above in Ground 4.

v. Limitation [24d_i]

“the blockchain mining devices each have a mining processor and are connected to a network interface;”

420. See discussion above in Ground 4.

421. Further, Belady-989 discloses that “the data center 190 can comprise a communication connection 191 to a network 199.” [EX1011, [0029]].

vi. Limitation [24d_ii]

“the network interface is connected to receive and transmit data through the internet to a network that stores or has access to a blockchain database;”

422. See discussion above in Ground 4.

vii. Limitation [24d_iii]

“the mining processors are connected to the network interface and adapted to mine transactions associated with the blockchain database and to communicate with the blockchain database;”

423. See discussion above in Ground 4.

viii. Limitation [24d_iv]

“the network is a peer-to-peer network;”

424. See discussion above in Ground 4.

ix. Limitation [24d_v]

“the blockchain database is a distributed database stored on plural nodes in the peer-to-peer network; and”

425. See discussion above in Ground 4.

x. ***Limitation [24d_vj]***

“the blockchain database stores transactional information for a digital currency.”

426. See discussion above in Ground 4.

s. **Dependent Claim 25**

“The method of claim 24 further comprising, prior to using the source of combustible gas: one or both disconnecting or diverting the source of combustible gas from a combustible gas disposal device at the facility; and connecting the source of combustible gas to operate the blockchain mining devices.”

427. See discussion above in Ground 4.

t. **Dependent Claim 26**

“The method of claim 25 in which the combustible gas disposal device comprises one or more of a flare, a vent to the atmosphere, an incinerator, or a burner.”

428. See Dr. Nikolaou’s declaration in Ground 5 on Limitation [26].

u. **Dependent Claim 27**

“The method of claim 24 further comprising: connecting the source of combustible gas to operate the blockchain mining devices; and diverting gas from a combustible gas disposal device to operate the blockchain mining devices.”

429. See Dr. Nikolaou’s declaration in Ground 5 on Limitation [27].

v. **Dependent Claim 28**

“The method of claim 24 in which the facility is selected from a group consisting of an oil or gas well that is isolated from a sales gas line and an external electrical power grid.”

430. See Dr. Nikolaou’s declaration in Ground 5 on Limitation [28].

w. **Dependent Claim 29**

“The method of claim 24 in which the source of combustible gas is a remote well selected from a group consisting of a remote oil or gas well.”

431. See Dr. Nikolaou's declaration in Ground 5 on Limitation [29].

x. **Dependent Claim 30**

"The method of claim 24 in which producing further comprises supplying combustible gas to a combustion engine that is connected to drive the generator."

432. See discussion above in Ground 4.

y. **Dependent Claim 34**

"The method of claim 29 further comprising operating the blockchain mining devices to: mine transactions with the blockchain mining devices; and communicate wirelessly through the internet to communicate with a blockchain database."

433. See discussion above in Ground 4.

z. **Dependent Claim 35**

"The method of claim 34 further comprising modulating a power load level exerted by the blockchain mining devices on the generator, by selecting an action from a group of actions consisting of increasing or decreasing, a mining activity of the blockchain mining devices."

434. See discussion above regarding [10.0].

aa. **Dependent Claim 36**

"The method of claim 35 in which: modulating comprises modulating the power load level by increasing or decreasing a maximum number of mining processors that are engaged in mining transactions."

435. See discussion above regarding [11.0].

bb. **Dependent Claim 37**

"The method of claim 36 in which modulating comprises modulating the power load level in response to variations in a production rate of combustible gas from the hydrocarbon production well, storage, or processing facility."

436. See discussion above regarding [12.0].

cc. **Dependent Claim 40**

"The method of claim 35 in which: a production rate of combustible gas from the hydrocarbon production well, storage, or processing facility varies between a daily minimum production rate and a daily maximum production rate; modulating comprises limiting the power load level to above a power level produced by the generator when

the production rate is at the daily minimum production rate; and supplying from a backup source, which is selected from a group consisting of a backup fuel or electricity source a shortfall in fuel or electricity, respectively, required to supply the blockchain mining devices with the power load level.”

437. See discussion above regarding [15.0].

XVIII. ANALYSIS OF THE CLAIMS OF THE '372 PATENT

438. Based on my knowledge and experience and my reading of the claims and patent and review of Dr. Nikolaou’s Declaration (EX1003), I believe that all the claims are directed to the abstract idea of powering a cryptocurrency mine with gas from a hydrocarbon facility and do not recite anything more than conventional equipment operating conventionally.

439. As I explain below, the claims of the '372 patent are directed to the abstract idea of using flare gas to power a cryptomine. I relied on Dr. Nikolaou’s opinions and explanations related to hydrocarbon extraction/production and power generation for the purposes of this declaration.

440. For independent Claims 1 and 24, the recited limitations related to a blockchain mining device recite only generic computer elements known to the industry and are essential features to any blockchain mining device. And, as per Dr. Niolaou’s review, the recited limitations related to a source of combustible gas and a generator recite nothing more than generic industry used equipment and materials commonly found at hydrocarbon production, storage, or processing facilities. [EX1003]. Furthermore, Claims 1 and 24 recite nothing that changes or effects the way the underlying technology would normally operate.

441. As per Dr. Nikolaou’s declaration, Claims 2, 3, 7-9, and 27-29 recite little more than selecting particular, yet common, hydrocarbon facility for the location of a blockchain mine. [EX1003].

442. As per Dr. Nikolaou’s declaration, Claims 4-6, 19, and 30-33 recite little more than common iterations of conventional prime movers used with power generators. [EX1003].

443. Claims 10-15 and 35-41 recite only common system controls for operating a blockchain mining device and modulating it in response to power availability—a common issue for blockchain mining operations. Further, the limitations of Claims 15 and 40 wherein a backup source of power is integrated into the system recites common equipment that is commonly used for any sort of data processing to ensure regular production. Even laptops throttle performance when the battery is low and many facilities use backup power generation systems. Claims 14 and 39 recites nothing more than a conventional load bank used in a conventional manner.

444. Claim 16 recites the conventional practice using a cooling system to automatically regulate the temperature of computers performing large amounts of data processing. This is almost always a required element of any data center and not an inventive change to a blockchain mining device.

445. Claims 17, 20-21 recite the common practice of building datacenters or other computers withing portable enclosures and does recite any limitation to any blockchain mining specific requirements.

446. Claim 18 recites the common practice of integrating a standard generator within a portable enclosure in conjunction with other equipment.

447. As per Dr. Nikolaou's declaration, Claims 22-23, and 25-26 describe nothing more than the current industry practice of venting or flaring excess gas at a hydrocarbon facility or using splitting the gas between a venting or flaring device while supplying the rest to a power generator. [EX1003].

448. Claim 34 only recites the additional feature of using a conventional wireless internet connection which is common industry practice for any mobile or remote computing platform.

449. Ultimately, the patent claims of the '372 patent recite conventional equipment that operate in a conventional manner.

XIX. CONCLUSION

450. The findings and opinions set forth in this declaration are based on my work and examinations to date.

451. I may continue my examinations. I may also receive additional documentation and other factual evidence over the course of this PGR that will allow me to supplement and/or refine my opinions. I reserve the right to add to, alter, or delete my opinions and my declaration upon discovery of any additional information. I reserve the right to make such changes as may be deemed necessary.

452. In signing this declaration, I recognize that the declaration will be filed as evidence in an PGR before the PTAB. I also recognize that I may be subject to cross-examination in the case and that cross-examination will take place within the United States. If cross-examination is required of me, I will appear for cross-examination within the United States during the time allotted for cross- examination.

453. I hereby declare that all statements made herein of my own knowledge are true and that all statements made on information and belief are believed to be true; and further that these statements were made with the knowledge that willful false statements and the like are punishable by fine or imprisonment, or both, under Section 1001 of Title 18 of the United States Code.

Dated: 7/20/2023

A handwritten signature in black ink, consisting of several overlapping, stylized strokes that form a cursive-like shape.

Vernon Kasdorf

APPENDIX A

Curriculum Vitae

Vern Kasdorf
604-309-4569 Cellular

Employment Overview

KubeData Systems Inc. - February 2020 – present

Position Summary -

KubeData Systems Inc. provides senior, strategic IT consulting services to mining companies, IoT companies and large Enterprise organizations. KubeData provides software and hardware development services to various companies, with a focus on the IoT (Internet of Things) vertical. Another offering is Strategic IT review services for operational effectiveness, merger and acquisition activities or regulatory compliance.

Loop Insights Inc. - March 2019 – January 2020

Position Summary -

As the CIO at Loop Insights, I was responsible for all aspects of technology delivery. Loop Insights is an IoT startup in Vancouver, BC, providing retail analytics to brands, agencies and data partners to build personalized customer experiences and loyalty. The proprietary IoT technology derives real-time, actionable insights based on each individual item purchased. This deeper insight into retail purchasing operates independently of the existing legacy POS systems and can roll up insights across multiple store locations, across a whole brand or across a whole industry by region.

At Loop, I developed a cutting edge cloud analytics service, based on data from our proprietary, cellular-connected IoT devices. I also led the team that developed the hardware and firmware products necessary to collect the retail transactional data.

TELUS – January 2016 – March 2019

Position Summary -

Director, IoT Delivery & Support

The Director, IoT Delivery & Support is responsible to support two teams. The Delivery team is made up of a Solutions Architect and Project Managers that implement any complex IoT solutions that are sold by TELUS. The Delivery team also works closely with the Sales Specialists and technical resources through the solutions architect to ensure the design of the complex solutions are valid, supportable and capable of being implemented by the Delivery team.

The Support team is made up of an Operations Manager that supports a number of virtual teams that include a dedicated IoT level 1 Service Desk called the IoT Center of Excellence. This team of nine provides the first level response to IoT incidents, supports the sales team in presale activities like provisioning trial kits as well as supporting the client with post sales care with items such as billing issues and SIM orders. The Support team also relies on a shared second level network support team as well as a 3rd level support team in Wireless Network Operations. These virtual teams work together to provide end to end care and support for the IoT clients.

Designed and developed (in house development team) an IoT Platform for TELUS to manage all IoT clients, manage the onboarding of all new clients, automate deployment of complex networking products and provide self-serve sales to increase sales and profitability.

KubeData Systems Inc. – July 2013 – December 2015

Company -

KubeData Systems Inc. manufactured custom built, Hi-tech Mobile Structures. These include data centers, control rooms, and communication shelters. While the focus was primarily the mining and petroleum industries, the launch of a new product, the CryptoKube, addressed the demand for an Industrial cryptocurrency mining mobile data center and was also our first 100% free-cooled data center. Kubedata designed and built three generations of CryptoKube mining data centers, servicing the Canadian and US market. KubeData has completed projects for petroleum companies, mining companies, a submarine manufacturer and even the US Navy. KubeData also provides IT consulting for several large organizations headquartered in Vancouver.

Position Summary -

Owner and partner in KubeData Systems Inc. with a focus on product development, business development and IT strategic consulting.

Accomplishments:

- Designed three data center models, marketing to the mining, oil and gas and cryptocurrency industries
- Started selling two of the models into both the mining and cryptocurrency verticals
- Extensive experience in not only building industrial cryptocurrency mining data centers, but also mining Bitcoin
- Built other enclosures such as pump enclosures for mining, electrical enclosures for oil and gas and control system enclosures to operate research submarines
- IT Strategic Consulting to Goldcorp (the world's largest gold miner), RECBC (Real Estate Council of British Columbia) and Pavco (BC Place and the Vancouver Convention Center)

Bulldog Containers – October 2012 - June 2013

Company -

Bulldog Containers. manufactured custom built, Hi-tech Mobile Structures. These include data centers, control rooms, and communication shelters. While the focus was primarily the mining and petroleum industries.

Position Summary -

Partner in Bulldog Containers with a focus on mobile data center product development.

Teck Resources Limited – August 2006 – September 2012

Company -

Teck Resources Limited employs over 14,000 staff, with ownership or interest in 13 mines and one smelter in Canada, Chile, USA and Peru. Teck is focused on copper, steelmaking coal, zinc and energy, and is also a significant producer of specialty metals such as germanium and indium. With sales of over 11 billion dollars in 2011, Teck was the largest company in British Columbia.

Position Summary -

Director, Global IS Infrastructure, is primarily responsible for IS Infrastructure Operations and project delivery across approximately 50 mine and office sites. This includes all common infrastructure such as physical access security, computing security, data center facilities and operations, Microsoft SQL, unified communications and global networks. The Director, IS Global Infrastructure was also responsible for Infrastructure Architecture and for a major projects support function to provide IT support for the

major capital projects (almost 20 billion in new and expanded mines). The major projects function provided heavy IT involvement in the pre-feasibility and feasibility stage of these types of projects which had never been done before.

Other responsibilities:

- Responsible for global data center operations
- Started the PMO and ran it for 2 years
- Developed the IT purchasing department and ran it for 4 years, saving \$8 million dollars in the best year
- Worked closely with the VP, Risk and Security while running the IS Security function (physical access security and logical security)
- Spearheaded the major projects support function
- Developed and ran the IT architecture group for 5 years
- Integrated two large acquisitions (Elk Valley Coal Corp. - \$15 Billion, and Aur Resources – 4 billion) into Teck common infrastructure

Accomplishments:

- Complete global standardization of server virtualization, storage systems, backup software, IP telephony (8500 handsets), monitoring systems, server patching systems, DMZs, firewalls, Microsoft SQL, video conferencing
- Primary global data center move from Vancouver to Calgary
- Several major data center consolidations as a result of large mergers
- Global backup and DR data center built and maintained actively
- Successful data center contract negotiations in both Canada and Chile
- All backups centralized to the Toronto DR datacenter (over 2 Pb of backup data)
- Achieved greater than 92% server virtualization globally
- Developed and rolled out a standard Cisco IP telephony system at every location
- Developed a standard MPLS network for all production sites and major offices globally
- Heavy involvement in SOX compliance management. Achieved zero significant deficiencies in 2011
- Completed the Emerging Leader Program, an internal program designed to groom hand selected individuals for senior leadership positions. A total of 64 people completed the course of the over 14,000 people at Teck Resources.

Barrick Gold Corporation (Placer Dome Inc.) – Oct 2005 – August 2006

Company -

Vancouver-based Placer Dome Inc. employed 13,000 people, primarily mining gold and copper at 16 mining operations in seven countries. In January of 2006, Barrick Gold Corp bought a controlling interest in Placer Dome, making Barrick the largest gold mining company in the world. The new company now employs over 20,000 people in 10 countries with 26 operating mines.

Position Summary -

Manager, IT Projects role included responsibility for all IT projects that had a global footprint including Active Directory rollout, SMS rollout, WAN upgrades, Datacentre upgrades, Livelink (document management) rollout, VOIP deployments, SAP rollout infrastructure preparation, and LAN upgrades. These projects spanned all locations on 4 continents. In addition to coordinating these projects, was tasked with building a formal PMO office. Was also responsible for vendor management and held the multi-million dollar central IT budget.

SPI Service Partners Inc. - (Self Employed) – Dec 2002 – Dec 2005

Company -

Service Partners provides IT consulting services to businesses in Vancouver and the Lower Mainland with a focus on IT infrastructure management, process development and project management. SPI also released a commercial software product called Processing Centre. This software is designed for large liquidation company warehouse operations to sort, label, manage and warehouse incoming shipments. This software was sold to clients in British Columbia, California and Washington State.

Enterprise Contracts

Placer Dome – Contracted by Placer Dome (1.8 Billion, 13,000 employees worldwide), a gold and copper mining company, to project manage the integration between handheld barcode scanning computers and SAP. These handheld computers are used in the warehouse to issue goods and perform inventory functions at the mine sites. The software was customized by Psion Teklogix to provide the integration with a four month old implementation of SAP.

Intrawest Corporation – Contracted by Intrawest (1.5 Billion, 22,000 employees worldwide) to project manage a data centre configuration management initiative.

Terasen Gas – Contracted by TELUS (\$7 Billion, 24,000 employees) to assist them with their IT outsourcing client Terasen Gas (\$1.8 Billion, 1400 employees). The contract included process development, contract analysis, increasing profitability, documentation project assistance and service level reporting cleanup.

MTF Discount Warehouse – MTF (8 locations and 2 warehouses) is a freight damaged liquidator with a contract to purchase most of the store returns and shelf pulls from the Costco warehouses in BC. They required a consulting firm to manage and architect their IT infrastructure. We assisted MTF in developing an IT strategy to network their locations, move to POS systems in their retail store locations and streamline their warehouse operations with a combination of custom software and a warehouse management system written and deployed by Service Partners.

Fluent Solutions - (dba Impact Creative Visual Communications) - Feb. 2000 –March 31, 2002

Company -

Impact Creative was a full service visual communications studio providing strategic design, branding and marketing solutions for 13 years. Services include graphic design, video production, commercial photography, multi-media design, website and Internet application development. Impact Creative was acquired on October 19, 2000 by Fluent Solutions of Novato, California.

Position Summary -

Technical Director of the Canadian operations of Fluent Solutions involved managing the IT resources of the company, providing leadership and architectural direction to the web application developers, and managing the rollout, operations and sales of web application solutions.

ISMBC (now TELUS) Aug. 1996 – Nov. 1999

Company -

ISMBC was an IT management and application development outsourcing company operating across Canada and the Pacific Rim. With 1600 employees and \$300 million in revenue, ISMBC was a company that was a major contender in the IT management sector.

Client List -

Below is a list of outsourced clients I managed over three years at ISMBC:

- Scott Paper – New Westminster to Quebec
- Finning – Client Acquisition
- ISMBC (internal client) – 1600 employees, 15+ locations

- Ainsworth Lumber – Data Center move and ongoing management
- BCTel (TELUS) – 7 different divisions of TELUS
- West Coast Energy – 17 million dollar Datacenter
- Versacold – Multi-location cold storage client

Education

Trinity Western University – BA, Business Administration (1992)