



US 20070105626A1

(19) **United States**  
 (12) **Patent Application Publication** (10) **Pub. No.: US 2007/0105626 A1**  
**Cho et al.** (43) **Pub. Date: May 10, 2007**

(54) **TOUCH SCREEN INPUTS FOR A VIDEO GAME SYSTEM**

**Related U.S. Application Data**

(75) Inventors: **Wing Cho**, Redmond, WA (US);  
**Darren Smith**, Bellevue, WA (US)

(60) Provisional application No. 60/709,447, filed on Aug. 19, 2005.

**Publication Classification**

Correspondence Address:  
**NIXON & VANDERHYTE, P.C.**  
901 NORTH GLEBE ROAD, 11TH FLOOR  
ARLINGTON, VA 22203 (US)

(51) **Int. Cl.**  
**A63F 13/00** (2006.01)  
(52) **U.S. Cl.** ..... **463/37**

(73) Assignees: **Nintendo Software Technology Corporation**, Redmond, WA (US); **Nintendo of America Inc.**, Redmond, WA (US)

**ABSTRACT**

Example systems and methods involve a video game system that has a touch sensitive display screen that can be used to supply inputs used in video game control. In one example system and method, a user or player draws movement patterns on the touch sensitive display screen. The drawn movement patterns are stored and a game object can be moved in accordance with a drawn movement pattern selected from the memory by the user.

(21) Appl. No.: **11/507,020**  
(22) Filed: **Aug. 21, 2006**

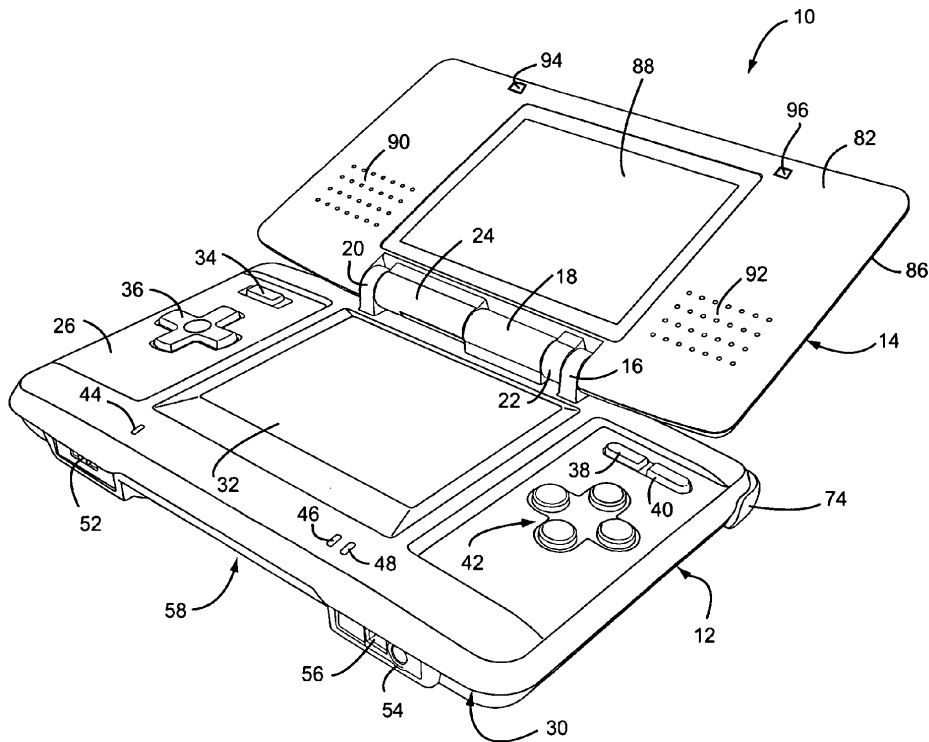

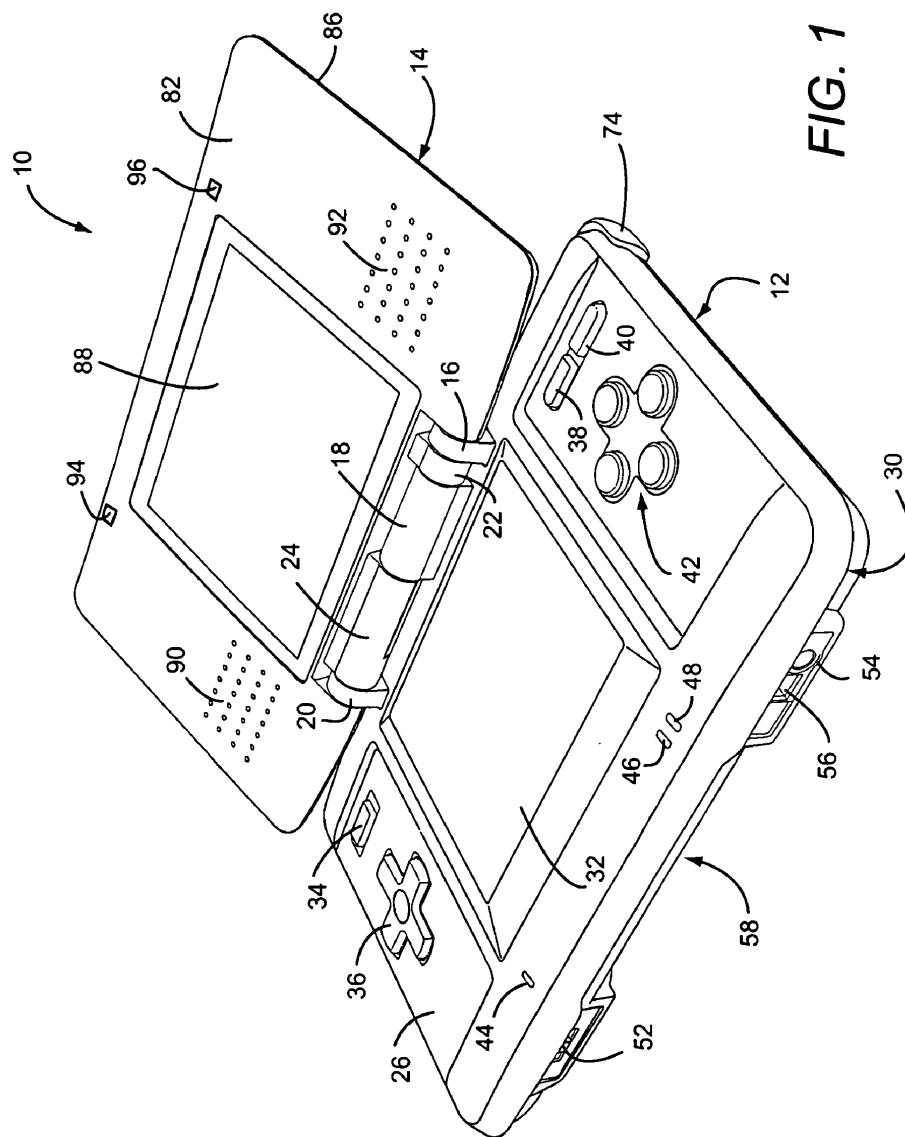

FIG. 1

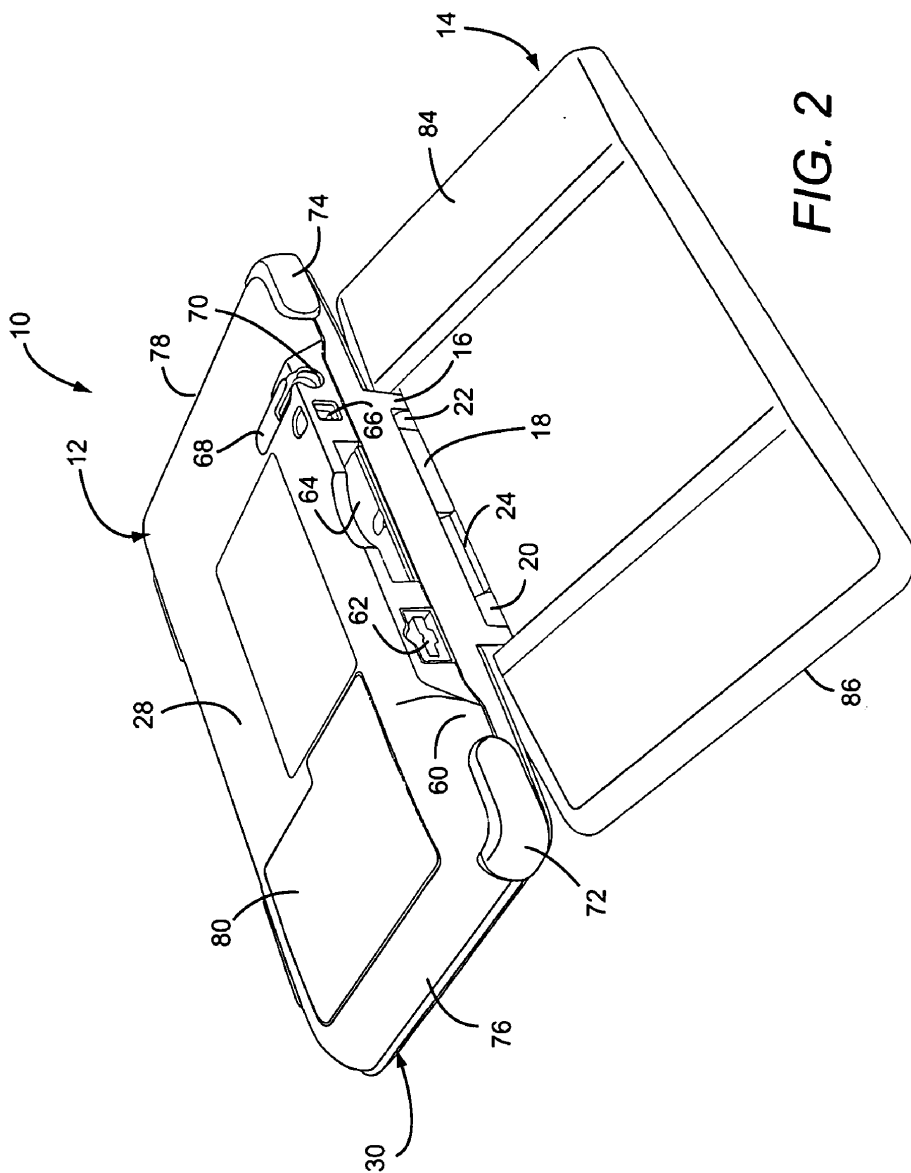

FIG. 2

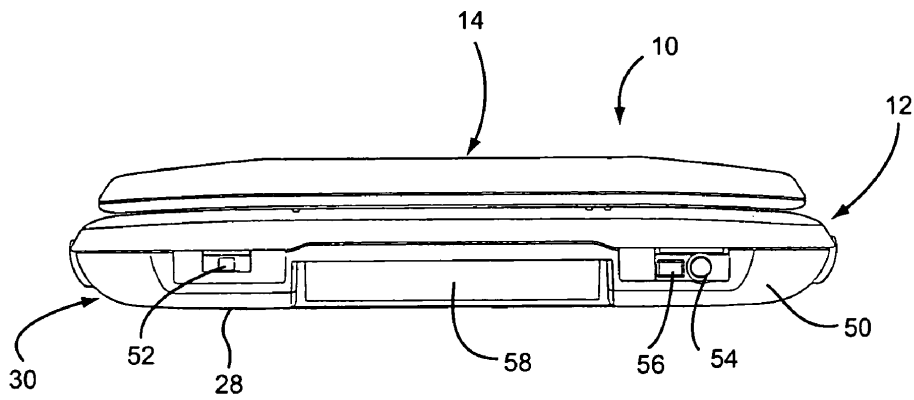

FIG. 3

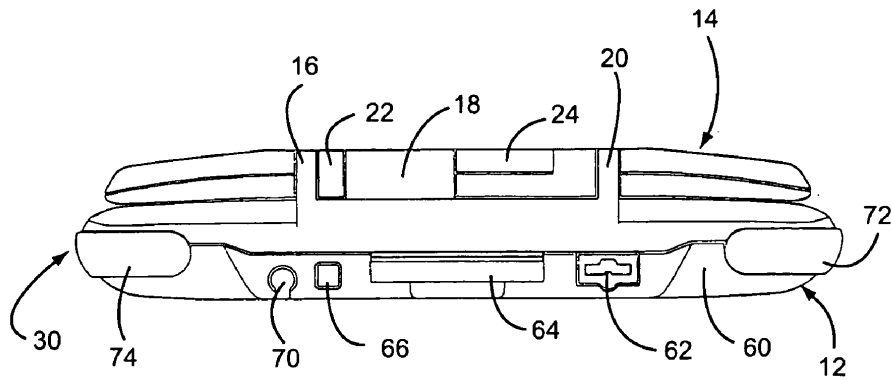
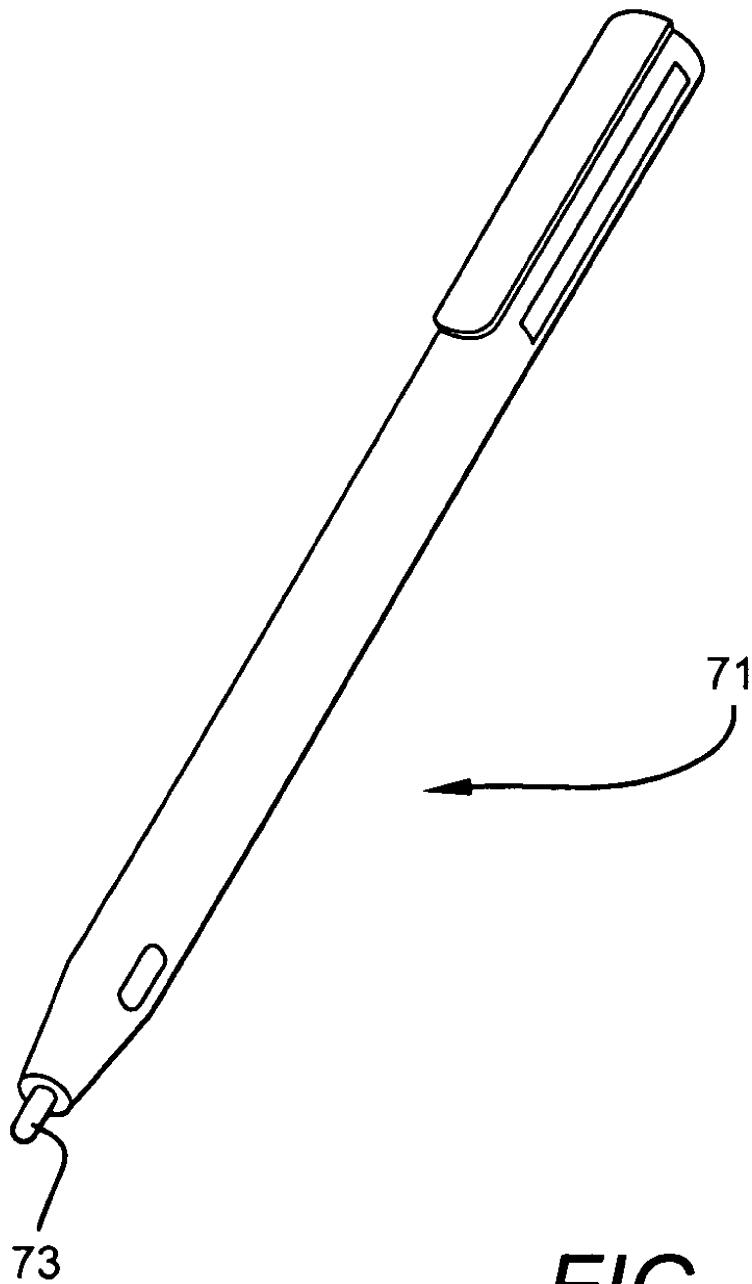

FIG. 4



**FIG. 5**

# Explore Litigation Insights

Docket Alarm provides insights to develop a more informed litigation strategy and the peace of mind of knowing you're on top of things.

## Real-Time Litigation Alerts



Keep your litigation team up-to-date with **real-time alerts** and advanced team management tools built for the enterprise, all while greatly reducing PACER spend.

Our comprehensive service means we can handle Federal, State, and Administrative courts across the country.

## Advanced Docket Research



With over 230 million records, Docket Alarm's cloud-native docket research platform finds what other services can't. Coverage includes Federal, State, plus PTAB, TTAB, ITC and NLRB decisions, all in one place.

Identify arguments that have been successful in the past with full text, pinpoint searching. Link to case law cited within any court document via Fastcase.

## Analytics At Your Fingertips



Learn what happened the last time a particular judge, opposing counsel or company faced cases similar to yours.

Advanced out-of-the-box PTAB and TTAB analytics are always at your fingertips.

## API

Docket Alarm offers a powerful API (application programming interface) to developers that want to integrate case filings into their apps.

## LAW FIRMS

Build custom dashboards for your attorneys and clients with live data direct from the court.

Automate many repetitive legal tasks like conflict checks, document management, and marketing.

## FINANCIAL INSTITUTIONS

Litigation and bankruptcy checks for companies and debtors.

## E-DISCOVERY AND LEGAL VENDORS

Sync your system to PACER to automate legal marketing.