

UNITED STATES PATENT AND TRADEMARK OFFICE

BEFORE THE PATENT TRIAL AND APPEAL BOARD

PARHELION, INC.
Petitioner

v.

STREAMLIGHT, INC.
Patent Owner

PGR Case No.: To be Assigned
U.S. Patent No. 10,378,702

DECLARATION OF KENNETH J. PUCKETT

DECLARATION OF KENNETH J. PUCKETT

EXHIBIT LIST

| Exhibit No. | Exhibit Description |
|--------------------|--|
| 1001 | U.S. Patent No. 10,378,702 (“the ‘702 patent”) |
| 1002 | File History of the ’702 patent (“the file history”) |
| 1003 | Declaration of Kenneth J. Puckett |
| 1004 | U.S. Patent No. 6,062,702 (“Krietzman”) |
| 1005 | U.S. Patent No. 8,672,513 (“Redpath”) |
| 1006 | U.S. Patent No. 9,488,331 (“the ’331 patent”) |
| 1007 | U.S. Patent No. 7,883,243 (“the ’243 patent”) |
| 1008 | U.S. Patent No. 6,694,629 (“Goodrich”) |
| 1009 | NOT USED |
| 1010 | U.S. Provisional Application No. 62/325,917 |
| 1011 | U.S. Patent No. 7,281,815 (“Gustafson”). |

I, Kenneth J. Puckett, do hereby declare and state as follows:

I. BACKGROUND AND QUALIFICATIONS

1. My business address is Laser Product Safety LLC, CARAT Laboratory, 8743 NC Highway 751, Durham, North Carolina. I earned a B.S. in Electrical Engineering from the University of North Carolina, Charlotte in 1988. I founded Underwriter's Laboratories Inc.'s (UL) first Laser and LED Optical Radiation Safety Testing and Photobiological Safety Testing Laboratory in 1992. My work in support of that effort included researching the necessary and required optical instrumentation, test, and measurement equipment to build and operate the Laboratory. I subsequently served in a variety of roles at UL, including as Engineering Manager for the first engineering section dedicated solely to optical radiation safety and photobiological safety testing, the Primary Designated Engineer (PDE) for Optical Radiation Safety and Photobiological Safety for Laser and LED based products, and the organization's first Laser Safety Officer.

2. In addition, I have worked for or collaborated with the following organizations in relation to laser technology and safety:

- The U.S. Department of Commerce on topics related to Laser Radiation Radiometric Measurement in conjunction with the University of Colorado, Boulder Colorado;
- The National Institute of Standards and Technology on laser radiation hazard calculations and safety analyses;

- The Laser Institute of America on programs related to Fundamentals of Laser Radiation Safety and Laser Safety Officer Training;
- The National Fire Protection Association (NFPA) on workforce training;
- The Rockwell Laser Institute on programs related to Laser Safety Awareness Training, Principles of Lasers Training, and laser safety requirements in the manufacturing environment; and
- Laser Professionals Inc., on ANSI Z136.1 laboratory safety control measures and safeguard implementation.

A copy of my *curriculum vitae* is attached hereto as Exhibit A.

II. ASSIGNMENT AND MATERIALS REVIEWED

3. I submit this declaration in support of Parhelion Incorporated's ("Petitioner") petition for post-grant review of U.S. Patent No. 10,378,702 ("the '702 patent").

4. I am not an employee of the Petitioner or any affiliate thereof.

5. I am being compensated for my work in connection with this proceeding at a rate of \$300 per hour, plus expenses.

6. My compensation is in no way dependent upon the substance of the opinions I offer below, or upon the outcome of the Petition for post-grant review (or the outcome of the post-grant review, if trial is instituted).

7. I have been asked to provide certain opinions relating to the patentability of the '702 patent. Specifically, I have been asked to provide my

opinion regarding: (i) the level of ordinary skill in the art to which the '702 patent pertains; (ii) whether claims 1, 2, 5, 6, 10, 11, 12, 15, 16, 22, 23, 27, and 28 are anticipated by, and/or would have been obvious over, certain prior art references; and (iii) whether claims 1, 10, 11, 20, 21, 22, 23, 24, 26, 27, and 31 are adequately enabled by the specification; and (iv) whether claims 8, 18, 20, 21, 24, and 26 are adequately enabled by the specification.

8. I have also reviewed and am familiar with any other patents, publications, and other materials discussed below.

9. In forming my opinions, I have reviewed the '702 patent and certain prior art to the '702 patent listed in the exhibits.

10. Based on my education and experience, I believe that I am qualified to render opinions in the field of laser based structured light illumination, including heat dissipation properties, and safety properties particularly as applied for human use in portable devices either alone or as part of a multi-illumination light source.

III. OVERVIEW OF THE '702 PATENT

11. The '702 patent is titled "Portable Light with Plane of a Laser Light" and names Raymond L. Sharrah, Thomas D. Boris, Donald J. Keeley as inventors. The patent issued August 13, 2019 from an application filed April 20, 2017. It claims priority to a provisional application, provisional application number 62/325,917, filed April 21, 2016.

12. I understand that the specification of a patent is the narrative description of the invention that precedes the numbered claims at the end of the patent. The '702 patent specification discusses a flashlight with a selectable white light source and a laser light source with the laser light source configured to provide structured light as a plane to create a line of laser light to illuminate objects. In particular, one use of the device is to provide illumination in environments filled with smoke, mist, particles, or fog. Ex. 1001, col. 2:15-21.

IV. THE CLAIMS OF THE '702 PATENT

13. I understand that the claims of a patent are the numbered paragraphs at the end of the patent, and that the claims define the legal scope of the invention. I also understand that patent claims may have multiple components or elements, often called "limitations."

14. I understand that there are two types of patent claims, independent claims and dependent claims. I understand that independent claims are self-contained and stand on their own. I also understand that dependent claims refer back to, or "depend from" other claims and include the limitations of the claim from which they depend. The '702 patent includes 31 claims. Claims 1, 10, 11, 22, 23, 26, 27 and 31 are independent claims. The claims of the '702 patent relate to an apparatus including both a white light source and a laser light source that generates a plane of laser light.

15. I understand that Petitioner is challenging claims 1, 2, 5, 6, 8, 10, 11, 12, 15, 16, 18, 20, 21, 22, 23, 24, 26, 27, 28, and 31 of the '702 patent (the "Challenged Claims").

V. UNDERSTANDING OF THE LAW

16. I have applied the following legal principals provided to me by counsel in arriving at the opinions set forth in this declaration. I understand that many issues concerning patents are evaluated from the perspective of a "person of ordinary skill in the art" at the time of the effective filing date of the patent. Accordingly, I will apply that standard in analyzing those issues.

A. EFFECTIVE FILING DATE OF A PATENT

17. I understand that a patent claim may receive the filing date of an earlier patent application if the patent claim is supported by the written description of the earlier application. I have been informed that a patent claim is supported by the written description of an earlier patent application only when that application reasonably conveys to one of ordinary skill in the art that the inventor had possession of the full scope of the claimed subject matter as of the filing date of the earlier application. I have further been informed that the written description requirement can be satisfied even if the application does not describe the claimed invention using the same language as the claim.

B. STANDARD FOR ANTICIPATION UNDER 35 U.S.C. § 102

18. I understand that a patent, publication, or device must first qualify as prior art before it can be used to invalidate a patent claim. I understand that if a patent was issued before the effective filing date of a patent claim, it qualifies as prior art to that claim

19. I understand that a prior art reference “anticipates” an asserted claim under 35 U.S.C. § 102, and thus renders the claim invalid, only if all elements of the claim are disclosed in that prior art reference, either explicitly or inherently. I understand that “inherently” means that, although a feature is not explicitly described, it is necessarily present in the patent. I also understand that when a prior art reference discloses a genus, or group of items, it will anticipate the individual members, or species, of the genus if the genus is of such a defined and limited class that one of ordinary skill in the art could at once envision each member of the genus. I also understand that the analysis for anticipation is a two-step process. First, the language of the disputed claim must be properly construed. Second, a comparison of the properly construed claim language to the prior art must be made on a limitation-by-limitation basis.

C. STANDARD FOR OBVIOUSNESS UNDER 35 U.S.C. § 103

20. I understand that a patent may be invalid as obvious if the differences between the claimed subject matter and the prior art are such that the subject matter

as a whole would have been obvious at the time the invention was made to a person of ordinary skill in the pertinent art. I understand that it is impermissible to use hindsight or to use the patent claims as a roadmap in performing an obviousness analysis.

21. I also understand that an obviousness determination includes the consideration of various factors such as: (1) the scope and content of the prior art, (2) the differences between the prior art and the asserted claims, (3) the level of ordinary skill in the pertinent art, and (4) the existence of objective indicia of non-obviousness or obviousness, sometimes called secondary considerations.

22. I am informed that objective indicia of non-obviousness may include: (1) a long felt but unmet need in the prior art that was satisfied by the invention of the patent; (2) commercial success or lack of commercial success of processes covered by the patent; (3) unexpected results achieved by the invention; (4) praise of the invention by others skilled in the art; (5) taking of licenses under the patent by others; and (6) deliberate copying of the invention. I also understand that there must be a relationship (a nexus) between any such objective indicia and the patent's claims.

23. I have been informed and understand that the obviousness analysis requires a comparison of the properly construed claim language to the prior art on a limitation-by-limitation basis.

D. STANDARD FOR ENABLEMENT UNDER 35 U.S.C. § 112

24. I understand that a claim in a patent is unpatentable if the specification of the application leading to the patent fails to describe the claimed invention in such a manner as to enable a person having ordinary skill in the art to make and use the invention without undue experimentation. I further understand that the scope of the enabling disclosure must be commensurate with the scope of the claim, and that several non-exhaustive factors that may be considered in determining whether experimentation is undue include (1) the quantity of experimentation necessary, (2) the amount of direction or guidance presented, (3) the presence or absence of working examples, (4) the nature of the invention, (5) the state of the prior art, (6) the relative skill of those in the art, (7) the predictability or unpredictability of the art, and (8) the breadth of the claims.

VI. SCIENTIFIC AND TECHNICAL BACKGROUND

25. I have been asked to provide a brief scientific and technical background on the technology used to generate a plane of laser light, often known as a “stripe light,” so called because when the plane of laser light is projected onto a surface such as a wall, it forms a line, or stripe, on that surface.

26. For over 30 years, laser stripe lights have been used to scan and demarcate physical objects to generate high resolution scans of 3D objects. The fundamental work on this process was done at the Carnegie Mellon University

Robotics Institute in the early 1980s. For high resolution 3D scanning applications, the process uses a computational ray plane process that sweeps the line across a surface to stack its contours and generate a map of the 3D object with a resolution of up to 0.01 mm.

27. At the time of the filing of the '702 patent (and today as well) these 3D scanning applications used a pulsed periodic Class 3R¹ laser set to invisible wavelengths at uncommon frequencies (for example, infrared 900nm) because such frequencies avoid false positive readings from environmental sources and are invisible to the human eye.

28. In addition, laser lines or stripe lights are also used for applications such as barcode scanners and laser levels.

29. To my knowledge, stripe light technology was never applied for rescue work navigation in the visible spectrum until disclosed by U.S. Patent No. 8,672,513 (“Redpath”) (Ex. 1005). Redpath discloses the use of a diffraction grating to generate a plane of light or “stripe light” at visible wavelengths suitable to assist in navigation in smoke-filled environments. Ex. 1005, col. 2:7-26.

¹ Lasers are classified by the FDA’s Center for Devices and Radiological Health (CDRH) into several classes. Under the FDA’s LN50 a Class 3R laser is a continuous wave laser, which may produce up to five times the emission limit for Class 1, or Class 2 lasers. Although the MPE can be exceeded, the risk of injury is low. The laser can produce no more than 5 mW in the visible region.

30. Stripe lights can be generated with three primary types of lenses, each with different operating characteristics and use cases. One of the simplest and most common types of lenses that can be used to generate a plane of laser light is the cylindrical lens. While relatively inexpensive, that lens is suitable only for certain applications. This is because the cylindrical type lens has a relatively high center power intensity as shown in the below photos of a barcode scanning laser. Because the line has higher power at its center, such a lens results in a line shaped like an elongated ellipse, as shown in the images below. These images were taken from the website of a supplier of laser line generators used in bar code reader applications.

See <https://picclick.com/660nm-100mW-Focusable-Red-Line-Laser-By-Cylindrical-Lens-3D-141047086551.html#&gid=1&pid=1>

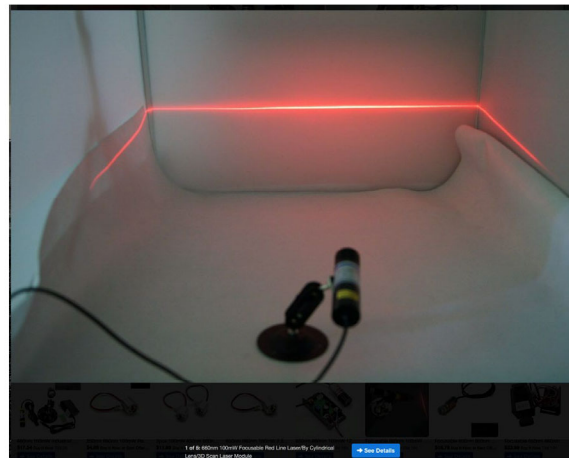
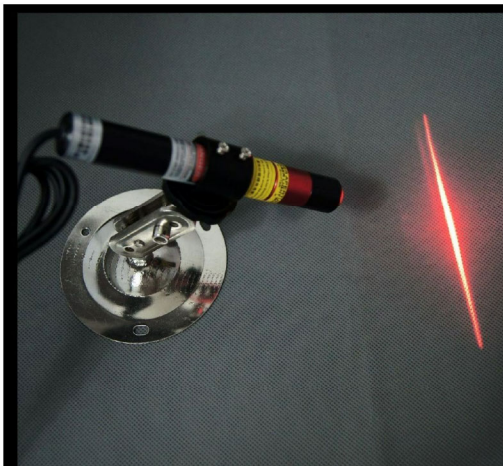

31. Because of the limitations imposed by the high center power and ellipsoidal nature of the line, the cylindrical lens is practical for closeup scanning

(barcode) applications and line level applications (e.g. for a consumer-grade laser level), but is less suitable for other applications.

32. The Powell lens and the Diffraction Optical Element, Micro-Electro-Mechanical (DOE/MEM) are additional lens types that generate a line of laser light.

33. A Powell lens has a uniform intensity except at the ends of the line of laser light. The ends of the line have relatively higher optical power.

34. A DOE/MEM lens outputs power according to a Gaussian distribution, which provides for a straight line with a more even power distribution than either a cylindrical lens or a Powell lens.

35. A conceptual representation of the relative intensity provided by each type of lens is provided below, with red circles indicating higher intensity:

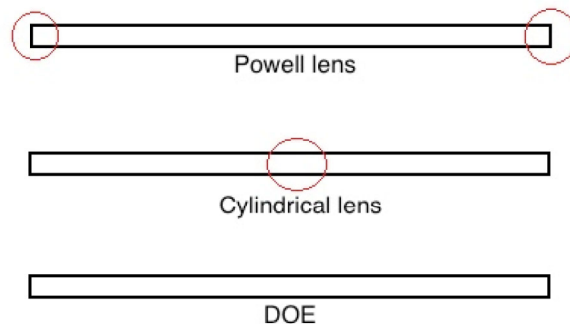

36. As illustrated above, the Powell lens has a uniform intensity except at the ends, where red circles indicate higher intensities. Accordingly, the ends have higher optical power. As noted above, the cylindrical lens has higher intensity and optical power around its center. Finally, a DOE/MEM (Diffraction Optical Element,

Micro-Electro-Mechanical) provides an intensity that follows a gaussian distribution and is far more uniform along its length than either the Powell or cylindrical lens.

37. Exemplary measurements of the percentage of line center power for each type of lens are provided in the table and photos below:

Center Power Characteristics of 0.460W Blue Laser (450nm) By Lens

| Lens Type | Exit Optic | Center 100mm | Power Down center | Photo |
|------------------|-------------------|---------------------|--------------------------|-----------------|
| Powell | 112mw | 3.77mw | 3.3% | Photo "a" Below |
| DOE | 185mw | 17.91mw | 9.6% | Photo "c" Below |
| Cylindrical lens | 381mw | 236.5mw | 62% | Photo "b" Below |

a. Powell PL75 Lens 100mm:

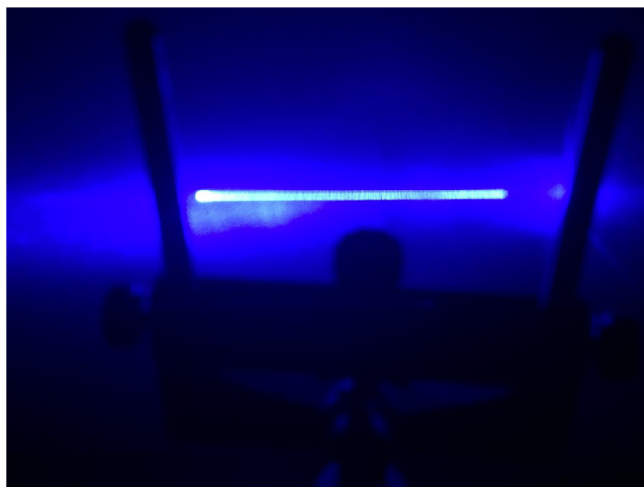

b. Cylindrical Lens 100mm:

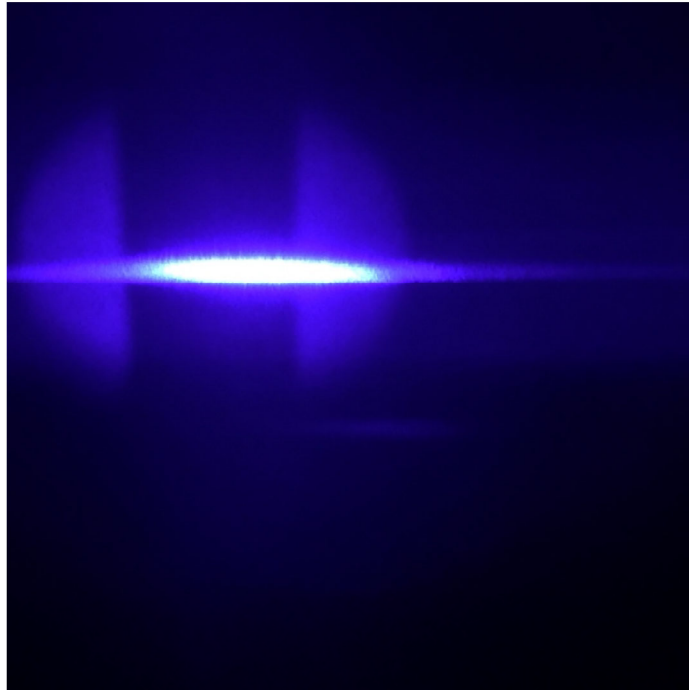

c. DOE Lens 100mm:



38. As noted above, the cylindrical lens provides a greater percentage of its optical power down its center compared to the Powell and DOE lenses. This limits the base optical power that can be used to navigate a volume of 3D space with a cylindrical lens, as explained below.

39. In order to utilize a plane of laser light to demarcate objects in 3D space for the human eye, a stripe light must balance the need for high enough optical power to be useful as a navigation aid with the need to maintain a low enough maximum power along the length of the line to avoid harming the human eye. To meet both of these requirements, a line of laser light must have around 10mw optical power at a 100mm distance to both adhere to the applicable FDA / CDRH safety requirements and provide enough illumination power to be useful for human navigation and object identification. This power level allows the optical power to be well below 5mw at a distance of 200mm, which results in a device safe for the human eye.

40. As explained below, a DOE, due to its uniform power distribution, is best suited for human navigation applications. Also as explained below, a cylindrical lens is generally unsuitable for such applications.

41. The table below shows that a DOE is best for use for this application as it has a manageable thermal power usage as well as enough optical power available for it to distribute over the entire light plane. Due to the fact that the

bulk of the power of the cylindrical lens is at the center of the laser line, in order to keep the maximum center power within safe limits for the human eye, a very low power laser must be used. Accordingly, a cylindrical lens will have approximately 13 times less power available for navigation than a DOE if it complies with CDRH safety requirements, and thus cannot be used for applications requiring navigation with the human eye.²

Parameters for Each Lens Type Needed to Generate 10mw Center Power

| Lens Type | Laser Power Required | Center Power 100mm | Comment |
|------------------|-----------------------------|---------------------------|---|
| Powell | 1220mw | 10mw | Thermal issue and waste of power to left and right; possible safety issues. |
| DOE | 256mw | 10mw | Optimal usage of power as taught in the Redpath patent (Ex. 1005). |
| Cylindrical lens | 19.5mw | 10mw | Not enough power for area and starvation of left and right of line. |

² Although a Powell lens can be made to generate a laser line with 10mw center power, due to the characteristics of the lens, very high power levels are needed, and much of the power is wasted at the periphery of the laser line away from the field of view of the user. In addition, the power of the ends of the line may exceed safe levels if the user looks in their direction. The high power requirements also require a far larger device in order to generate the additional power required and dissipate the additional heat generated by the higher power laser. Accordingly, a Powell lens is not a good choice for a navigation application.

42. As noted above, lines with uniform power suitable for navigation cannot be generated effectively with a cylindrical lens. This problem is exacerbated when a device is intended to be used in smoke-filled environments.

43. The performance of laser lines in smoke-filled environments can be evaluated with turbidity tests by passing the laser lines through water containing particulate matter.

44. Turbidity tests for each of the three types of lenses discussed above were performed according to NTU (Nephelometric Turbidity Unit) Standard EPA 180.1 (ISO 7027).

45. Turbidity measures were taken using a standard NTU 300 certified solution. Both a DOE lens according to the prior art Redpath patent and a commercial cylinder lens for a 35mw CW laser were evaluated. A red laser was chosen for ease of photography. The photograph below illustrates the optical bench setup for the test:



46. A comparison of the optical output of each lens through the NTU 300 solution follows. The image on the right illustrates how the ellipsoidal center weighted power of the cylindrical lens propagates poorly through a turbid environment. In contrast, as shown on the left, a DOE lens per the prior art Redpath patent penetrates far more effectively.³

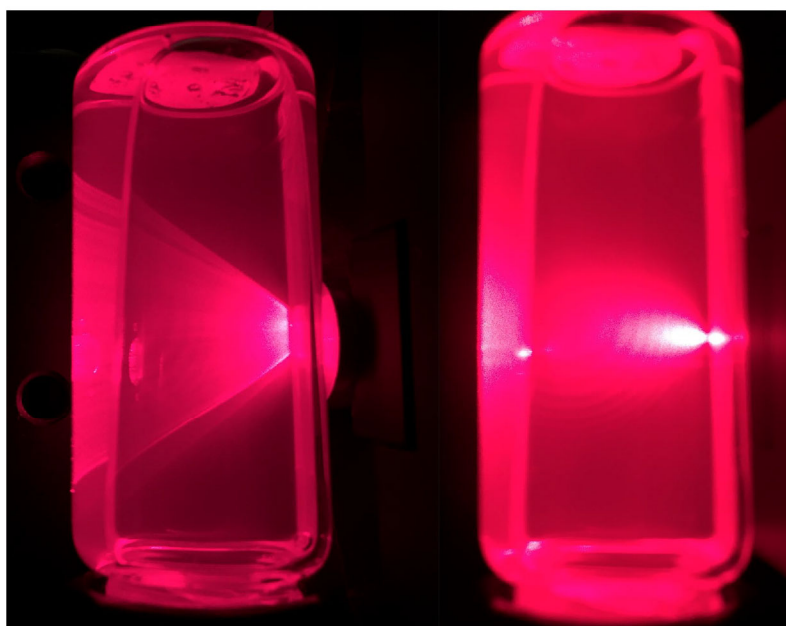

47. In the real world, these differences have substantial consequences. Due to the high concentration of its power in a center ellipsoid, much of the optical output of the cylindrical lens on the right is directed back towards the lens (and the user) in turbid or smokey environments. Accordingly, a cylindrical lens, even if it is

³ The DOE lens in the turbid environment also clearly reveals the plane of laser light generated by a straight-line generator lens.

configured at a power level to operate safely in a smoke-free environment, can cause blinding light to shine into a user's eyes when used in a smokey environment, while a DOE can operate safely in such an environment.

48. In summary, there are at least five interrelated parameters that a person of ordinary skill in the art must vary and experiment with when designing a straight-line generating laser device, as depicted in the Venn Diagram below.

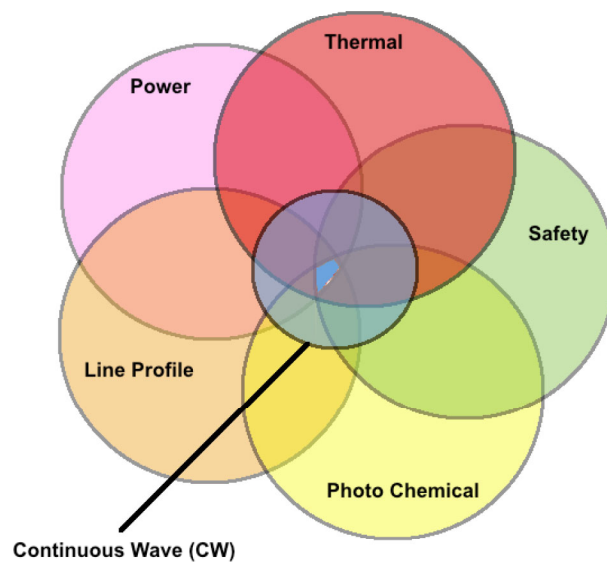

49. First, (Power): there must be enough optical power for the laser to be effective for use in 3D space by the human eye. Second (Thermal): the housing and other components must be designed to manage and dissipate the heat generated by the laser. Third (Safety): the laser power cannot exceed the maximum for human use pursuant to FDA\CDRH requirements. Fourth (Line Profile): the light plane lens must be sufficiently uniform to provide relatively equal illumination along its length.

Fifth (Photo Chemical): the wavelength must meet photo chemical wavelength safety measures at 400-600nm with all other parameters under consideration.

50. With respect to the thermal issues mentioned above, a laser light source must have a sufficient means to dissipate the heat generated by the laser in use.

51. This is usually accomplished by a dedicated heat sink structure, typically made of aluminum. A standard aluminum heat sink has thermal conductivity of $285 \text{ W/m}\cdot\text{K}$, and any laser device must have space to accommodate a heat sink that is thermally coupled to the laser diode and has sufficient capacity to dissipate the heat generated by the diode. Because a laser diode is at most 30% efficient it must dissipate at least 70% of its consumed power as heat. Because of this, heat sinks take up a substantial amount of space in laser devices, particularly for the relatively high-powered devices suitable for 3D navigation, such as Class 3R lasers.

52. In addition, laser diodes generate far more heat than LEDs, which generally dissipate substantially less than 50% of their power as heat. Accordingly, a laser diode must have a heat sink that is substantially larger than that used for a comparable LED.

VII. ANALYSIS

A. PERSON OF ORDINARY SKILL IN THE ART

53. In my opinion, a person of ordinary skill in the art at the time the invention was made would have had: (1) a bachelor's degree in electrical engineering (or a related field); and (2) either a master's degree in electrical engineering (or a related field) or five years' experience working to design and develop portable illumination devices and/or portable lasers.

B. EFFECTIVE FILING DATE

54. The '702 patent claims priority to an earlier application designated as U.S. Provisional No. 62/325,917, which was filed on April 21, 2016. Claims 8, 18, 20, 21, 24, and 26 of the '702 patent describe a "flexible" stalk and/or a "rotatable" or "rotating" laser light source. But these features are not described in the earlier patent application. Accordingly, they are not entitled to claim the earlier priority date, and their effective filing is April 20, 2017, the filing date of the '702 patent's application. However, because all prior art relied on by the Petitioner is older than the earliest priority date, and because the level of skill in the art did not change substantially between April 21, 2016 and April 2017, my analysis does not draw a distinction between the two sets of claims, and I use April 21, 2016 as the effective filing date of the Challenged Claims.

C. CLAIM CONSTRUCTION

55. In my opinion, a person of ordinary skill in the art would construe the term “cylindrical lens” as “a lens with a cylindrical surface that both receives a laser beam and emits the same laser beam as a plane of light.” This definition is consistent with the technical discussion above, where I explained the three types of lenses that can generate a line of laser light on a flat surface. It is also consistent with the ’702 patent’s specification and file history.

56. In my opinion, a person of ordinary skill in the art would construe the term “plane of laser light” as “laser light that creates a straight line on objects upon which it impinges.” This definition is consistent with the technical discussion above where I explained the history of stripe lights. It is also consistent with the ’702 patent’s specification and file history.

D. ANTICIPATION

GROUND 1

In my opinion, U.S. Patent No. 6,062,702 (“Krietzman”) anticipates claims 1, 2, 5, 6, 8, 10, 11, 12, 15, 16, 18, 22, 27, and 28. Krietzman describes a portable illumination device that includes a light bulb and a laser diode, and allows the user to select between operation of one or both of those illumination sources. Ex. 1004 at col. 5:22-25, col. 5:44-64, col. 6:45-46, and col. 7:6-9.

57. It also describes several lens types that can be used with the laser diode. Ex. 1004 at col. 4:5-14. The lenses include “straight-line generator lenses,” which a person of ordinary skill in the art would understand generate a plane of laser light.

58. Krietzman also describes the use of several types of switches, and explains that other types of switches known to a person of ordinary skill in the art can be used as well. Ex. 1004, at col. 4:20-38.

59. **Claim 1** requires a portable light comprising “a light body for receiving a source of electrical power.” Krietzman describes this feature:

- “within the upper chamber 41a are the two ends 150a & 150b of the two rows of batteries powering the flashlight are connected at the rear via the rear contact strip 65.” Ex. 1004, col. 6:23-25.

60. Claim 1 requires “a white light source supported by said light body and selectively energizable for producing white light.” Krietzman describes this feature:

- “the laser diode 100 may be activated independently or in concert with the light bulb 201” (Ex. 1004, col. 6:45-46), and “the light bulb 201 produces a generalized wide spectrum illumination.” Ex. 1004, col. 7:35-36.

61. Claim 1 requires “a laser light source supported by said light body and selectively energizable for producing laser light, wherein said laser light source includes a cylindrical lens configured for receiving light from a laser emission

element and for transmitting the received light as a plane of laser light, the cylindrical lens receiving laser light at a first part of a cylindrical surface thereof and emitting the plane of laser light from a second part of that cylindrical surface, whereby the laser light source is configured to emit a plane of laser light.” Krietzman describes this feature:

- “the laser diode 100 may be activated independently or in concert with the light bulb 201.” Ex. 1004;
- “Material choice for the discreet elements 64a & 64k include . . . straight-line generator lenses” Ex. 1004 at col. 6:66-67.

62. As described above in the technical background, a person of ordinary skill in the art would understand that Krietzman’s straight-line generator lenses necessarily produce a plane of laser light. This is because, as discussed above, in order to generate a straight line of laser light on a two-dimensional surface such as a wall, a laser must necessarily generate a plane of laser light. The intersection of the plane of laser light with the wall is what forms the line of laser light on the wall.

63. After reviewing Krietzman’s description of straight-line generator lenses, a person of ordinary skill in the art would immediately understand that the reference to straight-line generator lenses meant: (1) cylindrical lenses; (2) Powell lenses; and (3) diffraction optical elements, as described above in paragraphs 30-33. Accordingly, it is my opinion that a person of ordinary skill in the art would at once

envisage these three species of lenses after seeing the reference to the genus of straight-line generator lenses.

64. Claim 1 requires “receiving laser light at a first part of a cylindrical surface thereof and emitting the plane of laser light from a second part of that cylindrical surface.” This limitation attempts to describe the way that all cylindrical lenses work. A person of ordinary skill in the art would therefore understand that a cylindrical lens necessarily, or inherently, works this way.

65. Claim 1 requires “a switch supported by said light body for selectively energizing said white light source from the source of electrical power, and for selectively energizing said laser light source from the source of electrical power.”

Krietzman describes this feature:

- “electrical connection means is selected from the group of on/off switches consisting of momentary, push button, pressure sensitive, rotating, rotating momentary, variable resistance switches consisting of rotating, pressure sensitive, or momentary rotating.” Ex. 1004, claim 14.
- “the laser diode 100 may be activated independently or in concert with the light bulb 201.” Ex. 1004, col. 6:45-46.

66. Thus, in my opinion, Krietzman anticipates claim 1.

67. **Claim 2** states: “the portable light of claim 1 wherein the laser emission element comprises a laser diode.” Krietzman describes this feature. Specifically, it describes a removable solid state laser diode 100, (held in place within a circular diode guide 12 formed within the housing). Ex. 1004, col. 2:46-48. Thus, in my opinion, Krietzman anticipates claim 2.

68. **Claim 5** states: “the portable light of claim 1 wherein said switch is operable so that only one of said white light source and said laser light source is active at a given time.” Krietzman describes this limitation: “[t]he laser diode 100 may be activated independently or in concert with the lightbulb 201.” Ex. 1004, col. 6:45-46. Thus, in my opinion, Krietzman anticipates claim 5.

69. **Claim 6** requires “the portable light of claim 1 wherein said white light source and said laser light source emit light in substantially the same direction.” Krietzman describes this limitation in Figures 3A and 3C, which illustrate a white light source and laser light source that emit light in substantially the same direction. Thus, in my opinion, Krietzman anticipates claim 6.

Claim 8 requires “the portable light of claim 1 wherein said laser light source is supported by a shaped optical element of said white light source or is supported by a receptacle of said light body or is supported at a distal end of a flexible stalk supported by said light body.” Krietzman describes this limitation in Figs. 3A and 3C and through its description that the planar face supports the laser

lens elements 64a-64k: “within the planar face 50 are a plurality of discreet elements 64a & 64k.” Ex. 1004, col. 7:31-32. Thus, in my opinion Krietzman anticipations claim 8.

70. **Claim 10** requires “a light body for receiving a source of electrical power.” Krietzman describes this limitation: “within the upper chamber 41a are the two ends 150a & 150b of the two rows of batteries powering the flashlight are connected at the rear via the rear contact strip 65.” Ex. 1004, col. 6:23-25.

71. Claim 10 requires “a white light source supported by said light body and selectively energizable for producing white light.” Krietzman describes this limitation: “the laser diode 100 may be activated independently or in concert with the light bulb 201” (Ex. 1004, col. 6:45-46); and “the light bulb 201 produces a generalized wide spectrum illumination.” Ex. 1004, col. 7:35-36.

72. Claim 10 further recites “a laser light source supported by said light body and selectively energizable for producing laser light, wherein said laser light source includes a cylindrical lens configured for receiving light from a laser emission element and for transmitting the received light as a plane of laser light, whereby the laser light source is configured to emit a plane of laser light.” Krietzman describes a “removable solid state laser diode 100, (held in place within a circular diode guide 12 formed within the housing).” Ex. 1004, col. 2:46-48. Krietzman further discloses that “Material choice for the discreet elements 64a & 64k include . . . straight line

generator lenses” Ex. 1004 at col. 6:66-67. As discussed above in relation to claim 1, a person of ordinary skill in the art would understand that a straight-line generator lens must necessarily generate a plane of laser light. *See* Paragraph 62, above.

73. Moreover, as discussed above in Paragraph 63, a person of ordinary skill in the art would immediately understand from Krietzman’s description of straight-line generator lenses that it was describing the following species of lenses: (1) cylindrical lenses; (2) Powell lenses; and (3) diffraction optical elements. In addition, a person of ordinary skill in the art would understand that cylindrical lenses could be used when a laser line with high center power was desirable or acceptable.

74. Claim 10 further requires “a switch supported by said light body for selectively energizing said white light source from the source of electrical power, and for selectively energizing said laser light source from the source of electrical power.” Krietzman describes in Claim 14 that the “electrical connection means is selected from the group of on/off switches consisting of momentary, push button, pressure sensitive, rotating, rotating momentary, variable resistance switches consisting of rotating, pressure sensitive, or momentary rotating.” Ex. 1004, claim 14. Krietzman also describes this limitation through its description that “the laser diode 100 may be activated independently or in concert with the light bulb 201.” Ex. 1004, col. 6:45-46.

75. Claim 10 further requires “wherein said white light source includes a shaped optically clear plastic element having a polished curved external side surface and a generally wider flat forward surface oriented such that the white light exits the white light source through the flat forward surface, and wherein the laser light source is supported by the flat forward surface.” Krietzman describes this limitation in Figs. 3A and 3C and through its description that the planar face supports the laser lens elements 64a-64k: “within the planar face 50 are a plurality of discreet elements 64a & 64k.” Ex. 1004, col. 7:31-32.

76. Thus, in my opinion, Krietzman anticipates claim 10.

77. **Claim 11** is a nearly verbatim copy of claim 1, except that it requires “an illumination light source,” rather than the “white light source” of claim 1. Krietzman’s disclosure of a light bulb 201 (Ex. 1004, col. 45-46) describes this limitation, and the remaining discussion of claim 1 applies to this claim as well.

78. Thus, in my opinion, Krietzman anticipates claim 11.

79. **Claim 12** depends on Claim 11 and states that “the laser emission element comprises a laser diode.” For the same reasons as mentioned in Claim 2, Krietzman describes this limitation: “a removable solid state laser diode 100, (held in place within a circular diode guide 12 formed within the housing). Ex. 1004, col. 2:46-48.

80. Thus, in my opinion, Krietzman anticipates claim 12.

Claim 15 depends from claim 11 and states: “wherein said switch is operable so that only one of the illumination light source and laser light source is energized at a given time.” Krietzman describes in Claim 14 that the “electrical connection means is selected from the group of on/off switches consisting of momentary, push button, pressure sensitive, rotating, rotating momentary, variable resistance switches consisting of rotating, pressure sensitive, or momentary rotating.” Ex. 1004, claim 14. Krietzman also discloses this limitation through its description that “the laser diode 100 may be activated independently or in concert with the light bulb 201.” Ex. 1004, col. 6:45-46.

81. Thus, in my opinion, Krietzman anticipates claim 15.

82. **Claim 16** depends on claim 11 and states “wherein said illumination light source and said laser light source emit light in substantially the same direction.” Krietzman describes this limitation in Figures 3A and 3C, which illustrate a white light source and a laser light source that emit light in substantially the same direction. Thus, in my opinion, Krietzman anticipates claim 16.

83. **Claim 18** depends on Claim 11 and states “wherein said laser light source is supported by a shaped optical element of said illumination light source or is supported by a receptacle of said light body or is supported at a distal end of a flexible stalk supported by said light body.” Krietzman describes this limitation in Figs. 3A and 3C and through its description that the **planar face** supports the laser

lens elements 64a-64k: “within the planar face **50** are a plurality of discreet elements 64a & 64k.” Ex. 1004, col. 7:31-32.

84. Independent **claim 22** is very similar to Claim 10, except that it requires “an illumination light source” rather than a “white light source,” and it recites that the laser light source is supported by the “shaped optically clear element,” rather than the “the flat forward surface.” As these phrases are simply different ways of describing the same structures, the structures of Krietzman discussed above in relation to claim 10 also describe these features.

85. Thus, it is my opinion that Krietzman anticipates claim 22.

86. Likewise, independent **claim 27** is substantially similar to independent claims 10 and 22 except that the “shaped optical element” limitation has been removed from the end of the claim and incorporated into the second element of the claim. Accordingly, the same structures of Krietzman discussed in relation to claims 10 and 22 anticipate claim 27.

87. **Claim 28** depends on claim 27 and states “wherein the plane of laser light is emitted substantially in the predetermined direction relative to said light body, whereby the laser light source is configured to emit a plan of laser light in the same general direction as the illumination light source.” Krietzman discloses this limitation in Figures 3A and 3C. Accordingly, it is my opinion that Krietzman anticipates claim 28.

E. OBVIOUSNESS

GROUND 2

88. Although it is my opinion that a person of ordinary skill in the art would understand Kritzman's reference to the genus of "straight-line generator" lenses to include the species of: (1) a cylindrical lenses; (2) Powell lenses; and (3) diffraction optical elements (see above ¶¶ 30-33, 63), to the extent that they would not, it would certainly be obvious to a person of ordinary skill in the art to use a cylindrical lens as the straight-line generator lens of Krietzman.

89. As described above in the Scientific and Technical Background section, a person of ordinary skill in the art would understand that a cylindrical lens is a type of straight-line generator lens. They would also understand that a cylindrical lens was suitable for certain applications, where relatively high center power was acceptable, for example bar code scanners and laser levels.

90. One patent describing the use of cylindrical lenses for such applications is found in U.S. Patent No. 6,694,629, titled "Laser Projector for Producing Intersecting Lines on a Surface" ("Goodrich") (Ex. 1007). A person of ordinary skill in the art would understand from Goodrich that a cylindrical lenses is used as a type of straight-line generator lens: "It has also been known to form lines on a surface by placing a cylindrical lens in the path of a collimated laser beam, thus spreading a narrow beam of light that forms a line on a surface." Ex. 1007, 1:23-26.

91. In view of that description, it would be obvious to a person of ordinary skill in the art to use a cylindrical lens in Krietzman's device. Krietzman instructs a person of ordinary skill in the art to consider the intended use of the device when selecting a lens type. Ex. 1004, col. 3:66-4:14; 6:56-7:5. Upon reviewing that statement, a person of ordinary skill in the art would be motivated to select a cylindrical lens for applications requiring a straight line, as taught by Goodrich, because Goodrich explains that cylindrical lenses have previously been used to successfully spread a narrow beam of light that forms a line on a surface. Ex. 1007, col.1:23-29. Moreover, it would be well within the abilities of a person of ordinary skill in the art to implement such a selection because it is merely the predictable use of a cylindrical lens for its established purpose.

92. Accordingly, it is my opinion that the combination of Krietzman and Goodrich teaches a person of ordinary skill in the art to use a cylindrical lens as described in claims 1, 2, 5, 6, 8, 10, 11, 12, 15, 16, 18, 22, 27, and 28 that this combination would be obvious.

93. In addition, although it is my opinion that Krietzman would teach a person of ordinary skill in the art that the same switch can be used to selectively energize both the white light source and the laser light source, to the extent that is not the case, it would certainly be obvious to a person of ordinary skill in the art to

do so upon reviewing the teachings of U.S. Patent No. 7,281,815 titled “Lighting Device Having a Multi-Position Switch Assembly” (“Gustafson”) (Ex. 1011).

94. Gustafson describes a switch assembly for a lighting device having “a depressible switch with a rotatable portion that allows the user to activate distinct functional modes of the lighting device.” Ex. 1011, Abstract. It states that “[i]n an illustrative, non-limiting embodiment, the switch assembly 150 has three light activating positions, or channels, for three different light emitting functions.” Ex. 1011, at col. 9:20-23. Moreover, it states that “while the switch assembly 150 is described as having four positions, providing for three light activating channels and a locking channel, the number of light activating channels of the switch assembly 150 is a design choice based on the desired functionality of the flashlight 100.” Finally, it states that its switch assembly can operate “at least one light emitting diode and at least one incandescent illumination device, wherein the at least one light emitting diode and the at least one incandescent illumination device are capable of emitting visible or non-visible wavelength light.” Ex. 1011, claim 4.

95. Krietzman explicitly discloses that its laser diode 100 may be activated independently or in concert with the light bulb 201. Ex. 1001, col.6:45-46. It further discloses that a rotating momentary switch can connect to a conductive member that can be rotated into contact with the diodes to complete a circuit. *Id.* at col. 4:31-35. It also teaches that “other types of switches, momentary switches, spring loaded

switches, and locking switches well-known in the art may be used.” Ex. 1004, col. 4:37-39.

96. In view of these disclosures, it is my opinion that a person of ordinary skill in the art would be motivated to use rotating switches, such as Gustafson’s rotating switch, to tailor the design of the Krietzman device to selectively operate two light sources. Indeed, Gustafson explicitly teaches that its switch can operate two different light sources. Ex. 1011, claim 4. Combined with Gustafson’s teaching that the configuration of rotating switches “is a design choice based on the desired functionality of the flashlight,” it would have been obvious to a person of ordinary skill in the art to use Gustafson’s switch to operate the two different light sources of Krietzman. Moreover, it would be well within the abilities of a person of ordinary skill in the art to implement such a selection because it is merely the predictable use of the rotating switch for its established purpose.

97. Accordingly, it is my opinion that, to the extent that Krietzman does not disclose a switch that operates both light sources and a cylindrical lens, it would be obvious to a person of ordinary skill in the art to modify the device of Krietzman in accordance with the teachings of Goodrich and Gustafson to include those features. A person of ordinary skill in the art would be motivated to do so specifically because Krietzman instructs that “switches and locking switches well-known in the art may be used, and because it instructs that “the degree of pattern

forming or diffusion of the output” (which a person of ordinary skill in the art would understand to be a function of lens type) should be selected based on the intended use.

98. I understand that when secondary considerations of non-obviousness are present, I must review them as part of the obviousness analysis. I am unaware of any products that have a “nexus” to claims 1, 2, 5, 6, 8, 10, 11, 12, 15, 16, 18, 22, 27, and 28, and accordingly it is my opinion that those claims would have been obvious to a person of ordinary skill in the art.

F. ENABLEMENT

GROUND 3

99. In my opinion, the specification of the ’702 patent does not contain a description of the invention that would enable a person of ordinary skill in the art to practice the full scope of claims 1, 10, 11, 22, 23, 26, 27, and 31 without undue experimentation.

100. Specifically, the specification of the ’702 patent states that users include “firefighters, police, security, environmental specialists, military and other first responder personnel” Ex. 1001 at col. 1:17-20. As the ’702 patent correctly notes, such personnel often operate in environments where visibility “may be reduced by smoke, particles, fog, steam, mist, rain, snow and/or other matter suspended or floating in the air.” *Id.* at col. 1:24-26.

101. While I see nothing in the Challenged Claims of the '702 patent that limits the scope of the claim to use in such environments, it is clear from the patent's specification that the full scope of the claim must include devices that will work for their intended purpose in such turbid environments.

102. As explained below, it is my opinion, that the specification of the '702 patent does not enable a person of ordinary skill in the art to construct a device that will work in smokey environments. Accordingly, the specification of the '702 patent does not enable the full scope of the claims. I have structured my analysis of this issue below according to the *Wands* factors.

103. **First**, it is unlikely that a person of ordinary skill in the art could create such a device no matter how much experimentation they conducted. As noted above, cylindrical lenses, while appropriate for some applications, will not function effectively in the kinds of smokey environments encompassed by the claims of the '702 patent.

104. **Second**, the patent does not discuss user safety or compliance with applicable safety regulations at all. Thus, it provides no guidance as to how to create a safe plane of laser light in a smokey environment using a cylindrical lens. As noted above in paragraph 47, due to the high center power characteristics of the cylindrical lens, it would be inherently dangerous and could blind the user in such environments. Yet the '702 patent provides no guidance as to how to overcome those safety issues.

105. **Third**, I do not see any evidence that actual working examples were created that would function effectively in a smoke-filled environment. The description of the components in the '702 patent includes a 5mw laser and an acrylic PMMA or polycarbonate cylindrical lens. Ex. 1001, col. 14:5-23. In my opinion, it would not be possible to use such components to create a stripe light that would be safe and effective for 3D navigation in smoke-filled environments. A 5mw laser does not provide enough power for stripe light navigation in smokey environments. And the cylindrical lens would not work well for navigation in smokey environments due to its bias towards center power.

106. **Fourth**, as noted above, the nature of stripe lights for human navigation requires numerous tradeoffs related to power, safety, visibility, and heat management. Balancing these competing factors to create an effective device is extremely challenging, yet the '702 patent does not discuss how the inventors resolved these issues.

107. **Fifth**, the prior art indicates that the use of a cylindrical lens for navigation in smokey environments would be untenable. Specifically, Redpath, which describes such applications, uses a diffraction grating for that purpose (Ex. 1005, col. 2:26), even though cylindrical lenses were well-known at the time and far cheaper.

108. **Sixth** and **Seventh**, as to the relative skill in the art and the predictability or unpredictability of the art, I did not see evidence that these factors would impact the enablement analysis either way.

109. **Eighth**, as noted above, the claims of the '702 patent are broad enough to cover devices used for navigation in smoke filled environments, an application for which the disclosed device is not suited.

110. Considering these factors together, it is my opinion that it would require undue experimentation for a person of ordinary skill in the art to practice the full scope of claims 1, 10, 11, 22, 23, 26, 27, and 31.

Ground 4

111. It is my opinion that the specification of the '702 patent does not contain a description of the invention of claims 8, 18, 20, 21, 24, and 26 that would enable a person of ordinary skill in the art to practice their full scope. Specifically, with respect to those claims, which place a laser light source configured to emit a plane of laser light at the end of a flexible stalk, the claimed configuration will not allow for the laser light source to dissipate heat at a sufficient rate to remain operable.

112. As explained above, laser diodes dissipate heat through the use of heat sinks thermally coupled to the laser diode.

113. But the flexible stalk embodiment of these claims does not allow room for a person of ordinary skill in the art to include a heat sink of sufficient capacity to cool a laser diode, as shown in Figures 9B and 9C:

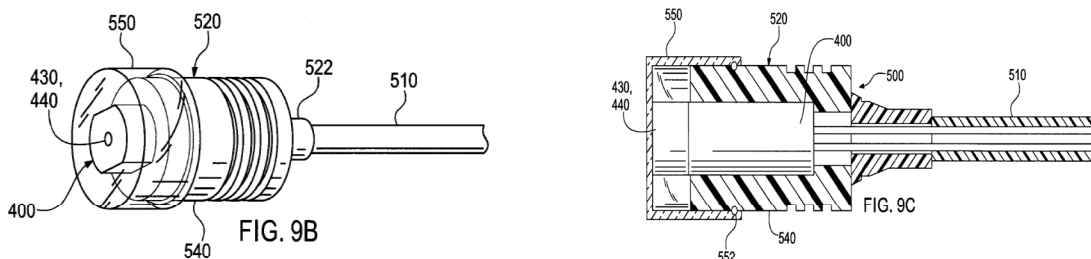

114. These figures do not show the use of a heat sink thermally coupled to the laser diode, and there does not appear to be room for such a sink in the housing. Indeed, I could not find any disclosure for a heat sink suitable for a laser diode in the specification of the '702 patent. Instead, the heat sinks described in the '702 patent relate to the LED light (i.e, the white light source or illumination light source), and not the laser diode. Ex. 1001, col. 4:61-5:11 (“LED module assembly 170 includes, e.g., a heat sink structure”); col. 14:61-67 (“One example of an LED module and heat sink of the sort suitable for use in light 100 . . . is described in U.S. Patent No. 7,883,243 . . . entitled “LED FLASHLIGHT AND HEAT SINK ARRANGEMENT.”).

115. But the '243 patent referenced by the '702 patent does not disclose a heat sink suitable for a laser diode, but rather one for an LED bulb. As noted above, LEDs do not generate as much heat as laser diodes. Thus, it is doubtful that the heat

sink of the '243 patent would work for a laser diode, especially if it is also serving as a heat sink for the LED.

116. The heat sink of the '243 patent is also quite large, as shown in Figure 4 of that patent below (the heat sink 100, is many times larger than the LED assembly 200, which would be comparable in size to the flexible stalk laser diode housing):

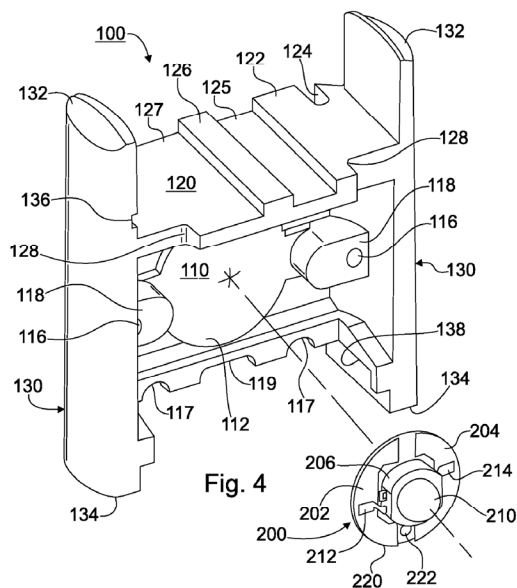

117. This kind of heat sink certainly would not fit in the flexible stalk embodiment of the '702 patent, as there is no way to couple such a large heat sink to the diode. Accordingly, the '702 patent, and the patent it references do not describe the use of a heat sink that will allow the flexible stalk embodiment to operate.

118. Once again, I have applied the *Wands* factors to evaluate the enablement question.

119. **First**, as explained above, it is unlikely that a person of ordinary skill in the art could construct a flexible stalk embodiment that would dissipate sufficient heat to function, no matter how much experimentation they conducted. There simply is not room to include such a heat sink, and the only heat sink referenced in the '702 patent is for the wrong kind of diode, for the wrong kind of device (a single illumination source), and far too large for the small housing required for the flexible stalk embodiment. And there would be nowhere for a person of ordinary skill in the art to attach such a heat sink, as the flexible stalk diode is far from the main body of the light where suitable mounting locations may be found. Thus, a person of ordinary skill in the art would have to conduct many experiments to get this embodiment to work, if they could do so at all.

120. **Second**, as discussed above, neither Figures 9B or 9C, nor the specification provide any direction or guidance as to how to fit a heat sink for a laser diode in the flexible stalk embodiment. And there does not appear to be room for such a sink in Figures 9B and 9C. Accordingly, there are no directions or guidance as to how to thermally manage the laser diode in this embodiment.

121. **Third**, there are no descriptions of tests of working samples of the flexible stalk embodiment. This is not surprising, as it is unlikely that such a device would be able to operate for very long without overheating.

122. **Fourth**, the nature of the invention involves the same design tradeoffs noted above, namely: power, safety, visibility, and heat generation. But here, heat generation becomes an almost impossible parameter to manage due to the constraints of the small flexible stalk's ability to accommodate a heat sink.

123. **Fifth**, **Sixth**, and **Seventh**, as to the state of the prior art, the relative skill in the art, and the predictability or unpredictability of the art, I did not see evidence that these factors would impact the enablement analysis either way.

124. **Eighth**, the breadth of the claims here still encompasses embodiments that must operate in a smoke-filled environment. However, it would be even more difficult to make a working embodiment with a flexible stalk due to the additional constraints imposed by the small housing for the diode.

125. Considering these factors together, it is my opinion that undue experimentation would be required to practice the full scope of claims 8, 18, 20, 21, 24, and 26 according to the specification.

I declare under penalty of perjury that the foregoing is true and correct.

Date: 04-27-2020

Signed: 
Kenneth J. Puckett

./CV

Kenneth J. Puckett, LSO

Laser Safety Officer & President, CEO, Director of Engineering

Laser Product Safety, LLC Cary, NC

<http://www.laserproductsafety.com>

office phone: 919-387-1983 mobile phone: 919-802-4121 email: kenp@laserproductsafety.com
8743 NC Highway 751
Durham, North Carolina
27713-9416 USA

Education

- BSEE Electrical Engineering. University of North Carolina, Charlotte, NC 1989 (UNCC)
 - Dept. of Mechanical Engineering: Circuit theory tutor to undergraduate students
 - NCAA Men's ice hockey team player – UNCC 49ers
- A.S. Advanced Physics. University of North Carolina, Charlotte, NC 1984
 - Dept. of Physics: Calculus tutor to undergraduate students
- North Carolina State Board of Registration For Professional Engineers, 1994

Additional Training

- U.S. Department of Commerce – Laser Radiation Radiometric Measurement, University of Colorado, Boulder Colorado
- National Institute of Standards and Technology – Laser radiation hazard calculations and safety analysis
- Laser Institute of America, Fundamentals of Laser Radiation Safety and Laser Safety Officer Training
- National Fire Protection Association (NFPA), National Electrical Code (NEC) Electrical Design, Essentials, Workforce training workshop
- Rockwell Laser Institute, Laser Safety Awareness Training
- Rockwell Laser Institute, Principles of Lasers Training
- Rockwell Laser Institute, Laser Safety Orientation Training - laser safety requirements in the manufacturing environment
- Capital Associated Industries Inc., Technical Project Management and Supervision
- Laser Professionals Inc., ANSI Z136.1 Laboratory safety control measures and safeguard implementation
- Laboratory Resource Management and Strategic Operations - STEPS program implementation, Underwriters Laboratories Inc.
- Non-ionizing radiation safety and radio-frequency radiation safety training workshop – T. Hitchcock, CIH
- Hazard Based Engineering and Product Safety Design – Research and Development Department, Underwriters Laboratories Inc.
- Switch-mode and Class 2 Power Supply design safety – Engineering Department, Underwriters Laboratories Inc.

Work Experience

Underwriters Laboratories Inc.

- **Key significant achievement:** Founder of Underwriters Laboratories Inc.'s (UL) first Laser and LED optical radiation safety testing and photobiological safety testing laboratory. Required conclusive justification by detailed business plan. Business plan was submitted for approval and agreement from UL top level business directors and General Managers of UL global offices, as well as multiple primary designated engineers and designated engineers crossing the major equipment categories. Researched the necessary and required optical instrumentation, test and measurement equipment, ANSI Z136.1 control measures and safeguard implementation to build the Laboratory. Required detailed written justification for the allocation of significant funding from UL top level management.
- Founder of Underwriters Laboratories Inc.'s Laser and LED optical radiation testing and photobiological safety testing adjunct services program
- Engineering Manager of first engineering section dedicated solely to optical radiation safety and photobiological safety adjunct testing services program: *UL RTP Section 3013-H*.
- Served as Underwriters Laboratories Inc.'s Primary Designated Engineer (PDE) for optical radiation safety and photobiological safety - laser and LED based products
- Served as Underwriters Laboratories Inc.'s first Laser Safety Officer
- Served as Underwriters Laboratories Inc.'s laser safety technical advisor to the convener of ANSI ASC Z136.1 committee
- Served as Underwriters Laboratories Inc.'s optical radiation safety technical expert representative on the US TAG and IEC TC76 committees
- Served as Underwriters Laboratories Inc.'s laser safety technical advisor to the convener of -- IEC CTL ETF2 committee
- Served as Underwriters Laboratories Inc.'s SME (subject matter expert) for ANSI Z136.1, ISO 17025 and IECEE CB scheme laser laboratory accreditation. Responsible for implementing and maintaining ANSI Z136.1 and ISO/IEC/EN 17025 laboratory accreditation.
- Developed Underwriters Laboratories Inc.'s Laser/LED Product Guideline (UL corporate laser/LED product policy)
- Served as Chief Laser and LED expert on UL's Corporate Laser/LED Safety Committee
- Served as a certified DEMKO/UL International IEC 60825 reviewing engineer, *Copenhagen, Denmark*
- Served as Underwriters Laboratories Inc.'s liaison to VDE under the UL/VDE Memorandum of Understanding (MOU) *Frankfurt, Germany*
- Underwriters Laboratories Inc.'s Certified member of Laser Institute of America (LIA)
- Served as Designated Engineer (DE) responsible for traditional product safety (risk of electric shock, fire and injury) for multiple product categories.
- Extensive product safety experience in a broad range of equipment types, i.e. Lasers, LEDs, UV sources, IR sources, Information Technology Equipment, Telecommunications, Audio/Video, Medical, Laboratory, Research, Photographic, Power Supplies, etc.

Work Experience (cont.)

Laser Product Safety, LLC

Serving in the capacity of Laser Product Safety LLC's (LPS) President, CEO and Director of Engineering, directly responsible for the company's following achievements:

May 2004 LPS partners with TÜV SÜD America Inc. establishing LPS as an Authorized Partner Testing Laboratory offering product safety testing for CE Mark and CB Certification. *Munich, Germany*

July 2004 LPS contracted to test ultraviolet Class 3B argon lasers intended for DNA testing in FBI crime labs.

October 2004 LPS invited to lecture to Physics and Engineering Department faculty of Massachusetts Institute of Technology (MIT), Cambridge, MA for laser and photobiological hazard analysis and optical radiation safety measurement techniques.

January 2005 LPS invited to present at Sparview Conference on the safety of new 3D laser scanning metrology, dimensional control and survey technologies which impact design quality, construction schedules, manufacturing costs, project safety and operations efficiency.

April 2005 LPS announces Class 1 Field Evaluation program for Certifying eligible, installed, Industrial laser systems to ANSI Z136.1.

September 2005 LPS requested to perform testing for FBI investigation of laser pointer airplane incident.

November 2005 LPS contracted to perform testing on latest Raman and EDFA combination amplifier application that can double the distance of SAN traffic over wide-area DWDM (dense wavelength-division multiplexing) networks making it the world's longest SANs (200km).

March 2006 LPS contracted to evaluate and test breakthrough precision medical device utilizing lasers to measure oxygen levels in organs.

August 2006 LPS featured in August 2006 issue of Laser Focus World magazine for testing a world class laser fishing lure.

October 2006 LPS contracted to evaluate a new near infrared laser spectralyzer used in nanotechnology, analyzing carbon nanotubes (CNT) which are a new form of carbon, configurationally equivalent to two dimensional graphene sheet rolled into a tube. CNTs are grown now by several techniques in the laboratory and are just a few nanometers in diameter and several microns long.

February 2007 LPS contracted to test an infrared Class 3B laser scanner used on the United States National Aeronautics and Space Administration (NASA) Space Shuttle Endeavour.

May 2007 LPS contracted to test an ultraviolet sniffer laser intended for biological and chemical agent detection used by the United States Department of Homeland Security.

July 2007 LPS expands testing capabilities to include Loss of Coolant Accident (LOCA), Seismic, Vibration, Shock and Strengths of Materials.

August 2007 LPS announces being equipped with a multiaxis seismic table necessary for the new multiaxis seismic testing requirements of MIL-STD-810F.

January 2008 LPS contracted to evaluate systems employed by the United States Marine Corps' Advanced Amphibious Assault Vehicle (AAAV), recently renamed the Expeditionary Fighting Vehicle (EFV). The EFV is capable of transporting 18 Marines and a crew of three over water at speeds of 29 miles an hour. On land, the EFV can achieve speeds of 45 miles an hour.

April 2008 LPS contracted to perform IEC 62471 LED eye safety testing and evaluation on the newest technology in LED solid state lighting referred to as skyceilings and luminous virtual windows. These devices employ LED lighting which illuminate opaque image tiles.

June 2008 LPS expands operations and opens a sales branch office in the USA Northwest: Corvallis, Oregon.

Work Experience (cont.)

Laser Product Safety, LLC (cont.)

September 2008 LPS contracted to perform IEC 60825 laser eye safety testing and evaluation on the newest technology in laboratory flow cytometer systems using peristaltic pumps to provide a non-pressurized, zero pulsation "push/pull" system with sophisticated microprocessor controlled dynamic feedback.

October 2008 LPS expands operations and opens a sales branch office in Southern California USA: Toluca Lake, California.

November 2008 LPS contracted to perform US FDA 21CFR and IEC 60825 laser eye safety testing and evaluation on the newest technology in infrared simulated weapons used in training by the US Military.

December 2008 LPS expands operations and opens a sales branch office in Asia: Chungli City, Taoyuan, Taiwan.

January 2009 LPS expands operations and opens a sales branch office in Europe: Copenhagen, Denmark.

March 2009 LPS partners with GlobalSpec. GlobalSpec is the leading specialized vertical search, information services and e-publishing company serving the engineering, manufacturing and related scientific and technical market segments.

May 2009 LPS announces the L Mark. The L Mark of Laser Product Safety LLC (LPS) signifies laser, LED, UV and/or IR radiation safety compliance. The L Mark on a product means that LPS has tested and evaluated representative samples of that product and determined that they meet the applicable radiation safety requirements.

July 2009 LPS contract to test the latest LED street lamps for IEC 62471 LED radiation safety compliance. The street lamps utilize ultra bright LED rated 70,000 hours (LM70).

September 2009 LPS becomes an authorized partner lab for NEMKO. NEMKO is a NCB test house under the IECEE CB Scheme and has 23 locations in 4 continents and offers market access services in over 150 countries worldwide.

November 2009 LPS contracted by the United States Navy to perform IEC 62471 testing and evaluation of LED light devices used for inspection of US Navy ships.

January 2010 LPS announces consulting services and assistance for the Incremental Seismic Rehabilitation of Hospital Buildings Manual issued by the US Department of Homeland Security and the US Federal Emergency Management Agency (FEMA). This Manual provides guidance for the protection of people and buildings from Earthquakes.

August 2010 LPS becomes an Underwriters Laboratories Inc. subcontractor testing laboratory to perform IEC 62471 testing and evaluation of LED devices.

February 2011 LPS expands operations and opens a sales branch office in Kenya, Africa.

October 2011 LPS announces software testing services: Active Test/Audit of Network systems, SCADA Security Assessment and Device Penetration Testing.

March 2012 LPS announces a Military Division of LPS dedicated to developing Innovative Technologies involving lasers for military projects.

June 2012 LPS contracted to evaluate and test an Ultra-Violet Laser Optical Screening System which reliably delineates nearly any petroleum NAPL including gasoline, diesel, crude oil, kerosene and many others. Petroleum hydrocarbons contain significant amounts of naturally fluorescent PAHs. Laser-induced fluorescence systems consistently detect them and precisely log their presence versus depth.

August 2012 LPS engaged to perform IEC/EN 62471 and ISO 15004-2 photobiological testing on an ophthalmic slit lamp microscope for irradiating a slit light strong against the transparent bodies such as the cornea and a crystalline lens from slant, carrying out optical cutting using a high brightness LED.

Work Experience (cont.)**Laser Product Safety, LLC (cont.)**

October 2012 LPS contracted by Siemens Power Generation to evaluate and test an enclosure of an 10,600nm 8.0kW industrial CO2 laser used for turbine manufacturing for Class 1 assignment. The enclosure employed high grade metal and polycarbonate windows.

November 2012 LPS contracted to evaluate and test an IR laser gesture recognition 3D camera specially tuned to see infrared light emitted by the camera creating a real time 3D image.

February 2013 LPS contracted to evaluate and test a handheld Ultra-Violet LED camera scanner assembly to IEC/EN 62471 utilized for dental imaging.

May 2013 LPS contracted to perform IEC/EN 60825-1 and 60825-2 evaluation and testing on a WSS (Wave Selective Switch). WSS is the central heart of the very latest DWDM reconfigurable Agile Optical Network. Wavelength switching can be dynamically changed through an electronic communication control interface on the WSS.

September 2013 LPS engaged to evaluate and test a Focused Beam Reflectance Measurement (FBRM) device which provides the unique ability to measure particles and droplets inline in concentrated suspensions and emulsions without the need for sample extraction.

December 2013 LPS contracted to evaluate and test a Raman Spectroscopic device to IEC/EN 60825-1 and US FDA CDRH 21CFR which derives information about secondary and tertiary protein structure by monitoring molecular vibrations.

January 2014 Laser Product Safety LLC's L Mark featured in the January 2014 issue of Laser Focus World magazine.

Committee Memberships

Currently active on the following committees and serving in the capacity of expert member directly responsible for the generation of laser safety and photobiological safety standards and technical reports.

- ANSI Accredited Standards Committee (ASC) Z136.1 SSC-1 Standard Subcommittee on Safe Use of Lasers - expert member
- ANSI Accredited Standards Committee (ASC) Z136.2 SSC-2 Standard Subcommittee on Safe Use of Optical Fiber Communications Systems Utilizing Laser Diode and LED Sources - expert member
- ANSI Accredited Standards Committee (ASC) Z136.4 SSC-4 Standard Subcommittee on Laser Measurement - expert member
- United States Technical Advisory Group Committee (US TAG), administered by the Electronic Industries Alliance (EIA) – expert member
- IECEE Committee of Testing Laboratories (CTL) Expert Task Force (ETF11) for Lasers – expert member
- IECEE Committee of Testing Laboratories (CTL) Expert Task Force (ETF5-ECS/OSM-LUM) for LEDs – expert member
- IECEE Committee of Testing Laboratories (CTL) Expert Task Force Working Group 6 (WG6) or Photobiological Safety – expert member
- IECEE International Electrotechnical Commission Technical Committee No. 76 (IEC TC76) Safety of Laser Products, Equipment Classification and Requirements - U.S. Delegate
- Working Group 3 (WG3) IECEE International Electrotechnical Commission Technical Committee No. 76 (IEC TC76) Optical Radiation Measurement for Classification of Laser Products – expert member
- Working Group 5 (WG5) IECEE International Electrotechnical Commission Technical Committee No. 76 (IEC TC76) Safety of Optical Fiber Communication Systems (OFCS); Safety of Free Space Optical Fiber Communication Systems (FSOCS) and Safety Aspects for Use of Passive Optical Components and Optical Cables in High Power Optical Fiber Communication Systems – expert member
- Working Group 12 (WG12) IECEE International Electrotechnical Commission Technical Committee No. 76 (IEC TC76) Laser Safety Protective Eyewear

Partial List of Presentations

- Massachusetts Institute of Technology (MIT) Cambridge, MA, Lecture to Department of Engineering and Department of Physics Faculty on Laser Safety in Laboratories and Laser Measurement and Hazard analysis
- Rockwell Institute, Training on Laser Safety regulations and the IECCEB Scheme to Rockwell staff consultants
- Sparview Conference 2005, Laser Safety regulations and 3D Scanning Hardware
- Apex Testing Laboratory Isu, Japan, Laser Safety regulations, Laser measurement and hazard analysis to Engineering staff
- DEMKO Copenhagen, Denmark, Laser Safety regulations, Laser measurement and hazard analysis to Engineering staff
- Canadian Standards Association (CSA) Toronto, Canada, Laser safety and photobiological safety measurement and hazard analysis
- Verband der Elektrotechnik, Elektronik und Informationstechnik e.V. (VDE) Frankfurt, Germany, Laser Safety regulations to Engineering Staff.
- NCB TÜV SÜD Product Service GmbH Ridlerstrasse 65, 80339 Munich, Germany, Laser Safety and Photobiological Safety regulations to Engineering Staff.
- Norges Elektriske Materiekkontroll (NEMKO) Oslo, Norway. Laser Safety and Photobiological Safety regulations to Engineering Staff.
- Global Knowledge Transfer, Presentation to UL CEO and UL top level management for transfer of laser safety adjunct services and training to global offices
- Laser safety Training to Underwriters Laboratories Inc. (UL) North American Laser and LED Product Designated Engineers
- Laser safety Training to Underwriters Laboratories Inc. (UL) European Laser and LED Product Designated Engineers
- Laser safety Training to Underwriters Laboratories Inc. (UL) Asian Laser and LED Designated Engineers

Awards

- Underwriters Laboratories Inc. Research Triangle Park, NC, Engineering Department - Founder of Laser and LED Adjunct Services Award 1999
- National Leadership Award – Business Advisory Council, Washington D.C. 2003
- Underwriters Laboratories Inc. Research Triangle Park, NC, Engineering Department - Excellence in Leadership Award 1996
- Underwriters Laboratories Inc. Research Triangle Park, NC, Engineering Department - Client Satisfaction Award 1997

Publications

- Boden P., Puckett K., Safety, Compliance & Regulation – The Gateway for Laser-based Products into the Marketplace. Medical Design Briefs, September 2014.
- Puckett K., Consumer Photonics Laser Appeal. Laser Focus World, August 2006.
- Underwriters Laboratories Inc., UL Laser and LED Product Safety Guideline, January 2001.
- Puckett K., L Mark of Laser Product Safety LLC, Compliance with Laser and Photobiological Safety Regulations. Laser Focus World, January 2014.