



US 20120075425A1

(19) **United States**

(12) **Patent Application Publication**
Thiel

(10) **Pub. No.: US 2012/0075425 A1**

(43) **Pub. Date: Mar. 29, 2012**

(54) **HANDHELD DENTAL CAMERA AND METHOD FOR CARRYING OUT OPTICAL 3D MEASUREMENT**

Publication Classification

- (51) **Int. Cl.**
H04N 13/02 (2006.01)
- (52) **U.S. Cl.** 348/46; 348/E13.074
- (57) **ABSTRACT**

(75) **Inventor: Frank Thiel, Ober-Ramstadt (DE)**

(73) **Assignee: Sirona Dental Systems GmbH, Bensheim (DE)**

(21) **Appl. No.: 13/213,893**

(22) **Filed: Aug. 19, 2011**

Related U.S. Application Data

(63) Continuation of application No. PCT/EP2010/052241, filed on Feb. 23, 2010.

Foreign Application Priority Data

Feb. 23, 2009 (DE) 10 2009 001 086.6

A handheld dental camera performs three-dimensional, optical measurements. The camera includes a light source that emits an illuminating beam, a scanning unit, a color sensor, and a deflector. The scanning unit focuses the illuminating beam onto a surface of an object to be measured. The surface of the object reflects the illuminating beam and forms a monitoring beam, which is detected by the color sensor. Focal points of wavelengths of the illuminating beam form chromatic depth measurement ranges. The scanning unit stepwise displaces the chromatic depth measurement ranges by a step width smaller than or equal to a length of each chromatic depth measurement range, so that a first chromatic depth measurement range in a first end position of the scanning unit and a second chromatic depth measurement range in a second end position are precisely adjoined in a direction of a measurement depth, or are partially overlapped.

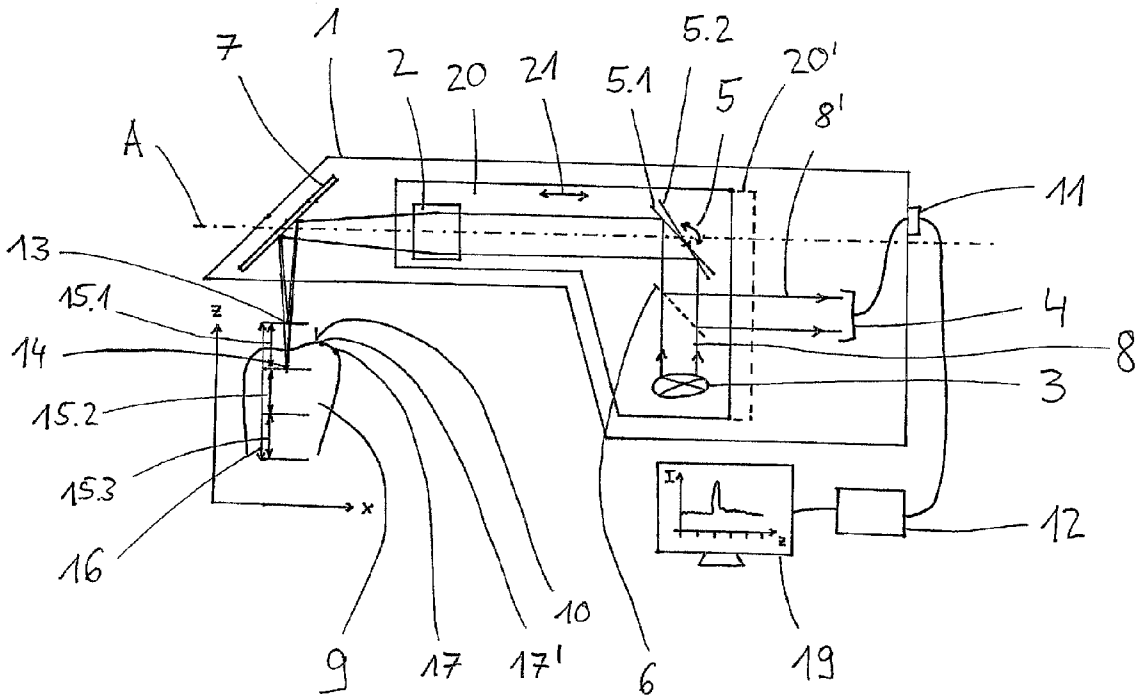

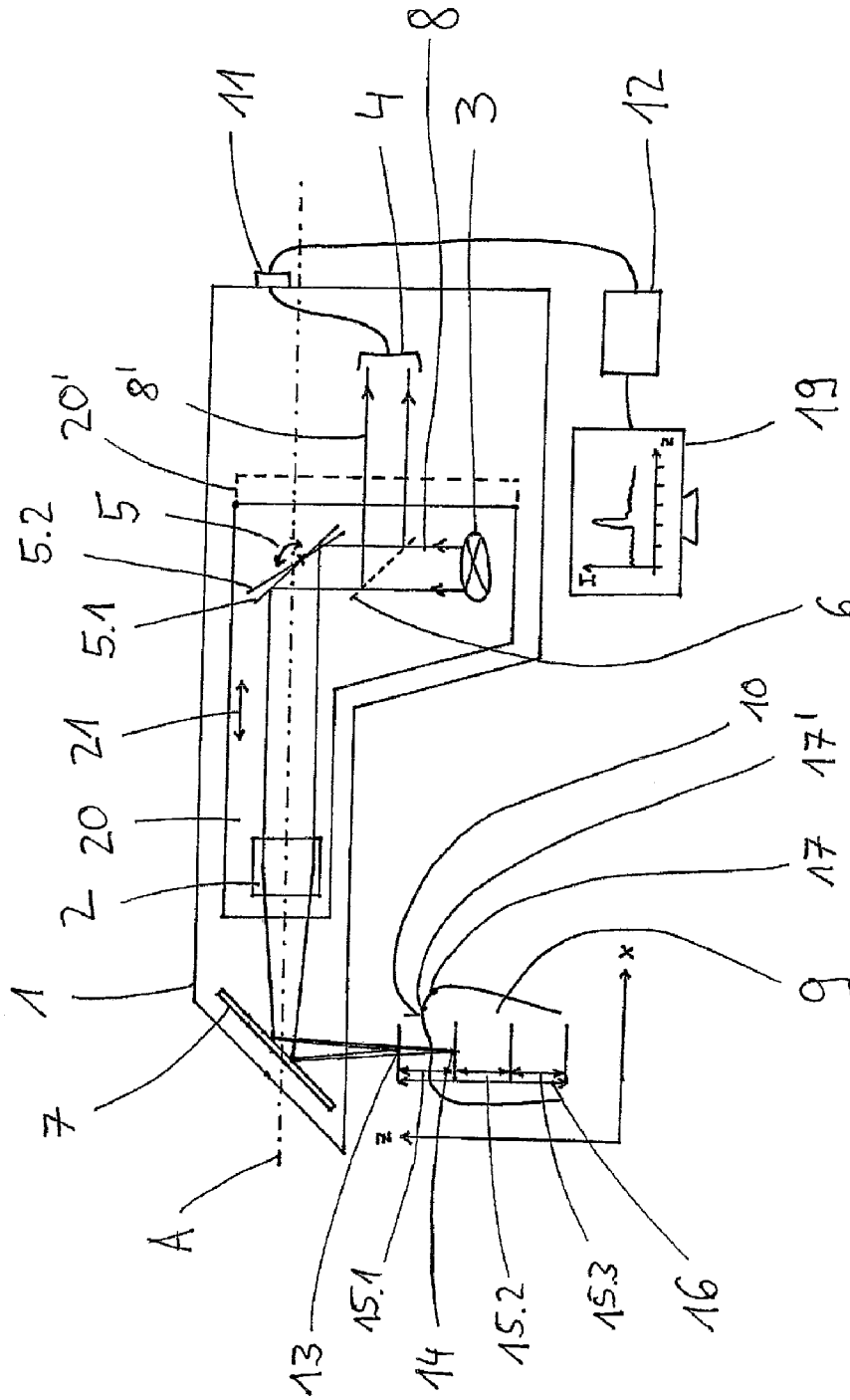

Fig. 1

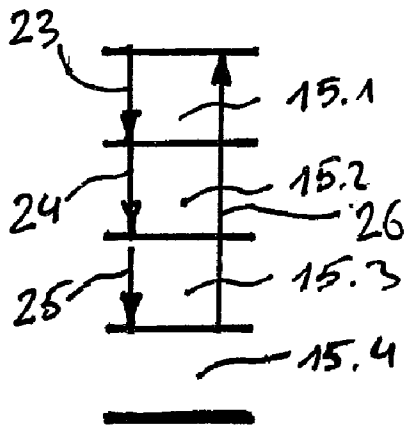

Fig. 2

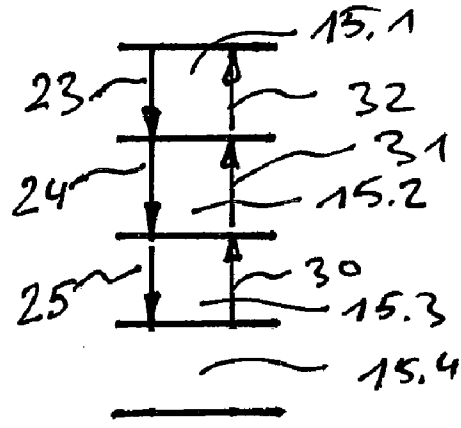

Fig. 3

HANDHELD DENTAL CAMERA AND METHOD FOR CARRYING OUT OPTICAL 3D MEASUREMENT

RELATED APPLICATIONS

[0001] This application is a continuation of International Application PCT/EP2010/052241, filed Feb. 23, 2010, claims benefit of the filing date of that application under 35 U.S.C. §120, and claims benefit under §119 of German Application No. 10 2009 001 086.6, filed Feb. 23, 2009. The entire contents of those two applications are incorporated herein by reference.

TECHNICAL FIELD

[0002] The invention relates to a handheld dental camera for carrying out optical 3D measurement using a confocal measuring method, which handheld dental camera comprises a chromatic objective, a polychromatic light source, and a color sensor, and also to a method for using the dental camera of the invention.

PRIOR ART

[0003] Confocal microscopy is well-known in the prior art and is disclosed, inter alia, in the patent specification U.S. Pat. No. 3,013,467.

[0004] The chromatic confocal measuring method provides the possibility of effecting focusing without the need for mechanically moving components, and as a result usually reduce measuring time significantly, as was proposed by G. Molesini in 1983 in conjunction with a spectrometer (GB 2144537 and DE 3428593 C2). An example of successful application of the chromatic confocal measuring method is described by H. J. Tiziani and H.-M. Uhde in the professional article "Three-dimensional image sensing by chromatic confocal microscopy" in *Applied Optics*, Vol. 33, No. 1, April 1994, pp. 1838 to 1843. In this case, the spectral analysis is performed by means of three color filters. Thus the depth measurement range and the depth resolution achievable in this application are limited.

[0005] The patent specification DE 103 21 885 AI discloses a chromatic confocal system comprising a component having variable refractive power, for example, a diffractive component. In the optical arrangement shown in FIG. 2 of said patent specification, a series of micro-lenses is provided for illumination in order to obtain the confocal signals via the wavelength, and, for analysis, a spectrometer comprising an area scan camera is disposed downstream so that line profiles can be obtained from a single planar camera image by means of a line spectrometer. In the publication "Chromatic confocal detection for speed micro-topography measurements" by A. K. Ruprecht, K. Koerner, T. F. Wiesendanger, H.J. Tiziani, W. Osten in *Proceedings of SPIE*, Vol. 5302-6, pp. 53-60, 2004, FIG. 4 shows a chromatic confocal line sensor for topographic measurement. In this case, in order to obtain the confocal signals via the wavelength, a line spectrometer is disposed downstream of the chromatic confocal system so that line profiles of the surface of an object can be ascertained from a single camera image using a single area scan camera and a line spectrometer. The use of a spectrometer basically allows for higher spectral resolution compared with an arrangement comprising three color filters or an RGB color

[0006] On pages 12 and 13 of the dissertation entitled "3D-Spektrofotometrie extragalaktischer Emissionslinien" [3D-Spectrophotometry of extragalactic emission lines] by J. Schmol, submitted to the University of Potsdam in June 2001, lenticular direct coupling is described, which was first applied in the TIGER spectrograph by Courtes et al. in 1988. In said citation, the lenticular raster is rotated through an angle counter to the direction of dispersion. Because of the shift of adjacent spectra, this technique has the reputation of being complicated for evaluation purposes, and the area of the area sensor is not utilized economically, because the filling factor is low. In scientific papers, terms such as 3D-spectrophotometry and imaging spectroscopy and integral-field spectrophotometry are also used in this connection.

[0007] The chromatic confocal measuring method has the advantage that the camera can, in principle, be one not having any mechanically moving components, and that the data rate is low, since only a single color spectrum needs to be recorded for any one measuring point.

[0008] However, the disadvantage of the chromatic confocal measuring method is that a spectral broadband light source must be used that has a wavelength spectrum that is as broad and continuous as possible. Therefore, primarily halogen lamps and xenon gas-discharge lamps are suitable for use as the light source. These light sources are comparatively unwieldy and large, due to their design. A compact light source such as a laser diode or a super-luminescent diode is less suitable for the chromatic confocal measuring method, since it typically has a rather narrow wavelength spectrum. The depth measurement range is therefore greatly restricted and not suitable for measuring relatively large objects such as teeth.

[0009] In a classical scanning confocal measuring method with mechanical depth measurement, the position of a single focal point is moved by mechanically moving individual lens elements of the optical system or by moving the entire optical system relatively to the object. The light source used is one that has the narrowest possible wave spectrum in order to keep the area of the focal point small. For scanning a single measuring point, the optical system must thus be mechanically moved, in steps, over the entire measurement depth, a data set being acquired for each position of the optical system and an elevation value then determined from all of the data sets acquired. The resolution of the elevation values depends on the width of the individual mechanical steps carried out for moving the optical system. Therefore, the classical scanning confocal measuring method suffers from the shortcoming that very large amounts of data accumulate that have to be processed for the purpose of carrying out good resolution.

[0010] The classical scanning confocal measuring method has the advantage that compact light sources such as LEDs and LDs can be used that have a narrow-band wavelength spectrum.

[0011] The object of this invention is to provide a confocal apparatus and a confocal method that makes it possible to carry out rapid optical 3D measurement of the object to be measured, in which confocal method it is possible to use a compact light source and the data rates are low.

SUMMARY OF THE INVENTION

[0012] This object is achieved by means of the handheld

[0013] The handheld dental camera of the invention for carrying out optical 3D measurement comprises a chromatic objective, a polychromatic light source, and a color sensor, in which handheld dental camera the polychromatic light source emits an illuminating beam (8) that can be focused, at least in terms of one wavelength thereof, onto the surface of an object of interest by means of the chromatic objective. The illuminating beam is reflected by the surface to form a monitoring beam, which is capable of being detected by means of the color sensor. The focal points of the various wavelengths of the illuminating beam form a chromatic depth measurement range.

[0014] The handheld dental camera further comprises an movable scanning unit comprising at least the chromatic objective. The chromatic depth measurement range can be moved in steps by means of the scanning unit so that at least a second chromatic depth measurement range in a second position of the scanning unit adjoins a first chromatic depth measurement range in a first position of the scanning unit or at least partly overlaps the first chromatic depth measurement range. In this manner, an enlarged overall depth measurement range is formed from the at least two different depth measurement ranges.

[0015] The handheld dental camera for carrying out optical 3D measurement can be a handheld camera that is particularly suitable for producing dental intraoral images of teeth and that combines the principles of chromatic confocal depth measurement and scanning confocal depth measurement.

[0016] In the chromatic confocal measuring method, the measurement is carried out without mechanically moving the optical system in that the focal points of different wavelengths are distributed over the entire measurement depth and use is made of spectral analysis to ascertain the wavelength of which the focal point is located on the surface. The focal position, that is, the z coordinate of the object surface can be ascertained from this wavelength. The resolution of the z coordinate depends primarily on the continuous distribution of wavelengths in the spectrum of the illuminating beam used, and on the precision of the spectral analysis used.

[0017] For this purpose, a polychromatic light source is used, of which the spectral range emitted in the form of the illuminating beam has a plurality of wavelengths. This illuminating beam is focused by means of a chromatic objective onto the object to be measured. Since a chromatic objective intensifies the effect of chromatic aberrations, the focal points for the different wavelengths of the illuminating beam are kept well apart. The focal points of the shortest and longest wavelengths of the spectral range of the illuminating beam can be spaced from each other by up to 5 mm, and they form the chromatic depth measurement range of the handheld dental camera. An elevation value can be assigned to each wavelength within this chromatic depth measurement range.

[0018] As a result of this separation of the focal points, only the focal point of a single wavelength or at least a very narrow wavelength range of the spectral range of the illuminating beam is located exactly on the surface of the object of interest, and this wavelength dominates the spectral intensity profile of the monitoring beam.

[0019] The monitoring beam is detected by means of a color sensor capable of detecting a broad spectral range and of differentiating the individual wavelengths. A spectrometer or a CCD sensor is suitable for this purpose.

tion value corresponding to this wavelength can be assigned to the measuring point on the surface as long as the measuring point is located within the chromatic depth measurement range.

[0021] In the present invention, use is made of compact polychromatic light sources such as LEDs, laser diodes (LDs), and super-luminescent diodes (SLDs), of which the wavelength spectrum is narrow compared with halogen lamps or xenon gas-discharge lamps. In order to still make it possible to measure a sufficiently large depth measurement range, the chromatic confocal measuring method is combined with the classical scanning confocal measuring method.

[0022] In the scanning confocal measuring method, a single focal point is moved along the measurement depth by mechanically moving the optical system stepwise, and the detected intensities of the monitoring beam are used to identify that step of the mechanical movement of the optical system in which the focal point is located exactly on the surface of the object to be measured. The focal position can then be ascertained from the step in which a maximum intensity of the illuminating beam is detected. The resolution of the z coordinate, i.e. the elevation value, is ascertained in this method by means of the step width of the mechanical movement of the optical system.

[0023] By means of the scanning unit in the handheld dental camera, which scanning unit comprises at least the chromatic objective, the plurality of focal points that are kept apart by the use of the polychromatic light source and the chromatic objective can be moved at the same time over the depth measurement range. The step width can be such that it is equal, as precisely as possible, to the length of the chromatic depth measurement ranges. Thus it is possible for several chromatic depth measurement ranges that adjoin or overlap each other along the z axis to be measured successively and a 3D data set to be acquired for an enlarged overall depth measurement range from the data sets thus acquired. This enlarged depth measurement range is given by the sum of the chromatic depth measurement ranges that adjoin or overlap each other. For example, a chromatic depth measurement range that can be achieved by means of a compact light source such as an LED, LD, or SLD can have a length of 0.5 mm. If an overall depth measurement range of 20 mm is to be measured, this measurement can be carried out in 40 steps having a step width of 0.5 mm.

[0024] It is thus possible, in spite of a narrow chromatic depth measurement range, to achieve a measurement depth that makes it possible to scan an object such as a tooth.

[0025] One advantage of the handheld dental camera of the invention over the purely chromatic confocal method is the ability to use more compact light sources such as LEDs, LDs, and SLDs, since a narrower spectral range $\Delta\lambda$ is sufficient. It is therefore possible to dispense with the unwieldy and large light sources such as halogen lamps and xenon gas-discharge lamps that are used typically in the chromatic confocal measuring method.

[0026] A further advantage of the handheld dental camera of the invention is that the number of mechanical steps required for moving the scanning unit is significantly smaller than in the purely scanning confocal method and thus the amount of data to be processed is also significantly reduced.

[0027] Advantageously, the scanning unit can be moved to

Explore Litigation Insights

Docket Alarm provides insights to develop a more informed litigation strategy and the peace of mind of knowing you're on top of things.

Real-Time Litigation Alerts



Keep your litigation team up-to-date with **real-time alerts** and advanced team management tools built for the enterprise, all while greatly reducing PACER spend.

Our comprehensive service means we can handle Federal, State, and Administrative courts across the country.

Advanced Docket Research



With over 230 million records, Docket Alarm's cloud-native docket research platform finds what other services can't. Coverage includes Federal, State, plus PTAB, TTAB, ITC and NLRB decisions, all in one place.

Identify arguments that have been successful in the past with full text, pinpoint searching. Link to case law cited within any court document via Fastcase.

Analytics At Your Fingertips



Learn what happened the last time a particular judge, opposing counsel or company faced cases similar to yours.

Advanced out-of-the-box PTAB and TTAB analytics are always at your fingertips.

API

Docket Alarm offers a powerful API (application programming interface) to developers that want to integrate case filings into their apps.

LAW FIRMS

Build custom dashboards for your attorneys and clients with live data direct from the court.

Automate many repetitive legal tasks like conflict checks, document management, and marketing.

FINANCIAL INSTITUTIONS

Litigation and bankruptcy checks for companies and debtors.

E-DISCOVERY AND LEGAL VENDORS

Sync your system to PACER to automate legal marketing.