

- 24 : 第3結像レンズ
- 25 : 第2受光素子
- L1 : レーザ光又は高輝度ランプ
- L2 : 白色光
- D-1 : 第1結像レンズの駆動機構
- D-2 : 第3結像レンズの駆動機構

【図1】

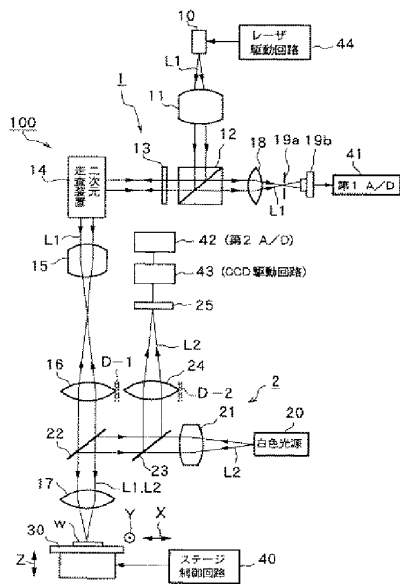

【図2】

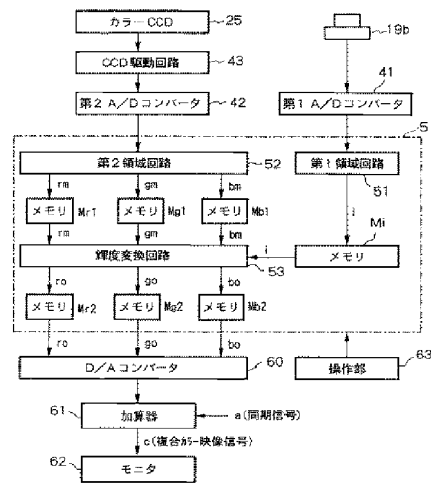

Align Ex. 1002 (Part 2 of 3)
 U.S. Patent No. 9,962,244

【図3】

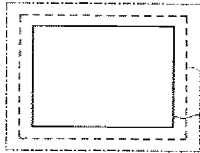

【図4】

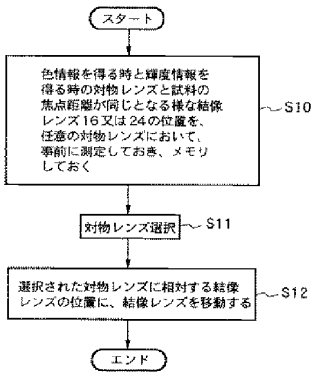

【図6】

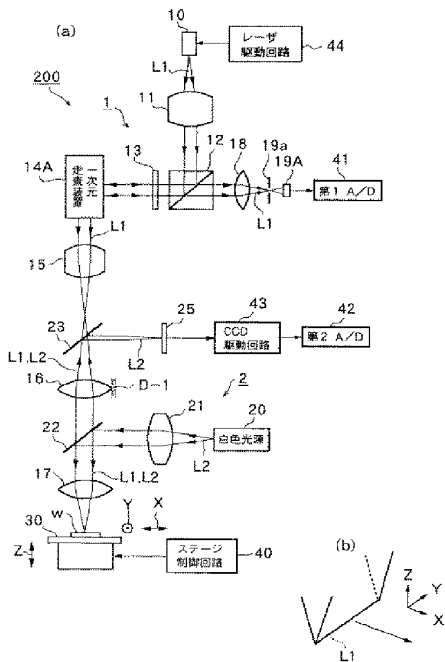

【図5】

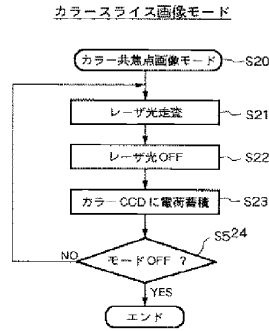

【図7】

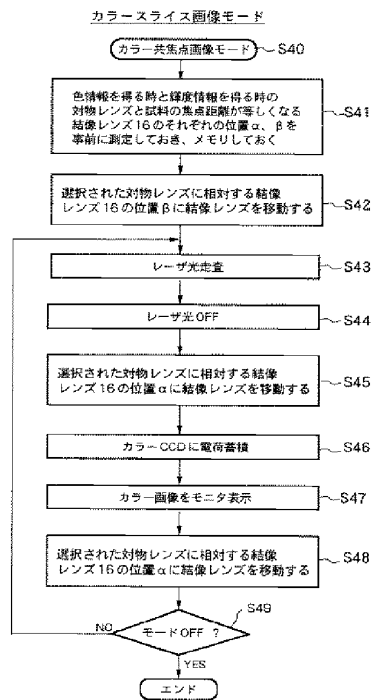

【図8】

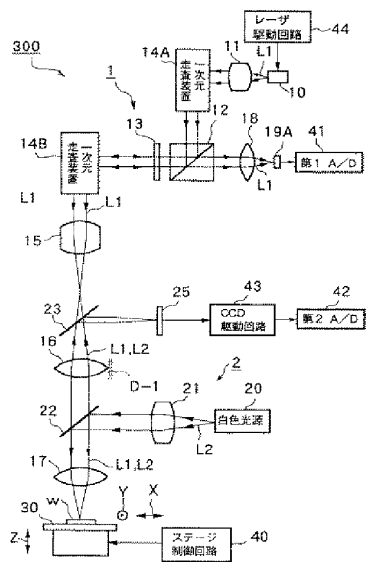

【図9】

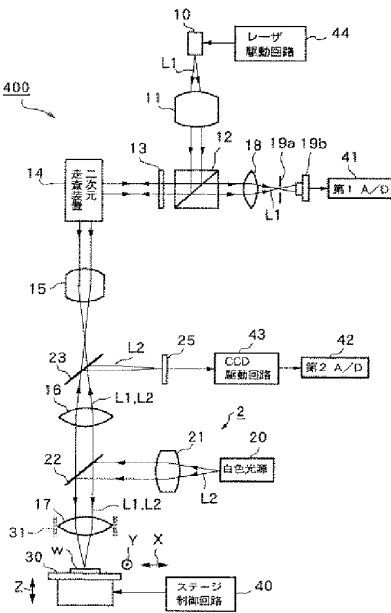

(72)発明者 中務 貴司

大阪府大阪市東淀川区東中島1丁目3番14号

株式会社キーエンス内

Fターム(参考) 2H052 AA08 AB17 AB21 AB24 AC07 AC12 AC14 AC15 AC16 AC33
AC34 AD05 AD06 AD18 AD35 AF02 AF06 AF14



(11) **EP 2 241 248 A2**

(12) **EUROPEAN PATENT APPLICATION**

(43) Date of publication:
20.10.2010 Bulletin 2010/42

(51) Int Cl.:
A61B 5/00 (2006.01) A61B 1/24 (2006.01)

(21) Application number: **10007060.6**

(22) Date of filing: **09.01.2009**

(84) Designated Contracting States:
DE ES FI FR GB IT

• **Inglese, Jean-Marc**
77437 Bussy Saint Georges (FR)

(30) Priority: **11.01.2008 US 972907**

(74) Representative: **Wagner, Karl H.**
Wagner & Geyer Partnerschaft
Patent- und Rechtsanwälte
Gewürzmühlstrasse 5
80538 München (DE)

(62) Document number(s) of the earlier application(s) in accordance with Art. 76 EPC:
09000250.2 / 2 078 493

(71) Applicant: **Carestream Health, Inc.**
Rochester, NY 14608-1733 (US)

Remarks:

This application was filed on 08 07 2010 as a divisional application to the application mentioned under INID code 62.

(72) Inventors:
• **Liang, Rongguang**
Penfield, New York 14526 (US)

(54) **Intra-oral camera for diagnostic and cosmetic imaging**

(57) An apparatus for obtaining images of a tooth comprises at least one image sensor disposed along an optical axis to take polarized reflectance image and fluorescence image, at least one broadband illumination apparatus for reflectance imaging, and a narrow-band

ultraviolet illumination apparatus for fluorescence imaging. In order to remove the specular reflection, one or more polarization elements are disposed along the optical axis. A filter is disposed along the optical axis to block narrow-band ultraviolet light, and a switch for selecting one of the operation modes.

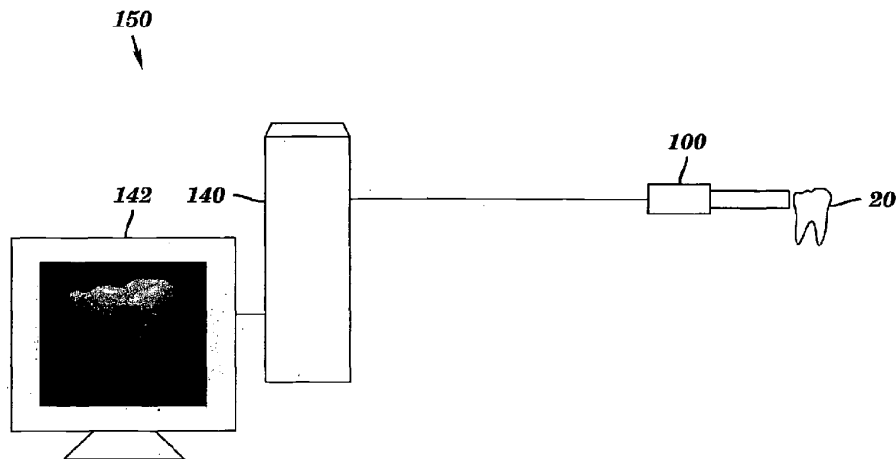

FIG. 1

EP 2 241 248 A2

Description**FIELD OF THE INVENTION**

[0001] This invention generally relates to methods and apparatus for dental imaging and more particularly relates to an intra-oral camera apparatus that includes capabilities for caries detection as well as for shade matching.

BACKGROUND OF THE INVENTION

[0002] Digital imaging has been adapted to serve dentistry for both diagnostic and cosmetic purposes. For example, there have been a number of dental imaging systems developed for diagnosis of dental caries in its various stages, capable of assisting in this diagnostic task without the use of x-rays or other ionizing radiation. One method that has been commercialized employs fluorescence, caused when teeth are illuminated with high intensity blue light. This technique, termed Light-Induced Fluorescence (LIF), operates on the principle that sound, healthy tooth tissue yields a higher intensity of fluorescence under excitation from some wavelengths than does de-mineralized tooth tissue that has been damaged by caries infection. The strong correlation between mineral loss and loss of fluorescence for blue light excitation is then used to identify and assess carious areas of the tooth. A different relationship has been found for red light excitation, a region of the spectrum for which bacteria and bacterial by-products in carious regions absorb and fluoresce more pronouncedly than do healthy areas. Utilizing this behavior, U.S. Patent No. 4,290,433 entitled "Method and Apparatus for Detecting the Presence of Caries in Teeth Using Visible Luminescence" to Alfano discloses a method to detect caries by comparing the excited luminescence in two wavelengths. The use of fluorescence effects for caries detection is also described in U.S. Patent No. 6,231,338 entitled "Method and Apparatus for the Detection of Carious Activity of a Carious Lesion in a Tooth" to de Josselin de Jong et al.

[0003] Reflectance characteristics of visible light have also been used for oral caries diagnosis. For example, U.S. Patent No. 4,479,499 entitled "Method and Apparatus for Detecting the Presence of Caries in Teeth Using Visible Light" to Alfano describes a method to detect caries by comparing the intensity of the light scattered at two different wavelengths. Commonly assigned U.S. Patent Application Publication 2007/0099148, previously mentioned, describes an improved method for caries detection that combines both fluorescence and reflectance effects.

[0004] Among commercialized products for diagnostic dental imaging using fluorescence behavior is the QLF Clinical System from Inspektor Research Systems BV, Amsterdam, The Netherlands, described in U.S. Patent 6,231,338. Using a different approach, the Diagnost Laser Caries Detection Aid from KaVo Dental GmbH,

Biberach, Germany, described in U.S. Patent 6,024,562, detects caries activity monitoring the intensity of fluorescence of bacterial by-products under illumination from red light. Other commercial products, such as the DIFOTI system from Electro-Optical Sciences, Irvington, NY, described in U.S. Patent 6,672,868, use transmission of light through the tooth structure for diagnostic imaging.

[0005] Diagnostic imaging methods have been developed for use with hand-held devices. For example, U.S. Patent Application Publication 2005/0003323, entitled "Diagnostic Imaging Apparatus" by Naoki Katsuda et al. describes a complex hand-held imaging apparatus suitable for medical or dental applications, using fluorescence and reflectance imaging. The '3323 Katsuda et al. disclosure shows an apparatus that receives the reflection light from the diagnostic object and/or the fluorescence of the diagnostic object with different light irradiation. However, with such an approach, any unwanted specular reflection produces false positive results in reflectance imaging. Moreover, with the various illumination embodiments disclosed, the illumination directed toward a tooth or other diagnostic object is not uniform, since the light source is in close proximity to the diagnostic object.

[0006] Cosmetic dentistry has also taken advantage of digital imaging capability to some extent, primarily for shade-matching in tooth restoration or replacement. There have been numerous solutions proposed for providing some form of automated shade matching to assist the dentist. A few examples are given in U.S. Patents No. 6,132,210 and 6,305,933, both entitled "Tooth Shade Analyzer System and Methods" both to Lehmann; and in U.S. Patent Application Publication No. 2005/0074718 entitled "Tooth Shade Scan System and Method" to Graham et al. Apparatus solutions for cosmetic imaging are outlined, for example, in International Publication No. WO2005/080929 entitled "Equipment and Method for Measuring Dental Shade" by Inglesse and in U.S. Patent No. 4,881,811 entitled "Remote Color Measurement Device" to O'Brien. Commercialized hand-held products directed to shade matching include the ShadeScan™ system from Cynovad, Montreal, CA, described in Cynovad brochure 1019 of February 2002; and the Shade-Rite™ Dental Vision System from X-Rite Inc., Grandville, MI, described in U.S. Patent 7,030,986. Notably, hand-held shade-matching systems are not designed for ease of access to any but the front teeth. Conventional shade-matching techniques can match tooth color acceptably, but may not provide enough data for providing a substitute tooth that appears real and exhibits some amount of translucency. This is largely because conventional cosmetic imaging systems are directed primarily to color matching, but provide insufficient information on tooth translucency and surface texture. For cosmetic systems that measure translucency, little or no attention is paid to uniformity of illumination. This results in an uneven distribution of light and reduces the overall accuracy of the system for measuring tooth translucency.

[0007] In spite of the growing range of imaging devices that is now available to the dental practitioner for diagnostic and cosmetic purposes, there is still room for improvement. Diagnostic imaging apparatus and shade-matching systems are still separate pieces of equipment, each system having its own requirements for system optics. To a large extent, this is the result of their different functions, affecting numerous components from illumination, light shaping, and imaging subsystems. For example, the illumination requirements for diagnostic imaging, largely using fluorescence effects, differ significantly from those of cosmetic imaging, which largely employs reflective light. Specular reflection can be undesirable for both diagnostic and cosmetic imaging, but must be compensated in different ways for each type of imaging. Image sensing, the use of polarization and spectral content, and other features further differentiate diagnostic from cosmetic systems. Thus, it would be advantageous to provide an intra-oral camera that could be used for both diagnostic and cosmetic functions.

SUMMARY OF THE INVENTION

[0008] An object of the present invention is to provide improved apparatus and methods for dental imaging. With this object in mind, the present invention provides an apparatus for obtaining an image of a tooth comprising at least one image sensor disposed along an optical axis; at least one broadband illumination apparatus for reflectance imaging; a narrow-band ultraviolet illumination apparatus for fluorescence imaging; one or more polarization elements disposed along the optical axis to eliminate specular reflection; a filter disposed along the optical axis to block narrow-band ultraviolet light; and a switch for selecting one of the operation modes of reflectance and fluorescence imaging.

[0009] An embodiment of the method of the invention is useful for obtaining images of a tooth for cosmetic imaging and comprises steps of directing light from the light source to tooth for obtaining a monochromatic image for translucency measurement; directing polarized visible light from one or more color light sources to the tooth for obtaining a polarized color reflectance image; calibrating the illumination uniformity and tooth shape; calculating a tooth shade for tooth restoration according to the images obtained; displaying a simulated image of the tooth using the calculated shade information; obtaining customer feedback on the displayed image; and sending or saving the tooth shade information.

[0010] A feature of the present invention is that it utilizes a common optical system for both diagnostic and cosmetic imaging. An advantage of the present invention is that it provides a single imaging instrument for a range of dental applications.

[0011] These and other objects, features, and advantages of the present invention will become apparent to those skilled in the art upon a reading of the following detailed description when taken in conjunction with the

drawings wherein there is shown and described an illustrative embodiment of the invention.

BRIEF DESCRIPTION OF THE DRAWINGS

[0012] While the specification concludes with claims particularly pointing out and distinctly claiming the subject matter of the present invention, it is believed that the invention will be better understood from the following description when taken in conjunction with the accompanying drawings, wherein:

Figure 1 is a schematic block diagram of an imaging apparatus for caries detection and shade matching according to one embodiment;

Figure 2 is a schematic block diagram of an imaging probe for diagnostic and cosmetic imaging;

Figures 3a to 3d show example schematic diagrams for different arrangements of components suitable for use as an illumination apparatus in embodiments of the present invention;

Figure 4 is a schematic block diagram of an imaging probe configured for diagnostic imaging;

Figure 5 shows, in a front view taken along line 5-5 of Figure 4, one arrangement for multiple illumination apparatus used in the embodiment shown in Figure 4.

Figure 6 shows an alternate embodiment of the imaging probe that employs a fold mirror for improved access to tooth surfaces;

Figure 7 shows another alternate embodiment of the diagnostic mode optical path using a polarization beamsplitter;

Figures 8a and 8b show two configurations for a color sequential illumination method;

Figures 9a and 9b show two embodiments of an attachment for capture of transmitted light;

Figure 10 shows an arrangement of probe 100 with two sensors;

Figure 11 shows an arrangement of probe 100 with three sensors;

Figure 12 shows an arrangement of probe 100 with three sensing regions;

Figure 13 shows a point-based method for measuring tooth translucency;

Figure 14 is a logic flow diagram showing how the imaging apparatus of the present invention can be operated in either diagnostic or cosmetic modes;

Figure 15 is a logic flow diagram that shows how processor logic uses the translucency and color data obtained in the process of Figure 14 to provide shade matching; and

Figure 16 shows an alternative arrangement of light sources suitable for use in the apparatus of the invention.

DETAILED DESCRIPTION OF THE INVENTION

[0013] The method and apparatus of the present invention combine both diagnostic and cosmetic functions to provide a versatile intra-oral imaging system for use by dental practitioners. As noted earlier in the background section, there are significant differences in requirements between diagnostic and cosmetic imaging, including different light source and optical system requirements, appropriate compensation for specular reflection, and different image processing. Moreover, cosmetic imaging itself is complex and can involve more than merely shade matching. In addition to matching color, accurate cosmetic imaging also requires that additional information on more subtle tooth features be obtained, including translucency, surface texture, gloss, and other characteristics.

[0014] Commonly assigned U.S. Patent Application Publication No. 2007/0099148, previously mentioned and incorporated herein by reference, describes a diagnostic imaging approach that combines both fluorescence and reflectance effects in order to provide Fluorescence Imaging with Reflectance Enhancement (FIRE). Advantageously, FIRE detection can be accurate at an earlier stage of caries infection than has been exhibited using existing fluorescence approaches that measure fluorescence alone. The apparatus and methods of the present invention further expand upon the use of FIRE imaging, as described in detail in the '9148 application, in order to provide the added advantages of cosmetic imaging when using a single intra-oral camera.

[0015] The schematic block diagram of Figure 1 shows basic components of an imaging apparatus 150 for both diagnostic and cosmetic intra-oral imaging in one embodiment. An imaging probe 100 is used to obtain images from a tooth 20, either for diagnostic or cosmetic purposes. A control logic processor 140 communicates with probe 100 to obtain the image data and provides the processed image on a display 142.

[0016] Imaging apparatus 150 can operate in either of two modes: a diagnostic mode or a cosmetic imaging mode. Subsequent embodiments give examples showing how operation in either or both modes can be obtained using a suitable configuration of probe 100 and adapting the illumination, data collection, imaging processing, and data recording and display functions accordingly.

[0017] The schematic diagram of Figure 2 shows an embodiment of imaging probe 100 that can be used for both diagnostic and cosmetic imaging purposes. Probe 100 has a handle 32 and a probe extension 40. A common optical axis O applies for both diagnostic and cosmetic image capture. Illumination for any type of image is provided from one or more of illumination apparatus 12a, 12b, 12c, or 12d, which include light sources and beam shaping optical elements. An optional attachment 30 provides illumination for translucency measurement. Probe 100 also includes a mode switch 36 which is used to select either of the operating modes: diagnostic or cos-

metic. An imaging assembly 34 contains the imaging sensor and its supporting optical components, as described subsequently.

[0018] Each of illumination apparatus 12a-12d may have both light source and beam shaping optics. Each illumination apparatus could have its own light source, or a single light source could serve for multiple illumination apparatus 12a-12d, provided with an appropriate spectral selection filter for each illumination apparatus, for example. The light source could be a solid-state light source, such as a light emitting diode (LED) or laser, or could be a broadband light source such as xenon arc lamp or other type of light source.

[0019] Figures 3a to 3d show example schematic diagrams for different arrangements of components that could be used for illumination apparatus 12a-12d in embodiments of the present invention. Each of these configurations has a light source 21. Beam-shaping optical elements 22, such as beam-shaping components 22a, 22b, or 22c condition and shape the light for uniform illumination on the tooth surface. If the beam profile from the light source is uniform enough for illumination on the tooth surface, no beam shaping optics are needed. Beam shaping component 22a of Figure 3a is a diffuser. Beam shaping component 22b of Figure 3b is a spherical or aspherical optical element. Beam shaping component 22c of Figure 3c is a light pipe. Figure 3d shows a configuration using a number of these different components in combination within an illumination apparatus. Other beam shaping components that are part of illumination apparatus 12a - 12d can include light guiding or light distributing structures such as an optical fiber or a liquid light guide, for example (not shown). The light level is typically a few milliwatts in intensity, but can be more or less, depending on the light shaping and sensing components used.

[0020] Each illumination apparatus 12a -12d can be arranged in a number of ways, as shown in detail subsequently. Light source 21 for each illumination apparatus emits light with appropriate wavelengths for each different imaging mode. In one embodiment, for example, light source 21 in illumination apparatus 12a emits broadband visible light (400nm - 700nm) for polarized reflectance imaging, or a combination from light sources with different spectrum, such as a combination of Red, Green and Blue light emitting diodes (LEDs). Light source 21 in illumination apparatus 12b emits narrow band ultraviolet (UV) light (375nm - 425nm) to excite tooth fluorescence. Light source 21 in illumination apparatus 12c emits Near-Infrared (NIR) light for translucency measurement. Light source 21 in illumination apparatus 12d emits blue light or UV for tooth surface texture measurement. The light used in the illumination apparatus 12a can be also obtained from other sources, such as a daylight simulator.

Diagnostic Imaging Mode

[0021] The schematic diagrams of Figures 4 and 5

show probe 100 as configured for diagnostic imaging. Probe 100 has a handle 32 and a probe extension 40 that is designed for insertion into the mouth for both imaging modes. Illumination apparatus 12a, with the cooperation of polarizer 42a, which is placed in front of the illumination apparatus 12a, provides uniform polarized white light illumination on the tooth surface for polarized reflectance imaging. Illumination apparatus 12b directs UV light toward tooth 20 through a bandpass filter 46 to excite fluorescence in the tooth. Bandpass filter 46 is an option and is helpful for improving spectral purity of illumination from the light source in illumination apparatus 12b.

[0022] Light reflected from tooth 20 passes through a central opening among the illumination apparatus and through an analyzer 44. One or more lenses 66 then direct reflected light through a spectral filter 56. Spectral filter 56 has a long pass that captures fluorescence data over a range of suitable wavelengths and blocks the excitation light from the light source. In order to obtain a true color reflectance image, the cut-off wavelength of the spectral filter 56 is selected so that it can block the excitation light from illumination apparatus 12b, but not block the blue portion of the light from illumination apparatus 12a. The fluorescence image that has been obtained from tooth 20 can have a relative broad spectral distribution in the visible range, with light emitted that is outside the wavelength range of the light used for excitation. The fluorescence emission is typically between about 450 nm and 600 nm, while generally peaking in the green region, roughly from around 510 nm to about 550 nm. A sensor 68 obtains the fluorescence image, typically using the green color plane. However, other ranges of the visible spectrum could also be used in other embodiments. When taking fluorescence image, analyzer 44 can be moved out of the optical axis O if necessary to increase the fluorescence signal. Referring back to Figure 1, this image data can then be transmitted back to control logic processor 140 for processing and display.

[0023] Still referring to Figures 4 and 5, polarized reflectance image data is also obtained using many of the same components. An illumination apparatus 12a directs visible light, such as a white light or other broadband light, through a polarizer 42a, and toward tooth 20. Analyzer 44, whose transmission axis is oriented orthogonally with respect to the transmission axis of polarizer 42, rejects light from specular reflection and transmits light used to form the reflectance image onto sensor 68. Filter 56 may be removed out of the optical axis O or replaced with another filter element as needed.

[0024] Sensor 68 may be any of a number of types of imaging sensing component, such as a complementary metal-oxide-semiconductor (CMOS) or charge-coupled device (CCD) sensor. Light sources used in illumination apparatus 12a and 12b can be lasers or other solid-state sources, such as combinations using one or more light emitting diodes (LEDs). Alternately, a broadband source, such as a xenon lamp having a supporting color filter for

passing the desired wavelengths, could be used.

[0025] Figure 5 shows one arrangement for multiple illumination apparatus used in the embodiment shown in Figure 4. As Figure 4 showed, probe 100 has multiple illumination apparatus 12a, 12b, 12c, and 12d. Illumination apparatus that have the same light spectrum are arranged to be symmetric to the optical axis of the imaging optics for a uniform illumination.

[0026] The imaging optics, represented as lens 66 in Figure 4, could include any suitable arrangement of optical components, with possible configurations ranging from a single lens component to a multi-element lens. Clear imaging of the tooth surface, which is not flat but can have areas that are both smoothly contoured and highly ridged, requires that imaging optics have sufficient depth of field. Preferably, for optimal resolution, the imaging optics provides an image size that is suited to the aspect ratio of sensor 68.

[0027] Camera controls are suitably adjusted for obtaining each type of diagnostic image. For example, when capturing the fluorescence image, it is necessary to make appropriate exposure adjustments for gain, shutter speed, and aperture, since this image may not be intense. When sensor 68 is a color sensor, color filtering can be performed by color filter arrays (CFA) on the camera image sensor. That is, a single exposure can capture both back-scattered reflectance and fluorescence images. In one embodiment, the reflectance image is captured in the blue color plane; simultaneously, the fluorescence image is captured in the green color plane.

[0028] Image processing by imaging apparatus 150 (Figure 1) combines the reflectance and fluorescence images in order to obtain a contrast-enhanced image showing caries regions, as is described in the '9148 Wong et al. application. Various methods can be used for processing, combining, and displaying the images obtained.

[0029] Figure 6 shows an alternate embodiment of probe 100 that employs a fold mirror 18 for improved access to tooth 20 surfaces. This fold mirror is necessary in order to access the buccal surface of the molars and the occlusal and lingual surface of all teeth. Figure 7 shows another alternate embodiment of the diagnostic mode optical path using a polarization beamsplitter 38. An illumination apparatus 14 provides light of one polarization directed through a beam shaping optical element 14a from a light source 14b, which is reflected from polarization beamsplitter 38 and directed toward tooth 20. Beam shaping optical element 14a shapes the light from an illumination apparatus 14 to provide uniform illumination on the tooth surface. Reflected light of the opposite polarization state is then transmitted through polarization beamsplitter 38 toward sensor 68. This arrangement removes specular reflected light from other scattered light, so that the returned light includes a high proportion of reflectance light from caries sites. Using the arrangement of Figure 7, illumination apparatus 14 can be selected from a number of configurations, such as a combination

of the light sources with different wavelengths or a single light source with spectrum selection filter. The light source 14b can also be outside of the handheld probe and the light delivered to the beam shaping optical element 14a through an optical fiber or other light guide such as a liquid light guide. One advantage of this embodiment is that illumination apparatus 14 can be easily changed to meet different applications. For example, illumination apparatus 14 can be changed to provide a daylight simulator for dental shade matching in cosmetic imaging mode, as is described subsequently.

Cosmetic Imaging Mode

[0030] When switched to cosmetic imaging mode, probe 100 operates under a different set of requirements. In this mode the illumination sources and optical path are suitably configured for the types of measurement that are of particular interest for cosmetic imaging. This includes the following:

- (i) Color shade measurement;
- (ii) Translucency measurement; and
- (iii) Surface texture or gloss measurement.

[0031] In embodiments of the current invention, color shade measurement can be obtained using a number of approaches. In one approach, illumination is provided from polarized Red (R), Green (G), and Blue (B) light sources, sequentially. The resulting R, G, B images are then captured in sequence. The tooth shade can be calculated from the RGB images that are obtained. In an alternate approach, a polarized white light source is used as source illumination. The color shade of the tooth is then calculated from data in RGB planes of the white light image.

[0032] In one conventional method, unpolarized light is used in tooth shade measurement. One problem with unpolarized light illumination relates to specular reflection. The light from specular reflection has the same spectrum as the illumination light source and doesn't contain color information for the tooth. Additionally, very little surface information is obtained when specular reflection predominates and saturates the sensor.

[0033] By using polarized light illumination and specular reflection removal, embodiments of the present invention overcome this limitation and obtain scattered light from the enamel and dentin. This scattered light contains the true base color of the tooth.

[0034] Referring to Figures 4 and 5, when probe 100 of the present invention is used to measure tooth color, a broadband light source in illumination apparatus 12a is turned on. The broadband light from illumination apparatus 12a passes polarizer 42a and illuminates the tooth surface. Of all the light reflected back from the tooth, only the light having orthogonal polarization passes through analyzer 44 and reaches sensor 68. Tooth shade information is calculated from the R, G, and B plane data

of sensor 68.

[0035] Because sensor and filter performance are imperfect, there is some amount of cross talk between each color plane when broadband illumination is used. An alternative solution for tooth color measurement is to obtain 3 separate images sequentially, each image separately illuminated using light of red, green, and blue spectra separately. These images can then be combined to produce more accurate tooth shade information. One disadvantage of this method is that it may require additional image processing in order to align the three different color images since they are taken at different time.

[0036] Figures 8a and 8b show two configurations for a color sequential illumination method. The first configuration of Figure 8a comprises three light sources 21 such as red, green and blue LEDs, and one beam shaping optical element 22, which can be one of beam shaping elements 22a, 22b, or 22c, previously described or some combination of these elements. These three light sources can be switched either simultaneously or sequentially in order to obtain each of the composite Red, Green, and Blue images separately. The second configuration of Figure 3b comprises a broadband light source 21, spectrum selection filter 23 and beam shaping optical element 22. While using this configuration, the spectrum selection filter 23 is rotated to change the illumination spectrum in order to obtain Red, Green and Blue images. Light source 21 and spectrum selection filter 23 of this embodiment can be built in or provided outside of probe 100. Illumination from these color sources could be directed to probe 100 by optical fiber or liquid light guide. This type of arrangement allows a wide selection of light sources, without the constraints imposed by size and weight limitations for probe 100.

[0037] The translucency of a tooth can be determined by measuring the reflectance light returned from the tooth or, alternately, the light transmitted through the tooth. The translucency can be used as a coordinate of the measurement point in one dimension of the shade space dedicated to this parameter. It can also be used for correction of at least one other coordinate of the measurement point in another dimension.

[0038] To use the reflectance light to determine tooth translucency, specular reflection must be removed either by changing the illumination angle, or by using polarized light illumination. One advantage of embodiments of the present invention using polarized light illumination relates to the light captured by the sensor and scattered in enamel and dentin. If unpolarized light is used, specular light reflected from the tooth surface and from the superficial layer of the enamel is much more pronounced than is the light returned from enamel and dentin. This can lead to inaccurate translucency data.

[0039] Theoretically, with the uniform illumination and ideal enamel, the tooth is more translucent if the light level of the polarized light, reflected from the tooth surface, and captured by the sensor 68, is lower. However, there are several factors that can affect the light level of

the polarized light captured by the sensor 68. These factors include, for example, the thickness of the enamel, the local tooth defect, fillings, and local absorption. Therefore, calibration is an important process for translucency measurement. Also, in order to determine the translucency of the tooth from reflected light, calibration is necessary to correct the illumination non-uniformity and tooth shape factor. With calibration, one or more images captured for tooth color shade measurement, as discussed in a previous paragraph, can be processed to determine the tooth translucency. In one preferred embodiment, Near-Infrared (NIR) light is used for tooth translucency measurement since the scattering is weaker inside the tooth for light with longer wavelengths. In particular, the measurements taken in infrared light can be used for the correction of one coordinate of the measurement point in a dimension corresponding to the red shades. Illumination apparatus 12c and polarizer 42c in Figures 4 and 5 provide NIR light for translucency measurement.

[0040] When transmitted light is used to determine tooth translucency, the tooth is illuminated from the side opposite the image sensor. The illumination is not necessarily polarized, since there is no specular reflection in transmission mode. Translucency is determined by the light level transmitted through the tooth. A higher light level means that the tooth is more translucent.

[0041] Referring to Figures 9a and 9b, two embodiments of attachment 30 are shown. Either embodiment can be added to imaging probe 100 in order to capture transmitted light. In both embodiments, light from illumination apparatus 12a or 12c is delivered to a light output window 31 of attachment 30 by a light guide element. The light source, such as LEDs or other solid state light source, can also be placed directly in the light output window 31. In the embodiment of Figure 9a, the light illuminates the tooth at an angle, as indicated by lines 33. In the embodiment of Figure 9b, the light illuminates the tooth directly. In both embodiments, calibration on illumination uniformity is necessary when calculating the translucency from the transmitted light.

[0042] Another parameter of the tooth capable of being used as a coordinate of the shade space, or as a correction parameter, is the tooth's surface condition. This parameter is termed the roughness parameter, or texture. The roughness parameter can be used to establish one coordinate of the measurement point in one dimension of the shade space dedicated to this parameter. This can be determined by illuminating the tooth with light, and measuring the angular distribution and intensity of the light reflected from the tooth surface. A smooth tooth surface tends to return a greater amount of specularly reflected light. Since the scattering effect is stronger for light with shorter wavelength, blue or UV light source can be generally more advantageous for tooth surface texture or roughness measurement. Since the light reflected by the tooth surface and superficial enamel layer is more relevant to surface properties of the tooth, one strategy

is to illuminate the tooth surface with polarized light, then to capture light of the same polarization state that is reflected from the tooth.

[0043] Again referring to the architecture of probe illumination shown generally in Figure 4 and more particularly in Figure 5, illumination apparatus 12d and polarizer 42d provide polarized light illumination for surface texture measurement. The light source in illumination apparatus 12d could be any light source in the spectral range from UV to NIR. In one preferred embodiment, UV or blue light is used, since the surface scatter effect is stronger. For surface roughness measurement, the orientation of polarizer 42d is orthogonal to that of other polarizers 42a and 42c in order to capture the light reflected back from the tooth surface with the same polarization as the illumination light. Polarizer 42d is not a requirement for surface roughness measurement and could be an option. Without polarizer 42d, light captured by the sensor is still polarized since there is an analyzer 44 in the imaging path. This polarized light contains both specular light and scattered light, since the illumination light is unpolarized. The analyzer 44 could be moved out of the optical axis too as needed for surface texture measurement.

[0044] As described earlier with reference to Figures 7 and 8, instead of separate light sources, beam shaping elements, and polarizers, a single broadband light source with one spectrum selection filter and one beam shaping element can also provide the needed illumination for color shade, tooth translucency, and surface roughness measurement.

[0045] Illumination uniformity is useful for determining both tooth translucency and surface roughness measurement. Any one of the illumination configurations shown in Figure 3 could generate sufficiently uniform illumination. On the other hand, tooth shape is another factor which has a significant effect on the light level received by the sensor. For example, even with the same surface quality, the light level reflected back from the tilted surface is lower than that of the surface perpendicular with the optical axis. For these reasons, calibration for both illumination uniformity and surface shape is very important in order to obtain accurate measurement on tooth translucency and surface roughness.

Alternate Embodiments

[0046] Figures 10, 11, and 12 are alternative embodiments of probe 100 using more than one sensor. There are some benefits with more than one sensor, especially for an apparatus with diagnostic and cosmetic application modes. In Figure 10, there are two sensors, 68a and 68b. A polarization beamsplitter 65 divides the light returned from the tooth into two parts having different polarizations. The light with orthogonal polarization goes to sensor 68a, while the light with the same polarization state goes to sensor 68b. A long pass filter 56 is placed in front of the sensor 68b to block the excitation light from illumination apparatus 12b. In diagnostic imaging mode, sen-

sensor 68b captures a fluorescence image and sensor 68a captures polarized white light image. In cosmetic imaging mode, the data from sensor 68b, which has the same polarization state as the illumination beam, can be used to determine the surface roughness. The data from sensor 68a is used to calculate the color shade and translucency.

[0047] The embodiment of probe 100 in Figure 11 comprises three sensors, one for each color. A beam splitter element 67 separates the beam into three spectrum bands: UV to Blue band, Green band and Red to NIR band. One type of beam splitter element 67 that can be used is an x-cube that is configured to direct light to three sensors with different spectrum bands. As in Figure 10, one long pass filter 56 is required in order to obtain fluorescence images without cross talk from the excitation light. Since there are Red, Green and Blue imaging data from three sensors separately, the calculated color shade is more accurate.

[0048] Figure 12 is yet another alternate embodiment with three sensing regions 69r, 69g, and 69b in one sensor 69. Color filter 58 is placed in front of sensor 69 so that sensing regions 69r, 69g, and 69b capture the images in RED, Green and Blue regions. Since sensing regions 69r, 69g, and 69b are in the same plane, three separate imaging lenses 66a, 66b, and 66c are necessary.

[0049] Figure 13 shows another point-based method for measuring tooth translucency and surface roughness. As shown in this figure, a number of individual points, shown as A, B, C, D and E, are illuminated with polarized light. The sensor captures the tooth surface image formed by the orthogonal polarized light reflected from these points. The method illustrated in Figure 13 works as follows: After the illumination light reaches the enamel, it scatters inside the tooth randomly and exits the tooth surface from all over the tooth surface. Even when the tooth is not illuminated over its entire surface, the sensor can still obtain the tooth image with sufficient scattered light. This image gives a particularly good characterization of tooth properties, such as tooth translucency and surface roughness. It should be emphasized that Figure 13 only presents a point illumination method. Other illumination methods, such as grid illumination and line illumination, can be applied and can offer similar advantages.

Operation of Imaging Apparatus 150

[0050] Imaging apparatus 150 is designed to obtain translucency, surface texture, and color shade measurements as well as to obtain images for dental caries detection. Figure 14 is a logic flow diagram showing how this apparatus can be operated in either mode. Initially, an operation mode selection 70 is made, such as by actuating mode switch 36. In diagnostic imaging mode, the light source in illumination apparatus 12a or 12b is turned on for tooth examination (step 72). When the operator

decides to capture the images and pushes the shutter (or otherwise enters the command to capture the image), the light sources in illumination apparatus 12a and 12b are switched on and off sequentially for sensor 68 to capture the polarized reflectance image and fluorescence image (step 73). Then the image processing software processes the images and provides the analyzed data (step 76). Software suitable for this purpose is disclosed in commonly assigned, copending U.S. Patent Application Serial No. 11/623,804, previously mentioned, the contents of which are incorporated by reference into this specification.

[0051] With the selection of cosmetic imaging mode, the light source in illumination apparatus 12a is turned on to determine the right teeth for imaging (step 78). To take images for color shade, translucency and texture measurement, the light sources in illumination apparatus 12a, 12c, and 12d (or light source 31) are turned on and off sequentially (step 80). The final step 82 is to calculate, using image analysis techniques known to those skilled in the art, the tooth color shade, translucency, and roughness from the images obtained in step 80.

[0052] The logic flow diagram of Figure 15 shows how processor logic uses the translucency and color data obtained in the process of Figure 14 to provide shade matching. After the tooth shade, translucency and surface roughness are calculated (step 82), the image processing software displays a simulated tooth to the patient for review (step 84). A patient approval step 86 then prompts the patient to approve the calculated shade, using a simulation provided on display 142 (Figure 1). When approved, the data is sent to a lab or other processing facility (step 88). If not, the image process software will modify the simulated image based on the patient's preference (step 90), and re-display the modified image to the patient for approval.

[0053] The invention has been described in detail with particular reference to certain preferred embodiments thereof, but it will be understood that variations and modifications can be effected within the scope of the invention as described above, and as noted in the appended claims, by a person of ordinary skill in the art without departing from the scope of the invention. For example, various arrangements of light sources in illumination apparatus 12a-d could be used, with various different embodiments employing a camera or other type of image sensor, such as the parallel arrays of light sources shown in Figure 16.

[0054] Thus, what is provided is a dental imaging apparatus that provides, in a single unit, diagnostic imaging for caries detection and cosmetic imaging for shade mapping.

PARTS LIST

[0055]

12, 12a, 12b, 12c, 12d. Illumination apparatus

14. illumination apparatus
 14a. Beam shaping optical element
 14b. light source
 18. Fold mirror
 20. Tooth
 21. Light source
 22. Beam shaping optical element
 22a. Diffuser
 22b. Beam shaping element
 22c. Light guide
 23. Spectrum selection filter
 30. Attachment for translucency measurement
 31. Light output window
 32. Handle
 33. Light lines
 34. Imaging assembly
 36. Mode switch
 38. Polarization beamsplitter
 40. Probe extension
 42, 42a, 42c, 42d. Polarizer
 44. Analyzer
 46. Bandpass filter
 56. Long pass spatial filter
 58. Color filter
 65. Polarization beamsplitter
 66, 66a, 66b, 66c. Lens
 67. Beamsplitter
 68, 68a, 68b, 68c. Sensor
 69. Sensor
 69r, 69g, 69b. Sensor regions
 70, 72, 73, 76, 78, 80, 82, 84, 86, 88, 90. Method steps
 100. Imaging probe
 140. Control logic processor
 142. Display
 150. Imaging apparatus
 A, B, C, D, E. illumination points
 O. Optical axis

FURTHER SUMMARY OF THE INVENTION

[0056]

1. An apparatus for obtaining images of a tooth, comprising:
 a) at least one image sensor disposed along an optical axis;
 b) at least one broadband illumination apparatus for reflectance imaging;
 c) a narrow-band ultraviolet illumination apparatus for fluorescence imaging;
 d) one or more polarization elements disposed along the optical axis to eliminate specular reflection;
 e) a filter disposed along the optical axis to block narrow-band ultraviolet light; and
 f) a switch for selecting one of the operation

modes of diagnostic imaging using reflectance and fluorescence imaging, and cosmetic imaging using reflectance imaging.

2. The apparatus of 1, wherein cosmetic imaging further uses light transmission through the tooth.

3. The apparatus of 1 further comprising an attachment for illuminating the occlusal or lingual surface to obtain an image from the transmitted light.

4. The apparatus of 1 wherein the broadband illumination apparatus comprises at least one light source with the spectrum from 400nm to 700nm.

5. The apparatus of 1 wherein the broadband illumination apparatus further comprises one or more beam shaping elements.

6. The apparatus of 1 wherein the narrow-band ultraviolet illumination apparatus comprises at least one narrow-band ultraviolet light source with the spectral range of 375nm to 425nm.

7. The apparatus of 1 wherein the narrow-band ultraviolet illumination apparatus further comprises a bandpass filter to clean the spectrum of the narrow-band ultraviolet light source.

8. The apparatus of 1 wherein the polarization element is a polarization beamsplitter.

9. The apparatus of 1 wherein the polarization element is a plate polarizer.

10. The apparatus of 1 wherein there are two image sensors, further comprising a polarization beamsplitter to separate the light with different polarization states to two sensors.

11. The apparatus of 1 wherein there are two image sensors, further comprising at least one dichroic mirror to separate the light with different spectral ranges to at least two sensors.

12. A method for obtaining images of a tooth for cosmetic imaging, comprising:

(a) directing light from a light source to a tooth for obtaining a monochromatic image for translucency measurement;
 (b) directing polarized visible light from one or more color light sources to the tooth for obtaining a polarized color reflectance image;
 (c) calibrating the illumination uniformity and tooth shape;
 (d) calculating a tooth shade for tooth restoration according to the images obtained;

- (e) displaying a simulated image of the tooth using the calculated shade information;
- (f) obtaining customer feedback on the displayed image; and
- (g) sending or saving the tooth shade information. 5

13. The method of 12 further comprising a step to illuminate the tooth with deep blue or UV light for obtaining reflectance image for tooth surface texture measurement. 10

14. The method of 12 wherein the light for obtaining monochromatic image is delivered to occlusal or lingual surface of the tooth. 15

15. The method of 12 wherein calculating the tooth shade for tooth restoration includes the tooth shade, tooth translucency and tooth surface texture. 20

Claims

1. A method for obtaining images of a tooth for cosmetic imaging, comprising: 25
 - (a) directing light from a light source to a tooth for obtaining a monochromatic image for translucency measurement;
 - (b) directing polarized visible light from one or more color light sources to the tooth for obtaining a polarized color reflectance image; 30
 - (c) calibrating the illumination uniformity and tooth shape;
 - (d) calculating a tooth shade for tooth restoration according to the images obtained; 35
 - (e) displaying a simulated image of the tooth using the calculated shade information;
 - (f) obtaining customer feedback on the displayed image; and 40
 - (g) sending or saving the tooth shade information.
2. The method of claim 1 further comprising a step to illuminate the tooth with deep blue or UV light for obtaining reflectance image for tooth surface texture measurement. 45
3. The method of claim 1 wherein the light for obtaining monochromatic image is delivered to occlusal or lingual surface of the tooth. 50
4. The method of claim 1 wherein calculating the tooth shade for tooth restoration includes the tooth shade, tooth translucency and tooth surface texture. 55

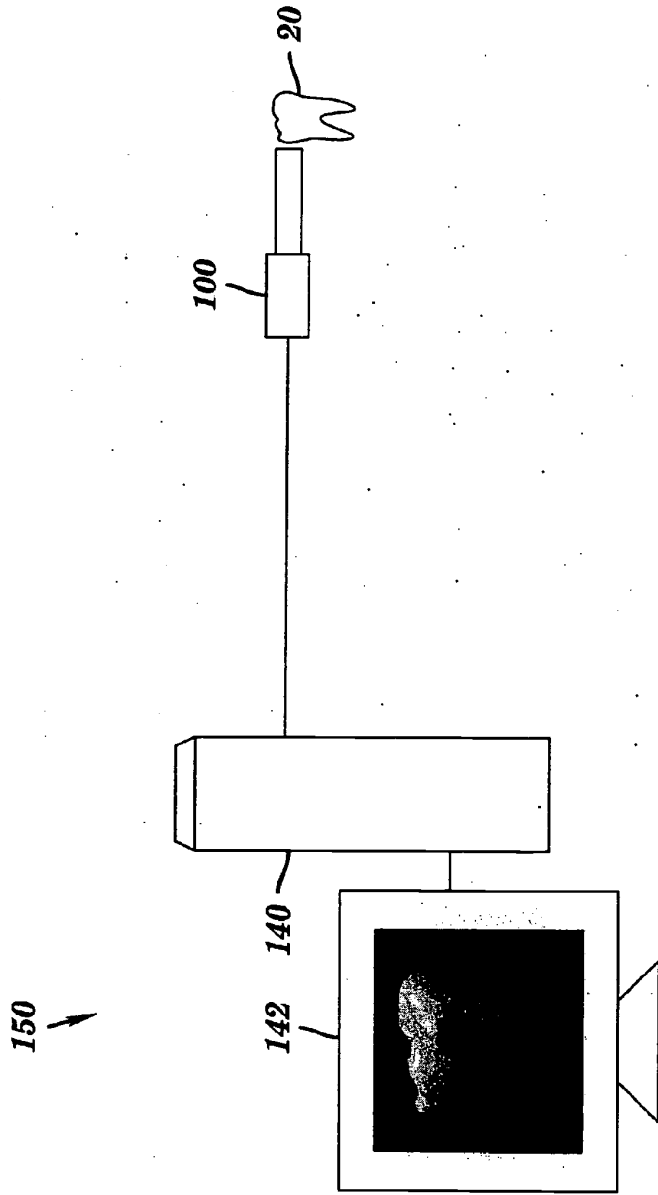

FIG. 1

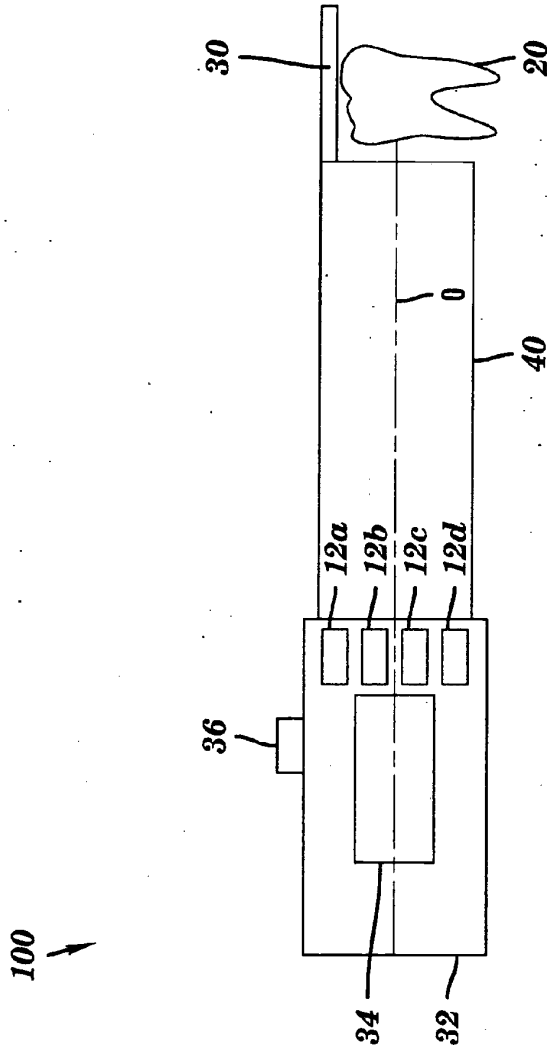

FIG. 2

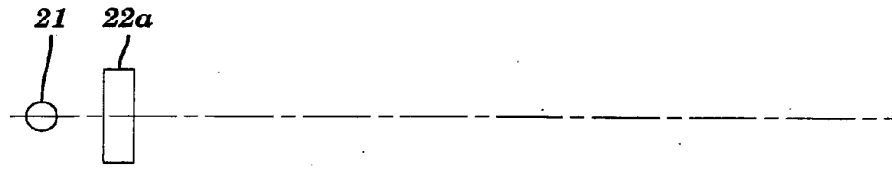

FIG. 3a

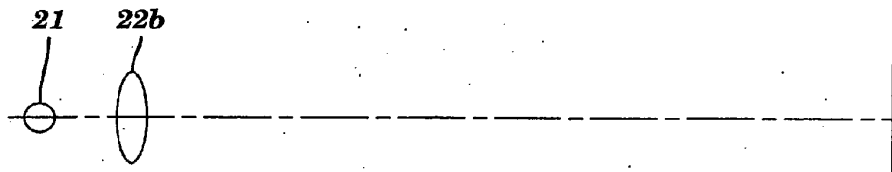

FIG. 3b

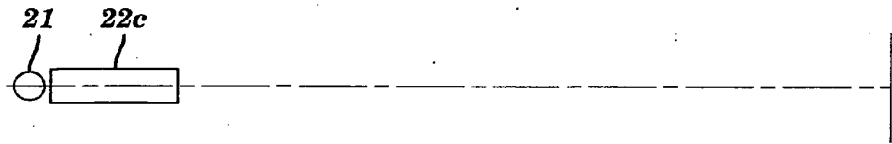

FIG. 3c

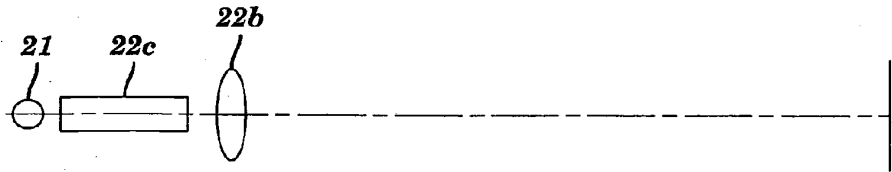

FIG. 3d

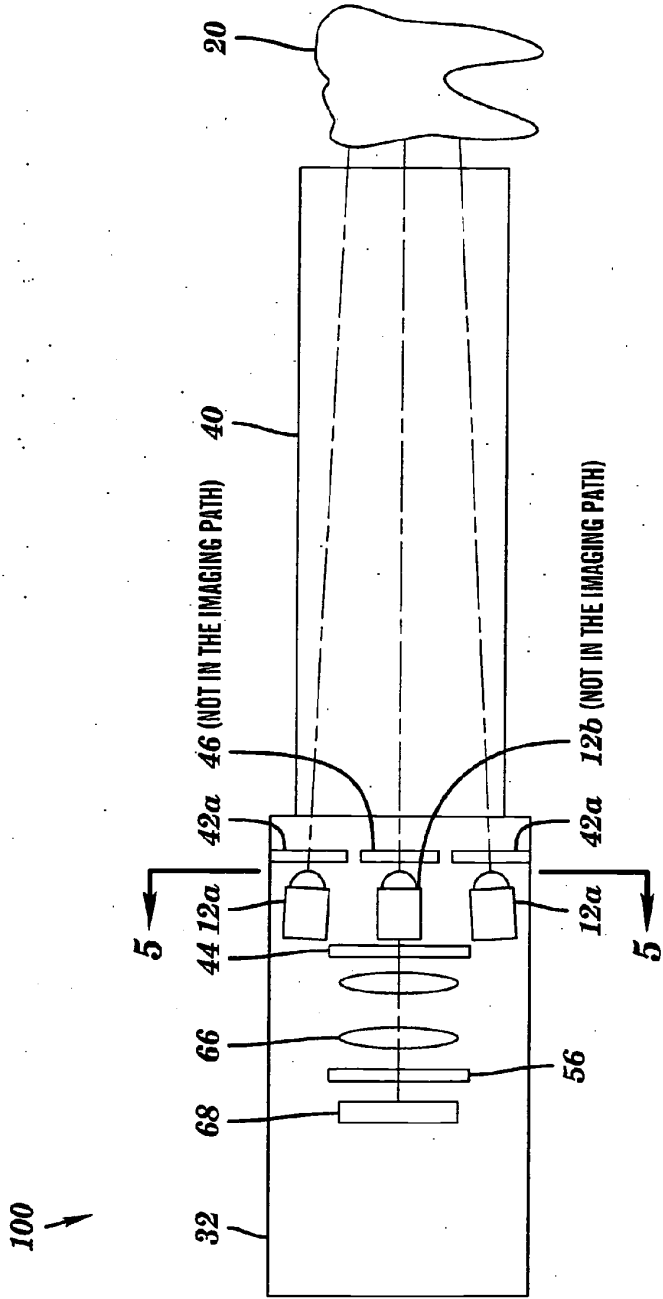

FIG. 4

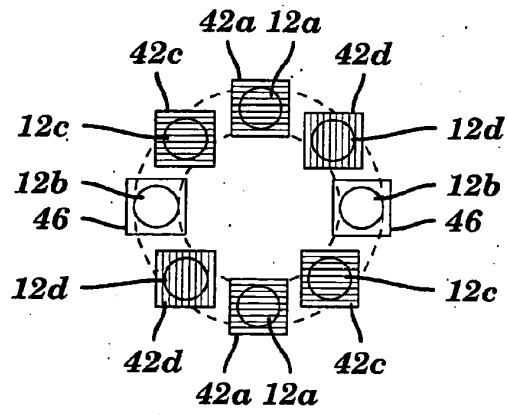

FIG. 5

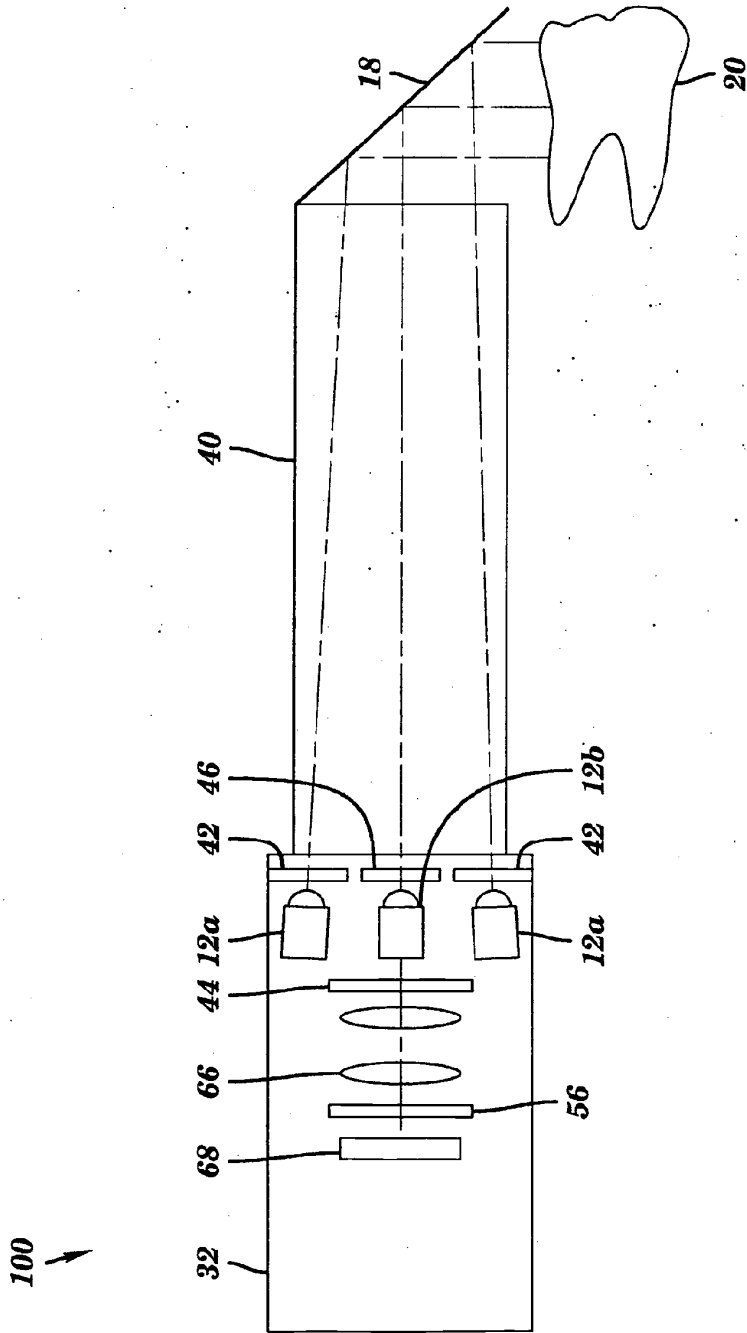

FIG. 6

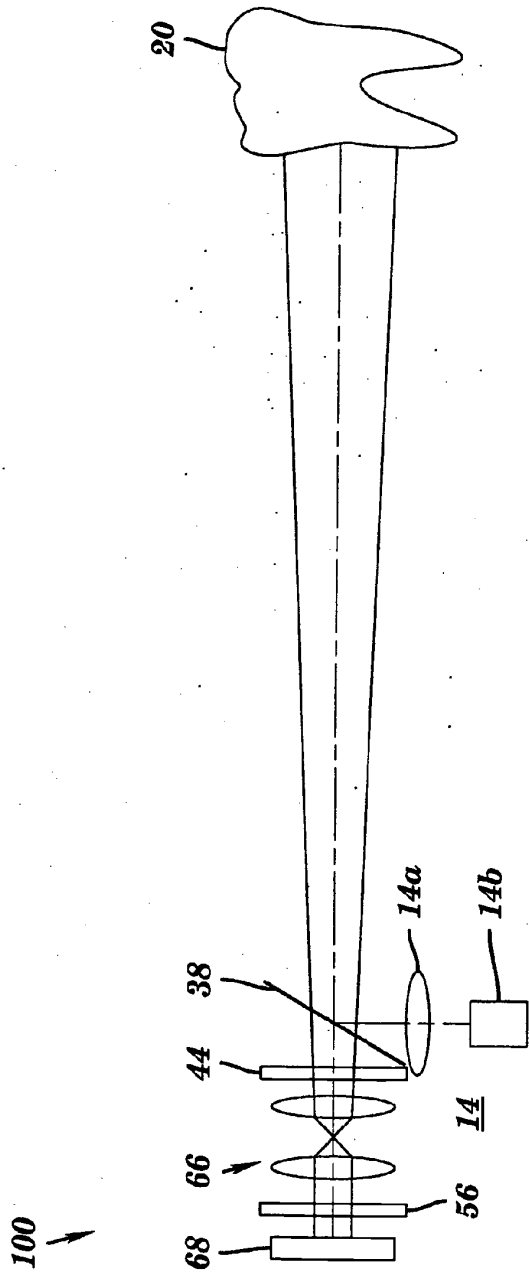

FIG. 7

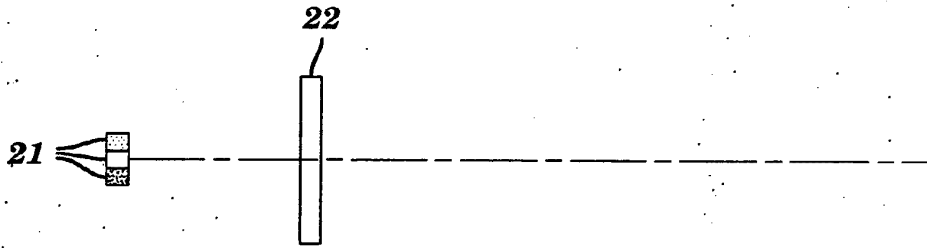

FIG. 8a

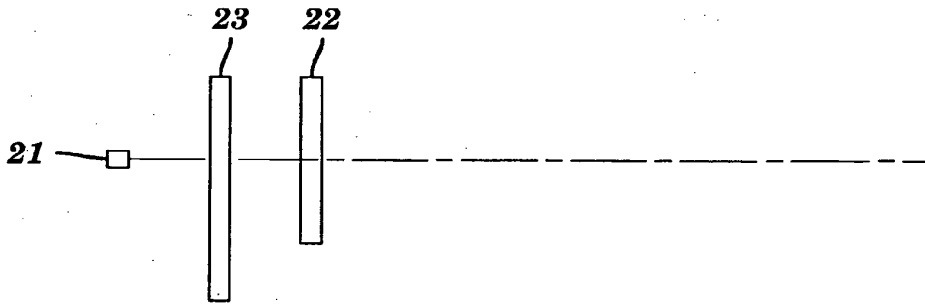

FIG. 8b

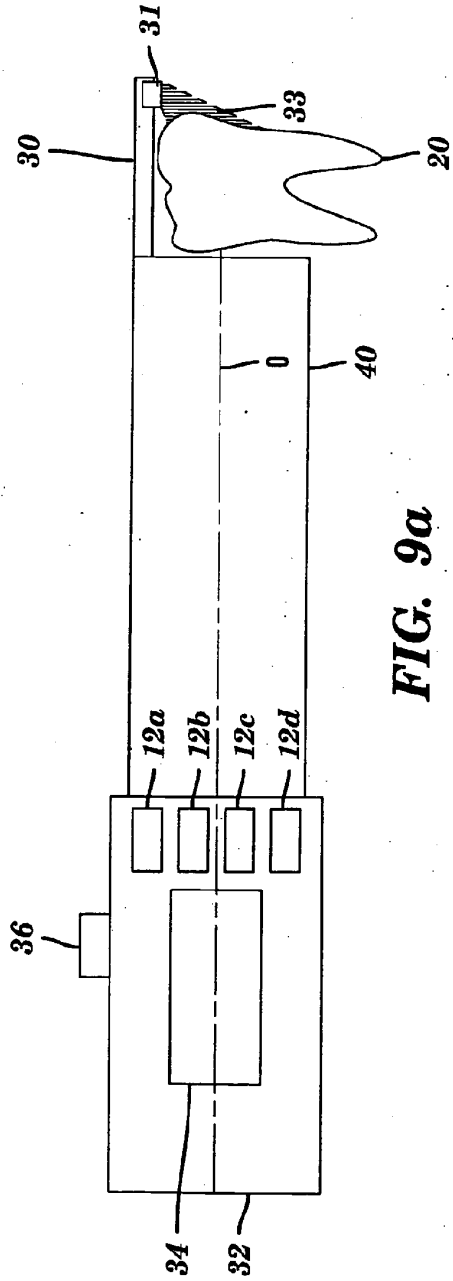

FIG. 9a

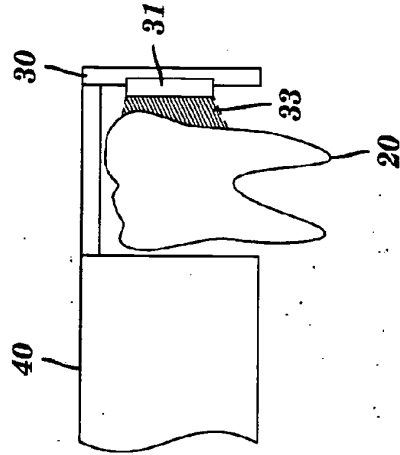

FIG. 9b

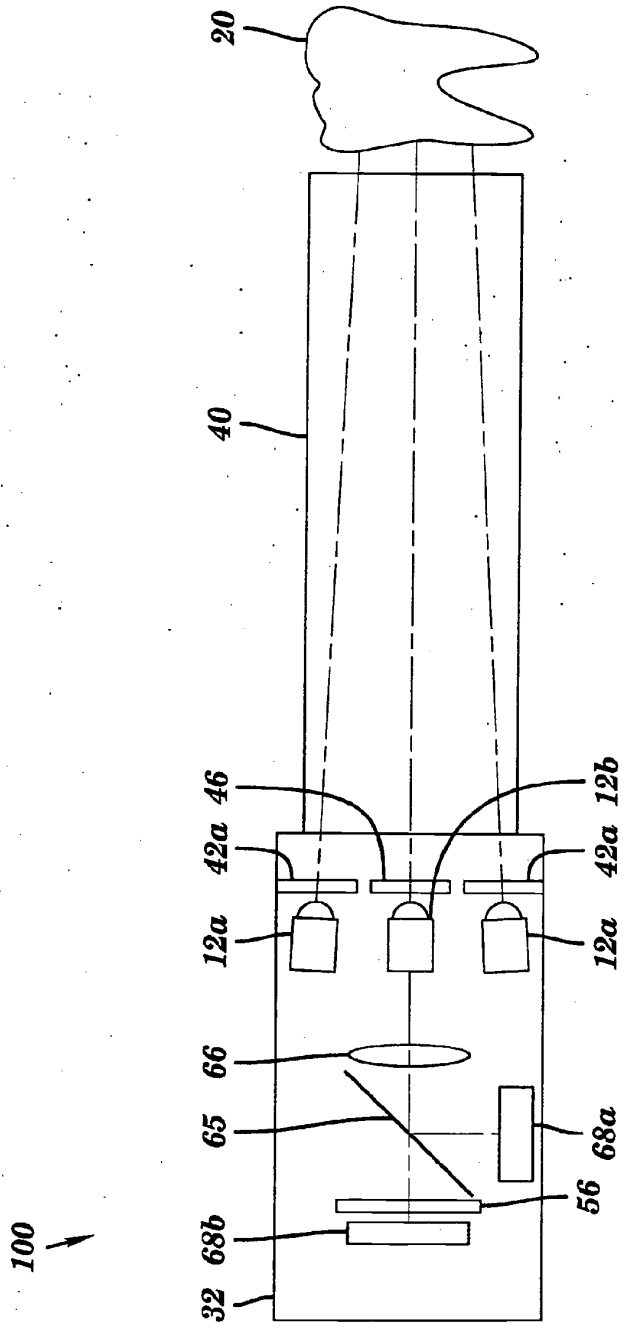

FIG. 10

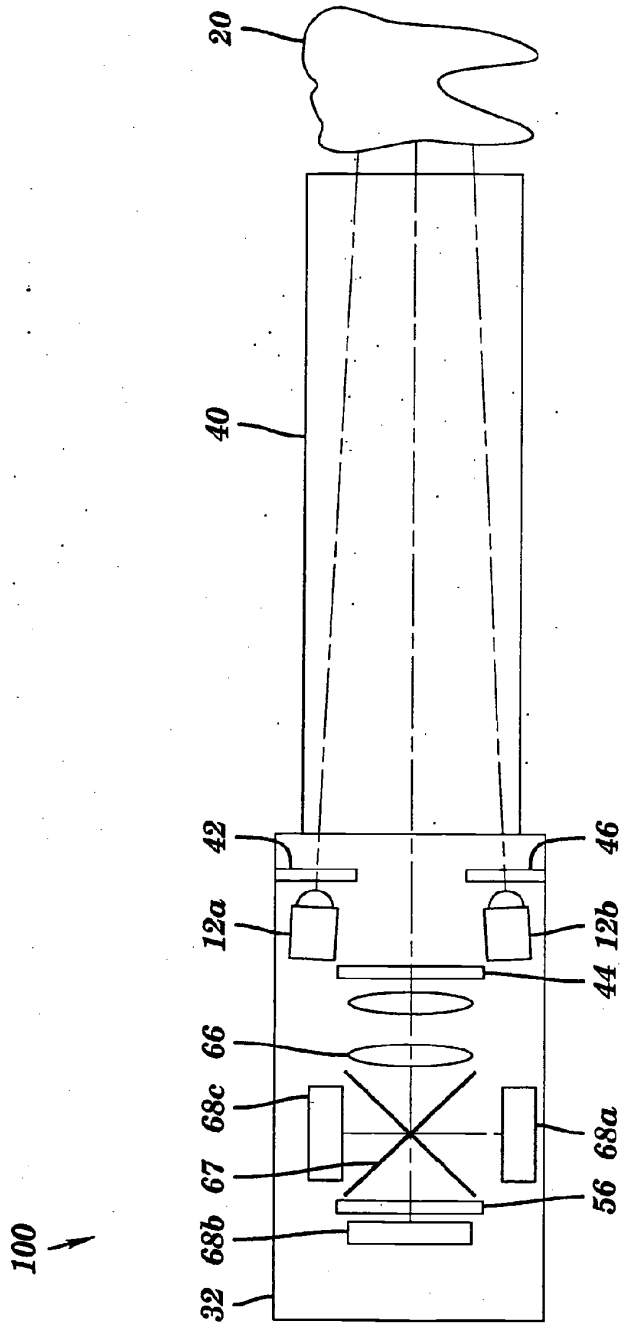

FIG. 11

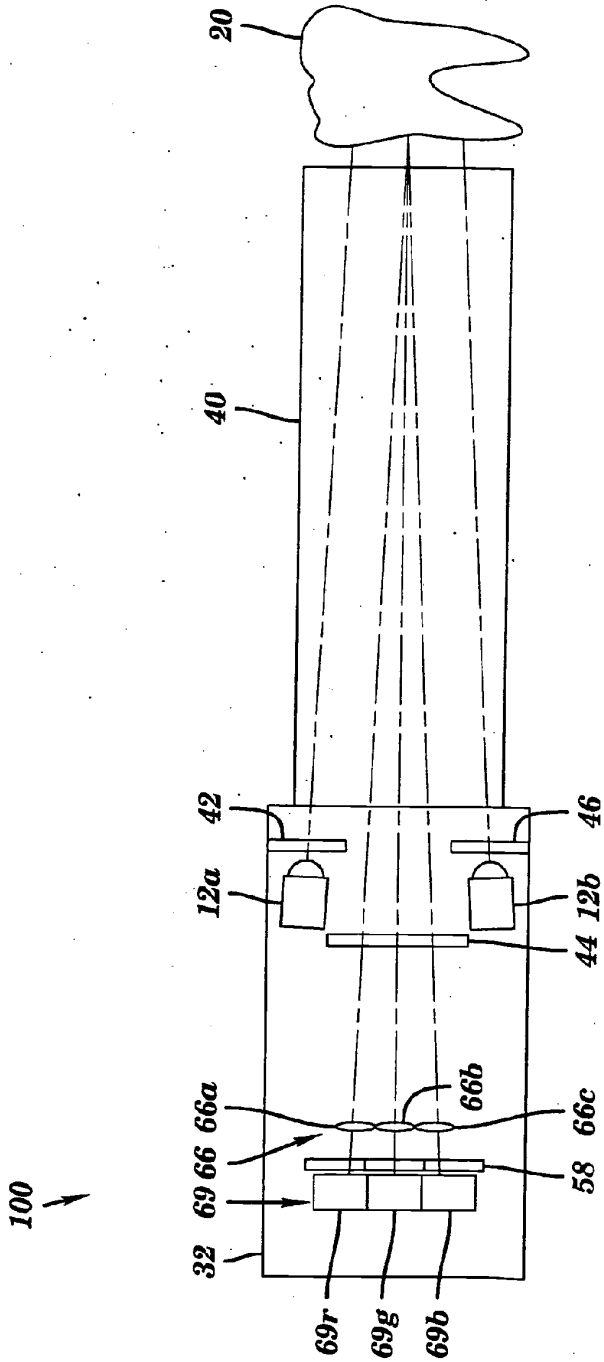

FIG. 12

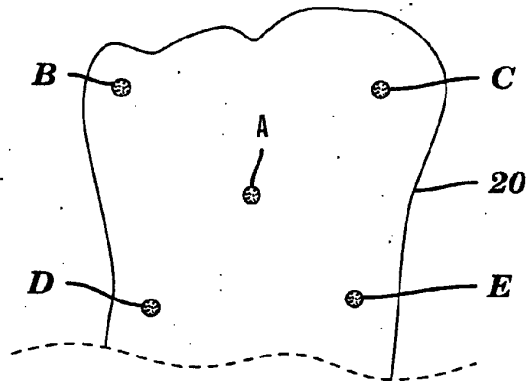

FIG. 13

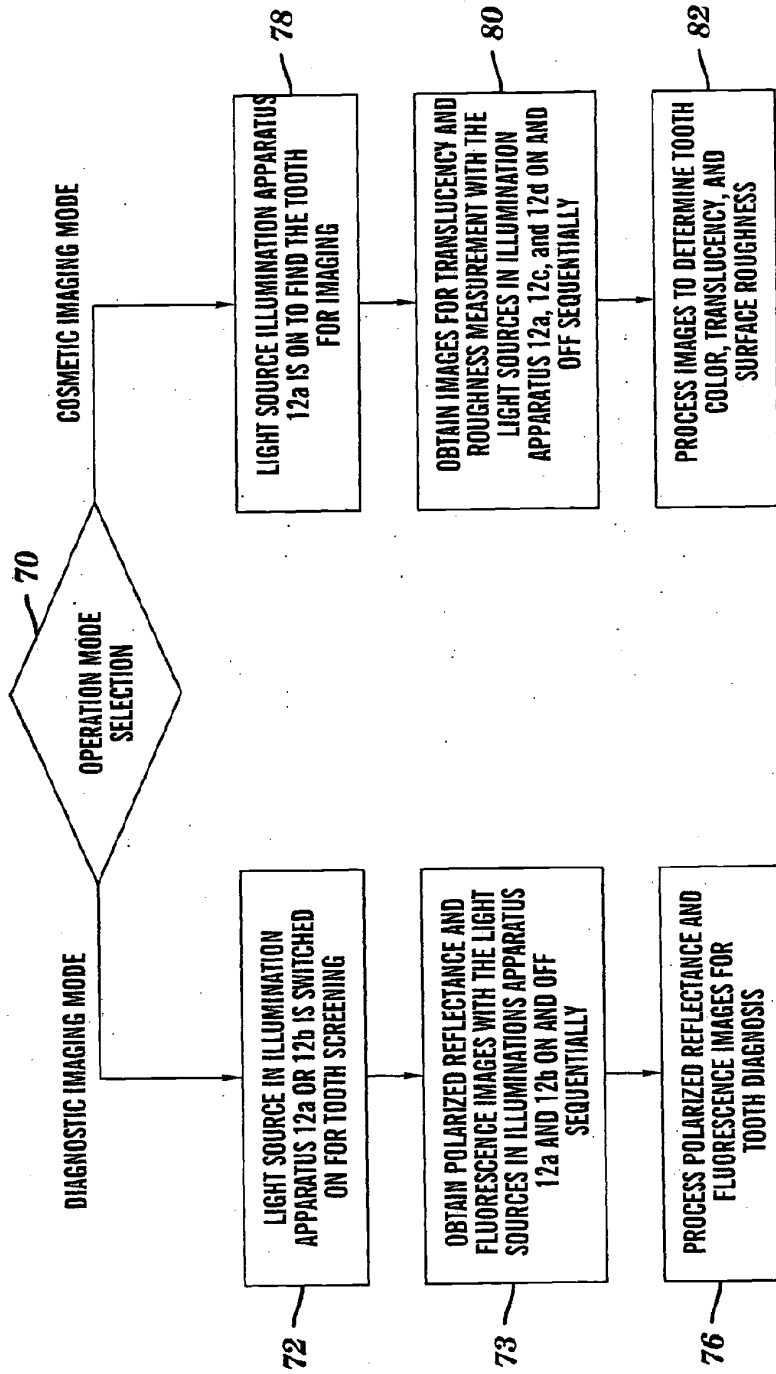

FIG. 14

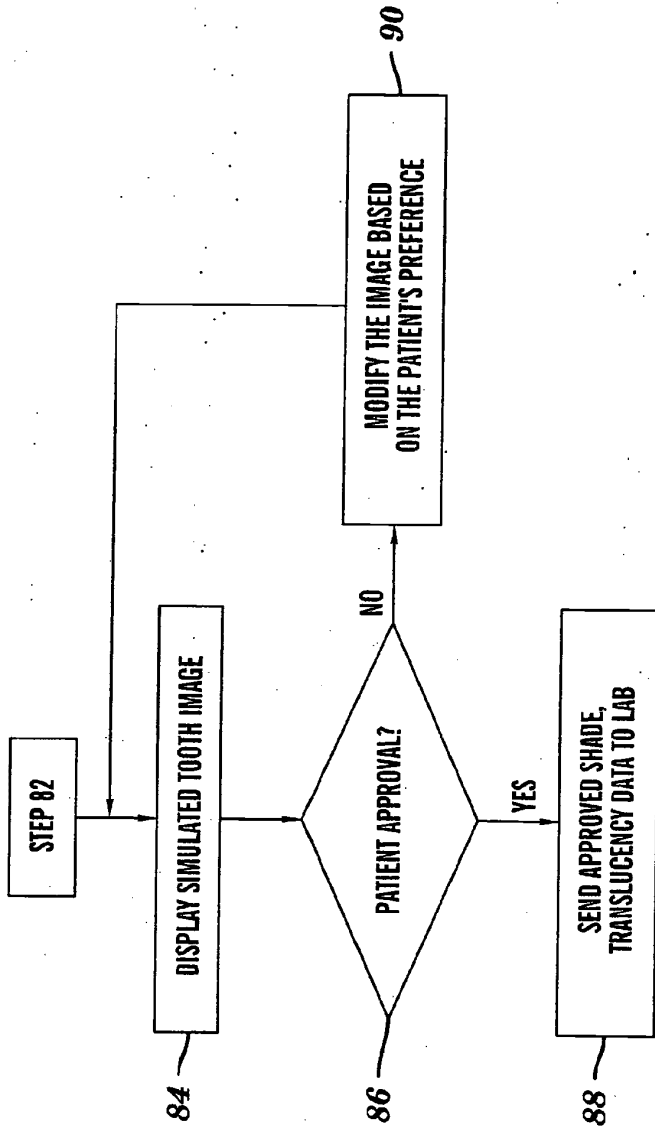

FIG. 15

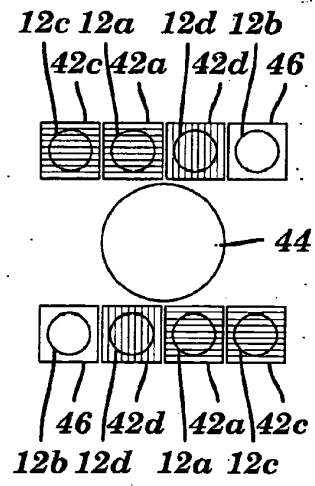

FIG. 16

EP 2 241 248 A2

REFERENCES CITED IN THE DESCRIPTION

This list of references cited by the applicant is for the reader's convenience only. It does not form part of the European patent document. Even though great care has been taken in compiling the references, errors or omissions cannot be excluded and the EPO disclaims all liability in this regard.

Patent documents cited in the description

- US 4290433 A [0002]
- US 6231338 B [0002] [0004]
- US 4479499 A [0003]
- US 20070099148 A [0003] [0014]
- US 6024562 A [0004]
- US 6672868 B [0004]
- US 20050003323 A [0005]
- US 6132210 A [0006]
- US 6305933 A [0006]
- US 20050074718 A [0006]
- WO 2005080929 A [0006]
- US 4881811 A [0006]
- US 7030986 B [0006]
- US 623804 A [0050]

(12) INTERNATIONAL APPLICATION PUBLISHED UNDER THE PATENT COOPERATION TREATY (PCT)

(19) World Intellectual Property
Organization

International Bureau

(43) International Publication Date
17 January 2013 (17.01.2013)



(10) International Publication Number
WO 2013/008097 A1

(51) International Patent Classification:

A61B 1/24 (2006.01) A61B 1/05 (2006.01)
A61B 5/107 (2006.01) A61B 1/06 (2006.01)
A61B 1/00 (2006.01) A61C 9/00 (2006.01)
A61B 5/06 (2006.01)

(21) International Application Number:

PCT/IB2012/001777

(22) International Filing Date:

9 July 2012 (09.07.2012)

(25) Filing Language:

English

(26) Publication Language:

English

(30) Priority Data:

11 56201 8 July 2011 (08.07.2011) FR

(72) Inventors; and

(71) Applicants : DURET, François [FR/FR]; Château de Tarailhan, F-11560 Fleury D'aude (FR). QUERBES, Olivier [FR/FR]; 6 Avenue de l'Occitanie, F-31520 Ramonville Saint-Agne (FR). QUERBES-DURET, Véronique [FR/FR]; 6, Avenue de l'Occitanie, F-31520 Ramonville Saint-Agne (FR).

(74) Agent: RHEIN, Alain; Cabinet Brev&Sud, 55, Avenue Clément ADER, F-34170 Castelnau Le Lez (FR).

(81) Designated States (unless otherwise indicated, for every kind of national protection available):

AE, AG, AL, AM, AO, AT, AU, AZ, BA, BB, BG, BH, BR, BW, BY, BZ, CA, CH, CL, CN, CO, CR, CU, CZ, DE, DK, DM, DO, DZ, EC, EE, EG, ES, FI, GB, GD, GE, GH, GM, GT, HN, HR, HU, ID, IL, IN, IS, JP, KE, KG, KM, KN, KP, KR, KZ, LA, LC, LK, LR, LS, LT, LU, LY, MA, MD, ME, MG, MK, MN, MW, MX, MY, MZ, NA, NG, NI, NO, NZ, OM, PE, PG, PH, PL, PT, QA, RO, RS, RU, RW, SC, SD, SE, SG, SK, SL, SM, ST, SV, SY, TH, TJ, TM, TN, TR, TT, TZ, UA, UG, US, UZ, VC, VN, ZA, ZM, ZW.

(84) Designated States (unless otherwise indicated, for every kind of regional protection available):

ARIPO (BW, GH, GM, KE, LR, LS, MW, MZ, NA, RW, SD, SL, SZ, TZ, UG, ZM, ZW), Eurasian (AM, AZ, BY, KG, KZ, RU, TJ, TM), European (AL, AT, BE, BG, CH, CY, CZ, DE, DK, EE, ES, FI, FR, GB, GR, HR, HU, IE, IS, IT, LT, LU, LV, MC, MK, MT, NL, NO, PL, PT, RO, RS, SE, SI, SK, SM, TR), OAPI (BF, BJ, CF, CG, CI, CM, GA, GN, GQ, GW, ML, MR, NE, SN, TD, TG).

Published:

- with international search report (Art. 21(3))
- before the expiration of the time limit for amending the claims and to be republished in the event of receipt of amendments (Rule 48.2(h))

WO 2013/008097 A1

(54) Title: THREE-DIMENSIONAL MEASURING DEVICE USED IN THE DENTAL FIELD

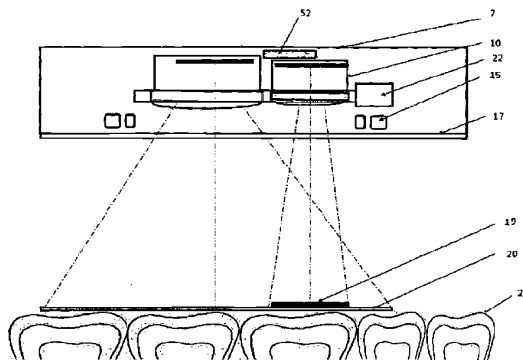

Figure 4

(57) Abstract: Three-dimensional measuring device used in the dental field and aimed at measuring in the absence of projection of active or structured light, comprising image-capturing means and data-processing means for images. The image-capturing means (38, 39) consist of means designed capable of permitting to capture simultaneously, or almost simultaneously, at least two images, one of which is totally or partially included in the other one, said included image describing a narrower field than that of the other one, and having a higher accuracy than that of the other one.

THREE-DIMENSIONAL MEASURING DEVICE USED IN THE DENTAL FIELD

The present invention relates to a new secure three-dimensional measuring device through contactless high-precision and wide-field optical color impression without structured active light projection, especially for dentistry.

The present invention ensures the structural integrity of the human body and an accuracy in the range of one micron. It is applicable namely in the medical and dental fields for intra-oral picture recordings and assistance in diagnosis.

It includes:

1) a miniaturized three-dimensional reading system using no active or structured light projection for measuring the dimensions of the object, consisting of

a) one or more CCD- or CMOS-type electronic sensors and its associated optical system,

b) eventually one LED or OLED lighting of one or several wavelengths permitting to diagnose eventual pathologies at the surface of the teeth or the gums,

c) one or more accelerometers/gyros/3D-magnetometers for assisting, limiting, even replacing one or several sensors.

2) a central unit for converting analogue/digital data and management data,

3) associated software permitting 3D spatial analysis almost in real time, temporal analysis for analyzing the movements of the measured objects, colorimetric analysis for analyzing the color of these objects in direct correlation and in real time with the surfaces measured in 3D providing assistance for the diagnosis

through reflection, global or selective penetration of the carefully selected LED/OLED light radiation,

4) an IHM communication "hardware" and "software" set (screen, keyboard, modem ...).

5 This invention permits to solve the fundamental problems the systems for recording optical 3D impressions are facing. It provides real-color and real-time information for the dentistry. It measures the object without projecting any structured active light with an accuracy of at least 10-15 μm at a field depth of
10 at least 15 mm and a surface of at least 20 x 30 mm on the teeth located within 10 mm of the front lens of the camera.

There exist a large variety of methods for recording optical impressions in the mouth or on a model for making prostheses or a diagnosis. By the term "optical impression" first introduced
15 in 1973 by the inventor of this technology, Francois Duret, in his thesis for the second cycle (DDS) under the title "Optical Impression" No. 273, the 3D measuring and diagnostic analysis of the oral and medical environment by contactless optical means, in substitution of the traditional impression methods with paste
20 or probing.

In the dental field the works by Dr. Duret, described i.a. in a number of articles and in his patents dd. May 9, 1980 (FR 80.10967 or US 4,663,720 and 4,742,464), April 14, 1982 (BE 0,091,876 - US 4,611,288), November 30, 1982 (EP 0110797, US
25 5,092,022), March 27, 1984 (FR 84.05173), February 13, 1987 (FR 87.02339 or US 4,952,149) or also June 26, 1992 (FR 92.08128 or PCT WO 94/00074) have been echoed by many authors since the early 1980s, as we will see in the various technologies, which can be summarized as follows.

30 1) The techniques using the projection of active or structured light.

The simplest method used by these systems consists in projecting on the object structured light, which may be a dot, a line, even a full grid. This light will scan the object and is followed by one or several CCD or CMOS 2D cameras positioned at an angle ranging between 3° and 10° with respect to the axis of the light projection. These techniques have been widely known for several decades and are very well described in the article by G Hausler and Col. « light sectioning with large depth and high resolution » in Appl. Opt. 27 (1988). They have been the object of numerous developments and are used in particular by the desktop scanners in dental laboratories.

A more sophisticated method consists in projecting onto the teeth a structured active light in the form of a varying-pitch grid. The most common technique for this kind of fringe projection has been described for the first time by M. Altschuler and Col., under the title "Numerical stereo camera" SPIE vol 283 3-D (1981) Machine perception, which publication has been echoed by other authors such as M Halicua and Col. « Automated phase measuring profilometry of 3D diffuse objects » in Appl.Opt. 23 (1984). It consists in projecting a series of varying-pitch grids. The grid with the wider pitch serves for providing general information and the global position of the lines in z, the finest line for refining the accuracy of reading.

All these works and inventions have led to many embodiments and to more than twenty commercially available systems (F.Duret, the dental floss No. 63, May 2011, "the great adventure of CAD/CAM at IDS in Cologne" 14-26). We will cite for example the systems using a spot scanning system (Cera from Cera system, GNI from GC and Nikon), a line scanning system (Titan from DCS, Ekton from Straumann), a varying-pitch frame scanning system (Cercom from Degudent, Digident from Hint-Els, Everest from Kavo, Lavascan from 3M, Zeno from Wielan or Wol-ceram from Wol-dent).

These systems cannot be used in the mouth because they are too slow (1s to 1mn). The slightest movement by the patient or the operator impedes the full reading and the necessary correlation of pictures for transforming a 2D cross-sectional display into a 3D image. Furthermore, there is no information between the lines, which requires a series of readings in different directions, which further increases the reading time significantly (up to 4 minutes per tooth for the complete readings).

Finally, more recently, in order to more easily determine the spatial position of the projected fringes, the chromatic profilometry technique has been provided, which uses the varying-color fringes. It has been described as profilometry by Cohen Sabban, BV F 2758076 and is the object of a marketing under the name Pro50 (Cynovad - Canada).

In order to meet the intra-oral reading requirements, faster systems has been provided. The first one has been marketed in France in 1985 under the name of Duret system (Vienne - France) and used the system of profilometric phase in conical projection as described in the patents (FR 82.06707 or US 4,611,288), (FR 82.20349 or US 5,092,022) and (FR 87.02339 or US 4,952,149). This technique has been adopted with great success by Moermann and Brandestini in their Patents 4,575,805 and 4,837,732 or in their books dealing with the issue as "Die Cerec Computer Reconstruction" in 1989, "CAD/CIM in Aesthetic Dentistry" in 1996 or also "State of the art of CAD/CAM restoration" in 2006. This method has been improved gradually as we can see in the patent by Jones, T.N. of 1999 (U.S. 6.409.504).

This is an active and structured light projection technique in the form of a frame projected onto the teeth according to parallel or conical radiation with a slight phase shift (generally $n/2$) and performing a series of 2D picture acquisitions (in 100 ms), the third dimension can be found

provided the patient and the camera are perfectly still while recording the successive pictures, which remains difficult during a clinical action, the more since the electro-optical organs of the camera are mobile.

5 Other slightly different systems, but which use structured active projection in the mouth, have been provided:

The simplest one is the "OralMetrix", which consists in projecting one single type of grid onto the surface of the teeth, as described in FR 84.05173). This is therefore an active
10 triangulation associated with one single projection of structured light. One single camera reads the deformation of the grid and, by comparison with a stored grid, derives the distance z from it, the acquisition of six pictures per second associated with a 2D view of a deformed grid makes the system inaccurate
15 and unstable during the picture recording.

The second system is the "directScan" from the company Hint-Els (USA). It combines the fringe projection and the phase correlation. This method takes place in two steps: projection of two series of orthogonal grids with different pitches, one after
20 the other, then correlation of the pictures obtained depending of the position of the dots at the level of the pixels of the CCDs. This is an improvement of the profilometric phase, but the processing time is about 200 ms, which makes its use very difficult in the mouth. The measures are often erroneous.

25 The third system provided is the iTeo system from the company Cadent (US.0109559) based on the principle of the "parallel confocal image" where many 50 μm laser dots are projected at different field depths. This scanning of the target area has the advantage of having one single axis of image recording and re-
30 recording of images, but takes about 300 ms. The apparatus must therefore not move during the recording of images. In addition, since this technology is complex, the iTero system is

particularly voluminous, which limits the recording of images in the depth of the mouth.

The fourth system has been provided by G. Hausler (US 2010.0303341). Several structured light grids of different orientations are projected onto the arch. This permits to find the third dimension immediately through correlation between the first deformed grid and the next ones. This method permits to record only one image, but has the disadvantage of being capable of measuring only the dots of the deformed grid and not all the dots of the object itself.

In these methods based on active and structured light projection, we obtain several 2D images permitting to reconstruct the analyzed object in 3D. These methods are the more accurate as the projected light is fine and calibrated and as the moving organs are stable over time. Unfortunately, none of them measures the object itself, but only the deformation of the projected light, which limits the number of measured dots and can hide important areas for the exact reconstruction of the analyzed 3D surface.

Furthermore, it very often requires the object to be coated with a white layer referred to as coating, or to use special plasters when a model is measured. Indeed, the specular reflection of the teeth is very sensitive and responds in a varying way to the structured light projected depending on its own color.

This also has a major drawback as regards the accuracy of the measurement. The structured active light, because of its power, penetrates into the surface layers of the tooth, adding inaccuracy to the exact determination of the outer surface.

The calibration of these devices is complex and the mounting is always very complex and expensive.

Finally, since the angle of projection is often different from the angle of recovery of the image, the shadow effects can lead to the presence of uncoded shadow areas, which requires many manipulations. It should also be noted that we have no
5 information between the lines.

Some systems have tried to limit the projection of structured light without removing it. To this end, they have associated a very small projected portion with a conventional 2D stereoscopic vision. One uses two identical cameras and projects a line or a
10 target having a varying shape onto the object and moves the whole while scanning the surface of the object. The two 2D cameras form a conventional stereoscopic unit, both information of which are correlated thanks to the projected target visible in the two pictures. This system is marketed by means of the T-
15 scan 3 sensor from Steinbichler Opt. (Neubeuern - Germany) or by Uneo (Toulouse - France). These methods, which have the same drawbacks as the methods described above, could never be applied to dentistry, because they in addition lack precision and, in particular, they require the projected target to always be
20 displayed, which remains difficult on highly specular or uniform surfaces as in the case of the teeth.

2) The techniques, which do not use active or structured light projection.

The first proposal to use a stereoscopic intra-oral system was
25 made by D. Rekow (J. of Dent. Practice Administration ; 4 (2) 52-55 (1984). In this system, it is necessary to make several acquisitions, with a reference fixed on the teeth, then to read these frames by means of a Kodak Eikonix device. This ancestral method, well known under the name of stereoscopic, has proved
30 inaccurate and time-consuming for its implementation. This method was recently proposed again by Denzen Cao US 2009.0227875 (Sandy - USA) and by Steinbichler Opt. EP 2,166,303 (Neubeuern - Germany) without any improvement over the system by Rekow, in

particular the resolution of the field depth, the determination of the reference dots and the accuracy, which is a crucial problem during the recording of intra-oral pictures corresponding to a close stereoscopic, has not been addressed.

5 Such a system cannot be carried out in the mouth if we want to achieve an accuracy of 20 μm at a field depth of 20 mm with the object placed within 5 mm of the front lens.

The same remarks can be made for the systems using the technique referred to as "3D from motion" described, for example by C.

10 Tomasi and Col. « Shape and motion from image streams under Orthography : a factorization Method » dans Int. J. of Computer Vision 9 (2) 1992. This system no longer uses active light, as seen before, but only a passive illumination of the area measured by a conventional stereoscopic vision with two cameras

15 having the same resolution. Unfortunately, under conventional circumstances as described by the authors, the correlations of pictures without projected target and the abundance of areas without coding make the use of this system impossible on the teeth. It does not solve the problems evoked by Rekow.

20 This is the reason why recently the system by Active Wavefront Sampling (AWS), based on the Biris system, marketed by 3M with his Lava Cos camera has been introduced on the market in 2008 (Rohaly and Co. US Patent 7,372,642). This system uses a single view scanning, thanks to a rotatory disk, a very small portion

25 of the object. The diameter of the position of the view in the focal plane and the mechanical variation of the focal length with respect to the optical axis of the mounting permits to know the spatial position of the small area measured at a small-field depth. Unfortunately, the system is complex and expensive for

30 its implementation and the very small scanning area requires the operator to slowly move over all the areas to be measured.

Whether they are laboratory systems or intra-oral cameras, including the one we developed, all these systems do not provide

the required qualities to have a quality information in order to make prostheses or diagnoses. A more thorough analysis shows that these cameras have several very important drawbacks, in the very principle of the methods used. These drawbacks are
5 unavoidable, because they are related to the choice of these methods.

a) All these systems, whether in the mouth, on the skin or in the laboratory (on model) use the surface scanning by mechanical, optical or electro-optical means. Although this
10 scanning of fringes or frames is very fast, the fact remains that it requires a movement in the camera itself, which movement can cause blurry areas or parasitic movements, which often lead to the rejection of part of the pictures.

b) This scanning significantly limits the already considerably
15 reduced field depth in a macroscopic picture (of a few cubic centimeters).

c) the dots of the surface of the object are not measured, but the deformation of a light projection on the surface of this object is measured. This first feature requires developers to
20 cover the teeth with a white layer referred to as "coating", which degrades, in principle, the actual measurement of the object. This is in fact often expressed both as inaccuracy and inconvenience in the use of cameras in the mouth (Beuttell, J Int.J.Computerized Dent. 1998 1:35-39).

25 Besides, this layer is often mandatory if we do not want to have any penetration, thus inaccuracy, in measuring the exact position of the tooth surface, crystalline organ per excellence where a sufficient signal-to-noise ratio is required.

d) This has led some manufacturers to use radiation, making the
30 tooth "opaque" as do the blue or UV rays. This is why the present inventor proposed in 1985, presented to the ADF, the use

of an argon laser. This can be restrictive for the user, even dangerous, for the patient.

e) even more, not measuring the object, but the deformation of the projected light, either a dot, a line, a frame of a varying shape or a phase of this light, removes all possibilities of
5 having a perfect match in real time between the color, the color shade of the object and its measurement. The only color that we can have in real time is the color of the projected light.

f) There is no immediate solution allowing the clinician to
10 continue his surgical procedure if a component fails, which is crucial during a clinical procedure.

g) the transition from 3D reading to 2D color reading, when it is used for diagnosis, is completely impossible in dentistry, because we will recover only a monochromatic image representing
15 the light of the fringes.

h) finally, the techniques of analysis by profilometry or scanning require recording multiple pictures of the same spot in order to be able to extract the third dimension. This results into a risk of distortion of the data between the first picture
20 and the last pictures, leading to large errors in correlation and accuracy. The "movement" has always been an enemy of this type of technology.

Finally, if it is possible to measure a tooth, in most cases a measurement of the projected light is carried out and not a
25 measurement of the object itself. In the case in which we do not use projected light, we must use complex and expensive defocussing systems. This explains why the proposed cost is particularly high. As for the only stereoscopic systems that have been provided for decades, they have nothing innovative and
30 are therefore inaccurate, time-consuming to handle, complex and very expensive to be implemented.

No simple and above all secure solution has been found to meet the tooth/camera proximity, fast carrying out, required accuracy, the measurement of the actual color and field depth on a quite large surface.

5 The object of the present invention is to solve the
aforementioned drawbacks by providing a new and very secure
stereoscopic method for intra-oral reading combining a very
fast, even instantaneous dynamic 3D reading, a measuring at a
10 field depth corresponding to the intended application and the
availability almost in real time of a real 3D or 2D color
display, all this leading to a very accurate digitalizing, a
data storage and transfer without using structured active light
or addition of a "coating" covering the teeth.

15 The three-dimensional measuring device used in the dental field
according to the invention is aimed at measuring in the absence
of active or structured light projection, it comprises means for
capturing images as well as data-processing means for said
images, and it is characterized in that said image-capturing
20 means are comprised of means designed capable of permitting to
simultaneously, or nearly simultaneously, capture at least two
images, one of which is fully or partially included in the other
one, said included image describing a field that is narrower
than that of the other one, and its accuracy is greater than
that of the other one.

25 This invention solves the problems set forth by providing an
adaptable, inexpensive solution usable in all dental and medical
offices, but also as hand-held instrument in dental-prosthesis
laboratories, in a simplified and patient-friendly form.

In particular, it solves the many problems mentioned above:

30 1) Through a new and original organization of the
traditional dental stereoscopy, we limit the problem of
the blind spots between the two picture recordings

corresponding to the difference between the optical axes, which is crucial for an object close to the front lenses of the mounting, as teeth in the mouth always are.

- 5 2) By using an original software arrangement, in case of failure of one of the sensors during the clinical procedure, it is possible to obtain a stereoscopic picture by means of one single sensor, which solution is simple, inexpensive and little bulky in the mouth.
- 10 3) By eventually adding a 3D accelerometer/gyroscope/magnetometer, it is possible to accelerate and facilitate the correlation of the pictures with each other, especially in the event of failure of one of the sensors.
- 15 4) By choosing different focal lines, it is possible to solve the problems of accuracy and speed of clinical optical recording of an impression in the mouth. This also permits to combine or separate a general, less accurate recording on a wide field and a fast and accurate recording on a narrower field depending on the clinical need.
- 20 5) By choosing new lenses, in particular the liquid lenses, it is possible to eliminate the complex mechanical adjusting equipment, which ensures a measuring at an effective field depth in dentistry on objects very close to the measuring system because of the very small intra-oral space.
- 25 6) By not using measurements of deformation of structured active light, we work directly on the actual surface and in color of the body images. This permits for example to manually or automatically select certain parts of the human body, for example to identify the teeth and gums separately.
- 30

This also permits:

- Not to be compelled to cover the measured object with the "coating", which is unaccurate and tedious
- 5 - To have no penetration of measure-vector light inside the teeth, thanks to the abandonment of active structured light projection.
- To use the color of the read areas, in order to facilitate the matching of homologous dots. which is crucial in the mouth where the surfaces remain regular and uniform.
- 10 - To make highly effective and to reduce the reading time for measuring a complex surface (full arch) or the movements of these surfaces (upper arches with respect to lower arches).
- 15 - To enable self-calibration, eliminating any adjustment over time.
- To avoid any blur effect due to "movement" during the recording of pictures.
- 20 7) For the implemented means, the device is simple as to its manufacture, which makes it particularly resistant.

This also permits:

- 25 - to significantly reduce the manufacturing cost, hence the sale price, in particular from the democratization of the electronic components used, such as CCDs, CMOS or LEDs,
- to permit a reduced power supply, which can be provided by a USB-compatible connection with all types of computers or just a battery power-supply,

- 5 - to have CMOS or CCD sensors in a predetermined, immutable and fixed spatial position with respect to each other during manufacture, avoiding the need to know the movements of the object or cameras (with respect to each other), reducing the problem of disparity to a simple problem of density correlation in the scatter diagram.

- 10 - Being able to pass from a 3D image, spatial analysis, to a 2D image, planar analysis, useful for common diagnostics in dentistry without using software manipulations.

- To have the 3D display on standard 3D screens, which is not the case without complex processing of the present intra-oral systems.

15 The present invention relates to a new three-dimensional and temporal measuring device by means of optical color impressions in the mouth ensuring its structural integrity, namely applicable in the dental field for intra-oral recording of pictures, but also ensuring in these areas an assistance for
20 dental diagnosis.

 In accordance with the present "hardware" mounting there is provided a "software" method that meets the requirements of fastness and accuracy necessary for the specialist in dentistry and permitting to limit the stereoscopic vision to one or two
25 sensors.

 It is comprised of:

 An miniaturized original stereoscopic system comprised of at least two sensors, of which:

- 1) one views a wide average-precision field and the other one a narrower field with higher accuracy fully or partially included in the previous field.

5 The wide field permitting a sufficiently large general recording of images in order to avoid a long and tedious scanning of the mouth for the practitioner.

10 Since some areas are particularly strategic and require higher precision, a narrow field is included in the wide field, which permits to detect specific information where this is necessary, without being obliged to scan the entire mouth. This also permits to better define certain important homologous spots for the correlations between pictures.

15 It also permits the "software" to operate almost in real time, as this partial or full inclusion of the small field in the large field permits to very quickly find the position of the specific and highly localized area in a wider space.

20 It is obvious that these sensors can be multiplied when one wants to measure larger clinical areas, both at the level of the large field and at the level of the small field.

- 2) The optical systems associated with the sensors have different focal lengths, in order to permit two different levels of precision. The images received by the sensors, such as for example the CCDs or CMOS included in the head of the camera, are therefore a general image with an average accuracy, for example in the range of 20 μm and a complementary image with more information and a higher accuracy (5 to 10 μm) fully or partially included in the wide field. It is therefore unnecessary to scan the

entire mouth to have accurate information required for by only less than 5% of the total area.

3) The advantage of this system is to facilitate the correlation of the two fields, since they are very similar, but also to limit the number of sensors without having to use clock or pulsed reading systems. Indeed, the approximation of the two fields shows that a single wide-field sensor or two sensors can be used without any complex electronic system. It also permits to avoid the use of light- or image-returning mirrors, which are always fragile and very voluminous in the mouth.

4) The fields are read by one or several electronic sensors, which can be of the color or monochromatic CMOS or CCD type generating the information necessary for calculating the color 3D or grayscale information. These sensors thus perform a measuring of the real-time color or black and white intensities. The measured color will thus be the actual color of the teeth and gums.

This is very important, because it permits i.a.:

- a. to automatically separate the teeth from the gums in the images.
- b. to identify some important colors for the CAD/CAM software
- c. to measure the color of the tooth on a three-dimensional surface.

5) This information is treated either by way of a video, in order to allow the operator and his assistants to follow in real time the movements of the camera in the mouth or, after an analog-to-digital conversion in a digital way that permits to have an almost real-time color 3D

reconstruction and to be able of taking advantage of the dental CAD/CAM software processing, or a dual video and digital processing providing the operator with all the available information.

5 This will also allow the operator, as we will describe at the level of the "software", to know and come back to the areas that have been insufficiently measured in real time.

10 6) The optical system reading the scene has two different focal lengths. The advantage of this device is to be able to have:

15 a. a focal length that does not require high precision, and to be able to have a unique fixed focal length without adjusting system. It is indeed optically possible to have a 20 x 30 x 15 mm field at 10 mm from the lens for an accuracy of 20-25 μ .

20 b. a high-precision focal length (5 to 10 μ m), but the field depth of which is included in the previous one. The scanning in z will thus always be simple and known a priori. The scanning in z (field depth) will thus be limited to some 5 to 10 different levels.

25 c. a high-precision focal length and variable zoom permitting to freely choose and increase the desired accuracy.

30 7) In order to facilitate the reading in the mouth by the practitioner, without any need of monitoring his screen, it is foreseen that the device includes means for projecting at least one circle of colored light surrounding the included image field, and/or the field of the other image:

- a. Eventually and preferably, the existence of a mark, for example a red circle, projected onto the scene in the picture indicating where the exact reading is located in the reading of the wide field.
- 5 b. Eventually and preferably, the existence of a mark, such as a blue circle, projected onto the scene in the picture indicating where the edge of the wide field is located.
- 8) In order to avoid unpleasant and dangerous interruptions in the clinical reading in the mouth, a 3D accelerometer/gyroscope/magnetometer is eventually and advantageously added, in order to facilitate the correlation of the pictures, even to compensate for a possible failure of one of the sensors. This device, placed in the vicinity of the sensors, provides general and continuous information on the spatial position of the camera.
- 10
- 15
- This also permits, thanks to the "software" introduced, which is an inseparable part of the invention, to work with only one single sensor, the wide field or the narrow field, depending on the clinical needs, since some actions require a general study as in orthodontics, or a very accurate detection as for the localized unitary reconstitution.
- 20
- 9) While measuring on gypsum generally benefits of a good lighting, this is not true for readings in the mouth. Eventually and advantageously, the addition is provided of a passive and unstructured lighting by LEDs of one or several wavelengths permitting to measure specular or Lambertian smooth surfaces without deposition of coating on the surface of the mouth.
- 25
- 30

Not using structured light also avoids the operator from turning off his professional lighting, which greatly facilitates his clinical work.

- 5 10) The information detected at the same time or with an extremely short shift avoids any movement causing redhibitory blur due to the movement of the operator or the patient.
- 10 11) In order to limit the blur phenomena, an anti-blur hardware system, or a "flash LED" system with a very fast pulse of the unstructured LED lighting or also a software that can be of type: anti-blur system in photographic cameras, is eventually added.
- 12) With the present invention is associated, for processing and displaying the data from the sensors:
- 15 a. a central management and analog/digital conversion unit without the slightest need for mechanical, optical or electro-optical scanning, structured-light projection permitting to calculate the 3 spatial dimensions and eventually the fourth
- 20 dimension corresponding to the times of the movements of the measured objects.
- b. original software permitting the use of a single sensor permitting a 3D detection almost in real time, in order to compensate for a possible failure
- 25 of one of the sensors or to limit the volume of the camera.
- c. a data transmission via cable, telephone or wireless.

d. a complementary processing, dialog/display with the operator, data transmission and storage hardware system.

An original software system including:

- 5 1) A real-time 3D reconstruction diagram starting from two 2D-image streams from both cameras,
- 2) A real-time 3D reconstruction diagram starting from a 2D-image stream from a single camera and an acceleration data flow from the accelerometer
- 10 3) An algorithm for finding dots of interest on the three algorithms for searching an optical trace (projection of the same 3D dot on several different cameras) by calculating dots of interest and matching through the images
- 15 4) An algorithm for real-time automatic sequencing of the stream of images into spatially coherent subsequences
- 5) An algorithm for estimating in parallel the camera positions in space and the coordinates of the 3D dots thanks to the optical traces
- 20 6) An algorithm for 3D interpolating the scatter diagram
- 7) An algorithm for polygonizing 3D scatter diagrams and calculating the texture
- 8) An algorithm for scaling the 3D reconstruction
- 9) Two algorithms for enhancing the spatial accuracy

25 Global organization of the algorithm:

The image stream proceeding from the cameras is processed in real time so as to produce a first 3D reconstruction displayable

by the user as he moves the system in the vicinity of the object. The real-time 3D global reconstruction scheme and the organization of the data vary depending on the availability of the two cameras.

5 Each newly acquired picture is first of all processed by a algorithm for searching for an optical trace. Starting from the correspondences, a sequencing algorithm then updates the sequencing of the video stream for a better temporal performance. A parallel estimation algorithm can then permits,
10 thanks to the optical traces

a) to find the positions of the cameras in the space at the time of acquisition

b) to generate the 3D scatter diagram projecting on the optical traces.

15 The generated scatter diagram is then interpolated, in order to obtain a denser diagram, and an implicit interpolation function is calculated. Thanks to this function, a textured polygonization of the surface to be reconstructed can be obtained. In this step, it is also possible to calculate quality
20 indices of the final scatter diagram. Some of them or some areas can thus be labeled as invalid.

The textured surface is then displayed on the screen, eventually with adapted annotations to indicate the areas, which are still invalid.

25 The surface generated in real time is a representation without spatial dimension representing a scale factor near the reconstructed area. This scale factor is calculated by an algorithm when the acquisition is complete.

30 Finally, the final 3D model can have its accuracy enhanced by an algorithm, so as to have the most accurate possible

reconstruction. This algorithm re-calculates a 3D scatter diagram taking into consideration all the acquired pictures. This diagram is then interpolated by the algorithm. Finally, a "space carving" algorithm reconstructs the global 3D model.

5 There is thus provided a device universal as to its field of application, meeting numerous requests in terms of cost, accuracy and diagnostic imaging in dentistry and medicine.

This system can for example be applied, in an evolutionary form, to any 3D acquisition requiring good accuracy including any
10 human body surface, the acquisition of data related to the architecture and requiring high precision, or the industrial production processes. It is thus possible to scan the object measured with the single or multiple sensor, to move the object in front of the sensor(s) or to move both, sensor and object.

15 We remind that the elements permitting this measurement are made in real time and with a different accuracy, which permits to improve the reading of certain areas thanks to the narrow-field camera, while facilitating, thanks to the wide-field camera, a fast correlation with other captured images.

20 Other objects and advantages of the present invention will become clear from the following description, which refers to an embodiment of the method, given by way of an indicative and non-restrictive example. The understanding of this description will be facilitated when referring to the attached drawings, in
25 which:

- Figure 1a is an overall representation of the prototype made, including the camera, the connectors, the computer (here a laptop) and eventually a casing containing the processing cards.
- 30 - Figure 1b is a diagram showing the detail of the configuration of the invention.

- Figure 2 shows a view of the prototype made, highlighting the very small dimensions of the camera, thanks to the technique chosen and permitting its introduction into the mouth.
- 5 - Figure 3 shows a longitudinal cross-sectional view of the camera (1) including the image acquisition system (optical system and CCD or CMOS sensors) located in the head, in direct views (3a and 3b).
- 10 - Figure 4 shows a frontal cross-sectional view of the head of the camera (1) according to the configuration we have just seen in drawings and 2 and denoting the covering of the wide and narrow reading area.
- Figure 5 shows the global volume analyzed by the wide-field camera and the small-field camera.
- 15 - Figure 6 shows the different levels of field depth provided by the use of variable focal length or the liquid lens analyzed by the wide-field camera and the small-field camera.
- 20 - Figure 7 shows the illustration of the pictures obtained by the wide-field camera and the small-field camera and 3D modeling obtained.
- 25 - Figures 8a, 8b and 8c show the automatic determination by software of the homologous dots on a plaster model (8a), in the mouth (8b) and the resulting scatter diagram (8c).
- Figures 9a and 9b represent the arrangement of the LEDs in passive lighting (9a) and the target projected onto the teeth (9b) permitting the practitioner to know the area scanned by the high-precision camera.

- Figures 10a, 10b and 10c represent a view obtained with white light (10a), blue light (10b) and composite blue and white light (10c).
- 5 - Figure 11 shows the aperture in the head of the camera permitting the jet of air, in order to remove saliva or blood and the protective heating glass avoiding the presence of moisture during the recording of an optical impression in the mouth.
- 10 - Figure 12 shows the general diagram of the software part, from the integration of the acquired images to the final 3D reconstruction to scale.
- Figures 13a, 13b and 13c represent three algorithms for using the acquired images in real time in the case in which two cameras are used simultaneously.
- 15 - Figure 14 shows the two possible reconstruction strategies when one single camera is used.
- Figure 15 shows an exemplary calculation of an optical trace by "tracking" of the dots of interest.
- 20 - Figure 16 shows the simplified steps of the algorithm for real-time 3D reconstruction.
- Figure 17 shows the organization of the algorithm for enhancing the accuracy.

As shown in Figure 1, the present invention, presented in the form of a prototype, in the form of a schematic design photo in the following figures, relates to a measuring and/or diagnosis
25 device that will find a particular interest in the fields of dentistry.

As shown in photo 1a, this device includes a camera with focal length (1) using the technology described in the invention, a

connection (2) between the camera (1) and the cable (3) for supplying and transferring data, the connection (4) between the cable and the computer (5) being of the USB type and the casing (6), which can be placed in between for adding a driving card for the processor of the camera and/or processing the image if they are not placed in the camera or in the computer.

This same camera can use a wireless WiFi-type connection for transmitting images or data proceeding from the images, and a charger system for charging rechargeable batteries for the power to to supplied to the camera.

The electronic part, which can be entirely included in the body of the camera (9-12) or shared between the camera, the casing (6) and the computer (5). It includes an electronic system located behind or near the sensors, ensuring the management of the latter, but also of the LEDs illuminating the impression recording area. This electronic system also includes:

- a central management unit that can collect, store and order the data of the sensors in a language understandable by a universal PC. It will eventually also be capable of converting data having analog values into digital values if this function is not transferred to the remote PC. Not having to manage a system for projecting masks or fringes significantly reduces the central unit to its bare minimum: the management of a stereoscopic color picture camera.

- a LED control card, under the control of the central unit and/or software of the PC, capable of triggering preferably a particular LED depending on the programs being implemented. Indeed, the LEDs will be controlled alternately or together, or according to a varying order depending on the program being implemented. The function is in the form of a simple order, but it is good to mention it.

- a standard power-supply card capable of operating on USB or on battery power (e.g. AC/DC). Depending on whether we have a free system (without wire connection) or a wired system, the power supply will remain light, taking into consideration the low power consumption of the components being implemented. Our camera will thus be the first one that can have a wireless connection.

- eventually, a miniaturized memory card eventually included in the camera, permitting to store the pictures and to transfer them to the computer using a transportable medium without needing a USB connection or a wireless communication.

A standard laptop (5), netbook or desktop PC containing the management and program and data processing software can be added to the unit when everything is not included in the camera or/ and the intermediate casing (6). It is capable of reproducing the information in a 2D or 3D form visible on the screen, but also to send the measures to more or less remote centers (internet, Wifi, Ethernet ...) in a standard form similar to any CAD/CAM system (STL..) or in a specific form, by means of language translation software. In this computer, before having a miniaturized computing unit, will be installed the 3D restitution and camera control software.

Thus, the connection between the camera and the computer can be wired or wireless.

According to the invention, the wireline connection (3) is preferably via a self-powered USB connection (4) with a specific port (2) at the side of the camera (1). This specific connection (2) is designed so that it is adaptable to any camera shape and design.

Likewise, and according to the invention, the connection can be wireless, for example in Wifi mode, and this is not restrictive. In this case, the antenna will be included in the camera or

connected instead of the specific connection (2). Likewise, on the computer (5) or the intermediate casing (6), an antenna for sending and receiving data corresponding to the commands given by the program located in the camera, in the computer (5) or the
5 intermediate casing (6) will be inserted into the USB connection. This arrangement will permit fast, friendly and easy communication, irrespective of the configurations of the medical, dental offices or dental prosthesis laboratories.

10 In the same way and still according to the invention, the unit formed by the processing cards, the CPU and the display will be installed in the intermediate casing (6) so that the unit according to the invention can be integrated into a professional piece of furniture, such as the unit of the dentists or the work-bench of the dental technicians.

15 According to the invention, the computer (5) will be of a standard type with an incorporated or separate screen, such as a PC or the like (Mac ...). This computer will use standard cards specifically programmed for controlling the camera or specific control cards, which will be placed on the bus.

20 In the event the computer could not be equipped or when it is previously present in the dental-care unit, an intermediate casing (6) will be positioned between the camera and the computer in order to compensate for this lack. Similarly and for the same function, this casing will be positioned downstream of
25 the computer and the USB connection (4) of the connection will be connected directly to the USB port of the computer, without any intermediate part. This will generate a specific language that can be interpreted by each CAD or CAM application used in the professional workplace.

30 Figure 1b shows the detail of the configuration of the invention. This diagram is comprised of two major entities, the camera (1) and the computer (5), which may be substituted with a specific and dedicated casing (6).

After having chosen a menu on the HIM interface of the computer (48) and started the camera thanks to its own man/machine (HIM) interface (18), the image software (45) of the camera controls the initiation of the reading process of the wide-field (38) and small-field (39) sensors. At the same time, it triggers the LED lighting (15), whether specific or not, depending on the selected menu. This process will also cause the accelerometer (52) to start, which will send its information as a continuous or discontinuous stream to the picture software 1 (45) throughout the process, thus assisting in a correlation of the pictures, and which may at any time substitute one of the sensors, should it fail during the clinical action. The optical system (38) of the large field (20) will allow the image software system to know the field depth and to adjust, if we do not implement liquid lenses, the control (42) itself, adjusting, thanks to a micro-motor (22), the field depth of the optical system (41) of the small field (19) on the oral structures (21). Each of the two images will be captured by the CCD of the large field (38) and of the small field (39). They will be converted into digital data by the A/D converters (43 and/or 44) and/or arrive in analog form on the video control screen (49).

If the hardware supporting the image software 1 (45) uses too large a volume to be located in the camera (1), the second part of this image software (46) will be relocated in a standard (5) or dedicated (6) computer.

The information proceeding from this processing, as described later in this detailed description, will be addressed by all the nowadays known channels (51) capable of performing their processing, whether for diagnosis or for the CAD/CAM. This will be done using a modem (50) that will send its information, in both directions, by wired channels (internet and Ethernet, Wifi or telephone).

For the detail of each part of this invention, we will refer to Figure 2, which shows a dental clinic option in its functional aspect. In order to easily record an intra-oral picture, a 3D reading camera should be little voluminous. Unlike all the known systems, the present configuration enables us to have a very
5 small-size 3D color camera, since its dimensions are between 20 and 25 cm, and has a body that is large enough to ensure a good grip (for example 2 to 4 cm) and a thickness that does not exceed for example 2 cm. It is an extended with an arm of 5 to 6
10 cm, which permits to pass the stage of the lips when recording an impression deep in the mouth. The reading head contains, in a non-hurting ovoid shape, for example 1 to 2 cm thick, aprox. a 2 cm width and a 3 cm length, the complete optical system, the LEDs and the CCD/CMOS sensors.

15 The cross-sectional view in Figure 3 permits us to better detail the components of this camera. In this configuration and this is not restrictive, we have a cross-sectional view showing the head of the camera (7), the arm (8) permitting its insertion into the mouth and the body (9), often outside of the mouth. The head has
20 the cross-section of the optical assembly, here comprised of two optical systems (10) comprising three units (the lenses, eventually the system for adjusting the focal length (22) and the 2 CCD or CMOS sensors) connected to the image connection card (12) via a preferably shielded cable (11), in order to
25 avoid interferences harmful to the quality of the information being transmitted. This card will itself be connected to the computer (5) or to the specific casing (6) through the specific connector (13) depending from the camera (1). This same longitudinal cross-sectional view permits to identify the LEDs
30 placed towards the optical system (14) inside the head protected by the protective glass (17) and/or at the periphery of the optical system, outside the latter (15). A button (18) permits to activate the picture recording, when we do not use the foot pedal. Using a picture-recording system without any offset

allows us to take this 3D image with the button without any risk of blur that could be created by an involuntary movement.

Figure 4 illustrates more accurately the basic principle of the present invention application. We see the schematic representation of the head of the camera (7) and the two different optical systems (10). These systems are comprised, from the bottom to the top, of the focusing and the image-transmission lenses and the CCDs/CMOS. These lenses are shown without focal adjustment system. If we use traditional lenses, it will be necessary to have a focal-length adjusting system (22) permitting to scanning in "z" a field with a 1 to 5 cm field depth.

Advantageously, the lens will be of the liquid type (Varioptic - Fr) or of glass or molded glass/plastic with a pupil on the input face.

The focal length will advantageously be between 0.5 and 5 mm, in order to meet the requirements of large and small field in the limited environment the oral environment represents.

The white and blue LEDs (15) are arranged around the optical system, immediately behind the protective glass (17), whether heating or not. They will preferably be specifically selected based on the desired type of lighting color.

It should be noted that there is no structured light projection, but two areas visualized by the optical system and the CCDs.

Advantageously, the narrow and accurate area (19) is completely included in the less accurate wide area (20) of the teeth measured by optical impression. As we can see, one of the advantages of this method is to include the accurate area in the general area, which largely facilitates the correlation of the two stereoscopic pictures. This also reduces the uncoded areas, since what one camera will not record will be read by the second

one. The mere movement the camera will correct the eventual lack of coding.

Eventually and preferably, the narrow area can also be partially included in the area for purposes of industrial design and size.
5 In this case, the narrow accurate measurement area will overlap the less accurate widest area.

Eventually and advantageously, in order to facilitate the reading of the accurate and narrow area, it is possible to add a displacement motor so that the narrow area quickly scans the
10 entire wide area during the recording of pictures. The displacement motor may use all the techniques of displacement of the lenses.

Eventually and advantageously, this narrow area may be of variable zoom, which allows the operator to vary the desired
15 accuracy in this narrow area between 1 and 20 μm , while benefiting from the large reading field in the wide area.

This stereoscopic camera is comprised of one or several unitary or multiple sensors, two in Figure 4, in a predetermined position, which can be CCDs or CMOS, for example of 2 megapixels
20 at 2.2 μm , (25 to 500 images / second) defining, by their renewal, the reading speed, thus the speed of recording of successive impressions permitting a static or dynamic reading, as we know for a photo camera or a video-camera. We can thus have a dynamic view by moving over the area of analysis, unlike
25 with the profilometric phase systems that require a minimum of four pictures for extracting the relief, the system used in the present invention only requires a single frame or a double frame at two levels of accuracy, avoiding any movement in the measurement, or the integration of the information on the sensor
30 is immediate and simultaneous.

It is also comprised of an optical assembly having one focal length or at least two different focal lengths, which can

ranging from a numerical aperture (NA) of 0.001 to 0.1, and permits to transmit to the sensor(s) of the camera, without distortion, the data visualized on the two or several operatory fields. For example, for the intra-oral pictures, in the example shown in Figure 4, these fields can be described as follows:

- a. one of the fields covers a large surface, but with a lower resolution, for example and this is not restrictive, of 20 μm (NA: 0.0125, i.e. a focal equivalent of F/8) over a field of 30x20 mm.
- b. the other field is smaller, but more accurate, for example and this is not restrictive, with a resolution of 10 μm (NA: 0.025, i.e. a focal equivalent of F/4) over a field of 15 x 10 mm. The field depth is small, a series of picture recordings with a variable depth is foreseen.
- c. The small field is fully included in the large field, at all levels, whether centered or not, in order to detect the data for the generation of the three dimensions of the object (x, y & z) and to facilitate the real-time correlation between the accurate views and the general larger-field views.
- d. The objective can be comprised of several glass or molded glass/plastic elements, the adjustment being performed by a micro-motor.

Eventually and advantageously, this adjustment the field depth on the teeth will be carried out using a liquid lens, in order to ensure a perfect adaptation based on the proximity of the intra-oral surfaces and to avoid the use of a micro-motor.

Eventually and advantageously, it can also be comprised of a lens, for example a thermoplastic lens referred to as "free-form" comprised of a flat top surrounded by n asymmetric facets

ensuring, in one picture recording, the visualization of the oral environment according to n different viewing angles. The faceted portion is oriented towards the sensor and the flat side towards the oral environment. The sensor will receive n slightly different images with views from a different angle depending on the angle of cut of the facet with respect to the flat surface. Thus, in one single recording of pictures is possible the capturing and digitizing of n instantaneously correlated stereoscopic views of different surfaces, avoiding the addition of a second sensor and a second optical system.

Eventually and advantageously, if we have a single sensor, no longer the predetermined position of the sensor all the views, as we have seen previously, but the sequences of successive captures will define. The displacement movements correlated with a sequence of automatic picture recordings will define the different planes of picture recording. For example, the first image will be recorded at time T0, then a slight shift, which will lead to a change in angle of viewing, will be followed by a new recording at time T0 + 1 second (for example) and so on.

Eventually and advantageously, an accelerometer, a gyro or a 3D magnetometer (52) will be installed near the CCD/CMOS sensor, in order to assist with the correlations and to compensate for an eventual failure of one of the sensors. According to the present invention, in order to avoid any interruption in the clinical action or to replace one of the fields (large or small as the case may be), it will be for example a 3D accelerometer with a frequency of acquisition higher than or equal to 50Hz, an interval of +/- 10g and an accuracy lower than or equal to 3 mg.

Eventually and advantageously, the general information on the field depth will be indicated by one of the sensors, for example the wide-field sensor, so that the focal length of the other, small-field sensor is prepositioned in an area close to the reality analyzed by the first, for example-wide field sensor.

Figure 5 shows the volume measured in the mouth of a patient. The small volume, in which the dentist can move his camera, considerably limits the possibilities of having both a wide field and a high accuracy. With the new concept introduced here, and sticking to the laws of optical physics, it is possible to measure a volume of 20 x 30 mm and a field depth of 2 mm with an accuracy of 20 μm at the level of the wide field. The narrow field limits the volume to 10 x 15 x 0.5 mm for an accuracy of 10 μm . This is given only by way of an example and can vary significantly depending on the qualities of the optical systems being used. These values are consistent with the requirements of an optical impression in the mouth for making good prostheses and good diagnoses.

The field depth is insufficient, but it is laid on by the proximity of the teeth with respect to the optical system laid on by the space between the upper teeth and the lower teeth. In order to solve the problem of field depth, a series of picture recordings is provided for in Figure 6, by varying between 10 and 20 times in the accurate area and between 5 and 10 times in the wider area. This ensures accuracies within 10 μm (small and accurate narrow field) and within 20 μm (less accurate wide field) with a field depth between 10 and 30 mm, which is sufficient in dentistry.

Eventually and advantageously, these movements in field depth in the narrow field and in the wide field can be synchronized or not depending on the needs of the recording of optical impression. As we will see in the software processing, this adjustment can be limited, since the CCD/CMOS can recognize whether the collection of information is unclear or not. This provides an information on the position of the teeth with respect to the optical system and enables an automatic-adjustment of the field depth. This also provides the advantage of limiting the scanning in depth and of limiting the successive picture recordings.

In Figure 7 we have the representation of the area scanned by the wide field (23) and by the succession of pictures of the accurate and narrow field (24). As we can see in the example given, ten pictures are sufficient to cover an entire field with an accuracy of 10 μ m.

In fact, the dentist will position its accurate view on the central area requiring oral maximum accuracy. This area can be the finishing line of a preparation, but also, as we can see in Figure 7, the grooves and the cusps of the teeth. As will be presented later in the description of the "software", in particular in Figure 13 (stacked surfaces strategy), a judicious use of this high-precision area largely contributes to a high-fidelity reconstruction. The area common to both cameras is used for reconstruction and largely benefits of the level of details provided by the accurate field. On the other hand, by moving the head randomly, and thanks to the high frequency of acquisition of images, the user has a great chance to cover the whole area to be reconstructed by the part common to both cameras. Finally, should an area exhibit insufficient accuracy, visual feedback will be provided to the user, who can then focus the accurate field on this area, in order to achieve sufficient accuracy.

As can be seen in Figures 8a, 8b and 8c, a 3D stereoscopic view is possible when it is possible to correlate homologous dots found in each of the pictures recorded together or with a slight time shift. Figure 8a shows the automatic determination of the homologous dots in two occlusal and lingual pictures of the same teeth on a dental plaster (Figure 8a - 26). This automatic determination is possible with the software, which is an integral part of our invention.

The lines that we can see unit identical and homologous dots identified in each of the two pictures. The same representation can be made on an intra-oral view (Figure 8b - 27) thanks to the software system.

Eventually and advantageously, the "software" permits this automatic identification of the area of focus in the area of field depth, while noting that everything happens for areas outside the field as if they had been subjected to a low-pass filter with respect to areas inside the field; therefore, the local power spectrum has a softer slope. The power spectrum is thus calculated in "patches" p of the image (typically a 20×20 pixel square area), the decreasing slope α_p of which is approximated according to a decreasing exponential model. Then, the ratio $(\alpha_p - \alpha_0) / \alpha_0$ is calculated, where α_0 is the decreasing slope for the entire image. Is this ratio below a certain threshold adapted to the image, then the patch is considered outside the area of focus.

The result is a representation of a scatter diagram arranged in space (Figure 8c - 28), a part of which is very accurate (less than $10 \mu\text{m}$).

Eventually and advantageously, this representation as a scatter diagram is also performed thanks to the 3D reconstruction techniques described in Figure x.

Eventually and advantageously, this representation can also be made by a dense, polygonalisée and textured representation close to the actual visual representation, at the Bezier surface, by Radial Basis Functions, by NURBs, or by wavelets.

In this case, the software will proceed as described in Figure x, in order to perform this modeling. Schematically, the sparse scatter diagram generated by the 3D reconstruction (Figure x) is interpolated using the technique described in figure y. This technique has the advantage of densifying the scatter diagram and of modeling it by means of soft Radial Basis Functions type curves. (Without loss of generality, the modeling can be performed for example, and this is not restrictive, by Bezier curves, by Radial Basis Functions, by NURBs, or by wavelets.) Once the surface model is applied, polygonalization occurs by

means of a conventional technique (for example, and this is not restrictive, Bloomenthal technique, ball pivoting, Poisson reconstruction), then a texture as described in Figure 2 is calculated and applied.

5 The advantage of these modeling methods in real time or almost in real time is that they permit, starting from a stereoscopic view, an immediate 3D representation on the practitioner's display screen. He can vary the orientation and zoom digitally on all or part of the impression, in order to verify and/or
10 validate his work for the following part of his clinical operations.

Fig. 9 shows the LEDs providing sufficient light for a good stereoscopic recording. In order to achieve an accurate and complete measurement, it is necessary to have a good lighting of
15 the scene. The question is not at all to project structured light, but only to light the scene in a relatively dark mouth.

Eventually and advantageously, the lighting will be LED lighting for powers that can vary between 10,000 and 500,000 lux of white light and between 5,000 and 300,000 lux of blue light.

20 That is why a few LEDs are sufficient. In Figure 9a are shown two white LEDs (29) among the eight that are necessary to achieve 200,000 lux of white light and 1 blue LED (30) among the 4 blue LEDs that are necessary to achieve the 100,000 lux of blue light.

25 Eventually and advantageously, other LEDs will be added which have an unstructured light, but with the exact characteristics in terms of purity (consistent or not), of type (color) and intensity (power). In Figure 9a is shown, for example, and this is not restrictive, a green LED (31) permitting to develop some
30 functions of assistance to the diagnosis on a 3D image, transferred onto our 3D surfaces.

This is the more interesting as since we are not using structured light, it is always possible to perform real-time color analyses in the mouth of the patients, both at the level of the mucosa and at the level of the mineral structures of the tooth or the prosthetic reconstruction materials.

Eventually and advantageously, the light will be chosen so that it can highlight mineral or organic carious fractures or damage in the crystal of the tooth. This is particularly interesting because the display will not occur on 2D images, as presently known, but on structures shown in 3D highlighting the areas to be analyzed, diagnosed or treated. This also allows the practitioner to follow up the quality of his work and to be sure, on 3D images, he has properly treated the highlighted disease.

Eventually and advantageously, this permits to highlight fractures in the restorative materials (as for example a slit in the zirconia ceramics) and to assess whether a new intervention on the reconstitution is necessary.

Eventually and advantageously, in addition to diffuse LED light, in order to assist the practitioner in knowing where the high-precision reading is located (narrow field in the wide field), the projection of a target (Figure 9b - 32a) surrounding this specific area is eventually foreseen.

Eventually and advantageously, other LEDs will be added, which have a non-structured light, but with the specific characteristics in terms of purity (consistent or not), type (color) and intensity (power). In Figure 9a is shown, for example and non-restrictively, a green LED (31) permitting to develop some functions of assisting to the diagnosis on a 3D image, transferred onto our 3D surfaces.

Eventually and advantageously, the projection of a frame surrounding the wide field (32b) is provided for, which avoids

the practitioner from following his scanning on the screen during the recording of an impression in the mouth.

Using these blue and/or white LEDs has the advantage of permitting an easier search for homologous points and to
5 determine a higher number of them on a tooth that has a crystalline and slightly penetrating structure. Eventually and advantageously, though the penetration of a diffuse LED light is not comparable to that of structured light projected on a
10 surface of the tooth, the blue light will be used to make them look more chalky, avoiding the use of a covering layer referred to as coating.

Eventually and advantageously, the lighting system with LEDs of various wavelengths or colors, the mix of which will be chosen, for example, so as to create fluorescence or phosphorescence
15 effects in the crystals of the tooth or in some parts or pathologies of the gum. This will further promote the display of the surface of the mineralized tissues in the blue or the UV, since a fluorescent tooth tissue has a particularly "mat" aspect, which avoids the surface or paint deposition referred to
20 as coating.

This same application finally allows us to penetrate into finer gum areas, such as they exist in the dental sulcus. This permits the operator to have a view on the emergence of the tooth through the gum. Likewise, the choice of a judiciously selected
25 complementary color, for example, among the red, permits to reduce the harmful effects of blood and saliva and facilitates the recording of an optical impression.

Advantageously, these LEDs will have a variable power and color, in order to light, at low power, the measured surface or, at
30 high power, to cross some small thicknesses of the epithelial tissue.

Through the mounting as provided for in this method, as Figures 10a, 10b and 10c show, a reading in white light is provided for, in order to have the exact color of the mouth environment (33) and eventually the addition of a picture recording in
5 complementary light, for example and non-restrictively in blue light (34) or an association of the complementary light and the white light (complementary blue at 35).

Eventually and advantageously, one or more of the color components added to the white light will be subtracted, in order
10 to arrange and represent on the screen and in real time the real color of the measured oral environment.

Eventually and advantageously, this choice of the LED color can be predetermined or automatic. If the scatter diagram is insufficient during a reading in white light, the system
15 automatically (or manually) activates the complementary LEDs, for example the blue LEDs, and the system records again the same picture. The addition of the blue and white pictures multiplies the chances of increasing the information on the surfaces and the search for homologous dots.

Eventually and advantageously, these LEDs can also have a predetermined wavelength permitting to highlight the natural anatomic elements (bottoms of furrows or color areas differentiating tumors, gums or tooth shades) or markings made before the recording of impressions and made by means of
20 specific and predefined colored markers.

These markings can advantageously be objects of different shapes placed in the measured area, glued or accommodated for example on the teeth, in the spaces between the teeth or on the implant heads, in order to facilitate the correlation of the pictures,
30 but also in order to know the exact spatial position of these predefined marks.

In the case of implants or dental canals, this will permit to know some inaccessible areas during the optical reading. The identification of the mark and a priori knowledge of the carrying shape will permit to derive the shape and the spatial position of the hidden part.

The light combinations permit to highlight details on the areas with a weak texture, which do not appear under "natural" light. An optimal combination will be provided to the user by default: however, several pre-established combinations (which can highlight the markings, for example) will be provided.

The light combination permits, on the other hand, to have additional information for each spectral band. Thus, when we will present the algorithm for searching optical traces in figure x, the processing is not performed on the global image, but in parallel on the three spectral bands. The optical traces used for the 3D reconstruction result from the combination of the traces obtained for the three spectral bands.

In Figure 11, two additional functions required in the mouth are shown. Very often, during a recording of an optical impression, three optical elements that can degrade the information are avoided. They are blood, due to the preparation of the tooth, saliva that naturally flows in an open mouth, and mist that appears on a surface colder than the mouth.

For this reason and for reasons of comfort and accuracy, it is foreseen to associate with the camera, in the reading head, a spray of air or liquid, of which can be seen the aperture (37), which is directed towards the reading area. This permits to evacuate saliva or blood during the reading.

Likewise, the glass protecting the optical system and the LEDs in the head of the camera, is designed as a heating glass, for example between 20 and 35°, depending on the seasons, so as to limit the deposition of mist on the protective glass.

Figure 12 shows the general diagram of the software portion. This diagram permits both to provide a real-time 3D reconstruction during the acquisition and to ensure spatial high-fidelity of the final model.

5 A first reconstruction is performed in real time and sequentially: when images are acquired (53), a regional 3D reconstruction (54) is calculated (from this only pair - if two cameras - or with a few preceding pairs - if a single camera) then added to the global reconstruction as it was before the
10 acquisition of this pair. The reconstruction is instantly displayed on the screen (55), eventually with annotations on its local quality, enabling the user to visually identify the areas in which a second pass would eventually be necessary. The sequential reconstruction is continued until the user completes
15 the acquisition of images.

Once the acquisition is complete, we proceed to the final adjustments of the reconstructed 3D model: enhancement of the accuracy of the model and estimation of the scale factor. The total duration of the final adjustment does not exceed 5
20 minutes.

First of all, the 3D reconstruction may require a scaling (56) when the images were acquired from a single camera. The estimation of the scale factor to be applied to the reconstructed 3D model is performed by means of a filter, for
25 example, and this is not restrictive, a Kalman filter, and uses both the measurements for example, and this is not restrictive, from the accelerometer and those from the images (relative positions of the cameras with respect to each other).

Furthermore, the real-time 3D reconstruction is refined in order
30 to increase accuracy (57). The precision-gain technique is detailed in Figure 17.

Figures 13a, 13b and 13c schematically show how the pictures acquired from the two cameras can be used. To this end, three ways of operating, and this is not restrictive:

5 * Figure 13: When a pair of images is newly acquired by the two cameras, we look for the optical traces (dots of interest and correspondences) among the two images (algorithm shown in Figure 15). The corresponding dots then permit, by triangulation, to calculate the corresponding 3D dots. Triangulation is extremely simple
10 in the case of two cameras, since we are in a calibrated configuration, in which we know the intrinsic (focal length and distortion) and extrinsic (relative positions of the cameras with rest to each other, by construction of the camera) parameters.

15 The 3D scatter diagram generated is then interpolated, polygonalized and textured (algorithm shown in Figure 16). A validity index q (57) is then calculated for each element (for example, and this is not restrictive, triangle or tetrahedron) of the polygonalized 3D

20 reconstruction. We will chose $q = \frac{216 * \sqrt{3} * V^2}{(a+b+c+d)^2}$ ($V =$
volume, $a, b, c, d =$ length of the sides of the tetrahedron, for example, and this is not restrictive).
25 If, at a point, this index is lower than a certain threshold, the reconstruction element is labeled as
invalid, which will permit a real time visual feedback to the user during the phase of display, so that the user
can acquire new pictures in this area and thus obtain a sufficient quality. A global index of validity of the
30 reconstruction generated by the pair of images is also derived, by calculating the percentage of invalid
elements compared to the total number of reconstruction elements. If this percentage is lower than a certain

threshold, the generated surface will not be integrated into the reconstruction.

5 The generated surface, if valid, is integrated into the partial reconstruction for example by resetting, and this is not restrictive, of the non-linear Iterative Closest Point type followed by a simplification (removal of
10 redundant 3D dots or outliers). Eventually and advantageously, the integration into the partial reconstruction can be done by performing a tracking of the relative positions of the cameras by an algorithm similar to that shown in the following figure.

Finally, the reconstruction phase is followed by a phase of display.

- 15 * Figure 13b: Alternatively, the images from the two cameras can be used independently. Two regional 3D reconstructions can be calculated independently for the wide-field camera and the small-field camera, thanks to the algorithms shown in Figure 14. Since the small-field reconstruction is calculated based on images that
20 integrate into a fixed position in the large-field images, it can be directly integrated into the large-field reconstruction. The end of the algorithm is then similar to the case shown in Figure 13a.
- 25 * Figure 13c: Alternatively, the images of the small-field camera can be used only sporadically. During the acquisition, then they are stored, but not automatically processed. The reconstruction is carried out only from the wide-field camera, thanks to one of the algorithms of Figure 14, then the local quality indices are calculated.
30 For the invalid elements, one looks through reverse projection to which portion of the large-field 2D image they belong, then one looks in the small-field image database whether some images (typically some ten images)

cover this area. A local reconstruction is then calculated based on these small-field images, then the validity indices are re-calculated. If the latter are above the threshold, then the small-field reconstruction is integrated into the large-field one in a way similar to Figure 13b.

Figure 14 details the two strategies usable for reconstructing the 3D model from a single camera. The complexity of the algorithms used in this case results directly from the freedom given to the user to use the system without any constraint. Thus, the movements of the system cannot be predicted; in other words, when the picture recordings are acquired, we cannot know a priori from where these pictures have been recorded. It is then up to the algorithms to find the specific spatial organization of the pictures, in order to ensure a faithful reconstruction of the object.

- Sequential Case: We work in a projective geometry, which requires from the start of the acquisition to choose a pair of images serving as a geometrical reference. The choice of these first two pictures is essential to avoid falling thereafter into a problem of local minima. Among the first images of the acquisition, the initializing pair is selected such that:

- o The number of matches between the first two pictures is at least 400.

- o The distance between these two pictures is large enough: arbitrarily, we will wait for the data from the accelerometer that at least 5mm have been covered; otherwise (if the operator remains immobile), we will wait until at most 40 images have been acquired.

From these first two pictures, a first estimate of the geometry is performed:

- o The optical trace is calculated between these 2 images (algorithm of Figure 15)
- 5 o The projection matrices P_1 and P_2 (representative of the spatial position of the cameras) are calculated from the matches by a conventional 5-point algorithm.
- o The corresponding dots are triangulated, in order to obtain an initial estimation of the 3D dots.
- 10 o The geometry is updated by self-calibration, in order to pass from a projective geometry to a nearly-metric geometry (within one scale factor).
- o The generated 3D scatter diagram is then interpolated, polygonalized and textured (algorithm in Figure 16). The generated surface is the first
15 estimate of the partial 3D reconstruction.

Then, the reconstruction is enriched thanks to any newly acquired picture i :

- 20 o the optical trace is complemented by calculating the dots of interest in this picture and by matching it with the previous picture (58).
- o Knowing the correspondence with certain dots of interest in image $i-1$, and knowing the coordinates of 3D points that are projected onto these dots of
25 interest, it is possible to estimate the projection matrix P_i , for example and this is not restrictive, by re-sectioning (59).
- o Since all the projection matrices are now known until image i , we re-estimate the 3D dots linearly based on

5 these matrices and the optical traces. In practice, in order to maintain the real-time constraint, we only work on the current picture and the n previous pictures (typically, n=3 or 4). The total geometry on these n pictures (projection matrices and 3D dots) is then refined by a non-linear algorithm for example, and this is not restrictive, of the Sparse Bundle Adjustment type.

- 10 • The total 3D scatter diagram is again interpolated by multiscale RBF, then polygonalized and texturized.
- The local indices of validity are calculated, and then follows the visualization phase.

15 • Case by sub-sequences: The sub-sequence strategy calculates partial reconstructions for sub-sequences of images, formed by isolating spatially coherent groups of images and having a large number of corresponding dots. One proceeds as follows:

20 ○ Sequencing algorithm: The video stream is divided into sub-sequences, referred to as regions, as the acquisition progresses, after calculating the optical traces. If the optical search occurs by tracking, a region ends (60) when the percentage of dots still in tracking phase drops below 70%; for the other optical search techniques, the region ends when the number of

25 matches with the first image of the region is lower than 70% of the dots of interest of the current image. When the current region is closed, a new region is created and initialized with the new image being acquired.

30 ○ As soon as an area is closed (61), the relative positions of the cameras and the 3D dots corresponding to the optical traces found in this region by an

factorization, for example and this is not restrictive, of the Tomasi Kanade type are calculated in parallel. The generated 3D scatter diagram is interpolated, then polygonalized and textured (algorithm of Figure 16).

- 5 o The geometries differ by region when this algorithm is used as is; the generated surfaces are thus not coherent in space. In order to bring all the regions in the same geometry (62), one should be careful to put some images (typically 3) artificially in common
- 10 between 2 adjacent regions, which will permit to derive a transformation homography between pairs of adjacent regions. The homography is applied to each end of the generated surface, in order to integrate it into the global model.
- 15 • The local indices of validity are calculated, then follows the visualization phase.

Figure 15 shows an example of calculation of an optical trace by tracking dots of interest. The dots of interest of the current image are represented in it by squares (63), while the lines

20 represent the positions of these dots of interest in the previous images.

The search for noticeable optical traces of 3D dots occurs by searching dots of interest in all the acquired 2D images, then by searching matches between the dots of interest of different

25 images. Several schemes are possible:

- Optical Tracking of Angles: The general idea is to calculate noticeable dots (angles) in an image, then to track these dots in the following images without having to re-detect them. The tracking phase continues as long as a
- 30 certain percentage of noticeable dots of the first image is still detectable (typically 70%) ; below this threshold, a

new detection phase of noticeable dots is conducted on the following image.

The detection of angles occurs by calculating for any pixel

$$(x, y) \text{ the } 2 \times 2 \text{ matrix } C = \begin{bmatrix} \sum_w \left(\frac{\partial I}{\partial x} \right)^2 & \sum_w \left(\frac{\partial I}{\partial x} \right) * \left(\frac{\partial I}{\partial y} \right) \\ \sum_w \left(\frac{\partial I}{\partial x} \right) * \left(\frac{\partial I}{\partial y} \right) & \sum_w \left(\frac{\partial I}{\partial y} \right)^2 \end{bmatrix}, \text{ where}$$

5 I denotes the intensity in (x, y) of the image and W a surrounding of (x, y). Let's assume that λ_1 and λ_2 are the 2 eigenvalues of this matrix; if these 2 values are above a certain threshold (typically 0.15), the dot is considered as a noticeable dot.

10 For the tracking, we look, among 2 images i and i +1 and for each noticeable dot, the displacement $d=(d_x, d_y)$ that

$$\text{minimizes } \sum_w \left(I_i(x, y) - I_{i+1}(x + d_x, y + d_y) \right)^2. \quad \text{This}$$

displacement is calculated by $d=C^{-1}.b$, C being the 2*2

$$\text{matrix evoked above, and } b = \sum_w \begin{bmatrix} (I_i(x, y) - I_{i+1}(x, y)) * I_i(x, y) \\ (I_i(x, y) - I_{i+1}(x, y)) * I_{i+1}(x, y) \end{bmatrix}.$$

15 Since this optical tracking technique is reliable for small displacements, the contingencies of large displacements are coped with by sequentially calculating the displacement d on a pyramid of images (from a largely subsampled version of the images to the original resolution).

20 The above-mentioned techniques are based on the implicit assumption that the stream of images is consistent, i.e. the displacement between 2 successive images is small, and 2 successive images are of sufficient quality to find a satisfactory amount of matching dots (at least 30).

25 As regards the displacement between 2 images, the acquisition of the images occurs at a conventional video-

stream frequency. We can therefore expect a very small displacement between 2 images. For a larger displacement that would result into an impossibility of finding dots corresponding with the previous images, a new region can be generated.

As regards the insufficient quality of an image (in the eventual case of a blurred image, for example), the matching phase acts as a filter, since it is clear that very few matching dots will be found. The image will then be stored without being processed, and one will wait for the next image that will have a sufficient number of matching dots.

• Unchanged dots + matching at least squares: The dots of interest are sought in the 2D images by well-known techniques, which look for dots that remain unchanged under change of scale and illumination. These techniques have the advantage of being capable of calculating morphological descriptors for each dot of interest.

The matching between dots of interest for a given pair of images is performed by searching for any dot of interest x_{11} in image 1, the dot of interest x_{12} in image 2 minimizing the distance at x_{11} at the least squares in terms of descriptors. In order to avoid false matches or outliers, the fundamental matrix F will first be calculated between images 1 and 2 (which binds the pairs of dots of interest by the ratio $x_{11}.F.x_{12}^t = 0$).

If, for a pair of potentially matching dots of interest x_{11} and x_{12} at the least squares, the product $x_{11}.F.x_{12}^t$ is larger than 10^{-5} , the pair is rejected.

The search for an optical trace then occurs by transition during the acquisition of a new image. When acquiring image I_j , it is assumed that the calculation of the optical trace

was performed for all previous images $I_1 \dots I_{j-1}$. The dots of interest I_j are then calculated, which are brought into correspondence with image I_{j-1} . The optical traces are then complemented by transition, whereby it should be noted that if x_{ij} is in correspondence with $x_{i,j-1}$ and $x_{i,j-1}$ is in correspondence with $x_{i,j-2}$, then $x_{i,j-1}$ is in correspondence with $x_{i,j-2}$.

• Strong gradients + matching by correlation: As dots of interest of an image are considered all the dots where the variations in intensity are important. In practice, for each dot of the image considered is calculated the standard deviation of the intensities in a 20×20 pixel surrounding around this dot. If the deviation is above a certain threshold (typically in the range of 10, for intensities coded on 8 bits), then the dot is considered as a dot of interest.

The search for matches between 2 images at the level of their dots of interest occurs by a correlation technique, for example and this is not restrictive, of the Medici type (French Patents filed on 29.03.2005 EP1756771 (B0453) and EP0600128 (B0471)).

Figure 16 shows three simplified steps of the real-time 3D reconstruction algorithm. The reproduction (65) is one of the 2D images of the acquisition to be reconstructed. The reproduction (66) represents the scatter diagram generated by one of the algorithms for calculating the 3D scatter diagram. The reproduction (67) shows the partial 3D reconstruction calculated based on the reproduction (66) thanks to the algorithm for interpolating the scatter diagram, polygonization and texturing detailed below.

The 3D modeling follows three steps. In the first step, the 3D scatter diagram obtained by processing the optical lines is densified by calculating an implicit interpolation function f .

Thanks to this implicit function, the 3D surface interpolating the points is polygonalized for example by means of the method, and this is not restrictive, such as Bloomenthal. Finally, each polygon is textured in a very simple way: by projecting the 3D points delimiting the polygon onto the images that generated these points, a polygonal area is delimited on these images. We then determine the average value of the texture of these polygonal areas, and it is assigned to the polygon.

The main difficulty resides in the algorithm used for interpolating and calculating the implicit function. This algorithm is optimally adapted to our use, because it permits a real-time interpolation and, unlike other interpolation techniques, it permits a dense interpolation from a very scattered initial diagram, which is very often the case when working with objects with little texture like the teeth. Below we explain the generic interpolation underlying this algorithm, then its use in practice in a multi-scale scheme:

- Generic Interpolation: Assuming that P_i represents the dots of the 3D diagram (after estimation of the normal \vec{n} at these points), we will search for the implicit function $f: R^3 \rightarrow R$, based on RadialBasis Functions (RBF) such that the points X belonging to the surface are those for which $f(X)=0$. We choose f such that:

$$f(x) = \sum_{p_i \in P} [g_i(x) + \lambda_i] \cdot \phi_\sigma(\|x - p_i\|), \text{ with}$$

$$\phi_\sigma(x) = \phi\left(\frac{x}{\sigma}\right), \phi(x) = (1-r)^4 + (4r+1)$$

The unknowns to be determined to explain f are thus the g_i and the λ_i .

Estimation of the g_i : Let's consider the point P_i and its normal \vec{n}_i , let's choose a system (u, v, w) such that u and v are perpendicular to the normal and w points in the direction of the normal. Assuming that h is a function of the form $h(u, v) = Au^2 + Buv + Cv^2$, we look in P_i for the coefficients A , B and C so as to minimize the following quantity $\sum_{p_j \in P} \phi_{\sigma}(\|p_i - p_j\|) * (w_j - h(u_j, v_j))^2$. We then calculate $g_i(x)$ by $g_i(x) = w - h(u, v)$.

Estimation of the λ_i : Knowing that $f(P_i) = OVP_i$, we can estimate the λ_i by simply solving the linear system.

• Multiscale Interpolation: The generic interpolation is actually conducted on subsets of points, in order to largely improve the accuracy of the interpolation. We first of all construct a set $\{P_0, \dots, P_k\}$ as follows: the set P_0 is a parallelepiped including the set of points P_i . Between 2 successive levels $k-1$ and k , a subdivision of parallelepipeds into 8 small parallelepipeds made.

The function f is calculated by an iterative procedure. We start with $f^0 = -1$, then we iterate on the sets P_k by updating f :

$$f^k(x) = f^{k-1}(x) + o^k(x), o^k(x) = \sum_{p_i^k \in P_k} (g_i^k(x) + \lambda_{ki}) * \phi_{\sigma^k}(\|x - p_i^k\|)$$

The g_i^k are determined as described above on the set P_k , and the λ_i are calculated by solving the system $f^{k-1}(p_i^k) + o^k(p_i^k) = 0$.

The σ^k are updated such that $\sigma^{k+1} = \frac{\sigma^k}{2}$, and the number of levels to be constructed is defined by $M = -\log_2\left(\frac{\sigma^0}{2\sigma^1}\right)$.

Figure 17 shows the 2 steps of enhancement of the accuracy:

- 5 • Global calculation of the geometry (68): In contrast to all the real-time 3D reconstruction techniques presented above, we use, at the end of the acquisition, a re-assessment of the spatial positions of the cameras and the 3D points based no longer on some images (fixed number of images if sequential strategy, region if sub-sequential strategy),
10 but on all the images of the acquisition.

We therefore use an algorithm of the type Sparse Bundle Adjustment, with as the initial estimate the positions of the 3D points and the projection matrices of the cameras as they were at the end of the acquisition. The scatter
15 diagram is finally densified by the interpolation algorithm evoked above.

- 20 • Space carving (69): Once the global 3D scatter diagram has been re-calculated, the global 3D reconstruction consists of a Delaunay triangulation of the diagram. This triangulation provides a much too dense set of polygons, not taking into consideration the visibility of the points. In order to segment this model and to extract only the visible information, we perform a graph-cut type segmentation aiming at minimizing the energy $E = \text{visibility} + \text{photo-consistency} + \text{surface}$, with:
25

- o Visibility: for each tetrahedron of the model is known from which cameras it was reconstructed. It is thus visible from this camera and no other tetrahedron should be located between it and the

camera. Thus, for each tetrahedron, the term visibility counts the number of tetrahedra between it and the camera.

5 o Photo-consistency: Let's assume that $p(T)$ is a photo-consistency measure for a triangle T of the reconstruction. (Traditionally, we can take the average value of the differences between the texture of this triangle and the textures of the 2D points, which its vertices are derived from). The term
10 photo-consistency energy to be minimized is equal to $E_{photo} = \sum_T p(T) \cdot \text{aire}(T)$. In the case of the minimization per graph cut, we will minimize by adding to the graph, for each pair of tetrahedra sharing a triangle T , two nodes p and q with a weight edge
15 $W_{pq} = p(T)$.

 o Surface area: we try to have a surface with an as small as possible surface area. We will minimize by adding to the graph, for any pair of tetrahedra sharing a triangle T , two nodes p and q with a
20 weight edge $W_{pq} = \text{aire}(T)$.

The handling of such a system is extremely simple because its characteristics are deemed fixed and unchangeable by the operator, except the type of selected lighting, although this
25 function can be controlled by a sequence of automatic actions leading to the desired diagnosis. To this end, the operator (dentist, dental technician or physician) has a computer showing him the operations the camera can carry out and permitting him to choose between one function and another one.

30 All or part of the treatment can occur at the level of the cards included in the camera, whereby the rest of the treatment can eventually be performed by a generic system (laptop or standard

desktop computer) or a specific system including cards specifically dedicated to the application of processing, transmission and data display.

Thus, in "measuring" function, after having selected this mode
5 of action, the operator starts the measurement, using a button located on the camera, or a pedal in communication with the computer, the camera or on the intermediate casing, after having positioned the camera over the area to be measured and stops it when the feels he has enough information. To this end, he stops
10 the pressure, or presses a second time.

The camera is, in this case of picture recording in the mouth or on a plaster model, moved over the arch, in order to collect the color 2D information, x and y, on each of the sensor(s), which can be CCDs/CMOSSs with or without accelerometers.

15 The software processing permits to calculate practically in real time the 3D coordinates (x, y and z) and the color of each of the points measured on x and y. We obtain a 3D file of a partial or complete arch in color.

20 The successive recordings of images, a real film of the area to be measured, permit a complete record of the information necessary for the digital processing of all or part of the object measured in the vestibular, lingual and proximal area. A slight light pattern permits to indicate the successive picture recordings to the operator.

25 The knowledge of all the points of all the surfaces of the two measured arches also allows the operator to re-record certain insufficiently accurate areas. These areas are identified automatically by the software by means of different real-time systems such as the existence of a lack of information on the
30 scatter diagrams (wide detection) or the existence of aberrant dots with respect to their immediate vicinity (local detection).

This same detection can occur at the level of the modeling curves (Nurbs, radial basis functions, wavelets).

5 These areas will be marked with a color or by another method capable of drawing the clinician's attention. The latter will take again the camera and the identification of the new points with respect to the known points will permit to fill in the inaccurate spaces or areas. This operation can be facilitated by numbering the areas to be read again, a reading order to be followed, and/or the presence of a 3D accelerometer.

10 These data undergo, on the one hand, an analog-to-digital conversion and, on the other hand, are eventually processed in the form of a video signal directly usable in real time by the conventional display screens.

15 Having a colored image also allows the operator to have an automatic analysis of the dental (usually white) and gingival (usually red) areas, which is impossible with the current methods using the projections of structured light. Likewise, through positioning an index of known color he has the possibility of carrying out a discriminative analysis in order
20 to identify objects in the image, but also their position (implant or screw heads, orthodontic brackets ...) or also to facilitate the correlation of the pictures (colored marks, lines on the object or selective colors such as the bottoms of furrows...)

25 This discrimination has another advantage at the level of the software. Since the current methods often do not have the color analysis, because of the projection of structured light, they have so-called "unrelated" surfaces, which disturb, even impede the automatic correlation of the pictures. They require a manual
30 cleaning of the pictures, which operation is time-consuming and expensive. Being able to distinguish between the gum (red) and the teeth (white) will permit to remove the unrelated areas based on the color information. Thus, in an analysis surface of

the preparations of the teeth, all red unrelated areas will automatically be deleted.

5 Finally, in the measuring function of our invention, the high accuracy of 10 μm is not always necessary and that of the wide field is sometimes enough (20 μm). In dentistry, the practitioner, who wants to carry out a diagnosis or an impression, in order to make a prosthesis or an implant, needs two types of approaches, a fast one, which provides him only with the necessary information (in terms of measured surface and provided accuracy), and the other one, a complete and accurate 10 one. For example, making a crown on a mandibular molar tooth can be done by dental CFAO when the optical impression of the preparation area is accurate, complete and neat, when the optical impression of the opposing teeth provides at least the 15 measures of the points of contact (cusps, furrows) and the arch forms, which does not require the same attention. Likewise, an impression for a device for straightening the teeth (orthodontics) will not require as much accuracy as the one for making a ceramic bridge on implant heads.

20 Eventually and advantageously, the present invention permits to select independently from each other wide-field or narrow field accuracies, thanks to the software implemented in image processing (Figure 1b). It is possible to quickly construct large-area color surfaces or, on the contrary, to construct 25 narrow areas with high accuracy, by putting into operation only either one of the sensors, preferably associated with the accelerometer the function of which will be to replace the inactivated sensor. This substitution is not necessary, but is a supplement that guarantees the accuracy of the correlation of 30 the pictures.

In the function referred to as "diagnosis", he selects on the computer the desired type of diagnosis, e.g. melanoma, and the camera will start a scanning with a wavelength corresponding to

highlighting the areas of interest for the pre-selected wavelengths present on a 3D image. In addition, and through the 3D analysis of the object, the recovering of the measures over time will permit to better follow the evolution of said pathology. It is indeed recognized by the professionals that the study of a suspicious image can be made in 2D, but especially the evolution of its volume and its color serves as a reference for monitoring its dangerous character over time. Having a volume referred to a mathematical center (e.g. the microbar center) permits to superpose images on a center depending on the object, and not on the observer, in order to objectively assess the evolution of its volume, the color analysis being transferred onto a 3D form, which is not the case today with the methods performed on 2D surfaces or those using structured light or waves (OCT, scanner or MRI).

Likewise, thanks to the 3D color display of our invention and by selecting the "color analysis", the analysis of the color of the teeth will be transferred onto their measured volumes. This measurement will be done by colorimetry using 3 or 4 basic LED colors (RGB). Being able to have different LED colors, thus several wavelengths, we can approximate a continuous spectrum, without the risk of disturbing an structured active light. We will have a spectro-colorimetric analysis independent from the metamerism.

Advantageously and according to the invention, the LEDs can also play an important role in the correlation of the successive pictures (Figure 12) (85). Indeed, we know that there are methods based on the correlations of the pictures with marks placed in the measured environment or using the similarity found in the diagram itself, or even working on the fuzzy edge of the pictures. All these systems are complex, because they require either placing spherical marks in the area, which operation is complex at clinical level, or identifying areas often without any relief or with too an even condition of the surface.

Scanning with LEDs having a known wavelength with a color 3D imaging permits to simplify and automate this process. Indeed, a simple colored line or the sticking of a mark can be detected and displayed automatically if we have taken care to use a marking using a color that is complementary, identical, additive or subtractive of the wavelength of one (or several) of the scanning LEDs (79). The detection will thus occur through a simple chromatic highlighting of any mark whatsoever. This marking, which is always in the same position on the object, regardless of the angle or zoom of our optical impressions, will serve as a correlation reference.

Advantageously and according to the same principle in our invention, it will be possible to track the mandibular movements by placing our camera in the vestibular area of the jaws of the mouth. We draw red-color lines on the upper jaw bone and the lower jaw bone, and this is only a non-restrictive example, and then we film the movements of these two jaw bones, in a vestibular view, from the start to the end of the movement. The camera takes pictures in which a scatter diagram moves (the lower jaw bone) relative to the other scatter diagram (the upper jaw bone, which is in principle considered immobile). Since our marking belongs independently to each jaw bone, our system will only track the movement of the colored markings, highlighted when the red LED is lit (in our example and this is only an example). Since this same marking exists at the time the optical impression made separately of the upper jaw bone and the lower jaw bone, the correlation software will use this colored marking not only for correlating the images of each one of the jaw bones, but also for displaying the movements depending on the fourth dimension, the time.

This operation can be performed without using a marker, but only through the identification of the scatter diagram common to the upper and lower jaw bones.

It is also possible to measure the position in occlusion and the displacement of an arch with respect to the other one. To this end, the camera is positioned laterally, with clenched teeth, in order to take the coordinates of the points visible on both
5 arches, usually located on the labial surfaces of the teeth.

Since the points detected in the vestibular pictures are common to the individual pictures of each of the arches, it is possible to correlate all the points of both arches taken individually and to so have all the points in occlusion, including the
10 inaccessible areas in the vestibular view, with clenched teeth.

We then have three types of point files, the file of the upper arch, that of the lower arch and that of the two arches in occlusion referred to as static occlusion.

If we position the camera for a vestibular view, with clenched
15 teeth, and we ask the patient to move his teeth, we will have a fourth file corresponding to the temporal displacement of the upper arch with respect to the lower arch. It is enough to follow over time the movement of the points identified in the vestibular view. This will provide the information on the
20 dynamic movements in occlusion.

This same operation can be performed using a laboratory patch or articulator. The camera will follow the displacement of the vestibular points detected on the plaster models placed on the articulator.

25 Starting from this static analysis of the occlusion, it is possible to position our virtual models in a virtual articulator as introduced in Chambéry in 1985 and to follow the dynamic movements by adjusting the essential data, which are the condylar inclination, the Bennett angle and other essential
30 information given by a face-bow.

We can advantageously use the points of the 3D analysis resulting from our invention in order to properly position the virtual model on the virtual articulator and/or we can use the marking points as defined in our patent EP 0373077 or our patent application EP 93.913173.6.

Based on this static and dynamic occlusion measurement, we can use the method described in our patent EP 0369908 (US 5,143,086) "device for measuring and analyzing the movements of the human body or part thereof". This will allow us to have all the clinical information necessary for a good analysis of the patient's occlusion.

Likewise and advantageously in our invention, the same principle of the intervention of time in following the movements will be applied for measuring the pressure on the pathologies that can be found in the mouth. Indeed, we know that a pathology can i.a. be identified by its reaction to the pressure (more or less rapid return to its original position). By following the "physical" reaction over time of the optical impression of our excrescence, we will be able to assist in diagnosing. In fact, we took care, as can be seen in drawing 6a (69) to permit the passing-through of an instrument to perform this action, without it being an obligation of course.

The light is intended only to illuminate the scene, in order to promote the signal-noise ratio. It would indeed be possible to perform a measurement without light illuminating the surface being measured, but working in dark areas like the inside of the mouth requires an ambient light chosen as close as possible to daylight, or using a light having known spectral characteristics, so that the color rendering can be analyzed for extracting from same the characteristic data of the analyzed tissues.

This unstructured light also permits, as we already said, to work with the lighting of the dentist's room or the laboratory.

Likewise, as we can see, by selecting certain wavelengths emitted by the LEDs present around the reading window and by increasing their frequencies or/and their intensities, we can place on a 3D image the display of certain anatomies or pathologies located at a small depth. Knowledge of the volume provides an indication of the positioning of this pathological limit, which permits to predict and display its evolution. This is also true for the fluorescence reactions of some tissues to blue or UV radiation. The fluorescence appears not only at the surface, but also in the depth of the pathology, which helps us to provide assistance for the therapy to be applied (exeresis of pathological tissue). Knowing the penetration of such or such radiation, it is possible to assess the extent and depth with respect to the actual 3D surface being analyzed.

Finally, and this is not restrictive, having two 2D images for constructing the 3D image permits us, in real time, to switch our vision without any modification of the camera to 2D color displays like all the cameras nowadays available on the market of dentistry. Therefore, since it does not use structured-light projection, our camera can perform all presently known functions, including zoom effects, but also the applications of color diagnosis on 2D images, such as the detections of caries by fluorescence in green, blue or UV (500 to 300 nm) radiations or visualizations in red and IR radiation (600 to 900 nm), depending on the LEDs that we have emulated in the analysis.

Advantageously, and this remains a very interesting point of our invention, it is possible to work in 2D color starting from 3D views. This can be done in two different ways:

- Since we use daylight (79), without projection of frames or other structured light, the display screen (5) in our control during the recording of pictures (78) allows us to use this optical impression camera as a simple 2D camera, which significantly limits the practitioners' cost of investment.

- We can also perform this 2D display, after digital processing and highlighting of the pathological areas by scanning with LEDs of specific wavelengths. This technique is obviously possible only starting from 3D images.

5 This same zoom effect in color picture or the emulations can be performed on the 3D images. It is obvious that the transition from color to grayscale will only be an offset function present in the software controlling the processing of images resulting from the operation of the camera.

10 It clearly appears from the foregoing description that the present invention fully solves the the problems set forth, in that it provides a real answer for optimizing 3D color and dynamic dental reading (in time) and the pathological analysis of skin pathologies at particularly low cost due to a concept
15 that can be fixed during the manufacturing phase. It also clearly appears from this description that it permits to solve the basic problems, such as the control of the clinical procedure, especially since no alternative has been provided. It is obvious that the invention is not limited to one form of
20 implementation of this method, nor to only the embodiments of the device for implementing this method as written above by way of an example. On the contrary, it encompasses all variants of implementation and embodiment. Thus, it is possible, in particular, to measure the oral pathologies, irrespective of
25 their being related to hard tissue or soft tissue.

CLAIMS

1) Three-dimensional measuring device used in the dental field and aimed at measuring in the absence of projection of active or structured light, comprising means for capturing images as well as data-processing means for said images, wherein said image-capturing means (38, 39) consist of means designed capable of permitting to capture simultaneously, or almost simultaneously, at least two images, one of which is totally or partially included in the other one, said included image describing a narrower field than that of the other one, and having a higher accuracy than that of the other one.

2) Three-dimensional measuring device according to claim 1, wherein the image-capturing means consist of at least two electronic image sensors, one of which (38) viewing a wide field with average accuracy and the other one (39) a narrower field with higher accuracy totally or partially included in said wide field, said sensors being associated with optical systems.

3) Three-dimensional measuring device according to claim 2, wherein the optical systems associated with the sensors have different focal lengths in order to permit two different levels of accuracy.

4) Three-dimensional measuring device according to claim 3, wherein the sensors consist of color or monochromatic CCD or CMOS electronic sensors.

5) Three-dimensional measuring device according to any of claims 1 to 4, wherein it comprises in addition an accelerometer/gyro/3D magnetometer (52) capable of providing a general and continuous information on the spatial position of the image-capturing means.

6) Three-dimensional measuring device according to any of claims 1 to 5, wherein it comprises: a central management and analog/digital data conversion unit,

- a data transmission via cable, telephone or wireless,

5 - a hardware system for additional processing, dialog/display with the operator, data transmission and storage,

- a power-supply card capable of operating on USB or on battery (e.g. AC/DC).

7) Three-dimensional measuring device according to any of
10 claims 1 to 6, wherein it comprises a passive and unstructured lighting by means of LEDs of one or more wavelengths permitting to measure specular or Lambertian regular surfaces, and having unstructured light, but with the specific characteristics in terms of purity (consistent or not), type (color) and intensity
15 (power) for the function of diagnosis on a 3D image, transferred onto the 3D surfaces.

8) Three-dimensional measuring device according to claim 7, wherein the LEDs are of a predefined wavelength.

9) Three-dimensional measuring device according to any of
20 claims 2 to 8, wherein one of the sensors is designed capable of indicating the general information on the field depth, so that the focal length of the other sensor is pre-positioned in a region close to reality analyzed by the first sensor.

10) Three-dimensional measuring device according to any of
25 claims 1 to 9, wherein the means for capturing images in the narrowest field with higher accuracy is associated with a displacement means permitting it to quickly scan the entire field covered by the other capturing means.

11) Three-dimensional measuring device according to any of
30 claims 1 to 10, wherein the means for capturing images in the

narrowest field with higher accuracy is associated with a variable zoom.

12) Three-dimensional measuring device according to any of claims 1 to 11, wherein it comprises means for projecting at least one circle of colored light surrounding the field of the included image, and/or the field of the other image.

13) Three-dimensional measuring device according to any of claims 1 to 12, wherein it comprises a flash system with very fast pulsing LEDs.

14) Three-dimensional measuring device according to any of claims 1 to 13, wherein the optical systems include liquid-type lenses.

15) Three-dimensional measuring device according to any of claims 1 to 13, wherein the optical systems comprise lenses of glass or molded glass/plastic with a pupil on the input face, associated with a micro-motor for adjusting the field depth.

16) Three-dimensional measuring device according to any of claims 1 to 13, wherein the optical systems comprise so-called "free-form" thermoplastic lenses comprised of a flat top surrounded by asymmetric facets.

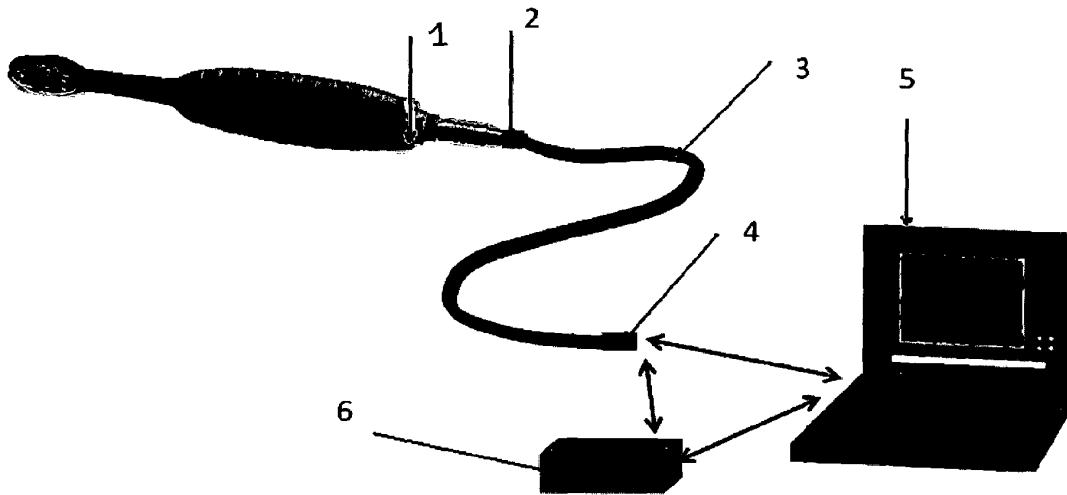

Figure 1a

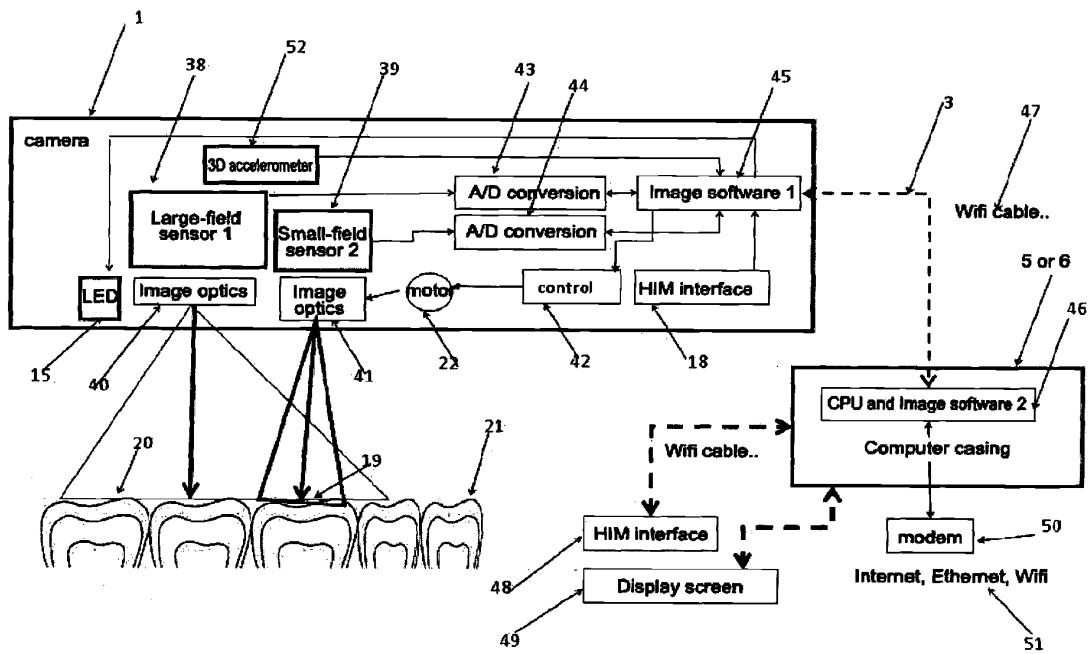

Figure 1b

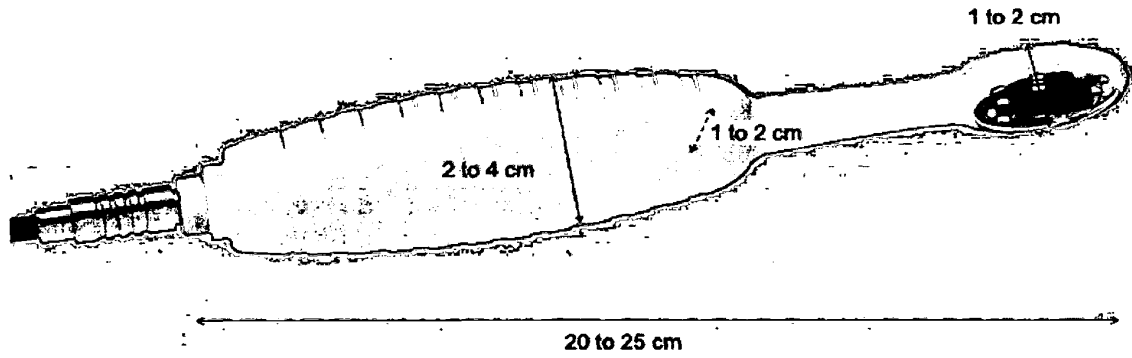

Figure 2

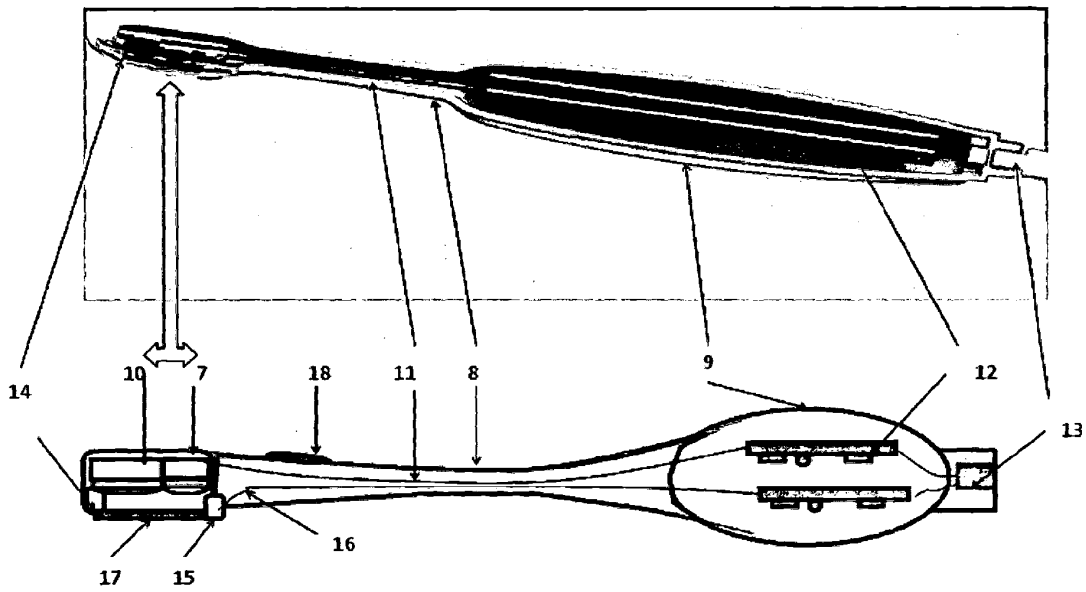

Figure 3

3/13

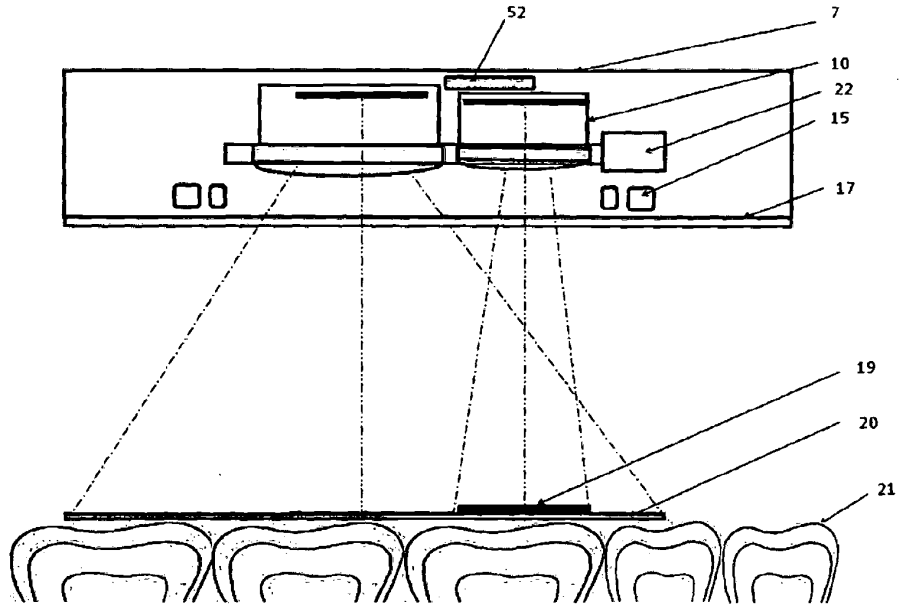
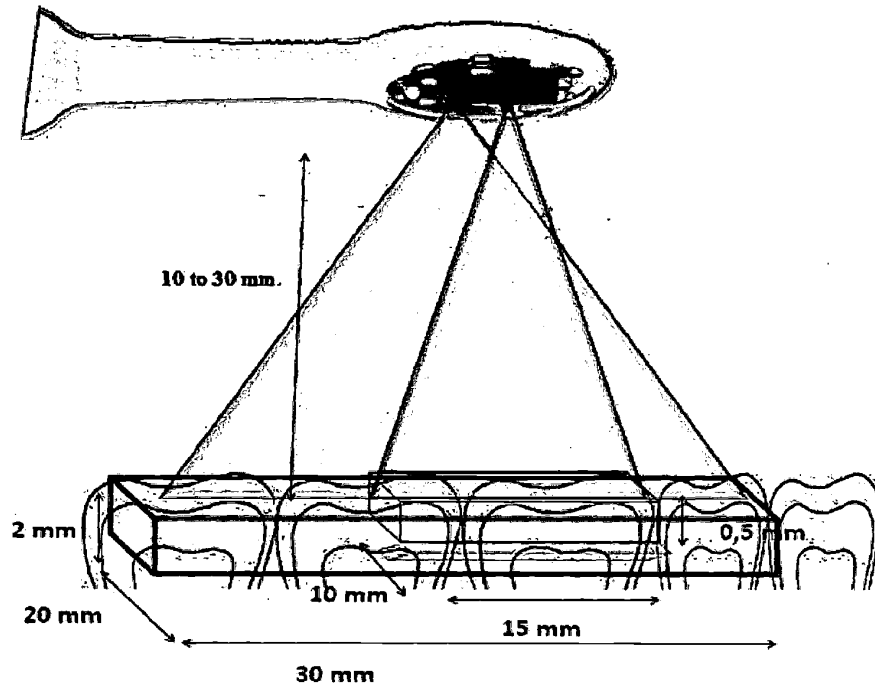

Figure 4

Figure 5



SUBSTITUTE SHEET (RULE 26)

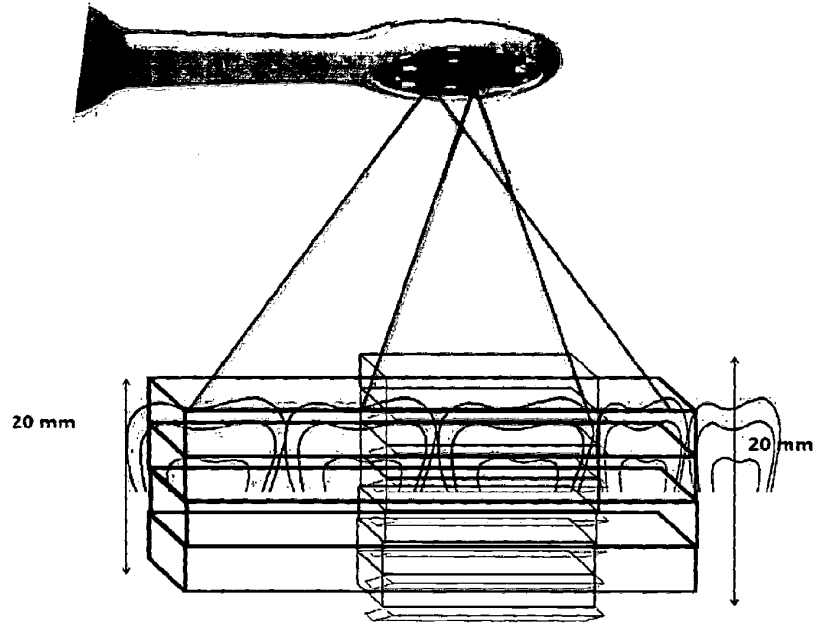

Figure 6

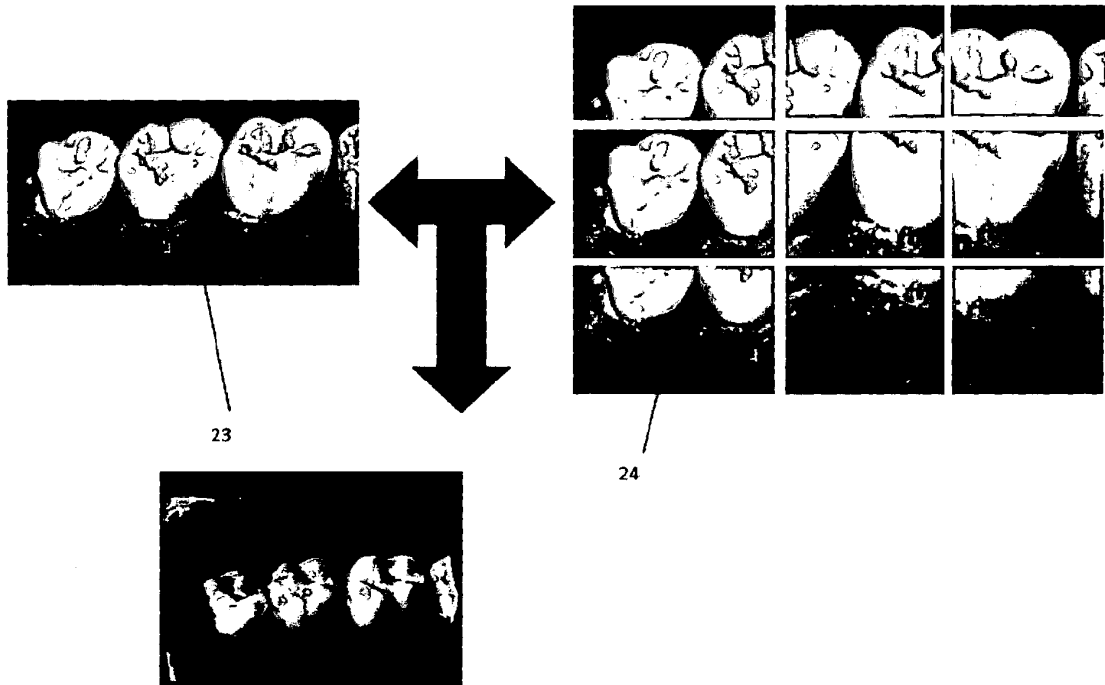

Figure 7

SUBSTITUTE SHEET (RULE 26)

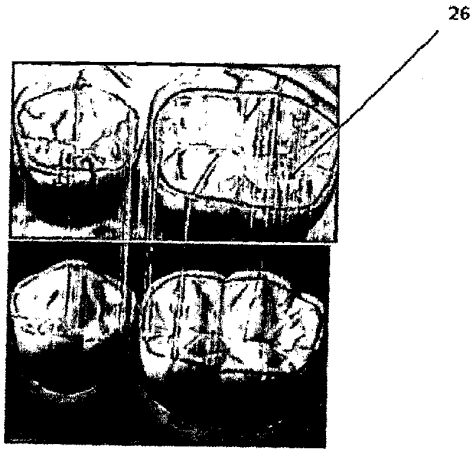

Figure 8a

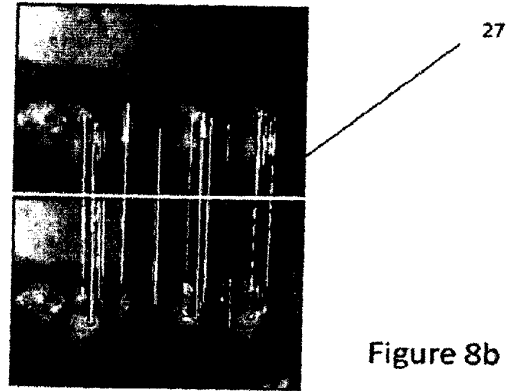

Figure 8b

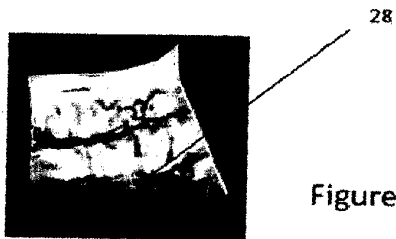

Figure 8c

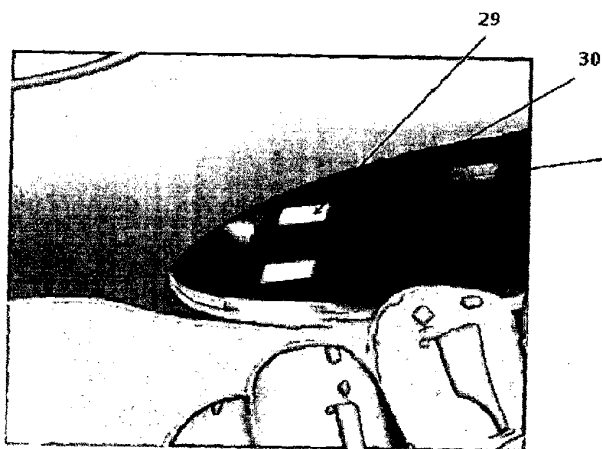

Figure 9a

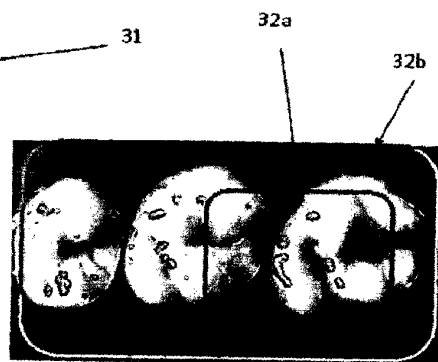
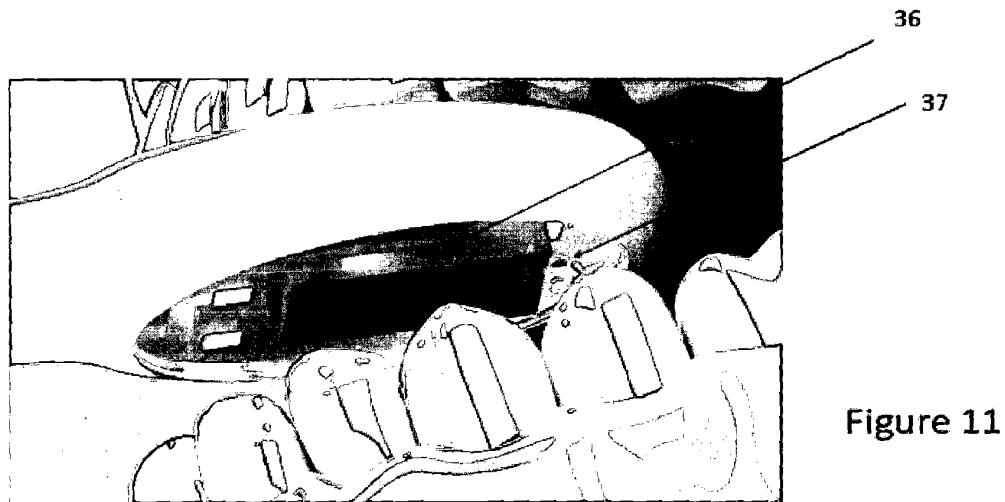
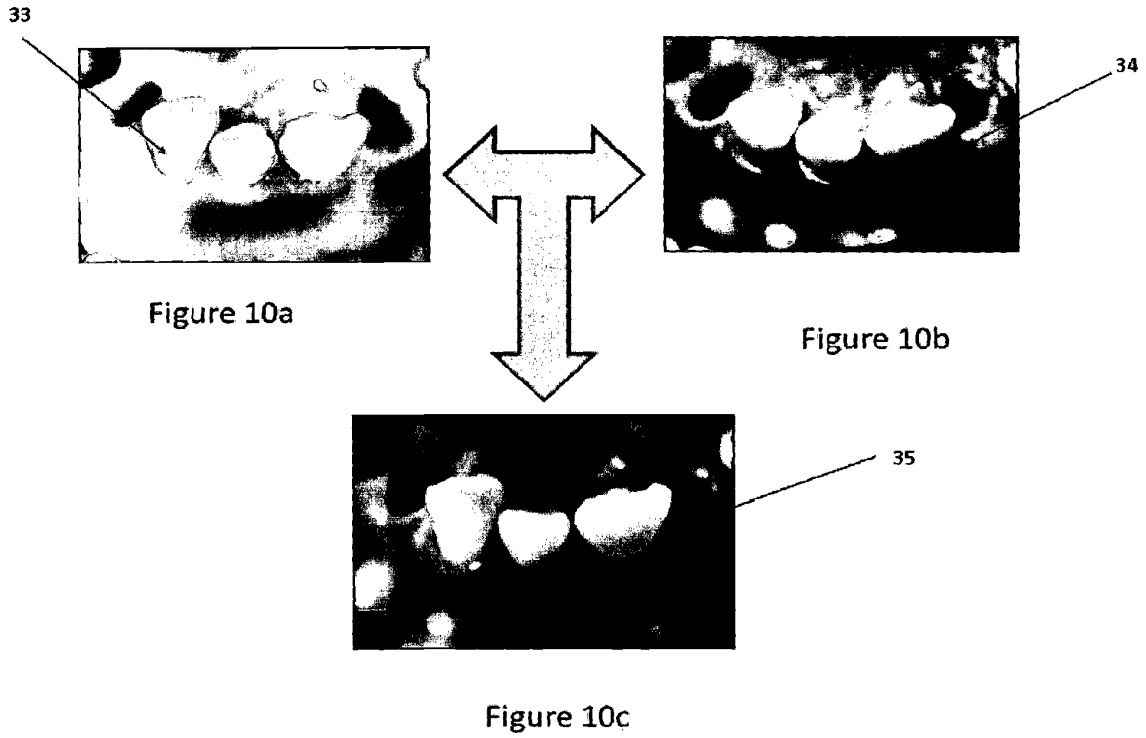

Figure 9b

SUBSTITUTE SHEET (RULE 26)

6/13



SUBSTITUTE SHEET (RULE 26)

General diagram

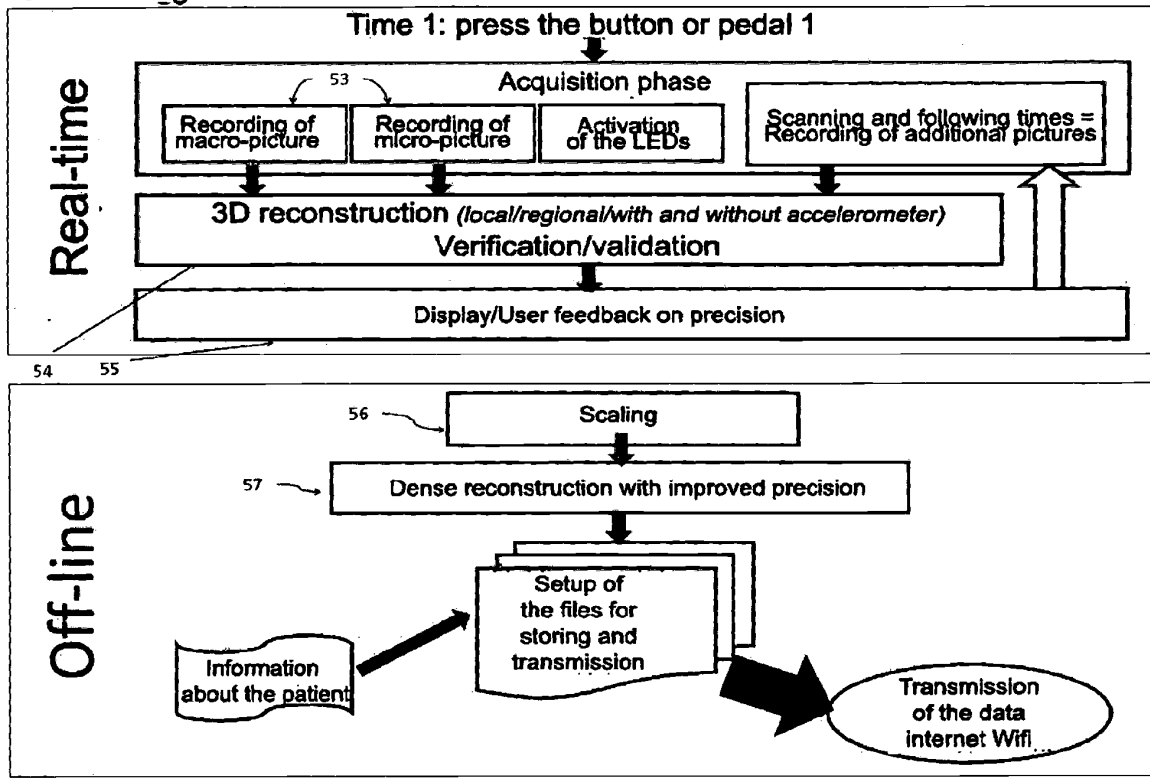

Figure 12

Strategy of integration of recording of micro- and macro-pictures
 CASE 1 : 2 cameras, no accelerometer

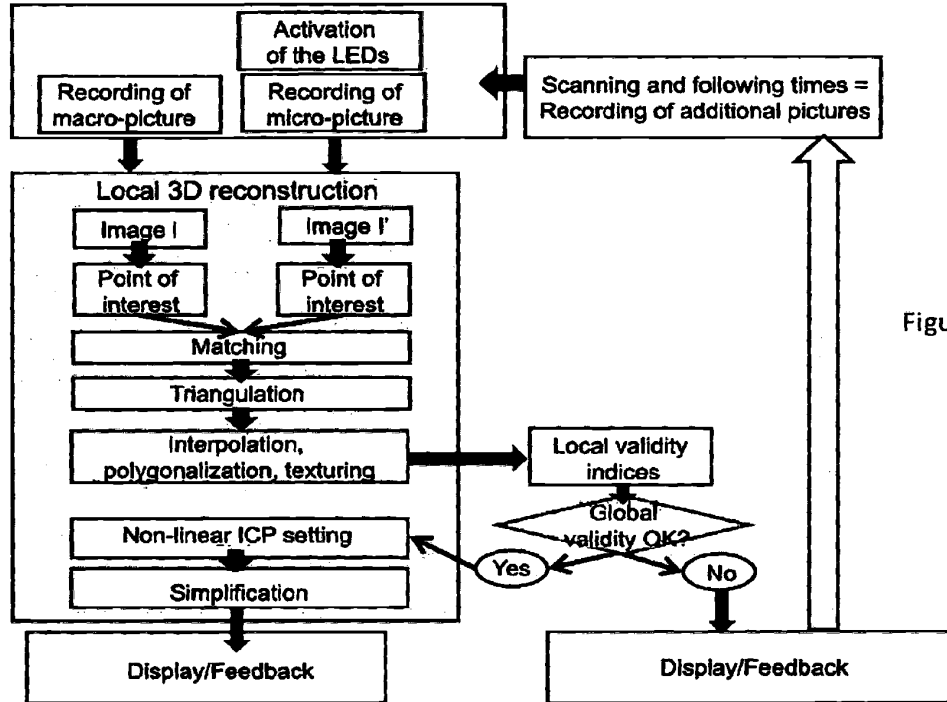

Figure 13a

Strategy of integration of recording of micro- and macro-picture
CASE 2 : with accelerometer and in regional reconstruction

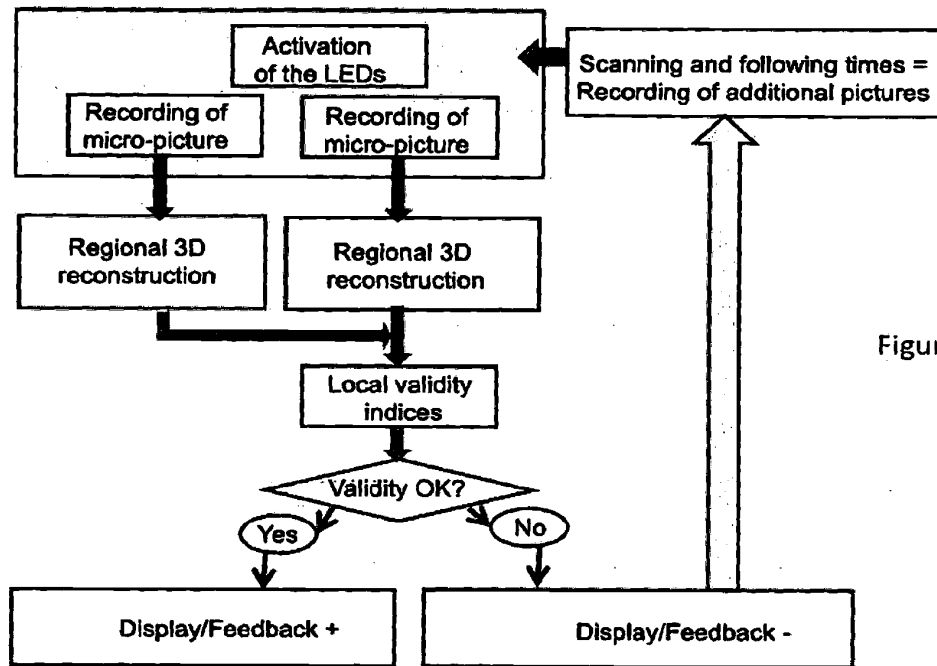

Figure 13b

Figure 13b

Strategy of integration of recording of micro- and macro-picture
CASE 3 : with accelerometer and in regional reconstruction

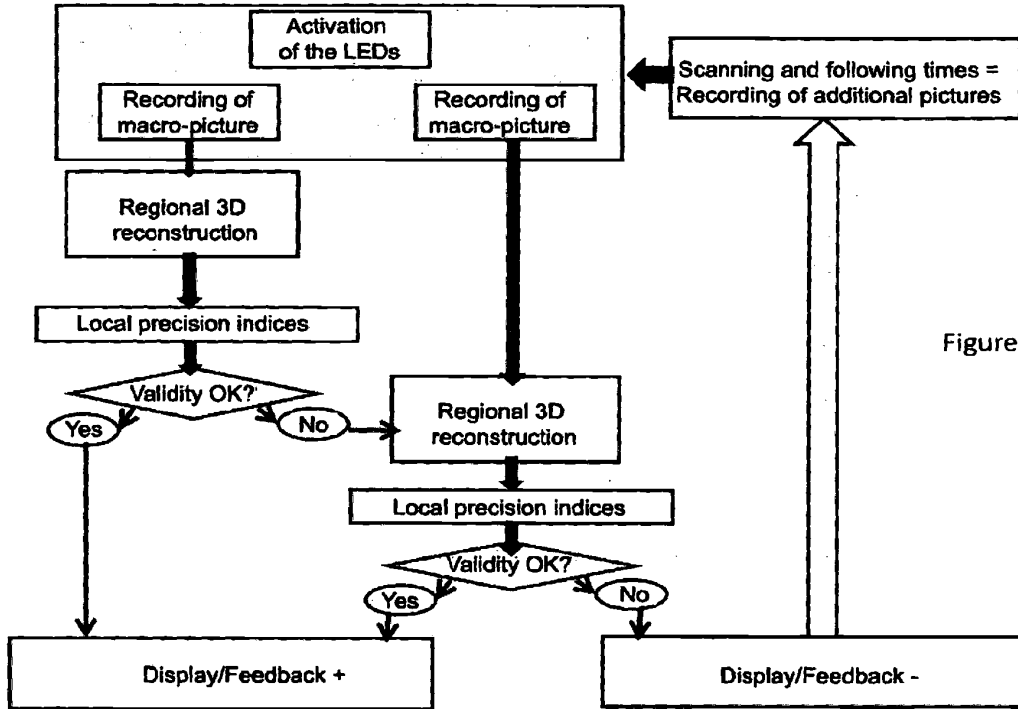
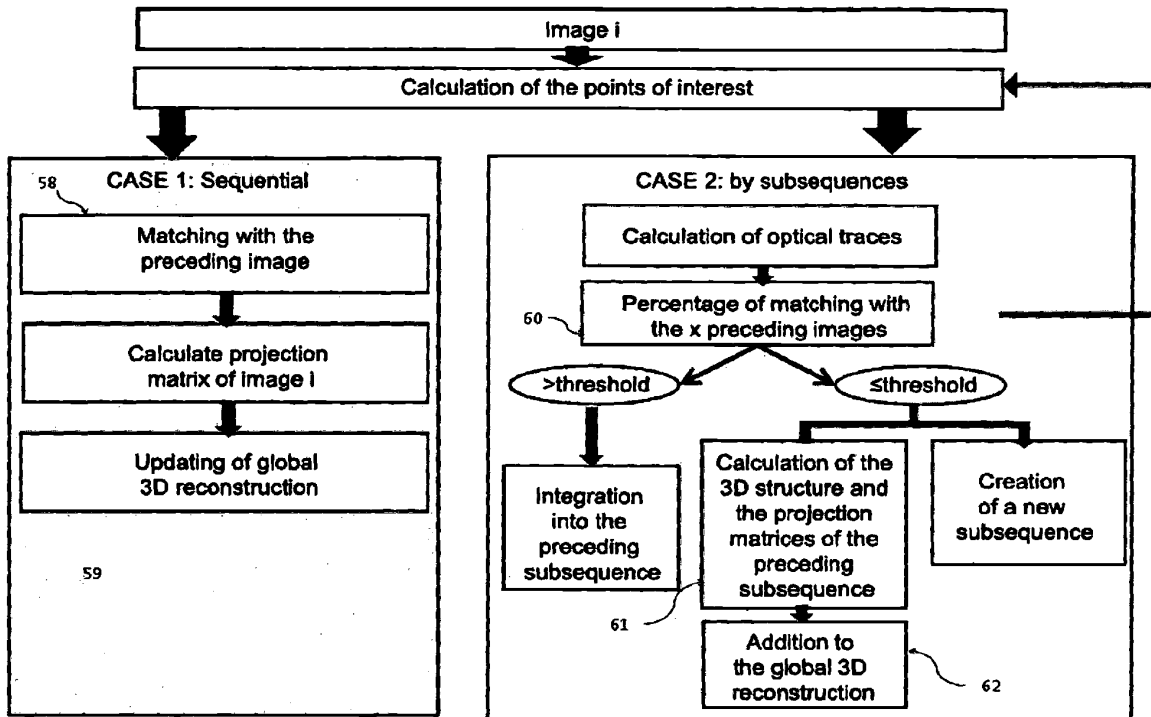

Figure 13c

Regional 3D reconstruction

Figure 14



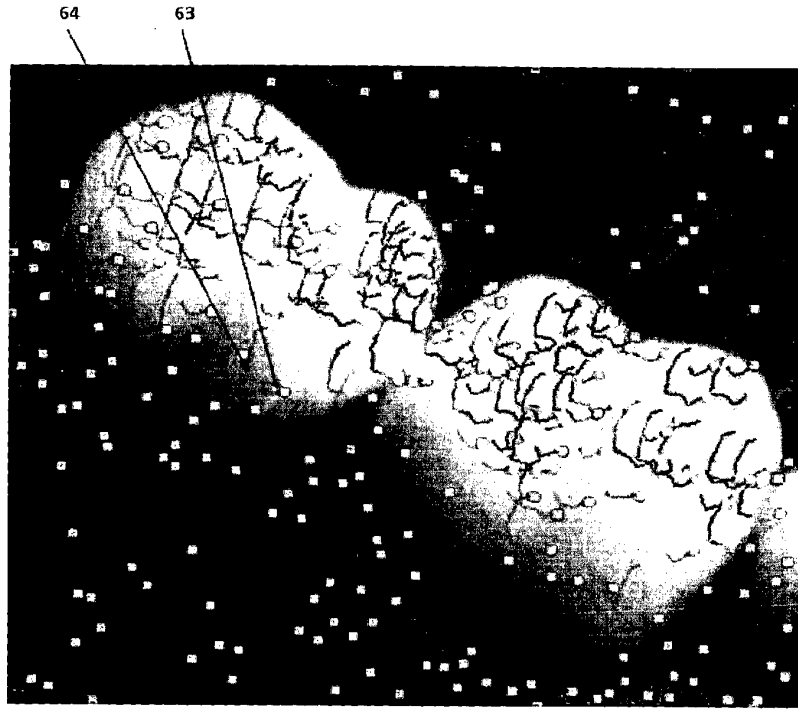
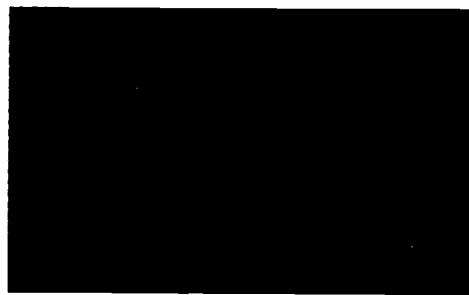

Figure 15

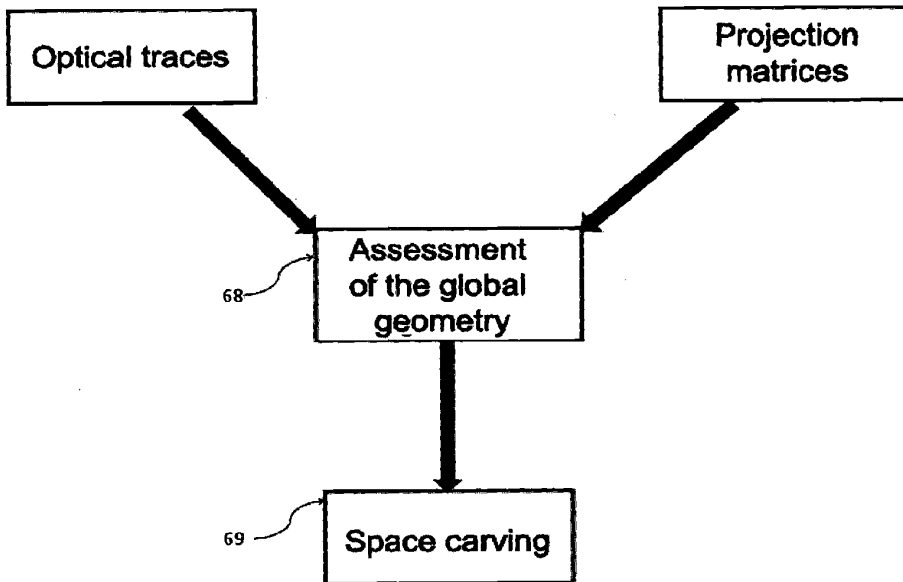

Figure 16



SUBSTITUTE SHEET (RULE 26)

Figure 17



INTERNATIONAL SEARCH REPORT

International application No PCT/IB2012/001777
--

A. CLASSIFICATION OF SUBJECT MATTER
 INV. A61B1/24 A61B5/107 A61B1/00 A61B5/06
 ADD. A61B1/05 A61B1/06 A61C9/00

According to International Patent Classification (IPC) or to both national classification and IPC

B. FIELDS SEARCHED

Minimum documentation searched (classification system followed by classification symbols)
A61B

Documentation searched other than minimum documentation to the extent that such documents are included in the fields searched

Electronic data base consulted during the international search (name of data base and, where practicable, search terms used)

EPO-Internal

C. DOCUMENTS CONSIDERED TO BE RELEVANT

Category*	Citation of document, with indication, where appropriate, of the relevant passages	Relevant to claim No.
X	DE 10 2009 026248 A1 (DEGUDENT GMBH [DE]) 27 January 2011 (2011-01-27) figure 3 paragraphs [0002], [0013], [0030], [0031]	1-16
A	----- US 2010/165080 A1 (YAMAGUCHI HIROSHI [US] ET AL) 1 July 2010 (2010-07-01) paragraphs [0039], [0050] - [0054]	1-3,6
A	----- WO 98/11815 A1 (KAISER ELECTRO OPTICS INC [US]) 26 March 1998 (1998-03-26) figure 2 page 5, lines 1-18 page 7, line 34 - page 8, line 12 ----- -/--	1,2

Further documents are listed in the continuation of Box C. See patent family annex.

* Special categories of cited documents :

"A" document defining the general state of the art which is not considered to be of particular relevance	"T" later document published after the international filing date or priority date and not in conflict with the application but cited to understand the principle or theory underlying the invention
"E" earlier application or patent but published on or after the international filing date	"X" document of particular relevance; the claimed invention cannot be considered novel or cannot be considered to involve an inventive step when the document is taken alone
"L" document which may throw doubts on priority claim(s) or which is cited to establish the publication date of another citation or other special reason (as specified)	"Y" document of particular relevance; the claimed invention cannot be considered to involve an inventive step when the document is combined with one or more other such documents, such combination being obvious to a person skilled in the art
"O" document referring to an oral disclosure, use, exhibition or other means	"&" document member of the same patent family
"P" document published prior to the international filing date but later than the priority date claimed	

Date of the actual completion of the international search 4 December 2012	Date of mailing of the international search report 12/12/2012
---	---

Name and mailing address of the ISA/ European Patent Office, P.B. 5818 Patentlaan 2 NL - 2280 HV Rijswijk Tel. (+31-70) 340-2040, Fax: (+31-70) 340-3016	Authorized officer Albrecht, Ronald
--	---

INTERNATIONAL SEARCH REPORT

International application No

PCT/IB2012/001777

C(Continuation). DOCUMENTS CONSIDERED TO BE RELEVANT		
Category*	Citation of document, with indication, where appropriate, of the relevant passages	Relevant to claim No.
A	DE 10 2008 031054 A1 (KALTENBACH & VOIGT [DE]) 16 July 2009 (2009-07-16) paragraphs [0027], [0030] - [0032], [0053] -----	6-8,11, 15
A	DE 196 36 354 A1 (RUBBERT RUEDGER DIPL ING [DE]) 5 March 1998 (1998-03-05) column 5, line 38 - line 51 -----	13
A	EP 2 213 223 A1 (PANASONIC CORP [JP]) 4 August 2010 (2010-08-04) paragraph [0029] -----	7,8,14
A	US 2009/227875 A1 (CAO DENSEN [US] ET AL) 10 September 2009 (2009-09-10) paragraphs [0018] - [0020] claims 6,9 -----	15
A	EP 1 600 804 A1 (STM MEDTECH STARNBERG [DE]) 30 November 2005 (2005-11-30) paragraphs [0039] - [0042] -----	16

INTERNATIONAL SEARCH REPORT

Information on patent family members

International application No

PCT/IB2012/001777

Patent document cited in search report	Publication date	Patent family member(s)	Publication date
DE 102009026248 A1	27-01-2011	CA 2768449 A1 CN 102648390 A DE 102009026248 A1 EP 2457058 A1 US 2012133742 A1 WO 2011009736 A1	27-01-2011 22-08-2012 27-01-2011 30-05-2012 31-05-2012 27-01-2011
US 2010165080 A1	01-07-2010	NONE	
WO 9811815 A1	26-03-1998	US 5846185 A WO 9811815 A1	08-12-1998 26-03-1998
DE 102008031054 A1	16-07-2009	DE 102008031054 A1 EP 2232321 A2 US 2011234781 A1 WO 2009090051 A2	16-07-2009 29-09-2010 29-09-2011 23-07-2009
DE 19636354 A1	05-03-1998	AU 4111397 A CN 1236431 A DE 19636354 A1 EP 0923704 A1 JP 2001501049 A US 2005090749 A1 WO 9810243 A1	26-03-1998 24-11-1999 05-03-1998 23-06-1999 23-01-2001 28-04-2005 12-03-1998
EP 2213223 A1	04-08-2010	CN 101822526 A EP 2213223 A1 JP 2010194296 A KR 20100087629 A US 2010189341 A1	08-09-2010 04-08-2010 09-09-2010 05-08-2010 29-07-2010
US 2009227875 A1	10-09-2009	NONE	
EP 1600804 A1	30-11-2005	DE 102004026004 A1 EP 1600804 A1 JP 2005334647 A US 2005272979 A1	22-12-2005 30-11-2005 08-12-2005 08-12-2005

Electronic Patent Application Fee Transmittal				
Application Number:				
Filing Date:				
Title of Invention:		FOCUS SCANNING APPARATUS RECORDING COLOR		
First Named Inventor/Applicant Name:		Bo ESBECH		
Filer:		Travis Dean Boone/Beverly Caraway		
Attorney Docket Number:		0079124-000111		
Filed as Large Entity				
Filing Fees for U.S. National Stage under 35 USC 371				
Description	Fee Code	Quantity	Amount	Sub-Total in USD(\$)
Basic Filing:				
National Stage Fee	1631	1	280	280
Natl Stage Search Fee - Report provided	1642	1	480	480
National Stage Exam - all other cases	1633	1	720	720
Pages:				
Claims:				
Claims in excess of 20	1615	11	80	880
Miscellaneous-Filing:				
Oath/Decl > 30 Mos From 371 commencement	1617	1	140	140

Description	Fee Code	Quantity	Amount	Sub-Total in USD(\$)
Petition:				
Patent-Appeals-and-Interference:				
Post-Allowance-and-Post-Issuance:				
Extension-of-Time:				
Miscellaneous:				
Total in USD (\$)				2500

Electronic Acknowledgement Receipt

EFS ID:	23041354
Application Number:	14764087
International Application Number:	PCT/EP2014/052842
Confirmation Number:	6247
Title of Invention:	FOCUS SCANNING APPARATUS RECORDING COLOR
First Named Inventor/Applicant Name:	Bo ESBECH
Customer Number:	21839
Filer:	Travis Dean Boone/Beverly Caraway
Filer Authorized By:	Travis Dean Boone
Attorney Docket Number:	0079124-000111
Receipt Date:	28-JUL-2015
Filing Date:	
Time Stamp:	16:51:41
Application Type:	U.S. National Stage under 35 USC 371

Payment information:

Submitted with Payment	yes
Payment Type	Credit Card
Payment was successfully received in RAM	\$2500
RAM confirmation Number	3499
Deposit Account	
Authorized User	

The Director of the USPTO is hereby authorized to charge indicated fees and credit any overpayment as follows:

File Listing:					
Document Number	Document Description	File Name	File Size(Bytes)/ Message Digest	Multi Part /.zip	Pages (if appl.)
1	Application Data Sheet	WebADS.pdf	146998 11388c954d80b6f38f267d97ed2a7644713e0c04	no	7
Warnings:					
Information:					
2	Transmittal of New Application	TL.pdf	205307 f2c716f052e8641fb8aec67ee95fdbb1509a653	no	3
Warnings:					
Information:					
3	Authorization for Extension of Time all replies	GA.pdf	32682 1d872eabf92a8e055515cdf8abc57215d3ed054b	no	1
Warnings:					
Information:					
4	Power of Attorney	POA.pdf	149062 a7c054a52c0b4dc636060ba7f4046582b3d1a5f7	no	2
Warnings:					
Information:					
5		PA.pdf	417808 bdc27dcad22a8e5bfbaf8acc69e8346d9822ceb1	yes	11
	Multipart Description/PDF files in .zip description				
	Document Description		Start	End	
	Preliminary Amendment		1	1	
	Specification		2	2	
	Claims		3	10	
	Applicant Arguments/Remarks Made in an Amendment		11	11	
Warnings:					
Information:					

6	Specification	SUB_SPEC.pdf	179752 aeb08c43c08c76045b4f68ed189dcecb8087861	no	34
Warnings:					
Information:					
7	Applicant Arguments/Remarks Made in an Amendment	MARKED-UP_SPEC.pdf	180360 1a709b60015ea274998d7d784932c4d087ae6ed4	no	34
Warnings:					
Information:					
8		SPEC.pdf	6492819 052d568a35c7d84fa62288a52a75d72d4b83b58	yes	40
	Multipart Description/PDF files in .zip description				
	Document Description		Start	End	
	Specification		1	33	
	Claims		34	39	
	Abstract		40	40	
Warnings:					
Information:					
9	Drawings-only black and white line drawings	DRAW.pdf	169153 242ce85169f0144bd731b1344b66db921de550b	no	4
Warnings:					
Information:					
10	Documents submitted with 371 Applications	301.pdf	127610 b854aeece87324771539bd9d19b3c2fc102d7a21d	no	1
Warnings:					
Information:					
11	Documents submitted with 371 Applications	304.pdf	141858 e57aec389edbe7c1b906a38ff6c26a7f8558409e	no	1
Warnings:					
Information:					
12	Documents submitted with 371 Applications	308.pdf	287628 a89e56ff9a5d0d43e0f8870d09a51eed3abffce	no	2
Warnings:					
Information:					

13	Transmittal Letter	IDS.pdf	32300 b057e6e08d40e73b98d697ce1459df0450d ba5af	no	1
Warnings:					
Information:					
14	Information Disclosure Statement (IDS) Form (SB08)	1449.pdf	34610 3ac501e7ed8dd4e9114eeffbf0caf77db09 259	no	1
Warnings:					
Information:					
This is not an USPTO supplied IDS fillable form					
15	Other Reference-Patent/App/Search documents	210.pdf	503217 d2f687cfee3553689016f07a8acfe0a0d282 bbf8	no	5
Warnings:					
Information:					
16	Foreign Reference	REF1_WO2010145669.pdf	9709569 52834f33c6023e501df6614574eeee3aa804 2695	no	97
Warnings:					
Information:					
17	Foreign Reference	REF2_WO2012083967.pdf	9435449 64d4e93cc15e31a346b7ce151e8763fb30e d963d	no	100
Warnings:					
Information:					
18	Foreign Reference	REF3_JP2004029373.pdf	1446284 a70148cca9b9c91d85a7bea7412cfb85f8eb ea32	no	17
Warnings:					
Information:					
19	Foreign Reference	REF4_EP2241248.pdf	2664143 5a497793c77a0e4024e1f1514200a66186a 61bc7	no	27
Warnings:					
Information:					
20	Foreign Reference	REF5_WO2013008097.pdf	12292113 44da4cfee89320cb6f462836d8f8be4a35b8 b48a2	no	84
Warnings:					
Information:					
21	Fee Worksheet (SB06)	fee-info.pdf	38486 150baefac7a696ec20ecdb7e9f71f649d94 729d	no	2

Warnings:	
Information:	
Total Files Size (in bytes):	44687208
<p>This Acknowledgement Receipt evidences receipt on the noted date by the USPTO of the indicated documents, characterized by the applicant, and including page counts, where applicable. It serves as evidence of receipt similar to a Post Card, as described in MPEP 503.</p> <p><u>New Applications Under 35 U.S.C. 111</u> If a new application is being filed and the application includes the necessary components for a filing date (see 37 CFR 1.53(b)-(d) and MPEP 506), a Filing Receipt (37 CFR 1.54) will be issued in due course and the date shown on this Acknowledgement Receipt will establish the filing date of the application.</p> <p><u>National Stage of an International Application under 35 U.S.C. 371</u> If a timely submission to enter the national stage of an international application is compliant with the conditions of 35 U.S.C. 371 and other applicable requirements a Form PCT/DO/EO/903 indicating acceptance of the application as a national stage submission under 35 U.S.C. 371 will be issued in addition to the Filing Receipt, in due course.</p> <p><u>New International Application Filed with the USPTO as a Receiving Office</u> If a new international application is being filed and the international application includes the necessary components for an international filing date (see PCT Article 11 and MPEP 1810), a Notification of the International Application Number and of the International Filing Date (Form PCT/RO/105) will be issued in due course, subject to prescriptions concerning national security, and the date shown on this Acknowledgement Receipt will establish the international filing date of the application.</p>	

Application Data Sheet 37 CFR 1.76		Attorney Docket Number	0079124-000111
		Application Number	
Title of Invention	FOCUS SCANNING APPARATUS RECORDING COLOR		
<p>The application data sheet is part of the provisional or nonprovisional application for which it is being submitted. The following form contains the bibliographic data arranged in a format specified by the United States Patent and Trademark Office as outlined in 37 CFR 1.76. This document may be completed electronically and submitted to the Office in electronic format using the Electronic Filing System (EFS) or the document may be printed and included in a paper filed application.</p>			

Secrecy Order 37 CFR 5.2

- Portions or all of the application associated with this Application Data Sheet may fall under a Secrecy Order pursuant to 37 CFR 5.2(Paper filers only. Applications that fall under Secrecy Order may not be filed electronically.)

Inventor Information:

Inventor 1					<input type="button" value="Remove"/>
Legal Name					
Prefix	Given Name	Middle Name	Family Name	Suffix	
	Bo		ESBECH		
Residence Information (Select One) <input type="radio"/> US Residency <input checked="" type="radio"/> Non US Residency <input type="radio"/> Active US Military Service					
City	Gentofte	Country of Residence	DK		
Mailing Address of Inventor:					
Address 1	Dalvej 25				
Address 2					
City	Gentofte	State/Province	OT		
Postal Code	DK-2820	Country	DK		
Inventor 2					<input type="button" value="Remove"/>
Legal Name					
Prefix	Given Name	Middle Name	Family Name	Suffix	
	Christian	ROMER	ROSBERG		
Residence Information (Select One) <input type="radio"/> US Residency <input checked="" type="radio"/> Non US Residency <input type="radio"/> Active US Military Service					
City	Bronshoj	Country of Residence	DK		
Mailing Address of Inventor:					
Address 1	Hampeland 14				
Address 2					
City	Bronshoj	State/Province	OT		
Postal Code	DK-2700	Country	DK		
Inventor 3					<input type="button" value="Remove"/>
Legal Name					

Application Data Sheet 37 CFR 1.76		Attorney Docket Number	0079124-000111	
		Application Number		
Title of Invention	FOCUS SCANNING APPARATUS RECORDING COLOR			
Prefix	Given Name	Middle Name	Family Name	Suffix
	Mike		VAN DER POEL	
Residence Information (Select One) <input type="radio"/> US Residency <input checked="" type="radio"/> Non US Residency <input type="radio"/> Active US Military Service				
City	Rodovre	Country of Residence	i DK	
Mailing Address of Inventor:				
Address 1	Raevebakken 35B			
Address 2				
City	Rodovre	State/Province	OT	
Postal Code	DK-2610	Country	i DK	
Inventor	4			<input type="button" value="Remove"/>
Legal Name				
Prefix	Given Name	Middle Name	Family Name	Suffix
	Rasmus		KJAER	
Residence Information (Select One) <input type="radio"/> US Residency <input checked="" type="radio"/> Non US Residency <input type="radio"/> Active US Military Service				
City	Kobenhavn K	Country of Residence	i DK	
Mailing Address of Inventor:				
Address 1	Norre Sogade 21, 1			
Address 2				
City	Kobenhavn K	State/Province	OT	
Postal Code	DK-1370	Country	i DK	
Inventor	5			<input type="button" value="Remove"/>
Legal Name				
Prefix	Given Name	Middle Name	Family Name	Suffix
	Michael		VINTHER	
Residence Information (Select One) <input type="radio"/> US Residency <input checked="" type="radio"/> Non US Residency <input type="radio"/> Active US Military Service				
City	Kobenhavn S	Country of Residence	i DK	
Mailing Address of Inventor:				
Address 1	Tom Kristensens Vej 34, 4tv			
Address 2				
City	Kobenhavn S	State/Province	OT	
Postal Code	DK-2300	Country	i DK	

Application Data Sheet 37 CFR 1.76		Attorney Docket Number	0079124-000111
		Application Number	
Title of Invention	FOCUS SCANNING APPARATUS RECORDING COLOR		

Inventor 6					<input type="button" value="Remove"/>
Legal Name					
Prefix	Given Name	Middle Name	Family Name	Suffix	
	Karl-Josef		HOLLENBECK		
Residence Information (Select One) <input type="radio"/> US Residency <input checked="" type="radio"/> Non US Residency <input type="radio"/> Active US Military Service					
City	Copenhagen O	Country of Residence	i	DK	
Mailing Address of Inventor:					
Address 1	Rosenvaengets Hovedvej 6B				
Address 2					
City	Copenhagen O	State/Province	OT		
Postal Code	DK-2100	Country	i	DK	
All Inventors Must Be Listed - Additional Inventor Information blocks may be generated within this form by selecting the Add button.					<input type="button" value="Add"/>

Correspondence Information:

Enter either Customer Number or complete the Correspondence Information section below.	
For further information see 37 CFR 1.33(a).	
<input type="checkbox"/> An Address is being provided for the correspondence information of this application.	
Customer Number	21839
Email Address	
<input type="button" value="Add Email"/> <input type="button" value="Remove Email"/>	

Application Information:

Title of the Invention	FOCUS SCANNING APPARATUS RECORDING COLOR		
Attorney Docket Number	0079124-000111	Small Entity Status Claimed	<input type="checkbox"/>
Application Type			
Subject Matter			
Total Number of Drawing Sheets (if any)	4	Suggested Figure for Publication (if any)	1

Filing By Reference

Only complete this section when filing an application by reference under 35 U.S.C. 111(c) and 37 CFR 1.57(a). Do not complete this section if application papers including a specification and any drawings are being filed. Any domestic benefit or foreign priority information must be provided in the appropriate section(s) below (i.e., "Domestic Benefit/National Stage Information" and "Foreign Priority Information").

For the purposes of a filing date under 37 CFR 1.53(b), the description and any drawings of the present application are replaced by this reference to the previously filed application, subject to conditions and requirements of 37 CFR 1.57(a).

Application Data Sheet 37 CFR 1.76		Attorney Docket Number	0079124-000111
		Application Number	
Title of Invention	FOCUS SCANNING APPARATUS RECORDING COLOR		
Application number of the previously filed application	Filing date (YYYY-MM-DD)	Intellectual Property Authority or Country i	

Publication Information:

Request Early Publication (Fee required at time of Request 37 CFR 1.219)

Request Not to Publish. I hereby request that the attached application not be published under 35 U.S.C. 122(b) and certify that the invention disclosed in the attached application **has not and will not** be the subject of an application filed in another country, or under a multilateral international agreement, that requires publication at eighteen months after filing.

Representative Information:

Representative information should be provided for all practitioners having a power of attorney in the application. Providing this information in the Application Data Sheet does not constitute a power of attorney in the application (see 37 CFR 1.32). Either enter Customer Number or complete the Representative Name section below. If both sections are completed the customer Number will be used for the Representative Information during processing.

Please Select One: Customer Number US Patent Practitioner Limited Recognition (37 CFR 11.9)

Customer Number 21839

Additional Representative Information blocks may be generated within this form by selecting the **Add** button.

Domestic Benefit/National Stage Information:

This section allows for the applicant to either claim benefit under 35 U.S.C. 119(e), 120, 121, or 365(c), or 386(c) or indicate National Stage entry from a PCT application. Providing this information in the application data sheet constitutes the specific reference required by 35 U.S.C. 119(e) or 120, and 37 CFR 1.78.

Prior Application Status			<input type="button" value="Remove"/>
Application Number	Continuity Type	Prior Application Number	Filing Date (YYYY-MM-DD)
	a 371 of international	PCT/EP2014/052842	2014-02-13
Prior Application Status			<input type="button" value="Remove"/>
Application Number	Continuity Type	Prior Application Number	Filing Date (YYYY-MM-DD)
PCT/EP2014/052842	Claims benefit of provisional	61764178	2013-02-13

Additional Domestic Benefit/National Stage Data may be generated within this form by selecting the **Add** button.

Application Data Sheet 37 CFR 1.76		Attorney Docket Number	0079124-000111
		Application Number	
Title of Invention	FOCUS SCANNING APPARATUS RECORDING COLOR		

Foreign Priority Information:

This section allows for the applicant to claim priority to a foreign application. Providing this information in the application data sheet constitutes the claim for priority as required by 35 U.S.C. 119(b) and 37 CFR 1.55. When priority is claimed to a foreign application that is eligible for retrieval under the priority document exchange program (PDX) the information will be used by the Office to automatically attempt retrieval pursuant to 37 CFR 1.55(i)(1) and (2). Under the PDX program, applicant bears the ultimate responsibility for ensuring that a copy of the foreign application is received by the Office from the participating foreign intellectual property office, or a certified copy of the foreign priority application is filed, within the time period specified in 37 CFR 1.55(g)(1).

			<input type="button" value="Remove"/>
Application Number	Country	Filing Date (YYYY-MM-DD)	Access Code (if applicable)
PA 2013 70077	DK	2013-02-13	

Additional Foreign Priority Data may be generated within this form by selecting the **Add** button.

Statement under 37 CFR 1.55 or 1.78 for AIA (First Inventor to File) Transition Applications

This application (1) claims priority to or the benefit of an application filed before March 16, 2013 and (2) also contains, or contained at any time, a claim to a claimed invention that has an effective filing date on or after March 16, 2013.

NOTE: By providing this statement under 37 CFR 1.55 or 1.78, this application, with a filing date on or after March 16, 2013, will be examined under the first inventor to file provisions of the AIA.

Authorization to Permit Access:

Authorization to Permit Access to the Instant Application by the Participating Offices

Application Data Sheet 37 CFR 1.76		Attorney Docket Number	0079124-000111
		Application Number	
Title of Invention	FOCUS SCANNING APPARATUS RECORDING COLOR		

If checked, the undersigned hereby grants the USPTO authority to provide the European Patent Office (EPO), the Japan Patent Office (JPO), the Korean Intellectual Property Office (KIPO), the World Intellectual Property Office (WIPO), and any other intellectual property offices in which a foreign application claiming priority to the instant patent application is filed access to the instant patent application. See 37 CFR 1.14(c) and (h). This box should not be checked if the applicant does not wish the EPO, JPO, KIPO, WIPO, or other intellectual property office in which a foreign application claiming priority to the instant patent application is filed to have access to the instant patent application.

In accordance with 37 CFR 1.14(h)(3), access will be provided to a copy of the instant patent application with respect to: 1) the instant patent application-as-filed; 2) any foreign application to which the instant patent application claims priority under 35 U.S.C. 119(a)-(d) if a copy of the foreign application that satisfies the certified copy requirement of 37 CFR 1.55 has been filed in the instant patent application; and 3) any U.S. application-as-filed from which benefit is sought in the instant patent application.

In accordance with 37 CFR 1.14(c), access may be provided to information concerning the date of filing this Authorization.

Applicant Information:

Providing assignment information in this section does not substitute for compliance with any requirement of part 3 of Title 37 of CFR to have an assignment recorded by the Office.			
Applicant 1			
If the applicant is the inventor (or the remaining joint inventor or inventors under 37 CFR 1.45), this section should not be completed. The information to be provided in this section is the name and address of the legal representative who is the applicant under 37 CFR 1.43; or the name and address of the assignee, person to whom the inventor is under an obligation to assign the invention, or person who otherwise shows sufficient proprietary interest in the matter who is the applicant under 37 CFR 1.46. If the applicant is an applicant under 37 CFR 1.46 (assignee, person to whom the inventor is obligated to assign, or person who otherwise shows sufficient proprietary interest) together with one or more joint inventors, then the joint inventor or inventors who are also the applicant should be identified in this section.			
<input type="button" value="Clear"/>			
<input checked="" type="radio"/> Assignee	<input type="radio"/> Legal Representative under 35 U.S.C. 117	<input type="radio"/> Joint Inventor	
<input type="radio"/> Person to whom the inventor is obligated to assign.		<input type="radio"/> Person who shows sufficient proprietary interest	
If applicant is the legal representative, indicate the authority to file the patent application, the inventor is:			
Name of the Deceased or Legally Incapacitated Inventor : <input type="text"/>			
If the Applicant is an Organization check here. <input checked="" type="checkbox"/>			
Organization Name	3SHAPE A/S		
Mailing Address Information:			
Address 1	Holmens Kanal 7		
Address 2			
City	Copenhagen K	State/Province	OT
Country i	DK	Postal Code	DK-1060
Phone Number		Fax Number	

Application Data Sheet 37 CFR 1.76		Attorney Docket Number	0079124-000111
		Application Number	
Title of Invention	FOCUS SCANNING APPARATUS RECORDING COLOR		

Email Address	
---------------	--

Additional Applicant Data may be generated within this form by selecting the Add button.

Assignee Information including Non-Applicant Assignee Information:

Providing assignment information in this section does not substitute for compliance with any requirement of part 3 of Title 37 of CFR to have an assignment recorded by the Office.

Assignee 1			
Complete this section if assignee information, including non-applicant assignee information, is desired to be included on the patent application publication. An assignee-applicant identified in the "Applicant Information" section will appear on the patent application publication as an applicant. For an assignee-applicant, complete this section only if identification as an assignee is also desired on the patent application publication.			
If the Assignee or Non-Applicant Assignee is an Organization check here <input checked="" type="checkbox"/>			
Organization Name	3SHAPE A/S		
Mailing Address Information For Assignee including Non-Applicant Assignee:			
Address 1	Holmens Kanal 7		
Address 2			
City	Copenhagen K	State/Province	OT
Country i	DK	Postal Code	DK-1060
Phone Number		Fax Number	
Email Address			
Additional Assignee or Non-Applicant Assignee Data may be generated within this form by selecting the Add button.			

Signature:

NOTE: This form must be signed in accordance with 37 CFR 1.33. See 37 CFR 1.4 for signature requirements and certifications					
Signature	/Travis D. Boone/				
First Name	Travis	Last Name	Boone	Registration Number	52635
Additional Signature may be generated within this form by selecting the Add button.					

EPI4 / S2842



Kongeriget Danmark

Patent application No.: PA 2013 70077
Date of filing: 13 February 2013
Applicant: 3Shape A/S
(Name and address) Holmens Kanal 7
DK-1060 Copenhagen K
Denmark

Title: Focus scanning apparatus recording color

IPC: G 01 B 11/24; A 61 C 9/00; G 01 J 3/46; G 06 T 7/40

This is to certify that the attached documents are exact copies of the above mentioned patent application as originally filed.



Patent- og Varemærkestyrelsen
Erhvervs- og Vækstministeriet

20 February 2014

A handwritten signature in black ink, appearing to read 'M. / S'.

Maria Limneos

Focus scanning apparatus recording color**Field of the invention**

- 5 The invention relates to three dimensional (3D) scanning of the surface geometry and surface color of objects. A particular application is within dentistry, particularly for intraoral scanning.

Background of the invention

10

3D scanners are widely known from the art, and so are intraoral dental 3D scanners (e.g., Sirona Cerec, Cadent Itero, 3Shape TRIOS).

15 The ability to record surface color is useful in many applications. For example in dentistry, the user can differentiate types of tissue or detect existing restorations. For example in materials inspection, the user can detect surface abnormalities such as crystallization defects or discoloring. None of the above is generally possible from 3D surface information alone.

20 WO2010145669 mentions the possibility of recording color. In particular, several sequential images, each taken for an illumination in a different color - typically blue, green, and red - are combined to form a synthetic color image. This approach hence requires means to change light source color, such as color filters. Furthermore, in handheld use, the scanner will move relative to the scanned object
25 during the illumination sequence, reducing the quality of the synthetic color image.

Also US7698068 and US8102538 (Cadent Inc.) describe an intraoral scanner that records both 3D geometry data and 3D texture data with one or more image sensor(s). However, there is a slight delay between the color and the 3D geometry
30 recording, respectively. US7698068 requires sequential illumination in different colors to form a synthetic image, while US8102538 mentions white light as a possibility, however from a second illumination source or recorded by a second image sensor, the first set being used for recording the 3D geometry.

WO2012083967 discloses a scanner for recording 3D geometry data and 3D texture data with two separate cameras. While the first camera has a relatively shallow depth of field as to provide focus scanning based on multiple images, the second camera has a relatively large depth of field as to provide color texture information from a single image.

Color-recording scanning confocal microscopes are also known from the prior art (e.g., Keyence VK9700; see also JP2004029373). A white light illumination system along with a color image sensor is used for recording 2D texture, while a laser beam forms a dot that is scanned, i.e., moved over the surface and recorded by a photomultiplier, providing the 3D geometry data from many depth measurements, one for each position of the dot. The principle of a moving dot requires the measured object not to move relative to the microscope during measurement, and hence is not suitable for handheld use.

15

Summary of the invention

It is an object of the present invention to provide a scanner for obtaining the 3D surface geometry and surface color of the surface of an object, which does not require that some 2D images are recorded for determining the 3D surface geometry while other images are recorded for determining the surface color.

It is an object of the present invention to provide a scanner for obtaining the 3D surface geometry and surface color of the surface of an object, which obtains surface color and the 3D surface geometry simultaneously such that an alignment of data relating to 3D surface geometry and data relating to surface color is not required.

Disclosed is a scanner for obtaining 3D surface geometry and surface color of an object, the scanner comprising:

30

- a multichromatic light source configured for providing a probe light, and

- a color image sensor comprising an array of image sensor pixels for recording one or more 2D images of light received from said object,

where at least for a block of said image sensor pixels, both surface color and 3D surface geometry of a part of the object are derived at least partly from one 2D
5 image recorded by said color image sensor

Disclosed is a scanner for obtaining 3D surface geometry and surface color of an object, the scanner comprising:

- a multichromatic light source configured for providing a probe light,
- 10 - a color image sensor comprising an array of image sensor pixels, and
- an optical system configured for guiding light received from the object to the color image sensor such that 2D images of said object can be recorded by said color image sensor;

wherein the scanner is configured for acquiring a number of said 2D images of a
15 part of the object and for deriving both surface color and 3D surface geometry of the part of the object from at least one of said recorded 2D images at least for a block of said image sensor pixels, such that the surface color and 3D surface geometry are obtained concurrently by the scanner.

20 Disclosed is a scanner for obtaining 3D surface geometry and surface color of an object, the scanner comprising:

- a multichromatic light source configured for providing a probe light;
- a color image sensor comprising an array of image sensor pixels, where the image sensor is arranged to record 2D images of light received from
25 the object; and

- an image processor configured for deriving both surface color and 3D surface geometry of at least a part of the object from at least one of said 2D images recorded by the color image sensor.

5 Disclosed is a scanner system for obtaining 3D surface geometry and surface color of an object, said scanner system comprising

- a scanner according to any of the embodiments, where the scanner is configured for deriving surface color and 3D surface geometry of the object, and optionally for obtaining a partial or full 3D surface geometry of the part of the object; and
- 10 - a data processing unit configured for post-processing 3D surface geometry and/or surface color readings from the color image sensor, or for post-processing the obtained partial or full 3D surface geometry.

15 In some embodiments, the data processing unit comprises a computer readable medium on which is stored computer implemented algorithms for performing said post-processing.

In some embodiments, the data processing unit is integrated in a cart or a personal computer.

20 Disclosed is a method of obtaining 3D surface geometry and surface color of an object, the method comprising:

- providing a scanner or scanner system according to any of the embodiments;
- illuminating the surface of said object with probe light from said
- 25 multichromatic light source;
- recording one or more 2D images of said object using said color image sensor; and

- deriving both surface color and 3D surface geometry of a part of the object from at least some of said recorded 2D images at least for a block of said image sensor pixels, such that the surface color and 3D surface geometry are obtained concurrently by the scanner.

5

The present invention is a significant improvement over the state of the art in that only a single image sensor and a single multichromatic light source is required, and that surface color and 3D surface geometry for at least a part of the object can be derived from the same image or images, which also means that alignment of color and 3D surface geometry is inherently perfect. In the scanner according to
10 the present invention, there is no need for taking into account or compensating for relative motion of the object and scanner between obtaining 3D surface geometry and surface color. Since the 3D surface geometry and the surface color are obtained at precisely the same time, the scanner automatically maintains its
15 spatial disposition with respect to the object surface while obtaining the 3D surface geometry and the surface color. This makes the scanner of the present invention suitable for handheld use, for example as an intraoral scanner, or for scanning moving objects.

In the context of the present invention, the phrase "surface color" may refer to the
20 apparent color of an object surface and thus in some cases, such as for semi-transparent or semi-translucent objects such as teeth, be caused by light from the object surface and/or the material below the object surface, such as material immediately below the object surface.

In some embodiments, the 3D surface geometry and the surface color are both
25 determined from light recorded by the color image sensor.

In some embodiments, the light received from the object originates from the multichromatic light source, i.e. it is probe light reflected or scattered from the surface of the object.

In some embodiments, the light received from the object is fluorescence excited by the probe light from the multichromatic light source, i.e. fluorescence emitted by fluorescent materials in the object surface.

5 In some embodiments, a second light source is used for the excitation of fluorescence while the multichromatic light source provides the light for obtaining the geometry and color of the object.

10 In some embodiments, the scanner comprises a first optical system, such as an arrangement of lenses, for transmitting the probe light from the multichromatic light source towards an object and a second optical system for imaging light received from the object at the color image sensor.

15 In some embodiments, only one optical system images the probe light onto the object and images the object, or at least a part of the object, onto the color image sensor, preferably along the same optical axis, however along opposite optical paths. The scanner may comprise at least one beam splitter located in the optical path, where the beam splitter is arranged such that it directs the probe light from the multichromatic light source towards the object while it directs light received from the object towards the color image sensor.

20 In some embodiments, the surface color and 3D surface geometry of the part of the object are derived from a plurality of recorded 2D images. In that case, both surface color and 3D surface geometry of the part of the object can be derived from a number of the plurality of recorded 2D images.

Several scanning principles are suitable for this invention, such as triangulation and focus scanning.

25 In some embodiments, the scanner is a focus scanner configured for obtaining a stack of 2D images of the object from a number of different focus plane positions. In some focus scanning embodiments, the focus plane is adjusted in such a way that the image of e.g. a spatial pattern projected by the light source on the probed object is shifted along the optical axis while recording 2D images at a number of focus plane positions such that said stack of recorded 2D images can be obtained

for a given position of the scanner relative to the object. The focus plane position may be varied by means of at least one focus element, e.g., a moving focus lens.

In some focus scanner embodiments, the scanner comprises means for incorporating a spatial pattern in said probe light and means for evaluating a correlation measure at each focus plane position between at least one image pixel and a weight function, where the weight function is determined based on information of the configuration of the spatial pattern. Determining in-focus information may then relate to calculating a correlation measure of the spatially structured light signal provided by the pattern with the variation of the pattern itself (which we term reference) for every location of the focus plane and finding the location of an extremum of this series. In some embodiments, the pattern is static. Such a static pattern can for example be realized as a chrome-on-glass pattern.

One way to define the correlation measure mathematically with a discrete set of measurements is as a dot product computed from a signal vector, $I = (I_1, \dots, I_n)$, with $n > 1$ elements representing sensor signals and a reference vector, $f = (f_1, \dots, f_n)$, of reference weights. The correlation measure A is then given by

$$A = f \cdot I = \sum_{i=1}^n f_i I_i$$

The indices on the elements in the signal vector represent sensor signals that are recorded at different pixels, typically in a block of pixels. The reference vector f can be obtained in a calibration step.

By using knowledge of the optical system used in the scanner, it is possible to transform the location of an extremum of the correlation measure, i.e., the focus plane into depth data information, on a pixel block basis. All pixel blocks combined thus provide an array of depth data. In other words, depth is along an optical path that is known from the optical design and/or found from calibration, and each block of pixels on the image sensor represents the end point of an optical path. Therefore, depth along an optical path, for a bundle of paths, yields a 3D surface geometry within the field of view of the scanner.

It can be advantageous to smooth and interpolate the series of correlation measure values, such as to obtain a more robust and accurate determination of the location of the maximum. For example, a polynomial can be fitted to the values of A for a pixel block over several images on both sides of the recorded maximum, and a location of a deducted maximum can be found from the maximum of the fitted polynomial, which can be in between two images.

Color for a block of pixels is at least partially derived from the same image from which 3D geometry is derived. In case the location of the maximum of A is represented by an image, then also color is derived from that same image. In case the location of the maximum of A is found by interpolation to be between two images, then at least one of those two images should be used to derive color, or both images using interpolation for color also. It is also possible to average color data from more than two images used in the determination of the location of the maximum of the correlation measure, or to average color from a subset or superset of multiple images used to derive 3D surface geometry. In any case, some image sensor pixels readings are used to derive both surface color and 3D surface geometry for at least a part of the scanned object.

Typically, there are three color filters, so the overall color is composed of three contributions, such as red, green, and blue, or cyan, magenta, and yellow. Note that color filters typically allow a range of wavelengths to pass, and there is typically cross-talk between filters, such that, for example, some green light will contribute to the intensity measured in pixels with red filters.

For an image sensor with a color filter array, a color component c_j within a pixel block can be obtained as

$$c_j = \sum_{i=1}^n g_{j,i} I_i$$

where $g_{j,i} = 1$ if pixel i has a filter for color c_j , 0 otherwise. For an RGB filter array like in a Bayer pattern, j is one of red, green, or blue. Further weighting of the individual color components, i.e., color calibration, may be required to obtain natural color data, typically as compensation for varying filter efficiency,

illumination source efficiency, and different fraction of color components in the filter pattern. The calibration may also depend on focus plane location and/or position within the field of view, as the mixing of the light source component colors may vary with those factors.

5 In some embodiments, color is obtained for every pixel in a pixel block. In sensors with a color filter array or with other means to separate colors such as diffractive means, depending on the color measured with a particular pixel, an intensity value for that color is obtained. In other words, in this case a particular pixel has a color value only for one color. Recently developed color image sensors allow
10 measurement of several colors in the same pixel, at different depths in the substrate, so in that case, a particular pixel can yield intensity values for several colors. In summary, it is possible to obtain a resolution of the surface color data that is inherently higher than that of the 3D geometry data.

In the embodiments where color resolution is higher than 3D geometry resolution,
15 a pattern will be visible when at least approximately in focus, which preferably is the case when color is derived. The image can be filtered such as to visually remove the pattern, however at a loss of resolution. In fact, it can be advantageous to be able to see the pattern for the user. For example in intraoral scanning, it may be important to detect the position of a margin line, the rim or
20 edge of a preparation. The image of the pattern overlaid on the 3D geometry of this edge is sharper on a side that is seen approximately perpendicular, and more blurred on the side that is seen at an acute angle. Thus, a user, who in this example typically is a dentist or dental technician, can use the difference in sharpness to more precisely locate the position of the margin line than may be
25 possible from examining the 3D surface geometry alone.

High spatial contrast of the in-focus pattern image on the object is desirable to obtain a good signal to noise ratio of the correlation measure on the color image sensor. Improved spatial contrast can be achieved by preferential imaging of the specular surface reflection from the object on the color image sensor. Thus, some
30 embodiments of the invention comprise means for preferential/selective imaging of specularly reflected light. This may be provided if the scanner further comprises

means for polarizing the probe light, for example by means of at least one polarizing beam splitter.

In some embodiments, the polarizing optics is coated such as to optimize preservation of the circular polarization of a part of the spectrum of the
5 multichromatic light source that is used for obtaining the 3D surface geometry.

The scanner according to the invention may further comprise means for changing the polarization state of the probe light and/or the light received from the object. This can be provided by means of a retardation plate, preferably located in the optical path. In some embodiments of the invention the retardation plate is a
10 quarter wave retardation plate.

Especially for intraoral applications, the scanner can have an elongated tip, with means for directing the probe light and/or imaging an object. This may be provided by means of at least one folding element. The folding element could be a light reflecting element such as a mirror or a prism.

15 For a more in-depth description of the above aspects of this invention, see WO2010145669.

The invention disclosed here comprises a multichromatic light source, for example a white light source, for example a multi-die LED.

Light received from the scanned object, such as probe light returned from the
20 object surface or fluorescence generated by the probe light by exciting fluorescent parts of the object, is recorded by a color image sensor. In some embodiments, the color image sensor comprises a color filter array such that every pixel in the color image sensor is a color-specific filter. The color filters are preferably arranged in a regular pattern, for example where the color filters are arranged
25 according to a Bayer color filter pattern. The image data thus obtained are used to derive both 3D surface geometry and surface color for each block of pixels. For a focus scanner utilizing a correlation measure, the 3D surface geometry may be found from an extremum of the correlation measure as described above.

In some embodiments, the 3D surface geometry is derived from light in a first part
30 of the spectrum of the probe light provided by the multichromatic light source.

Preferably, the color filters are aligned with the image pixels, preferably such that each pixel has a color filter for a particular color only.

In some embodiments, the color filter array is such that its proportion of pixels with color filters that match the first part of the spectrum is larger than 50%.

- 5 In some embodiments, the scanner is configured to derive the surface color with a higher resolution than the 3D surface geometry.

In some embodiments, the higher surface color resolution is achieved by demosaicing, where color values for pixel blocks may be demosaiced to achieve an apparently higher resolution of the color image than is present in the 3D
10 surface geometry. The demosaicing may operate on pixel blocks or individual pixels.

In case a multi-die LED or another illumination source comprising physically or optically separated light emitters is used, it is preferable to aim at a Köhler type illumination in the scanner, i.e. the illumination source is defocused at the object
15 plane in order to achieve uniform illumination and good color mixing for the entire field of view. In case color mixing is not perfect and varies with focal plane location, color calibration of the scanner will be advantageous.

It can be preferable to compute the 3D surface geometry only from pixels with one or two kinds of color filters. A single color requires no achromatic optics and is thus
20 provides for a scanner that is easier and cheaper to build. Furthermore, folding elements can generally not preserve the polarization state for all colors equally well. When only some color(s) is/are used to compute 3D surface geometry, the reference vector f will contain zeros for the pixels with filters for the other color(s). Accordingly, the total signal strength is generally reduced, but for large enough
25 blocks of pixels, it is generally still sufficient. Preferentially, the pixel color filters are adapted for little cross-talk from one color to the other(s). Note that even in the embodiments computing geometry from only a subset of pixels, color is preferably still computed from all pixels.

To obtain a full 3D surface geometry and color representation of an object, i.e. a
30 colored full 3D surface geometry of said part of the object surface, typically several

partial representations of the object have to be combined, where each partial representation is a view from substantially the same relative position of scanner and object. In the present invention, a view from a given relative position preferably obtains the 3D geometry and color of the object surface as seen from
5 that relative position.

For a focus scanner, a view corresponds to one pass of the focusing element(s), i.e. for a focus scanner each partial representation is the 3D surface geometry and color derived from the stack of 2D images recorded during the pass of the focus plane position between its extremum positions.

10 The 3D surface geometry found for various views can be combined by algorithms for stitching and registration as widely known in the literature, or from known view positions and orientations, for example when the scanner is mounted on axes with encoders. Color can be interpolated and averaged by methods such as texture weaving, or by simply averaging corresponding color components in multiple views
15 of the same location on the 3D surface. Here, it can be advantageous to account for differences in apparent color due to different angles of incidence and reflection, which is possible because the 3D surface geometry is also known. Texture weaving is described by e.g. Callieri M, Cignoni P, Scopigno R. "Reconstructing textured meshes from multiple range rgb maps". VMV 2002, Erlangen, Nov 20-22,
20 2002.

In some embodiments, the scanner and/or the scanner system is configured for generating a partial representation of the object surface based on the obtained surface color and 3D surface geometry.

In some embodiments, the scanner and/or the scanner system is configured for
25 combining partial representations of the object surface obtained from different relative positions to obtain a full 3D surface geometry and color representation of the part of the object.

In some embodiments, the combination of partial representations of the object to obtain the full 3D surface geometry and color representation comprises computing
30 the color in each surface point as a weighted average of corresponding points in all overlapping partial 3D surface geometries at that surface point. The weight of

each partial presentation in the sum may be determined by several factors, such as the presence of saturated pixel values or the orientation of the object surface with respect to the scanner.

5 Such a weighted average is advantageous in cases where some scanner positions and orientations relative to the object will give a better estimate of the actual color than other positions and orientations. If the illumination of the object surface is uneven this can to some degree also be compensated for by weighting the best illuminated parts higher.

10 In some embodiments, the scanner comprises an image processor configured for performing a post-processing of the 3D surface geometry, the surface color readings, or the derived partial or full 3D surface geometries of the object. The scanner may be configured for performing the combination of the partial representations using e.g. computer implemented algorithms executed by an image processor of the scanner.

15 The scanner system may be configured for performing the combination of the partial representations using e.g. computer implemented algorithms executed by the data processing unit as part of the post-processing of the 3D surface geometry, surface color, partial 3D geometry and/or full 3D geometry, i.e. the post-processing comprises computing the color in each surface point as a weighted
20 average of corresponding points in all overlapping partial 3D surface geometries at that surface point.

25 Saturated pixel values should preferably have a low weight to reduce the effect of highlights on the recording of the surface color. The color for a given part of the surface should preferably be determined primarily from 2D images where the color can be determined precisely which is not the case when the pixel values are saturated.

30 In some embodiments, the scanner and/or scanner system is configured for detecting saturated pixels in the recorded 2D images and for mitigating or removing the error in the obtained color caused by the pixel saturation. The error caused by the saturated pixel may be mitigated or removed by assigning a low weight to the saturated pixel in the weighted average.

Specularly reflected light has the color of the light source rather than the color of the object surface. If the object surface is not a pure white reflector then specular reflections can hence be identified as the areas where the pixel color closely matches the light source color. When obtaining the surface color it is therefore
5 advantageous to assign a low weight to pixels or pixel groups whose color values closely match the color of the multichromatic light source in order to compensate for such specular reflections.

Specular reflections may also be a problem when intra orally scanning a patient's set of teeth since teeth rarely are completely white. It may hence be advantageous
10 to assume that for pixels where the readings from the color images sensor indicate that the surface of the object is a pure white reflector, the light recorded by this pixel group is caused by a specular reflection from the teeth or the soft tissue in the oral cavity and accordingly assign a low weight to these pixels to compensate for the specular reflections.

15 In some embodiments, the compensation for specular reflections from the object surface is based on information derived from a calibration of the scanner in which a calibration object e.g. in the form of a pure white reflector is scanned. The color image sensor readings then depend on the spectrum of the multichromatic light source and on the wavelength dependence of the scanner's optical system caused
20 by e.g. a wavelength dependent reflectance of mirrors in the optical system. If the optical system guides light equally well for all wavelengths of the multichromatic light source, the color image sensor will record the color (also referred to as the spectrum) of the multichromatic light source when the pure white reflector is scanned.

25 In some embodiments, compensating for the specular reflections from the surface is based on information derived from a calculation based on the wavelength dependence of the scanner's optical system, the spectrum of the multichromatic light source and a wavelength dependent sensitivity of the color image sensor. In
30 some embodiments, the scanner comprises means for optically suppressing specularly reflected light to achieve better color measurement. This may be provided if the scanner further comprises means for polarizing the probe light, for example by means of at least one polarizing beam splitter.

When scanning inside an oral cavity there may be red ambient light caused by probe light illumination of surrounding tissue, such as the gingiva, palette, tongue or buccal tissue. In some embodiments, the scanner and/or scanner system is hence configured for suppressing the red component in the recorded 2D images.

- 5 In some embodiments, the scanner and/or scanner system is configured for comparing the color of sections of the recorded 2D images and/or of the partial presentations of the object with predetermined color ranges for teeth and for oral tissue, respectively, and for suppressing the red component of the recorded color for sections where the color is not in either one of the two predetermined color
- 10 ranges. The teeth may e.g. be assumed to be primarily white with one ratio between the intensity of the different components of the recorded image, e.g. with one ratio between the intensity of the red component and the intensity of the blue and/or green components in a RGB configuration, while oral tissue is primarily reddish with another ratio between the intensity of the components. When a color
- 15 recorded for a region of the oral cavity shows a ratio which differs from both the predetermined ratio for teeth and the predetermined ratio for tissue, this region is identified as a tooth region illuminated by red ambient light and the red component of the recorded image is suppressed relative to the other components, either by reducing the recorded intensity of the red signal or by increasing the recorded
- 20 intensities of the other components in the image.

In some embodiments, the color of points with a surface normal directly towards the scanner are weighted higher than the color of points where the surface normal is not directed towards the scanner. This has the advantage that points with a surface normal directly towards the scanner will to a higher degree be illuminated

25 by the white light from the scanner and not by the ambient light.

In some embodiments, the color of points with a surface normal directly towards the scanner are weighted lower if associated with specular reflections.

In some embodiments the scanner is configured for simultaneously compensating for different effects, such as compensating for saturated pixels and/or for specular

30 reflections and/or for orientation of the surface normal. This may be done by generally raising the weight for a selection of pixels or pixel groups of a 2D image

and by reducing the weight for a fraction of the pixels or pixel groups of said selection.

In some embodiments, the method comprises a processing of recorded 2D images, partial or full 3D representations of the part of the object, where said

5 processing comprises

- compensating for pixel saturation by omitting or reducing the weight of saturated pixels when deriving the surface color, and/or
- compensating for specular reflections when deriving the surface color by omitting or reducing the weight of pixels whose color values closely
- 10 matches the light source color, and/or
- compensating for red ambient light by comparing color of the 2D images with predetermined color ranges, and suppressing the red component of the recorded color if this is not within a predetermined color range.

15 Disclosed is a method of using a scanner of this invention to display color texture on 3D surface geometry. It is advantageous to display the 2D color data as a texture on the 3D surface geometry, for example on a computer screen. The combination of color and geometry is a more powerful conveyor of information than either type of data alone. For example, dentists can more easily differentiate

20 between different types of tissue. In the rendering of the 3D surface geometry, appropriate shading can help convey the 3D surface geometry on the texture, for example with artificial shadows revealing sharp edges better than texture alone could do.

When the multichromatic light source is a multi-die LED or similar, the scanner of

25 this invention can also be used to detect fluorescence. Disclosed is a method of using the scanner of the invention to display fluorescence on 3D surface geometry.

In some embodiments, the scanner is configured for exciting fluorescence on said object by illuminating it with only a subset of the LED dies in the multi-die LED,

and where said fluorescence is recorded by only or preferentially reading out only those pixels in the color image sensor that have color filters at least approximately matching the color of the fluoresced light, i.e. measuring intensity only in pixels of the image sensors that have filters for longer-wavelength light. In other words, the scanner is capable of selectively activating only a subset of the LED dies in the multi-die LED and of only recording or preferentially reading out only those pixels in the color image sensor that have color filters at a higher wavelength than that of the subset of the LED dies, such that light emitted from the subset of LED dies can excite fluorescent materials in the object and the scanner can record the fluorescence emitted from these fluorescent materials. The subset of the dies preferably comprises one or more LED dies which emits light within the excitation spectrum of the fluorescent materials in the object, such as an ultraviolet, a blue, a green, a yellow or a red LED die. Such fluorescence measurement yields a 2D data array much like the 2D color image, however unlike the 2D image it cannot be taken concurrently with the 3D surface geometry. For a slow-moving scanner, and/or with appropriate interpolation, the fluorescence image can still be overlaid the 3D surface geometry. It is advantageous to display fluorescence on teeth because it can help detect caries and plaque.

In some embodiments, the processing means comprises a microprocessor unit configured for extracting the 3D surface geometry from 2D images obtained by the color image sensor and for determining the surface color from the same images.

Disclosed is a method of using a scanner of this invention to average color and/or 3D surface geometry from several views, where each view represents a substantially fixed relative orientation of scanner and object.

Disclosed is a method using a scanner of this invention to combine color and/or 3D surface geometry from several views, where each view represents a substantially fixed relative orientation of scanner and object, such as to achieve a more complete coverage of the object than would be possible in a single view.

Brief description of drawings

Fig. 1 shows a handheld embodiment of the scanner according to the invention.

Fig. 2 shows prior art pattern generating means and associated reference weights.

Fig. 3 shows a pattern generating means and associated reference weights according to the present invention.

5 Fig. 4 shows a color filter array according to the present invention

The scanner embodiment illustrated in fig. 1 is a hand-held scanner with components inside the housing 100. The scanner comprises a tip which can be entered into a cavity, a multichromatic light source in the form of a multi-die LED
10 101, pattern generation means 130 for incorporating a spatial pattern in the probe light, a beam splitter 140, an image acquisition means 180 including an image sensor 181, electronics and potentially other elements, an optical system typically comprising at least one lens, the object being scanned 200, and the image sensor. The light from the light source 101 travels back and forth through the optical
15 system 150. During this passage the optical system images the pattern 130 onto the object being scanned 200 and further images the object being scanned onto the image sensor 181.

The image sensor 181 has a color filter array 1000. Although drawn as a separate entity because of its importance in the invention, the color filter array is typically
20 integrated with the image sensor, with a single-color filter for every pixel.

The lens system includes a focusing element 151 which can be adjusted to shift the focal imaging plane of the pattern on the probed object 200. In the example embodiment, a single lens element is shifted physically back and forth along the optical axis.

25 As a whole, the optical system provides an imaging of the pattern onto the object being probed and from the object being probed to the camera.

The device may include polarization optics 160. Polarization optics can be used to selectively image specular reflections and block out undesired diffuse signal from sub-surface scattering inside the scanned object. The beam splitter 140 may also

have polarization filtering properties. It can be advantageous for optical elements to be anti-reflection coated.

The device may include folding optics, a mirror 170, which directs the light out of the device in a direction different to the optical axis of the lens system, e.g. in a direction perpendicular to the optical axis of the lens system.

There may be additional optical elements in the scanner, for example one or more condenser lens in front of the light source 101.

In the example embodiment, the LED 101 is a multi-die LED with two green, one red, and one blue die. Only the green portion of the light is used for obtaining the 3D surface geometry. Accordingly, the mirror 170 is coated such as to optimize preservation of the circular polarization of the green light, and not that of the other colors. Note that during scanning all dies within the LED are active, i.e., emitting light, so the scanner emits apparently white light onto the scanned object 200. The LED may emit light at the different colors with different intensities such that e.g. one color is more intense than the other colors. This may be desired in order to reduce cross-talk between the readings of the different color signals in the color image sensor. In case that the intensity of e.g. the red and blue diodes in a RGB system is reduced, the apparently white light emitted by the light source will appear greenish-white.

Figure 2 shows an example of prior art pattern generation means 130 that is applied as a static pattern in a spatial correlation embodiment of WO20101455669, as imaged on a monochromatic image sensor 180. The pattern can be a chrome-on-glass pattern. Only a portion of the pattern is shown, namely one period. This period is represented by a pixel block of 6 by 6 image pixels, and 2 by 2 pattern fields. The fields drawn in gray in Fig. 2 (a) are in actuality black because the pattern mask is opaque for these fields; gray was only chosen for visibility and thus clarity of the Figure. Figure 2(b) illustrates the reference weights f for computing the spatial correlation measure A for the pixel block, where $n = 6 \times 6 = 36$, such that

$$A = \sum_{i=1}^n f_i I_i$$

where I are the intensity values measured in the 36 pixels in the pixel block for a given image. Note that perfect alignment between image sensor pixels and pattern fields is not required, but gives the best signal for the 3D surface geometry measurement.

- 5 Figure 3 shows the extension of the principle in Figure 2 for the present invention. The pattern is the same as in Figure 2 and so is the image sensor geometry. However, the image sensor is a color image sensor with a Bayer color filter array. In Figure 2 (a), pixels marked “B” have a blue color filter, while “G” indicates green and “R” red pixel filters, respectively. Figure 2 (b) shows the corresponding
 10 reference weights f . Note that only green pixels have a non-zero value. This is so because only the green fraction of the spectrum is used for obtaining the 3D surface geometry.

For the pattern / color filter combination of Figure 3, a color component c_j within a pixel block can be obtained as

$$c_j = \sum_{i=1}^n g_{j,i} I_i$$

- 15 where $g_{j,i} = 1$ if pixel i has a filter for color c_j , 0 otherwise. For an RGB color filter array like in the Bayer pattern, j is one of red, green, or blue. Further weighting of the individual color components, i.e., color calibration, may be required to obtain natural color data, typically as compensation for varying filter efficiency, illumination source efficiency, and different fraction of color components in the filter
 20 pattern. The calibration may also depend on focus plane location and/or position within the field of view, as the mixing of the LED's component colors may vary with those factors.

- Figure 4 shows an alternative color filter array with a higher fraction of green pixels than in the Bayer pattern. Assuming that only the green portion of the illumination
 25 is used to obtain the 3D surface geometry, the filter of Figure 4 will potentially provide a better quality of the obtained 3D surface geometry than a Bayer pattern

filter, at the expense of poorer color representation. The poorer color representation will however in many cases still be sufficient while the improved quality of the obtained 3D surface geometry often is very advantageous.

Claims

1. A scanner for obtaining 3D surface geometry and surface color of an object, the scanner comprising:
 - 5 - a multichromatic light source configured for providing a probe light, and
 - a color image sensor comprising an array of image sensor pixels for recording one or more 2D images of light received from said object, where at least for a block of said image sensor pixels, both surface color and 3D surface geometry of a part of the object are derived at least
10 partly from one 2D image recorded by said color image sensor.
2. A scanner according to claim 1, wherein the surface color and 3D surface geometry of the part of the object are derived from a plurality of recorded 2D images, and where for a number of the plurality of recorded 2D images
15 both surface color and 3D surface geometry of the part of the object are derived.
3. A scanner according to any of the preceding claims where the scanner is a focus scanner configured for obtaining a stack of 2D images of the object
20 from a number of different focus plane positions.
4. A scanner according to the preceding claim where the scanner comprises means for incorporating a spatial pattern in said probe light and means for evaluating a correlation measure at each focus plane position between at
25 least one image pixel and a weight function, where the weight function is determined based on information of the configuration of the spatial pattern.
5. A scanner according to any of the preceding claims where the 3D surface geometry is derived from light in a first part of the spectrum provided by the
30 multichromatic light source, and where the color image sensor comprises a color filter array which is such that its proportion of pixels with color filters that match the first part of the spectrum is larger than 50%.

6. A scanner according to any of the preceding claims where the scanner is configured to derive the surface color with a higher resolution than the 3D surface geometry
- 5 7. A scanner according to any of the preceding claims where the scanner is configured for exciting fluorescence on said object by illuminating it with only a subset of the LED dies in the multi-die LED, and where said fluorescence is recorded by only or preferentially reading out only those pixels in the color image sensor that have color filters at least approximately
- 10 matching the color of the fluoresced light.
8. A scanner system for obtaining 3D surface geometry and surface color of an object, said scanner system comprising
- a scanner according to any of the preceding claims, where the scanner

15 is configured for deriving surface color and 3D surface geometry of the object, and optionally for obtaining a partial or full 3D surface geometry of the part of the object; and

 - a data processing unit configured for post-processing 3D surface geometry and/or surface color readings from the color image sensor, or

20 for post-processing the obtained partial or full 3D surface geometry.
- wherein the post-processing comprises computing the color in each surface point as a weighted average of corresponding points in all overlapping partial 3D surface geometries at that surface point.
9. The scanner system according to claim 8, wherein the scanner system is
- 25 configured for detecting saturated pixels in the recorded 2D images and for mitigating or removing the error in the obtained color caused by the pixel saturation, and wherein the error caused by the saturated pixel is mitigated or removed by assigning a low weight to the saturated pixel in the weighted average
- 30 10. The scanner system according to claim 8 or 9, wherein the scanner system is configured for comparing the color of sections of the recorded 2D images

and/or of the partial presentations of the object with predetermined color ranges for teeth and for oral tissue, and for suppressing the red component of the recorded color for sections where the color is not in one of the two predetermined color ranges.

Abstract

Disclosed is a scanner, a scanner system, a user interface and a method for obtaining 3D surface geometry and surface color of an object, the scanner comprising:

- 5 - a multichromatic light source configured for providing a probe light, and
- a color image sensor comprising an array of image sensor pixels for recording one or more 2D images of light received from said object, where at least for a block of said image sensor pixels, both surface color and 3D surface geometry of a part of the object are derived at least
- 10 partly from one 2D image recorded by said color image sensor.

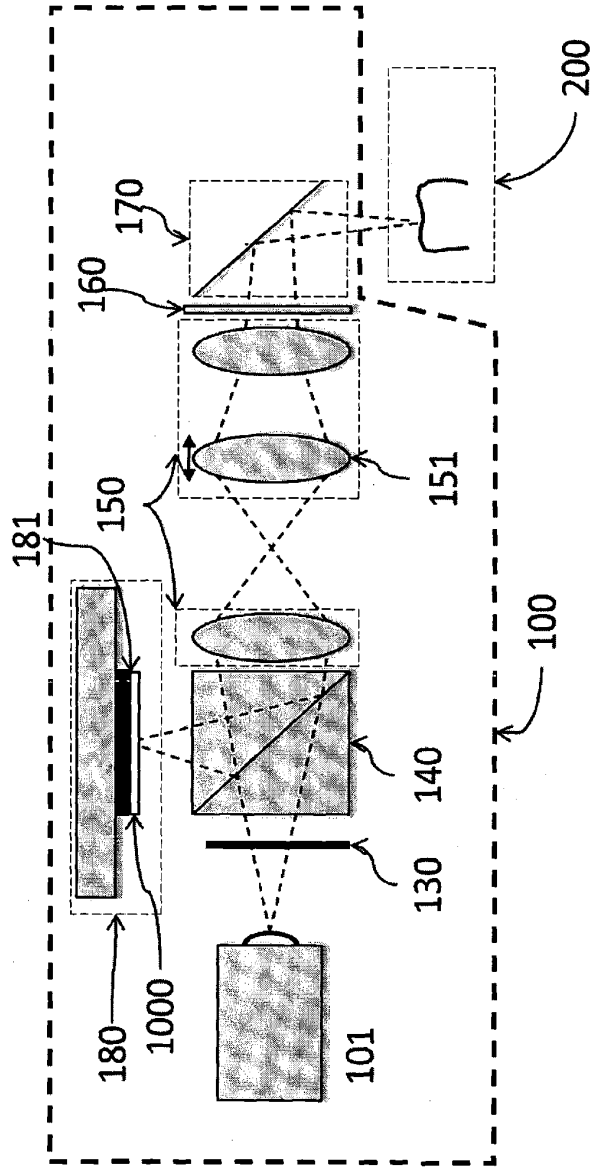
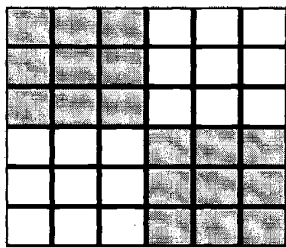

Fig. 1

2/3



(a)

-1	-1	-1	1	1	1
-1	-1	-1	1	1	1
-1	-1	-1	1	1	1
1	1	1	-1	-1	-1
1	1	1	-1	-1	-1
1	1	1	-1	-1	-1

(b)

Fig. 2

R	G	R	G	R	G
G	B	G	B	G	B
R	G	R	G	R	G
G	B	G	B	G	B
R	G	R	G	R	G
G	B	G	B	G	B

(a)

0	-1	0	1	0	1
-1	0	-1	0	1	0
0	-1	0	1	0	1
1	0	1	0	-1	0
0	1	0	-1	0	1
1	0	1	0	-1	0

(b)

Fig. 3

3/3

G	G	G	G	G	G
G	R	G	G	R	G
G	G	G	G	G	G
G	G	G	G	G	G
G	B	G	G	B	G
G	G	G	G	G	G

Fig. 4

**DOCUMENT MADE AVAILABLE UNDER THE
PATENT COOPERATION TREATY (PCT)**

International application number: **PCT/EP2014/052842**

International filing date: **13 February 2014 (13.02.2014)**

Document type: **Certified copy of priority document**

Document details: Country/Office: **DK**
 Number: **PA 2013 70077**
 Filing date: **13 February 2013 (13.02.2013)**

Date of receipt at the International Bureau: **11 April 2014 (11.04.2014)**

Remark: Priority document submitted or transmitted to the International Bureau in compliance with Rule 17.1(a),(b) or (b-bis)

PCT REQUEST

Print Out (Original in Electronic Form)

0	For receiving Office use only	
0-1	International Application No.	PCT/EP2014/052842
0-2	International Filing Date	13 FEB 2014 (13.02.2014)
0-3	Name of receiving Office and "PCT International Application"	RO/EP
0-4	Form PCT/RO/101 PCT Request	
0-4-1	Prepared Using	PCT Online Filing Version 3.5.000.235 MT/FOP 20020701/0.20.5.20
0-5	Petition The undersigned requests that the present international application be processed according to the Patent Cooperation Treaty	
0-6	Receiving Office (specified by the applicant)	European Patent Office (EPO) (RO/EP)
0-7	Applicant's or agent's file reference	P1439PC00
I	Title of Invention	FOCUS SCANNING APPARATUS RECORDING COLOR
II	Applicant	
II-1	This person is	Applicant only
II-2	Applicant for	All designated States
II-4	Name	3Shape A/S
II-5	Address	Holmens Kanal 7 1060 Copenhagen K Denmark
II-6	State of nationality	DK
II-7	State of residence	DK
III-1	Applicant and/or inventor	
III-1-1	This person is	Inventor only
III-1-3	Inventor for	
III-1-4	Name (LAST, First)	ESBECH, Bo
III-1-5	Address	Edvard Thomsens Vej 7A, 2.th 2100 Copenhagen Ø Denmark
III-2	Applicant and/or inventor	
III-2-1	This person is	Inventor only
III-2-3	Inventor for	
III-2-4	Name (LAST, First)	ROSBERG, Christian Romer
III-2-5	Address	Dybbølsgade 50, 3. 1721 Copenhagen V Denmark

PCT REQUEST

Print Out (Original in Electronic Form)

III-3	Applicant and/or inventor	
III-3-1	This person is	Inventor only
III-3-3	Inventor for	
III-3-4	Name (LAST, First)	VAN DER POEL, Mike
III-3-5	Address	Rævebakkevej 35B 2610 Rødovre Denmark
III-4	Applicant and/or inventor	
III-4-1	This person is	Inventor only
III-4-3	Inventor for	
III-4-4	Name (LAST, First)	KJÆR, Rasmus
III-4-5	Address	Nørre Søgade 21, 1. 1370 Copenhagen K Denmark
III-5	Applicant and/or inventor	
III-5-1	This person is	Inventor only
III-5-3	Inventor for	
III-5-4	Name (LAST, First)	VINTHER, Michael
III-5-5	Address	Tom Christens Vej 34, 4tv 2300 Copenhagen S Denmark
III-6	Applicant and/or inventor	
III-6-1	This person is	Inventor only
III-6-3	Inventor for	
III-6-4	Name (LAST, First)	HOLLENBECK, Karl-Josef
III-6-5	Address	Ribegade 12, 3th 2100 Copenhagen Ø Denmark

PCT REQUEST

Print Out (Original in Electronic Form)

IV-1	Agent or common representative; or address for correspondence The person identified below is hereby/ has been appointed to act on behalf of the applicant(s) before the competent International Authorities as:	Agent
IV-1-1	Name (LAST, First)	MÜNZER, Marc
IV-1-2	Address	Guardian IP Consulting I/S Diplomvej, Building 381 2800 Kgs. Lyngby Denmark
IV-1-3	Telephone No.	+45 70 27 53 63
IV-1-4	Facsimile No.	+45 70 27 53 62
IV-1-5	e-mail	mail@gipc.eu
IV-1-5(a))	E-mail authorization The receiving Office, the International Searching Authority, the International Bureau and the International Preliminary Examining Authority are authorized to use this e-mail address, if the Office or Authority so wishes, to send notifications issued in respect of this international application:	exclusively in electronic form (no paper notifications will be sent)
V	DESIGNATIONS	
V-1	The filing of this request constitutes under Rule 4.9(a), the designation of all Contracting States bound by the PCT on the international filing date, for the grant of every kind of protection available and, where applicable, for the grant of both regional and national patents.	
VI-1	Priority claim of earlier national application	
VI-1-1	Filing date	13 February 2013 (13.02.2013)
VI-1-2	Number	PA 2013 70077
VI-1-3	Country	DK
VI-2	Priority claim of earlier national application	
VI-2-1	Filing date	13 February 2013 (13.02.2013)
VI-2-2	Number	61/764,178
VI-2-3	Country	US

PCT REQUEST

Print Out (Original in Electronic Form)

VI-3	Incorporation by reference : where an element of the international application referred to in Article 11(1)(iii)(d) or (e) or a part of the description, claims or drawings referred to in Rule 20.5(a) is not otherwise contained in this international application but is completely contained in an earlier application whose priority is claimed on the date on which one or more elements referred to in Article 11(1)(iii) were first received by the receiving Office, that element or part is, subject to confirmation under Rule 20.6, incorporated by reference in this international application for the purposes of Rule 20.6.		
VII-1	International Searching Authority Chosen	European Patent Office (EPO) (ISA/EP)	
VII-2	Request to use results of earlier search; reference to that search		
VII-2-1	Filing date	13 February 2013 (13.02.2013)	
VII-2-2	Application Number	pa 2013 70077	
VII-2-3	Country (or regional Office)	DK	
VIII	Declarations	Number of declarations	
VIII-1	Declaration as to the identity of the inventor	—	
VIII-2	Declaration as to the applicant's entitlement, as at the international filing date, to apply for and be granted a patent	—	
VIII-3	Declaration as to the applicant's entitlement, as at the international filing date, to claim the priority of the earlier application	—	
VIII-4	Declaration of inventorship (only for the purposes of the designation of the United States of America)	—	
VIII-5	Declaration as to non-prejudicial disclosures or exceptions to lack of novelty	—	
IX	Check list	Number of sheets	Electronic file(s) attached
IX-1	Request (including declaration sheets)	5	✓
IX-2	Description	33	✓
IX-3	Claims	6	✓
IX-4	Abstract	1	✓
IX-5	Drawings	4	✓
IX-7	TOTAL	49	

PCT REQUEST

Print Out (Original in Electronic Form)

	Accompanying Items	Paper document(s) attached	Electronic file(s) attached
IX-8	Fee calculation sheet	-	✓
IX-17	Copy of the results of earlier search(es)	-	✓
IX-18	PCT-SAFE physical media	-	-
IX-20	Figure of the drawings which should accompany the abstract	1	
IX-21	Language of filing of the international application	English	
X-1	Signature of applicant, agent or common representative	(PKCS7 Digital Signature)	
X-1-1	Name	3Shape A/S	
X-1-2	Name of signatory	DK, 3Shape A/S, J. Jensen 31081	
X-1-3	Capacity (if such capacity is not obvious from reading the request)	(Applicant)	

FOR RECEIVING OFFICE USE ONLY

10-1	Date of actual receipt of the purported international application	13 FEB 2014 (13.02.2014)
10-2	Drawings:	✓
10-2-1	Received	
10-2-2	Not received	
10-3	Corrected date of actual receipt due to later but timely received papers or drawings completing the purported international application	
10-4	Date of timely receipt of the required corrections under PCT Article 11(2)	
10-5	International Searching Authority	ISA/EP
10-6	Transmittal of search copy delayed until search fee is paid	

FOR INTERNATIONAL BUREAU USE ONLY

11-1	Date of receipt of the record copy by the International Bureau	
------	---	--

EPK / 52842

PA 7461729

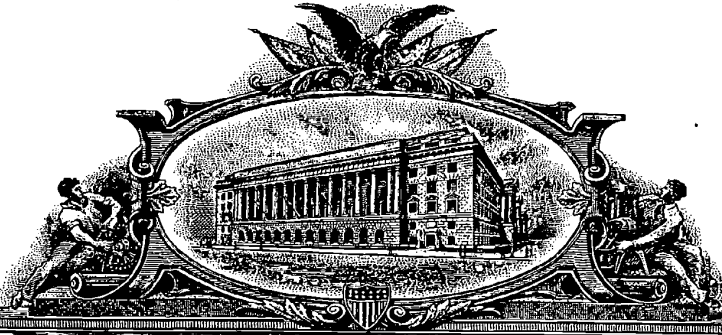

THE UNITED STATES OF AMERICA

TO ALL TO WHOM THESE PRESENTS SHALL COME:

UNITED STATES DEPARTMENT OF COMMERCE
United States Patent and Trademark Office

February 14, 2014

THIS IS TO CERTIFY THAT ANNEXED HERETO IS A TRUE COPY FROM THE RECORDS OF THE UNITED STATES PATENT AND TRADEMARK OFFICE OF THOSE PAPERS OF THE BELOW IDENTIFIED PATENT APPLICATION THAT MET THE REQUIREMENTS TO BE GRANTED A FILING DATE UNDER 35 USC 111.

APPLICATION NUMBER: 61/764,178

FILING DATE: February 13, 2013

THE COUNTRY CODE AND NUMBER OF YOUR PRIORITY APPLICATION, TO BE USED FOR FILING ABROAD UNDER THE PARIS CONVENTION, IS US61/764,178

By Authority of the
Under Secretary of Commerce for Intellectual Property
and Director of the United States Patent and Trademark Office



R. BLAKENEY
Certifying Officer

Electronic Acknowledgement Receipt

EFS ID:	14948175
Application Number:	61764178
International Application Number:	
Confirmation Number:	9122
Title of Invention:	FOCUS SCANNING APPARATUS RECORDING COLOR
First Named Inventor/Applicant Name:	Bo ESBECH
Customer Number:	21839
Filer:	William C. Rowland/Robin Copeland
Filer Authorized By:	William C. Rowland
Attorney Docket Number:	0079124-000065
Receipt Date:	13-FEB-2013
Filing Date:	
Time Stamp:	14:16:22
Application Type:	Provisional

Payment information:

Submitted with Payment	yes
Payment Type	Credit Card
Payment was successfully received in RAM	\$125
RAM confirmation Number	593
Deposit Account	
Authorized User	

File Listing:

Document Number	Document Description	File Name	File Size(Bytes)/ Message Digest	Multi Part /.zip	Pages (if appl.)
-----------------	----------------------	-----------	-------------------------------------	------------------	------------------

1	Drawings-only black and white line drawings	Drawings.pdf	165101 2f6877e2252484f96c4f611ea6ce1b8cb237de5	no	3
Warnings:					
Information:					
2	Specification	Provisional_Application.pdf	1331498 00f1b2c65d9ba43270c47a26de244a37aceb652	no	27
Warnings:					
Information:					
3	Transmittal of New Application	Provisional_Transmittal_Letter.pdf	74563 cfa4a57615d3c6a8dd45917633aa93f5c9e2968	no	1
Warnings:					
Information:					
4	Application Data Sheet	Application_Data_Sheet.pdf	281970 f4f6dd511d38382c782877db4933a842f942e280	no	10
Warnings:					
Information:					
This is not an USPTO supplied ADS fillable form					
5	Fee Worksheet (SB06)	fee-info.pdf	29793 a76437c1c2b068382886d52805cf45bd40a6b16f	no	2
Warnings:					
Information:					
Total Files Size (in bytes):				1882925	
<p>This Acknowledgement Receipt evidences receipt on the noted date by the USPTO of the indicated documents, characterized by the applicant, and including page counts, where applicable. It serves as evidence of receipt similar to a Post Card, as described in MPEP 503.</p> <p><u>New Applications Under 35 U.S.C. 111</u> If a new application is being filed and the application includes the necessary components for a filing date (see 37 CFR 1.53(b)-(d) and MPEP 506), a Filing Receipt (37 CFR 1.54) will be issued in due course and the date shown on this Acknowledgement Receipt will establish the filing date of the application.</p> <p><u>National Stage of an International Application under 35 U.S.C. 371</u> If a timely submission to enter the national stage of an international application is compliant with the conditions of 35 U.S.C. 371 and other applicable requirements a Form PCT/DO/EO/903 indicating acceptance of the application as a national stage submission under 35 U.S.C. 371 will be issued in addition to the Filing Receipt, in due course.</p> <p><u>New International Application Filed with the USPTO as a Receiving Office</u> If a new international application is being filed and the international application includes the necessary components for an international filing date (see PCT Article 11 and MPEP 1810), a Notification of the International Application Number and of the International Filing Date (Form PCT/RO/105) will be issued in due course, subject to prescriptions concerning national security, and the date shown on this Acknowledgement Receipt will establish the international filing date of the application.</p>					

PROVISIONAL APPLICATION FOR PATENT COVER SHEET

This is a request for filing a PROVISIONAL APPLICATION FOR PATENT under 37 C.F.R. § 1.53(c).

Attorney Docket Number **0079124-000065**

Inventor(s)						
Given Name	Middle Name	Family Name	CITY	STATE	COUNTRY	
Bo		ESBECH	Copenhagen S		Denmark	
Christian	Romer	ROSBERG	Copenhagen V		Denmark	
Mike		VAN DER POEL	Copenhagen V		Denmark	
Rasmus		KJÆR	Copenhagen K		Denmark	
Michael		VINTHER	Copenhagen S		Denmark	
Karl	Josef	HOLLENBECK	Copenhagen Ø		Denmark	
Title of Invention						
FOCUS SCANNING APPARATUS RECORDING COLOR						
Correspondence Address						
The address corresponding to Customer Number 2 1 8 3 9						
This invention was made by an agency of the United States Government or under a contract with an agency of the United States Government.						
<input checked="" type="checkbox"/> No. <input type="checkbox"/> Yes, the name of the U.S. Government agency and the Government contract number are:						
Enclosed Application Parts						
<input checked="" type="checkbox"/>	Specification/Claims/Abstract	# of Pages	27	<input type="checkbox"/>	CD(s) Number	
<input checked="" type="checkbox"/>	Drawings	# Sheets	3	<input type="checkbox"/>	Other (specify):	
Total Pages in Spec/Drawings			30			
<input checked="" type="checkbox"/> Application Data Sheet. See 37 CFR 1.76						
Method of Payment of Filing Fees				FILING FEE AMOUNT		
<input checked="" type="checkbox"/>	Applicant claims small entity status. See 37 CFR 1.27					
<input type="checkbox"/>	The undersigned hereby grants the USPTO authority to provide the European Patent Office (EPO), the Japan Patent Office (JPO), the Korean Intellectual Property Office (KIPO), the World Intellectual Property Office (WIPO), and any other intellectual property offices in which a foreign application claiming priority to the above-identified patent application is filed access to the above-identified patent application. See 37 CFR 1.14(c) and (h).				Filing Fee (2005)	\$ 125.00
<input type="checkbox"/>	The Director is hereby authorized to charge any deficiency in filing fees or credit any overpayment to Deposit Account 02-4800.				Total Page Fee (101+ pages) (2085) \$155	\$ 0.00
<input checked="" type="checkbox"/>	Payment by credit card. Payment will be made electronically at time of filing.				Total App. Filing Fee	\$ 125.00
<input type="checkbox"/>	Charge filing fee to Deposit Account 02-4800.					

SIGNATURE



DATE

February 13, 2013

TYPED or PRINTED NAME

William C. Rowland

Regis. No.

30888

703.836.6620

SEND TO: Commissioner for Patents, P.O. Box 1450, Alexandria, VA 22313-1450

Focus scanning apparatus recording color

Field of the invention

- 5 The invention relates to three dimensional (3D) scanning of the surface geometry and surface color of objects. A particular application is within dentistry, particularly for intraoral scanning.

Background of the invention

10

3D scanners are widely known from the art, and so are intraoral dental 3D scanners (e.g., Sirona Cerec, Cadent Itero, 3Shape TRIOS).

15

The ability to record surface color is useful in many applications. For example in dentistry, the user can differentiate types of tissue or detect existing restorations. For example in materials inspection, the user can detect surface abnormalities such as crystallization defects or discoloring. None of the above is generally possible from 3D surface information alone.

20

WO2010145669 mentions the possibility of recording color. In particular, several sequential images, each taken for an illumination in a different color - typically blue, green, and red - are combined to form a synthetic color image. This approach hence requires means to change light source color, such as color filters. Furthermore, in handheld use, the scanner will move relative to the scanned object

25 during the illumination sequence, reducing the quality of the synthetic color image.

30

Also US7698068 and US8102538 (Cadent Inc.) describe an intraoral scanner that records both 3D geometry data and 3D texture data with one or more image sensor(s). However, there is a slight delay between the color and the 3D geometry recording, respectively. US7698068 requires sequential illumination in different colors to form a synthetic image, while US8102538 mentions white light as a possibility, however from a second illumination source or recorded by a second image sensor, the first set being used for recording the 3D geometry.

WO2012083967 discloses a scanner for recording 3D geometry data and 3D texture data with two separate cameras. While the first camera has a relatively shallow depth of field as to provide focus scanning based on multiple images, the second camera has a relatively large depth of field as to provide color texture information from a single image.

Color-recording scanning confocal microscopes are also known from the prior art (e.g., Keyence VK9700; see also JP2004029373). A white light illumination system along with a color image sensor is used for recording 2D texture, while a laser beam forms a dot that is scanned, i.e., moved over the surface and recorded by a photomultiplier, providing the 3D geometry data from many depth measurements, one for each position of the dot. The principle of a moving dot requires the measured object not to move relative to the microscope during measurement, and hence is not suitable for handheld use.

15

Summary of the invention

It is an object of the present invention to provide a scanner for obtaining the 3D surface geometry and surface color of the surface of an object, which does not require that some 2D images are recorded for determining the 3D surface geometry while other images are recorded for determining the surface color.

It is an object of the present invention to provide a scanner for obtaining the 3D surface geometry and surface color of the surface of an object, which obtains surface color and the 3D surface geometry simultaneously such that an alignment of data relating to 3D surface geometry and data relating to surface color is not required.

Disclosed is a scanner for obtaining 3D surface geometry and surface color of an object, the scanner comprising:

30

- a multichromatic light source configured for providing a probe light, and

- a color image sensor comprising an array of image sensor pixels for recording one or more 2D images of light received from said object,

where at least for a block of said image sensor pixels, both surface color and 3D surface geometry of a part of the object are derived at least partly from one 2D image recorded by said color image sensor

Disclosed is a scanner for obtaining 3D surface geometry and surface color of an object, the scanner comprising:

- a multichromatic light source configured for providing a probe light,
- 10 - a color image sensor comprising an array of image sensor pixels, and
- an optical system configured for guiding light received from the object to the color image sensor such that 2D images of said object can be recorded by said color image sensor;

wherein the scanner is configured for acquiring a number of said 2D images of a part of the object and for deriving both surface color and 3D surface geometry of the part of the object from at least one of said recorded 2D images at least for a block of said image sensor pixels, such that the surface color and 3D surface geometry are obtained concurrently by the scanner.

20 Disclosed is a scanner for obtaining 3D surface geometry and surface color of an object, the scanner comprising:

- a multichromatic light source configured for providing a probe light;
- a color image sensor comprising an array of image sensor pixels, where the image sensor is arranged to record 2D images of light received from the object; and

- an image processor configured for deriving both surface color and 3D surface geometry of at least a part of the object from at least one of said 2D images recorded by the color image sensor.

5 Disclosed is a scanner system for obtaining 3D surface geometry and surface color of an object, said scanner system comprising

- a scanner according to any of the embodiments, where the scanner is configured for deriving surface color and 3D surface geometry of the object, and optionally for obtaining a partial or full 3D surface geometry of the part of the object; and
- 10 - a data processing unit configured for post-processing 3D surface geometry and/or surface color readings from the color image sensor, or for post-processing the obtained partial or full 3D surface geometry.

15 In some embodiments, the data processing unit comprises a computer readable medium on which is stored computer implemented algorithms for performing said post-processing.

In some embodiments, the data processing unit is integrated in a cart or a personal computer.

20 Disclosed is a method of obtaining 3D surface geometry and surface color of an object, the method comprising:

- providing a scanner or scanner system according to any of the embodiments;
- illuminating the surface of said object with probe light from said multichromatic light source;
- 25 - recording one or more 2D images of said object using said color image sensor; and

- deriving both surface color and 3D surface geometry of a part of the object from at least some of said recorded 2D images at least for a block of said image sensor pixels, such that the surface color and 3D surface geometry are obtained concurrently by the scanner.

5

The present invention is a significant improvement over the state of the art in that only a single image sensor and a single multichromatic light source is required, and that surface color and 3D surface geometry for at least a part of the object can be derived from the same image or images, which also means that alignment of
10 color and 3D surface geometry is inherently perfect. In the scanner according to the present invention, there is no need for taking into account or compensating for relative motion of the object and scanner between obtaining 3D surface geometry and surface color. Since the 3D surface geometry and the surface color are
15 obtained at precisely the same time, the scanner automatically maintains its spatial disposition with respect to the object surface while obtaining the 3D surface geometry and the surface color. This makes the scanner of the present invention suitable for handheld use, for example as an intraoral scanner, or for scanning moving objects.

In the context of the present invention, the phrase "surface color" may refer to the
20 apparent color of an object surface and thus in some cases, such as for semi-transparent or semi-translucent objects such as teeth, be caused by light from the object surface and/or the material below the object surface, such as material immediately below the object surface.

In some embodiments, the 3D surface geometry and the surface color are both
25 determined from light recorded by the color image sensor.

In some embodiments, the light received from the object originates from the multichromatic light source, i.e. it is probe light reflected or scattered from the surface of the object.

In some embodiments, the light received from the object is fluorescence excited by the probe light from the multichromatic light source, i.e. fluorescence emitted by fluorescent materials in the object surface.

5 In some embodiments, a second light source is used for the excitation of fluorescence while the multichromatic light source provides the light for obtaining the geometry and color of the object.

10 In some embodiments, the scanner comprises a first optical system, such as an arrangement of lenses, for transmitting the probe light from the multichromatic light source towards an object and a second optical system for imaging light received from the object at the color image sensor.

15 In some embodiments, only one optical system images the probe light onto the object and images the object, or at least a part of the object, onto the color image sensor, preferably along the same optical axis, however along opposite optical paths. The scanner may comprise at least one beam splitter located in the optical path, where the beam splitter is arranged such that it directs the probe light from the multichromatic light source towards the object while it directs light received from the object towards the color image sensor.

20 In some embodiments, the surface color and 3D surface geometry of the part of the object are derived from a plurality of recorded 2D images. In that case, both surface color and 3D surface geometry of the part of the object can be derived from a number of the plurality of recorded 2D images.

Several scanning principles are suitable for this invention, such as triangulation and focus scanning.

25 In some embodiments, the scanner is a focus scanner configured for obtaining a stack of 2D images of the object from a number of different focus plane positions. In some focus scanning embodiments, the focus plane is adjusted in such a way that the image of e.g. a spatial pattern projected by the light source on the probed object is shifted along the optical axis while recording 2D images at a number of focus plane positions such that said stack of recorded 2D images can be obtained

for a given position of the scanner relative to the object. The focus plane position may be varied by means of at least one focus element, e.g., a moving focus lens.

In some focus scanner embodiments, the scanner comprises means for incorporating a spatial pattern in said probe light and means for evaluating a correlation measure at each focus plane position between at least one image pixel and a weight function, where the weight function is determined based on information of the configuration of the spatial pattern. Determining in-focus information may then relate to calculating a correlation measure of the spatially structured light signal provided by the pattern with the variation of the pattern itself (which we term reference) for every location of the focus plane and finding the location of an extremum of this series. In some embodiments, the pattern is static. Such a static pattern can for example be realized as a chrome-on-glass pattern.

One way to define the correlation measure mathematically with a discrete set of measurements is as a dot product computed from a signal vector, $I = (I_1, \dots, I_n)$, with $n > 1$ elements representing sensor signals and a reference vector, $f = (f_1, \dots, f_n)$, of reference weights. The correlation measure A is then given by

$$A = f \cdot I = \sum_{i=1}^n f_i I_i$$

The indices on the elements in the signal vector represent sensor signals that are recorded at different pixels, typically in a block of pixels. The reference vector f can be obtained in a calibration step.

By using knowledge of the optical system used in the scanner, it is possible to transform the location of an extremum of the correlation measure, i.e., the focus plane into depth data information, on a pixel block basis. All pixel blocks combined thus provide an array of depth data. In other words, depth is along an optical path that is known from the optical design and/or found from calibration, and each block of pixels on the image sensor represents the end point of an optical path. Therefore, depth along an optical path, for a bundle of paths, yields a 3D surface geometry within the field of view of the scanner.

It can be advantageous to smooth and interpolate the series of correlation measure values, such as to obtain a more robust and accurate determination of the location of the maximum. For example, a polynomial can be fitted to the values of A for a pixel block over several images on both sides of the recorded maximum, and a location of a deducted maximum can be found from the maximum of the fitted polynomial, which can be in between two images.

Color for a block of pixels is at least partially derived from the same image from which 3D geometry is derived. In case the location of the maximum of A is represented by an image, then also color is derived from that same image. In case the location of the maximum of A is found by interpolation to be between two images, then at least one of those two images should be used to derive color, or both images using interpolation for color also. It is also possible to average color data from more than two images used in the determination of the location of the maximum of the correlation measure, or to average color from a subset or superset of multiple images used to derive 3D surface geometry. In any case, some image sensor pixels readings are used to derive both surface color and 3D surface geometry for at least a part of the scanned object.

Typically, there are three color filters, so the overall color is composed of three contributions, such as red, green, and blue, or cyan, magenta, and yellow. Note that color filters typically allow a range of wavelengths to pass, and there is typically cross-talk between filters, such that, for example, some green light will contribute to the intensity measured in pixels with red filters.

For an image sensor with a color filter array, a color component c_j within a pixel block can be obtained as

$$c_j = \sum_{i=1}^n g_{j,i} I_i$$

where $g_{j,i} = 1$ if pixel i has a filter for color c_j , 0 otherwise. For an RGB filter array like in a Bayer pattern, j is one of red, green, or blue. Further weighting of the individual color components, i.e., color calibration, may be required to obtain natural color data, typically as compensation for varying filter efficiency,

illumination source efficiency, and different fraction of color components in the filter pattern. The calibration may also depend on focus plane location and/or position within the field of view, as the mixing of the light source component colors may vary with those factors.

5 In some embodiments, color is obtained for every pixel in a pixel block. In sensors with a color filter array or with other means to separate colors such as diffractive means, depending on the color measured with a particular pixel, an intensity value for that color is obtained. In other words, in this case a particular pixel has a color value only for one color. Recently developed color image sensors allow
10 measurement of several colors in the same pixel, at different depths in the substrate, so in that case, a particular pixel can yield intensity values for several colors. In summary, it is possible to obtain a resolution of the surface color data that is inherently higher than that of the 3D geometry data.

In the embodiments where color resolution is higher than 3D geometry resolution,
15 a pattern will be visible when at least approximately in focus, which preferably is the case when color is derived. The image can be filtered such as to visually remove the pattern, however at a loss of resolution. In fact, it can be advantageous to be able to see the pattern for the user. For example in intraoral scanning, it may be important to detect the position of a margin line, the rim or
20 edge of a preparation. The image of the pattern overlaid on the 3D geometry of this edge is sharper on a side that is seen approximately perpendicular, and more blurred on the side that is seen at an acute angle. Thus, a user, who in this example typically is a dentist or dental technician, can use the difference in sharpness to more precisely locate the position of the margin line than may be
25 possible from examining the 3D surface geometry alone.

High spatial contrast of the in-focus pattern image on the object is desirable to obtain a good signal to noise ratio of the correlation measure on the color image sensor. Improved spatial contrast can be achieved by preferential imaging of the specular surface reflection from the object on the color image sensor. Thus, some
30 embodiments of the invention comprise means for preferential/selective imaging of specularly reflected light. This may be provided if the scanner further comprises

means for polarizing the probe light, for example by means of at least one polarizing beam splitter.

In some embodiments, the polarizing optics is coated such as to optimize preservation of the circular polarization of a part of the spectrum of the
5 multichromatic light source that is used for obtaining the 3D surface geometry.

The scanner according to the invention may further comprise means for changing the polarization state of the probe light and/or the light received from the object. This can be provided by means of a retardation plate, preferably located in the optical path. In some embodiments of the invention the retardation plate is a
10 quarter wave retardation plate.

Especially for intraoral applications, the scanner can have an elongated tip, with means for directing the probe light and/or imaging an object. This may be provided by means of at least one folding element. The folding element could be a light reflecting element such as a mirror or a prism.

15 For a more in-depth description of the above aspects of this invention, see WO2010145669.

The invention disclosed here comprises a multichromatic light source, for example a white light source, for example a multi-die LED.

Light received from the scanned object, such as probe light returned from the
20 object surface or fluorescence generated by the probe light by exciting fluorescent parts of the object, is recorded by a color image sensor. In some embodiments, the color image sensor comprises a color filter array such that every pixel in the color image sensor is a color-specific filter. The color filters are preferably arranged in a regular pattern, for example where the color filters are arranged
25 according to a Bayer color filter pattern. The image data thus obtained are used to derive both 3D surface geometry and surface color for each block of pixels. For a focus scanner utilizing a correlation measure, the 3D surface geometry may be found from an extremum of the correlation measure as described above.

In some embodiments, the 3D surface geometry is derived from light in a first part
30 of the spectrum of the probe light provided by the multichromatic light source.

Preferably, the color filters are aligned with the image pixels, preferably such that each pixel has a color filter for a particular color only.

In some embodiments, the color filter array is such that its proportion of pixels with color filters that match the first part of the spectrum is larger than 50%.

- 5 In some embodiments, the scanner is configured to derive the surface color with a higher resolution than the 3D surface geometry.

In some embodiments, the higher surface color resolution is achieved by demosaicing, where color values for pixel blocks may be demosaiced to achieve an apparently higher resolution of the color image than is present in the 3D
10 surface geometry. The demosaicing may operate on pixel blocks or individual pixels.

In case a multi-die LED or another illumination source comprising physically or optically separated light emitters is used, it is preferable to aim at a Köhler type illumination in the scanner, i.e. the illumination source is defocused at the object
15 plane in order to achieve uniform illumination and good color mixing for the entire field of view. In case color mixing is not perfect and varies with focal plane location, color calibration of the scanner will be advantageous.

It can be preferable to compute the 3D surface geometry only from pixels with one or two kinds of color filters. A single color requires no achromatic optics and is thus
20 provides for a scanner that is easier and cheaper to build. Furthermore, folding elements can generally not preserve the polarization state for all colors equally well. When only some color(s) is/are used to compute 3D surface geometry, the reference vector f will contain zeros for the pixels with filters for the other color(s). Accordingly, the total signal strength is generally reduced, but for large enough
25 blocks of pixels, it is generally still sufficient. Preferentially, the pixel color filters are adapted for little cross-talk from one color to the other(s). Note that even in the embodiments computing geometry from only a subset of pixels, color is preferably still computed from all pixels.

To obtain a full 3D surface geometry and color representation of an object, i.e. a
30 colored full 3D surface geometry of said part of the object surface, typically several

partial representations of the object have to be combined, where each partial representation is a view from substantially the same relative position of scanner and object. In the present invention, a view from a given relative position preferably obtains the 3D geometry and color of the object surface as seen from
5 that relative position.

For a focus scanner, a view corresponds to one pass of the focusing element(s), i.e. for a focus scanner each partial representation is the 3D surface geometry and color derived from the stack of 2D images recorded during the pass of the focus plane position between its extremum positions.

10 The 3D surface geometry found for various views can be combined by algorithms for stitching and registration as widely known in the literature, or from known view positions and orientations, for example when the scanner is mounted on axes with encoders. Color can be interpolated and averaged by methods such as texture weaving, or by simply averaging corresponding color components in multiple views
15 of the same location on the 3D surface. Here, it can be advantageous to account for differences in apparent color due to different angles of incidence and reflection, which is possible because the 3D surface geometry is also known. Texture weaving is described by e.g. Callieri M, Cignoni P, Scopigno R. "Reconstructing textured meshes from multiple range rgb maps". VMV 2002, Erlangen, Nov 20-22,
20 2002.

In some embodiments, the scanner and/or the scanner system is configured for generating a partial representation of the object surface based on the obtained surface color and 3D surface geometry.

25 In some embodiments, the scanner and/or the scanner system is configured for combining partial representations of the object surface obtained from different relative positions to obtain a full 3D surface geometry and color representation of the part of the object.

In some embodiments, the combination of partial representations of the object to obtain the full 3D surface geometry and color representation comprises computing
30 the color in each surface point as a weighted average of corresponding points in all overlapping partial 3D surface geometries at that surface point. The weight of

each partial presentation in the sum may be determined by several factors, such as the presence of saturated pixel values or the orientation of the object surface with respect to the scanner.

Such a weighted average is advantageous in cases where some scanner positions and orientations relative to the object will give a better estimate of the actual color than other positions and orientations. If the illumination of the object surface is uneven this can to some degree also be compensated for by weighting the best illuminated parts higher.

In some embodiments, the scanner comprises an image processor configured for performing a post-processing of the 3D surface geometry, the surface color readings, or the derived partial or full 3D surface geometries of the object. The scanner may be configured for performing the combination of the partial representations using e.g. computer implemented algorithms executed by an image processor of the scanner.

The scanner system may be configured for performing the combination of the partial representations using e.g. computer implemented algorithms executed by the data processing unit as part of the post-processing of the 3D surface geometry, surface color, partial 3D geometry and/or full 3D geometry, i.e. the post-processing comprises computing the color in each surface point as a weighted average of corresponding points in all overlapping partial 3D surface geometries at that surface point.

Saturated pixel values should preferably have a low weight to reduce the effect of highlights on the recording of the surface color. The color for a given part of the surface should preferably be determined primarily from 2D images where the color can be determined precisely which is not the case when the pixel values are saturated.

In some embodiments, the scanner and/or scanner system is configured for detecting saturated pixels in the recorded 2D images and for mitigating or removing the error in the obtained color caused by the pixel saturation. The error caused by the saturated pixel may be mitigated or removed by assigning a low weight to the saturated pixel in the weighted average.

Specularly reflected light has the color of the light source rather than the color of the object surface. If the object surface is not a pure white reflector then specular reflections can hence be identified as the areas where the pixel color closely matches the light source color. When obtaining the surface color it is therefore
5 advantageous to assign a low weight to pixels or pixel groups whose color values closely match the color of the multichromatic light source in order to compensate for such specular reflections.

Specular reflections may also be a problem when intra orally scanning a patient's set of teeth since teeth rarely are completely white. It may hence be advantageous
10 to assume that for pixels where the readings from the color images sensor indicate that the surface of the object is a pure white reflector, the light recorded by this pixel group is caused by a specular reflection from the teeth or the soft tissue in the oral cavity and accordingly assign a low weight to these pixels to compensate for the specular reflections.

15 In some embodiments, the compensation for specular reflections from the object surface is based on information derived from a calibration of the scanner in which a calibration object e.g. in the form of a pure white reflector is scanned. The color image sensor readings then depend on the spectrum of the multichromatic light source and on the wavelength dependence of the scanner's optical system caused
20 by e.g. a wavelength dependent reflectance of mirrors in the optical system. If the optical system guides light equally well for all wavelengths of the multichromatic light source, the color image sensor will record the color (also referred to as the spectrum) of the multichromatic light source when the pure white reflector is scanned.

25 In some embodiments, compensating for the specular reflections from the surface is based on information derived from a calculation based on the wavelength dependence of the scanner's optical system, the spectrum of the multichromatic light source and a wavelength dependent sensitivity of the color image sensor. In some embodiments, the scanner comprises means for optically suppressing
30 specularly reflected light to achieve better color measurement. This may be provided if the scanner further comprises means for polarizing the probe light, for example by means of at least one polarizing beam splitter.

When scanning inside an oral cavity there may be red ambient light caused by probe light illumination of surrounding tissue, such as the gingiva, palette, tongue or buccal tissue. In some embodiments, the scanner and/or scanner system is hence configured for suppressing the red component in the recorded 2D images.

5 In some embodiments, the scanner and/or scanner system is configured for comparing the color of sections of the recorded 2D images and/or of the partial presentations of the object with predetermined color ranges for teeth and for oral tissue, respectively, and for suppressing the red component of the recorded color for sections where the color is not in either one of the two predetermined color
10 ranges. The teeth may e.g. be assumed to be primarily white with one ratio between the intensity of the different components of the recorded image, e.g. with one ratio between the intensity of the red component and the intensity of the blue and/or green components in a RGB configuration, while oral tissue is primarily reddish with another ratio between the intensity of the components. When a color
15 recorded for a region of the oral cavity shows a ratio which differs from both the predetermined ratio for teeth and the predetermined ratio for tissue, this region is identified as a tooth region illuminated by red ambient light and the red component of the recorded image is suppressed relative to the other components, either by reducing the recorded intensity of the red signal or by increasing the recorded
20 intensities of the other components in the image.

In some embodiments, the color of points with a surface normal directly towards the scanner are weighted higher than the color of points where the surface normal is not directed towards the scanner. This has the advantage that points with a surface normal directly towards the scanner will to a higher degree be illuminated
25 by the white light from the scanner and not by the ambient light.

In some embodiments, the color of points with a surface normal directly towards the scanner are weighted lower if associated with specular reflections.

In some embodiments the scanner is configured for simultaneously compensating for different effects, such as compensating for saturated pixels and/or for specular
30 reflections and/or for orientation of the surface normal. This may be done by generally raising the weight for a selection of pixels or pixel groups of a 2D image

and by reducing the weight for a fraction of the pixels or pixel groups of said selection.

In some embodiments, the method comprises a processing of recorded 2D images, partial or full 3D representations of the part of the object, where said

5 processing comprises

- compensating for pixel saturation by omitting or reducing the weight of saturated pixels when deriving the surface color, and/or
- compensating for specular reflections when deriving the surface color by omitting or reducing the weight of pixels whose color values closely
10 matches the light source color, and/or
- compensating for red ambient light by comparing color of the 2D images with predetermined color ranges, and suppressing the red component of the recorded color if this is not within a predetermined color range.

15 Disclosed is a method of using a scanner of this invention to display color texture on 3D surface geometry. It is advantageous to display the 2D color data as a texture on the 3D surface geometry, for example on a computer screen. The combination of color and geometry is a more powerful conveyor of information than either type of data alone. For example, dentists can more easily differentiate
20 between different types of tissue. In the rendering of the 3D surface geometry, appropriate shading can help convey the 3D surface geometry on the texture, for example with artificial shadows revealing sharp edges better than texture alone could do.

When the multichromatic light source is a multi-die LED or similar, the scanner of
25 this invention can also be used to detect fluorescence. Disclosed is a method of using the scanner of the invention to display fluorescence on 3D surface geometry.

In some embodiments, the scanner is configured for exciting fluorescence on said object by illuminating it with only a subset of the LED dies in the multi-die LED,

and where said fluorescence is recorded by only or preferentially reading out only those pixels in the color image sensor that have color filters at least approximately matching the color of the fluoresced light, i.e. measuring intensity only in pixels of the image sensors that have filters for longer-wavelength light. In other words, the scanner is capable of selectively activating only a subset of the LED dies in the multi-die LED and of only recording or preferentially reading out only those pixels in the color image sensor that have color filters at a higher wavelength than that of the subset of the LED dies, such that light emitted from the subset of LED dies can excite fluorescent materials in the object and the scanner can record the fluorescence emitted from these fluorescent materials. The subset of the dies preferably comprises one or more LED dies which emits light within the excitation spectrum of the fluorescent materials in the object, such as an ultraviolet, a blue, a green, a yellow or a red LED die. Such fluorescence measurement yields a 2D data array much like the 2D color image, however unlike the 2D image it cannot be taken concurrently with the 3D surface geometry. For a slow-moving scanner, and/or with appropriate interpolation, the fluorescence image can still be overlaid the 3D surface geometry. It is advantageous to display fluorescence on teeth because it can help detect caries and plaque.

In some embodiments, the processing means comprises a microprocessor unit configured for extracting the 3D surface geometry from 2D images obtained by the color image sensor and for determining the surface color from the same images.

Disclosed is a method of using a scanner of this invention to average color and/or 3D surface geometry from several views, where each view represents a substantially fixed relative orientation of scanner and object.

Disclosed is a method using a scanner of this invention to combine color and/or 3D surface geometry from several views, where each view represents a substantially fixed relative orientation of scanner and object, such as to achieve a more complete coverage of the object than would be possible in a single view.

Brief description of drawings

Fig. 1 shows a handheld embodiment of the scanner according to the invention.

Fig. 2 shows prior art pattern generating means and associated reference weights.

Fig. 3 shows a pattern generating means and associated reference weights according to the present invention.

5 Fig. 4 shows a color filter array according to the present invention

The scanner embodiment illustrated in fig. 1 is a hand-held scanner with components inside the housing 100. The scanner comprises a tip which can be entered into a cavity, a multichromatic light source in the form of a multi-die LED
10 101, pattern generation means 130 for incorporating a spatial pattern in the probe light, a beam splitter 140, an image acquisition means 180 including an image sensor 181, electronics and potentially other elements, an optical system typically comprising at least one lens, the object being scanned 200, and the image sensor.
15 The light from the light source 101 travels back and forth through the optical system 150. During this passage the optical system images the pattern 130 onto the object being scanned 200 and further images the object being scanned onto the image sensor 181.

The image sensor 181 has a color filter array 1000. Although drawn as a separate entity because of its importance in the invention, the color filter array is typically
20 integrated with the image sensor, with a single-color filter for every pixel.

The lens system includes a focusing element 151 which can be adjusted to shift the focal imaging plane of the pattern on the probed object 200. In the example embodiment, a single lens element is shifted physically back and forth along the optical axis.

25 As a whole, the optical system provides an imaging of the pattern onto the object being probed and from the object being probed to the camera.

The device may include polarization optics 160. Polarization optics can be used to selectively image specular reflections and block out undesired diffuse signal from sub-surface scattering inside the scanned object. The beam splitter 140 may also

have polarization filtering properties. It can be advantageous for optical elements to be anti-reflection coated.

The device may include folding optics, a mirror 170, which directs the light out of the device in a direction different to the optical axis of the lens system, e.g. in a direction perpendicular to the optical axis of the lens system.

There may be additional optical elements in the scanner, for example one or more condenser lens in front of the light source 101.

In the example embodiment, the LED 101 is a multi-die LED with two green, one red, and one blue die. Only the green portion of the light is used for obtaining the 3D surface geometry. Accordingly, the mirror 170 is coated such as to optimize preservation of the circular polarization of the green light, and not that of the other colors. Note that during scanning all dies within the LED are active, i.e., emitting light, so the scanner emits apparently white light onto the scanned object 200. The LED may emit light at the different colors with different intensities such that e.g. one color is more intense than the other colors. This may be desired in order to reduce cross-talk between the readings of the different color signals in the color image sensor. In case that the intensity of e.g. the red and blue diodes in a RGB system is reduced, the apparently white light emitted by the light source will appear greenish-white.

Figure 2 shows an example of prior art pattern generation means 130 that is applied as a static pattern in a spatial correlation embodiment of WO20101455669, as imaged on a monochromatic image sensor 180. The pattern can be a chrome-on-glass pattern. Only a portion of the pattern is shown, namely one period. This period is represented by a pixel block of 6 by 6 image pixels, and 2 by 2 pattern fields. The fields drawn in gray in Fig. 2 (a) are in actuality black because the pattern mask is opaque for these fields; gray was only chosen for visibility and thus clarity of the Figure. Figure 2(b) illustrates the reference weights f for computing the spatial correlation measure A for the pixel block, where $n = 6 \times 6 = 36$, such that

$$A = \sum_{i=1}^n f_i I_i$$

where I are the intensity values measured in the 36 pixels in the pixel block for a given image. Note that perfect alignment between image sensor pixels and pattern fields is not required, but gives the best signal for the 3D surface geometry measurement.

- 5 Figure 3 shows the extension of the principle in Figure 2 for the present invention. The pattern is the same as in Figure 2 and so is the image sensor geometry. However, the image sensor is a color image sensor with a Bayer color filter array. In Figure 2 (a), pixels marked "B" have a blue color filter, while "G" indicates green and "R" red pixel filters, respectively. Figure 2 (b) shows the corresponding
 10 reference weights f . Note that only green pixels have a non-zero value. This is so because only the green fraction of the spectrum is used for obtaining the 3D surface geometry.

For the pattern / color filter combination of Figure 3, a color component c_j within a pixel block can be obtained as

$$c_j = \sum_{i=1}^n g_{j,i} I_i$$

- 15 where $g_{j,i} = 1$ if pixel i has a filter for color c_j , 0 otherwise. For an RGB color filter array like in the Bayer pattern, j is one of red, green, or blue. Further weighting of the individual color components, i.e., color calibration, may be required to obtain natural color data, typically as compensation for varying filter efficiency, illumination source efficiency, and different fraction of color components in the filter
 20 pattern. The calibration may also depend on focus plane location and/or position within the field of view, as the mixing of the LED's component colors may vary with those factors.

- Figure 4 shows an alternative color filter array with a higher fraction of green pixels than in the Bayer pattern. Assuming that only the green portion of the illumination
 25 is used to obtain the 3D surface geometry, the filter of Figure 4 will potentially provide a better quality of the obtained 3D surface geometry than a Bayer pattern

filter, at the expense of poorer color representation. The poorer color representation will however in many cases still be sufficient while the improved quality of the obtained 3D surface geometry often is very advantageous.

5

Claims

1. A scanner for obtaining 3D surface geometry and surface color of an object, the scanner comprising:
 - 5 - a multichromatic light source configured for providing a probe light, and
 - a color image sensor comprising an array of image sensor pixels for recording one or more 2D images of light received from said object, where at least for a block of said image sensor pixels, both surface color and 3D surface geometry of a part of the object are derived at least
10 partly from one 2D image recorded by said color image sensor.
2. A scanner according to claim 1, wherein the surface color and 3D surface geometry of the part of the object are derived from a plurality of recorded 2D images, and where for a number of the plurality of recorded 2D images
15 both surface color and 3D surface geometry of the part of the object are derived.
3. A scanner according to any of the preceding claims where the scanner is a focus scanner configured for obtaining a stack of 2D images of the object
20 from a number of different focus plane positions.
4. A scanner according to the preceding claim where the scanner comprises means for incorporating a spatial pattern in said probe light and means for evaluating a correlation measure at each focus plane position between at
25 least one image pixel and a weight function, where the weight function is determined based on information of the configuration of the spatial pattern.
5. A scanner according to the preceding claim and where the spatial pattern is static.
30
6. A scanner according to any of the preceding claims where the color image sensor comprises a color filter array.

7. A scanner according to any of the preceding claims where the color filters of the array are arranged according to a Bayer color filter pattern.
- 5 8. A scanner according to any of the preceding claims where the 3D surface geometry is derived from light in a first part of the spectrum provided by the multichromatic light source
- 10 9. A scanner according to the preceding claim where the color filter array is such that its proportion of pixels with color filters that match the first part of the spectrum is larger than 50%.
- 15 10. A scanner according to any of the preceding claims where the multichromatic light source is a multi-die LED
- 20 11. A scanner according to any of the preceding claims where the scanner is configured to derive the surface color with a higher resolution than the 3D surface geometry
- 25 12. A scanner according to the preceding claim where the higher surface color resolution is achieved by demosaicing.
- 30 13. A scanner according to any of the preceding claims where the scanner is configured for exciting fluorescence on said object by illuminating it with only a subset of the LED dies in the multi-die LED, and where said fluorescence is recorded by only or preferentially reading out only those pixels in the color image sensor that have color filters at least approximately matching the color of the fluoresced light.
14. The scanner according to any of the preceding claims, wherein the scanner is configured for generating a partial representation of the part of the object surface based on the obtained surface color and 3D surface geometry, and for combining partial representations obtained from different relative

positions to obtain a full 3D surface geometry and color representation of the part of the object.

5 15. A scanner for obtaining 3D surface geometry and surface color of an object, the scanner comprising:

- a multichromatic light source configured for providing a probe light,
- a color image sensor comprising an array of image sensor pixels, and
- an optical system configured for guiding light received from the object to the color image sensor such that 2D images of said object can be recorded by said color image sensor;

10 wherein the scanner is configured for acquiring a number of said 2D images of a part of the object and for deriving both surface color and 3D surface geometry of the part of the object from at least one of said recorded 2D images at least for a block of said image sensor pixels, such that surface color and 3D surface geometry are obtained concurrently by the scanner.

15 16. A scanner for obtaining 3D surface geometry and surface color of an object, the scanner comprising:

- a multichromatic light source configured for providing a probe light;
- 20 - a color image sensor comprising an array of image sensor pixels, where the image sensor is arranged to record 2D images of light received from the object; and
- an image processor configured for deriving both surface color and 3D surface geometry of at least a part of the object from at least one of said 2D images recorded by the color image sensor.

25 17. A scanner system for obtaining 3D surface geometry and surface color of an object, said scanner system comprising

- a scanner according to any of the preceding claims, where the scanner is configured for deriving surface color and 3D surface geometry of the object, and optionally for obtaining a partial or full 3D surface geometry of the part of the object; and
- 5
- a data processing unit configured for post-processing 3D surface geometry and/or surface color readings from the color image sensor, or for post-processing the obtained partial or full 3D surface geometry.
18. The scanner system according to the preceding claim, wherein the post-processing comprises computing the color in each surface point as a
- 10 weighted average of corresponding points in all overlapping partial 3D surface geometries at that surface point.
19. The scanner system according to claim 17 or 18, wherein the scanner system is configured for detecting saturated pixels in the recorded 2D images and for mitigating or removing the error in the obtained color caused
- 15 by the pixel saturation.
20. The scanner system according to the preceding claim wherein the error caused by the saturated pixel is mitigated or removed by assigning a low weight to the saturated pixel in the weighted average.
21. The scanner system according to any of claims 17 to 20, wherein the
- 20 scanner system is configured for comparing the color of sections of the recorded 2D images and/or of the partial presentations of the object with predetermined color ranges for teeth and for oral tissue, and for suppressing the red component of the recorded color for sections where the color is not in one of the two predetermined color ranges.
- 25
22. A method of obtaining 3D surface geometry and surface color of an object, the method comprising:
- providing a scanner or scanner system according to any of the previous claims;

- illuminating the surface of said object with probe light from said multichromatic light source;
- recording one or more 2D images of said object using said color image sensor; and
- 5 - deriving both surface color and 3D surface geometry of a part of the object from at least some of said recorded 2D images at least for a block of said image sensor pixels, such that the surface color and 3D surface geometry are obtained concurrently by the scanner.

23. The method according to claim 22, wherein the method comprises a
10 processing of recorded 2D images, partial or full 3D representations of the part of the object, where said processing comprises

- compensating for pixel saturation by omitting or reducing the weight of saturated pixels when deriving the surface color, and/or
- 15 - compensating for red ambient light by comparing color of the 2D images with predetermined color ranges, and suppressing the red component of the recorded color if this is not within a predetermined color range.

Abstract

Disclosed is a scanner, a scanner system, a user interface and a method for obtaining 3D surface geometry and surface color of an object, the scanner comprising:

- 5 - a multichromatic light source configured for providing a probe light, and
- a color image sensor comprising an array of image sensor pixels for recording one or more 2D images of light received from said object, where at least for a block of said image sensor pixels, both surface color and 3D surface geometry of a part of the object are derived at least
- 10 partly from one 2D image recorded by said color image sensor.

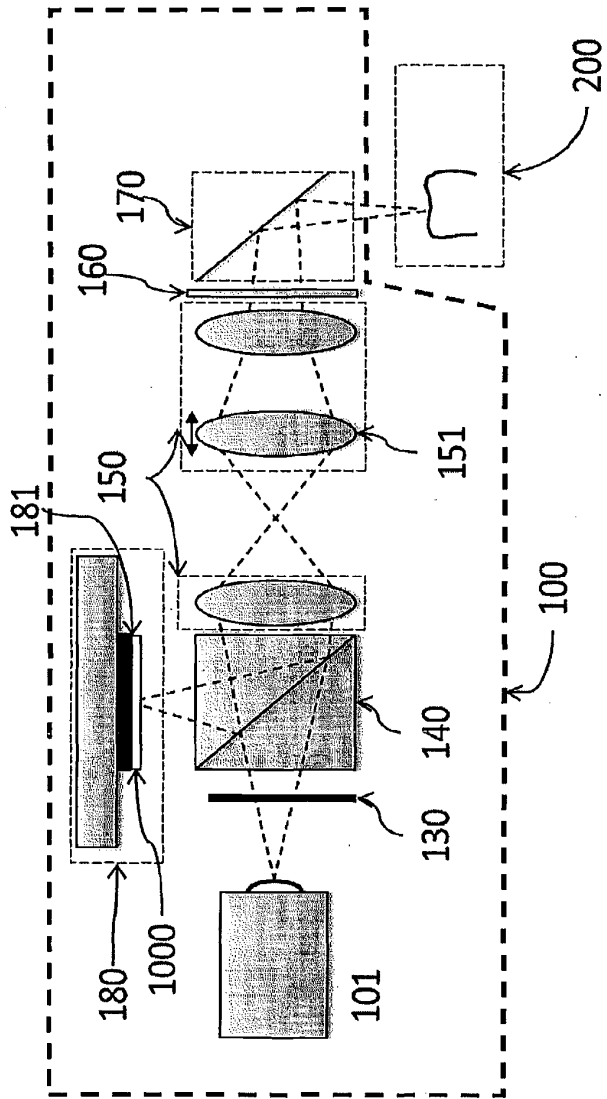
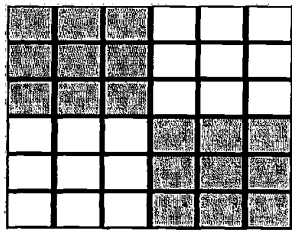
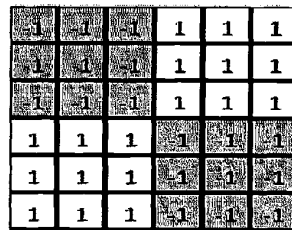

Fig. 1

2/3



(a)



(b)

Fig. 2

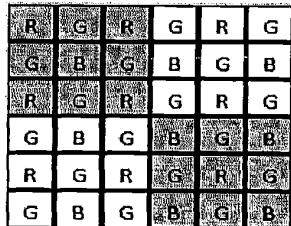

(a)

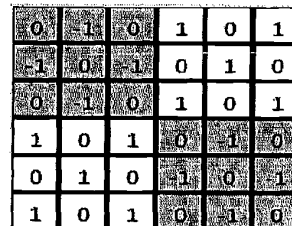

(b)

Fig. 3

3/3

G	G	G	G	G	G
G	R	G	G	R	G
G	G	G	G	G	G
G	G	G	G	G	G
G	B	G	G	B	G
G	G	G	G	G	G

Fig. 4

Application Data Sheet 37 CFR 1.76		Attorney Docket Number	0079124-000065
		Application Number	Unassigned
Title of Invention	FOCUS SCANNING APPARATUS RECORDING COLOR		

Secrecy Order 37 CFR 5.2:

Secrecy Order in Parent Appl.?: No

Inventor Information:

Inventor 1 – Legal Name

Given Name:: Bo

Middle Name::

Family Name:: ESBECH

Suffix::

Residence Information (Select One) US Residency Non US Residency Active US Military Service

City:: Copenhagen S

State/Province::

Country:: Denmark

Mailing Address of Inventor

Street:: Edvard Thomsens Vej 7A, 2.th

City:: Copenhagen S

State/Province::

Country:: Denmark

Postal/Zip Code:: DK-2300

Application Data Sheet 37 CFR 1.76		Attorney Docket Number	0079124-000065
		Application Number	Unassigned
Title of Invention	FOCUS SCANNING APPARATUS RECORDING COLOR		

Inventor 2 – Legal Name

Given Name:: Christian
Middle Name:: Romer
Family Name:: ROSBERG
Suffix::

Residence Information (Select One) US Residency Non US Residency Active US Military Service

City:: Copenhagen V
State/Province::
Country:: Denmark

Mailing Address of Inventor

Street:: Dybbølsgade 50 3. 29
City:: Copenhagen V
State/Province::
Country:: Denmark
Postal/Zip Code:: DK-1721

Application Data Sheet 37 CFR 1.76		Attorney Docket Number	0079124-000065
		Application Number	Unassigned
Title of Invention	FOCUS SCANNING APPARATUS RECORDING COLOR		

Inventor 3 – Legal Name

Given Name:: Mike
Middle Name::
Family Name:: VAN DER POEL
Suffix::

Residence Information (Select One) US Residency Non US Residency Active US Military Service

City:: Copenhagen
State/Province::
Country:: Denmark

Mailing Address of Inventor

Street:: Rævebakkevej 35B
City:: Copenhagen
State/Province::
Country:: Denmark
Postal/Zip Code:: DK-2610

Application Data Sheet 37 CFR 1.76		Attorney Docket Number	0079124-000065
		Application Number	Unassigned
Title of Invention	FOCUS SCANNING APPARATUS RECORDING COLOR		

Inventor 4 – Legal Name

Given Name:: Rasmus

Middle Name::

Family Name:: KJÆR

Suffix::

Residence Information (Select One) US Residency Non US Residency Active US Military Service

City:: Copenhagen K

State/Province::

Country:: Denmark

Mailing Address of Inventor

Street:: Nørre Søgade 21, 1. sal

City:: Copenhagen K

State/Province::

Country:: Denmark

Postal/Zip Code:: DK-1370

Application Data Sheet 37 CFR 1.76		Attorney Docket Number	0079124-000065
		Application Number	Unassigned
Title of Invention	FOCUS SCANNING APPARATUS RECORDING COLOR		

Inventor 5 – Legal Name

Given Name:: Michael

Middle Name::

Family Name:: VINTHER

Suffix::

Residence Information (Select One) US Residency Non US Residency Active US Military Service

City:: Copenhagen S

State/Province::

Country:: Denmark

Mailing Address of Inventor

Street:: Tom Kristensens Vej 34, 4.tv

City:: Copenhagen S

State/Province::

Country:: Denmark

Postal/Zip Code:: DK-2300

Application Data Sheet 37 CFR 1.76		Attorney Docket Number	0079124-000065
		Application Number	Unassigned
Title of Invention	FOCUS SCANNING APPARATUS RECORDING COLOR		

Inventor 6 – Legal Name

Given Name:: Karl
Middle Name:: Josef
Family Name:: HOLLENBECK
Name Suffix::

Residence Information (Select One) US Residency Non US Residency Active US Military Service

City:: Copenhagen Ø
State/Province::
Country:: Denmark

Mailing Address of Inventor

Street:: Ribegade 12, 3. th.
City:: Copenhagen Ø
State/Province::
Country:: Denmark
Postal/Zip Code:: DK-2100

Application Data Sheet 37 CFR 1.76		Attorney Docket Number	0079124-000065
		Application Number	Unassigned
Title of Invention	FOCUS SCANNING APPARATUS RECORDING COLOR		

Correspondence Information:

Correspondence Customer Number:: 21839

Application Information:

Title:: FOCUS SCANNING APPARATUS RECORDING COLOR

Attorney Docket Number:: 0079124-000065

Small Entity?:: Yes

Application Type:: Provisional

Subject Matter:: Utility

Suggested Class (if any)::

Sub Class (if any)::

Suggested Technology Center (if any)::

Total Number of Drawing Sheets (if any):: 3

Suggested Figure for Publication (if any)::

Publication Information:

Request for Early Publication?:: No

Request for Non-Publication?:: No

Representative Information:

Representative Customer Number:: 21839

Application Data Sheet 37 CFR 1.76		Attorney Docket Number	0079124-000065
		Application Number	Unassigned
Title of Invention	FOCUS SCANNING APPARATUS RECORDING COLOR		

Domestic Benefit/National Stage Information:

Prior Application Status

Application Number:: Continuity Type::

Prior Application Number::

Filing Date (YYYY-MM-DD)::

Foreign Priority Information:

Application Number:: Country::

Filing Date (YYYY-MM-DD)::

Priority Claimed::

Authorization to Permit Access:

Authorization to Permit Access to the Instant Application by the Participating Offices

If checked, the undersigned hereby grants the USPTO authority to provide the European Patent Office (EPO), the Japan Patent Office (JPO), the Korean Intellectual Property Office (KIPO), the World Intellectual Property Office (WIPO), and any other intellectual property offices in which a foreign application claiming priority to the instant patent application is filed access to the instant patent application. See 37 CFR 1.14(c) and (h). This box should not be checked if the applicant does not wish the EPO, JPO, KIPO, WIPO, or other intellectual property office in which a foreign application claiming priority to the instant patent application is filed to have access to the instant patent application.

In accordance with 37 CFR 1.14(h)(3), access will be provided to a copy of the instant patent application with respect to: 1) the instant patent application-as-filed; 2) any foreign application to which the instant patent application claims priority under 35 U.S.C. 119(a)-(d) if a copy of the foreign application that satisfies the certified copy requirement of 37 CFR 1.55 has been filed in the instant patent application; and 3) any U.S. application-as-filed from which benefit is sought in the instant patent application.

In accordance with 37 CFR 1.14(c), access may be provided to information concerning the date of filing this Authorization.

Application Data Sheet 37 CFR 1.76		Attorney Docket Number	0079124-000065
		Application Number	Unassigned
Title of Invention	FOCUS SCANNING APPARATUS RECORDING COLOR		

Applicant Information:

Providing assignment information in this section does not substitute for compliance with any requirement of part 3 of Title 37 of CFR to have an assignment recorded by the Office.

Applicant 1

If the applicant is the inventor (or the remaining joint inventor or inventors under 37 CFR 1.45), this section should not be completed. The information to be provided in this section is the name and address of the legal representative who is the applicant under 37 CFR 1.43; or the name and address of the assignee, person to whom the inventor is under an obligation to assign the invention, or person who otherwise shows sufficient proprietary interest in the matter who is the applicant under 37 CFR 1.46. If the applicant is an applicant under 37 CFR 1.46 (assignee, person to whom the inventor is obligated to assign, or person who otherwise shows sufficient proprietary interest) together with one or more joint inventors, then the joint inventor or inventors who are also the applicant should be identified in this section.

- Assignee
- Legal Representative under 35 U.S.C. 117
- Person to whom the inventor is obligated to assign
- Person who shows sufficient proprietary interest

If applicant is the legal representative, indicate the authority to file the patent application, the inventor is:

Name of the Deceased or Legally Incapacitated inventor:

If the assignee is an Organization check here

Mailing Address Information:

Organization Name:: 3Shape A/S
 Address 1:: Holmens Kanal 7, 4. sal
 Address 2::
 City:: Copenhagen K
 State/Province::
 Country:: Denmark
 Postal/Zip Code:: DK-1060

Non-Applciant Assignee Information:

Providing assignment information in this section does not substitute for compliance with any requirement of part 3 of Title 37 of CFR to have an assignment recorded by the Office.

Application Data Sheet 37 CFR 1.76		Attorney Docket Number	0079124-000065
		Application Number	Unassigned
Title of Invention	FOCUS SCANNING APPARATUS RECORDING COLOR		

Assignee 1

Complete this section only if non-applicant assignee information is desired to be included on the patent application publication in accordance with 37 CFR 1.215(b). Do not include in this section an applicant under 37 CFR 1.46 (assignee, person to whom the inventor is obligated to assign, or person who otherwise shows sufficient proprietary interest), as the patent application publication will include the name of the applicant(s).

Organization Name::

Address 1::

Address 2::

City::

State/Province::

Country::

Postal/Zip Code::

Assignee 2

Complete this section only if non-applicant assignee information is desired to be included on the patent application publication in accordance with 37 CFR 1.215(b). Do not include in this section an applicant under 37 CFR 1.46 (assignee, person to whom the inventor is obligated to assign, or person who otherwise shows sufficient proprietary interest), as the patent application publication will include the name of the applicant(s).

Organization Name::

Address 1::

Address 2::

City::

State/Province::

Country::

Postal/Zip Code::

Signature:

Signature <i>William Rowland</i>	Date	2013-02-13
Printed Name William C. Rowland	Registration No.	30888

**DOCUMENT MADE AVAILABLE UNDER THE
PATENT COOPERATION TREATY (PCT)**

International application number:	PCT/EP2014/052842
International filing date:	13 February 2014 (13.02.2014)
Document type:	Certified copy of priority document
Document details:	Country/Office: US
	Number: 61/764,178
	Filing date: 13 February 2013 (13.02.2013)
Date of receipt at the International Bureau:	11 April 2014 (11.04.2014)

Remark: Priority document submitted or transmitted to the International Bureau in compliance with Rule 17.1(a),(b) or (b-bis)

(12) INTERNATIONAL APPLICATION PUBLISHED UNDER THE PATENT COOPERATION TREATY (PCT)

(19) World Intellectual Property
Organization
International Bureau



(10) International Publication Number
WO 2014/125037 A1

(43) International Publication Date
21 August 2014 (21.08.2014)

- (51) **International Patent Classification:**
A61C 9/00 (2006.01) G01B 11/25 (2006.01)
- (21) **International Application Number:**
PCT/EP2014/052842
- (22) **International Filing Date:**
13 February 2014 (13.02.2014)
- (25) **Filing Language:** English
- (26) **Publication Language:** English
- (30) **Priority Data:**
PA 2013 70077 13 February 2013 (13.02.2013) DK
61/764,178 13 February 2013 (13.02.2013) US
- (71) **Applicant:** 3SHAPE A/S [DK/DK]; Holmens Kanal 7, DK-1060 Copenhagen K (DK).
- (72) **Inventors:** ESBECH, Bo; Edvard Thomsens Vej 7A, 2.th, DK-2100 Copenhagen Ø (DK). ROSBERG, Christian Rømer; Dybbølsgade 50, 3., DK-1721 Copenhagen V (DK). VAN DER POEL, Mike; Rævehakkevej 35B, DK-2610 Rødovre (DK). KJÆR, Rasmus; Nørre Søgade 21, 1., DK-1370 Copenhagen K (DK). VINTHER, Michael; Tom Christens Vej 34, 4tv, DK-2300 Copenhagen S (DK). HOLLENBECK, Karl-Josef; Ribegade 12, 3th, DK-2100 Copenhagen Ø (DK).
- (74) **Agent:** MÜNZER, Marc; Guardian IP Consulting I/S, Diplomvej, Building 381, DK-2800 Kgs. Lyngby (DK).

(81) **Designated States** (unless otherwise indicated, for every kind of national protection available): AE, AG, AL, AM, AO, AT, AU, AZ, BA, BB, BG, BH, BN, BR, BW, BY, BZ, CA, CH, CL, CN, CO, CR, CU, CZ, DE, DK, DM, DO, DZ, EC, EE, EG, ES, FI, GB, GD, GE, GH, GM, GT, HN, HR, HU, ID, IL, IN, IR, IS, JP, KE, KG, KN, KP, KR, KZ, LA, LC, LK, LR, LS, LT, LU, LY, MA, MD, ME, MG, MK, MN, MW, MX, MY, MZ, NA, NG, NI, NO, NZ, OM, PA, PE, PG, PH, PL, PT, QA, RO, RS, RU, RW, SA, SC, SD, SE, SG, SK, SL, SM, ST, SV, SY, TH, TJ, TM, TN, TR, TT, TZ, UA, UG, US, UZ, VC, VN, ZA, ZM, ZW.

(84) **Designated States** (unless otherwise indicated, for every kind of regional protection available): ARIPO (BW, GH, GM, KE, LR, LS, MW, MZ, NA, RW, SD, SL, SZ, TZ, UG, ZM, ZW), Eurasian (AM, AZ, BY, KG, KZ, RU, TJ, TM), European (AL, AT, BE, BG, CH, CY, CZ, DE, DK, EE, ES, FI, FR, GB, GR, HR, HU, IE, IS, IT, LT, LU, LV, MC, MK, MT, NL, NO, PL, PT, RO, RS, SE, SI, SK, SM, TR), OAPI (BF, BJ, CF, CG, CI, CM, GA, GN, GQ, GW, KM, ML, MR, NE, SN, TD, TG).

Published:

- with international search report (Art. 21(3))
- before the expiration of the time limit for amending the claims and to be republished in the event of receipt of amendments (Rule 48.2(h))

(54) **Title:** FOCUS SCANNING APPARATUS RECORDING COLOR

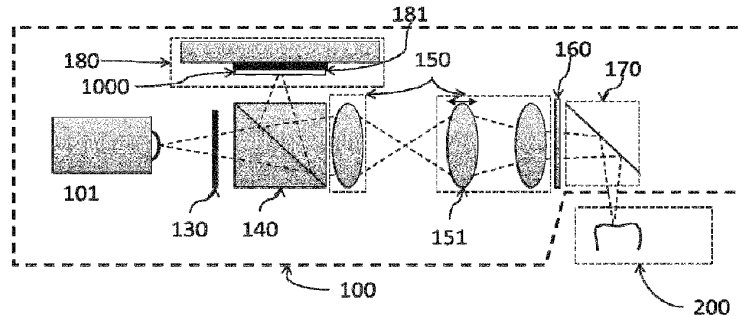

Fig. 1

(57) **Abstract:** Disclosed are a scanner system and a method for recording surface geometry and surface color of an object where both surface geometry information and surface color information for a block of said image sensor pixels at least partly from one 2D image recorded by said color image sensor.

WO 2014/125037 A1

Focus scanning apparatus recording color

Field of the application

- 5 The application relates to three dimensional (3D) scanning of the surface geometry and surface color of objects. A particular application is within dentistry, particularly for intraoral scanning.

Background

10

3D scanners are widely known from the art, and so are intraoral dental 3D scanners (e.g., Sirona Cerec, Cadent Itero, 3Shape TRIOS).

The ability to record surface color is useful in many applications. For example in
15 dentistry, the user can differentiate types of tissue or detect existing restorations. For example in materials inspection, the user can detect surface abnormalities such as crystallization defects or discoloring. None of the above is generally possible from surface geometry information alone.

20 WO2010145669 mentions the possibility of recording color. In particular, several sequential images, each taken for an illumination in a different color - typically blue, green, and red - are combined to form a synthetic color image. This approach hence requires means to change light source color, such as color filters. Furthermore, in handheld use, the scanner will move relative to the scanned object
25 during the illumination sequence, reducing the quality of the synthetic color image.

Also US7698068 and US8102538 (Cadent Inc.) describe an intraoral scanner that records both geometry data and texture data with one or more image sensor(s). However, there is a slight delay between the color and the geometry recording,
30 respectively. US7698068 requires sequential illumination in different colors to form a synthetic image, while US8102538 mentions white light as a possibility, however from a second illumination source or recorded by a second image sensor, the first set being used for recording the geometry.

WO2012083967 discloses a scanner for recording geometry data and texture data with two separate cameras. While the first camera has a relatively shallow depth of field as to provide focus scanning based on multiple images, the second camera has a relatively large depth of field as to provide color texture information from a single image.

Color-recording scanning confocal microscopes are also known from the prior art (e.g., Keyence VK9700; see also JP2004029373). A white light illumination system along with a color image sensor is used for recording 2D texture, while a laser beam forms a dot that is scanned, i.e., moved over the surface and recorded by a photomultiplier, providing the geometry data from many depth measurements, one for each position of the dot. The principle of a moving dot requires the measured object not to move relative to the microscope during measurement, and hence is not suitable for handheld use.

15

Summary

One aspect of this application is to provide a scanner system and a method for recording surface geometry and surface color of an object, and where surface geometry and surface color are derived from the same captured 2D images.

20

One aspect of this application is to provide a scanner system for recording surface geometry and surface color of an object, and wherein all 2D images are captured using the same color image sensor.

25

One aspect of this application is to provide a scanner system and a method for recording surface geometry and surface color of an object, in which the information relating to the surface geometry and to the surface color are acquired simultaneously such that an alignment of data relating to the recorded surface geometry and data relating to the recorded surface color is not required in order to generate a digital 3D representation of the object expressing both color and geometry of the object.

30

Disclosed is a scanner system for recording surface geometry and surface color of an object, the scanner system comprising:

- a multichromatic light source configured for providing a multichromatic probe light for illumination of the object,
- 5 - a color image sensor comprising an array of image sensor pixels for capturing one or more 2D images of light received from said object, and
- a data processing system configured for deriving both surface geometry information and surface color information for a block of said image sensor pixels at least partly from one 2D image recorded by said color image sensor.

10

Disclosed is a method of recording surface geometry and surface color of an object, the method comprising:

- obtaining a scanner system comprising a multichromatic light source and a color image sensor comprising an array of image sensor pixels;
- 15 - illuminating the surface of said object with multichromatic probe light from said multichromatic light source;
- capturing a series of 2D images of said object using said color image sensor; and
- 20 - deriving both surface geometry information and surface color information for a block of said image sensor pixels at least partly from one captured 2D image.

In the context of the present application, the phrase "surface color" may refer to the apparent color of an object surface and thus in some cases, such as for semi-transparent or semi-translucent objects such as teeth, be caused by light from the object surface and/or the material below the object surface, such as material immediately below the object surface.

In the context of the present application, the phrase "derived at least partly from one 2D image" refers to the situation where the surface geometry information for a

30

given block of image sensor pixels at least in part is derived from one 2D image and where the corresponding surface color information at least in part is derived from the same 2D image. The phase also covers cases where the surface geometry information for a given block of image sensor pixels at least in part is derived from a plurality of 2D images of a series of captured 2D images and where the corresponding surface color information at least in part is derived from the same 2D images of that series of captured 2D images.

An advantage of deriving both surface geometry information and surface color information for a block of said image sensor pixels at least partly from one 2D image is that a scanner system having only one image sensor can be realized.

It is an advantage that the surface geometry information and the surface color information are derived at least partly from one 2D image, since this inherently provides that the two types of information are acquired simultaneously. There is hence no requirement for an exact timing of the operation of two color image sensors, which may be the case when one image sensor is used for the geometry recording and another for color recording. Equally there is no need for an elaborate calculation accounting for significant differences in the timing of capturing of 2D images from which the surface geometry information is derived and the timing of the capturing of 2D images from which the surface color information is derived.

The present application discloses a significant improvement over the state of the art in that only a single image sensor and a single multichromatic light source is required, and that surface color and surface geometry for at least a part of the object can be derived from the same 2D image or 2D images, which also means that alignment of color and surface geometry is inherently perfect. In the scanner system according to the present application, there is no need for taking into account or compensating for relative motion of the object and scanner system between obtaining surface geometry and surface color. Since the surface geometry and the surface color are obtained at precisely the same time, the scanner system automatically maintains its spatial disposition with respect to the object surface while obtaining the surface geometry and the surface color. This

makes the scanner system of the present application suitable for handheld use, for example as an intraoral scanner, or for scanning moving objects.

In some embodiments, the data processing system is configured for deriving surface geometry information and surface color information for said block of image sensor pixels from a series of 2D images, such as from a plurality of the 2D images in a series of captured 2D images. I.e. the data processing system is capable of analyzing a plurality of the 2D images in a series of captured 2D images in order to derive the surface geometry information for a block of image sensor pixels and to also derive surface color information from at least one of the 2D images from which the surface geometry information is derived.

In some embodiments, the data processing system is configured for deriving surface color information from a plurality of 2D images of a series of captured 2D images and for deriving surface geometry information from at least one of the 2D images from which the surface color information is derived.

In some embodiments, the data processing system is configured for deriving surface geometry information from a plurality of 2D images of a series of captured 2D images and for deriving surface color information from at least one of the 2D images from which the surface geometry information is derived.

In some embodiments, the set of 2D images from which surface color information is derived from is identical to the set of 2D images from which surface geometry information is derived from.

In some embodiments, the data processing system is configured for generating a sub-scan of a part of the object surface based on surface geometry information and surface color information derived from a plurality of blocks of image sensor pixels. The sub-scan expresses at least the geometry of the part of the object and typically one sub-scan is derived from one stack of captured 2D images.

In some embodiments, all 2D images of a captured series of images are analyzed to derive the surface geometry information for each block of image sensor pixels on the color image sensor.

For a given block of image sensor pixels the corresponding portions of the captured 2D images in the stack may be analyzed to derive the surface geometry information and surface color information for that block.

In some embodiments, the surface geometry information relates to where the object surface is located relative to the scanner system coordinate system for that particular block of image sensor pixels.

One advantage of the scanner system and the method of the current application is that the informations used for generating the sub-scan expressing both geometry and color of the object (as seen from one view) are obtained concurrently.

Sub-scans can be generated for a number of different views of the object such that they together cover the part of the surface.

In some embodiments, the data processing system is configured for combining a number of sub-scans to generate a digital 3D representation of the object. The digital 3D representation of the object then preferably expresses both the recorded geometry and color of the object.

The digital 3D representation of the object can be in the form of a data file. When the object is a patient's set of teeth the digital 3D representation of this set of teeth can e.g. be used for CAD/CAM manufacture of a physical model of the patient's set teeth.

The surface geometry and the surface color are both determined from light recorded by the color image sensor.

In some embodiments, the light received from the object originates from the multichromatic light source, i.e. it is probe light reflected or scattered from the surface of the object.

In some embodiments, the light received from the object comprises fluorescence excited by the probe light from the multichromatic light source, i.e. fluorescence emitted by fluorescent materials in the object surface.

5

In some embodiments, a second light source is used for the excitation of fluorescence while the multichromatic light source provides the light for obtaining the geometry and color of the object.

10 The scanner system preferably comprises an optical system configured for guiding light emitted by the multichromatic light source towards the object to be scanned and for guiding light received from the object to the color image sensor such that the 2D images of said object can be captured by said color image sensor.

15 In some embodiments, the scanner system comprises a first optical system, such as an arrangement of lenses, for transmitting the probe light from the multichromatic light source towards an object and a second optical system for imaging light received from the object at the color image sensor.

20 In some embodiments, single optical system images the probe light onto the object and images the object, or at least a part of the object, onto the color image sensor, preferably along the same optical axis, however in opposite directions along optical axis. The scanner may comprise at least one beam splitter located in the optical path, where the beam splitter is arranged such that it directs the probe
25 light from the multichromatic light source towards the object while it directs light received from the object towards the color image sensor.

Several scanning principles are suitable, such as triangulation and focus scanning.

30 In some embodiments, the scanner system is a focus scanner system operating by translating a focus plane along an optical axis of the scanner system and capturing the 2D images at different focus plane positions such that each series of captured 2D images forms a stack of 2D images. The focus plane position is

preferably shifted along an optical axis of the scanner system, such that 2D images captured at a number of focus plane positions along the optical axis forms said stack of 2D images for a given view of the object, i.e. for a given arrangement of the scanner system relative to the object. After changing the arrangement of the scanner system relative to the object a new stack of 2D images for that view can be captured. The focus plane position may be varied by means of at least one focus element, e.g., a moving focus lens.

In some focus scanner embodiments, the scanner system comprises a pattern generating element configured for incorporating a spatial pattern in said probe light.

In some embodiments, the pattern generating element is configured to provide that the probe light projected by scanner system onto the object comprises a pattern consisting of dark sections and sections with light having the a wavelength distribution according to the wavelength distribution of the multichromatic light source.

In some embodiments, the multichromatic light source comprises a broadband light source, such as a white light source

In some embodiments, the pixels of the color image sensor and the pattern generating element are configured to provide that each pixel corresponds to a single bright or dark region of the spatial pattern incorporated in said probe light.

For a focus scanner system the surface geometry information for a given block of image sensor pixels is derived by identifying at which distance from the scanner system the object surface is in focus for that block of image sensor pixels.

In some embodiments, deriving the surface geometry information and surface color information comprises calculating for several 2D images, such as for several 2D images in a captured stack of 2D images, a correlation measure between the portion of the 2D image captured by said block of image sensor pixels and a

weight function. Here the weight function is preferably determined based on information of the configuration of the spatial pattern. The correlation measure may be calculated for each 2D image of the stack.

- 5 The scanner system may comprise means for evaluating a correlation measure at each focus plane position between at least one image pixel and a weight function, where the weight function is determined based on information of the configuration of the spatial pattern.
- 10 In some embodiments, deriving the surface geometry information and the surface color information for a block of image sensor pixels comprises identifying the position along the optical axis at which the corresponding correlation measure has a maximum value. The position along the optical axis at which the corresponding correlation measure has a maximum value may coincide with the position where a
- 15 2D image has been captured but it may even more likely be in between two neighboring 2D images of the stack of 2D images.

Determining the surface geometry information may then relate to calculating a correlation measure of the spatially structured light signal provided by the pattern with the variation of the pattern itself (which we term reference) for every location

20 of the focus plane and finding the location of an extremum of this stack of 2D images. In some embodiments, the pattern is static. Such a static pattern can for example be realized as a chrome-on-glass pattern.

One way to define the correlation measure mathematically with a discrete set of

25 measurements is as a dot product computed from a signal vector, $\mathbf{I} = (I_1, \dots, I_n)$, with $n > 1$ elements representing sensor signals and a reference vector, $\mathbf{f} = (f_1, \dots, f_n)$, of reference weights. The correlation measure A is then given by

$$A = \mathbf{f} \cdot \mathbf{I} = \sum_{i=1}^n f_i I_i$$

The indices on the elements in the signal vector represent sensor signals that are recorded at different pixels, typically in a block of pixels. The reference vector f can be obtained in a calibration step.

By using knowledge of the optical system used in the scanner, it is possible to transform the location of an extremum of the correlation measure, i.e., the focus plane into depth data information, on a pixel block basis. All pixel blocks combined thus provide an array of depth data. In other words, depth is along an optical path that is known from the optical design and/or found from calibration, and each block of pixels on the image sensor represents the end point of an optical path. Therefore, depth along an optical path, for a bundle of paths, yields a surface geometry within the field of view of the scanner, i.e. a sub-scan for the present view.

It can be advantageous to smooth and interpolate the series of correlation measure values, such as to obtain a more robust and accurate determination of the location of the maximum.

In some embodiments, the generating a sub-scan comprises determining a correlation measure function describing the variation of the correlation measure along the optical axis for each block of image sensor pixels and identifying for the position along the optical axis at which the correlation measure functions have their maximum value for the block.

In some embodiments, the maximum correlation measure value is the highest calculated correlation measure value for the block of image sensor pixels and/or the highest maximum value of the correlation measure function for the block of image sensor pixels.

For example, a polynomial can be fitted to the values of A for a pixel block over several images on both sides of the recorded maximum, and a location of a deducted maximum can be found from the maximum of the fitted polynomial, which can be in between two images. The deducted maximum is subsequently

used as depth data information when deriving the surface geometry from the present view, i.e. when deriving a sub-scan for the view.

5 In some embodiments, the data processing system is configured for determining a color for a point on a generated sub-scan based on the surface color information of the 2D image of the series in which the correlation measure has its maximum value for the corresponding block of image sensor pixels. The color may e.g. be read as the RGB values for pixels in said block of image sensor pixels.

10 In some embodiments, the data processing system is configured for deriving the color for a point on a generated sub-scan based on the surface color informations of the 2D images in the series in which the correlation measure has its maximum value for the corresponding block of image sensor pixels and on at least one additional 2D image, such as a neighboring 2D image from the series of captured
15 2D images. The surface color information is still derived from at least one of the 2D images from which the surface geometry information is derived.

In some embodiments, the data processing system is configured for interpolating surface color information of at least two 2D images in a series when determining
20 the sub-scan color, such as an interpolation of surface color information of neighboring 2D images in a series.

In some embodiments, the data processing system is configured for computing a smoothed color for a number of points of the sub-scan, where the computing
25 comprises an averaging of sub-scan colors of different points, such as a weighted averaging of the colors of the surrounding points on the sub-scan.

Surface color information for a block of image sensor pixels is at least partially derived from the same image from which surface geometry information is derived.
30 In case the location of the maximum of A is represented by a 2D image, then also color is derived from that same image. In case the location of the maximum of A is found by interpolation to be between two images, then at least one of those two

images should be used to derive color, or both images using interpolation for color also. It is also possible to average color data from more than two images used in the determination of the location of the maximum of the correlation measure, or to average color from a subset or superset of multiple images used to derive surface geometry. In any case, some image sensor pixels readings are used to derive both
5 surface color and surface geometry for at least a part of the scanned object.

Typically, there are three color filters, so the overall color is composed of three contributions, such as red, green, and blue, or cyan, magenta, and yellow. Note that color filters typically allow a range of wavelengths to pass, and there is
10 typically cross-talk between filters, such that, for example, some green light will contribute to the intensity measured in pixels with red filters.

For an image sensor with a color filter array, a color component c_j within a pixel block can be obtained as

$$c_j = \sum_{i=1}^n g_{j,i} I_i$$

where $g_{j,i} = 1$ if pixel i has a filter for color c_j , 0 otherwise. For an RGB filter array
15 like in a Bayer pattern, j is one of red, green, or blue. Further weighting of the individual color components, i.e., color calibration, may be required to obtain natural color data, typically as compensation for varying filter efficiency, illumination source efficiency, and different fraction of color components in the filter pattern. The calibration may also depend on focus plane location and/or position
20 within the field of view, as the mixing of the light source component colors may vary with those factors.

In some embodiments, surface color information is obtained for every pixel in a pixel block. In color image sensors with a color filter array or with other means to separate colors such as diffractive means, depending on the color measured with
25 a particular pixel, an intensity value for that color is obtained. In other words, in this case a particular pixel has a color value only for one color. Recently developed color image sensors allow measurement of several colors in the same pixel, at different depths in the substrate, so in that case, a particular pixel can yield

intensity values for several colors. In summary, it is possible to obtain a resolution of the surface color data that is inherently higher than that of the surface geometry information.

In the embodiments where the resolution of the derived color is higher than the resolution of the surface geometry for the generated digital 3D representation of the object, a pattern will be visible when at least approximately in focus, which preferably is the case when color is derived. The image can be filtered such as to visually remove the pattern, however at a loss of resolution. In fact, it can be advantageous to be able to see the pattern for the user. For example in intraoral scanning, it may be important to detect the position of a margin line, the rim or edge of a preparation. The image of the pattern overlaid on the geometry of this edge is sharper on a side that is seen approximately perpendicular, and more blurred on the side that is seen at an acute angle. Thus, a user, who in this example typically is a dentist or dental technician, can use the difference in sharpness to more precisely locate the position of the margin line than may be possible from examining the surface geometry alone.

High spatial contrast of an in-focus pattern image on the object is desirable to obtain a good signal to noise ratio of the correlation measure on the color image sensor. Improved spatial contrast can be achieved by preferential imaging of the specular surface reflection from the object on the color image sensor. Thus, some embodiments comprise means for preferential/selective imaging of specularly reflected light. This may be provided if the scanner further comprises means for polarizing the probe light, for example by means of at least one polarizing beam splitter.

In some embodiments, the polarizing optics is coated such as to optimize preservation of the circular polarization of a part of the spectrum of the multichromatic light source that is used for recording the surface geometry.

The scanner system may further comprise means for changing the polarization state of the probe light and/or the light received from the object. This can be provided by means of a retardation plate, preferably located in the optical path. In some embodiments, the retardation plate is a quarter wave retardation plate.

Especially for intraoral applications where the scanned object e.g. is the patient's set or teeth, the scanner can have an elongated tip, with means for directing the probe light and/or imaging an object. This may be provided by means of at least one folding element. The folding element could be a light reflecting element such as a mirror or a prism. The probe light then emerges from the scanner system along an optical axis at least partly defined by the folding element.

For a more in-depth description of the focus scanning technology, see WO2010145669.

In some embodiments, the data processing system is configured for determining the color of a least one point of the generated digital 3D representation of the object, such that the digital 3D representation expresses both geometry and color profile of the object. Color may be determined for several points of the generated digital 3D representation such that the color profile of the scanned part of the object is expressed by the digital 3D representation.

In some embodiments determining the object color comprises computing a weighted average of color values derived for corresponding points in overlapping sub-scans at that point of the object surface. This weighted average can then be used as the color of the point in the digital 3D representation of the object.

In some embodiments the data processing system is configured for detecting saturated pixels in the captured 2D images and for mitigating or removing the error in the derived surface color information or the sub-scan color caused by the pixel saturation.

In some embodiments the error caused by the saturated pixel is mitigated or removed by assigning a low weight to the surface color information of the saturated pixel in the computing of the smoothed color of a sub-scan and/or by assigning a low weight to the color of a sub-scan computed based on the saturated pixel.

In some embodiments, the data processing system is configured for comparing the derived surface color information of sections of the captured 2D images and/or of the generated sub-scans of the object with predetermined color ranges for teeth and for oral tissue, and for suppressing the red component of the derived surface color information or sub-scan color for sections where the color is not in one of the two predetermined color ranges.

The scanner system disclosed here comprises a multichromatic light source, for example a white light source, for example a multi-die LED.

Light received from the scanned object, such as probe light returned from the object surface or fluorescence generated by the probe light by exciting fluorescent parts of the object, is recorded by the color image sensor. In some embodiments, the color image sensor comprises a color filter array such that every pixel in the color image sensor is a color-specific filter. The color filters are preferably arranged in a regular pattern, for example where the color filters are arranged according to a Bayer color filter pattern. The image data thus obtained are used to derive both surface geometry and surface color for each block of pixels. For a focus scanner utilizing a correlation measure, the surface geometry may be found from an extremum of the correlation measure as described above.

In some embodiments, the surface geometry is derived from light in a first part of the spectrum of the probe light provided by the multichromatic light source.

Preferably, the color filters are aligned with the image sensor pixels, preferably such that each pixel has a color filter for a particular color only.

In some embodiments, the color filter array is such that its proportion of pixels with color filters that match the first part of the spectrum is larger than 50%.

In some embodiments, the surface geometry information is derived from light in a selected wavelength range of the spectrum provided by the multichromatic light source. The light in the other wavelength ranges is hence not used to derive the surface geometry information. This provides the advantage that chromatic dispersion of optical elements in the optical system of the scanner system does not influence the scanning of the object.

It can be preferable to compute the surface geometry only from pixels with one or two types of color filters. A single color requires no achromatic optics and is thus provides for a scanner that is easier and cheaper to build. Furthermore, folding elements can generally not preserve the polarization state for all colors equally well. When only some color(s) is/are used to compute surface geometry, the reference vector f will contain zeros for the pixels with filters for the other color(s). Accordingly, the total signal strength is generally reduced, but for large enough blocks of pixels, it is generally still sufficient. Preferentially, the pixel color filters are adapted for little cross-talk from one color to the other(s). Note that even in the embodiments computing geometry from only a subset of pixels, color is preferably still computed from all pixels.

In some embodiments, the color image sensor comprises a color filter array comprising at least three types of colors filters, each allowing light in a known wavelength range, W_1 , W_2 , and W_3 respectively, to propagate through the color filter.

In some embodiments, the color filter array is such that its proportion of pixels with color filters that match the selected wavelength range of the spectrum is larger than 50%, such a wherein the proportion equals 32/36, 60/64 or 96/100.

In some embodiments, the selected wavelength range matches the W_2 wavelength range.

In some embodiments, the color filter array comprises a plurality of cells of 6x6 color filters, where the color filters in positions (2,2) and (5,5) of each cell are of the W_1 type, the color filters in positions (2,5) and (5,2) are of the W_3 type. Here a W_1 type of filter is a color filter that allows light in the known wavelength range W_1 to propagate through the color filter, and similar for W_2 and W_3 type of filters. In some embodiments, the remaining 32 color filters in the 6x6 cell are of the W_2 type.

In a RGB color system, W1 may correspond to red light, W2 to green light, and W3 to blue light.

- 5 In some embodiments, the scanner is configured to derive the surface color with a higher resolution than the surface geometry.

In some embodiments, the higher surface color resolution is achieved by demosaicing, where color values for pixel blocks may be demosaiced to achieve an apparently higher resolution of the color image than is present in the surface
10 geometry. The demosaicing may operate on pixel blocks or individual pixels.

In case a multi-die LED or another illumination source comprising physically or optically separated light emitters is used, it is preferable to aim at a Köhler type illumination in the scanner, i.e. the illumination source is defocused at the object plane in order to achieve uniform illumination and good color mixing for the entire
15 field of view. In case color mixing is not perfect and varies with focal plane location, color calibration of the scanner will be advantageous.

In some embodiments, the pattern generating element is configured to provide that the spatial pattern comprises alternating dark and bright regions arranged in a checkerboard pattern. The probe light provided by the scanner system then
20 comprises a pattern consisting of dark sections and sections with light having the same wavelength distribution as the multichromatic light source.

In order to obtain a digital 3D representation expressing both surface geometry and color representation of an object, i.e. a colored digital 3D representation of said part of the object surface, typically several sub-scans, i.e. partial
25 representations of the object, have to be combined, where each sub-scans presents one view of the object. A sub-scan expressing a view from a given relative position preferably records the geometry and color of the object surface as seen from that relative position.

For a focus scanner, a view corresponds to one pass of the focusing element(s),
30 i.e. for a focus scanner each sub-scan is the surface geometry and color derived

from the stack of 2D images recorded during the pass of the focus plane position between its extremum positions.

The surface geometry found for various views can be combined by algorithms for stitching and registration as widely known in the literature, or from known view
5 positions and orientations, for example when the scanner is mounted on axes with encoders. Color can be interpolated and averaged by methods such as texture weaving, or by simply averaging corresponding color components in multiple views of the same location on the surface. Here, it can be advantageous to account for differences in apparent color due to different angles of incidence and reflection,
10 which is possible because the surface geometry is also known. Texture weaving is described by e.g. Callieri M, Cignoni P, Scopigno R. "Reconstructing textured meshes from multiple range rgb maps". VMV 2002, Erlangen, Nov 20-22, 2002.

In some embodiments, the scanner and/or the scanner system is configured for generating a sub-scan of the object surface based on the obtained surface color
15 and surface geometry.

In some embodiments, the scanner and/or the scanner system is configured for combining sub-scans of the object surface obtained from different relative positions to generate a digital 3D representation expressing the surface geometry and color of at least part of the object.

20 In some embodiments, the combination of sub-scans of the object to obtain the digital 3D representation expressing surface geometry and color comprises computing the color in each surface point as a weighted average of corresponding points in all overlapping sub-scans at that surface point. The weight of each sub-scan in the sum may be determined by several factors, such as the presence of
25 saturated pixel values or the orientation of the object surface with respect to the scanner when the sub-scan is recorded.

Such a weighted average is advantageous in cases where some scanner positions and orientations relative to the object will give a better estimate of the actual color than other positions and orientations. If the illumination of the object surface is
30 uneven this can to some degree also be compensated for by weighting the best illuminated parts higher.

In some embodiments, the data processing system of the scanner system comprises an image processor configured for performing a post-processing of the surface geometry, the surface color readings, or the derived sub-scan or the digital 3D representation of the object. The scanner system may be configured for performing the combination of the sub-scans using e.g. computer implemented algorithms executed by the image processor.

The scanner system may be configured for performing the combination of the sub-scans using e.g. computer implemented algorithms executed by the data processing system as part of the post-processing of the surface geometry, surface color, sub-scan and/or the digital 3D representation, i.e. the post-processing comprises computing the color in each surface point as a weighted average of corresponding points in all overlapping sub-scans at that surface point.

Saturated pixel values should preferably have a low weight to reduce the effect of highlights on the recording of the surface color. The color for a given part of the surface should preferably be determined primarily from 2D images where the color can be determined precisely which is not the case when the pixel values are saturated.

In some embodiments, the scanner and/or scanner system is configured for detecting saturated pixels in the captured 2D images and for mitigating or removing the error in the obtained color caused by the pixel saturation. The error caused by the saturated pixel may be mitigated or removed by assigning a low weight to the saturated pixel in the weighted average.

Specularly reflected light has the color of the light source rather than the color of the object surface. If the object surface is not a pure white reflector then specular reflections can hence be identified as the areas where the pixel color closely matches the light source color. When obtaining the surface color it is therefore advantageous to assign a low weight to pixels or pixel groups whose color values closely match the color of the multichromatic light source in order to compensate for such specular reflections.

Specular reflections may also be a problem when intra orally scanning a patient's set of teeth since teeth rarely are completely white. It may hence be advantageous

to assume that for pixels where the readings from the color images sensor indicate that the surface of the object is a pure white reflector, the light recorded by this pixel group is caused by a specular reflection from the teeth or the soft tissue in the oral cavity and accordingly assign a low weight to these pixels to compensate
5 for the specular reflections.

In some embodiments, the compensation for specular reflections from the object surface is based on information derived from a calibration of the scanner in which a calibration object e.g. in the form of a pure white reflector is scanned. The color image sensor readings then depend on the spectrum of the multichromatic light
10 source and on the wavelength dependence of the scanner's optical system caused by e.g. a wavelength dependent reflectance of mirrors in the optical system. If the optical system guides light equally well for all wavelengths of the multichromatic light source, the color image sensor will record the color (also referred to as the spectrum) of the multichromatic light source when the pure white reflector is
15 scanned.

In some embodiments, compensating for the specular reflections from the surface is based on information derived from a calculation based on the wavelength dependence of the scanner's optical system, the spectrum of the multichromatic light source and a wavelength dependent sensitivity of the color image sensor. In
20 some embodiments, the scanner comprises means for optically suppressing specularly reflected light to achieve better color measurement. This may be provided if the scanner further comprises means for polarizing the probe light, for example by means of at least one polarizing beam splitter.

When scanning inside an oral cavity there may be red ambient light caused by
25 probe light illumination of surrounding tissue, such as the gingiva, palette, tongue or buccal tissue. In some embodiments, the scanner and/or scanner system is hence configured for suppressing the red component in the recorded 2D images.

In some embodiments, the scanner and/or scanner system is configured for comparing the color of sections of the captured 2D images and/or of the sub-scans
30 of the object with predetermined color ranges for teeth and for oral tissue, respectively, and for suppressing the red component of the recorded color for

sections where the color is not in either one of the two predetermined color ranges. The teeth may e.g. be assumed to be primarily white with one ratio between the intensity of the different components of the recorded image, e.g. with one ratio between the intensity of the red component and the intensity of the blue and/or green components in a RGB configuration, while oral tissue is primarily reddish with another ratio between the intensity of the components. When a color recorded for a region of the oral cavity shows a ratio which differs from both the predetermined ratio for teeth and the predetermined ratio for tissue, this region is identified as a tooth region illuminated by red ambient light and the red component of the recorded image is suppressed relative to the other components, either by reducing the recorded intensity of the red signal or by increasing the recorded intensities of the other components in the image.

In some embodiments, the color of points with a surface normal directly towards the scanner are weighted higher than the color of points where the surface normal is not directed towards the scanner. This has the advantage that points with a surface normal directly towards the scanner will to a higher degree be illuminated by the white light from the scanner and not by the ambient light.

In some embodiments, the color of points with a surface normal directly towards the scanner are weighted lower if associated with specular reflections.

In some embodiments the scanner is configured for simultaneously compensating for different effects, such as compensating for saturated pixels and/or for specular reflections and/or for orientation of the surface normal. This may be done by generally raising the weight for a selection of pixels or pixel groups of a 2D image and by reducing the weight for a fraction of the pixels or pixel groups of said selection.

In some embodiments, the method comprises a processing of recorded 2D images, a sub-scan or the generated 3D representations of the part of the object, where said processing comprises

- compensating for pixel saturation by omitting or reducing the weight of saturated pixels when deriving the surface color, and/or

- compensating for specular reflections when deriving the surface color by omitting or reducing the weight of pixels whose color values closely matches the light source color, and/or
- compensating for red ambient light by comparing surface color information of the 2D images with predetermined color ranges, and suppressing the red component of the recorded color if this is not within a predetermined color range.

Disclosed is a method of using the disclosed scanner system to display color texture on the generated digital 3D representation of the object. It is advantageous to display the color data as a texture on the digital 3D representation, for example on a computer screen. The combination of color and geometry is a more powerful conveyor of information than either type of data alone. For example, dentists can more easily differentiate between different types of tissue. In the rendering of the surface geometry, appropriate shading can help convey the surface geometry on the texture, for example with artificial shadows revealing sharp edges better than texture alone could do.

When the multichromatic light source is a multi-die LED or similar, the scanner system can also be used to detect fluorescence. Disclosed is a method of using the disclosed scanner system to display fluorescence on surface geometry.

In some embodiments, the scanner is configured for exciting fluorescence on said object by illuminating it with only a subset of the LED dies in the multi-die LED, and where said fluorescence is recorded by only or preferentially reading out only those pixels in the color image sensor that have color filters at least approximately matching the color of the fluoresced light, i.e. measuring intensity only in pixels of the image sensors that have filters for longer-wavelength light. In other words, the scanner is capable of selectively activating only a subset of the LED dies in the multi-die LED and of only recording or preferentially reading out only those pixels in the color image sensor that have color filters at a higher wavelength than that of the subset of the LED dies, such that light emitted from the subset of LED dies can excite fluorescent materials in the object and the scanner can record the

fluorescence emitted from these fluorescent materials. The subset of the dies preferably comprises one or more LED dies which emits light within the excitation spectrum of the fluorescent materials in the object, such as an ultraviolet, a blue, a green, a yellow or a red LED die. Such fluorescence measurement yields a 2D data array much like the 2D color image, however unlike the 2D image it cannot be taken concurrently with the surface geometry. For a slow-moving scanner, and/or with appropriate interpolation, the fluorescence image can still be overlaid the surface geometry. It is advantageous to display fluorescence on teeth because it can help detect caries and plaque.

10 In some embodiments, the data processing system comprises a microprocessor unit configured for extracting the surface geometry information from 2D images obtained by the color image sensor and for determining the surface color from the same images.

The data processing system may comprise units distributed in different parts of the scanner system. For a scanner system comprising a handheld part connected to a stationary unit, the data processing system may for example comprise one unit integrated in the handheld part and another unit integrated in the stationary unit. This can be advantageous when a data connection for transferring data from the handheld unit to the stationary unit has a bandwidth which cannot handle the data stream from the color image sensor. A preliminary data processing in the handheld unit can then reduce the amount of data which must be transferred via the data connection.

In some embodiments, the data processing system comprises a computer readable medium on which is stored computer implemented algorithms for performing said post-processing.

In some embodiments, a part of the data processing system is integrated in a cart or a personal computer.

Disclosed is a method of using the disclosed scanner system to average color and/or surface geometry from several views, where each view represents a substantially fixed relative orientation of scanner and object.

5 Disclosed is a method using the disclosed scanner system to combine color and/or surface geometry from several views, where each view represents a substantially fixed relative orientation of scanner and object, such as to achieve a more complete coverage of the object than would be possible in a single view.

10 Disclosed is a scanner for obtaining surface geometry and surface color of an object, the scanner comprising:

- a multichromatic light source configured for providing a probe light, and
- a color image sensor comprising an array of image sensor pixels for recording one or more 2D images of light received from said object,

15 where at least for a block of said image sensor pixels, both surface color and surface geometry of a part of the object are derived at least partly from one 2D image recorded by said color image sensor

Disclosed is a scanner system for recording surface geometry and surface color of an object, the scanner system comprising:

- 20
- a multichromatic light source configured for providing a multichromatic probe light, and
 - a color image sensor comprising an array of image sensor pixels for capturing one or more 2D images of light received from said object,

25 where at least for a block of said image sensor pixels, both surface color information and surface geometry information of a part of the object are derived at least partly from one 2D image captured by said color image sensor.

Disclosed is a scanner system for recording surface geometry and surface color of an object, the scanner system comprising:

- a multichromatic light source configured for providing a probe light,
- a color image sensor comprising an array of image sensor pixels, and
- 5 - an optical system configured for guiding light received from the object to the color image sensor such that 2D images of said object can be captured by said color image sensor;

wherein the scanner system is configured for capturing a number of said 2D images of a part of the object and for deriving both surface color information and surface geometry information of the part of the object from at least one of said captured 2D images at least for a block of said color image sensor pixels, such that the surface color information and the surface geometry information are obtained concurrently by the scanner.

15 Disclosed is a scanner system for recording surface geometry and surface color of an object, the scanner system comprising:

- a multichromatic light source configured for providing a probe light;
- a color image sensor comprising an array of image sensor pixels, where the image sensor is arranged to capture 2D images of light received from the object; and
- 20 - an image processor configured for deriving both surface color information and surface geometry information of at least a part of the object from at least one of said 2D images captured by the color image sensor.

25

Disclosed is a scanner system for recording surface geometry and surface color of an object, said scanner system comprising

- a scanner system according to any of the embodiments, where the scanner system is configured for deriving surface color and surface geometry of the object, and optionally for generating a sub-scan or a digital 3D representation of the part of the object; and
- 5 - a data processing unit configured for post-processing surface geometry and/or surface color readings from the color image sensor, or for post-processing the generated sub-scan or digital 3D representation.

Disclosed is a method of recording surface geometry and surface color of an
10 object, the method comprising:

- providing a scanner or scanner system according to any of the embodiments;
- illuminating the surface of said object with probe light from said multichromatic light source;
- 15 - recording one or more 2D images of said object using said color image sensor; and
- deriving both surface color and surface geometry of a part of the object from at least some of said recorded 2D images at least for a block of said image sensor pixels, such that the surface color and surface
20 geometry are obtained concurrently by the scanner.

Brief description of drawings

Fig. 1 shows a handheld embodiment of a scanner system.

25 Fig. 2 shows prior art pattern generating means and associated reference weights.

Fig. 3 shows a pattern generating means and associated reference weights.

Fig. 4 shows a color filter array.

Fig. 5 shows a flow chart of a method.

Fig. 6 illustrates how surface geometry information and surface geometry information can be derived

- 5 Fig. 1 shows a handheld part of a scanner system with components inside a housing 100. The scanner comprises a tip which can be entered into a cavity, a multichromatic light source in the form of a multi-die LED 101, pattern generating element 130 for incorporating a spatial pattern in the probe light, a beam splitter 140, color image sensor 180 including an image sensor 181, electronics and
- 10 potentially other elements, an optical system typically comprising at least one lens, and the image sensor. The light from the light source 101 travels back and forth through the optical system 150. During this passage the optical system images the pattern 130 onto the object being scanned 200 which here is a patient's set of teeth, and further images the object being scanned onto the image sensor 181.
- 15 The image sensor 181 has a color filter array 1000. Although drawn as a separate entity, the color filter array is typically integrated with the image sensor, with a single-color filter for every pixel.

The lens system includes a focusing element 151 which can be adjusted to shift the focal imaging plane of the pattern on the probed object 200. In the example

20 embodiment, a single lens element is shifted physically back and forth along the optical axis.

As a whole, the optical system provides an imaging of the pattern onto the object being probed and from the object being probed to the camera.

The device may include polarization optics 160. Polarization optics can be used to

25 selectively image specular reflections and block out undesired diffuse signal from sub-surface scattering inside the scanned object. The beam splitter 140 may also have polarization filtering properties. It can be advantageous for optical elements to be anti-reflection coated.

The device may include folding optics, a mirror 170, which directs the light out of the device in a direction different to the optical path of the lens system, e.g. in a direction perpendicular to the optical path of the lens system.

There may be additional optical elements in the scanner, for example one or more
5 condenser lens in front of the light source 101.

In the example embodiment, the LED 101 is a multi-die LED with two green, one red, and one blue die. Only the green portion of the light is used for obtaining the surface geometry. Accordingly, the mirror 170 is coated such as to optimize preservation of the circular polarization of the green light, and not that of the other
10 colors. Note that during scanning all dies within the LED are active, i.e., emitting light, so the scanner emits apparently white light onto the scanned object 200. The LED may emit light at the different colors with different intensities such that e.g. one color is more intense than the other colors. This may be desired in order to reduce cross-talk between the readings of the different color signals in the color
15 image sensor. In case that the intensity of e.g. the red and blue diodes in a RGB system is reduced, the apparently white light emitted by the light source will appear greenish-white.

The scanner system further comprises a data processing system configured for deriving both surface geometry information and surface color information for a
20 block of pixels of the color image sensor 180 at least partly from one 2D image recorded by said color image sensor 180. At least part of the data processing system may be arranged in the illustrated handheld part of the scanner system. A part may also be arranged in an additional part of the scanner system, such as a cart connected to the handheld part.

25

Figure 2 shows an section of a prior art pattern generating element 130 that is applied as a static pattern in a spatial correlation embodiment of WO2010145669, as imaged on a monochromatic image sensor 180. The pattern can be a chrome-on-glass pattern. The section shows only a portion of the pattern is shown, namely
30 one period. This period is represented by a pixel block of 6 by 6 image pixels, and 2 by 2 pattern fields. The fields drawn in gray in Fig. 2A are in actuality black

because the pattern mask is opaque for these fields; gray was only chosen for visibility and thus clarity of the Figure. Fig. 2B illustrates the reference weights f for computing the spatial correlation measure A for the pixel block, where $n = 6 \times 6 = 36$, such that

$$A = \sum_{i=1}^n f_i I_i$$

5 where I are the intensity values measured in the 36 pixels in the pixel block for a given image. Note that perfect alignment between image sensor pixels and pattern fields is not required, but gives the best signal for the surface geometry measurement.

Fig. 3 shows the extension of the principle in Fig. 2 to color scanning. The pattern is the same as in Fig. 2 and so is the image sensor geometry. However, the image sensor is a color image sensor with a Bayer color filter array. In Fig. 3A, pixels marked "B" have a blue color filter, while "G" indicates green and "R" red pixel filters, respectively. Fig. 3B shows the corresponding reference weights f . Note that only green pixels have a non-zero value. This is so because only the green fraction of the spectrum is used for recording the surface geometry information.

For the pattern/color filter combination of Fig. 3, a color component c_j within a pixel block can be obtained as

$$c_j = \sum_{i=1}^n g_{j,i} I_i$$

where $g_{j,i} = 1$ if pixel i has a filter for color c_j , 0 otherwise. For an RGB color filter array like in the Bayer pattern, j is one of red, green, or blue. Further weighting of the individual color components, i.e., color calibration, may be required to obtain natural color data, typically as compensation for varying filter efficiency, illumination source efficiency, and different fraction of color components in the filter pattern. The calibration may also depend on focus plane location and/or position within the field of view, as the mixing of the LED's component colors may vary with those factors.

Figure 4 shows an inventive color filter array with a higher fraction of green pixels than in the Bayer pattern. The color filter array comprises a plurality of cells of 6x6 color filters, with blue color filters in positions (2,2) and (5,5) of each cell, red color filters in positions (2,5) and (5,2), and green color filters in all remaining positions of the cell.

Assuming that only the green portion of the illumination is used to obtain the surface geometry information, the filter of Figure 4 will potentially provide a better quality of the obtained surface geometry than a Bayer pattern filter, at the expense of poorer color representation. The poorer color representation will however in many cases still be sufficient while the improved quality of the obtained surface geometry often is very advantageous.

Fig. 5 illustrates a flow chart 541 of a method of recording surface geometry and surface color of an object.

In step 542 a scanner system according to any of the previous claims is obtained.

In step 543 the object is illuminated with multichromatic probe light. In a focus scanning system utilizing a correlation measure or correlation measure function, a checkerboard pattern may be imposed on the probe light such that information relating to the pattern can be used for determining surface geometry information from captured 2D images.

In step 544 a series of 2D images of said object is captured using said color image sensor. The 2D images can be processed immediately or stored for later processing in a memory unit.

In step 545 both surface geometry information and surface color information are derived for a block of image sensor pixels at least partly from one captured 2D image. The information can e.g. be derived using the correlation measure approach as described herein. The derived informations are combined to generate

a sub-scan of the object in step 546, where the sub-scan comprises data expressing the geometry and color of the object as seen from one view.

In step 547 a digital 3D representation expressing both color and geometry of the object is generated by combining several sub-scans. This may be done using
5 known algorithms for sub-scan alignment such as algorithms for stitching and registration as widely known in the literature.

Fig. 6 illustrates how surface geometry information and surface geometry
information can be derived at least from one 2D image for a block of image sensor
10 pixels.

The correlation measure is determined for all active image sensor pixel groups on the color image sensor for every focus plane position, i.e. for every 2D image of the stack. Starting by analyzing the 2D images from one end of the stack, the correlation measures for all active image sensor pixel groups is determined and
15 the calculated values are stored. Progressing through the stack the correlation measures for each pixel group are determined and stored together with the previously stored values, i.e. the values for the previously analyzed 2D images.

A correlation measure function describing the variation of the correlation measure along the optical axis is then determined for each pixel group by smoothing and
20 interpolating the determined correlation measure values. For example, a polynomial can be fitted to the values of for a pixel block over several images on both sides of the recorded maximum, and a location of a deducted maximum can be found from the maximum of the fitted polynomial, which can be in between two images.

25 The surface color information for the pixel group is derived from one or more of the 2D images from which the position of the correlation measure maximum was determined i.e. surface geometry information and surface color information from a group of pixels of the color image sensor are derived from the same 2D images of the stack.

The surface color information can be derived from one 2D image. The maximum value of the correlation measure for each group of pixels is monitored along the analysis of the 2D images such that when a 2D image has been analyzed the values for the correlation measure for the different pixels groups can be compared with the currently highest value for the previously analyzed 2D images. If the correlation measure is a new maximum value for that pixel group at least the portion of the 2D image corresponding to this pixel group is saved. Next time a higher correlation value is found for that pixel group the portion of this 2D image is saved overwriting the previously stored image/sub-image. Thereby when all 2D images of the stack have been analyzed, the surface geometry information of the 2D images is translated into a series of correlation measure values for each pixel group where a maximum value is recorded for each block of image sensor pixels.

Fig. 6A illustrated a portion 661 of a stack of 2D images acquired using a focus scanning system, where each 2D image is acquired at a different focal plane position. In each 2D image 662 a portion 663 corresponding to a block of image sensor pixels are indicated. The block corresponding to a set of coordinates (x_i, y_i) . The focus scanning system is configured for determining a correlation measure for each block of image sensor pixels and for each 2D image in the stack. In Fig. 6B is illustrated the determined correlation measures 664 (here indicated by an "x") for the block 663. Based on the determined correlation measures 664 a correlation measure function 665 is calculated, here as a polynomial, and a maximum value for the correlation measure function is found a position z_i . The z-value for which the fitted polynomial has a maximum (z_i) is identified as a point of the object surface. The surface geometry information derived for this block can then be presented in the form of the coordinates (x_i, y_i, z_i) , and by combining the surface geometry information for several block of the images sensor, the a sub-scan expressing the geometry of part of the object can be created.

In Fig. 6C is illustrated a procedure for deriving the surface color geometry from two 2D images for each block of image sensor pixels. Two 2D images are stored using the procedure described above and their RGB values for the pixel block are determined. In Fig. 6C the R-values 666 are displayed. An averaged R-value 667 (as well as averaged G- and B-values) at the z_i position can then be determined by

interpolation and used as surface color information for this block. This surface color information is evidently derived from the same 2D image that the geometry information at least in part was derived from.

Claims

1. A scanner system for recording surface geometry and surface color of an object, the scanner system comprising:
 - 5 - a multichromatic light source configured for providing a multichromatic probe light for illumination of the object,
 - a color image sensor comprising an array of image sensor pixels for capturing one or more 2D images of light received from said object, and
 - 10 - a data processing system configured for deriving both surface geometry information and surface color information for a block of said image sensor pixels at least partly from one 2D image recorded by said color image sensor.
- 15 2. The scanner system according to claim 1, wherein the data processing system is configured for deriving surface geometry information and surface color information for said block of image sensor pixels from a series of 2D images.
- 20 3. The scanner system according to claim 1 or 2, wherein the data processing system is configured for generating a sub-scan of a part of the object surface based on surface geometry information and surface color information derived from a plurality of blocks of image sensor pixels.
- 25 4. The scanner system according to any of claims 1 to 3, wherein the data processing system is configured for combining a number of sub-scans to generate a digital 3D representation of the object.
- 30 5. The scanner system according to any of claims 2 to 5, where the scanner system is a focus scanner system operating by translating a focus plane along an optical axis of the scanner system and capturing the 2D images at different focus plane positions such that each series of captured 2D images forms a stack of 2D images.

6. The scanner system according to any of the preceding claims, where the scanner system comprises a pattern generating element configured for incorporating a spatial pattern in said probe light.
- 5 7. The scanner system according to any of the preceding claims, where deriving the surface geometry information and surface color information comprises calculating for several 2D images a correlation measure between the portion of the 2D image captured by said block of image sensor pixels and a weight function, where the weight function is determined based on
10 information of the configuration of the spatial pattern.
8. The scanner system according to the preceding claim, wherein deriving the surface geometry information and the surface color information for a block of image sensor pixels comprises identifying the position along the optical
15 axis at which the corresponding correlation measure has a maximum value.
9. The scanner system according to claim 7 or 8, wherein generating a sub-scan comprises determining a correlation measure function describing the variation of the correlation measure along the optical axis for each block of
20 image sensor pixels and identifying for the position along the optical axis at which the correlation measure functions have their maximum value for the block.
10. The scanner system according to the preceding claim, where the maximum
25 correlation measure value is the highest calculated correlation measure value for the block of image sensor pixels and/or the highest maximum value of the correlation measure function for the block of image sensor pixels
- 30 11. The scanner system according to any of the preceding claims, wherein the data processing system is configured for determining a sub-scan color for a point on a generated sub-scan based on the surface color information of the

2D image in the series in which the correlation measure has its maximum value for the corresponding block of image sensor pixels.

- 5 12. The scanner system according to the preceding claim, wherein the data processing system is configured for deriving the sub-scan color for a point on a generated sub-scan based on the surface color informations of the 2D images in the series in which the correlation measure has its maximum value for the corresponding block of image sensor pixels and on at least one additional 2D image, such as a neighboring 2D image from the series of captured 2D images..
- 10
13. The scanner system according to the preceding claim, where the data processing system is configured for interpolating surface color information of at least two 2D images in a series when determining the sub-scan color, such as an interpolation of surface color information of neighboring 2D images in a series.
- 15
14. The scanner system according to any of the preceding claims wherein the data processing system is configured for computing a smoothed sub-scan color for a number of points of the sub-scan, where the computing comprises an averaging of sub-scan colors of different points, such as a weighted averaging of the colors of the surrounding points on the sub-scan.
- 20
15. The scanner system according to any of the preceding claims, where the data processing system is configured for determining object color of a least one point of the generated digital 3D representation of the object, such that the digital 3D representation expresses both geometry and color profile of the object,..
- 25
16. The scanner system according to the previous claim, wherein determining the object color comprises computing a weighted average of sub-scan color values derived for corresponding points in overlapping sub-scans at that point of the object surface.
- 30

17. The scanner system according to any the previous claims, wherein the data processing system is configured for detecting saturated pixels in the captured 2D images and for mitigating or removing the error in the derived surface color information or the sub-scan color caused by the pixel saturation.
18. The scanner system according to the previous claim wherein the error caused by the saturated pixel is mitigated or removed by assigning a low weight to the surface color information of the saturated pixel in the computing of the smoothed sub-scan color and/or by assigning a low weight to the sub-scan color computed based on the saturated pixel.
19. The scanner system according to any any of the preceding claims, wherein the data processing system is configured for comparing the derived surface color information of sections of the captured 2D images and/or of the generated sub-scans of the object with predetermined color ranges for teeth and for oral tissue, and for suppressing the red component of the derived surface color information or sub-scan color for sections where the color is not in one of the two predetermined color ranges.
20. The scanner system according to any of the preceding claims where the color image sensor comprises a color filter array comprising at least three types of colors filters, each allowing light in a known wavelength range, W1, W2, and W3 respectively, to propagate through the color filter.
21. The scanner system according to any of the preceding claims where the surface geometry information is derived from light in a selected wavelength range of the spectrum provided by the multichromatic light source.
22. The scanner system according to the preceding claim where the color filter array is such that its proportion of pixels with color filters that match the

selected wavelength range of the spectrum is larger than 50%, such a wherein the proportion equals 32/36, 60/64 or 96/100.

- 5 23. The scanner system according to claim 21 or 22, wherein the selected wavelength range matches the W2 wavelength range.
- 10 24. The scanner system according to any of claims 21 to 23, wherein the color filter array comprises a plurality of cells of 6x6 color filters, where the color filters in positions (2,2) and (5,5) of each cell are of the W1 type, the color filters in positions (2,5) and (5,2) are of the W3 type
- 15 25. The scanner system according to the preceding claim, where the remaining 32 color filters in the 6x6 cell are of the W2 type.
- 20 26. The scanner according to the preceding claim where the pattern generating element is configured to provide that the spatial pattern comprises alternating dark and bright regions arranged in a checkerboard pattern.
- 25 27. A scanner system for recording surface geometry and surface color of an object, the scanner system comprising:
- a multichromatic light source configured for providing a multichromatic probe light, and
 - a color image sensor comprising an array of image sensor pixels for capturing one or more 2D images of light received from said object,
- 30 where at least for a block of said image sensor pixels, both surface color information and surface geometry information of a part of the object are derived at least partly from one 2D image captured by said color image sensor.

28. A method of recording surface geometry and surface color of an object, the method comprising:

- obtaining a scanner system according to any of the previous claims;
- illuminating the surface of said object with multichromatic probe light
5 from said multichromatic light source;
- capturing a series of 2D images of said object using said color image sensor; and
- deriving both surface geometry information and surface color
10 information for a block of image sensor pixels at least partly from one captured 2D image.

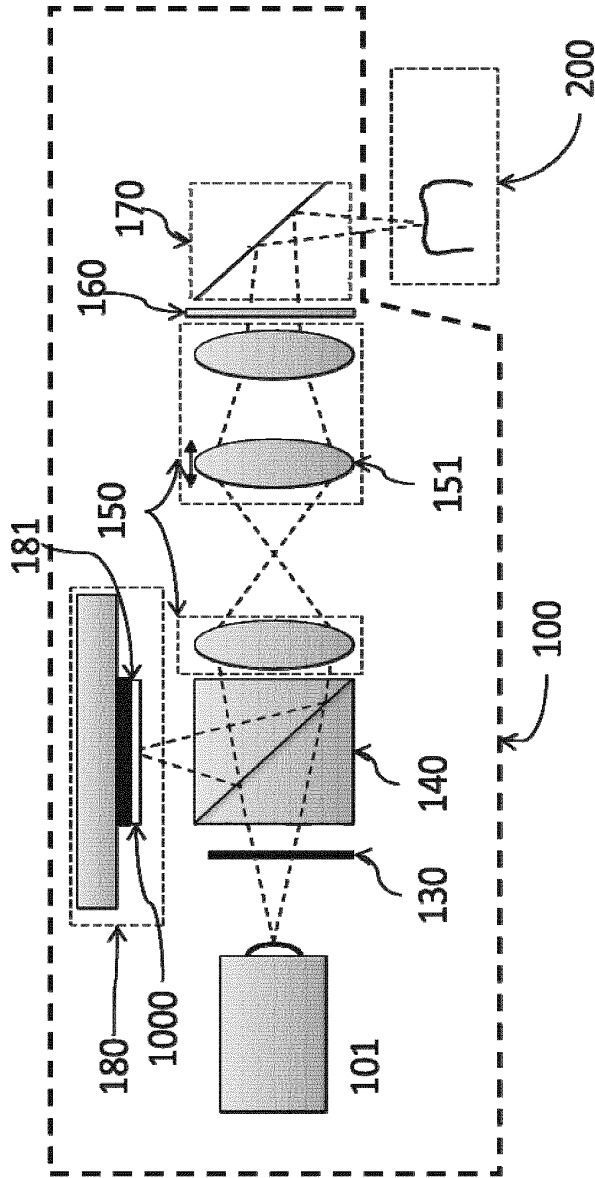

Fig. 1

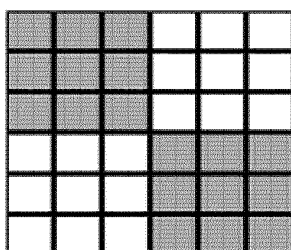

Fig. 2A

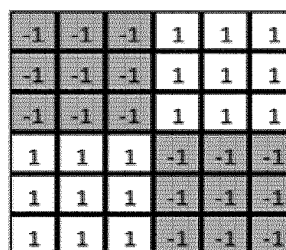

Fig. 2B

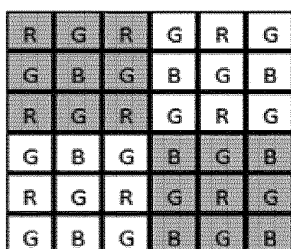

Fig. 3A

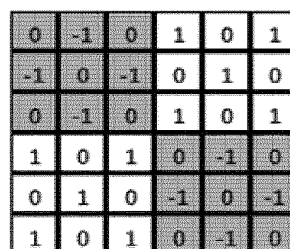

Fig. 3B

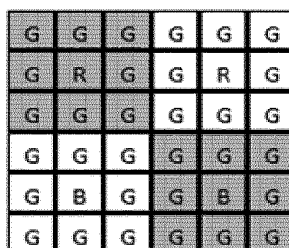

Fig. 4

541

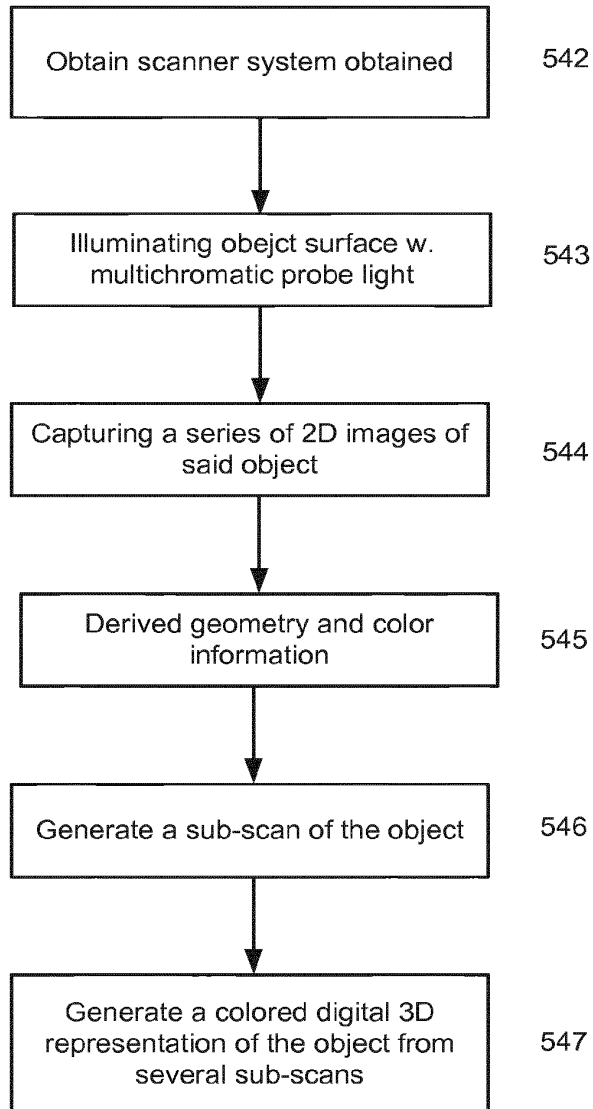
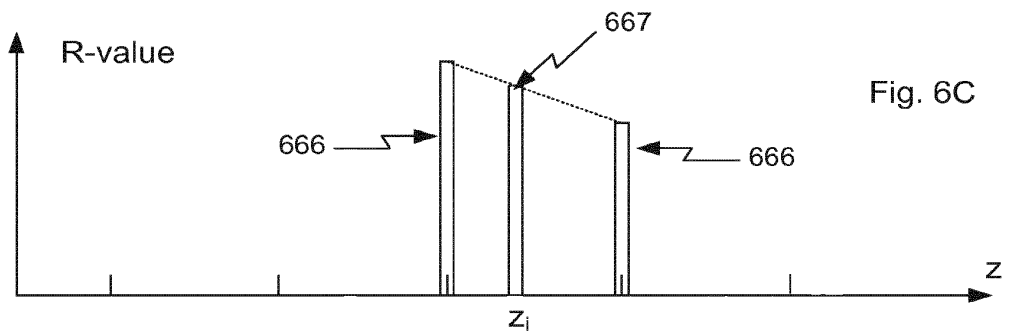
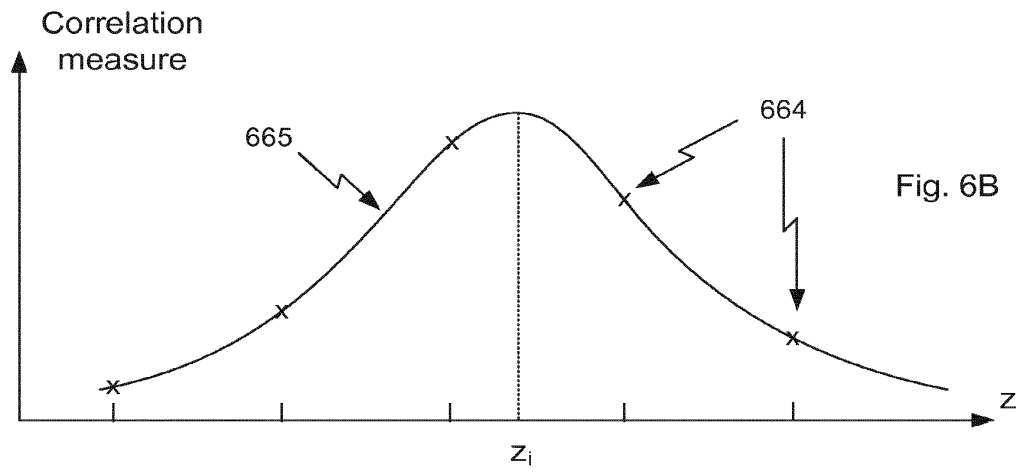
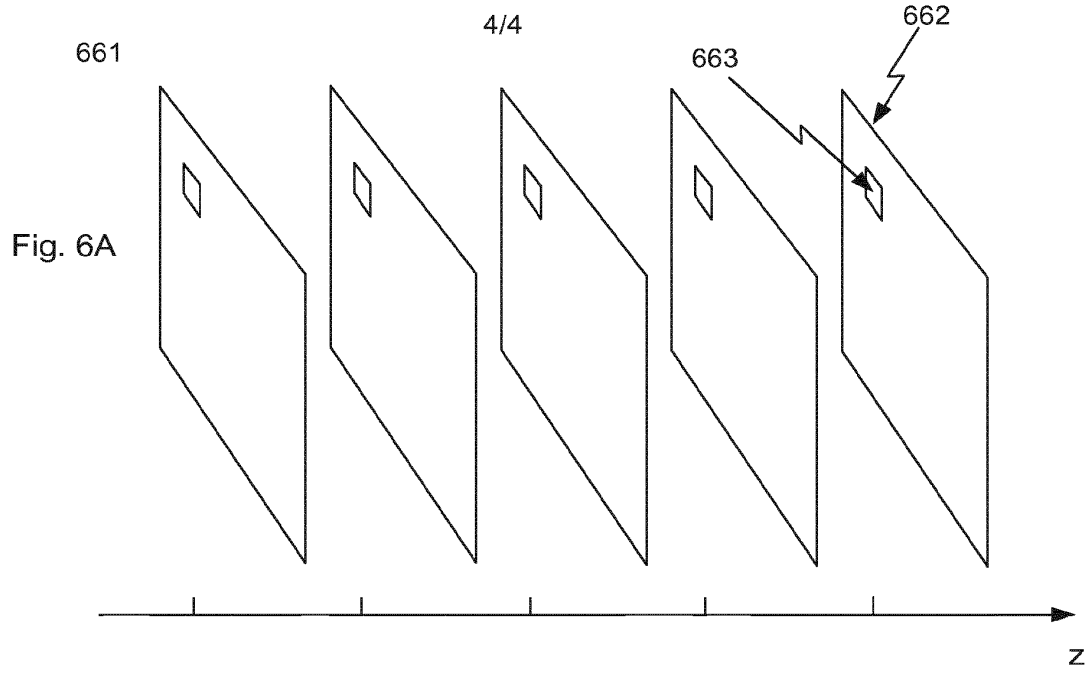

Fig. 5



SCORE Placeholder Sheet for IFW Content

Application Number: 14764087

Document Date: 07/28/2015

The presence of this form in the IFW record indicates that the following document type was received in electronic format on the date identified above. This content is stored in the SCORE database.

- Drawings – Other than Black and White Line Drawings

Since this was an electronic submission, there is no physical artifact folder, no artifact folder is recorded in PALM, and no paper documents or physical media exist. The TIFF images in the IFW record were created from the original documents that are stored in SCORE.

To access the documents in the SCORE database, refer to instructions below.

At the time of document entry (noted above):

- Examiners may access SCORE content via the eDAN interface.
- Other USPTO employees can bookmark the current SCORE URL (<http://Score.uspto.gov/ScoreAccessWeb/>).
- External customers may access SCORE content via the Public and Private PAIR interfaces.

Under the Paperwork Reduction Act of 1995, no persons are required to respond to a collection of information unless it displays a valid OMB control number.

PATENT APPLICATION FEE DETERMINATION RECORD Substitute for Form PTO-875	Application or Docket Number 14/764,087	Filing Date 07/28/2015	<input type="checkbox"/> To be Mailed
---	---	----------------------------------	---------------------------------------

ENTITY: LARGE SMALL MICRO

APPLICATION AS FILED – PART I

(Column 1) (Column 2)

FOR	NUMBER FILED	NUMBER EXTRA	RATE (\$)	FEE (\$)
<input type="checkbox"/> BASIC FEE (37 CFR 1.16(a), (b), or (c))	N/A	N/A	N/A	
<input type="checkbox"/> SEARCH FEE (37 CFR 1.16(k), (l), or (m))	N/A	N/A	N/A	
<input type="checkbox"/> EXAMINATION FEE (37 CFR 1.16(o), (p), or (q))	N/A	N/A	N/A	
TOTAL CLAIMS (37 CFR 1.16(i))	minus 20 = *	*	X \$ =	
INDEPENDENT CLAIMS (37 CFR 1.16(h))	minus 3 = *	*	X \$ =	
<input type="checkbox"/> APPLICATION SIZE FEE (37 CFR 1.16(s))	If the specification and drawings exceed 100 sheets of paper, the application size fee due is \$310 (\$155 for small entity) for each additional 50 sheets or fraction thereof. See 35 U.S.C. 41(a)(1)(G) and 37 CFR 1.16(s).			
<input type="checkbox"/> MULTIPLE DEPENDENT CLAIM PRESENT (37 CFR 1.16(j))				
* If the difference in column 1 is less than zero, enter "0" in column 2.			TOTAL	

APPLICATION AS AMENDED – PART II

(Column 1) (Column 2) (Column 3)

	07/28/2015	CLAIMS REMAINING AFTER AMENDMENT		HIGHEST NUMBER PREVIOUSLY PAID FOR	PRESENT EXTRA	RATE (\$)	ADDITIONAL FEE (\$)	
AMENDMENT	Total (37 CFR 1.16(o))	* 31	Minus	** 31	= 0	X \$80 =	0	
	Independent (37 CFR 1.16(b))	* 2	Minus	*** 2	= 0	X \$420 =	0	
	<input type="checkbox"/> Application Size Fee (37 CFR 1.16(s))							
	<input type="checkbox"/> FIRST PRESENTATION OF MULTIPLE DEPENDENT CLAIM (37 CFR 1.16(j))							
						TOTAL ADD'L FEE	0	

(Column 1) (Column 2) (Column 3)

		CLAIMS REMAINING AFTER AMENDMENT		HIGHEST NUMBER PREVIOUSLY PAID FOR	PRESENT EXTRA	RATE (\$)	ADDITIONAL FEE (\$)	
AMENDMENT	Total (37 CFR 1.16(o))	*	Minus	**	=	X \$ =		
	Independent (37 CFR 1.16(b))	*	Minus	***	=	X \$ =		
	<input type="checkbox"/> Application Size Fee (37 CFR 1.16(s))							
	<input type="checkbox"/> FIRST PRESENTATION OF MULTIPLE DEPENDENT CLAIM (37 CFR 1.16(j))							
						TOTAL ADD'L FEE		

* If the entry in column 1 is less than the entry in column 2, write "0" in column 3.
 ** If the "Highest Number Previously Paid For" IN THIS SPACE is less than 20, enter "20".
 *** If the "Highest Number Previously Paid For" IN THIS SPACE is less than 3, enter "3".
 The "Highest Number Previously Paid For" (Total or Independent) is the highest number found in the appropriate box in column 1.

LIE
/BRUCE HARRISON/

This collection of information is required by 37 CFR 1.16. The information is required to obtain or retain a benefit by the public which is to file (and by the USPTO to process) an application. Confidentiality is governed by 35 U.S.C. 122 and 37 CFR 1.14. This collection is estimated to take 12 minutes to complete, including gathering, preparing, and submitting the completed application form to the USPTO. Time will vary depending upon the individual case. Any comments on the amount of time you require to complete this form and/or suggestions for reducing this burden, should be sent to the Chief Information Officer, U.S. Patent and Trademark Office, U.S. Department of Commerce, P.O. Box 1450, Alexandria, VA 22313-1450. DO NOT SEND FEES OR COMPLETED FORMS TO THIS ADDRESS. **SEND TO: Commissioner for Patents, P.O. Box 1450, Alexandria, VA 22313-1450.**
 If you need assistance in completing the form, call 1-800-PTO-9199 and select option 2.



UNITED STATES PATENT AND TRADEMARK OFFICE

UNITED STATES DEPARTMENT OF COMMERCE
United States Patent and Trademark Office
Address: COMMISSIONER FOR PATENTS
P.O. Box 1459
Alexandria, Virginia 22313-1450
www.uspto.gov

Table with 7 columns: APPLICATION NUMBER, FILING or 371(c) DATE, GRP ART UNIT, FIL FEE REC'D, ATTY DOCKET NO, TOT CLAIMS, IND CLAIMS. Row 1: 14/764,087, 07/28/2015, 2500, 0079124-000111, 31, 2

CONFIRMATION NO. 6247

FILING RECEIPT

21839
BUCHANAN, INGERSOLL & ROONEY PC
POST OFFICE BOX 1404
ALEXANDRIA, VA 22313-1404



Date Mailed: 10/19/2015

Receipt is acknowledged of this non-provisional patent application. The application will be taken up for examination in due course. Applicant will be notified as to the results of the examination. Any correspondence concerning the application must include the following identification information: the U.S. APPLICATION NUMBER, FILING DATE, NAME OF APPLICANT, and TITLE OF INVENTION. Fees transmitted by check or draft are subject to collection. Please verify the accuracy of the data presented on this receipt. If an error is noted on this Filing Receipt, please submit a written request for a Filing Receipt Correction. Please provide a copy of this Filing Receipt with the changes noted thereon. If you received a "Notice to File Missing Parts" for this application, please submit any corrections to this Filing Receipt with your reply to the Notice. When the USPTO processes the reply to the Notice, the USPTO will generate another Filing Receipt incorporating the requested corrections

Inventor(s)

Bo ESBECH, Gentofte, DENMARK;
Christian Romer ROSBERG, Bronshoj, DENMARK;
Mike VAN DER POEL, Rodovre, DENMARK;
Rasmus KJAER, Kobenhavn K, DENMARK;
Michael VINTHER, Kobenhavn S, DENMARK;
Karl-Josef HOLLENBECK, Copenhagen O, DENMARK;

Applicant(s)

3SHAPE A/S, Copenhagen k, DENMARK;

Assignment For Published Patent Application

3SHAPE A/S, Copenhagen K, OT, DENMARK

Power of Attorney: The patent practitioners associated with Customer Number 21839

Domestic Priority data as claimed by applicant

This application is a 371 of PCT/EP2014/052842 02/13/2014
which claims benefit of 61/764,178 02/13/2013

Foreign Applications (You may be eligible to benefit from the Patent Prosecution Highway program at the USPTO. Please see http://www.uspto.gov for more information.)
DENMARK PA 2013 70077 02/13/2013 No Access Code Provided

If Required, Foreign Filing License Granted: 10/15/2015

The country code and number of your priority application, to be used for filing abroad under the Paris Convention, is US 14/764,087

Projected Publication Date: 01/28/2016

Non-Publication Request: No

Early Publication Request: No
Title

FOCUS SCANNING APPARATUS RECORDING COLOR

Preliminary Class

Statement under 37 CFR 1.55 or 1.78 for AIA (First Inventor to File) Transition Applications: No

PROTECTING YOUR INVENTION OUTSIDE THE UNITED STATES

Since the rights granted by a U.S. patent extend only throughout the territory of the United States and have no effect in a foreign country, an inventor who wishes patent protection in another country must apply for a patent in a specific country or in regional patent offices. Applicants may wish to consider the filing of an international application under the Patent Cooperation Treaty (PCT). An international (PCT) application generally has the same effect as a regular national patent application in each PCT-member country. The PCT process **simplifies** the filing of patent applications on the same invention in member countries, but **does not result** in a grant of "an international patent" and does not eliminate the need of applicants to file additional documents and fees in countries where patent protection is desired.

Almost every country has its own patent law, and a person desiring a patent in a particular country must make an application for patent in that country in accordance with its particular laws. Since the laws of many countries differ in various respects from the patent law of the United States, applicants are advised to seek guidance from specific foreign countries to ensure that patent rights are not lost prematurely.

Applicants also are advised that in the case of inventions made in the United States, the Director of the USPTO must issue a license before applicants can apply for a patent in a foreign country. The filing of a U.S. patent application serves as a request for a foreign filing license. The application's filing receipt contains further information and guidance as to the status of applicant's license for foreign filing.

Applicants may wish to consult the USPTO booklet, "General Information Concerning Patents" (specifically, the section entitled "Treaties and Foreign Patents") for more information on timeframes and deadlines for filing foreign patent applications. The guide is available either by contacting the USPTO Contact Center at 800-786-9199, or it can be viewed on the USPTO website at <http://www.uspto.gov/web/offices/pac/doc/general/index.html>.

For information on preventing theft of your intellectual property (patents, trademarks and copyrights), you may wish to consult the U.S. Government website, <http://www.stopfakes.gov>. Part of a Department of Commerce initiative, this website includes self-help "toolkits" giving innovators guidance on how to protect intellectual property in specific countries such as China, Korea and Mexico. For questions regarding patent enforcement issues, applicants may call the U.S. Government hotline at 1-866-999-HALT (1-866-999-4258).

**LICENSE FOR FOREIGN FILING UNDER
Title 35, United States Code, Section 184
Title 37, Code of Federal Regulations, 5.11 & 5.15**

GRANTED

The applicant has been granted a license under 35 U.S.C. 184, if the phrase "IF REQUIRED, FOREIGN FILING LICENSE GRANTED" followed by a date appears on this form. Such licenses are issued in all applications where the conditions for issuance of a license have been met, regardless of whether or not a license may be required as set forth in 37 CFR 5.15. The scope and limitations of this license are set forth in 37 CFR 5.15(a) unless an earlier license has been issued under 37 CFR 5.15(b). The license is subject to revocation upon written notification. The date indicated is the effective date of the license, unless an earlier license of similar scope has been granted under 37 CFR 5.13 or 5.14.

This license is to be retained by the licensee and may be used at any time on or after the effective date thereof unless it is revoked. This license is automatically transferred to any related applications(s) filed under 37 CFR 1.53(d). This license is not retroactive.

The grant of a license does not in any way lessen the responsibility of a licensee for the security of the subject matter as imposed by any Government contract or the provisions of existing laws relating to espionage and the national security or the export of technical data. Licensees should apprise themselves of current regulations especially with respect to certain countries, of other agencies, particularly the Office of Defense Trade Controls, Department of State (with respect to Arms, Munitions and Implements of War (22 CFR 121-128)); the Bureau of Industry and Security, Department of Commerce (15 CFR parts 730-774); the Office of Foreign Assets Control, Department of Treasury (31 CFR Parts 500+) and the Department of Energy.

NOT GRANTED

No license under 35 U.S.C. 184 has been granted at this time, if the phrase "IF REQUIRED, FOREIGN FILING LICENSE GRANTED" DOES NOT appear on this form. Applicant may still petition for a license under 37 CFR 5.12, if a license is desired before the expiration of 6 months from the filing date of the application. If 6 months has lapsed from the filing date of this application and the licensee has not received any indication of a secrecy order under 35 U.S.C. 181, the licensee may foreign file the application pursuant to 37 CFR 5.15(b).

SelectUSA

The United States represents the largest, most dynamic marketplace in the world and is an unparalleled location for business investment, innovation, and commercialization of new technologies. The U.S. offers tremendous resources and advantages for those who invest and manufacture goods here. Through SelectUSA, our nation works to promote and facilitate business investment. SelectUSA provides information assistance to the international investor community; serves as an ombudsman for existing and potential investors; advocates on behalf of U.S. cities, states, and regions competing for global investment; and counsels U.S. economic development organizations on investment attraction best practices. To learn more about why the United States is the best country in the world to develop technology, manufacture products, deliver services, and grow your business, visit <http://www.SelectUSA.gov> or call +1-202-482-6800.

PATENT APPLICATION FEE DETERMINATION RECORD					Application or Docket Number 14/764,087		
Substitute for Form PTO-875							
APPLICATION AS FILED - PART I							
(Column 1)		(Column 2)		SMALL ENTITY		OR	
FOR	NUMBER FILED	NUMBER EXTRA	RATE(\$)	FEE(\$)	RATE(\$)	FEE(\$)	
BASIC FEE (37 CFR 1.16(a), (b), or (c))	N/A	N/A	N/A		N/A	280	
SEARCH FEE (37 CFR 1.16(k), (l), or (m))	N/A	N/A	N/A		N/A	480	
EXAMINATION FEE (37 CFR 1.16(o), (p), or (q))	N/A	N/A	N/A		N/A	720	
TOTAL CLAIMS (37 CFR 1.16(i))	31	minus 20 = *	11		x 80 =	880	
INDEPENDENT CLAIMS (37 CFR 1.16(h))	2	minus 3 = *			x 420 =	0.00	
APPLICATION SIZE FEE (37 CFR 1.16(s))	If the specification and drawings exceed 100 sheets of paper, the application size fee due is \$310 (\$155 for small entity) for each additional 50 sheets or fraction thereof. See 35 U.S.C. 41(a)(1)(G) and 37 CFR 1.16(s).					0.00	
MULTIPLE DEPENDENT CLAIM PRESENT (37 CFR 1.16(j))						0.00	
* If the difference in column 1 is less than zero, enter "0" in column 2.				TOTAL		TOTAL 2360	
APPLICATION AS AMENDED - PART II							
(Column 1)		(Column 2)		(Column 3)		SMALL ENTITY	
AMENDMENT A	CLAIMS REMAINING AFTER AMENDMENT	HIGHEST NUMBER PREVIOUSLY PAID FOR	PRESENT EXTRA	RATE(\$)	ADDITIONAL FEE(\$)	RATE(\$)	
	Total (37 CFR 1.16(i))	*	Minus **	=	x	=	
	Independent (37 CFR 1.16(h))	*	Minus ***	=	x	=	
	Application Size Fee (37 CFR 1.16(s))						
	FIRST PRESENTATION OF MULTIPLE DEPENDENT CLAIM (37 CFR 1.16(j))						
				TOTAL ADD'L FEE		TOTAL ADD'L FEE	
(Column 1)		(Column 2)		(Column 3)		SMALL ENTITY	
AMENDMENT B	CLAIMS REMAINING AFTER AMENDMENT	HIGHEST NUMBER PREVIOUSLY PAID FOR	PRESENT EXTRA	RATE(\$)	ADDITIONAL FEE(\$)	RATE(\$)	
	Total (37 CFR 1.16(i))	*	Minus **	=	x	=	
	Independent (37 CFR 1.16(h))	*	Minus ***	=	x	=	
	Application Size Fee (37 CFR 1.16(s))						
	FIRST PRESENTATION OF MULTIPLE DEPENDENT CLAIM (37 CFR 1.16(j))						
				TOTAL ADD'L FEE		TOTAL ADD'L FEE	
<p>* If the entry in column 1 is less than the entry in column 2, write "0" in column 3.</p> <p>** If the "Highest Number Previously Paid For" IN THIS SPACE is less than 20, enter "20".</p> <p>*** If the "Highest Number Previously Paid For" IN THIS SPACE is less than 3, enter "3".</p> <p>The "Highest Number Previously Paid For" (Total or Independent) is the highest found in the appropriate box in column 1.</p>							



UNITED STATES PATENT AND TRADEMARK OFFICE

UNITED STATES DEPARTMENT OF COMMERCE
United States Patent and Trademark Office
Address: COMMISSIONER FOR PATENTS
P.O. Box 1450
Alexandria, Virginia 22313-1450
www.uspto.gov

Table with 3 columns: U.S. APPLICATION NUMBER NO. (14/764,087), FIRST NAMED INVENTOR (Bo ESBECH), ATTY. DOCKET NO. (0079124-000111). Includes fields for INTERNATIONAL APPLICATION NO. (PCT/EP2014/052842), LA. FILING DATE (02/13/2014), and PRIORITY DATE (02/13/2013).

21839
BUCHANAN, INGERSOLL & ROONEY PC
POST OFFICE BOX 1404
ALEXANDRIA, VA 22313-1404

INTERNATIONAL APPLICATION NO. (PCT/EP2014/052842)
LA. FILING DATE (02/13/2014)
PRIORITY DATE (02/13/2013)

CONFIRMATION NO. 6247
371 ACCEPTANCE LETTER



Date Mailed: 10/19/2015

NOTICE OF ACCEPTANCE OF APPLICATION UNDER 35 U.S.C 371 AND 37 CFR 1.495

The applicant is hereby advised that the United States Patent and Trademark Office, in its capacity as a Designated / Elected Office (37 CFR 1.495), has ACCEPTED the above identified international application for national patentability examination in the United States Patent and Trademark Office.

The United States Application Number assigned to the application is shown above. A Filing Receipt will be issued for the present application in due course. THE DATE APPEARING ON THE FILING RECEIPT AS THE "FILING DATE or 371(c) DATE" IS THE DATE ON WHICH THE LAST OF THE 35 U.S.C. 371 (c)(1) and (c)(2) REQUIREMENTS HAS BEEN RECEIVED IN THE OFFICE. THIS DATE IS SHOWN BELOW. The filing date of the above identified application is the international filing date of the international application (Article 11(3) and 35 U.S.C. 363)

07/28/2015
DATE OF RECEIPT OF 35 U.S.C.
371(c)(1) and (c)(2) REQUIREMENTS

The following items have been received:

- Copy of the International Application filed on 07/28/2015
• Copy of the International Search Report filed on 07/28/2015
• Preliminary Amendments filed on 07/28/2015
• Information Disclosure Statements filed on 07/28/2015
• U.S. Basic National Fees filed on 07/28/2015
• Substitute Specification filed on 07/28/2015
• Priority Documents filed on 07/28/2015
• Power of Attorney filed on 07/28/2015
• Application Data Sheet (37 CFR 1.76) filed on 07/28/2015

Applicant is notified that the above-identified application contains the deficiencies noted below. No period for reply is set forth in this notice for correction of these deficiencies. However, if a deficiency relates to the inventor's oath or declaration, the applicant must file an oath or declaration in compliance with 37 CFR 1.63, or a substitute statement in compliance with 37 CFR 1.64, executed by or with respect to each actual inventor no later than the expiration of the time period set in the "Notice of Allowability" to avoid abandonment. See 37 CFR 1.495(c).

- Properly executed inventor's oath or declaration for the following inventor(s) has not been submitted: Bo ESBECH, Christian Romer ROSBERG, Mike VAN DER POEL, Rasmus KJAER, Michael VINTHER, and Karl-Josef HOLLENBECK

Applicant is reminded that any communications to the United States Patent and Trademark Office must be mailed to the address given in the heading and include the U.S. application no. shown above (37 CFR 1.5)

VONDA M WALLACE

Telephone: (571) 272-3734

MULTIPLE DEPENDENT CLAIM FEE CALCULATION SHEET							Application Number		Filing Date			
Substitute for Form PTO-1360 (For use with Form PTO/SB/06)							14764087					
							Applicant(s) Bo ESBECH					
							* May be used for additional claims or amendments					
CLAIMS	AS FILED		AFTER FIRST AMENDMENT		AFTER SECOND AMENDMENT		-		-		-	
	Indep	Depend	Indep	Depend	Indep	Depend	Indep	Depend	Indep	Depend	Indep	Depend
1	1		1									
2		1		1								
3		2		1								
4		(1)		1								
5		(1)		1								
6		(1)		1								
7		(1)		1								
8		(1)		1								
9		(1)		1								
10		(1)		1								
11		(1)		1								
12		(1)		1								
13		(1)		1								
14		(1)		1								
15		(1)		1								
16		(1)		1								
17		(1)		1								
18		(1)		1								
19		(1)		1								
20		(1)		1								
21		(1)		1								
22		(1)		1								
23		(1)		1								
24		(1)		1								
25	1		1									
26		1		1								
27	1			1								
28		(1)		1								
29				1								
30				1								
31				1								
32												
33												
34												
35												
36												
37												
38												
39												
40												
41												
42												
43												
44												
45												
46												
47												
48												
49												
50												
Total Indep	3		2		0							
Total Depend	26	↙	29	↙	0	↙						
Total Claims	29		31		0							
51												
52												
53												
54												
55												
56												
57												
58												
59												
60												
61												
62												
63												
64												
65												
66												
67												
68												
69												
70												
71												
72												
73												
74												
75												
76												
77												
78												
79												
80												
81												
82												
83												
84												
85												
86												
87												
88												
89												
90												
91												
92												
93												
94												
95												
96												
97												
98												
99												
100												



UNITED STATES PATENT AND TRADEMARK OFFICE

UNITED STATES DEPARTMENT OF COMMERCE
United States Patent and Trademark Office
Address: COMMISSIONER FOR PATENTS
P.O. Box 1459
Alexandria, Virginia 22313-1450
www.uspto.gov

APPLICATION NUMBER	FILING OR 371(C) DATE	FIRST NAMED APPLICANT	ATTY. DOCKET NO./TITLE
14/764,087	07/28/2015	Bo ESBECH	0079124-000111

CONFIRMATION NO. 6247

21839
BUCHANAN, INGERSOLL & ROONEY PC
POST OFFICE BOX 1404
ALEXANDRIA, VA 22313-1404

PUBLICATION NOTICE



Title: FOCUS SCANNING APPARATUS RECORDING COLOR

Publication No.: US-2016-0022389-A1

Publication Date: 01/28/2016

NOTICE OF PUBLICATION OF APPLICATION

The above-identified application will be electronically published as a patent application publication pursuant to 37 CFR 1.211, et seq. The patent application publication number and publication date are set forth above.

The publication may be accessed through the USPTO's publicly available Searchable Databases via the Internet at www.uspto.gov. The direct link to access the publication is currently <http://www.uspto.gov/patft/>.

The publication process established by the Office does not provide for mailing a copy of the publication to applicant. A copy of the publication may be obtained from the Office upon payment of the appropriate fee set forth in 37 CFR 1.19(a)(1). Orders for copies of patent application publications are handled by the USPTO's Office of Public Records. The Office of Public Records can be reached by telephone at (703) 308-9726 or (800) 972-6382, by facsimile at (703) 305-8759, by mail addressed to the United States Patent and Trademark Office, Office of Public Records, Alexandria, VA 22313-1450 or via the Internet.

In addition, information on the status of the application, including the mailing date of Office actions and the dates of receipt of correspondence filed in the Office, may also be accessed via the Internet through the Patent Electronic Business Center at www.uspto.gov using the public side of the Patent Application Information and Retrieval (PAIR) system. The direct link to access this status information is currently <http://pair.uspto.gov/>. Prior to publication, such status information is confidential and may only be obtained by applicant using the private side of PAIR.

Further assistance in electronically accessing the publication, or about PAIR, is available by calling the Patent Electronic Business Center at 1-866-217-9197.

Office of Data Management, Application Assistance Unit (571) 272-4000, or (571) 272-4200, or 1-888-786-0101

PATENT ASSIGNMENT COVER SHEET

Electronic Version v1.1
 Stylesheet Version v1.2

EPAS ID: PAT3731187

SUBMISSION TYPE:	NEW ASSIGNMENT
NATURE OF CONVEYANCE:	ASSIGNMENT
CONVEYING PARTY DATA	
Name	Execution Date
BO ESBECH	12/08/2015
CHRISTIAN ROMER ROSBERG	01/13/2016
MIKE VAN DER POEL	12/08/2015
RASMUS KJAER	12/08/2015
MICHAEL VINTHER	12/08/2015
KARL-JOSEF HOLLENBECK	12/08/2015
RECEIVING PARTY DATA	
Name:	3SHAPE A/S
Street Address:	HOLMENS KANAL 7
City:	COPENHAGEN K
State/Country:	DENMARK
Postal Code:	DK-1060
PROPERTY NUMBERS Total: 1	
Property Type	Number
Application Number:	14764087
CORRESPONDENCE DATA	
Fax Number:	(703)836-2021
<i>Correspondence will be sent to the e-mail address first; if that is unsuccessful, it will be sent using a fax number, if provided; if that is unsuccessful, it will be sent via US Mail.</i>	
Phone:	703-836-6620
Email:	stacey.pflieger@bipc.com
Correspondent Name:	BUCHANAN INGERSOLL & ROONEY
Address Line 1:	1737 KING STREET
Address Line 4:	ALEXANDRIA, VIRGINIA 22314
ATTORNEY DOCKET NUMBER:	0079124-000111
NAME OF SUBMITTER:	STACEY PFLIEGER
SIGNATURE:	/StaceyPflieger/
DATE SIGNED:	02/09/2016
This document serves as an Oath/Declaration (37 CFR 1.63).	

Total Attachments: 3

source=111assgn#page1.tif

source=111assgn#page2.tif

source=111assgn#page3.tif

COMBINED DECLARATION AND ASSIGNMENT (JOINT)

As one of the below named inventors, I hereby declare that this Combined Declaration and Assignment is directed to:

- (1) PCT application number PCT/EP2014/052842, filed on February 13, 2014, entitled FOCUS SCANNING APPARATUS RECORDING COLOR; or
- (2) the attached application entitled _____.

DECLARATION

As one of the below named inventors, I further declare that:

The above-identified application was made or authorized to be made by me.

I believe that I am an original joint inventor of a claimed invention in the application.

I have reviewed and understand the contents of the above-identified application, including the claims.

I acknowledge the duty to disclose to the U.S. Patent and Trademark Office all information known to me to be material to patentability as defined in Title 37, Code of Federal Regulations, § 1.56.

I hereby acknowledge that any willful false statement made in this declaration is punishable under 18 U.S.C. 1001 by fine or imprisonment of not more than five (5) years, or both.

ASSIGNMENT

THIS ASSIGNMENT, by the undersigned inventors (hereinafter referred to as "the Assignors"), respectively, witnesseth:

WHEREAS, the Assignors have invented certain new and useful improvements set forth in an application for Letters Patent of the United States, which is a nonprovisional application;

WHEREAS, 3SHAPE A/S, a corporation duly organized under and pursuant to the laws of Denmark and having a principal place of business at Holmens Kanal 7, DK-1060 Copenhagen K, Denmark (hereinafter referred to as "the Assignee"), is desirous of acquiring the entire right, title, and interest in and to said inventions, the right to file applications on said inventions and the entire right, title and interest in and to any applications, including provisional applications for Letters Patent of the United States or other countries claiming priority to said application, and in and to any Letters Patent or Patents, United States or foreign, to be obtained therefor and thereon.



NOW, THEREFORE, for good and sufficient consideration, the receipt of which is hereby acknowledged, the Assignors have sold, assigned, transferred, and set over, and by these presents do sell, assign, transfer, and set over, unto the Assignee, its successors, legal representatives, and assigns the entire right, title, and interest in and to the above-mentioned inventions, the right to file applications on said inventions and the entire right, title and interest in and to any applications for Letters Patent of the United States or other countries claiming priority to said applications, and any and all Letters Patent or Patents of the United States of America and all foreign countries that may be granted therefor and thereon, and in and to any and all applications claiming priority to said applications, divisions, continuations, and continuations-in-part of said applications, and reissues and extensions of said Letters Patent or Patents, and all rights under the International

Convention for the Protection of Industrial Property, the same to be held and enjoyed by the Assignee, for its own use and behoof and the use and behoof of its successors, legal representatives, and assigns, to the full end of the term or terms for which Letters Patent or Patents may be granted as fully and entirely as the same would have been held and enjoyed by the Assignors had this sale and assignment not been made;

AND for the same consideration, the Assignors hereby covenant and agree to and with the Assignee, its successors, legal representatives, and assigns, that, at the time of execution and delivery of these presents, the Assignors are the sole and lawful owners of the entire right, title, and interest in and to the inventions set forth in said applications and said applications, including provisional applications, above-mentioned, and that the same are unencumbered, and that the Assignors have good and full right and lawful authority to sell and convey the same in the manner herein set forth;

AND for the same consideration, the Assignors hereby covenant and agree to and with the Assignee, its successors, legal representatives, and assigns that the Assignors will, whenever counsel of the Assignee, or the counsel of its successors, legal representatives, and assigns, shall advise that any proceeding in connection with said inventions or said applications for Letters Patent or Patents, or any proceeding in connection with Letters Patent or Patents for said inventions in any country, including interference proceedings, is lawful and desirable, or that any application claiming priority to said application, division, continuation, or continuation-in-part of any applications for Letters Patent or Patents, or any reissue or extension of any Letters Patent or Patents to be obtained thereon, is lawful and desirable, sign all papers and documents, take all lawful oaths, and do all acts necessary or required to be done for the procurement, maintenance, enforcement, and defense of Letters Patent or Patents for said inventions, without charge to the Assignee, its successors, legal representatives, and assigns, but at the cost and expense of the Assignee, its successors, legal representatives, and assigns;

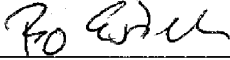
AND the Assignors hereby request the Commissioner of Patents to issue any and all said Letters Patent of the United States to the Assignee as the Assignee of said inventions, the Letters Patent to be issued for the sole use and behoof of the Assignee, its successors, legal representatives, and assigns.

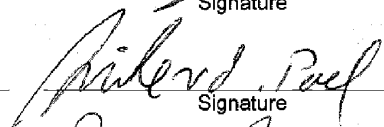
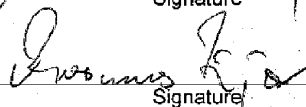
<u>8/12-2015</u> Date	<u>BO ESBECH</u> Name	<u></u> Signature
<u>13/1 - 2016</u> Date	<u>CHRISTIAN ROMER ROSBERG</u> Name	<u></u> Signature
<u>8/12 - 2015</u> Date	<u>MIKE VAN DER POEL</u> Name	<u></u> Signature
<u>8/12-2015</u> Date	<u>RASMUS KJÆR</u> Name	<u></u> Signature

8/12-15
Date

MICHAEL VINTHER
Name

M. Vinther
Signature

8/12-15
Date

KARL-JOSEF HOLLENBECK
Name

K. Hollenbeck
Signature

Doc code: IDS

Doc description: Information Disclosure Statement (IDS) Filed

PTO/SB/08a (01-10)

Approved for use through 07/31/2012. OMB 0651-0031

U.S. Patent and Trademark Office; U.S. DEPARTMENT OF COMMERCE

Under the Paperwork Reduction Act of 1995, no persons are required to respond to a collection of information unless it contains a valid OMB control number.

INFORMATION DISCLOSURE STATEMENT BY APPLICANT (Not for submission under 37 CFR 1.99)	Application Number	14764087
	Filing Date	2015-07-28
	First Named Inventor	Bo ESBECH et al.
	Art Unit	2878
	Examiner Name	EPPS, GEORGIA Y
	Attorney Docket Number	0079124-000111

U.S.PATENTS Remove

Examiner Initial*	Cite No	Patent Number	Kind Code ¹	Issue Date	Name of Patentee or Applicant of cited Document	Pages,Columns,Lines where Relevant Passages or Relevant Figures Appear
	1					

If you wish to add additional U.S. Patent citation information please click the Add button. Add

U.S.PATENT APPLICATION PUBLICATIONS Remove

Examiner Initial*	Cite No	Publication Number	Kind Code ¹	Publication Date	Name of Patentee or Applicant of cited Document	Pages,Columns,Lines where Relevant Passages or Relevant Figures Appear
	1	20100145898	A1	2010-06-10	Malfliet et al.	
	2	20110134225	A1	2011-06-09	Saint-Pierre et al.	(Corresponds to CN 102112845)
	3	20120062716	A1	2012-03-15	Dillon et al.	(Corresponds to CN 102402799)
	4	20130236850	A1	2013-09-12	Wu et al.	(Corresponds to CN 102008282)

If you wish to add additional U.S. Published Application citation information please click the Add button. Add

FOREIGN PATENT DOCUMENTS Remove

Examiner Initial*	Cite No	Foreign Document Number ³	Country Code ² i	Kind Code ⁴	Publication Date	Name of Patentee or Applicant of cited Document	Pages,Columns,Lines where Relevant Passages or Relevant Figures Appear	T ⁵
-------------------	---------	--------------------------------------	-----------------------------	------------------------	------------------	---	--	----------------

INFORMATION DISCLOSURE STATEMENT BY APPLICANT (Not for submission under 37 CFR 1.99)	Application Number		14764087	
	Filing Date		2015-07-28	
	First Named Inventor	Bo ESBECH et al.		
	Art Unit	2878		
	Examiner Name	EPPS, GEORGIA Y		
	Attorney Docket Number	0079124-000111		

1	102008282	CN	A	2011-04-13	Univ Shenzhen	(with English Abstract)
2	102112845	CN	A	2011-06-29	Creaform Inc	(with English Abstract)
3	102402799	CN	A	2012-04-04	Dimensional Photonics Internat Inc	(with English Abstract)
4	102802520	CN	A	2012-11-28	3Shape AS	(with English Abstract) (Corresponds to US 2012/0092461 and WO 2010/145669 previously cited on
5	2012/007003	WO	A1	2012-01-19	3Shape AS	

If you wish to add additional Foreign Patent Document citation information please click the Add button

NON-PATENT LITERATURE DOCUMENTS

Examiner Initials*	Cite No	Include name of the author (in CAPITAL LETTERS), title of the article (when appropriate), title of the item (book, magazine, journal, serial, symposium, catalog, etc), date, pages(s), volume-issue number(s), publisher, city and/or country where published.	T ⁵
	1	The First Office Action issued on August 2, 2016, by the State Intellectual Property Office of People's Republic of China in corresponding Chinese Patent Application No. 201480020976.3, and an English Translation of the Office Action. (18 pages)	X
	2	The First Chinese Search issued on July 25, 2016, by the State Intellectual Property Office of People's Republic of China in corresponding Chinese Patent Application No. 201480020976.3. (2 pages)	<input type="checkbox"/>

If you wish to add additional non-patent literature document citation information please click the Add button

EXAMINER SIGNATURE

Examiner Signature	<input type="text"/>	Date Considered	<input type="text"/>
--------------------	----------------------	-----------------	----------------------

*EXAMINER: Initial if reference considered, whether or not citation is in conformance with MPEP 609. Draw line through a citation if not in conformance and not considered. Include copy of this form with next communication to applicant.

INFORMATION DISCLOSURE STATEMENT BY APPLICANT (Not for submission under 37 CFR 1.99)	Application Number	14764087
	Filing Date	2015-07-28
	First Named Inventor	Bo ESBECH et al.
	Art Unit	2878
	Examiner Name	EPPS, GEORGIA Y
	Attorney Docket Number	0079124-000111

¹ See Kind Codes of USPTO Patent Documents at www.USPTO.GOV or MPEP 901.04. ² Enter office that issued the document, by the two-letter code (WIPO Standard ST.3). ³ For Japanese patent documents, the indication of the year of the reign of the Emperor must precede the serial number of the patent document. ⁴ Kind of document by the appropriate symbols as indicated on the document under WIPO Standard ST.16 if possible. ⁵ Applicant is to place a check mark here if English language translation is attached.

INFORMATION DISCLOSURE STATEMENT BY APPLICANT (Not for submission under 37 CFR 1.99)	Application Number	14764087
	Filing Date	2015-07-28
	First Named Inventor	Bo ESBECH et al.
	Art Unit	2878
	Examiner Name	EPPS, GEORGIA Y
	Attorney Docket Number	0079124-000111

CERTIFICATION STATEMENT

Please see 37 CFR 1.97 and 1.98 to make the appropriate selection(s):

That each item of information contained in the information disclosure statement was first cited in any communication from a foreign patent office in a counterpart foreign application not more than three months prior to the filing of the information disclosure statement. See 37 CFR 1.97(e)(1).

OR

That no item of information contained in the information disclosure statement was cited in a communication from a foreign patent office in a counterpart foreign application, and, to the knowledge of the person signing the certification after making reasonable inquiry, no item of information contained in the information disclosure statement was known to any individual designated in 37 CFR 1.56(c) more than three months prior to the filing of the information disclosure statement. See 37 CFR 1.97(e)(2).

See attached certification statement.

The fee set forth in 37 CFR 1.17 (p) has been submitted herewith.

A certification statement is not submitted herewith.

SIGNATURE

A signature of the applicant or representative is required in accordance with CFR 1.33, 10.18. Please see CFR 1.4(d) for the form of the signature.

Signature	/WCRowland/	Date (YYYY-MM-DD)	2016-08-26
Name/Print	William C. Rowland	Registration Number	30,888

This collection of information is required by 37 CFR 1.97 and 1.98. The information is required to obtain or retain a benefit by the public which is to file (and by the USPTO to process) an application. Confidentiality is governed by 35 U.S.C. 122 and 37 CFR 1.14. This collection is estimated to take 1 hour to complete, including gathering, preparing and submitting the completed application form to the USPTO. Time will vary depending upon the individual case. Any comments on the amount of time you require to complete this form and/or suggestions for reducing this burden, should be sent to the Chief Information Officer, U.S. Patent and Trademark Office, U.S. Department of Commerce, P.O. Box 1450, Alexandria, VA 22313-1450. **DO NOT SEND FEES OR COMPLETED FORMS TO THIS ADDRESS. SEND TO: Commissioner for Patents, P.O. Box 1450, Alexandria, VA 22313-1450.**

Privacy Act Statement

The Privacy Act of 1974 (P.L. 93-579) requires that you be given certain information in connection with your submission of the attached form related to a patent application or patent. Accordingly, pursuant to the requirements of the Act, please be advised that: (1) the general authority for the collection of this information is 35 U.S.C. 2(b)(2); (2) furnishing of the information solicited is voluntary; and (3) the principal purpose for which the information is used by the U.S. Patent and Trademark Office is to process and/or examine your submission related to a patent application or patent. If you do not furnish the requested information, the U.S. Patent and Trademark Office may not be able to process and/or examine your submission, which may result in termination of proceedings or abandonment of the application or expiration of the patent.

The information provided by you in this form will be subject to the following routine uses:

1. The information on this form will be treated confidentially to the extent allowed under the Freedom of Information Act (5 U.S.C. 552) and the Privacy Act (5 U.S.C. 552a). Records from this system of records may be disclosed to the Department of Justice to determine whether the Freedom of Information Act requires disclosure of these records.
2. A record from this system of records may be disclosed, as a routine use, in the course of presenting evidence to a court, magistrate, or administrative tribunal, including disclosures to opposing counsel in the course of settlement negotiations.
3. A record in this system of records may be disclosed, as a routine use, to a Member of Congress submitting a request involving an individual, to whom the record pertains, when the individual has requested assistance from the Member with respect to the subject matter of the record.
4. A record in this system of records may be disclosed, as a routine use, to a contractor of the Agency having need for the information in order to perform a contract. Recipients of information shall be required to comply with the requirements of the Privacy Act of 1974, as amended, pursuant to 5 U.S.C. 552a(m).
5. A record related to an International Application filed under the Patent Cooperation Treaty in this system of records may be disclosed, as a routine use, to the International Bureau of the World Intellectual Property Organization, pursuant to the Patent Cooperation Treaty.
6. A record in this system of records may be disclosed, as a routine use, to another federal agency for purposes of National Security review (35 U.S.C. 181) and for review pursuant to the Atomic Energy Act (42 U.S.C. 218(c)).
7. A record from this system of records may be disclosed, as a routine use, to the Administrator, General Services, or his/her designee, during an inspection of records conducted by GSA as part of that agency's responsibility to recommend improvements in records management practices and programs, under authority of 44 U.S.C. 2904 and 2906. Such disclosure shall be made in accordance with the GSA regulations governing inspection of records for this purpose, and any other relevant (i.e., GSA or Commerce) directive. Such disclosure shall not be used to make determinations about individuals.
8. A record from this system of records may be disclosed, as a routine use, to the public after either publication of the application pursuant to 35 U.S.C. 122(b) or issuance of a patent pursuant to 35 U.S.C. 151. Further, a record may be disclosed, subject to the limitations of 37 CFR 1.14, as a routine use, to the public if the record was filed in an application which became abandoned or in which the proceedings were terminated and which application is referenced by either a published application, an application open to public inspections or an issued patent.
9. A record from this system of records may be disclosed, as a routine use, to a Federal, State, or local law enforcement agency, if the USPTO becomes aware of a violation or potential violation of law or regulation.



Espacenet

Bibliographic data: CN102008282 (A) — 2011-04-13**Number stamp intraoral scanner and oral cavity internal surface topography image real-time reconstructing system****Inventor(s):** QINGYANG WU; BIN HUI; XIANGDONG GONG; JINGZHEN LI ±
(WU QINGYANG, ; HUI BIN, ; GONG XIANGDONG, ; LI JINGZHEN)**Applicant(s):** UNIV SHENZHEN ± (SHENZHEN UNIVERSITY)**Classification:** - **international:** A61B1/04; A61B1/24; A61C19/04; G06T17/00
- **cooperative:** A61B1/00172; A61B1/24; A61C9/006; G01B11/24;
A61B1/04; A61B1/0684**Application number:** CN20101526092 20101029**Priority number (s):** CN20101526092 20101029**Also published as:** CN102008282 (B) US2013236850 (A1) US9149348 (B2)
WO2012055347 (A1)**Abstract of CN102008282 (A)**

The invention is suitable for medical equipment and provides a number stamp intraoral scanner which is provided with a window for limiting the size of the collection range. The number stamp intraoral scanner comprises a three-color light emitting diode (LED) light source module, a micro lens array plate, a collimation lens assembly, a gray scale coding grating plate, an optical deflector, a projecting lens assembly, a first reflector, a second reflector, a third reflector and a camera, wherein the second reflector and the third reflector are arranged in parallel, and the reflecting surfaces of the second reflector and the third reflector are opposite.; In the invention, the number stamp intraoral scanner can scan the interior of the oral cavity of human body directly, acquires the novel number stamp of a three-dimensional surface shape of tooth bodies and soft tissues in real time and meets the requirements that dentists and oral cavity technicians can obtain the oral cavity stamp rapidly and accurately.

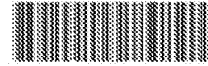

(12)发明专利申请

(10)申请公布号 CN 102008282 A

(43)申请公布日 2011.09.13

(21)申请号 201010526092.9

(22)申请日 2010.10.29

(71)申请人 深圳大学

地址 518060 广东省深圳市南山区南海大道
3688号

(72)发明人 吴庆阳 惠彬 龚向东 李景镇

(74)专利代理机构 深圳市威世博知识产权代理
事务所(普通合伙) 44280

代理人 何青瓦

(51)Int. Cl.

A61B 1/24(2006.01)

A61B 1/04(2006.01)

A61C 19/09(2006.01)

G06T 17/00(2006.01)

权利要求书 1 页 说明书 3 页 附图 1 页

(54)发明名称

数字印模口内扫描仪及口腔内表面形貌图像
实时重建系统

(57)摘要

本发明适用于医疗器械领域,提供了一种数字印模口内扫描仪,具有一限制采集范围大小的窗口,沿光路方向依次包括三色LED光源模组、透镜阵列板、准直透镜组、灰度编码光栅板、光学偏转器、投影透镜组、第一反射镜、平行放置且反射面相对的第二反射镜和第三反射镜、摄像头。本发明提供的数字印模口内扫描仪能够实现直接在人体口腔内部进行扫描,实时获取牙体和软组织三维面形的新型数字印模,可以满足口腔科医生和口腔技师快速、准确获取口腔印模的要求。

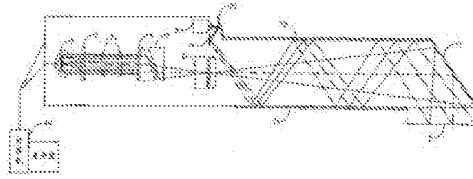

1. 一种数字印模口内扫描仪，其特征在于，所述数字印模口内扫描仪具有一限制采集范围大小的窗口；所述数字印模口内扫描仪沿光路方向依次包括：

三色 LED 光源模组；

微透镜阵列板，用于将所述三色 LED 光源模组产生的光束分布变均匀；

准直透镜组，用于将光束进行准直；

灰度编码光栅板，用于产生投影所需的灰度编码条纹图像；

光学偏转器，用于将光线进行偏移，对不同波长的光线的偏移距离不同；

投影透镜组，用于将经过所述灰度编码光栅板和所述光学偏转器的灰度编码光栅图像投影到被测物体表面；

第一反射镜，改变投影光路，使投影光线从所述窗口射出；

平行放置且反射面相对的第二反射镜和第三反射镜，用于保证光线能够在—个受限的空间内进行长距离传递；

摄像头，用于将口腔内表面的条纹分布进行成像、采集和记录。

2. 如权利要求 1 所述的数字印模口内扫描仪，其特征在于，所述三色 LED 光源模组包括三色 LED 光源和罩于所述三色 LED 光源外部的反光碗。

3. 如权利要求 1 所述的数字印模口内扫描仪，其特征在于，在所述摄像头之前，所述数字印模口内扫描仪还包括：

第四反射镜和 / 或第五反射镜，用于改变经过所述第二反射镜和第三反射镜反射的光的光路，使光线能够进入摄像头。

4. 如权利要求 1 所述的数字印模口内扫描仪，其特征在于，所述光学偏转器由一对形状完全相同，且具有直角边的楔形棱镜组成。

5. 一种口腔内表面形貌图像实时重建系统，其特征在于，包括如权利要求 1 至 4 任—项所述的数字印模口内扫描仪；还包括计算机系统和同步控制电路系统；

所述同步控制电路系统用于控制所述三色 LED 光源模组的频闪频率和所述摄像头的采集频率同步；

所述计算机系统用于根据所述数字印模口内扫描仪采集到的条纹图像进行口腔内表面形貌的实时重建。

数字印模口内扫描仪及口腔内表面形貌图像实时重建系统

技术领域

[0001] 本发明属于医疗器械领域，尤其涉及一种数字印模口内扫描仪及口腔内表面形貌图像实时重建系统。

背景技术

[0002] 在临床口腔诊疗和修复过程中，口腔印模是一种重要的信息存储源，几乎每个患者都需要印取一副甚至多副印模。医生通过治疗前、中、后等多副模型的对比，即可了解治疗的效果，提高检查、诊断和治疗的准确性，而口腔技师也需要根据印模来确定义齿修复体的形态。

[0003] 目前，易操作、高精度、存储方便的数字印模技术越来越受到口腔医学界的重视，越来越多的学者和公司投入了大量的精力和财力对此进行研究。数字印模获取的方式根据扫描的位置分为两大类，即口外扫描和口内扫描，其中口内扫描是近两年国外出现的一种新的扫描方式。口内扫描将探测器伸入病人的口内直接对牙体进行测量，实时获取数字印模。与口外扫描相比，它有着更多的优越性。首先，提高了病人的满意度。其次，对医生来说，进一步改进了印模的品质，减少了椅边操作的步骤，节约了宝贵的时间，大大降低了材料和人工的消耗，并为医生的操作提供了有效的导引。最后也是最为重要的，它还为病人和医生之间建立起一个交流的平台，医生和病人可以根据获取的数字印模进行讨论，既可以使病人了解到自己的病情和医生的修复意图，也可以让医生更好的根据病人的需求来制定或者修正治疗方案，使医患关系更加融洽。

[0004] 由于口内实时扫描的特殊性，除了要求探测器小巧（可以伸入口腔内部）之外，还要求扫描尽可能的快速。因此现在需要一种可直接在人体口腔内部进行扫描并实时获取扫描结果的口内扫描技术。

发明内容

[0005] 本发明的目的在于提供一种数字印模口内扫描仪，旨在实现可直接在人体口腔内部进行扫描，实时获取牙体和软组织等口腔内表面的三维面形数据。

[0006] 本发明是这样实现的，一种数字印模口内扫描仪，所述数字印模口内扫描仪具有一限制采集范围大小的窗口；所述数字印模口内扫描仪沿光路方向依次包括：

[0007] 三色 LED 光源模组；

[0008] 微透镜阵列板，用于将所述三色 LED 光源模组产生的光束分布变均匀；

[0009] 准直透镜组，用于将光束进行准直；

[0010] 灰度编码光栅板，用于产生投影所需的灰度编码条纹图像；

[0011] 光学偏转器，用于将光线进行偏移，对不同波长的光线的偏移距离不同；

[0012] 投影透镜组，用于将经过所述灰度编码光栅板和所述光学偏转器的灰度编码光栅图像投影到被测物体表面；

[0013] 第一反射镜，改变投影光路，使投影光线从所述窗口射出；

[0014] 平行放置且反射面相对的第二反射镜和第三反射镜，用于保证光线能够在—个受限的空间内进行长距离传递；

[0015] 摄像头，用于将口腔内表面的条纹分布进行成像、采集和记录。

[0016] 本发明还提供了一种口腔内表面形貌图像实时重建系统，包括如上所述的数字印模口内扫描仪；还包括计算机系统和同步控制电路系统；

[0017] 所述同步控制电路系统用于控制所述三色 LED 光源模组的频闪频率和所述摄像头的采集频率同步；

[0018] 所述计算机系统用于根据所述数字印模口内扫描仪采集到的条纹图像进行口腔内表面形貌的实时重建。

[0019] 本发明提供的数字印模口内扫描仪能够实现直接在人体口腔内部进行扫描，实时获取牙体和软组织三维面形的新型数字印模，可以满足口腔科医生和口腔技师对快速、准确获取口腔印模的要求，该技术利用了当不同波长（颜色）的光线通过光学偏转器后的偏移距离不同，从而实现了投影在被测物体表面的条纹图像的精确相移；使用两个平行的平面反射镜，延长了成像光路，使窗口外的图像可以在一个狭窄的空间内传播，有利于数字印模口内扫描仪整体的小型化；同时利用同步电路将三色 LED 光源中三种波长（颜色）光频闪频率和摄像头的快门频率同步起来，实现了实时的数据采集。

附图说明

[0020] 图 1 是本发明实施例提供的口腔内表面形貌图像实时重建系统的架构原理图。

具体实施方式

[0021] 为了使本发明的目的、技术方案及优点更加清楚明白，以下结合附图及实施例，对本发明进行进一步详细说明。应当理解，此处所描述的具体实施例仅仅用以解释本发明，并不用于限定本发明。

[0022] 本发明实施例中，根据口内实时扫描的速度与精度需要以及口腔内表面形状复杂、高矮参差不齐的特点，采用主动投影结构光场到牙体表面形成编码条纹图像，并用成像设备从与投影光路成一角度的位置记录下带有编码条纹图像的牙体形貌图像。然后通过编码信息提取出物体表面的位置和高度信息，最终实现对牙体和周围软组织三维面形的实时重建。

[0023] 图 1 示出了本发明实施例提供的口腔内表面形貌图像实时重建系统的架构原理，为了便于描述，仅示出了与本实施例相关的部分。

[0024] 参照图 1，口腔内表面形貌图像实时重建系统包括三色 LED 光源模组 1、微透镜阵列板 2、准直透镜组 3、灰度编码光栅板 4、光学偏转器 5、投影透镜组 6、第一平面反射镜 71、第二平面反射镜 72、第三平面反射镜 73、第四平面反射镜 74、第五平面反射镜 75、摄像头 8、窗口 9 以及计算机系统 10。其中，三色 LED 光源模组 1 由三色 LED 光源和罩于所述三色 LED 光源外部的反光碗组成，第二平面反射镜 72 与第三平面反射镜 73 平行放置且反射面相对，而光学偏转器 5 由一对形状完全相同，且具有直角边的楔形棱镜组成。三色 LED 光源用于依次产生不同波长（颜色）的投影光线，例如可以采用红、绿、兰三色 LED 光源，该投影光线经过微透镜阵列板 2 后光照分布比较均匀，然后通过

准直透镜组 3 准直后照射到灰度编码光栅板 4 上, 经过灰度编码光栅板 4 透射后的光线携带有灰度编码光栅信息, 该光线再由光学偏转器 5 进行偏转后, 由于波长 (颜色) 不同, 偏移的距离不同, 因此最终通过第一反射镜 71 和窗口 9 后投影在口腔内表面的灰度编码条纹图像的位置会发生偏移, 从而形成了满足三步相移测量轮廓术所需要的三帧具有不同相移的条纹图像。然后采用摄像头 8 和第二至第五平面反射镜对口腔内表面的参考平面或者是被测物体表面的条纹分布进行成像和记录。其中由于第二平面反射镜 72 与第三平面反射镜 73 这两个平面反射镜的反射表面相对平行放置, 通过多次反射确保在一个较小的空间内能够将窗口 9 外的被测物体的像进行传输, 然后再通过另外两个平面反射镜将图像传送到摄像头 8。摄像系统记录得到的条纹图像通过电路传送至计算机系统 10, 计算机系统 10 根据采集到的条纹图像进行口腔内表面形貌的实时重建。此外, 计算机系统 10 还通过同步电路控制系统控制多色 LED 光源 1 的频闪频率和摄像头 8 的采集频率, 保证二者同步进行。采集完成以后, 计算机系统 10 首先对三帧相移条纹图像进行处理提取其相位信息。其方案如下: 首先对记录下来的三幅条纹图像按照三步相移测量轮廓术的公式计算其截断相位分布; 然后再根据灰度编码信息确定该条纹的级次, 对截断相位进行展开; 最后根据得到的展开相位图像进行重建得到其三维面形数据。

[0025] 应当理解, 图 1 中的第四反射镜和第五反射镜可根据实际情况选用, 只要保证经过第四反射镜 74 和 / 或第五反射镜 75 改变光路后, 带有条纹调制信息的被测物体的像能够最终被摄像头 8 捕获即可, 具体可只选用第四反射镜 74 和第五反射镜 75 中的一个或两个都选用。当然, 若摄像头 8 相对于第二反射镜 72 和第三反射镜 73 的位置合适, 也可省略第四反射镜 74 和第五反射镜 75。

[0026] 上述的数字印模口内扫描仪可以做成一探测头的形状, 平行放置的第二反射镜 72 和第三反射镜 73 间隔小于 16 毫米, 通过多次反射延长光路, 确保在伸入口腔内部的探测器前端部分的外观尺寸小于 20x20 毫米。与其它技术方案相比, 本发明实施例自行设计了一种投影和成像系统, 在保证投影和采集图像高分辨率的情况下将数字印模口内扫描仪 (探测头) 做得更加小巧, 从而适合实现口内操作。

[0027] 本发明实施例提供的数字印模口内扫描仪能够实现直接在人体口腔内部进行扫描, 实时获取牙体和软组织三维面形的新型数字印模, 可以满足口腔科医生和口腔技师快速、准确获取口腔印模的要求。

[0028] 以上所述仅为本发明的较佳实施例而已, 并不用以限制本发明, 凡在本发明的精神和原则之内所作的任何修改, 等同替换和改进等, 均应包含在本发明的保护范围之内。



图 1



Espacenet

Bibliographic data: CN102112845 (A) — 2011-06-29

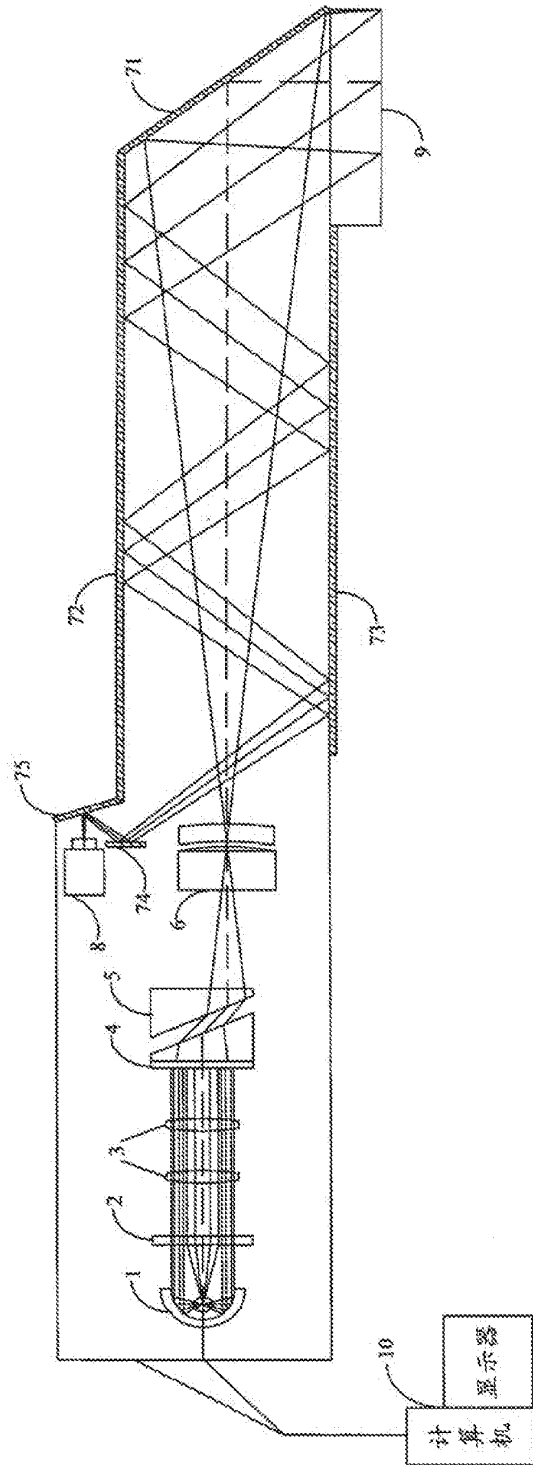
System for adaptive three-dimensional scanning of surface characteristics

Inventor(s): ERIC SAINT-PIERRE; DRAGAN TUBIC; PATRICK HEBERT ±
(SAINT-PIERRE ERIC, ; TUBIC DRAGAN, ; HEBERT PATRICK)

Applicant(s): CREAFORM INC ± (CREAFORM INC)

Classification: - international: G01B11/245; G01B11/25
- cooperative: G01B11/03; G01B11/25; G01B11/30; G06T7/0057

Application number: CN20098129832 20090730

Priority number (s): WO2009CA01105 20090730 ; US20080086554P 20080806

Also published as: CN102112845 (B) WO2010015086 (A1) US2011134225 (A1)
US8284240 (B2) JP2011530071 (A) more

Abstract of CN102112845 (A)

There are provided systems and methods for obtaining a three-dimensional surface geometric characteristic and/or texture characteristic of an object. A pattern is projected on a surface of said object; a basic 2D image of said object is acquired; a characteristic 2D image of said object is acquired; 2D surface points are extracted from said basic 2D image, from a reflection of said projected pattern on said object; a set of 3D surface points is calculated in a sensor coordinate system using said 2D surface points; and a set of 2D surface geometric/texture characteristics is extracted.

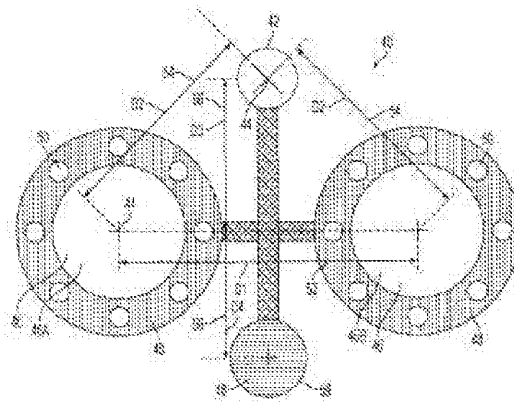
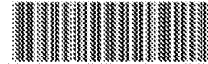

FIG. 1



(12)发明专利申请

(10)申请公布号 CN 102112845 A

(43)申请公布日 2011.06.29

(21)申请号 200980129832.0

(51) Int. Cl.

(22)申请日 2009.07.30

G01B 11/25(2006.01)

(30)优先权数据

G01B 11/245(2006.01)

61/086,554 2008.08.06 US

(85)PCT申请进入国家阶段日

2011.01.28

(86)PCT申请的申请数据

PCT/CA2009/001165 2009.07.30

(87)PCT申请的公布数据

WO2010/015086 EN 2010.02.11

(71)申请人 形创有限公司

地址 加拿大魁北克

(72)发明人 埃里克·圣-皮埃尔

德拉甘·图比克 帕特里克·赫伯特

(74)专利代理机构 北京邦信阳专利商标代理有

限公司 11012

代理人 王昭林 何可

权利要求书 3 页 说明书 15 页 附图 5 页
按照条约第19条修改的权利要求书 3 页

(54)发明名称

用于表面特征自适应性三维扫描的系统

(57)摘要

在此提供了多种系统和方法,用于获取一个物体的三维表面的几何结构特征和/或纹理特征。一个图案被投影到所述物体的一个表面上,获得所述物体的一个基础2D图像;获得所述物体的一个特征2D图像;从所述基础2D图像、从所述投影的图案在所述物体上的反射中提取多个2D表面点;在一个传感器坐标系中使用所述2D表面点来计算多个3D表面点的一个集合;并且提取2D表面几何/纹理特征的一个集合。

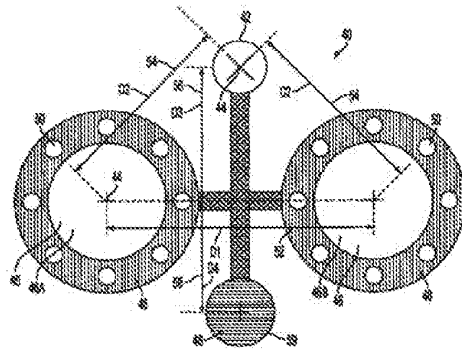

1. 一种用于获取代表物体的多个表面点的数据的系统,所述系统包括:

一个传感装置,该传感装置具有:一个图案投影器,该图案投影器用于在所述物体的一个表面上提供一个投影的图案;至少一个基础照相机,该至少一个基础照相机用于获取代表所述物体的至少一部分的一个基础的 2D 图像的数据;以及一个特征照相机,该特征照相机用于获取代表所述物体的至少一部分的一个特征图像的数据;所述投影的图案在所述基础图像上是清晰的,在一个传感器坐标系中所述基础照相机、所述图案投影器以及所述特征照相机的一种空间关系是已知的;

一个基础图像处理器,该基础图像处理器用于从所述基础 2D 图像数据中提取数据,这些数据代表由所述投影的图案在所述表面上的一个反射所提供的多个 2D 表面点的至少一个集合;

一个 3D 表面点计算器,该 3D 表面点计算器用于在所述传感器坐标系中使用所述代表该 2D 表面点集合的数据来计算多个 3D 表面点的一个集合;

一个特征图像处理器,该特征图像处理器用于将所述 3D 表面点集合在数学意义上投影到所述特征图像数据上以便获得所述 3D 表面点在所述特征图像数据中的一个位置,并且还用于在所述特征图像数据中在离所述投影的 3D 表面点一个短的距离处为所述 3D 表面点集合提取特征数据。

2. 如权利要求 1 所述的系统,进一步包括:

一个用于获得多个变换参数的定位系统,所述变换参数代表在所述传感器坐标系与一个全局坐标系之间的一种空间关系;以及

一个 3D 表面点转换器,该 3D 表面点转换器用于在所述全局坐标系中使用所述转换参数将所述 3D 表面点集合转换成多个被转换的 3D 表面点的一个集合。

3. 如权利要求 2 所述的系统,其中该定位系统包括:

在所述物体上多个目标定位特征的一个集合,所述目标定位特征中的每一个都提供在所述物体上的一个固定位置处;一个使用所述目标定位特征来定义的全局坐标系;所述目标定位特征集合的至少一部分在所述基础 2D 图像上是清晰的,所述目标定位特征集合有待由所述图像处理器从所述基础 2D 图像中提取;并且

其中所述系统进一步包括:

一个 3D 定位计算器,该 3D 定位计算器用于使用所述定位系统来计算所述变换参数。

4. 如权利要求 3 所述的系统,进一步包括:

一个表面重构器,该表面重构器用于积累该被变换的 3D 表面点集合以及用于所述 3D 表面点的所述特征数据,以便提供所述物体的一个 3D 表面模型。

5. 如权利要求 4 所述的系统,其中所述表面重构器包括一个模型分辨率调整器,该模型分辨率调整器用于调整所述积累该被变换的 3D 表面点集合的一个分辨率。

6. 如权利要求 4 和 5 中任何一项所述的系统,进一步包括:

一个局部切面计算器,该局部切面计算器用于在该全局坐标系中从该被变换的 3D 表面点集合计算多个局部切面的一个集合,

所述表面重构器使用所述局部切面来提供所述物体的所述 3D 表面模型。

7. 如权利要求 6 所述的系统,其中所述局部切面计算器包括一个切面分辨率调整器,该切面分辨率调整器用于调整所述计算多个局部切面的一个集合的一个分辨率。

8. 如权利要求 1 至 5 中任何一项所述的系统, 其中所述特征照相机是一种纹理照相机, 所述特征图像是一种纹理图像, 其中所述特征图像处理器包括一个纹理图像处理器, 并且其中所述特征数据是在多个纹理图块中获得的纹理数据。

9. 如权利要求 6 至 7 中任何一项所述的系统, 其中所述特征照相机是一种纹理照相机, 所述特征图像是一种纹理图像, 其中所述特征图像处理器包括一个纹理图像处理器, 并且其中所述特征数据是在多个图像纹理图块中获得的纹理数据。

10. 如权利要求 9 所述的系统, 进一步包括:

一个纹理整合器, 该纹理整合器用于将该多个纹理图块的集合映射并累加到该多个局部切面的集合上, 以便产生以下各项之一: 多个 2D 纹理贴图的一个集合以及多个局部的纹理化切面的一个集合。

11. 如权利要求 1 至 10 中任何一项所述的系统, 其中所述特征照相机是一种高分辨率照相机, 所述特征图像是一种高分辨率 2D 图像, 其中所述特征图像处理器包括一个高分辨率图像处理器, 并且其中所述特征数据是多个高分辨率的 2D 表面点。

12. 如权利要求 1 至 11 中任何一项所述的系统, 其中所述特征照相机是一种高分辨率纹理照相机, 所述特征图像是一种高分辨率纹理图像, 其中所述特征图像处理器包括一个纹理图像处理器以及一个高分辨率图像处理器, 并且其中所述特征数据包括多个高分辨率的 2D 表面点以及在多个图像纹理图块中获得的纹理数据。

13. 一种用于获取代表物体的多个表面点的数据的方法, 所述方法包括:

使用至少一个基础照相机来获取代表所述物体的至少一部分的一个基础 2D 图像的数据, 在所述基础图像上一个投影的图案是清晰的;

使用一个特征照相机来获取代表所述物体的至少一部分的一个特征图像的数据;

从所述基础 2D 图像数据中提取数据, 这些数据代表由所述投影的图案在所述表面上一个反射所提供的多个 2D 表面点的至少一个集合;

使用所述代表 2D 表面点集合的数据在所述传感器坐标系中计算多个 3D 表面点的一个集合; 并且

将所述 3D 表面点的集合在数学意义上投影到所述特征图像数据上, 以便获得所述 3D 表面点在所述特征图像数据中的一个位置;

在所述特征图像数据中在离所述投影的 3D 表面点一个短的距离处为所述 3D 表面点集合提取特征数据。

14. 如权利要求 13 所述的方法, 其中所述基础 2D 图像以及所述特征图像是使用一个传感装置获得的, 该传感装置具有: 一个图案投影器, 该图案投影器用于在所述物体的所述表面上提供所述投影的图案; 用于获取所述物体的一个基础 2D 图像的至少一个基础照相机; 以及用于获取所述物体的一个特征图像的一个特征照相机; 在一个传感器坐标系中所述基础照相机、所述图案投影器以及所述特征照相机的一种空间关系是已知的。

15. 如权利要求 13 和 14 中任何一项所述的方法, 进一步包括:

获得多个变换参数, 所述变换参数代表在所述传感器坐标系与一个全局坐标系之间的一种空间关系;

在所述全局坐标系中使用所述变换参数将所述 3D 表面点集合转换成多个被转换的 3D 表面点的一个集合。

16. 如权利要求 15 所述的方法,进一步包括:
积累该变换的 3D 表面点的集合以便提供所述物体的一个 3D 表面模型。
17. 如权利要求 16 所述的方法,进一步包括:
在该全局坐标系中从该变换的 3D 表面点集合计算多个局部切面的一个集合,
使用所述局部切面来提供所述物体的所述 3D 表面模型。

用于表面特征自适应性三维扫描的系统

[0001] 相关申请的交叉引用

[0002] 本申请要求于 2008 年 8 月 6 日由本申请人提交的美国临时专利申请号 61/086,554 的优先权,该申请的说明书通过引用结合在此。

技术领域

[0003] 本说明总体上涉及物体的表面几何结构的三维扫描领域。

背景技术

[0004] 为了建立一个物体表面的几何模型,已经开发了多种距离传感器。这些传感器在多个点的一个集合处测量传感器与表面之间的距离。对于近距离测量,典型地是使用基于三角测量的激光距离传感器。然后,一个物体的部分或整个表面形状可以从收集自多个视点的测量值进行建模。为此目的,应该在将这些距离测量值整合进入一个公共的全局坐标系之前确定在传感器与物体之间的相对位置。人们可以使用一个外部定位装置或者可以在传感装置之中整合自动对位功能。例如 P. Hébert 等人在编号 WO 2006/094409A1 下公开的国际专利申请中说明了一种自动对位的手持式距离传感器,该传感器整合了一种激光图案投影器以及两个照相机,这两个照相机同时捕捉激光图案的图像以及后向反射的目标特征的图案。这些后向反射的特征被用于自动对位并且使用 LED 将其照明,这些 LED 的谱带与该激光图案投影器的谱带相匹配。基于对这些特征的观察,该系统将激光三角测量与用于自动对位的摄影测量法的原理结合在一起。对于手持式的操作而言该系统是紧凑的,并且该系统增量地并且同时建立了这些目标特征的 3D 位置的一个模型用于在重构该表面的几何结构的同时匹配和计算该距离传感器的当前位置。

[0005] 使用这样一种系统不允许捕捉该物体表面的颜色纹理。人们可以首先建立该物体表面的 3D 模型,并且然后使用一个彩色照相机来收集该物体表面的图像,在将这些图像合并以及整合进入一种纹理化的模型表示之前,它们可以与该模型对齐。然而,这样一种方法将要求两个系统,而在扫描的同时并未提供一种增量地建立完整模型的能力。

[0006] 已知系统的另一个限制是与复原的模型的分辨率相关的。由于这些照相机被用于定位,所以要求宽广的视野。相反,为了复原一个物体表面形状(即其几何结构)的较高分辨率,应该将一个更小的表面区域映射到这些图像中的更大数量的像素上。因此,在定位与该几何结构的复原分辨率之间存在着一种妥协。

发明内容

[0007] 在此提供了多种系统和方法,它们允许用一个可操纵的激光距离传感器增量地捕获一个物体的表面纹理和几何结构这两者的特征。而且,这些系统和方法进一步允许在保留自动对位能力的同时在高分辨率下捕获这类特征。

[0008] 为了在提供彩色图像的自动对准的同时使之有可能同时捕获一个物体的表面纹理以及几何结构,人们可能考虑用彩色照相机替代现有技术中所说明的系统中的这些照相

机。人们将会面对许多困难,包括用白光照明替换由 LED 进行的可见彩色照明(典型地是红色照明,这些 LED 的谱带与该激光图案投影器的谱带相匹配),在扫描的同时表面高光的最小化,以及在纹理必须被复原处的激光单色光的附近区域之间的干涉。此外,人们应当开发一种增量方法用于在扫描的同时将纹理整合进入表面模型之中。即使在提出用于解决这些问题的一种新系统及多种方法之后,由于之前提及的在定位与测量特征的分辨率之间的妥协,纹理和几何结构特征的分辨率仍然将是受限的。

[0009] 在此提供了多种系统和方法用于获取一个物体的三维表面的几何结构特征和/或纹理特征。一个图案被投影到所述物体的一个表面上,获得所述物体的一个基础 2D 图像;获得所述物体的一个特征 2D 图像;从所述基础 2D 图像、从所述投影的图案在所述物体上的一个反射中提取多个 2D 表面点;在一个传感器坐标系中使用所述 2D 表面点来计算多个 3D 表面点的一个集合;并且提取 2D 表面几何/纹理特征的一个集合。

[0010] 根据本发明的一个广义的方面,在此提供了一种用于获取代表物体多个表面点的数据的系统。该系统包括一种传感装置,该传感装置具有:一个图案投影器,用于在该物体的一个表面上提供一个投影的图案;至少一个基础照相机,用于获得代表该物体的至少一部分的一个基础 2D 图像的数据;以及一个特征照相机,用于获得代表该物体的至少一部分的一个特征图像的数据;该投影的图案在该基础图像上是清晰的,在一个传感器坐标系中该基础照相机、该图案投影器以及该特征照相机的一种空间关系是已知的;一个基础图像处理器,该基础图像处理器用于从该基础 2D 图像数据提取数据,这些数据代表由该投影的图案在该表面上的一个反射所提供的多个 2D 表面点的至少一个集合;一个 3D 表面点计算器,该 3D 表面点计算器用于在该传感器坐标系中使用代表 2D 表面点集合的数据来计算多个 3D 表面点的一个集合;一个特征图像处理器,该特征图像处理器用于在数学意义上地将该 3D 表面点集合投影到该特征图像数据上以便获取这些 3D 表面点在该特征图像数据中的一个位置、并且用于在该特征图像数据中在离这些投影的 3D 表面点一个短距离处为该 3D 表面点集合提取特征数据。

[0011] 在一个实施方案中,该特征照相机是一种纹理照相机,该特征图像是一种纹理图像,该特征图像处理器包括一个纹理图像处理器,并且该特征数据是在多个纹理图块中获得的纹理数据。

[0012] 在一个实施方案中,该特征照相机是一种高分辨率照相机,该特征图像是一种高分辨率 2D 图像,该特征图像处理器包括一个高分辨率图像处理器,并且该特征数据是多个高分辨率的 2D 表面点。

[0013] 根据本发明的另一个广义的方面,在此提供了一种用于获取代表物体多个表面点的数据的方法。该方法包括:使用至少一个基础照相机来获取代表该物体的至少一部分的一个基础 2D 图像的数据,一个投影的图案在该基础图像上是清晰的;使用一个特征照相机来获取代表该物体的至少一部分的一个特征图像的数据;从该基础 2D 图像数据中提取代表由该投影的图案在该表面上的一个反射所提供的多个 2D 表面点的至少一个集合的数据;使用该代表 2D 坐标系表面点集合的数据在该传感器坐标系中计算多个 3D 表面点的一个集合;并且在数学意义上将该 3D 表面点集合投影到该特征图像数据上,以便获得这些 3D 表面点在这些特征图像数据中的一个位置;在这些特征图像数据中在离这些投影的 3D 表面点一个短距离处为该 3D 表面点集合提取特征数据。

[0014] 在一个实施方案中,该基础 2D 图像以及该特征图像是使用一种传感装置获得的,该传感装置具有:一个图案投影器,用于在该物体的表面上提供该投影的图案;至少一个基础照相机,用于获取该物体的一个基础 2D 图像;以及一个特征照相机,用于获取该物体的一个特征图像;在一个传感器坐标系中该基础照相机、该图案投影器以及该特征照相机的一种空间关系是已知的。

[0015] 根据另一个方面,在此提供了使用一个额外的彩色照相机的系统和方法,该彩色照相机具有一个更高焦距的透镜以便捕获一个特征图像,连同与该距离传感器的一种紧密连接。由该距离传感器捕获的用于低分辨率几何结构测量的基础图像被用于引导该特征图像中的表面纹理的提取。该额外的照相机也可以是单色的(即灰度)并且可以被用于捕获该物体上的高分辨率的几何结构。类似地,将多个基础图像用于引导该高分辨率特征的提取。更广义地讲,当在高分辨率下捕获这两种特征时,在对该物体的表面建模的同时可以对几何结构和颜色纹理分辨率两者独立地进行适配。

[0016] 根据另一个方面,在此提供了一种用于获得一个物体的多个三维表面点的系统。该系统包括一个传感装置,该传感装置具有:一个图案投影器,用于在所述物体的一个表面上提供一个投影的图案;至少一个基础照相机,用于获取在所述物体上的一个基础 2D 图像;以及一个特征照相机,用于获取在所述物体上的一个高分辨率 2D 图像。该投影的图案在所述基础图像上是清晰的,并且在所述基础照相机与所述图案投影器之间的一种对位(reference)、以及在所述基础照相机与所述特征照相机之间的一种对位是已知的。该系统进一步包括一个图像处理器、一个 3D 表面点计算器以及一个高分辨率图像处理器。该图像处理器从所述基础 2D 图像中提取由所述投影的图案在所述表面上的一个反射所提供的多个 2D 表面点的至少一个集合。该 3D 表面点计算器在一个传感器坐标系中使用所述 2D 表面点集合来计算多个 3D 表面点的一个集合。该高分辨率图像处理器将所述 3D 表面点集合投影到所述高分辨率 2D 图像上,以便从该高分辨率 2D 图像计算多个 2D 高分辨率表面点的至少一个集合。

[0017] 根据另一个方面,在此提供了一种用于获得物体的多个三维表面点以及一种纹理的系统。该系统包括一个传感装置,该传感装置具有:一个图案投影器,用于在所述物体的一个表面上提供一个投影的图案;至少一个基础照相机,用于获取在所述物体上的一个基础 2D 图像;以及一个特征照相机,用于获取在所述物体上的一个纹理图像。该投影的图案在所述基础图像上是清晰的,并且在所述基础照相机与所述图案投影器之间的一种对位、以及在所述基础照相机与所述特征照相机之间的一种对位是已知的。该系统进一步包括一个图像处理器、一个 3D 表面点计算器以及一个纹理图像处理器。该图像处理器从所述基础 2D 图像中提取由所述投影的图案在所述表面上的一个反射所提供的多个 2D 表面点的至少一个集合。该 3D 表面点计算器在一个传感器坐标系中使用所述 2D 表面点集合的数据来计算多个计算的 3D 表面点的一个集合。该纹理图像处理器将所述 3D 表面点集合投影到所述纹理图像上,以便从该纹理图像计算多个纹理图块的至少一个集合。

[0018] 根据另一个方面,在此提供了一种用于获得一个物体的多个三维表面点的系统。该系统包括一个传感装置,该传感装置具有:一个图案投影器,用于在所述物体的一个表面上提供一个投影的图案;至少一个基础照相机,用于获取在所述物体上的一个基础 2D 图像;以及一个特征照相机,用于以高分辨率获取在所述物体上的一个特征 2D 图像。该投影

的图案在所述基础图像上是清晰的,并且在所述基础照相机与所述图案投影器之间的一种对位,以及在所述基础照相机与所述特征照相机之间的一种对位是已知的。该系统进一步包括:一个基础图像处理器,用于从所述基础 2D 图像提取由所述投影的图案在所述表面上的一个反射提供的多个 2D 表面点至少一个集合;一个 3D 表面点计算器,用于在一个传感器坐标系中使用所述 2D 表面点集合计算多个 3D 表面点的一个集合;一个高分辨率图像处理器,用于将所述 3D 表面点集合投影到所述特征 2D 图像上,以便获得投影的表面点的一个集合并且从该特征 2D 图像计算多个 2D 高分辨率表面点的至少一个集合;一个纹理图像处理器,用于从该特征 2D 图像并且使用该投影的表面点集合来计算多个纹理图块的至少一个集合;一个 3D 定位计算器,用于计算多个变换参数,这些变换参数指示在所述传感器坐标系与所述全局坐标系之间的一种关系,用于在所述全局参考帧中与所述传感装置的一个位置对位;一个 3D 表面点变换器,用于使用所述变换参数将在该传感器坐标系中的所述 3D 表面点集合变换到在所述全局参考帧中的多个变换的 3D 表面点的一个集合;一个局部切面计算器,用于从在该全局参考帧中的变换的 3D 表面点集合计算多个局部切面的一个集合;一个纹理整合器,用于将该纹理图块集合映射并且累加到该局部切面集合上,以便产生多个局部纹理化的切面的一个集合;以及一个表面重构器,该表面重构器用于积累该变换的 3D 表面点集合,以便提供所述物体的一个 3D 表面模型,并且还用于将该局部纹理化的切面集合映射到该 3D 表面模型上。

[0019] 根据另一个方面,在此提供了一种用于获得一个物体的多个三维表面点的方法。在所述物体的一个表面上提供一个投影的图案,获得所述物体的一个基础 2D 图像。该投影的图案在所述图像上是清晰的,并且在所述基础 2D 图像与所述投影的图案之间的一种对位是已知的。获得所述物体的一个高分辨率 2D 图像。在所述基础 2D 图像与所述高分辨率 2D 图像之间的一种对位是已知的。从所述基础 2D 图像数据中,从所述投影的图案在所述表面上的一个反射中提取多个 2D 表面点的至少一个集合。在一个传感器坐标系中使用所述 2D 表面点集合计算多个 3D 表面点的一个集合。将该 3D 表面点集合投影到所述高分辨率 2D 图像上,以便从该高分辨率 2D 图像计算多个 2D 高分辨率表面点的至少一个集合。

[0020] 根据另一个方面,在此提供了一种用于获得物体的多个三维表面点以及一种纹理的方法。在所述物体的一个表面上提供一个投影的图案,获得所述物体的一个基础 2D 图像。该投影的图案在所述图像上是清晰的,并且在所述基础 2D 图像与所述投影的图案之间的一种对位是已知的。获得所述物体的一个纹理 2D 图像。在所述基础 2D 图像与所述纹理 2D 图像之间的一种对位是已知的。从所述基础 2D 图像数据中,从所述投影的图案在所述表面上的一个反射中提取多个 2D 表面点的至少一个集合。在一个传感器坐标系中使用所述 2D 表面点集合计算多个 3D 表面点的一个集合。将该 3D 表面点的集合投影到所述纹理 2D 图像上,以便从该纹理图像计算多个 2D 纹理图块的至少一个集合。

附图说明

[0021] 图 1 描绘了一种用于三维表面扫描的装置的构型;

[0022] 图 2 展示了在使用中的图 1 中所描绘装置的一种构型以及在采集过程有待测量的物体;

[0023] 图 3 是一个框图,展示了一种用于三维表面扫描的系统;

[0024] 图 4 展示了在一个物体的表面上的多个区域,其中纹理是在激光轨迹附近提取的;

[0025] 图 5 展示了高分辨率激光轨迹在该特征图像中受引导的提取的细节;并且

[0026] 图 6 示出了一个带有外壳的示例性手持式传感器装置。

[0027] 应注意,在所有附图中类似的特征都由类似的参考号标识的。

具体实施方式

[0028] 在说明了图 1 和图 2 中所适配的装置的一种构型之后,从图 3 中展示的框图对整个系统进行说明。

[0029] 图 1 展示了用在图 3 的系统中的传感装置 40 的一个示例性实施方案的示意性正视图。该装置 40 包括两个基础物镜和多个光检测器,在此被称为基础照相机 46。在这个实施方案中,基础照相机 46 是渐进扫描数字照相机。如本领域中的普通技术人员将容易理解的,除了这类照相机以外多种多样的物镜和光检测装置都是适合用于实施本发明的,并且毫无疑问今后将会有其他的装置被开发出来。这两个基础照相机 46 使它们的投影中心分离一个距离 $D1$ 52(即基线)并且组成一个被动式立体的照相机对。这些基础照相机 46 的视野可以是例如 60 度,并且它们可以是单色照相机。

[0030] 一个激光图案投影器 42 典型地定位在离开该立体对的基线的一个距离 $D3$ 56 处,以便组成一个紧凑的三角形构型的结构,产生了两个额外的主动传感器,在第一种情况下它们由左侧照相机以及激光图案投影器组成,并且在第二种情况下由右侧照相机以及激光图案投影器组成。对于这两个额外的主动立体对,在图 1 中描绘了基线 $D2$ 54。激光图案投影器 42 可以是对肉眼安全的 II 级激光。它可以投影一个红色的十字准线图案。激光图案投影器 42 的扇形角可以是 45 度。

[0031] 在图 1 的构型中,该传感装置进一步包括光源 50。该光源可以由分布在基础照相机 46 周围的两组 LED 构成。在这个实施方案中,尽可能靠近照相机 46 的光学轴线来定位光源 50,以便从多个后向反射目标捕获更强的信号。典型地,光源 50 被提供为围绕基础照相机 46 的环形灯。例如,在彩色扫描装置中,可以使用一种包括 8 个白色 LED 的环形灯。在高分辨率扫描装置中,可以使用一种包括 4 个红色 LED 的环形灯。光源 50 照亮安置在物体 62 上并且被用作定位特征的多个后向反射目标 60(见图 2)。这些后向反射目标 60 能够以大约 10cm 的间隔安置在该物体上。光源 50 照明可以进一步照亮该物体表面,以便允许观察颜色纹理。

[0032] 一个第二物镜和光检测器(在此被称为特征照相机 59)被添加到该传感装置上,以便获得物体 62 的表面的一种高分辨率的几何结构和/或颜色纹理。在一个实施方案中,该特征照相机 59 具有一个高分辨率的光检测器,该光检测器捕获物体 62 的一个放大的图像,即与由基础照相机 46 所获得的图像相比是放大的。这个高分辨率特征照相机 59 可以具有 13 度的视野并且可以是单色的。在另一个实施方案中,特征照相机 59 具有一个彩色照相机,该彩色照相机捕获物体 62 的一个颜色纹理图像。这个纹理特征照相机 59 可以具有 20 度的视野并且可以是一种彩色照相机。特征照相机 59 定位在离这两个基础照相机的基线轴线的一段距离 $D4$ 58 处。因此在所有照相机 46、59 以及激光图案投影器 42 之间都存在用于 3D 测量的基线。

[0033] 然而应注意的是,在另外的实施方案中使用了一种单色照相机以获得该物体的灰度纹理图像而不是颜色纹理图像。多个线性偏光过滤器 48 被安装在光源 50 之前以及在特征照相机 59 之前。在光源 50 上以及在特征照相机 59 上的此类过滤器的组合降低或消除了镜反射高光并且保留了漫反射。

[0034] 当 D3 56 是使得该三角形是具有两个 45 度角和一个 90 度角(在十字准线图案 44 的两个激光平面之间)的等腰三角形时,这些基础照相机以及激光图案投影器 42 的三角形构型是特别有意义的。借助这种特别的构型,该十字准线图案是被定向为使得每个平面与每个照相机的投影中心以及与这些图像的中心两者均对齐。这对应于中央核线,其中主要的优点是,一个激光平面(非主动平面)将总是独立于所观察的场景而被成像为在图像中处于相同位置的一条直线。于是可以从两个图像的每个中的变形的第二光平面提取相关的 3D 信息。

[0035] 因此整个基础传感装置包括两个激光轮廓仪 46A-42 以及 46B-42,一个被动立体对 46A-46B,以及用于同时捕获后向反射目标 60 的两个模块 46A-50 以及 46B-50。每个激光轮廓仪 46A-42 和 46B-42 是由基础照相机 46 中的一个与激光图案投影器 42 的组合所限定的。该被动立体对 46A-46B 是由两个基础照相机 46A-46B 的组合所限定的。每个模块 46A-50 和 46B-50 是由基础照相机 46 中的一个及其对应的光源 50 的组合所限定的。这种构型可以是紧凑的。特征照相机 59 增加了三个立体组合(即 59-46A,59-46B 和 59-42)。然而,特征照相机 59 被用于捕获放大的高分辨率几何结构或者颜色纹理图像。这两种特征的测量被整合在所说明的这个实施方案中。

[0036] 对于这个示例性传感装置 40,对于在传感装置 40 与物体 62 之间的 300 到 400mm 的相隔距离处的亚毫米级的准确度而言,基线 D1 52 典型地是大约 190mm。D3 56 的值被设定为 D1 的一半。通过缩放 D1,距离 D2 自动地随之变化。为了紧凑性,距离 D4 58 通常地是小于或等于 D3。对于 D4 的一个典型值是 55mm。

[0037] 要注意的是传感装置 40 典型地是一个手持式装置并且使用位于物体 62 上的多个定位特征来进行自动对位。然而,传感装置 40 没有必要是手持式的并且可以是安装在例如一个机械的致动器上的,并且也可以另外地使用外部对位传感器或者任何其他定位装置进行对位。在传感装置 40 是手持式的情况下,它优选地被制造在一个外壳中,可以容易地用手对该外壳进行操作。因此手持式传感装置 40 的总重量应当考虑到一个典型用户的力量,并且可以被限制到例如 1.5kg。类似地,手持式传感装置 40 的尺寸应当允许在扫描过程中对该传感装置进行操作,并且可以被限制为例如 20cm x 30cm x 25cm。

[0038] 图 2 展示了被定位为以便观察一个有待测量的物体 62 的传感装置 40 的一个 3D 视图。可以看到先前所说明的紧凑的三角形体系结构包括两个基础照相机 46 以及十字准线激光图案投影器 42。传感装置 40 捕获一个图像,该图像包括投影的图案 44 以及一组定位特征 60。定位特征 60 可以由多个孤立的激光点的轨迹或者圆形的后向反射目标组成。在这个实施方案中,该特征照相机 59 捕获了该物体表面的一个放大的图像。

[0039] 图 6 示出了在被适配为由用户手持的外壳中的传感装置 40 的一个实例。外壳 90 包括一个手柄部分 91。基础照相机 46A 和 46B,特征照相机 59 与激光图案投影器 42 的相对位置是如以上所讨论的。手柄部分 91 包括一个触发开关 93 用以启动在环形灯 48 上的灯 50 以及激光图案投影器 42。手持式传感装置 40 使用线路 94 连接到(例如)在一台个

人计算机上提供的采集软件模块上。如将容易理解的,可以由本领域的普通技术人员提供一种无线扫描装置。

[0040] 参见图 3,总体上在 10 处示出了一种适合与传感装置 40 一起使用的 3D 表面扫描系统。除了包括传感装置 40 的整个系统的整合之外,应特别注意到特征图像处理器 15 以及它与 3D 表面点计算器 18 的交互作用 36。由在传感器坐标系中的计算的 3D 低分辨率表面点的多个集合的引导下,特征图像处理器 15 坐标系可以在更高分辨率下提取纹理(在这种情况下即颜色纹理)和/或几何结构两者。还应特别注意到纹理整合器 25,该纹理整合器将在每个特征图像 13 中提取的纹理图块 74(见图 4)映射到在全局坐标系中复原的部分几何结构上。

[0041] 图 3 的 3D 表面扫描系统 10 实现了纹理成像以及高分辨率几何结构图像功能两者。在图 3 的 3D 表面扫描系统 10 中,纹理和几何结构两者是同时获得的。然而,要注意在另一个实施方案中,仅实施了纹理成像并且省略了高分辨率几何结构成像。在又一个实施方案中,仅实施了高分辨率几何结构成像。在后一种情况下,特征照相机 59 典型地是一种非彩色(即灰度)照相机,并且省略了纹理整合器 25。还应注意图 3 的 3D 表面扫描系统典型地具有多种选项,从而允许用户启动和关闭纹理成像以及高分辨率几何结构成像功能。

[0042] 传感装置

[0043] 系统 10 包括一个传感装置 11,如以上参见图 1 和图 2 在此更详细说明的传感装置 40。传感装置 11 收集所观察的情景的一组基础图像 12 并且将其传输到一个图像处理器 14 上。这些图像可以是具有不同视点的两个基础照相机 46(见图 1)收集的,其中这些视点中的每个都具有自己的投影中心。基础图像 12 中包含的相关信息可以由在该物体表面上反射的激光图案 44 的反射造成的,也可以是由定位特征 60 造成的,这些定位特征可以被用于计算传感装置 11 相对于其他的帧捕获的相对位置。由于在一个给定帧中的所有图像是被同时捕获的并且包含定位以及表面测量两者,因此定位与表面测量的同步是隐含的。

[0044] 传感装置 11 还整合了一个额外的照相机,亦即特征照相机 59(见图 1),其目的是用于捕获一种特征图像 13。相对于基础照相机 46 的视点,特征照相机 59 的视点是已知的(即对位的),并且基础照相机 46 以及特征照相机 59 相对彼此都是同步的。典型地,一种特征图像 13 或者是一种高分辨率图像或者是例如一种彩色图像。

[0045] 在图 3 中,传感装置 11 被示出为包括至少一个基础照相机 46 以及至少一个特征照相机 59,这个(这些)基础照相机 46 生成该组基础图像 12 并且特征照相机 59 生成特征图像 13。

[0046] 本领域的普通技术人员应注意到并且容易理解的是,替代从一对照相机完成立体图像,也有可能执行“来自运动的立体图像”或者“来自运动的 3D 图像”并且因此使用一个单一的照相机用于定位。

[0047] 图像处理器

[0048] 图像处理器 14 从每个基础图像 12 提取定位特征和表面点。对于每个基础图像 12,输出了所观察的多个 2D 定位特征的一个集合 20 以及多个 2D 表面点的多个集合 16(包括它们的连接性)。对于这些集合中的每个的连接性事实上定义了多个 2D 曲线区段。在基础图像 12 中对这些表面点和特征基于其固有特征进行识别。与这些特征相关的多个像

素相对于背景是有反差的,并且在使用质心或椭圆拟合来估算它们的位置之前可以用简单的图像处理技术将它们隔离(见 E. Trucco and A. Verri, "Introductory techniques for 3-D computer vision", Prentice Hall, 1998)。使用圆形的目标允许从拟合的椭圆方程式中提取表面法线定向信息,因此协助了传感器定位。从这些定位特征中将表面点的这些集合区别出来,因为该激光图案投影器在这些图像中产生了多个对比的曲线部分并且因此展现了一种不同的 2D 形状。这些图像曲线部分是作为多个单一的团点被分离出的,并且对于这些图案中的每个团点都对该曲线区段进行分析从而用亚像素精确度沿该曲线提取多个点的一个集合。这是通过在该曲线部分上对一个微分算子进行卷积并且将其响应的零交点进行内插而实现的。后者的运算典型地被称为峰值检测。

[0049] 对于一个十字准线激光图案,人们可以从在此说明的装置的体系结构中获益。在这样一种带有两个基础照相机 46 以及一个十字准线图案投影器 42 的配置中,基础照相机 46 被对齐而使得两个激光平面中的一个在每个基础照相机 46 中在一个恒定的位置产生一条单一的直线。这就是对于一个给定的照相机 46 的非活动激光平面。这些非活动激光平面对两个照相机 46 而言都是相反的。由 Hébert 提及的这种构型(见 P. Hébert, "A Self-Referenced Hand-Held Range Sensor", in proc. of the 3rd International Conference on 3D Digital Imaging and Modeling(3DIM 2001), 28 May-1 June 2001, Quebec City, Canada, pp. 5-12) 大大简化了图像处理任务。它还将 2D 表面点的每个集合的分配简化成了该十字准线的一个激光平面连同它们在 3D 中的连接性用于限定多个曲线区段。

[0050] 虽然在这些 2D 表面点集合 16 在该系统中遵循一条路径以便恢复对表面几何结构的整个扫描,这些所观察的 2D 定位特征集合 20 遵循一条第二路径并且被用于恢复传感装置 11 相对于该物体表面的相对位置。然而,这两种类型的集合被进一步处理用于在该传感器坐标系中以及在如以下所说明的全局坐标系中获得 3D 信息。

[0051] 3D 表面点计算器

[0052] 3D 表面点计算器 18 将所提取的 2D 表面点的多个集合 16 作为第一输入。这些点可以是与该激光投影的图案的一个部分相关联的,例如十字准线图案 44 的两个平面之一。当这种关联是已知的时,通过将相应的投影光线与该激光平面的方程式相交,这些 2D 点中的每个都可以被转换成在该传感器坐标系中的一个 3D 点。该光线的方程式是从相关联的照相机的投影矩阵获得的。该激光平面的方程式可以使用一种预校准程序来获得(见 P. Hébert, "A Self-Referenced Hand-Held Range Sensor", in proc. of the 3rd International Conference on 3D Digital Imaging and Modeling(3DIM 2001), 28 May-1 June 2001, Quebec City, Canada, pp. 5-12)。还有可能在使用一种(例如)精确平移台对传感器 11 进行校准之后通过采用表格查找来直接地从一个 2D 点获得一个 3D 点。两种方法都是适当的。在第一种情况下,程序是简单的并且不需要复杂的仪器,但是它要求对这些照相机的固有和非固有参数进行非常好的估算。

[0053] 还有可能避免将每个 2D 点与该激光图案的一种特定的结构相关联。对于更复杂或更通用的图案而言,这是特别有意义的。在这种情况下,仍然有可能使用基本矩阵并且利用核线约束以匹配多个点来计算多个 3D 表面点。当这可以无歧义地完成时,可以从这些照相机的已知的投影矩阵计算出三角测量值以便获得在该传感器坐标系中的一个 3D 点。

[0054] 3D表面点计算器18将在传感器坐标系中的计算的3D低分辨率表面点的这些集合19送到特征图像处理器15中以便如以下所说明由特征图像处理器15协助提取高分辨率的2D点。计算的3D表面点的这些集合被称为具有低分辨率以便将它们传感器坐标系中的输出计算的3D表面点的全体集合21内进行区分,该全体集合包括在传感器坐标系中的3D低分辨率表面点的这些集合19以及在传感器坐标系中的高分辨率表面点的多个集合17。

[0055] 为了计算高分辨率表面点的这些集合,3D表面点计算器18将进一步将高分辨率2D表面点的多个集合17作为输入。使用了与以上在此所说明的用于计算低分辨率3D表面点的相同的程序。这个程序或者要求该特征照相机的固有和非固有参数的非常良好的估算或者要求利用表格查找。

[0056] 3D表面点计算器18输出了在该传感器坐标系中所计算的3D表面点的全体集合21。这些集合可以是无组织的集合或者被组织成使得与在图像中相连的区段相关联的多个3D点被分组以用于通过微分来估算3D曲线的切线。这些区段可以根据其来源图像被进一步分组成分辨率和低分辨率区段。这种信息可以由局部切面计算器29或者表面重构器34加以利用,用于局部地对该复原的表面模型35的质量进行适配。

[0057] 特征图像处理器

[0058] 特征图像处理器15将一个特征图像13作为输入,该特征图像是从特征照相机59(见图1)获得的一个图像,该特征照相机典型地安装了具有更高焦距的一个透镜。典型地,特征图像13仅覆盖该扫描的一小部分(为了更好的分辨率),该部分没有必要包括一个定位特征或者反射在该物体上的整个图案。因此,这种对位从基础图像12中是已知的,并且在特征图像13和基础图像12之间的空间关系从照相机校准中是已知的。特征图像13可以是单色的或者彩色的。虽然在前一种情况下所提取的特征本质上具有几何结构或者单色纹理,但是在后一种情况下该特征进一步包括颜色纹理特征。

[0059] 为了计算高分辨率的几何结构信息(即高分辨率特征2D表面点的多个集合),特征图像处理器15将在传感器坐标系中的3D低分辨率表面点的这些集合19投影到特征照相机59的坐标系中,该照相机的固有参数都是预校准的并且该照相机相对该传感器坐标系的空间关系(即其非固有参数)也已经通过照相机校准而获得。多个相连的3D点的这些投影的集合将多个区段的集合投影到特征图像13之中。从在该特征图像坐标系中这些所获得的近似位置处,将局部图像处理应用于从成像的激光轨迹中提取多个2D对应点。

[0060] 为了做到这一点,从投影产生的多个相连2D点的每个集合都提供了该曲线区段的一个逐段的线性逼近(即一条折线80)。图5展示了在这种特征影像激光轨迹88的引导提取的细节。在所计算的3D低分辨率表面点的对应相连的集合的投影之后,最初从这些基础图像获得的一个逐段线性逼近(即一条折线80)被叠加到特征图像13上。这些点的投影是折线80的多个顶点82。然后对折线80进行重新采样。在图5中,一个部分以采样因子5展示,导致每个线性部分有4个额外的点84。在沿折线80的每个点82和84处,沿法线方向86对该特征图像进行采样。典型地,沿这些方向计算20到30个图像样本,产生一个1D信号。这些样本之间的距离是一个像素的宽度。从这个1D曲线中估算该亚像素峰值位置,因此提供了一个高分辨率的2D表面点。最后,使用这些信号来检测在该特征图像中的激光轨迹88的多个峰值,在低分辨率折线的突出处获得了这些峰值的一个细化的位置。为每个相连的集合收集这些2D表面点致使输出高分辨率2D表面点的多个集合17。

[0061] 应指出,还有可能从该局部特征图像信号来估算该局部法线方向。

[0062] 几何结构是一个物体表面的一种特征。可以独立地进行处理的其他特征是灰度纹理和颜色纹理。应指出,虽然在以下说明中假定为颜色纹理采集和处理,但是灰度纹理的采集和处理也是有可能的。原理保持不变;该局部特征提取是使用在该传感器坐标系中的 3D 低分辨率表面点的多个初始集合的投影来引导的。如果在该折线附近存在一个激光轨迹,那么在接近该激光轨迹两侧处的一个区域中收集这些像素的颜色。图 4 展示了在该特征图像中该激光轨迹附近的复原的纹理图块 74。在该图的右侧部分,一个部分被放大。离开该激光轨迹的两个距离 r_1 72 和 r_2 70 界定了在该激光轨迹附近的所复原纹理的宽度。颜色在一个间隔距离之内被复原,该间隔距离的范围在 r_1 72 和 r_2 70 之间。 r_1 72 被设定为使之避免与该激光发生颜色干扰;在这一个实施方案中对于 r_1 72 典型的值是 10 像素并且对于 r_2 70 是 25 像素。这些合成局部纹理的像素中的每个都被指定了在该复原的曲线区段上或者可替代地在该折线上(当该几何结构没有被细化时)的最近的表面点的坐标 (x, y, z, r, g, b) 。特征图像处理器 15 将多个图像纹理图块的集合作为在该传感器坐标系中使用 3D 坐标扩充的纹理位图进行输出。对于一个给定的帧,该图像纹理图块集合 74 被送到纹理整合器 25 中,该整合器的作用是将所有视点收集的所有图像纹理图块合并。在局部切面计算器之后将对纹理整合器 25 进行说明。3D 定位计算器

[0063] 3D 定位计算器 23 的任务是为每个计算的 3D 表面点集合 21 以及图像纹理图块集合提供变换参数 26。这些变换参数 26 在保留该结构的同时使之有可能将 3D 表面点 21 或者用于图像纹理图块 22 的每个像素的 (x, y, z) 坐标变换入一个单一的全局坐标系中;这种变换是刚性的。在这个实施方案中,这是通过在全局坐标系 30 中建立并且维持参考 3D 定位特征的一个集合来实现的。这些定位特征可以是多个 3D 点的一个集合、带有相关的表面法线的多个 3D 点的一个集合、或者任何其他表面特征。应指出,虽然在这个实施方案中采用了使用定位特征的自动对位,但是在另一个实施方案中可以采用其他的定位系统。例如可以使用外部对位传感器或者其他定位装置。

[0064] 在图 3 的实施方案中,假设所有的定位特征都是 3D 点,这些点表示为包含三个分量的列向量 $[x, y, z]^T$,这些分量指示了这些点沿这三个坐标轴线的位置。

[0065] 由于传感装置 11 是经过校准的,所以在基础照相机 46 的多个视点之间的匹配的定位特征被用于估算它们的 3D 位置。使用该核线约束对所观察的 2D 定位特征的这些集合进行匹配以便获得无歧义的配对。这些核线是使用基本矩阵来计算的,该基本矩阵是从基础照相机 46 的多个校准的投影矩阵计算出的。然后,从照相机 46 的这些已知的投影矩阵,应用三角测量以便为每个帧计算在该传感器坐标系中的多个 3D 定位特征的一个单一的集合。

[0066] 在扫描期间开始时,参考 3D 定位特征的集合 30 是空的。因为传感装置 11 提供测量值的第一集合,使用身份变换将这些特征复制到参考 3D 定位特征集合 30 中。因此这个集合成为所有后续的参考 3D 特征集合的参考集合,并且这个第一传感器位置定义了所有 3D 表面点被对齐到其中的该全局坐标系。

[0067] 在创建参考 3D 定位特征的这个初始集合之后,首先针对参考集合 30 对后续的计算的定位特征集合进行匹配。该匹配操作被分为两个任务:i) 寻找在在用于当前帧的传感器坐标系中计算的 3D 定位特征集合与在该全局坐标系中参考 3D 特征集合之间对应的特

征,并且 11) 计算与这两个集合具有最佳对齐的最优刚性 3D 变换的变换参数 26。一旦已经计算出这些参数,就可以将它们用于变换当前帧的计算的 3D 定位特征、在传感器坐标系中的计算的 3D 表面点 21 以及图像纹理图块 22,因此将它们全部在该全局坐标系中对齐。

[0068] 在计算出参考 3D 定位特征的集合 R 之后,在从照相机 1 和 2 获得的所观察的 2D 定位特征 $20, P_1$ 和 P_2 计算出在当前帧中所计算的 3D 定位特征的集合 O。这些 3D 坐标是通过三角测量获得的。对 3D 定位特征的这些集合进行匹配就是寻找两个子集 $O_n \subseteq O$ 和 $R_n \subseteq R$ 的问题,每个子集包含 N 个特征,这样使得具有 $o_i \in O_n$ 以及 $r_i \in R_n$ 的所有的点对 (o_i, r_i) 代表相同的物理特征。寻找这些子集是通过寻找多个点 (o_i, r_i) 的最大的区段数来实现的,这样使得

[0069] $\|o_i - o_j\| - \|r_i - r_j\| \leq \epsilon$ 对于所有 $i, j \in \{1, \dots, N\}, i \neq j$, (1)

[0070] 其中 ϵ 是一个预定义的阈值,该阈值被设定为对应于该传感装置的准确度。这一约束使得在这两个集合中一个对应的点对之间的距离差是可忽略的。

[0071] 这一匹配运算是作为一种组合的优化问题得到解决的,其中来自集合 O 的每个多点区段是累进地针对集合 R 中的每个多点区段进行匹配的。然后每个匹配的区段通过使用在这两个集合的每个中的剩余的多个点而形成额外的区段而被扩展。如果两个区段满足约束 (1),那么形成一个第三区段,并且只要该约束被满足就如此继续下去。否则就丢弃该对并且检查下一对。其解是满足 (1) 的多个区段的最大集合。其他算法(参见例如 M. Fischler and R. Bolles, (1981) "Random sample consensus: A paradigm for model fitting with applications to image analysis and automated cartography", Communications of the Assoc. for Computing Machinery, (June 1981), vol. 24, no. 6, pp. 381-395.) 可以被用于相同的目的。

[0072] 只要在参考 3D 定位特征集合 30 中的元素数量是相对低的(典型地少于十五个),上述方法的计算复杂度对于实时操作而言就是可接受的。然而在实际中,参考特征的数量可以容易地达到数百个定位特征。由于计算复杂度随特征数量以指数方式增长,这些对应特征的计算可能变得对于实时应用过于缓慢。该问题的解决是通过注意到从任何特定的视点都可见的定位特征数量是少的,该数量是由传感装置 11 的有限的视野所限定的。

[0073] 这意味着如果对于一个给定的帧所计算的特征可以针对参考特征 30 进行匹配,那么来自该参考集合的匹配的特征应该位于一个小的临近区域中,该临近区域的大小是由该计算的特征的集合的大小所决定的。这还意味着在这个临近区域中的点的数量应该也是少的(典型地少于十五个)。为了将这一特征利用于加速匹配,将以上方法修改如下。在匹配之前,为每个参考特征创建多个邻近特征的一个集合 $[N_i]$ 。在初始的多点区段被匹配之后,通过加入一个额外的区段来扩展该初始的多点区段,该额外区段仅使用在第一匹配特征的邻近区域集合 $[N_i]$ 中的点。通过这样做,不管参考集合 30 的大小如何,用于匹配的点的数量保持为低,因此防止了计算复杂度的指数性增长。

[0074] 可替代地,也可以使用传感装置位置与定向的空间相关性来改进匹配速度。通过假定相对于定位特征集合的大小该传感装置的位移是小的,可以通过为每个所观察的定位特征寻找最近的参考特征而实现匹配。相同的原理可以被用在 2D 中,即通过寻找最近的 2D 定位特征。

[0075] 一旦匹配完成,这两个集合就需要通过计算最优变换参数 $[M \ T]$ (在最小二乘法意义上) 来对齐,这样下面的代价函数被最小化:

$$[0076] \quad \sum_{i=1}^N \|r_i - Mo_i + T\|^2 \text{ 对于所有 } i \in \{1, \dots, N\}, \quad (2)$$

[0077] 这些变换参数包括一个 3×3 的旋转矩阵 M 以及一个 3×1 的平移向量 T 。可以使用对偶四元数找到这样一种变换,如在 M.W.Walker, L. Shao and R.A. Volz, "Estimating 3-D location parameters using dual number quaternions", CVGIP:Image Understanding, vol. 54, no. 3, November 1991, pp. 358-367 中所说明的。为了计算这一变换,至少必须找到三个公共的定位特征。否则对于当前帧,定位特征和表面点两者都被丢弃。

[0078] 用于计算这种刚性变换的一种替代方法是将所观察的 2D 定位特征 20 与参考 3D 定位特征 30 的投影之间的距离最小化。使用透视性的投影变换 Π , 该在最小二乘法意义上是最优的刚性变换 $[M \ T]$ 是使下式最小化的变换:

$$[0079] \quad \sum_{i=1}^N \|\Pi M^{-1}(r_i - T) - p_i\| \text{ 对于所有 } i, j \in \{1, \dots, N\}, \quad (3)$$

[0080] 其中 $p_i \in P_1$ 或 $p_i \in P_2$ 是所观察的 2D 特征,它们对应 3D 的所观察的特征 $o_i \in O_o$ 。可以通过使用一种优化算法(如 Levenberg-Marquardt 方法)将上面的代价函数最小化而找到刚性变换 $[M \ T]$ 。

[0081] 一旦该刚性变换被计算出来,该计算的 3D 定位特征集合就从该传感器坐标系变换到该全局坐标系。所变换的 3D 定位特征被用于以两种方式对参考 3D 定位特征的集合 30 进行更新。首先,如果已经针对参考特征集合仅对所观察的特征的一个子集进行了匹配,那么不匹配的所观察的特征代表被添加到该参考集合的新的观察的特征。已经被再观察并且匹配的特征可以或者被丢弃(因为它们已经在参考集合中)或者被用于改进,即过滤这些存在的特征。例如,对同一特征的所有观察可以被加在一起以便计算平均特征位置。通过这样做,测量噪音的变化被减小,因此改进了定位系统的准确度。

[0082] 3D 表面点变换器

[0083] 一旦 3D 定位计算器 23 使得变换参数 26 可供使用,这些对表面点的处理步骤就是简单的。由 3D 表面点计算器 18 提供的在传感器坐标系中的计算的 3D 表面点集合 21 于是由 3D 表面点变换器 24 使用刚性变换参数 26M 和 T 进行变换。因此,所获得的在全局坐标系中的变换的 3D 表面点集合 27 在相同坐标系中与参考 3D 定位特征集合 30 是自然地对齐的。在全局坐标系中的最后的变换的 3D 表面点集合 27 可以被图形化,或者它可以在被送到表面重构器 34 之前被送到局部切面计算器 29 上。该表面重构器将对一个连续的、非冗余的、并且有可能是被过滤的表面模型 35 的表示进行估算,该表示可任选地借助叠加的参考 3D 定位特征集合 30 来显示。

[0084] 局部切面计算器

[0085] 局部切面计算器 29 将全局坐标系中的变换的 3D 表面点集合 27 作为输入,并且在该物体表面上提供对这些 3D 切面的局部估算。尽管这种处理可以被整合在表面重构器 34 之中,但是在此它是分离的以便更好地说明一种连续的表面的表示对跨越一个物体的表面提供多个局部切面估算而言不是必需的。实时获得这些局部切面估算的一种可能性包括:定义一种规则的体积栅格,并且在每个体素之内对这些 3D 表面点进行累加。从

这些 3D 的累加点, 基于位于该体素之内或者位于环绕该体素的一个体积之内的 3D 点可以为每个体素计算一个切面。这类的方法使用在 T. P. Koninckx, P. Peers, P. Dutré, L. J. Van Gool, "Scene-Adapted Structured Light", in *proc. of Computer Vision and Pattern Recognition (CVPR 2005)*, vol. 2, San Diego, USA, 2005, pp. 611-618 中以及 S. Rusinkiewicz, O. A. Hall-Holt, M. Levoy, "Real-time 3D model acquisition" in *proc. of ACM SIGGRAPH 2002*, San Antonio, USA, pp. 438-446 或者在 D. Tubic, P. Hébert, D. Laurendeau, "3D surface modeling from curves", *Image and Vision Computing*, August 2004, vol. 22, no. 9, pp. 719-734 中。

[0086] 一旦这个初始的非连续的几何结构已经局部地稳定, 也就是说, 例如, 一旦该 3D 点协方差矩阵的两个最小的本征值是相似的, 同时该第三本质值在多个体素之内是显著地更低的, 那么就它们的协方差矩阵的两个一阶矩来计算这些局部平面的参数。每个局部切面的跨度典型地是一个直径在 1 个和 2 个体素对角线长度之间的圆。该局部切面计算器输出局部切面的一个集合 28, 该集合包括这些平面的参数、跨度以及从 27 复制的在全局坐标系中的变换的 3D 表面点的集合 31。

[0087] 局部切面计算器 29 可以包括一个切面分辨率调整器用于对计算该局部切面集合的一个分辨率进行调整。该调整器可以是一种手动或者自动的调整器, 调整该调整器允许对用于局部切面计算器 29 的一个分辨率参数进行修改。

[0088] 纹理整合器

[0089] 纹理整合器 25 收集在所有帧中复原的图像纹理图块的集合 22 并且进一步将已经稳定的局部切面集合 28 作为输入。值得提及的是, 这些局部切面当它们变得可供使用时是被独立地送入的。这使之有可能在该表面被扫描时增量地应用该方法; 而没有必要在继续进行之前等待多个帧的完整集合。

[0090] 每个局部切面部分都作为具有一个选定的分辨率的局部图像而进行镶嵌, 该分辨率可以是独立于该几何结构的分辨率而设定的。我们将把这些单元格称为纹素。这个纹理整合器进一步将来自 3D 定位计算器 23 的变换参数 26 作为输入。使用这些变换参数, 在当前传感器坐标系与该全局坐标系之间的空间关系是已知的, 并且因此, 图像纹理图块的集合 22 可以通过回投影被映射到该局部切面上。在纹理图像块集合中的每个像素都对更新其对应的局部切面起作用。为此目的, 从映射到该局部平面上的这些像素对一个局部切面中的所有纹素进行更新。基于一个随距离递减的权重, 每个像素都对所有的纹素都有贡献。纹素是从所有帧中作为所有起作用的像素的加权平均值而获得的。

[0091] 纹理整合器 25 还应用了颜色强度补偿。实际上, 优选的是在将其整合进入纹素之前获取这些稳定的色彩测量值。颜色强度将典型地随相对于光源 50 距离的平方以及光源 50 与该切面法线之间夹角的余弦值而发生变化。在一个实施方案中, 存在八个光源 50, 这些光源分布在这两个基础照相机 46 的中每个的物镜的外围上。此外, 在光源 50 以及特征照相机 59 的前面使用偏光过滤器 48 消除了镜面反射并且保留了漫反射。因此有可能只考虑光源 50 与该表面之间的夹角, 该表面与特征照相机 59 之间的夹角对于颜色强度补偿而言是可以忽略的。这些光源的位置在该传感器坐标系中从该传感器设计中或者从校准中是已知的。另外, 由于每个光源累加地进行组合, 假定这些光源是完全相同的或者通过对它们的亮度进行校准, 可以在多个帧之间将每个纹素上的颜色辐照度归一化。该补偿过程还可

以使用光学测量照相机校准,如在 P. E. Debevec and J. Malik, "Recovering High Dynamic Range Radiance Maps from Photographs", in proc. of ACM SIGGRAPH 1997, Los Angeles, USA, pp. 369-378 中提及的校准。由纹理整合器 25 产生的是局部纹理化的切面的一个集合 32。

[0092] 可替代的,可以通过纹理整合器 25 来准备带有相应的表面坐标映射信息的 2D 纹理贴图 (texture map) 36, 并且这些纹理贴图可以被提供给表面重构器 34。可以使用三角测量数据 37 作为来自表面重构器 24 的一个反馈,以便产生这些 2D 纹理贴图 36。

[0093] 表面重构器

[0094] 表面重构器 3 将一个全局坐标系中的变换的 3D 表面点的集合 31 以及局部纹理化的切面的集合 32 作为输入并且计算一个表面模型。可替代地,可以使用具有相应的表面坐标映射信息的这些 2D 纹理贴图 36。值得注意的是,这些局部切面还可以从该重构的表面获得。从该表面点集合可以使用在美国专利号 US 7,487,063 或者例如在 B. Curless, M. Levoy, "A Volumetric Method for Building Complex Models from Range Images" in proc. of the ACM SIGGRAPH 1996, New Orleans, USA, pp. 303-312 中说明的方法计算出该表面几何结构的一种连续表示。这两种方法采用了一种体积测量表示。前一种方法可以从这些局部切面的知识中获益用于更高的效率。然后该体积测量表示被转换成一种三角化的表面表示。为此目的,可以使用匹配立方体算法 (参见例如 W. E. Lorensen, and H. E. Cline, "Marching Cubes: A High Resolution 3D Surface Construction Algorithm", in proc. of the ACM SIGGRAPH 87, Los Angeles, USA, vol. 21, no. 4, pp. 163-170)。一旦获得了该三角化的表面,局部纹理化的集合就被映射到三角化的表面上,其中它们的重叠区域被混合用于获得一种连续的表面纹理。

[0095] 表面重构器 34 可以包括一个模型分辨率调整器用于对该变换的 3D 表面点集合的积累的分辨率进行调整。该调整器可以是一种手动或者自动的调整器,它允许变更用于表面重构器 34 的一个分辨率参数。

[0096] 当扫描装置 40 被用于纹理扫描时,200 至 250 点每英寸 (DPI) 的位图可以与这些局部切面相关联。能够以 24 位、sRGB 校准的形式提供纹理颜色。该区域的深度可以是例如 30cm。纹理传感装置 40 可以进行 (例如) 每秒大约 18,000 次测量,具有 0.1mm 的几何结构分辨率。

[0097] 当扫描装置 40 被用于高分辨率扫描时,该高分辨率体素分辨率可以是 0.25mm。相比之下,不具有高分辨率能力的扫描装置 40 的体素分辨率可以是 1mm。该区域的深度可以是例如 30cm。高分辨率传感装置 40 可以进行 (例如) 每秒大约 25,000 次测量,在 x, y, z 具有 0.05mm 的分辨率。

[0098] 所说明的不同的装置和部件 (包括例如多个传感器如基础照相机 48、激光投影器 42、以及特征照相机 59) 可以被用于生成可被图 3 中示出的不同处理器所使用的输入数据。

[0099] 虽然在这些框图中被展示为经由不同的数据信号连接彼此通信的多组离散的部件,但是本领域的普通技术人员应理解,这些优选的实施方案可以通过硬件与软件部件的多种组合来提供,其中一些部件是由一个硬件或者软件系统的一个给定的函数或运算实现的,并且所展示的这些数据路径中的许多是由在一个计算机应用程序或者操作系统之中的数据通信来实现的或者可以使用任何适合的已知的或后来开发的有线的和 / 或无线方法

以及装置进行通信地连接。传感器、处理器以及其他装置可以是共同定位的或者是远离与彼此中的一个或多个。因此所展示的结构是为了本发明的优选实施方案的有效传授而提供的。

[0100] 应当理解,对本领域的普通技术人员而言将出现对其多种修改。因此,以上说明及附图应当被认为对本发明是解说性的而非限制的含义。应进一步理解,在此旨在覆盖总体上遵循本发明的原理并且包括对本披露的以下偏离的任何变体、用途、或者适配,这些偏离在本发明所涉及的领域中为人所知或在常规惯例之内,并且可适用于以上给出的本质特征、并且符合所附权利要求的范围。



图 1



图 2

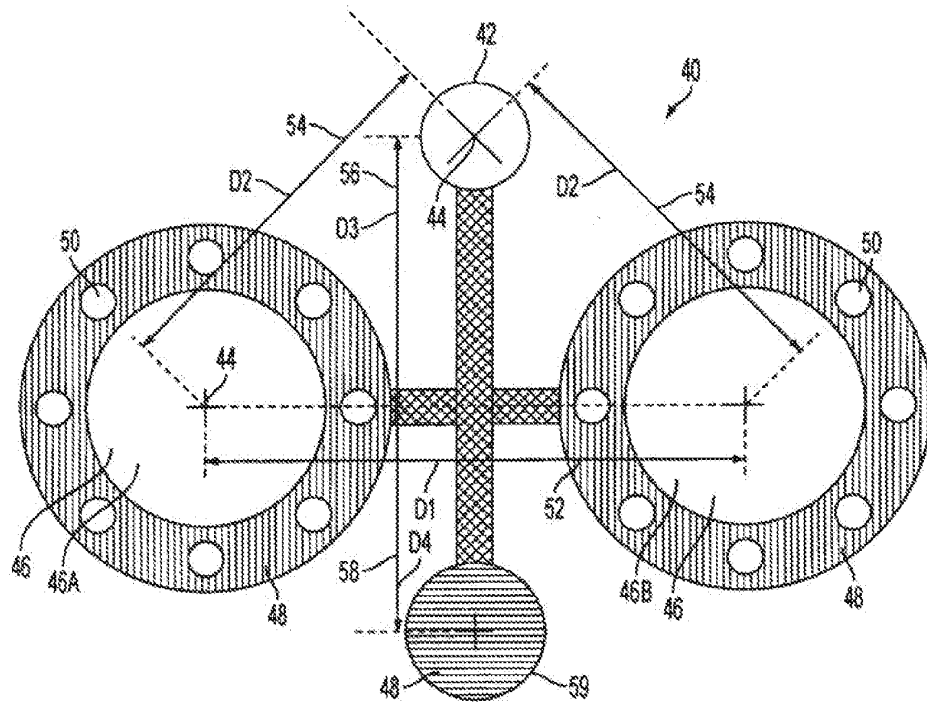

图 4A

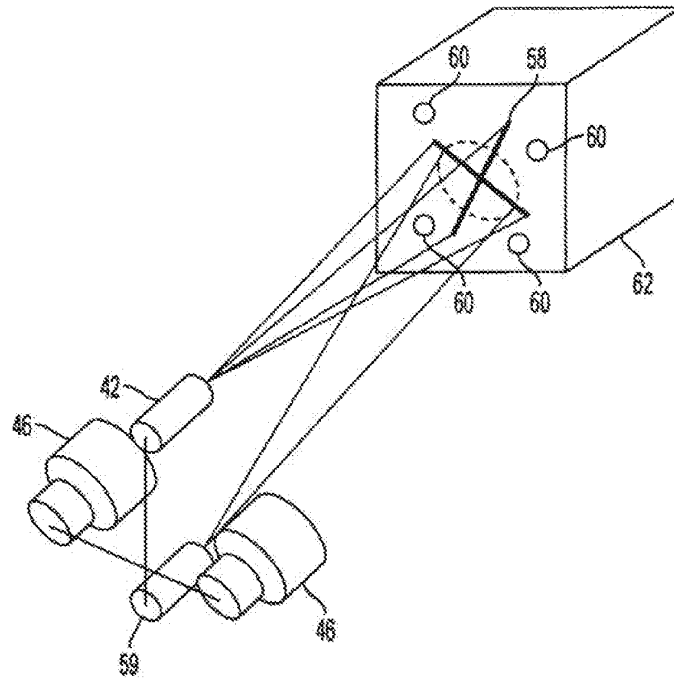

图 4B

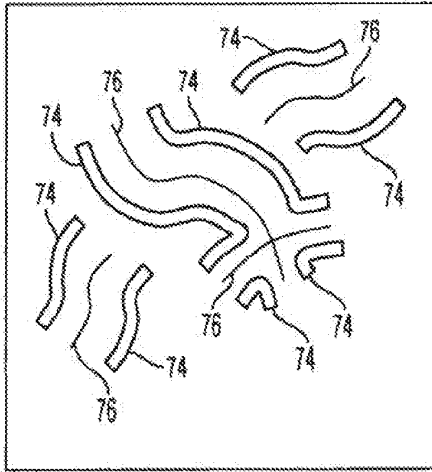

图 5

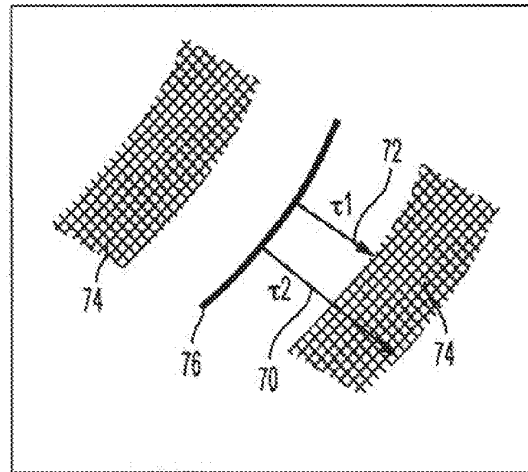

图 6

1. 一种用于获取代表物体的多个表面点的数据的系统,所述系统包括:

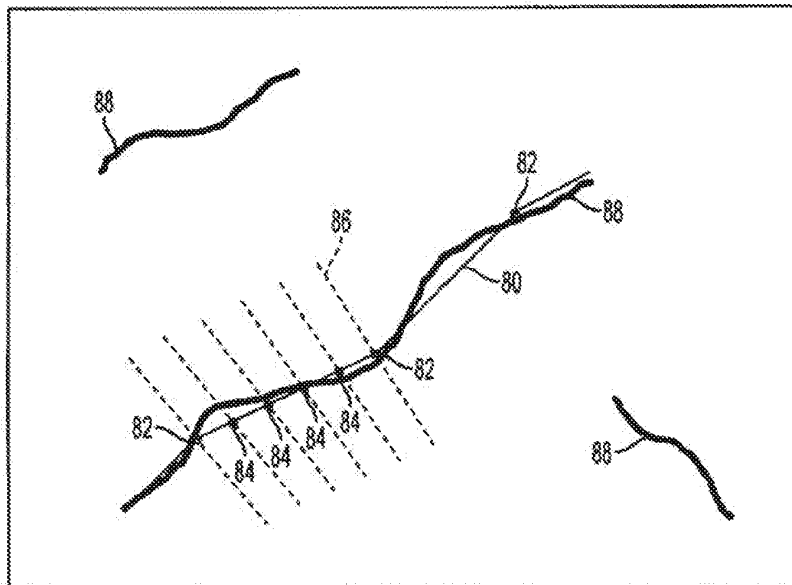
一个传感装置,该传感装置具有:一个图案投影器,该图案投影器用于在所述物体的一个表面上提供一个投影的图案;至少一个基础照相机,该基础照相机用于以一种基础分辨率来获取代表所述物体至少一部分上的一个基础 2D 图像的基础 2D 图像数据;以及一个特征照相机,该特征照相机用于获取代表所述物体的至少一部分的一个特征图像的特征图像数据;所述特征照相机是一个纹理照相机以及一个高分辨率照相机中的至少一个,所述纹理照相机是适配为捕获关于所述物体的所述部分的特征纹理信息的一种照相机,所述高分辨率照相机是适配为在一个高分辨率捕获关于所述物体的所述部分的高分辨率信息的一种照相机,所述高分辨率是高于所述基础分辨率,所述投影的图案在所述基础图像上是清晰的,在一个传感器坐标系中所述基础照相机、所述图案投影器以及所述特征照相机的一种空间关系是已知的;

一个基础图像处理器,该基础图像处理器用于从所述基础 2D 图像数据中提取 2D 点数据,这些 2D 点数据代表由所述投影的图案在所述表面上的一个反射所提供的多个 2D 表面点的至少一个集合;

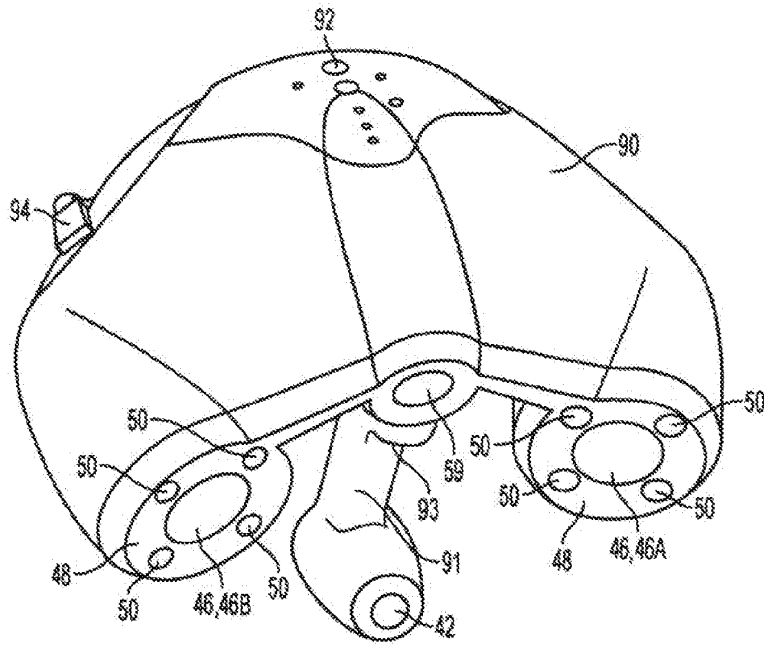
一个 3D 表面点计算器,该 3D 表面点计算器用于在所述传感器坐标系中使用所述代表该 2D 表面点集合的 2D 点数据来计算多个 3D 表面点的一个集合;

一个特征图像处理器,该处理器用于将所述 3D 表面点集合在数学意义上投影到所述特征图像数据上以便获得所述 3D 表面点在所述特征图像数据中的一个位置、并且用于在所述特征图像数据中在离所述投影的 3D 表面点一个短的距离处为所述 3D 表面点集合提取特征数据。

2. 如权利要求 1 所述的系统,进一步包括:

一种用于获得多个变换参数的定位系统,所述变换参数代表在所述传感器坐标系与一个全局坐标系之间的一种空间关系;以及

一个 3D 表面点转换器,该 3D 表面点转换器用于在所述全局坐标系中使用所述转换参数将所述 3D 表面点集合转换成多个被转换的 3D 表面点的一个集合。

3. 如权利要求 2 所述的系统,其中该定位系统包括:

在所述物体上多个目标定位特征的一个集合,所述目标定位特征中的每一个都提供在所述物体上的一个固定位置处;一个使用所述目标定位特征来定义的全局坐标系,所述目标定位特征集合的至少一部分在所述基础 2D 图像上是清晰的,所述目标定位特征集合有待由所述图像处理器从所述基础 2D 图像中提取;并且

其中所述系统进一步包括:

一个 3D 定位计算器,该 3D 定位计算器用于使用所述定位系统来计算所述变换参数。

4. 如权利要求 3 所述的系统,进一步包括:

一个表面重构器,该表面重构器用于积累该被变换的 3D 表面点集合以及用于所述 3D 表面点的所述特征数据,以便提供所述物体的一个 3D 表面模型。

5. 如权利要求 4 所述的系统,其中所述表面重构器包括一个模型分辨率调整器,该模型分辨率调整器用于调整所述积累该被变换的 3D 表面点集合的一个分辨率。

6. 如权利要求 4 和 5 中任何一项所述的系统,进一步包括:

一个局部切面计算器,该局部切面计算器用于在该全局坐标系中从该被变换的 3D 表

面点集合计算多个局部切面的一个集合，

所述表面重构器使用所述局部切面以提供所述物体的所述 3D 表面模型。

7. 如权利要求 6 所述的系统，其中所述局部切面计算器包括一个切面分辨率调整器，该切面分辨率调整器用于调整所述计算多个局部切面的一个集合的一种分辨率。

8. 如权利要求 1 至 5 中任何一项所述的系统，其中所述特征照相机是一种纹理照相机，所述特征图像是一种纹理图像，其中所述特征图像处理器包括一个纹理图像处理器，并且其中所述特征数据是在多个纹理图块中获得的纹理数据。

9. 如权利要求 6 至 7 中任何一项所述的系统，其中所述特征照相机是一种纹理照相机，所述特征图像是一种纹理图像，其中所述特征图像处理器包括一个纹理图像处理器，并且其中所述特征数据是在多个图像纹理图块中获得的纹理数据。

10. 如权利要求 9 所述的系统，进一步包括：

一个纹理整合器，该纹理整合器用于将该纹理图块的集合映射并累加到该多个局部切面的集合上，以便产生以下各项之一：多个 2D 纹理贴图的一个集合以及多个局部的纹理化切面的一个集合。

11. 如权利要求 1 至 10 中任何一项所述的系统，其中所述特征照相机是一种高分辨率照相机，所述特征图像是一种高分辨率 2D 图像，其中所述特征图像处理器包括一个高分辨率图像处理器，并且其中所述特征数据是多个高分辨率的 2D 表面点。

12. 如权利要求 1 至 11 中任何一项所述的系统，其中所述特征照相机是一种高分辨率纹理照相机，所述特征图像是一种高分辨率纹理图像，其中所述特征图像处理器包括一个纹理图像处理器以及一个高分辨率图像处理器，并且其中所述特征数据包括多个高分辨率的 2D 表面点以及在多个图像纹理图块中获得的纹理数据。

13. 一种用于获取代表物体的多个表面点的数据的方法，所述方法包括：

使用至少一个基础照相机在一个基础分辨率上获取代表所述物体的至少一部分的一个基础 2D 图像的基础 2D 图像数据，在所述物体的一个表面上投影的一个投影的图案在所述基础图像上是清晰的；

使用一个特征照相机获取代表所述物体的至少一部分的一个特征图像的特征图像数据，所述特征照相机是一个纹理照相机以及一个高分辨率照相机中的至少一个，所述纹理照相机是适配为捕获关于所述物体的所述部分的特征纹理信息的一种照相机，所述高分辨率照相机是适配为在一个高分辨率捕获关于所述物体的所述部分的高分辨率信息的一种照相机，所述高分辨率是高于所述基础分辨率；

从所述基础 2D 图像数据中提取 2D 点数据，这些 2D 点数据代表由所述投影的图案在所述表面上的一个反射所提供的多个 2D 表面点的至少一个集合；

使用所述 2D 点数据代表 2D 表面点的集合在所述传感器坐标系中计算多个 3D 表面点的一个集合；并且

在数学意义上将所述 3D 表面点的集合投影到所述特征图像数据上，以便获得所述 3D 表面点在所述特征图像数据中的一个位置；

在所述特征图像数据中在离所述投影的 3D 表面点一个短的距离处为所述 3D 表面点集合提取特征数据。

14. 如权利要求 13 所述的方法，其中所述基础 2D 图像以及所述特征图像是使用一个传

感装置获得的,该传感装置具有:一个图案投影器,该图案投影器用于在所述物体的所述表面上提供所述投影的图案;用于获取所述物体的一个基础 2D 图像的至少一个基础照相机;以及用于获取所述物体的一个特征图像的一个特征照相机;在一个传感器坐标系中所述基础照相机、所述图案投影器以及所述特征照相机的一种空间关系是已知的。

15. 如权利要求 13 和 14 中任何一项所述的方法,进一步包括:

获得多个变换参数,所述变换参数代表在所述传感器坐标系与一个全局坐标系之间的一种空间关系;

在所述全局坐标系中使用所述变换参数将所述 3D 表面点集合转换成多个被转换的 3D 表面点的一个集合。

16. 如权利要求 15 所述的方法,进一步包括:

积累该变换的 3D 表面点的集合以便提供所述物体的一个 3D 表面模型。

17. 如权利要求 16 所述的方法,进一步包括:

在该全局坐标系中从该变换的 3D 表面点集合计算多个局部切面的一个集合,使用所述局部切面来提供所述物体的所述 3D 表面模型。



Espacenet

Bibliographic data: CN102402799 (A) — 2012-04-04

Object classification for measured three-dimensional object scenes

Inventor(s): ROBERT DILLON; BING ZHAO ± (DILLON ROBERT, ; ZHAO BING)

Applicant(s): DIMENSIONAL PHOTONICS INTERNAT INC ± (DIMENSIONAL PHOTONICS INTERNATIONAL INC)

Classification: - **international:** A61C19/04; G06T19/00
- **cooperative:** A61C9/006; G06K9/00201; G06K2209/05

Application number: CN20111273996 20110909

Priority number (s): US20100381731P 20100910 ; US201113217652 20110825

Also published as: CN102402799 (B) EP2428913 (A2) EP2428913 (A3) US2012062716 (A1) JP2012059268 (A) more

Abstract of CN102402799 (A)

Described are methods that enable rapid automated object classification of measured three-dimensional object scenes. Each method can be performed during a three-dimensional measurement procedure while data are being acquired or after completion of the measurement procedure using the acquired data. In various embodiments, an object scene is illuminated with an optical beam and an image is acquired. In some embodiments, the object scene is illuminated with a structured light pattern and a sequence of images of the object scene illuminated by the pattern at different spatial phases is acquired. Coordinates are determined for points in the one or more images and a translucence value is determined for each of the points. An object class is determined for each point based on the translucence value for the point.; Optionally, additional information, such as grayscale or color image data for each point, is used to supplement the object class determination.

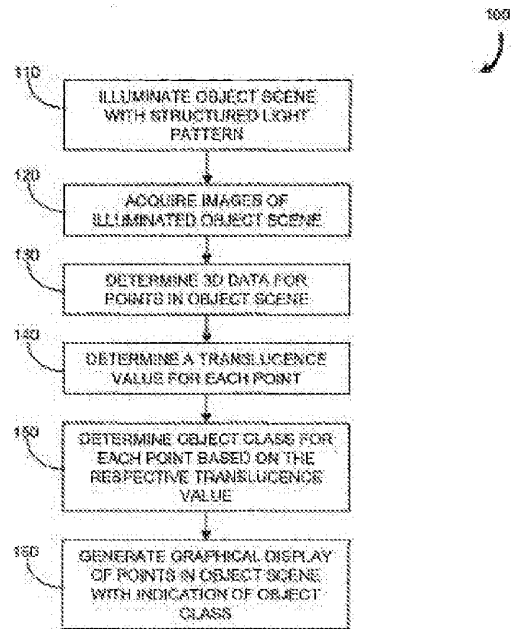
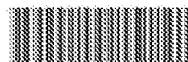

FIG. 4

(19) 中华人民共和国国家知识产权局



(12) 发明专利申请

(10) 申请公布号 CN 102402799 A

(43) 申请公布日 2012.04.04

(21) 申请号 201110277996.X

(22) 申请日 2011.09.09

(30) 优先权数据

61/381,731 2010.09.10 US

13/217,652 2011.08.25 US

(71) 申请人 三维光子国际公司

地址 美国马萨诸塞州

(72) 发明人 R·F·迪伦 B·赵

(74) 专利代理机构 北京纪凯知识产权代理有限公司
11245

代理人 赵睿民

(51) Int. Cl.

G06T 19/00(2011.01)

A61C 19/04(2006.01)

权利要求书 3 页 说明书 6 页 附图 4 页

(54) 发明名称

用于被测量的三维目标场景的目标分类

(57) 摘要

本发明描述能够进行被测量的三维目标场景的快速自动目标分类的方法。每种方法能够在获得数据的同时在三维测量过程中进行,或在利用所获得的数据完成测量过程之后进行。在各种实施例中,用光束照射目标场景并且获得图像。在一些实施例中,用结构光图案照射目标场景并且获得被在不同空间相位的该图案照射的该目标场景的一系列图像。确定在一个或多个图像中各点的坐标,并且确定每个点的半透明度值。基于每个点的半透明度值确定该点的目标类别。可选地,诸如每个点的灰度或彩色图像数据的附加信息用来补充该目标类别的确定。

CN 102402799 A

1. 一种口腔图像的目标分类的方法,该方法包括:
 - 用光束照射口腔的至少一部分;
 - 获得所述口腔的被照射部分的图像;
 - 确定所述图像中的多个点的坐标;
 - 确定每个点的半透明度值;以及
 - 基于每个点的半透明度值确定该点的目标类别。
2. 根据权利要求1的方法,其中确定每个点的目标类别包括将所述半透明度值和与目标类别关联的至少一个阈值进行比较。
3. 根据权利要求1的方法,还包括为每个点确定目标颜色,并且其中确定每个点的目标类别是基于所述半透明度值和所述目标颜色。
4. 根据权利要求1的方法,还包括为每个点确定目标灰度值,并且其中确定每个点的目标类别是基于所述半透明度值和所述目标灰度值。
5. 根据权利要求1的方法,其中所述坐标是所述口腔中的目标表面的3D坐标。
6. 根据权利要求1的方法,其中所述坐标是所述口腔的图像的2D坐标。
7. 一种目标场景的三维数据的目标分类的方法,该方法包括:
 - 用结构光图案照射目标场景;
 - 获得被照射的目标场景的图像;
 - 基于获得的图像确定在所述目标场景中的多个点的坐标;
 - 确定每个点的半透明度值;以及
 - 基于所述半透明度值确定每个点的目标类别。
8. 根据权利要求7的方法,其中照射所述目标场景包括投射具有单个波长的光。
9. 根据权利要求7的方法,其中照射所述目标场景包括投射具有多个波长的光。
10. 根据权利要求7的方法,其中照射所述目标场景包括投射具有连续波长光谱的光。
11. 根据权利要求7的方法,其中所述坐标是所述目标场景的三维坐标。
12. 根据权利要求7的方法,其中确定每个点的目标类别包括将所述半透明度值和与目标类别关联的至少一个阈值进行比较。
13. 根据权利要求7的方法,还包括为每个点确定目标颜色并且其中确定每个点的目标类别是基于所述半透明度值和所述目标颜色。
14. 根据权利要求7的方法,还包括为每个点确定目标灰度值,并且其中确定每个点的目标类别是基于所述半透明度值和所述目标灰度值。
15. 根据权利要求7的方法,还包括根据所述坐标生成所述点的图形显示,其中每个所述点具有指示该点的目标类别的图形表示。
16. 根据权利要求7的方法,其中所述坐标是2D图像坐标。
17. 根据权利要求16的方法,还包括生成所述2D图像坐标的图形显示,其中每个所述2D图像坐标具有指示所述2D图像坐标的目标类别的图形表示。
18. 根据权利要求15的方法,其中生成所述图形显示包括生成所述目标场景中的所述点的3D表面图表示。
19. 根据权利要求15的方法,其中生成所述图形显示包括生成3D点云显示。
20. 根据权利要求15的方法,其中指示所述目标类别的所述图形表示是颜色。

21. 根据权利要求 7 的方法,其中所述目标类别是从多个目标类别确定的,所述多个目标类别包括来自包括牙齿、牙龈和软组织的一组目标类别的至少两个目标类别。
22. 一种目标场景的三维数据的目标分类方法,该方法包括:
用每个具有不同空间相位的一系列结构光图案照射目标场景;
为每个所述结构光图案获得所述目标场景的图像;
基于获得的图像确定在所述目标场景中的多个点的坐标;
基于获得的图像确定每个点的背景强度值;以及
基于所述背景强度值确定每个点的目标类别。
23. 根据权利要求 22 的方法,其中所述背景强度值对应于所述目标场景中的所述点的半透明度。
24. 根据权利要求 22 的方法,还包括为每个点确定目标颜色并且其中确定每个点的目标类别是基于所述背景强度值和所述目标颜色。
25. 根据权利要求 22 的方法,还包括为每个点确定目标灰度值,并且其中确定每个点的目标类别是基于所述背景强度值和所述目标灰度值。
26. 根据权利要求 23 的方法,其中确定所述背景强度值包括:
计算数学地拟合于所述系列中的图像的点的所述强度值的正弦强度函数,所述正弦强度函数具有最大值和最小值;以及
确定所述背景强度值作为所述正弦强度函数的最小值。
27. 根据权利要求 22 的方法,其中目标类别的所述确定包括将背景强度值和与目标类别关联的至少一个阈值进行比较。
28. 根据权利要求 22 的方法,还包括根据所述坐标生成所述点的图形显示,其中每个所述点具有指示该点的目标类别的图形表示。
29. 根据权利要求 28 的方法,其中生成所述图形显示包括生成所述目标场景中的所述点的 3D 表面图表示。
30. 根据权利要求 28 的方法,其中生成所述图形显示包括生成 3D 点云显示。
31. 根据权利要求 28 的方法,其中指示所述目标类别的图形表示是颜色。
32. 根据权利要求 22 的方法,其中所述目标类别是从多个目标类别确定的,所述多个目标类别包括来自包括牙齿、牙龈和软组织的一组目标类别的至少两个目标类别。
33. 一种用于目标场景的目标分类的设备,包括:
照射目标场景的照明源;
成像器,所述成像器被配置成获得被照射的目标场景的图像并且提供包括所述目标场景的二维图像数据的输出信号;以及
处理器,所述处理器与所述成像器通信并且被配置成响应所述二维图像数据而确定表示在所述图像中的多个坐标的半透明度值,所述处理器还响应所述坐标的半透明度值来确定每个所述坐标的目标类别。
34. 根据权利要求 33 的设备,其中所述处理器响应所述二维图像数据来确定每个所述坐标的颜色,并且其中所述处理器响应所述坐标的半透明度值和颜色来确定每个所述坐标的目标类别。
35. 根据权利要求 33 的设备,其中所述处理器响应所述二维图像数据来确定每个所述

坐标的灰度值,并且其中所述处理器响应所述坐标的半透明度值和灰度值来确定每个所述坐标的目标类别。

36. 一种用于目标场景的目标分类的设备,包括:

投影仪,所述投影仪被配置成用一系列结构光图案照射目标场景;

成像器,所述成像器被配置成为所述系列中的每个结构光图案获得被照射的目标场景的图像,所述成像器针对每个所述图像提供包括所述目标场景的二维图像数据的输出信号;以及

处理器,所述处理器与所述成像器通信并且被配置成响应针对所述系列结构光图案的所述二维图像数据来确定所述目标场景的三维坐标和每个所述三维坐标的半透明度值,所述处理器还响应所述三维坐标的半透明度值来确定每个所述三维坐标的目标类别。

37. 根据权利要求 36 的设备,其中所述处理器响应所述二维图像数据来确定每个所述三维坐标的颜色,并且其中所述处理器响应所述三维坐标的半透明度值和颜色来确定每个所述三维坐标的目标类别。

38. 根据权利要求 36 的设备,其中所述处理器响应所述二维图像数据来确定所述每个所述三维坐标的目标灰度值,并且其中所述处理器响应所述三维坐标的半透明度值和目标灰度值来确定每个所述三维坐标的目标类别。

用于被测量的三维目标场景的目标分类

[0001] 相关申请

[0002] 本申请要求 2010 年 9 月 10 日提交的美国临时专利申请序列号 61/381,731 且名称为“Method of Data Processing and Display for a Three-Dimensional Intra-Oral Scanner(用于三维口腔内扫描器的数据处理和显示方法)”的优先权,其整个内容通过引用结合于此。

技术领域

[0003] 本发明一般涉及目标场景的三维(3D)成像。特别是,本发明涉及在目标场景的 3D 测量中在不同类别目标之间区分的方法。

背景技术

[0004] 在典型的牙科或医用 3D 摄像机或扫描器成像系统中,获得目标场景中的一个或更多目标表面的一系列二维(2D)亮度图像(intensity image),其中针对每个图像的照明可以变化。在一些系统中,结构光图案(structured light pattern)被投影在所述表面上并且在每个 2D 亮度图像中被检测。例如,投影的光图案可以通过将一对相对于光束投影在目标表面上并且得到在连续的 2D 图像之间变化的条纹图案来产生。替代地,投影的光图案可以是利用亮度掩膜(mask)和在连续的 2D 图像之间移动位置的投影图案产生的一系列投影的平行线。在其他种类型的 3D 成像系统中,采用诸如共焦成像的技术。

[0005] 在动态 3D 成像系统中,在摄像机或扫描器相对于目标场景运动时获得一系列 3D 数据组。例如,成像系统可以是使用者相对于目标场景手动定位的识别棒/扫描棒或其他手持式装置。在一些应用中,通过相对于目标移动该装置来测量多个目标表面,以便在一个位置中的从该装置的视野遮蔽的表面在另一个位置可以被该装置观察。例如,在牙科应用中,在静态视场中牙齿或其他牙齿特征的存在能够遮蔽其他牙齿的视野。处理单元自动记录(register)所有获得的 3D 数据的重叠区,以在测量过程期间得到所有被观察表面的完整 3D 数据组表示。

[0006] 3D 测量的结果可能难以解释。例如,口腔的测量通常包括诸如牙齿、假牙结构和牙龈的不同类别目标的 3D 数据。3D 数据能够以不同的图形格式呈现给用户,例如 3D 表面图(surface map)表示形式或 3D 点云形式的点的显示。在该显示中表示的不同结构之间的区分可能是问题并且需要很大的努力来适当地解释该显示中的特征。在一些例子中,临床医生或许不能区分开目标的相邻部分。例如,对于牙科专业人员而言,难以准确地识别牙龈和釉质或牙质之间的边界。

发明内容

[0007] 一方面,本发明以口腔图像的目标分类的方法为特征。该方法包括用光束照射口腔的至少一部分并且获得被照射部分的图像。确定该图像中多个点的坐标,并且确定每个点的半透明度值。基于每个点的半透明度值确定该点的目标类别。

[0008] 另一方面,本发明以目标场景的 3D 数据的目标分类方法为特征。该方法包括用结构光图案照射目标场景并且获得该被照射的目标场景的图像,基于获得的图像确定在该目标场景中的多个点的坐标。确定每个点的半透明度值并且基于每个点的半透明度值确定该点的目标类别。

[0009] 又一方面,本发明以目标场景的 3D 数据的目标分类方法为特征。该方法包括用每个具有不同空间相位的一系列结构光图案照射目标场景。针对每个结构光图案,获得该目标场景的图像。基于获得的图像确定该目标场景中的多个点的坐标。基于获得的图像确定每个点的背景强度值,并且基于每个点的背景强度值确定每个点的目标类别。

[0010] 再一方面,本发明以用于目标场景的目标分类的设备为特征。该设备包括照射目标场景的照明源、成像器以及与该成像器通信的处理器。成像器被配置成获得被照射的目标场景的图像并且提供包括该目标场景的 2D 图像数据的输出信号。处理器被配置成响应 2D 图像数据,确定表示在该图像中的多个坐标的半透明度值。处理器响应每个坐标的半透明度值来确定每个坐标的目标类别。

[0011] 再一方面,本发明以用于目标场景的目标分类的设备为特征。该设备包括投影仪、成像器以及与该成像器通信的处理器。投影仪被配置成用一系列结构光图案照射目标场景。成像器被配置成获得针对该系列中每个结构光图案的被照射目标场景的图像。对于每个图像,成像器提供包括该目标场景的 2D 图像数据的输出信号。处理器被配置成响应所述系列的 2D 图像数据,确定目标场景的 3D 坐标和每个 3D 坐标的半透明度值。处理器响应每个 3D 坐标的半透明度值而确定每个 3D 坐标的目标类别。

附图说明

[0012] 通过结合附图参考下面的说明能够更好地理解本发明的上述和其他优点,其中,在各图中相同的附图标记表示相同的结构元件和特征。为了清楚起见,不是在每个图中给每个元件都注上标记。附图不需要按比例绘制,而是将重点放在图解说明本发明的原理上。

[0013] 图 1 是示出能够被用来获得目标场景的 3D 图像的测量系统的例子块示意图。

[0014] 图 2 图解说明可操纵的识别棒,它是被用来获得口腔的 3D 测量数据的 3D 测量系统的一部分。

[0015] 图 3 图解说明如何用图 2 的识别棒进行上牙弓的 3D 测量。

[0016] 图 4 是根据本发明的实施例的目标场景的 3D 数据分类方法的流程图表示。

[0017] 图 5 是根据本发明的另一个实施例的目标场景的 3D 数据分类方法的流程图表示。

具体实施方式

[0018] 下面将参考在附图中示出的本发明的示范性实施例更加详细地描述本发明。虽然结合各种实施例和例子描述本发明,但不是想要将本发明限制于这些实施例。相反,正如本领域的技术人员将理解的,本说明包含各种替代方案、修改和等同物。已经接触在此的本发明的本领域普通技术人员将会认识到属于这里描述的本公开范围内的附加实现、修改和实施例以及其他使用领域。

[0019] 本发明的方法可以以可操作的方式包括任何描述的实施例或所描述的实施例的组合。简言之,本发明的方法能够进行被测量的 3D 目标场景的快速自动目标分类。正如这

里所用的,目标分类是指从被测量目标的多个可能的目标类别确定目标的类型或类别。在获得数据的同时在3D测量过程期间可以执行该方法。替代地,可以在用前面获得的数据完成测量过程之后执行该方法。在各种实施例中,用光束照射目标场景并且获得图像。确定图像中的各点的坐标并且确定每个点的半透明度值。基于每个点的半透明度值确定每个点的目标类别。可选地,每个点的灰度或彩色图像数据被用来补充目标类别确定。

[0020] 在下面描述的具体实施例中,若干方法涉及在口腔的3D测量——例如在牙科应用中由临床医生进行的测量期间或之后3D数据的目标分类。被测量的表面可以包括牙齿的釉质表面、牙齿的牙质下部结构、牙龈、各种牙结构(例如桩、植入物和填充物)以及软组织(例如舌或唇)。用于口腔测量的3D测量数据的分类能够在对应于这些不同目标类别的3D数据中进行区分。区分不同类型目标的能力允许3D测量数据以示出在被测量的目标场景中的目标类别的方式显示。而且,因此能够管理来自不感兴趣的目标的3D测量数据。例如,通过口腔测量应用中的测量视场的舌或唇的运动能够使来自干扰目标的数据被获得。可以抛弃这种不想要的的数据或防止其破坏想要的目标场景即牙齿和牙龈的测量。应当意识到这些方法也能够应用于医疗应用和在其中为具有多个目标类别的目标场景获得3D测量数据的其他应用。

[0021] 在下面描述的一些实施例中,3D测量系统利用由于干涉测量条纹投影或其他技术产生的结构照明图案。成像部件获得2D图像,以基于目标的结构照明确定目标表面上的各点的坐标信息。

[0022] 通过引用结合于此的美国专利5,870,191号描述了一种叫做云纹干涉测量法(Accordion Fringe Interferometry, AFI)的技术,这种技术基于干涉测量条纹投影能够被用于高精度3D测量。基于AFI的3D测量系统通常采用两个紧密间隔的相干光源,以将干涉测量条纹图案投影在目标的表面上。针对该条纹图案的至少三个空间相位的条纹图案的图像被获得。

[0023] 图1图解说明基于AFI的3D测量系统10,该系统被用来得到一个或多个目标22的3D图像。由条纹投影仪18产生的两个相干的光束14A和14B被用来以干涉条纹26的图案照射目标22的表面。在目标22的干涉图案的图像由成像系统或透镜30形成在包括光电探测器34的阵列的成像器上。例如,探测器阵列34可以是二维电荷耦合器件(CCD)成像阵列。由探测器阵列34产生的输出信号被提供给处理器38。输出信号包括关于在阵列34中的每个光电探测器处接收的光的强度的信息。可选的偏振器42定向或与散射光的主偏振分量一致。控制模块46控制从条纹投影仪18发射的两个相干的光束14的参数。控制模块46包括调节两个光束14的相位差的相移控制器50和调节在目标22处的干涉条纹26的间距或间隔的空间频率控制器54。

[0024] 条纹图案的空间频率由在条纹投影仪18中的相干光辐射的两个虚拟源的间隔、从虚拟源到目标22的距离以及辐射的波长确定。尽管实际的光辐射源可以位于在别处,但是虚拟源是光辐射看起来像是从其起源的点。处理器38和控制模块46通信以关于相位差和空间频率的变化来协调来自光电探测器阵列34的信号的处理,并且处理器38根据条纹图案图像确定目标表面的3D信息。

[0025] 处理器38基于在条纹图案的连续相移之后产生的一系列2D图像中的像素的强度值,为每个像素计算从成像系统30和探测器阵列34到目标表面的距离。因此处理器生成

能够显示为表示目标表面的点云或表面图的一组 3D 坐标。处理器 38 与用于存储在测量过程期间产生的 3D 数据的存储器模块 58 通信。用户接口 62 包括输入装置和显示器,以使诸如临床医师的操作者能够提供操作者指令并且使操作者能够以接近实时的方式观察获得的 3D 信息。例如,在目标 22 的表面的不同区被测量并且获得附加的 3D 测量数据时,操作者能够观察点云或表面图的图形表示的增长的显示。

[0026] 图 2 图解说明可操纵的识别棒 66 的形式的手持式 3D 测量装置,该装置可被用来获得口腔的 3D 测量数据。识别棒 66 包括通过柔性电缆 74 连接于处理器和系统其他部件(未示出)的主体部分 70。识别棒 66 产生从投影端 82 附近投影的结构光图案 78,以照射要被测量的目标场景。例如,结构光图案 78 可以是基于如上面针对图 1 描述的 AFI 测量系统的原理的干涉测量条纹图案。识别棒 66 可被用来获得一部分牙弓的 3D 数据。识别棒 66 由临床医生在口腔内操作,因此获得可被结构光图案 78 照射的所有表面的 3D 数据。

[0027] 图 3 示出如何用图 2 的识别棒 66 进行上牙弓的 3D 测量的例子。在这个例子中,识别棒 66 是 AFI 型 3D 测量系统的可操纵部件。在牙弓的口腔扫描的一部分期间,从识别棒 66 将条纹投影在测量视场 94 中的牙齿 86 和邻近的牙龈组织 90 上。优选地,从测量扫描获得的 3D 数据对临床医生显示为示出牙齿 86 和牙龈 90 的被测量表面的 3D 点云或表面图(例如,线框表示)。

[0028] 参考图 1,成像阵列 34 接收投影在测量视场 94 的范围内的牙齿 86 和相邻牙龈 90 上的条纹图案的图像。由于釉质的半透明性质,在投影的条纹图案中的一些光透过牙齿的表面并且在表面下面的区域中散射。散射的光通常导致条纹图案的图像变差。半透明性的程度确定条纹图案中透过表面并在下面散射的光的量。如果来自表面下面的区域的散射光相对于来自在表面的条纹照射的散射光的是数量上非常大的,则图像中的条纹图案的表现位置(即,表现相位)能够不同于在牙齿 86 的表面上的条纹图案的实际位置。优选地,投影仪 18 利用增加靠近表面的内部散射的照射波长。例如,条纹照射可以包括近紫外波长或较短的可见波长(例如从大约 350nm 到 500nm),和较长的波长相比,这种波长导致靠近表面的更多散射和在该表面的下面的较少透过。此外,优选地,条纹图案被构造成为具有高空间频率,使得从浅的表面下区域散射的光给条纹图案的图像带来几乎均匀的背景光。在处理 2D 图像以确定牙齿 86 的 3D 数据期间,来自表面下区域的背景影响被忽略。而且,来自表面下区域的任何空间变化的强度影响引起的残差的大小不太重要,因为该影响被限制在每个牙齿 86 的表面之下的浅区。在示范性的实施例中,投影的条纹图案的波长是 405nm,并且在牙齿表面的条纹图案的空间频率或间距是至少 1 条纹/mm。

[0029] 图 4 是针对目标场景的 3D 数据的目标分类方法 100 的流程图表示。方法 100 包括用结构光图案照射目标场景(步骤 110)。例如,结构光图案可以是由相干光束的干涉或阴影掩膜投影产生的条状强度图案。获得被照射的目标场景的图像(步骤 120)。在一些应用中,目标场景对应于 3D 成像装置的测量视场并且通过操作该装置使得测量视场包括较大的目标场景的其他区来测量较大的目标场景。从该获得的图像确定该目标场景表面上的 3D 点的坐标(步骤 130)。

[0030] 确定每个被测量的 3D 点的半透明度值(步骤 140)。目标场景可以包括可相互区别的多个目标。例如,两个目标可以由具有不同半透明度的不同材料组成。因此半透明度值可以被用来为点确定目标的类型或目标类别(步骤 150)。目标分类可以基于将半透明度

值与一个或更多个和不同目标类型关联的阈值进行比较。例如,目标分类可以基于确定在多个半透明度值范围中的那个范围包括该点的半透明度值。在这个例子中,每个半透明度值范围对应于唯一的目标分类。可选地,对应于从对应目标表面散射的光的幅值的反射率值与半透明度值组合使用,以确定目标类别。在这种情况下,将反射率值和反射阈值或阈值的范围进行比较,反射阈值或阈值的范围和半透明度值组合来与各种目标类别关联。

[0031] 生成目标场景的图形显示(步骤160)。该显示包括针对每个点的目标类别的指示。例如,该显示可以是3D表面图表示,其中线框表示、表面元件描绘等用不同的颜色显示,以指示目标类别。其他的图形参数可以用来指示每个点的目标分类。在另一个例子中,显示可以是3D点云,其中每个点具有与其目标分类关联的颜色。在一些实施例中,图形显示可以包括边界线或类似特征,以将目标场景的不同区分段成或区别成图形目标,使得不同的目标能够被容易地识别。

[0032] 可选地,获得目标场景的被照射区的彩色图像。为每个点获得的彩色数据可以与每个点的半透明度值组合使用,以确定每个点的目标类别。在被动照明设备或诸如白光光源或窄带光源的补充光源能够用来改进通过颜色进行区别的能力的情况下,能够获得彩色图像。在替代实施例中,诸如红光、绿光和蓝光发光二极管(LED)的光谱光源的顺序操作可以用来产生RGB图像。以这种方式,单色成像器可以用来产生彩色数据,以补充目标分类。

[0033] 在另一替代选择中,获得目标场景的被照射区的灰度图像。每个点的目标灰度值与该点的半透明度值组合使用,以确定该点的目标类别。灰度图像可以用被动照明设备获得,或者可以使用补充光源。

[0034] 图5是目标场景的3D数据的目标分类方法200的实施例的流程图表示。方法200包括用一系列不同空间相位的结构光图案照射目标场景(步骤210)。优选地,结构光图案是在一维中具有正弦强度变化的干涉测量强度图案,例如,正弦强度图案通过如在上面关于图1描述的两个相干光束的干涉产生。优选地,该系列包括一组三个正弦强度图案,每个具有偏离另外两个正弦强度图案 120° 的空间相位。

[0035] 针对该系列中的每个光图案,获得被照射的目标场景的图像(步骤220)。基于该系列结构光图案的图像确定目标场景中点的3D数据(步骤230)。

[0036] 为来自该系列图像的每个点计算背景强度值(步骤240)。一般来说,如果目标场景的其他照射源被保持在低水平并且如果图像获得时间充分短,则在目标场景中的点的背景强度值主要是由于与该点关联的目标的半透明度引起的。因此背景强度值可以用作该点的半透明度(即,半透明度值)的度量。在基于三个正弦强度图案的投影的实施例中,通过首先将正弦强度变化数学地拟合到被照射的目标场景中点位置的三个强度值来确定该点的背景强度值。例如,数学拟合可以是正弦函数的最小二乘方拟合。背景强度存在于该系列的所有图像中并且使对比度变差。背景强度的值被确定为已拟合的正弦函数的最小值。

[0037] 由于背景强度值与半透明度值紧密相关,背景强度值水平可以用来确定该点的目标类型或目标类别(步骤250),例如通过将背景值和与不同目标类型关联的与一个或更多个阈值或背景强度值范围进行比较。在另外的实施例中,目标分类是两步比较,其中目标分类还包括将拟合的正弦函数的最大值与一个或更多个阈强度值进行比较。

[0038] 生成目标场景的图形显示(步骤260)并且该图形显示包括每个点的目标类别的

指示。该显示可以是如上面关于图 4 的方法描述的表面图表示或 3D 点云的任何类型,其中颜色或其他图形特征用来指示不同的目标类别和结构。可选地,获得目标场景的彩色或灰度图像并且将所述图像与背景强度值组合使用,以确定目标类别。

[0039] 虽然上面描述的实施例主要涉及其中利用结构光图案照射目标场景的目标分类,但是将会认识到,通过确定半透明度的目标分类可以在更一般的照射条件下进行。例如,可以用允许确定目标上的点或区的半透明度值的任何方式以光束照射目标场景。光相干断层摄影 (OCT) 系统和共焦点的显微系统是能够适于半透明度测量和目标分类的测量系统的例子。诸如波长或光谱宽度的光束特性可以被选择,以最好地有助于不同目标类型之间的区分。而且,目标场景的灰度或彩色图像数据可以用在各种实施例中,以提高目标分类能力。

[0040] 虽然已经参考具体实施例示出并描述了本发明,但是本领域的技术人员应当理解,在不脱离由权利要求限定的本发明的精神和范围的情况下可以进行各种形式和细节的修改。



图1



图2

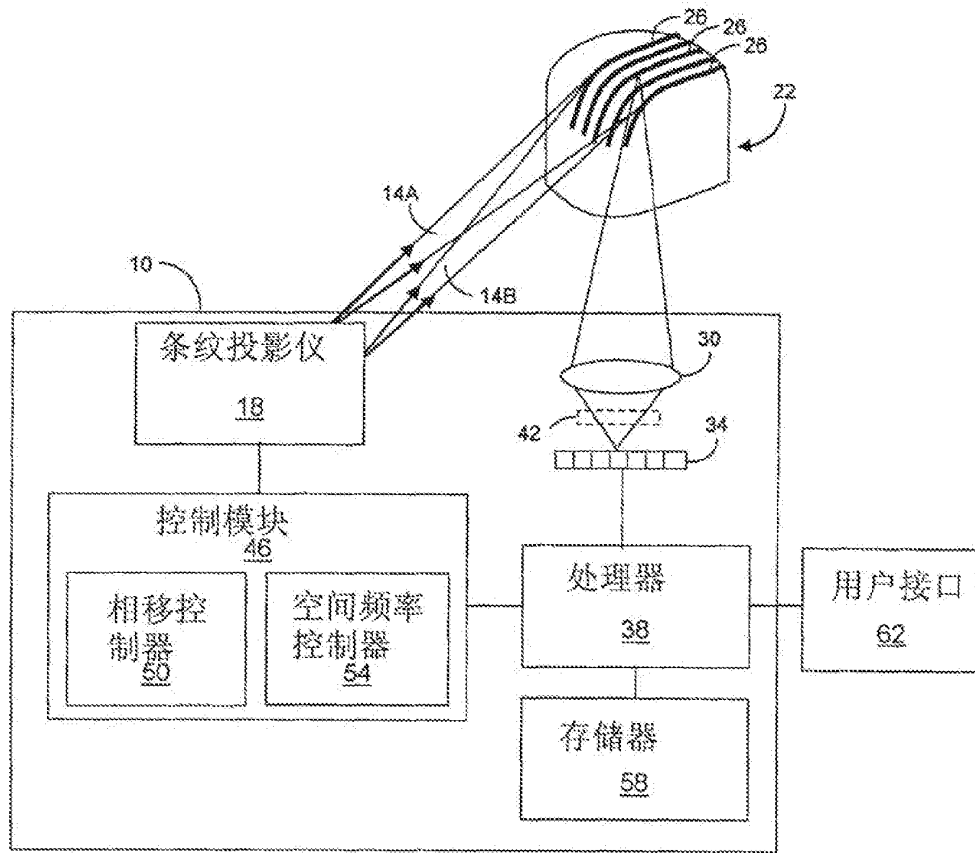

图3

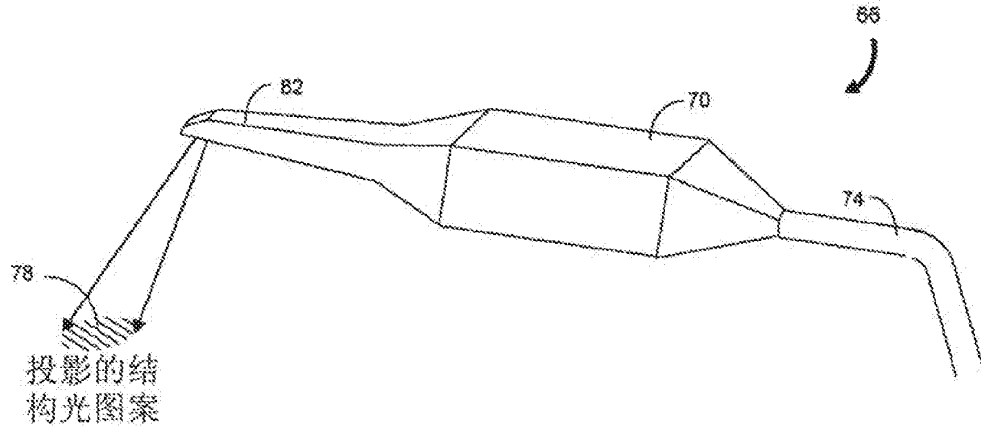

图4

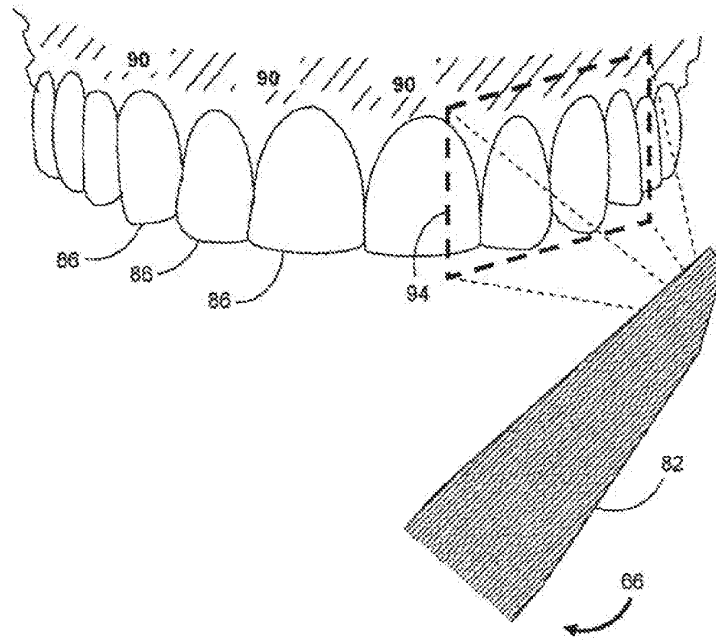

图5

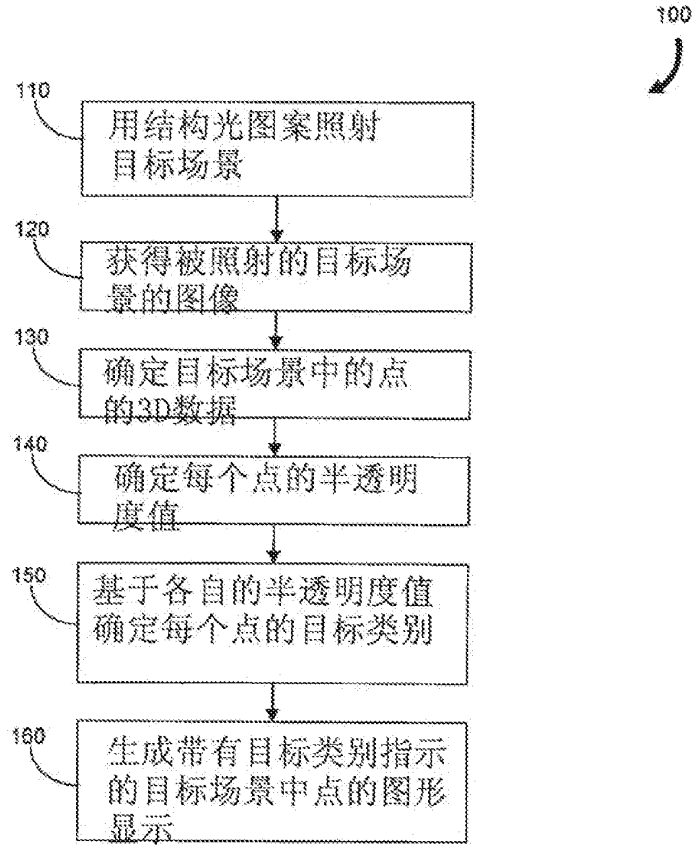

Espacenet

Bibliographic data: CN102802520 (A) — 2012-11-28

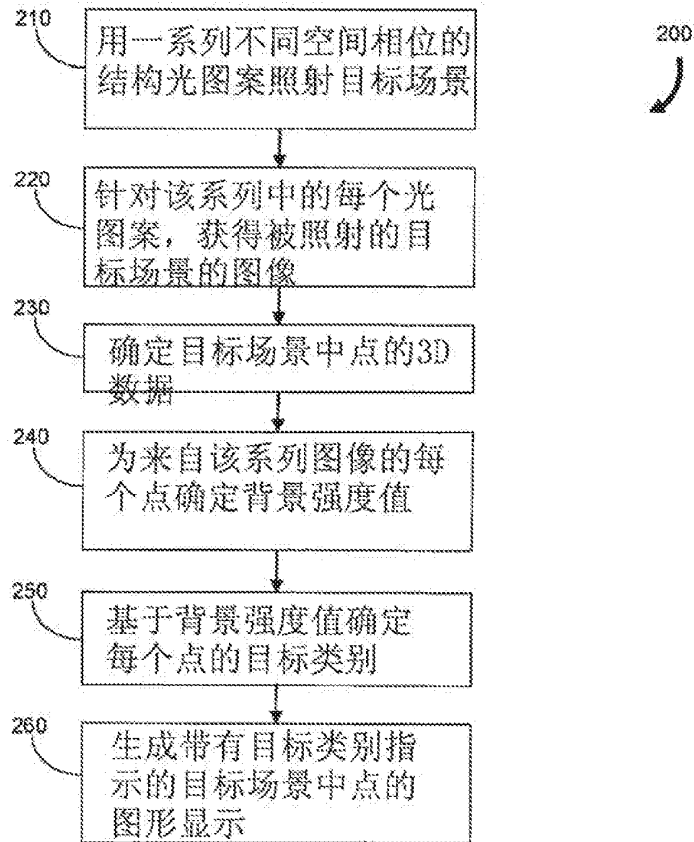
Focus Scanning Apparatus

Inventor(s): RUNE FISKER; HENRIK OEJELUND; RASMUS KJAER; MIKE DER POEL VAN; QAZI ARISH A; KARL-JOSEF HOLLENBECK ± (FISKER RUNE, ; OEJELUND HENRIK, ; KJAER RASMUS, ; VAN DER POEL MIKE, ; QAZI ARISH A, ; HOLLENBECK KARL-JOSEF)

Applicant(s): 3SHAPE AS ± (3SHAPE AS)

Classification: - **international:** A61B5/107
 - **cooperative:** A61B5/0068; A61B5/1077; G01B11/2513; G01B11/2518; H04N13/0296; A61B5/1075; A61B5/1076; A61B5/4547; G01B2210/58

Application number: CN2010827248 20100617

Priority number(s): WO2010DK50148 20100617 ; US20090187744P 20090617 ; US20090231118P 20090804

Also published as: CN102802520 (B) WO2010145669 (A1) US2015054922 (A1) US2012092461 (A1) US8878905 (B2) more

Abstract of CN102802520 (A)

Disclosed is a handheld scanner for obtaining and/or measuring the 3D geometry of at least a part of the surface of an object using confocal pattern projection techniques. Specific embodiments are given for intraoral scanning and scanning of the interior part of a human ear.

(19) 中华人民共和国国家知识产权局

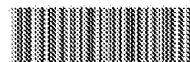

(12) 发明专利申请

(10) 申请公布号 CN 102802520 A

(43) 申请公布日 2012.11.28

(21) 申请号 201090027248.7

(51) Int. Cl.

(22) 申请日 2010.06.17

A61B 5/107(2006.01)

(30) 优先权数据

61/187,744 2009.06.17 US

61/231,118 2009.08.04 US

(85) PCT申请进入国家阶段日

2011.12.19

(86) PCT申请的申请数据

PCT/DK2010/050148 2010.06.17

(87) PCT申请的公布数据

W02010/145669 EN 2010.12.23

(71) 申请人 3 形状股份有限公司

地址 丹麦哥本哈根

(72) 发明人 R·费斯克 亨里克·奥杰伦德

拉斯马斯·克耶尔 迈克·菲德普尔

阿瑞什·A·卡齐

卡尔-约瑟夫·霍伦贝克

(74) 专利代理机构 北京安信方达知识产权代理

有限公司 11262

代理人 张春媛 阎敏斌

权利要求书 9 页 说明书 28 页 附图 18 页

(54) 发明名称

聚焦扫描设备

(57) 摘要

披露了一种手持式扫描器,用于利用共焦图案投影技术获得和/或测量物体的至少一部分表面的 3D 几何形状。针对口内扫描和人耳内部部分的扫描给出了具体实施例。

CN 102802520 A

1. 一种用于获得和/或测量物体的至少一部分表面的3D几何形状的扫描器,所述扫描器包括:
 - 至少一个容纳感测器元件阵列的照相机,
 - 用于产生整合空间图案的探测光的装置,
 - 用于将探测光向物体传输的装置,由此利用一种或多种构形的所述图案照明物体的至少一部分,
 - 用于传输从物体返回到照相机的光的至少一部分的装置,
 - 用于改变物体上的图案的焦平面的位置,同时保持扫描器与物体之间的固定空间关系的装置,
 - 用于从所述感测器元件阵列获得至少一个图像的装置,
 - 用于在每个焦平面位置估计至少一个图像像素和加权函数之间的相关度的装置,其中加权函数基于空间图案的构形信息而确定,
 - 数据处理装置,用于:
 - a) 通过相关度的分析确定下列对象的准确对焦位置:
 - 对于一系列焦平面位置,多个图像像素中的每一个,或者
 - 对于一系列焦平面位置,多个图像像素组中的每个组,和
 - b) 将准确对焦数据转换成3D真实世界坐标。
2. 根据权利要求1的扫描器,其中从物体返回到照相机的光是反射光和/或散射光和/或荧光和/或磷光。
3. 根据权利要求1或2的扫描器,其中用于估计相关度的装置是数据处理装置。
4. 根据权利要求1或2的扫描器,其中用于估计相关度的装置是光学装置。
5. 根据前述任何一项权利要求的扫描器,其中相关度被以数学方式找出,基本上作为可选平滑的点积系列的至少局部的极值位置,所述点积针对多个所述焦平面位置计算。
6. 根据前一项权利要求的扫描器,其中每个点积由具有超过一个元素的信号向量和与加权的所述信号向量具有相同长度的加权向量来计算,所述元素代表感测器信号。
7. 根据前述任何一项权利要求的扫描器,其中图案是随时间变化的。
8. 根据前一项权利要求的扫描器,其中时变图案是随时间周期性的变化的。
9. 根据前述任何一项权利要求的扫描器,其中图案是静止的。
10. 根据前述任何一项权利要求的扫描器,其中用于传输从物体返回到照相机的光的装置包括用于将具有所述图案的物体的所述照明部分成像到照相机上的装置。
11. 根据前述任何一项权利要求的扫描器,其中用于传输从物体返回到照相机的光的装置包括用于将图案本身成像到照相机上并且将从物体返回的光叠加到照相机的装置,从而使照相机上的图像基本上是具有所述图案的物体的所述照明部分与图案本身的乘积。
12. 根据前述任何一项权利要求的扫描器,其中所述图案的嵌入空间结构是随时间变化的。
13. 根据前述任何一项权利要求的扫描器,包括至少一个光源和图案产生装置。
14. 根据前一项权利要求的扫描器,其中来自所述探测光产生装置的光通过所述图案产生装置传输,由此产生图案。
15. 根据权利要求13或14中任何一项的扫描器,其中所述图案产生装置包括透明和不

透明部件的遮盖件。

16. 根据前一项权利要求的扫描器,其中所述不透明部件吸收入射光。

17. 根据前述任何一项权利要求的扫描器,其中所述图案具有平移和/或旋转周期。

18. 根据前述任何一项权利要求的扫描器,其中通过平移和/或旋转所述图案使照明物体的所述图案随时间变化。

19. 根据权利要求 13-18 中任何一项的扫描器,其中从物体返回的光在成像到所述照相机上之前通过所述图案产生装置再次传输,优选地以与探测光相反的方向再次传输。

20. 根据前述任何一项权利要求的扫描器,其中照明物体的图案的图像与图案本身的图像重合。

21. 根据前述任何一项权利要求的扫描器,进一步包括用于使所述感测器元件的曝光时间与图案振荡时间同步的装置。

22. 根据前述任何一项权利要求的扫描器,其中所述感测器元件的曝光时间是光振荡周期的整数倍。

23. 根据前述任何一项权利要求的扫描器,其中所述感测器元件的曝光时间是光振荡周期的许多倍,例如光振荡周期的至少 10 倍,例如光振荡周期的至少 100 倍。

24. 根据权利要求 13-23 中任何一项的扫描器,其中来自光源的光通过图案产生装置传输,由此产生图案。

25. 根据前述任何一项权利要求的扫描器,其中照相机的焦平面适合于与图案的焦平面同步移动。

26. 根据前述任何一项权利要求的扫描器,其中物体是解剖学物体,例如耳道或诸如牙齿的牙科物体。

27. 根据前述任何一项权利要求的扫描器,包括用于将探测光向物体传输和/或将从物体返回到照相机的光成像的光学系统。

28. 根据前述任何一项权利要求的扫描器,进一步包括位于光路中的至少一个分束器。

29. 根据前述任何一项权利要求的扫描器,其中借助至少一个分束器将物体的图像形成在照相机中。

30. 根据前述任何一项权利要求的扫描器,其中沿着与从物体向照相机传输的反射光相同的光轴将图案向物体传输。

31. 根据前述任何一项权利要求的扫描器,其中光学系统包括透镜系统。

32. 根据前述任何一项权利要求的扫描器,其中一个透镜系统将图案向物体传输并且使从物体返回到照相机的光成像。

33. 根据前述任何一项权利要求的扫描器,其中一个透镜系统将图案向物体传输并且使从物体返回到图案产生装置的光成像。

34. 根据权利要求 31-33 中的扫描器,其中透镜系统是焦阑的或接近焦阑的。

35. 根据前述任何一项权利要求的扫描器,其中沿从物体到照相机成像的光的相反方向传输图案。

36. 根据前述任何一项权利要求的扫描器,其中沿从物体到图案产生装置成像的光的相反方向传输图案。

37. 根据前述任何一项权利要求的扫描器,其中感测器信号是基本上从物体表面反射

的积分光强度。

38. 根据前述任何一项权利要求的扫描器,其中焦平面位置以预定频率周期性地变化。

39. 根据前一项权利要求的扫描器,其中所述频率为至少 1Hz,例如至少 2Hz、3、4、5、6、7、8、9 或至少 10Hz,例如至少 20、40、60、80 或至少 100Hz。

40. 根据前述任何一项权利要求的扫描器,进一步包括至少一个聚焦元件。

41. 根据前一项权利要求的扫描器,其中聚焦元件是透镜系统的一部分。

42. 根据权利要求 40-41 中任何一项的扫描器,进一步包括用于调节和控制聚焦元件的装置。

43. 根据权利要求 40-42 中任何一项的扫描器,其中聚焦元件是单个透镜。

44. 根据权利要求 40-43 中任何一项的扫描器,进一步包括用于调节聚焦元件的位置的平移台。

45. 根据权利要求 40-44 中任何一项的扫描器,其中聚焦元件沿光轴前后平移。

46. 根据权利要求 31-45 中任何一项的扫描器,其中透镜系统对于所有的焦平面位置是焦阑的或接近焦阑的。

47. 根据权利要求 40-46 中任何一项的扫描器,进一步包括焦传动。

48. 根据前一项权利要求的扫描器,其中焦传动在 0.1 和 100 之间,例如在 0.1 和 1 之间,例如在 1 和 10 之间,例如在 2 和 8 之间,例如在 3 和 6 之间,例如至少 10,例如至少 20。

49. 根据权利要求 40-48 中任何一项的扫描器,进一步包括用于减小和/或消除来自聚焦元件调节系统的震动和/或晃动的装置,由此增加扫描器的稳定性。

50. 根据权利要求 40-49 中任何一项的扫描器,进一步包括用于固定和/或保持聚焦元件调节系统的质量中心的装置。

51. 根据权利要求 40-50 中任何一项的扫描器,进一步包括用于减小和/或消除来自聚焦元件调节系统的一阶、二阶、三阶和/或更高阶震动和/或晃动的装置,由此增加扫描器的稳定性。

52. 根据前述任何一项权利要求的扫描器,进一步包括基本上配衡聚焦元件的移动的配重。

53. 根据前一项权利要求的扫描器,进一步包括用于与聚焦元件的移动相反地平移配重的装置。

54. 根据权利要求 52 或 53 的扫描器,其中配重和聚焦元件相连并且通过相同的平移装置驱动。

55. 根据权利要求 40-54 中任何一项的扫描器,其中聚焦元件是液体透镜。

56. 根据权利要求 13-55 中任何一项的扫描器,其中图案产生装置包括具有不透明遮盖件的至少一个半透明和/或透明图案元件。

57. 根据前述任何一项权利要求的扫描器,其中图案是静止线图案或静止棋盘图案。

58. 根据权利要求 56 或 57 的扫描器,进一步包括用于旋转和/或平移图案元件的装置。

59. 根据权利要求 56-58 中任何一项的扫描器,其中所述图案元件是轮。

60. 根据权利要求 56-59 中任何一项的扫描器,其中所述遮盖件具有旋转和/或平移周期。

61. 根据权利要求 56-60 中任何一项的扫描器,其中所述遮盖件包括多个径向辐条,优选地以对称顺序布置。

62. 根据权利要求 56-61 中任何一项的扫描器,其中图案元件位于光路中。

63. 根据权利要求 56-62 中任何一项的扫描器,其中通过图案元件传输光,优选地通过图案元件横向传输。

64. 根据权利要求 56-63 中任何一项的扫描器,其中通过旋转和/或平移图案元件产生时变图案。

65. 根据前述任何一项权利要求的扫描器,包括至少一个分段光源,例如分段 LED。

66. 根据前一项权利要求的扫描器,其中借助所述分段光源产生图案。

67. 根据权利要求 65 或 66 中任何一项的扫描器,其中通过打开和关闭分段光源的多个单独的段而产生时变图案。

68. 根据权利要求 7 到 67 中任何一项的扫描器,进一步包括用于使时变图案振荡与感测器元件的积分时间同步的装置。

69. 根据权利要求 13 到 68 中任何一项的扫描器,进一步包括登记和/或监测图案产生装置和/或时变图案的相位和/或位置和/或角位置的装置。

70. 根据权利要求 56 到 69 中任何一项的扫描器,其中借助图案元件上的位置编码器登记图案元件和/或时变图案的相位和/或位置和/或角位置。

71. 根据权利要求 7 到 70 中任何一项的扫描器,进一步包括用于在一个图案振荡周期中对多个感测器元件中的每一个取样多次的装置,优选地取样整数次,例如在每个图案振荡周期中取样 2、3、4、5、6、7 或 8 次,由此用下列公式确定相关度:

$$A_j = \sum_{i=1}^n f_{i,j} / I_{i,j}$$

其中 n 是取样次数, A_j 是感测元件 j 的估计的相关度, $f_{1,j}, \dots, f_{n,j}$ 是基于每次取样的空间图案构形信息的加权函数值,而 $I_{1,j}, \dots, I_{n,j}$ 是在每次取样记录的感测器信号。

72. 根据前述任何一项权利要求的扫描器,其中物体表面的至少一部分成像在照相机中。

73. 根据前述任何一项权利要求的扫描器,其中图案与物体表面的至少一部分的叠加成像在照相机中。

74. 根据权利要求 13 到 73 中任何一项的扫描器,其中从物体反射的光在进入照相机之前再次传输通过图案产生装置,优选地沿相反的方向再次传输。

75. 根据权利要求 7 到 74 中任何一项的扫描器,进一步包括用于在多个图案振荡周期上,例如在多达 2、5、10、20、50、100、250、500、1000、5000 或多达 10000 个图案振荡周期上,记录多个感测器元件中的每一个的装置。

76. 根据前一项权利要求的扫描器,进一步包括用于在一系列焦平面位置上确定多个感测器元件中的每一个的最大信号值的装置。

77. 根据前述任何一项权利要求的扫描器,其中测量的 3D 几何形状的分辨率等于照相机的分辨率。

78. 根据前述任何一项权利要求的扫描器,其中测量的 3D 几何形状的分辨率低于照相机的分辨率,例如低至少 2 倍,例如低至少 3 倍,例如低至少 4 倍,例如低至少 5 倍。

79. 根据前述任何一项权利要求的扫描器,其中感测器元件阵列被分为感测器元件组,优选地矩形组,例如感测器元件的正方形组,优选地相邻的感测器元件的正方形组。

80. 根据前述任何一项权利要求的扫描器,其中图案例如线图案或棋盘图案的图像与感测器元件阵列的行和/或列对齐。

81. 根据前述任何一项权利要求的扫描器,其中至少一个空间周期的图案对应于感测器元件组。

82. 根据前述任何一项权利要求的扫描器,其中图案的一个或多个边与感测器元件阵列的一个或多个边对齐和/或重合。

83. 根据前述任何一项权利要求的扫描器,其中一组感测器元件中的相关度借助于下列公式确定: $A_j = \sum_{i=1}^n f_{i,j} I_{i,j}$,其中 A_j 是具有下标 j 的感测器元件组的相关度, n 是组内的感测器元件数量, $f_{1,j}, \dots, f_{n,j}$ 是基于空间图案构形信息的加权函数值,和 $I_{1,j}, \dots, I_{n,j}$ 是在组内的每个感测器元件的记录的感测器信号。

84. 根据前一项权利要求的扫描器,其中加权函数在一组感测器元件上的积分为零,即 $0 = \sum_{i=1}^n f_{i,j}$,该组具有下标 j ,由此除去相关度的DC部分。

85. 根据前述任何一项权利要求的扫描器,进一步包括用于将镜面反射光和/或漫反射光选择地成像的装置。

86. 根据前述任何一项权利要求的扫描器,进一步包括用于使探测光偏振的装置,例如偏振元件。

87. 根据前述任何一项权利要求的扫描器,进一步包括至少一个偏振光束分光器。

88. 根据前述任何一项权利要求的扫描器,其中借助至少一个偏振光束分光器将物体的图像形成在照相机中。

89. 根据前述任何一项权利要求的扫描器,进一步包括用于改变探测光和/或从物体反射的光的偏振状态的装置。

90. 根据前述任何一项权利要求的扫描器,进一步包括位于光路中的线偏振元件和延迟板,延迟板例如是四分之一波长延迟板。

91. 根据前述任何一项权利要求的扫描器,进一步包括至少一个光反射元件,其优选地沿光轴放置,用于沿不同于光轴的方向引导探测光和/或将物体成像,光反射元件例如是镜子。

92. 根据前一项权利要求的扫描器,进一步包括用于沿光轴的方向增加被扫描表面的延长的装置。

93. 根据前述任何一项权利要求的扫描器,包括至少两个光源,例如具有不同波长和/或不同偏振的光源。

94. 根据前一项权利要求的扫描器,进一步包括用于控制所述至少两个光源的控制装置。

95. 根据权利要求93或94中任何一项的扫描器,进一步包括用于合成和/或由并来自至少两个光源的光的装置,所述光源例如是具有不同波长和/或不同偏振状态的光源。

96. 根据权利要求93到95中任何一项的扫描器,进一步包括用于将来自至少两个光源例如具有不同波长和/或不同偏振状态的光源的光分开的装置。

97. 根据前述任何一项权利要求的扫描器,进一步包括部分光传输和部分光反射的至

少一个光学设备,所述光学设备优选地沿光轴放置,光学设备例如有涂层的镜子或有涂层的板。

98. 根据前一项权利要求的扫描器,包括至少两个所述光学设备,所述光学设备优选地沿光轴移动。

99. 根据权利要求 97 或 98 的扫描器,其中所述光学设备中的至少一个传输具有一定波长和 / 或偏振的光并且反射具有其它波长和 / 或偏振的光。

100. 根据权利要求 97 到 99 中任何一项的扫描器,包括至少第一和第二光源,所述光源具有不同的波长和 / 或偏振,和其中:

沿光路放置的第一光学设备以不同于光轴的方向反射来自所述第一光源的光并且传输来自所述第二光源的光,和

位于光路更后方的第二光学设备以不同于光轴的方向反射来自所述第二光源的光。

101. 根据前一项权利要求的扫描器,其中所述第一和第二光学设备沿平行方向反射探测光,优选地沿垂直于光轴的方向,由此使物体表面的不同部分成像。

102. 根据前一项权利要求的扫描器,其中所述物体表面的不同部分是至少部分重叠的。

103. 根据权利要求 93 到 102 中任何一项的扫描器,包括用于提供光源和聚焦元件的配合的控制装置。

104. 根据前述任何一项权利要求的扫描器,进一步包括至少一个弯曲的折光镜,用于以不同于光轴的方向,例如沿垂直于光轴的方向,引导探测光和 / 或使物体成像。

105. 根据前一项权利要求的扫描器,进一步包括一个或多个光学元件,例如透镜,其具有可为非球面的表面以提供修正的光学成像。

106. 根据前述任何一项权利要求的扫描器,进一步包括至少一个光栅,用于沿不同于光轴的方向,例如沿垂直于光轴的方向,引导探测光和 / 或使物体成像。

107. 根据前一项权利要求的扫描器,其中光栅提供失真的放大,由此在被扫描物体上的图案的图像被拉伸。

108. 根据权利要求 106 或 107 的扫描器,其中光栅是闪耀光栅。

109. 根据前述任何一项权利要求的扫描器,其中探测光的发射点和反射光的收集点位于探头上,所述探头适合于进入腔内,例如体腔中。

110. 根据前一项权利要求的扫描器,其中探头适合于扫描腔中的一个或多个物体,例如口中的牙齿。

111. 根据权利要求 109 的扫描器,其中探头适合于扫描腔例如耳道的至少一部分表面。

112. 根据前述任何一项权利要求的扫描器,包括:

- a) 容纳照相机、图案产生装置,焦点变化装置和数据处理装置的外壳,和
- b) 容纳第一光学系统的至少一个探头。

113. 根据前一项权利要求的扫描器,其中外壳包括第二光学系统。

114. 根据权利要求 112 或 113 中任何一项的扫描器,其中探头是内窥的。

115. 根据权利要求 112 到 114 中任何一项的扫描器,其中探头包括至少一个光学纤维和 / 或纤维束,用于传输探测光和 / 或来自物体表面的反射光。

116. 根据权利要求 112 到 115 中任何一项的扫描器,其中探头能够从外壳上分离。
117. 根据权利要求 112 到 116 中任何一项的扫描器,其中探头是刚性的或柔性的。
118. 根据权利要求 112 到 117 中任何一项的扫描器,其中探测光的发射点和反射光的收集点位于探头上。
119. 根据权利要求 112 到 118 中任何一项的扫描器,其中探测光的第一发射点和反射光的第一收集点位于探头上,并且探测光的第二发射点和反射光的第二收集点位于外壳上。
120. 根据权利要求 112 到 119 中任何一项的扫描器,其中以基本上平行于光轴和/或探头纵轴的方向将探测光导向物体。
121. 根据权利要求 112 到 120 中任何一项的扫描器,其中探头包括后部的反射元件,例如镜子,或棱镜,用于沿不同于光轴的方向,优选地沿垂直于探测轴的方向引导探测光。
122. 根据前一项权利要求的扫描器,进一步包括用于使反射元件优选地围绕基本上平行于光轴的轴线旋转的装置。
123. 根据权利要求 112 到 122 中任何一项的扫描器,其中探头适合于提供围绕光轴和/或探头纵轴的 360° 扫描,优选地不旋转探头和/或扫描器。
124. 根据权利要求 112 到 123 中任何一项的扫描器,其中多个不同的探头与外壳匹配。
125. 根据权利要求 112 到 124 中任何一项的扫描器,包括适合于扫描人耳内部的第一探头和适合于扫描所述人耳外部的第二探头。
126. 根据权利要求 112 到 125 中任何一项的扫描器,其中外壳适合于进行 3D 表面扫描。
127. 根据权利要求 112 到 126 中任何一项的扫描器,其中具有装配有探头的外壳适合于扫描人耳内部,并且具有分离探头的外壳适合于扫描所述人耳的外部。
128. 根据权利要求 112 到 127 中任何一项的扫描器,进一步包括用于归并和/或合成耳内部和外部的 3D 数据的装置,由此提供完整的人耳 3D 模型。
129. 根据前述任何一项权利要求的扫描器,其适合于印模扫描,例如牙印模和/或耳道印模扫描。
130. 根据前述任何一项权利要求的扫描器,其适合于口内扫描,即直接扫描口腔内的牙齿和周围软组织。
131. 根据前述任何一项权利要求的扫描器,适合于牙科应用,例如扫描牙印模、石膏模型、蜡咬模、假牙修复和基牙。
132. 根据前述任何一项权利要求的扫描器,其适合于皮肤学或化妆应用领域中皮肤的 3D 结构的扫描。
133. 根据前述任何一项权利要求的扫描器,其适合于扫描珠宝或整个珠宝或部分珠宝的蜡模型。
134. 根据前述任何一项权利要求的扫描器,其适合于工业部件的扫描和/或质量控制。
135. 根据前述任何一项权利要求的扫描器,其适合于提供时间分辨的 3D 扫描,例如运动工业部件的时间分辨 3D 扫描。
136. 根据前述任何一项权利要求的扫描器,其中扫描器适合于手持,并且其中扫描器

包括一个或多个内置的运动感测器,该运动感测器产生将至少两个局部扫描合成为物体表面的 3D 模型的数据,其中运动感测器的数据潜在地用作通过软件找出的最佳合成的第一推测。

137. 根据前述任何一项权利要求的扫描器,其中扫描器适合于手持,并且其中扫描器包括一个或多个内置的运动感测器,该运动感测器产生与关于扫描方法的某些软件的使用者界面相互作用的数据。

138. 一种用于获得和/或测量物体的至少一部分表面的 3D 几何形状的方法,所述方法包括下列步骤:

- 产生整合空间图案的探测光,
- 沿着光学系统的光轴将探测光向物体传输,由此用所述图案照明物体的至少一部分,
- 传输从物体返回到照相机的光的至少一部分,
- 改变图案在物体上的焦平面的位置,同时保持扫描器和物体的固定空间关系,
- 获得来自所述感测器元件阵列的至少一个图像,
- 在每个焦平面位置估计至少一个图像像素和加权函数之间的相关度,其中加权函数基于空间图案构形的信息确定;
- 通过分析相关度确定下列对象的准确对焦位置:
- 对于所述系列焦平面位置,在照相机中的多个图像像素的每个像素,或
- 对于所述系列焦平面,在照相机中的多个图像像素组的每个像素组,和
- 将准确对焦数据转换成 3D 真实世界坐标。

139. 一种包括程序编码装置的计算机编程产品,用于当所述程序编码装置在数据处理系统上执行时,使数据处理系统执行前述权利要求的方法。

140. 根据前一项权利要求的计算机编程产品,包括计算机可读介质,所述计算机可读介质具有储存在其上的程序编码装置。

141. 一种用于获得和/或测量物体的至少一部分表面的 3D 几何形状的扫描器,所述扫描器包括:

- 容纳感测器元件阵列的至少一个照相机,
 - 用于产生探测光的装置,
 - 用于将探测光向物体传输的装置,由此照明物体的至少一部分,
 - 用于传输从物体返回到照相机的光的装置,
 - 用于改变物体上的焦平面的位置的装置,
 - 用于从所述感测器元件阵列获得至少一个图像的装置,
 - 用于以下方面的装置:
 - a) 确定下列对象的准确对焦位置:
 - 对于一系列焦平面位置,多个感测器元件中的每一个,或
 - 对于一系列焦平面位置,多个感测器元件组中的每个组,和
 - b) 将准确对焦数据转换成 3D 真实世界坐标;
- 其中扫描器进一步包括配重装置以配衡改变焦平面位置的装置。

142. 一种用于获得和/或测量物体的至少一部分表面的 3D 几何形状的方法,所述方法包括下列步骤:

- 容纳感测器元件阵列,
- 产生探测光,
- 将探测光向物体传输,由此照明物体的至少一部分,
- 传输从物体返回到照相机的光,
- 改变物体上的焦平面的位置,
- 从所述感测器元件阵列获得至少一个图像,
- 确定下列对象的准确对焦位置:
 - 对于一系列焦平面位置,多个感测器元件中的每一个,或
 - 对于一系列焦平面位置,多个感测器元件组中的每个组,和
 - 将准确对焦数据转换成 3D 真实世界坐标;

其中该方法进一步包括配准改变焦平面位置的装置。

143. 一种手持式 3D 扫描器,其手柄与扫描器的主光轴呈大于 30 度的角,以用于口内或耳内扫描。

聚焦扫描设备

技术领域

[0001] 本发明涉及一种用于表面的光学 3D 扫描的装置和方法。本发明的装置和方法的原理可以在各种环境中应用。本发明的一个具体实施例特别适合于口内扫描，即直接扫描口腔内的牙齿及周围的软组织。本发明的其他关于牙齿的实施例适合于扫描牙印模、石膏模型、蜡咬模、假牙修复和基牙，本发明的另一个实施例适合于扫描人耳或耳道印模的内部和外部部分。本发明可能发现了在皮肤病学或美容/整容应用中的皮肤 3D 结构的扫描、珠宝或整个珠宝或珠宝的一部分的蜡模的扫描、工业零件的扫描和平均时间分辨的 3D 扫描（例如运动的工业零件的时间分辨 3D 扫描）的用途。

背景技术

[0002] 本发明涉及物体表面几何形状的三维 (3D) 扫描。在 3 个维度上扫描物体表面是众所周知的研究领域并且用于扫描的方法可分成接触和非接触方法。接触测量方法的实例是坐标测量机 (CMM)，其通过让接触探头追踪表面来进行测量。优点包括精确度很高，但过程慢并且 CMM 大且昂贵。非接触测量方法包括 x 射线和光学探头。

[0003] 共焦显微镜方法是一种光学成像技术，其用来增大显微照片对比度和 / 或通过利用空间针孔重建三维图像以消除比焦平面厚的样品中的离焦光或光斑。

[0004] 共焦显微镜利用探测器前面的光学共轭面中的针孔和点照明以消除离焦信息。仅仅焦平面内的光能被检测到。由于在共焦显微术中每次仅仅照亮一个点，所以 2D 成像需要光栅扫描，3D 成像需要在一系列焦平面内的光栅扫描。

[0005] 在 WO 00/08415 中，通过用多个照明光点照亮表面来应用共焦显微术的原理。通过改变焦平面，能确定表面的准确对焦特定光点的位置。然而，表面构造的确定局限于被光点照亮的表面部分。

[0006] WO 2003/060587 涉及显微术中样本的光学分割，其中用照明图案照亮样本。通过表征图案的振荡分量来确定图像平面的焦点位置。然而，仅仅能通过使样本和光学系统相对于彼此移动，即使得它们彼此靠近或远离，来调节焦平面。因而，焦平面的受控震动要求在样本和光学系统之间有受控的空间关系，该空间关系在显微镜中被满足。然而，这种受控的空间关系不适宜于例如手持式扫描器。

[0007] US 2007/0109559A1 描述了一种聚焦扫描器，其中由聚焦透镜的位置找出距离，在聚焦透镜的所述位置上观察到入射到被扫描物体上的光束的最大反射强度。与本文公开的发明对比，该现有技术没有采用照明图案的预定测量，并且没有采用对比度检测，因此信噪比不是最佳。

[0008] 在 WO2008/125605 中，描述了用于产生时变图案的装置，该图案由交替的双像构成。该文献描述了一种借助两个不同的照明分布，例如相反相位的两个图案获得扫描物体的光学切面的扫描方法。这两个图像用来提取光学切面，而且该方法局限于从仅仅两个不同的照明分布来获得图像。此外，该方法依赖于确定两个照明分布之间的相位偏移的预定校准。

发明内容

[0009] 因此,本发明的一个目的是提供可以整合到易管理的外壳,例如手持外壳中的扫描器。本发明的又一个目的是:区分离焦的信息并且提供快速的扫描时间。

[0010] 这通过用于获得和/或测量物体的至少一部分表面的3D几何形状的一种方法和扫描器而实现,所述扫描器包括:

[0011] -至少一个容纳感测器元件阵列的照相机,

[0012] -用于产生整合空间图案的探测光的装置,

[0013] -用于将探测光向物体传输的装置,从而利用一种或多种构形的所述

[0014] 图案照明物体的至少一部分,

[0015] -用于传输从物体返回到照相机的光的至少一部分的装置,

[0016] -用于改变物体上的图案的焦平面的位置,同时保持扫描器与物体的固定空间关系的装置,

[0017] -用于从所述感测器元件阵列获得至少一个图像的装置,

[0018] -用于在每个焦平面位置估计至少一个图像像素和加权函数之间的相关度的装置,其中加权函数基于空间图案的构形信息而确定,

[0019] -数据处理装置,用于:

[0020] a) 通过相关度的分析确定下列对象的准确对焦位置:

[0021] -对于一系列焦平面位置,多个图像像素中的每一个,

[0022] -对于一系列焦平面位置,多个图像像素组中的每个组,和

[0023] b) 将准确对焦数据转换成3D真实世界坐标。

[0024] 本发明中描述的方法和设备用光作为非接触性的探测媒介提供物体的3D表面登记。将光提供为一种照明图案的形式从而在物体上提供光振荡。图案的变化/振荡可以是空间的,例如静止的棋盘图案,和/或其可以是时变的,例如通过使图案移动经过被扫描的物体。本发明提供一系列焦平面位置上的图案的焦平面的变化,同时保持扫描器和物体的固定空间关系。这并不表示必须在扫描器和物体具有固定空间关系的情况下提供扫描,而只是表示在扫描器和物体具有固定空间关系的情况下焦平面可以被改变(扫描)。这提供了基于本发明的手持式扫描器方案。

[0025] 在一些实施例中,来自感测器元件阵列的信号是光强度。

[0026] 本发明的一个实施例包括第一光学系统,例如透镜的布置,用于将探测光向物体传输,和第二光学系统,用于使从物体返回到照相机的光成像。在本发明的优选实施例中,仅仅一个光学系统优选地沿着相同的光轴,然而沿着相反的光路,将图案成像到物体上并将物体或物体的至少一部分成像到照相机上。

[0027] 在本发明的优选实施例中,光学系统将图案成像到被探测的物体上并将被探测的物体成像到照相机。优选地,以这样的方式调整焦平面,图案在被探测物体上的图像沿着光轴移动,优选以等步幅从扫描区域的一端移动到另一端。包括图案的探测光在物体上提供明与暗的图案。具体来说,对于固定焦平面当图案随时间变化时,物体上的准确对焦区域将显示明与暗的振荡图案。离焦区域在光振荡中将显示较小对比度或没有对比度。

[0028] 通常我们考虑入射到物体上的光从物体的表面发生漫反射和/或镜面反射的情

况。但是应当理解扫描装置和方法不限于这种情况。它们还可适用于例如入射光穿透表面并反射和/或散射和/或在物体中引起荧光和/或磷光的情况。在足够半透明的物体中的内表面也可以被照明图案照明并且成像到照相机上。在这种情况下体积扫描是可能的。一些浮游生物是这种物体的实例。

[0029] 当应用时变图案时,可以通过在焦平面的不同位置和以图案的不同实例收集大量 2D 图像来获得单个扫描。当焦平面在单个像素位置处与扫描表面相重合时,图案将会被投影到准确对焦并具有高对比度的表面点上,由此引起像素值随时间的大的变化或振幅。因此可以对于每个像素识别聚焦平面的单独设置,对于聚焦平面每个像素都是准确对焦的。通过利用所使用的光学系统的了解,可以在单个像素的基础上将对比度信息-焦平面位置转换成 3D 表面信息。

[0030] 因此在本发明的一个实施例中,通过对一系列焦平面确定多个感测器元件中的每一个的光振荡幅度来计算焦点位置。

[0031] 对于静止图案,可以通过在焦平面的不同位置收集大量 2D 图像而获得单个扫描。当焦平面与扫描表面重合时,图案将会被投影到准确对焦并具有高对比度的表面点上。高对比度在物体的表面上引起静止图案的大空间变化,由此在一组相邻的像素上提供像素值的大的变化或振幅。因此可以对每一组像素识别聚焦平面的单独设置,对于聚焦平面每组像素都是准确对焦的。通过利用所使用的光学系统的了解,可以在单个像素组的基础上将对比度信息-焦平面位置转换成 3D 表面信息。

[0032] 因此在本发明的一个实施例中,通过对一系列焦平面确定多组感测器元件中的每一组的光振荡幅度来计算焦点位置。

[0033] 图像数据的 2D 到 3D 的转换可以通过本领域中已知的大量方式进行。即,被探测物体的 3D 表面结构可以通过当记录一系列不同焦平面的光振幅时,找到对应于照相机感测器阵列中的每个感测器元件或每组感测器元件的最大光振荡幅度的平面而确定。优选地,以等步幅从扫描区域的一端到另一端调节焦平面。优选地,焦平面可以在足够大的范围中移动从而至少与被扫描物体的表面重合。

[0034] 本发明本身区别于 WO 2008/125605,因为在本发明的使用时变图案的实施例中,输入图像不限于两种照明分布,而是可以由图案的任何照明分布获得。这是因为参考图像的定向不完全依赖于预定校准,而是依赖于输入图像获得的具体时间。

[0035] 因此 WO 2008/125605 具体应用了正好两种图案,其通过从任一侧照明的镀铬玻璃遮盖件而在物理上实现,其中背面是反光的。因此 WO2008/125605 具有不使用移动部件的优点,但缺点是信噪比较差。在本发明中具有使用任何数量的图案构形的可能性,这使光振荡幅度或相关度的计算更加精确。

[0036] 定义:

[0037] 图案:包括嵌入在侧平面中的空间结构的光信号。也可以称为“照明图案”。

[0038] 时变图案:随时间变化的图案,即,嵌入的空间结构随时间变化。也可以称为“时变的照明图案”。以下也称为“条纹 (fringe)”。

[0039] 静止图案:不随时间变化的图案,例如,静止的棋盘图案或静止的线图案。

[0040] 图案构形:图案的状态。在某一时间对图案构形的了解等于知道在该时间的照明的空间结构。对于周期性图案而言,图案构形将包括图案相位的信息。如果被扫描物体的

表面元素被成像到照相机上,那么对图案构形的了解等于知道图案的哪个部分照明该表面元素。

[0041] 焦平面:从图案发射的光线会聚到其上以在被扫描的物体上形成图像的表面。焦平面不必是平面,其可以为曲面。

[0042] 光学系统:光学组件的布置,例如传输、校准和/或使光成像的透镜,例如将探测光朝物体传输,将图案成像在物体上或物体内部,并将物体或物体的至少一部分成像在照相机上。

[0043] 光轴:由光束的传播确定的轴。光轴优选为直线。在本发明的优选实施例中,光轴由多个光学组件的构形确定,例如光学系统中透镜的构形。光轴可以多于一个,例如如果一个光学系统将探测光传输到物体上,而另一个光学系统将物体成像到照相机上。但优选地,光轴将由图案传输到物体上和将物体成像到照相机的光学系统中的光传播来确定。光轴通常与扫描器的纵轴重合。

[0044] 光路:由光源到照相机的光传播所确定的路径。因此,优选一部分光路与光轴重合。然而优选光轴为直线,光路可以是非直线的,例如当例如借助分束器、镜子、光导纤维等等使光被反射、散射、弯曲、拆分等等时。

[0045] 焦阑系统:一种光学系统,其以主光线平行于所述光学系统的光轴的方式提供成像。在焦阑系统中,离焦点具有与准确对焦点基本上相同的放大率。这可以在数据处理中提供优势。完美的焦阑光学系统是难以达到的,然而基本上或接近焦阑的光学系统可以通过细致的光学设计而提供。因此,当指出焦阑光学系统时,应当理解为其可能仅仅是接近焦阑的。

[0046] 扫描长度:视域的横向尺寸。如果探头顶端(即扫描头)包括折光光学器件(folding optics),以沿不同方向例如垂直于光轴的方向引导探测光,那么扫描长度是平行于光轴的横向尺寸。

[0047] 扫描物体:被扫描的物体,并且扫描器在其表面上提供信息。“扫描物体”可以只是被称为“物体”。

[0048] 照相机:成像感测器,包括对应于输入到成像感测器上的光的多个感测器。优选感测器以行和列的2D阵列排序。

[0049] 输入信号:来自照相机中感测器的光输入信号或感测器输入信号。这可以在感测器的积分或者曝光时间内入射到感测器上的光积分强度。一般而言,其转换为图像中的像素值。也可被称为“感测器信号”。

[0050] 参考信号:源自于图案的信号。参考信号也可以表示为加权函数或加权向量或参考向量。

[0051] 相关度:参考信号和输入信号之间相关程度的量度。相关度优选地如此定义:如果参考信号和输入信号是彼此线性相关的,那么与两者非线性相关相比,相关度获得更大的量值。

[0052] 在某些情况下,相关度是光振荡幅度。

[0053] 图像:图像可被视为值的2D阵列(当用数码相机获得图像时),或者在光学器件中,图像表示在成像表面和图像表面之间存在关联,其中由所述成像表面上的一点发出的光线基本上会聚到所述图像表面上的一点上。

[0064] 强度：在光学器件中，强度是对每单位面积的光能的量度。在用包括多个单独感测元件的照相机记录的图像中，强度可以用于表示在单独感测元件上记录的光信号。在这种情况下，强度反映了在图像记录所涉及的曝光时间中在感测元件上每单位面积的光能对时间的积分。

[0065] 数学符号

[0066] A 在加权函数和记录的光信号之间的相关度。这可以是光振荡幅度。

[0067] I 光输入信号或感测器输入信号。这可以在感测器的积分或曝光时间内入射到感测器上的光积分强度。一般而言，其转化为图像中的像素值。

[0068] f 参考信号。也可以被称为加权值。

[0069] n 用一个和 / 或几个照相机感测器进行的、用于计算相关度的测量数量。

[0070] H 用像素数量表示的图像高度。

[0071] W 用像素数量表示的图像宽度。

[0072] 在正文中也根据需要对符号进行了解释。

[0073] 本发明的详细描述

[0074] 扫描器优选地包括位于光路上的至少一个分束器。例如可以借助分束器将物体的图像形成在照相机中。分束器的示例性使用在附图中示出。

[0075] 在本发明的优选实施例中，光在包括透镜系统的光学系统中传输。该透镜系统可以将图案向物体传输，并且使从物体反射的光成像到照相机。

[0076] 在焦阑光学系统中，离焦点具有与准确对焦点相同的放大率。焦阑投影因此可以显著地简化所获得的 2D 图像向 3D 图像的数据映射。因此，在本发明的优选实施例中，光学系统在被探测物体的空间中是基本上焦阑的。光学系统在图案和照相机的空间中也可以是焦阑的。

[0077] 变焦

[0078] 本发明的关键点是在扫描器相对于被扫描物体不发生移动的情况下的焦平面的变化，即扫描。优选地，焦平面可以变化，例如以周期的方式连续变化，而图案产生装置、照相机、光学系统和被扫描的物体相对于彼此固定。此外，3D 表面获得时间应当足够小以降低探头和齿之间的相对运动的影响，例如减小震动的影响。在本发明的优选实施例中，借助至少一个聚焦元件改变焦平面。优选地，焦平面以预定频率周期性地变化。所述频率可以是至少 1Hz，例如至少 2Hz、3、4、5、6、7、8、9 或至少 10Hz，例如至少 20、40、60、80 或至少 100Hz。

[0079] 优选地，聚焦元件是光学系统的一部分。即，聚焦元件可以是透镜系统中的透镜。优选的实施例包括装置，例如平移台，用于调节和控制聚焦元件的位置。由此焦平面可被改变，例如通过使聚焦元件沿着光轴前后平移。

[0080] 如果聚焦元件以几 Hz 的频率前后平移，则这可能导致扫描器的不稳定。因此本发明的优选实施例包括用于减小和 / 或消除来自聚焦元件调节系统的震动和 / 或晃动的装置，由此提高扫描器的稳定性。这可至少部分地通过用于固定和 / 或保持聚焦元件调节系统的质量中心的装置来提供，例如基本上配重聚焦元件的移动的配重，举例来说，通过与聚焦元件的移动相反地平移配重。如果配重和聚焦元件相连并且借助相同的平移装置驱动，则可以容易地实现操作。然而这仅仅基本上可以将震动降低到一阶。如果配重平衡装置围绕配重平衡轴旋转，则可能有关于配重产生转矩的问题。因此，本发明的又一个实施例包括

用于减小和/或消除来自聚焦元件调节系统的一阶、二阶、三阶和/或更高阶振动和/或晃动的装置,由此提高扫描器的稳定性。

[0071] 在本发明的另一个实施例中,移动多于一个的光学元件以使焦平面移动。在这个实施例中,希望这些元件一起移动并且希望这些元件是物理上相邻的。

[0072] 在本发明的优选实施例中,光学系统对于所有的焦平面位置是焦阑的或接近焦阑的。因此,即使光学系统中的一个或多个透镜可以前后移动以改变焦平面位置,但是光学系统的焦阑度得到维持。

[0073] 本发明的优选实施例包括焦传动(focus gearing)。焦传动是透镜移动和焦平面位置的移动之间的相关性。例如,焦传动为2表示聚焦元件平移1mm对应于焦平面位置平移2mm。可以通过对光学系统的合适设计提供焦传动。焦传动的优势在于聚焦元件的少量移动可对应于焦平面位置的大的改变。在本发明的具体实施例中,焦传动在0.1和100之间,例如在0.1和1之间,例如在1和10之间,例如在2和8之间,例如在3和6之间,例如至少10,例如至少20。

[0074] 在本发明的另一实施例中,聚焦元件是液体透镜。液体透镜可以控制焦平面而不使用任何移动部件。

[0075] 照相机

[0076] 照相机可以是配备标准CCD或CMOS芯片的标准数码相机,每排感测器元件(像素)具有一个A/D转换器。然而,为了提高帧频,根据本发明的扫描器可以包括每排像素配备多个A/D转换器的高速照相机,例如每排像素配备至少2、4、8或16个A/D转换器。

[0077] 图案

[0078] 本发明的另一个核心元素是具有投影到被扫描物体上的嵌入图案的探测光。该图案可以是静止的或是时变的。时变图案可以在物体上和/或物体内部提供明与暗的变化。具体来讲,当对于固定焦平面图案随时间变化时,物体上的准确对焦区域将显示明与暗的振荡图案。离焦区域将在光振荡中显示较小对比度或没有对比度。静止图案可以在物体上和/或物体内部提供明与暗的空间变化。具体来说,准确对焦区域将显示在空间中明与暗的振荡图案。离焦区域将在空间光振荡中显示较小对比度或没有对比度。

[0079] 可以由外部光源提供光,然而优选地,扫描器包括至少一个光源和图案产生装置以产生图案。设计光源以使得图案的未遮盖部分的强度在空间上尽可能地接近均匀,这在信噪比方面是有利的。在另一个实施例中,光源和图案产生装置整合在单个组件中,例如分段LED。分段LED可以提供静止图案和/或它本身可以通过顺次打开和关闭不同的段来提供时变图案。在本发明的一个实施例中,时变图案随时间周期性地变化。在本发明的另一个实施例中,静止图案在空间上周期性地变化。

[0080] 来自光源(内部或外部的)的光可以通过图案产生装置传输,由此产生图案。例如图案产生装置包括至少一个半透明和/或透明的图案元件。为了产生时变图案,可以使用具有不透明遮盖件的轮。例如遮盖件包括优选地以对称的顺序布置的多个径向辐条。扫描器也可以包括用于使图案元件旋转和/或平移的装置。为了产生静止图案,可以使用具有不透明遮盖件的玻璃板。例如遮盖件包括线图案或棋盘图案。一般来说,所述遮盖件优选地拥有旋转和/或平移的周期性。图案元件位于光路中。因此,来自光源的光可以通过图案元件传输,例如,通过图案元件横向传输。从而可以通过旋转和/或平移图案元件产生

时变图案。产生静止图案的图案元件在扫描过程中不必移动。

[0081] 相关性

[0082] 本发明的一个目的是提供短的扫描时间和实时处理,例如为扫描器操作者提供现场反馈以对整个齿弧进行快速扫描。然而,实时高分辨率 3D 扫描产生庞大的数据量。因此应当在扫描器外壳中,即靠近光学组件,提供数据处理,以降低向例如车、工作站或显示器的数据传输速率。为了加快数据处理时间和为了提取具有最佳信噪比的准确对焦信息,可以嵌入/执行各种相关技术,这例如可以在照相机电子设备中执行以区分离焦信息。应用图案以在被扫描的物体上提供具有嵌入的空间结构的照明。确定准确对焦信息与计算在这种空间结构的光信号(我们称为输入信号)和图案本身的变化(我们称为参考信号)之间的相关度有关。通常,如果输入信号与参考信号相符,相关度的量值高。如果输入信号显示小的变化或无变化,那么相关度的量值低。如果输入信号显示大的空间变化但是这种变化不同于参考信号的变化,那么相关度的量值也低。在本发明的又一个实施例中,扫描器和/或扫描头可以是无线的,由此简化扫描器的处理和操作并且在困难的扫描情况下提高可接近性,例如在口内或耳中的扫描。然而,无线操作可进一步增加对本地数据处理的需要以避免原始 3D 数据的无线传输。

[0083] 参考信号由图案产生装置提供并且可以是周期性的。输入信号的变化可以是周期性的,并且其可以被限制成一个或几个周期。参考信号可以与输入信号无关地确定。具体而言,在周期性变化的情况下,可与输入信号无关地知悉振荡输入和参考信号之间的相位。在周期性变化的情况下,相关性典型地与变化幅度相关。如果振荡输入和参考信号之间的相位不是已知的,则需要输入信号的变化幅度可被确定之前,确定输入信号的余弦和正弦部分。当相位已知时,这不是必需的。

[0084] 以数学方式用一套不连续的测量值确定相关度的一种方式是由以下向量计算的点积,信号向量, $I = (I_1, \dots, I_n)$, 其中 $n > 1$ 元素代表感测器信号,和参考向量, $f = (f_1, \dots, f_n)$, 具有与参考加权的所述信号向量相同的长度。因而由下式给出相关度 A:

$$[0085] \quad A = f \cdot I = \sum_{i=1}^n f_i I_i$$

[0086] 信号向量中元素的下标表示在不同时间和/或在不同感测器记录的感测器信号。在连续测量的情况下,上述表达式被容易地概括为涉及积分而不是求和。在这种情况下积分参数是时间和/或一个或多个空间坐标。

[0087] 优选的实施例是当参考向量元素和为零($\sum_i f_i = 0$)时,除去相关信号或相关度的 DC 部分。焦点位置可以作为在所有聚焦元件位置上计算的相关度的极值而被找出。我们注意到,在这种情况下,相关度与两个变量之间的样本皮尔森相关系数成比例。如果没有除去 DC 部分,在所有聚焦元件位置上可存在 DC 信号的趋势,并且这种趋势在数值上可以是主导性的。在这种情况下,仍然可以通过分析相关度和/或其导数中的一个或多个找到焦点位置,优选地在除去趋势以后。

[0088] 优选地,应当找到总极值。然而,人为因素例如在光学系统上的污物可导致错误的全局最大值。因此,在某些情况下,找出局部极值可能是明智的。如果被扫描的物体足够半透明,可能可以识别内表面或表面部分,否则内表面或表面部分会被遮蔽。在这种情况下,可能有几个对应于表面的局部极值,并且处理几个或所有极值可能是有利的。

[0089] 相关度典型地可以基于输入信号进行计算,输入信号可作为数码图像(即具有有限数量的不连续像素的图像)而被获得。因此,便利地,可以对图像像素或其像素组进行用于获得相关度的计算。因此相关度可以被形象化为伪图像。

[0090] 在本发明中应用的相关度受锁相放大器的原理启发,其中输入信号与参考信号相乘并且在特定时间上积分。在本发明中,参考信号由图案提供。

[0091] 时间相关性

[0092] 时间相关性涉及时变图案。当图案构形变化时,照相机中的单独光感测元件中的光信号被记录了几次。因而,至少用以不同次数记录的感测器信号计算相关度。

[0093] 在WO 98/45745中教导了估计在周期性变化光信号中的光振荡幅度的原理,其中通过首先估计光强度振荡的余弦和正弦部分来计算幅度。然而,由统计学的观点来说,这不是最佳方法,因为为了能够计算幅度估计了两个参数。

[0094] 在本发明的这个实施例中,独立地了解在每个光信号记录的图案构形使得能够计算在每个光感测元件的相关度。

[0095] 在本发明的某些实施例中,扫描器包括用于获得图案构形的了解的装置。为了提供这种了解,扫描器优选地进一步包括用于登记和/或监测时变图案的装置。

[0096] 在照相机中每个单独的光感测元件,即感测器元件,都感测到光信号的变化,该变化对应于用于照明物体的光的变化。

[0097] 本发明的一个实施例通过平移和/或旋转图案元件获得图案的时间变化性。在这种情况下,可以借助图案元件上的位置编码器结合对图案几何形状的预先了解获得图案构形,该图案几何形状引起横跨单独感测元件的图案变化。因此对图案构形的了解作为以下两者的结合而产生:对导致横跨不同感测元件的变化的图案几何形状的了解,和在3D扫描过程中的图案登记和/或监测。因而在旋转作为图案元件的轮的情况下,可以通过例如安装在轮圈上的编码器获得轮的角位置。

[0098] 本发明的一个实施例涉及具有平移和/或旋转周期性的图案。在这个实施例中,如果图案基本上以恒定速度平移和/或旋转,则有明确的图案振荡周期。

[0099] 本发明的一个实施例包括在一个图案振荡周期过程中对多个感测器元件中的每一个进行多次取样的装置,优选地在每个图案振荡周期过程中取样整数次,例如取样2、3、4、5、6、7或8次,由此确定在周期内的光变化。

[0100] 在光变化和图案之间的时间相关度可以通过在一个振荡周期(或至少一个振荡周期)过程中在照相机上记录几个图像获得。在一个振荡周期过程中记录的图像数量被表示为n。与在所有感测元件上独立了解的图案变化(即获得对图案构形的了解)以及记录的图像相结合的对于每个单独图像的图案位置登记使得能够有效提取照相机中的每个单独感测元件中的相关度。对于具有标识j的光感测元件,该元件的n个被记录的光信号表示为 $I_{1,j}, \dots, I_{n,j}$ 。该元件的相关度 A_j 可以表达为:

$$[0101] \quad A_j = \sum_{i=1}^n f_{i,j} I_{i,j}$$

[0102] 在这里,参考信号或加权函数f由对图案构形的了解获得。f具有两个下标i,j。f随着第一个下标的变化来源于在每个图像记录过程中对图案位置的了解。f随着第二个下标的变化来源于对图案几何形状的了解,图案几何形状可以在3D扫描之前确定。

[0103] 优选地,但并不一定,参考信号 f 在时间上平均为零,即对于所有的 i 我们具有:

$$[0104] \quad \sum_{i=1}^n f_i = 0$$

[0105] 以抑制相关度或光变化的 DC 部分。当焦点位置在一组值上变化时,对于照相机中的单个感测器元件而言与准确对焦于物体上的图案对应的焦点位置将通过该感测器元件的相关度极值而给出。焦点位置能以等步幅从扫描区域的一端到另一端变化。

[0106] 为了借助照相机获得物体的清晰图像,物体必须被准确对焦,而且在照相机的图像感测器的曝光期间照相机光学器件与物体必须处于固定的空间关系中。对于本发明而言,这意味着图案和焦点应当以不连续的步幅发生变化,从而能够对照相机中取样的每个图像固定图案和焦点,即,在感测器阵列的曝光时间内进行固定。然而,为了增加图像数据的敏感度,感测器阵列的曝光时间应当与感测器帧频容许的一样高。因此,在本发明的优选实施例中,在图案连续变化(例如通过连续旋转图案轮)并且焦平面连续移动时在照相机中记录(取样)图像。这意味着单独的图像将会有轻微模糊,因为它们是在图案正在变化并且焦平面发生移动时图像的时间积分的结果。能预料到这会导致数据质量变劣,但是在实践中图案和焦平面同时变化的优点大于缺点。

[0107] 在本发明的另一个实施例中,当图案固定且焦平面连续移动,即图案不移动时,在照相机中记录(取样)图像。当光源是分段光源时,例如以适当的方式闪光的分段 LED,可能是这种情况。在这个实施例中,通过结合以下两点的组合来获得图案的了解:对分段 LED 上多个单独段的几何形状的预先了解,该几何形状产生横跨光感测元件的变化,和在每个记录对 LED 的不同段施加的电流。

[0108] 在本发明的又一个实施例中,当图案连续变化且焦平面固定时在照相机中记录(取样)图像。

[0109] 在本发明的又一个实施例中,当图案和焦平面都固定时在照相机中记录(取样)图像。

[0110] 时间相关性原理一般可以应用在图像分析中。因此,本发明的又一个实施例涉及一种用于计算在至少一个(光电)光敏元件中光强度振荡幅度的方法,所述光强度振荡由周期性变化的照明图案产生,并且所述幅度在至少一个图案振荡周期中计算,所述方法包括下列步骤:

[0111] - 在图案振荡周期中对下列对象提供预定数量的取样次数;

[0112] o 对光敏元件取样由此提供所述光敏元件的信号,和

[0113] o 对所述取样提供周期性变化照明图案的角位置和 / 或相位,和

[0114] - 通过在所述预定数量的取样次数上对预定周期函数与相应光敏元件信号的乘积求积分来计算所述(多个)幅度,其中所述周期函数是周期性变化照明图案的角位置和 / 或相位的函数。

[0115] 这也可以表达为:

$$[0116] \quad A = \sum_i f(p_i) I_i$$

[0117] 其中 A 是计算的幅度或相关度, i 是对每个取样的下标, f 是周期函数, p_i 是对于取样 i 的照明图案的角位置 / 相位,和 I_i 是对于取样 i 的光敏元件的信号。优选地,周期函数在图案振荡周期上平均为零,即:

$$[0118] \quad \sum_j f(\rho_j) = 0$$

[0119] 为了将该原理推广到例如在探测器阵列中的多个光敏元件,对于具体光敏元件的照明图案的角位置/相位可由与照明图案关联的角位置/相位加上与具体光敏元件相关联的恒定补偿组成。由此,光敏元件 j 中的光振荡幅度或相关度可以表达为:

$$[0120] \quad A_j = \sum_j f(\theta_j + p_j) U_{i,j}$$

[0121] 其中 θ_j 是对光敏元件 j 的恒定补偿。

[0122] 可以通过具有不透明遮盖件的旋转轮产生周期性变化的照明图案,该不透明遮盖件包括以对称顺序布置的多个径向辐条。由此,轮的角位置将对应于图案的角位置,并且该角位置可以通过安装在轮的轮圈上的编码器获得。对于不同图案位置横跨不同探测器元件的图案变化可以在 3D 扫描之前在校准程序中确定。对该图案变化和图案位置的了解的组合构成了对图案构形的了解。该图案的周期例如可以是两个辐条之间的时间,并且该周期的单个或多个光敏元件的幅度可以通过在这个周期中取样例如四次来计算。

[0123] 周期性变化的照明图案可以通过与该线正交的伦奇刻线移动而产生,并且位置由编码器测量。该位置对应于所产生的图案的角位置。作为选择,可以使用棋盘图案。

[0124] 周期性变化的照明图案可以通过多个 LED 的一维阵列产生,该多个 LED 可以以线方式控制。

[0125] 变化的照明图案可以通过基于 LCD 或 DLP 的投影器产生。

[0126] 光学相关性

[0127] 上述相关性原理(时间相关性)要求对时变图案的某种登记,例如了解记录在照相机中的每个光水平的图案构形。然而在本发明的另一个实施例中,可以提供没有这种登记的相关性原理。该原理称为“光学相关性”。

[0128] 在本发明的这个实施例中,图案本身的图像和利用投影到其上的图案扫描的物体的至少一部分的图像在照相机上结合。即照相机上的图像是图案本身和利用投影到其上的图像探测的物体两者的叠加。表达这一点的不同方式是,照相机上的图像基本上是投影到物体上的图案的图像乘以图案本身。

[0129] 这可以通过以下方式提供。在本发明的又一个实施例中,图案产生装置包括具有不透明遮盖件的透明图案元件。探测光通过图案元件传输,优选地通过图案元件横向传输。由被扫描物体返回的光以相反路线传输通过所述图案元件并且在照相机上成像。这优选以如下方式完成,照明物体的图案的图像和图案本身的图像在两者都成像到照相机上时重合。图案的特别实例是具有不透明遮盖件的旋转轮,遮盖件包括以对称顺序布置的多个径向辐条,以使得图案具有旋转周期性。在这个实施例中,如果图案基本上以恒定速度旋转,则有明确的图案振荡周期。我们将振荡周期定义为 $2\pi/\omega$ 。

[0130] 我们指出,在本发明的所述实施例中,照明图案是明与暗的图案。具有标识 j 的照相机中的光感测元件在照相机积分时间 δt 内具有与积分光强度成比例的信号 I_j , I_j 由下式给出:

$$[0131] \quad I_j = K \int_{t_0}^{t_0 + \delta t} T_j(t) S_j(t) dt$$

[0132] 这里, K 是感测器信号的比例常数, t 是照相机积分时间的开始, T_j 是成像到第 j 个

光感测元件上的旋转图案元件部分的时变传输,而 S_j 是由被扫描物体返回并且成像到第 j 个光感测元件上的光的时变光强度。在所述的实施例中, T_j 是基本上如下定义的阶跃函数: 对于 $\sin(\omega t + \phi_j) > 0$ 时 $T_j(t) = 0$, 而在其它时候 $T_j(t) = 1$ 。 ϕ_j 是取决于第 j 个成像感测器的位置的相位。

[0133] 光感测元件上的信号是图案和由被扫描物体返回的光的相关度。时变传输起到参考信号的作用,且由被扫描物体返回的光的时变光强度起到输入信号的作用。本发明这个实施例的优点是:具有强度感测元件的普通 CCD 或 CMOS 照相机可以直接用于记录相关度,因为其表现为感测元件上的强度。表达这一点的另一种方式是:相关度的计算发生在模拟的光学领域中而不是在电子领域例如 FPGA 或 PC 中。

[0134] 因而,当焦点位置在一组值上变化时,对于照相机中的单个感测器元件,对应于在被扫描物体上准确对焦的图案的焦点位置因而将由该感测器元件记录的相关度的最大值给出。焦点位置可以由扫描区域的一端到另一端以等步幅变化。本发明的一个实施例包括用于在一系列焦平面位置上记录和/或积分和/或监测和/或储存多个感测器元件中的每一个的装置。优选地,应当找到全局最大值。然而,人为因素例如在光学系统上的污物可导致错误的全局最大值。因此,在某些情况下,找出局部最大值可能是明智的。

[0135] 由于参考信号不是平均为零,所以相关度具有 DC 分量。由于没有除去 DC 部分,所以在所有聚焦元件位置上可能存在 DC 信号的趋势,并且这种趋势在数值上可以是主导性的。在这种情况下,仍然可以通过分析相关度和/或其导数中的一个或多个找到焦点位置。

[0136] 在本发明的又一个实施例中,照相机积分时间是图案振荡周期的整数 M , 即 $\delta t = 2\pi M/\omega$ 。这个实施例的一个优点是:与照相机积分时间不是图案振荡周期的整数相比,可在有噪音的情况下测得具有更佳信噪比的相关度量值。

[0137] 在本发明的又一个实施例中,照相机积分时间比图案振荡周期长得多,即 $\delta t \gg 2\pi M/\omega$ 。许多倍的图案振荡时间在这里意味着例如照相机积分时间是振荡时间的至少 10 倍,或者更优选地例如是振荡时间的至少 100 或 1000 倍。该实施例的一个优点是:不需要照相机积分时间和图案振荡时间的同步,这是因为对于与图案振荡时间相比非常长的照相机积分时间而言,记录的相关度与准确的同步基本上无关。

[0138] 等同于时间相关性原理,光学相关性原理可一般地应用于图像分析中。因此,本发明的又一个实施例涉及在至少一个(光电)光敏元件中计算光强度振荡幅度的方法,所述光强度振荡通过变化的照明图案和图案本身的叠加而产生,且所述幅度通过在多个图案振荡周期上对来自于所述至少一个光敏元件的信号进行时间积分而计算。

[0139] 空间相关性

[0140] 上述相关性原理(时间相关性和光学相关性)要求图案随时间变化。如果光学系统和照相机提供扫描物体所需的至少两倍的横向分辨率,则可能采用静止图案扫描,即不随时间变化的图案。该原理称为“空间相关性”。因此至少利用在不同感测器地点记录的感测器信号计算相关度。

[0141] 光学系统的横向分辨率应当理解为光学系统例如透镜系统中光学元件的如下性能:将空间频率成像到被扫描物体上直到某一程度。光学系统的调制传递曲线典型地用于描述在光学系统中空间频率的成像。例如,某人可以将光学系统的分辨率定义为在调制传递曲线降低到例如 50% 的情况下被扫描物体上的空间频率。照相机的分辨率是单独的照相

机感测器元件的间隔与光学系统的分辨率的结合效果。

[0142] 在空间相关性中,相关度是指发生在空间上而不是时间上的输入信号和参考信号之间的相关性。因此,在本发明的一个实施例中,测量的3D几何形状的分辨率等于照相机的分辨率。然而,对于空间相关性,测量的3D几何形状的分辨率低于照相机的分辨率,例如低至少2倍,例如低至少3倍,例如低至少4倍,例如低至少5倍,例如低至少10倍。感测器元件阵列优选地被拆分为多个感测器元件组,优选为矩形组,例如感测器元件的正方形组,优选地相邻的感测器元件的正方形组。因而,扫描的分辨率,即测量的3D几何形状的分辨率,将通过这些感测器元件组的大小而确定。在这些感测器元件组内提供光信号的振荡,然后通过分析感测器元件组获得光振荡的幅度。优选地,在数据处理阶段中将感测器元件阵列拆分为组,即该拆分不是物理的拆分,从而可能要求特别适配的感测器阵列。因此,拆分为组是“虚拟的”,即使组中的单个像素是实际的物理像素。

[0143] 在本发明的一个实施例中,图案沿着至少一个空间坐标具有平移周期。在本发明的又一个实施例中,空间周期图案与感测器元件阵列的行和/或列对齐。例如,在静止线图案的情况下,照相机中像素的行或列可与图案的线平行。或者在静止棋盘图案的情况下,棋盘的行和列可分别与照相机中像素的行和列对齐。对齐表示图案在照相机上的图像与照相机的感测器阵列中的感测器元件的“图案”对齐。因此,图案产生装置和照相机的某种物理定位和取向要求扫描器的光学组件的某种构形以使图案与照相机的感测器阵列对齐。

[0144] 在本发明的又一个实施例中,图案的至少一个空间周期对应于一组感测器元件。在本发明的又一个实施例中,所有的感测器元件组包括相同数量的元件并且具有相同的形状,例如,当棋盘图案的周期对应于照相机上的例如 2×2 、 3×3 、 4×4 、 5×5 、 6×6 、 7×7 、 8×8 、 9×9 、 10×10 或更多像素的正方形组时。

[0145] 在另一个实施例中,图案的一个或多个边与感测器元件阵列的一个或多个边对齐和/或重合。例如棋盘图案可以与照相机像素以如下方式对齐:棋盘图案在照相机上的图像的边与像素的边重合。

[0146] 在空间相关性中,对图案构形的独立了解使得能够计算每组光感测的相关度。对于空间周期性照明,可以计算这种相关度而不必估计光强度振荡的余弦和正弦部分。对图案构形的了解可以在3D扫描之前获得。

[0147] 在本发明的又一个实施例中,在具有标识 j 的一组感测器元件内,相关度 A_j 借助下列公式确定:

$$[0148] \quad A_j = \sum_{i=1}^n f_{i,j} I_{i,j}$$

[0149] 其中, n 是一组感测器中的感测器元件的数量, $f_j = (f_{1,j}, \dots, f_{n,j})$ 是由了解图案构形获得的参考信号向量, $I_j = (I_{1,j}, \dots, I_{n,j})$ 是输入信号向量。对于在具有 N 个感测器作为正方形长度的正方形区域中分组感测器的情况,则 $n = N^2$ 。

[0150] 优选,但并不一定,参考信号向量的元素在空间上平均为零,即对于所有的 j ,我们具有:

$$[0151] \quad \sum_{i=1}^n f_{i,j} = 0$$

[0152] 以抑制相关度的DC部分。当焦点位置在一组值上变化时,对于照相机中的单组感

测器元件,对应于在物体上准确对焦的图案的焦点位置将通过该感测器元件组的相关度极值给出。焦点位置可以从扫描区域的一端到另一端以等步幅变化。

[0153] 在如下静止棋盘图案的情况下,其边与照相机像素对齐并且与具有偶数个像素如 $2 \times 2, 4 \times 4, 6 \times 6, 8 \times 8, 10 \times 10$ 的像素组对齐,则对参考向量 f 的自然选择将是:对于成像为棋盘的明亮正方形的像素,向量元素取值为 1,对于成像为棋盘的黑暗正方形的像素,取值为 -1。

[0154] 等同于其它相关性原理,空间相关性原理一般可应用于图像分析中。特别是在照相机的分辨率高于最终图像所必须的情况下。因此,本发明的又一个实施例涉及在至少一个光敏元件组中计算光强度振荡的(多个)幅度的方法,所述光强度振荡通过空间变化的静止照明图案产生,所述方法包括下列步骤:

[0155] ~ 在所述光敏元件组中提供来自于每个光敏元件的信号,和

[0156] ~ 通过在所述光敏元件组上对预定函数和来自于相应光敏元件的信号的乘积进行积分来计算所述(多个)幅度,其中所述预定函数是反映照明图案的函数。

[0157] 为了将该原理推广到例如在感测器阵列中的多个光敏元件上,在组 j 中的光振荡幅度或相关度可以表示为:

$$[0158] \quad A_j = \sum_{i=1}^n f(i, j) I_{i,j}$$

[0159] 其中, n 是组 j 中的感测器元件数量, $I_{i,j}$ 是来自于组 j 中第 i 个感测器元件的信号,和 $f(i, j)$ 是反映图案的预定函数。

[0160] 与时间相关性相比,空间相关性具有不需要移动图案的优点。这意味着对图案构形的了解可在 3D 扫描之前获得。相反,时间相关性的优点是其更高的分辨率,因为不需要像素分组。

[0161] 当用容许非常高的帧频的图像感测器实现时,所有的相关性原理都能够实现运动中物体的 3D 扫描而几乎没有移动模糊。随时间跟踪移动物体(“4D 扫描”)也变得可能,这例如在机器视觉和动态变形测量中是有用的应用。在本文中,非常高的帧频是至少 500,但优选至少 2000 帧每秒。将相关度极值转换为 3D 世界坐标

[0162] 可以由通过光学系统的光线跟踪而将识别的照相机感测器或照相机感测器组的焦点位置关联到 3D 世界坐标中。在能够进行这种光线跟踪之前,需要了解光学系统的参数。本发明的一个实施例包括校准步骤以获得这种了解。本发明的又一个实施例包括如下校准步骤:其中对于多个焦点位置记录具有已知几何形状的物体的图像。该物体可以是平面棋盘图案。然后,可以通过产生模拟的校准物体的光线跟踪图像,然后调节光学系统参数以使模拟图像和记录图像之间的差别最小化来校准扫描器。

[0163] 在本发明的又一个实施例中,校准步骤要求对于几个不同校准物体的多个焦点位置和/或几个不同取向和/或一个校准物体的多个位置记录图像。

[0164] 当了解了光学系统的参数,某人可以采用后向光线跟踪技术来估计 2D \rightarrow 3D 的映射。这要求了解扫描器的光学系统,优选地通过校准。可以进行下列步骤:

[0165] 1. 由(在图像感测器上的)图像的每个像素,跟踪某个数量的光线,所述光线由图像感测器开始并且通过光学系统(后向光线跟踪)。

[0166] 2. 由发射出的光线,计算焦点,即所有这些光线基本上交叉的点。该点代表 2D 像

素将会准确对焦的 3D 坐标,即,产生光振荡幅度的全局最大值。

[0167] 3. 对所有像素及其相应的 3D 坐标产生查阅表。

[0168] 上述步骤在覆盖扫描器操作范围的大量不同聚焦透镜位置上重复。

[0169] 镜面反射

[0170] 通常需要在物体上的准确对焦图案图像的高空间对比度以获得照相机上的相关度的良好信噪比。因而可能需要获得对应于相关度极值的焦点位置的良好估计。通常在具有漫反射面和可忽略的透光性的物体中容易获得成功扫描的该充足信噪比。然而,对于一些物体而言,难以获得高空间对比度。

[0171] 例如,一种困难的物体是一种具有如下特征的物体:其显示出入射光的多次散射,该入射光的光漫射长度与成像到物体上的空间图案的最小特征尺寸相比大。人的牙齿就是这种物体的实例。人的耳朵和耳道是其他实例。在口腔内扫描的情况下,优选地应当在不需向牙齿喷射和/或干燥牙齿以降低镜面反射和透光性的情况下提供扫描。可以通过从物体到照相机上的镜面反射的优先成像获得改进的空间对比度。因此,本发明的一个实施例包括对镜面反射光和/或漫反射光优先/选择成像的装置。如果扫描器进一步包括使探测光偏振的装置,则这可以例如借助至少一个偏振光束分光器来提供。例如可以提供偏振光束分光器以在照相机中形成物体的图像。这可用于消除镜面反射,因为如果入射光是线性地偏振的,则来自物体的镜面反射具有保持其偏振状态的性质。

[0172] 根据本发明的扫描器可进一步包括改变探测光和/或从物体反射的光的偏振状态的装置。这可以借助优选地位于光路中的延迟板而提供。在本发明的一个实施例中,延迟板是四分之一波长的延迟板。线偏振光波在通过四分之一波长板时被转换为圆偏振光波,其中四分之一波长板的快轴相对线偏振方向的取向为 45 度。这可以用来增强镜面反射,因为来自物体的镜面反射具有下列性质:它翻转圆偏振光波的螺旋性,而由一个或多个散射事件反射的光被去偏振。

[0173] 视域(扫描长度)

[0174] 在本发明的一个实施例中,以基本上平行于光轴的方向将探测光向物体传输。然而,对于进入小空间例如患者口腔的扫描头,需要扫描头的顶端足够小。同时,出自扫描头的光需要以不同于光轴的方向离开扫描头。因此,本发明的又一个实施例包括用于将探测光导入不同于光轴的方向和/或使物体成像的装置。这可以借助优选地沿光轴布置的至少一个折光元件来提供。折光元件用于将探测光导入不同于光轴的方向和/或使物体成像。折光元件可以是光反射元件,例如镜子或棱镜。在本发明的一个实施例中,45 度的镜子用作折光光学器件以将光路引导到物体上。由此沿垂直于光轴的方向引导探测光。在这个实施例中,扫描顶端的高度至少与扫描长度一样大,并且优选具有大约相等的尺寸。

[0175] 本发明的一个实施例包括至少两个光源,例如具有不同波长和/或不同偏振的光源。优选地还有用于控制所述至少两个光源的控制装置。优选地,该实施例包括用于合并和/或归并来自所述至少两个光源的光的装置。优选地,还有用于分离来自于所述至少两个光源的光的装置。如果使用波导光源,则它们可以通过波导归并。然而,也可以提供一个或多个漫射体以归并光源。

[0176] 可以通过部分光传输和部分光反射的至少一个光学设备提供分离和/或归并,所述光学设备优选沿光轴布置,光学设备例如是有涂层的镜子或有涂层的板。一个实施例包

括至少两个所述光学设备,所述光学设备优选沿光轴移动,优选地,至少一个所述光学设备传输处于某些波长和/或偏振的光而反射处于其它波长和/或偏振的光。

[0177] 本发明的一个示例性实施例包括至少第一和第二光源,所述光源具有不同的波长和/或偏振,和其中

[0178] 第一光学设备以不同于光轴的方向反射来自于所述第一光源的光并且传输来自于所述第二光源的光,和

[0179] 第二光学设备以不同于光轴的方向反射来自于所述第二光源的光,优选地,所述第一和第二光学设备以平行方向,优选以垂直于光轴的方向,反射探测光,由此使物体表面的不同部分成像。所述物体表面的不同部分可以是至少部分重叠的。

[0180] 因此,例如使用适当涂层的板将来自于发射不同波长(和/或偏振)的光的第一和第二光源的光归并到一起,该适当涂层的板传输来自于第一光源的光并反射来自于第二光源的光。在沿着光轴的扫描顶端,第一光学设备(例如适当涂层的板,二向色滤光片)将来自于第一光源的光反射到物体上,并且将来自于第二光源的光传输到在扫描顶端末尾,即光轴更后端位置的第二光学设备(例如镜子)上。在扫描过程中,使焦点位置移动以使来自第一光源的光用于将图案的图像投影到第一光学设备下方的位置,同时第二光源关闭。记录第一光学设备下方区域中物体的3D表面。然后,第一光源关闭而第二光源打开,并且使焦点位置移动以使来自第二光源的光用于将图案的图像投影到第二光学设备下方的位置。记录第二光学设备下方区域中的物体的3D表面。由分别来自两个光源的光所覆盖的区域可部分重叠。

[0181] 在本发明的另一个实施例中,借助弯曲的折光镜将探测光导入不同于光轴的方向。这个实施例可包括一个或多个光学元件,例如透镜,其具有非球面的表面以提供修正的光学成像。

[0182] 本发明的又一个实施例包括用于使(多个)镜子沿光轴平移的至少一个平移台。这容许扫描顶端的高度小于扫描长度。通过将几个扫描与沿着光轴处于不同位置的(多个)镜子合并可以获得大扫描长度。

[0183] 在本发明的另一个实施例中,借助至少一个光栅将探测光导入不同于光轴的方向,该光栅提供失真的放大以使图案在被扫描物体上的图像受到拉伸。光栅可以是闪耀光栅。在这个实施例中,光源需要为单色的或半单色的。

[0184] 上述适合增加扫描长度的实施例可包括用于提供光源和聚焦元件的配合的控制装置。

[0185] 彩色扫描

[0186] 本发明的一个实施例仅仅是登记被扫描物体的表面拓扑结构(几何形状)。然而,本发明的另一个实施例适于获得被扫描表面的颜色,即能够登记被扫描物体的单独表面元素的颜色以及被扫描物体的表面拓扑结构。为了获得颜色信息,光源需要为白色的或者包括至少三个单色光源,其具有分布在电磁波谱的可见部分上的颜色。

[0187] 为了提供颜色信息,感测器元件的阵列可以是彩色图像感测器。图像感测器可以配有 Bayer 滤色片方案,然而,可以提供其它的彩色图像感测器类型,例如 Foveon 类型的彩色图像感测器,其中图像感测器在每个感测器元件中提供颜色的登记。

[0188] 本发明的一个实施例包括每次选择探测光的一种颜色的装置,即在探测光的不同