

UNITED STATES PATENT AND TRADEMARK OFFICE

BEFORE THE PATENT TRIAL AND APPEAL BOARD

ALIGN TECHNOLOGY, INC.,
Petitioner,

v.

3SHAPE A/S,
Patent Owner.

Case PGR2018-00104
Patent 9,962,244 B2

Before SALLY C. MEDLEY, IRVIN E. BRANCH, and
JESSICA C. KAISER, *Administrative Patent Judges*.

BRANCH, *Administrative Patent Judge*.

DECISION
Denying Institution of Post-Grant Review
35 U.S.C. § 324 and 37 C.F.R. § 41.208

Align Technology, Inc. (“Petitioner”) filed a Petition pursuant to 35 U.S.C. §§ 321–329 requesting a post-grant review of claims 31, 32, and 34 of U.S. Patent No. 9,962,244 B2, issued on May 8, 2018 (Ex. 1001, “the ’244 patent”). Paper 2 (“Pet.”). 3Shape A/S (“Patent Owner”) filed a Preliminary Response. Paper 6 (“Prelim. Resp.”). Applying the standard set forth in 35 U.S.C. § 324(a), which requires demonstration that it is more likely than not that at least 1 of the claims challenged in the petition is unpatentable, we deny Petitioner’s request and do not institute a post-grant review of any challenged claim.

I. BACKGROUND

A. *The ’244 Patent (Ex. 1001)*

The ’244 patent, titled “Focus Scanning Apparatus Recording Color,” issued on May 8, 2018. Ex. 1001, at [45], [54]. The ’244 patent describes a scanning system and method to generate a digital three-dimensional (3D) representation of an object that has been scanned. *Id.* at 1:6–9, 2:5–13. The scanning system generates the digital 3D representation based on surface geometry and surface color derived from a series of captured two-dimensional (2D) images of the object. *Id.* at 1:64–2:13. Figure 1 of the ’244 patent illustrates an exemplary scanner system and associated components and is reproduced below.

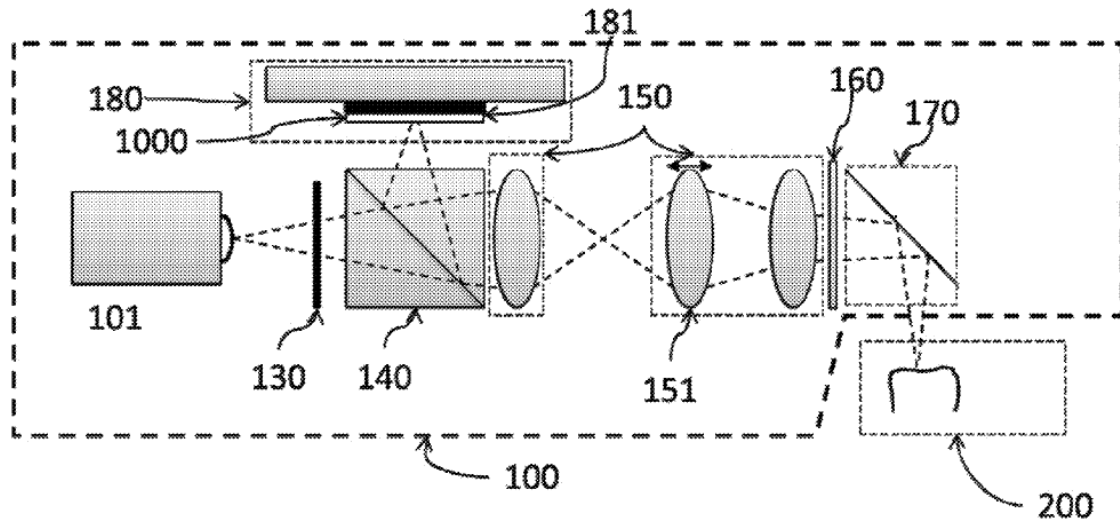

Figure 1 depicts a handheld embodiment of a scanner used to perform intraoral scanning. Ex. 1001, 15:63–64.

As shown in Figure 1, the scanner system includes a multichromatic light source 101, which can be a multi-die LED with green, red, and blue dies. *Id.* at 15:63–66, 16:36–37. The light from the light source travels through optical system 150 and illuminates the object to be scanned 200, e.g., a tooth. *Id.* at 16:4–6, 17:65–66. Color image sensor 180 and associated image sensor 181 capture a 2D image of the illuminated object 200. *Id.* at 16:1–9. The image sensor comprises pixels, which capture the images. *See id.* at 16:52–56. The system captures additional 2D images of the object 200 at different focal imaging planes by shifting a focusing element 151, e.g., a lens, back and forth, thereby capturing a series of 2D images of the object 200 at each focal plane position. *Id.* at 16:14–18, 18:4–7, 65–67; *see id.* at Fig. 6A.

Using one or more of the captured 2D images, the system derives both surface geometry information and surface color information for a block of image sensor pixels. *Id.* at 16:52–56, 18:8–10. To determine surface geometry information, first, a correlation measure is determined using 2D

images in the series of 2D images; based on those correlation measures, a correlation measure function is determined. *Id.* at 18:24–26, 33–37, 19:6–11; *see id.* at Fig. 6B. That correlation measure function has a maximum. *Id.* at 19:8–11; *see id.* at Fig. 6B. That maximum is then used to derive surface geometry information. *Id.* at 19:12–15. Accordingly, because the correlation measure function maximum is based on 2D images in the series of 2D images, the derived surface geometry information is based on 2D images in the series of 2D images.

Further, surface color information for the block of pixels is derived from the same 2D images from which surface geometry information was derived. *Id.* at 2:48–59, 19:37–29; *see id.* at Fig. 6C. In particular, surface color information is derived from the same 2D images that were previously used to determine the correlation measure function maximum for deriving surface geometry information. *Id.* at 18:41–47. For example, the color values of two 2D images which previously were used to determine the correlation measure function maximum are averaged to determine surface color information for the block of pixels. *Id.* at 19:21–29; *see id.* Figs. 6A–6C.

The derived surface geometry information and derived surface color information are used to generate sub-scans, i.e., portions of the digital 3D model. *Id.* at 18:8–15. Those sub-scans are combined to generate a digital 3D representation of the object. *Id.* at 10:45–50, 18:16–20.

B. Illustrative Claims

Claims 31, 32, and 34 are independent claims and are reproduced below.

31. A focus scanner for recording surface geometry and surface color of an object, the focus scanner comprising:

a multichromatic light source configured for providing a multichromatic probe light for illumination of the object,

a color image sensor comprising an array of image sensor pixels for capturing one or more 2D images of light received from said object, where the color image sensor comprises a color filter array comprising at least three types of colors filters, each allowing light in a known wavelength range, W1, W2, and W3 respectively, to propagate through the color filter;

wherein the focus scanner is configured to operate by translating a focus plane along an optical axis of the focus scanner and capturing a series of the 2D images, each 2D image of the series is at a different focus plane position such that the series of captured 2D images forms a stack of 2D images; and

a data processing system configured to derive surface geometry information for a block of said image sensor pixels from the 2D images in the stack of 2D images captured by said color image sensor, the data processing system also configured to derive surface color information for the block of said image sensor pixels from at least one of the 2D images used to derive the surface geometry information,

where the data processing system further is configured to derive the surface geometry information is derived from light in a selected wavelength range of the spectrum provided by the multichromatic light source, and where the color filter array is such that its proportion of pixels with color filters that match the selected wavelength range of the spectrum is larger than 50 %.

32. A focus scanner for recording surface geometry and surface color of an object, the focus scanner comprising:

a multichromatic light source configured for providing multichromatic probe light for illumination of the object,

a color image sensor comprising an array of image sensor pixels for capturing one or more 2D images of light received from said object,

Explore Litigation Insights

Docket Alarm provides insights to develop a more informed litigation strategy and the peace of mind of knowing you're on top of things.

Real-Time Litigation Alerts



Keep your litigation team up-to-date with **real-time alerts** and advanced team management tools built for the enterprise, all while greatly reducing PACER spend.

Our comprehensive service means we can handle Federal, State, and Administrative courts across the country.

Advanced Docket Research



With over 230 million records, Docket Alarm's cloud-native docket research platform finds what other services can't. Coverage includes Federal, State, plus PTAB, TTAB, ITC and NLRB decisions, all in one place.

Identify arguments that have been successful in the past with full text, pinpoint searching. Link to case law cited within any court document via Fastcase.

Analytics At Your Fingertips



Learn what happened the last time a particular judge, opposing counsel or company faced cases similar to yours.

Advanced out-of-the-box PTAB and TTAB analytics are always at your fingertips.

API

Docket Alarm offers a powerful API (application programming interface) to developers that want to integrate case filings into their apps.

LAW FIRMS

Build custom dashboards for your attorneys and clients with live data direct from the court.

Automate many repetitive legal tasks like conflict checks, document management, and marketing.

FINANCIAL INSTITUTIONS

Litigation and bankruptcy checks for companies and debtors.

E-DISCOVERY AND LEGAL VENDORS

Sync your system to PACER to automate legal marketing.