

TRANSMITTAL LETTER TO THE UNITED STATES DESIGNATED/ELECTED OFFICE (DO/EO/US) CONCERNING A SUBMISSION UNDER 35 U.S.C. 371		ATTORNEY DOCKET NO. 0079124-000111
		U.S. APPLICATION NO. (If known) Unassigned
INTERNATIONAL APPLICATION NO. PCT/EP2014/052842	INTERNATIONAL FILING DATE 13 February 2014	PRIORITY DATE CLAIMED 13 February 2013
TITLE OF INVENTION FOCUS SCANNING APPARATUS RECORDING COLOR		
FIRST NAMED INVENTOR Bo ESBECH et al.		
<p>Applicant herewith submits to the United States Designated/Elected Office (DO/EO/US) the following items and other information.</p> <p>1. <input type="checkbox"/> This is an express request to begin national examination procedures (35 U.S.C. 371(f)). NOTE: The express request under 35 U.S.C. 371(f) will not be effective unless the requirements under 35 U.S.C. 371(c)(1), (2), and (4) for payment of the basic national fee, copy of the International Application and English translation thereof (if required), and the oath or declaration of the inventor(s) have been received.</p> <p>2. <input type="checkbox"/> A copy of the International Application (35 U.S.C. 371(c)(2)) is attached hereto (not required if the International Application was previously communicated by the International Bureau or was filed in the United States Receiving Office (RO/US)).</p> <p>3. An English language translation of the International Application (35 U.S.C. 371(c)(2))</p> <p>a. <input checked="" type="checkbox"/> is attached hereto.</p> <p>b. <input type="checkbox"/> has been previously submitted under 35 U.S.C. 154(d)(4).</p> <p>4. An oath or declaration of the inventor(s) (35 U.S.C. 371(c)(4))</p> <p>a. <input type="checkbox"/> is attached.</p> <p>b. <input type="checkbox"/> was previously filed in the international phase under PCT Rule 4.17(iv).</p> <p>Items 5 to 8 below concern amendments made in the international phase.</p> <p><u>PCT Article 19 and 34 amendments</u></p> <p>5. <input type="checkbox"/> Amendments to the claims under PCT Article 19 are attached (not required if communicated by the International Bureau) (35 U.S.C. 371(c)(3)).</p> <p>6. <input type="checkbox"/> English translation of the PCT Article 19 amendment is attached (35 U.S.C. 371(c)(3)).</p> <p>7. <input type="checkbox"/> English translation of annexes (Article 19 and/or 34 amendments only) of the International Preliminary Examination Report is attached (35 U.S.C. 371(c)(5)).</p> <p><u>Cancellation of amendments made in the international phase</u></p> <p>8a. <input type="checkbox"/> Do not enter the amendment made in the international phase under PCT Article 19.</p> <p>8b. <input type="checkbox"/> Do not enter the amendment made in the international phase under PCT Article 34.</p> <p>NOTE: A proper amendment made in English under Article 19 or 34 will be entered in the U.S. national phase application absent a clear instruction from applicant not to enter the amendment(s).</p> <p>The following items 9 to 17 concern a document(s) or information included.</p> <p>9. <input checked="" type="checkbox"/> An Information Disclosure Statement under 37 CFR 1.97 and 1.98.</p> <p>10. <input checked="" type="checkbox"/> A preliminary amendment</p> <p>11. <input checked="" type="checkbox"/> An Application Data Sheet under 37 CFR 1.76.</p> <p>12. <input type="checkbox"/> A substitute specification. NOTE: A substitute specification cannot include claims. See 37 CFR 1.125(b).</p> <p>13. <input type="checkbox"/> A power of attorney and/or change of address letter.</p> <p>14. <input type="checkbox"/> A computer-readable form of the sequence listing in accordance with PCT Rule 13ter.3 and 37 CFR 1.821-1.825.</p> <p>15. <input type="checkbox"/> Assignment papers (cover sheet and document(s)). Name of Assignee : 3Shape A/S.</p> <p>16. <input type="checkbox"/> 37 CFR 3.73(c) Statement (when there is an Assignee).</p>		

U.S. APPLICATION NO. (If known) Unassigned	INTERNATIONAL APPLICATION NO. PCT/EP2014/052842	ATTORNEY DOCKET NO. 0079124-000111
---	--	---------------------------------------

17. Other items or information:

General Authorization for Petitions for Extensions of Time and Payment of Fees
Form PCT/IB/301
Form PCT/IB/304
Form PCT/IB/308 (First Notice)
Form PCT/IB/308 (Second Notice)
Form PCT/ISA/210

The following fees have been submitted.				CALCULATIONSPTO USE ONLY	
18. <input checked="" type="checkbox"/>	Basic national fee (37 CFR 1.492(a))	(1631)	\$280	\$	280.00
19. <input checked="" type="checkbox"/>	Examination fee (37 CFR 1.492(c)) If the written opinion prepared by ISA/US or the International preliminary examination report prepared by IPEA/US indicates all claims satisfy provisions of PCT Article 33(1)-(4)	(1643)	\$0	\$	720.00
	All other situations.....	(1633)	\$720		
20. <input checked="" type="checkbox"/>	Search fee (37 CFR 1.492(b)) If the written opinion prepared by ISA/US or the International preliminary examination report prepared by IPEA/US indicates all claims satisfy provisions of PCT Article 33(1)-(4)	(1640)	\$0		
	Search fee (37 CFR 1.445(a)(2)) has been paid on the international application to the USPTO as an International Searching Authority.....	(1641)	\$120		
	International Search Report prepared by an ISA other than the US and provided to the Office or previously communicated to the US by the IB.....	(1642)	\$480		
	All other situations.....	(1632)	\$600	\$	480.00
TOTAL OF 18, 19 and 20 =				\$	1,480.00
<input type="checkbox"/> Additional fee for specification and drawings filed in paper over 100 sheets (excluding sequence listing in compliance with 37 CFR 1.821(c) or (e) in an electronic medium or computer program listing in an electronic medium) (37 CFR 1.492(j)). Fee for each additional 50 sheets of paper or fraction thereof				(1681)	\$400
Total Sheets		Extra sheets	Number of each additional 50 or fraction thereof (round up to a whole number)	RATE	
- 100 =		/ 50 =		x \$400	\$
Surcharge of \$140.00 for furnishing any of the search fee, examination fee, or the oath or declaration after the date of commencement of the national stage (37 CFR 1.492(h)).				\$	140.00
CLAIMS		NUMBER FILED	NUMBER EXTRA	RATE	
Total claims		31 - 20 =	11	x \$80 (1615)	\$ 880.00
Independent Claims		2 - 3 =		x \$420 (1614)	\$
MULTIPLE DEPENDENT CLAIM(S) (if applicable)				+ \$780 (1616)	\$
Processing fee of \$140.00 (1618) for furnishing the English translation later than 30 months from the earliest claimed priority date (37 CFR 1.492(i)).				+	\$
TOTAL OF ABOVE CALCULATIONS =				\$	2,500.00
<input type="checkbox"/> Applicant asserts small entity status. See 37 CFR 1.27. Fees above are reduced by 1/2.					
<input type="checkbox"/> Applicant certifies micro entity status. See 37 CFR 1.29. Fees above are reduced by 1/4. Applicant must attach form PTO/SB/15A or B or equivalent.					
TOTAL NATIONAL FEE =				\$	2,500.00
Fee for recording the enclosed assignment (37 CFR 1.21(h)). The assignment must be accompanied by an appropriate cover sheet (37 CFR 3.28, 3.31). \$40.00 per property				+	\$
TOTAL FEES ENCLOSED =				\$	2,500.00
				Amount to be refunded:	
				Amount to be charged:	

- a. A check in the amount of \$__ to cover the above fees is enclosed.
- b. Please charge my Deposit Account No. 02-4800 in the amount of \$__ to cover the above fees.
- c. The Director is hereby authorized to charge additional fees which may be required, or credit any overpayment, to Deposit Account No. 02-4800 as follows:
- i. any required fee
- ii. any required fee except for excess claims fees required under 37 CFR 1.492(d) and (e) and multiple dependent claim fee required under 37 CFR 1.492(f).
- d. Fees are to be charged to a credit card. **WARNING:** Information on this form may become public. Credit card information should not be included on this form. Provide credit card information and authorization on PTO-2038. The PTO-2038 should only be mailed or faxed to the USPTO. However, when paying the basic national fee, the PTO-2038 may NOT be faxed to the USPTO.

ADVISORY: If filing by EFS-Web, do NOT attach the PTO-2038 form as a PDF along with your EFS-Web submission. Please be advised that this is not recommended and by doing so your credit card information may be displayed via PAIR. To protect your information, it is recommended to pay fees online by using the electronic payment method.

NOTE: Where an appropriate time limit under 37 CFR 1.495 has not been met, a petition to revive (37 CFR 1.137(a) or (b)) must be filed and granted to restore the International Application to pending status.

Statement under 37 CFR 1.55 or 1.78 for AIA (First Inventor to File) Transition Applications

This application (1) claims priority to or the benefit of an application filed before March 16, 2013, and (2) also contains, or contained at any time, a claim to a claimed invention that has an effective filing date on or after March 16, 2013.

NOTE 1: By providing this statement under 37 CFR 1.55 or 1.78, this application, with a filing date on or after March 16, 2013, will be examined under the first inventor to file provisions of the AIA.

NOTE 2: A U.S. national stage application may not claim priority to the international application of which it is the national phase. The filing date of a U.S. national stage application is the international filing date. See 35 U.S.C. 363

Correspondence Address

The address associated with Customer Number 21839 OR Correspondence address below

Name	Buchanan Ingersoll & Rooney PC				
Address	P.O. Box 1404				
City	Alexandria	State	VA	Zip Code	22313-1404
Country	USA			Telephone	(703) 836-6620
Email					

Signature		Date	July 28, 2015
Name (Print/Type)	Travis D. Boone	Registration No. (Attorney/Agent)	52635

IN THE UNITED STATES PATENT AND TRADEMARK OFFICE

In re Patent Application of)	
Bo ESBECH et al.)	Group Art Unit: Unassigned
Application No.: Unassigned)	Confirmation No.: Unassigned
Filed: July 28, 2015)	
For: FOCUS SCANNING APPARATUS)	
RECORDING COLOR)	
)	
)	

**GENERAL AUTHORIZATION FOR PETITIONS
FOR EXTENSIONS OF TIME AND PAYMENT OF FEES**

Commissioner for Patents
P.O. Box 1450
Alexandria, VA 22313-1450

Commissioner:

In accordance with 37 C.F.R. § 1.136(a)(3), the U.S. Patent and Trademark Office is hereby provided with a general authorization to treat any concurrent or future reply requiring a petition for an extension of time for its timely submission as containing a request therefor for the appropriate length of time.

The Commissioner is hereby authorized to charge any appropriate fees that may be required by this paper, or any other submissions in this application, and to credit any overpayment, to Deposit Account No. 02-4800.

Respectfully submitted,

BUCHANAN INGERSOLL & ROONEY PC

Date: July 28, 2015

By: T.D. Boone
Travis D. Boone
Registration No. 52635

Customer Number 21839
703.836.6620

Under the Paperwork Reduction Act of 1995, no persons are required to respond to a collection of information unless it displays a valid OMB control number.

TRANSMITTAL FOR POWER OF ATTORNEY TO ONE OR MORE REGISTERED PRACTITIONERS

NOTE: This form is to be submitted with the Power of Attorney by Applicant form (PTO/AIA/82B or equivalent) to identify the application to which the Power of Attorney is directed, in accordance with 37 CFR 1.5. If the Power of Attorney by Applicant form is not accompanied by this transmittal form or an equivalent, the Power of Attorney will not be recognized in the application.

Application Number	Unassigned
Filing Date	July 28, 2015
First Named Inventor	Bo ESBECH et al.
Title	FOCUS SCANNING APPARATUS RECORDING COLOR
Art Unit	Unassigned
Examiner Name	Unassigned
Attorney Docket Number	0079124-000111

SIGNATURE of Applicant or Patent Practitioner

Signature	<i>SD. Boone</i>	Date	July 28, 2015
Name	Travis D. Boone	Telephone	(703) 836-6620
Registration Number	52635		

NOTE: This form must be signed in accordance with 37 CFR 1.33. See 37 CFR 1.4(d) for signature requirements and certifications.

*Total of ONE (1) form is submitted.

This collection of information is required by 37 CFR 1.31, 1.32 and 1.33. The information is required to obtain or retain a benefit by the public which is to file (and by the USPTO to process) an application. Confidentiality is governed by 35 U.S.C. 122 and 37 CFR 1.11 and 1.14. This collection is estimated to take 3 minutes to complete, including gathering, preparing, and submitting the completed application form to the USPTO. Time will vary depending upon the individual case. Any comments on the amount of time you require to complete this form and/or suggestions for reducing this burden, should be sent to the Chief Information Officer, U.S. Patent and Trademark Office, U.S. Department of Commerce, P.O. Box 1450, Alexandria, VA 22313-1450. DO NOT SEND FEES OR COMPLETED FORMS TO THIS ADDRESS. **SEND TO: Commissioner for Patents, P.O. Box 1450, Alexandria, VA 22313-1450.**

If you need assistance in completing the form, call 1-800-PTO-9199 and select option 2.

POWER OF ATTORNEY BY APPLICANT

I hereby revoke all previous powers of attorney given in the application identified in either the attached transmittal letter or the boxes below.

Application Number	Filing Date

(Note: The boxes above may be left blank if information is provided on form PTO/AIA/82A.)

I hereby appoint the Patent Practitioner(s) associated with the following Customer Number as my/our attorney(s) or agent(s), and to transact all business in the United States Patent and Trademark Office connected therewith for the application referenced in the attached transmittal letter (form PTO/AIA/82A) or identified above:

21839

OR

I hereby appoint Practitioner(s) named in the attached list (form PTO/AIA/82C) as my/our attorney(s) or agent(s), and to transact all business in the United States Patent and Trademark Office connected therewith for the patent application referenced in the attached transmittal letter (form PTO/AIA/82A) or identified above. (Note: Complete form PTO/AIA/82C.)

Please recognize or change the correspondence address for the application identified in the attached transmittal letter or the boxes above to:

The address associated with the above-mentioned Customer Number

OR

The address associated with Customer Number:

OR

Firm or Individual Name				
Address				
City	State	Zip		
Country				
Telephone	Email			

I am the Applicant (if the Applicant is a Juristic entity, list the Applicant name in the box):

3Shape A/S

- Inventor or Joint Inventor (title not required below)
- Legal Representative of a Deceased or Legally Incapacitated Inventor (title not required below)
- Assignee or Person to Whom the Inventor is Under an Obligation to Assign (provide signer's title if applicant is a Juristic entity)
- Person Who Otherwise Shows Sufficient Proprietary Interest (e.g., a petition under 37 CFR 1.48(b)(2) was granted in the application or is concurrently being filed with this document) (provide signer's title if applicant is a Juristic entity)

SIGNATURE of Applicant for Patent

The undersigned (whose title is supplied below) is authorized to act on behalf of the applicant (e.g., where the applicant is a Juristic entity).

Signature	Date (Optional)	March 4, 2014
Name	Nikolaus Wetchnann	
Title	CEO, 3Shape A/S	

NOTE: Signature - This form must be signed by the applicant in accordance with 37 CFR 1.33. See 37 CFR 1.4 for signature requirements and certifications. If more than one applicant, use multiple forms.

Total of _____ forms are submitted.

This collection of information is required by 37 CFR 1.131, 1.32, and 1.33. The information is required to obtain or retain a benefit by the public which is to file (and by the USPTO to process) an application. Confidentiality is governed by 35 U.S.C. 422 and 37 CFR 1.11 and 1.14. This collection is estimated to take 3 minutes to complete, including gathering, preparing, and submitting the completed application form to the USPTO. Time will vary depending upon the individual case. Any comments on the amount of time you require to complete this form and/or suggestions for reducing this burden, should be sent to the Chief Information Officer, U.S. Patent and Trademark Office, U.S. Department of Commerce, P.O. Box 1460, Alexandria, VA 22310-1460. DO NOT SEND FEES OR COMPLETED FORMS TO THIS ADDRESS. SEND TO: Commissioner for Patents, P.O. Box 1460, Alexandria, VA 22313-1460.

If you need assistance in completing the form, call 1-800-PTO-8199 and select option 2.

IN THE UNITED STATES PATENT AND TRADEMARK OFFICE

In re Patent Application of)	Group Art Unit: Unassigned
)	
Bo ESBECH et al.)	Confirmation No.: Unassigned
)	
Application No.: Unassigned)	
)	
Filed: July 28, 2015)	
)	
For: FOCUS SCANNING APPARATUS)	
RECORDING COLOR)	

PRELIMINARY AMENDMENT

Commissioner for Patents
P.O. Box 1450
Alexandria, VA 22313-1450

Commissioner:

Prior to examination of the above-captioned patent application, kindly amend the application as follows.

AMENDMENTS TO THE SPECIFICATION:

Please replace the original specification with the attached substitute specification.

Please find attached:

- Marked-Up Copy of substitute specification
- Clean Copy of substitute specification.

No new matter has been added.

AMENDMENTS TO THE CLAIMS:

The following listing of claims will replace all prior versions and listings of claims in this application.

LISTING OF CLAIMS:

1. (Currently Amended) A focus scanner system for recording surface geometry and surface color of an object, the focus scanner system comprising:

~~[[-]]~~ a multichromatic light source configured for providing a multichromatic probe light for illumination of the object,

~~[[-]]~~ a color image sensor comprising an array of image sensor pixels for capturing one or more 2D images of light received from said object, and

~~-a data processing system configured for deriving both surface geometry information and surface color information for a block of said image sensor pixels from a series of 2D image recorded by said color image sensor;~~

~~where the scanner system is a~~ wherein the focus scanner system is configured to operate ~~operating~~ by translating a focus plane along an optical axis of the focus scanner system and capturing a series of the 2D images, each 2D image of the series is at a different focus plane position ~~positions~~ such that each the series of captured 2D images forms a stack of 2D images; and

a data processing system configured to derive surface geometry information for a block of said image sensor pixels from the 2D images in the stack of 2D images captured by said color image sensor, the data processing system also configured to derive surface color information for the block of said image sensor pixels from at least one of the 2D images used to derive the surface geometry information.

2. (Currently Amended) The focus scanner ~~system~~ according to claim 1, wherein the data processing system is configured for generating a sub-scan of a part of the object surface based on surface geometry information and surface color information derived from a plurality of blocks of image sensor pixels.

3. (Currently Amended) The focus scanner ~~system~~ according to claim 1 ~~or~~ 2, wherein the data processing system is configured for combining a number of sub-scans to generate a digital 3D representation of the object.

4. (Currently Amended) The focus scanner ~~system~~ according to claim 1 ~~any of the preceding claims~~, where the scanner system comprises a pattern generating element configured for incorporating a spatial pattern in said probe light.

5. (Currently Amended) The focus scanner ~~system~~ according to claim 1 ~~any of the preceding claims~~, where deriving the surface geometry information and surface color information comprises calculating for several 2D images a correlation measure between the portion of the 2D image captured by said block of image sensor pixels and a weight function, where the weight function is determined based on information of the configuration of the spatial pattern.

6. (Currently Amended) The focus scanner ~~system~~ according to ~~the preceding claim~~ 5, wherein deriving the surface geometry information and the surface color information for a block of image sensor pixels comprises identifying the position along the optical axis at which the corresponding correlation measure has a maximum value.

7. (Currently Amended) The focus scanner system according to claim ~~7 or 8~~ 6, wherein generating a sub-scan comprises determining a correlation measure function describing the variation of the correlation measure along the optical axis for each block of image sensor pixels and identifying the position along the optical axis at which the correlation measure functions have their maximum value for the block.

8. (Currently Amended) The focus scanner system according to claim 7 ~~or 8~~, where the maximum correlation measure value is the highest calculated correlation measure value for the block of image sensor pixels and/or the highest maximum value of the correlation measure function for the block of image sensor pixels.

9. (Currently Amended) The focus scanner system according to claim 6 ~~any of claims 6 to 9~~, wherein the data processing system is configured for determining a sub-scan color for a point on a generated sub-scan based on the surface color information of the 2D image in the series in which the correlation measure has its maximum value for the corresponding block of image sensor pixels.

10. (Currently Amended) The focus scanner system according to ~~the preceding claim 9~~, wherein the data processing system is configured for deriving the sub-scan color for a point on a generated sub-scan based on the surface color information of the 2D images in the series in which the correlation measure has its maximum value for the corresponding block of image sensor pixels and on at least one additional 2D image, ~~such as a neighboring 2D image from the series of captured 2D images.~~

11. (Currently Amended) The focus scanner system according to the ~~preceding claim~~ 10, where the data processing system is configured for interpolating surface color information of at least two 2D images in a series when determining the sub-scan color, such as an interpolation of surface color information of neighboring 2D images in a series.

12. (Currently Amended) The focus scanner system according to claim 10 ~~any of claims 10 to 14~~, wherein the data processing system is configured for computing an averaged sub-scan color for a number of points of the sub-scan, where the computing comprises an averaging of sub-scan colors of different points, ~~such as a weighted averaging of the colors of the surrounding points on the sub-scan.~~

13. (Currently Amended) The focus scanner system according to claim 1 ~~any of the preceding claims~~, where the data processing system is configured for determining object color for a least one point of the generated digital 3D representation of the object from sub-scan color of the sub-scans combined to generate the digital 3D representation, such that the digital 3D representation expresses both geometry and color profile of the object.

14. (Currently Amended) The focus scanner system according to the ~~previous claim~~ 13, wherein determining the object color comprises computing a weighted average of sub-scan color values derived for corresponding points in overlapping sub-scans at that point of the object surface.

15. (Currently Amended) The focus scanner system according to claim 1 ~~any of the previous claims~~, wherein the data processing system is configured for detecting saturated pixels

in the captured 2D images and for mitigating or removing the error in the derived surface color information or the sub-scan color caused by the pixel saturation.

16. (Currently Amended) The focus scanner system according to the ~~previous claim 15~~, wherein the error caused by the saturated pixel is mitigated or removed by assigning a low weight to the surface color information of the saturated pixel in the computing of the smoothed sub-scan color and/or by assigning a low weight to the sub-scan color computed based on the saturated pixel.

17. (Currently Amended) The focus scanner system according to claim 1 ~~any of the preceding claims~~, wherein the data processing system is configured for comparing the derived surface color information of sections of the captured 2D images and/or of the generated sub-scans of the object with predetermined color ranges for teeth and for oral tissue, and for suppressing the red component of the derived surface color information or sub-scan color for sections where the color is not in one of the two predetermined color ranges.

18. (Currently Amended) The focus scanner system according to claim 1, ~~any of the preceding claims~~ where the color image sensor comprises a color filter array comprising at least three types of colors filters, each allowing light in a known wavelength range, W1, W2, and W3 respectively, to propagate through the color filter.

19. (Currently Amended) The focus scanner system according to claim 1, ~~any of the preceding claims~~ where the surface geometry information is derived from light in a selected wavelength range of the spectrum provided by the multichromatic light source.

20. (Currently Amended) The focus scanner system according to the ~~preceding claim~~ 19, where the color filter array is such that the proportion of the image sensor pixels of the color image sensor with color filters that match the selected wavelength range of the spectrum is larger than 50%, ~~such a wherein the proportion equals 32/36, 60/64 or 96/100.~~

21. (Currently Amended) The focus scanner system according to claim 19 ~~or 20~~, wherein the selected wavelength range matches the W2 wavelength range.

22. (Currently Amended) The focus scanner system according to claim 19 ~~any of claims 19 to 24~~, wherein the color filter array comprises a plurality of cells of 6x6 color filters, where the color filters in positions (2,2) and (5,5) of each cell are of the W1 type, the color filters in positions (2,5) and (5,2) are of the W3 type.

23. (Currently Amended) The focus scanner system according to the ~~preceding claim~~ 22, where the remaining 32 color filters in the 6x6 cell are of the W2 type.

24. (Currently Amended) The focus scanner according to the ~~preceding claim~~ 23, where the pattern generating element is configured to provide that the spatial pattern comprises alternating dark and bright regions arranged in a checkerboard pattern.

25. (Currently Amended) A focus scanner system for recording surface geometry and surface color of an object, the focus scanner system comprising:
a multichromatic light source configured for providing a multichromatic probe light, and
a color image sensor comprising an array of image sensor pixels for capturing one or more 2D images of light received from said object,

where at least for a block of said image sensor pixels, both surface color information and surface geometry information of a part of the object are derived at least partly from one 2D image captured by said color image sensor.

26. (Currently Amended) A method of recording surface geometry and surface color of an object, the method comprising:

obtaining a focus scanner system according to claim 1 ~~any of the previous claims~~;
illuminating the surface of said object with multichromatic probe light from said multichromatic light source;

capturing a series of 2D images of said object using said color image sensor; and
deriving both surface geometry information and surface color information for a block of image sensor pixels at least partly from one captured 2D image.

27. (New) The focus scanner according to claim 1, wherein the same series of 2D images is taken from one pass of the focus scanner along the optical axis.

28. (New) The focus scanner according to claim 1, wherein the multichromatic light source, the color image sensor, and at least a portion of the data processing system are included in a hand held unit.

29. (New) The focus scanner according to claim 19, where the color filter array is such that the proportion of the image sensor pixels of the color image sensor with color filters that match the selected wavelength range of the spectrum has a proportion that equals 32/36, 60/64 or 96/100.

30. (New) The focus scanner according to claim 10, wherein said at least one additional 2D image comprises a neighboring 2D image from the series of captured 2D images.

31. (New) The focus scanner according to claim 12, wherein the averaging of sub-scan colors of different points comprises a weighted averaging of the colors of the surrounding points on the sub-scan.

REMARKS

By way of the foregoing amendment, the claims have been amended to delete multiple dependencies, and to otherwise conform with conventional U.S. format. No new matter has been introduced by these changes. It is to be understood that applicants reserve the right to submit additional claims within the scope of the original claims or supported by the specification.

It is requested that the application be examined on the basis of the amendments presented herein. Early and favorable consideration of this application is respectfully requested.

Should any questions arise in connection with this application, it is respectfully requested that the undersigned be contacted at the number indicated below.

Respectfully submitted,

BUCHANAN INGERSOLL & ROONEY PC

Date: July 28, 2015

By: /Travis D. Boone/
Travis D. Boone
Registration No. 52635

Customer No. 21839
(703) 836-6620

FOCUS SCANNING APPARATUS RECORDING COLOR

Field of the application

- 5 The application relates to three dimensional (3D) scanning of the surface geometry and surface color of objects. A particular application is within dentistry, particularly for intraoral scanning.

Background

10

3D scanners are widely known from the art, and so are intraoral dental 3D scanners (e.g., Sirona Cerec, Cadent Itero, 3Shape TRIOS).

The ability to record surface color is useful in many applications. For example in
15 dentistry, the user can differentiate types of tissue or detect existing restorations. For example in materials inspection, the user can detect surface abnormalities such as crystallization defects or discoloring. None of the above is generally possible from surface geometry information alone.

20 WO2010145669 mentions the possibility of recording color. In particular, several sequential images, each taken for an illumination in a different color - typically blue, green, and red - are combined to form a synthetic color image. This approach hence requires means to change light source color, such as color filters. Furthermore, in handheld use, the scanner will move relative to the scanned object
25 during the illumination sequence, reducing the quality of the synthetic color image.

Also US7698068 and US8102538 (Cadent Inc.) describe an intraoral scanner that records both geometry data and texture data with one or more image sensor(s). However, there is a slight delay between the color and the geometry recording,
30 respectively. US7698068 requires sequential illumination in different colors to form a synthetic image, while US8102538 mentions white light as a possibility, however

from a second illumination source or recorded by a second image sensor, the first set being used for recording the geometry.

WO2012083967 discloses a scanner for recording geometry data and texture data with two separate cameras. While the first camera has a relatively shallow depth of field as to provide focus scanning based on multiple images, the second camera
5 has a relatively large depth of field as to provide color texture information from a single image.

Color-recording scanning confocal microscopes are also known from the prior art
10 (e.g., Keyence VK9700; see also JP2004029373). A white light illumination system along with a color image sensor is used for recording 2D texture, while a laser beam forms a dot that is scanned, i.e., moved over the surface and recorded by a photomultiplier, providing the geometry data from many depth measurements, one for each position of the dot. The principle of a moving dot requires the measured
15 object not to move relative to the microscope during measurement, and hence is not suitable for handheld use.

Summary

20 One aspect of this application is to provide a scanner system and a method for recording surface geometry and surface color of an object, and where surface geometry and surface color are derived from the same captured 2D images.

One aspect of this application is to provide a scanner system for recording surface
25 geometry and surface color of an object, and wherein all 2D images are captured using the same color image sensor.

One aspect of this application is to provide a scanner system and a method for recording surface geometry and surface color of an object, in which the information
30 relating to the surface geometry and to the surface color are acquired simultaneously such that an alignment of data relating to the recorded surface

geometry and data relating to the recorded surface color is not required in order to generate a digital 3D representation of the object expressing both color and geometry of the object.

5 Disclosed is a scanner system for recording surface geometry and surface color of an object, the scanner system comprising:

- a multichromatic light source configured for providing a multichromatic probe light for illumination of the object,
- a color image sensor comprising an array of image sensor pixels for capturing
10 one or more 2D images of light received from said object, and
- a data processing system configured for deriving both surface geometry information and surface color information for a block of said image sensor pixels at least partly from one 2D image recorded by said color image sensor.

15 Disclosed is a method of recording surface geometry and surface color of an object, the method comprising:

- obtaining a scanner system comprising a multichromatic light source and a color image sensor comprising an array of image sensor pixels;
- illuminating the surface of said object with multichromatic probe light from said
20 multichromatic light source;
- capturing a series of 2D images of said object using said color image sensor; and
- deriving both surface geometry information and surface color information for a block of said image sensor pixels at least partly from one captured 2D image.

25

In the context of the present application, the phrase "surface color" may refer to the apparent color of an object surface and thus in some cases, such as for semi-transparent or semi-translucent objects such as teeth, be caused by light from the object surface and/or the material below the object surface, such as material
30 immediately below the object surface.

In the context of the present application, the phrase “derived at least partly from one 2D image” refers to the situation where the surface geometry information for a given block of image sensor pixels at least in part is derived from one 2D image and where the corresponding surface color information at least in part is derived from the same 2D image. The phrase also covers cases where the surface geometry information for a given block of image sensor pixels at least in part is derived from a plurality of 2D images of a series of captured 2D images and where the corresponding surface color information at least in part is derived from the same 2D images of that series of captured 2D images.

10

An advantage of deriving both surface geometry information and surface color information for a block of said image sensor pixels at least partly from one 2D image is that a scanner system having only one image sensor can be realized.

15 It is an advantage that the surface geometry information and the surface color information are derived at least partly from one 2D image, since this inherently provides that the two types of information are acquired simultaneously. There is hence no requirement for an exact timing of the operation of two color image sensors, which may be the case when one image sensor is used for the geometry recording and another for color recording. Equally there is no need for an elaborate calculation accounting for significant differences in the timing of capturing of 2D images from which the surface geometry information is derived and the timing of the capturing of 2D images from which the surface color information is derived.

25 The present application discloses a significant improvement over the state of the art in that only a single image sensor and a single multichromatic light source is required, and that surface color and surface geometry for at least a part of the object can be derived from the same 2D image or 2D images, which also means that alignment of color and surface geometry is inherently perfect. In the scanner system according to the present application, there is no need for taking into account or compensating for relative motion of the object and scanner system between

30

obtaining surface geometry and surface color. Since the surface geometry and the surface color are obtained at precisely the same time, the scanner system automatically maintains its spatial disposition with respect to the object surface while obtaining the surface geometry and the surface color. This makes the scanner system of the present application suitable for handheld use, for example as an
5 intraoral scanner, or for scanning moving objects.

In some embodiments, the data processing system is configured for deriving surface geometry information and surface color information for said block of image sensor pixels from a series of 2D images, such as from a plurality of the 2D images
10 in a series of captured 2D images. I.e. the data processing system is capable of analyzing a plurality of the 2D images in a series of captured 2D images in order to derive the surface geometry information for a block of image sensor pixels and to also derive surface color information from at least one of the 2D images from which
15 the surface geometry information is derived.

In some embodiments, the data processing system is configured for deriving surface color information from a plurality of 2D images of a series of captured 2D images and for deriving surface geometry information from at least one of the 2D
20 images from which the surface color information is derived.

In some embodiments, the data processing system is configured for deriving surface geometry information from a plurality of 2D images of a series of captured 2D images and for deriving surface color information from at least one of the 2D
25 images from which the surface geometry information is derived.

In some embodiments, the set of 2D images from which surface color information is derived from is identical to the set of 2D images from which surface geometry information is derived from.

30

In some embodiments, the data processing system is configured for generating a sub-scan of a part of the object surface based on surface geometry information and surface color information derived from a plurality of blocks of image sensor pixels. The sub-scan expresses at least the geometry of the part of the object and typically one sub-scan is derived from one stack of captured 2D images.

In some embodiments, all 2D images of a captured series of images are analyzed to derive the surface geometry information for each block of image sensor pixels on the color image sensor.

For a given block of image sensor pixels the corresponding portions of the captured 2D images in the stack may be analyzed to derive the surface geometry information and surface color information for that block.

In some embodiments, the surface geometry information relates to where the object surface is located relative to the scanner system coordinate system for that particular block of image sensor pixels.

One advantage of the scanner system and the method of the current application is that the informations used for generating the sub-scan expressing both geometry and color of the object (as seen from one view) are obtained concurrently.

Sub-scans can be generated for a number of different views of the object such that they together cover the part of the surface.

In some embodiments, the data processing system is configured for combining a number of sub-scans to generate a digital 3D representation of the object. The digital 3D representation of the object then preferably expresses both the recorded geometry and color of the object.

The digital 3D representation of the object can be in the form of a data file. When the object is a patient's set of teeth the digital 3D representation of this set of teeth can e.g. be used for CAD/CAM manufacture of a physical model of the patient's set teeth.

5

The surface geometry and the surface color are both determined from light recorded by the color image sensor.

In some embodiments, the light received from the object originates from the multichromatic light source, i.e. it is probe light reflected or scattered from the surface of the object.

10

In some embodiments, the light received from the object comprises fluorescence excited by the probe light from the multichromatic light source, i.e. fluorescence emitted by fluorescent materials in the object surface.

15

In some embodiments, a second light source is used for the excitation of fluorescence while the multichromatic light source provides the light for obtaining the geometry and color of the object.

20

The scanner system preferably comprises an optical system configured for guiding light emitted by the multichromatic light source towards the object to be scanned and for guiding light received from the object to the color image sensor such that the 2D images of said object can be captured by said color image sensor.

25

In some embodiments, the scanner system comprises a first optical system, such as an arrangement of lenses, for transmitting the probe light from the multichromatic light source towards an object and a second optical system for imaging light received from the object at the color image sensor.

30

In some embodiments, single optical system images the probe light onto the object and images the object, or at least a part of the object, onto the color image sensor, preferably along the same optical axis, however in opposite directions along optical axis. The scanner may comprise at least one beam splitter located in the optical path, where the beam splitter is arranged such that it directs the probe light from the multichromatic light source towards the object while it directs light received from the object towards the color image sensor.

Several scanning principles are suitable, such as triangulation and focus scanning.

In some embodiments, the scanner system is a focus scanner system operating by translating a focus plane along an optical axis of the scanner system and capturing the 2D images at different focus plane positions such that each series of captured 2D images forms a stack of 2D images. The focus plane position is preferably shifted along an optical axis of the scanner system, such that 2D images captured at a number of focus plane positions along the optical axis forms said stack of 2D images for a given view of the object, i.e. for a given arrangement of the scanner system relative to the object. After changing the arrangement of the scanner system relative to the object a new stack of 2D images for that view can be captured. The focus plane position may be varied by means of at least one focus element, e.g., a moving focus lens.

In some focus scanner embodiments, the scanner system comprises a pattern generating element configured for incorporating a spatial pattern in said probe light.

In some embodiments, the pattern generating element is configured to provide that the probe light projected by scanner system onto the object comprises a pattern consisting of dark sections and sections with light having the a wavelength distribution according to the wavelength distribution of the multichromatic light source.

In some embodiments, the multichromatic light source comprises a broadband light source, such as a white light source

5 In some embodiments, the pixels of the color image sensor and the pattern generating element are configured to provide that each pixel corresponds to a single bright or dark region of the spatial pattern incorporated in said probe light.

10 For a focus scanner system the surface geometry information for a given block of image sensor pixels is derived by identifying at which distance from the scanner system the object surface is in focus for that block of image sensor pixels.

15 In some embodiments, deriving the surface geometry information and surface color information comprises calculating for several 2D images, such as for several 2D images in a captured stack of 2D images, a correlation measure between the portion of the 2D image captured by said block of image sensor pixels and a weight function. Here the weight function is preferably determined based on information of the configuration of the spatial pattern. The correlation measure may be calculated for each 2D image of the stack.

20 The scanner system may comprise means for evaluating a correlation measure at each focus plane position between at least one image pixel and a weight function, where the weight function is determined based on information of the configuration of the spatial pattern.

25 In some embodiments, deriving the surface geometry information and the surface color information for a block of image sensor pixels comprises identifying the position along the optical axis at which the corresponding correlation measure has a maximum value. The position along the optical axis at which the corresponding correlation measure has a maximum value may coincide with the position where a
30 2D image has been captured but it may even more likely be in between two neighboring 2D images of the stack of 2D images.

Determining the surface geometry information may then relate to calculating a correlation measure of the spatially structured light signal provided by the pattern with the variation of the pattern itself (which we term reference) for every location of the focus plane and finding the location of an extremum of this stack of 2D images. In some embodiments, the pattern is static. Such a static pattern can for example be realized as a chrome-on-glass pattern.

One way to define the correlation measure mathematically with a discrete set of measurements is as a dot product computed from a signal vector, $\mathbf{l} = (l_1, \dots, l_n)$, with $n > 1$ elements representing sensor signals and a reference vector, $\mathbf{f} = (f_1, \dots, f_n)$, of reference weights. The correlation measure A is then given by

$$A = \mathbf{f} \cdot \mathbf{l} = \sum_{i=1}^n f_i l_i$$

The indices on the elements in the signal vector represent sensor signals that are recorded at different pixels, typically in a block of pixels. The reference vector \mathbf{f} can be obtained in a calibration step.

By using knowledge of the optical system used in the scanner, it is possible to transform the location of an extremum of the correlation measure, i.e., the focus plane into depth data information, on a pixel block basis. All pixel blocks combined thus provide an array of depth data. In other words, depth is along an optical path that is known from the optical design and/or found from calibration, and each block of pixels on the image sensor represents the end point of an optical path. Therefore, depth along an optical path, for a bundle of paths, yields a surface geometry within the field of view of the scanner, i.e. a sub-scan for the present view.

It can be advantageous to smooth and interpolate the series of correlation measure values, such as to obtain a more robust and accurate determination of the location of the maximum.

In some embodiments, the generating a sub-scan comprises determining a correlation measure function describing the variation of the correlation measure along the optical axis for each block of image sensor pixels and identifying for the position along the optical axis at which the correlation measure functions have their maximum value for the block.

In some embodiments, the maximum correlation measure value is the highest calculated correlation measure value for the block of image sensor pixels and/or the highest maximum value of the correlation measure function for the block of image sensor pixels.

For example, a polynomial can be fitted to the values of A for a pixel block over several images on both sides of the recorded maximum, and a location of a deducted maximum can be found from the maximum of the fitted polynomial, which can be in between two images. The deducted maximum is subsequently used as depth data information when deriving the surface geometry from the present view, i.e. when deriving a sub-scan for the view.

In some embodiments, the data processing system is configured for determining a color for a point on a generated sub-scan based on the surface color information of the 2D image of the series in which the correlation measure has its maximum value for the corresponding block of image sensor pixels. The color may e.g. be read as the RGB values for pixels in said block of image sensor pixels.

In some embodiments, the data processing system is configured for deriving the color for a point on a generated sub-scan based on the surface color informations of the 2D images in the series in which the correlation measure has its maximum value for the corresponding block of image sensor pixels and on at least one additional 2D image, such as a neighboring 2D image from the series of captured 2D images. The surface color information is still derived from at least one of the 2D images from which the surface geometry information is derived.

In some embodiments, the data processing system is configured for interpolating surface color information of at least two 2D images in a series when determining the sub-scan color, such as an interpolation of surface color information of neighboring
5 2D images in a series.

In some embodiments, the data processing system is configured for computing a smoothed color for a number of points of the sub-scan, where the computing comprises an averaging of sub-scan colors of different points, such as a weighted
10 averaging of the colors of the surrounding points on the sub-scan.

Surface color information for a block of image sensor pixels is at least partially derived from the same image from which surface geometry information is derived. In case the location of the maximum of A is represented by a 2D image, then also
15 color is derived from that same image. In case the location of the maximum of A is found by interpolation to be between two images, then at least one of those two images should be used to derive color, or both images using interpolation for color also. It is also possible to average color data from more than two images used in the determination of the location of the maximum of the correlation measure, or to
20 average color from a subset or superset of multiple images used to derive surface geometry. In any case, some image sensor pixels readings are used to derive both surface color and surface geometry for at least a part of the scanned object.

Typically, there are three color filters, so the overall color is composed of three
25 contributions, such as red, green, and blue, or cyan, magenta, and yellow. Note that color filters typically allow a range of wavelengths to pass, and there is typically cross-talk between filters, such that, for example, some green light will contribute to the intensity measured in pixels with red filters.

30 For an image sensor with a color filter array, a color component c_j within a pixel block can be obtained as

$$c_j = \sum_{i=1}^n g_{j,i} I_i$$

where $g_{j,i} = 1$ if pixel i has a filter for color c_j , 0 otherwise. For an RGB filter array like in a Bayer pattern, j is one of red, green, or blue. Further weighting of the individual color components, i.e., color calibration, may be required to obtain natural color data, typically as compensation for varying filter efficiency, illumination source efficiency, and different fraction of color components in the filter pattern. The calibration may also depend on focus plane location and/or position within the field of view, as the mixing of the light source component colors may vary with those factors.

10 In some embodiments, surface color information is obtained for every pixel in a pixel block. In color image sensors with a color filter array or with other means to separate colors such as diffractive means, depending on the color measured with a particular pixel, an intensity value for that color is obtained. In other words, in this case a particular pixel has a color value only for one color. Recently developed
15 color image sensors allow measurement of several colors in the same pixel, at different depths in the substrate, so in that case, a particular pixel can yield intensity values for several colors. In summary, it is possible to obtain a resolution of the surface color data that is inherently higher than that of the surface geometry information.

20 In the embodiments where the resolution of the derived color is higher than the resolution of the surface geometry for the generated digital 3D representation of the object, a pattern will be visible when at least approximately in focus, which preferably is the case when color is derived. The image can be filtered such as to
25 visually remove the pattern, however at a loss of resolution. In fact, it can be advantageous to be able to see the pattern for the user. For example in intraoral scanning, it may be important to detect the position of a margin line, the rim or edge of a preparation. The image of the pattern overlaid on the geometry of this edge is sharper on a side that is seen approximately perpendicular, and more blurred on the

side that is seen at an acute angle. Thus, a user, who in this example typically is a dentist or dental technician, can use the difference in sharpness to more precisely locate the position of the margin line than may be possible from examining the surface geometry alone.

5

High spatial contrast of an in-focus pattern image on the object is desirable to obtain a good signal to noise ratio of the correlation measure on the color image sensor. Improved spatial contrast can be achieved by preferential imaging of the specular surface reflection from the object on the color image sensor. Thus, some
10 embodiments comprise means for preferential/selective imaging of specularly reflected light. This may be provided if the scanner further comprises means for polarizing the probe light, for example by means of at least one polarizing beam splitter.

15 In some embodiments, the polarizing optics is coated such as to optimize preservation of the circular polarization of a part of the spectrum of the multichromatic light source that is used for recording the surface geometry.

The scanner system may further comprise means for changing the polarization
20 state of the probe light and/or the light received from the object. This can be provided by means of a retardation plate, preferably located in the optical path. In some embodiments, the retardation plate is a quarter wave retardation plate.

Especially for intraoral applications where the scanned object e.g. is the patient's
25 set or teeth, the scanner can have an elongated tip, with means for directing the probe light and/or imaging an object. This may be provided by means of at least one folding element. The folding element could be a light reflecting element such as a mirror or a prism. The probe light then emerges from the scanner system along an optical axis at least partly defined by the folding element.

30

For a more in-depth description of the focus scanning technology, see WO2010145669.

5 In some embodiments, the data processing system is configured for determining the color of a least one point of the generated digital 3D representation of the object, such that the digital 3D representation expresses both geometry and color profile of the object. Color may be determined for several points of the generated digital 3D representation such that the color profile of the scanned part of the object is expressed by the digital 3D representation.

10

In some embodiments determining the object color comprises computing a weighted average of color values derived for corresponding points in overlapping sub-scans at that point of the object surface. This weighted average can then be used as the color of the point in the digital 3D representation of the object.

15

In some embodiments the data processing system is configured for detecting saturated pixels in the captured 2D images and for mitigating or removing the error in the derived surface color information or the sub-scan color caused by the pixel saturation.

20

In some embodiments the error caused by the saturated pixel is mitigated or removed by assigning a low weight to the surface color information of the saturated pixel in the computing of the smoothed color of a sub-scan and/or by assigning a low weight to the color of a sub-scan computed based on the saturated pixel.

25

30 In some embodiments, the data processing system is configured for comparing the derived surface color information of sections of the captured 2D images and/or of the generated sub-scans of the object with predetermined color ranges for teeth and for oral tissue, and for suppressing the red component of the derived surface color information or sub-scan color for sections where the color is not in one of the two predetermined color ranges.

The scanner system disclosed here comprises a multichromatic light source, for example a white light source, for example a multi-die LED.

5 Light received from the scanned object, such as probe light returned from the object surface or fluorescence generated by the probe light by exciting fluorescent parts of the object, is recorded by the color image sensor. In some embodiments, the color image sensor comprises a color filter array such that every pixel in the color image sensor is a color-specific filter. The color filters are preferably arranged in a regular pattern, for example where the color filters are arranged according to a Bayer color
10 filter pattern. The image data thus obtained are used to derive both surface geometry and surface color for each block of pixels. For a focus scanner utilizing a correlation measure, the surface geometry may be found from an extremum of the correlation measure as described above.

15 In some embodiments, the surface geometry is derived from light in a first part of the spectrum of the probe light provided by the multichromatic light source.

Preferably, the color filters are aligned with the image sensor pixels, preferably such that each pixel has a color filter for a particular color only.

20

In some embodiments, the color filter array is such that its proportion of pixels with color filters that match the first part of the spectrum is larger than 50%.

In some embodiments, the surface geometry information is derived from light in a
25 selected wavelength range of the spectrum provided by the multichromatic light source. The light in the other wavelength ranges is hence not used to derive the surface geometry information. This provides the advantage that chromatic dispersion of optical elements in the optical system of the scanner system does not influence the scanning of the object.

30

It can be preferable to compute the surface geometry only from pixels with one or two types of color filters. A single color requires no achromatic optics and is thus provides for a scanner that is easier and cheaper to build. Furthermore, folding elements can generally not preserve the polarization state for all colors equally well.

5 When only some color(s) is/are used to compute surface geometry, the reference vector f will contain zeros for the pixels with filters for the other color(s). Accordingly, the total signal strength is generally reduced, but for large enough blocks of pixels, it is generally still sufficient. Preferentially, the pixel color filters are adapted for little cross-talk from one color to the other(s). Note that even in the embodiments

10 computing geometry from only a subset of pixels, color is preferably still computed from all pixels.

In some embodiments, the color image sensor comprises a color filter array comprising at least three types of colors filters, each allowing light in a known

15 wavelength range, $W1$, $W2$, and $W3$ respectively, to propagate through the color filter.

In some embodiments, the color filter array is such that its proportion of pixels with color filters that match the selected wavelength range of the spectrum is larger than

20 50%, such a wherein the proportion equals 32/36, 60/64 or 96/100.

In some embodiments, the selected wavelength range matches the $W2$ wavelength range.

25 In some embodiments, the color filter array comprises a plurality of cells of 6x6 color filters, where the color filters in positions (2,2) and (5,5) of each cell are of the $W1$ type, the color filters in positions (2,5) and (5,2) are of the $W3$ type. Here a $W1$ type of filter is a color filter that allows light in the known wavelength range $W1$ to propagate through the color filter, and similar for $W2$ and $W3$ type of filters. In some

30 embodiments, the remaining 32 color filters in the 6x6 cell are of the $W2$ type.

In a RGB color system, W1 may correspond to red light, W2 to green light, and W3 to blue light.

5 In some embodiments, the scanner is configured to derive the surface color with a higher resolution than the surface geometry.

In some embodiments, the higher surface color resolution is achieved by demosaicing, where color values for pixel blocks may be demosaiced to achieve an apparently higher resolution of the color image than is present in the surface
10 geometry. The demosaicing may operate on pixel blocks or individual pixels.

In case a multi-die LED or another illumination source comprising physically or optically separated light emitters is used, it is preferable to aim at a Köhler type illumination in the scanner, i.e. the illumination source is defocused at the object
15 plane in order to achieve uniform illumination and good color mixing for the entire field of view. In case color mixing is not perfect and varies with focal plane location, color calibration of the scanner will be advantageous.

In some embodiments, the pattern generating element is configured to provide that
20 the spatial pattern comprises alternating dark and bright regions arranged in a checkerboard pattern. The probe light provided by the scanner system then comprises a pattern consisting of dark sections and sections with light having the same wavelength distribution as the multichromatic light source.

25 In order to obtain a digital 3D representation expressing both surface geometry and color representation of an object, i.e. a colored digital 3D representation of said part of the object surface, typically several sub-scans, i.e. partial representations of the object, have to be combined, where each sub-scans presents one view of the object. A sub-scan expressing a view from a given relative position preferably
30 records the geometry and color of the object surface as seen from that relative position.

For a focus scanner, a view corresponds to one pass of the focusing element(s), i.e. for a focus scanner each sub-scan is the surface geometry and color derived from the stack of 2D images recorded during the pass of the focus plane position
5 between its extremum positions.

The surface geometry found for various views can be combined by algorithms for stitching and registration as widely known in the literature, or from known view positions and orientations, for example when the scanner is mounted on axes with
10 encoders. Color can be interpolated and averaged by methods such as texture weaving, or by simply averaging corresponding color components in multiple views of the same location on the surface. Here, it can be advantageous to account for differences in apparent color due to different angles of incidence and reflection, which is possible because the surface geometry is also known. Texture weaving is
15 described by e.g. Callieri M, Cignoni P, Scopigno R. "Reconstructing textured meshes from multiple range rgb maps". VMV 2002, Erlangen, Nov 20-22, 2002.

In some embodiments, the scanner and/or the scanner system is configured for generating a sub-scan of the object surface based on the obtained surface color
20 and surface geometry.

In some embodiments, the scanner and/or the scanner system is configured for combining sub-scans of the object surface obtained from different relative positions to generate a digital 3D representation expressing the surface geometry and color
25 of at least part of the object.

In some embodiments, the combination of sub-scans of the object to obtain the digital 3D representation expressing surface geometry and color comprises computing the color in each surface point as a weighted average of corresponding
30 points in all overlapping sub-scans at that surface point. The weight of each sub-scan in the sum may be determined by several factors, such as the presence of

saturated pixel values or the orientation of the object surface with respect to the scanner when the sub-scan is recorded.

5 Such a weighted average is advantageous in cases where some scanner positions and orientations relative to the object will give a better estimate of the actual color than other positions and orientations. If the illumination of the object surface is uneven this can to some degree also be compensated for by weighting the best illuminated parts higher.

10 In some embodiments, the data processing system of the scanner system comprises an image processor configured for performing a post-processing of the surface geometry, the surface color readings, or the derived sub-scan or the digital 3D representation of the object. The scanner system may be configured for performing the combination of the sub-scans using e.g. computer implemented
15 algorithms executed by the image processor.

The scanner system may be configured for performing the combination of the sub-scans using e.g. computer implemented algorithms executed by the data processing system as part of the post-processing of the surface geometry, surface
20 color, sub-scan and/or the digital 3D representation, i.e. the post-processing comprises computing the color in each surface point as a weighted average of corresponding points in all overlapping sub-scans at that surface point.

Saturated pixel values should preferably have a low weight to reduce the effect of
25 highlights on the recording of the surface color. The color for a given part of the surface should preferably be determined primarily from 2D images where the color can be determined precisely which is not the case when the pixel values are saturated.

30 In some embodiments, the scanner and/or scanner system is configured for detecting saturated pixels in the captured 2D images and for mitigating or removing

the error in the obtained color caused by the pixel saturation. The error caused by the saturated pixel may be mitigated or removed by assigning a low weight to the saturated pixel in the weighted average.

- 5 Specularly reflected light has the color of the light source rather than the color of the object surface. If the object surface is not a pure white reflector then specular reflections can hence be identified as the areas where the pixel color closely matches the light source color. When obtaining the surface color it is therefore advantageous to assign a low weight to pixels or pixel groups whose color values
10 closely match the color of the multichromatic light source in order to compensate for such specular reflections.

Specular reflections may also be a problem when intra orally scanning a patient's set of teeth since teeth rarely are completely white. It may hence be advantageous
15 to assume that for pixels where the readings from the color images sensor indicate that the surface of the object is a pure white reflector, the light recorded by this pixel group is caused by a specular reflection from the teeth or the soft tissue in the oral cavity and accordingly assign a low weight to these pixels to compensate for the specular reflections.

20

In some embodiments, the compensation for specular reflections from the object surface is based on information derived from a calibration of the scanner in which a calibration object e.g. in the form of a pure white reflector is scanned. The color image sensor readings then depend on the spectrum of the multichromatic light
25 source and on the wavelength dependence of the scanner's optical system caused by e.g. a wavelength dependent reflectance of mirrors in the optical system. If the optical system guides light equally well for all wavelengths of the multichromatic light source, the color image sensor will record the color (also referred to as the spectrum) of the multichromatic light source when the pure white reflector is
30 scanned.

In some embodiments, compensating for the specular reflections from the surface is based on information derived from a calculation based on the wavelength dependence of the scanner's optical system, the spectrum of the multichromatic light source and a wavelength dependent sensitivity of the color image sensor. In

5 some embodiments, the scanner comprises means for optically suppressing specularly reflected light to achieve better color measurement. This may be provided if the scanner further comprises means for polarizing the probe light, for example by means of at least one polarizing beam splitter.

10 When scanning inside an oral cavity there may be red ambient light caused by probe light illumination of surrounding tissue, such as the gingiva, palette, tongue or buccal tissue. In some embodiments, the scanner and/or scanner system is hence configured for suppressing the red component in the recorded 2D images.

15 In some embodiments, the scanner and/or scanner system is configured for comparing the color of sections of the captured 2D images and/or of the sub-scans of the object with predetermined color ranges for teeth and for oral tissue, respectively, and for suppressing the red component of the recorded color for sections where the color is not in either one of the two predetermined color ranges.

20 The teeth may e.g. be assumed to be primarily white with one ratio between the intensity of the different components of the recorded image, e.g. with one ratio between the intensity of the red component and the intensity of the blue and/or green components in a RGB configuration, while oral tissue is primarily reddish with another ratio between the intensity of the components. When a color recorded for a

25 region of the oral cavity shows a ratio which differs from both the predetermined ratio for teeth and the predetermined ratio for tissue, this region is identified as a tooth region illuminated by red ambient light and the red component of the recorded image is suppressed relative to the other components, either by reducing the recorded intensity of the red signal or by increasing the recorded intensities of the

30 other components in the image.

In some embodiments, the color of points with a surface normal directly towards the scanner are weighted higher than the color of points where the surface normal is not directed towards the scanner. This has the advantage that points with a surface normal directly towards the scanner will to a higher degree be illuminated by the white light from the scanner and not by the ambient light.

In some embodiments, the color of points with a surface normal directly towards the scanner are weighted lower if associated with specular reflections.

In some embodiments the scanner is configured for simultaneously compensating for different effects, such as compensating for saturated pixels and/or for specular reflections and/or for orientation of the surface normal. This may be done by generally raising the weight for a selection of pixels or pixel groups of a 2D image and by reducing the weight for a fraction of the pixels or pixel groups of said selection.

In some embodiments, the method comprises a processing of recorded 2D images, a sub-scan or the generated 3D representations of the part of the object, where said processing comprises

- compensating for pixel saturation by omitting or reducing the weight of saturated pixels when deriving the surface color, and/or
- compensating for specular reflections when deriving the surface color by omitting or reducing the weight of pixels whose color values closely matches the light source color, and/or
- compensating for red ambient light by comparing surface color information of the 2D images with predetermined color ranges, and suppressing the red component of the recorded color if this is not within a predetermined color range.

Disclosed is a method of using the disclosed scanner system to display color texture on the generated digital 3D representation of the object. It is advantageous

to display the color data as a texture on the digital 3D representation, for example on a computer screen. The combination of color and geometry is a more powerful conveyor of information than either type of data alone. For example, dentists can more easily differentiate between different types of tissue. In the rendering of the surface geometry, appropriate shading can help convey the surface geometry on the texture, for example with artificial shadows revealing sharp edges better than texture alone could do.

When the multichromatic light source is a multi-die LED or similar, the scanner system can also be used to detect fluorescence. Disclosed is a method of using the disclosed scanner system to display fluorescence on surface geometry.

In some embodiments, the scanner is configured for exciting fluorescence on said object by illuminating it with only a subset of the LED dies in the multi-die LED, and where said fluorescence is recorded by only or preferentially reading out only those pixels in the color image sensor that have color filters at least approximately matching the color of the fluoresced light, i.e. measuring intensity only in pixels of the image sensors that have filters for longer-wavelength light. In other words, the scanner is capable of selectively activating only a subset of the LED dies in the multi-die LED and of only recording or preferentially reading out only those pixels in the color image sensor that have color filters at a higher wavelength than that of the subset of the LED dies, such that light emitted from the subset of LED dies can excite fluorescent materials in the object and the scanner can record the fluorescence emitted from these fluorescent materials. The subset of the dies preferably comprises one or more LED dies which emits light within the excitation spectrum of the fluorescent materials in the object, such as an ultraviolet, a blue, a green, a yellow or a red LED die. Such fluorescence measurement yields a 2D data array much like the 2D color image, however unlike the 2D image it cannot be taken concurrently with the surface geometry. For a slow-moving scanner, and/or with appropriate interpolation, the fluorescence image can still be overlaid the surface

geometry. It is advantageous to display fluorescence on teeth because it can help detect caries and plaque.

5 In some embodiments, the data processing system comprises a microprocessor unit configured for extracting the surface geometry information from 2D images obtained by the color image sensor and for determining the surface color from the same images.

10 The data processing system may comprise units distributed in different parts of the scanner system. For a scanner system comprising a handheld part connected to a stationary unit, the data processing system may for example comprise one unit integrated in the handheld part and another unit integrated in the stationary unit. This can be advantageous when a data connection for transferring data from the handheld unit to the stationary unit has a bandwidth which cannot handle the data
15 stream from the color image sensor. A preliminary data processing in the handheld unit can then reduce the amount of data which must be transferred via the data connection.

20 In some embodiments, the data processing system comprises a computer readable medium on which is stored computer implemented algorithms for performing said post-processing.

In some embodiments, a part of the data processing system is integrated in a cart or a personal computer.

25

Disclosed is a method of using the disclosed scanner system to average color and/or surface geometry from several views, where each view represents a substantially fixed relative orientation of scanner and object.

30 Disclosed is a method using the disclosed scanner system to combine color and/or surface geometry from several views, where each view represents a substantially

fixed relative orientation of scanner and object, such as to achieve a more complete coverage of the object than would be possible in a single view.

Disclosed is a scanner for obtaining surface geometry and surface color of an object, the scanner comprising:

- a multichromatic light source configured for providing a probe light, and
 - a color image sensor comprising an array of image sensor pixels for recording one or more 2D images of light received from said object,
- where at least for a block of said image sensor pixels, both surface color and surface geometry of a part of the object are derived at least partly from one 2D image recorded by said color image sensor

Disclosed is a scanner system for recording surface geometry and surface color of an object, the scanner system comprising:

- a multichromatic light source configured for providing a multichromatic probe light, and
 - a color image sensor comprising an array of image sensor pixels for capturing one or more 2D images of light received from said object,
- where at least for a block of said image sensor pixels, both surface color information and surface geometry information of a part of the object are derived at least partly from one 2D image captured by said color image sensor.

Disclosed is a scanner system for recording surface geometry and surface color of an object, the scanner system comprising:

- a multichromatic light source configured for providing a probe light,
- a color image sensor comprising an array of image sensor pixels, and
- an optical system configured for guiding light received from the object to the color image sensor such that 2D images of said object can be captured by said color image sensor;

wherein the scanner system is configured for capturing a number of said 2D images of a part of the object and for deriving both surface color information and surface

geometry information of the part of the object from at least one of said captured 2D images at least for a block of said color image sensor pixels, such that the surface color information and the surface geometry information are obtained concurrently by the scanner.

5

Disclosed is a scanner system for recording surface geometry and surface color of an object, the scanner system comprising:

- a multichromatic light source configured for providing a probe light;
- a color image sensor comprising an array of image sensor pixels, where
10 the image sensor is arranged to capture 2D images of light received from the object; and
- an image processor configured for deriving both surface color information and surface geometry information of at least a part of the object from at least one of said 2D images captured by the color image sensor.

15

Disclosed is a scanner system for recording surface geometry and surface color of an object, said scanner system comprising

- a scanner system according to any of the embodiments, where the scanner system is configured for deriving surface color and surface
20 geometry of the object, and optionally for generating a sub-scan or a digital 3D representation of the part of the object; and
- a data processing unit configured for post-processing surface geometry and/or surface color readings from the color image sensor, or for post-processing the generated sub-scan or digital 3D representation.

25

Disclosed is a method of recording surface geometry and surface color of an object, the method comprising:

- providing a scanner or scanner system according to any of the embodiments;
- 30 - illuminating the surface of said object with probe light from said multichromatic light source;

- recording one or more 2D images of said object using said color image sensor; and
- deriving both surface color and surface geometry of a part of the object from at least some of said recorded 2D images at least for a block of said image sensor pixels, such that the surface color and surface geometry are obtained concurrently by the scanner.

Brief description of drawings

- 10 Fig. 1 shows a handheld embodiment of a scanner system.
Figs. 2A-2B shows prior art pattern generating means and associated reference weights.
Figs. 3A-3B shows a pattern generating means and associated reference weights.
Fig. 4 shows a color filter array.
- 15 Fig. 5 shows a flow chart of a method.
Figs. 6A-6C illustrates how surface geometry information and surface geometry information can be derived

Fig. 1 shows a handheld part of a scanner system with components inside a housing 100. The scanner comprises a tip which can be entered into a cavity, a multichromatic light source in the form of a multi-die LED 101, pattern generating element 130 for incorporating a spatial pattern in the probe light, a beam splitter 140, color image sensor 180 including an image sensor 181, electronics and potentially other elements, an optical system typically comprising at least one lens, and the image sensor. The light from the light source 101 travels back and forth through the optical system 150. During this passage the optical system images the pattern 130 onto the object being scanned 200 which here is a patient's set of teeth, and further images the object being scanned onto the image sensor 181.

The image sensor 181 has a color filter array 1000. Although drawn as a separate entity, the color filter array is typically integrated with the image sensor, with a single-color filter for every pixel.

5 The lens system includes a focusing element 151 which can be adjusted to shift the focal imaging plane of the pattern on the probed object 200. In the example embodiment, a single lens element is shifted physically back and forth along the optical axis.

10 As a whole, the optical system provides an imaging of the pattern onto the object being probed and from the object being probed to the camera.

The device may include polarization optics 160. Polarization optics can be used to selectively image specular reflections and block out undesired diffuse signal from
15 sub-surface scattering inside the scanned object. The beam splitter 140 may also have polarization filtering properties. It can be advantageous for optical elements to be anti-reflection coated.

The device may include folding optics, a mirror 170, which directs the light out of the
20 device in a direction different to the optical path of the lens system, e.g. in a direction perpendicular to the optical path of the lens system.

There may be additional optical elements in the scanner, for example one or more condenser lens in front of the light source 101.

25

In the example embodiment, the LED 101 is a multi-die LED with two green, one red, and one blue die. Only the green portion of the light is used for obtaining the surface geometry. Accordingly, the mirror 170 is coated such as to optimize preservation of the circular polarization of the green light, and not that of the other
30 colors. Note that during scanning all dies within the LED are active, i.e., emitting light, so the scanner emits apparently white light onto the scanned object 200. The

LED may emit light at the different colors with different intensities such that e.g. one color is more intense than the other colors. This may be desired in order to reduce cross-talk between the readings of the different color signals in the color image sensor. In case that the intensity of e.g. the red and blue diodes in a RGB system is reduced, the apparently white light emitted by the light source will appear greenish-white.

The scanner system further comprises a data processing system configured for deriving both surface geometry information and surface color information for a block of pixels of the color image sensor 180 at least partly from one 2D image recorded by said color image sensor 180. At least part of the data processing system may be arranged in the illustrated handheld part of the scanner system. A part may also be arranged in an additional part of the scanner system, such as a cart connected to the handheld part.

Figures 2A-2B show an section of a prior art pattern generating element 130 that is applied as a static pattern in a spatial correlation embodiment of WO2010145669, as imaged on a monochromatic image sensor 180. The pattern can be a chrome-on-glass pattern. The section shows only a portion of the pattern is shown, namely one period. This period is represented by a pixel block of 6 by 6 image pixels, and 2 by 2 pattern fields. The fields drawn in gray in Fig. 2A are in actuality black because the pattern mask is opaque for these fields; gray was only chosen for visibility and thus clarity of the Figure. Fig. 2B illustrates the reference weights f for computing the spatial correlation measure A for the pixel block, where $n = 6 \times 6 = 36$, such that

$$A = \sum_{i=1}^n f_i I_i$$

where I are the intensity values measured in the 36 pixels in the pixel block for a given image. Note that perfect alignment between image sensor pixels and pattern fields is not required, but gives the best signal for the surface geometry measurement.

Figs. 3A-3B shows the extension of the principle in Figs. 2A-2B to color scanning. The pattern is the same as in Figs. 2A-2B and so is the image sensor geometry. However, the image sensor is a color image sensor with a Bayer color filter array. In Fig. 3A, pixels marked "B" have a blue color filter, while "G" indicates green and "R" red pixel filters, respectively. Fig. 3B shows the corresponding reference weights f . Note that only green pixels have a non-zero value. This is so because only the green fraction of the spectrum is used for recording the surface geometry information.

- 5
10 For the pattern/color filter combination of Figs. 3A-3B, a color component c_j within a pixel block can be obtained as

$$c_j = \sum_{i=1}^n g_{j,i} I_i$$

- where $g_{j,i} = 1$ if pixel i has a filter for color c_j , 0 otherwise. For an RGB color filter array like in the Bayer pattern, j is one of red, green, or blue. Further weighting of the individual color components, i.e., color calibration, may be required to obtain natural color data, typically as compensation for varying filter efficiency, illumination source efficiency, and different fraction of color components in the filter pattern. The calibration may also depend on focus plane location and/or position within the field of view, as the mixing of the LED's component colors may vary with those factors.

- 15
20 Figure 4 shows an inventive color filter array with a higher fraction of green pixels than in the Bayer pattern. The color filter array comprises a plurality of cells of 6x6 color filters, with blue color filters in positions (2,2) and (5,5) of each cell, red color filters in positions (2,5) and (5,2), and green color filters in all remaining positions of the cell.

25

Assuming that only the green portion of the illumination is used to obtain the surface geometry information, the filter of Figure 4 will potentially provide a better quality of the obtained surface geometry than a Bayer pattern filter, at the expense of poorer color representation. The poorer color representation will however in many cases

still be sufficient while the improved quality of the obtained surface geometry often is very advantageous.

5 Fig. 5 illustrates a flow chart 541 of a method of recording surface geometry and surface color of an object.

In step 542 a scanner system according to any of the previous claims is obtained.

10 In step 543 the object is illuminated with multichromatic probe light. In a focus scanning system utilizing a correlation measure or correlation measure function, a checkerboard pattern may be imposed on the probe light such that information relating to the pattern can be used for determining surface geometry information from captured 2D images.

15 In step 544 a series of 2D images of said object is captured using said color image sensor. The 2D images can be processed immediately or stored for later processing in a memory unit.

20 In step 545 both surface geometry information and surface color information are derived for a block of image sensor pixels at least partly from one captured 2D image. The information can e.g. be derived using the correlation measure approach as described herein. The derived informations are combined to generate a sub-scan of the object in step 546, where the sub-scan comprises data expressing the geometry and color of the object as seen from one view.

25

In step 547 a digital 3D representation expressing both color and geometry of the object is generated by combining several sub-scans. This may be done using known algorithms for sub-scan alignment such as algorithms for stitching and registration as widely known in the literature.

30

Figs. 6A-6C illustrates how surface geometry information and surface geometry information can be derived at least from one 2D image for a block of image sensor pixels.

5 The correlation measure is determined for all active image sensor pixel groups on the color image sensor for every focus plane position, i.e. for every 2D image of the stack. Starting by analyzing the 2D images from one end of the stack, the correlation measures for all active image sensor pixel groups is determined and the calculated values are stored. Progressing through the stack the correlation
10 measures for each pixel group are determined and stored together with the previously stored values, i.e. the values for the previously analyzed 2D images. A correlation measure function describing the variation of the correlation measure along the optical axis is then determined for each pixel group by smoothing and interpolating the determined correlation measure values. For example, a polynomial
15 can be fitted to the values of for a pixel block over several images on both sides of the recorded maximum, and a location of a deducted maximum can be found from the maximum of the fitted polynomial, which can be in between two images. The surface color information for the pixel group is derived from one or more of the 2D images from which the position of the correlation measure maximum was
20 determined i.e. surface geometry information and surface color information from a group of pixels of the color image sensor are derived from the same 2D images of the stack.

The surface color information can be derived from one 2D image. The maximum
25 value of the correlation measure for each group of pixels is monitored along the analysis of the 2D images such that when a 2D image has been analyzed the values for the correlation measure for the different pixels groups can be compared with the currently highest value for the previously analyzed 2D images. If the correlation measure is a new maximum value for that pixel group at least the portion
30 of the 2D image corresponding to this pixel group is saved. Next time a higher correlation value is found for that pixel group the portion of this 2D image is saved

overwriting the previously stored image/sub-image. Thereby when all 2D images of the stack have been analyzed, the surface geometry information of the 2D images is translated into a series of correlation measure values for each pixel group where a maximum value is recorded for each block of image sensor pixels.

5

Fig. 6A illustrated a portion 661 of a stack of 2D images acquired using a focus scanning system, where each 2D image is acquired at a different focal plane position. In each 2D image 662 a portion 663 corresponding to a block of image sensor pixels are indicated. The block corresponding to a set of coordinates (x_i, y_i) .
10 The focus scanning system is configured for determining a correlation measure for each block of image sensor pixels and for each 2D image in the stack. In Fig. 6B is illustrated the determined correlation measures 664 (here indicated by an "x") for the block 663. Based on the determined correlation measures 664 a correlation measure function 665 is calculated, here as a polynomial, and a maximum value for
15 the correlation measure function is found a position z_i . The z -value for which the fitted polynomial has a maximum (z_i) is identified as a point of the object surface. The surface geometry information derived for this block can then be presented in the form of the coordinates (x_i, y_i, z_i) , and by combining the surface geometry information for several block of the images sensor, the a sub-scan expressing the
20 geometry of part of the object can be created.

In Fig. 6C is illustrated a procedure for deriving the surface color geometry from two 2D images for each block of image sensor pixels. Two 2D images are stored using the procedure described above and their RGB values for the pixel block are
25 determined. In Fig. 6C the R-values 666 are displayed. An averaged R-value 667 (as well as averaged G- and B-values) at the z_i position can then be determined by interpolation and used as surface color information for this block. This surface color information is evidently derived from the same 2D image that the geometry information at least in part was derived from.

30

FOCUS SCANNING APPARATUS RECORDING COLOR

Field of the application

- 5 The application relates to three dimensional (3D) scanning of the surface geometry and surface color of objects. A particular application is within dentistry, particularly for intraoral scanning.

Background

10

3D scanners are widely known from the art, and so are intraoral dental 3D scanners (e.g., Sirona Cerec, Cadent Itero, 3Shape TRIOS).

The ability to record surface color is useful in many applications. For example in
15 dentistry, the user can differentiate types of tissue or detect existing restorations. For example in materials inspection, the user can detect surface abnormalities such as crystallization defects or discoloring. None of the above is generally possible from surface geometry information alone.

20 WO2010145669 mentions the possibility of recording color. In particular, several sequential images, each taken for an illumination in a different color - typically blue, green, and red - are combined to form a synthetic color image. This approach hence requires means to change light source color, such as color filters. Furthermore, in handheld use, the scanner will move relative to the scanned object
25 during the illumination sequence, reducing the quality of the synthetic color image.

Also US7698068 and US8102538 (Cadent Inc.) describe an intraoral scanner that records both geometry data and texture data with one or more image sensor(s). However, there is a slight delay between the color and the geometry recording,
30 respectively. US7698068 requires sequential illumination in different colors to form a synthetic image, while US8102538 mentions white light as a possibility, however

from a second illumination source or recorded by a second image sensor, the first set being used for recording the geometry.

WO2012083967 discloses a scanner for recording geometry data and texture data with two separate cameras. While the first camera has a relatively shallow depth of field as to provide focus scanning based on multiple images, the second camera
5 has a relatively large depth of field as to provide color texture information from a single image.

Color-recording scanning confocal microscopes are also known from the prior art
10 (e.g., Keyence VK9700; see also JP2004029373). A white light illumination system along with a color image sensor is used for recording 2D texture, while a laser beam forms a dot that is scanned, i.e., moved over the surface and recorded by a photomultiplier, providing the geometry data from many depth measurements, one for each position of the dot. The principle of a moving dot requires the measured
15 object not to move relative to the microscope during measurement, and hence is not suitable for handheld use.

Summary

20 One aspect of this application is to provide a scanner system and a method for recording surface geometry and surface color of an object, and where surface geometry and surface color are derived from the same captured 2D images.

One aspect of this application is to provide a scanner system for recording surface
25 geometry and surface color of an object, and wherein all 2D images are captured using the same color image sensor.

One aspect of this application is to provide a scanner system and a method for recording surface geometry and surface color of an object, in which the information
30 relating to the surface geometry and to the surface color are acquired simultaneously such that an alignment of data relating to the recorded surface

geometry and data relating to the recorded surface color is not required in order to generate a digital 3D representation of the object expressing both color and geometry of the object.

5 Disclosed is a scanner system for recording surface geometry and surface color of an object, the scanner system comprising:

- a multichromatic light source configured for providing a multichromatic probe light for illumination of the object,
- a color image sensor comprising an array of image sensor pixels for capturing
10 one or more 2D images of light received from said object, and
- a data processing system configured for deriving both surface geometry information and surface color information for a block of said image sensor pixels at least partly from one 2D image recorded by said color image sensor.

15 Disclosed is a method of recording surface geometry and surface color of an object, the method comprising:

- obtaining a scanner system comprising a multichromatic light source and a color image sensor comprising an array of image sensor pixels;
- illuminating the surface of said object with multichromatic probe light from said
20 multichromatic light source;
- capturing a series of 2D images of said object using said color image sensor; and
- deriving both surface geometry information and surface color information for a block of said image sensor pixels at least partly from one captured 2D image.

25

In the context of the present application, the phrase "surface color" may refer to the apparent color of an object surface and thus in some cases, such as for semi-transparent or semi-translucent objects such as teeth, be caused by light from the object surface and/or the material below the object surface, such as material
30 immediately below the object surface.

In the context of the present application, the phrase “derived at least partly from one 2D image” refers to the situation where the surface geometry information for a given block of image sensor pixels at least in part is derived from one 2D image and where the corresponding surface color information at least in part is derived from the same 2D image. The phrase also covers cases where the surface geometry information for a given block of image sensor pixels at least in part is derived from a plurality of 2D images of a series of captured 2D images and where the corresponding surface color information at least in part is derived from the same 2D images of that series of captured 2D images.

10

An advantage of deriving both surface geometry information and surface color information for a block of said image sensor pixels at least partly from one 2D image is that a scanner system having only one image sensor can be realized.

15 It is an advantage that the surface geometry information and the surface color information are derived at least partly from one 2D image, since this inherently provides that the two types of information are acquired simultaneously. There is hence no requirement for an exact timing of the operation of two color image sensors, which may be the case when one image sensor is used for the geometry recording and another for color recording. Equally there is no need for an elaborate calculation accounting for significant differences in the timing of capturing of 2D images from which the surface geometry information is derived and the timing of the capturing of 2D images from which the surface color information is derived.

25 The present application discloses a significant improvement over the state of the art in that only a single image sensor and a single multichromatic light source is required, and that surface color and surface geometry for at least a part of the object can be derived from the same 2D image or 2D images, which also means that alignment of color and surface geometry is inherently perfect. In the scanner system according to the present application, there is no need for taking into account or compensating for relative motion of the object and scanner system between

30

obtaining surface geometry and surface color. Since the surface geometry and the surface color are obtained at precisely the same time, the scanner system automatically maintains its spatial disposition with respect to the object surface while obtaining the surface geometry and the surface color. This makes the scanner system of the present application suitable for handheld use, for example as an
5 intraoral scanner, or for scanning moving objects.

In some embodiments, the data processing system is configured for deriving surface geometry information and surface color information for said block of image sensor pixels from a series of 2D images, such as from a plurality of the 2D images
10 in a series of captured 2D images. I.e. the data processing system is capable of analyzing a plurality of the 2D images in a series of captured 2D images in order to derive the surface geometry information for a block of image sensor pixels and to also derive surface color information from at least one of the 2D images from which
15 the surface geometry information is derived.

In some embodiments, the data processing system is configured for deriving surface color information from a plurality of 2D images of a series of captured 2D images and for deriving surface geometry information from at least one of the 2D
20 images from which the surface color information is derived.

In some embodiments, the data processing system is configured for deriving surface geometry information from a plurality of 2D images of a series of captured 2D images and for deriving surface color information from at least one of the 2D
25 images from which the surface geometry information is derived.

In some embodiments, the set of 2D images from which surface color information is derived from is identical to the set of 2D images from which surface geometry information is derived from.

30

In some embodiments, the data processing system is configured for generating a sub-scan of a part of the object surface based on surface geometry information and surface color information derived from a plurality of blocks of image sensor pixels. The sub-scan expresses at least the geometry of the part of the object and typically one sub-scan is derived from one stack of captured 2D images.

In some embodiments, all 2D images of a captured series of images are analyzed to derive the surface geometry information for each block of image sensor pixels on the color image sensor.

For a given block of image sensor pixels the corresponding portions of the captured 2D images in the stack may be analyzed to derive the surface geometry information and surface color information for that block.

In some embodiments, the surface geometry information relates to where the object surface is located relative to the scanner system coordinate system for that particular block of image sensor pixels.

One advantage of the scanner system and the method of the current application is that the informations used for generating the sub-scan expressing both geometry and color of the object (as seen from one view) are obtained concurrently.

Sub-scans can be generated for a number of different views of the object such that they together cover the part of the surface.

In some embodiments, the data processing system is configured for combining a number of sub-scans to generate a digital 3D representation of the object. The digital 3D representation of the object then preferably expresses both the recorded geometry and color of the object.

The digital 3D representation of the object can be in the form of a data file. When the object is a patient's set of teeth the digital 3D representation of this set of teeth can e.g. be used for CAD/CAM manufacture of a physical model of the patient's set teeth.

5

The surface geometry and the surface color are both determined from light recorded by the color image sensor.

In some embodiments, the light received from the object originates from the multichromatic light source, i.e. it is probe light reflected or scattered from the surface of the object.

10

In some embodiments, the light received from the object comprises fluorescence excited by the probe light from the multichromatic light source, i.e. fluorescence emitted by fluorescent materials in the object surface.

15

In some embodiments, a second light source is used for the excitation of fluorescence while the multichromatic light source provides the light for obtaining the geometry and color of the object.

20

The scanner system preferably comprises an optical system configured for guiding light emitted by the multichromatic light source towards the object to be scanned and for guiding light received from the object to the color image sensor such that the 2D images of said object can be captured by said color image sensor.

25

In some embodiments, the scanner system comprises a first optical system, such as an arrangement of lenses, for transmitting the probe light from the multichromatic light source towards an object and a second optical system for imaging light received from the object at the color image sensor.

30

In some embodiments, single optical system images the probe light onto the object and images the object, or at least a part of the object, onto the color image sensor, preferably along the same optical axis, however in opposite directions along optical axis. The scanner may comprise at least one beam splitter located in the optical path, where the beam splitter is arranged such that it directs the probe light from the multichromatic light source towards the object while it directs light received from the object towards the color image sensor.

Several scanning principles are suitable, such as triangulation and focus scanning.

In some embodiments, the scanner system is a focus scanner system operating by translating a focus plane along an optical axis of the scanner system and capturing the 2D images at different focus plane positions such that each series of captured 2D images forms a stack of 2D images. The focus plane position is preferably shifted along an optical axis of the scanner system, such that 2D images captured at a number of focus plane positions along the optical axis forms said stack of 2D images for a given view of the object, i.e. for a given arrangement of the scanner system relative to the object. After changing the arrangement of the scanner system relative to the object a new stack of 2D images for that view can be captured. The focus plane position may be varied by means of at least one focus element, e.g., a moving focus lens.

In some focus scanner embodiments, the scanner system comprises a pattern generating element configured for incorporating a spatial pattern in said probe light.

In some embodiments, the pattern generating element is configured to provide that the probe light projected by scanner system onto the object comprises a pattern consisting of dark sections and sections with light having the a wavelength distribution according to the wavelength distribution of the multichromatic light source.

In some embodiments, the multichromatic light source comprises a broadband light source, such as a white light source

5 In some embodiments, the pixels of the color image sensor and the pattern generating element are configured to provide that each pixel corresponds to a single bright or dark region of the spatial pattern incorporated in said probe light.

10 For a focus scanner system the surface geometry information for a given block of image sensor pixels is derived by identifying at which distance from the scanner system the object surface is in focus for that block of image sensor pixels.

15 In some embodiments, deriving the surface geometry information and surface color information comprises calculating for several 2D images, such as for several 2D images in a captured stack of 2D images, a correlation measure between the portion of the 2D image captured by said block of image sensor pixels and a weight function. Here the weight function is preferably determined based on information of the configuration of the spatial pattern. The correlation measure may be calculated for each 2D image of the stack.

20 The scanner system may comprise means for evaluating a correlation measure at each focus plane position between at least one image pixel and a weight function, where the weight function is determined based on information of the configuration of the spatial pattern.

25 In some embodiments, deriving the surface geometry information and the surface color information for a block of image sensor pixels comprises identifying the position along the optical axis at which the corresponding correlation measure has a maximum value. The position along the optical axis at which the corresponding correlation measure has a maximum value may coincide with the position where a
30 2D image has been captured but it may even more likely be in between two neighboring 2D images of the stack of 2D images.

Determining the surface geometry information may then relate to calculating a correlation measure of the spatially structured light signal provided by the pattern with the variation of the pattern itself (which we term reference) for every location of the focus plane and finding the location of an extremum of this stack of 2D images. In some embodiments, the pattern is static. Such a static pattern can for example be realized as a chrome-on-glass pattern.

One way to define the correlation measure mathematically with a discrete set of measurements is as a dot product computed from a signal vector, $\mathbf{l} = (l_1, \dots, l_n)$, with $n > 1$ elements representing sensor signals and a reference vector, $\mathbf{f} = (f_1, \dots, f_n)$, of reference weights. The correlation measure A is then given by

$$A = \mathbf{f} \cdot \mathbf{l} = \sum_{i=1}^n f_i l_i$$

The indices on the elements in the signal vector represent sensor signals that are recorded at different pixels, typically in a block of pixels. The reference vector \mathbf{f} can be obtained in a calibration step.

By using knowledge of the optical system used in the scanner, it is possible to transform the location of an extremum of the correlation measure, i.e., the focus plane into depth data information, on a pixel block basis. All pixel blocks combined thus provide an array of depth data. In other words, depth is along an optical path that is known from the optical design and/or found from calibration, and each block of pixels on the image sensor represents the end point of an optical path. Therefore, depth along an optical path, for a bundle of paths, yields a surface geometry within the field of view of the scanner, i.e. a sub-scan for the present view.

It can be advantageous to smooth and interpolate the series of correlation measure values, such as to obtain a more robust and accurate determination of the location of the maximum.

In some embodiments, the generating a sub-scan comprises determining a correlation measure function describing the variation of the correlation measure along the optical axis for each block of image sensor pixels and identifying for the position along the optical axis at which the correlation measure functions have their maximum value for the block.

In some embodiments, the maximum correlation measure value is the highest calculated correlation measure value for the block of image sensor pixels and/or the highest maximum value of the correlation measure function for the block of image sensor pixels.

For example, a polynomial can be fitted to the values of A for a pixel block over several images on both sides of the recorded maximum, and a location of a deduced maximum can be found from the maximum of the fitted polynomial, which can be in between two images. The deduced maximum is subsequently used as depth data information when deriving the surface geometry from the present view, i.e. when deriving a sub-scan for the view.

In some embodiments, the data processing system is configured for determining a color for a point on a generated sub-scan based on the surface color information of the 2D image of the series in which the correlation measure has its maximum value for the corresponding block of image sensor pixels. The color may e.g. be read as the RGB values for pixels in said block of image sensor pixels.

In some embodiments, the data processing system is configured for deriving the color for a point on a generated sub-scan based on the surface color informations of the 2D images in the series in which the correlation measure has its maximum value for the corresponding block of image sensor pixels and on at least one additional 2D image, such as a neighboring 2D image from the series of captured 2D images. The surface color information is still derived from at least one of the 2D images from which the surface geometry information is derived.

In some embodiments, the data processing system is configured for interpolating surface color information of at least two 2D images in a series when determining the sub-scan color, such as an interpolation of surface color information of neighboring
5 2D images in a series.

In some embodiments, the data processing system is configured for computing a smoothed color for a number of points of the sub-scan, where the computing comprises an averaging of sub-scan colors of different points, such as a weighted
10 averaging of the colors of the surrounding points on the sub-scan.

Surface color information for a block of image sensor pixels is at least partially derived from the same image from which surface geometry information is derived. In case the location of the maximum of A is represented by a 2D image, then also
15 color is derived from that same image. In case the location of the maximum of A is found by interpolation to be between two images, then at least one of those two images should be used to derive color, or both images using interpolation for color also. It is also possible to average color data from more than two images used in the determination of the location of the maximum of the correlation measure, or to
20 average color from a subset or superset of multiple images used to derive surface geometry. In any case, some image sensor pixels readings are used to derive both surface color and surface geometry for at least a part of the scanned object.

Typically, there are three color filters, so the overall color is composed of three
25 contributions, such as red, green, and blue, or cyan, magenta, and yellow. Note that color filters typically allow a range of wavelengths to pass, and there is typically cross-talk between filters, such that, for example, some green light will contribute to the intensity measured in pixels with red filters.

30 For an image sensor with a color filter array, a color component c_j within a pixel block can be obtained as

$$c_j = \sum_{i=1}^n g_{j,i} I_i$$

where $g_{j,i} = 1$ if pixel i has a filter for color c_j , 0 otherwise. For an RGB filter array like in a Bayer pattern, j is one of red, green, or blue. Further weighting of the individual color components, i.e., color calibration, may be required to obtain natural color data, typically as compensation for varying filter efficiency, illumination source efficiency, and different fraction of color components in the filter pattern. The calibration may also depend on focus plane location and/or position within the field of view, as the mixing of the light source component colors may vary with those factors.

10 In some embodiments, surface color information is obtained for every pixel in a pixel block. In color image sensors with a color filter array or with other means to separate colors such as diffractive means, depending on the color measured with a particular pixel, an intensity value for that color is obtained. In other words, in this case a particular pixel has a color value only for one color. Recently developed
15 color image sensors allow measurement of several colors in the same pixel, at different depths in the substrate, so in that case, a particular pixel can yield intensity values for several colors. In summary, it is possible to obtain a resolution of the surface color data that is inherently higher than that of the surface geometry information.

20 In the embodiments where the resolution of the derived color is higher than the resolution of the surface geometry for the generated digital 3D representation of the object, a pattern will be visible when at least approximately in focus, which preferably is the case when color is derived. The image can be filtered such as to
25 visually remove the pattern, however at a loss of resolution. In fact, it can be advantageous to be able to see the pattern for the user. For example in intraoral scanning, it may be important to detect the position of a margin line, the rim or edge of a preparation. The image of the pattern overlaid on the geometry of this edge is sharper on a side that is seen approximately perpendicular, and more blurred on the

side that is seen at an acute angle. Thus, a user, who in this example typically is a dentist or dental technician, can use the difference in sharpness to more precisely locate the position of the margin line than may be possible from examining the surface geometry alone.

5

High spatial contrast of an in-focus pattern image on the object is desirable to obtain a good signal to noise ratio of the correlation measure on the color image sensor. Improved spatial contrast can be achieved by preferential imaging of the specular surface reflection from the object on the color image sensor. Thus, some
10 embodiments comprise means for preferential/selective imaging of specularly reflected light. This may be provided if the scanner further comprises means for polarizing the probe light, for example by means of at least one polarizing beam splitter.

15 In some embodiments, the polarizing optics is coated such as to optimize preservation of the circular polarization of a part of the spectrum of the multichromatic light source that is used for recording the surface geometry.

The scanner system may further comprise means for changing the polarization
20 state of the probe light and/or the light received from the object. This can be provided by means of a retardation plate, preferably located in the optical path. In some embodiments, the retardation plate is a quarter wave retardation plate.

Especially for intraoral applications where the scanned object e.g. is the patient's
25 set or teeth, the scanner can have an elongated tip, with means for directing the probe light and/or imaging an object. This may be provided by means of at least one folding element. The folding element could be a light reflecting element such as a mirror or a prism. The probe light then emerges from the scanner system along an optical axis at least partly defined by the folding element.

30

For a more in-depth description of the focus scanning technology, see WO2010145669.

5 In some embodiments, the data processing system is configured for determining the color of a least one point of the generated digital 3D representation of the object, such that the digital 3D representation expresses both geometry and color profile of the object. Color may be determined for several points of the generated digital 3D representation such that the color profile of the scanned part of the object is expressed by the digital 3D representation.

10

In some embodiments determining the object color comprises computing a weighted average of color values derived for corresponding points in overlapping sub-scans at that point of the object surface. This weighted average can then be used as the color of the point in the digital 3D representation of the object.

15

In some embodiments the data processing system is configured for detecting saturated pixels in the captured 2D images and for mitigating or removing the error in the derived surface color information or the sub-scan color caused by the pixel saturation.

20

In some embodiments the error caused by the saturated pixel is mitigated or removed by assigning a low weight to the surface color information of the saturated pixel in the computing of the smoothed color of a sub-scan and/or by assigning a low weight to the color of a sub-scan computed based on the saturated pixel.

25

30 In some embodiments, the data processing system is configured for comparing the derived surface color information of sections of the captured 2D images and/or of the generated sub-scans of the object with predetermined color ranges for teeth and for oral tissue, and for suppressing the red component of the derived surface color information or sub-scan color for sections where the color is not in one of the two predetermined color ranges.

The scanner system disclosed here comprises a multichromatic light source, for example a white light source, for example a multi-die LED.

5 Light received from the scanned object, such as probe light returned from the object surface or fluorescence generated by the probe light by exciting fluorescent parts of the object, is recorded by the color image sensor. In some embodiments, the color image sensor comprises a color filter array such that every pixel in the color image sensor is a color-specific filter. The color filters are preferably arranged in a regular pattern, for example where the color filters are arranged according to a Bayer color
10 filter pattern. The image data thus obtained are used to derive both surface geometry and surface color for each block of pixels. For a focus scanner utilizing a correlation measure, the surface geometry may be found from an extremum of the correlation measure as described above.

15 In some embodiments, the surface geometry is derived from light in a first part of the spectrum of the probe light provided by the multichromatic light source.

Preferably, the color filters are aligned with the image sensor pixels, preferably such that each pixel has a color filter for a particular color only.

20

In some embodiments, the color filter array is such that its proportion of pixels with color filters that match the first part of the spectrum is larger than 50%.

In some embodiments, the surface geometry information is derived from light in a
25 selected wavelength range of the spectrum provided by the multichromatic light source. The light in the other wavelength ranges is hence not used to derive the surface geometry information. This provides the advantage that chromatic dispersion of optical elements in the optical system of the scanner system does not influence the scanning of the object.

30

It can be preferable to compute the surface geometry only from pixels with one or two types of color filters. A single color requires no achromatic optics and is thus provides for a scanner that is easier and cheaper to build. Furthermore, folding elements can generally not preserve the polarization state for all colors equally well.

5 When only some color(s) is/are used to compute surface geometry, the reference vector f will contain zeros for the pixels with filters for the other color(s). Accordingly, the total signal strength is generally reduced, but for large enough blocks of pixels, it is generally still sufficient. Preferentially, the pixel color filters are adapted for little cross-talk from one color to the other(s). Note that even in the embodiments

10 computing geometry from only a subset of pixels, color is preferably still computed from all pixels.

In some embodiments, the color image sensor comprises a color filter array comprising at least three types of colors filters, each allowing light in a known

15 wavelength range, $W1$, $W2$, and $W3$ respectively, to propagate through the color filter.

In some embodiments, the color filter array is such that its proportion of pixels with color filters that match the selected wavelength range of the spectrum is larger than

20 50%, such a wherein the proportion equals 32/36, 60/64 or 96/100.

In some embodiments, the selected wavelength range matches the $W2$ wavelength range.

25 In some embodiments, the color filter array comprises a plurality of cells of 6x6 color filters, where the color filters in positions (2,2) and (5,5) of each cell are of the $W1$ type, the color filters in positions (2,5) and (5,2) are of the $W3$ type. Here a $W1$ type of filter is a color filter that allows light in the known wavelength range $W1$ to propagate through the color filter, and similar for $W2$ and $W3$ type of filters. In some

30 embodiments, the remaining 32 color filters in the 6x6 cell are of the $W2$ type.

In a RGB color system, W1 may correspond to red light, W2 to green light, and W3 to blue light.

5 In some embodiments, the scanner is configured to derive the surface color with a higher resolution than the surface geometry.

In some embodiments, the higher surface color resolution is achieved by demosaicing, where color values for pixel blocks may be demosaiced to achieve an apparently higher resolution of the color image than is present in the surface geometry. The demosaicing may operate on pixel blocks or individual pixels.

10 In case a multi-die LED or another illumination source comprising physically or optically separated light emitters is used, it is preferable to aim at a Köhler type illumination in the scanner, i.e. the illumination source is defocused at the object plane in order to achieve uniform illumination and good color mixing for the entire field of view. In case color mixing is not perfect and varies with focal plane location, color calibration of the scanner will be advantageous.

20 In some embodiments, the pattern generating element is configured to provide that the spatial pattern comprises alternating dark and bright regions arranged in a checkerboard pattern. The probe light provided by the scanner system then comprises a pattern consisting of dark sections and sections with light having the same wavelength distribution as the multichromatic light source.

25 In order to obtain a digital 3D representation expressing both surface geometry and color representation of an object, i.e. a colored digital 3D representation of said part of the object surface, typically several sub-scans, i.e. partial representations of the object, have to be combined, where each sub-scans presents one view of the object. A sub-scan expressing a view from a given relative position preferably records the geometry and color of the object surface as seen from that relative position.

For a focus scanner, a view corresponds to one pass of the focusing element(s), i.e. for a focus scanner each sub-scan is the surface geometry and color derived from the stack of 2D images recorded during the pass of the focus plane position
5 between its extremum positions.

The surface geometry found for various views can be combined by algorithms for stitching and registration as widely known in the literature, or from known view positions and orientations, for example when the scanner is mounted on axes with
10 encoders. Color can be interpolated and averaged by methods such as texture weaving, or by simply averaging corresponding color components in multiple views of the same location on the surface. Here, it can be advantageous to account for differences in apparent color due to different angles of incidence and reflection, which is possible because the surface geometry is also known. Texture weaving is
15 described by e.g. Callieri M, Cignoni P, Scopigno R. "Reconstructing textured meshes from multiple range rgb maps". VMV 2002, Erlangen, Nov 20-22, 2002.

In some embodiments, the scanner and/or the scanner system is configured for generating a sub-scan of the object surface based on the obtained surface color
20 and surface geometry.

In some embodiments, the scanner and/or the scanner system is configured for combining sub-scans of the object surface obtained from different relative positions to generate a digital 3D representation expressing the surface geometry and color
25 of at least part of the object.

In some embodiments, the combination of sub-scans of the object to obtain the digital 3D representation expressing surface geometry and color comprises computing the color in each surface point as a weighted average of corresponding
30 points in all overlapping sub-scans at that surface point. The weight of each sub-scan in the sum may be determined by several factors, such as the presence of

saturated pixel values or the orientation of the object surface with respect to the scanner when the sub-scan is recorded.

5 Such a weighted average is advantageous in cases where some scanner positions and orientations relative to the object will give a better estimate of the actual color than other positions and orientations. If the illumination of the object surface is uneven this can to some degree also be compensated for by weighting the best illuminated parts higher.

10 In some embodiments, the data processing system of the scanner system comprises an image processor configured for performing a post-processing of the surface geometry, the surface color readings, or the derived sub-scan or the digital 3D representation of the object. The scanner system may be configured for performing the combination of the sub-scans using e.g. computer implemented
15 algorithms executed by the image processor.

The scanner system may be configured for performing the combination of the sub-scans using e.g. computer implemented algorithms executed by the data processing system as part of the post-processing of the surface geometry, surface
20 color, sub-scan and/or the digital 3D representation, i.e. the post-processing comprises computing the color in each surface point as a weighted average of corresponding points in all overlapping sub-scans at that surface point.

Saturated pixel values should preferably have a low weight to reduce the effect of
25 highlights on the recording of the surface color. The color for a given part of the surface should preferably be determined primarily from 2D images where the color can be determined precisely which is not the case when the pixel values are saturated.

30 In some embodiments, the scanner and/or scanner system is configured for detecting saturated pixels in the captured 2D images and for mitigating or removing

the error in the obtained color caused by the pixel saturation. The error caused by the saturated pixel may be mitigated or removed by assigning a low weight to the saturated pixel in the weighted average.

- 5 Specularly reflected light has the color of the light source rather than the color of the object surface. If the object surface is not a pure white reflector then specular reflections can hence be identified as the areas where the pixel color closely matches the light source color. When obtaining the surface color it is therefore advantageous to assign a low weight to pixels or pixel groups whose color values
- 10 closely match the color of the multichromatic light source in order to compensate for such specular reflections.

Specular reflections may also be a problem when intra orally scanning a patient's set of teeth since teeth rarely are completely white. It may hence be advantageous

15 to assume that for pixels where the readings from the color images sensor indicate that the surface of the object is a pure white reflector, the light recorded by this pixel group is caused by a specular reflection from the teeth or the soft tissue in the oral cavity and accordingly assign a low weight to these pixels to compensate for the specular reflections.

20

In some embodiments, the compensation for specular reflections from the object surface is based on information derived from a calibration of the scanner in which a calibration object e.g. in the form of a pure white reflector is scanned. The color image sensor readings then depend on the spectrum of the multichromatic light

25 source and on the wavelength dependence of the scanner's optical system caused by e.g. a wavelength dependent reflectance of mirrors in the optical system. If the optical system guides light equally well for all wavelengths of the multichromatic light source, the color image sensor will record the color (also referred to as the spectrum) of the multichromatic light source when the pure white reflector is

30 scanned.

- In some embodiments, compensating for the specular reflections from the surface is based on information derived from a calculation based on the wavelength dependence of the scanner's optical system, the spectrum of the multichromatic light source and a wavelength dependent sensitivity of the color image sensor.
- 5 In some embodiments, the scanner comprises means for optically suppressing specularly reflected light to achieve better color measurement. This may be provided if the scanner further comprises means for polarizing the probe light, for example by means of at least one polarizing beam splitter.
- 10 When scanning inside an oral cavity there may be red ambient light caused by probe light illumination of surrounding tissue, such as the gingiva, palette, tongue or buccal tissue. In some embodiments, the scanner and/or scanner system is hence configured for suppressing the red component in the recorded 2D images.
- 15 In some embodiments, the scanner and/or scanner system is configured for comparing the color of sections of the captured 2D images and/or of the sub-scans of the object with predetermined color ranges for teeth and for oral tissue, respectively, and for suppressing the red component of the recorded color for sections where the color is not in either one of the two predetermined color ranges.
- 20 The teeth may e.g. be assumed to be primarily white with one ratio between the intensity of the different components of the recorded image, e.g. with one ratio between the intensity of the red component and the intensity of the blue and/or green components in a RGB configuration, while oral tissue is primarily reddish with another ratio between the intensity of the components. When a color recorded for a
- 25 region of the oral cavity shows a ratio which differs from both the predetermined ratio for teeth and the predetermined ratio for tissue, this region is identified as a tooth region illuminated by red ambient light and the red component of the recorded image is suppressed relative to the other components, either by reducing the recorded intensity of the red signal or by increasing the recorded intensities of the
- 30 other components in the image.

In some embodiments, the color of points with a surface normal directly towards the scanner are weighted higher than the color of points where the surface normal is not directed towards the scanner. This has the advantage that points with a surface normal directly towards the scanner will to a higher degree be illuminated by the white light from the scanner and not by the ambient light.

In some embodiments, the color of points with a surface normal directly towards the scanner are weighted lower if associated with specular reflections.

In some embodiments the scanner is configured for simultaneously compensating for different effects, such as compensating for saturated pixels and/or for specular reflections and/or for orientation of the surface normal. This may be done by generally raising the weight for a selection of pixels or pixel groups of a 2D image and by reducing the weight for a fraction of the pixels or pixel groups of said selection.

In some embodiments, the method comprises a processing of recorded 2D images, a sub-scan or the generated 3D representations of the part of the object, where said processing comprises

- compensating for pixel saturation by omitting or reducing the weight of saturated pixels when deriving the surface color, and/or
- compensating for specular reflections when deriving the surface color by omitting or reducing the weight of pixels whose color values closely matches the light source color, and/or
- compensating for red ambient light by comparing surface color information of the 2D images with predetermined color ranges, and suppressing the red component of the recorded color if this is not within a predetermined color range.

Disclosed is a method of using the disclosed scanner system to display color texture on the generated digital 3D representation of the object. It is advantageous

to display the color data as a texture on the digital 3D representation, for example on a computer screen. The combination of color and geometry is a more powerful conveyor of information than either type of data alone. For example, dentists can more easily differentiate between different types of tissue. In the rendering of the surface geometry, appropriate shading can help convey the surface geometry on the texture, for example with artificial shadows revealing sharp edges better than texture alone could do.

When the multichromatic light source is a multi-die LED or similar, the scanner system can also be used to detect fluorescence. Disclosed is a method of using the disclosed scanner system to display fluorescence on surface geometry.

In some embodiments, the scanner is configured for exciting fluorescence on said object by illuminating it with only a subset of the LED dies in the multi-die LED, and where said fluorescence is recorded by only or preferentially reading out only those pixels in the color image sensor that have color filters at least approximately matching the color of the fluoresced light, i.e. measuring intensity only in pixels of the image sensors that have filters for longer-wavelength light. In other words, the scanner is capable of selectively activating only a subset of the LED dies in the multi-die LED and of only recording or preferentially reading out only those pixels in the color image sensor that have color filters at a higher wavelength than that of the subset of the LED dies, such that light emitted from the subset of LED dies can excite fluorescent materials in the object and the scanner can record the fluorescence emitted from these fluorescent materials. The subset of the dies preferably comprises one or more LED dies which emits light within the excitation spectrum of the fluorescent materials in the object, such as an ultraviolet, a blue, a green, a yellow or a red LED die. Such fluorescence measurement yields a 2D data array much like the 2D color image, however unlike the 2D image it cannot be taken concurrently with the surface geometry. For a slow-moving scanner, and/or with appropriate interpolation, the fluorescence image can still be overlaid the surface

geometry. It is advantageous to display fluorescence on teeth because it can help detect caries and plaque.

5 In some embodiments, the data processing system comprises a microprocessor unit configured for extracting the surface geometry information from 2D images obtained by the color image sensor and for determining the surface color from the same images.

10 The data processing system may comprise units distributed in different parts of the scanner system. For a scanner system comprising a handheld part connected to a stationary unit, the data processing system may for example comprise one unit integrated in the handheld part and another unit integrated in the stationary unit. This can be advantageous when a data connection for transferring data from the handheld unit to the stationary unit has a bandwidth which cannot handle the data stream from the color image sensor. A preliminary data processing in the handheld unit can then reduce the amount of data which must be transferred via the data connection.

20 In some embodiments, the data processing system comprises a computer readable medium on which is stored computer implemented algorithms for performing said post-processing.

In some embodiments, a part of the data processing system is integrated in a cart or a personal computer.

25

Disclosed is a method of using the disclosed scanner system to average color and/or surface geometry from several views, where each view represents a substantially fixed relative orientation of scanner and object.

30 Disclosed is a method using the disclosed scanner system to combine color and/or surface geometry from several views, where each view represents a substantially

fixed relative orientation of scanner and object, such as to achieve a more complete coverage of the object than would be possible in a single view.

Disclosed is a scanner for obtaining surface geometry and surface color of an object, the scanner comprising:

- a multichromatic light source configured for providing a probe light, and
 - a color image sensor comprising an array of image sensor pixels for recording one or more 2D images of light received from said object,
- where at least for a block of said image sensor pixels, both surface color and surface geometry of a part of the object are derived at least partly from one 2D image recorded by said color image sensor

Disclosed is a scanner system for recording surface geometry and surface color of an object, the scanner system comprising:

- a multichromatic light source configured for providing a multichromatic probe light, and
 - a color image sensor comprising an array of image sensor pixels for capturing one or more 2D images of light received from said object,
- where at least for a block of said image sensor pixels, both surface color information and surface geometry information of a part of the object are derived at least partly from one 2D image captured by said color image sensor.

Disclosed is a scanner system for recording surface geometry and surface color of an object, the scanner system comprising:

- a multichromatic light source configured for providing a probe light,
- a color image sensor comprising an array of image sensor pixels, and
- an optical system configured for guiding light received from the object to the color image sensor such that 2D images of said object can be captured by said color image sensor;

wherein the scanner system is configured for capturing a number of said 2D images of a part of the object and for deriving both surface color information and surface

geometry information of the part of the object from at least one of said captured 2D images at least for a block of said color image sensor pixels, such that the surface color information and the surface geometry information are obtained concurrently by the scanner.

5

Disclosed is a scanner system for recording surface geometry and surface color of an object, the scanner system comprising:

- a multichromatic light source configured for providing a probe light;
- a color image sensor comprising an array of image sensor pixels, where
10 the image sensor is arranged to capture 2D images of light received from the object; and
- an image processor configured for deriving both surface color information and surface geometry information of at least a part of the object from at least one of said 2D images captured by the color image sensor.

15

Disclosed is a scanner system for recording surface geometry and surface color of an object, said scanner system comprising

- a scanner system according to any of the embodiments, where the scanner system is configured for deriving surface color and surface
20 geometry of the object, and optionally for generating a sub-scan or a digital 3D representation of the part of the object; and
- a data processing unit configured for post-processing surface geometry and/or surface color readings from the color image sensor, or for post-processing the generated sub-scan or digital 3D representation.

25

Disclosed is a method of recording surface geometry and surface color of an object, the method comprising:

- providing a scanner or scanner system according to any of the embodiments;
- 30 - illuminating the surface of said object with probe light from said multichromatic light source;

- recording one or more 2D images of said object using said color image sensor; and
- deriving both surface color and surface geometry of a part of the object from at least some of said recorded 2D images at least for a block of said image sensor pixels, such that the surface color and surface geometry are obtained concurrently by the scanner.

Brief description of drawings

- 10 Fig. 1 shows a handheld embodiment of a scanner system.
Figs. 2A-2B shows prior art pattern generating means and associated reference weights.
Figs. 3A-3B shows a pattern generating means and associated reference weights.
Fig. 4 shows a color filter array.
- 15 Fig. 5 shows a flow chart of a method.
Figs. 6A-6C illustrates how surface geometry information and surface geometry information can be derived

Fig. 1 shows a handheld part of a scanner system with components inside a housing 100. The scanner comprises a tip which can be entered into a cavity, a multichromatic light source in the form of a multi-die LED 101, pattern generating element 130 for incorporating a spatial pattern in the probe light, a beam splitter 140, color image sensor 180 including an image sensor 181, electronics and potentially other elements, an optical system typically comprising at least one lens, and the image sensor. The light from the light source 101 travels back and forth through the optical system 150. During this passage the optical system images the pattern 130 onto the object being scanned 200 which here is a patient's set of teeth, and further images the object being scanned onto the image sensor 181.

The image sensor 181 has a color filter array 1000. Although drawn as a separate entity, the color filter array is typically integrated with the image sensor, with a single-color filter for every pixel.

5 The lens system includes a focusing element 151 which can be adjusted to shift the focal imaging plane of the pattern on the probed object 200. In the example embodiment, a single lens element is shifted physically back and forth along the optical axis.

10 As a whole, the optical system provides an imaging of the pattern onto the object being probed and from the object being probed to the camera.

The device may include polarization optics 160. Polarization optics can be used to selectively image specular reflections and block out undesired diffuse signal from
15 sub-surface scattering inside the scanned object. The beam splitter 140 may also have polarization filtering properties. It can be advantageous for optical elements to be anti-reflection coated.

The device may include folding optics, a mirror 170, which directs the light out of the
20 device in a direction different to the optical path of the lens system, e.g. in a direction perpendicular to the optical path of the lens system.

There may be additional optical elements in the scanner, for example one or more condenser lens in front of the light source 101.

25

In the example embodiment, the LED 101 is a multi-die LED with two green, one red, and one blue die. Only the green portion of the light is used for obtaining the surface geometry. Accordingly, the mirror 170 is coated such as to optimize preservation of the circular polarization of the green light, and not that of the other
30 colors. Note that during scanning all dies within the LED are active, i.e., emitting light, so the scanner emits apparently white light onto the scanned object 200. The

LED may emit light at the different colors with different intensities such that e.g. one color is more intense than the other colors. This may be desired in order to reduce cross-talk between the readings of the different color signals in the color image sensor. In case that the intensity of e.g. the red and blue diodes in a RGB system is reduced, the apparently white light emitted by the light source will appear greenish-white.

The scanner system further comprises a data processing system configured for deriving both surface geometry information and surface color information for a block of pixels of the color image sensor 180 at least partly from one 2D image recorded by said color image sensor 180. At least part of the data processing system may be arranged in the illustrated handheld part of the scanner system. A part may also be arranged in an additional part of the scanner system, such as a cart connected to the handheld part.

Figures 2A-2B shows an section of a prior art pattern generating element 130 that is applied as a static pattern in a spatial correlation embodiment of WO2010145669, as imaged on a monochromatic image sensor 180. The pattern can be a chrome-on-glass pattern. The section shows only a portion of the pattern is shown, namely one period. This period is represented by a pixel block of 6 by 6 image pixels, and 2 by 2 pattern fields. The fields drawn in gray in Fig. 2A are in actuality black because the pattern mask is opaque for these fields; gray was only chosen for visibility and thus clarity of the Figure. Fig. 2B illustrates the reference weights f for computing the spatial correlation measure A for the pixel block, where $n = 6 \times 6 = 36$, such that

$$A = \sum_{i=1}^n f_i I_i$$

where I are the intensity values measured in the 36 pixels in the pixel block for a given image. Note that perfect alignment between image sensor pixels and pattern fields is not required, but gives the best signal for the surface geometry measurement.

Figs. 3A-3B shows the extension of the principle in Figs. 2A-2B to color scanning. The pattern is the same as in Figs. 2A-2B and so is the image sensor geometry. However, the image sensor is a color image sensor with a Bayer color filter array. In Fig. 3A, pixels marked "B" have a blue color filter, while "G" indicates green and "R" red pixel filters, respectively. Fig. 3B shows the corresponding reference weights f . Note that only green pixels have a non-zero value. This is so because only the green fraction of the spectrum is used for recording the surface geometry information.

- 5
10 For the pattern/color filter combination of Figs. 3A-3B, a color component c_j within a pixel block can be obtained as

$$c_j = \sum_{i=1}^n g_{j,i} I_i$$

- where $g_{j,i} = 1$ if pixel i has a filter for color c_j , 0 otherwise. For an RGB color filter array like in the Bayer pattern, j is one of red, green, or blue. Further weighting of the individual color components, i.e., color calibration, may be required to obtain natural color data, typically as compensation for varying filter efficiency, illumination source efficiency, and different fraction of color components in the filter pattern. The calibration may also depend on focus plane location and/or position within the field of view, as the mixing of the LED's component colors may vary with those factors.

- 15
20 Figure 4 shows an inventive color filter array with a higher fraction of green pixels than in the Bayer pattern. The color filter array comprises a plurality of cells of 6x6 color filters, with blue color filters in positions (2,2) and (5,5) of each cell, red color filters in positions (2,5) and (5,2), and green color filters in all remaining positions of the cell.

- 25
Assuming that only the green portion of the illumination is used to obtain the surface geometry information, the filter of Figure 4 will potentially provide a better quality of the obtained surface geometry than a Bayer pattern filter, at the expense of poorer color representation. The poorer color representation will however in many cases

still be sufficient while the improved quality of the obtained surface geometry often is very advantageous.

5 Fig. 5 illustrates a flow chart 541 of a method of recording surface geometry and surface color of an object.

In step 542 a scanner system according to any of the previous claims is obtained.

10 In step 543 the object is illuminated with multichromatic probe light. In a focus scanning system utilizing a correlation measure or correlation measure function, a checkerboard pattern may be imposed on the probe light such that information relating to the pattern can be used for determining surface geometry information from captured 2D images.

15 In step 544 a series of 2D images of said object is captured using said color image sensor. The 2D images can be processed immediately or stored for later processing in a memory unit.

20 In step 545 both surface geometry information and surface color information are derived for a block of image sensor pixels at least partly from one captured 2D image. The information can e.g. be derived using the correlation measure approach as described herein. The derived informations are combined to generate a sub-scan of the object in step 546, where the sub-scan comprises data expressing the geometry and color of the object as seen from one view.

25

In step 547 a digital 3D representation expressing both color and geometry of the object is generated by combining several sub-scans. This may be done using known algorithms for sub-scan alignment such as algorithms for stitching and registration as widely known in the literature.

30

Figs. 6A-6C illustrates how surface geometry information and surface geometry information can be derived at least from one 2D image for a block of image sensor pixels.

5 The correlation measure is determined for all active image sensor pixel groups on the color image sensor for every focus plane position, i.e. for every 2D image of the stack. Starting by analyzing the 2D images from one end of the stack, the correlation measures for all active image sensor pixel groups is determined and the calculated values are stored. Progressing through the stack the correlation
10 measures for each pixel group are determined and stored together with the previously stored values, i.e. the values for the previously analyzed 2D images. A correlation measure function describing the variation of the correlation measure along the optical axis is then determined for each pixel group by smoothing and interpolating the determined correlation measure values. For example, a polynomial
15 can be fitted to the values of for a pixel block over several images on both sides of the recorded maximum, and a location of a deducted maximum can be found from the maximum of the fitted polynomial, which can be in between two images. The surface color information for the pixel group is derived from one or more of the 2D images from which the position of the correlation measure maximum was
20 determined i.e. surface geometry information and surface color information from a group of pixels of the color image sensor are derived from the same 2D images of the stack.

The surface color information can be derived from one 2D image. The maximum
25 value of the correlation measure for each group of pixels is monitored along the analysis of the 2D images such that when a 2D image has been analyzed the values for the correlation measure for the different pixels groups can be compared with the currently highest value for the previously analyzed 2D images. If the correlation measure is a new maximum value for that pixel group at least the portion
30 of the 2D image corresponding to this pixel group is saved. Next time a higher correlation value is found for that pixel group the portion of this 2D image is saved

overwriting the previously stored image/sub-image. Thereby when all 2D images of the stack have been analyzed, the surface geometry information of the 2D images is translated into a series of correlation measure values for each pixel group where a maximum value is recorded for each block of image sensor pixels.

5

Fig. 6A illustrated a portion 661 of a stack of 2D images acquired using a focus scanning system, where each 2D image is acquired at a different focal plane position. In each 2D image 662 a portion 663 corresponding to a block of image sensor pixels are indicated. The block corresponding to a set of coordinates (x_i, y_i) .
10 The focus scanning system is configured for determining a correlation measure for each block of image sensor pixels and for each 2D image in the stack. In Fig. 6B is illustrated the determined correlation measures 664 (here indicated by an "x") for the block 663. Based on the determined correlation measures 664 a correlation measure function 665 is calculated, here as a polynomial, and a maximum value for
15 the correlation measure function is found a position z_i . The z -value for which the fitted polynomial has a maximum (z_i) is identified as a point of the object surface. The surface geometry information derived for this block can then be presented in the form of the coordinates (x_i, y_i, z_i) , and by combining the surface geometry information for several block of the images sensor, the a sub-scan expressing the
20 geometry of part of the object can be created.

In Fig. 6C is illustrated a procedure for deriving the surface color geometry from two 2D images for each block of image sensor pixels. Two 2D images are stored using the procedure described above and their RGB values for the pixel block are
25 determined. In Fig. 6C the R-values 666 are displayed. An averaged R-value 667 (as well as averaged G- and B-values) at the z_i position can then be determined by interpolation and used as surface color information for this block. This surface ~~color~~
color information is evidently derived from the same 2D image that the geometry information at least in part was derived from.

30

Focus scanning apparatus recording color

Field of the application

- 5 The application relates to three dimensional (3D) scanning of the surface geometry and surface color of objects. A particular application is within dentistry, particularly for intraoral scanning.

Background

10

3D scanners are widely known from the art, and so are intraoral dental 3D scanners (e.g., Sirona Cerec, Cadent Itero, 3Shape TRIOS).

15 The ability to record surface color is useful in many applications. For example in dentistry, the user can differentiate types of tissue or detect existing restorations. For example in materials inspection, the user can detect surface abnormalities such as crystallization defects or discoloring. None of the above is generally possible from surface geometry information alone.

20 WO2010145669 mentions the possibility of recording color. In particular, several sequential images, each taken for an illumination in a different color - typically blue, green, and red - are combined to form a synthetic color image. This approach hence requires means to change light source color, such as color filters. Furthermore, in handheld use, the scanner will move relative to the scanned object
25 during the illumination sequence, reducing the quality of the synthetic color image.

Also US7698068 and US8102538 (Cadent Inc.) describe an intraoral scanner that records both geometry data and texture data with one or more image sensor(s). However, there is a slight delay between the color and the geometry recording,
30 respectively. US7698068 requires sequential illumination in different colors to form a synthetic image, while US8102538 mentions white light as a possibility, however from a second illumination source or recorded by a second image sensor, the first set being used for recording the geometry.

WO2012083967 discloses a scanner for recording geometry data and texture data with two separate cameras. While the first camera has a relatively shallow depth of field as to provide focus scanning based on multiple images, the second camera has a relatively large depth of field as to provide color texture information from a single image.

Color-recording scanning confocal microscopes are also known from the prior art (e.g., Keyence VK9700; see also JP2004029373). A white light illumination system along with a color image sensor is used for recording 2D texture, while a laser beam forms a dot that is scanned, i.e., moved over the surface and recorded by a photomultiplier, providing the geometry data from many depth measurements, one for each position of the dot. The principle of a moving dot requires the measured object not to move relative to the microscope during measurement, and hence is not suitable for handheld use.

Summary

One aspect of this application is to provide a scanner system and a method for recording surface geometry and surface color of an object, and where surface geometry and surface color are derived from the same captured 2D images.

One aspect of this application is to provide a scanner system for recording surface geometry and surface color of an object, and wherein all 2D images are captured using the same color image sensor.

One aspect of this application is to provide a scanner system and a method for recording surface geometry and surface color of an object, in which the information relating to the surface geometry and to the surface color are acquired simultaneously such that an alignment of data relating to the recorded surface geometry and data relating to the recorded surface color is not required in order to generate a digital 3D representation of the object expressing both color and geometry of the object.

Disclosed is a scanner system for recording surface geometry and surface color of an object, the scanner system comprising:

- a multichromatic light source configured for providing a multichromatic probe light for illumination of the object,
- 5 - a color image sensor comprising an array of image sensor pixels for capturing one or more 2D images of light received from said object, and
- a data processing system configured for deriving both surface geometry information and surface color information for a block of said image sensor pixels at least partly from one 2D image recorded by said color image sensor.

10

Disclosed is a method of recording surface geometry and surface color of an object, the method comprising:

- obtaining a scanner system comprising a multichromatic light source and a color image sensor comprising an array of image sensor pixels;
- 15 - illuminating the surface of said object with multichromatic probe light from said multichromatic light source;
- capturing a series of 2D images of said object using said color image sensor; and
- 20 - deriving both surface geometry information and surface color information for a block of said image sensor pixels at least partly from one captured 2D image.

In the context of the present application, the phrase “surface color” may refer to the apparent color of an object surface and thus in some cases, such as for semi-transparent or semi-translucent objects such as teeth, be caused by light from the object surface and/or the material below the object surface, such as material immediately below the object surface.

In the context of the present application, the phrase “derived at least partly from one 2D image” refers to the situation where the surface geometry information for a

30

given block of image sensor pixels at least in part is derived from one 2D image and where the corresponding surface color information at least in part is derived from the same 2D image. The phase also covers cases where the surface geometry information for a given block of image sensor pixels at least in part is derived from a plurality of 2D images of a series of captured 2D images and where the corresponding surface color information at least in part is derived from the same 2D images of that series of captured 2D images.

An advantage of deriving both surface geometry information and surface color information for a block of said image sensor pixels at least partly from one 2D image is that a scanner system having only one image sensor can be realized.

It is an advantage that the surface geometry information and the surface color information are derived at least partly from one 2D image, since this inherently provides that the two types of information are acquired simultaneously. There is hence no requirement for an exact timing of the operation of two color image sensors, which may the case when one image sensor is used for the geometry recording and another for color recording. Equally there is no need for an elaborate calculation accounting for significant differences in the timing of capturing of 2D images from which the surface geometry information is derived and the timing of the capturing of 2D images from which the surface color information is derived.

The present application discloses is a significant improvement over the state of the art in that only a single image sensor and a single multichromatic light source is required, and that surface color and surface geometry for at least a part of the object can be derived from the same 2D image or 2D images, which also means that alignment of color and surface geometry is inherently perfect. In the scanner system according to the present application, there is no need for taking into account or compensating for relative motion of the object and scanner system between obtaining surface geometry and surface color. Since the surface geometry and the surface color are obtained at precisely the same time, the scanner system automatically maintains its spatial disposition with respect to the object surface while obtaining the surface geometry and the surface color. This

makes the scanner system of the present application suitable for handheld use, for example as an intraoral scanner, or for scanning moving objects.

In some embodiments, the data processing system is configured for deriving surface geometry information and surface color information for said block of image sensor pixels from a series of 2D images, such as from a plurality of the 2D images in a series of captured 2D images. I.e. the data processing system is capable of analyzing a plurality of the 2D images in a series of captured 2D images in order to derive the surface geometry information for a block of image sensor pixels and to also derive surface color information from at least one of the 2D images from which the surface geometry information is derived.

In some embodiments, the data processing system is configured for deriving surface color information from a plurality of 2D images of a series of captured 2D images and for deriving surface geometry information from at least one of the 2D images from which the surface color information is derived.

In some embodiments, the data processing system is configured for deriving surface geometry information from a plurality of 2D images of a series of captured 2D images and for deriving surface color information from at least one of the 2D images from which the surface geometry information is derived.

In some embodiments, the set of 2D images from which surface color information is derived from is identical to the set of 2D images from which surface geometry information is derived from.

In some embodiments, the data processing system is configured for generating a sub-scan of a part of the object surface based on surface geometry information and surface color information derived from a plurality of blocks of image sensor pixels. The sub-scan expresses at least the geometry of the part of the object and typically one sub-scan is derived from one stack of captured 2D images.

In some embodiments, all 2D images of a captured series of images are analyzed to derive the surface geometry information for each block of image sensor pixels on the color image sensor.

5 For a given block of image sensor pixels the corresponding portions of the captured 2D images in the stack may be analyzed to derive the surface geometry information and surface color information for that block.

10 In some embodiments, the surface geometry information relates to where the object surface is located relative to the scanner system coordinate system for that particular block of image sensor pixels.

15 One advantage of the scanner system and the method of the current application is that the informations used for generating the sub-scan expressing both geometry and color of the object (as seen from one view) are obtained concurrently.

Sub-scans can be generated for a number of different views of the object such that they together cover the part of the surface.

20 In some embodiments, the data processing system is configured for combining a number of sub-scans to generate a digital 3D representation of the object. The digital 3D representation of the object then preferably expresses both the recorded geometry and color of the object.

25 The digital 3D representation of the object can be in the form of a data file. When the object is a patient's set of teeth the digital 3D representation of this set of teeth can e.g. be used for CAD/CAM manufacture of a physical model of the patient's set teeth.

30 The surface geometry and the surface color are both determined from light recorded by the color image sensor.

In some embodiments, the light received from the object originates from the multichromatic light source, i.e. it is probe light reflected or scattered from the surface of the object.

In some embodiments, the light received from the object comprises fluorescence excited by the probe light from the multichromatic light source, i.e. fluorescence emitted by fluorescent materials in the object surface.

5

In some embodiments, a second light source is used for the excitation of fluorescence while the multichromatic light source provides the light for obtaining the geometry and color of the object.

10 The scanner system preferably comprises an optical system configured for guiding light emitted by the multichromatic light source towards the object to be scanned and for guiding light received from the object to the color image sensor such that the 2D images of said object can be captured by said color image sensor.

15 In some embodiments, the scanner system comprises a first optical system, such as an arrangement of lenses, for transmitting the probe light from the multichromatic light source towards an object and a second optical system for imaging light received from the object at the color image sensor.

20 In some embodiments, single optical system images the probe light onto the object and images the object, or at least a part of the object, onto the color image sensor, preferably along the same optical axis, however in opposite directions along optical axis. The scanner may comprise at least one beam splitter located in the optical path, where the beam splitter is arranged such that it directs the probe
25 light from the multichromatic light source towards the object while it directs light received from the object towards the color image sensor.

Several scanning principles are suitable, such as triangulation and focus scanning.

30 In some embodiments, the scanner system is a focus scanner system operating by translating a focus plane along an optical axis of the scanner system and capturing the 2D images at different focus plane positions such that each series of captured 2D images forms a stack of 2D images. The focus plane position is

preferably shifted along an optical axis of the scanner system, such that 2D images captured at a number of focus plane positions along the optical axis forms said stack of 2D images for a given view of the object, i.e. for a given arrangement of the scanner system relative to the object. After changing the arrangement of the scanner system relative to the object a new stack of 2D images for that view can be captured. The focus plane position may be varied by means of at least one focus element, e.g., a moving focus lens.

In some focus scanner embodiments, the scanner system comprises a pattern generating element configured for incorporating a spatial pattern in said probe light.

In some embodiments, the pattern generating element is configured to provide that the probe light projected by scanner system onto the object comprises a pattern consisting of dark sections and sections with light having the a wavelength distribution according to the wavelength distribution of the multichromatic light source.

In some embodiments, the multichromatic light source comprises a broadband light source, such as a white light source

In some embodiments, the pixels of the color image sensor and the pattern generating element are configured to provide that each pixel corresponds to a single bright or dark region of the spatial pattern incorporated in said probe light.

For a focus scanner system the surface geometry information for a given block of image sensor pixels is derived by identifying at which distance from the scanner system the object surface is in focus for that block of image sensor pixels.

In some embodiments, deriving the surface geometry information and surface color information comprises calculating for several 2D images, such as for several 2D images in a captured stack of 2D images, a correlation measure between the portion of the 2D image captured by said block of image sensor pixels and a

weight function. Here the weight function is preferably determined based on information of the configuration of the spatial pattern. The correlation measure may be calculated for each 2D image of the stack.

- 5 The scanner system may comprise means for evaluating a correlation measure at each focus plane position between at least one image pixel and a weight function, where the weight function is determined based on information of the configuration of the spatial pattern.
- 10 In some embodiments, deriving the surface geometry information and the surface color information for a block of image sensor pixels comprises identifying the position along the optical axis at which the corresponding correlation measure has a maximum value. The position along the optical axis at which the corresponding correlation measure has a maximum value may coincide with the position where a
15 2D image has been captured but it may even more likely be in between two neighboring 2D images of the stack of 2D images.

Determining the surface geometry information may then relate to calculating a correlation measure of the spatially structured light signal provided by the pattern
20 with the variation of the pattern itself (which we term reference) for every location of the focus plane and finding the location of an extremum of this stack of 2D images. In some embodiments, the pattern is static. Such a static pattern can for example be realized as a chrome-on-glass pattern.

One way to define the correlation measure mathematically with a discrete set of
25 measurements is as a dot product computed from a signal vector, $I = (I_1, \dots, I_n)$, with $n > 1$ elements representing sensor signals and a reference vector, $f = (f_1, \dots, f_n)$, of reference weights. The correlation measure A is then given by

$$A = f \cdot I = \sum_{i=1}^n f_i I_i$$

The indices on the elements in the signal vector represent sensor signals that are recorded at different pixels, typically in a block of pixels. The reference vector f can be obtained in a calibration step.

5 By using knowledge of the optical system used in the scanner, it is possible to transform the location of an extremum of the correlation measure, i.e., the focus plane into depth data information, on a pixel block basis. All pixel blocks combined thus provide an array of depth data. In other words, depth is along an optical path that is known from the optical design and/or found from calibration, and each block of pixels on the image sensor represents the end point of an optical path.
10 Therefore, depth along an optical path, for a bundle of paths, yields a surface geometry within the field of view of the scanner, i.e. a sub-scan for the present view.

It can be advantageous to smooth and interpolate the series of correlation
15 measure values, such as to obtain a more robust and accurate determination of the location of the maximum.

In some embodiments, the generating a sub-scan comprises determining a correlation measure function describing the variation of the correlation measure along the optical axis for each block of image sensor pixels and identifying for the
20 position along the optical axis at which the correlation measure functions have their maximum value for the block.

In some embodiments, the maximum correlation measure value is the highest calculated correlation measure value for the block of image sensor pixels and/or
25 the highest maximum value of the correlation measure function for the block of image sensor pixels.

For example, a polynomial can be fitted to the values of A for a pixel block over several images on both sides of the recorded maximum, and a location of a
30 deducted maximum can be found from the maximum of the fitted polynomial, which can be in between two images. The deducted maximum is subsequently

used as depth data information when deriving the surface geometry from the present view, i.e. when deriving a sub-scan for the view.

5 In some embodiments, the data processing system is configured for determining a color for a point on a generated sub-scan based on the surface color information of the 2D image of the series in which the correlation measure has its maximum value for the corresponding block of image sensor pixels. The color may e.g. be read as the RGB values for pixels in said block of image sensor pixels.

10 In some embodiments, the data processing system is configured for deriving the color for a point on a generated sub-scan based on the surface color informations of the 2D images in the series in which the correlation measure has its maximum value for the corresponding block of image sensor pixels and on at least one additional 2D image, such as a neighboring 2D image from the series of captured
15 2D images. The surface color information is still derived from at least one of the 2D images from which the surface geometry information is derived.

In some embodiments, the data processing system is configured for interpolating surface color information of at least two 2D images in a series when determining
20 the sub-scan color, such as an interpolation of surface color information of neighboring 2D images in a series.

In some embodiments, the data processing system is configured for computing a smoothed color for a number of points of the sub-scan, where the computing
25 comprises an averaging of sub-scan colors of different points, such as a weighted averaging of the colors of the surrounding points on the sub-scan.

Surface color information for a block of image sensor pixels is at least partially derived from the same image from which surface geometry information is derived.
30 In case the location of the maximum of A is represented by a 2D image, then also color is derived from that same image. In case the location of the maximum of A is found by interpolation to be between two images, then at least one of those two

images should be used to derive color, or both images using interpolation for color also. It is also possible to average color data from more than two images used in the determination of the location of the maximum of the correlation measure, or to average color from a subset or superset of multiple images used to derive surface geometry. In any case, some image sensor pixels readings are used to derive both surface color and surface geometry for at least a part of the scanned object.

Typically, there are three color filters, so the overall color is composed of three contributions, such as red, green, and blue, or cyan, magenta, and yellow. Note that color filters typically allow a range of wavelengths to pass, and there is typically cross-talk between filters, such that, for example, some green light will contribute to the intensity measured in pixels with red filters.

For an image sensor with a color filter array, a color component c_j within a pixel block can be obtained as

$$c_j = \sum_{i=1}^n g_{j,i} I_i$$

where $g_{j,i} = 1$ if pixel i has a filter for color c_j , 0 otherwise. For an RGB filter array like in a Bayer pattern, j is one of red, green, or blue. Further weighting of the individual color components, i.e., color calibration, may be required to obtain natural color data, typically as compensation for varying filter efficiency, illumination source efficiency, and different fraction of color components in the filter pattern. The calibration may also depend on focus plane location and/or position within the field of view, as the mixing of the light source component colors may vary with those factors.

In some embodiments, surface color information is obtained for every pixel in a pixel block. In color image sensors with a color filter array or with other means to separate colors such as diffractive means, depending on the color measured with a particular pixel, an intensity value for that color is obtained. In other words, in this case a particular pixel has a color value only for one color. Recently developed color image sensors allow measurement of several colors in the same pixel, at different depths in the substrate, so in that case, a particular pixel can yield

intensity values for several colors. In summary, it is possible to obtain a resolution of the surface color data that is inherently higher than that of the surface geometry information.

5 In the embodiments where the resolution of the derived color is higher than the resolution of the surface geometry for the generated digital 3D representation of the object, a pattern will be visible when at least approximately in focus, which preferably is the case when color is derived. The image can be filtered such as to visually remove the pattern, however at a loss of resolution. In fact, it can be advantageous to be able to see the pattern for the user. For example in intraoral
10 scanning, it may be important to detect the position of a margin line, the rim or edge of a preparation. The image of the pattern overlaid on the geometry of this edge is sharper on a side that is seen approximately perpendicular, and more blurred on the side that is seen at an acute angle. Thus, a user, who in this example typically is a dentist or dental technician, can use the difference in sharpness to more precisely locate the position of the margin line than may be
15 possible from examining the surface geometry alone.

High spatial contrast of an in-focus pattern image on the object is desirable to obtain a good signal to noise ratio of the correlation measure on the color image sensor. Improved spatial contrast can be achieved by preferential imaging of the
20 specular surface reflection from the object on the color image sensor. Thus, some embodiments comprise means for preferential/selective imaging of specularly reflected light. This may be provided if the scanner further comprises means for polarizing the probe light, for example by means of at least one polarizing beam splitter.

25 In some embodiments, the polarizing optics is coated such as to optimize preservation of the circular polarization of a part of the spectrum of the multichromatic light source that is used for recording the surface geometry.

The scanner system may further comprise means for changing the polarization state of the probe light and/or the light received from the object. This can be
30 provided by means of a retardation plate, preferably located in the optical path. In some embodiments, the retardation plate is a quarter wave retardation plate.

Especially for intraoral applications where the scanned object e.g. is the patient's set or teeth, the scanner can have an elongated tip, with means for directing the probe light and/or imaging an object. This may be provided by means of at least one folding element. The folding element could be a light reflecting element such as a mirror or a prism. The probe light then emerges from the scanner system along an optical axis at least partly defined by the folding element.

For a more in-depth description of the focus scanning technology, see WO2010145669.

In some embodiments, the data processing system is configured for determining the color of a least one point of the generated digital 3D representation of the object, such that the digital 3D representation expresses both geometry and color profile of the object. Color may be determined for several points of the generated digital 3D representation such that the color profile of the scanned part of the object is expressed by the digital 3D representation.

In some embodiments determining the object color comprises computing a weighted average of color values derived for corresponding points in overlapping sub-scans at that point of the object surface. This weighted average can then be used as the color of the point in the digital 3D representation of the object.

In some embodiments the data processing system is configured for detecting saturated pixels in the captured 2D images and for mitigating or removing the error in the derived surface color information or the sub-scan color caused by the pixel saturation.

In some embodiments the error caused by the saturated pixel is mitigated or removed by assigning a low weight to the surface color information of the saturated pixel in the computing of the smoothed color of a sub-scan and/or by assigning a low weight to the color of a sub-scan computed based on the saturated pixel.

In some embodiments, the data processing system is configured for comparing the derived surface color information of sections of the captured 2D images and/or of the generated sub-scans of the object with predetermined color ranges for teeth and for oral tissue, and for suppressing the red component of the derived surface color information or sub-scan color for sections where the color is not in one of the two predetermined color ranges.

The scanner system disclosed here comprises a multichromatic light source, for example a white light source, for example a multi-die LED.

Light received from the scanned object, such as probe light returned from the object surface or fluorescence generated by the probe light by exciting fluorescent parts of the object, is recorded by the color image sensor. In some embodiments, the color image sensor comprises a color filter array such that every pixel in the color image sensor is a color-specific filter. The color filters are preferably arranged in a regular pattern, for example where the color filters are arranged according to a Bayer color filter pattern. The image data thus obtained are used to derive both surface geometry and surface color for each block of pixels. For a focus scanner utilizing a correlation measure, the surface geometry may be found from an extremum of the correlation measure as described above.

In some embodiments, the surface geometry is derived from light in a first part of the spectrum of the probe light provided by the multichromatic light source.

Preferably, the color filters are aligned with the image sensor pixels, preferably such that each pixel has a color filter for a particular color only.

In some embodiments, the color filter array is such that its proportion of pixels with color filters that match the first part of the spectrum is larger than 50%.

In some embodiments, the surface geometry information is derived from light in a selected wavelength range of the spectrum provided by the multichromatic light source. The light in the other wavelength ranges is hence not used to derive the surface geometry information. This provides the advantage that chromatic dispersion of optical elements in the optical system of the scanner system does not influence the scanning of the object.

It can be preferable to compute the surface geometry only from pixels with one or two types of color filters. A single color requires no achromatic optics and is thus provides for a scanner that is easier and cheaper to build. Furthermore, folding elements can generally not preserve the polarization state for all colors equally well. When only some color(s) is/are used to compute surface geometry, the reference vector f will contain zeros for the pixels with filters for the other color(s). Accordingly, the total signal strength is generally reduced, but for large enough blocks of pixels, it is generally still sufficient. Preferentially, the pixel color filters are adapted for little cross-talk from one color to the other(s). Note that even in the embodiments computing geometry from only a subset of pixels, color is preferably still computed from all pixels.

In some embodiments, the color image sensor comprises a color filter array comprising at least three types of colors filters, each allowing light in a known wavelength range, W_1 , W_2 , and W_3 respectively, to propagate through the color filter.

In some embodiments, the color filter array is such that its proportion of pixels with color filters that match the selected wavelength range of the spectrum is larger than 50%, such a wherein the proportion equals 32/36, 60/64 or 96/100.

In some embodiments, the selected wavelength range matches the W_2 wavelength range.

In some embodiments, the color filter array comprises a plurality of cells of 6x6 color filters, where the color filters in positions (2,2) and (5,5) of each cell are of the W_1 type, the color filters in positions (2,5) and (5,2) are of the W_3 type. Here a W_1 type of filter is a color filter that allows light in the known wavelength range W_1 to propagate through the color filter, and similar for W_2 and W_3 type of filters. In some embodiments, the remaining 32 color filters in the 6x6 cell are of the W_2 type.

In a RGB color system, W1 may correspond to red light, W2 to green light, and W3 to blue light.

- 5 In some embodiments, the scanner is configured to derive the surface color with a higher resolution than the surface geometry.

In some embodiments, the higher surface color resolution is achieved by demosaicing, where color values for pixel blocks may be demosaiced to achieve an apparently higher resolution of the color image than is present in the surface geometry. The demosaicing may operate on pixel blocks or individual pixels.

10

In case a multi-die LED or another illumination source comprising physically or optically separated light emitters is used, it is preferable to aim at a Köhler type illumination in the scanner, i.e. the illumination source is defocused at the object plane in order to achieve uniform illumination and good color mixing for the entire field of view. In case color mixing is not perfect and varies with focal plane location, color calibration of the scanner will be advantageous.

15

In some embodiments, the pattern generating element is configured to provide that the spatial pattern comprises alternating dark and bright regions arranged in a checkerboard pattern. The probe light provided by the scanner system then comprises a pattern consisting of dark sections and sections with light having the same wavelength distribution as the multichromatic light source.

20

In order to obtain a digital 3D representation expressing both surface geometry and color representation of an object, i.e. a colored digital 3D representation of said part of the object surface, typically several sub-scans, i.e. partial representations of the object, have to be combined, where each sub-scans presents one view of the object. A sub-scan expressing a view from a given relative position preferably records the geometry and color of the object surface as seen from that relative position.

25

For a focus scanner, a view corresponds to one pass of the focusing element(s), i.e. for a focus scanner each sub-scan is the surface geometry and color derived

30

from the stack of 2D images recorded during the pass of the focus plane position between its extremum positions.

The surface geometry found for various views can be combined by algorithms for stitching and registration as widely known in the literature, or from known view
5 positions and orientations, for example when the scanner is mounted on axes with encoders. Color can be interpolated and averaged by methods such as texture weaving, or by simply averaging corresponding color components in multiple views of the same location on the surface. Here, it can be advantageous to account for differences in apparent color due to different angles of incidence and reflection,
10 which is possible because the surface geometry is also known. Texture weaving is described by e.g. Callieri M, Cignoni P, Scopigno R. "Reconstructing textured meshes from multiple range rgb maps". VMV 2002, Erlangen, Nov 20-22, 2002.

In some embodiments, the scanner and/or the scanner system is configured for generating a sub-scan of the object surface based on the obtained surface color
15 and surface geometry.

In some embodiments, the scanner and/or the scanner system is configured for combining sub-scans of the object surface obtained from different relative positions to generate a digital 3D representation expressing the surface geometry and color of at least part of the object.

20 In some embodiments, the combination of sub-scans of the object to obtain the digital 3D representation expressing surface geometry and color comprises computing the color in each surface point as a weighted average of corresponding points in all overlapping sub-scans at that surface point. The weight of each sub-scan in the sum may be determined by several factors, such as the presence of
25 saturated pixel values or the orientation of the object surface with respect to the scanner when the sub-scan is recorded.

Such a weighted average is advantageous in cases where some scanner positions and orientations relative to the object will give a better estimate of the actual color than other positions and orientations. If the illumination of the object surface is
30 uneven this can to some degree also be compensated for by weighting the best illuminated parts higher.

In some embodiments, the data processing system of the scanner system comprises an image processor configured for performing a post-processing of the surface geometry, the surface color readings, or the derived sub-scan or the digital 3D representation of the object. The scanner system may be configured for performing the combination of the sub-scans using e.g. computer implemented algorithms executed by the image processor.

The scanner system may be configured for performing the combination of the sub-scans using e.g. computer implemented algorithms executed by the data processing system as part of the post-processing of the surface geometry, surface color, sub-scan and/or the digital 3D representation, i.e. the post-processing comprises computing the color in each surface point as a weighted average of corresponding points in all overlapping sub-scans at that surface point.

Saturated pixel values should preferably have a low weight to reduce the effect of highlights on the recording of the surface color. The color for a given part of the surface should preferably be determined primarily from 2D images where the color can be determined precisely which is not the case when the pixel values are saturated.

In some embodiments, the scanner and/or scanner system is configured for detecting saturated pixels in the captured 2D images and for mitigating or removing the error in the obtained color caused by the pixel saturation. The error caused by the saturated pixel may be mitigated or removed by assigning a low weight to the saturated pixel in the weighted average.

Specularly reflected light has the color of the light source rather than the color of the object surface. If the object surface is not a pure white reflector then specular reflections can hence be identified as the areas where the pixel color closely matches the light source color. When obtaining the surface color it is therefore advantageous to assign a low weight to pixels or pixel groups whose color values closely match the color of the multichromatic light source in order to compensate for such specular reflections.

Specular reflections may also be a problem when intra orally scanning a patient's set of teeth since teeth rarely are completely white. It may hence be advantageous

to assume that for pixels where the readings from the color images sensor indicate that the surface of the object is a pure white reflector, the light recorded by this pixel group is caused by a specular reflection from the teeth or the soft tissue in the oral cavity and accordingly assign a low weight to these pixels to compensate
5 for the specular reflections.

In some embodiments, the compensation for specular reflections from the object surface is based on information derived from a calibration of the scanner in which a calibration object e.g. in the form of a pure white reflector is scanned. The color image sensor readings then depend on the spectrum of the multichromatic light
10 source and on the wavelength dependence of the scanner's optical system caused by e.g. a wavelength dependent reflectance of mirrors in the optical system. If the optical system guides light equally well for all wavelengths of the multichromatic light source, the color image sensor will record the color (also referred to as the spectrum) of the multichromatic light source when the pure white reflector is
15 scanned.

In some embodiments, compensating for the specular reflections from the surface is based on information derived from a calculation based on the wavelength dependence of the scanner's optical system, the spectrum of the multichromatic light source and a wavelength dependent sensitivity of the color image sensor. In
20 some embodiments, the scanner comprises means for optically suppressing specularly reflected light to achieve better color measurement. This may be provided if the scanner further comprises means for polarizing the probe light, for example by means of at least one polarizing beam splitter.

When scanning inside an oral cavity there may be red ambient light caused by
25 probe light illumination of surrounding tissue, such as the gingiva, palette, tongue or buccal tissue. In some embodiments, the scanner and/or scanner system is hence configured for suppressing the red component in the recorded 2D images.

In some embodiments, the scanner and/or scanner system is configured for comparing the color of sections of the captured 2D images and/or of the sub-scans
30 of the object with predetermined color ranges for teeth and for oral tissue, respectively, and for suppressing the red component of the recorded color for

sections where the color is not in either one of the two predetermined color ranges. The teeth may e.g. be assumed to be primarily white with one ratio between the intensity of the different components of the recorded image, e.g. with one ratio between the intensity of the red component and the intensity of the blue and/or green components in a RGB configuration, while oral tissue is primarily reddish with another ratio between the intensity of the components. When a color recorded for a region of the oral cavity shows a ratio which differs from both the predetermined ratio for teeth and the predetermined ratio for tissue, this region is identified as a tooth region illuminated by red ambient light and the red component of the recorded image is suppressed relative to the other components, either by reducing the recorded intensity of the red signal or by increasing the recorded intensities of the other components in the image.

In some embodiments, the color of points with a surface normal directly towards the scanner are weighted higher than the color of points where the surface normal is not directed towards the scanner. This has the advantage that points with a surface normal directly towards the scanner will to a higher degree be illuminated by the white light from the scanner and not by the ambient light.

In some embodiments, the color of points with a surface normal directly towards the scanner are weighted lower if associated with specular reflections.

In some embodiments the scanner is configured for simultaneously compensating for different effects, such as compensating for saturated pixels and/or for specular reflections and/or for orientation of the surface normal. This may be done by generally raising the weight for a selection of pixels or pixel groups of a 2D image and by reducing the weight for a fraction of the pixels or pixel groups of said selection.

In some embodiments, the method comprises a processing of recorded 2D images, a sub-scan or the generated 3D representations of the part of the object, where said processing comprises

- compensating for pixel saturation by omitting or reducing the weight of saturated pixels when deriving the surface color, and/or

- compensating for specular reflections when deriving the surface color by omitting or reducing the weight of pixels whose color values closely matches the light source color, and/or
- compensating for red ambient light by comparing surface color information of the 2D images with predetermined color ranges, and suppressing the red component of the recorded color if this is not within a predetermined color range.

Disclosed is a method of using the disclosed scanner system to display color texture on the generated digital 3D representation of the object. It is advantageous to display the color data as a texture on the digital 3D representation, for example on a computer screen. The combination of color and geometry is a more powerful conveyor of information than either type of data alone. For example, dentists can more easily differentiate between different types of tissue. In the rendering of the surface geometry, appropriate shading can help convey the surface geometry on the texture, for example with artificial shadows revealing sharp edges better than texture alone could do.

When the multichromatic light source is a multi-die LED or similar, the scanner system can also be used to detect fluorescence. Disclosed is a method of using the disclosed scanner system to display fluorescence on surface geometry.

In some embodiments, the scanner is configured for exciting fluorescence on said object by illuminating it with only a subset of the LED dies in the multi-die LED, and where said fluorescence is recorded by only or preferentially reading out only those pixels in the color image sensor that have color filters at least approximately matching the color of the fluoresced light, i.e. measuring intensity only in pixels of the image sensors that have filters for longer-wavelength light. In other words, the scanner is capable of selectively activating only a subset of the LED dies in the multi-die LED and of only recording or preferentially reading out only those pixels in the color image sensor that have color filters at a higher wavelength than that of the subset of the LED dies, such that light emitted from the subset of LED dies can excite fluorescent materials in the object and the scanner can record the

fluorescence emitted from these fluorescent materials. The subset of the dies preferably comprises one or more LED dies which emits light within the excitation spectrum of the fluorescent materials in the object, such as an ultraviolet, a blue, a green, a yellow or a red LED die. Such fluorescence measurement yields a 2D data array much like the 2D color image, however unlike the 2D image it cannot be taken concurrently with the surface geometry. For a slow-moving scanner, and/or with appropriate interpolation, the fluorescence image can still be overlaid the surface geometry. It is advantageous to display fluorescence on teeth because it can help detect caries and plaque.

10 In some embodiments, the data processing system comprises a microprocessor unit configured for extracting the surface geometry information from 2D images obtained by the color image sensor and for determining the surface color from the same images.

The data processing system may comprise units distributed in different parts of the scanner system. For a scanner system comprising a handheld part connected to a stationary unit, the data processing system may for example comprise one unit integrated in the handheld part and another unit integrated in the stationary unit. This can be advantageous when a data connection for transferring data from the handheld unit to the stationary unit has a bandwidth which cannot handle the data stream from the color image sensor. A preliminary data processing in the handheld unit can then reduce the amount of data which must be transferred via the data connection.

25 In some embodiments, the data processing system comprises a computer readable medium on which is stored computer implemented algorithms for performing said post-processing.

In some embodiments, a part of the data processing system is integrated in a cart or a personal computer.

Disclosed is a method of using the disclosed scanner system to average color and/or surface geometry from several views, where each view represents a substantially fixed relative orientation of scanner and object.

5 Disclosed is a method using the disclosed scanner system to combine color and/or surface geometry from several views, where each view represents a substantially fixed relative orientation of scanner and object, such as to achieve a more complete coverage of the object than would be possible in a single view.

10 Disclosed is a scanner for obtaining surface geometry and surface color of an object, the scanner comprising:

- a multichromatic light source configured for providing a probe light, and
- a color image sensor comprising an array of image sensor pixels for recording one or more 2D images of light received from said object,

15 where at least for a block of said image sensor pixels, both surface color and surface geometry of a part of the object are derived at least partly from one 2D image recorded by said color image sensor

Disclosed is a scanner system for recording surface geometry and surface color of an object, the scanner system comprising:

- 20
- a multichromatic light source configured for providing a multichromatic probe light, and
 - a color image sensor comprising an array of image sensor pixels for capturing one or more 2D images of light received from said object,

25 where at least for a block of said image sensor pixels, both surface color information and surface geometry information of a part of the object are derived at least partly from one 2D image captured by said color image sensor.

Disclosed is a scanner system for recording surface geometry and surface color of an object, the scanner system comprising:

- a multichromatic light source configured for providing a probe light,
- a color image sensor comprising an array of image sensor pixels, and
- 5 - an optical system configured for guiding light received from the object to the color image sensor such that 2D images of said object can be captured by said color image sensor;

wherein the scanner system is configured for capturing a number of said 2D images of a part of the object and for deriving both surface color information and surface geometry information of the part of the object from at least one of said
10 captured 2D images at least for a block of said color image sensor pixels, such that the surface color information and the surface geometry information are obtained concurrently by the scanner.

15 Disclosed is a scanner system for recording surface geometry and surface color of an object, the scanner system comprising:

- a multichromatic light source configured for providing a probe light;
- a color image sensor comprising an array of image sensor pixels, where the image sensor is arranged to capture 2D images of light received
20 from the object; and
- an image processor configured for deriving both surface color information and surface geometry information of at least a part of the object from at least one of said 2D images captured by the color image sensor.

25

Disclosed is a scanner system for recording surface geometry and surface color of an object, said scanner system comprising

- a scanner system according to any of the embodiments, where the scanner system is configured for deriving surface color and surface geometry of the object, and optionally for generating a sub-scan or a digital 3D representation of the part of the object; and
- 5 - a data processing unit configured for post-processing surface geometry and/or surface color readings from the color image sensor, or for post-processing the generated sub-scan or digital 3D representation.

Disclosed is a method of recording surface geometry and surface color of an
10 object, the method comprising:

- providing a scanner or scanner system according to any of the embodiments;
- illuminating the surface of said object with probe light from said multichromatic light source;
- 15 - recording one or more 2D images of said object using said color image sensor; and
- deriving both surface color and surface geometry of a part of the object from at least some of said recorded 2D images at least for a block of said image sensor pixels, such that the surface color and surface
20 geometry are obtained concurrently by the scanner.

Brief description of drawings

Fig. 1 shows a handheld embodiment of a scanner system.

25 Fig. 2 shows prior art pattern generating means and associated reference weights.

Fig. 3 shows a pattern generating means and associated reference weights.

Fig. 4 shows a color filter array.

Fig. 5 shows a flow chart of a method.

Fig. 6 illustrates how surface geometry information and surface geometry information can be derived

- 5 Fig. 1 shows a handheld part of a scanner system with components inside a housing 100. The scanner comprises a tip which can be entered into a cavity, a multichromatic light source in the form of a multi-die LED 101, pattern generating element 130 for incorporating a spatial pattern in the probe light, a beam splitter 140, color image sensor 180 including an image sensor 181, electronics and
- 10 potentially other elements, an optical system typically comprising at least one lens, and the image sensor. The light from the light source 101 travels back and forth through the optical system 150. During this passage the optical system images the pattern 130 onto the object being scanned 200 which here is a patient's set of teeth, and further images the object being scanned onto the image sensor 181.
- 15 The image sensor 181 has a color filter array 1000. Although drawn as a separate entity, the color filter array is typically integrated with the image sensor, with a single-color filter for every pixel.

The lens system includes a focusing element 151 which can be adjusted to shift the focal imaging plane of the pattern on the probed object 200. In the example

20 embodiment, a single lens element is shifted physically back and forth along the optical axis.

As a whole, the optical system provides an imaging of the pattern onto the object being probed and from the object being probed to the camera.

The device may include polarization optics 160. Polarization optics can be used to

25 selectively image specular reflections and block out undesired diffuse signal from sub-surface scattering inside the scanned object. The beam splitter 140 may also have polarization filtering properties. It can be advantageous for optical elements to be anti-reflection coated.

The device may include folding optics, a mirror 170, which directs the light out of the device in a direction different to the optical path of the lens system, e.g. in a direction perpendicular to the optical path of the lens system.

5 There may be additional optical elements in the scanner, for example one or more condenser lens in front of the light source 101.

In the example embodiment, the LED 101 is a multi-die LED with two green, one red, and one blue die. Only the green portion of the light is used for obtaining the surface geometry. Accordingly, the mirror 170 is coated such as to optimize preservation of the circular polarization of the green light, and not that of the other colors. Note that during scanning all dies within the LED are active, i.e., emitting light, so the scanner emits apparently white light onto the scanned object 200. The LED may emit light at the different colors with different intensities such that e.g. one color is more intense than the other colors. This may be desired in order to reduce cross-talk between the readings of the different color signals in the color image sensor. In case that the intensity of e.g. the red and blue diodes in a RGB system is reduced, the apparently white light emitted by the light source will appear greenish-white.

10
15

The scanner system further comprises a data processing system configured for deriving both surface geometry information and surface color information for a block of pixels of the color image sensor 180 at least partly from one 2D image recorded by said color image sensor 180. At least part of the data processing system may be arranged in the illustrated handheld part of the scanner system. A part may also be arranged in an additional part of the scanner system, such as a cart connected to the handheld part.

20

25

Figure 2 shows a section of a prior art pattern generating element 130 that is applied as a static pattern in a spatial correlation embodiment of WO2010145669, as imaged on a monochromatic image sensor 180. The pattern can be a chrome-on-glass pattern. The section shows only a portion of the pattern is shown, namely one period. This period is represented by a pixel block of 6 by 6 image pixels, and 2 by 2 pattern fields. The fields drawn in gray in Fig. 2A are in actuality black

30

because the pattern mask is opaque for these fields; gray was only chosen for visibility and thus clarity of the Figure. Fig. 2B illustrates the reference weights f for computing the spatial correlation measure A for the pixel block, where $n = 6 \times 6 = 36$, such that

$$A = \sum_{i=1}^n f_i I_i$$

5 where I are the intensity values measured in the 36 pixels in the pixel block for a given image. Note that perfect alignment between image sensor pixels and pattern fields is not required, but gives the best signal for the surface geometry measurement.

Fig. 3 shows the extension of the principle in Fig. 2 to color scanning. The pattern is the same as in Fig. 2 and so is the image sensor geometry. However, the image sensor is a color image sensor with a Bayer color filter array. In Fig. 3A, pixels marked “B” have a blue color filter, while “G” indicates green and “R” red pixel filters, respectively. Fig. 3B shows the corresponding reference weights f . Note that only green pixels have a non-zero value. This is so because only the green fraction of the spectrum is used for recording the surface geometry information.

For the pattern/color filter combination of Fig. 3, a color component c_j within a pixel block can be obtained as

$$c_j = \sum_{i=1}^n g_{j,i} I_i$$

where $g_{j,i} = 1$ if pixel i has a filter for color c_j , 0 otherwise. For an RGB color filter array like in the Bayer pattern, j is one of red, green, or blue. Further weighting of the individual color components, i.e., color calibration, may be required to obtain natural color data, typically as compensation for varying filter efficiency, illumination source efficiency, and different fraction of color components in the filter pattern. The calibration may also depend on focus plane location and/or position within the field of view, as the mixing of the LED’s component colors may vary with those factors.

Figure 4 shows an inventive color filter array with a higher fraction of green pixels than in the Bayer pattern. The color filter array comprises a plurality of cells of 6x6 color filters, with blue color filters in positions (2,2) and (5,5) of each cell, red color filters in positions (2,5) and (5,2), and green color filters in all remaining positions of the cell.

Assuming that only the green portion of the illumination is used to obtain the surface geometry information, the filter of Figure 4 will potentially provide a better quality of the obtained surface geometry than a Bayer pattern filter, at the expense of poorer color representation. The poorer color representation will however in many cases still be sufficient while the improved quality of the obtained surface geometry often is very advantageous.

Fig. 5 illustrates a flow chart 541 of a method of recording surface geometry and surface color of an object.

In step 542 a scanner system according to any of the previous claims is obtained.

In step 543 the object is illuminated with multichromatic probe light. In a focus scanning system utilizing a correlation measure or correlation measure function, a checkerboard pattern may be imposed on the probe light such that information relating to the pattern can be used for determining surface geometry information from captured 2D images.

In step 544 a series of 2D images of said object is captured using said color image sensor. The 2D images can be processed immediately or stored for later processing in a memory unit.

In step 545 both surface geometry information and surface color information are derived for a block of image sensor pixels at least partly from one captured 2D image. The information can e.g. be derived using the correlation measure approach as described herein. The derived informations are combined to generate

a sub-scan of the object in step 546, where the sub-scan comprises data expressing the geometry and color of the object as seen from one view.

In step 547 a digital 3D representation expressing both color and geometry of the object is generated by combining several sub-scans. This may be done using
5 known algorithms for sub-scan alignment such as algorithms for stitching and registration as widely known in the literature.

Fig. 6 illustrates how surface geometry information and surface geometry information can be derived at least from one 2D image for a block of image sensor
10 pixels.

The correlation measure is determined for all active image sensor pixel groups on the color image sensor for every focus plane position, i.e. for every 2D image of the stack. Starting by analyzing the 2D images from one end of the stack, the correlation measures for all active image sensor pixel groups is determined and
15 the calculated values are stored. Progressing through the stack the correlation measures for each pixel group are determined and stored together with the previously stored values, i.e. the values for the previously analyzed 2D images.

A correlation measure function describing the variation of the correlation measure along the optical axis is then determined for each pixel group by smoothing and
20 interpolating the determined correlation measure values. For example, a polynomial can be fitted to the values of for a pixel block over several images on both sides of the recorded maximum, and a location of a deducted maximum can be found from the maximum of the fitted polynomial, which can be in between two images.

25 The surface color information for the pixel group is derived from one or more of the 2D images from which the position of the correlation measure maximum was determined i.e. surface geometry information and surface color information from a group of pixels of the color image sensor are derived from the same 2D images of the stack.

The surface color information can be derived from one 2D image. The maximum value of the correlation measure for each group of pixels is monitored along the analysis of the 2D images such that when a 2D image has been analyzed the values for the correlation measure for the different pixels groups can be compared
5 with the currently highest value for the previously analyzed 2D images. If the correlation measure is a new maximum value for that pixel group at least the portion of the 2D image corresponding to this pixel group is saved. Next time a higher correlation value is found for that pixel group the portion of this 2D image is saved overwriting the previously stored image/sub-image. Thereby when all 2D
10 images of the stack have been analyzed, the surface geometry information of the 2D images is translated into a series of correlation measure values for each pixel group where a maximum value is recorded for each block of image sensor pixels.

Fig. 6A illustrated a portion 661 of a stack of 2D images acquired using a focus scanning system, where each 2D image is acquired at a different focal plane
15 position. In each 2D image 662 a portion 663 corresponding to a block of image sensor pixels are indicated. The block corresponding to a set of coordinates (x_i, y_i) . The focus scanning system is configured for determining a correlation measure for each block of image sensor pixels and for each 2D image in the stack. In Fig. 6B is illustrated the determined correlation measures 664 (here indicated by an "x") for
20 the block 663. Based on the determined correlation measures 664 a correlation measure function 665 is calculated, here as a polynomial, and a maximum value for the correlation measure function is found a position z_i . The z-value for which the fitted polynomial has a maximum (z_i) is identified as a point of the object surface. The surface geometry information derived for this block can then be
25 presented in the form of the coordinates (x_i, y_i, z_i) , and by combining the surface geometry information for several block of the images sensor, the a sub-scan expressing the geometry of part of the object can be created.

In Fig. 6C is illustrated a procedure for deriving the surface color geometry from two 2D images for each block of image sensor pixels. Two 2D images are stored
30 using the procedure described above and their RGB values for the pixel block are determined. In Fig. 6C the R-values 666 are displayed. An averaged R-value 667 (as well as averaged G- and B-values) at the z_i position can then be determined by

interpolation and used as surface color information for this block. This surface color information is evidently derived from the same 2D image that the geometry information at least in part was derived from.

Claims

1. A scanner system for recording surface geometry and surface color of an object, the scanner system comprising:
 - 5 - a multichromatic light source configured for providing a multichromatic probe light for illumination of the object,
 - a color image sensor comprising an array of image sensor pixels for capturing one or more 2D images of light received from said object, and
 - 10 - a data processing system configured for deriving both surface geometry information and surface color information for a block of said image sensor pixels at least partly from one 2D image recorded by said color image sensor.
2. The scanner system according to claim 1, wherein the data processing
15 system is configured for deriving surface geometry information and surface color information for said block of image sensor pixels from a series of 2D images.
3. The scanner system according to claim 1 or 2, wherein the data processing
20 system is configured for generating a sub-scan of a part of the object surface based on surface geometry information and surface color information derived from a plurality of blocks of image sensor pixels.
4. The scanner system according to any of claims 1 to 3, wherein the data
25 processing system is configured for combining a number of sub-scans to generate a digital 3D representation of the object.
5. The scanner system according to any of claims 2 to 5, where the scanner
30 system is a focus scanner system operating by translating a focus plane along an optical axis of the scanner system and capturing the 2D images at different focus plane positions such that each series of captured 2D images forms a stack of 2D images.

6. The scanner system according to any of the preceding claims, where the scanner system comprises a pattern generating element configured for incorporating a spatial pattern in said probe light.
- 5 7. The scanner system according to any of the preceding claims, where deriving the surface geometry information and surface color information comprises calculating for several 2D images a correlation measure between the portion of the 2D image captured by said block of image sensor pixels and a weight function, where the weight function is determined based on
10 information of the configuration of the spatial pattern.
8. The scanner system according to the preceding claim, wherein deriving the surface geometry information and the surface color information for a block of image sensor pixels comprises identifying the position along the optical
15 axis at which the corresponding correlation measure has a maximum value.
9. The scanner system according to claim 7 or 8, wherein generating a sub-scan comprises determining a correlation measure function describing the variation of the correlation measure along the optical axis for each block of
20 image sensor pixels and identifying for the position along the optical axis at which the correlation measure functions have their maximum value for the block.
10. The scanner system according to the preceding claim, where the maximum
25 correlation measure value is the highest calculated correlation measure value for the block of image sensor pixels and/or the highest maximum value of the correlation measure function for the block of image sensor pixels
- 30 11. The scanner system according to any of the preceding claims, wherein the data processing system is configured for determining a sub-scan color for a point on a generated sub-scan based on the surface color information of the

2D image in the series in which the correlation measure has its maximum value for the corresponding block of image sensor pixels.

5 12. The scanner system according to the preceding claim, wherein the data processing system is configured for deriving the sub-scan color for a point on a generated sub-scan based on the surface color informations of the 2D images in the series in which the correlation measure has its maximum value for the corresponding block of image sensor pixels and on at least one additional 2D image, such as a neighboring 2D image from the series of captured 2D images..

15 13. The scanner system according to the preceding claim, where the data processing system is configured for interpolating surface color information of at least two 2D images in a series when determining the sub-scan color, such as an interpolation of surface color information of neighboring 2D images in a series.

20 14. The scanner system according to any of the preceding claims wherein the data processing system is configured for computing a smoothed sub-scan color for a number of points of the sub-scan, where the computing comprises an averaging of sub-scan colors of different points, such as a weighted averaging of the colors of the surrounding points on the sub-scan.

25 15. The scanner system according to any of the preceding claims, where the data processing system is configured for determining object color of a least one point of the generated digital 3D representation of the object, such that the digital 3D representation expresses both geometry and color profile of the object,..

30 16. The scanner system according to the previous claim, wherein determining the object color comprises computing a weighted average of sub-scan color values derived for corresponding points in overlapping sub-scans at that point of the object surface.

- 5 17. The scanner system according to any the previous claims, wherein the data processing system is configured for detecting saturated pixels in the captured 2D images and for mitigating or removing the error in the derived surface color information or the sub-scan color caused by the pixel saturation.
- 10 18. The scanner system according to the previous claim wherein the error caused by the saturated pixel is mitigated or removed by assigning a low weight to the surface color information of the saturated pixel in the computing of the smoothed sub-scan color and/or by assigning a low weight to the sub-scan color computed based on the saturated pixel.
- 15 19. The scanner system according to any any of the preceding claims, wherein the data processing system is configured for comparing the derived surface color information of sections of the captured 2D images and/or of the generated sub-scans of the object with predetermined color ranges for teeth and for oral tissue, and for suppressing the red component of the derived surface color information or sub-scan color for sections where the color is not in one of the two predetermined color ranges.
- 20 20. The scanner system according to any of the preceding claims where the color image sensor comprises a color filter array comprising at least three types of colors filters, each allowing light in a known wavelength range, W1, W2, and W3 respectively, to propagate through the color filter.
- 25 21. The scanner system according to any of the preceding claims where the surface geometry information is derived from light in a selected wavelength range of the spectrum provided by the multichromatic light source.
- 30 22. The scanner system according to the preceding claim where the color filter array is such that its proportion of pixels with color filters that match the

selected wavelength range of the spectrum is larger than 50%, such a wherein the proportion equals 32/36, 60/64 or 96/100.

- 5 23. The scanner system according to claim 21 or 22, wherein the selected wavelength range matches the W2 wavelength range.
- 10 24. The scanner system according to any of claims 21 to 23, wherein the color filter array comprises a plurality of cells of 6x6 color filters, where the color filters in positions (2,2) and (5,5) of each cell are of the W1 type, the color filters in positions (2,5) and (5,2) are of the W3 type
- 15 25. The scanner system according to the preceding claim, where the remaining 32 color filters in the 6x6 cell are of the W2 type.
- 20 26. The scanner according to the preceding claim where the pattern generating element is configured to provide that the spatial pattern comprises alternating dark and bright regions arranged in a checkerboard pattern.
- 25 27. A scanner system for recording surface geometry and surface color of an object, the scanner system comprising:
- a multichromatic light source configured for providing a multichromatic probe light, and
 - a color image sensor comprising an array of image sensor pixels for capturing one or more 2D images of light received from said object,
- where at least for a block of said image sensor pixels, both surface color information and surface geometry information of a part of the object are derived at least partly from one 2D image captured by said color image sensor.

30

28. A method of recording surface geometry and surface color of an object, the method comprising:

- obtaining a scanner system according to any of the previous claims;
- 5 - illuminating the surface of said object with multichromatic probe light from said multichromatic light source;
- capturing a series of 2D images of said object using said color image sensor; and
- 10 - deriving both surface geometry information and surface color information for a block of image sensor pixels at least partly from one captured 2D image.

Abstract

5 Disclosed are a scanner system and a method for recording surface geometry and surface color of an object where both surface geometry information and surface color information for a block of said image sensor pixels at least partly from one 2D image recorded by said color image sensor

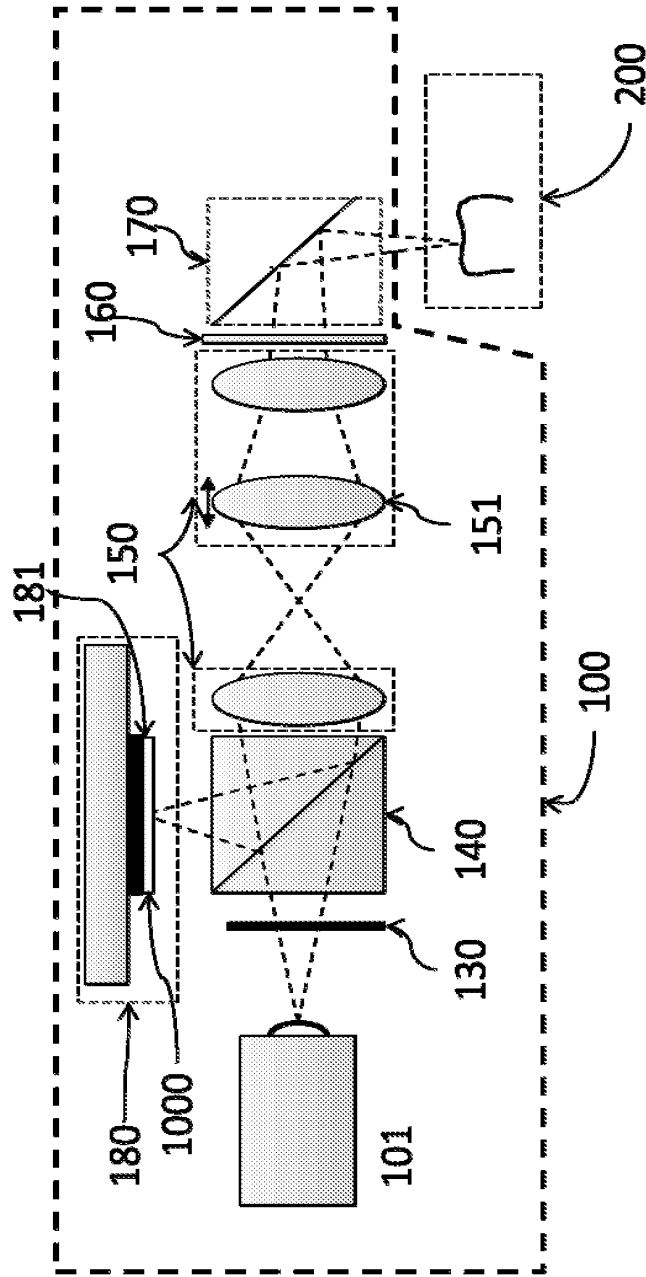

Fig. 1

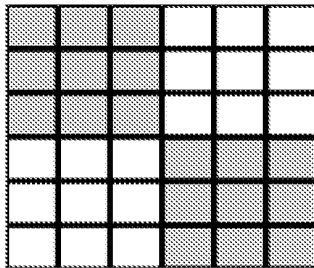

Fig. 2A

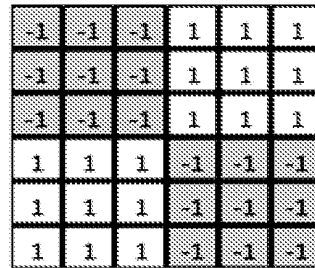

Fig. 2B

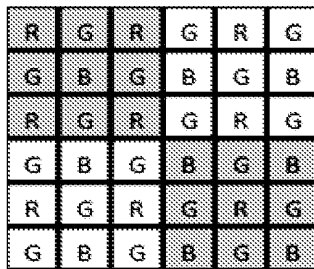

Fig. 3A

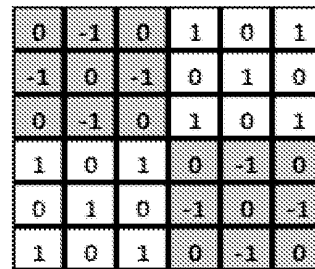

Fig. 3B

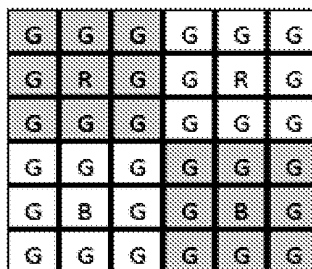

Fig. 4

541

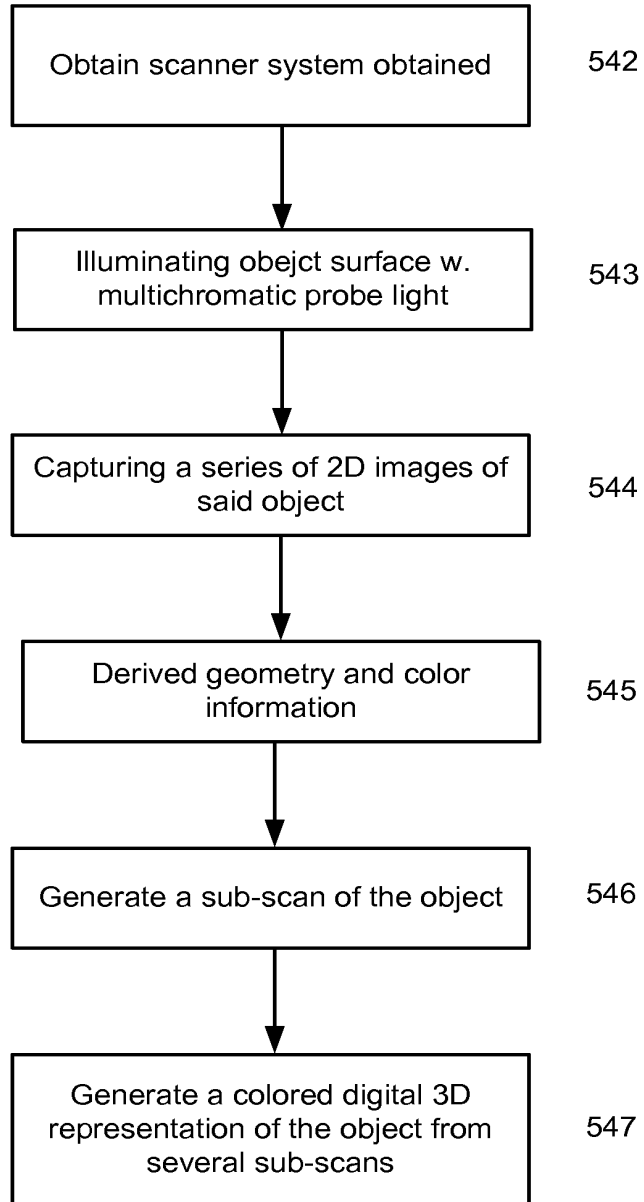
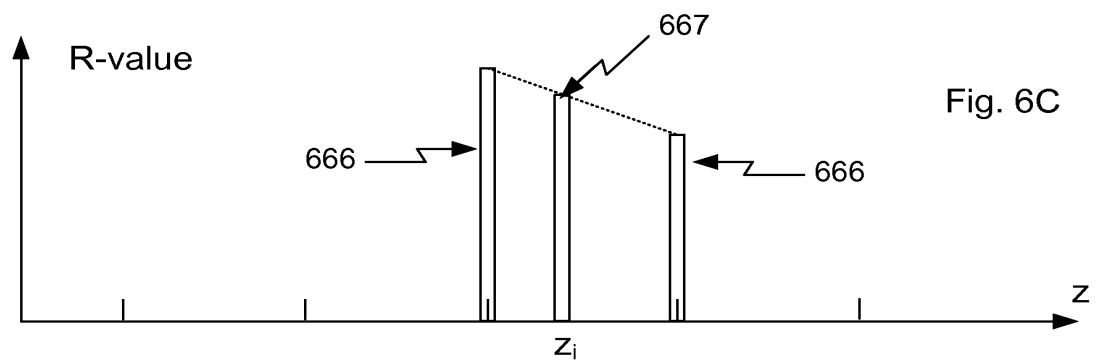
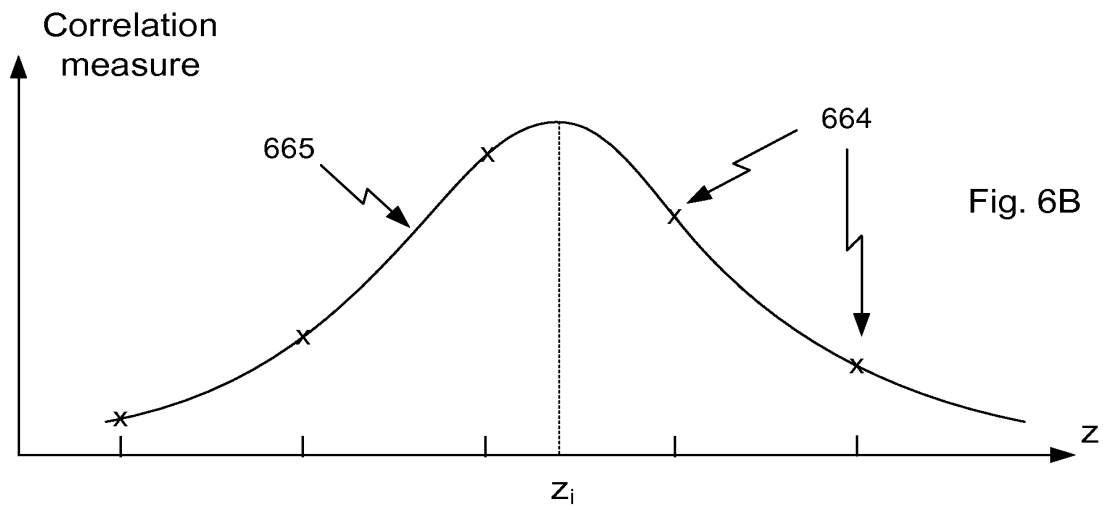
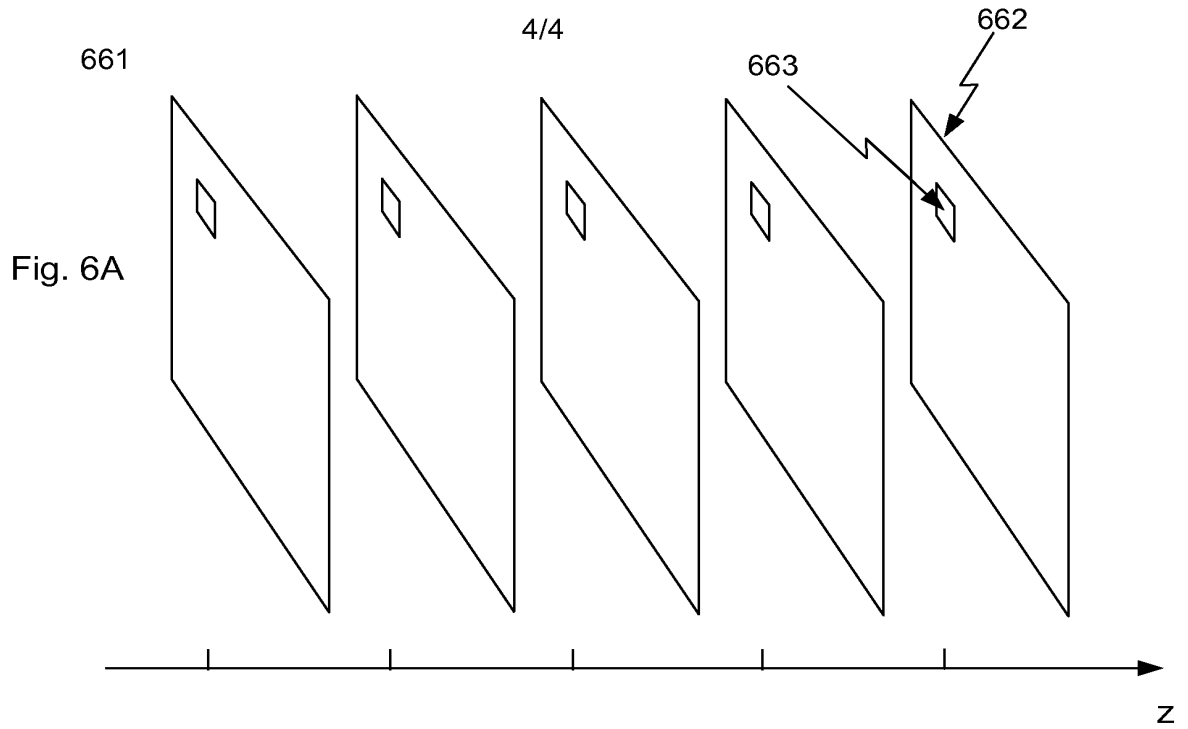

Fig. 5



From the INTERNATIONAL BUREAU

PCTNOTIFICATION OF RECEIPT OF
RECORD COPY

(PCT Rule 24.2(a))

To:

MÜNZER, Marc
Guardian IP Consulting I/S
Diplomvej, Building 381
DK-2800 Kgs. Lyngby
DANEMARK

Date of mailing (day/month/year) 24 February 2014 (24.02.2014)	IMPORTANT NOTIFICATION
Applicant's or agent's file reference P1439PC00	International application No. PCT/EP2014/052842

The applicant is hereby **notified** that the International Bureau has received the record copy of the international application as detailed below.

Name(s) of the applicant(s) and State(s) for which they are applicants:

3SHAPE A/S (all designated States)

International filing date: 13 February 2014 (13.02.2014)
Priority date(s) claimed: 13 February 2013 (13.02.2013)
13 February 2013 (13.02.2013)
Date of receipt of the record copy by the International Bureau: 20 February 2014 (20.02.2014)

List of designated Offices:

AP: BW, GH, GM, KE, LR, LS, MW, MZ, NA, RW, SD, SL, SZ, TZ, UG, ZM, ZW

EA: AM, AZ, BY, KG, KZ, RU, TJ, TM

EP: AL, AT, BE, BG, CH, CY, CZ, DE, DK, EE, ES, FI, FR, GB, GR, HR, HU, IE, IS, IT, LT, LU, LV, MC, MK, MT, NL, NO, PL, PT, RO, RS, SE, SI, SK, SM, TR

OA: BF, BJ, CF, CG, CI, CM, GA, GN, GQ, GW, KM, ML, MR, NE, SN, TD, TG

National: AE, AG, AL, AM, AO, AT, AU, AZ, BA, BB, BG, BH, BN, BR, BW, BY, BZ, CA, CH, CL, CN, CO, CR, CU, CZ, DE, DK, DM, DO, DZ, EC, EE, EG, ES, FI, GB, GD, GE, GH, GM, GT, HN, HR, HU, ID, IL, IN, IR, IS, JP, KE, KG, KN, KP, KR, KZ, LA, LC, LK, LR, LS, LT, LU, LY, MA, MD, ME, MG, MK, MN, MW, MX, MY, MZ, NA, NG, NI, NO, NZ, OM, PA, PE, PG, PH, PL, PT, QA, RO, RS, RU, RW, SA, SC, SD, SE, SG, SK, SL, SM, ST, SV, SY, TH, TJ, TM, TN, TR, TT, TZ, UA, UG, US, UZ, VC, VN, ZA, ZM, ZW

ATTENTION: The applicant should carefully check the data appearing in this Notification. In case of any discrepancy between these data and the indications in the international application, the applicant should immediately inform the International Bureau. **In addition, the applicant's attention is drawn to:**

- time limits for entry into the national phase (see www.wipo.int/pct/en/texts/time_limits.html and *PCT Applicant's Guide*, National Phase, especially Chapters 3 and 4)
- requirements regarding priority documents (if applicable) (see *PCT Applicant's Guide*, International Phase, paragraph 5.070)

A copy of this notification is being sent to the receiving Office and to the International Searching Authority.

The International Bureau of WIPO 34, chemin des Colombettes 1211 Geneva 20, Switzerland	Authorized officer Gagliardi Ghislaine e-mail pt05.pct@wipo.int Telephone No. +41 22 338 74 05
---	---

Facsimile No. +41 22 338 89 75

Form PCT/IB/301 (July 2010)

1/EWGUKERL37NF30

From the INTERNATIONAL BUREAU

PCT

NOTIFICATION CONCERNING SUBMISSION,
OBTENTION OR TRANSMITTAL
OF PRIORITY DOCUMENT

(PCT Administrative Instructions, Section 411)

To:

MÜNZER, Marc
Guardian IP Consulting I/S
Diplomvej, Building 381
DK-2800 Kgs. Lyngby
DANEMARK

Date of mailing (day/month/year) 16 April 2014 (16.04.2014)	
Applicant's or agent's file reference P1439PC00	IMPORTANT NOTIFICATION
International application No. PCT/EP2014/052842	International filing date (day/month/year) 13 February 2014 (13.02.2014)
International publication date (day/month/year) Not yet published	Priority date (day/month/year) 13 February 2013 (13.02.2013)
Applicant 3SHAPE A/S	

The applicant is hereby notified of the date of receipt (or of obtaining by the International Bureau) of the priority document(s) relating to all earlier application(s) whose priority is claimed. Unless otherwise indicated by the letters "NR", in the right-hand column or by an asterisk appearing next to the date of receipt, **the priority document concerned was submitted or transmitted to or obtained by the International Bureau in compliance with Rule 17.1(a), (b) or (b-bis)**. This Form replaces any previously issued notification concerning submission, transmittal or obtaining of priority documents.

<u>Priority date</u>	<u>Priority application No.</u>	<u>Country or regional Office or PCT receiving Office</u>	<u>Date of receipt of priority document</u>
13 February 2013 (13.02.2013)	PA 2013 70077	DK	11 April 2014 (11.04.2014)
13 February 2013 (13.02.2013)	61/764,178	US	11 April 2014 (11.04.2014)

The letters "NR" denote a priority document which, on the date of mailing of this Form, had not yet been received or obtained by the International Bureau in compliance with Rule 17.1(a), (b) or (b-bis). Where the applicant has failed to either submit, request to prepare and transmit, or to request the International Bureau to obtain the priority document within the applicable time limit under that Rule, the attention of the applicant is directed to Rule 17.1(c) which provides that no designated Office may disregard the priority claim concerned before giving the applicant an opportunity, upon entry into the national phase, to furnish the priority document within a time limit which is reasonable under the circumstances.

An asterisk "*" next to a date of receipt, denotes a priority document submitted or transmitted to or obtained by the International Bureau but not in compliance with Rule 17.1(a), (b) or (b-bis) (the priority document was received after the time limit prescribed in Rule 17.1(a); the request to prepare and transmit the priority document was submitted to the receiving Office after the applicable time limit under Rule 17.1(b) or the request to the International Bureau to obtain the priority document was made after the applicable time limit under Rule 17.1(b-bis)). Even though the priority document was not furnished in compliance with Rule 17.1(a), (b) or (b-bis), the International Bureau will nevertheless transmit a copy of the document to the designated Offices, for their consideration. In case such a copy is not accepted by the designated Office as the priority document, Rule 17.1(c) provides that no designated Office may disregard the priority claim concerned before giving the applicant an opportunity, upon entry into the national phase, to furnish the priority document within a time limit which is reasonable under the circumstances.

The International Bureau of WIPO 34, chemin des Colombettes 1211 Geneva 20, Switzerland	Authorized officer Nora Lindner e-mail pt05.pct@wipo.int Telephone No. +41 22 338 74 05
Facsimile No. +41 22 338 89 75	



From the INTERNATIONAL BUREAU

PCT

FIRST NOTICE INFORMING THE APPLICANT OF
THE COMMUNICATION OF THE INTERNATIONAL
APPLICATION (TO DESIGNATED OFFICES WHICH
DO NOT APPLY THE 30 MONTH TIME LIMIT
UNDER ARTICLE 22(1))

(PCT Rule 47.1(c))

To:

MÜNZER, Marc
Guardian IP Consulting I/S
Diplomvej, Building 381
DK-2800 Kgs. Lyngby
DANEMARK

Date of mailing (day/month/year) 18 September 2014 (18.09.2014)		
Applicant's or agent's file reference P1439PC00		IMPORTANT NOTICE
International application No. PCT/EP2014/052842	International filing date (day/month/year) 13 February 2014 (13.02.2014)	Priority date (day/month/year) 13 February 2013 (13.02.2013)
Applicant 3SHAPE A/S		

1. **ATTENTION:** For any designated Office(s), for which the time limit under Article 22(1), as in force from 1 April 2002 (30 months from the priority date), **does apply**, please see Form PCT/IB/308(Second and Supplementary Notice) (to be issued promptly after the expiration of 28 months from the priority date).

2. Notice is hereby given that the following designated Office(s), for which the time limit under Article 22(1), as in force from 1 April 2002, **does not apply**, has/have requested that the communication of the international application, as provided for in Article 20, be effected under Rule 93bis.1. The International Bureau has effected that communication on the date indicated below:
21 August 2014 (21.08.2014)

None

In accordance with Rule 47.1(c-bis)(i), those Offices will accept the present notice as conclusive evidence that the communication of the international application has duly taken place on the date of mailing indicated above and no copy of the international application is required to be furnished by the applicant to the designated Office(s).

3. The following designated Offices, for which the time limit under Article 22(1), as in force from 1 April 2002, **does not apply**, have not requested, as at the time of mailing of the present notice, that the communication of the international application be effected under Rule 93bis.1 :

LU, TZ, UG

In accordance with Rule 47.1(c-bis)(ii), those Offices accept the present notice as conclusive evidence that the Contracting State for which that Office acts as a designated Office does not require the furnishing, under Article 22, by the applicant of a copy of the international application.

4. TIME LIMITS for entry into the national phase

For the designated Office(s) listed above, and unless a demand for international preliminary examination has been filed before the expiration of **19 months** from the priority date (see Article 39(1)), the applicable time limit for entering the national phase will, **subject to what is said in the following paragraph**, be **20 MONTHS** from the priority date.

In practice, **time limits other than the 20-month time limit** will continue to apply, for various periods of time, in respect of certain of the designated Offices listed above. For **regular updates on the applicable time limits** (20 or 21 months, or other time limit), Office by Office, refer to the *PCT Gazette*, the *PCT Newsletter* and the *PCT Applicant's Guide*, Volume II, National Chapters, all available from WIPO's Internet site, at <http://www.wipo.int/pct/en/index.html>.

It is the applicant's **sole responsibility** to monitor all these time limits.

The International Bureau of WIPO 34, chemin des Colombettes 1211 Geneva 20, Switzerland	Authorized officer Nora Lindner
Facsimile No. +41 22 338 82 70	e-mail: pt05.pct@wipo.int



From the INTERNATIONAL BUREAU

PCT

SECOND AND SUPPLEMENTARY NOTICE
INFORMING THE APPLICANT OF THE
COMMUNICATION OF THE INTERNATIONAL
APPLICATION (TO DESIGNATED OFFICES
WHICH APPLY THE 30 MONTH TIME
LIMIT UNDER ARTICLE 22(1))

(PCT Rule 47.1(c))

To:

MÜNZER, Marc
Guardian IP Consulting I/S
Diplomvej, Building 381
DK-2800 Kgs. Lyngby
DANEMARK

Date of mailing (<i>day/month/year</i>) 18 June 2015 (18.06.2015)		
Applicant's or agent's file reference P1439PC00		IMPORTANT NOTICE
International application No. PCT/EP2014/052842	International filing date (<i>day/month/year</i>) 13 February 2014 (13.02.2014)	Priority date (<i>day/month/year</i>) 13 February 2013 (13.02.2013)
Applicant 3SHAPE A/S		

1. **ATTENTION:** For any designated Office(s), for which the time limit under Article 22(1), as in force from 1 April 2002 (30 months from the priority date), **does not apply**, please see Form PCT/IB/308(First Notice) issued previously.

2. Notice is hereby given that the following designated Office(s), for which the time limit under Article 22(1), as in force from 1 April 2002, **does apply**, has/have requested that the communication of the international application, as provided for in Article 20, be effected under Rule 93bis.1. The International Bureau has effected that communication on the date indicated below:
21 August 2014 (21.08.2014)

AZ, BY, CN, EP, HU, KG, KP, KR, MD, MK, MZ, NA, NG, PG, RU, SY, TM

In accordance with Rule 47.1(c-bis)(i), those Offices will accept the present notice as conclusive evidence that the communication of the international application has duly taken place on the date of mailing indicated above and no copy of the international application is required to be furnished by the applicant to the designated Office(s).

3. The following designated Offices, for which the time limit under Article 22(1), as in force from 1 April 2002, **does apply**, have not requested, as at the time of mailing of the present notice, that the communication of the international application be effected under Rule 93bis.1 :

AE, AG, AL, AM, AO, AP, AT, AU, BA, BB, BG, BH, BN, BR, BW, BZ, CA, CH, CL, CO, CR, CU, CZ, DE, DK, DM, DO, DZ, EA, EC, EE, EG, ES, FI, GB, GD, GE, GH, GM, GT, HN, HR, ID, IL, IN, IR, IS, JP, KE, KN, KZ, LA, LC, LK, LR, LS, LT, LY, MA, ME, MG, MN, MW, MX, MY, NI, NO, NZ, OA, OM, PA, PE, PH, PL, PT, QA, RO, RS, RW, SA, SC, SD, SE, SG, SK, SL, SM, ST, SV, TH, TJ, TN, TR, TT, UA, US, UZ, VC, VN, ZA, ZM, ZW

In accordance with Rule 47.1(c-bis)(ii), those Offices accept the present notice as conclusive evidence that the Contracting State for which that Office acts as a designated Office does not require the furnishing, under Article 22, by the applicant of a copy of the international application.

4. **TIME LIMITS for entry into the national phase**

For the designated or elected Office(s) listed above, the applicable time limit for entering the national phase will, **subject to what is said in the following paragraph**, be **30 MONTHS** from the priority date.

In practice, **time limits other than the 30-month time limit** will continue to apply, for various periods of time, in respect of certain of the designated or elected Office(s) listed above. For **regular updates on the applicable time limits** (30 or 31 months, or other time limit), Office by Office, refer to the *PCT Gazette*, the *PCT Newsletter* and the *PCT Applicant's Guide*, Volume II, National Chapters, all available from WIPO's Internet site, at <http://www.wipo.int/pct/en/index.html>.

It is the applicant's **sole responsibility** to monitor all these time limits.

The International Bureau of WIPO 34, chemin des Colombettes 1211 Geneva 20, Switzerland	Authorized officer Nora Lindner
Facsimile No. +41 22 338 82 70	e-mail: pt05.pct@wipo.int

IN THE UNITED STATES PATENT AND TRADEMARK OFFICE

In re Patent Application of)	
Bo ESBECH et al.)	Group Art Unit: Unassigned
Application No.: Unassigned)	Confirmation No.: Unassigned
Filed: July 28, 2015)	
For: FOCUS SCANNING APPARATUS)	
RECORDING COLOR)	
)	
)	

FIRST INFORMATION DISCLOSURE STATEMENT

Commissioner for Patents
P.O. Box 1450
Alexandria, VA 22313-1450

Commissioner:

In accordance with the duty of disclosure as set forth in 37 C.F.R. § 1.56, the accompanying information is being submitted in accordance with 37 C.F.R. §§ 1.97 and 1.98.

The relevance of the listed documents is their citation in the attached International Search Report in the corresponding PCT application, and/or in the present application.

To assist the Examiner, the documents are listed on the attached citation form. It is respectfully requested that an Examiner initialed copy of this form be returned to the undersigned.

Respectfully submitted,

BUCHANAN INGERSOLL & ROONEY PC

Date: July 28, 2015

By: *T.D. Boone*
Travis D. Boone
Registration No. 52635

Customer Number 21839
703 836 6620

Under the Paperwork Reduction Act of 1995, no persons are required to respond to a collection of information unless it contains a valid OMB control number.

Substitute for form 1449/PTO INFORMATION DISCLOSURE STATEMENT BY APPLICANT (Use as many sheets as necessary)			Complete if Known			
			Application Number		Unassigned	
			Filing Date		July 28, 2015	
			First Named Inventor		Bo ESBECH et al.	
			Art Unit		Unassigned	
			Examiner Name		Unassigned	
Sheet	1	of	1	Attorney Docket Number	0079124-000111	

U.S. PATENT DOCUMENTS					
Examiner Initials ⁷	Cite No. ¹	Document Number	Publication Date MM-DD-YYYY	Name of Patentee or Applicant of Cited Document	Pages, Columns, Lines, Where Relevant Passages or Relevant Figures Appear
		Number-Kind Code ² (if known)			
		US-2012/0075425 A1	03-29-2012	Thiel	
		US-2012/0092461 A1	04-19-2012	Fisker et al. (corr. to WO 2010/145669 below)	
		US-2014/0022356 A1	01-23-2014	Fisker et al. (corr. to WO 2012//083967 below)	
		US-7,698,068 B2	04-13-2010	Babayoff	
		US-8,102,538 B2	01-24-2012	Babayoff	
		US-2011/0221880 A1	09-15-2011	Liang et al. (corr. to EP 2241248 below)	
		US-2005/0285027 A1	12-29-2005	Favalora et al.	
		US-2012/0140243 A1	06-07-2012	Colonna de Lega	
		US-2014/0146142 S2	05-29-2014	Duret et al. (corr. to WO 2013/008097 below)	
		US-			
		US-			
		US-			
		US-			

FOREIGN PATENT DOCUMENTS						
Examiner Initials ⁷	Cite No. ¹	Foreign Patent Document	Publication Date MM-DD-YYYY	Name of Patentee or Applicant of Cited Document	Pages, Columns, Lines, Where Relevant Passages or Relevant Figures Appear	T ⁶
		Country Code ³ Number ⁴ Kind Code ⁵ (if known)				
		WO 2010/145669 A1	12-23-2010	3SHAPE A/S		
		WO 2012/083967 A1	06-28-2012	3SHAPE A/S		
		JP 2004-029373 A (w/English abstract)	01-29-2004	KEYENCE CO LTD		
		EP 2 241 248 A2	10-20-2010	CARESTREAM HEALTH INC		
		WO 2013/008097 A1	01-17-2013	DURET FRANCOIS		

NON PATENT LITERATURE DOCUMENTS			
Examiner Initials [*]	Cite No. ¹	Include name of the author (in CAPITAL LETTERS), title of the article (when appropriate), title of the item (book, magazine, journal, serial, symposium, catalog, etc.), date, page(s), volume-issue number(s), publisher, city and/or country where published.	T ²
		International Search Report (PCT/ISA/210) mailed on July 7, 2014, by the European Patent Office as the International Searching Authority for International Application No. PCT/EP2014/052842.	

Examiner Signature	Date Considered
--------------------	-----------------

^{*}EXAMINER: Initial if reference considered, whether or not citation is in conformance with MPEP 609. Draw line through citation if not in conformance and not considered. Include copy of this form with next communication to applicant. ¹ Applicant's unique citation designation number (optional). ² See Kinds Codes of USPTO Patent Documents at www.uspto.gov or MPEP 901.04. ³ Enter Office that issued the document, by the two-letter code (WIPO Standard ST.3). ⁴ For Japanese patent documents, the indication of the year of the reign of the Emperor must precede the serial number of the patent document. ⁵ Kind of document by the appropriate symbols as indicated on the document under WIPO Standard ST.16 if possible. ⁶ Applicant is to place a check mark here if English language Translation is attached.

PATENT COOPERATION TREATY

PCT

INTERNATIONAL SEARCH REPORT

(PCT Article 18 and Rules 43 and 44)

Applicant's or agent's file reference P1439PC00	FOR FURTHER ACTION		see Form PCT/ISA/220 as well as, where applicable, item 5 below.
International application No. PCT/EP2014/052842	International filing date (<i>day/month/year</i>) 13 February 2014 (13-02-2014)	(Earliest) Priority Date (<i>day/month/year</i>) 13 February 2013 (13-02-2013)	
Applicant 3SHAPE A/S			

This international search report has been prepared by this International Searching Authority and is transmitted to the applicant according to Article 18. A copy is being transmitted to the International Bureau.

This international search report consists of a total of 5 sheets.

It is also accompanied by a copy of each prior art document cited in this report.

1. Basis of the report

a. With regard to the **language**, the international search was carried out on the basis of:

- the international application in the language in which it was filed
- a translation of the international application into _____, which is the language of a translation furnished for the purposes of international search (Rules 12.3(a) and 23.1(b))

b. This international search report has been established taking into account the **rectification of an obvious mistake** authorized by or notified to this Authority under Rule 91 (Rule 43.6*bis*(a)).

c. With regard to any **nucleotide and/or amino acid sequence** disclosed in the international application, see Box No. I.

2. **Certain claims were found unsearchable** (See Box No. II)

3. **Unity of invention is lacking** (see Box No III)

4. With regard to the **title**,

- the text is approved as submitted by the applicant
- the text has been established by this Authority to read as follows:

5. With regard to the **abstract**,

- the text is approved as submitted by the applicant
- the text has been established, according to Rule 38.2, by this Authority as it appears in Box No. IV. The applicant may, within one month from the date of mailing of this international search report, submit comments to this Authority

6. With regard to the **drawings**,

- a. the figure of the **drawings** to be published with the abstract is Figure No. 1
 - as suggested by the applicant
 - as selected by this Authority, because the applicant failed to suggest a figure
 - as selected by this Authority, because this figure better characterizes the invention
- b. none of the figures is to be published with the abstract

INTERNATIONAL SEARCH REPORT

International application No.
PCT/EP2014/052842

Box No. II Observations where certain claims were found unsearchable (Continuation of item 2 of first sheet)

This international search report has not been established in respect of certain claims under Article 17(2)(a) for the following reasons:

1. Claims Nos.:
because they relate to subject matter not required to be searched by this Authority, namely:

2. Claims Nos.:
because they relate to parts of the international application that do not comply with the prescribed requirements to such an extent that no meaningful international search can be carried out, specifically:

3. Claims Nos.:
because they are dependent claims and are not drafted in accordance with the second and third sentences of Rule 6.4(a).

Box No. III Observations where unity of invention is lacking (Continuation of item 3 of first sheet)

This International Searching Authority found multiple inventions in this international application, as follows:

see additional sheet

1. As all required additional search fees were timely paid by the applicant, this international search report covers all searchable claims.

2. As all searchable claims could be searched without effort justifying an additional fees, this Authority did not invite payment of additional fees.

3. As only some of the required additional search fees were timely paid by the applicant, this international search report covers only those claims for which fees were paid, specifically claims Nos.:

4. No required additional search fees were timely paid by the applicant. Consequently, this international search report is restricted to the invention first mentioned in the claims; it is covered by claims Nos.:

1-18, 20-28

Remark on Protest

- The additional search fees were accompanied by the applicant's protest and, where applicable, the payment of a protest fee.
- The additional search fees were accompanied by the applicant's protest but the applicable protest fee was not paid within the time limit specified in the invitation.
- No protest accompanied the payment of additional search fees.

INTERNATIONAL SEARCH REPORT

International application No
PCT/EP2014/052842

A. CLASSIFICATION OF SUBJECT MATTER
INV. A61C9/00 G01B11/25
ADD.

According to International Patent Classification (IPC) or to both national classification and IPC

B. FIELDS SEARCHED

Minimum documentation searched (classification system followed by classification symbols)
A61C G01B

Documentation searched other than minimum documentation to the extent that such documents are included in the fields searched

Electronic data base consulted during the international search (name of data base and, where practicable, search terms used)

EPO-Internal, WPI Data

C. DOCUMENTS CONSIDERED TO BE RELEVANT

Category*	Citation of document, with indication, where appropriate, of the relevant passages	Relevant to claim No.
X	US 2012/075425 A1 (THIEL FRANK [DE]) 29 March 2012 (2012-03-29) cited in the application	1-6,15, 20-28
Y A	paragraphs [0004], [0032] - [0050], [0077] - [0085]; figure 1 -----	7-14,16 17,18
Y	WO 2010/145669 A1 (3SHAPE AS [DK]; FISKER RUNE [DK]; OEJELUND HENRIK [DK]; KJAER RASMUS []) 23 December 2010 (2010-12-23) the whole document -----	7-14,16
A	WO 2012/083967 A1 (3SHAPE AS [DK]; FISKER RUNE [DK]; VAN DER POEL MIKE [DK]) 28 June 2012 (2012-06-28) cited in the application the whole document -----	1

Further documents are listed in the continuation of Box C.

See patent family annex.

* Special categories of cited documents :

"A" document defining the general state of the art which is not considered to be of particular relevance

"E" earlier application or patent but published on or after the international filing date

"L" document which may throw doubts on priority claim(s) or which is cited to establish the publication date of another citation or other special reason (as specified)

"O" document referring to an oral disclosure, use, exhibition or other means

"P" document published prior to the international filing date but later than the priority date claimed

"T" later document published after the international filing date or priority date and not in conflict with the application but cited to understand the principle or theory underlying the invention

"X" document of particular relevance; the claimed invention cannot be considered novel or cannot be considered to involve an inventive step when the document is taken alone

"Y" document of particular relevance; the claimed invention cannot be considered to involve an inventive step when the document is combined with one or more other such documents, such combination being obvious to a person skilled in the art

"&" document member of the same patent family

Date of the actual completion of the international search

17 April 2014

Date of mailing of the international search report

07/07/2014

Name and mailing address of the ISA/
European Patent Office, P.B. 5818 Patentlaan 2
NL - 2280 HV Rijswijk
Tel. (+31-70) 340-2040,
Fax: (+31-70) 340-3016

Authorized officer

Fazio, Valentina

INTERNATIONAL SEARCH REPORT

Information on patent family members

International application No PCT/EP2014/052842

Patent document cited in search report	Publication date	Patent family member(s)	Publication date
US 2012075425 A1	29-03-2012	DE 102009001086 A1	02-09-2010
		EP 2398379 A1	28-12-2011
		JP 5368587 B2	18-12-2013
		JP 2012518445 A	16-08-2012
		US 2012075425 A1	29-03-2012
		WO 2010094805 A1	26-08-2010

WO 2010145669 A1	23-12-2010	AU 2010262191 A1	08-12-2011
		CA 2763826 A1	23-12-2010
		CN 102802520 A	28-11-2012
		EP 2442720 A1	25-04-2012
		JP 2012530267 A	29-11-2012
		US 2012092461 A1	19-04-2012
		WO 2010145669 A1	23-12-2010

WO 2012083967 A1	28-06-2012	EP 2654607 A1	30-10-2013
		US 2014022356 A1	23-01-2014
		WO 2012083967 A1	28-06-2012

FURTHER INFORMATION CONTINUED FROM PCT/ISA/ 210

This International Searching Authority found multiple (groups of) inventions in this international application, as follows:

1. claims: 1-18, 20-28

Three dimensional scanner and method of scanning of the surface geontry and surface color of an object. The surface geometry information and surface color information is derived by calculating for several 2D images a correlation measure between the portion of the 2D image captured by said block of image sensor pixels and a weight function, where the weight function is determined based on information of the configuration of the spatial pattern.

1.1. claims: 17, 18

Three dimensional scanner and method of scanning of the surface geontry and surface color of an object. The data processing system is configured for detecting saturated pixels in the captured 2D images.

2. claim: 19

Three dimensional scanner and method of scanning of the surface geontry and surface color of an object. The data processing system is configured for comparing the derived surface color information of sections of the captured 2D images and/or of the generated sub-scans of the object with predetermined color ranges for teeth and for oral tissue, and for suppressing the red component of the derived surface color information or sub-scan color for sections where the color is not in one of the two predetermined color ranges.

(12) INTERNATIONAL APPLICATION PUBLISHED UNDER THE PATENT COOPERATION TREATY (PCT)

(19) World Intellectual Property Organization
International Bureau



(43) International Publication Date
23 December 2010 (23.12.2010)

(10) International Publication Number
WO 2010/145669 A1

- (51) **International Patent Classification:**
A61B 5/107 (2006.01)
- (21) **International Application Number:**
PCT/DK2010/050148
- (22) **International Filing Date:**
17 June 2010 (17.06.2010)
- (25) **Filing Language:** English
- (26) **Publication Language:** English
- (30) **Priority Data:**
61/187,744 17 June 2009 (17.06.2009) US
61/231,118 4 August 2009 (04.08.2009) US
- (71) **Applicant (for all designated States except US):**
3SHAPE A/S [DK/DK]; Holmens Kanal 7, 4. sal,
DK-1060 Copenhagen K (DK).
- (72) **Inventors; and**
- (75) **Inventors/Applicants (for US only):** FISKER, Rune [DK/DK]; Kaplevej 87, DK-2830 Virum (DK). ÖJELUND, Henrik [SE/DK]; Kulsvierparken 55, DK-2800 Lyngby (DK). KJÆR, Rasmus [DK/DK]; Nørre Søgade 21, 1, DK-1370 Copenhagen K (DK). VAN DER POEL, Mike [NL/DK]; Rævebakkevej 35B, DK-2610 Rødovre (DK). QAZI, Arish A [PK/CA]; 215-1369 Bloor Street West, M6P 4J4, Toronto (CA). HOLLENBECK, Karl-Josef [DE/DK]; Ribegade 12, 3.th, DK-2100 Copenhagen Ø (DK).
- (74) **Agent:** HØIBERG A/S; St. Kongensgade 59 A, DK-1264 Copenhagen K (DK).
- (81) **Designated States (unless otherwise indicated, for every kind of national protection available):** AE, AG, AL, AM, AO, AT, AU, AZ, BA, BB, BG, BH, BR, BW, BY, BZ, CA, CH, CL, CN, CO, CR, CU, CZ, DE, DK, DM, DO, DZ, EC, EE, EG, ES, FI, GB, GD, GE, GH, GM, GT, HN, HR, HU, ID, IL, IN, IS, JP, KE, KG, KM, KN, KP, KR, KZ, LA, LC, LK, LR, LS, LT, LU, LY, MA, MD, ME, MG, MK, MN, MW, MX, MY, MZ, NA, NG, NI, NO, NZ, OM, PE, PG, PH, PL, PT, RO, RS, RU, SC, SD, SE, SG, SK, SL, SM, ST, SV, SY, TH, TJ, TM, TN, TR, TT, TZ, UA, UG, US, UZ, VC, VN, ZA, ZM, ZW.
- (84) **Designated States (unless otherwise indicated, for every kind of regional protection available):** ARIPO (BW, GH, GM, KE, LR, LS, MW, MZ, NA, SD, SL, SZ, TZ, UG, ZM, ZW), Eurasian (AM, AZ, BY, KG, KZ, MD, RU, TJ, TM), European (AL, AT, BE, BG, CH, CY, CZ, DE, DK, EE, ES, FI, FR, GB, GR, HR, HU, IE, IS, IT, LT, LU, LV, MC, MK, MT, NL, NO, PL, PT, RO, SE, SI, SK, SM, TR), OAPI (BF, BJ, CF, CG, CI, CM, GA, GN, GQ, GW, ML, MR, NE, SN, TD, TG).

Declarations under Rule 4.17:

— of inventorship (Rule 4.17(iv))

Published:

— with international search report (Art. 21(3))



WO 2010/145669 A1

(54) **Title:** FOCUS SCANNING APPARATUS

(57) **Abstract:** Disclosed is a handheld scanner for obtaining and/or measuring the 3D geometry of at least a part of the surface of an object using confocal pattern projection techniques. Specific embodiments are given for intraoral scanning and scanning of the interior part of a human ear.

Focus scanning apparatus

5 The present invention relates to an apparatus and a method for optical 3D scanning of surfaces. The principle of the apparatus and method according to the invention may be applied in various contexts. One specific embodiment of the invention is particularly suited for intraoral scanning, i.e. direct scanning of teeth and surrounding soft-tissue in the oral cavity. Other dental related embodiments of the invention are suited for scanning dental impressions, gypsum models, wax bites, dental prosthetics and abutments. Another embodiment of the invention is suited for scanning of the interior and exterior part of a human ear or ear channel impressions. The invention may find use within scanning of the 3D structure of skin in dermatological or cosmetic /
10 cosmetological applications, scanning of jewelry or wax models of whole jewelry or part of jewelry, scanning of industrial parts and even time resolved 3D scanning, such as time resolved 3D scanning of moving industrial parts.

15

Background of the invention

20 The invention relates to three dimensional (3D) scanning of the surface geometry of objects. Scanning an object surface in 3 dimensions is a well known field of study and the methods for scanning can be divided into contact and non-contact methods. An example of contact measurements methods are Coordinate Measurement Machines (CMM), which measures by letting a tactile probe trace the surface. The advantages include great precision, but the process is slow and a CMM is large and expensive. Non-contact measurement methods include x-ray and optical probes.

25

Confocal microscopy is an optical imaging technique used to increase micrograph contrast and/or to reconstruct three-dimensional images by using a spatial pinhole to eliminate out-of-focus light or flare in specimens that are thicker than the focal plane.

30 A confocal microscope uses point illumination and a pinhole in an optically conjugate plane in front of the detector to eliminate out-of-focus information. Only the light within the focal plane can be detected. As only one point is illuminated at a time in confocal microscopy, 2D imaging requires raster scanning and 3D imaging requires raster scanning in a range of focus planes.

35

In WO 00/08415 the principle of confocal microscopy is applied by illuminating the surface with a plurality of illuminated spots. By varying the focal plane in-focus spot-specific positions of the surface can be determined. However, determination of the surface structure is limited to the parts of the surface that are illuminated by a spot.

5

WO 2003/060587 relates to optically sectioning of a specimen in microscopy wherein the specimen is illuminated with an illumination pattern. Focus positions of the image plane are determined by characterizing an oscillatory component of the pattern.

However, the focal plane can only be adjusted by moving the specimen and the optical system relative to each other, i.e. closer to or further away from each other. Thus, controlled variation of the focal plane requires a controlled spatial relation between the specimen and the optical system, which is fulfilled in a microscope. However, such a controlled spatial relation is not applicable to e.g. a hand held scanner.

15 US2007/0109559 A1 describes a focus scanner where distances are found from the focus lens positions at which maximum reflective intensity of light beams incident on the object being scanned is observed. In contrast to the invention disclosed here, this prior art exploits no pre-determined measure of the illumination pattern and exploits no contrast detection, and therefore, the signal-to-noise ratio is sub-optimal.

20

In WO 2008/125605, means for generating a time-variant pattern composed of alternating split images are described. This document describes a scanning method to obtain an optical section of a scan object by means of two different illumination profiles, e.g. two patterns of opposite phases. These two images are used to extract the optical section, and the method is limited to acquisition of images from only two different illumination profiles. Furthermore, the method relies on a predetermined calibration that determines the phase offset between the two illumination profiles.

25

Summary of the invention

30

Thus, an object of the invention is to provide a scanner which may be integrated in a manageable housing, such as a handheld housing. Further objects of the invention are: discriminate out-of-focus information and provide a fast scanning time.

This is achieved by a method and a scanner for obtaining and/or measuring the 3D geometry of at least a part of the surface of an object, said scanner comprising:

- 5 - at least one camera accommodating an array of sensor elements,
- means for generating a probe light incorporating a spatial pattern,
- 5 - means for transmitting the probe light towards the object thereby illuminating at least a part of the object with said pattern in one or more configurations,
- means for transmitting at least a part of the light returned from the object to the camera,
- 10 - means for varying the position of the focus plane of the pattern on the object while maintaining a fixed spatial relation of the scanner and the object,
- means for obtaining at least one image from said array of sensor elements,
- 15 - means for evaluating a correlation measure at each focus plane position between at least one image pixel and a weight function, where the weight function is determined based on information of the configuration of the spatial pattern;
- data processing means for:
 - 20 a) determining by analysis of the correlation measure the in-focus position(s) of:
 - each of a plurality of image pixels for a range of focus plane positions, or
 - each of a plurality of groups of image pixels for a range of
 - 25 focus plane positions, and
 - b) transforming in-focus data into 3D real world coordinates.

The method and apparatus described in this invention is for providing a 3D surface registration of objects using light as a non-contact probing agent. The light is provided
30 in the form of an illumination pattern to provide a light oscillation on the object. The variation / oscillation in the pattern may be spatial, e.g. a static checkerboard pattern, and/or it may be time varying, for example by moving a pattern across the object being scanned. The invention provides for a variation of the focus plane of the pattern over a
35 range of focus plane positions while maintaining a fixed spatial relation of the scanner

and the object. It does not mean that the scan must be provided with a fixed spatial relation of the scanner and the object, but merely that the focus plane can be varied (scanned) with a fixed spatial relation of the scanner and the object. This provides for a hand held scanner solution based on the present invention.

5

In some embodiments the signals from the array of sensor elements are light intensity.

One embodiment of the invention comprises a first optical system, such as an arrangement of lenses, for transmitting the probe light towards the object and a second
10 optical system for imaging light returned from the object to the camera. In the preferred embodiment of the invention only one optical system images the pattern onto the object and images the object, or at least a part of the object, onto the camera, preferably along the same optical axis, however along opposite optical paths.

15 In the preferred embodiment of the invention an optical system provides an imaging of the pattern onto the object being probed and from the object being probed to the camera. Preferably, the focus plane is adjusted in such a way that the image of the pattern on the probed object is shifted along the optical axis, preferably in equal steps from one end of the scanning region to the other. The probe light incorporating the
20 pattern provides a pattern of light and darkness on the object. Specifically, when the pattern is varied in time for a fixed focus plane then the in-focus regions on the object will display an oscillating pattern of light and darkness. The out-of-focus regions will display smaller or no contrast in the light oscillations.

25 Generally we consider the case where the light incident on the object is reflected diffusively and/or specularly from the object's surface. But it is understood that the scanning apparatus and method are not limited to this situation. They are also applicable to e.g. the situation where the incident light penetrates the surface and is reflected and/or scattered and/or gives rise to fluorescence and/or phosphorescence in
30 the object. Inner surfaces in a sufficiently translucent object may also be illuminated by the illumination pattern and be imaged onto the camera. In this case a volumetric scanning is possible. Some planktic organisms are examples of such objects.

35 When a time varying pattern is applied a single sub-scan can be obtained by collecting a number of 2D images at different positions of the focus plane and at different

instances of the pattern. As the focus plane coincides with the scan surface at a single pixel position, the pattern will be projected onto the surface point in-focus and with high contrast, thereby giving rise to a large variation, or amplitude, of the pixel value over time. For each pixel it is thus possible to identify individual settings of the focusing
5 plane for which each pixel will be in focus. By using knowledge of the optical system used, it is possible to transform the contrast information vs. position of the focus plane into 3D surface information, on an individual pixel basis.

Thus, in one embodiment of the invention the focus position is calculated by
10 determining the light oscillation amplitude for each of a plurality of sensor elements for a range of focus planes.

For a static pattern a single sub-scan can be obtained by collecting a number of 2D images at different positions of the focus plane. As the focus plane coincides with the
15 scan surface, the pattern will be projected onto the surface point in-focus and with high contrast. The high contrast gives rise to a large spatial variation of the static pattern on the surface of the object, thereby providing a large variation, or amplitude, of the pixel values over a group of adjacent pixels. For each group of pixels it is thus possible to identify individual settings of the focusing plane for which each group of pixels will be in
20 focus. By using knowledge of the optical system used, it is possible to transform the contrast information vs. position of the focus plane into 3D surface information, on an individual pixel group basis.

Thus, in one embodiment of the invention the focus position is calculated by
25 determining the light oscillation amplitude for each of a plurality of groups of the sensor elements for a range of focus planes.

The 2D to 3D conversion of the image data can be performed in a number of ways known in the art. I.e. the 3D surface structure of the probed object can be determined
30 by finding the plane corresponding to the maximum light oscillation amplitude for each sensor element, or for each group of sensor elements, in the camera's sensor array when recording the light amplitude for a range of different focus planes. Preferably, the focus plane is adjusted in equal steps from one end of the scanning region to the other. Preferably the focus plane can be moved in a range large enough to at least coincide
35 with the surface of the object being scanned.

The present invention distinguishes itself from WO 2008/125605, because in the embodiments of the present invention that use a time-variant pattern, input images are not limited to two illumination profiles and can be obtained from any illumination profile of the pattern. This is because the orientation of the reference image does not rely
5 entirely on a predetermined calibration, but rather on the specific time of the input image acquisition.

Thus WO 2008/125605 applies specifically exactly two patterns, which are realized physically by a chrome-on-glass mask as illuminated from either side, the reverse side
10 being reflective. WO 2008/125605 thus has the advantage of using no moving parts, but the disadvantage of a comparatively poorer signal-to-noise ratio. In the present invention there is the possibility of using any number of pattern configurations, which makes computation of the light oscillation amplitude or the correlation measure more precise.

15

Definitions

Pattern: A light signal comprising an embedded spatial structure in the lateral plane.
20 May also be termed "illumination pattern".

Time varying pattern: A pattern that varies in time, i.e. the embedded spatial structure varies in time. May also be termed "time varying illumination pattern". In the following also termed "fringes".

25

Static pattern: A pattern that does not vary in time, e.g. a static checkerboard pattern or a static line pattern.

Pattern configuration: The state of the pattern. Knowledge of the pattern
30 configuration at a certain time amounts to knowing the spatial structure of the illumination at that time. For a periodic pattern the pattern configuration will include information of the pattern phase. If a surface element of the object being scanned is imaged onto the camera then knowledge of the pattern configuration amounts to knowledge of what part of the pattern is illuminating the surface element.

35

Focus plane: A surface where light rays emitted from the pattern converge to form an image on the object being scanned. The focus plane does not need to be flat. It may be a curved surface.

5 **Optical system:** An arrangement of optical components, e.g. lenses, that transmit, collimate and/or images light, e.g. transmitting probe light towards the object, imaging the pattern on and/or in the object, and imaging the object, or at least a part of the object, on the camera.

10 **Optical axis:** An axis defined by the propagation of a light beam. An optical axis is preferably a straight line. In the preferred embodiment of the invention the optical axis is defined by the configuration of a plurality of optical components, e.g. the configuration of lenses in the optical system. There may be more than one optical axis, if for example one optical system transmits probe light to the object and another optical
15 system images the object on the camera. But preferably the optical axis is defined by the propagation of the light in the optical system transmitting the pattern onto the object and imaging the object onto the camera. The optical axis will often coincide with the longitudinal axis of the scanner.

20 **Optical path:** The path defined by the propagation of the light from the light source to the camera. Thus, a part of the optical path preferably coincides with the optical axis. Whereas the optical axis is preferably a straight line, the optical path may be a non-straight line, for example when the light is reflected, scattered, bent, divided and/or the like provided e.g. by means of beam splitters, mirrors, optical fibers and the like.

25 **Telecentric system:** An optical system that provides imaging in such a way that the chief rays are parallel to the optical axis of said optical system. In a telecentric system out-of-focus points have substantially same magnification as in-focus points. This may provide an advantage in the data processing. A perfectly telecentric optical system is
30 difficult to achieve, however an optical system which is substantially telecentric or near telecentric may be provided by careful optical design. Thus, when referring to a telecentric optical system it is to be understood that it may be only near telecentric.

35 **Scan length:** A lateral dimension of the field of view. If the probe tip (i.e. scan head) comprises folding optics to direct the probe light in a direction different such as

perpendicular to the optical axis then the scan length is the lateral dimension parallel to the optical axis.

5 **Scan object:** The object to be scanned and on which surface the scanner provides information. "The scan object" may just be termed "the object".

10 **Camera:** Imaging sensor comprising a plurality of sensors that respond to light input onto the imaging sensor. The sensors are preferably ordered in a 2D array in rows and columns.

15 **Input signal:** Light input signal or sensor input signal from the sensors in the camera. This can be integrated intensity of light incident on the sensor during the exposure time or integration of the sensor. In general, it translates to a pixel value within an image. May also be termed "sensor signal".

20 **Reference signal:** A signal derived from the pattern. A reference signal may also be denoted a weight function or weight vector or reference vector.

25 **Correlation measure:** A measure of the degree of correlation between a reference and input signal. Preferably the correlation measure is defined such that if the reference and input signal are linearly related to each other then the correlation measure obtains a larger magnitude than if they are not. In some cases the correlation measure is a light oscillation amplitude.

30 **Image:** An image can be viewed as a 2D array of values (when obtained with a digital camera) or in optics, an image indicates that there exists a relation between an imaged surface and an image surface where light rays emerging from one point on said imaged surface substantially converge on one point on said image surface.

35 **Intensity:** In optics, intensity is a measure of light power per unit area. In image recording with a camera comprising a plurality of individual sensing elements, intensity may be used to term the recorded light signal on the individual sensing elements. In this case intensity reflects a time integration of light power per unit area on the sensing element over the exposure time involved in the image recording.

Mathematical notation

	A	A correlation measure between the weight function and the recorded light signal. This can be a light oscillation amplitude.
5	I	Light input signal or sensor input signal. This can be integrated intensity of light incident on the sensor during the exposure time or integration of the sensor. In general, it translates to a pixel value within an image.
	f	Reference signal. May also be called weight value.
	n	The number of measurements with a camera sensor and/or several camera sensors that are used to compute a correlation measure.
10	H	Image height in number of pixels
	W	Image width in number of pixels

Symbols are also explained as needed in the text.

Detailed description of the invention

The scanner preferably comprises at least one beam splitter located in the optical path. For example, an image of the object may be formed in the camera by means of a beam
5 splitter. Exemplary uses of beam splitters are illustrated in the figures.

In a preferred embodiment of the invention light is transmitted in an optical system comprising a lens system. This lens system may transmit the pattern towards the object and images light reflected from the object to the camera.
10

In a telecentric optical system, out-of-focus points have the same magnification as in-focus points. Telecentric projection can therefore significantly ease the data mapping of acquired 2D images to 3D images. Thus, in a preferred embodiment of the invention the optical system is substantially telecentric in the space of the probed object. The
15 optical system may also be telecentric in the space of the pattern and camera.

Varying focus

A pivotal point of the invention is the variation, i.e. scanning, of the focal plane without moving the scanner in relation to the object being scanned. Preferably the focal plane
20 may be varied, such as continuously varied in a periodic fashion, while the pattern generation means, the camera, the optical system and the object being scanned is fixed in relation to each other. Further, the 3D surface acquisition time should be small enough to reduce the impact of relative movement between probe and teeth, e.g. reduce effect of shaking. In the preferred embodiment of the invention the focus plane
25 is varied by means of at least one focus element. Preferably the focus plane is periodically varied with a predefined frequency. Said frequency may be at least 1 Hz, such as at least 2 Hz, 3, 4, 5, 6, 7, 8, 9 or at least 10 Hz, such as at least 20, 40, 60, 80 or at least 100 Hz.

Preferably the focus element is part of the optical system. I.e. the focus element may
30 be a lens in a lens system. A preferred embodiment comprises means, such as a translation stage, for adjusting and controlling the position of the focus element. In that way the focus plane may be varied, for example by translating the focus element back and forth along the optical axis.

35

If a focus element is translated back and forth with a frequency of several Hz this may lead to instability of the scanner. A preferred embodiment of the invention thus comprises means for reducing and/or eliminating the vibration and/or shaking from the focus element adjustment system, thereby increasing the stability of the scanner. This may at least partly be provided by means for fixing and/or maintaining the centre of mass of the focus element adjustment system, such as a counter-weight to substantially counter-balance movement of the focus element; for example, by translating a counter-weight opposite to the movement of the focus element. Ease of operation may be achieved if the counter-weight and the focus element are connected and driven by the same translation means. This may however, only substantially reduce the vibration to the first order. If a counter-weight balanced device is rotated around the counter-weight balanced axis, there may be issues relating to the torque created by the counter-weights. A further embodiment of the invention thus comprises means for reducing and/or eliminating the first order, second order, third order and/or higher order vibration and/or shaking from the focus element adjustment system, thereby increasing the stability of the scanner.

In another embodiment of the invention more than one optical element is moved to shift the focal plane. In that embodiment it is desirable that these elements are moved together and that the elements are physically adjacent.

In the preferred embodiment of the invention the optical system is telecentric, or near telecentric, for all focus plane positions. Thus, even though one or more lenses in the optical system may be shifted back and forth to change the focus plane position, the telecentricity of the optical system is maintained.

The preferred embodiment of the invention comprises focus gearing. Focus gearing is the correlation between movement of the lens and movement of the focus plane position. E.g. a focus gearing of 2 means that a translation of the focus element of 1 mm corresponds to a translation of the focus plane position of 2 mm. Focus gearing can be provided by a suitable design of the optical system. The advantage of focus gearing is that a small movement of the focus element may correspond to a large variation of the focus plane position. In specific embodiments of the invention the focus gearing is between 0.1 and 100, such as between 0.1 and 1, such as between 1 and

10, such as between 2 and 8, such as between 3 and 6, such as least 10, such as at least 20.

5 In another embodiment of the invention the focus element is a liquid lens. A liquid lens can control the focus plane without use of any moving parts.

Camera

The camera may be a standard digital camera accommodating a standard CCD or CMOS chip with one A/D converter per line of sensor elements (pixels). However, to increase the frame rate the scanner according to the invention may comprise a high-speed camera accommodating multiple A/D converters per line of pixels, e.g. at least 2, 4, 8 or 16 A/D converters per line of pixels.

Pattern

15 Another central element of the invention is the probe light with an embedded pattern that is projected on to the object being scanned. The pattern may be static or time varying. The time varying pattern may provide a variation of light and darkness on and/or in the object. Specifically, when the pattern is varied in time for a fixed focus plane then the in-focus regions on the object will display an oscillating pattern of light and darkness. The out-of-focus regions will display smaller or no contrast in the light oscillations. The static pattern may provide a spatial variation of light and darkness on and/or in the object. Specifically, the in-focus regions will display an oscillating pattern of light and darkness in space. The out-of-focus regions will display smaller or no contrast in the spatial light oscillations.

25 Light may be provided from an external light source, however preferably the scanner comprises at least one light source and pattern generation means to produce the pattern. It is advantageous in terms of signal-to-noise ratio to design a light source such that the intensity in the non-masked parts of the pattern is as close to uniform in space as possible. In another embodiment the light source and the pattern generation means is integrated in a single component, such as a segmented LED. A segmented LED may provide a static pattern and/or it may provide a time varying pattern in itself by turning on and off the different segments in sequence. In one embodiment of the invention the time varying pattern is periodically varying in time. In another embodiment

30

of the invention the static pattern is periodically varying in space.

Light from the light source (external or internal) may be transmitted through the pattern generation means thereby generating the pattern. For example the pattern generation
5 means comprises at least one translucent and/or transparent pattern element. For generating a time varying pattern a wheel, with an opaque mask can be used. E.g. the mask comprises a plurality of radial spokes, preferably arranged in a symmetrical order. The scanner may also comprise means for rotating and/or translating the pattern
10 element. For generating a static pattern a glass plate with an opaque mask can be used. E.g. the mask comprises a line pattern or checkerboard pattern. In general said mask preferably possesses rotational and/or translational periodicity. The pattern element is located in the optical path. Thus, light from the light source may be transmitted through the pattern element, e.g. transmitted transversely through the
15 pattern element. The time varying pattern can then be generated by rotating and/or translating the pattern element. A pattern element generating a static pattern does not need to be moved during a scan.

Correlation

One object of the invention is to provide short scan time and real time processing, e.g.
20 to provide live feedback to a scanner operator to make a fast scan of an entire tooth arch. However, real time high resolution 3D scanning creates an enormous amount of data. Therefore data processing should be provided in the scanner housing, i.e. close to the optical components, to reduce data transfer rate to e.g. a cart, workstation or display. In order to speed up data processing time and in order to extract in-focus
25 information with an optimal signal-to-noise ratio various correlation techniques may be embedded / implemented. This may for example be implemented in the camera electronics to discriminate out-of-focus information. The pattern is applied to provide illumination with an embedded spatial structure on the object being scanned.

Determining in-focus information relates to calculating a correlation measure of this
30 spatially structured light signal (which we term input signal) with the variation of the pattern itself (which we term reference signal). In general the magnitude of the correlation measure is high if the input signal coincides with the reference signal. If the input signal displays little or no variation then the magnitude of the correlation measure is low. If the input signal displays a large spatial variation but this variation is different
35 than the variation in the reference signal then the magnitude of the correlation measure

is also low. In a further embodiment of the invention the scanner and/or the scanner head may be wireless, thereby simplifying handling and operation of the scanner and increasing accessibility under difficult scanning situations, e.g. intra-oral or in the ear scanning. However, wireless operation may further increase the need for local data
 5 processing to avoid wireless transmission of raw 3D data.

The reference signal is provided by the pattern generating means and may be periodic. The variation in the input signal may be periodic and it may be confined to one or a few periods. The reference signal may be determined independently of the input signal.
 10 Specifically in the case of a periodic variation, the phase between the oscillating input and reference signal may be known independently of the input signal. In the case of a periodic variation the correlation is typically related to the amplitude of the variation. If the phase between the oscillating input and reference signals is not known it is necessary to determine both cosine and sinusoidal part of the input signal before the
 15 input signal's amplitude of variation can be determined. This is not necessary when the phase is known.

One way to define the correlation measure mathematically with a discrete set of measurements is as a dot product computed from a signal vector, $\mathbf{I} = (I_1, \dots, I_n)$, with $n >$
 20 1 elements representing sensor signals and a reference vector, $\mathbf{f} = (f_1, \dots, f_n)$, of same length as said signal vector of reference weights. The correlation measure A is then given by

$$A = \mathbf{f} \cdot \mathbf{I} = \sum_{i=1}^n f_i I_i$$

The indices on the elements in the signal vector represent sensor signals that are recorded at different times and/or at different sensors. In the case of a continuous
 25 measurement the above expression is easily generalized to involve integration in place of the summation. In that case the integration parameter is time and/or one or more spatial coordinates.

A preferred embodiment is to remove the DC part of the correlation signal or correlation measure, i.e., when the reference vector elements sums to zero ($\sum_{i=1}^n f_i = 0$). The
 30 focus position can be found as an extremum of the correlation measure computed over all focus element positions. We note that in this case the correlation measure is proportional to the sample Pearson correlation coefficient between two variables. If the

DC part is not removed, there may exist a trend in DC signal over all focus element positions, and this trend can be dominating numerically. In this situation, the focus position may still be found by analysis of the correlation measure and/or one or more of its derivatives, preferably after trend removal.

5

Preferably, the global extremum should be found. However, artifacts such as dirt on the optical system can result in false global maxima. Therefore, it can be advisable to look for local extrema in some cases. If the object being scanned is sufficiently translucent it may be possible to identify interior surfaces or surface parts that are otherwise occluded. In such cases there may be several local extrema that corresponds to surfaces and it may be advantageous to process several or all extrema.

10

The correlation measure can typically be computed based on input signals that are available as digital images, i.e., images with a finite number of discrete pixels.

15

Therefore conveniently, the calculations for obtaining correlation measures can be performed for image pixels or groups thereof. Correlation measures can then be visualized in as pseudo-images.

The correlation measure applied in this invention is inspired by the principle of a lock-in amplifier, in which the input signal is multiplied by the reference signal and integrated over a specified time. In this invention, a reference signal is provided by the pattern.

20

Temporal correlation

Temporal correlation involves a time-varying pattern. The light signal in the individual light sensing elements in the camera is recorded several times while the pattern configuration is varied. The correlation measure is thus at least computed with sensor signals recorded at different times.

25

A principle to estimate light oscillation amplitude in a periodically varying light signal is taught in WO 98/45745 where the amplitude is calculated by first estimating a cosine and a sinusoidal part of the light intensity oscillation. However, from a statistical point of view this is not optimal because two parameters are estimated to be able to calculate the amplitude.

30

In this embodiment of the invention independent knowledge of the pattern configuration at each light signal recording allows for calculating the correlation measure at each light sensing element.

5 In some embodiments of the invention the scanner comprises means for obtaining knowledge of the pattern configuration. To provide such knowledge the scanner preferably further comprises means for registering and/or monitoring the time varying pattern.

10 Each individual light sensing element, i.e. sensor element, in the camera sees a variation in the light signal corresponding to the variation of the light illuminating the object.

One embodiment of the invention obtains the time variation of the pattern by translating
15 and/or rotating the pattern element. In this case the pattern configuration may be obtained by means of a position encoder on the pattern element combined with prior knowledge of the pattern geometry that gives rise to a pattern variation across individual sensing elements. Knowledge of the pattern configuration thus arises as a combination of knowledge of the pattern geometry that results in a variation across
20 different sensing elements and pattern registration and/or monitoring during the 3D scan. In case of a rotating wheel as the pattern element the angular position of the wheel may then be obtained by an encoder, e.g. mounted on the rim.

One embodiment of the invention involves a pattern that possesses translational and/or
25 rotational periodicity. In this embodiment there is a well-defined pattern oscillation period if the pattern is substantially translated and/or rotated at a constant speed.

One embodiment of the invention comprises means for sampling each of a plurality of the sensor elements a plurality of times during one pattern oscillation period, preferably
30 sampled an integer number of times, such as sampling 2, 3, 4, 5, 6, 7 or 8 times during each pattern oscillation period, thereby determining the light variation during a period.

The temporal correlation measure between the light variation and the pattern can be obtained by recording several images on the camera during one oscillation period (or at
35 least one oscillation period). The number of images recorded during one oscillation

period is denoted n . The registration of the pattern position for each individual image combined with the independently known pattern variation over all sensing element (i.e. obtaining knowledge of the pattern configuration) and the recorded images allows for an efficient extraction of the correlation measure in each individual sensing element in the camera. For a light sensing element with label j , the n recorded light signals of that element are denoted $I_{1,j}, \dots, I_{n,j}$. The correlation measure of that element, A_j , may be expressed as

$$A_j = \sum_{i=1}^n f_{i,j} I_{i,j}$$

Here the reference signal or weight function f is obtained from the knowledge of the pattern configuration. f has two indices i,j . The variation of f with the first index is derived from the knowledge of the pattern position during each image recording. The variation of f with the second index is derived from the knowledge of the pattern geometry which may be determined prior to the 3D scanning.

Preferably, but not necessarily, the reference signal f averages to zero over time, i.e. for all j we have

$$\sum_{i=1}^n f_{i,j} = 0$$

to suppress the DC part of the light variation or correlation measure. The focus position corresponding to the pattern being in focus on the object for a single sensor element in the camera will be given by an extremum value of the correlation measure of that sensor element when the focus position is varied over a range of values. The focus position may be varied in equal steps from one end of the scanning region to the other.

To obtain a sharp image of an object by means of a camera the object must be in focus and the optics of the camera and the object must be in a fixed spatial relationship during the exposure time of the image sensor of the camera. Applied to the present invention this should imply that the pattern and the focus should be varied in discrete steps to be able to fix the pattern and the focus for each image sampled in the camera, i.e. fixed during the exposure time of the sensor array. However, to increase the sensitivity of the image data the exposure time of the sensor array should be as high as the sensor frame rate permits. Thus, in the preferred embodiment of the invention images are recorded (sampled) in the camera while the pattern is continuously varying (e.g. by continuously rotating a pattern wheel) and the focus plane is continuously

5 moved. This implies that the individual images will be slightly blurred since they are the result of a time-integration of the image while the pattern is varying and the focus plane is moved. This is something that one could expect to lead to deterioration of the data quality, but in practice the advantage of concurrent variation of the pattern and the focus plane is bigger than the drawback.

10 In another embodiment of the invention images are recorded (sampled) in the camera while the pattern is fixed and the focus plane is continuously moved, i.e. no movement of the pattern. This could be the case when the light source is a segmented light source, such as a segment LED that flashes in an appropriate fashion. In this embodiment the knowledge of the pattern is obtained by a combination of prior knowledge of the geometry of the individual segments on the segmented LED give rise to a variation across light sensing elements and the applied current to different segments of the LED at each recording.

15 In yet another embodiment of the invention images are recorded (sampled) in the camera while the pattern is continuously varying and the focus plane is fixed.

20 In yet another embodiment of the invention images are recorded (sampled) in the camera while the pattern and the focus plane are fixed.

The temporal correlation principle may be applied in general within image analysis. Thus, a further embodiment of the invention relates to a method for calculating the amplitude of a light intensity oscillation in at least one (photoelectric) light sensitive element, said light intensity oscillation generated by a periodically varying illumination pattern and said amplitude calculated in at least one pattern oscillation period, said method comprising the steps of:

- providing the following a predetermined number of sampling times during a pattern oscillation period:
 - 30 ○ sampling the light sensitive element thereby providing the signal of said light sensitive element, and
 - providing an angular position and/or a phase of the periodically varying illumination pattern for said sampling, and
- calculating said amplitude(s) by integrating the products of a predetermined
35 periodic function and the signal of the corresponding light sensitive element over

said predetermined number of sampling times, wherein said periodic function is a function of the angular position and/or the phase of the periodically varying illumination pattern.

5 This may also be expressed as

$$A = \sum_i f(p_i) I_i$$

where A is the calculated amplitude or correlation measure, i is the index for each sampling, f is the periodic function, p_i is the angular position / phase of the illumination pattern for sampling i and I_i is the signal of the light sensitive element for sampling i .

10 Preferably the periodic function averages to zero over a pattern oscillation period, i.e.

$$\sum_i f(p_i) = 0.$$

To generalize the principle to a plurality of light sensitive elements, for example in a sensor array, the angular position / phase of the illumination pattern for a specific light sensitive element may consist of an angular position / phase associated with the illumination pattern plus a constant offset associated with the specific light sensitive element. Thereby the correlation measure or amplitude of the light oscillation in light sensitive element j may be expressed as

15

$$A_j = \sum_i f(\theta_j + p_i) I_{i,j},$$

20 where θ_j is the constant offset for light sensitive element j .

A periodically varying illumination pattern may be generated by a rotating wheel with an opaque mask comprising a plurality of radial spokes arranged in a symmetrical order. The angular position of the wheel will thereby correspond to the angular position of the pattern and this angular position may be obtained by an encoder mounted on the rim of the wheel. The pattern variation across different sensor elements for different position of the pattern may be determined prior to the 3D scanning in a calibration routine. A combination of knowledge of this pattern variation and the pattern position constitutes knowledge of the pattern configuration. A period of this pattern may for example be the time between two spokes and the amplitude of a single or a plurality of light sensitive elements of this period may be calculated by sampling e.g. four times in this period.

25

30

A periodically varying illumination pattern may be generated by a Ronchi ruling moving orthogonal to the lines and the position is measured by an encoder. This position corresponds to the angular position of the generated pattern. Alternatively, a checkerboard pattern could be used.

5

A periodically varying illumination pattern may be generated by a one-dimensional array of LEDs that can be controlled line wise.

A varying illumination pattern may be generated by a LCD or DLP based projector.

10 *Optical correlation*

The abovementioned correlation principle (temporal correlation) requires some sort of registering of the time varying pattern, e.g. knowledge of the pattern configuration at each light level recording in the camera. However, a correlation principle without this registering may be provided in another embodiment of the invention. This principle is

15

termed "optical correlation".

In this embodiment of the invention an image of the pattern itself and an image of at least a part of the object being scanned with the pattern projected onto it is combined on the camera. I.e. the image on the camera is a superposition of the pattern itself and

20

the object being probed with the pattern projected onto it. A different way of expressing this is that the image on the camera substantially is a multiplication of an image of the pattern projected onto the object with the pattern itself.

This may be provided in the following way. In a further embodiment of the invention the

25

pattern generation means comprises a transparent pattern element with an opaque mask. The probe light is transmitted through the pattern element, preferably transmitted transversely through the pattern element. The light returned from the object being scanned is retransmitted the opposite way through said pattern element and imaged onto the camera. This is preferably done in a way where the image of the pattern

30

illuminating the object and the image of the pattern itself are coinciding when both are imaged onto the camera. One particular example of a pattern is a rotating wheel with an opaque mask comprising a plurality of radial spokes arranged in a symmetrical order such that the pattern possesses rotational periodicity. In this embodiment there is a well-defined pattern oscillation period if the pattern is substantially rotated at a

35

constant speed. We define the oscillation period as $2\pi/\omega$.

We note that in the described embodiment of the invention the illumination pattern is a pattern of light and darkness. A light sensing element in the camera with a signal proportional to the integrated light intensity during the camera integration time δt with label j , I_j is given by

$$I_j = K \int_t^{t+\delta t} T_j(t') S_j(t') dt'$$

Here K is the proportionality constant of the sensor signal, t is the start of the camera integration time, T_j is the time-varying transmission of the part of the rotating pattern element imaged onto the j 'th light sensing element, and S_j is the time-varying light intensity of light returned from the scanned object and imaged onto the j 'th light sensing element. In the described embodiment T_j is the the step function substantially defined by $T_j(t) = 0$ for $\sin(\omega t + \phi_j) > 0$ and $T_j(t) = 1$ elsewhere. ϕ_j is a phase dependent on the position of the j 'th imaging sensor.

The signal on the light sensing element is a correlation measure of the pattern and the light returned from the object being scanned. The time-varying transmission takes the role of the reference signal and the time-varying light intensity of light returned from the scanned object takes the role of the input signal. The advantage of this embodiment of the invention is that a normal CCD or CMOS camera with intensity sensing elements may be used to record the correlation measure directly since this appears as an intensity on the sensing elements. Another way of expressing this is that the computation of the correlation measure takes place in the analog, optical domain instead of in an electronic domain such as an FPGA or a PC.

The focus position corresponding to the pattern being in focus on the object being scanned for a single sensor element in the camera will then be given by the maximum value of the correlation measure recorded with that sensor element when the focus position is varied over a range of values. The focus position may be varied in equal steps from one end of the scanning region to the other. One embodiment of the invention comprises means for recording and/or integrating and/or monitoring and/or storing each of a plurality of the sensor elements over a range of focus plane positions.

Preferably, the global maximum should be found. However, artifacts such as dirt on the optical system can result in false global maxima. Therefore, it can be advisable to look for local maxima in some cases.

5 Since the reference signal does not average to zero the correlation measure has a DC component. Since the DC part is not removed, there may exist a trend in DC signal over all focus element positions, and this trend can be dominating numerically. In this situation, the focus position may still be found by analysis of the correlation measure and/or one or more of its derivatives.

10

In a further embodiment of the invention the camera integration time is an integer number M of the pattern oscillation period, i.e. $\delta t = 2\pi M / \omega$. One advantage of this embodiment is that the magnitude of the correlation measure can be measured with a better signal-to-noise ratio in the presence of noise than if the camera integration time is not an integer number of the pattern oscillation period.

15

In another further embodiment of the invention the camera integration time is much longer than pattern oscillation period, i.e. $\delta t \gg 2\pi M / \omega$. Many times the pattern oscillation time would here mean e.g. camera integration time at least 10 times the oscillation time or more preferably such as at least 100 or 1000 times the oscillation time. One advantage of this embodiment is that there is no need for synchronization of camera integration time and pattern oscillation time since for very long camera integration times compared to the pattern oscillation time the recorded correlation measure is substantially independent of accurate synchronization.

20

25

Equivalent to the temporal correlation principle the optical correlation principle may be applied in general within image analysis. Thus, a further embodiment of the invention relates to a method for calculating the amplitude of a light intensity oscillation in at least one (photoelectric) light sensitive element, said light intensity oscillation generated by a superposition of a varying illumination pattern with itself, and said amplitude calculated by time integrating the signal from said at least one light sensitive element over a plurality of pattern oscillation periods.

30

Spatial correlation

The above mentioned correlation principles (temporal correlation and optical correlation) require the pattern to be varying in time. If the optical system and camera provides a lateral resolution which is at least two times what is needed for the scan of the object then it is possible to scan with a static pattern, i.e. a pattern which is not
5 changing in time. This principle is termed "spatial correlation". The correlation measure is thus at least computed with sensor signals recorded at different sensor sites.

The lateral resolution of an optical system is to be understood as the ability of optical elements in the optical system, e.g. a lens system, to image spatial frequencies on the
10 object being scanned up to a certain point. Modulation transfer curves of the optical system are typically used to describe imaging of spatial frequencies in an optical system. One could e.g. define the resolution of the optical system as the spatial frequency on the object being scanned where the modulation transfer curve has decreased to e.g. 50%. The resolution of the camera is a combined effect of the
15 spacing of the individual camera sensor elements and the resolution of the optical system.

In the spatial correlation the correlation measure refers to a correlation between input signal and reference signal occurring in space rather than in time. Thus, in one
20 embodiment of the invention the resolution of the measured 3D geometry is equal to the resolution of the camera. However, for the spatial correlation the resolution of the measured 3D geometry is lower than the resolution of the camera, such as at least 2 times lower, such as at least 3 times lower, such as at least 4 times lower, such as
25 least 5 times lower, such as at least 10 times lower. The sensor element array is preferably divided into groups of sensor elements, preferably rectangular groups, such as square groups of sensor elements, preferably adjacent sensor elements. The resolution of the scan, i.e. the measured 3D geometry, will then be determined by the size of these groups of sensor elements. The oscillation in the light signal is provided within these groups of sensor elements, and the amplitude of the light oscillation may
30 then be obtained by analyzing the groups of sensor elements. The division of the sensor element array into groups is preferably provided in the data processing stage, i.e. the division is not a physical division thereby possibly requiring a specially adapted sensor array. Thus, the division into groups is "virtual" even though the single pixel in a
35 group is an actual physical pixel.

In one embodiment of the invention the pattern possesses translational periodicity along at least one spatial coordinate. In a further embodiment of the invention the spatially periodic pattern is aligned with the rows and/or the columns of the array of sensor elements. For example in the case of a static line pattern the rows or columns of the pixels in the camera may be parallel with the lines of the pattern. Or in the case of a static checkerboard pattern the row and columns of the checkerboard may be aligned with the rows and columns, respectively, of the pixels in the camera. By aligning is meant that the image of the pattern onto the camera is aligned with the "pattern" of the sensor element in the sensor array of the camera. Thus, a certain physical location and orientation of the pattern generation means and the camera requires a certain configuration of the optical components of the scanner for the pattern to be aligned with sensor array of the camera.

In a further embodiment of the invention at least one spatial period of the pattern corresponds to a group of sensor elements. In a further embodiment of the invention all groups of sensor elements contain the same number of elements and have the same shape. E.g. when the period of a checkerboard pattern corresponds to a square group of e.g. 2x2, 3x3, 4x4, 5x5, 6x6, 7x7, 8x8, 9x9, 10x10 or more pixels on the camera.

In yet another embodiment one or more edges of the pattern is aligned with and/or coincide with one or more edges of the array of sensor elements. For example a checkerboard pattern may be aligned with the camera pixels in such a way that the edges of the image of the checkerboard pattern onto the camera coincide with the edges of the pixels.

In spatial correlation independent knowledge of the pattern configuration allows for calculating the correlation measure at each group of light sensing. For a spatially periodic illumination this correlation measure can be computed without having to estimate the cosine and sinusoidal part of the light intensity oscillation. The knowledge of the pattern configuration may be obtained prior to the 3D scanning.

In a further embodiment of the invention the correlation measure, A_j , within a group of sensor elements with label j is determined by means of the following formula:

$$A_j = \sum_{i=1}^n f_{i,j} I_{i,j}$$

Where n is the number of sensor elements in a group of sensors, $\mathbf{f}_j = (f_{1,j}, \dots, f_{n,j})$ is the reference signal vector obtained from knowledge of the pattern configuration, and $\mathbf{I}_j = (I_{1,j}, \dots, I_{n,j})$ is input signal vector. For the case of sensors grouped in square regions with N sensors as square length then $n = N^2$.

5

Preferably, but not necessarily, the elements of the reference signal vector averages to zero over space, i.e. for all j we have

$$\sum_{i=1}^n f_{i,j} = 0$$

10

to suppress the DC part of the correlation measure. The focus position corresponding to the pattern being in focus on the object for a single group of sensor elements in the camera will be given by an extremum value of the correlation measure of that sensor element group when the focus position is varied over a range of values. The focus position may be varied in equal steps from one end of the scanning region to the other.

15

In the case of a static checkerboard pattern with edges aligned with the camera pixels and with the pixel groups having an even number of pixels such as 2x2, 4x4, 6x6, 8x8, 10x10, a natural choice of the reference vector \mathbf{f} would be for its elements to assume the value 1 for the pixels that image a bright square of the checkerboard and -1 for the pixels that image a dark square of the checkerboard.

20

Equivalent to the other correlation principles the spatial correlation principle may be applied in general within image analysis. In particular in a situation where the resolution of the camera is higher than what is necessary in the final image. Thus, a further embodiment of the invention relates to a method for calculating the amplitude(s) of a light intensity oscillation in at least one group of light sensitive elements, said light intensity oscillation generated by a spatially varying static illumination pattern, said method comprising the steps of:

25

- providing the signal from each light sensitive element in said group of light sensitive elements, and
- calculating said amplitude(s) by integrating the products of a predetermined function and the signal from the corresponding light sensitive element over said group of light sensitive elements, wherein said predetermined function is a function reflecting the illumination pattern.

30

To generalize the principle to a plurality of light sensitive elements, for example in a sensor array, the correlation measure or amplitude of the light oscillation in group j may be expressed as

$$A_j = \sum_{i=1}^n f(i, j) I_{i,j} ,$$

- 5 where n is the number of sensor elements in group j , $I_{i,j}$ is the signal from the i 'th sensor element in group j and $f(i,j)$ is a predetermined function reflecting the pattern.

Compared to temporal correlation, spatial correlation has the advantage that no moving pattern is required. This implies that knowledge of the pattern configuration may be
10 obtained prior to the 3D scanning. Conversely, the advantage of temporal correlation is its higher resolution, as no pixel grouping is required.

All correlation principles, when embodied with an image sensor that allows very high frame rates, enable 3D scanning of objects in motion with little motion blur. It also
15 becomes possible to trace moving objects over time ("4D scanning"), with useful applications for example in machine vision and dynamic deformation measurement. Very high frame rates in this context are at least 500, but preferably at least 2000 frames per second.

20 *Transforming correlation measure extrema to 3D world coordinates*

Relating identified focus position(s) for camera sensor or camera sensor groups to 3D world coordinates may be done by ray tracing through the optical system. Before such ray tracing can be performed the parameters of the optical system need to be known.
25 One embodiment of the invention comprises a calibration step to obtain such knowledge. A further embodiment of the invention comprises a calibration step in which images of an object of known geometry are recorded for a plurality of focus positions. Such an object may be a planar checkerboard pattern. Then, the scanner can be calibrated by generating simulated ray traced images of the calibration object and then
30 adjusting optical system parameters as to minimize the difference between the simulated and recorded images.

In a further embodiment of the invention the calibration step requires recording of images for a plurality of focus positions for several different calibration objects and/or several different orientations and/or positions of one calibration object.

- 5 With knowledge of the parameters of the optical system, one can employ backward ray tracing technique to estimate the 2D -> 3D mapping. This requires that the scanner's optical system be known, preferably through calibration. The following steps can be performed:
- 10 1. From each pixel of the image (at the image sensor), trace a certain number of rays, starting from the image sensor and through the optical system (backward ray tracing).
 2. From the rays that emit, calculate the focus point, the point where all these rays substantially intersect. This point represents the 3D coordinate of where a 2D pixel will be in focus, i.e., in yield the global maximum of light oscillation amplitude.
 3. Generate a look up table for all the pixels with their corresponding 3D coordinates.
- 15 The above steps are repeated for a number of different focus lens positions covering the scanner's operation range.

Specular reflections

High spatial contrast of the in-focus pattern image on the object is often necessary to obtain a good signal to noise ratio of the correlation measure on the camera. This in turn may be necessary to obtain a good estimation of the focus position corresponding to an extremum in the correlation measure. This sufficient signal to noise ratio for successful scanning is often easily achieved in objects with a diffuse surface and negligible light penetration. For some objects, however, it is difficult to achieve high spatial contrast.

20

25

A difficult kind of object, for instance, is an object displaying multiple scattering of the incident light with a light diffusion length large compared to the smallest feature size of the spatial pattern imaged onto the object. A human tooth is an example of such an object. The human ear and ear canal are other examples. In case of intra oral scanning, the scanning should preferably be provided without spraying and/or drying the teeth to reduce the specular reflections and light penetration. Improved spatial contrast can be achieved by preferential imaging of the specular surface reflection from the object on the camera. Thus, one embodiment of the invention comprises means for preferential / selectively imaging of specular reflected light and/or diffusively

30

35

reflected light. This may be provided if the scanner further comprises means for polarizing the probe light, for example by means of at least one polarizing beam splitter. A polarizing beam splitter may for instance be provided for forming an image of the object in the camera. This may be utilized to extinguish specular reflections,
5 because if the incident light is linearly polarized a specular reflection from the object has the property that it preserves its polarization state

The scanner according to the invention may further comprise means for changing the polarization state of the probe light and/or the light reflected from the object. This can
10 be provided by means of a retardation plate, preferably located in the optical path. In one embodiment of the invention the retardation plate is a quarter wave retardation plate. A linearly polarized light wave is transformed into a circularly polarized light wave upon passage of a quarter wave plate with an orientation of 45 degrees of its fast axis to the linear polarization direction. This may be utilized to enhance specular reflections
15 because a specular reflection from the object has the property that it flips the helicity of a circularly polarized light wave, whereas light that is reflected by one or more scattering events becomes depolarized.

The field of view (scanning length)

20 In one embodiment of the invention the probe light is transmitted towards the object in a direction substantially parallel with the optical axis. However, for the scan head to be entered into a small space such as the oral cavity of a patient it is necessary that the tip of the scan head is sufficiently small. At the same time the light out of the scan head need to leave the scan head in a direction different from the optical axis. Thus, a further
25 embodiment of the invention comprises means for directing the probe light and/or imaging an object in a direction different from the optical axis. This may be provided by means of at least one folding element, preferably located along the optical axis, for directing the probe light and/or imaging an object in a direction different from the optical axis. The folding element could be a light reflecting element such as a mirror or a
30 prism. In one embodiment of the invention a 45 degree mirror is used as folding optics to direct the light path onto the object. Thereby the probe light is guided in a direction perpendicular to the optical axis. In this embodiment the height of the scan tip is at least as large as the scan length and preferably of approximately equal size.

One embodiment of the invention comprises at least two light sources, such as light sources with different wavelengths and/or different polarization. Preferably also control means for controlling said at least two light sources. Preferably this embodiment comprises means for combining and/or merging light from said at least two light sources. Preferably also means for separating light from said at least two light sources. If waveguide light sources are used they may be merged by waveguides. However, one or more diffusers may also be provided to merge light sources.

Separation and/or merging may be provided by at least one optical device which is partially light transmitting and partially light reflecting, said optical device preferably located along the optical axis, an optical device such as a coated mirror or coated plate. One embodiment comprises at least two of said optical devices, said optical devices preferably displaced along the optical axis. Preferably at least one of said optical devices transmits light at certain wavelengths and/or polarizations and reflects light at other wavelengths and/or polarizations.

One exemplary embodiment of the invention comprises at least a first and a second light source, said light sources having different wavelength and/or polarization, and wherein
a first optical device reflects light from said first light source in a direction different from the optical axis and transmits light from said second light source, and
a second optical device reflects light from said second light source in a direction different from the optical axis. Preferably said first and second optical devices reflect the probe light in parallel directions, preferably in a direction perpendicular to the optical axis, thereby imaging different parts of the object surface. Said different parts of the object surface may be at least partially overlapping.

Thus, for example light from a first and a second light source emitting light of different wavelengths (and/or polarizations) is merged together using a suitably coated plate that transmits the light from the first light source and reflects the light from the second light source. At the scan tip along the optical axis a first optical device (e.g. a suitably coated plate, dichroic filter) reflects the light from the first light source onto the object and transmits the light from the second light source to a second optical device (e.g. a mirror) at the end of the scan tip, i.e. further down the optical axis. During scanning the

focus position is moved such that the light from the first light source is used to project an image of the pattern to a position below the first optical device while second light source is switched off. The 3D surface of the object in the region below the first optical device is recorded. Then the first light source is switched off and the second light source is switched on and the focus position is moved such that the light from the second light source is used to project an image of the pattern to a position below the second optical device. The 3D surface of the object in the region below the second optical device is recorded. The region covered with the light from the two light sources respectively may partially overlap.

10

In another embodiment of the invention the probe light is directed in a direction different from the optical axis by means of a curved fold mirror. This embodiment may comprise one or more optical elements, such as lenses, with surfaces that may be aspherical to provide corrected optical imaging.

15

A further embodiment of the invention comprises of at least one translation stage for translating mirror(s) along the optical axis. This allows for a scan tip with a smaller height than the scan length. A large scan length can be achieved by combining several scans with the mirror(s) in different positions along the optical axis.

20

In another embodiment of the invention the probe light is directed in a direction different from the optical axis by means of at least one grating that provides anamorphic magnification so that the image of the pattern on the object being scanned is stretched.

25

The grating may be blazed. In this embodiment the light source needs to be monochromatic or semi-monochromatic.

The abovementioned embodiments suitable for increasing the scan length may comprise control means for providing a coordination of the light sources and the focus element.

30

Color scanning

One embodiment of the invention is only registering the surface topology (geometry) of the object being scanned. However, another embodiment of the invention is being adapted to obtain the color of the surface being scanned, i.e. capable of registering the

35

color of the individual surface elements of the object being scanned together with the surface topology of the object being scanned. To obtain color information the light source needs to be white or to comprise at least three monochromatic light sources with colors distributed across the visible part of the electromagnetic spectrum.

5

To provide color information the array of sensor elements may be a color image sensor. The image sensor may accommodate a Bayer color filter scheme. However, other color image sensor types may be provided, such as a Foveon type color image sensor, wherein the image sensor provides color registration in each sensor element.

10

One embodiment of the invention comprises means selecting one color of the probe light at a time, i.e. selectively switching between different colors of the probe light, thereby illuminating the object with different colors. If a white light source is used then some kind of color filtering must be provided. Preferably comprising a plurality of color filters, such as red, green and blue color filters, and means for inserting said color filters singly in front of the white light source, thereby selecting a color of the probe light.

15

In one embodiment of the invention color filters are integrated in the pattern generation means, i.e. the pattern generation means comprises color filters, such as translucent and/or transparent parts that are substantially monochromatically colored. For example a pattern element such as a rotating wheel with an opaque mask and where the translucent / transparent parts are color filters. For example one third of the wheel is red, one third is green and one third is blue.

20

Probe light of different colors may also be provided by at least three monochromatic light sources, such as lasers or LED's, said light sources having wavelengths distributed across the visible part of the wavelength spectrum. This will in general also require means for merging said light sources. For example suitable coated plates. In the case of waveguide light sources, the merging may be provided by a waveguide element.

25

To handle the different colors of the probe light the optical system is preferably substantially achromatic.

30

One embodiment of the invention comprises means for switching between at least two colors, preferably three colors, such as red, green and blue, of the probe light for a focal plane position. I.e. for a single focal plane position it is possible to switch between different colors of the probe light. For example by switching on and off different
5 monochromatic light sources (having one only light source turned on at a time) or by applying different color filters. Furthermore, the amplitude of the light signal of each of a plurality of the sensor elements may be determined for each color for each focal plane positions. I.e. for each focus position the color of the probe light may be switched. The embedded time varying pattern provides a single color oscillating light signal and the
10 amplitude of the signal in each sensor element may be determined for that color. Switching to the next color the amplitude may be determined again. When the amplitude has been determined for all colors the focus position is changed and the process is repeated. The color of the surface being scanned may then be obtained by combining and/or weighing the color information from a plurality of the sensor
15 elements. E.g. the color expressed as e.g. an RGB color coordinate of each surface element can be reconstructed by appropriate weighting of the amplitude signal for each color corresponding to the maximum amplitude. This technique may also be applied when a static pattern is provided where the color of at least a part of the pattern is varying in time.

20

To decrease the amount of data to be processed the color resolution of the imaging may be chosen to be less than the spatial resolution. The color information is then provided by data interpolation. Thus, in one embodiment of the invention the amplitude of the light signal of each of a plurality of the sensor elements is determined for each
25 color for selected full color focal plane positions, and the amplitude of the light signal of each of a plurality of the sensor elements is determined for one color for each focal plane position. Then the color of the surface being scanned may be obtained by interpolating the color information from full color focal plane positions. Thus, for example the amplitude is registered for all colors at an interval of N focus positions;
30 while one color is selected for determination of the amplitude at all focus positions. N is a number which could be e.g. 3, 5, or 10. This results in a color resolution which is less than the resolution of the surface topology. This technique may also be applied when a static pattern is provided where the color of at least a part of the pattern is varying in
time.

35

Another embodiment of the invention does not register full color information and employs only two light sources with different colors. An example of this is a dental scanner that uses red and blue light to distinguish hard (tooth) tissue from soft (gum) tissue.

5

Impression scanning

One embodiment of the invention is adapted to impression scanning, such as scanning of dental impressions and/or ear canal impressions.

10

Small cavity scanner

Specific applications of the scanner according to the invention relates to scanning of cavities, in particular body cavities. Scanning in cavities may relate to scanning of objects in the cavity, such as scanning of teeth in a mouth. However, scanning of e.g. the ear relate to scanning of the inner surface of the cavity itself. In general scanning of a cavity, especially a small cavity, requires some kind of probe for the scanner. Thus, in one embodiment of the invention the point of emission of probe light and the point of accumulation of reflected light is located on a probe, said probe being adapted to be entered into a cavity, such as a body cavity.

15

20 In another embodiment of the invention the probe is adapted to scan at least a part of the surface of a cavity, such as an ear canal. The ability to scan at least a part of the external part of the ear and/or the ear canal and make a virtual or real model of the ear is essential in the design of modern custom-fitted hearing aid (e.g. ear shell or mold). Today, scanning of ears is performed in a two-step process where a silicone
25 impression of the ear is taken first and the impression is subsequently scanned using an external scanner in a second step.

Thus, one embodiment of the invention comprises
30 a housing accommodating the camera, pattern generation means, focus varying means and data processing means, and
at least one probe accommodating a first optical system, preferably a substantially elongated probe.

35 Preferably, the point of emission of probe light and the point of accumulation of light returned from the scanned object is located on said probe. The optical system in the

probe is for transmitting the probe light from the housing toward the object and also for transmitting and/or imaging light returned from the object back towards the housing where the camera is located. Thus, the optical system in the probe may comprise a system of lenses. In one embodiment of the invention probe may comprise at least one
5 optical fibre and/or a fibre bundle for transmitting / transporting / guiding the probe light and/or the returned light from the object surface. In this case the optical fibre(s) may act as an optical relay system that merely transports light (i.e. probe light and returned light) inside the probe. In one embodiment of the invention the probe is endoscopic. The probe may be rigid or flexible. Use of optical fibre(s) in the probe may e.g. provide
10 a flexible probe with a small diameter.

In one embodiment of the invention the light is transmitted to the object and imaged by means of only the optical system in the probe, the first optical system. However, in a further embodiment of the invention the housing may further comprise a second optical
15 system.

In a further embodiment of the invention the probe is detachable from the housing. Then preferably a first point of emission of probe light and a first point of accumulation of returned light is located on the probe, and a second point of emission of probe light
20 and a second point of accumulation of returned light is located on the housing. This may require optical systems in both the housing and the probe. Thus, a scan may be obtained with the probe attached to the housing. However, a scan may also be obtained with the probe detached from the housing, i.e. the housing may be a standalone scanner in itself. For example the probe may be adapted to be inserted into
25 and scanning the inside of a cavity, whereas the housing may be adapted to scanning of exterior surfaces. The attachment of the probe may include mechanical and/or electrical transfer between the housing and the probe. For instance attaching the probe may provide an electrical signal to the control electronics in the housing that signals the current configuration of the device.

30 In one embodiment of the invention the probe light is directed toward the object in a direction substantially parallel with the optical axis and/or the longitudinal axis of the probe. In a further embodiment the probe comprises a posterior reflective element, such as a mirror, for directing the probe light in a direction different from the optical
35 axis, preferably in a direction perpendicular to the optical axis. Applying to the

abovementioned example with a stand-alone scanner housing with the probe detached, the probe light may exit the housing in a direction parallel with the optical axis of the optical system in the housing (i.e. the second optical system), whereas with the probe attached the probe light may be directed in a direction different than the optical axis of the optical system of the probe (i.e. the first optical system). Thereby the probe is better adapted to scanning a cavity.

In some embodiments of this invention, waste heat generated in the scanner is used to warm the probe such that no or less condensation occurs on the probe when the probe is inside the body cavity, e.g. the mouth. Waste heat can, e.g., be generated by the processing electronics, the light source, and/or the mechanism that moves the focus element.

In some embodiments of this invention, the scanner provides feedback to the user when the registration of subsequent scans to a larger model of the 3D surface fails. For example, the scanner could flash the light source.

Further, the probe may comprise means for rotating / spinning the reflective element, preferably around an axis substantially parallel with the optical axis and/or the longitudinal axis of the probe. Thereby the probe may be adapted to provide a scan 360° around the optical axis and/or the longitudinal axis of the probe, preferably without rotation of probe and/or scanner.

In a further embodiment of the invention a plurality of different probes matches the housing. Thereby different probes adapted to different environments, surfaces, cavities, etc. may be attached to the housing to account for different scanning situations. A specific example of this is when the scanner comprises a first probe being adapted to scan the interior part of a human ear and a second probe being adapted to scan the exterior part of said human ear. Instead of a second probe it may be the housing itself, i.e. with the probe detached, that is adapted to scan the exterior part of said human ear. I.e. the housing may be adapted to perform a 3D surface scan. In other words: the housing with the probe attached may be adapted to scan the interior part of a human ear and the housing with the probe detached may be adapted to scan the exterior part of said human ear. Preferably, means for merging and/or combining 3D data for the

interior and exterior part of the ear provided, thereby providing a full 3D model of a human ear.

5 For handheld embodiments of this invention, a pistol-like design is ergonomic because the device rests comfortably inside the hand of the operator, with most of the mass resting on top of the hand and/or wrist. In such a design, it is advantageous to be able to orient the above-mentioned posterior reflective in multiple positions. For example, it could be possible to rotate a probe with the posterior reflective element, with or without the step of detaching it from the main body of the scanning device. Detachable probes
10 may also be autoclavable, which is a definitely advantage for scanners applied in humans, e.g., as medical devices. For embodiments of this invention that realize a physically moving focus element by means of a motor, it is advantageous to place this motor inside a grip of the pistol-like shape.

15

Use of motion, gravity, and magnetic sensors

Handheld embodiments of the invention preferably include motion sensors such as accelerometers and/or gyros. . Preferably, these motion sensors are small like
20 microelectromechanical systems (MEMS) motion sensors. The motion sensors should preferably measure all motion in 3D, i.e., both translations and rotations for the three principal coordinate axes. The benefits are:

- 25 A) Motion sensors can detect vibrations and/or shaking. Scans such affected can be either discarded or corrected by use of image stabilization techniques.
- B) Motion sensors can help with stitching and/or registering partial scans to each other. This advantage is relevant when the field of view of the scanner is smaller than the object to be scanned. In this situation, the scanner is applied for small regions of the object (one at a time) that then are combined to obtain
30 the full scan. In the ideal case, motion sensors can provide the required relative rigid-motion transformation between partial scans' local coordinates, because they measure the relative position of the scanning device in each partial scan. Motion sensors with limited accuracy can still provide a first guess for a software-based stitching/ registration of partial scans based on, e.g., the

Iterative Closest Point class of algorithms, resulting in reduced computation time.

- 5 C) Motion sensors can be used (also) as a remote control for the software that accompanies the invention. Such software, for example, can be used to visualize the acquired scan. With the scanner device now acting as a remote control, the user can, for example, rotate and/or pan the view (by moving the remote control in the same way as the object on the computer screen should “move”). Especially in clinical application, such dual use of the handheld scanner is preferable out of hygienic considerations, because the operator
10 avoids contamination from alternative, hand-operated input devices (touch screen, mouse, keyboard, etc).

Even if it is too inaccurate to sense translational motion, a 3-axis accelerometer can provide the direction of gravity relative to the scanning device. Also a magnetometer can provide directional information relative to the scanning device, in this case from the
15 earth’s magnetic field. Therefore, such devices can help with stitching/registration and act as a remote control element.

The present invention relates to different aspects including the scanner device described above and in the following, and corresponding methods, devices, uses
20 and/or product means, each yielding one or more of the benefits and advantages described in connection with the first mentioned aspect, and each having one or more embodiments corresponding to the embodiments described in connection with the first mentioned aspect and/or disclosed in the appended claims.

25 In particular, disclosed herein is a method for obtaining and/or measuring the 3D geometry of at least a part of the surface of an object, said method comprising the steps of:

- generating a probe light incorporating a spatial pattern,
- transmitting the probe light towards the object along the optical axis of
30 an optical system, thereby illuminating at least a part of the object with said pattern,
- transmitting at least a part of the light returned from the object to the camera,
- varying the position of the focus plane of the pattern on the object while
35 maintaining a fixed spatial relation of the scanner and the object,

- obtaining at least one image from said array of sensor elements,
- evaluating a correlation measure at each focus plane position between at least one image pixel and a weight function, where the weight function is determined based on information of the configuration of the spatial pattern;
- 5 - determining by analysis of the correlation measure the in-focus position(s) of:
 - each of a plurality of image pixels in the camera for said range of focus plane positions, or
 - 10 - each of a plurality of groups of image pixels in the camera for said range of focus planes, and
- transforming in-focus data into 3D real world coordinates.

15 Disclosed is also a computer program product comprising program code means for causing a data processing system to perform the method, when said program code means are executed on the data processing system.

20 Disclosed is also a computer program product, comprising a computer-readable medium having stored there on the program code means.

Another aspect of the invention relates to a scanner for obtaining and/or measuring the 3D geometry of at least a part of the surface of an object, said scanner comprising:

- 25 - at least one camera accommodating an array of sensor elements,
- means for generating a probe light,
- means for transmitting the probe light towards the object thereby illuminating at least a part of the object,
- means for transmitting light returned from the object to the camera,
- means for varying the position of the focus plane on the object,
- 30 - means for obtaining at least one image from said array of sensor elements,
- means for:
 - a) determining the in-focus position(s) of:
 - 35 - each of a plurality of the sensor elements for a range of focus plane positions, or

- each of a plurality of groups of the sensor elements for a range of focus plane positions, and
 - b) transforming in-focus data into 3D real world coordinates;
- wherein the scanner further comprises counter-weight means for counter-
- 5 balancing the means for varying the position of the focus plane.

Disclosed is also a method for obtaining and/or measuring the 3D geometry of at least a part of the surface of an object, said method comprising the steps of:

- accommodating an array of sensor elements,
 - 10 - generating a probe light,
 - transmitting the probe light towards the object thereby illuminating at least a part of the object,
 - transmitting light returned from the object to the camera,
 - varying the position of the focus plane on the object,
 - 15 - obtaining at least one image from said array of sensor elements,
 - determining the in-focus position(s) of:
 - each of a plurality of the sensor elements for a range of focus plane positions, or
 - each of a plurality of groups of the sensor elements for a
 - 20 range of focus plane positions, and
 - transforming in-focus data into 3D real world coordinates;
- wherein the method further comprises counter-balancing the means for varying the position of the focus plane.

25

Another aspect of the invention relates to a handheld 3D scanner with a grip at an angle of more than 30 degrees from the scanner's main optical axis, for use in intraoral or in-ear scanning.

30

Brief description of the drawings

Fig. 1: A schematic presentation of a first example embodiment of the device according to the invention.

- Fig. 2: A schematic presentation of a second example embodiment of the device according to the invention (optical correlation).
- Fig. 3: Schematic presentations of example embodiments of patterns according to the invention.
- 5 Fig. 4: A schematic presentation of a first example embodiment of a flat scan tip with large scan length, using a plurality of (dichroic) mirrors and light sources.
[Fig. 5: -- deleted --]
- Fig. 6: A schematic presentation of a third example embodiment of a flat scan tip with a large scan length, using a curved mirror.
- 10 Fig. 7: A schematic presentation of a fourth example embodiment of a flat scan tip with large scan length, using a diffractive grating.
- Fig. 8: A schematic presentation of an example embodiment of a mass-balanced focus lens scanner.
- Fig. 9: A schematic presentation of an example embodiment of a device for
15 simultaneous scanning of a surface shape and color.
- Fig. 12: A schematic presentation of an example embodiment of a device for scanning the at least a part of the external part of the human ear and/or a part of the ear canal a human ear.
- Fig. 13 (a) and (b): Schematics showing how a scanner embodiment can be used to
20 both scan the outer and inner ear, respectively.
- Fig. 14: Schematic of a scanner probe embodiment used to scan a narrow body cavity, such as a human ear.
- Fig. 15: Examples of mirror configurations to be used with a scanner probe.
- Fig. 16: A schematic representation of the reference signal values / weight values per
25 pixel for a checkerboard pattern in an idealized optical system.
- Fig. 17: Illustration of the process of generating a fused reference signal, visualized as images.
- Fig 18: Top: Example image with projected pattern showing on a human tooth. Bottom: The correlation measure for the series of focus lens positions at the group of pixels
30 framed in the top part of the figure.
- Fig. 19: Example fused correlation measure image of an intraoral scene.
- Fig. 20: Example of a handheld intraoral scanner with a pistol-like grip and a removable tip.

It will be understood that the ray traces and lenses depicted in the figures are for purpose of illustration only, and depict optical paths generally in the discussed systems. The ray traces and lens shapes should not be understood to limit the scope of the invention in any sense including the magnitude, direction, or focus of light rays or
5 bundles passing through various optical components, notwithstanding any variations in number, direction, shape, position or size thereof, except as expressly indicated in the following detailed description of the exemplary embodiments illustrated in the drawings.

Detailed description of the drawings

10

A functional hand held 3D surface scanner should preferably have the following properties:

- 1) Telecentricity in the space of the object being scanned,
- 2) possibility to shift the focal plane while maintaining telecentricity and
15 magnification
- 3) simple focusing scheme that involves tuning of optical components only in the handle of the device and not in the probe tip, and
- 4) a total size consistent with a hand held scanning device.

20 The scanner embodiment illustrated in **fig. 1** is a hand-held scanner with all components inside the housing (head) **100**. The scanner head comprises a tip which can be entered into a cavity, a light source **110**, optics **120** to collect the light from the light source, pattern generation means **130**, a beam splitter **140**, an image sensor and electronics **180**, a lens system which transmits and images the light between the
25 pattern, the object being scanned, and the image sensor (camera) **180**. The light from the light source **110** travels back and forth through the optical system **150**. During this passage the optical system images the pattern **130** onto the object being scanned **200** and further images the object being scanned onto the image sensor **181**. The lens system includes a focusing element **151** which can be adjusted to shift the focal
30 imaging plane of the pattern on the probed object **200**. One way to embody the focusing element is to physically move a single lens element back and forth along the optical axis. The device may include polarization optics **160**. The device may include folding optics **170** which directs the light out of the device in a direction different to the optical axis of the lens system, e.g. in a direction perpendicular to the optical axis of the
35 lens system. As a whole, the optical system provides an imaging of the pattern onto the

object being probed and from the object being probed to the camera. One application of the device could be for determining the 3D structure of teeth in the oral cavity. Another application could be for determining the 3D shape of the ear canal and the external part of the ear.

5

The optical axis in fig. 1 is the axis defined by a straight line through the light source **110**, optics **120** and the lenses in the optical system **150**. This also corresponds to the longitudinal axis of the scanner illustrated in fig. 1. The optical path is the path of the light from the light source **110** to the object **220** and back to the camera **180**. The optical path may change direction, e.g. by means of beam splitter **140** and folding optics **170**.

10

The focus element is adjusted in such a way that the image of the pattern on the scanned object is shifted along the optical axis, preferably in equal steps from one end of the scanning region to the other. When the pattern is varied in time in a periodic fashion for a fixed focus position then the in-focus regions on the object will display an spatially varying pattern. The out-of-focus regions will display smaller or no contrast in the light variation. The 3D surface structure of the probed object is determined by finding the plane corresponding to an extremum in the correlation measure for each sensor in the camera's sensor array or each group of sensor in the camera's sensor array when recording the correlation measure for a range of different focus positions **300**. Preferably one would move the focus position in equal steps from one end of the scanning region to the other.

15

20

25

Pattern generation

An embodiment of the pattern generation means is shown in fig. 3a: A transparent wheel with an opaque mask **133** in the form of spokes pointing radially from the wheel center. In this embodiment the pattern is time-varied by rotating the wheel with a motor **131** connected to the wheel with e.g. a drive shaft **132**. The position of the pattern in time may be registered during rotation. This can be achieved by e.g. using a position encoder on the rim of the pattern **134** or obtaining the shaft position directly from motor **131**.

30

Fig. 3b illustrates another embodiment of the pattern generation means: A segmented light source **135**, preferably a segmented LED. In this embodiment the LED surface is

35

imaged onto the object under investigation. The individual LED segments **136** are turned on and off in a fashion to provide a known time-varying pattern on the object. The control electronics **137** of the time varying pattern is connected to the segmented light source via electrical wires **138**. The pattern is thus integrated into the light source
 5 and a separate light source is not necessary.

Fig 3c illustrates a static pattern as applied in a spatial correlation embodiment of this invention. The checkerboard pattern shown is preferred because calculations for this regular pattern are easiest.
 10

Temporal correlation

Fig. 1 is also an exemplary illustration of the temporal correlation wherein an image of the pattern on and/or in the object is formed on the camera. Each individual light sensing element in the camera sees a variation in the signal level corresponding to the variation of the illumination pattern on the object. The variation is periodic in the
 15 exemplary illustration. The light variation for each individual light sensing element will have a constant phase offset relative to the pattern position..

The correlation measure may be obtained by recording n images on the camera during at least one oscillation period. n is an integer number greater than one. The registration of the pattern position for each individual image combined with the phase offset values for each sensing element and the recorded images allows for an efficient extraction of the correlation measure in each individual sensing element in the camera using the following formula,
 20

$$A_j = \sum_{i=1}^n f_{i,j} I_{i,j}$$

Here A_j is the estimated correlation measure of sensing element j , $I_{1,j} \dots I_{n,j}$ are the n recorded signals from sensing element j , $f_{1,j} \dots f_{n,j}$ are the n reference signal values obtained from the knowledge of the pattern configuration for each image recording. f has two indices i,j . The variation of f with the first index is derived from the knowledge of the pattern position during each image recording. The variation of f with the second
 25 index is derived from the knowledge of the pattern geometry which may be determined prior to the 3D scanning.
 30

The focus position corresponding to the pattern being in focus on the object for a single sensor in the camera will be given by an extremum in the recorded correlation measure of that sensor when the focus position is varied over a range of values, preferably in equal steps from one end of the scanning region to the other.

5

Spatial correlation

In an example of the spatial correlation scheme, one image of the object with projected checkerboard pattern is recorded with as high resolution as allowed by the image sensor. The scheme in the spatial correlation is then to analyze groups of pixels in the recorded image and extract the correlation measure in the pattern. An extremum in the obtained correlation measures indicates the in-focus position. For simplicity, one can use a checkerboard pattern with a period corresponding to $n = N \times N$ pixels on the sensor and then analyze the correlation measure within one period of the pattern (in the general case the pattern need not be quadratic $N \times N$). In the best case, it will be possible to align the pattern so that the checkerboard edges coincide with the pixel edges but the scanning principle does not rely upon this. Fig. 16 shows this for the case $n = 4 \times 4 = 16$. For a sensor with $W \times H = 1024 \times 512$ pixels, this would correspond to obtaining 256×128 correlation measure points from one image. Extraction of the correlation measure A_j within an $N \times N$ group of pixels with label j is given by

20

$$A_j = \sum_{i=1}^n f_{i,j} I_{i,j}$$

where $\mathbf{f}_j = (f_{1,j}, \dots, f_{n,j})$ is the reference signal vector obtained from knowledge of the pattern configuration, and $\mathbf{I}_j = (I_{1,j}, \dots, I_{n,j})$ is input signal vector.

To suppress any DC part in the light we prefer that for all j that

$$0 = \sum_{i=1}^n f_{i,j}$$

For the situation depicted in fig. 16 for instance, $f_{i,j} = -1$ for the pixels corresponding to the dark parts of the pattern, and $f_{i,j} = +1$ otherwise. If the pattern edge was not aligned with the edges of the pixels, or if the optical system was not perfect (and thus in all practical applications), then $f_{i,j}$ would assume values between -1 and +1 for some i . A detailed description of how to determine the reference function is given later.

30

Optical correlation

An example of the optical correlation shown in fig. 2. In this embodiment an image is formed on the camera **180** which is a superposition of the pattern **130** with the probed object **200**. In this embodiment the pattern is of a transmissive nature where light is transmitted through the pattern and the image of the pattern is projected onto the object and back again. In particular this involves retransmission of the light through the pattern in the opposite direction. An image of the pattern onto the camera is then formed with the aid of a beam splitter **140**. The result of this arrangement is an image being formed on the camera which is a superposition of the pattern itself and the object being probed. A different way of expressing this is that the image on the camera is substantially a multiplication of an image of the pattern projected onto the object with the pattern itself.

The variation is periodic in the exemplary illustration. The correlation measure between the light variation on the object and the pattern for a given focus distance may be obtained by time integrating the camera signal over a large number of oscillation periods so that exact synchronization of pattern oscillation time and camera integration time is not important. The focus position corresponding to the pattern being in focus on the object for a single sensor in the camera will be given by the maximum recorded signal value of that sensor when the focus position is varied over a range of values, preferably in equal steps from one end of the scanning region to the other.

Finding the predetermined reference function

In the following, the process for computing the reference signal f is described for a spatial correlation embodiment of this invention, and depicted in a stylized way in Figure 17.

The process starts by recording a series of images of the checkerboard pattern as projected, e.g., on a flat surface, preferably oriented orthogonally to the optical axis of the scanner. The images are taken at different positions of the focusing element, in effect covering the entire travel range of said focus element. Preferably, the images are taken at equidistant locations.

As the focus plane generally is not a geometrical plane, different regions of the flat surface will be in focus in different images. Examples of three such images are shown

in Figs 17a – 17c, where **1700** is an in-focus region. Note that in this stylized figure, transitions between regions in and out of focus, respectively, are exaggerated in order to demonstrate the principle more clearly. Also, in general there will be many more images than just the three used in this simple example.

5

In-focus regions within an image are found as those of maximum intensity variance (indicating maximum contrast) over the entire said series of images. The region to compute variance over need not be the same as the pixel group dimension used in spatial correlation, but should be large enough to contain the both dark and light regions of the pattern, and it must be the same for all images in the series.

10

Finally, a “fused image” (Fig 17d) is generated by combining all the in-focus regions of the series (17a – 17c). Note that in real applications, the fused image will generally not be a perfect checkerboard of black and white, but rather include intermediate gray values as caused by an imperfect optical system and a checkerboard that is not perfectly aligned with the camera sensors. An example of part of a real fused image is shown in fig 17e.

15

The pixel intensities within this image can be interpreted as a “weight image” with same dimensions as the original image of the pattern. In other words, the pixel values can be interpreted as the reference signal and the reference vector / set of weight values $\mathbf{f}_j = (f_{1,j}, \dots, f_{n,j})$ for the n pixels in the pixel group with index j can be found from the pixel values.

20

For convenience in the implementation of the calculations, especially when carried out on an FPGA, the fused image can be sub-divided into pixel groups. The DC part of the signal can then be removed by subtracting the within-group intensity mean from each pixel intensity value. Furthermore, one can then normalize by dividing by the within-group standard deviation. The thus processed weight values are an alternative description of the reference signal..

25

30

Because of the periodic nature of the “fused image” and thus the “weight image”, the latter can be compressed efficiently, thus minimizing memory requirements in the electronics that can implement the algorithm described here. For example, the PNG algorithm can be used for compression.

35

The “correlation image”

An “correlation” image is generated based on the “fused image” and the set of images recorded with the camera during a scan. For spatial correlation based on an $N \times N$ checkerboard pattern, recall that within-group correlation measure is

$$A_j = \sum_{i=1}^N \sum_{l=1}^N f_{i,j} I_{i,j},$$

where $f_j = (f_{1,j}, \dots, f_{n,j})$ are values from the fused image, and $I_j = (I_{1,j}, \dots, I_{n,j})$ are values from a recorded image on the camera. The pixel groupings used in any DC removal and possibly normalization that yielded the fused image are the same as in the above calculation. For each image recorded by the scanner during a sweep of the focusing element, there will thus be an array of $(H/N) \times (W/N)$ values of A . This array can be visualized as an image.

Fig. 18 (top section) shows one example correlation measure image, here of part of a human tooth and its edge. A pixel group of 6×6 pixels is marked by a square **1801**. For this example pixel group, the series of correlation measures A over all images within a sweep of the focusing element is shown in the chart in the bottom section of Fig 18 (cross hairs). The x-axis on the chart is the position of the focusing element, while the y-axis shows the magnitude of A . Running a simple Gaussian filter over the raw series results in a smoothed series (solid line). In the figure the focus element is in the position that gives optimal focus for the example group of pixels. This fact is both subjectively visible in the picture, but also determined quantitatively as the maximum of the series of A . The vertical line **1802** in the bottom section of Fig 18 indicates the location of the global extremum and thus the in-focus position. Note that in this example, the location of the maxima in the smoothed and the raw series, respectively, are visually indistinguishable. In principle, however, it is possible and also advantageous to find the maximum location from the smoothed series, as that can be between two lens positions and thus provide higher accuracy.

The array of values of A can be computed for every image recorded in a sweep of the focus element. Combining the global extrema (over all images) of A in all pixel groups in the same manner the fused image was combined, one can obtain a pseudo-image of dimension $(H/N) \times (W/N)$. This we call the “fused correlation image”. An example of a

fused correlation image of some teeth and gingiva is shown in Figure 19. As can be seen, it is useful for visualization purposes.

Increasing field of view

5 For the scan head to be entered into a small space such as the oral cavity of a patient it is necessary that the tip of the scan head is sufficiently small. At the same time the light out of the scan head need to leave the scan head in a direction different from the optical axis, e.g. at a direction perpendicular to the optical axis. In one embodiment of the invention a 45 degree mirror is used as folding optics **170** direct the light path onto
10 the object. In this embodiment the height of the scan tip need to be at least as large as the scan length.

Another embodiment of the invention is shown in fig. 4. This embodiment of the invention allows for a scan tip with a smaller height (denoted b in the figure) than the scan length (denoted a in the figure). The light from two sources **110** and **111** emitting light of different colors/wavelengths is merged together using a suitably coated plate (e.g. a dichroic filter) **112** that transmit the light from **110** and reflects the light from **111**.
15 At the scan tip a suitably coated plate (e.g. a dichroic filter) **171** reflects the light from one source onto the object and transmits the light from the other source to a mirror at the end of the scan tip **172**. During scanning the focus position is moved such that the light from **110** is used to project an image of the pattern to a position below **171** while **111** is switched off. The 3D surface of the object in the region below **171** is recorded. Then **110** is switched off and **111** is switched on and the focus position is moved such that the light from **111** is used to project an image of the pattern to a position below
20 **172**. The 3D surface of the object in the region below **172** is recorded. The region covered with the light from **110** and **111** respectively may partially overlap.

Another embodiment of the invention that allows for a scan tip with a smaller height (denoted b in the figure) than the scan length (denoted a in the figure) is shown in fig.
30 6. In this embodiment the fold optics **170** comprises a curved fold mirror **173** that may be supplemented with one or two lens elements **175** and **176** with surfaces that may be aspherical to provide corrected optical imaging.

Another embodiment of the invention that allows for a scan tip with a smaller height
35 (denoted b in the figure) than the scan length (denoted a in the figure) is shown in fig.

7. In this embodiment the fold optics **170** comprises a grating **177** that provides anamorphic magnification so that the image of the pattern on the object being scanned is stretched. The grating may be blazed. The light source **110** needs to be monochromatic or semi-monochromatic in this embodiment.

5

Achieving high spatial contrast of pattern projected onto difficult objects

High spatial contrast of the in-focus pattern image on the object is necessary to obtain a high correlation measure signal based on the camera pictures. This in turn is necessary to obtain a good estimation of the focus position corresponding to the position of an extremum of the correlation measure. This necessary condition for successful scanning is easily achieved in objects with a diffuse surface and negligible light penetration. For some objects, however, it is difficult to achieve high spatial contrast, or more generally variation.

15 A difficult kind of object, for instance, is an object displaying multiple scattering with a light diffusion length large compared to the smallest feature size of the spatial pattern imaged onto the object. A human tooth is an example of such an object. The human ear and ear canal are other examples. Improved spatial variation in such objects can be achieved by preferential imaging of the specular surface reflection from the object on the camera. An embodiment of the invention applies polarization engineering shown in fig. 1. In this embodiment the beam splitter **140** is a polarizing beam splitter that transmits respectively reflects two orthogonal polarization states, e.g. S- and P-polarization states. The light transmitted through the lens system **150** is thus of a specific polarization state. Before leaving the device the polarization state is changed with a retardation plate **160**. A preferred type of retardation plate is a quarter wave retardation plate. A linearly polarized light wave is transformed into a circularly polarized light wave upon passage of a quarter wave plate with an orientation 45 degrees of its fast axis to the linear polarization direction. A specular reflection from the object has the property that it flips the helicity of a circularly polarized light wave. Upon passage of the quarter wave retardation plate by the specularly reflected light the polarization state becomes orthogonal to the state incident on the object. For instance an S-polarization state propagating in the downstream direction toward the object will be returned as a P-polarization state. This implies that the specularly reflected light wave will be directed towards the image sensor **181** in the beam splitter **140**. Light that enters into the object and is reflected by one or more scattering events becomes

depolarized and one half of this light will be directed towards the image sensor **181** by the beam splitter **140**.

Another kind of difficult object is an object with a shiny or metallic-looking surface. This is particularly true for a polished object or an object with a very smooth surface. A piece of jewelry is an example of such an object. Even very smooth and shiny objects, however, do display an amount of diffuse reflection. Improved spatial contrast in such objects can be achieved by preferential imaging of the diffuse surface reflection from the object on the camera. In this embodiment the beam splitter **140** is a polarizing beam splitter that transmits respectively reflects two orthogonal polarization states, e.g. S- and P-polarization states. The light transmitted through the lens system **150** is thus of a specific polarization state. A diffuse reflection from the object has the property that it loses its polarization. This implies that half of the diffusely reflected light wave will be directed towards the image sensor **181** in the beam splitter **140**. Light that enters into the object and is reflected by specular polarization preserves its polarization state and thus none of it will be directed towards the image sensor **181** by the beam splitter **140**.

Reducing shaking caused by focus element

During scanning the focus position is changed over a range of values, preferably provided by a focusing element **151** in the optical system **150**. Fig. 8 illustrates an example of how to reduce shaking caused by the oscillating focus element. The focusing element is a lens element **152** that is mounted on a translation stage **153** and translated back and forth along the optical axis of said optical system with a mechanical mechanism **154** that includes a motor **155**. During scanning the center of mass of the handheld device is shifted due to the physical movement of the lens element and holder. This results in an undesirable shaking of the handheld device during scanning. The situation is aggravated if the scan is fast, e.g. a scan time of less than one second. In one implementation of the invention the shifting of the center of mass is eliminated by moving a counter-weight **156** in a direction opposite to the lens element in such a way that the center of mass of the handheld device remains fixed. In the preferred implementation the focus lens and the counter-weight are mechanically connected and their opposite movement is driven by the same motor.

Color measurement

An embodiment of a color 3D scanner is shown in fig. 9. Three light sources **110**, **111**, and **113** emit red, green, and blue light. The light sources are may be LEDs or lasers. The light is merged together to overlap or essentially overlap. This may be achieved by means of two appropriately coated plates **112** and **114**. Plate **112** transmits the light
5 from **110** and reflects the light from **111**. Plate **114** transmits the light from **110** and **111** and reflects the light from **113**. The color measurement is performed as follows: For a given focus position the amplitude of the time-varying pattern projected onto the probed object is determined for each sensor element in the sensor **181** by one of the above mentioned methods for each of the light sources individually. In the preferred
10 embodiment only one light source is switched on at the time, and the light sources are switched on after turn. In this embodiment the optical system **150** may be achromatic. After determining the amplitude for each light source the focus position is shifted to the next position and the process is repeated. The color expressed as e.g. an RGB color coordinate of each surface element can be reconstructed by appropriate weighting of
15 the amplitude signal for each color corresponding the maximum amplitude.

One specific embodiment of the invention only registers the amplitude for all colors at an interval of P focus positions; while one color is selected for determination of the amplitude at all focus positions. P is a number which could be e.g. 3, 5, or 10. This
20 results in a color resolution which is less than the resolution of the surface topology. Color of each surface element of the probed object is determined by interpolation between the focus positions where full color information is obtained. This is in analogy to the Bayer color scheme used in many color digital cameras. In this scheme the color resolution is also less than the spatial resolution and color information need to be
25 interpolated.

A simpler embodiment of the 3D color scanner does not register full color information and employs only two light sources with different colors. An example of this is a dental scanner that uses red and blue light to distinguish hard (tooth) tissue from soft (gum)
30 tissue.

Ear scanner embodiment

Figs. 12-15 schematically illustrate an embodiment of a time-varying structured light illumination-based scanner for direct scanning of human ears by scanning both the
35 exterior (outer) and interior (inner) part of a human ear by use of a common scanner

exterior handle and a detachable probe. This embodiment is advantageous in that it allows for non-intrusive scanning using a probe designed to be inserted into small cavities, such as a human ear. This is done in part by positioning the bulky and essential parts of the scanner, such as the scanner camera, light source, electronics and focusing optics outside the closely confined part of the ear canal.

The ability to scan the outer and inner part of human ears and make a virtual or real model of the ear is essential in the design of modern custom-fitted hearing aid (e.g. ear shell or mold). Today, scanning of ears is performed in a two-step process where a silicone impression of the ear is taken first and the impression is subsequently scanned using an external scanner in a second step. The process of making the impression suffers from several drawbacks which will shortly be described in the following. One major drawback comes from frequent poor quality impressions taken by qualified clinic professionals due to the preparation and techniques required. Inaccuracies may arise because the impression material is known to expand during hardening and that deformation and creation of fractures in the impression are often created when the impression is removed from the ear. Another drawback is related to health risks involved with taking the impression due to irritation and allergic responses, damage to the tympanic membrane and infections. Finally, the impression process is an uncomfortable experience for many patients, especially for young children, who often require impressions taken at regular intervals (e.g. every four months) to accommodate the changing dimensions of the ear canal. In short, these drawbacks can be overcome if it is possible to scan the outer and inner ear in a non-intrusive way and obtain a registration between the inner and outer ear surfaces.

The following is not restricted to ear scanning but can be used to scan any small bodily cavity. Fig. 12 is a schematic of an embodiment of such a scanner. The scanner consists of two main parts – a scanner exterior **1001** and a scanner probe **1002**. The scanner exterior may be used without the probe to obtain a larger field-of-view needed e.g. to scan the exterior part of the ear **1102**, or the first part of the ear canal up to the first bend. The large field-of-view of the scanner exterior is important to obtain good registration between individual sub-scans and high global accuracy. By attaching a scanner probe **1202** to the scanner exterior **1201**, the combined scanner allows for scanning of small and bent cavity surfaces, such as the interior part of an ear **1203**. In

this way and using the same system, the combined scanner exterior and probe are able to both scan larger external areas along with smaller internal areas.

In fig. 12 the exterior part of the scanner embodiment **1001** consists of a diverging light source **1003** (laser, LED, Tungsten or another type) which is collimated using
5 collimation optics **1004**. The collimated light is used to illuminate a transparent object **1005** (e.g. glass) with an opaque pattern, e.g. fringes on it. The pattern is subsequently imaged onto the object to be scanned using a suitable optical system. The pattern is observed using a similar optical system and a camera **1006**, where the latter is positioned outside the cavity. The 3D information is obtained from the 2D images by
10 observing the light oscillation created by the movement of the pattern across the scan object as contained in the individual pixel amplitude.

To facilitate movement of the pattern, the fringe pattern **1005** is rotating in one embodiment. In another embodiment, the fringe pattern is positioned on a translating
15 plate that moves in a plane perpendicular to the optical axis with a certain oscillation frequency. The light to and from the scan object is projected through a beam splitter arrangement **1007**, which consists of a prism cube in one embodiment and in another embodiment consists of an angled plate or membrane. The beam splitter serves to transmit the source light further down the system, while at the same time guide the
20 reflected light from the scan object back to the camera, which is positioned on an axis perpendicular to the axis of the light source and beam splitter.

To move the focus plane the scanner exterior includes focusing optics, which in one embodiment consists of a single movable lens **1008**. The purpose of the focusing
25 optics is to facilitate movement of the plane of focus for the whole imaging system in the required scanning range and along the optical axis. In one embodiment, the focusing optics of the scanner exterior **1101** includes an objective that can focus the light directly, without any use of additional optics, as shown in fig. 13a. In another embodiment, the scanner exterior is supplied with a wide-angle objective designed with
30 a large field-of-view, e.g. sufficiently large for scanning the exterior part of a human ear **1102**.

The optical part of the scanner probe consists of an endoscopic optical relay system **1009** followed by a probe objective **1010**, both of which are of sufficiently small
35 diameter to fit into the canal of a human ear. These optical systems may consist of both

a plurality of optical fibers and lenses and serve to transport and focus the light from the scanner exterior onto the scan object **1014** (e.g. the interior surface of an ear), as well as to collimate and transport the reflected light from the scan object back to the scanner exterior. In one embodiment, the probe objective provides telecentric
5 projection of the fringe pattern onto the scan object. Telecentric projection can significantly ease the data mapping of acquired 2D images to 3D images. In another embodiment, the chief rays (center ray of each ray bundle) from the probe objective are diverging (non-telecentric) to provide the camera with an angle-of-view larger than zero, as shown in fig. 13a.

10

The position of the focus plane is controlled by the focusing optics **1008** and can be moved in a range large enough to at least coincide with the scan surface **1014**. A single sub-scan is obtained by collecting a number of 2D images at different positions of the focus plane and at different positions of the fringe pattern, as previously
15 described. As the focus plane coincides with the scan surface at a single pixel position, the fringe pattern will be projected onto the surface point in-focus and with high contrast, thereby giving rise to a large variation, or amplitude, of the pixel value over time. For each pixel it is thus possible to identify individual settings of the focusing optics for which each pixel will be in-focus. By using knowledge of the optical system, it
20 is possible to transform the contrast information vs. position of the focus plane into 3D surface information, on an individual pixel basis.

In one embodiment, a mirror arrangement **1011**, consisting of a single reflective mirror, or prism, or an arrangement of mirrors, are located after the probe objective **1010**. This
25 arrangement serves to reflect the rays to a viewing direction different from that of the of the probe axis. Different example mirror arrangements are found in figs. 15a – 15d. In one particular embodiment, the angle between the mirror normal and the optical axis is approximately 45 degrees, thus providing a 90 degree view with respect to the probe axis - an arrangement ideal for looking round corners. A transparent window **1012** is
30 positioned adjacent to the mirror and as part of the probe casing/shell, to allow the light to pass between the probe and the scan object, while keeping the optics clean from outside dirt particles.

To reduce the probe movement required by a scanner operator, the mirror
35 arrangement may be rotated using a motor **1013**. In one embodiment, the mirror

arrangement rotates with constant velocity. By full rotation of a single mirror, it is in this way possible to scan with 360 degree coverage around the probe axis without physically moving the probe. In this case, the probe window **1012** is required to surround / go all around the probe to enable viewing in every angle. In another
5 embodiment, the mirror rotates with a certain rotation oscillation frequency. In yet another embodiment, the mirror arrangement tilt with respect to the probe axis is varied with a certain oscillation frequency.

A particular embodiment uses a double mirror instead of a single mirror (figs. 15b and
10 15d). In a special case, the normal of the two mirrors are angled approx. 90 degrees with respect to each other. The use of a double mirror helps registration of the individual sub-scans, since information of two opposite surfaces in this way is obtained at the same time. Another benefit of using a double mirror is that only 180 degrees of mirror rotation is required to scan a full 360 degrees. A scanner solution employing
15 double mirrors may therefore provide 360 degrees coverage in less time than single mirror configurations.

"Pistol-like" grip

Fig. 20 shows an embodiment of the scanner with a pistol-like grip **2001**. This form is particularly ergonomic. The scanner in Fig. 20 is designed for intra-oral scanning of
20 teeth. The tip **2002**.can be removed from the main body of the scanner and can be autoclaved. Furthermore, the tip can have two positions relative to the main body of the scanner, namely looking down (as in Fig 20) and looking up. Therefore, scanning the upper and the lower mouth of a patient is equally comfortable for the operator. Note
25 that the scanner shown in Fig. 20 is an early prototype with several cables attached for testing purposes only.

Although some embodiments have been described and shown in detail, the invention is
30 not restricted to them, but may also be embodied in other ways within the scope of the subject matter defined in the following claims. In particular, it is to be understood that other embodiments may be utilised and structural and functional modifications may be made without departing from the scope of the present invention.

35 In device claims enumerating several means, several of these means can be embodied by one and the same item of hardware. The mere fact that certain measures are

recited in mutually different dependent claims or described in different embodiments does not indicate that a combination of these measures cannot be used to advantage.

5 It should be emphasized that the term "comprises/comprising" when used in this specification is taken to specify the presence of stated features, integers, steps or components but does not preclude the presence or addition of one or more other features, integers, steps, components or groups thereof.

10 The features of the method described above and in the following may be implemented in software and carried out on a data processing system or other processing means caused by the execution of computer-executable instructions. The instructions may be program code means loaded in a memory, such as a RAM, from a storage medium or from another computer via a computer network. Alternatively, the described features may be implemented by hardwired circuitry instead of software or in combination with
15 software.

Claims

1. A scanner for obtaining and/or measuring the 3D geometry of at least a part of the surface of an object, said scanner comprising:
- 5
- at least one camera accommodating an array of sensor elements,
 - means for generating a probe light incorporating a spatial pattern,
 - means for transmitting the probe light towards the object thereby illuminating at least a part of the object with said pattern in one or more configurations,
- 10
- means for transmitting at least a part of the light returned from the object to the camera,
 - means for varying the position of the focus plane of the pattern on the object while maintaining a fixed spatial relation of the scanner and the object,
- 15
- means for obtaining at least one image from said array of sensor elements,
 - means for evaluating a correlation measure at each focus plane position between at least one image pixel and a weight function, where the weight function is determined based on information of the configuration
- 20
- data processing means for:
 - a) determining by analysis of the correlation measure the in-focus position(s) of:
 - each of a plurality of image pixels for a range of focus
- 25
- each of a plurality of groups of image pixels for a range of focus plane positions, and
 - b) transforming in-focus data into 3D real world coordinates.
- 30
2. A scanner according to claim 1, wherein the light returned from the object to the camera is light that is reflected and/or scattered and/or fluorescence light and/or phosphorescence light.

3. A scanner according to claims 1 or 2, wherein the means for evaluating a correlation measure is a data processing means.
- 5 4. A scanner according to claims 1 or 2, wherein the means for evaluating a correlation measure is an optical means.
- 10 5. A scanner according to any of the preceding claims, wherein the correlation measure is found mathematically substantially as an at least local extremum position of an optionally smoothed series of dot products computed for a plurality of said focus plane positions.
- 15 6. A scanner according to the previous claim, wherein each dot product is computed from a signal vector with more than one element representing sensor signals and a weight vector of same length as said signal vector of weights.
- 20 7. A scanner according to any of the preceding claims, wherein the pattern is varying in time.
8. A scanner according to the previous claim, wherein the time varying pattern is periodically varying in time.
- 25 9. A scanner according to any of the preceding claims, wherein the pattern is static.
10. A scanner according to any of the preceding claims, wherein the means for transmitting light returned from the object to the camera comprises means for imaging onto the camera said illuminated part of the object with said pattern.
- 30 11. A scanner according to any of the preceding claims, wherein the means for transmitting light returned from the object to the camera comprises means for imaging onto the camera the pattern itself and a superposition of light returned from the object to the camera such that the image on the camera substantially is a multiplication of said illuminated part of the object with said pattern and the pattern itself.

12. A scanner according to any of the preceding claims, wherein the embedded spatial structure of said pattern is varying in time.
- 5 13. A scanner according to any of the preceding claims, comprising at least one light source and pattern generation means.
- 10 14. A scanner according to the previous claim, wherein light from said probe light generating means is transmitted through said pattern generation means thereby generating the pattern.
- 15 15. A scanner according to any of claims 13 or 14, wherein said pattern generation means comprises a mask of transparent and opaque parts.
- 16 16. A scanner according to the previous claim, wherein said opaque parts absorb incident light.
- 20 17. A scanner according to any of the preceding claims, wherein said pattern possess translational and/or rotational periodicity.
- 25 18. A scanner according to any of the preceding claims, wherein said pattern illuminating the object is varying in time by translating and/or rotating said pattern.
- 30 19. A scanner according to any of claims 13-18, wherein light returned from the object is retransmitted through said pattern generating means before being imaged on said camera, preferably retransmitted in the opposite direction as the probe light.
20. A scanner according to any of the preceding claims, wherein the image of the pattern illuminating the object is coinciding with an image of the pattern itself.
21. A scanner according to any of the preceding claims, further comprising means for synchronizing exposure time of said sensor elements with pattern oscillation time.

22. A scanner according to any of the preceding claims, wherein exposure time of said sensor elements is an integer number of light oscillation cycles.
- 5 23. A scanner according to any of the preceding claims, wherein exposure time of said sensor elements is a large number of light oscillation cycles, such as at least 10 times the light oscillation cycle, such as at least 100 times the light oscillation cycle.
- 10 24. A scanner according to any of claims 13-23, wherein light from the light source is transmitted through the pattern generation means thereby generating the pattern.
- 15 25. A scanner according to any of the preceding claims, wherein the focus plane of the camera is adapted to be moved synchronously with the focus plane of the pattern.
- 20 26. A scanner according to any of the preceding claims, wherein the object is an anatomical object, such as an ear canal, or a dental object, such as teeth.
- 25 27. A scanner according to any of the preceding claims, comprising an optical system for transmitting the probe light towards the object and/or for imaging light returned from the object to the camera.
- 30 28. A scanner according to any of the preceding claims, further comprising at least one beam splitter located in the optical path.
- 35 29. A scanner according to any of the preceding claims, wherein an image of the object is formed in the camera by means of at least one beam splitter.
- 30 30. A scanner according to any of the preceding claims, wherein the pattern is transmitted towards the object along the same optical axis as reflected light transmitted from the object to the camera.
- 35 31. A scanner according to any of the preceding claims, wherein the optical system comprises a lens system.

32. A scanner according to any of the preceding claims, wherein one lens system transmits the pattern towards the object and images light returned from the object to the camera.
- 5 33. A scanner according to any of the preceding claims, wherein one lens system transmits the pattern towards the object and images the light returned from the object to the pattern generating means.
- 10 34. A scanner according to claims 31-33, wherein the lens system is telecentric or near telecentric.
35. A scanner according to any of the preceding claims, wherein the pattern is transmitted in the opposite direction of light imaged from the object to the camera.
- 15 36. A scanner according to any of the preceding claims, wherein the pattern is transmitted in the opposite direction of light imaged from the object to the pattern generating means.
- 20 37. A scanner according to any of the preceding claims, wherein the sensor signal is an integrated light intensity substantially reflected from the surface of the object.
- 25 38. A scanner according to any of the preceding claims, wherein the focus plane position is periodically varied with a predefined frequency.
39. A scanner according to the previous claim, wherein said frequency is at least 1 Hz, such as at least 2 Hz, 3, 4, 5, 6, 7, 8, 9 or at least 10 Hz, such as at least 20, 40, 60, 80 or at least 100 Hz.
- 30 40. A scanner according to any of the preceding claims, further comprising at least one focus element.
- 35 41. A scanner according to the previous claim, wherein the focus element is part of the lens system.

42. A scanner according to any of claims 40-41 further comprising means for adjusting and controlling the focus element.
- 5 43. A scanner according to any of claims 40-42, wherein the focus element is a single lens.
44. A scanner according to any of claims 40-43, further comprising a translation stage for adjusting the position of the focus element.
- 10 45. A scanner according to any of claims 40-44, wherein the focus element is translated back and forth along the optical axis.
46. A scanner according to any of claims 31-45, wherein the lens system is telecentric or near telecentric for all focus plane positions.
- 15 47. A scanner according to any of claims 40-46, further comprising focus gearing.
48. A scanner according to the previous claim, wherein the focus gearing is between 0.1 and 100, such as between 0.1 and 1, such as between 1 and 10, such as
20 between 2 and 8, such as between 3 and 6, such as least 10, such as at least 20.
49. A scanner according to any of claims 40-48, further comprising means for reducing and/or eliminating the vibration and/or shaking from the focus element adjustment system, thereby increasing the stability of the scanner.
- 25 50. A scanner according to any of claims 40-49, further comprising means for fixing and/or maintaining the centre of mass of the focus element adjustment system.
- 30 51. A scanner according to any of claims 40-50, further comprising means for reducing and/or eliminating the first order, second order, third order and/or higher order vibration and/or shaking from the focus element adjustment system, thereby increasing the stability of the scanner.

52. . A scanner according to any of the preceding claims, further comprising a counter-weight to substantially counter-balance movement of the focus element.
53. A scanner according to the previous claim, further comprising means for
5 translating the counter-weight opposite to movement of the focus element.
54. A scanner according to claims 52 or 53, wherein the counter-weight and the focus element are connected and driven by the same translation means.
- 10 55. A scanner according to any of claims 40-54, wherein the focus element is a liquid lens.
56. A scanner according to any of claims 13-55, wherein the pattern generation
15 means comprises at least one translucent and/or transparent pattern element with an opaque mask.
57. A scanner according to any of the preceding claims, wherein the pattern is a static line pattern or a static checkerboard pattern.
- 20 58. A scanner according to claims 56 or 57, further comprising means for rotating and/or translating the pattern element.
59. A scanner according to any of claims 56-58, wherein said pattern element is a
25 wheel.
60. A scanner according to any of claims 56-59, wherein said mask possesses rotational and/or translational periodicity.
61. A scanner according to any of claims 56-60, wherein said mask comprises a
30 plurality of radial spokes, preferably arranged in a symmetrical order.
62. A scanner according to any of claims 56-61, wherein the pattern element is located in the optical path.

63. A scanner according to any of claims 56-62, wherein light is transmitted through the pattern element, preferably transmitted transversely through the pattern element.
- 5 64. A scanner according to any of claims 56-63, wherein the time varying pattern is generated by rotating and/or translating the pattern element.
65. A scanner according to any of the preceding claims, comprising at least one segmented light source, such as a segmented LED.
- 10 66. A scanner according to the previous claim, wherein the pattern is generated by means of said segmented light source(s).
67. A scanner according to any of claims 65 or 66, wherein the time varying pattern is generated by switching on and off individual segments of the segmented light source(s).
- 15 68. A scanner according to any of the claims 7 to 67, further comprising means for synchronizing the time varying pattern oscillation with the integration time of a sensor element.
- 20 69. A scanner according to any of the claims 13 to 68, further comprising means for registering and/or monitoring the phase and/or the position and/or the angular position of the time varying pattern and/or the pattern generation means.
- 25 70. A scanner according to any of the claims 56 to 69, wherein the phase and/or the position and/or the angular position of the time varying pattern and/or the pattern element is registered by means of a position encoder on the pattern element.
- 30 71. A scanner according to any of the claims 7 to 70, further comprising means for sampling each of a plurality of the sensor elements a plurality of times during one pattern oscillation period, preferably sampled an integer number of times, such as sampling 2, 3, 4, 5, 6, 7 or 8 times during each pattern oscillation period, thereby determining the correlation measure using the formula,

$$A_j = \sum_{i=1}^n f_{i,j} I_{i,j}$$

where n is the number of times sampled, A_j is the estimated correlation measure of sensing element j , $f_{1,j}, \dots, f_{n,j}$ are the values of the weight function based on information of the configuration of the spatial pattern at each of the times sampled, and $I_{1,j}, \dots, I_{n,j}$ are the recorded sensor signals at each of the times sampled.

72. A scanner according to any of the preceding claims, wherein at least a part of the object surface is imaged in the camera.
73. A scanner according to any of the preceding claims, wherein a superposition of the pattern with at least a part of the object surface is imaged in the camera.
74. A scanner according to any of the claims 13 to 73, wherein light reflected from the object is retransmitted through the pattern generating means before entering the camera, preferably retransmitted in the opposite direction.
75. A scanner according to any of the claims 7 to 74, further comprising means for recording each of a plurality of the sensor elements over a plurality of pattern oscillation periods, such as up to 2, 5, 10, 20, 50, 100, 250, 500, 1000, 5000 or up to 10000 pattern oscillation periods.
76. A scanner according to the previous claim, further comprising means for determining the maximum signal value of each of a plurality of the sensor elements over a range of focus plane positions.
77. A scanner according to any of the preceding claims, wherein the resolution of the measured 3D geometry is equal to the resolution of the camera.
78. A scanner according to any of the preceding claims, wherein the resolution of the measured 3D geometry is lower than the resolution of the camera, such as at least 2 times lower, such as at least 3 times lower, such as at least 4 times lower, such as at least 5 times lower.

79. A scanner according to any of the preceding claims, wherein the sensor element array is divided into groups of sensor elements, preferably rectangular groups, such as square groups of sensor elements, preferably adjacent sensor elements.
- 5 80. A scanner according to any of the preceding claims, wherein the image of the pattern, such as a line pattern or a checkerboard pattern, is aligned with the rows and/or the columns of the array of sensor elements.
81. A scanner according to any of the preceding claims, wherein at least one spatial
10 period of the pattern corresponds to a group of sensor elements.
82. A scanner according to any of the preceding claims, wherein one or more edges of the pattern is aligned with and/or coincide with one or more edges of the array of sensor elements.
15
83. A scanner according to any of the preceding claims, wherein the correlation measure within a group of sensor elements is determined by means of the following formula: $A_j = \sum_{i=1}^n f_{i,j} I_{i,j}$, where A_j is the correlation measure of the
20 group of sensor elements with label j , n is the number of sensor elements in the group, $f_{1,j}, \dots, f_{n,j}$ are the values of the weight function based on information of the configuration of the spatial pattern, and $I_{1,j}, \dots, I_{n,j}$ are the recorded sensor signals at each of the sensor elements in the group.
- 25 84. A scanner according to the previous claim, wherein integration of the weight function over a group of sensor elements is zero, i.e. $0 = \sum_{i=1}^n f_{i,j}$, for the group with label j , thereby suppressing the DC part of the correlation measure.
85. A scanner according to any of the preceding claims, further comprising means for
30 selective imaging of specularly and/or diffusively reflected light.
86. A scanner according to any of the preceding claims, further comprising means for polarizing the probe light, such as a polarizing element.

87. A scanner according to any of the preceding claims, further comprising at least one polarizing beam splitter.
- 5 88. A scanner according to any of the preceding claims, wherein an image of the object is formed in the camera by means of at least one polarizing beam splitter.
89. A scanner according to any of the preceding claims, further comprising means for changing the polarization state of the probe light and/or the light reflected from the object.
- 10 90. A scanner according to any of the preceding claims, further comprising a retardation plate and a linearly polarizing element, located in the optical path, a retardation plate such as a quarter wave retardation plate.
- 15 91. A scanner according to any of the preceding claims, further comprising at least one light reflecting element, preferably located along the optical axis, for directing the probe light and/or imaging an object in a direction different from the optical axis, a light reflecting element such as a mirror.
- 20 92. A scanner according to the previous claim, further comprising means for increasing the extension of the scanned surface in the direction of the optical axis.
- 25 93. A scanner according to any of the preceding claims, comprising at least two light sources, such as light sources with different wavelengths and/or different polarization.
- 30 94. A scanner according to the previous claim, further comprising control means for controlling said at least two light sources.
- 35 95. A scanner according to any of claims 93 or 94, further comprising means for combining and/or merging light from the at least two light sources, such as light sources with different wavelengths and/or different polarization states.

96. A scanner according to any of claims 93 to 95, further comprising means for separating light from at least two light sources, such as light sources with different wavelengths and/or different polarization states.
- 5 97. A scanner according to any of the preceding claims, further comprising at least one optical device which is partially light transmitting and partially light reflecting, said optical device preferably located along the optical axis, an optical device such as a coated mirror or coated plate.
- 10 98. A scanner according to the previous claim, comprising at least two of said optical devices, said optical devices preferably displaced along the optical axis.
- 15 99. A scanner according to claim 97 or 98, wherein at least one of said optical devices transmits light at certain wavelengths and/or polarizations and reflects light at other wavelengths and/or polarizations.
- 20 100. A scanner according to any of claims 97 to 99, comprising at least a first and a second light source, said light sources having different wavelength and/or polarization, and wherein a first optical device located along the optical path reflects light from said first light source in a direction different from the optical axis and transmits light from said second light source, and a second optical device located further down the optical path reflects light from said second light source in a direction different from the optical axis.
- 25 101. A scanner according to the previous claim, wherein said first and second optical devices reflect the probe light in parallel directions, preferably in a direction perpendicular to the optical axis, thereby imaging different parts of the object surface.
- 30 102. A scanner according to the previous claim, wherein said different parts of the object surface are at least partially overlapping.

103. A scanner according to any of claims 93 to 102, comprising control means for providing a coordination of the light sources and the focus element.
- 5 104. A scanner according to any of the preceding claims, further comprising at least one curved fold mirror for directing the probe light and/or imaging an object in a direction different from the optical axis, such as in a direction perpendicular to the optical axis.
- 10 105. A scanner according to the previous claim, further comprising one or more optical elements, such as lenses, with surfaces that may be aspherical to provide corrected optical imaging.
- 15 106. A scanner according to any of the preceding claims, further comprising at least one grating for directing the probe light and/or imaging an object in a direction different from the optical axis, such as in a direction perpendicular to the optical axis.
- 20 107. A scanner according to the previous claim, wherein the grating provides anamorphic magnification, whereby the image of the pattern on the object being scanned is stretched.
108. A scanner according to claims 106 or 107, wherein the grating is blazed.
- 25 109. A scanner according to any of the preceding claims, wherein the point of emission of probe light and the point of accumulation of reflected light being located on a probe, said probe being adapted to be entered into a cavity, such as a body cavity.
- 30 110. A scanner according to the previous claim, wherein the probe is adapted to scan one or more objects in a cavity, such as teeth in a mouth.
111. A scanner according to claim 109, wherein the probe is adapted to scan at least a part of the surface of a cavity, such as an ear canal.
- 35 112. A scanner according to any of the preceding claims, comprising:

- a) a housing accommodating the camera, pattern generation means, focus varying means and data processing means, and
- b) at least one probe accommodating a first optical system.

- 5 113. A scanner according to the previous claim, wherein the housing comprises a second optical system.
114. A scanner according to any of claims 112 or 113, wherein the probe is endoscopic.
- 10 115. A scanner according to any of claims 112 to 114, wherein the probe comprises at least one optical fibre and/or a fibre bundle for transmitting the probe light and/or the reflected light from the object surface.
- 15 116. A scanner according to any of claims 112 to 115, wherein the probe is detachable from the housing.
117. A scanner according to any of claims 112 to 116, wherein the probe is rigid or flexible.
- 20 118. A scanner according to any of claims 112 to 117, wherein the point of emission of probe light and the point of accumulation of reflected light is located on the probe.
- 25 119. A scanner according to any of claims 112 to 118, wherein a first point of emission of probe light and a first point of accumulation of reflected light is located on the probe, and a second point of emission of probe light and a second point of accumulation of reflected light is located on the housing.
- 30 120. A scanner according to any of claims 112 to 119, wherein the probe light is directed toward the object in a direction substantially parallel with the optical axis and/or the longitudinal axis of the probe.

121. A scanner according to any of claims 112 to 120, wherein the probe comprises a posterior reflective element, such as a mirror, or prism, for directing the probe light in a direction different from the optical axis, preferably in a direction perpendicular to the probe axis.
- 5
122. A scanner according to the previous claim, further comprising means for rotating the reflective element, preferably around an axis substantially parallel with the optical axis.
- 10
123. A scanner according to any of claims 112 to 122, wherein the probe is adapted to provide scan 360° around the optical axis and/or the longitudinal axis of the probe, preferably without rotation of probe and/or scanner.
- 15
124. A scanner according to any of claims 112 to 123, wherein a plurality of different probes matches the housing.
125. A scanner according to any of claims 112 to 124, comprising a first probe being adapted to scan the interior part of a human ear and a second probe being adapted to scan the exterior part of said human ear.
- 20
126. A scanner according to any of claims 112 to 125, wherein the housing is adapted to perform a 3D surface scan.
127. A scanner according to any of claims 112 to 126, wherein the housing with the probe attached is adapted to scan the interior part of a human ear and the housing with the probe detached is adapted to scan the exterior part of said human ear.
- 25
128. A scanner according to any of claims 112 to 127, further comprising means for merging and/or combining 3D data for the interior and exterior part of the ear, thereby providing a full 3D model of a human ear.
- 30
129. A scanner according to any of the preceding claims, being adapted to impression scanning, such as scanning of dental impressions and/or ear channel

impressions.

- 5 130. A scanner according to any of the preceding claims, being adapted to intraoral scanning, i.e. direct scanning of teeth and surrounding soft-tissue in the oral cavity.
- 10 131. A scanner according to any of the preceding claims, being adapted for dental applications, such as scanning of dental impressions, gypsum models, wax bites, dental prosthetics and abutments.
- 15 132. A scanner according to any of the preceding claims, being adapted to scanning of the 3D structure of skin in dermatological or cosmetological applications.
- 20 133. A scanner according to any of the preceding claims, being adapted to scanning of jewelry or wax models of whole jewelry or part of jewelry.
- 25 134. A scanner according to any of the preceding claims, being adapted to scanning and/or quality control of industrial parts
- 30 135. A scanner according to any of the preceding claims, being adapted to provide time resolved 3D scanning, such as time resolved 3D scanning of moving industrial parts.
- 35 136. A scanner according to any of the preceding claims, wherein the scanner is adapted to be handheld, and where the scanner comprises one or more built-in motion sensors that yield data for combining at least two partial scans to a 3D model of the surface of an object, where the motion sensor data potentially is used as a first guess for an optimal combination found by software.
137. A scanner according to any of the preceding claims, wherein the scanner is adapted to be handheld and where the scanner comprises one or more built-in motion sensors which yield data for interacting with the user interface of some software related to the scanning process.

5

138. A method for obtaining and/or measuring the 3D geometry of at least a part of the surface of an object, said method comprising the steps of:

- generating a probe light incorporating a spatial pattern,
- transmitting the probe light towards the object along the optical axis of an optical system, thereby illuminating at least a part of the object with said pattern,
- transmitting at least a part of the light returned from the object to the camera,
- varying the position of the focus plane of the pattern on the object while maintaining a fixed spatial relation of the scanner and the object,
- obtaining at least one image from said array of sensor elements,
- evaluating a correlation measure at each focus plane position between at least one image pixel and a weight function, where the weight function is determined based on information of the configuration of the spatial pattern;
- determining by analysis of the correlation measure the in-focus position(s) of:
 - each of a plurality of image pixels in the camera for said range of focus plane positions, or
 - each of a plurality of groups of image pixels in the camera for said range of focus planes, and
- transforming in-focus data into 3D real world coordinates.

30

139. A computer program product comprising program code means for causing a data processing system to perform the method of the preceding claim, when said program code means are executed on the data processing system.

140. A computer program product according to the previous claim, comprising a computer-readable medium having stored thereon the program code means.

5 141. A scanner for obtaining and/or measuring the 3D geometry of at least a part of the surface of an object, said scanner comprising:

- at least one camera accommodating an array of sensor elements,
- means for generating a probe light,
- means for transmitting the probe light towards the object thereby illuminating at least a part of the object,
- 10 - means for transmitting light returned from the object to the camera,
- means for varying the position of the focus plane on the object,
- means for obtaining at least one image from said array of sensor elements,
- 15 - means for:
 - a) determining the in-focus position(s) of:
 - each of a plurality of the sensor elements for a range of focus plane positions, or
 - each of a plurality of groups of the sensor elements for a range of focus plane positions, and
 - 20 b) transforming in-focus data into 3D real world coordinates;

wherein the scanner further comprises counter-weight means for counter-balancing the means for varying the position of the focus plane.

25 142. A method for obtaining and/or measuring the 3D geometry of at least a part of the surface of an object, said method comprising the steps of:

- accommodating an array of sensor elements,
- generating a probe light,
- transmitting the probe light towards the object thereby illuminating at least a part of the object,
- 30 - transmitting light returned from the object to the camera,
- varying the position of the focus plane on the object,
- obtaining at least one image from said array of sensor elements,
- determining the in-focus position(s) of:

- each of a plurality of the sensor elements for a range of focus plane positions, or
 - each of a plurality of groups of the sensor elements for a range of focus plane positions, and
- 5 - transforming in-focus data into 3D real world coordinates;
- wherein the method further comprises counter-balancing the means for varying the position of the focus plane.

10 143. A handheld 3D scanner with a grip at an angle of more than 30 degrees from the scanner's main optical axis, for use in intraoral or in-ear scanning.

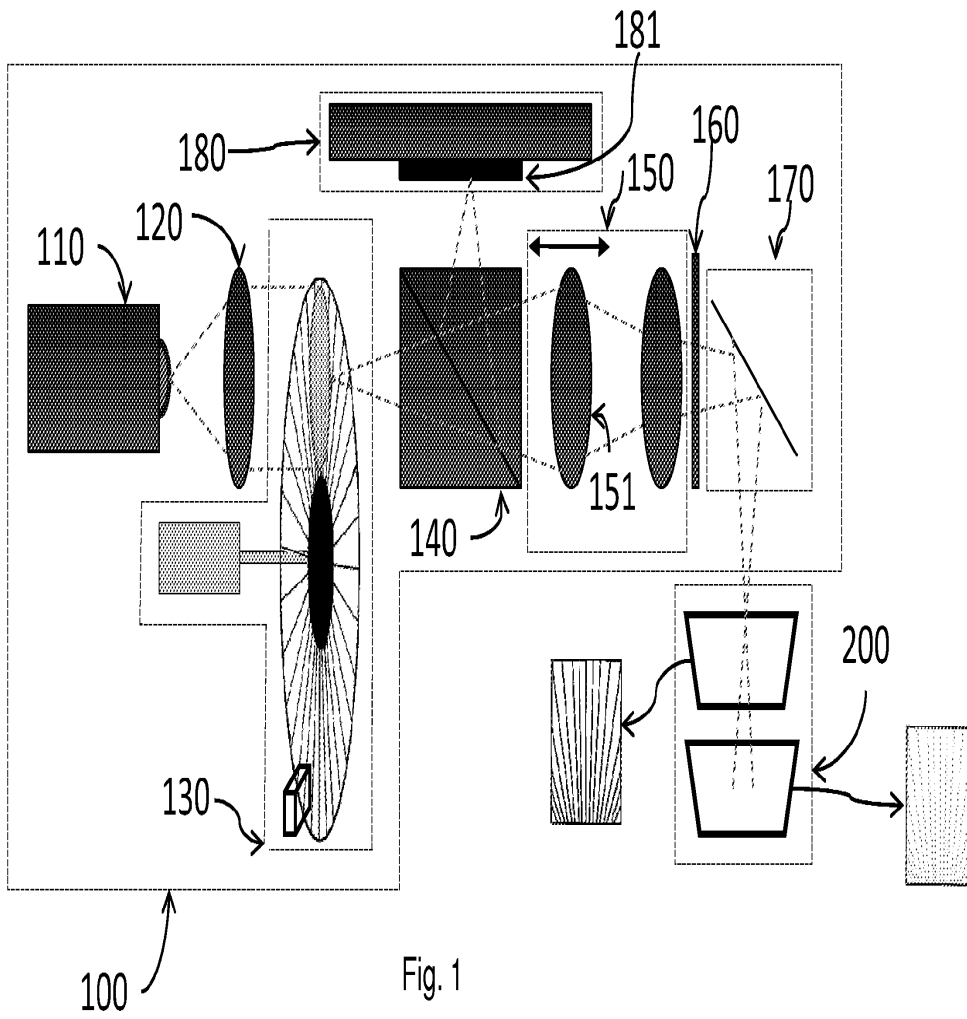

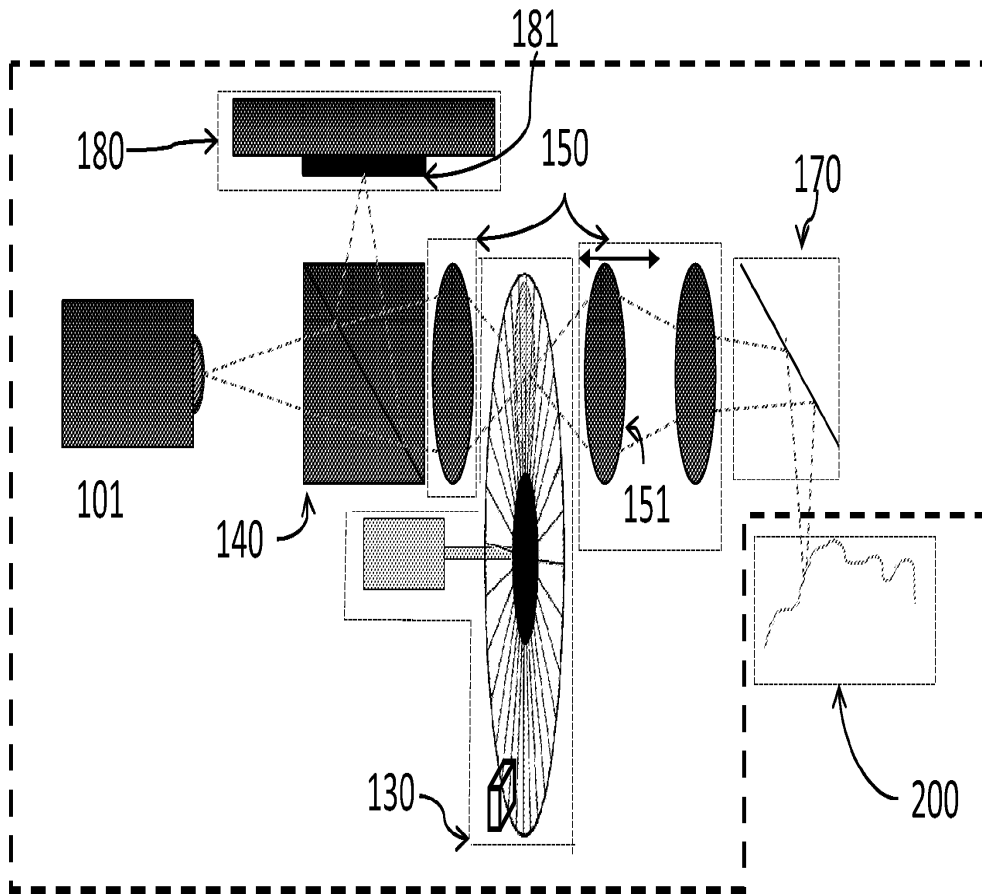
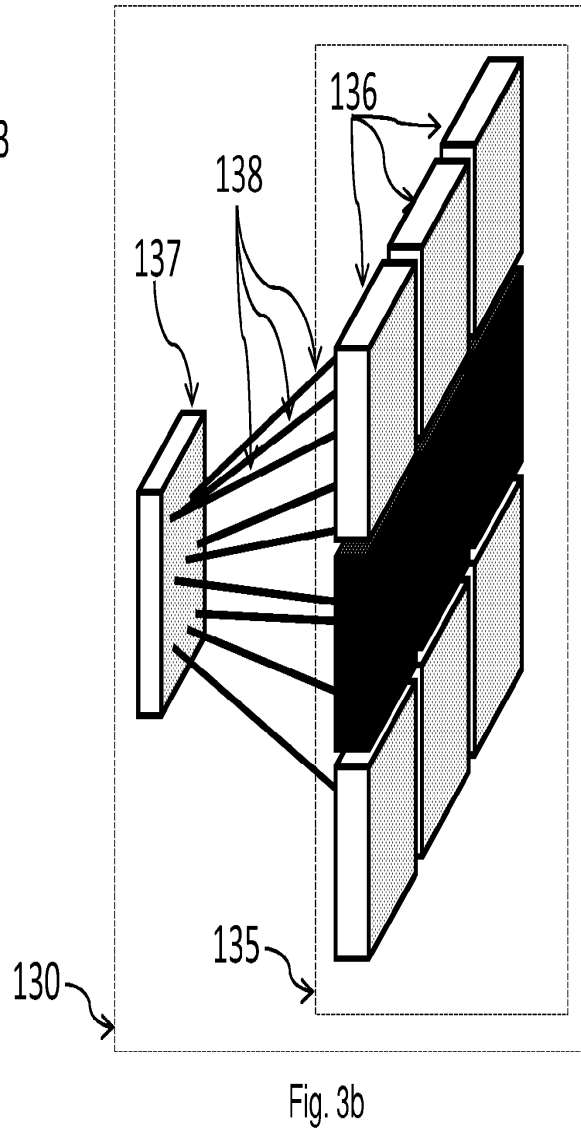
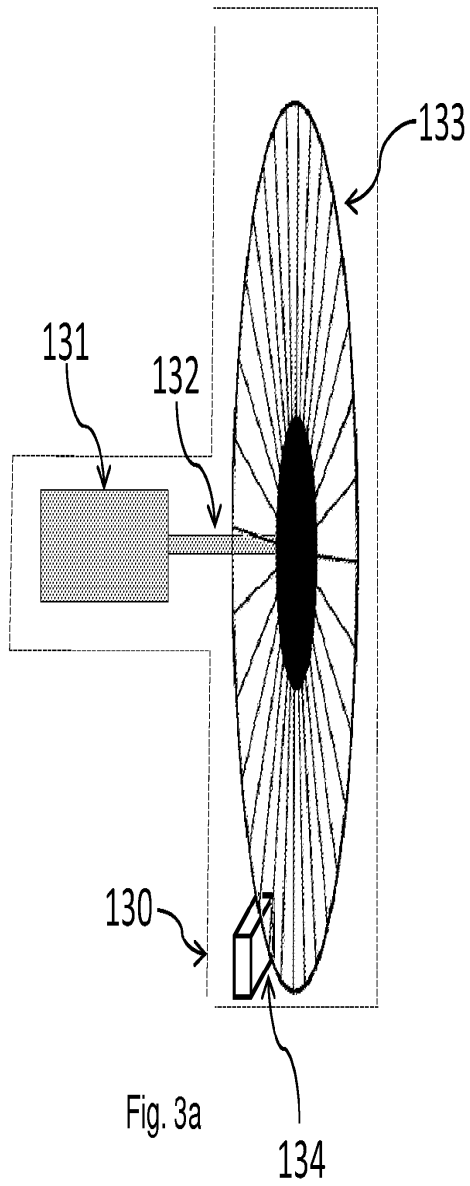

Fig. 2



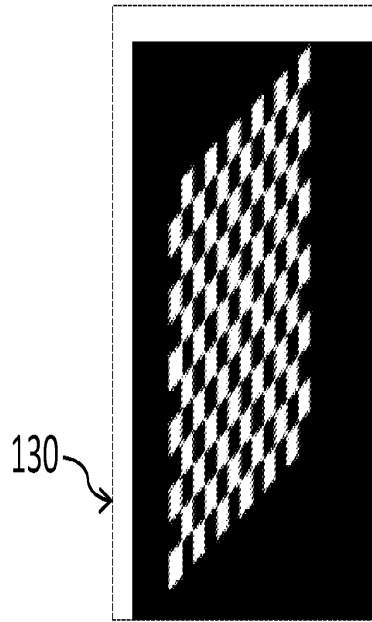

Fig. 3c

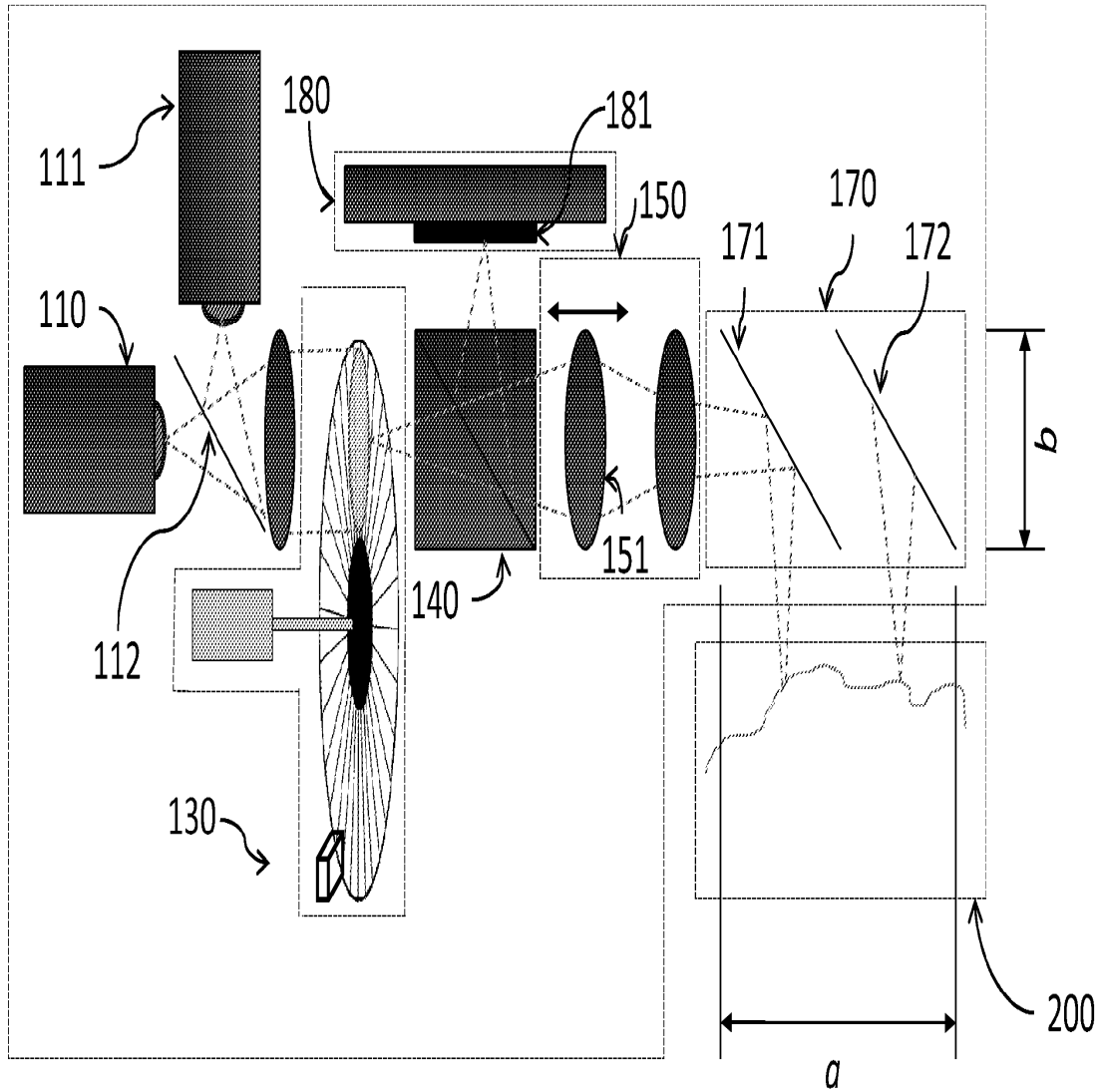

Fig. 4

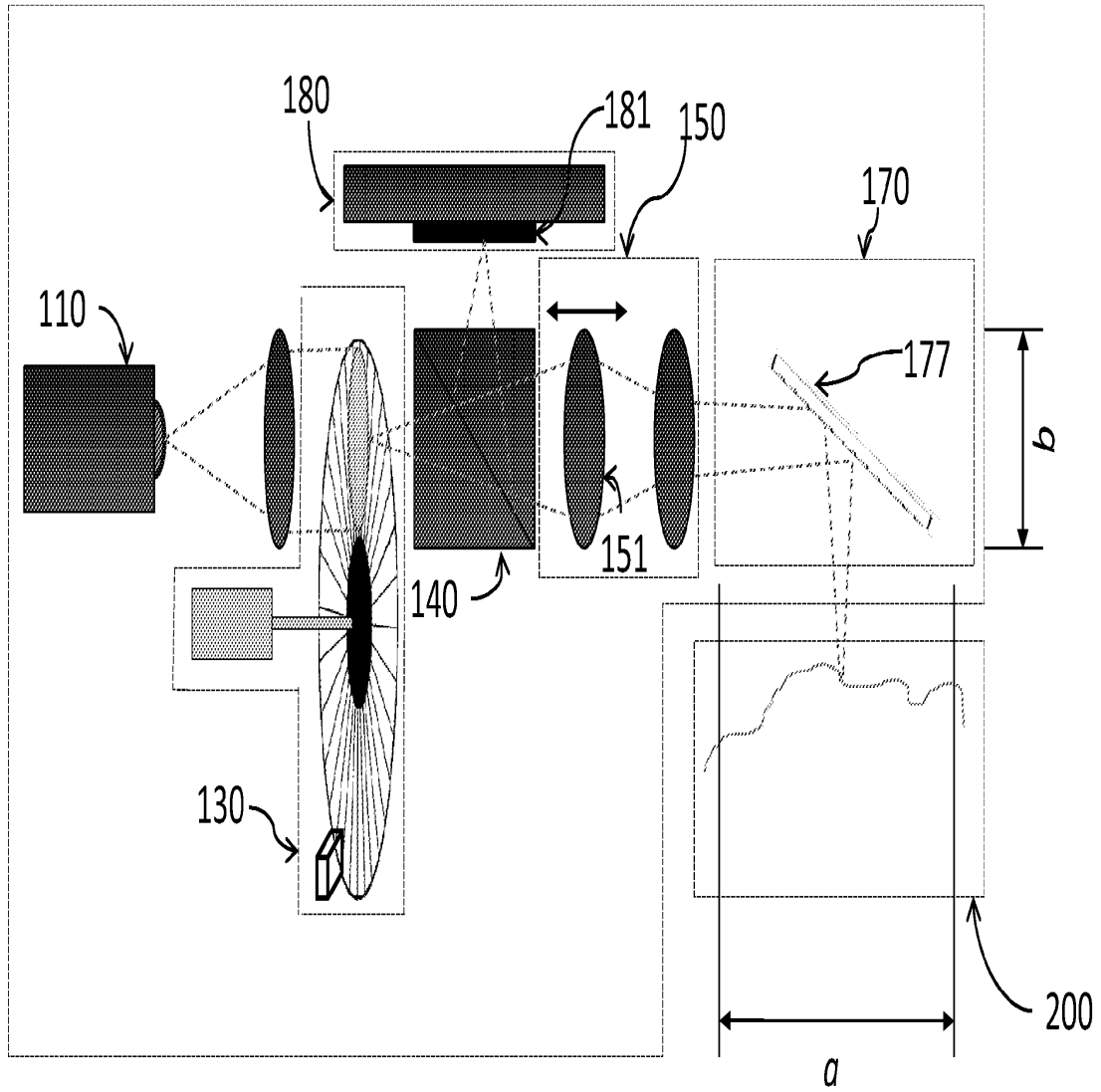

Fig. 7

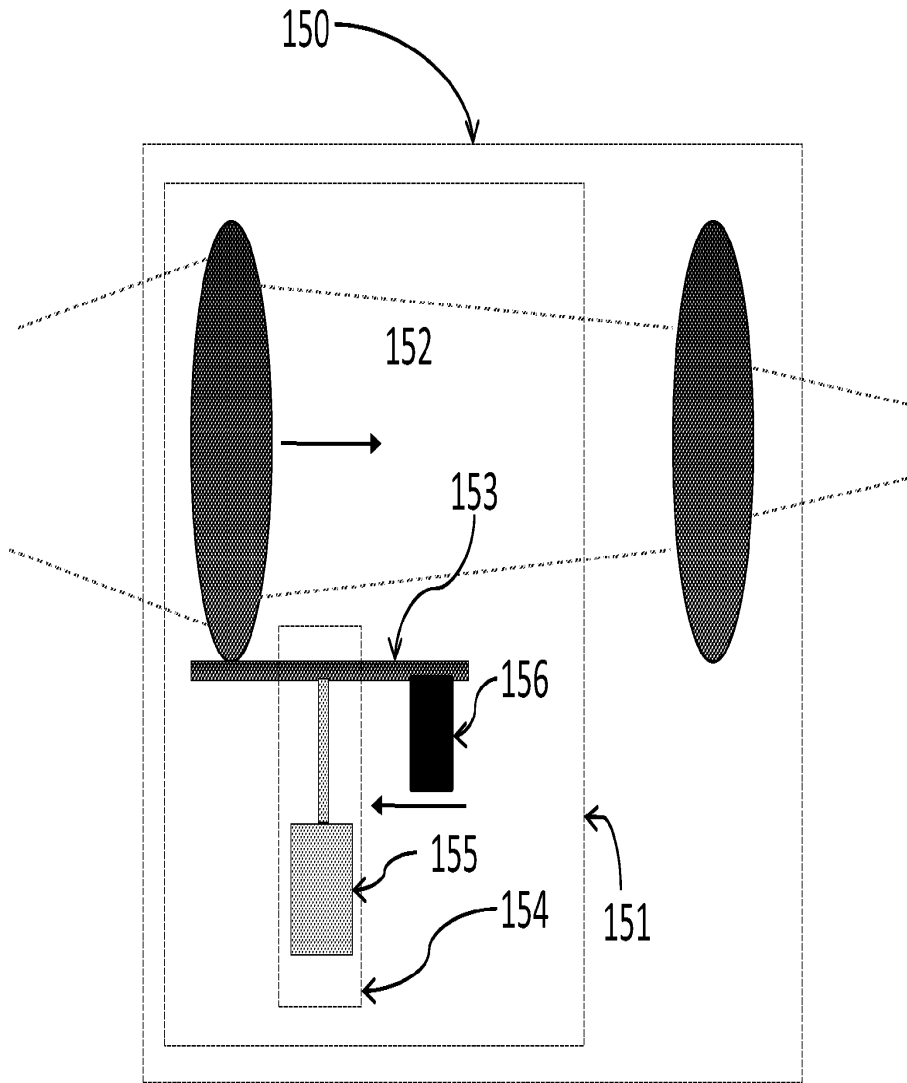

Fig. 8

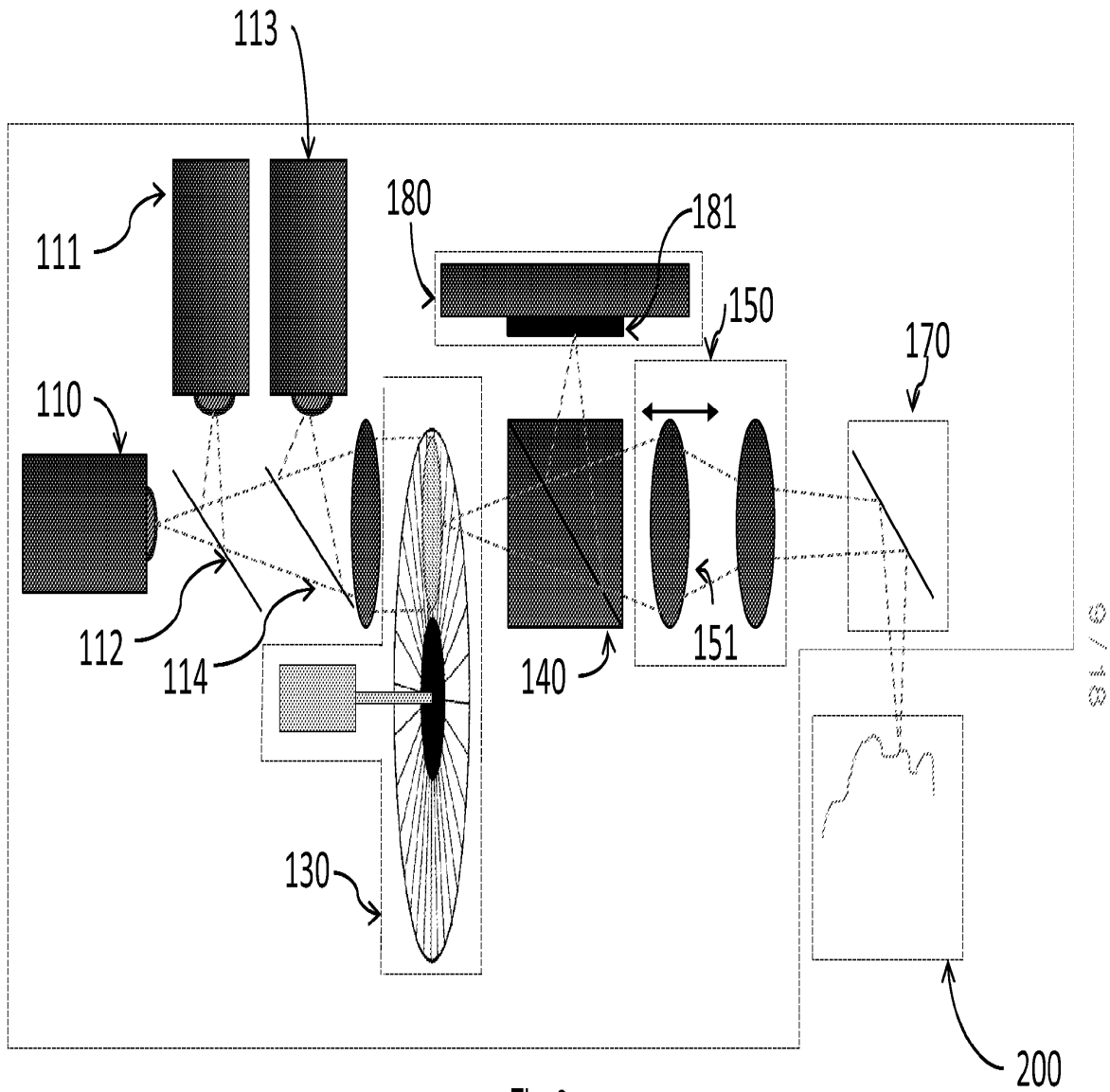

Fig. 9

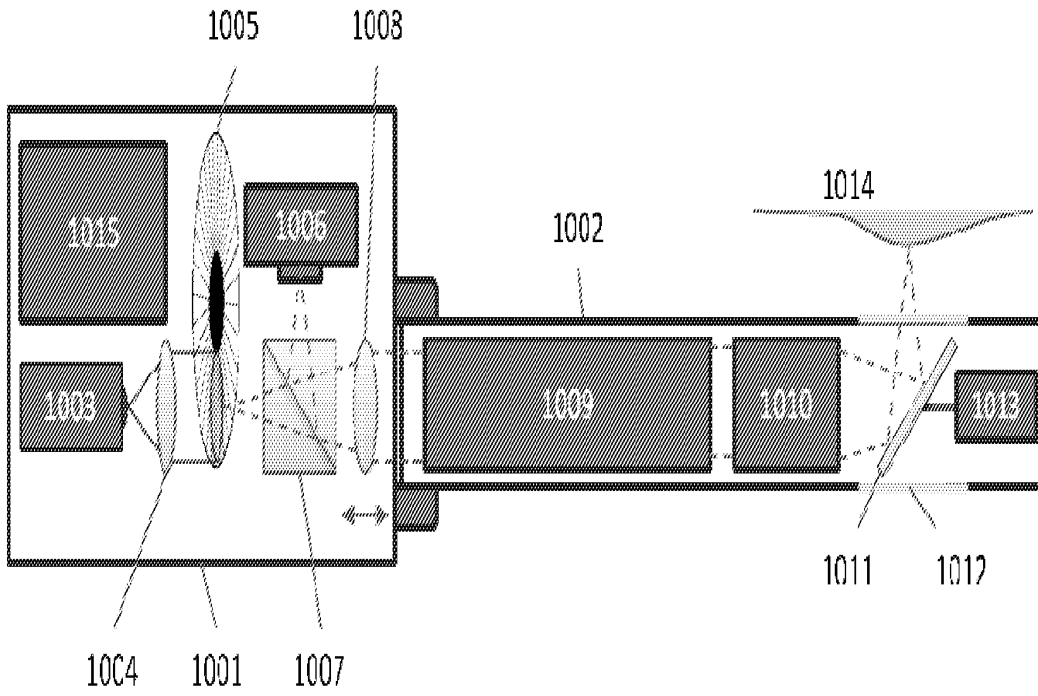

Fig. 12

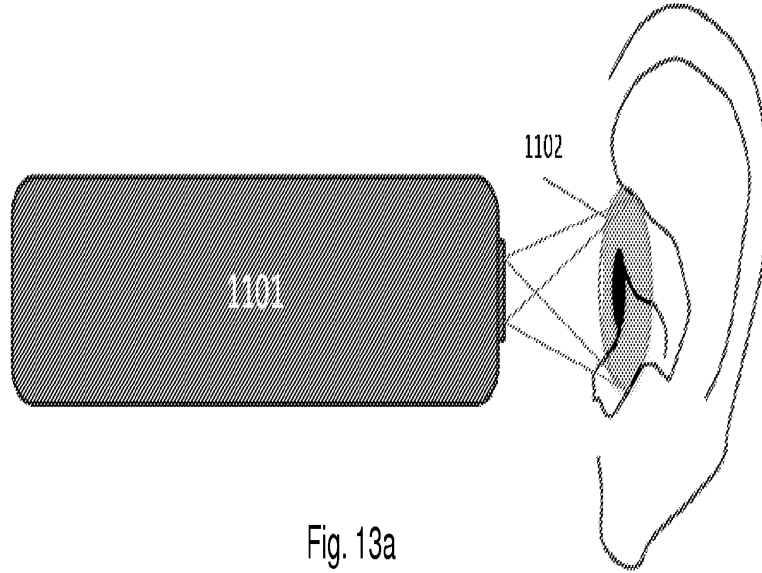

Fig. 13a

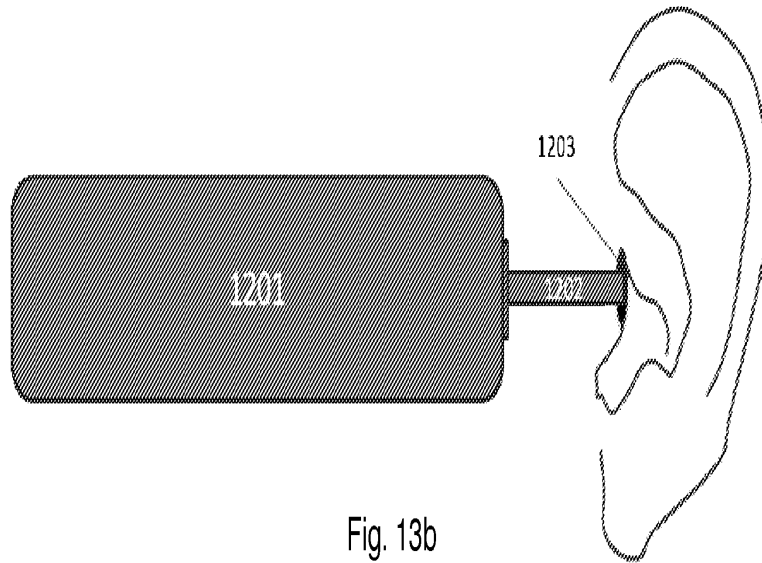

Fig. 13b

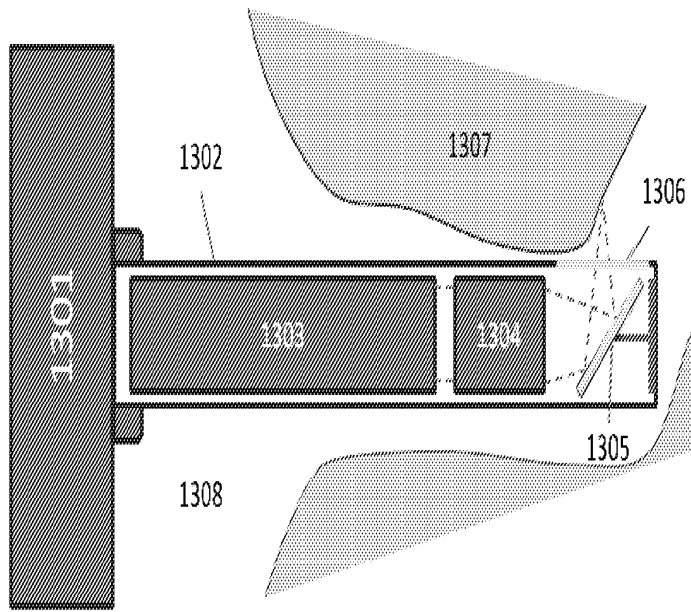

Fig. 14

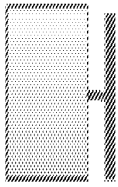

Fig. 15a

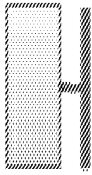

Fig. 15b

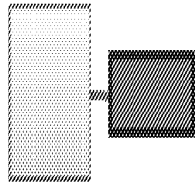
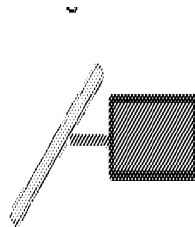

Fig. 15c

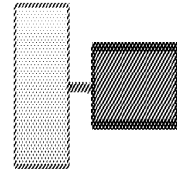
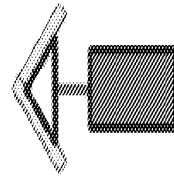

Fig. 15d

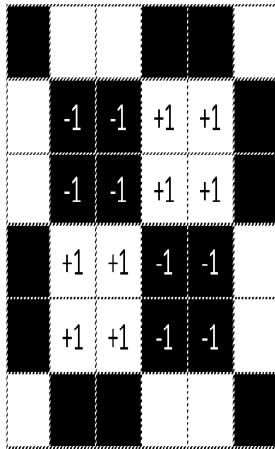

Fig. 16

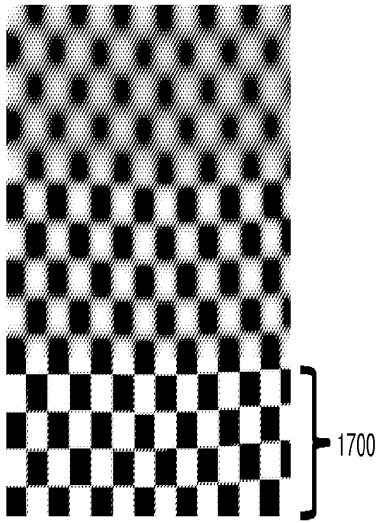

Fig. 17a

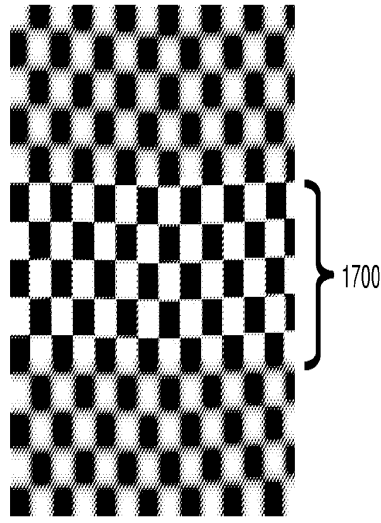

Fig. 17b

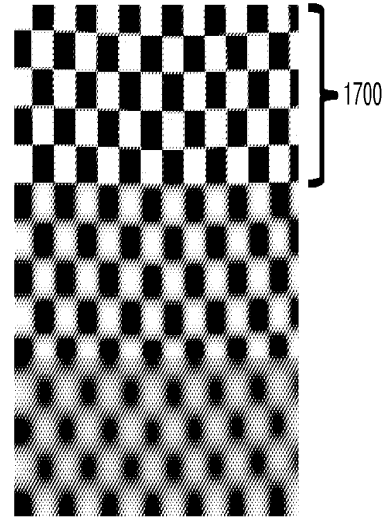

Fig. 17c

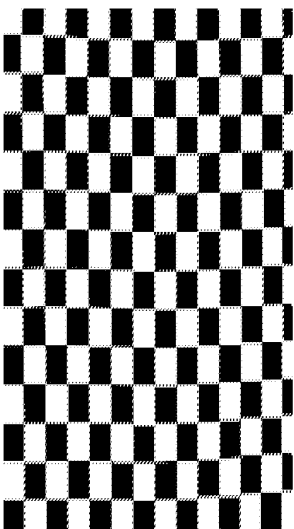

Fig. 17d

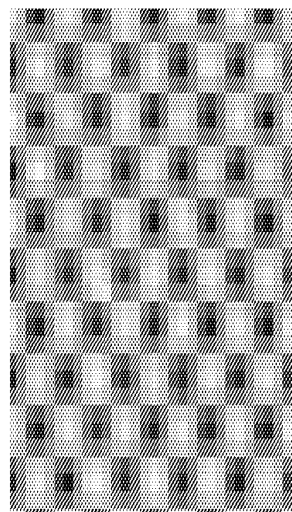
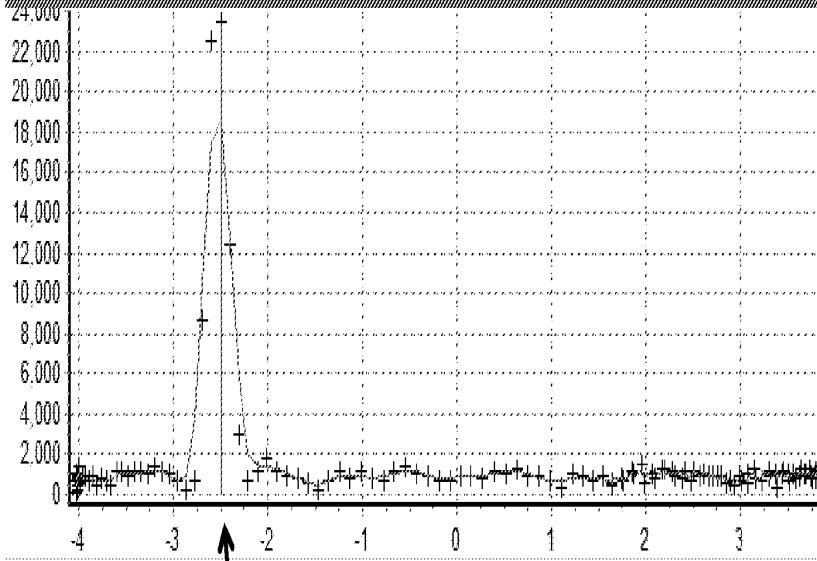
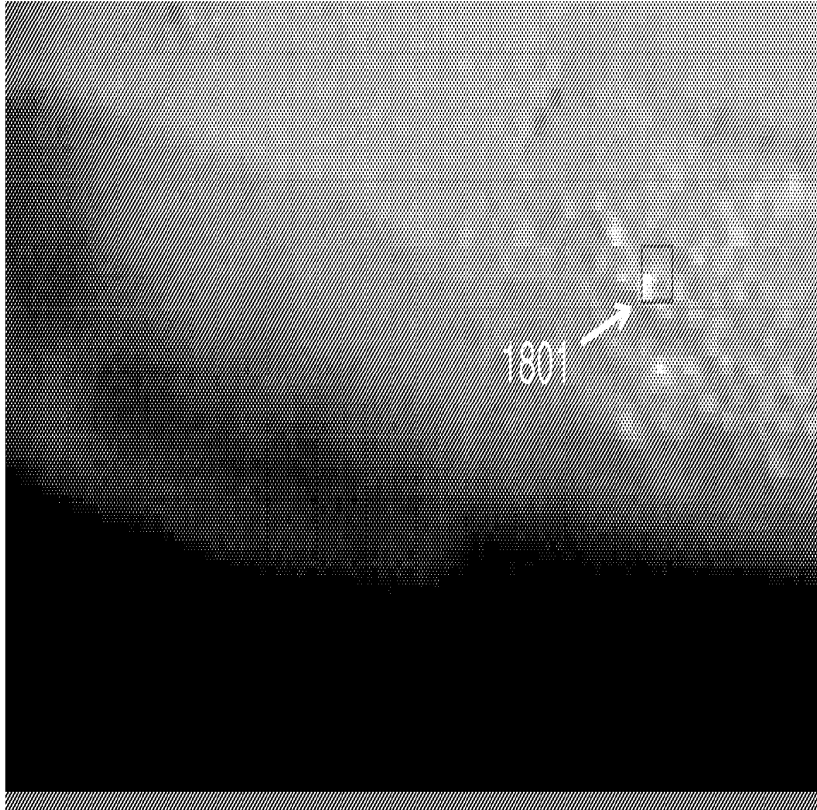

Fig. 17e



1802

Fig. 18



Fig. 19

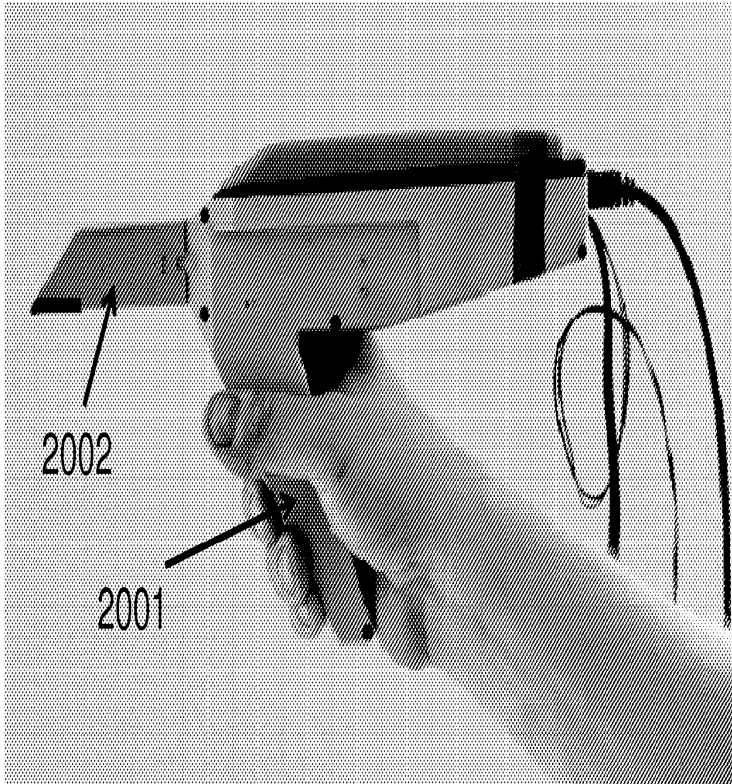

Fig. 20

INTERNATIONAL SEARCH REPORT

International application No
PCT/DK2010/050148

A. CLASSIFICATION OF SUBJECT MATTER INV. A61B5/107 ADD.		
According to International Patent Classification (IPC) or to both national classification and IPC		
B. FIELDS SEARCHED		
Minimum documentation searched (classification system followed by classification symbols) A61B		
Documentation searched other than minimum documentation to the extent that such documents are included in the fields searched		
Electronic data base consulted during the international search (name of data base and, where practical, search terms used) EPO-Internal		
C. DOCUMENTS CONSIDERED TO BE RELEVANT		
Category*	Citation of document, with indication, where appropriate, of the relevant passages	Relevant to claim No.
X A A A	US 4 575 805 A (MOERMANN WERNER H [CH] ET AL) 11 March 1986 (1986-03-11) column 2, line 23 - line 52 column 3, line 50 - line 68; figure 5 ----- US 2007/194214 A1 (PFEIFFER JOACHIM [DE]) 23 August 2007 (2007-08-23) paragraphs [0001], [0002], [0045], [0051], [0056], [0057], [0075] ----- US 2003/096210 A1 (RUBBERT RUDGER [DE] ET AL RUBBERT RUEDGER [DE] ET AL) 22 May 2003 (2003-05-22) paragraphs [0066], [0067] ----- -/--	143 1 1 1
<input checked="" type="checkbox"/> Further documents are listed in the continuation of Box C. <input checked="" type="checkbox"/> See patent family annex.		
* Special categories of cited documents :		
A document defining the general state of the art which is not considered to be of particular relevance *E* earlier document but published on or after the international filing date *L* document which may throw doubts on priority claim(s) or which is cited to establish the publication date of another citation or other special reason (as specified) *O* document referring to an oral disclosure, use, exhibition or other means *P* document published prior to the international filing date but later than the priority date claimed	*T* later document published after the international filing date or priority date and not in conflict with the application but cited to understand the principle or theory underlying the invention *X* document of particular relevance; the claimed invention cannot be considered novel or cannot be considered to involve an inventive step when the document is taken alone *Y* document of particular relevance; the claimed invention cannot be considered to involve an inventive step when the document is combined with one or more other such documents, such combination being obvious to a person skilled in the art. *&* document member of the same patent family	
Date of the actual completion of the international search 29 September 2010	Date of mailing of the international search report 06/10/2010	
Name and mailing address of the ISA/ European Patent Office, P.B. 5818 Patentlaan 2 NL - 2280 HV Rijswijk Tel. (+31-70) 340-2040, Fax: (+31-70) 340-3016	Authorized officer Hunt, Brynley	

INTERNATIONAL SEARCH REPORT

International application No
PCT/DK2010/050148

C(Continuation). DOCUMENTS CONSIDERED TO BE RELEVANT		
Category*	Citation of document, with indication, where appropriate, of the relevant passages	Relevant to claim No.
A	US 2006/158665 A1 (BABAYOFF NOAM [IL] ET AL) 20 July 2006 (2006-07-20) paragraphs [0035] - [0037], [0047]; figures 1a,3 -----	1,138, 141,142
A	US 2005/283065 A1 (BABAYOFF NOAM [IL]) 22 December 2005 (2005-12-22) the whole document -----	1,138, 141,142

INTERNATIONAL SEARCH REPORT

Information on patent family members

International application No
PCT/DK2010/050148

Patent document cited in search report	Publication date	Patent family member(s)	Publication date
US 4575805	A	11-03-1986	NONE
US 2007194214	A1	23-08-2007	AT 373834 T 15-10-2007 CN 1934481 A 21-03-2007 DE 102004014048 A1 20-10-2005 EP 1728115 A1 06-12-2006 WO 2005091046 A1 29-09-2005 JP 2007529731 T 25-10-2007
US 2003096210	A1	22-05-2003	US 2006079981 A1 13-04-2006 US 2009291417 A1 26-11-2009
US 2006158665	A1	20-07-2006	NONE
US 2005283065	A1	22-12-2005	AT 406850 T 15-09-2008 AT 383817 T 15-02-2008 DE 602005004332 T2 08-01-2009 EP 1607064 A2 21-12-2005 EP 1607041 A2 21-12-2005

(12) INTERNATIONAL APPLICATION PUBLISHED UNDER THE PATENT COOPERATION TREATY (PCT)

(19) World Intellectual Property
Organization
International Bureau



(10) International Publication Number
WO 2012/083967 A1

(43) International Publication Date
28 June 2012 (28.06.2012)

- (51) **International Patent Classification:**
A61C 13/00 (2006.01) A61B 5/107 (2006.01)
- (21) **International Application Number:**
PCT/DK2011/050507
- (22) **International Filing Date:**
21 December 2011 (21.12.2011)
- (25) **Filing Language:** English
- (26) **Publication Language:** English
- (30) **Priority Data:**
PA 2010 01171 21 December 2010 (21.12.2010) DK
61/426,057 22 December 2010 (22.12.2010) US
- (71) **Applicant (for all designated States except US):** 3SHAPE A/S [DK/DK]; Holmens Kanal 7, 4. sal, DK-1060 Copenhagen K (DK).
- (72) **Inventors; and**
- (75) **Inventors/Applicants (for US only):** FISKER, Rune [DK/DK]; Kaplevej 87, DK-2830 Virum (DK). VAN DER POEL, Mike [NL/DK]; Rævebakkevej 35B, DK-2610 Rødovre (DK).
- (74) **Agent:** MÜNZER, Marc; Guardian IP Consulting I/S, Diplomvej, Building 381, DK-2800 Kgs. Lyngby (DK).

(81) **Designated States (unless otherwise indicated, for every kind of national protection available):** AE, AG, AL, AM, AO, AT, AU, AZ, BA, BB, BG, BH, BR, BW, BY, BZ, CA, CH, CL, CN, CO, CR, CU, CZ, DE, DK, DM, DO, DZ, EC, EE, EG, ES, FI, GB, GD, GE, GH, GM, GT, HN, HR, HU, ID, IL, IN, IS, JP, KE, KG, KM, KN, KP, KR, KZ, LA, LC, LK, LR, LS, LT, LU, LY, MA, MD, ME, MG, MK, MN, MW, MX, MY, MZ, NA, NG, NI, NO, NZ, OM, PE, PG, PH, PL, PT, QA, RO, RS, RU, RW, SC, SD, SE, SG, SK, SL, SM, ST, SV, SY, TH, TJ, TM, TN, TR, TT, TZ, UA, UG, US, UZ, VC, VN, ZA, ZM, ZW.

(84) **Designated States (unless otherwise indicated, for every kind of regional protection available):** ARIPO (BW, GH, GM, KE, LR, LS, MW, MZ, NA, RW, SD, SL, SZ, TZ, UG, ZM, ZW), Eurasian (AM, AZ, BY, KG, KZ, MD, RU, TJ, TM), European (AL, AT, BE, BG, CH, CY, CZ, DE, DK, EE, ES, FI, FR, GB, GR, HR, HU, IE, IS, IT, LT, LU, LV, MC, MK, MT, NL, NO, PL, PT, RO, RS, SE, SI, SK, SM, TR), OAPI (BF, BJ, CF, CG, CI, CM, GA, GN, GQ, GW, ML, MR, NE, SN, TD, TG).

Published:

— with international search report (Art. 21(3))

(54) **Title:** Optical system in 3D focus scanner

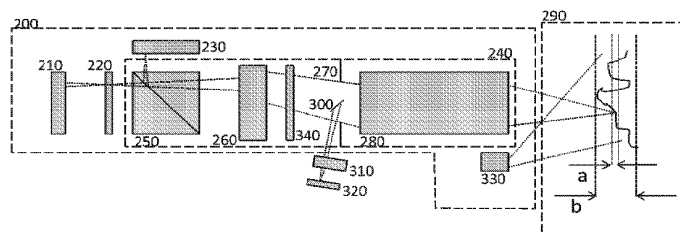

Fig. 3

(57) **Abstract:** Disclosed is a scanner (200) for obtaining and/or measuring a 3D geometry of at least a part of a surface of an object (290), said scanner comprising: - a first camera (230) comprising an array of sensor elements, - a first means (210) for generating a probe light, - means (240) for transmitting the probe light rays towards the object thereby illuminating at least a part of the object (290), - means (240) for transmitting light rays returned from the object to the array of sensor elements, - a first optical system (240) for imaging with a first depth of field on the first camera (230) at least part of the transmitted light rays returned from the object to the array of sensor elements, - means for varying the position of the focus plane on the object, - means (310) for obtaining at least one image from said array of sensor elements, - means for determining the in-focus position(s) of: - each of a plurality of the sensor elements for a range of focus plane positions, or - each of a plurality of groups of the sensor elements for a range of focus plane positions, and - means for transforming the in-focus data into 3D coordinates.

WO 2012/083967 A1

Optical system in 3D focus scanner

This invention generally relates to a 3D focus scanner. More particularly, the invention relates to an optical system in a 3D focus scanner.

5

Disclosed is a scanner for obtaining and/or measuring a 3D geometry of at least a part of a surface of an object, said scanner comprising:

- a first camera comprising an array of sensor elements,
- a first means for generating a probe light,
- 10 - means for transmitting the probe light rays towards the object thereby illuminating at least a part of the object,
- means for transmitting light rays returned from the object to the array of sensor elements,
- a first optical system for imaging with a first depth of field on the first camera
- 15 at least part of the transmitted light rays returned from the object to the array of sensor elements,
- means for varying the position of the focus plane on the object,
- means for obtaining at least one image from said array of sensor elements,
- means for determining the in-focus position(s) of:
- 20 - each of a plurality of the sensor elements for a range of focus plane positions, or
- each of a plurality of groups of the sensor elements for a range of focus plane positions, and
- means for transforming the in-focus data into 3D coordinates.

25

According to an aspect of the focus scanning apparatus, is disclosed a scanner for obtaining and/or measuring a 3D geometry of at least a part of a surface of an object, said scanner comprising:

- a first camera comprising an array of sensor elements,
- 30 - a first means for generating a probe light,

- means for transmitting the probe light rays towards the object thereby illuminating at least a part of the object,
- means for transmitting light rays returned from the object to the array of sensor elements,
- 5 - a first optical system for imaging with a first depth of field on the first camera at least part of the transmitted light rays returned from the object to the array of sensor elements,
 - means for varying the position of the focus plane on the object,
 - means for obtaining at least one image from said array of sensor elements,
 - 10 - means for determining the in-focus position(s) of:
 - each of a plurality of the sensor elements for a range of focus plane positions, or
 - each of a plurality of groups of the sensor elements for a range of focus plane positions, and
- 15 - means for transforming the in-focus data into 3D coordinates;
- means for selecting a portion of light rays returned from the object, where the light rays have been transmitted through at least a part of the first optical system; and
- a second camera for capturing at least some of the selected light rays with
- 20 a second depth of field which is substantially larger than the first depth of field.

In some embodiments, the second camera is configured for obtaining images
25 with a second depth of field. In some embodiments, the scanner comprises optical components arranged to image at least part of the selected portion of the light rays returned from the object onto the second camera with a second depth of field.

30 In some embodiments, the in-focus position of a sensor element corresponds to the position of the focus plane in which the focus plane intersects a portion

of the object surface and where the light rays returning from this portion of the object surface are imaged onto this particular sensor element. In embodiments, where a pattern is arranged to provide structure to the probe light, the in-focus position for a given sensor element may correspond to the position of the focus plane where the pattern is in focus on the object being scanned for this sensor element. The first camera may record a high value of the correlation measure for that sensor element at the in-focus position, when the position of the focus plane is varied over a range of values.

5
10 In some embodiments, the first depth of field is in the range of about 5 μm to about 1000 μm , such as in the range of about 10 μm to about 500 μm , such as in the range of about 50 μm to about 250 μm , such as in the range of about 75 μm to about 150 μm ,

15 In some embodiments, the second depth of field is in the range of about 1 mm to about 150 mm, such as in the range of about 3 mm to about 100 mm, such as in the range of about 5 mm to about 50 mm, such as in the range of about 10 mm to about 30 mm, such as in the range of about 15 mm to about 25 mm.

20

In some embodiments, the depth of the scan volume of the scanner as measured from the scanner is in the range of about 3 mm to about 100 mm, such as in the range of about 5 mm to about 50 mm, such as in the range of about 10 mm to about 30 mm, such as in the range of about 15 mm to about 25 mm,

25

In some embodiments, the ratio between the second depth of field and the depth of the scan volume of the scanner is in the range of about 0.1 to about 10, such as in the range of about 0.2 to about 5, such as in the range of about 0.25 to about 4, such as in the range of about 0.4 to about 2.5, such as in the range of about 0.5 to about 2, such as in the range of about 0.7 to

30

about 1.5, such as in the range of about 0.8 to about 1.25, such as in the range of about 0.9 to about 1.1.

5 In some embodiments, the ratio between the second depth of field and the first depth of field is in the range of about 10 to about 2000, such as in the range of about 25 to about 1000, such as in the range of about 50 to about 750, such as in the range of about 75 to about 500, such as in the range of about 100 to about 400, such as in the range of about 125 to about 300, such as in the range of about 150 to about 200.

10

In some embodiments, the means for transmitting light rays returned from the object to the array of sensor elements are the same as the means for transmitting the probe light rays towards the object. That is, the light rays returned from the object to the array of sensor elements are transmitted by the optical components that also are used for transmitting the probe light rays towards the object.

15

One advantage of a configuration where the light rays are transmitted to and from the object by the same optical components is that the number of optical components the system can be kept at a minimum, such that a more compact scanner can be realized.

20

In some embodiments, the means for transmitting the probe light rays towards the object and the means for transmitting the light rays returned from the object to the array of sensor elements are at least partly separate such that at least one or both of these means comprises an optical component it does not share with the other.

25

In some embodiments, the means for transmitting the probe light rays towards the object and the means for transmitting the light rays returned from the object to the array of sensor elements are separated such that each of

30

these means are made from optical components it does not share with the other.

One advantage of a configuration where at least some of the optical components used for transmitting the light rays to and from the object are different is that the light rays returning from the object can be manipulated in a different manner than light rays were manipulated on their way from the light source to the object. One filter may for instance be added in the means for transmitting the light rays returned from the object to the array of sensor elements and another filter in the means for transmitting the probe light rays towards the object.

In some embodiments, at a part of the means for transmitting the probe light rays towards the object and/or at a part of the means for transmitting light rays returned from the object to the array of sensor elements are at least partly separate from the first optical system.

In some embodiments, the means for transmitting the probe light rays towards the object and/or the means for transmitting light rays returned from the object to the array of sensor elements are integrated parts of the first optical system.

In some embodiments, the means for transmitting the probe light rays towards the object comprises an arrangement of optical components, such as lenses and mirrors, arranged for transmitting the probe light from the first light source towards the object.

In some embodiments, the means for transmitting light rays returned from the object to the array of sensor elements may comprise an arrangement of optical components, such as lenses and mirrors, arranged for transmitting the light rays returned from the object to the array of sensor elements.

In some embodiments, the first optical system comprises an arrangement of lenses for transmitting the probe light towards the object and for imaging with a first depth of field at least part of the transmitted light rays returned from the object onto the array of sensor elements. The probe light may be transmitted
5 onto the object along the same optical axis of the first optical system as the light rays returned from the object are transmitted along.

In the context of the present invention, the phrase "scanner" and "focus scanning apparatus" may be used interchangeably.

10

In some embodiments, the first camera consists of a charge-coupled device (CCD). In this case, the light rays may travel directly from the first optical system to the CCD without passing any further beam shaping optics.

15 In some embodiments, the first camera consists of a charge-coupled device (CCD) and at least one beam shaping optical component such as a filter or a lens.

The invention generally relates to three dimensional (3D) scanning of the surface geometry of objects. A focus scanning apparatus perform a non-contact 3D scanning of an object by obtaining a series of images for different focus planes on the object and determining in-focus regions for the obtained images. This is done by means of a camera comprising an array of sensor elements and imaging optics where the focus plane on the object can be varied. The in-focus data is transformed into 3D real world coordinates thereby obtaining a 3D surface or 3D model of the object. For the purpose of 3D scanning it is advantageous to obtain images with a shallow depth of field so that in-focus positions are determined with high accuracy.

25
30 In some embodiments, the focus scanning apparatus comprises a second camera used for obtaining an image with a large depth of field while obtaining

shallow depth of field images needed for the 3D scanning with the first camera in the apparatus. The large depth of field image may have such a large depth of field that all scanned parts of the object are in focus. The large depth of field image may also have the same perspective as the shallow
5 depth of field images.

It is an advantage of obtaining such a large depth of field image that the large depth of field image may be used as assistance when the scanner operator aims the scanner onto the object being scanned. In this case the large depth
10 of field image may be displayed on some display.

It is a further advantage that if the large depth of field image has a fixed perspective with respect to the shallow depth of field images, then there exists a correspondence between the 3D scanned surface and the large
15 depth of field image. This may be used to overlay texture obtained in the large depth of field image onto the 3D scanned surface constructed from in-focus data in the series of images obtained by means of the first camera.

Furthermore, it is an advantage that the large depth of field image can have a
20 larger field of view than the shallow depth of field images. This may assist in aiming the scanner properly for 3D scanning of a certain region.

Furthermore, it is an advantage that the large depth of field image can have a large frame rate, such as e.g. 30 fps or 60 fps. In a hand-held focus scanner
25 the high frame rate may be used for tracking the relative motion of the scanner and the object being scanned by analyzing the motion of feature points in the large depth of field images.

Furthermore, it is an advantage that the large depth of field image can be in
30 colors. This may allow for overlay of color texture onto the 3D scanned surface, such as by a registration of the color texture onto the 3D scanned

surface. A relation between the pixels of the images obtained by the first and the second camera can be provided by e.g. a calibration scanning of a calibration object or by precise alignment of the different parts of the scanner.

- 5 Furthermore, it is an advantage that a large depth of field image in color can be used for distinguishing different materials or surfaces on the object being scanned. Such a distinction can be useful in further treatment of the 3D data of the object.
- 10 Furthermore, for the purpose of 3D scanning it may be advantageous to use polarization optics to enhance specular reflections from the surface of the object being scanned. Such specular reflections, however, can contain highlights. The large depth of field image can be captured with polarizing optics to reduce specular reflections. For color measurements this may be particularly advantageous. Thus it becomes possible to obtain information of
- 15 the scanned object from light returned from the object where both specular reflections have been enhanced - for the 3D scanning - and where specular reflections have been inhibited - for the large depth of field image. Such polarization information can be advantageous to use in e.g. color analysis of
- 20 the object being scanned.

Furthermore, it is an advantage that the information in the large depth of field image can be used to distinguish different types of material and/or surfaces on the object being scanned. This is in particular true if the large depth of

25 field image contains color information.

Furthermore, it is an advantage that it is possible to perform a spectral analysis of the large depth of field image obtained by means of the second camera: This may be done by selecting a 1D portion of the light rays returned

30 from the object, such that the large depth of field image is 1D. In this case it becomes possible to use one axis of the 2D second camera as a spatial axis

and the other axis as a spectral axis. Such spectral analysis can be useful for detailed color measurement or determination of material composition in the surface.

In the context of the present invention, the phrase "1D portion" may refer to a portion with a width which is substantially smaller than its dimension along its longitudinal axis, such as about 100 times smaller, such as about 50 times smaller such as about 25 times smaller such as about 10 times smaller such as about 5 times smaller. In some embodiments the width of the 1D portion is smaller than about 5mm, such as smaller than about 2.5mm, such as smaller than about 1mm, such as smaller than about 0.5mm, such as smaller than about 0.25mm, such as smaller than about 0.1 mm.

The apparatus is particularly suited for intraoral scanning, i.e. direct scanning of teeth and surrounding soft-tissue in the oral cavity. Other dental related applications of the invention are for scanning dental impressions, gypsum models, wax bites, dental prosthetics and abutments.

The apparatus is also suited for scanning of the interior and exterior part of a human ear or of ear channel impressions.

The apparatus may also be used within scanning of the 3D structure of skin in dermatological or cosmetic / cosmetological applications, scanning of jewelry or wax models of whole jewelry or part of jewelry, scanning of industrial parts and even time resolved 3D scanning, such as time resolved 3D scanning of moving industrial parts.

Creating a large depth of field (DOF) image

In some embodiments the second camera is adapted for forming at least one image in 1D and/or 2D of at least some of the selected light rays.

In some embodiments the second depth of field image has a fixed perspective relative to the perspective of the first depth of field image(s).

5 In some embodiments the second depth of field image has substantially the same perspective as the first depth of field image(s).

In some embodiments the second depth of field image is substantially unaffected by varying the position of the focus plane on the object.

10 In some embodiments the means for selecting a portion of light rays returned from the object is arranged in an aperture in the first optical system.

In some embodiments the means for selecting a portion of light rays is arranged between the first optical system and focusing optics of the scanner.

15

In some embodiments the means for selecting a portion of light rays is arranged between the focusing optics of the scanner and the part of the scanner where light rays exit and/or enter the scanner.

20 In some embodiments the means for selecting a portion of light rays is a second optical element arranged in the aperture to select light rays from a region of the aperture for obtaining the second depth of field image(s).

In some embodiments the region of the aperture, where light rays is selected from, is small relative to the total area of the aperture, such as less than 50% of the area of the aperture, such as less than about 40% of the area of the aperture, such as less than about 30% of the area of the aperture, such as less than about 20% of the area of the aperture, such as less than about 10% of the area of the aperture, such as less than about 5% of the area of the aperture, such as less than about 2% of the area of the aperture, such as less than about 1% of the area of the aperture.

30

In some embodiments the selected light rays are deflected in a different direction than the direction of the first optical system.

5 In some embodiments the deflected rays are directed to a second optical system for imaging onto the second camera.

In some embodiments the first camera and the second camera are adapted to operate simultaneously.

10 In some embodiments the second optical element in the aperture is a mirror.

In some embodiments the second optical element in the aperture is a beam splitter.

15 In some embodiments the second optical element in the aperture is a filter adapted to select light rays of one or more specific wavelengths.

In some embodiments the second optical element in the aperture is small relative to the total area of the aperture, such as less than 50% of the area of the aperture, such as less than about 40% of the area of the aperture, such as less than about 30% of the area of the aperture, such as less than about 20% of the area of the aperture, such as less than about 10% of the area of the aperture, such as less than about 5% of the area of the aperture, such as less than about 2% of the area of the aperture, such as less than about 1% of the area of the aperture.

20

25

The size of the second optical element may be e.g. between 1% and 10% of the size of the aperture. The diameter of the second optical element may be e.g. 2-3 mm. Due to the small size of the second optical element, the second optical element will most likely not affect the focus scanning.

30

The image which is acquired with the second camera may correspond to what is captured with the first camera, i.e. the view, the perspective etc. may be the same for images acquired with both cameras. Because the optical elements function as a very small aperture, the depth of field of the second camera becomes very large, and thus everything in the images captured with the second camera may be in focus at the same time. The image acquired with the second camera may work as an assisting image for the operator of the scanner. Thus the depth of field is very small or shallow in the images obtained by the first camera for the focus scanning, and the depth of field is very large for the assisting image obtained by the second camera.

In some embodiments, the scanner comprises an aperture with an effective area over which effective area light rays returning from the object are allowed to pass through the aperture towards the first camera.

In some embodiments, the aperture is defined by a first optical element of the scanner, where the first optical element is capable of controlling the effective area of the aperture.

In some embodiments, the scanner comprises a first optical element arranged in said aperture in such a manner that the first optical element is capable of controlling the effective area of the aperture.

The first optical element may operate in combination with a separate aperture of the scanner or it may operate alone to define the aperture.

The first optical element may be capable of controlling the effective area of the aperture, such that the effective area can be changed between a relatively larger effective aperture area and a relatively smaller effective aperture area.

With the first optical element in a configuration corresponding to the relatively larger effective aperture area, at least part of the transmitted light rays returned from the object is imaged on the first camera with a first depth of field. With the first optical element in the configuration corresponding to the relatively smaller effective aperture area, at least part of the transmitted light rays returned from the object is imaged on the first camera with a second depth of field, where the second depth of field is larger than the first depth of field. I.e., switching between these two configurations of the first optical element provides that the first optical system can image onto the first camera the transmitted light rays returned from the object both with the first depth of field and with the second depth of field.

Embodiments of the scanner providing control over the size of the aperture can thus have the advantage that a single camera can be used for obtaining both the shallow depth of field images and the large depth of field images.

In some embodiments, the first optical element is configured for switching the effective area of the aperture between the relatively larger effective area and the relatively smaller effective area in such a manner that the ratio between the relatively larger effective area and the relatively smaller effective area may be in the range of about 1.2 to about 100, such as in range of about 1.4 to about 50, such as in range of about 1.7 to about 35, such as in range of about 2 to about 25, such as in range of about 2.5 to about 16, such as in range of about 2 to about 10, such as in range of about 3 to about 8.

In some embodiments the first optical element is configured to switch between selecting substantially all light rays impinging on the aperture and only selecting a portion of the light rays impinging the aperture.

The configuration of the first optical element corresponding to the relatively larger effective aperture area may be such that substantially all light rays

impinging on the aperture are allowed to pass through the aperture to the first camera.

The configuration of the first optical element corresponding to the relatively smaller effective aperture area may be such that only the selected portion of the light rays impinging the aperture are allowed to pass through the aperture
5 to the first camera.

In some embodiments the selected portion of light rays impinging on the aperture is small relative to all the light rays impinging the aperture, such as
10 less than 50% of all light rays, such as less than about 40% of all light rays, such as less than about 30% of all light rays, such as less than about 20% of all light rays, such as less than about 10% of all light rays, such as less than about 5% of all light rays, such as less than about 2% of all light rays, such as less than about 1% of all light rays.

15 In the context of the present invention, an optical element may be said to be arranged in the aperture when it is arranged in such a manner that at least part of the element is within a volume extending along the optical axis with a cross section defined by the aperture, i.e. by the opening of the aperture. At
20 least said part of the optical element is hence visible from both sides of the aperture when viewing the opening of the aperture along the optical axis.

When an optical element is arranged in the aperture at least a portion of the light rays returning from the object and propagating along the optical axis
25 may impinge on the optical element.

In some cases an optical element can be said to be arranged in the aperture if it will collide with the aperture when moved perpendicular to the optical axis. The extension of said volume from the aperture may then be
30 substantially zero.

In some cases an optical element can be said to be arranged in the aperture if said volume extends a distance from the aperture, such as a distance of less than about 10 mm from the aperture, such as less than about 8 mm from the aperture, such as less than about 5 mm from the aperture, such as less than about 3 mm from the aperture, such as less than about 2 mm from the aperture, such as less than about 1 mm from the aperture. The optical element may then be said to be arranged in the aperture even if it would stay clear of the aperture if moved perpendicular to the optical axis.

10 In some embodiments the first optical element configured to switch comprises a liquid crystal.

In some embodiments the first optical element and/or the second optical element is configured for controlling the polarization of the light rays.

15

Besides the different optical elements already mentioned, the first and/or second optical elements may be polarizers, lenses, gratings, retardation plates, glass with coatings, such as evaporated coatings or spotted coatings.

20 In some embodiments means for polarizing the light rays is arranged in front of the first means for generating a probe light and/or in front of the second camera. Thus polarization control can be provided. In some cases, it is an advantage to provide crossed polarizers in front of light source and second camera.

25

Color images and second light sources

In some embodiments the probe light is substantially white light and the first means for generating a probe light is a first light source configured for emitting white light, such as a white phosphorous InGaN LED or a supercontinuum light source.

30

In some embodiments the scanner comprises a second means for generating a probe light which is not used for determining the in-focus positions.

5 In some embodiments the second means for generating a probe light generates white light. The second means for generating a probe light may be a second light source configured for emitting white light, such as a white phosphorous InGaN LED or a supercontinuum light source

10 In some embodiments the second camera is a color camera.

In some embodiments the color camera comprises a 2D array of photo sensors and a color filter array.

15 In some embodiments the color filter array is a Bayer filter array.

In some embodiments the color filter array comprises more than three filters.

20 In some embodiments the color camera comprises a trichroic beam splitter and three different sensors to obtain images of the individual colors.

In some embodiments, the color of the probe light generated by the second means is adapted to be changed.

25 In some embodiments, the second means is capable of changing the color of the probe light it generates.

In some embodiments the second means for generating probe light is LEDs of different colors.

30 In some embodiments the differently colored LEDs are adapted to be activated at different times, and whereby black and white images are adapted

to be recorded with the second camera, and where the black and images are adapted to be combined to a full-color image.

5 The second camera can be arranged as close as possible to the aperture for reducing the distance the light rays must travel for hitting the sensors in the camera. However, the second camera can also be arranged in the end of the scanner pointing away from the object to be scanned, since this may allow for a more slender scanner.

10

Line spectral measurement

According to an aspect of the focus scanning apparatus, disclosed is a scanner for obtaining and/or measuring a 3D geometry of at least a part of a surface of an object, said scanner comprising:

- 15 - a first camera comprising an array of sensor elements,
- a first means for generating a probe light,
- means for transmitting the probe light rays towards the object thereby illuminating at least a part of the object,
- means for transmitting light rays returned from the object to the array of
20 sensor elements,
- a first optical system for imaging with a first depth of field on the first camera at least part of the transmitted light rays returned from the object to the array of sensor elements,
- means for varying the position of the focus plane on the object,
25 - means for obtaining at least one image from said array of sensor elements,
- means for determining the in-focus position(s) of:
- each of a plurality of the sensor elements for a range of focus plane positions, or
- each of a plurality of groups of the sensor elements
30 for a range of focus plane positions, and
- means for transforming the in-focus data into 3D coordinates;

wherein the scanner further comprises means for performing spectral analysis of the light returned from the object.

5 In some embodiments the means for performing spectral analysis is in a 1D array.

In some embodiments points or sections in the 1D image are spectrally analyzed.

10 In some embodiments the 1D spectral analysis is performed on the second camera comprising a 2D array, where one axis of the camera array corresponds to a spatial coordinate on the object being scanned and the other axis of the camera array corresponds to a wavelength coordinate of the light returned from the object.

15

In some embodiments, one dimension of the second camera is used as a spatial dimension while the other dimension of the second camera is used as a spectral dimension.

This may be achieved in the following way: a portion of the light rays returning from the object is selected by the second optical element and imaged onto a slit which selects a 1D portion of the 2D distribution of the light rays. The 1D portion is then projected onto a diffractive optical component, such as a grating, where the diffractive optical component is arranged to diffract each section of the 1D portion into a plane perpendicular to the long axis of the 1D portion. Additional optics may be arranged to guide the diffracted light rays onto the 2D array of sensor elements in the second camera such that different wavelengths of the light in one section is diffracted into a wavelength specific angle and hence onto a wavelength specific sensor element. There is hence a correlation between each sensor element in the array of sensor elements and the wavelength of light rays in a section of the selected 1D portion. From knowledge of this correlation, obtained e.g. by a previous

20
25
30

calibration of the scanner, a spectrum can be obtained for each section of the 1D portion. In this case the second light source may be a white-light source, and it is understood that the second light source can comprise collimation optics.

5

In some embodiments the spectrally analyzed light is a portion of light rays returned from the object and transmitted through at least a part of the first optical system. The scanner may comprise an element configured for selecting a portion of light rays returned from the object, such as a slit.

10

In some embodiments the spectral analysis is performed by means of a diffractive optical component.

In some embodiments the diffractive optical component is a grating.

15

In some embodiments the spectral analysis is performed by means of a prism.

In some embodiments the spectral analysis is performed by means of a color gradient film.

20

Combination of 3D focus scanner with a color measurement probe

A prior art color measuring probe is the probe disclosed in US5745299, which is a probe comprising a central light source and a number of receivers. The probe must be moved towards/away from the object to be color measured, e.g. a tooth, during the color measurement, because the probe cannot measure the 3D geometry of the object, and therefore redundancy is necessary for validating the color measurement.

30

However, in the present focus scanning apparatus, the color measurement can be obtained without having to move the color measuring probe towards/away from the object, because the 3D geometry of the object is known, the distance etc. between the light source(s) and the light sensor(s) is known, the surface which is color measured is known and the inclination/curvature of the surface is known.

5 Since the geometry is known, a geometrically conditional correction of the measured values can be performed and the color can be derived independently of the geometry.

10

In some embodiments, a color measuring probe is attached to the focus scanning apparatus in such a way that the color measuring probe can obtain data from one section of a scanned object while another section of the object can be 3D scanned by the focus scanning optics of the scanner. The color measuring probe may be configured for measuring the color of a surface it is brought into contact with and the color measuring probe may be attached to the focus scanning apparatus in such a manner that it can be brought into contact with an object while the focus scanning apparatus is still capable of scanning the object.

15 From knowledge of the optics of the focus scanning apparatus and the fixed relative position of the color measuring probe and the focus scanning apparatus a correlation between the color data obtained by the color measuring probe and the 3D coordinates obtained simultaneously by the focus scanning apparatus can be obtained. A registration of the color data into a 3D model of the object formed by e.g. triangulation of the obtained 3D coordinates can be provided based on this correlation.

25 The focus scanning apparatus and the color measuring probe may be calibrated, such that the color measurement can be correctly combined with/related to the 3D geometry of the object.

30

The color measuring probe may be a fiber probe, which is flexible and bendable.

5 The color measuring probe may perform a color measurement which allows for distinguishing between the teeth and the tissue in the mouth.

The color measuring probe may measure the color of different regions on a tooth, such that the original colors of the tooth can be reproduced in a restoration.

10 The color measurement may be used to determine the exact margin line on teeth.

The color measurement may comprise measuring texture of the surface of the object.

15 By means of a regular 2D color image of the patient's teeth and a color measurement of e.g. points on the patient's teeth, by means of the color measuring probe, a relative color determination of the teeth can be performed.

20 According to an aspect of the focus scanning apparatus, disclosed is a scanner for obtaining and/or measuring a 3D geometry of at least a part of a surface of an object, said scanner comprising:

- a first camera comprising an array of sensor elements,
- a first means for generating a probe light,
- means for transmitting the probe light rays towards the object thereby
- 25 illuminating at least a part of the object,
- means for transmitting light rays returned from the object to the array of sensor elements,
- a first optical system for imaging with a first depth of field on the first camera at least part of the transmitted light rays returned from the object to the array
- 30 of sensor elements,
- means for varying the position of the focus plane on the object,

- means for obtaining at least one image from said array of sensor elements,
 - means for determining the in-focus position(s) of:
 - each of a plurality of the sensor elements for a range of focus plane positions, or
 - 5 - each of a plurality of groups of the sensor elements for a range of focus plane positions, and
 - means for transforming the in-focus data into 3D coordinates;
- wherein the scanner further comprises a color measuring probe rigidly attached to the 3D scanner.

10

The color measuring probe may be suitable for measuring colors and/or translucency of e.g. teeth.

The color measuring probe may be incorporated in the focus scanning apparatus, or be removably attached to the scanner, such as by snapping
15 etc.

In some embodiments the color measuring probe is a probe suitable for measuring tooth shades.

20 In some embodiments the color measuring probe is configured to perform the measurement in at least one point on a tooth.

In some embodiments the position of the point measurement and/or the orientation of the color measurement probe relative to the object is derivable
25 due to the rigid attachment of the color measuring probe relative to the scanner.

In some embodiments the color measuring probe is adapted to be arranged perpendicular to a surface of the object.

In some embodiments the color measuring probe is a spectrophotometer system comprising:

- a probe tip including one or more light sources and a plurality of light receivers;
 - 5 - a first spectrometer system receiving light from a first set of the plurality of light receivers;
 - a second spectrometer system receiving light from a second set of the plurality of light receivers;
 - a processor, wherein the processor receives data generated by the first
 - 10 spectrometer system and the second spectrometer system,
- wherein an optical measurement of the object is produced based on the data generated by the first and second spectrometer systems.

In some embodiments the color measuring probe is for determining optical

- 15 characteristics of a translucent dental tooth, comprising:
- a probe with a tip adapted to provide light to a surface of the tooth from at least one light source, and to receive light from the tooth through at least one light receiver, the at least one light source and the at least one light receiver being spaced apart to define a minimal height as a predetermined distance
 - 20 from the surface below which no light from the at least one light source that is specularly reflected from said surface is received by the at least one light receiver,
 - light sensors coupled to the at least one light receiver for determining the intensity of light received by the light receiver, when the probe is at a point
 - 25 away from the surface of the tooth but less than the minimal height; and
 - a computing device coupled to the light sensors.

Angled mirrors and scanning with dual/multiple views simultaneously

When scanning objects it is often necessary to obtain scans from different

30 perspectives to obtain a sufficient model of the object being scanned. An

example could be the scanning of a tooth prepared for a dental restoration such as a crown and the neighboring teeth. In such a scanning situation it is necessary to scan the proximal surfaces of neighboring teeth to identify e.g. contact points on the proximal surfaces. If the scanner provides a scan with one perspective for a given relative position of the scanner and the teeth being scanned it is necessary to move the scanner to different positions and obtain individual scans in these positions. A sufficient 3D model of the scanned teeth may then be obtained by e.g. stitching of the individual scans. Such a movement of the scanner may be difficult to perform inside the oral cavity due to space limitations. It is an advantage to design the optical system in the scanner so that it may obtain more than one view even if held in one relative position relative to the teeth being scanned. Ideally, a scanner with more than one view can make a sufficient scan from just a single relative position of the scanner and the teeth being scanned. But even if a scanner that can obtain scans with more than one perspective cannot obtain a sufficient scan from a single relative position to the teeth it may still be an advantage. It may be possible that the relative movement needed is smaller than if the scanner did not have the ability to obtain scans with more than one perspective. It may also be an advantage that the scanner with more than one view is faster to operate.

US2009/0279103 discloses an apparatus for optical 3D measurement, comprising a first beam deflector for deflecting an illuminating beam onto an object to be measured and for deflecting the monitoring beam reflected from the object to be measured, wherein said first beam deflector can be moved along a path distance S . The movable deflector or translation of the deflector is provided for the purpose of reducing the height of the scanning tip in the apparatus. The present scanner eliminates the need for a movable beam deflector.

30

According to an aspect of the focus scanning apparatus, disclosed is a scanner for obtaining and/or measuring a 3D geometry of at least a part of a surface of an object, said scanner comprising:

- a first camera comprising an array of sensor elements,
 - 5 - a first means for generating a probe light,
 - means for transmitting the probe light rays towards the object thereby illuminating at least a part of the object,
 - means for transmitting light rays returned from the object to the array of sensor elements,
 - 10 - a first optical system for imaging with a first depth of field on the first camera at least part of the transmitted light rays returned from the object to the array of sensor elements,
 - means for varying the position of the focus plane on the object,
 - means for obtaining at least one image from said array of sensor elements,
 - 15 - means for determining the in-focus position(s) of:
 - each of a plurality of the sensor elements for a range of focus plane positions, or
 - each of a plurality of groups of the sensor elements for a range of focus plane positions, and
 - 20 - means for transforming the in-focus data into 3D coordinates;
- wherein the scanner further comprises at least one reflective optical element arranged in the scanner such that the reflective optical element provides for that at least two different perspective views on the acquired images is obtainable without performing movement of the scanner.

25

In some embodiments the scanner further comprises means for obtaining a first set of 3D scans and a second set of 3D scans, where the perspective views are different in the first set and in the second set of scans.

In some embodiments a first set of images with a first perspective view and a second set of images with a second perspective view are acquired simultaneously or concurrently.

- 5 In some embodiments, the scanner comprises means for obtaining 3D scans with more than one perspective. A 3D scan is made from 2D images acquired with the focus optics.

10 In some embodiments the first perspective view is fixed relative to the second perspective view.

Thus the perspectives are fixed relative to each other.

In some embodiments the scanner comprises means for switching between different perspective views of the images acquired using the first camera..

- 15 In this case it is possible to switch between different perspectives of the images on the first camera. Thus there is more than one perspective in the image, but only one perspective is shown at the time.

20 In some embodiments the scanner comprises means for combining images with different perspective views acquired using the first camera.

In this case the scanner comprises means for combining images of more than one perspective onto the first camera, thus enabling simultaneous scanning with more than one perspective.

- 25 In some embodiments the at least one reflective optical element is arranged in the tip of the scanner which is configured for pointing towards the object to be scanned.

30 In some embodiments the at least one reflective optical element comprises two dichroic mirrors or filters.

One of the mirrors or filters may be transparent to e.g. red light, and the other mirror or filter may be transparent to e.g. blue light. If the mirrors or filter are arranged in favorable positions, the scanner can scan in different directions simultaneously or concurrently, and hereby for example two different surfaces of a tooth may be scanned at one go, e.g. the lingual surface and the labial surface.

In some embodiments the at least one reflective optical element comprises a multi-facet mirror.

In some embodiments the at least one reflective optical element comprises a digital light processing (DLP).

The at least one reflective optical element may comprise pericentral optics.

In some embodiments the at least one reflective optical element and/or the other optical elements is/are adapted to generate one or more patterns to be imaged on the object while scanning.

In some embodiments the tip of the scanner is exchangeable, and where at least two different tips are adapted to fit on the scanner, where one of the tips comprises one or more mirrors arranged at about 38 degrees relative to an axis perpendicular to the optical axis, and where another of the tips comprises one or more mirrors arranged at about 45 degrees relative to an axis perpendicular to the optical axis.

The different tips may be in different colors for easy recognition by the dentist.

In some embodiments, such a tip comprises one or more mirrors arranged at an angle in the range of about 25 degrees to about 50 degrees relative to an

axis perpendicular to the optical axis, and another of the tips comprises one or more mirrors arranged at an angle in the range of about 30 degrees to about 60 degrees relative to an axis perpendicular to the optical axis.

5 In some embodiments the 3D scanning is an intra oral scanning of at least part of a patient's set of teeth, a scan of at least part of an impression of a patient's set of teeth, and/or a scan of at least part of a model of a patient's set of teeth.

10

US2009/0279103 discloses an apparatus for optical 3D measurement, comprising a first beam deflector for deflecting an illuminating beam onto an object to be measured and for deflecting the monitoring beam reflected from the object to be measured, wherein said first beam deflector can be moved
15 along a path distance S. The movable deflector or translation of the deflector is provided for the purpose of reducing the height of the scanning tip in the apparatus.

US 7,319,529 describes a retracting aperture stop that allows to stop down
20 system aperture in preview mode before scanning. Our invention eliminates the need for a retracting aperture stop and allows viewing the scanned object with a large depth of field at the same time as scanning is performed.

US 7,319,529 describes how a second light source illuminating the object
25 with a low numerical aperture can be used to generate a preview image of the object. Our invention may be used without the need for a second light source or with a second light source with a high numerical aperture.

The present invention relates to different aspects including the apparatuses
30 described above and in the following, and corresponding methods, devices, apparatuses, uses and/or product means, each yielding one or more of the

benefits and advantages described in connection with the first mentioned aspect, and each having one or more embodiments corresponding to the embodiments described in connection with the first mentioned aspect and/or disclosed in the appended claims.

5

In particular, disclosed herein is a method for obtaining and/or measuring a 3D geometry of at least a part of a surface of an object, said method comprising:

- 10 - generating a probe light by means of a first means for generating probe light,
- transmitting the probe light rays towards the object thereby illuminating at least a part of the object,
- transmitting light rays returned from the object to an array of sensor elements in a first camera,
- 15 - imaging with a first depth of field on the first camera at least part of the transmitted light rays returned from the object to the array of sensor elements by means of a first optical system,
- varying the position of the focus plane on the object,
- obtaining at least one image from said array of sensor elements,
- 20 - determining the in-focus position(s) of:
 - each of a plurality of the sensor elements for a range of focus plane positions, or
 - each of a plurality of groups of the sensor elements for a range of focus plane positions, and
- 25 - transforming the in-focus data into 3D coordinates.

Furthermore, disclosed herein is a method a method for obtaining and/or measuring a 3D geometry of at least a part of a surface of an object, said
30 method comprising :

- generating a probe light by means of a first means for generating probe light,
- transmitting the probe light rays towards the object thereby illuminating at least a part of the object,
- 5 - transmitting light rays returned from the object to an array of sensor elements in a first camera,
- imaging with a first depth of field on the first camera at least part of the transmitted light rays returned from the object to the array of sensor elements by means of a first optical system,
- 10 - varying the position of the focus plane on the object,
- obtaining at least one image from said array of sensor elements,
- determining the in-focus position(s) of:
 - each of a plurality of the sensor elements for a range of focus plane positions, or
 - 15 - each of a plurality of groups of the sensor elements for a range of focus plane positions, and
- transforming the in-focus data into 3D coordinates,
- selecting a portion of light rays returned from the object, where the light rays have been transmitted through at least a part of the first optical system; and
- 20 - capturing at least some of the selected light rays with a second depth of field substantially larger than the first depth of field by means of a second camera.

- 25 Furthermore, disclosed herein is a method for obtaining and/or measuring a 3D geometry of at least a part of a surface of an object, said method comprising :
 - generating a probe light by means of a first means for generating probe light,
 - 30 - transmitting the probe light rays towards the object thereby illuminating at least a part of the object,

- transmitting light rays returned from the object to an array of sensor elements in a first camera,
 - imaging with a first depth of field on the first camera at least part of the transmitted light rays returned from the object to the array of sensor elements
 - 5 by means of a first optical system,
 - varying the position of the focus plane on the object,
 - obtaining at least one image from said array of sensor elements,
 - determining the in-focus position(s) of:
 - 10 - each of a plurality of the sensor elements for a range of focus plane positions, or
 - each of a plurality of groups of the sensor elements for a range of focus plane positions, and
 - transforming the in-focus data into 3D coordinates,
- wherein the method further comprises performing spectral analysis of the
- 15 light returned from the object.

- Furthermore, disclosed herein is a method for obtaining and/or measuring a 3D geometry of at least a part of a surface of an object, said method
- 20 comprising :
- generating a probe light by means of a first means for generating probe light,
 - transmitting the probe light rays towards the object thereby illuminating at least a part of the object,
 - 25 - transmitting light rays returned from the object to an array of sensor elements in a first camera,
 - imaging with a first depth of field on the first camera at least part of the transmitted light rays returned from the object to the array of sensor elements by means of a first optical system,
 - 30 - varying the position of the focus plane on the object,
 - obtaining at least one image from said array of sensor elements,

- determining the in-focus position(s) of:
 - each of a plurality of the sensor elements for a range of focus plane positions, or
 - each of a plurality of groups of the sensor elements for a range of focus plane positions, and
- 5 - transforming the in-focus data into 3D coordinates, wherein the method further comprises performing a color measurement by means of a color measuring probe rigidly attached to the 3D scanner.
- 10 Furthermore, disclosed herein is a method for obtaining and/or measuring a 3D geometry of at least a part of a surface of an object, said method comprising :
 - generating a probe light by means of a first means for generating probe light,
 - 15 - transmitting the probe light rays towards the object thereby illuminating at least a part of the object,
 - transmitting light rays returned from the object to an array of sensor elements in a first camera,
 - imaging with a first depth of field on the first camera at least part of the transmitted light rays returned from the object to the array of sensor elements
 - 20 by means of a first optical system,
 - varying the position of the focus plane on the object,
 - obtaining at least one image from said array of sensor elements,
 - determining the in-focus position(s) of:
 - 25 - each of a plurality of the sensor elements for a range of focus plane positions, or
 - each of a plurality of groups of the sensor elements for a range of focus plane positions, and
 - transforming the in-focus data into 3D coordinates,
 - 30 wherein the method further comprises providing that at least two different perspective views on the acquired images is obtainable without performing

movement of the scanner by means of at least one reflective optical element arranged in the scanner.

Furthermore, disclosed herein is an optical system for obtaining and/or
5 measuring a 3D geometry of at least a part of a surface of an object, said optical system comprising:

- a first camera comprising an array of sensor elements,
- a first means for generating a probe light,
- means for transmitting the probe light rays towards the object thereby
10 illuminating at least a part of the object,
- means for transmitting light rays returned from the object to the array of sensor elements,
- a first optical system for imaging with a first depth of field on the first camera at least part of the transmitted light rays returned from the object to the array
15 of sensor elements,
- means for varying the position of the focus plane on the object,
- means for obtaining at least one image from said array of sensor elements,
- means for determining the in-focus position(s) of:
 - each of a plurality of the sensor elements for a
20 range of focus plane positions, or
 - each of a plurality of groups of the sensor elements for a range of focus plane positions, and
- means for transforming the in-focus data into 3D coordinates.

25

Disclosed is a scanner for obtaining and/or measuring a 3D geometry of at least a part of a surface of an object, said scanner comprising:

- a light first source configured for generating a probe light;
- 30

- a first camera comprising an array of sensor elements, where said camera is configured for obtaining at least one image from said array of sensor elements;
- 5 - an arrangement of optical components configured for:
 - transmitting the probe light rays towards the object such that at least a part of the object can be illuminated;
 - transmitting light rays returned from the object to the array of sensor elements; and
 - 10 imaging with a first depth of field at least part of the transmitted light rays returned from the object onto the array of sensor elements;

where the arrangement of optical components comprises focusing optics that defines a focus plane for the scanner,

- 15 - a positioning device configured for varying the position of the focusing optics, such that the position of the focus plane relative to the scanner is changed,
- 20 - a data processing device, configured for determining the in-focus position(s) of:
 - each of a plurality of the sensor elements for a range of focus plane positions, or
 - each of a plurality of groups of the sensor elements for a range of
 - 25 focus plane positions,and for transforming the in-focus data into 3D coordinates.

In some embodiments, the scanner comprises:

- 30 - optics for selecting a portion of light rays returned from the object, and

- a second camera arranged to capture at least some of the selected light rays, where the second camera is configured for obtaining a second depth of field image with a second depth of field which is substantially larger than the first depth of field.

5

In some embodiments, the scanner comprises:

- optics for selecting a portion of light rays returned from the object;
- a second camera arranged to capture at least some of the selected light rays; and

10 - optical components arranged to image at least part of the selected portion of the light rays returned from the object onto the second camera with a second depth of field which is substantially larger than the first depth of field.

15 The positioning device configured for varying the position of the focusing optics allows for a change of the position of the focus plane on the object while maintaining the relative positions of the scanner and the object.

20 Disclosed is a scanner for obtaining and/or measuring a 3D geometry of at least a part of a surface of an object arranged in a scan volume, said scanner comprising:

- a light first source configured for generating a probe light;

25

- a first camera comprising an array of sensor elements, where said camera is configured for obtaining at least one image from said array of sensor elements;

30 - an arrangement of optical components configured for

- transmitting the probe light rays towards the scan volume such that at least part of an object arranged in said scan volume can be illuminated; transmitting light rays returned from the scan volume to the array of sensor elements; and
- 5 imaging with a first depth of field at least part of the transmitted light rays returned from the scan volume onto the array of sensor elements;

where the arrangement of optical components comprises focusing optics that defines a focus plane for the scanner, and where the focus plane is located in

10 said scan volume;

- a positioning device configured for varying the position of the focusing optics, such that the position of the focus plane is scanned through said scan volume;
- 15
- a data processing device, configured for determining the in-focus position(s) of:
 - each of a plurality of the sensor elements for a range of focus plane positions, or
 - 20 - each of a plurality of groups of the sensor elements for a range of focus plane positions,
- and for transforming the in-focus data into 3D coordinates.

25 When the object and the scanner are arranged relative to each other such that at least part of the object is within said scan volume, the position of the focus plane on the object may be changed when the focus plane is scanned through the scan volume.

In some embodiments, the scan volume is the volume which is scanned when the focusing optics is moved between its outermost positions while maintaining a substantially constant position of the scanner.

- 5 In some embodiments, the scan volume is the volume spanned by the focus plane between its outermost positions relative to the scanner while maintaining a substantially constant position of the scanner.
- 10 Furthermore, the invention relates to a computer program product comprising program code means for causing a data processing system to perform the method according to any of the embodiments, when said program code means are executed on the data processing system, and a computer program product, comprising a computer-readable medium having stored
- 15 there on the program code means.

In some embodiments, the focusing optics is part of the first optical system. The focusing optics may be a lens in a lens system.

- 20 In some embodiments, the position of the focus plane is varied on the object by varying the position of the focusing optics in the scanner, such as varying the position relative to other parts of the scanner, such as relative to the casing of the scanner. The means for varying the focusing optics may hence also vary the position of the focus plane on the object.

- 25 In some embodiments, the means for varying the position of the focusing optics and hence the focus plane on the object comprises a positioning device, such as a translation stage, for adjusting and controlling the position of the focusing optics. By translating the focusing optics back and forth along
- 30 the optical axis of the first optical system, the position of the focus plane relative to the scanner may be varied. The position of the focus plane over a

scanned object can hence be moved without moving the scanner relative to the object.

5 Identified in-focus position(s) for sensor elements or groups of sensor elements can be related to 3D coordinates by ray tracing through the first optical system. Such ray tracing may require that the parameters of the first optical system are known. Such knowledge can be obtained by a calibration, such as calibration in which images of an object of known geometry are recorded for a plurality of in-focus positions. Such an object may be a planar checkerboard pattern. Then, the scanner can be calibrated by generating simulated ray traced images of the calibration object and adjusting first optical system parameters as to minimize the difference between simulated and recorded images.

15 With knowledge of the parameters of the first optical system, one can employ backward ray tracing technique to estimate the 2D -> 3D mapping. This requires that the scanner's first optical system be known, preferably through calibration. The following steps can be performed:

20 1. Trace a certain number of rays from each sensor element, starting from the array of sensor elements and through the first optical system (backward ray tracing).

2. Calculate the point where all the traced rays from the sensor element substantially intersect, i.e. the focus point for the sensor element. This point represents the 3D coordinate where a portion of an imaged object will be in focus for this sensor element.

25 3. Generate a look up table for all the sensor elements with their corresponding 3D coordinates.

The above steps are repeated for a number of different positions of the focusing optical covering the scanner's operation range.

30

The method may also be performed in the case where the sensor elements are combined in groups of sensor elements.

5 In some embodiments, the means for determining the in-focus positions comprises a data processing device, such as a computer or a microprocessor. The determining may utilize computer implemented algorithms implemented in a computer program product tangibly embodied in a machine-readable storage device for execution by a programmable processor.

10

In some embodiments, the means for transforming the in-focus data into 3D coordinates comprises a data processing device, such as a computer or a microprocessor. The transforming may utilize computer implemented algorithms implemented in a computer program product tangibly embodied in a machine-readable storage device for execution by a programmable processor.

15

The in-focus positions may be determined using the same data processing device which is used for transforming the in-focus data into 3D coordinates, or the determining and the transforming may be carried out using two separate data processing devices.

20

In some embodiments, the first means for generating a probe light comprises a light first source, such as a monochromatic light source, a semi-monochromatic light source, or a broadband source light source providing light over a wavelength range.

25

In some embodiments, the first light source is an ultraviolet light source, an infra-red light source and/or a light source emitting in the visible part of the electromagnetic spectrum.

30

A broadband source may be configured for providing light substantially at all wavelengths in the wavelength range, such as to provide light in a substantially continuous wavelength range. In some embodiments, the broadband source emits white light, i.e. the wavelength range covers
5 substantially the entire range of wavelengths in within the visible part of the electromagnetic spectrum.

Pseudo-broadband light can also be generated by combining a number of monochromatic or semi-monochromatic light sources with wavelengths
10 distributed over the range of wavelengths. The first light source may comprise at least three monochromatic light sources with wavelengths distributed across the visible part of the electromagnetic spectrum. I.e. a probe light of different colors may be provided by at least three monochromatic or narrow-band light sources, such as lasers or LED's, said
15 light sources having wavelengths distributed across the visible part of the wavelength spectrum. This will in general also require means for merging said light sources, such as suitable coated plates.

When the first light source is configured for emitting light over a range of
20 wavelengths, color information can be obtained from the object.

In some embodiments, the means for obtaining at least one image from said array of sensor elements comprises electronic devices configured for converting signals from the array of sensor elements into an image.
25

In some embodiments, the scanner comprises a nontransitory computer readable medium having one or more computer instructions stored thereon, where said computer instructions comprises instructions for carrying out a method of measuring of a 3D geometry of at least a part of a surface of an
30 object.

Disclosed is a scanner system comprising

- a focus scanning apparatus according to the present invention; and
 - a data processing device comprising a nontransitory computer readable medium having one or more computer instructions stored thereon, where
- 5 said computer instructions comprises instructions for carrying out a method of the present invention.

Definitions

- 10 Optical axis: the optical axis of an optical system is the axis defined by a straight line through the light source, the optics and the lenses in this optical system.

- Optical path: the path of the light from the light source to the object and back
- 15 to the camera. The optical path may change direction, e.g. by means of beam splitter and folding optics.

- Optical system: Arrangement of one or more optical components. Optical component could be, but is not limited to: Optical lenses, mirrors, gratings,
- 20 polarizers, retardation plates, filters, beam splitters.

- Image / imaging: An image can be viewed as a 1D or 2D array of values, when obtained with a digital camera, or in optics, a 1D or 2D image indicates that there exists a relation between an imaged curve/surface and an image
- 25 curve/surface where light rays emerging from one point on said imaged curve/surface substantially converge on one point on said image curve/surface.

- Depth of field (DoF): In imaging the convergence of rays from one point in an
- 30 imaged curve/surface onto the image curve/surface is best obtained for one particular imaged curve/surface. Light emitted from other curves/surfaces in

front of or behind the imaged surface does not converge to form images on the image surface to the same degree. In practice, however, light rays from surfaces in front of and behind the image surface may still converge to form acceptable images on the imaged surface. The DoF is the distance along this depth direction where it is possible to form acceptable images.

Perspective: A perspective of an image is specified by the position and orientation of the camera when the picture was taken. If two cameras have a fixed perspective with respect to each other it implies that they move in rigid synchronization to each other.

Aperture: The aperture of an optical system is the opening in the optical system that determines the cone angle of a bundle of rays that come to a focus in the image plane. The aperture can be a plate with a hole in it, it can also be a lens or another optical component.

Downstream: Direction from light source towards object being scanned.

Upstream: Opposite direction of downstream.

3D real world coordinates and/or 3D geometry: 3D real world coordinates and/or 3D geometry is based on a 3D representation, i.e. a 3D digital representation, which can be either point clouds, surface, such as faceted / meshed, or volumetric. A 3D model, i.e. a 3D digital model, can be generated from a 3D representation. Faceted/meshed representations can be generated from point clouds, for example by triangulation. Volumetric models can be obtained with a scanner applying penetrating radiation, such as CT scanners.

Brief description of the drawings

The above and/or additional objectives, features and advantages of the present invention, will be further elucidated by the following illustrative and

non-limiting detailed description of embodiments of the present invention, with reference to the appended drawings, wherein:

Fig. 1 shows an example of a prior art focus scanning apparatus.

5

Fig. 2 shows an example of a focus scanning apparatus comprising a second camera.

Fig. 3 shows an example of a focus scanning apparatus comprising a second camera capable of producing a color image.

10

Fig. 4 shows an example of a focus scanning apparatus which provides for illuminating the object being scanned with the same perspective for both the first light source and the second light source.

15

Fig. 5 shows an example of a focus scanning apparatus with a second light source.

Fig. 6 shows an example of a focus scanning apparatus where the second light source is coupled to a wave guide.

20

Fig. 7 shows examples of color filters for use in the second camera.

Fig. 8 shows an example of a focus scanning apparatus configured for performing a spectral analysis using a second camera..

25

Fig. 9 shows an example on how the second camera may be used for spectral analysis.

Fig. 10 shows an example of a focus scanning apparatus which enables the object being scanned to be seen from two different perspectives in the scanning.

30

Fig. 11 shows an example of a focus scanning apparatus with a color measurement probe.

5 Fig. 12 shows an example of a set of teeth with regions of different color.

Fig. 13 shows an example of a focus scanning apparatus comprising a miniature second camera arranged in the aperture.

10 Fig. 14 shows a one camera embodiment capable of obtaining both shallow and large depth of field images.

Fig. 15 shows the use of a focus scanning device with a color measurement probe attached.

15

Detailed description

In the following description, reference is made to the accompanying figures, which show by way of illustration how the invention may be practiced.

Fig. 1 shows an example of a prior art focus scanning apparatus. The prior art scanner is a hand-held scanner with all components inside the housing (head). The scanner head comprises a tip which can be entered into a cavity, a light source 110, optics to collect the light from the light source, pattern generation means 130, a beam splitter 140, an image sensor and electronics 180, a lens system which transmits and images the light between the pattern, the object being scanned, and the image sensor (camera) 180. The light from the light source 110 travels back and forth through the optical system 150. During this passage the optical system images the pattern 130 onto the object being scanned and further images the object being scanned

onto the image sensor 181. The lens system includes a focusing element 151 which can be adjusted to shift the focal imaging plane of the pattern on the probed object. One way to embody the focusing element is to physically move a single lens element back and forth along the optical axis. The device
5 may include polarization optics. The device may include folding optics 170 which directs the light out of the device in a direction different to the optical axis of the lens system, e.g. in a direction perpendicular to the optical axis of the lens system. As a whole, the optical system provides an imaging of the pattern onto the object being probed and from the object being probed to the
10 camera. One application of the device could be for determining the 3D structure of teeth in the oral cavity. Another application could be for determining the 3D shape of the ear canal and the external part of the ear.

The optical axis in fig. 1 is the axis defined by a straight line through the light
15 source 110, optics and the lenses in the optical system 150. This also corresponds to the longitudinal axis of the scanner illustrated in fig. 1. The optical path is the path of the light from the light source 110 to the object and back to the camera 180. The optical path may change direction, e.g. by means of beam splitter 140 and folding optics 170.

20

The focus scanning apparatus comprises a flat scan tip with large scan length, using a plurality of, e.g. dichroic, mirrors and light sources.

The configuration of the focus scanning apparatus allows for a scan tip with a smaller height than the scan length. The light from two sources 110 and 111
25 emitting light of different colors/wavelengths is merged together using a suitably coated plate, e.g. a dichroic filter, 112 that transmits the light from light source 110 and reflects the light from light source 111. At the scan tip a suitably coated plate, e.g. a dichroic filter, 171 reflects the light from one source onto the object and transmits the light from the other source to a
30 mirror at the end of the scan tip 172. During scanning the focus position is moved such that the light from light source 110 is used to project an image of

the pattern to a position below 171 while light source 111 is switched off. The 3D surface of the object in the region below 171 is recorded. Then light source 110 is switched off and light source 111 is switched on and the focus position is moved such that the light from light source 111 is used to project
5 an image of the pattern to a position below 172. The 3D surface of the object in the region below 172 is recorded. The region covered with the light from light sources 110 and 111 respectively may partially overlap.

Fig. 2 shows an example of a focus scanning apparatus comprising a second
10 camera.

The focus scanning apparatus 200 comprises a light source 210 that may comprise collimation optics, a pattern 220, a first camera 230, a first optical system 240 comprising a beam splitter 250 that may be polarizing, focusing optics 260, an aperture 270, and other optical elements 280. The focus
15 scanning apparatus is aimed at the object being scanned 290. Some light rays emitted from the light source and imaged through the first optical system onto the object being scanned, returned through the first optical system and imaged onto the camera are illustrated as dotted lines. The depth of field a , which is the distance between the arrows, of the image of the object on the
20 first camera 230 is small thanks to a large aperture 270 in the first optical system 240.

Here the optical components of the first optical system, i.e. the beam splitter 250, the focusing optics 260, the aperture 270, and the other optical
25 elements 280, are arranged to both transmit the probe light rays towards the object and to transmit light rays returned from the object to the array of sensor elements. That is, the means for transmitting the probe light rays towards the object thereby illuminating at least a part of the object, and the means for transmitting light rays returned from the object to the array of
30 sensor elements are the same and are part of the first optical system.

- During a 3D scan the focus of the first optical system is swept from one end of the focus volume to the other end by adjusting the focusing optics 260 indicated by the double arrow. The focus sweep translates the focus in a direction substantially along the optical axis of the first optical system 240.
- 5 During the focus sweep a stream of images is obtained with the camera 230. The in-focus regions of the images in the sweep are determined and from this 3D coordinates of at least a part of the object being scanned is determined.
- 10 A part of the light returned from the object 290 and transmitted through the other optical elements 280 of the first optical system 240 are reflected by a second optical element 300, such as a small mirror, a beam splitter, a filter etc., placed in the aperture 270. The reflected rays are transmitted to a second optical system 310 and a second camera 320. The second optical
- 15 system 310 together with the other optical elements 280 forms an image of at least a part of the object 290. The aperture in the optical system comprising the other optical elements 280 and the second optical system 310 can be coincident with the aperture of the first optical system 240. In this case the size of the aperture is determined by the size of the mirror 300. Since this
- 20 mirror is small then the depth of field of the image on the second camera 320 is larger than the depth of field of the image(s) on the camera 230. In the figure this larger depth of field is denoted **b**. Since the mirror 300 is small compared to the dimensions of the aperture 270 it is only a small fraction of the light rays returned from the object that are reflected by the mirror. Since
- 25 the mirror 300 is placed in the aperture of the first optical system 240 the field of view of the first camera 230 is not reduced, i.e. the view to no part of the object is obstructed compared to what could be seen without the small mirror 300. The presence of the small mirror 300 does not substantially affect the 3D scanning. The depth of field of the image on the second camera 320 is
- 30 preferably so large that all parts of the object being scanned 290 are in focus at the same time. Since in this figure the focusing optics 260 is outside of the

light path from the light returned from the object to the second camera, then the image on the second camera is substantially unaffected by the 3D scanning process, which is performed by means of the focusing optics.

5 The frame rate on the second camera 320 can be different than the frame rate on the first camera 230 and the rate of 3D scanning. It may be preferred that the frame rate on the second camera 320 is higher than the rate of 3D scanning but smaller than the frame rate of the first camera 230. The image from the second camera can be displayed to the operator of the scanner and
10 allow to give a real-time view of the scanned area. This can help the operator in adjusting the relative position and orientation of the scanner and the object being scanned. This can be particularly useful in a handheld scanner.

It is often advantageous to use near-monochromatic light for the 3D
15 scanning. Using near-monochromatic light makes the construction of the first optical system 240 simpler. It may in other words be advantageous to have a near-monochromatic first light source 210. But at the same time it may be advantageous to obtain a color image of the object being scanned with the second camera. A large depth of field image in color may be an advantage if
20 it is an objective to overlay color texture onto the 3D surface or 3D model of the object. A color image could also be an advantage in assistance with aiming the scanner towards the object being scanned. Or a color image could simply give a better user experience when operating the scanner compared to a black-and-white image.

25 The reference numbers in fig. 2 are also used to denote corresponding features in the following figures. Likewise, reference numbers in the following figures may also be used to denote corresponding features in the other following figures.

30

Fig. 3 shows an example of a focus scanning apparatus comprising a second camera capable of producing a color image.

The focus scanning apparatus provides for a color image on the second camera 320 while at the same time using near-monochromatic light for the 3D scanning. This is possible by using a second light source 330 with a different wavelength spectrum than the near-monochromatic first light source 210 together with a color camera. The second light source 330 can preferably be a white-light source and it is understood that the second light source can comprise collimation optics. The white-light illumination may potentially disturb the 3D scanning if the white light is transmitted to the first camera 230. This disturbance may be minimized by having a transmission filter 340 placed in the first optical system 240. This filter should allow transmission of the first light source 210 while diminishing or completely preventing passage of light from the second light source 330. One way to achieve this is to have e.g. an infrared first light source 210 and a white second light source 330 and use a filter 340 that only transmits infrared light. Another way to achieve this is to have a narrow band first light source 210 in the visible range and a white second light source 330 and use a filter 340 that is pass-band to allow transmission of the light from the light source 210 while not allowing transmission of other wavelengths within the visible range. Such a filter would allow transmission of a small fraction of the white light from the second source 330. But this small fraction could be too small to disturb the 3D scanning appreciably. The second camera 320 is in this figure a color camera, and the camera may obtain color images by applying a color filter array such as a Bayer color filter array to a black-and-white sensor. Alternatively the camera could obtain color images by using three sensors and a trichroic beam splitter to split the white-light image into red, green, and blue images.

If a second light source 330 is used then it may be advantageous to have this light source placed so that it illuminates the object 290 with the same

perspective as the first light source 210. This is because then all parts of the object being scanned by means of the first light source 210 are also illuminated by the second light source 330.

5 The figure shows that the second light source is arranged in the scanner proximal to the object being scanned, i.e. the light source is arranged in the end of the scanner which points towards the object being scanned. However, other locations of the second light source inside and outside the scanner may also be possible for obtaining the desired effect as described above.

10

Fig. 4 shows an example of a focus scanning apparatus which provides for illuminating the object being scanned with the same perspective for both the first light source and the second light source.

The focus scanning apparatus 200 comprises a first light source 210 and a
15 second light source 330 for illuminating the object 290 with the same perspective. This is possible by using a beam splitter 350 that combines the optical path of the second optical system 310 and the second light source 330. The light from the second light source 330 is then by means of the mirror 300 brought to propagate along the optical axis of the first optical system 240 and it is transmitted through a part of the first optical system.
20

The figure shows that the second light source is arranged near the second optical system. However, other locations of the second light source may also be possible for obtaining the desired effect as described above.

25 For example it may be advantageous to have the second light source 330 placed in or just outside the aperture 270 of the first optical system 240. This is because when the second light source is so placed then it will illuminate the same portion of the object being scanned as the first light source.

30 Fig. 5 shows an example of a focus scanning apparatus with a second light source.

In the figure, the second light source 330 is placed just outside the aperture 270 of the first optical system 240.

However, other locations of the second light source may also be possible for obtaining the desired effect as described above.

5

For space considerations it may also be advantageous to place the second light source at a position away from the object being scanned. The light can then be transmitted to the object being scanned by means of one or more wave guides.

10

Fig. 6 shows an example of a focus scanning apparatus where the second light source is coupled to a wave guide.

The figure shows that the second light source 330 is coupled to a wave guide 360 that transmits the light to the object being scanned. It is understood that the second light source 330 includes coupling optics to couple the light into the waveguide. The figure shows that the waveguide 360 is split into two so that the light from the second light source 330 is emitted from the end of two waveguides. This is provided to achieve that the illumination of the object becomes more uniform and to ensure that fewer parts of the surface of the object is left in shadow. The waveguide can be split into more than two to make the illumination even more uniform and with even fewer areas in shadow.

15

20

It is also possible to have a third, fourth etc. light source to illuminate the object being scanned. If wave guides are used then it may be natural to have one wave guide per light source.

25

As an alternative to a white light second light source 330 and a color second camera 320 it is possible to have a second light source 330 that emits near-monochromatic light and a black-and-white camera 320 and still obtain color images with large depth of field. One way to do this is to have a second light

30

source 330 that can change color. At different times the light source can emit red, green and blue light. This is possible with a second light source comprising e.g. red, green, and blue LEDs that can be turned on and off at different times. The second light source could then emit red, green, and blue
5 light in sequence. The black and white second camera 320 can then obtain the corresponding red, green, and blue images. These images can then be combined to one full-color image. If the acquisition of the red, green, and blue images is sufficiently fast, then there is substantially no relative motion
10 between the scanner and the object being scanned, even though the apparatus is hand-held and thus moved, and it is straight-forward to combine the three images into one color image. Sufficiently fast could mean that the three images are acquired within e.g. 1/20 s.

The acquisition of color images with the second camera 320 does not necessarily imply that the camera only records red, green, and blue
15 components of the image. High-precision color analysis may require more than three individual color components. This could be the case for e.g. determination of tooth shade when scanning teeth. The visible spectrum could be covered with a larger set of individual colors. Such detailed color analysis is generalizable from the color image schemes described in the
20 above.

Fig. 7 shows examples of color filters for use in the second camera.

Fig. 7a shows one period of a Bayer color filter array for obtaining color
25 images in a camera, which can be used in the second camera and thus in the apparatus. This type of color filter array is well known in the art.

Fig. 7b shows one period of a color filter array with a larger set of individual colors, which can be used in the second camera and thus in the apparatus. .
30 Each number corresponds to a color filter with a pass-band transmission schematically indicated in fig. 7c.

Fig. 8 shows an example of a focus scanning apparatus configured for performing a spectral analysis.

Here one dimension of the 2D second camera 320 is used as a spatial dimension while the other dimension of the 2D second camera 320 is used as a spectral dimension. This is achieved in the following way: Light rays are selected by a small second optical element 300, e.g. mirror, in the aperture 270 of the first optical system 240 and imaged onto a slit 390. The slit selects a 1D portion of the image which then is spectrally analyzed by projecting the 1D portion onto a diffractive optical component 400, such as a grating, where the diffractive optical component is arranged to diffract each section of the 1D portion of the image into a plane perpendicular to the 1D portion. Additional optics guides the diffracted light rays onto the 2D sensor array in the second camera 320 such that it obtains a spectrum for each portion of the 1D portion of the image. In this case the second light source can preferably be a white-light source, and it is understood that the second light source can comprise collimation optics.

Fig. 9 shows an example on how the second camera may be used for spectral analysis.

A portion of the light rays returning from the object 290 are selected by the second optical element and imaged onto a slit 390 which then selects a 1D portion 391 of the 2D distribution of the light rays. The 1D portion 391 is then projected onto a diffractive optical component 400, such as a grating, where the diffractive optical component 400 is arranged to diffract each section 401, 402 of the 1D portion 391 into a plane perpendicular to the longitudinal axis of the 1D portion 391. Additional optics may be arranged to guide the diffracted light rays onto the 2D array of sensor elements 321 in the second camera such that different colors of the light in one section is diffracted into a wavelength specific angle and hence onto a wavelength specific sensor element. There is hence a correlation between each sensor element in the

array of sensor elements and the wavelength of light rays in a section of the selected 1D portion. From knowledge of this correlation, obtained e.g. by a prior calibration of the scanner, a spectrum can be obtained for each section 401, 402 of the 1D portion 391. A light ray received by sensor elements 322
5 is hence originating from the same portion 291 of object 290 as the light ray received by sensor element 323, but has a different wavelength. On the other hand the light ray received by sensor element 324 has the same wavelength as the light ray received in sensor element 322 but originates from a different portion 292 of the object 290. When scanning the object by moving the
10 scanner relative to the object, the surface can be scanned to obtain both spatial and texture information.

The geometrical data obtained from the 1D portion may also be used for registration of the color data into a previously obtained 3D model of the object.

15 In this scanner embodiment, the second light source should preferably be a broadband source, such as a white-light source. It is understood that the second light source can comprise collimation optics.

This embodiment hence provides that one dimension of the second camera is used to obtain information relating to the spatial properties of the object,
20 while the other dimension of the second camera is used for obtaining spectra information.

Fig. 10 shows an example of a focus scanning apparatus which enables the
25 object being scanned to be seen from two different perspectives in the scanning.

The light from two light sources 110 and 111 emitting light of different colors/wavelengths is merged together using a suitably coated plate 112, e.g. a dichroic filter that transmits the light from light source 110 and reflects the
30 light from light source 111. At the scan tip a suitably coated plate 171, e.g. a dichroic filter, reflects the light from one light source onto the object and

transmits the light from the other light source to a filter or mirror 172 at the end of the scan tip.

During scanning the focus position is moved by means of the focus lens 151, such that the light from light source 110 is used to project an image of the pattern to a position below 171 while 111 is switched off. The 3D surface of the object in the region below 171 is recorded. Then light source 110 is switched off and light source 111 is switched on and the focus position is moved such that the light from light source 111 is used to project an image of the pattern to a position below 172. The 3D surface of the object in the region below 172 is recorded. The region covered with the light from light sources 110 and 111 respectively may partially overlap.

In this example, the dichroic filters or mirrors 171 and the mirror 172 are purposely put at an angle with respect to each other. This means that the scan volumes 190 and 191 below the filters or mirrors 171 and 172 have an overlap, and the object being scanned is thus seen from two different perspectives in these volumes 190, 191. Together the dichroic filters or mirrors 171 and the mirror 172 act as a reflective optical element which provides that two different perspective views on the acquired images can be obtained without moving the scanner relative to the object.

20

Fig. 11 shows an example of a focus scanning apparatus with a color measurement probe.

The scanner 200 comprises a color measuring probe 380 rigidly attached to the 3D scanner.

25 The color measuring probe 380 is arranged such that it is suitable for measuring the shades of the object 290, e.g. tooth, which the focus scanning optics are obtaining the 3D geometry of.

The color measuring probe 380 is configured to perform the color measurement in at least one point on a tooth. In some cases the color may be measured in e.g. two points or more on a tooth. The color of a tooth may be different along its length due to e.g. different thickness of the tooth.

30

The position of the point measurement and/or the orientation of the color measurement probe 380 relative to the object 290 is derivable due to the rigid attachment of the color measuring probe 380 relative to the scanner 200.

5 The color measuring probe 380 may be arranged perpendicularly to a surface of the object 290.

The color measuring probe 380 may comprises a probe tip including one or more light sources and a plurality of light receivers, spectrometer system(s) for measuring the color of the object, a processor for processing the
10 measured data etc.

In the figure the color measuring probe is shown to be arranged in top on the scanner. However, the probe may be arranged anywhere suitable on or in the scanner, such as on the side, below, in the front, in the back etc.

15

Fig. 12 shows an example of a set of teeth with regions of different color.

The set of teeth 1100 comprises a number of teeth, e.g. the upper front teeth.

The teeth may be color measured with a color measuring probe, see fig. 10.

The color measurement shows that the tooth 1101 comprises three different
20 color regions, where color region 1102 is the region closest to the gingival, and this region may have the color A5. The region 1103 is the center region of the tooth 1101 and this region may have the color A6. The region 1104 is the region closest to the incisal edge of the tooth and this region may have the color A7.

25 The color measurement further shows that the tooth 1108 comprises two different color regions, where color region 1105 is the region closest to the gingival, and this region may have the color A6. The region 1106 is the region closest to the incisal edge of the tooth and this region may have the color A7.

30

The color codes A5, A6, and A7 are randomly chosen and may not have any relation to real color codes of teeth.

Fig. 13 shows an example of a focus scanning apparatus comprising a miniature second camera arranged in the aperture.

5 Instead of having a mirror 300 placed in the aperture 270 to reflect a part of the light returned from the object 290 and transmitted through the other optical elements 280, the second camera 320 is here a miniature camera arranged in the aperture 270.

10 Since the second camera 320 is small compared to the dimensions of the aperture 270 when using a miniature camera it is only a small fraction of the light rays returned from the object that are collected by the second camera 320. Since the second camera 320 is placed in the aperture of the first optical system 240 the field of view of the first camera 230 is not reduced. The depth
15 of field of the image on the second camera 320 is preferably so large that all parts of the object being scanned 290 are in focus at the same time. One miniature camera which can be used is the NanEye 2B 1mm 62k pixels miniature camera provided by AWAIBA. The size of this camera is: 1mm x 1mm x 1.5mm (W L H). Another suitable miniature camera is the IntroSpicio™
20 120 from Medigus. This video camera has a diameter of 1.2 mm and a length of 5 mm.

Fig 14 shows a single-camera embodiment capable of obtaining both shallow
25 and large depth of field images.

Compared to the embodiment illustrated in Fig. 2, the embodiment of Fig. 14 comprises a first optical element 271 instead of the second optical element, second optical system, and second camera of Fig. 2. The change of the field of depth between a relatively smaller first depth of field and a relatively larger
30 second depth of field on the first camera is provided by a change in the effective area of the aperture 270. The first optical element 271 may be a

automatically adjustable iris diaphragm arranged with its center at the optical axis of the focus scanning apparatus. When the aperture of the iris diaphragm is reduced, the depth of field by which the light rays returning from the object are imaged onto the first camera increases.

- 5 The first optical element 271 may alone define the aperture 270 such that the two are one integrated component.

10 Fig 15 shows the use of a focus scanning apparatus with a color measurement probe attached. Here the color measuring probe 380 is seen as being rigidly attached to the focus scanning apparatus 200 but it could also be an integrated part of the focus scanning apparatus.

15 Fig. 15a illustrates how the focus scanning apparatus can be arranged when it is moved relative to the object 290 in order to obtain data for the 3D geometry of a surface of the object. The dotted lines 205 indicate the boundaries of the scan volume of the focus scanning apparatus.

When acquiring data relating to the color of the object 290, the color measuring probe 380 is brought into close proximity with the object surface as illustrated in Fig. 15b. The relative arrangement of the color measuring probe 380 and the focus scanning apparatus 200 (or the remaining components of the scanner) is such that the color measuring probe 380 can obtain color data from one section 207 of the object 290 while geometrical data simultaneously can be acquired from another section 206 of the object 290 by the focus scanning optics of the focus scanning apparatus. The geometrical data acquired for a certain color measurement can be used for aligning the measured color with the 3D model derived from the geometrical data obtained with the scanner arranged as seen in Fig.15a. A registration of the color data for one or more sections of the object can then provide that the 3D model of the object is colored according to the true color of the object.

30 The coloring of the 3D model may utilize a smoothing algorithm configured

for smoothly changing the color of the object between colors measured at different sections of the object.

The scanning of the surface to obtain the 3D geometry can be performed first such that the 3D geometry is known before the color data are acquired. In this case, the registration of the color data into the 3D model of the object can be performed during the color data acquisition and the color data can be displayed together with the geometrical data. An advantage of this approach is that an operator based on the visualization of the color and geometrical data can determine when he has acquired a sufficient amount of color data.

10

Alternatively, the color measurement can be performed before the 3D scanning of the object and stored in a memory unit. When the 3D geometry is obtained, the registration of the color data onto the 3D geometry can be performed.

15

Although some embodiments have been described and shown in detail, the invention is not restricted to them, but may also be embodied in other ways within the scope of the subject matter defined in the following claims. In particular, it is to be understood that other embodiments may be utilized and structural and functional modifications may be made without departing from the scope of the present invention.

20

In device claims enumerating several means, several of these means can be embodied by one and the same item of hardware. The mere fact that certain measures are recited in mutually different dependent claims or described in different embodiments does not indicate that a combination of these measures cannot be used to advantage.

25

It should be emphasized that the term "comprises/comprising" when used in this specification is taken to specify the presence of stated features, integers,

30

steps or components but does not preclude the presence or addition of one or more other features, integers, steps, components or groups thereof.

5 The features of the method described above and in the following may be implemented in software and carried out on a data processing system or other processing means caused by the execution of computer-executable instructions. The instructions may be program code means loaded in a memory, such as a RAM, from a storage medium or from another computer via a computer network. Alternatively, the described features may be
10 implemented by hardwired circuitry instead of software or in combination with software.

Claims:

1. A scanner for obtaining and/or measuring a 3D geometry of at least a part of a surface of an object, said scanner comprising:
- 5 - a first camera comprising an array of sensor elements,
- a first means for generating a probe light,
- means for transmitting the probe light rays towards the object thereby illuminating at least a part of the object,
- means for transmitting light rays returned from the object to the array of
10 sensor elements,
- a first optical system for imaging with a first depth of field on the first camera at least part of the transmitted light rays returned from the object to the array of sensor elements,
- means for varying the position of the focus plane on the object,
15 - means for obtaining at least one image from said array of sensor elements,
- means for determining the in-focus position(s) of:
- each of a plurality of the sensor elements for a range of focus plane positions, or
- each of a plurality of groups of the sensor elements
20 for a range of focus plane positions, and
- means for transforming the in-focus data into 3D coordinates.
2. A scanner for obtaining and/or measuring a 3D geometry of at least a part of a surface of an object, said scanner comprising:
- 25 - a first camera comprising an array of sensor elements,
- a first means for generating a probe light,
- means for transmitting the probe light rays towards the object thereby illuminating at least a part of the object,
- means for transmitting light rays returned from the object to the array of
30 sensor elements,

- a first optical system for imaging with a first depth of field on the first camera at least part of the transmitted light rays returned from the object to the array of sensor elements,
 - means for varying the position of the focus plane on the object,
 - 5 - means for obtaining at least one image from said array of sensor elements,
 - means for determining the in-focus position(s) of:
 - each of a plurality of the sensor elements for a range of focus plane positions, or
 - each of a plurality of groups of the sensor elements
 - 10 for a range of focus plane positions, and
 - means for transforming the in-focus data into 3D coordinates;
 - means for selecting a portion of light rays returned from the object, where the light rays have been transmitted through at least a part of the first optical system; and
 - 15 - a second camera for capturing at least some of the selected light rays with a second depth of field which is substantially larger than the first depth of field.
3. The scanner according to any one or more of the preceding claims, wherein the second camera is adapted for forming at least one image in 1D and/or 2D of at least some of the selected light rays.
4. The scanner according to any one or more of the preceding claims, wherein the second depth of field image has a fixed perspective relative to the perspective of the first depth of field image(s).
- 25
5. The scanner according to any one or more of the preceding claims, wherein the second depth of field image has substantially the same perspective as the first depth of field image(s).

6. The scanner according to any one or more of the preceding claims, wherein the second depth of field image is substantially unaffected by varying the position of the focus plane on the object.
- 5 7. The scanner according to any one or more of the preceding claims, wherein the means for selecting a portion of light rays returned from the object is arranged in an aperture in the first optical system.
- 10 8. The scanner according to any one or more of the preceding claims, wherein the means for selecting a portion of light rays is arranged between the first optical system and focusing optics of the scanner.
- 15 9. The scanner according to any one or more of the preceding claims, wherein the means for selecting a portion of light rays is a second optical element arranged in the aperture to select light rays from a region of the aperture for obtaining the second depth of field image(s).
- 20 10. The scanner according to any one or more of the preceding claims, wherein the region of the aperture, where light rays is selected from, is small relative to the total area of the aperture, such as less than 50% of the area of the aperture, such as less than about 40% of the area of the aperture, such as less than about 30% of the area of the aperture, such as less than about 20% of the area of the aperture, such as less than about 10% of the area of the aperture, such as less than about 5% of the area of the aperture, such as less than about 2% of the area of the aperture, such as less than about 1% of the area of the aperture.
- 25 11. The scanner according to any one or more of the preceding claims, wherein the selected light rays are deflected in a different direction than the direction of the first optical system.
- 30

12. The scanner according to any one or more of the preceding claims, wherein the deflected rays are directed to a second optical system for imaging onto the second camera.
- 5 13. The scanner according to any one or more of the preceding claims, wherein the first camera and the second camera are adapted to operate simultaneously.
- 10 14. The scanner according to any one or more of the preceding claims, wherein the second optical element in the aperture is a mirror.
- 15 15. The scanner according to any one or more of the preceding claims, wherein the second optical element in the aperture is a beam splitter.
- 15 16. The scanner according to any one or more of the preceding claims, wherein the second optical element in the aperture is a filter adapted to select light rays of one or more specific wavelengths.
- 20 17. The scanner according to any one or more of the preceding claims, wherein the second optical element in the aperture is small relative to the total area of the aperture, such as less than 50% of the area of the aperture, such as less than about 40% of the area of the aperture, such as less than about 30% of the area of the aperture, such as less than about 20% of the area of the aperture, such as less than about 10% of the area of the aperture, such as less than about 5% of the area of the aperture, such as less than about 2% of the area of the aperture, such as less than about 1% of the area of the aperture.
- 25 18. The scanner according to any one or more of the preceding claims, wherein the first optical element is configured to switch between selecting
- 30

substantially all light rays impinging the aperture and only selecting a portion of the light rays impinging the aperture.

5 19. The scanner according to any one or more of the preceding claims, wherein the selected portion of light rays impinging on the aperture is small relative to all the light rays impinging the aperture, such as less than 50% of all light rays, such as less than about 40% of all light rays, such as less than about 30% of all light rays, such as less than about 20% of all light rays, such as less than about 10% of all light rays, such as less than about 5% of all
10 light rays, such as less than about 2% of all light rays, such as less than about 1% of all light rays.

15 20. The scanner according to any one or more of the preceding claims, wherein the first optical element configured to switch comprises a liquid crystal.

20 21. The scanner according to any one or more of the preceding claims, wherein the first optical element and/or the second optical element is configured for controlling the polarization of the light rays.

22. The scanner according to any one or more of the preceding claims, wherein means for polarizing the light rays is arranged in front of the first means for generating a probe light and/or in front of the second camera.

25 23. The scanner according to any one or more of the preceding claims, wherein the probe light is substantially white light.

30 24. The scanner according to any one or more of the preceding claims, wherein the scanner comprises a second means for generating a probe light which is not used for determining the in-focus positions.

25. The scanner according to any one or more of the preceding claims, wherein the second means for generating a probe light generates white light.
26. The scanner according to any one or more of the preceding claims,
5 wherein the second camera is a color camera.
27. The scanner according to any one or more of the preceding claims, wherein the color camera comprises a 2D array of photo sensors and a color filter array.
10
28. The scanner according to any one or more of the preceding claims, wherein the color filter array is a Bayer filter array.
29. The scanner according to any one or more of the preceding claims,
15 wherein the color filter array comprises more than three filters.
30. The scanner according to any one or more of the preceding claims, wherein the color camera comprises a trichroic beam splitter and three different sensors to obtain images of the individual colors.
20
31. The scanner according to any one or more of the preceding claims, wherein the color of the probe light generated by the second means is adapted to be changed.
- 25 32. The scanner according to any one or more of the preceding claims, wherein the second means for generating probe light is LEDs of different colors.
- 30 33. The scanner according to any one or more of the preceding claims, wherein the differently colored LEDs are adapted to be activated at different times, and whereby black and white images are adapted to be recorded with

the second camera, and where the black and images are adapted to be combined to a full-color image.

34. A scanner for obtaining and/or measuring a 3D geometry of at least a part of a surface of an object, said scanner comprising:
- 5 - a first camera comprising an array of sensor elements,
 - a first means for generating a probe light,
 - means for transmitting the probe light rays towards the object thereby illuminating at least a part of the object,
 - 10 - means for transmitting light rays returned from the object to the array of sensor elements,
 - a first optical system for imaging with a first depth of field on the first camera at least part of the transmitted light rays returned from the object to the array of sensor elements,
 - 15 - means for varying the position of the focus plane on the object,
 - means for obtaining at least one image from said array of sensor elements,
 - means for determining the in-focus position(s) of:
 - each of a plurality of the sensor elements for a range of focus plane positions, or
 - 20 - each of a plurality of groups of the sensor elements for a range of focus plane positions, and
 - means for transforming the in-focus data into 3D coordinates;
- wherein the scanner further comprises a color measuring probe rigidly attached to the 3D scanner.

25

35. The scanner according to any one or more of the preceding claims, wherein the color measuring probe is a probe suitable for measuring tooth shades.

36. The scanner according to any one or more of the preceding claims, wherein the color measuring probe is configured to perform the measurement in at least one point on a tooth.
- 5 37. The scanner according to any one or more of the preceding claims, wherein the position of the point measurement and/or the orientation of the color measurement probe relative to the object is derivable due to the rigid attachment of the color measuring probe relative to the scanner.
- 10 38. The scanner according to any one or more of the preceding claims, wherein the color measuring probe is adapted to be arranged perpendicular to a surface of the object.
39. The scanner according to any one or more of the preceding claims, wherein the color measuring probe is a spectrophotometer system
- 15 comprising:
- a probe tip including one or more light sources and a plurality of light receivers;
 - a first spectrometer system receiving light from a first set of the plurality of light receivers;
 - 20 - a second spectrometer system receiving light from a second set of the plurality of light receivers;
 - a processor, wherein the processor receives data generated by the first spectrometer system and the second spectrometer system,
- wherein an optical measurement of the object is produced based on the data
- 25 generated by the first and second spectrometer systems.
40. The scanner according to any one or more of the preceding claims, wherein the color measuring probe is for determining optical characteristics of a translucent dental tooth, comprising:
- 30 - a probe with a tip adapted to provide light to a surface of the tooth from at

- least one light source, and to receive light from the tooth through at least one light receiver, the at least one light source and the at least one light receiver being spaced apart to define a minimal height as a predetermined distance from the surface below which no light from the at least one light source that is specularly reflected from said surface is received by the at least one light receiver,
- 5
- light sensors coupled to the at least one light receiver for determining the intensity of light received by the light receiver, when the probe is at a point away from the surface of the tooth but less than the minimal height; and
- 10
- a computing device coupled to the light sensors.

41. A scanner for obtaining and/or measuring a 3D geometry of at least a part of a surface of an object, said scanner comprising:
- a first camera comprising an array of sensor elements,
- 15
- a first means for generating a probe light,
 - means for transmitting the probe light rays towards the object thereby illuminating at least a part of the object,
 - means for transmitting light rays returned from the object to the array of sensor elements,
- 20
- a first optical system for imaging with a first depth of field on the first camera at least part of the transmitted light rays returned from the object to the array of sensor elements,
 - means for varying the position of the focus plane on the object,
 - means for obtaining at least one image from said array of sensor elements,
- 25
- means for determining the in-focus position(s) of:
 - each of a plurality of the sensor elements for a range of focus plane positions, or
 - each of a plurality of groups of the sensor elements for a range of focus plane positions, and
- 30
- means for transforming the in-focus data into 3D coordinates;

wherein the scanner further comprises at least one reflective optical element arranged in the scanner such that the reflective optical element provides for that at least two different perspective views on the acquired images is obtainable without performing movement of the scanner.

5

42. The scanner according to any one or more of the preceding claims, wherein a first set of images with a first perspective view and a second set of images with a second perspective view are acquired simultaneously or concurrently.

10

43. The scanner according to any one or more of the preceding claims, wherein the first perspective view is fixed relative to the second perspective view.

15

44. The scanner according to any one or more of the preceding claims, wherein the scanner comprises means for switching between different perspective views of the images.

20

45. The scanner according to any one or more of the preceding claims, wherein the scanner comprises means for combining images with different perspective views acquired.

25

46. The scanner according to any one or more of the preceding claims, wherein the at least one reflective optical element is arranged in the tip of the scanner which is configured for pointing towards the object to be scanned.

30

47. The scanner according to any one or more of the preceding claims, wherein the at least one reflective optical element comprises two dichroic mirrors or filters.

48. The scanner according to any one or more of the preceding claims, wherein the at least one reflective optical element comprises a multi-facet mirror.

5 49. The scanner according to any one or more of the preceding claims, wherein the at least one reflective optical element comprises a digital light processing (DLP).

10 50. The scanner according to any one or more of the preceding claims, wherein the at least one reflective optical element and/or the other optical elements is/are adapted to generate one or more patterns to be imaged on the object while scanning.

15 51. The scanner according to any one or more of the preceding claims, wherein the tip of the scanner is exchangeable, and where at least two different tips are adapted to fit on the scanner, where one of the tips comprises one or more mirrors arranged at about 38 degrees relative to an axis perpendicular to the optical axis, and where another of the tips comprises one or more mirrors arranged at about 45 degrees relative to an
20 axis perpendicular to the optical axis.

52. A scanner for obtaining and/or measuring a 3D geometry of at least a part of a surface of an object, said scanner comprising:
- a first camera comprising an array of sensor elements,
25 - a first means for generating a probe light,
- means for transmitting the probe light rays towards the object thereby illuminating at least a part of the object,
- means for transmitting light rays returned from the object to the array of sensor elements,

- a first optical system for imaging with a first depth of field on the first camera at least part of the transmitted light rays returned from the object to the array of sensor elements,
- means for varying the position of the focus plane on the object,
- 5 - means for obtaining at least one image from said array of sensor elements,
- means for determining the in-focus position(s) of:
 - each of a plurality of the sensor elements for a range of focus plane positions, or
 - each of a plurality of groups of the sensor elements
 - 10 for a range of focus plane positions, and
- means for transforming the in-focus data into 3D coordinates;
wherein the scanner further comprises means for performing spectral analysis of the light returned from the object.
- 15 53. The scanner according to any one or more of the preceding claims, wherein the means for performing spectral analysis is in a 1D array.
- 54. The scanner according to any one or more of the preceding claims, wherein the points in the 1D image are spectrally analyzed.
- 20 55. The scanner according to any one or more of the preceding claims,, wherein the 1D spectral analysis is performed on the second camera comprising a 2D array, where one axis of the camera array corresponds to a spatial coordinate on the object being scanned and the other axis of the camera array corresponds to a wavelength coordinate of the light returned
- 25 from the object.
- 56. The scanner according to any one or more of the preceding claims, wherein the spectrally analyzed light is a portion of light rays returned from
- 30 the object and transmitted through at least a part of the first optical system.

57. The scanner according to any one or more of the preceding claims, wherein the spectral analysis is performed by means of a diffractive optical component.
- 5 58. The scanner according to any one or more of the preceding claims, wherein the diffractive optical component is a grating.
59. The scanner according to any one or more of the preceding claims, wherein the spectral analysis is performed by means of a prism.
- 10 60. The scanner according to any one or more of the preceding claims, wherein the spectral analysis is performed by means of a color gradient film.
61. The scanner according to any one or more of the preceding claims, wherein the 3D scanning is an intra oral scanning of at least part of the patient's set of teeth, a scan of at least part of an impression of the patient's set of teeth, and/or a scan of at least part of a model of the patient's set of teeth.
- 15 62. An optical system for obtaining and/or measuring a 3D geometry of at least a part of a surface of an object, said optical system comprising:
- a first camera comprising an array of sensor elements,
 - a first means for generating a probe light,
 - means for transmitting the probe light rays towards the object thereby
 - 25 illuminating at least a part of the object,
 - means for transmitting light rays returned from the object to the array of sensor elements,
 - a first optical system for imaging with a first depth of field on the first camera at least part of the transmitted light rays returned from the object to the array
 - 30 of sensor elements,
 - means for varying the position of the focus plane on the object,

- means for obtaining at least one image from said array of sensor elements,
 - means for determining the in-focus position(s) of:
 - each of a plurality of the sensor elements for a range of focus plane positions, or
 - 5 - each of a plurality of groups of the sensor elements for a range of focus plane positions, and
 - means for transforming the in-focus data into 3D coordinates.
- 10 63. A scanner for obtaining and/or measuring a 3D geometry of at least a part of a surface of an object, said scanner comprising:
- a light first source configured for generating a probe light;
 - 15 - a first camera comprising an array of sensor elements, where said camera is configured for obtaining at least one image from said array of sensor elements;
 - an arrangement of optical components configured for
 - 20 transmitting the probe light rays towards the object such that at least a part of the object can be illuminated;
 - transmitting light rays returned from the object to the array of sensor elements; and
 - imaging with a first depth of field at least part of the transmitted light rays
 - 25 returned from the object onto the array of sensor elements;
- where the arrangement of optical components comprises focusing optics that defines a focus plane for the scanner,

- a positioning device configured for varying the position of the focusing optics, such that the position of the focus plane relative to the scanner is changed,
- 5 - a data processing device, configured for determining the in-focus position(s) of:
 - each of a plurality of the sensor elements for a range of focus plane positions, or
 - each of a plurality of groups of the sensor elements for a range of
 - 10 focus plane positions,and for transforming the in-focus data into 3D coordinates.

64. The scanner according claim 63, wherein the scanner comprises:
- 15 - optics for selecting a portion of light rays returned from the object, where the light rays have been transmitted through at least a part of the first optical system; and
 - a second camera arranged to capture at least some of the selected light rays, where the second camera is configured for obtaining a second depth of
 - 20 field image with a second depth of field which is substantially larger than the first depth of field.

65. The scanner according to any one or more of the preceding claims, wherein the ratio between the second depth of field and the depth of a scan
- 25 volume of the scanner is in the range of about 0.1 to about 10, such as in the range of about 0.2 to about 5, such as in the range of about 0.25 to about 4, such as in the range of about 0.4 to about 2.5, such as in the range of about 0.5 to about 2, such as in the range of about 0.7 to about 1.5, such as in the range of about 0.8 to about 1.25, such as in the range of about 0.9 to about
 - 30 1.1.

66. A method for obtaining and/or measuring a 3D geometry of at least a part of a surface of an object, said method comprising :
- generating a probe light by means of a first means for generating probe light,
 - 5 - transmitting the probe light rays towards the object thereby illuminating at least a part of the object,
 - transmitting light rays returned from the object to an array of sensor elements in a first camera,
 - imaging with a first depth of field on the first camera at least part of the
 - 10 transmitted light rays returned from the object to the array of sensor elements by means of a first optical system,
 - varying the position of the focus plane on the object,
 - obtaining at least one image from said array of sensor elements,
 - determining the in-focus position(s) of:
 - 15
 - each of a plurality of the sensor elements for a range of focus plane positions, or
 - each of a plurality of groups of the sensor elements for a range of focus plane positions, and
 - transforming the in-focus data into 3D coordinates.
 - 20

67. A method a method for obtaining and/or measuring a 3D geometry of at least a part of a surface of an object, said method comprising :
- generating a probe light by means of a first means for generating probe
 - 25 light,
 - transmitting the probe light rays towards the object thereby illuminating at least a part of the object,
 - transmitting light rays returned from the object to an array of sensor elements in a first camera,

- imaging with a first depth of field on the first camera at least part of the transmitted light rays returned from the object to the array of sensor elements by means of a first optical system,
- varying the position of the focus plane on the object,
- 5 - obtaining at least one image from said array of sensor elements,
- determining the in-focus position(s) of:
 - each of a plurality of the sensor elements for a range of focus plane positions, or
 - each of a plurality of groups of the sensor elements
 - 10 for a range of focus plane positions, and
- transforming the in-focus data into 3D coordinates,
- selecting a portion of light rays returned from the object, where the light rays have been transmitted through at least a part of the first optical system; and
- capturing at least some of the selected light rays with a second depth of
- 15 field substantially larger than the first depth of field by means of a second camera.

68. A method for obtaining and/or measuring a 3D geometry of at least a part of a surface of an object, said method comprising :

- 20 - generating a probe light by means of a first means for generating probe light,
- transmitting the probe light rays towards the object thereby illuminating at least a part of the object,
- transmitting light rays returned from the object to an array of sensor
- 25 elements in a first camera,
- imaging with a first depth of field on the first camera at least part of the transmitted light rays returned from the object to the array of sensor elements by means of a first optical system,
- varying the position of the focus plane on the object,
- 30 - obtaining at least one image from said array of sensor elements,
- determining the in-focus position(s) of:

- each of a plurality of the sensor elements for a range of focus plane positions, or
 - each of a plurality of groups of the sensor elements for a range of focus plane positions, and
- 5 - transforming the in-focus data into 3D coordinates, wherein the method further comprises performing spectral analysis of the light returned from the object.
- 10 69. A method for obtaining and/or measuring a 3D geometry of at least a part of a surface of an object, said method comprising :
- generating a probe light by means of a first means for generating probe light,
 - transmitting the probe light rays towards the object thereby illuminating at
- 15 least a part of the object,
- transmitting light rays returned from the object to an array of sensor elements in a first camera,
 - imaging with a first depth of field on the first camera at least part of the transmitted light rays returned from the object to the array of sensor elements
- 20 by means of a first optical system,
- varying the position of the focus plane on the object,
 - obtaining at least one image from said array of sensor elements,
 - determining the in-focus position(s) of:
- each of a plurality of the sensor elements for a
- 25 range of focus plane positions, or
- each of a plurality of groups of the sensor elements for a range of focus plane positions, and
- transforming the in-focus data into 3D coordinates,
- wherein the method further comprises performing a color measurement by
- 30 means of a color measuring probe rigidly attached to the 3D scanner.

70. A method for obtaining and/or measuring a 3D geometry of at least a part of a surface of an object, said method comprising :
- generating a probe light by means of a first means for generating probe light,
 - 5 - transmitting the probe light rays towards the object thereby illuminating at least a part of the object,
 - transmitting light rays returned from the object to an array of sensor elements in a first camera,
 - imaging with a first depth of field on the first camera at least part of the transmitted light rays returned from the object to the array of sensor elements
 - 10 by means of a first optical system,
 - varying the position of the focus plane on the object,
 - obtaining at least one image from said array of sensor elements,
 - determining the in-focus position(s) of:
 - 15
 - each of a plurality of the sensor elements for a range of focus plane positions, or
 - each of a plurality of groups of the sensor elements for a range of focus plane positions, and
 - transforming the in-focus data into 3D coordinates,
 - 20 wherein the method further comprises providing that at least two different perspective views on the acquired images is obtainable without performing movement of the scanner by means of at least one reflective optical element arranged in the scanner.
 - 25
71. A computer program product comprising program code means for causing a data processing system to perform the method of any one or more of claims 63-67, when said program code means are executed on the data processing system.
- 30

72. A computer program product according to the previous claim, comprising a computer-readable medium having stored there on the program code means.

Prior art

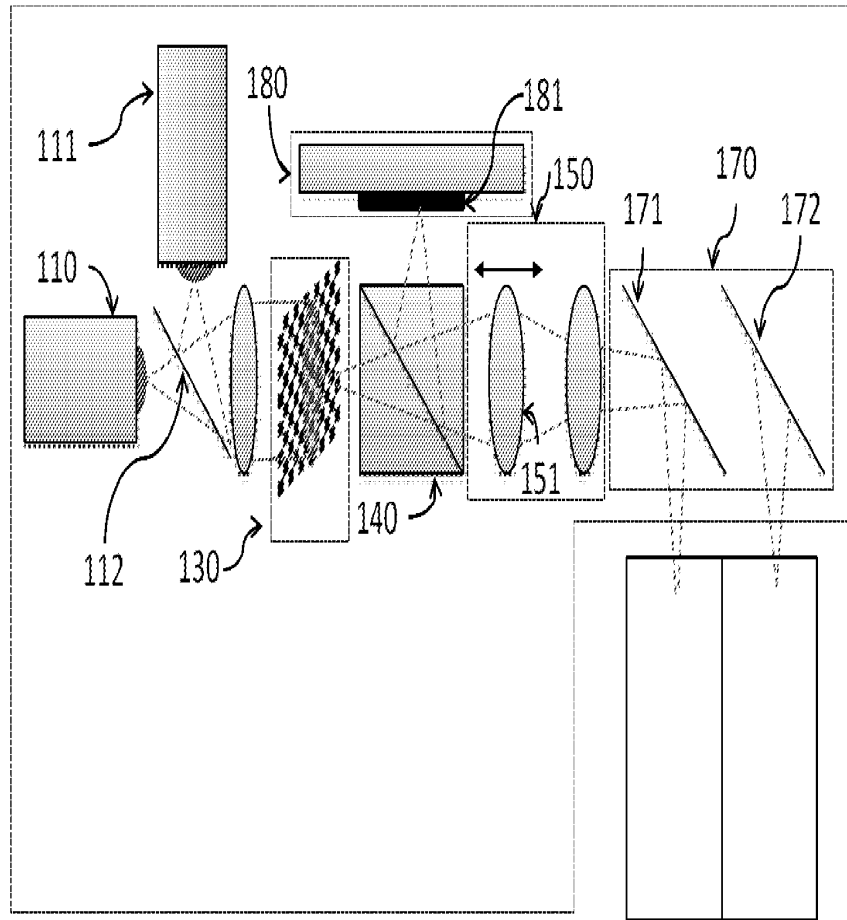

Fig. 1

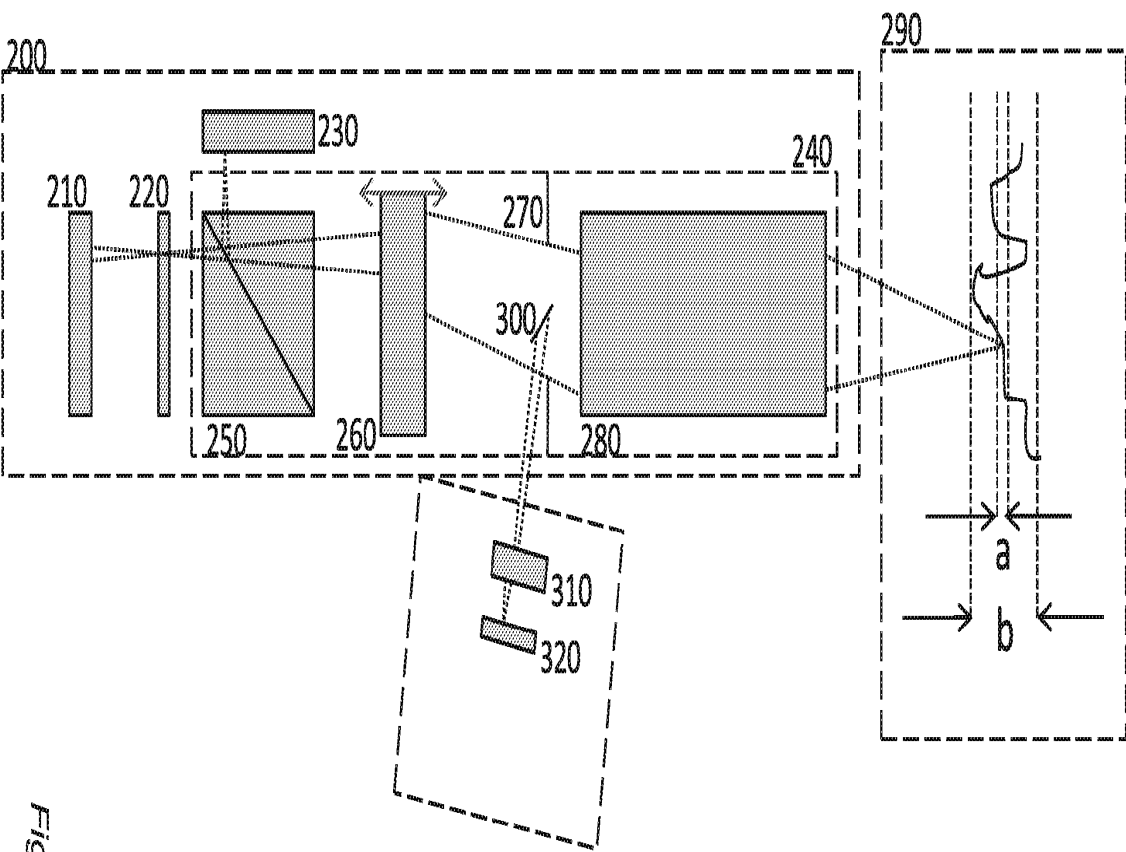

Fig. 2

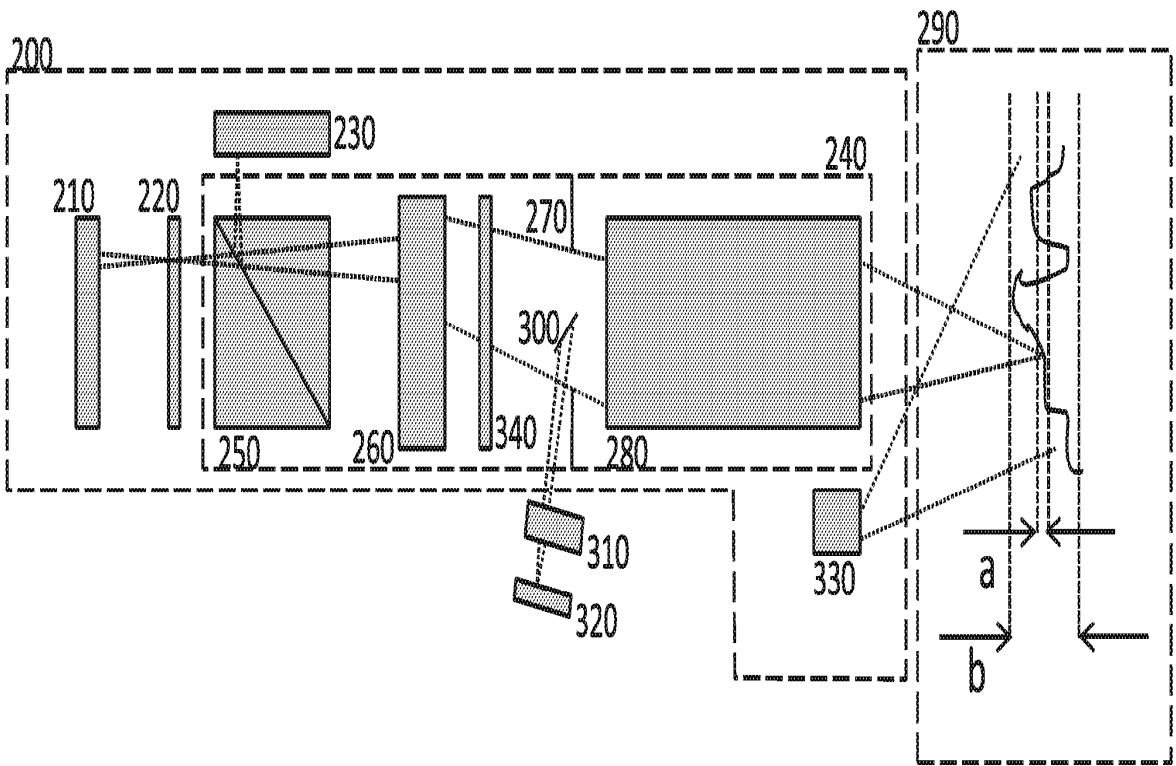
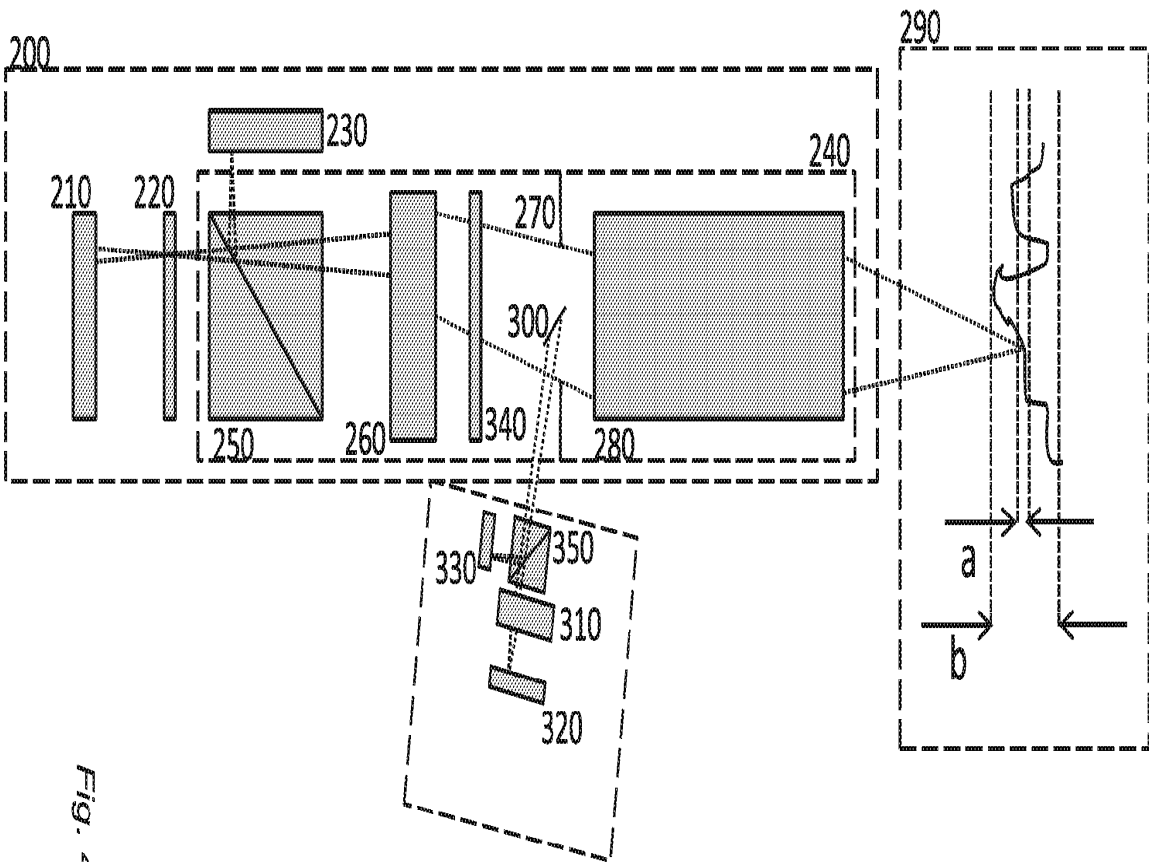

Fig. 3



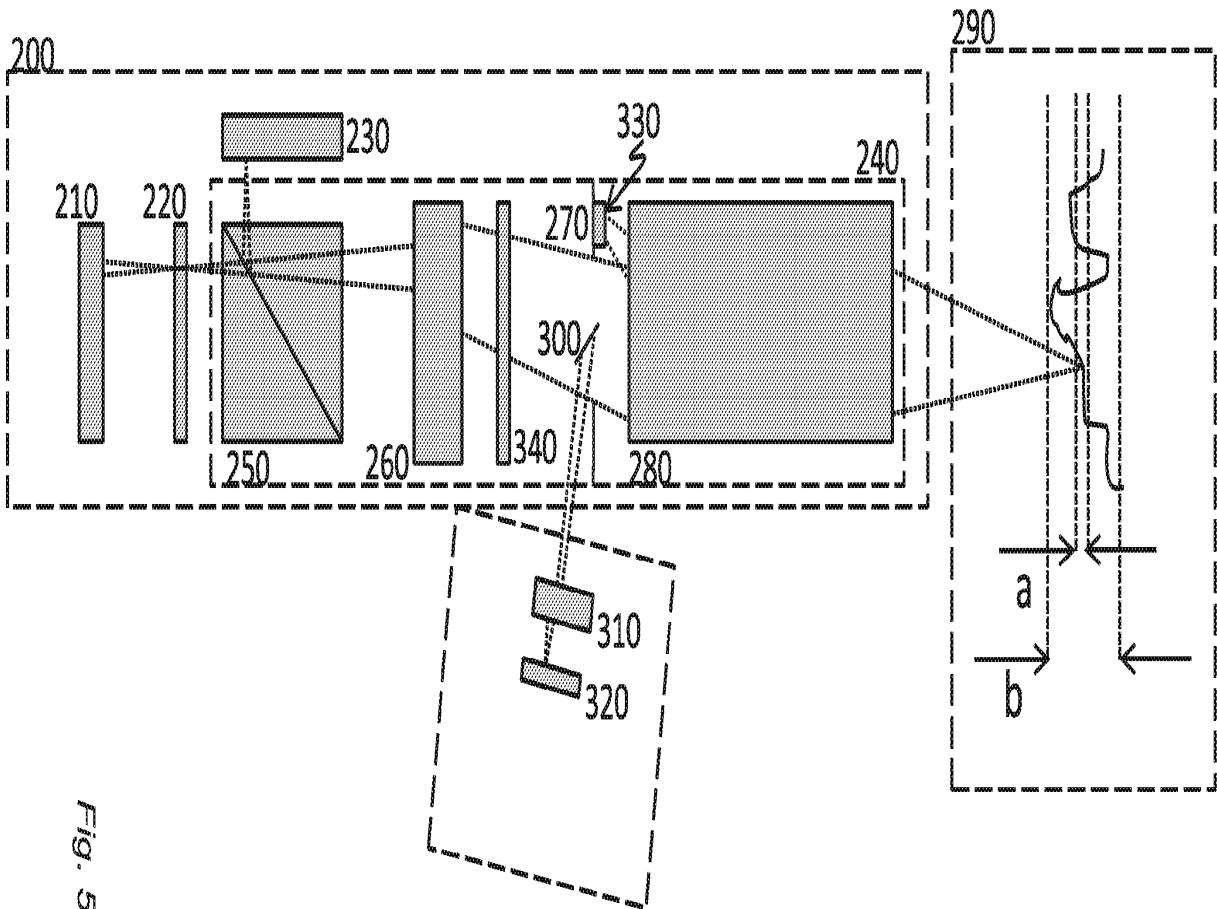

Fig. 5

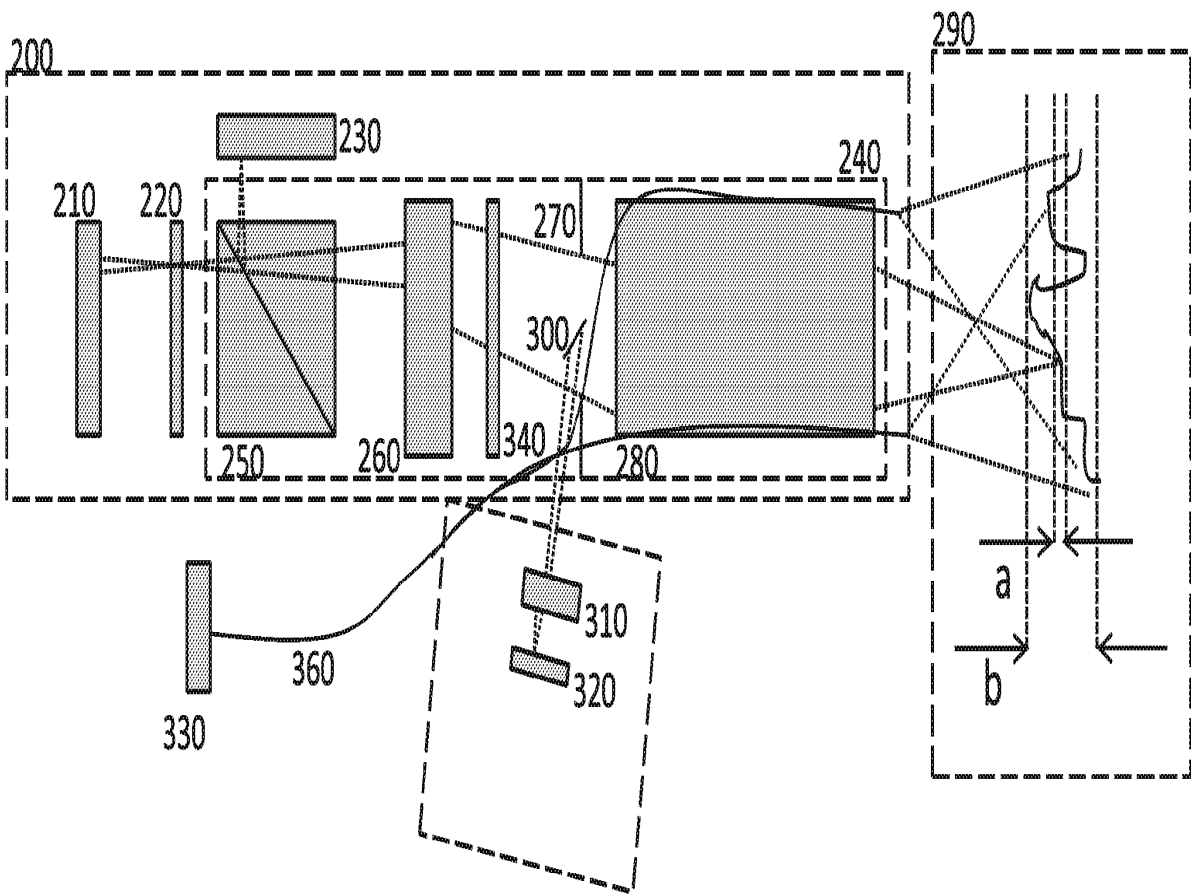

Fig. 6

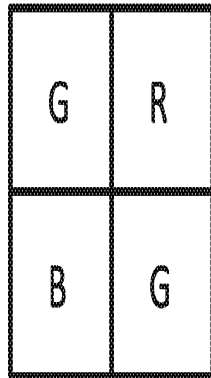

Fig. 7a

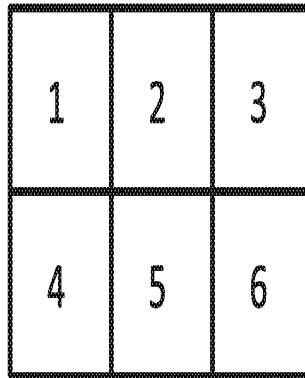
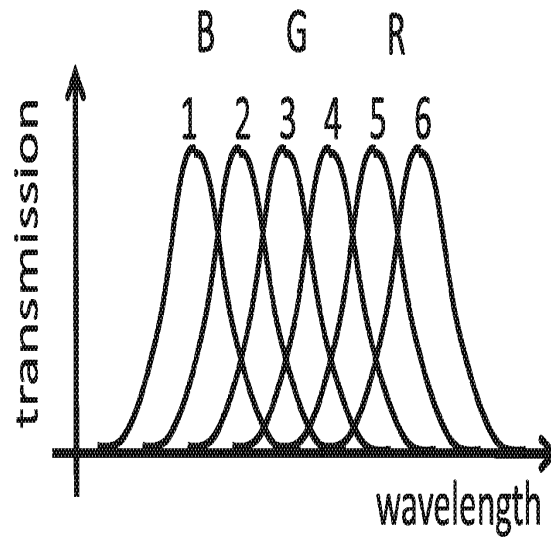

Fig. 7b

Fig. 7

Fig. 7c



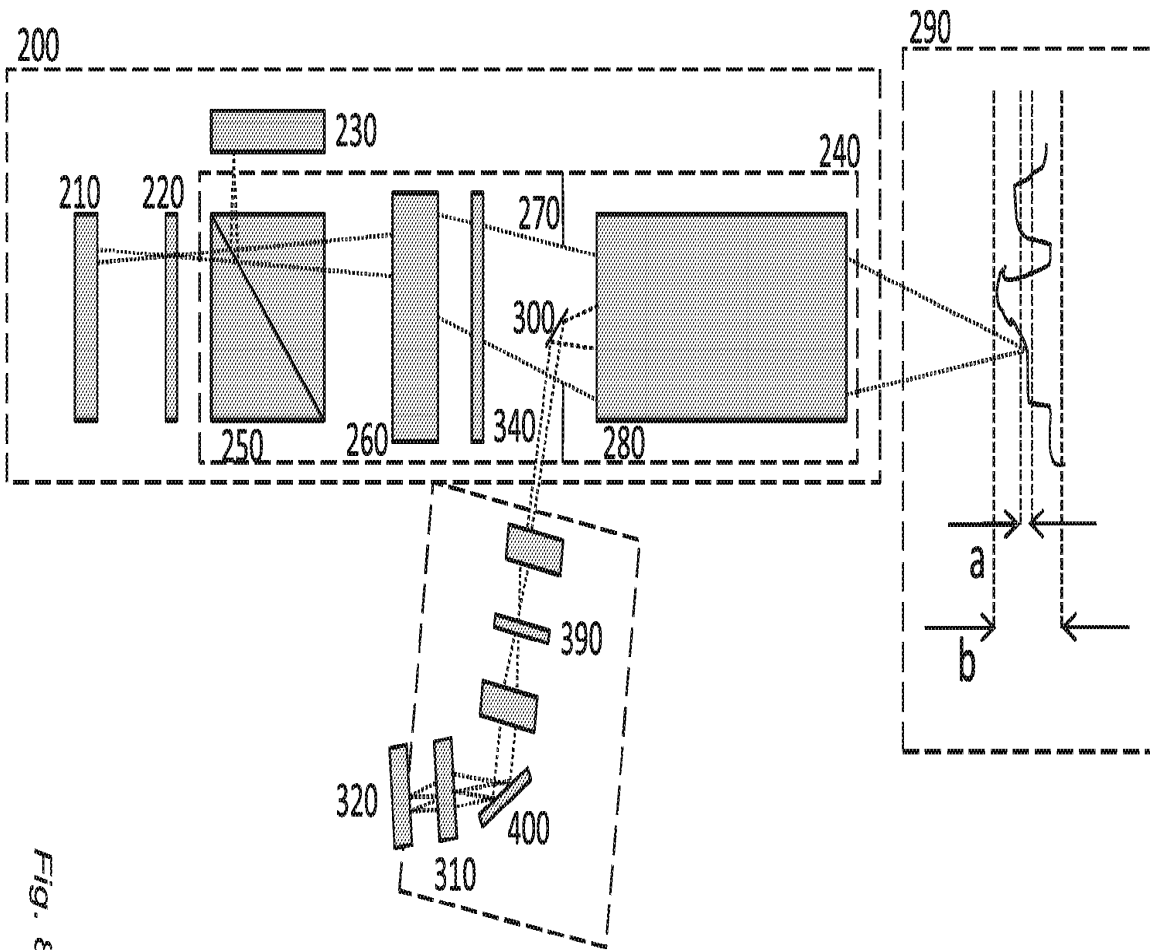
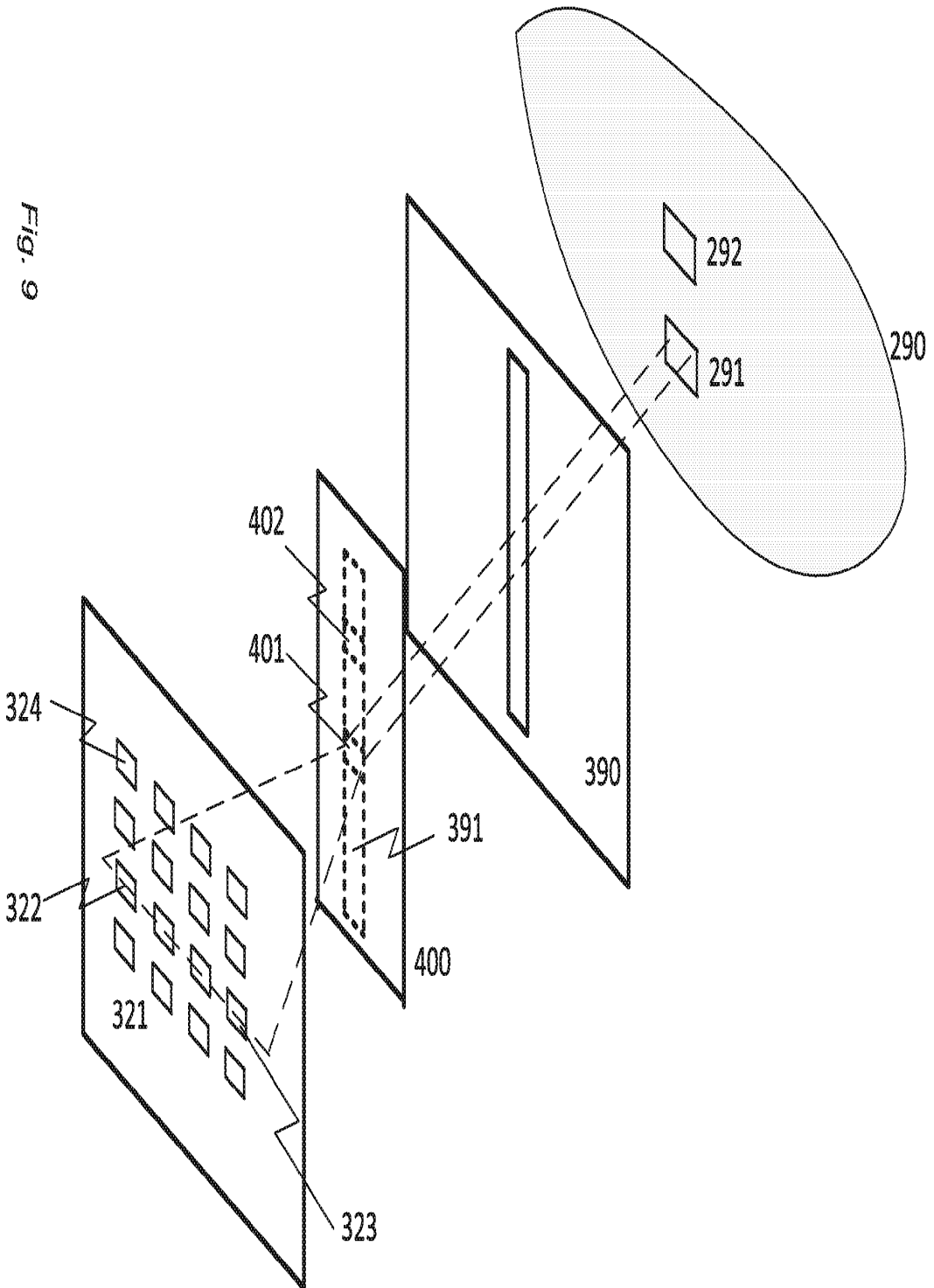

Fig. 8



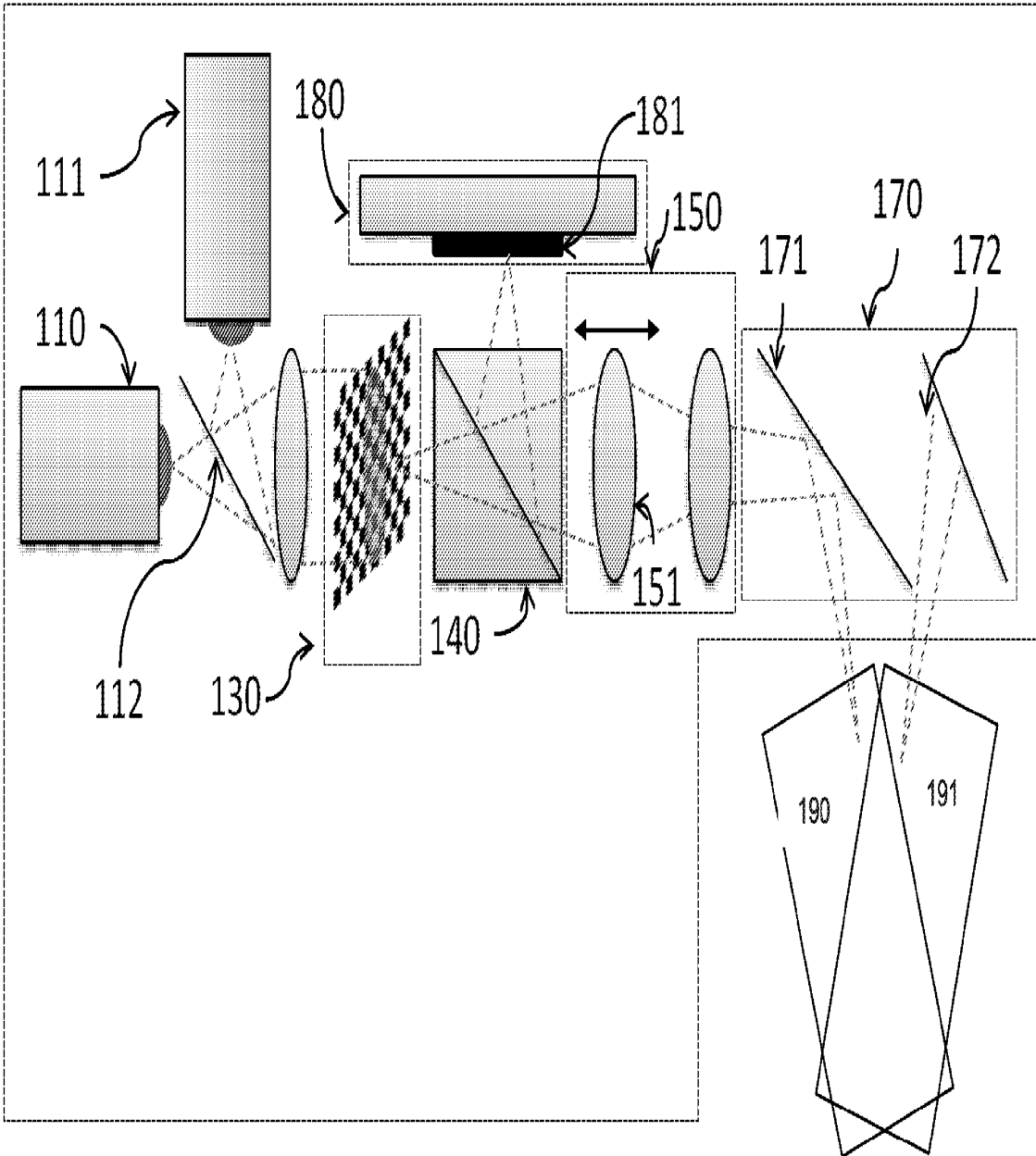

Fig. 10

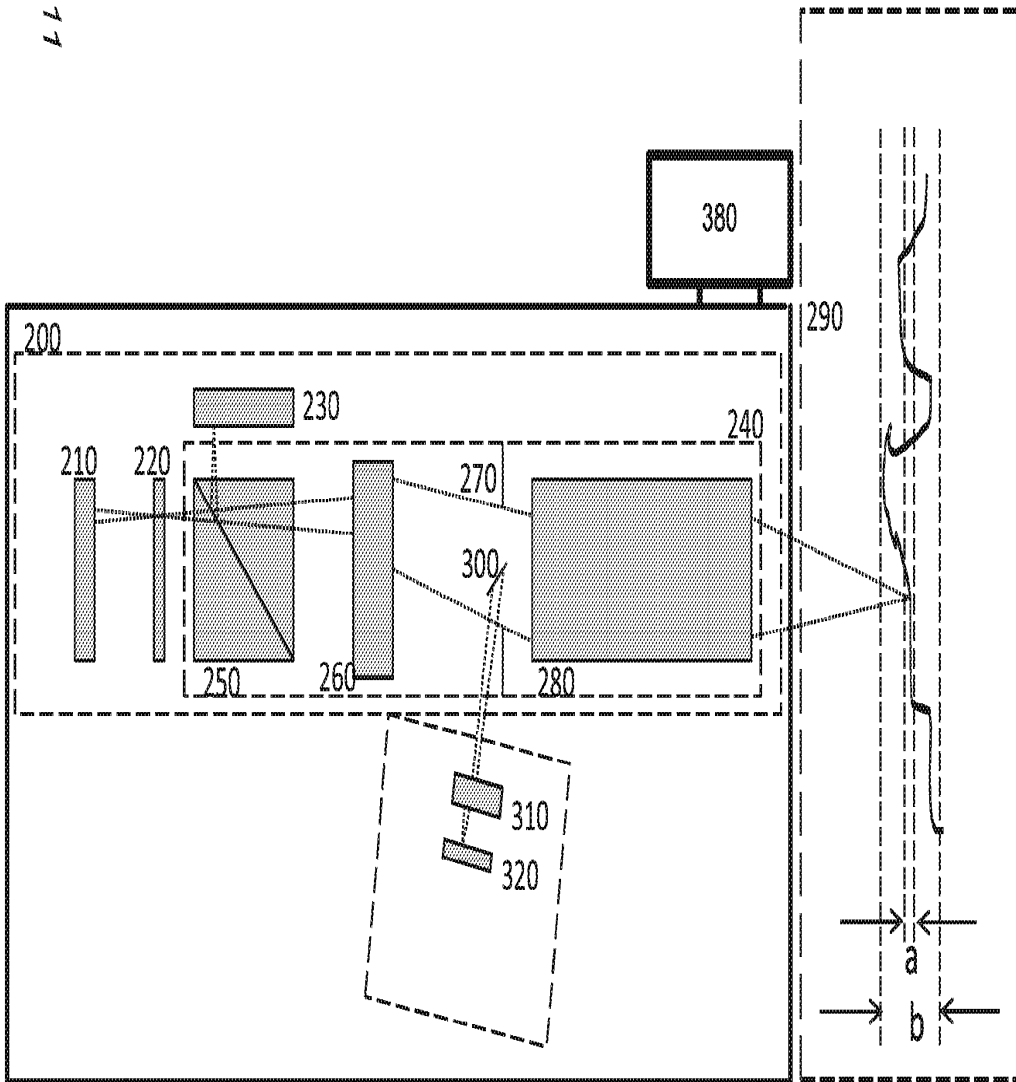

Fig. 11

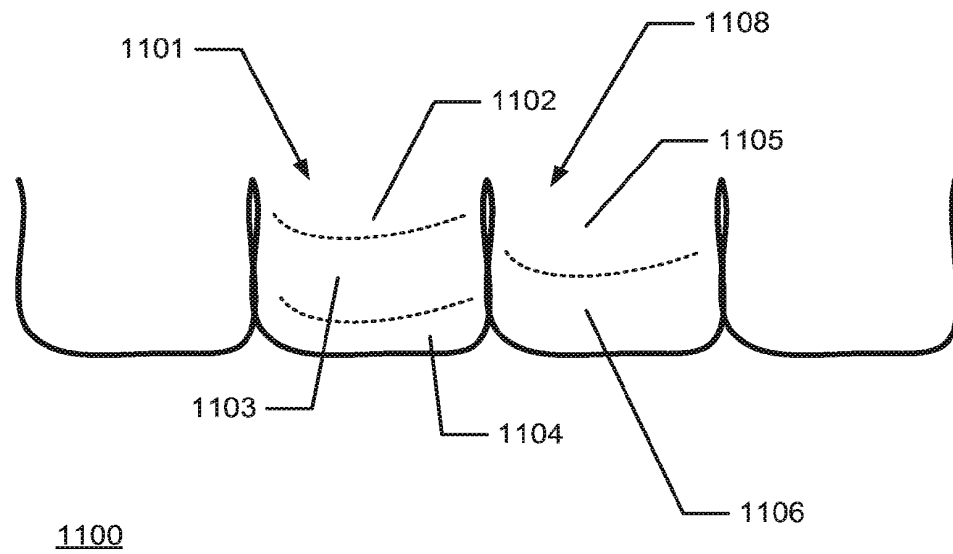

Fig. 12

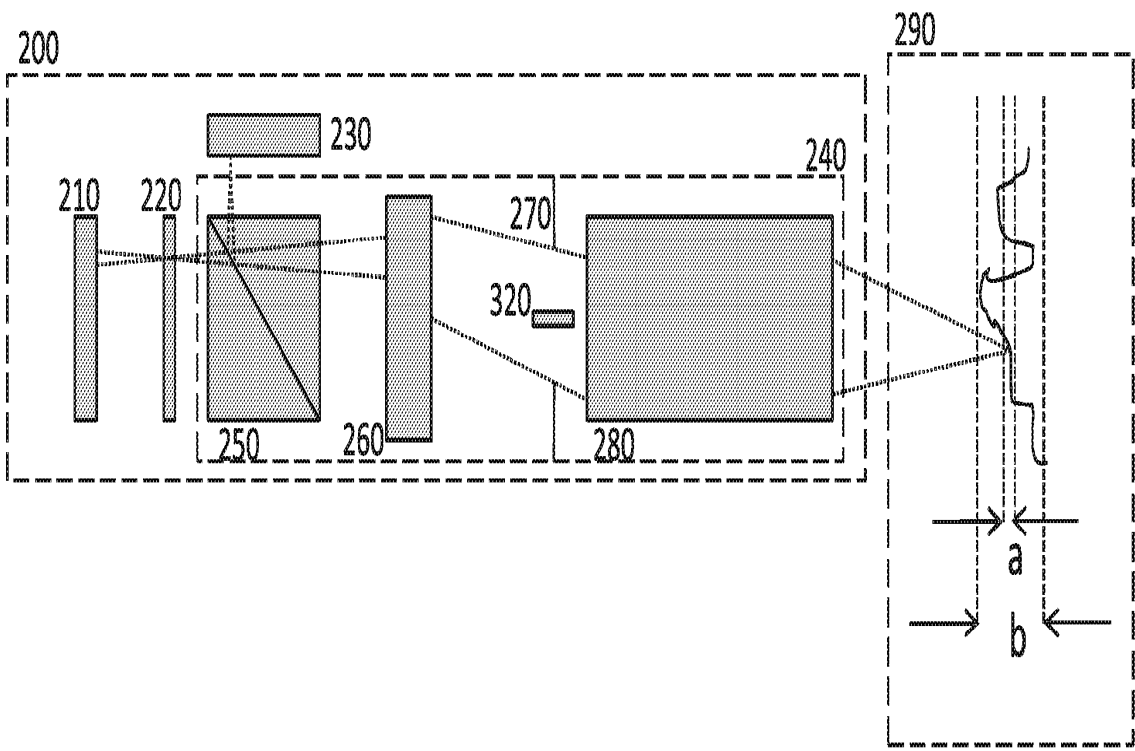

Fig. 13

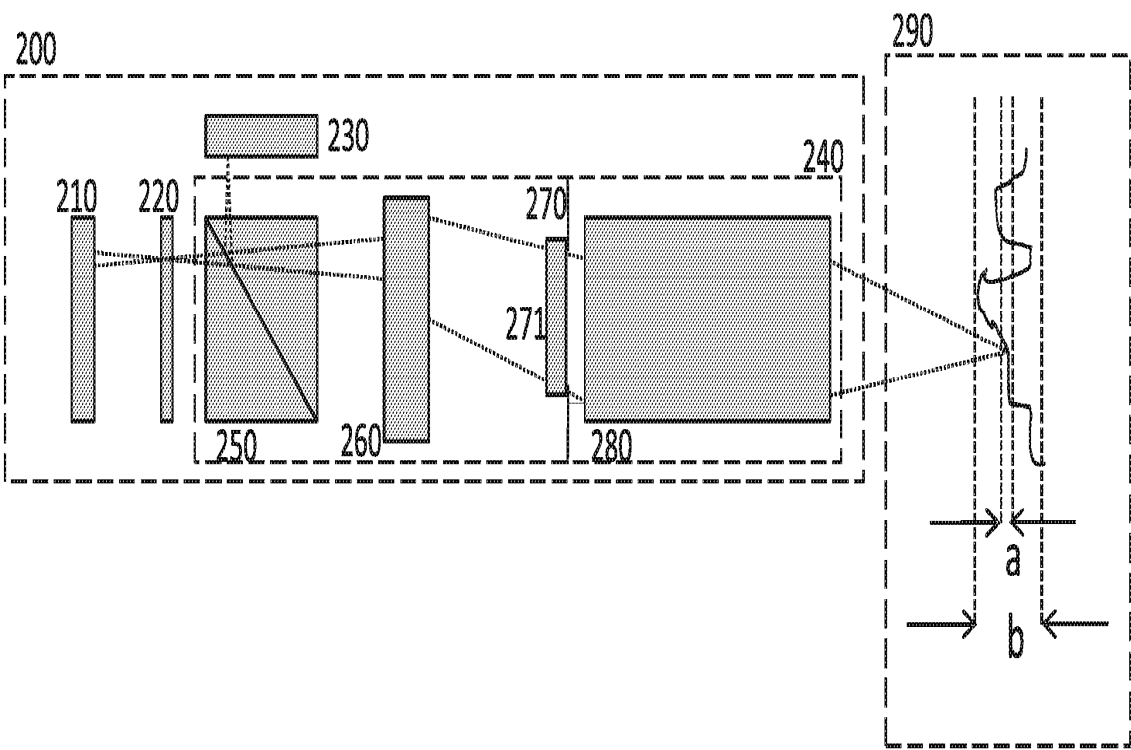

Fig. 14

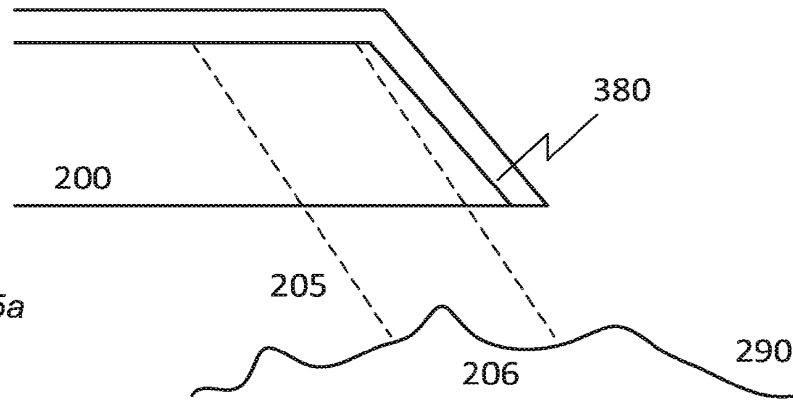

Fig. 15a

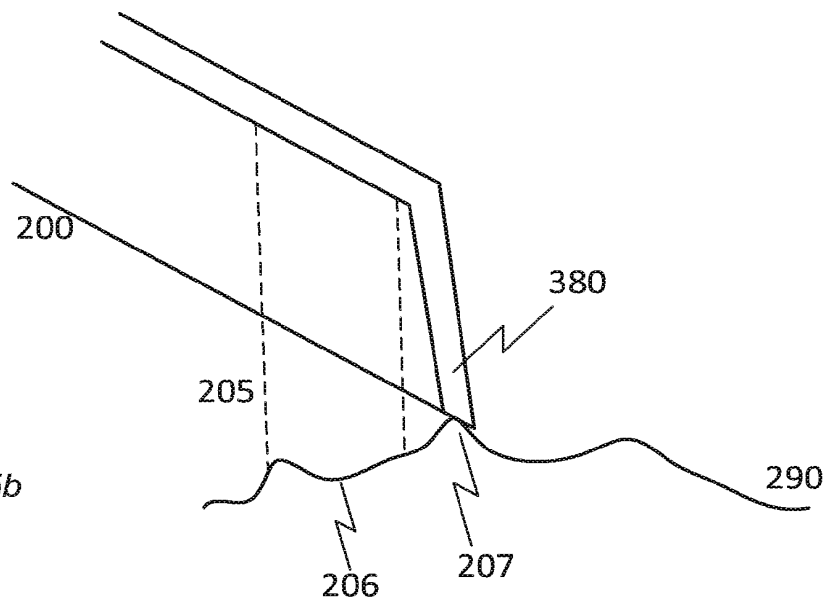

Fig. 15b

INTERNATIONAL SEARCH REPORT

International application No.
PCT/DK2011/050507

A. CLASSIFICATION OF SUBJECT MATTER A61C13/00 (2006.01), A61B5/107 (2006.01)		
According to International Patent Classification (IPC) or to both national classification and IPC		
B. FIELDS SEARCHED		
Minimum documentation searched (classification system followed by classification symbols) ECLA, IPC: A61C, A61B, G03B		
Documentation searched other than minimum documentation to the extent that such documents are included in the fields searched		
Electronic data base consulted during the international search (name of data base and, where practicable, search terms used) EPODOC, WPI, TXTE		
C. DOCUMENTS CONSIDERED TO BE RELEVANT		
Category*	Citation of document, with indication, where appropriate, of the relevant passages	Relevant to claim No.
X	EP 1941843 A2 (CADENT LTD) 09.07.2008, sec [0001], [0010]-[0011], [0016], [0019], [0023], [0097], [0111]-[0112], fig. 13.	1, 34, 62-63, 66, 69, 71-72
X, E	WO 2010/145669 A1 (FISKER et al) 23.12.2010, page 3, line 1-26.	1, 62-63, 66
A	US 2009/0079861 A1 (LIAO) 26.03.2009, figure 2.	
<input type="checkbox"/> Further documents are listed in the continuation of Box C. <input checked="" type="checkbox"/> See patent family annex.		
* Special categories of cited documents: "A" document defining the general state of the art which is not considered to be of particular relevance "E" earlier application or patent but published on or after the international filing date "L" document which may throw doubts on priority claim(s) or which is cited to establish the publication date of another citation or other special reason (as specified) "O" document referring to an oral disclosure, use, exhibition or other means "P" document published prior to the international filing date but later than the priority date claimed "T" later document published after the international filing date or priority date and not in conflict with the application but cited to understand the principle or theory underlying the invention "X" document of particular relevance; the claimed invention cannot be considered novel or cannot be considered to involve an inventive step when the document is taken alone "Y" document of particular relevance; the claimed invention cannot be considered to involve an inventive step when the document is combined with one or more other such documents, such combination being obvious to a person skilled in the art "&" document member of the same patent family		
Date of the actual completion of the international search 29/02/2012		Date of mailing of the international search report 06/03/2012
Name and mailing address of the ISA/ Nordic Patent Institute, Hølgeshøj Allé 81, DK-2630 Taastrup, Denmark Facsimile No. +45 43 50 80 08		Authorized officer Peter Simonsen Telephone No. +45 43 50 83 25

INTERNATIONAL SEARCH REPORT

International application No.
PCT/DK2011/050507

Box No. II Observations where certain claims were found unsearchable (Continuation of item 2 of first sheet)

This international search report has not been established in respect of certain claims under Article 17(2)(a) for the following reasons:

1. Claims Nos.:
because they relate to subject matter not required to be searched by this Authority, namely:

2. Claims Nos.:
because they relate to parts of the international application that do not comply with the prescribed requirements to such an extent that no meaningful international search can be carried out, specifically:

3. Claims Nos.:
because they are dependent claims and are not drafted in accordance with the second and third sentences of Rule 6.4(a).

Box No. III Observations where unity of invention is lacking (Continuation of item 3 of first sheet)

This International Searching Authority found multiple inventions in this international application, as follows:
There are at least 4 unrelated inventions, see extra sheet.

1. As all required additional search fees were timely paid by the applicant, this international search report covers all searchable claims.
2. As all searchable claims could be searched without effort justifying additional fees, this Authority did not invite payment of additional fees.
3. As only some of the required additional search fees were timely paid by the applicant, this international search report covers only those claims for which fees were paid, specifically claims Nos.:
4. No required additional search fees were timely paid by the applicant. Consequently, this international search report is restricted to the invention first mentioned in the claims; it is covered by claims Nos.:

1-33, 64-65, 67

Remark on Protest

- The additional search fees were accompanied by the applicant's protest and, where applicable, the payment of a protest fee.
- The additional search fees were accompanied by the applicant's protest but the applicable protest fee was not paid within the time limit specified in the invitation.
- No protest accompanied the payment of additional search fees.

(Continuation of box III)

A: Claims 2-33, 64-65, 67. A scanner for obtaining and/or measuring a 3D geometry of at least a part of a surface of an object characterised in that the second depth of field is substantially larger than the first depth of field.

B: Claims 35-40. A scanner for obtaining and/or measuring a 3D geometry of at least a part of a surface of an object comprising a color measuring probe suitable for measuring tooth shades.

C: Claims 41-51, 70. A scanner for obtaining and/or measuring a 3D geometry of at least a part of a surface of an object comprising at least one reflective optical element arranged in the scanner.

D: Claims 52-61, 68. A scanner for obtaining and/or measuring a 3D geometry of at least a part of a surface of an object comprising means for performing spectral analysis of the light returned from the object.

Document EP 1941843 A2 (CADENT LTD.) 09.07.2008 (hereinafter denoted D1) describes a method and a scanner for obtaining and measuring a 3D geometry of at least a part of a surface of an object, the method and scanner comprising:

- a first means generating a probe light (first illumination means (section [0023]),
- means transmitting the probe light rays towards the object thereby illuminating at least a part of the object (a light focusing optics (section [0023]),
- means selecting a portion of light rays returned from the object (fig 13, mirror (620)), where the light rays have been transmitted through at least a part of the first optical system (the 2D colour image of the 3D structure that is being scanned is also obtained, but typically within a short time interval with respect to the 3D scan, section [0015], [0111], fig 13, objective lens (166)),
- a first camera comprising an array of sensor elements imaging a first depth-of-field (first detector having an array of sensor elements measuring intensity of each of a plurality of light beams returning, section [0023]),
- means varying the position of the focus plane on the object (a translation mechanism for displacing said focal plane, section [0023]),
- means obtaining at least one image from said array of sensor elements (a processor coupled to said detector),
- means determining the in-focus positions of each of a plurality of the sensor elements for a range of focus plane positions (spot-specific position, section [0010], [0011],[0023]),
- means transforming the in-focus data into 3D coordinates (data representative of the topology of said portion, section [0001], [0010], [0023]),
- a second camera (CCD) (section [0016], fig 13, (660)) capturing at least some of the selected light rays with a second depth-of-field. The second camera is used for obtaining a 2D colour image to overlay with the coordinates in the 3D entity (section [0112]).

The subject matter of claims 1, 34, 62-63, 66, 69 and 71-72 is therefore already known, and is not patentable.

Hereinafter, claims 2, 35, 41, 52, 68 and 70 do not share any special technical features which go beyond what is known from D1. Accordingly, there is no inventive concept binding the claims together and unity can not be acknowledged between inventions A, B, C and D.

INTERNATIONAL SEARCH REPORT
Information on patent family members

International application No.
PCT/DK2011/050507

Patent document cited in search report	Publication date	Patent family member(s)	Publication date
EP1941843 A2	20080709	US2010208275 A1 US2009153858 A1 US7724378 B2 US2008024768 A1 US7511829 B2 US2005283065 A1 US7698068 B2 US2006001739 A1 US7319529 B2 EP1849411 A2 EP1849411 A3 EP1607041 A2 EP1607041 A3 EP1607041 B1 EP1607064 A2 EP1607064 A3 EP1607064 B1 DE602005004332T AT383817T AT406850T	20100819 20090618 20100525 20080131 20090331 20051222 20100413 20060105 20080115 20071031 20071226 20051221 20060215 20080116 20051221 20060111 20080903 20090108 20080215 20080915
WO2010145669A1	20101223	None	
US2009079861 A1	20090326	None	



Espacenet

Bibliographic data: JP2004029373 (A) — 2004-01-29

COLOR MICROSCOPE

Inventor(s): OKAMOTO YOICHI; NAKAMU TAKASHI ± (OKAMOTO YOICHI, ; NAKAMU TAKASHI)

Applicant(s): KEYENCE CO LTD ± (KEYENCE CORP)

Classification: - **international:** G02B21/18; G02B21/36; (IPC1-7): G02B21/18; G02B21/36
- **cooperative:**

Application number: JP20020185468 20020626

Priority number (s): JP20020185468 20020626

Abstract of JP2004029373 (A)

PROBLEM TO BE SOLVED: To reduce the influence of achromatic aberration at an objective lens in a color microscope furnished with a plurality of light sources, in which a color image is obtained by condensing light having different wavelengths of the light sources on a specimen through the common objective lens. ;**SOLUTION:** A laser color microscope 100 includes a laser light optical system (a first optical system) 1 and a white light optical system (a second optical system) 2, and the optical systems have a common objective lens 17. A first focusing lens 16 of the first optical system 1 and a third focusing lens 24 of the second optical system 2 are provided with a driving mechanism D-1, D-2, respectively, and the position in the optical axis direction is adjustable, thus, the positions of first and third image forming lenses 16 and 24 are so adjusted that the focal length of the objective lens with which brightness information is derived at the first optical system 1 and the focal length of the objective lens with which color information is derived at the second optical system 2, are identical. ;**COPYRIGHT:** (C)2004,JPO

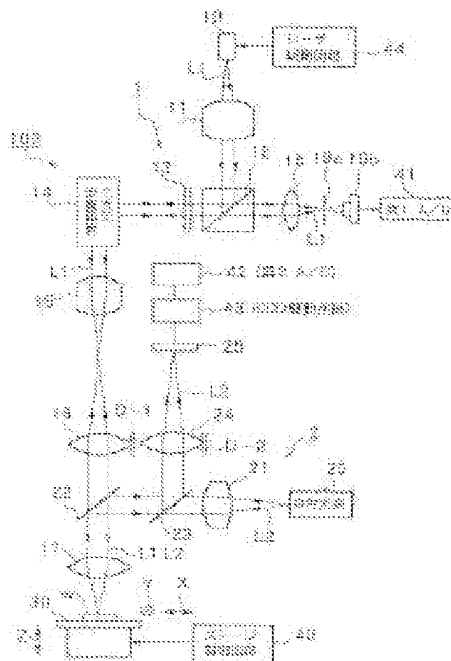

(19) 日本国特許庁(JP)

(12) 公開特許公報(A)

(11) 特許出願公開番号

特開2004-29373

(P2004-29373A)

(43) 公開日 平成16年1月29日(2004.1.29)

(51) Int. Cl.⁷

G02B 21/18

G02B 21/36

F 1

G02B 21/18

G02B 21/36

テーマコード(参考)

2H052

審査請求 未請求 請求項の数 13 O L (全 16 頁)

(21) 出願番号 特願2002-185468 (P2002-185468)

(22) 出願日 平成14年6月26日(2002.6.26)

(71) 出願人 000129253

株式会社キーエンス

大阪府大阪市東淀川区東中島1丁目3番14号

(74) 代理人 100098187

弁理士 平井 正司

(74) 代理人 100085707

弁理士 神津 堯子

(72) 発明者 岡本 陽一

大阪府大阪市東淀川区東中島1丁目3番14号
株式会社
キーエンス内

最終頁に続く

(54) 【発明の名称】 カラー顕微鏡

(57) 【要約】

【課題】 複数の光源を具備し、これらの光源の波長の異なる光を共通の対物レンズを通して試料に集光させることによりカラー画像を得るカラー顕微鏡において、対物レンズでの色収差の影響を低減する。

【解決手段】 レーザカラー顕微鏡100は、レーザ光学系(第1光学系)1と白色光光学系(第2光学系)2とを含み、これらは共通の対物レンズ17を有する。第1光学系1の第1結像レンズ16と、第2光学系2の第3結像レンズ24には、夫々、駆動機構D-1、D-2が付設されて光軸方向位置が調整可能であり、これにより、第1光学系1で輝度情報を得るときの対物レンズの焦点距離と、第2光学系2で色情報を得るときの対物レンズの焦点距離とが同じになるように第1、第3結像レンズ16、24の位置調整が行われる。

【選択図】 図1

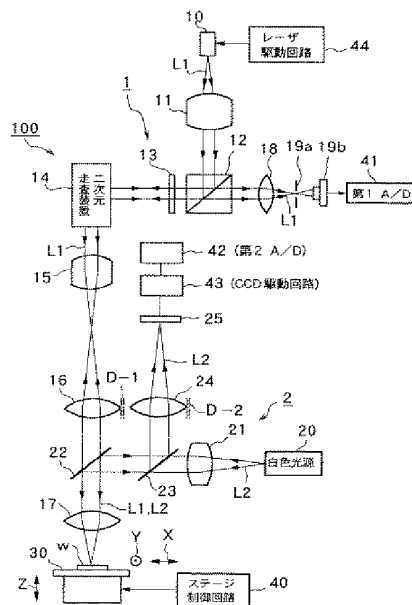

【特許請求の範囲】

【請求項1】

輝度情報を得るための第1の光源を備えた第1光学系と、色情報を得るための第2の光源を備えた第2光学系並びに、これら第1、第2の光学系が共通の対物レンズを含み、試料からの応答光に基づいて各々前記第1光学系により獲得した前記輝度情報と前記第2光学系により獲得した前記色情報とを合成することによりカラー映像用の信号を生成するカラー顕微鏡において、
前記第1光学系での前記対物レンズの焦点距離と、前記第2光学系での前記対物レンズの焦点距離とを実質的に同じにする対物レンズ焦点距離調整手段を少なくともいずれか一方の光学系が有していることを特徴とするカラー顕微鏡。

【請求項2】

輝度情報を得るための第1の光源を備えた第1光学系と、色情報を得るための第2の光源を備えた第2光学系並びに、これら第1、第2の光学系が共通の対物レンズを含み、試料からの応答光に基づいて各々前記第1光学系により獲得した前記輝度情報と前記第2光学系により獲得した前記色情報とを合成することによりカラー映像用の信号を生成するカラー顕微鏡において、
前記第1の光学系に含まれる結像レンズに付設され、該結像レンズを光軸方向に移動させるための第1の結像レンズ移動手段を有し、
該結像レンズ移動手段により、前記第1光学系での前記対物レンズの焦点距離が前記第2光学系での前記対物レンズの焦点距離と同じになるように前記第1光学系に含まれる結像レンズの光軸方向の位置を調整することができることを特徴とするカラー顕微鏡。

【請求項3】

輝度情報を得るための第1の光源を備えた第1光学系と、色情報を得るための第2の光源を備えた第2光学系並びに、これら第1、第2の光学系が共通の対物レンズを含み、試料からの応答光に基づいて各々前記第1光学系により獲得した前記輝度情報と前記第2光学系により獲得した前記色情報とを合成することによりカラー映像用の信号を生成するカラー顕微鏡において、
前記第2光学系に含まれる結像レンズに付設され、該結像レンズを光軸方向に移動させるための第2の結像レンズ移動手段を有し、
該第2の結像レンズ移動手段により、前記第2光学系での前記対物レンズの焦点距離が前記第1光学系での前記対物レンズの焦点距離と同じになるように前記第2光学系に含まれる結像レンズの光軸方向の位置を調整することができることを特徴とするカラー顕微鏡。

【請求項4】

前記第2光学系に含まれる結像レンズに付設され、該結像レンズを光軸方向に移動させるための第2の結像レンズ移動手段を更に有し、
該第1及び第2の結像レンズ移動手段により、前記第1光学系での前記対物レンズの焦点距離が前記第2光学系での前記対物レンズの焦点距離と同じになるように、前記第1及び第2光学系に含まれる結像レンズの光軸方向の位置を調整することができることを特徴とする請求項2に記載のカラー顕微鏡。

【請求項5】

輝度情報を得るための第1の光源を備えた第1光学系と、
色情報を得るための第2の光源を備えた第2光学系とを含み、
これら第1、第2の光学系が、共通の対物レンズと共通の結像レンズとを有し、
該共通の結像レンズには、該結像レンズの光軸方向の位置を調整することのできる結像レンズ移動手段が付設され、
該結像レンズ移動手段により、前記第1光学系での前記対物レンズの焦点距離が前記第2光学系での前記対物レンズの焦点距離と同じになるように、前記共通の結像レンズの光軸方向の位置を調整することができることを特徴とするカラー顕微鏡。

【請求項6】

前記第1光学系が単色光の光源を含む共焦点光学系で構成されていることを特徴とする請

求項1～5のいずれか一項に記載のカラー顕微鏡。

【請求項7】

前記第2の光源が可視光の光を出射し、前記第1の光源が、前記第2の光源とは波長の異なる単色光を出射することを特徴とする請求項1～6のいずれか一項に記載のカラー顕微鏡。

【請求項8】

前記第1の光源が、紫外線領域又は可視光線領域中で約400～420nmの短波長の光を出射する光源からなり、前記第2の光源が白色光源からなることを特徴とする請求項6に記載のカラー顕微鏡。

【請求項9】

前記共通の対物レンズが、特性の異なる複数の対物レンズから任意に選択可能であることを特徴とする請求項1～8のいずれか一項に記載のカラー顕微鏡。

【請求項10】

輝度情報を得るための第1の光源を備えた第1光学系と、色情報を得るための第2の光源を備えた第2光学系並びに、これら第1、第2の光学系が、特性の異なる複数の対物レンズから任意に選択された共通の対物レンズを含み、試料からの応答光に基づいて各々前記第1光学系により獲得した前記輝度情報と前記第2光学系により獲得した前記色情報とを合成することによりカラー映像用の信号を生成するカラー顕微鏡において、

前記第1光学系に含まれる結像レンズに付設され、該結像レンズを光軸方向に移動させるための第1の結像レンズ移動手段と、

前記第2光学系に含まれる結像レンズに付設され、該結像レンズを光軸方向に移動させるための第2の結像レンズ移動手段と、

前記選択可能な複数の対物レンズの各々の焦点距離が前記第1光学系と前記第2光学系とで同じになる前記第1、第2の光学系に含まれる結像レンズの光軸方向の位置を記憶する記憶手段と、

前記選択可能な複数の対物レンズの中から任意の対物レンズを選択したときに、この選択された対物レンズに対応する前記結像レンズの光軸方向の位置を前記記憶手段から読み出して前記第1、第2の結像レンズ移動手段により、前記第1、第2の光学系に含まれる結像レンズの光軸方向の位置を調整することを特徴とするカラー顕微鏡。

【請求項11】

前記第1光学系が単色光の光源を含む共焦点光学系で構成されていることを特徴とする請求項10に記載のカラー顕微鏡。

【請求項12】

前記第2の光源が可視光の光を出射し、前記第1の光源が、前記第2の光源とは波長の異なる単色光を出射することを特徴とする請求項10又は11に記載のカラー顕微鏡。

【請求項13】

前記第1の光源が、紫外線領域又は可視光線領域中で約400～420nmの短波長の光を出射する光源からなり、前記第2の光源が白色光源からなることを特徴とする請求項10～12のいずれか一項に記載のカラー顕微鏡。

【発明の詳細な説明】

【0001】

【発明の属する技術分野】

本発明はカラー顕微鏡に関する。本発明は、好適にはコンフォーカル走査顕微鏡に適用される。

【0002】

【従来の技術】

従来より、共焦点原理を利用したコンフォーカル顕微鏡が知られている。このコンフォーカル顕微鏡は、対物レンズとピンホールを有し、対物レンズの焦点位置に試料がある場合、該ピンホールを通過したレーザ光（応答光）を第1受光素子で受光するので、観察したい高さの部分についての画像（コンフォーカル（共焦点）画像）だけが、鮮明に映し出さ

れる（解像度が高くなる）。かかる共焦点画像は白黒（無彩色）の映像となる。

【0003】

しかし、かかる白黒の映像では情報が少なく、つまり、試料の色彩に関する情報が得られず、傷や付着物の種類の判別など詳細な観察が困難となる場合がある。そのため、特許第3205530号公報や特開平11-14907号公報に見られるようなカラー（有彩色）顕微鏡が開発されており、この種のカラー顕微鏡は、一般的には、可視領域の波長の光源が使用されている。

【0004】

【発明が解決しようとする課題】

しかしながら、例えば、例えば解像度を高めるために、輝度情報を得るための光源（典型的にはレーザー光源）として紫外線領域又は可視光線領域中で短波長領域（400～420nm程度）に属する波長の単色光を用いた場合、色情報を得るための光源（典型的には白色光源）の波長とは大きく異なることから、色収差の問題が発生する。

【0005】

この色収差には、横の色収差（倍率色収差）と、縦の色収差（軸上色収差）とが知られているが、異なる光源からの光によって対物レンズに軸上色収差が発生したときには、使用する光源によって焦点距離が大きく異なり、また、例えば短波長の単色光は被写界深度が小さいため、焦点ボケによって十分なる輝度情報が得られないという問題が発生する。

【0006】

例えば、カラーコンフォーカル顕微鏡において、非コンフォーカルモードの画面、すなわち、白色光源からの光（白色光）を試料に照射したときに得られる画面（例えば、金属顕微鏡にCCDカメラを取り付けたときの画面）と、コンフォーカルモード、すなわち、白色光源に多く含まれる波長とは大きくことなる波長を持つ光源からの光を試料に照射したときに得られる画面（例えば、紫外線レーザー顕微鏡の画面）とは、軸上色収差のために、二つの画面はどちらか一方の画面が焦点外になってしまうので、高い解像度と良好な色再現性とを両立することのできるカラー画面を得ることができない。

【0007】

そこで、本発明の目的は、複数の光源を具備し、これらの光源の波長の異なる光を共通の対物レンズを通して試料に集光させることによりカラー画像を得るカラー顕微鏡において、対物レンズでの色収差の影響を低減することのできるカラー顕微鏡を提供することにある。

【0008】

本発明の他の目的は、輝度情報を得るための光源と、色情報を得るための光源とを備えたカラー顕微鏡において、これら複数の光源から発せられる光によって対物レンズの焦点距離に差が発生するのを防止することのできるカラー顕微鏡を提供することにある。

【0009】

本発明の別の目的は、波長が大きく異なる複数の光源を用いたとしても良好なカラー画面又は像を得ることのできるカラー顕微鏡を提供することにある。

【0010】

本発明の他の目的は、輝度情報を得るために可視領域以外の領域の波長の光を発する光源を用いた場合に発生し易い色収差の問題を解消することのできるカラー顕微鏡を提供することにある。

【0011】

輝度情報を得るための光の波長と色情報を得るための光の波長とが大きく異なっていたとしても、良好な解像度と良好な色再現性とを両立することのできるコンフォーカルカラー走査顕微鏡を提供することにある。

【0012】

【課題を解決するための手段】

かかる技術的課題は、本発明の第1の観点によれば、

輝度情報を得るための第1の光源を備えた第1光学系と、色情報を得るための第2の光源

を備えた第2光学系並びに、これら第1、第2の光学系が共通の対物レンズを含み、試料からの応答光に基づいて各々前記第1光学系により獲得した前記輝度情報と前記第2光学系により獲得した前記色情報とを合成することによりカラー映像用の信号を生成するカラー顕微鏡において、

前記第1光学系での前記対物レンズの焦点距離と、前記第2光学系での前記対物レンズの焦点距離とを実質的に同じにする対物レンズ焦点距離調整手段を少なくともいずれか一方の光学系が有していることを特徴とするカラー顕微鏡を提供することにより達成される。

【0013】

上述した技術的課題は、本発明の第2の観点によれば、

輝度情報を得るための第1の光源を備えた第1光学系と、色情報を得るための第2の光源を備えた第2光学系並びに、これら第1、第2の光学系が共通の対物レンズを含み、試料からの応答光に基づいて各々前記第1光学系により獲得した前記輝度情報と前記第2光学系により獲得した前記色情報とを合成することによりカラー映像用の信号を生成するカラー顕微鏡において、

前記第1の光学系に含まれる結像レンズに付設され、該結像レンズを光軸方向に移動させるための第1の結像レンズ移動手段を有し、

該結像レンズ移動手段により、前記第1光学系での前記対物レンズの焦点距離が前記第2光学系での前記対物レンズの焦点距離と同じになるように前記第1光学系に含まれる結像レンズの光軸方向の位置を調整することができることを特徴とするカラー顕微鏡を提供することにより達成される。

【0014】

上述した技術的課題は、本発明の第2の観点によれば、

輝度情報を得るための第1の光源を備えた第1光学系と、色情報を得るための第2の光源を備えた第2光学系並びに、これら第1、第2の光学系が共通の対物レンズを含み、試料からの応答光に基づいて各々前記第1光学系により獲得した前記輝度情報と前記第2光学系により獲得した前記色情報とを合成することによりカラー映像用の信号を生成するカラー顕微鏡において、

前記第2光学系に含まれる結像レンズに付設され、該結像レンズを光軸方向に移動させるための第2の結像レンズ移動手段を有し、

該第2の結像レンズ移動手段により、前記第2光学系での前記対物レンズの焦点距離が前記第1光学系での前記対物レンズの焦点距離と同じになるように前記第2光学系に含まれる結像レンズの光軸方向の位置を調整することができることを特徴とするカラー顕微鏡を提供することにより達成される。

【0015】

本発明は、第1光学系と第2光学系とで用いられる共通の対物レンズの色収差補正が十分になされていない波長領域の光を発する光源を使用するときに効果的である。本発明は、最も典型的には、前記第1光学系により前記輝度情報を得る又は前記第2光学系により前記色情報を得るときに、これに先だって、結像レンズの位置を調整することにより共通の対物レンズの焦点距離が第1光学系及び第2光学系とで同じになるように設定することができることから、第1又は第2の光学系で輝度情報又は色情報を得るときに、対物レンズの軸上色収差の影響を受けることなく輝度情報又は色情報を獲得することができる。したがって、第1光学系で使用する光源と第2光学系で使用する光源との間で大きく波長の異なっていたとしても良好なカラー画面を得ることができる。

【0016】

本発明は、前記第1光学系が単色光の光源を含む共焦点光学系で構成されたコンフォーカルカラー顕微鏡に好適に適用される。このコンフォーカルカラー顕微鏡において、輝度情報を得るための第1光学系の光源として、紫外線領域又は赤外線領域の波長の光源を用いることができ、特に、解像度の高い画像を得るために紫外線領域又は可視光線領域中の短波長領域(400~420nm程度)に属する短波長の単色光を発する光源を採用しても、軸上色収差に影響を受けることなく良好なカラー画面を得ることができる。

【0017】

【発明の実施の形態】

以下、本発明の実施形態を図面にしたがって説明する。

【0018】

第1の実施形態（図1～図5）

図1において、コンフォーカル走査顕微鏡（レーザ顕微鏡）100は、レーザ光光学系（第1光学系）1と、白色光光学系（第2光学系）2とを備えている。

【0019】

レーザ光光学系1

レーザ光光学系1は、試料wの深度に関する情報を検出できる共焦点光学系で、可視領域の波長のレーザ光であってもよいが、赤外線領域又は紫外線領域のレーザ光、好ましくは紫外線領域又は可視光線領域中で短波長領域（400～420nm程度）に属する短波長のレーザ光L1を射出するレーザ光源10を有する。なお、レーザ光源10に代えて、赤外線領域又は紫外線領域の波長の単色光を放射する光源、例えば高輝度ランプであってもよく、また、レーザ光光学系1は単一であってもよいが、複数であってもよい。複数のレーザ光光学系1を具備している場合、各レーザ光光学系1は、異なる波長の単色光源を備えることとなる。

【0020】

レーザ光源10の光軸上には、レーザ光源10側から、順に、第1のコリメートレンズ11、偏光ビームスプリッタ12、1/4波長板13、二次元走査装置14、第1リレーレンズ15、第1の結像レンズ16、対物レンズ17が配設されており、この対物レンズ17は特性の異なるレンズが複数用意され、操作者は任意の対物レンズを選択して使用することが可能である。また、第1の結像レンズ16には第1駆動機構D-1が付設され、この第1駆動機構D-1によって、第1結像レンズ16の配置位置を光軸に沿って（図面で上下方向に）調整することができる。

【0021】

対物レンズ17の焦点位置の付近には、試料ステージ30が配設されており、試料ステージ30は、ステージ制御回路40によりZ方向（上下方向）に駆動制御され、X、Y方向については手動ハンドルで移動可能となっており、この試料ステージ30の上下方向位置を調整することにより、対物レンズ17はレーザ光L1を試料wの表面に集光させる。前述の二次元走査装置14は、例えば2枚のガルバノミラーから構成され、レーザ光L1を偏向させることで、試料wへの集光位置を試料wの表面に沿って二次元的（X方向及び/又はY方向）に走査させる。

【0022】

試料wで反射されたレーザ光（応答光）L1は、レーザ入射光と同じ経路をたどって、対物レンズ17、第1の結像レンズ16、第1リレーレンズ15を通り、再び、二次元走査装置14を介して1/4波長板13および偏光ビームスプリッタ12を透過し、第2の結像レンズ18に向かう。応答光つまり反射光であるレーザ光L1は、第2の結像レンズ18を通り、この第2の結像レンズ18で集光されてピンホールを有する光絞り部19aを通り、光絞り部19aを通過したレーザ光L1は第1受光素子19bに入射する。第1受光素子19bは、たとえばフォトマルチプライヤまたはフォトダイオードなどで構成され、入射したレーザ光L1を光電変換して、アナログ光量信号を、出力アンプおよびゲイン制御回路（図せず）を介して第1A/Dコンバータ41に出力する。

【0023】

つぎに、レーザ光光学系1によって得られる輝度情報について説明する。

【0024】

前述の光絞り部19aは、第2の結像レンズ18の焦点位置に配設されており、一方、光絞り部19aのピンホールは極めて微小であるから、レーザ光L1が試料w上で焦点を結ぶと、その反射光L1が、第2の結像レンズ18によって光絞り部19aのピンホールで結像し、第1受光素子19bに入射する受光光量が著しく大きくなり、逆に、レーザ光L

1が試料w上で焦点を結んでいないと、その反射光L1は、光絞部19aのピンホールを殆ど通過しないので、第1受光素子19bの受光量が著しく小さくなる。したがって、レーザ光光学系1による撮像領域(走査領域)のうち、焦点の合った部分(合焦点の撮像単位)について明るい映像が得られ、一方、それ以外の高さの部分については暗い映像が得られる。なお、レーザ光光学系1は、単色光としてレーザ光L1を用いた共焦点光学系であり、特に、短波長である紫外線領域のレーザ光を用いたときには、分解能に優れた輝度情報を得ることができる。

【0025】

白色光光学系2

白色光光学系2は、白色光(色情報用の照明光)L2を射出する白色光源20を光源としている。白色光源20の光軸上には、第2のコリメートレンズ21、第1のハーフミラー22、第2のハーフミラー23及び前記対物レンズ17が配設されており、前記第1のハーフミラー22において2つの光学系1、2の光軸が合致するように白色光光学系2が配設されている。したがって、白色光L2は、共通の対物レンズ17を通過してレーザ光L1の走査領域と同一の箇所に集光される。

【0026】

また、試料wで反射された白色光(応答光)L2は、白色入射光と同じ経路をたどって、先ず、共通の対物レンズ17を通過し、次いで第1のハーフミラー22で反射され、更に、第2のハーフミラー23で反射され、そして、第3の結像レンズ24を通過し、この第3の結像レンズ24によってカラーCCD(第2受光素子)25の表面で結像する。すなわち、カラーCCD25は、光絞部19aと共役ないし共役に近い位置に配設されている。なお、カラーCCD25で撮像された画像は、アナログのカラー撮像情報として、CCD駆動回路43に読み出されて第2A/Dコンバータ42に出力される。

【0027】

この白色光光学系2の第3の結像レンズ24には第2の駆動機構D-2が付設され、この第2の駆動機構D-2によって第3の結像レンズ24の配置位置を光軸に沿って(図面で上下方向に)調整することができる。

【0028】

ここに、カラー撮像情報とは、光の三原色(赤、緑、青)についての強度からなる映像情報や、輝度情報および色差情報や、水平同期信号およびカラーバースト信号を含んだ複合カラー映像情報など、そのまま、または、加工した後、カラーの映像を映し出すことのできる情報をいう。

【0029】

つぎに、後述するカラー共焦点画像(カラスライス画像)モードにおいて作動する図2のカラー映像信号作成手段5について説明する。

【0030】

カラー映像信号作成手段5は、第1受光素子19bからの輝度情報と、カラーCCD25からの色情報とを組み合わせて、カラー映像用のデジタル信号r_o、g_o、b_oを作成するものである。前記カラー映像信号作成手段5は、第1および第2領域回路51、52と、輝度変換回路53などを備えている。ここに、輝度情報とは、色彩を含まない輝度に関する情報をいい、「色情報」とは、たとえば色差信号のように、色の強度のバランスに関する情報をいう。

【0031】

前記第1および第2領域回路51、52は、図3に示すように、それぞれ、レーザ光光学系1および白色光光学系2の撮像領域A1、A2の所定の共通部分を映像領域A0として選択し、選択した部分についてデジタル信号を出力する。すなわち、図2の第1領域回路51は、前記映像領域A0について、カラーCCD25の各画素に対応した分解能で輝度信号iを輝度用メモリMiに記憶させる。一方、前記第2領域回路52は、前記映像領域A0について、各画素ごとに赤、緑、青の色強度信号r_m、g_m、b_mを第1色強度メモリMr1、Mg1、Mb1に記憶させる。なお、色強度信号とは、三原色についての輝度

(強度)を含む信号をいう。

【0032】

前記輝度変換回路53は、下記の演算式(1)、(2)、(3)にしたがって、各画素についての前記色強度信号 r_m 、 g_m 、 b_m の輝度情報を、輝度信号 i の輝度情報に置換して、変換色強度信号 r_o 、 g_o 、 b_o を求め、該信号を第2色強度メモリ Mr_2 、 Mg_2 、 Mb_2 に記憶させるものである。

【0033】

$$R_o = I \cdot R_m / (R_m + G_m + B_m) \quad \dots (1)$$

$$G_o = I \cdot G_m / (R_m + G_m + B_m) \quad \dots (2)$$

$$B_o = I \cdot B_m / (R_m + G_m + B_m) \quad \dots (3)$$

【0034】

ここに、 I は輝度信号 i の輝度であり；

R_m 、 g_m 、 b_m は色強度信号 r_m 、 g_m 、 b_m の輝度(強度)であり；

R_o 、 G_o 、 B_o は変換色強度信号 r_o 、 g_o 、 b_o の輝度(強度)である。

【0035】

なお、第1および第2色強度メモリ $Mr_1 \sim Mb_1$ 、 $Mr_2 \sim Mb_2$ は、カラーCCD25のうち前述の映像領域 A_o の部分の画素に対応した記憶部を有している。

【0036】

このようにして得られた変換色強度信号 r_o 、 g_o 、 b_o は、カラーCCD25からのカラー撮像情報のうちの輝度情報を、第1受光素子19bからの輝度情報に置換した信号となる。前記変換色強度信号 r_o 、 g_o 、 b_o は、前記第2色強度メモリ Mr_2 、 Mg_2 、 Mb_2 から読み出されて、D/Aコンバータ60に出力され、更に、加算器61において同期信号 a が付加されて、アナログの複合カラー映像信号 c となる。該複合カラー映像信号 c はモニタ62に出力されて、試料 w の映像が映し出される。

【0037】

走査顕微鏡100の使用法

走査顕微鏡100は、領域探索モード、白黒(無彩色)共焦点画像モードおよびカラー共焦点画像(カラースライス画像)モードの3つのモードのうち1つを選択して用いる。これらのモードの設定は、操作部63を操作して設定する。

【0038】

モードの設定に先立ち、走査顕微鏡100の初期操作として、図4のステップS10に示すように、走査顕微鏡100で選択可能な複数の特性の異なる対物レンズの各々について、レーザ光光学系1により輝度情報を得るときの対物レンズの焦点距離と、白色光光学系2による色情報を得るときの対物レンズの焦点距離とが同じになるように、レーザ光光学系1の第1結像レンズ16の位置と白色光光学系2の第3結像レンズ24の位置を、第1、第2の駆動手段D-1、D-2により調整して、その位置を予め測定し、その結果をメモリに記憶させる。

【0039】

次いで、選択可能な複数の対物レンズの中から操作者が一つの対物レンズを選択したときには(ステップS11)、この選択された対物レンズ17に対応する記憶値つまりステップS10で測定した位置となるように、第1、第2の駆動手段D-1、D-2により第1、第3の結像レンズ16、24を光軸に沿って移動させる(ステップS12)。これにより、走査顕微鏡100は、セットされた対物レンズ17に関し、レーザ光光学系1による輝度情報を得るときの対物レンズ17の焦点距離と、白色光光学系2による色情報を得るときの対物レンズ17の焦点距離とは同じになる。

【0040】

したがって、操作者が任意の対物レンズ17を選択して、レーザ光光学系1及び白色光光学系2を用いて輝度情報及び色情報を得るときに対物レンズ17の色収差の影響を防止することができ、特に、レーザ光光学系1で紫外線又は可視光線領域中で短波長領域(400~420nm程度)に属する波長の単色光を用いたときに効果的である。

【0041】

操作者が、上述した操作部63を操作することにより領域探索モードが選択されると、カラー映像信号作成手段5は図1のレーザ駆動回路44を停止させると共に、CCD駆動回路43を作動させてカラーCCD25により撮像させる。この領域探索モードでは、図2の第2領域回路52から第1色強度メモリMr1、Mg1、Mb1に記憶された色強度信号rm、gm、bmが、そのまま、D/Aコンバータ60に出力されて、被写界深度の深い通常の拡大画像がモニタ62に映し出される。したがって、図1の試料ステージ30をX方向及び/又はY方向に移動させることにより、撮像したい領域を探し出すことができる。

【0042】

白黒共焦点画像モードが選択されると、カラー映像信号作成手段5(図2)は、レーザ光光学系1のレーザ駆動回路44および二次元走査装置14などを作動させ、レーザ光光学系1により撮像させる。この白黒共焦点画像モードでは、図2の第1領域回路51から輝度用メモリMiに記憶された輝度信号iが、そのまま、D/Aコンバータ60に出力されて、解像度の高い白黒(無彩色)の拡大画像がモニタ62に映し出される。

【0043】

カラー共焦点画像(カラースライス画像)モードが選択されると、以下に説明するように、レーザ駆動回路44とCCD駆動回路43とが交互に駆動される。

【0044】

カラースライス画像モード(図5)

すなわち、図5のステップS20で、この第1カラースライス画像モードが選択されると、ステップS21に進み、レーザ光L1による1画面分の走査がなされた後、ステップS22に進む。ステップS22では図1のレーザ駆動回路44が停止し、レーザ10からレーザ光L1が出射されなくなる。この状態で図5のステップS23に進み、カラーCCD25に電荷を蓄積する。このステップS23で得た図2の色強度信号rm、gm、bmは、該信号に含まれている輝度情報が前記ステップS21で得た輝度信号iの輝度情報に置換され、変換色強度信号ro、go、boとなる。該変換色強度信号ro、go、boは、それぞれ、第2色強度メモリMr2、Mg2、Mb2に記憶された後、D/Aコンバータ60に出力されてカラーの拡大画像がモニタ62に映し出される。

【0045】

なお、図5のステップS23の後にステップS24に進み、このモードがOFFされるまで、前記レーザ光L1の走査と、CCD駆動回路43による電荷の蓄積および読み出しが繰り返される。このようにして得られるカラー共焦点画像が得られる。

【0046】

本実施形態の場合、図1のカラーCCD25によって撮像する(カラーCCD25に電荷を蓄積する)際には、レーザ駆動回路44を停止してレーザ光L1がカラーCCD25に入射しないようにしている。したがって、レーザ光L1の色を帯びた映像になることもなく、試料wの実際の色に近い色彩の映像が得られる。

【0047】

なお、レーザ光L1がカラーCCD25に入射しないようにする手段としては、レーザ光L1を遮光するシャッターを用いたり、あるいは、レーザ光L1の走査範囲をカラーCCD25の撮像領域外に設定するなど種々の方法を採用することができる。また、レーザ光L1がカラーCCD25に入射して、レーザ光L1の色を帯びても、カラーの映像が得られるので、本発明の範囲に含まれる。

【0048】

以上、第1の実施形態として、対物レンズ17として複数のレンズを用意して操作者が任意の対物レンズ17を選択する形式の顕微鏡100を説明したが、可視領域の波長に適合した対物レンズ17が固定的にセットされた顕微鏡であれば、白色光光学系2の第3結像レンズ24に付設した第2駆動機構D-2を省いてもよい。このような顕微鏡であれば、レーザ光光学系1の第1結像レンズ16に付設した第1駆動機構D-1によって、レーザ

光光学系1により輝度情報を得るときの対物レンズの焦点距離と、白色光光学系2による色情報を得るときの対物レンズの焦点距離とが同じになるように第1結像レンズ16の位置を調整するようにしてもよい。

【0049】

第2の実施形態(図6)

前記第1の実施形態では、試料wの表面および第1受光素子19bにおいて点状に集光するレーザ光L1を用いたが、試料wの表面および第1受光素子19bにおいて線状に集光するラインレーザ光L1を用いてもよい。すなわち、図6に示す第2の実施形態のレーザ顕微鏡200のように、レーザ光L1に代えてY方向に長いラインレーザ光L1を用いると共に、点状の第1受光素子19bに代えてY方向に長い二次元CCD19Aを用い、更に、二次元走査装置14に代えて二次元走査装置14Aを用いる。この場合、図6(b)のように、ラインレーザ光L1が試料wの表面で集光した際の長手方向に直交する方向に、ラインレーザ光L1を走査する。なお、光絞部19aはスリット状(溝状)にする。

【0050】

また、第1の実施形態では、試料wで反射された白色光(応答光)L2が、対物レンズ17と第1結像レンズ16との間に配置した第1のハーフミラー22で反射されるようになっていたが、この第2の実施形態の顕微鏡200では、第1結像レンズ16を兼用することにより第3の結像レンズ24(図1)を省略している。それに伴い、第2のハーフミラー23が第2のリレーレンズ16と第1のリレーレンズ15との間に設けられる。

【0051】

したがって、試料wで反射された白色光(応答光)L2は、対物レンズ17、第1結像レンズ16を通り、次いで、第2のハーフミラー23で反射され、カラーCCD(第2受光素子)25の表面で結像するようになっている。なお、この第2実施形態の顕微鏡200にあっても、対物レンズ17として複数種類の凸レンズが用意され、操作者の選択により一つの対物レンズ17がセットされるようになっている。

【0052】

この第2の実施形態のレーザ顕微鏡200では、先に説明した顕微鏡100(図1)と同様の動作モード、つまり領域探索モード、白黒(無彩色)共焦点画像モードおよびカラー共焦点画像(カラースライス画像)モードの3つのモードのうち1つを選択して用いるのがよい。これらのモードの設定は、操作部63を操作して設定することが可能である。

【0053】

カラースライス画像モードを選択したときには、図7に示すステップで動作するのが好ましい。

【0054】

すなわち、図7のステップS40でカラースライス画像モードが選択されると、ステップS41に進み、白色光光学系2で色情報を得るときと、レーザ光光学系1で輝度情報を得るときの対物レンズ17の焦点距離が同じになるように白色光光学系2を動作させたときの第1結像レンズ16の位置 α と、レーザ光光学系1を動作させたときの第1結像レンズ16の位置 β とを各対物レンズ17毎に測定し、各対物レンズ17毎に位置 α と β とをメモリに記憶させる。この位置 α 及び β を測定するときには第1結像レンズ16に付設されている第1駆動手段D-1を動作させることにより第1結像レンズ16を上下に移動させることにより行われる。

【0055】

次いで、ステップS42に進み、操作者により選択された対物レンズ17に対応する位置 β となるように第1結像レンズ16を移動させた後に、ステップS43に進んで、レーザ光L1による1画面分の走査がなされた後、ステップS44に進む。このステップS44では図6のレーザ駆動回路44が停止し、レーザ10からレーザ光L1が射出されなくなる。

【0056】

次いでステップS45に進み、選択されている対物レンズ17に対応する位置 α となるように第1結像レンズ16を移動させた後に、ステップS46に進んで、白色光源20を点灯させてこれを試料wに照射し、この試料wで反射した白色光はカラーCCD25に電荷を蓄積する。

【0057】

このステップS46で得た図2の色強度信号 r_m 、 g_m 、 b_m は、該信号に含まれている輝度情報が前記ステップS43のレーザ光走査で得た輝度信号 i の輝度情報に置換され、変換色強度信号 r_o 、 g_o 、 b_o となる。該変換色強度信号 r_o 、 g_o 、 b_o は、それぞれ、第2色強度メモリMr2、Mg2、Mb2に記憶された後、D/Aコンバータ60に出力されてカラーの拡大画像がモニタ62に映し出される(ステップS47)。

【0058】

次いで、ステップS48で、再び、選択されている対物レンズ17に対応する位置 β となるように第1結像レンズ16を移動させた後に、次のレーザ光走査(ステップS43)に備える。すなわち、このカラースライス画像モードがオフされるまで、ステップS49から上記ステップS43に戻り、ステップS43~48の動作を反復して、前記レーザ光L1の走査と、CCD駆動回路43による電荷の蓄積および読み出しが繰り返される。

【0059】

前記第2の実施形態では、図6のレーザ光学系1の第1受光素子19Aの前方に光絞り部19aを設けたが、該光絞り部19aは必ずしも設ける必要はない。

【0060】

第3の実施形態(図8)

図8に示す第3の実施形態のレーザ顕微鏡300のように、第2の結像レンズ18の焦点の位置に白黒用の二次元CCD19Aを設け、第1の二次元走査装置14Aを第1のコリメートレンズ11と偏光ビームスプリッタ12の間に設け、第2の二次元走査装置14Bと1/4波長板13と第1リレーレンズ15との間に設けてもよい。

【0061】

この第3の実施形態のレーザ顕微鏡300では、第2のハーフミラー23を図1の位置に配置してもよく、或いは、図6に図示のように、第1の結像レンズ16と第1リレーレンズ15との間に配置してもよい。

【0062】

この第3の実施形態の顕微鏡300でカラースライス画像モードを選択したときには、図7で説明した手順で動作する。

【0063】

第4の実施形態(図9)

図9に示す第4の実施の形態のレーザ顕微鏡400は、図1の第1の実施の形態のレーザ顕微鏡100と図8の第3の実施の形態のレーザ顕微鏡300とを組み合わせたものである。すなわち、レーザ光源10から第1リレーレンズ15までの光路構成と第1リレーレンズ15から第1受光素子19bまでの光路構成は第1実施の形態のレーザ顕微鏡100と同一であり、また、第1リレーレンズ15と対物レンズ17間の光路構成は第3の実施の形態のレーザ顕微鏡300と同一である。

【0064】

以上、本発明の好ましい実施の形態を説明したが、例えば、図1、図6、図7及び図8及び図9の第2光学系2において、第2受光素子として、カラーCCDの他に、前方に回転RGBフィルタを用いた二次白黒面受光素子(例えばCCD)であってもよいし、ダイクロックミラー群と各々がRGB用の3つの二次白黒面受光素子であってもよく、また、MOS型などの他の固体撮像素子や複数の撮像管を組み合わせたテレビカメラなどを用いることもできる。

【0065】

なお、レーザ光L1を走査する走査装置を白色応答光に対して兼用する場合は、次のような例が考えられる。図9の場合は、二次元走査装置14がX方向走査部とY方向走査部と

より構成（Y方向走査部が第1リレーレンズ15側、言い換えれば、白色応答光を最初にY方向に走査する）されている場合、Y方向走査部とX方向走査部との間に第2のハーフミラー23を配置してもよい。この場合、第2受光素子としては一次元カラー受光素子や、前方に回転RGBフィルタを設けた一次元白黒受光素子や、ダイクロックミラー群と3つの一次元白黒受光素子を用いる。

【0066】

また、図6と図8の場合は、1/4波長板13と一次元走査装置14A（図8においては14B）の間に第2のハーフミラー23を配置してもよい。この場合、第2受光素子としてはダイクロックミラー群と3つの一次元白黒受光素子を用いる。なお、第2受光素子として一次元カラー受光素子や、前方に回転RGBフィルタを設けた一次元白黒受光素子も用いることができるが、この場合は、第2受光素子を第1受光素子としても使用できる。但し、回転RGBフィルタは、RGB以外に白色応答光を直接一次元白黒受光素子に導く部分（開口部など）が必要となる。

【0067】

同様に、図9においても、二次元走査装置14と1/4波長板13との間に第2ハーフミラー23を配置してもよい。この場合、第2受光素子としては、前方に回転RGBフィルタを設けた二次元受光素子や、ダイクロックミラー群と3つの二次元受光素子を用いる。

【0068】

なお、前述した各々の第2のハーフミラー23の配置の変形例において、第2のハーフミラー23の配置が変更されたことに伴い、第2受光素子25、CCD駆動回路43及び第2A/D42の配置も変更されることは言うまでもない。

【0069】

上述した実施形態では、色彩を光の三原色に分解したが、補色系（黄、シアン、緑）に分解してもよい。また、色情報として色差信号を用いてもよい。

【0070】

また、コンフォーカルカラー顕微鏡は、図1に例示したように共焦点（コンフォーカル）光学系1が単一であってもよいが、この共焦点光学系1を複数備えていてもよい。複数のコンフォーカル光学系を備えた顕微鏡にあっては、全ての光源に関連して個々に独立した結像レンズを備えていてもよいが、複数のコンフォーカル光学系が共用する結像レンズを備えていてもよい。

【図面の簡単な説明】

【図1】第1実施形態のカラー走査顕微鏡の概略構成図である。

【図2】ブロック図である。

【図3】撮像領域を示す平面図である。

【図4】第1実施形態のカラー走査顕微鏡での初期操作を説明するためのフローチャートである。

【図5】カラスライス画像モードでの操作手順を説明するためのフローチャートである。

【図6】第2実施形態の走査顕微鏡の概略構成図である。

【図7】第2実施形態でのカラスライス画像モードでの操作手順を説明するためのフローチャートである。

【図8】第3実施形態の走査顕微鏡の概略構成図である。

【図9】第4実施形態の走査顕微鏡の概略構成図である。

【符号の説明】

- 1：第1光学系（レーザ光光学系）
- 16：第1結像レンズ（共通の結像レンズ）
- 17：共通対物レンズ
- 18：第2結像レンズ
- 19b：第1受光素子
- 2：第2光学系（白色光光学系）