

颜色之间选择性切换,由此用不同的颜色照明物体。如果使用白色光源,则必须提供某种色彩过滤。优选包括多个滤色片,例如红色、绿色和蓝色滤色片,以及将所述滤色片单独插入白色光源前方的装置,由此选择探测光的颜色。

[0189] 在本发明的一个实施例中,将滤色片整合到图案产生装置中,即,图案产生装置包括滤色片,例如基本上以单色着色的半透明和/或透明部件。例如,图案元件例如为具有不透明遮盖件的旋转轮,且其中半透明/透明部件是滤色片。例如轮的三分之一是红色,三分之一是绿色且三分之一是蓝色。

[0190] 也可以通过至少三个单色光源,例如激光或发光二极管的光源,提供不同颜色的探测光,所述光源具有分布在波长光谱的可见光部分的波长。这一般还会要求用于归并所述光源的装置。例如适当涂层的板。在波导光源的情况下,可以通过波导元件提供归并。

[0191] 为了处理探测光的不同颜色,光学系统优选地是基本上消色差的。

[0192] 本发明的一个实施例包括对于一焦平面位置在探测光的至少两种颜色,优选三种颜色,例如红色、绿色和蓝色之间切换的装置。即,对于单个焦平面位置,可在探测光的不同颜色之间切换。例如通过打开和关闭不同的单色光源(每次仅有一个光源打开)或者通过使用不同的滤色片。此外,可以对每个焦平面位置每种颜色确定多个感测器元件中的每一个的光信号幅度。即,对于每个焦点位置都可以切换探测光的颜色。嵌入的时变图案提供单色振荡光信号,且可以对于该颜色确定每个感测器元件中的信号幅度。切换到下一个颜色可再次确定幅度。当对所有颜色确定了幅度时,改变焦点位置并重复该过程。然后,被扫描表面的颜色可以通过合并和/或加权来自于多个感测器元件的颜色信息而获得。例如,表达为例如每个表面元素的 RGB 颜色坐标的颜色可以通过适当地加权对应于最大幅度的每个颜色的幅度信号而重建。也可以在提供静止图案时应用该技术,其中至少一部分图案的颜色是随时间变化的。

[0193] 为了降低所处理的数据量,可以选择成像的颜色分辨率低于空间分辨率。然后通过数据插值提供颜色信息。因此,在本发明的一个实施例中,对于选定的全色焦平面位置的每种颜色确定多个感测器元件中的每一个的光信号幅度,并且对于每个焦平面位置的一种颜色确定多个感测器元件中的每一个的光信号幅度。然后通过来自全色焦平面位置的颜色信息进行插值来获得被扫描表面的颜色。因此,例如以 N 个焦点位置的间隔对所有颜色登记幅度;同时选择一种颜色以确定所有焦点位置的幅度。 N 是可以为例如 3、5 或 10 的数。这导致小于表面拓扑结构的分辨率的颜色分辨率。也可以在提供静止图案时应用该技术,其中至少一部分图案的颜色是随时间变化的。

[0194] 本发明的另一个实施例没有登记全部颜色信息并且采用仅仅两个具有不同颜色的光源。这种情况的实例是牙齿扫描器,其用红色和蓝色光区分硬(牙齿)组织和软(牙龈)组织。

[0195] 印模扫描

[0196] 本发明的一个实施例适于印模扫描,例如牙齿印模和/或耳道印模的扫描。

[0197] 小腔扫描

[0198] 根据本发明的扫描器的具体应用与腔,特别是体腔的扫描有关。腔内的扫描可与腔内物体的扫描有关,例如口中牙齿的扫描。然而,例如耳朵的扫描与腔本身内表面的扫描有关。一般来说,腔特别是小腔的扫描要求某种用于扫描器的探头。因此,在本发明的一个

实施例中,探测光的发射点和反射光的收集点位于探头上,所述探头适于进入腔内,例如体腔。

[0199] 在本发明的另一个实施例中,探头适于扫描腔表面例如耳道的至少一部分。扫描耳朵外部的至少一部分和/或耳道并且形成耳朵的虚拟或真实模型的能力在现代的顾客特制的助听器(例如耳套或耳模)的设计中是很重要的。如今,以两步程序进行耳朵的扫描,其中首先获得耳朵的硅树脂印模,和随后在第二步中使用外部扫描器对印模进行扫描。

[0200] 因此,本发明的一个实施例包括:

[0201] 容纳照相机、图案产生装置、焦点变化装置和数据处理装置的外壳,和

[0202] 容纳第一光学系统的至少一个探头,优选地基本上细长的探头。

[0203] 优选地,探测光的发射点和从扫描物体返回的光的收集点位于所述探头上。探头中的光学系统用于将来自外壳的探测光向物体传输,也用于将从物体返回的光向后向放置照相机的外壳传输和/或成像。因此,探头中的光学系统可包括透镜系统。在本发明的一个实施例中,探头可包括至少一个光学纤维和/或纤维束,用于传输/传送/引导探测光和/或从物体表面返回的光。在这种情况下,(多个)光学纤维可起到仅在探头内部传送光(即探测光和返回光)的光学中继系统的作用。在本发明的一个实施例中,探头是内窥镜装置。探头可以是刚性的或柔性的。在探头中使用(多个)光学纤维可例如提供具有小直径的柔性探头。

[0204] 在本发明的一个实施例中,仅仅借助探头中的光学系统,第一光学系统将光传输给物体并成像。然而,在本发明的又一个实施例中,外壳可进一步包括第二光学系统。

[0205] 在本发明的又一个实施例中,探头是可以从外壳上分离的。因而优选地,探测光的第一发射点和返回光的第一收集点位于探头上,并且探测光的第二发射点和返回光的第二收集点位于外壳上。这可能在外壳和探头两者中都需要光学系统。因此,可以用装配到外壳上的探头获得扫描。然而,也可以用与外壳分离的探头获得扫描,即外壳本身可以是独立的扫描器。例如,探头可以适合于插入并扫描腔的内部,而外壳可以适合于外表面的扫描。探头的装配可包括外壳和探头之间的机械和/或电子传递。例如,装配探头可将电信号提供给外壳中的控制电子设备,其用信号表示设备的电流构形。

[0206] 在本发明的一个实施例中,以基本上平行于光轴和/或探头纵轴的方向将探测光导向物体。在又一个实施例中,探头包括后部的反射元件,例如镜子,用于将探测光导入不同于光轴的方向,优选地垂直于光轴的方向。用于具有分离探头的独立扫描器外壳的上述实例,探测光可沿平行于外壳中的光学系统(即第二光学系统)的光轴的方向离开外壳,然而在装配有探头的情况下,探测光可被导入不同于探头的光学系统(即第一光学系统)的光轴的方向。由此探头更好地适于扫描腔。

[0207] 在本发明的某些实施例中,扫描器中产生的废热用于加热探头从而当探头在体腔如口腔内部时没有或有较少的凝聚发生在探头上。废热例如可以由处理电子设备、光源和/或移动聚焦元件的机械装置产生。

[0208] 在本发明的某些实施例中,当将随后的扫描登记到更大的3D表面模型失败时,扫描器向使用者提供反馈。例如,扫描器可使光源闪光。

[0209] 此外,探头可包括用于使反射元件优选地围绕基本上平行于光轴和/或探头纵轴的轴旋转/自旋的装置。由此,探头可以适合于提供围绕光轴和/或探头纵轴的360°扫

播,优选地探头和/或扫描器不旋转。

[0210] 在本发明的又一个实施例中,多个不同的探头匹配外壳。由此,适于不同环境、表面,腔等等的不同探头可装配到外壳上以解决不同的扫描情况。这方面的具体实例是当扫描器包括适于扫描人耳内部的第一探头和适于扫描所述人耳外部的第二探头时。取代第二探头的可以是外壳本身,即,具有分离探头的外壳,其适于扫描所述人耳的外部。即,外壳可以适合于进行 3D 表面扫描。换句话说,具有装配好的探头的外壳可适合于扫描人耳的内部,而具有分离探头的外壳可适合于扫描所述人耳的外部。优选地,提供用于归并和/或合并耳内部和外部 3D 数据的装置,由此提供人耳的完整 3D 模型。

[0211] 对于本发明的手持实施例,手枪状的设计是人体工程学设计,因为该装置舒适地躺在操作者手内,其中大部分质量躺在手和/或手腕上。在这种设计中,有利的是能够在多个位置对上述后部反射进行取向。例如,可能旋转具有后部反射元件的探头,有或没有将其从扫描设备的主体上分离的步骤均可。可分离的探头还可以是能够承受压热的,这对于例如作为医疗设备应用于人体中的扫描器肯定是有利的。对于借助马达来实施物理移动聚焦元件的本发明实施例,有利的是将该马达放置在手枪状外形的手柄内部。

[0212] 运动、重力和磁场感测器的使用

[0213] 本发明的手持实施例优选地包括运动感测器例如加速计和/或陀螺仪。优选地,这些运动感测器是小型的,例如微电子机械系统 (MEMS) 运动感测器。运动感测器应当优选地测量所有的 3D 运动,即对于三个主坐标轴的平移和旋转。有利的是:

[0214] A) 运动感测器可检测振动和/或晃动。受到这种影响的扫描可能会或者被废弃或者通过使用图像稳定技术进行纠正。

[0215] B) 运动感测器可帮助将部分扫描相互缝合和/或登记。当扫描器的视域小于被扫描的物体时这个优势是有重大意义的。在这种情况下,将扫描器应用于物体的小区域中(每次一个),然后进行合并以获得完整扫描。在理想的情况下,运动感测器可提供要求的部分扫描的局部坐标之间的相对刚性运动转换,因为它们测量扫描设备在每个部分扫描中的相对位置。具有有限精度的运动感测器还可以提供用于部分扫描的基于软件的缝合/登记的第一推测,例如基于迭代最近点 (Iterative Closest Point) 类型的算法,这导致减小的计算时间。

[0216] C) 运动感测器(还)可以用作对伴随本发明的软件的遥控器。这些软件例如可以用于显像获得的扫描。当扫描设备此时起遥控器作用时,使用者例如可以旋转和/或全景显示视图(通过与计算机屏幕上的物体应该“移动”的相同方式移动遥控器)。特别是在临床应用中,这种手持式扫描器的双重使用优选地无需卫生方面的考虑,因为操作者避免了来自替代的手控输入设备(触屏、鼠标、键盘等等)的污染。

[0217] 即使其太不准确以致不能感测平移运动,但是 3 轴的加速计可以提供重力相对于扫描装置的方向。磁强计也可以提供关于扫描设备的方向信息,在这种情况下根据地球磁场。因此,这种设备可帮助缝合/登记并且充当遥控元件。

[0218] 本发明涉及不同方面,包括在上面和下面描述的扫描器设备及相应的方法、设备、用途和/或产品装置,每个都产生关于所述第一方面描述的一个或多个有利之处和优点,并且每个都具有一个或多个实施例,所述实施例对应于关于所述第一方面中描述的和/或所附权利要求中公开的实施例。

[0219] 特别地,这里公开的是一种用于获得和/或测量物体的至少一部分表面 3D 几何形状的方法,所述方法包括下列步骤:

- [0220] - 产生整合空间图案的探测光,
 - [0221] - 沿着光学系统的光轴将探测光向物体传输,由此用所述图案照明物体的至少一部分,
 - [0222] - 传输从物体返回到照相机的光的至少一部分,
 - [0223] - 改变图案在物体上的焦平面的位置,同时保持扫描器和物体的固定空间关系,
 - [0224] - 获得来自所述感测器元件阵列的至少一个图像,
 - [0225] - 在每个焦平面位置估计至少一个图像像素和加权函数之间的相关度,其中加权函数基于空间图案构形的信息确定,
 - [0226] - 通过分析相关度确定下列对象的(多个)准确对焦位置;
 - [0227] - 对于所述系列的焦平面位置,在照相机中多个图像像素的每一个,
 - [0228] - 对于所述系列的焦平面,在照相机中多个图像像素组的每个组,和
 - [0229] - 将准确对焦数据转换成 3D 真实世界坐标。
- [0230] 还公开了包括程序编码装置的计算机编程产品,用于当所述程序编码装置在数据处理系统上执行时,使数据处理系统执行所述方法。
- [0231] 还公开了计算机编程产品,其包括具有储存在其上的程序编码装置的计算机可读的介质。

[0232] 本发明的另一个方面涉及一种用于获得和/或测量物体的至少一部分表面的 3D 几何形状的扫描器,所述扫描器包括:

- [0233] - 至少一个容纳感测器元件阵列的照相机,
- [0234] - 用于产生探测光的装置,
- [0235] - 用于将探测光向物体传输由此照明物体的至少一部分的装置,
- [0236] - 用于传输从物体返回到照相机的光的装置,
- [0237] - 用于改变物体上的焦平面的位置的装置,
- [0238] - 用于从所述感测器元件阵列获得至少一个图像的装置,
- [0239] - 用于以下方面的装置:
 - [0240] a) 确定下列对象的(多个)准确对焦位置:
 - [0241] - 对于一系列的焦平面位置,多个感测器元件中的每一个,或
 - [0242] - 对于一系列的焦平面位置,多个感测器元件组中的每个组,和
 - [0243] b) 将准确对焦数据转换成 3D 真实世界坐标;
- [0244] 其中扫描器进一步包括配重装置,其用于配重改变焦平面位置的装置。

[0245] 还公开了一种用于获得和/或测量物体的至少一部分表面的 3D 几何形状的方法,所述方法包括下列步骤:

- [0246] - 容纳感测器元件阵列,
- [0247] - 产生探测光,
- [0248] - 将探测光向物体传输,由此照明物体的至少一部分,
- [0249] - 传输从物体返回到照相机的光,
- [0250] - 改变物体上的焦平面的位置。

- [0251] - 从所述感测器元件阵列获得至少一个图像,
- [0252] - 确定下列对象的 (多个) 准确对焦位置;
- [0253] - 对于一系列的焦平面位置, 多个感测器元件中的每一个,
- [0254] - 对于一系列的焦平面位置, 多个感测器元件组中的每个组, 和
- [0255] - 将准确对焦数据转换成 3D 真实世界坐标;
- [0256] 其中该方法进一步包括配衡用于改变焦平面位置的装置。
- [0257] 本发明的另一个方面是关于手持式 3D 扫描器, 其手柄与扫描器的主光轴呈大于 30 度的角, 以用于口腔内或耳内扫描。

附图说明

- [0258] 图 1: 根据本发明设备的第一个示例性实施例的示意图。
- [0259] 图 2: 根据本发明设备的第二个示例性实施例 (光学相关性) 的示意图。
- [0260] 图 3: 根据本发明的图案的示例性实施例的示意图。
- [0261] 图 4: 平扫描顶端的第一个示例性实施例的示意图, 平扫描顶端具有大扫描长度, 使用多个 (二向色的) 镜子和光源。
- [0262] (图 5: 删除)
- [0263] 图 6: 平扫描顶端的第三个示例性实施例的示意图, 平扫描顶端具有大扫描长度, 使用弯曲的镜子。
- [0264] 图 7: 平扫描顶端的第四个示例性实施例的示意图, 平扫描顶端具有大扫描长度, 使用衍射光栅。
- [0265] 图 8: 质量平衡的聚焦透镜扫描器的示例性实施例的示意图。
- [0266] 图 9: 同时扫描表面形状和颜色的设备的示例性实施例的示意图。
- [0267] 图 12: 用于扫描人耳外部的至少一部分和 / 或人耳耳道的一部分的设备的示例性实施例的示意图。
- [0268] 图 13(a) 和 (b); 分别显示了扫描器实施例如何能够用于扫描外耳和内耳的示意图。
- [0269] 图 14: 用于扫描窄体腔, 例如人耳的扫描器探头实施例的示意图。
- [0270] 图 15: 用于扫描器探头的镜子构形的实例。
- [0271] 图 16: 在理想的光学系统中棋盘图案的每个像素的参考信号值 / 加权值的示意图。
- [0272] 图 17: 对产生合并的参考信号过程的说明, 该信号形象化为图像。
- [0273] 图 18: 上部: 具有显示在人牙齿上的投影图案的示例性图像。下部: 在图上部中圈定范围的像素组上的一系列聚焦透镜位置的相关度。
- [0274] 图 19: 口腔内图像的示例性合并相关度图像。
- [0275] 图 20: 具有手枪状的手柄和可拆卸的顶端的手持式口腔内扫描器实例。

具体实施方式

[0276] 应当理解图中描绘的光线踪迹和透镜仅仅是为了说明的目的, 并且总体上描绘所讨论的系统中的光路。光线踪迹和透镜形状不应当被理解成在任何方面限制本发明的范

围,这些方面包括通过各种光学组件的光线或光束的幅度、方向或焦点,也包括不容许其数量、方向、形状、位置或尺寸的任何改变,除非在下面对图中描绘的示例性实施例的详细说明中特别指出。

[0277] 附图的详细说明

[0278] 功能性的手持式 3D 表面扫描器优选地应当具有下列性质:

[0279] 1) 在被扫描物体的空间中的焦阑性,

[0280] 2) 在保持焦阑性和放大率的同时移动焦平面的可能性,

[0281] 3) 仅仅在设备的手柄而没有在探头顶端涉及调整光学组件的调谐的简单的对焦配置,和

[0282] 4) 与手持式扫描设备相符的总体尺寸。

[0283] 图 1 中说明的扫描器实施例是所有组件都在外壳(头部)100 内部的手持式扫描器。扫描器头部包括可以进入腔内的顶端、光源 110、收集来自光源的光的光学器件 120、图案产生装置 130、分束器 140、图像感测器和电子设备 180,在图案、被扫描物体和图像感测器(照相机)180 之间传输和成像光的透镜系统。来自于光源 110 的光通过光学系统 150 向后和向前传送。在这个通过期间,光学系统将图案 130 成像到被扫描的物体 200 上,并进一步将被扫描的物体成像到图像感测器 181 上。透镜系统包括聚焦元件 151,可调节聚焦元件 151 以移动图案在被探测物体 200 上的聚焦成像面。实现聚焦元件的一种方式沿光轴前后物理移动单个透镜元件。设备可包括偏振光学器件 160。设备可包括折光光学器件 170,其以不同于透镜系统的光轴的方向,例如以垂直于透镜系统的光轴的方向将光导出设备。总体上,光学系统提供图案到被探测物体上的成像和从被探测物体到照相机上的成像。设备的一种应用可以是用于确定口腔内牙齿的 3D 结构,另一个应用可以是用于确定耳道和耳朵外部的 3D 形状。

[0284] 图 1 中的光轴是由通过光学系统 150 中的光源 110、光学器件 120 和透镜的直线所确定的轴。这也对应于图 1 中所示扫描器的纵轴。光路是由光源 110 到物体 200 并回到照相机 180 的光的路径。光路可改变方向,例如借助分束器 140 和折光光学器件 170。

[0285] 以如下方式调节聚焦元件:图案在被扫描物体上的图像沿光轴移动,优选地以等步幅从扫描区域的一端到另一端。当图案对固定的焦点位置以周期方式随时间变化时,物体上的准确对焦区域将显示空间变化图案。离焦区域在光变化中将显示较小对比度或没有对比度。被探测物体的 3D 表面结构通过如下方式而确定:当针对一系列不同焦点位置 300 记录相关度时,针对照相机感测器阵列中的每个感测器或对照相机感测器阵列中的每组感测器找出对应于相关度极值的面。优选地某人能够以等步幅从扫描区域的一端到另一端移动焦点位置。

[0286] 图案产生

[0287] 图案产生装置的实施例显示在图 3a 中,具有不透明遮盖件 133 的透明轮,该遮盖件 133 呈由轮中心径向伸出的辐条形式。在这个实施例中,通过用马达 131 使轮旋转来使图案随时间变化,马达 131 利用例如传动轴 132 连接到轮上。图案随时间的位置可以在旋转过程中登记,这可以通过例如使用图案轮圈上的位置编码器 134 或者从马达 131 直接获得轴位置来实现。

[0288] 图 3b 示出了图案产生装置的另一个实施例,分段光源 135,优选地为分段 LED。在

这个实施例中,将 LED 表面成像到调查的物体上。以在物体上提供已知的时变图案的方式打开和关闭多个单独的 LED 段 136。通过电线 138 将时变图案的控制电子器件 137 连接到分段光源。从而将图案整合到光源中,并且不需要单独的光源。

[0289] 图 3c 说明了应用在本发明的空间相关性实施例中的静止图案。所示的棋盘图案是优选的,因为这种规则图案的计算是最容易的。

[0290] 时间相关性

[0291] 图 1 也是对时间相关性的示例性说明,其中在物体上和 / 或物体中的图案的图像形成在照相机上。照相机中的每个单独光感测元件都感测到对应于物体上的照明图案变化的信号水平变化。在示例性的说明中,该变化是周期性的。每个单独的光感测元件的光变化将具有与图案位置有关的恒定相位偏移。

[0292] 可以通过在至少一个振荡周期中记录照相机上的 n 个图像获得相关度。 n 是大于 1 的整数。每个单独图像的图案位置与每个感测元件和记录的图像的相位偏移值相结合的记录容许利用下面的公式在照相机的每个单独感测元件中有效提取相关度:

$$[0293] \quad A_j = \sum_{i=1}^n f_{i,j} I_{i,j}$$

[0294] 这里, A_j 是感测元件 j 的估计相关度, $I_{1,j}, \dots, I_{n,j}$ 是来自感测元件 j 的 n 个记录的信号, $f_{1,j}, \dots, f_{n,j}$ 是由对每个图像记录的图案构形的了解获得的 n 个参考信号值。 f 具有两个下标 i, j 。 f 随第一个下标的变化来源于在每个图像记录过程中对图案位置的了解。 f 随着第二个下标的变化来源于对图案几何形状的了解,该图案几何形状可以在 3D 扫描之前确定。

[0295] 当焦点位置在一系列值上变化时,优选地以等步幅从扫描区域的一端到另一端,对于照相机中的单个感测器,对应于在物体上准确对焦的图案的焦点位置将通过该感测器的记录的相关度极值给出。

[0296] 空间相关性

[0297] 在空间相关性方案的一个实例中,采用与图像感测器所容许的那么高的分辨率来记录具有投影的棋盘图案的一个物体图像。因此空间相关性的方案是分析记录的图像中的像素组并提取图案中的相关度。获得的相关度极值表明了准确对焦位置。简单来说,某人可以使用具有对应于感测器上的 $n = N \times N$ 像素的片段的棋盘图案,然后分析图案的一个片段中的相关度(在一般情况下图案不必是二次项 $N \times N$)。在最佳的情况下,能将图案对齐以使得棋盘的边缘与像素的边缘重合,但是扫描原理并不是依赖于此。图 16 对于 $n = 4 \times 4 = 16$ 的情况显示出这一点。对于具有 $W \times H = 1024 \times 512$ 像素的感测器,这可对应于获得来自一个图像的 256×128 相关度点。在 $N \times N$ 像素组中提取具有下标 j 的相关度 A_j 通过下式给出:

$$[0298] \quad A_j = \sum_{i=1}^n f_{i,j} I_{i,j}$$

[0299] 其中 $f_j = (f_{1,j}, \dots, f_{n,j})$ 是由对图案构形的了解获得的参考信号向量,和 $I_j = (I_{1,j}, \dots, I_{n,j})$ 是输入信号向量。

[0300] 为了抑制光中的任何 DC 部分,我们优选地对于所有的 j 有:

$$[0301] \quad 0 = \sum_{i=1}^n f_{i,j}$$

[0302] 例如对于图 16 中描绘的情况,对于对应于图案暗部分的像素 $f_{i,j} = -1$,而反之 $f_{i,j} = +1$ 。如果图案边缘没有与像素的边缘对齐,或者如果光学系统不是完美的(因此在所有的实际应用中),则 $f_{i,j}$ 对于某些 i 将假定值在 -1 和 $+1$ 之间。对于如何确定参考函数的详细说明随后给出。

[0303] 光学相关性

[0304] 光学相关性的实例显示在图 2 中。在这个实施例中,在照相机 180 上形成图像,其为图案 130 与被探测物体 200 的叠加。在这个实施例中,图案具有可传输的性质,其中光被传输通过图案并且图案的图像被投影到物体上并再次返回。特别是这涉及光沿相反方向传输通过图案,因而借助于分束器 140 形成照相机上的图案图像。这种布置的结果是形成在照相机上的图像是图案本身和被探测物体的叠加。表达这一点的不同方式是照相机上的图像基本上是投影到物体上的图案图像与图案本身的乘积。

[0305] 在示例性的说明中变化是周期性的。在物体上的光变化和给定焦距的图案之间的相关度可以通过在大量的振荡周期上对照相机信号进行时间积分而获得,所以图案振荡时间与照相机积分时间的准确同步并不重要。当焦点位置在一系列值上变化,优选地以等步幅从扫描区域的一端到另一端时,对于照相机中的单个感测器而言,对应于在物体上准确对焦的图案的焦点位置将通过该感测器最大记录信号值给出。

[0306] 找到预定的参考函数

[0307] 以下描述对本发明的空间相关性实施例计算参考信号 f 的方法,并且该方法以程式化的方式描绘在图 17 中。

[0308] 该方法从记录棋盘图案的一系列图像开始,所述图像例如投影在平面上,优选地定向成与扫描器的光轴正交。在聚焦元件的不同位置上取景,有效覆盖所述聚焦元件的整个行程范围。优选地,以等距的位置取景。

[0309] 由于焦平面通常不是几何面,所以平面的不同区域将在不同的图像中准确对焦。三种这类图像的实例显示在图 17a-17c 中,其中 1700 是准确对焦区域。应当注意在这种程式化的图中,在准确对焦和离焦区域之间的转换分别被夸大以更清楚地说明该原理。还有,通常有比这个简单的实例中使用的仅仅三个图像多得多的图像。

[0310] 图像中的准确对焦区域作为整个所述系列的图像上具有最大强度变化(表明最大对比度)的那些区域而被找到。计算变化的区域不必与空间相关性中使用的像素组尺寸相同,但是应当足够大以包括图案的明与暗区域,并且其对于系列中的所有图像必须是相同的。

[0311] 最后,通过合成系列(17a-17c)的所有准确对焦区域产生“合并图像”(图 17d)。应当注意在真实的应用中,合并的图像通常将不是完美的黑白棋盘,而是包括中间的灰色值,这是由不完美的光学系统和与照相机感测器不完美对齐的棋盘所导致的。真实合并图像的某部分的实例显示在图 17e 中。

[0312] 在该图像中的像素强度可以理解为具有与图案的原始图像相同的尺寸的“加权图像”。换句话说,该像素值可以被解释为参考信号,并且参考向量/像素组中 n 个像素的具有下标 j 的一套加权值 $f_j = (f_{1,j}, \dots, f_{n,j})$ 可以根据像素值得到。

[0313] 为了便于计算的执行,特别是当在 FPGA 上进行时,合并的图像可以细分为像素组。然后,可以通过从每个像素强度值减去组内强度平均值而除去信号的 DC 部分。此外,

某人因此可以通过除以组内标准偏差而进行标准化。因此,处理过的加权值是参考信号的替代描述。

[0314] 由于“合并图像”并因此“加权图像”的周期性,后者可以有效压缩,因此将能实施这里描述的算法的电子器件中的存储要求减到最小。例如,PNG 算法可以用于压缩。

[0315] “相关性图像”

[0316] 基于“合并图像”和照相机在扫描过程中记录的一套图像而产生“相关性”图像。对于基于 $N \times N$ 棋盘图案的空间相关性,回想起组内相关度为:

$$[0317] \quad A_j = \sum_{i=1}^{N \times N} f_{i,j} I_{i,j}$$

[0318] 其中 $f_j = (f_{1,j}, \dots, f_{n,j})$ 是来自于合并图像的值,而 $I_j = (I_{1,j}, \dots, I_{n,j})$ 是来自于照相机上记录的图像的值。在任何 DC 消除时使用的像素分组以及可能还有在产生合并图像的标准化中使用的像素分组与上述计算中的相同。因此对于在聚焦元件的扫描过程中由扫描器记录的每个图像,有 $(H/N) \times (W/N)$ 的 A 值阵列。该阵列可以显像为图像。

[0319] 图 18(上部)显示为一个示例性相关度图像,这里是人牙齿及其边缘的一部分。由正方形 1801 标记了 6×6 像素的像素组。对于这个示例性的像素组,在聚焦元件的扫描中在所有图像上的系列相关度 A 显示在图 18 下部的图表中(十字准线)。图表上的 x 轴是聚焦元件的位置,而 y 轴显示 A 的量值。在原始系列上运行简单的高斯滤波器产生平滑系列(实线)。在图中,聚焦元件在产生实例像素组的最佳焦点的位置上。该事实既可以在照片中客观地看到,也可以作为 A 系列的最大值而定量确定。图 18 的下部中的垂直线 1802 指出了全局极值的位置因而指出了准确对焦位置的位置。应当注意在这个实例中,分别在平滑和原始系列中的最大值位置是不可目测分辨的。然而在原则上,可能并且也有利的是由平滑系列找出最大值位置,因为该位置可能在两个透镜位置之间,因此提供更高的准确性。

[0320] 可以对聚焦元件的扫描中记录的每个图像计算 A 值阵列。以与将合并图像合成相同的方式,合成所有像素组中的 A 的全局极值(在所有图像上),某人可以获得具有 $(H/N) \times (W/N)$ 尺寸的伪图像。我们称此为“合并相关性图像”。某些牙齿及牙龈的合并相关性图像的实例显示在图 19 中。正如所见,这对于显像目的是有用的。

[0321] 增加视域

[0322] 对于进入小空间如患者口腔的扫描头,需要扫描头的顶端足够小。同时从扫描头发出的光需要以不同于光轴的方向离开扫描头,例如垂直于光轴的方向。在本发明的一个实施例中,45 度的镜子用作折光光学器件 170,其将光路引导到物体上。在这个实施例中,扫描顶端的高度需要至少与扫描长度一样大。

[0323] 本发明的另一个实施例显示在图 4 中。本发明的这个实施例容许扫描顶端具有比扫描长度(图中表示为 a)更小的高度(图中表示为 b)。使用适当涂层的板 112(例如二向色滤光片)将来自两个光源 110 和 111 的光归并在一起,所述两个光源发射具有不同颜色/波长的光,所述适当涂层的板传输来自 110 的光并且反射来自 111 的光。在扫描顶端,适当涂层的板(例如二向色滤光片)171 将来自一个光源的光反射到物体上,并且将来自另一个光源的光传输到在扫描顶端末尾的镜子 172 上。在扫描过程中,焦点位置发生移动,从而使来自 110 的光用于将图案的图像投影到 171 下方的位置而同时 111 关闭。记录 171 下方区域中的物体的 3D 表面。然后关闭 110 并且打开 111,并且焦点位置发生移动,从而使来自 111 的光用于将图案的图像投影到 172 下方的位置。记录 172 下方区域中的物体的 3D 表

面。分别来自于 110 和 111 的光所覆盖的区域可部分重叠。

[0324] 容许扫描顶端具有比扫描长度（图中表示为 a）更小的高度（图中表示为 b）的另一个本发明实施例显示在图 6 中。在这个实施例中，折光光学器件 170 包括弯曲的折光镜 173，该折光镜 173 可以补充有一个或两个透镜元件 175 和 176，其表面可以是非球面的以提供修正的光学成像。

[0325] 容许扫描顶端具有比扫描长度（图中表示为 a）更小的高度（图中表示为 b）的另一个本发明实施例显示在图 7 中。在这个实施例中，折光光学器件 170 包括光栅 177，其提供失真的放大从而使图案在被扫描物体上的图像被拉伸。光栅可以是闪耀光栅。在这个实施例中光源 110 需要为单色或半单色的。

[0326] 获得投影到困难物体上的图案的高空间对比度

[0327] 在物体上的准确对焦图案图像的高空间对比度是必需的以基于照相机照片获得高相关度信号。这又是必需的以获得对应于相关度极值位置的焦点位置的良好估计。对于成功扫描的这种必需条件在具有漫射表面和可忽略的透光性的物体中是容易获得的。然而，对于某些物体，难以获得高的空间对比度，或者更一般地说，难以获得高的空间变化。

[0328] 例如，一种困难类型的物体是显示出多次散射且具有与成像到物体上的空间图案的最小特征尺寸相比而言大的光漫射长度的物体。人类牙齿就是这种物体的实例。人类的耳朵和耳道是另一个实例。可以通过将来自物体的镜面反射优先成像到照相机上而获得这些物体中改善的空间变化。本发明的实施例应用了图 1 中所示的偏振工程技术。在这个实施例中，分束器 140 是偏振光束分光器，其分别传输两种正交偏振状态的反射光，例如 S- 和 P- 偏振状态。通过透镜系统 150 传输的光因此具有特定的偏振状态。在离开设备之前用延迟板 160 改变偏振状态。优选类型的延迟板是四分之一波长的延迟板。线偏振光波在通过四分之一波长的板时转换为圆偏振光波，其中四分之一波长的板的快轴与线偏振方向呈 45 度的取向。来自于物体的镜面反射具有翻转圆偏振光波的螺旋性的性质。当镜面反射光通过四分之一波长延迟板时，偏振状态变成与入射到物体上的状态正交。例如，在下游方向上向物体传播的 S 偏振状态将作为 P 偏振状态返回。这意味着镜面反射的光波将被引导向分束器 140 中的图像感测器 181。进入物体中并且被一个或多个散射现象散射的光被去偏振，并且该光的一半将通过分束器 140 被引导向图像感测器 181。

[0329] 另一种困难类型的物体是具有闪耀或金属外观表面的物体。这对于抛光的物体或具有非常光滑表面的物体是特别真实的。一件珠宝是这种物体的实例。然而，即使非常光滑和闪耀的物体也确实显示出一定量的漫反射。在这种物体中的改进空间对比度可以通过将来自于物体的表面漫反射优先成像到照相机上而获得。在这个实施例中，分束器 140 是偏振光束分光器，其分别传输两种正交偏振状态的反射光，例如 S- 和 P- 偏振状态。通过透镜系统 150 传输的光因此具有特定的偏振状态。来自于物体的漫反射具有丧失偏振的性质。这意味着漫反射光波的一半将被以引导向分束器 140 中的图像感测器 181。进入物体中并且由镜面偏振反射的光保留其偏振状态，因此将没有光被分束器 140 以引导向图像感测器 181。

[0330] 减小由聚焦元件引起的晃动

[0331] 在扫描过程中，聚焦位置在一系列值上变化，优选由光学系统 150 中的聚焦元件 151 提供。图 8 说明了如何减小由振荡聚焦元件引起的晃动的实例。聚焦元件是安装在平

移台 153 上的透镜元件 152, 并且利用包含马达 155 的机械构造 154 沿着所述光学系统的光轴前后平移。在扫描过程中, 手持设备的质量中心由于透镜元件和支架的物理移动而发生移动。这导致在扫描过程中不希望的手持设备的晃动。如果扫描快, 例如少于一秒的扫描时间, 这种情况加重。在本发明的一个实施例中, 通过以下列方式使配重 156 沿与透镜元件相反的方向移动来消除质量中心的移动, 手持设备的质量中心保持固定。在优选的实施例中, 聚焦透镜和配重是机械连接的并且它们的相对运动通过同一个马达驱动。

[0332] 颜色测量

[0333] 彩色 3D 扫描器的实施例显示在图 9 中。三个光源 110、111 和 113 发出红色、绿色和蓝色光。光源可以是 LED 或激光。光射并在一起以重叠或基本上重叠。这可以借助于两个适当涂层的板 112 和 114 来实现。板 112 传输来自 110 的光并反射来自 111 的光。板 114 传输来自 110 和 111 的光并反射来自 113 的光。颜色测量如下进行: 对于给定的焦点位置, 投影到被探测物体上的时变图案的幅度通过上述用于每个光源的方法之一对于感测器 181 中的每个感测器元件单独进行确定。在优选的实施例中, 每次只有一个光源打开, 并且光源依次打开。在这个实施例中, 光学系统 150 可以是消色差的。在对每个光源确定了幅度之后, 焦点位置移动到下一个位置并重复这个程序。表达为例如每个表面元素的 RGB 颜色坐标的颜色可以通过适当地加权对应于最大幅度的每个颜色的幅度信号而重建。

[0334] 在本发明的一个具体实施例中, 仅仅以 P 个焦点位置的间隔登记了所有颜色的幅度; 同时选择了一种颜色用于在所有焦点位置确定幅度。P 是可以例如为 3、5 或 10 的数。这产生了低于表面拓扑结构的分辨率的颜色分辨率。通过在获得全色信息的焦点位置之间进行插值来确定被探测物体的每个表面元素的颜色。这与在许多彩色数码相机中使用的拜耳 (Bayer) 彩色方案相类似。在这个方案中, 颜色分辨率也低于空间分辨率, 并且颜色信息需要进行插值。

[0335] 3D 彩色扫描的较简单实施例并不登记所有的颜色信息并且仅仅采用具有不同颜色的两种光源。这一点的实例是牙齿扫描器, 其使用红色和蓝色光来区分硬 (牙齿) 组织和软 (牙龈) 组织。

[0336] 耳朵扫描器实施例

[0337] 图 12-15 示意说明了基于时变结构的光照明的扫描器的实施例, 其通过用普通的扫描器外部手柄和可分离的探头扫描人耳外部 (外) 和内部 (内) 而直接扫描人耳。这个实施例是有利的, 因为其使用设计为插入小腔如人耳内的探头而容许非侵入性的扫描。这通过将大量和关键的扫描器部件如扫描器照相机、光源、电子器件和聚焦光学器件放置在耳道的紧密狭窄部分之外而部分地完成。

[0338] 扫描人耳的外部 and 内部并且形成耳朵的虚拟或真实模型的能力对于设计现代的顾客特制的助听器 (例如耳套或耳模) 是重要的。如今, 耳朵的扫描在两步程序中进行, 其中首先取出耳朵的硅树脂印模, 和随后在第二步中使用外部扫描器对印模进行扫描。制造印模的程序具有几个缺点, 以下将很快对此进行描述。一个主要的缺点来自于由于制备和技术要求而导致的由有资格的临床专业人员制取的常见差质量印模。由于已知印模材料在硬化过程中膨胀, 并且当将印模从耳朵上取下时经常发生印模中的变形和产生断裂, 因此可能出现不准确性。另一个缺点是关于制取印模涉及的健康风险, 其是由于刺激和过敏反应、对鼓膜的损害和感染所导致。最后, 制模程序对于许多患者是不适的经历, 特别是对于

年轻的孩子,他们经常需要以规则间隔(例如每隔四个月)制取印模以适应耳道的变化尺寸。简而言之,如果能以非侵入性的方式扫描外耳和内耳并且获得内耳和外耳表面之间的登记,则这些缺点可以被克服。

[0339] 下列内容并不限于耳朵扫描而是可以用于扫描任何小体腔。图 12 是这种扫描器的实施例示意图。扫描器由两个主要部件组成——扫描器外部 1001 和扫描器探头 1002。可以使用扫描器外部而不使用探头以获得例如扫描耳朵外部 1102,或者耳道的第一部分直到第一弯曲所需的较大视域。扫描器外部的大视域对于获得单个扫描和高的全局准确性之间的良好登记是重要的。通过将扫描器探头 1202 装配到扫描器外部 1201 上,组合的扫描器允许扫描小和弯的腔表面,例如耳朵的内部 1203。通过这种方式并使用相同的系统,组合的扫描器外部和探头能够扫描较大的外部面积以及较小的内部面积。在图 12 中,扫描器实施例 1001 的外部由离散光源 1003(激光、LED、钨灯或其它类型)组成,其用对准光学器件 1004 进行对准。对准的光用来照明透明物体 1005(例如玻璃),透明物体上具有不透明图案,例如其上的条纹。随后用合适的光学系统将图案成像到被扫描的物体上。用类似的光学系统和照相机 1006 观测图案,其中照相机位于腔之外。通过观测由图案在扫描物体上移动产生的光振荡而由 2D 图像获得 3D 信息,光振荡包含在单个像素幅度中。

[0340] 为了便于图案的移动,在一个实施例中旋转条纹图案 1005。在另一个实施例中,条纹图案位于平移板上,该板在垂直于光轴的平面中移动,并且具有特定的振荡频率。到达和来自扫描物体的光通过分束器布置 1007 进行投影,分束器布置在一个实施例中由棱镜立方体组成,而在另一个实施例中由成角度的板或膜组成。分束器用于将光源的光沿着系统进一步传输,而同时将来自扫描物体的反射光引导回照相机,照相机位于垂直于光源和分束器的轴的轴线上。

[0341] 为了移动焦平面,扫描器外部包含聚焦光学器件,在一个实施例中其由单个可移动的透镜 1008 组成。聚焦光学器件的目的是便于整个成像系统的焦平面在要求的扫描范围中沿着光轴移动。在一个实施例中,扫描器外部 1101 的聚焦光学器件包括能够直接聚焦光的物镜,而不必使用任何另外的光学器件,如图 13a 中所示。在另一个实施例中,扫描器外部配备有设计成具有大视域的广角物镜,其例如对于扫描人耳外部 1102 足够大。

[0342] 扫描器探头的光学部分由内窥镜的光学中继系统 1009 及随后的探头物镜 1010 组成,这两者都具有足够小的直径以适合人耳的耳道。这些光学系统可由多个光学纤维和透镜组成,并且用于将来自扫描器外部的光传送和聚焦到扫描物体 1014 上(例如耳朵的内表面),以及用于将来自扫描物体的反射光对准和传送回扫描器外部。在一个实施例中,探测物镜提供条纹图案到扫描物体上的焦阑投影。焦阑投影可显著简化获得的 2D 图像到 3D 图像的数据映射。在另一个实施例中,来自探测物镜的主要光(每个光束的中心光)是离散的(非焦阑的)以为照相机提供大于零的视角,如图 13a 中所示。

[0343] 焦平面的位置由聚焦光学器件 1008 控制,并且可以在足够大的范围内移动从而至少与扫描表面 1014 重合。如以上所述,通过在不同的焦平面位置和不同的条纹图案位置收集大量的 2D 图像而获得单个扫描。当焦平面在单个像素位置与扫描表面重合,条纹图案将被投影到准确对焦的表面上并具有高对比度,由此产生像素值在时间上的大变化或幅度。因此对于每个像素,可以识别聚焦光学器件的单独设置,每个像素都将对其准确对焦。通过利用对光学系统的了解,可在单独像素的基础上将对对比度信息-焦平面位置转换

成 3D 表面信息。

[0344] 在一个实施例中,镜子布置 1011 位于探测物镜 1010 之后,镜子布置 1011 由单个反射镜子,或棱镜或多个镜子的布置组成。该布置用于将光线反射到不同于探测轴方向的观看方向。镜子布置的不同实例在图 15a-15d 中得到。在一个特别的实施例中,镜子法向和光轴之间的角度为大约 45 度,由此提供了相对于探测轴的 90 度视图——这对于观看圆角是理想的布置。透明窗口 1012 的位置与镜子相邻,并且作为探头外壳 / 壳的一部分,以容许光在探头和扫描物体之间通过,同时保持光学器件不被外部的脏颗粒污染。

[0345] 为了减小扫描器操作者所要求的探头移动,可以用马达 1013 使镜子布置旋转。在一个实施例中,镜子布置恒速旋转。通过充分旋转单个镜子,由此能够围绕探测轴以 360 度覆盖范围扫描,而不必物理移动探头。在这种情况下,要求探测窗口 1012 围绕 / 全面环绕探头从而能够在每个角度上观看。在另一个实施例中,镜子以某个旋转振荡频率发生旋转。在又一个实施例中,以某个振荡频率改变相对于探测轴倾斜的镜子布置。

[0346] 在一个特别的实施例中使用一对镜子而不是单个镜子(图 15b 和 15d)。在特殊的情况下,两面镜子的法向相互成大约 90 度的角度。使用一对镜子有助于登记单独的扫描,因为两个相对表面的信息由此同时获得。使用一对镜子的另一个有利之处是只需要 180 度的镜子旋转就可扫描全部的 360 度。使用一对镜子的扫描器方案因此可在比单个镜子构形更少的时间内提供 360 度的覆盖。

[0347] “手枪状”的手柄

[0348] 图 20 显示了具有手枪状的手柄 2001 的扫描器实施例。这种形式是特别符合人体工程的。图 20 中的扫描器被设计用于牙齿的口腔内扫描。顶端 2002 可以从扫描器的主体上拆卸并且可以是承受压热的。此外,顶端可以具有相对于扫描器主体的两个位置,即向下看(如图 20 中)和向上看。因此扫描患者的口上方和口下方对于操作者是同样舒适的。应当注意图 20 中显示的扫描器是早期的原型,其具有仅为了测试目的而装配的几个电缆。

[0349] 虽然详细描述和显示了一些实施例,但是本发明并不仅限于此,而是在下列权利要求中限定的主题的实质范围内还可以由其它方式实现。特别是,应当理解可以在不偏离本发明的范围的情况下使用其它的实施例并且进行结构和功能的改进。

[0350] 设备权利要求列举了多个装置,这些装置中的几个可以由同一个相同的硬件来实现。某些手段在彼此不同的从属权利要求中陈述或者在不同的实施例中描述的纯粹事实并不表示这些手段的合并不能有利地使用。

[0351] 应当强调的是词语“包含 / 包括”当用于本说明书中时是用来说明存在所述的特征、整数、步骤或组件,但不排除存在或另外有一个或多个其它特征、整数、步骤、组件或其组合。

[0352] 上述和以下方法的特征可以在软件中实施并且在数据处理系统或通过执行计算机可执行的指令而产生的其它处理装置上执行。该指令可以从存储介质或通过计算机网络从另一个计算机载入存储器例如 RAM 的程序编码装置。作为选择,所述特征可以通过硬件电路而不是软件或者结合软件而实施。



图1



图2

40

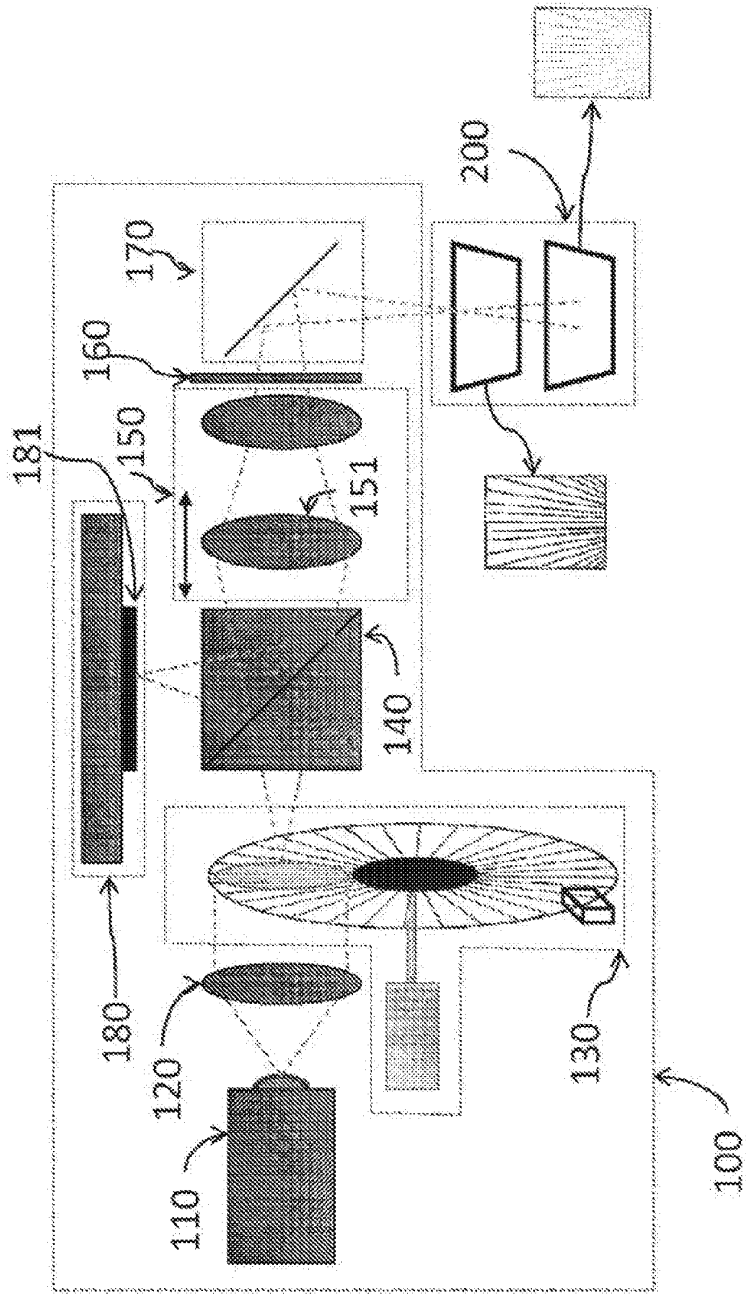

图 3a

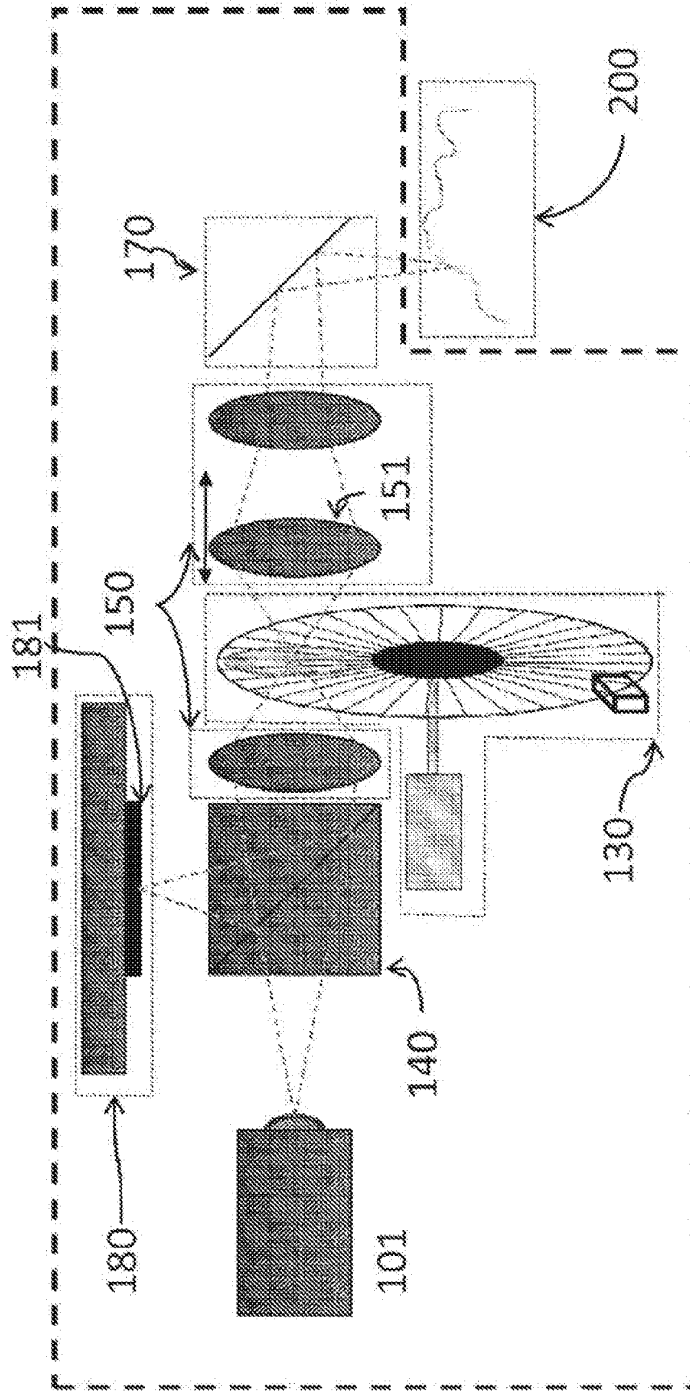

图 3b

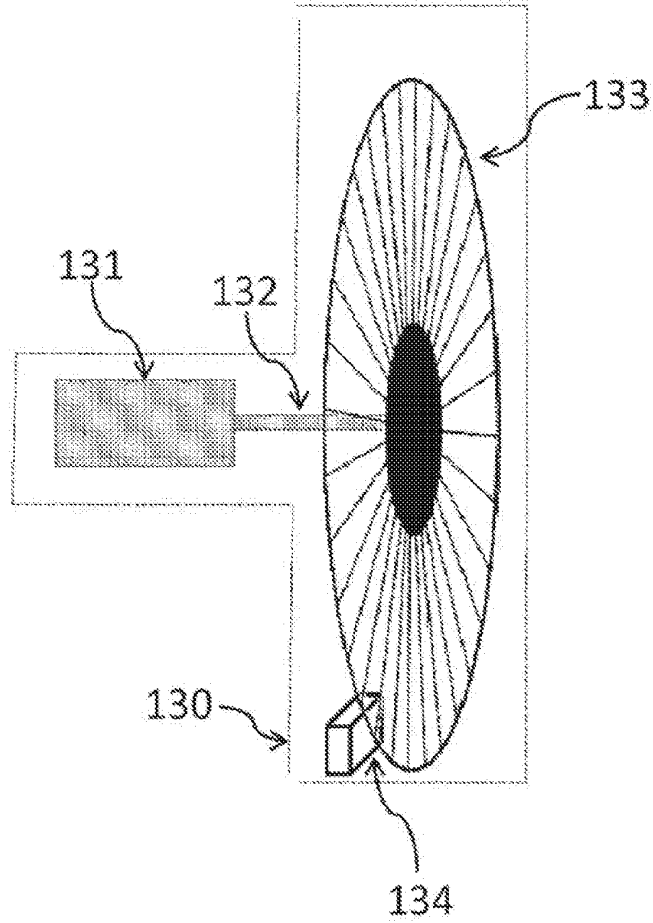

图 3c

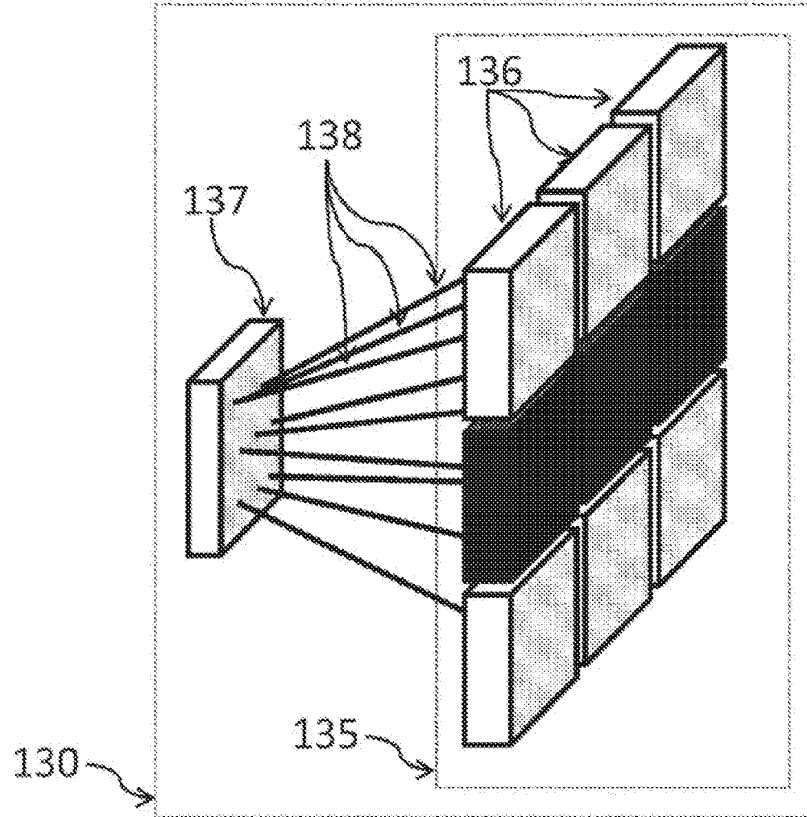

图4

44

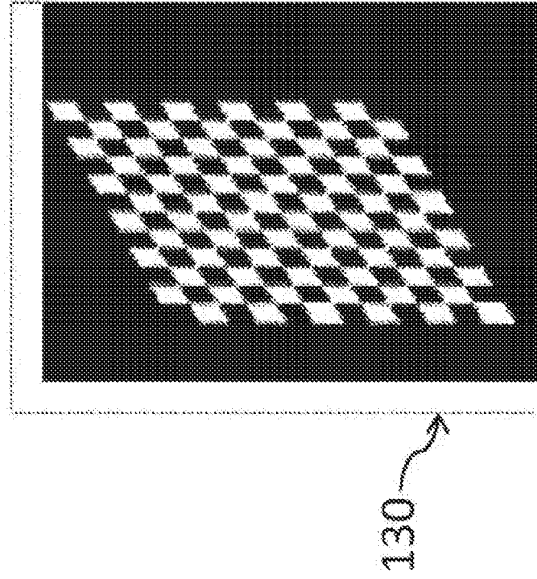

图6

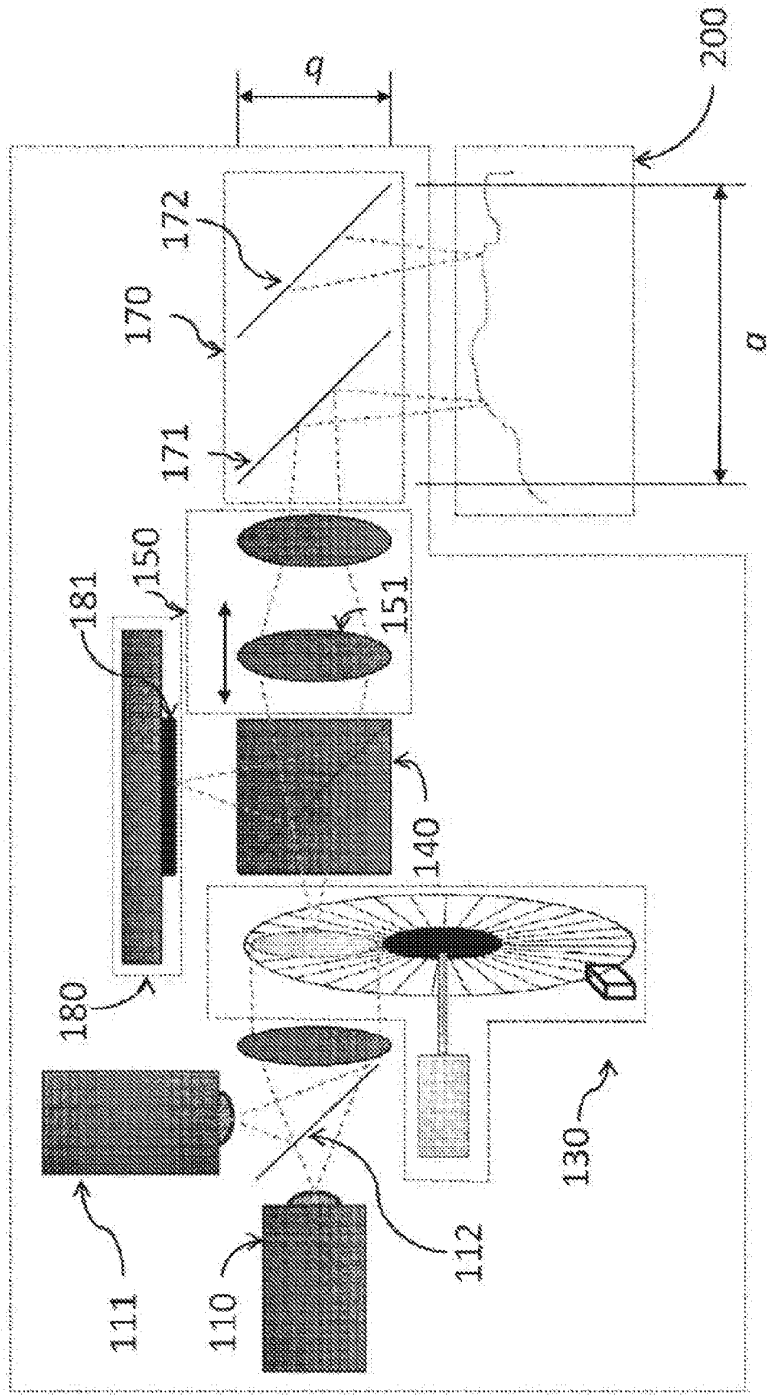

图7

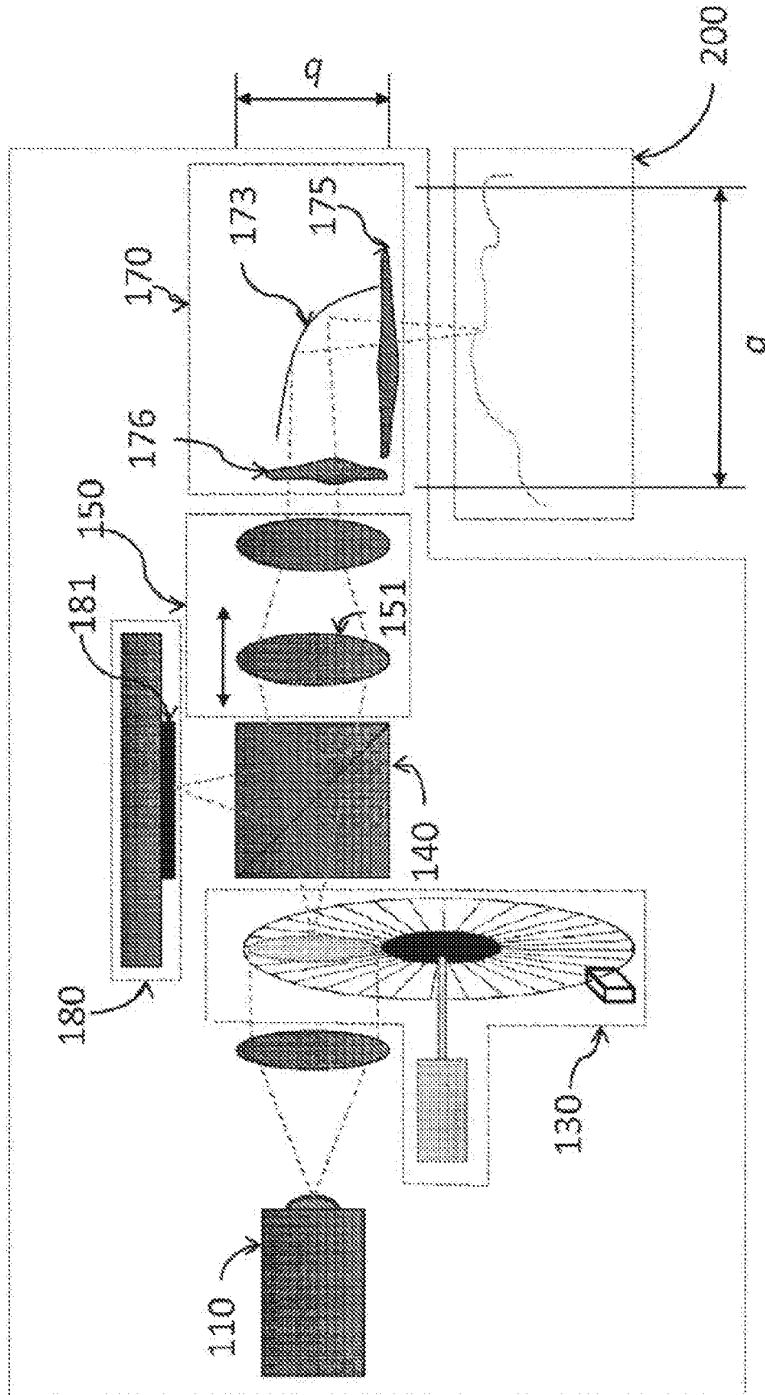

图 8

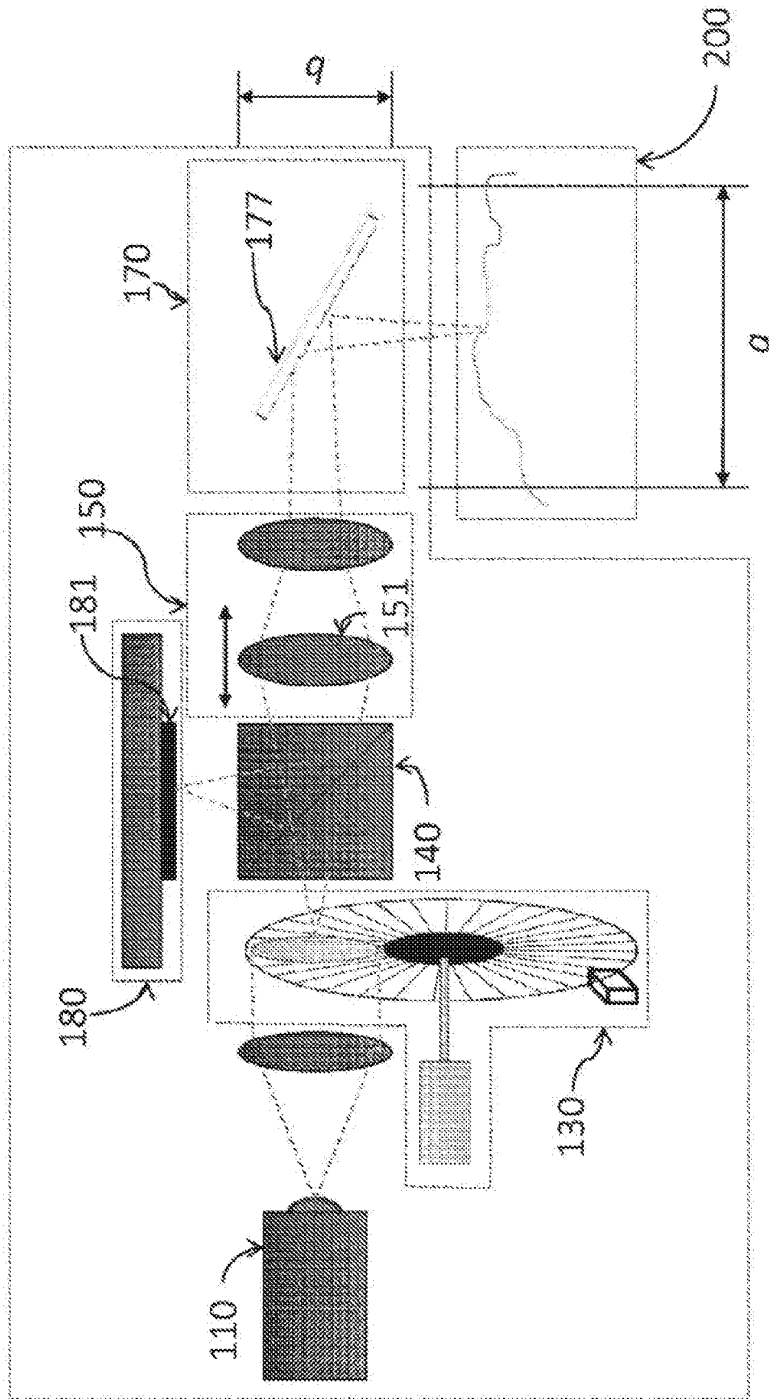

图9

9

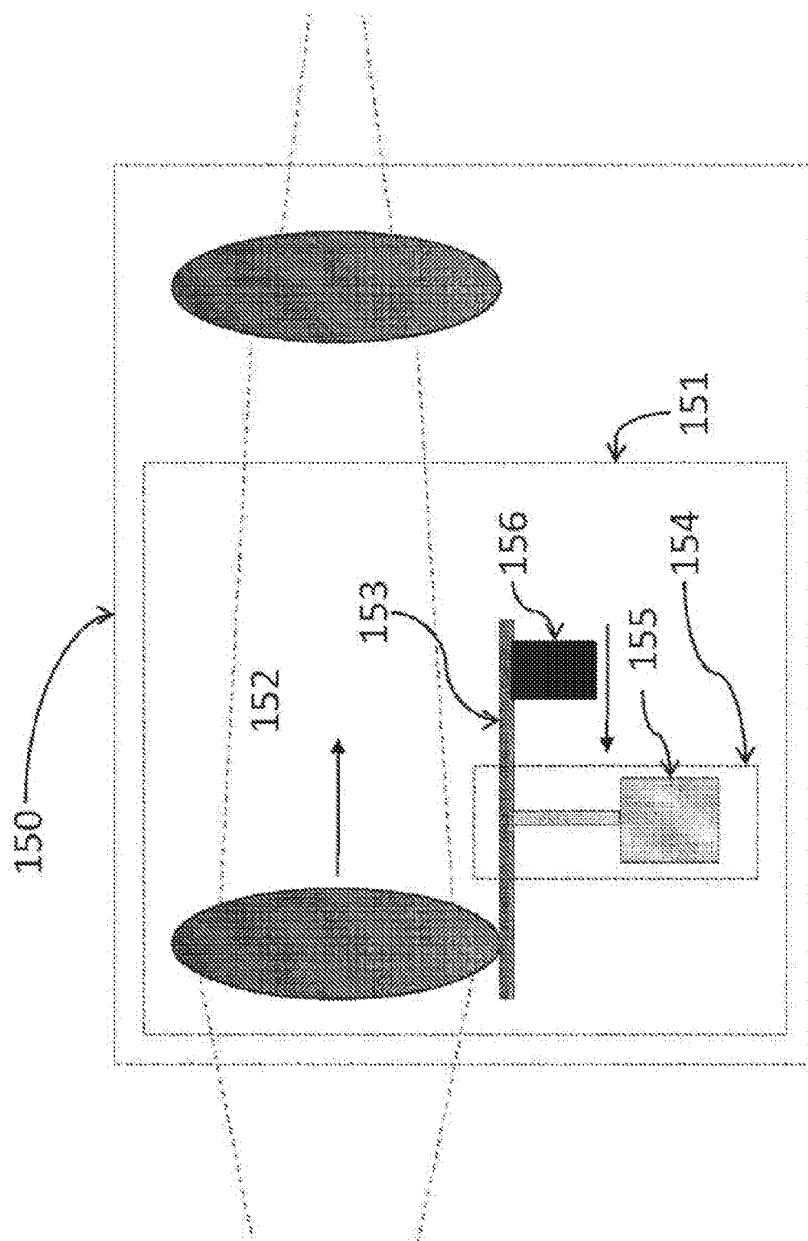

图 12

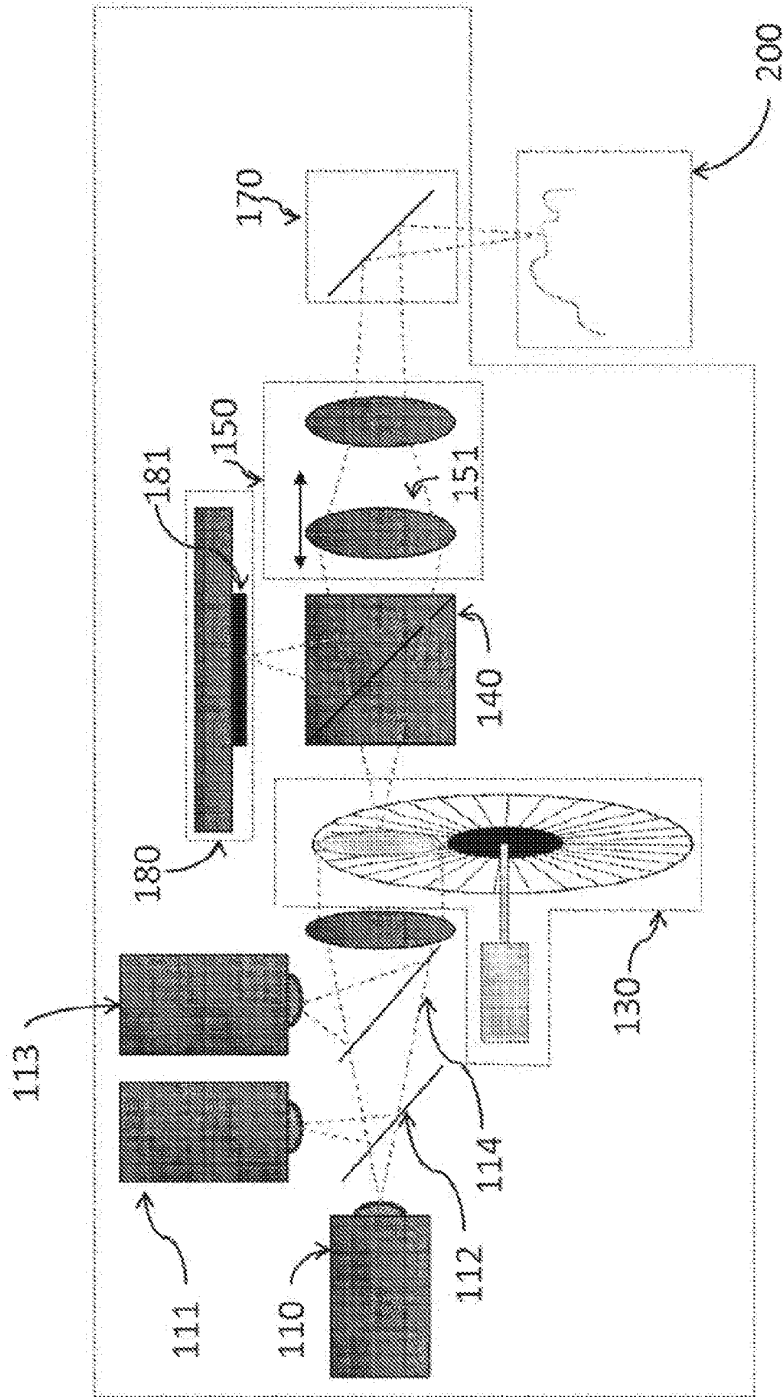

图 13a

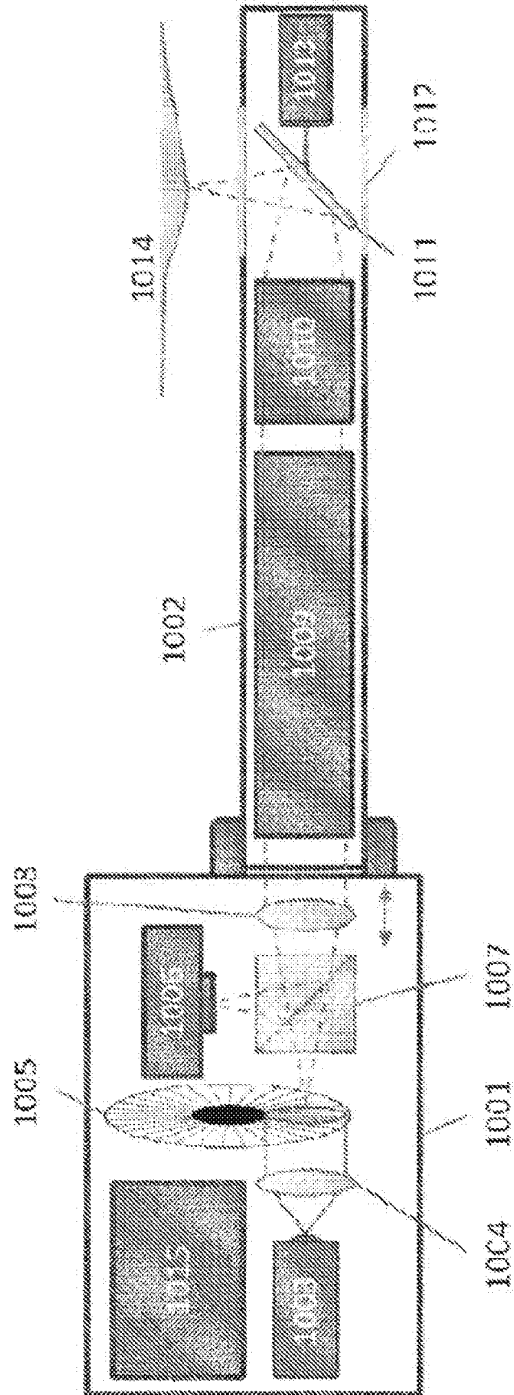

图 13b

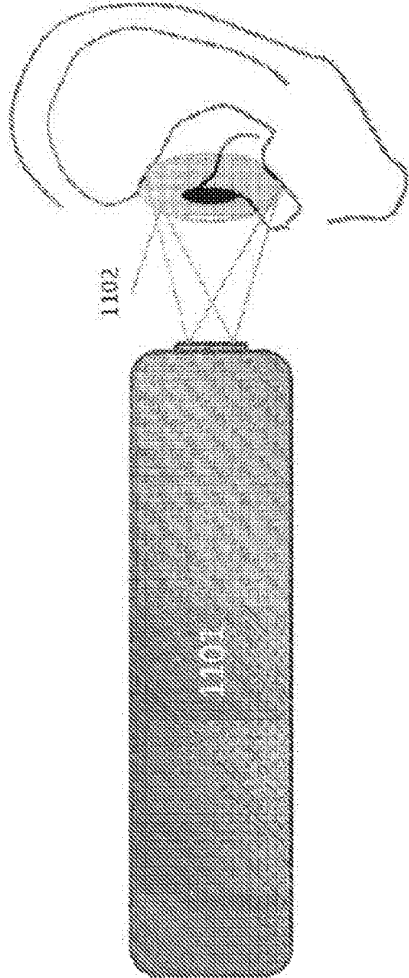

图 14

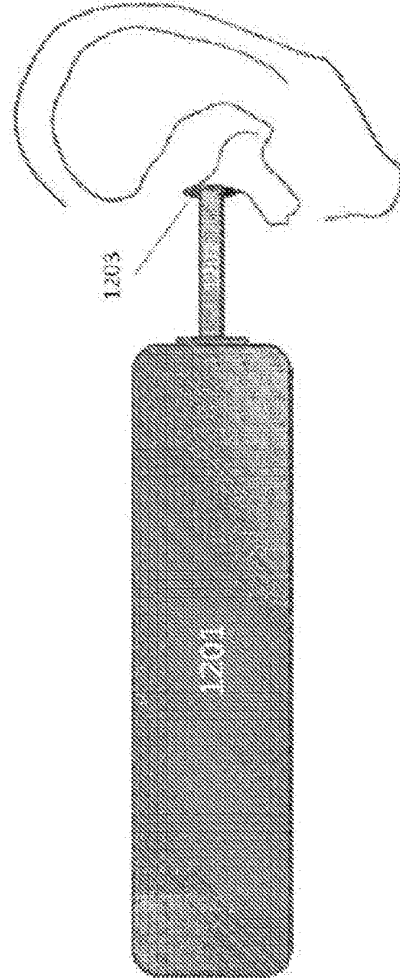

图 15b

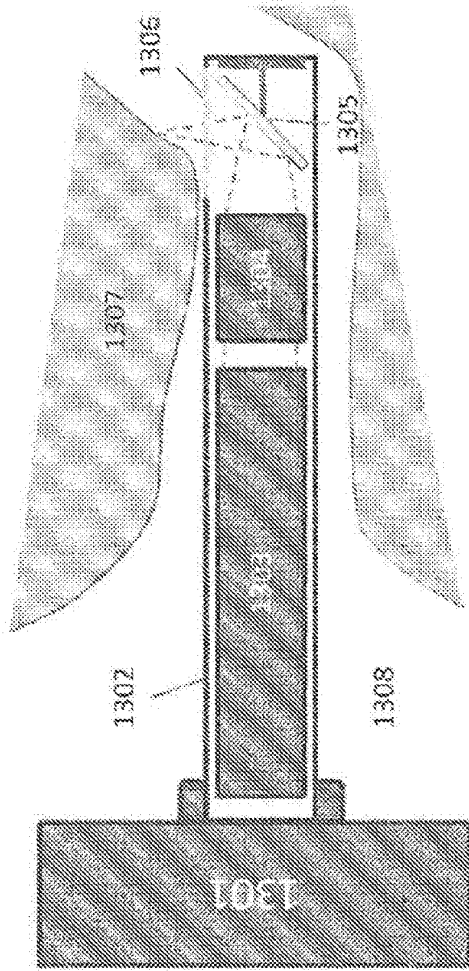

图 15a



图 15c

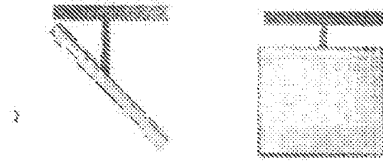

图 15d

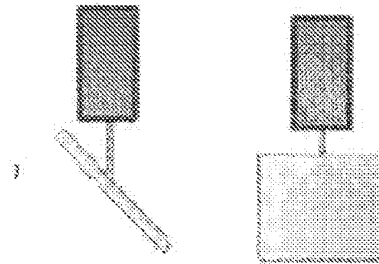

图 16

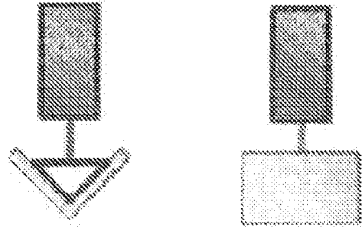

图 17a

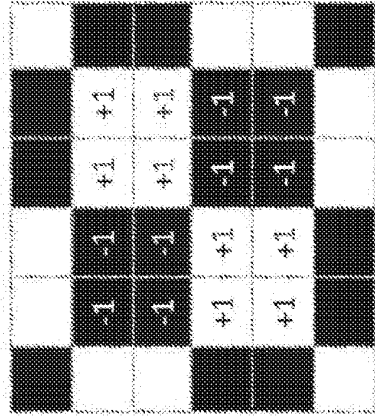

图 17b

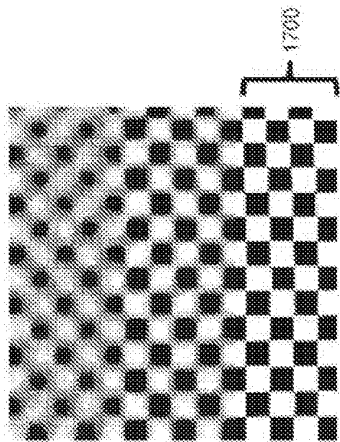

图 17c

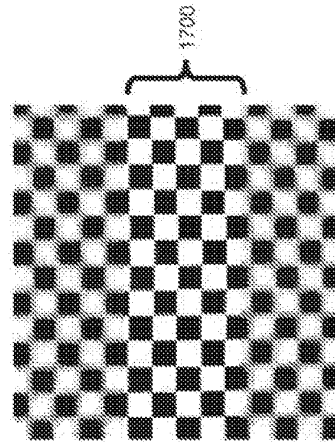

图 17d

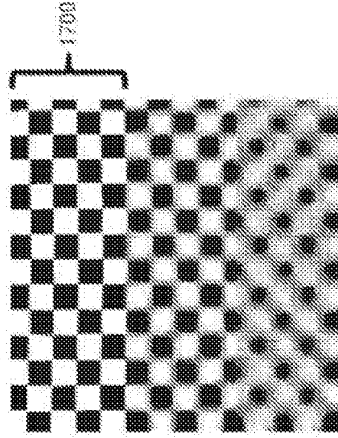

图 17e

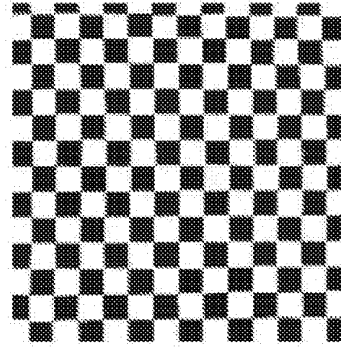

图 18

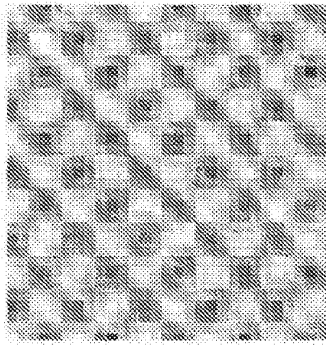

图 19

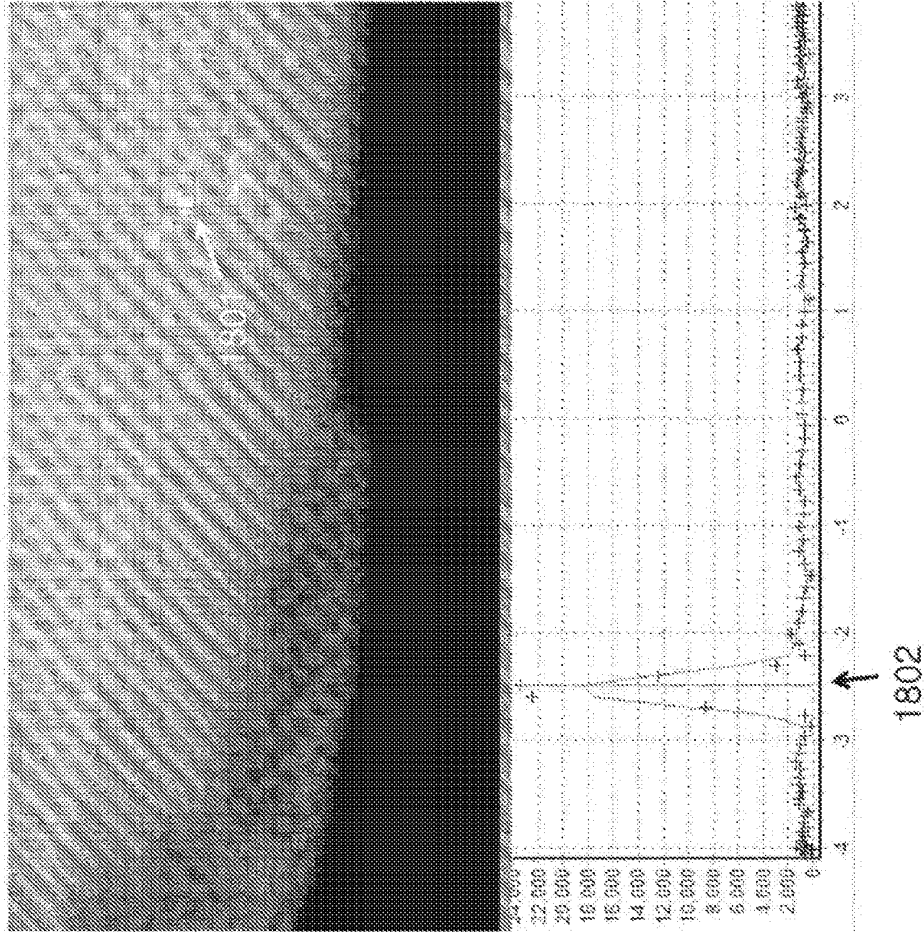

图 20

(12) INTERNATIONAL APPLICATION PUBLISHED UNDER THE PATENT COOPERATION TREATY (PCT)

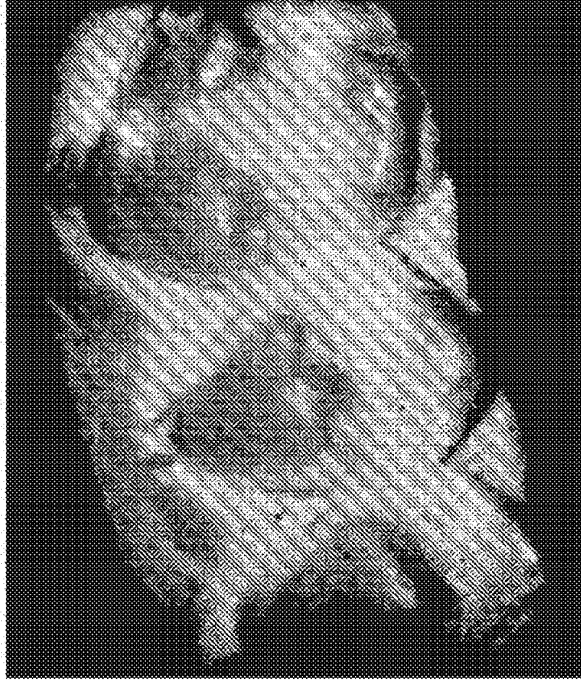
(19) World Intellectual Property Organization
International Bureau

(43) International Publication Date
19 January 2012 (19.01.2012)

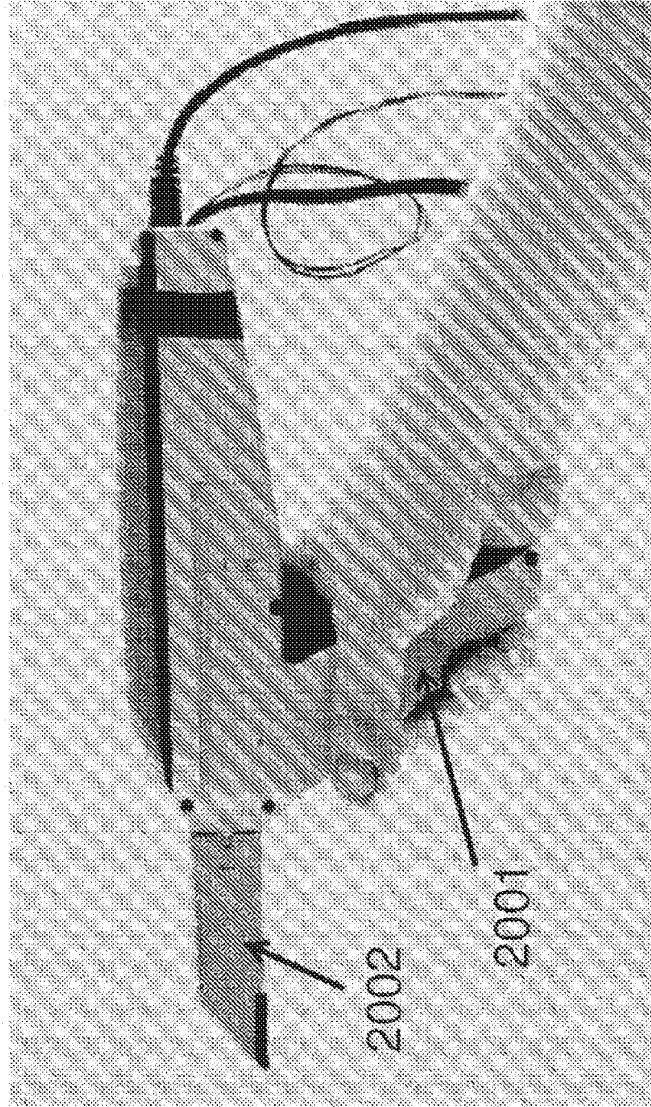
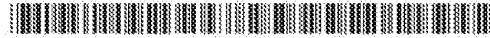

(10) International Publication Number
WO 2012/007003 A1

- (51) International Patent Classification:
A61C 13/00 (2006.01)
- (21) International Application Number:
PCT/DK2011/050273
- (22) International Filing Date:
11 July 2011 (11.07.2011)
- (25) Filing Language: English
- (26) Publication Language: English
- (30) Priority Data:
FA 2010 00617 12 July 2010 (12.07.2010) DK
61/563,735 13 July 2010 (13.07.2010) US
- (71) Applicant (for all designated States except US):
3SHAPE A/S [DK/DK]; Holmens Kanal 7, 4, DK-1060
Copenhagen K (DK).
- (72) Inventors; and
- (75) Inventors/Applicants (for US only): FISKER, Rune
[DK/DK]; Kaplevvej 87, DK-2830 Virum (DK). Clausen,
Tuls [DK/SE]; Signe Løffdahls Væg 12, S-21851
Klagshamn (SE). DEICHMANN, Nikolaj [DK/SE];

Jimolo's Væg 10, S-21851 Klagshamn (SE).
STEGMANN, Mikkel, Bille [DK/DK]; Katrinedalsvej
28, 1., DK-2720 Vanløse (DK). HOLLENBECK, Karl-
Josef [DE/DK]; Ribegade 12, 3.th., DK-2100 Copen-
hagen Ø (DK). ALLIN, Thomas Holgaard [DK/DK];
Sandvejen 20, DK-3060 Espergærde (DK). SCHJØTH,
Lars [DK/DK]; Vohundsgade 13, 4.th., DK-2200 Copen-
hagen N (DK).

(74) Agent: HØIBERG A/S; St. Kongensgade 59 A,
DK-1264 Copenhagen K (DK).

(81) Designated States (unless otherwise indicated, for every
kind of national protection available): AE, AG, AL, AM,
AO, AT, AU, AZ, BA, BB, BG, BH, BR, BW, BY, BZ,
CA, CH, CL, CN, CO, CR, CU, CZ, DE, DK, DM, DO,
DZ, EC, EE, EG, ES, FI, GB, GD, GE, GH, GM, GT,
HN, HR, HU, ID, IL, IN, IS, JP, KE, KG, KM, KN, KP,
KR, KZ, LA, LC, LK, LR, LS, LT, LU, LY, MA, MD,
ME, MG, MK, MN, MW, MX, MY, MZ, NA, NG, NI,
NO, NZ, OM, PE, PG, PH, PL, PT, RO, RS, RU, SC, SD,
SE, SG, SK, SL, SM, ST, SV, SY, TH, TJ, TM, TN, TR,
TT, TZ, UA, UG, US, UZ, VC, VN, ZA, ZM, ZW.

[Continued on next page]

(54) Title: 3D modeling of an object using textural features

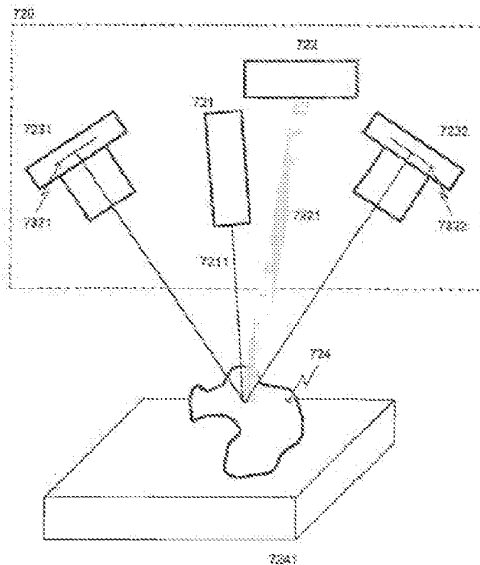

Fig. 7

(57) Abstract: 3D modeling of an object using textural fea-
tures. Disclosed is a method and a system (720) for 3D
modeling of a 3D object (724) adapted to be inserted in or
worn by a patient. The 3D modeling applies information of
one or more features from an acquired 2D digital represen-
tation comprising textural data of the location where the
3D object (724) is adapted to be arranged.

WO 2012/007003 A1



(84) Designated States (unless otherwise indicated, for every kind of regional protection available): ARIPO (BW, GH, GM, KE, LR, LS, MW, MZ, NA, SD, SL, SZ, TZ, UG, ZM, ZW), Eurasian (AM, AZ, BY, KG, KZ, MD, RU, TJ, TM), European (AL, AT, BE, BG, CH, CY, CZ, DE, DK, EE, ES, FI, FR, GB, GR, HR, HU, IE, IS, IT, LT, LU, LV, MC, MK, MT, NL, NO, PL, PT, RO, RS, SE, SI, SK,

SM, TR), OAPI (BF, BJ, CF, CG, CI, CM, GA, GN, GQ, GW, ML, MR, NE, SN, TD, TG).

Published:

— with international search report (Art. 21(3))

3D modeling of an object using textural features

This invention generally relates to a method for 3D modeling of an object adapted to be inserted in a cavity of a patient or worn by a patient. More particularly, the invention relates to acquiring digital representations of at least a part of the location where the object is adapted to be arranged.

Designing and modeling of teeth are known in the field of dental restorations. When a patient requires a dental restoration, such as crowns, bridges, abutments, or implants, the dentist will prepare the teeth e.g. a damaged tooth is grinded down to make a preparation where a crown is glued onto. An alternative treatment is to insert implants, such as titanium screws, into the jaw of the patient and mount crowns or bridges on the implants. After preparing the teeth or inserting an implant, the dentist can make an impression of the upper jaw, the lower jaw and a bite registration or a single impression in a double-sided tray, also known as triple trays. The impressions are sent to the dental technicians who manufacture the restorations e.g. the bridge. The first step to manufacture the restoration is traditionally to cast the upper and lower dental models from impressions of the upper and the lower jaw, respectively. The models are usually made of gypsum and often aligned in a dental articulator using the bite registration to simulate the real bite and chewing motion. The dental technician builds up the dental restoration inside the articulator to ensure a nice visual appearance and bite functionality.

CAD technology for manufacturing dental restorations is rapidly expanding improving quality, reducing cost and facilitating the possibility to manufacture in attractive materials otherwise not available. The first step in the CAD manufacturing process is to create a 3-dimensional model of the patient's teeth. This is traditionally done by 3D scanning one or both of the dental gypsum models. The 3-dimensional replicas of the teeth are imported into a

CAD program, where the entire dental restoration, such as a bridge substructure, is designed. The final restoration 3D design is then manufactured e.g. using a milling machine, 3D printer, rapid prototyping manufacturing or other manufacturing equipment. Accuracy requirements for the dental restorations are very high otherwise the dental restoration will not be visual appealing, fit onto the teeth, could cause pain or cause infections.

WO0019935A discloses a computer-implemented method for use in creating a digital model of an individual component of a patient's dentition, the method comprising: (a) receiving a data set that forms a three-dimensional (3D) representation of the patient's dentition; (b) applying a computer-implemented test to the data set to identify data elements that represent portions of an individual component of the patient's dentition; and (c) creating a digital model of the individual component based upon the identified data elements.

US7234937B relates to a system for use in diagnosis and planning treatment of a human patient and comprises: a general purpose computer system having a processor and a user interface; a memory accessible to said general purpose computer system storing a) a first set of digital data representing patient craniofacial image information obtained from a first imaging device, and b) a second set of digital data representing patient craniofacial image information obtained from a second image device different from said first image device, said first and second sets of data representing at least in part common craniofacial anatomical structures of said patient, at least one of said first and second sets of digital data including data representing the external visual appearance or surface configuration of the face of the patient, wherein said first and second digital data sets are each obtained at different points in time and are not captured in a correlated fashion; and a set of computer instructions stored on a machine readable storage medium accessible to said general purpose computer system,

wherein said set of instructions comprises instructions for causing said general computer system to: 1) automatically, and/or with the aid of operator interaction, superimpose said first set of digital data and said second set of digital data so as to provide a composite, combined digital representation of said craniofacial anatomical structures created from said first and second digital data sets each obtained at different points in time and not captured in a correlated fashion in a common coordinate system; wherein said set of instructions comprise instructions for creating a virtual 3D face at least from a portion of said craniofacial anatomical structures using an active model matching strategy; 2) display said composite, combined digital representation of said craniofacial anatomical structures, including said virtual 3D face, to a user of said system.

US2009133260A discloses systems and methods to fabricate a restorative prosthesis. The system includes a scanner to intra orally capture color and translucency information along with a three dimensional (3D) shape of the dentition being reconstructed. The system also includes a computer aided design (CAD) module to receive the color and translucency information and the 3D shape to render a color accurate representation of the prosthesis for review, wherein the color, translucency and surface information is combined in a single digital prescription which is electronically transferred to a laboratory or CAD/CAM system for fabrication. The system provides the capability for 3D shape, color and translucency characteristics of the final prosthesis to be measured and quantitatively compared to the prescribed requirements.

However, it remains a problem to improve and expand the use of geometrical data and textural data for patient related technology.

Disclosed is a method for 3D modeling of a 3D object adapted to be inserted in or worn by a patient, wherein the method comprises :

- 5 - acquiring a 3D digital representation of at least a part of the location where the 3D object is adapted to be arranged, where the 3D digital representation comprises geometrical data of the location;
- acquiring a 2D digital representation of at least a part of the location where the object is adapted to be arranged, where the 2D digital representation comprises textural data relating to one or more features of the location;
- 10 where a desired coverage of the location is obtained by acquiring each of the 2D digital representation comprising textural data and the 3D digital representation comprising geometrical data from one or more different viewpoints relative to the location;
- aligning the 2D digital representation comprising textural data and the 3D
15 digital representation comprising geometrical data;
- combining at least a part of the 2D digital representation comprising textural data and the 3D digital representation comprising geometrical data to obtain a combined 3D digital representation comprising both geometrical data and textural data of the location;
- 20 - visualizing the combined 3D representation comprising the geometrical data and the textural data of the location; and
- 3D modeling the 3D object such that the modeled 3D object is adapted to be inserted in or worn by a patient, where said 3D modeling applies information of the one or more features from the acquired 2D digital
25 representation comprising textural data.

Disclosed is a method for 3D modeling of a 3D object adapted to be inserted in or worn by a patient, wherein the method comprises the steps of:

- acquiring a 3D digital representation of at least a part of the location where the object is adapted to be arranged, where the 3D digital representation comprises geometrical data of the location;

5 - acquiring a 2D digital representation of at least a part of the location where the object is adapted to be arranged, where the 2D digital representation comprises textural data of the location;

10 where the acquisition of the 2D digital representation comprising textural data and 3D digital representation comprising geometrical data is performed by repositioning the location and acquisition means relative to each other for obtaining a desired coverage of the location;

- aligning and combining at least part of the 2D digital representation comprising textural data and the 3D digital representation comprising geometrical data to obtain a combined 3D digital representation comprising both geometrical data and textural data of the location;

15 - visualizing the combined 3D representation comprising the geometrical data and the textural data of the location; and

- applying information of one or more features from the 2D digital representation comprising textural data of the location, when modeling the 3D object.

20

In some embodiments, the location is automatically repositioned relative to an acquisition unit during the acquisition of the 2D digital representation comprising textural data and during the acquisition of the 3D digital representation comprising geometrical data, such that at least one of the
25 digital representations is acquired automatically from a number of different viewpoints and the desired coverage is obtained.

Disclosed is a method for 3D modeling of a 3D object adapted to be inserted
30 in or worn by a patient, wherein the method comprises :

- acquiring a 3D digital representation of at least a part of the location where the 3D object is adapted to be arranged, where the 3D digital representation comprises geometrical data of the location;

5 - acquiring a 2D digital representation of at least a part of the location where the object is adapted to be arranged, where the 2D digital representation comprises textural data relating to one or more features of the location;

10 where a desired coverage of the location is obtained by acquiring each of the 2D digital representation comprising textural data and the 3D digital representation comprising geometrical data from one or more different viewpoints relative to the location;

- aligning the 2D digital representation comprising textural data and the 3D digital representation comprising geometrical data; and

15 - 3D modeling the 3D object such that the modeled 3D object is adapted to be inserted in or worn by a patient, where said 3D modeling applies information of the one or more features from the acquired 2D digital representation comprising textural data.

20 In some embodiments, at least a part of the 2D digital representation comprising textural data and the 3D digital representation comprising geometrical data are combined to obtain a combined 3D digital representation comprising both geometrical data and textural data of the location, and where the method comprises visualizing the combined 3D representation comprising the geometrical data and the textural data of the
25 location.

Disclosed is a system for 3D modeling of a 3D object adapted to be inserted in or worn by a patient, wherein the system comprises:

30

- an illumination unit configured for illuminating at least part of a scan volume of the system;
- an acquisition unit configured for acquiring a 2D digital representation comprising textural data and a 3D digital representation comprising geometrical data of a location arranged in the scan volume;
- 5 - a first digital signal processor unit configured for:
 - analyzing the acquired 2D digital representations and 3D digital representations,
 - aligning the 2D digital representation and the 3D digital representation;
 - 10 and
 - combining at least part of the 2D digital representation and the 3D digital representation to obtain a combined 3D digital representation comprising both geometrical data and textural data of the location;
- a visualization device for visualizing the combined 3D representation comprising the geometrical data and the textural data of the location;
- 15 - a second digital signal processor unit configured for 3D modeling the 3D object such that the modeled 3D object is adapted to be inserted in or worn by a patient, where said 3D modeling comprises applying information from the acquired 2D digital representation.
- 20

In the context of the present invention, the phrase "scan volume" may refer to the volume in which a location can be illuminated with light from the light source(s) and light reflected from the location can be received by the cameras, such that the 2D digital representation and the 3D digital representation can be acquired of a location arranged in the scan volume.

25

In the context of the present invention, the phrase "applying information of one or more features from the 2D digital representation" may refer to case

where the 2D digital representation provides the information of the one or more features.

The feature may be part of the location or defined on the location, a physical model or an impression of the location, and the acquired 2D digital representation comprising texture data may provide the information of the one or more features.

In the context of the present invention, the phrases "object" and "3D object" may be used interchangeably.

In the context of the present invention, the phrases "modeling" and "3D modeling" may be used interchangeably.

A feature having a geometry that allows the feature to be identified in a digital representation of the location may be referred to as a geometrical feature.

A feature having a texture that allows the feature to be identified in a digital representation of the location may be referred to as a textural feature.

A feature may have both a geometry and a texture. A feature may thus both be referred to as a geometrical feature and a textural feature when the feature has both a geometry and a texture that allows the feature to be identified in a digital representation of the location.

The location may be the part or at the part of the patient's body where the 3D object adapted to be inserted in or worn by the patient

In the context of the present invention, the phrase "a feature of the location" may refer to situations where the feature is an integrated part of the location, such as e.g. the margin line of a tooth prepared for a restoration, to situations where the feature is defined directly on the location, such e.g. a part of an orthodontic appliance or a line drawn on a patient's teeth by a dental

technician, or situations where the feature is defined on a physical model or an impression of the location, such as a line drawn on a gypsum model of a set of teeth.

5 The phrase "the location" may refer to the location itself, a physical model of the location or an impression of the location. For example may the phrase "acquiring a 2D digital representation of the location" refer to the situation where a 2D digital representation is acquired of the location, of a physical model of the location, or of an impression of the location.

10

The phrase "textural data of the location" may accordingly refer to situations where the feature having a texture is an integrated part of the location, and where the features is defined by e.g. a dental technician directly on the location or on a physical model or an impression of the location. For example, one feature may be a colored line drawn on a physical model of a set of teeth, where the feature is a boundary of a removable partial denture, and the texture of the feature is the color in which the boundary is defined. The feature is hence not an integrated part of the location, i.e. the patients mouth, but is defined later on the physical model. In the context of the present invention, the drawn line may still be considered to be a feature of the location.

15

The 2D digital representation comprising textural data of the location may comprise one or more 2D images of the location or of a physical model or an impression of the location. The one or more 2D images may be acquired from the same or from different viewpoints relative to the location.

25

The 2D digital representation comprising textural data may be acquired from the same viewpoints as the 3D digital representation comprising geometrical data. This may allow for a relatively straight forward alignment of the 2D digital representation and the 3D digital representation.

30

The 2D digital representation comprising textural data may be acquired from viewpoints that are not the same as the viewpoints from which the 3D digital representation comprising geometrical data is acquired.

- 5 A 2D image comprising data relating to the texture of the location may be referred to as a textural image or a texture image.

Consequently, it is an advantage that features from the 2D digital representation comprising textural data of a location can be used for
10 facilitating 3D modeling of an object which is adapted to be arranged in that location. When using textural data of the location when modeling the object, the result of the modeling may be improved because different types of data are used, whereby different types of features of the location can be detected and accounted for in the modeling process of the object.

15

Texture is defined as the feel, shape, and look of the surface of the location, thus texture may comprise the smoothness, roughness, softness, color etc. of the location. Texture can refer to the properties held and sensations caused by the external surface of the location received through the sense of
20 touch. Texture can also be used to describe the feel of non-tactile sensations. Texture can comprise a pattern, color or other visual properties of the surface of the location. Thus textural data is data describing the texture of the surface of the location.

25 Geometry is defined as the size, shape, relative position of features, and the properties of space, and does therefore concern lengths, areas and volumes of the location. Thus geometrical data is data describing the geometry of the surface of the location.

30 The 2D digital representation comprising textural data and the 3D digital representation comprising geometrical data of the location can be acquired

from any viewpoint by means of repositioning the location and acquisition means, such as light source and camera used for acquiring the digital representations, relative to each other. The repositioning may be performed automatically using at least a two-axis motion system in e.g. a scanner. Thus
5 the scanner may comprise a two-axis or three-axis motion system adapted to perform acquisition automatically of the digital representations of the location from any viewpoint.

Thus it may be an advantage that the same motion system is used for repositioning the location for acquisition of both geometrical and textural
10 data. The motion system may be arranged in a 3D scanner into which a model or an impression to be scanned is placed. The motion system may perform translational and/or rotational movement of the model or impression or of the acquisition means, i.e. the light source and/or the camera for acquiring the 2D digital representation comprising textural data and the 3D
15 digital representation comprising geometrical data. Thus the repositioning may be of the location for which data are being captured, e.g. the model or impression, and/or the repositioning may be of the acquisition means, light source(s) and camera. When having two or three axes in the motion system, the model or impression can be scanned both from the sides and from the
20 top.

A desired coverage of the location may be full coverage of the entire location or of part of the location, or just coverage of a specific area of the location. A desired coverage may be obtained by capturing e.g. three or four textural
25 images, which can then be assembled into a composite textural image. More or less textural images may be captured for obtaining a desired coverage.

The aligning and the combining may describe how the two digital representations, the 3D digital representations comprising geometrical data and the 2D digital representations comprising textural data of the location,
30

are processed in order to obtain a combined 3D digital representation comprising the geometrical and the textural data.

5 Alignment may be defined as the adjustment of a digital representation of a location in relation with another digital representation of the location, such that structures of the digital representations are coinciding. Thus common or alike structures of the 3D digital representation comprising geometrical data of the location and the 2D digital representation comprising textural data of the location are aligned.

10

Aligning and combining the representations may improve the visualization and the precision of feature detection.

In the context of the present invention, the phrase "visualizing the combined 3D representation" may refer to a visualization of all data provided by the combined 3D representation or to a visualization of a part of the data provided by the combined 3D representation. The visualized combined 3D representation may hence provide a visualization of the extracted information rather than all the data which can be provided from the 2D digital representation.

20

Applying the information of the one or more textural features of the location, when modeling the object, can be defined as that when modeling the object which is adapted to be inserted, worn or arranged in the location, the information of the textural features of the location is used such that the object fits into the location taking account of the textural features of the location. Fitting of the object may mean that the insertion or wearing of the object does not cause pain for the patient, and that the insertion or wear of the object is esthetically pleasing.

30 Within dentistry, modeling of an object may comprise modeling of one or more dental restorations or restoration substructures, modeling of one or

more implants or implant abutments, modeling orthodontic appliances or modeling orthodontic movement of one or more teeth, modeling a denture, e.g. a full or partial fixed or removable partial denture, or modeling one or more teeth in a denture.

5 Thus the modeling may comprise modeling of restorations, orthodontic appliances, implants, dentures etc. When the 3D computer-aided design (CAD) modeling comprises for example restorations, the virtually modeled restorations, such as crowns and bridges, can be manufactured by means of computer-aided manufacturing (CAM), and the manufactured restorations or
10 appliance can then eventually be inserted into the patient's mouth by a dentist.

The step of applying the information of the one or more features of the location when modeling the object and other steps of the method may be
15 performed digitally on a computer and shown on a user interface such as a screen, such that the user or operator obtains a visual representation of the data sets and the different operations performed on the data sets, and the operator can then perform, finalize or check the modeling of the object.

20 The method may comprise manufacturing of the modeled 3D object and/or treatment planning of the location using one or more objects manufactured by means of the method.

Disclosed is also a method of manufacturing a 3D object adapted to be
25 inserted in or worn by a patient, where the method of manufacturing comprises the steps of the method for 3D modeling of the 3D object and a step of manufacturing the modeled 3D object.

As an alternative to the wording acquiring a digital representation of at least a
30 part of the location where the object is adapted to be arranged, the method

may comprise acquiring a digital representation of the location where the object is adapted to be arranged.

The 3D digital representation of the location and the 3D model of the 3D object may be by a triangular-based representation, where 3D surface are
5 parameterized by a number of vertices, which are connected by triangles.

Thus the geometrical scans are surface scans providing a surface representation. When modeling the object for fitting into the location, it is thus the surface of the object which is being modeled, or the modeling is performed on the surface of the object or outside the surface of the object.
10 For performing modeling outside the surface, an offset of the surface may be made digitally. In the offset a copy of the surface is placed a distance from the surface, such that modeling can be performed on a shape similar to the surface shape, but without modeling the object surface itself.

In e.g. CT scans, a volume is scanned and thus a volumetric representation
15 and not a surface representation is made.

WO0019935 described above discloses a method of obtaining data sets that forms 3D representations of the patient's dentition and to identify data elements representing individual components, where the individual component can be an individual tooth or gum tissue. Thus that method is
20 concerned with 3D representations for identifying e.g. a individual tooth and thus not concerned with the detection of features of the tooth, e.g. detected from a 2D representation. The method is used for creating orthodontic appliances to implement a treatment plan.

US7234937 described above discloses a system for storing and combining
25 different data representations of craniofacial image information of a patient including external visual appearance or surface configuration of the face of the patient for creating a virtual 3D face. Thus this document relates to

craniofacial image information, and the document does for example not disclose using information of features or modeling of an object.

5 In US2009133260A also described above, the color and translucency information and the 3D shape is used to render a color accurate representation of the prosthesis for review, such that the user can review whether the color of the prosthesis is correct.

10 US2004107080 relates to manufacture of ear pieces and discloses a method for computer-assisted modelling of customised earpieces comprising at least one part being individually matched to an auditory canal and/or a meatus, where the method comprises a number of steps including the step of: a) obtaining a three-dimensional computer model, 3D-model, of the location, i.e. of at least part of the auditory canal, where the 3D-model of the location has
15 an outer surface. The document also discloses that in some embodiments an impression of the ear or auditory canal, which is used to generate the 3D digital representation of the canal, is scanned such that a texture scan, including a colour scan, is provided. Furthermore, in some embodiments texture marked on the impression is used for initial arrangement, and in some
20 embodiments the method comprises assigning colours and/or texturing to the surface of the shell. US2004107080 does for example not disclose that the acquisition of the 2D digital representation comprising textural data and 3D digital representation comprising geometrical data are performed by automatically repositioning the location and acquisition means relative to
25 each other for obtaining a desired coverage of the location. Furthermore, the document does not disclose a combined and aligned 3D digital representation.

30 In some embodiment, the method comprises extracting the information of the one or more features from the 2D digital representation comprising textural data.

Thus information of the one or more features may be extracted before applying the information of the features, when modeling the 3D object.

5 In some embodiments extracting the information of the one or more features is performed automatically.

Automatically extracting information of one or more features of the location may be defined as that one or more of the features of the location is automatically detected from the 2D digital representation comprising textural data.

10

The information may be extracted from features that are defined using a rather complex pattern on the location. A feature may for example be defined using a closed loop to mark the edges of the feature and number of intersecting lines arranged to form a grid within this edge. A feature may also
15 be defined using a line comprising a number of disjunct line segments. For a line comprising a number of disjunct line segments, the full line may be formed by joining the line segments. This may be realized by estimating the gradients of neighboring line segment at the ends facing each other. When the gradient vectors are substantially parallel, the two line segments are
20 possibly sections of the same line, and can hence be virtually joined. When a number of intersecting lines form a grid, the gradients of the line segments between the intersections may be determined and the evaluation of the relative arrangement of the lines in the intersections may comprise identifying the different parts of the intersection from the gradient of the lines between
25 the intersections.

Alternatively, the extraction of information of the one or more features is performed manually by the operator.

In some embodiments the method comprises translating one or more 2D features from the 2D digital representation comprising textural data into 3D features.

It may be an advantage that features from the 2D digital representation can
5 be transformed into 3D features, since hereby the information from the 2D digital representation can be applied in the 3D modeling of the 3D object. The one or more 2D features may comprise a 2D point, a 2D curve or a 2D spline. The 3D feature may comprise a 3D point, a 3D curve or a 3D spline, such as a 3D spline extracted from the textural data of the 2D
10 digital representation.

In the context of the present invention, the phrase "a 2D feature" may refer to the shape of a feature or the location as captured in one 2D image of the 2D digital representation comprising textural data. Each of these 2D images may
15 comprise part of the information of the feature and this part may be extracted as said 2D feature. The combining may comprise projecting the 2D features from one or more 2D images onto the 3D digital representation. The 2D features may be translated into 3D features based on a combined 3D digital representation, where the combined 3D digital representation may comprise
20 the 3D digital representation onto which the 2D features from one or more 2D images of the 2D digital representation are projected. The information of the 2D digital representation may be the 3D feature, such that the 3D modeling applies the 3D feature.

25 In some embodiments combining the 2D digital representation and the 3D digital representation to obtain a combined 3D digital representation comprises projecting extracted information from the 2D digital representation onto the 3D digital representation.

Thus combining the two representations may comprise projecting one of the
30 representations onto the other representation, for example projecting the 2D

digital representation comprising textural data of the location onto the 3D digital representation comprising geometrical data of the location.

5 A system for acquiring the 3D digital representation comprising geometrical data and the 2D digital representation comprising textural data may comprise several components such as one or more illumination units, acquisition units, and a positioning unit for translation and/or rotation the location relative to the illumination and acquisition units. A straightforward projection of a part of the 2D digital representation onto the 3D digital representation of the location
10 formed from said 3D digital representation is possible when detailed knowledge of the arrangement of the location and the units of the system is available. In some embodiments, the system is thoroughly characterized to provide this knowledge and the relative arrangement of e.g. the positioning units, the light sources of the illumination unit and the cameras of the acquisition unit is hence known for each acquired digital representation or part
15 of a digital representation. The relative positions of the acquisition units and the location can thus be identified for each acquired part of the 2D digital representation and the acquired 2D digital representation or the parts of the 2D digital representation can straightforward be projected onto the 3D digital.
20 One way of proving a precise projection of 2D digital representations of the the 3D digital representation is to integrate a virtual model of the system in the software, such that the orientation of the location relative to the camera(s) used for acquiring the 2D images of the 2D digital representation is known for each acquired 2D image of the 2D digital representation. The software can
25 then project the 2D images or parts of the 2D images of the 2D digital representation onto the 3D digital representation. The software may also be configured for implementing other steps of the method according to the present invention. Lens distortion may also be taken into account and e.g. be included in the virtual model of the system.

In some embodiments the 3D digital representation is acquired by scanning a physical model of the location, by scanning an impression of the location, and/or by performing a direct scanning of the location.

When the 2D digital representation is provided by acquiring 2D images of a physical model or an impression of the location, the feature may be defined
5 on the physical model or an impression of the location prior to acquiring the 2D images. That is, the feature may not be part of the location but something which is added prior to the acquisition of the 2D digital representation. The feature may also be something which is added to the location prior to
10 obtaining a physical model or impression of the location or prior to a direct acquisition of the 2D digital representation.

In the context of the present invention, the phrase "acquiring a 2D digital representation of at least a part of the location where the object is adapted to
15 be arranged, where the 2D digital representation comprises textural data of the location" may also refer to the case where the textural data of the location are defined on a physical model or an impression of the location or directly on the location prior to a direct scanning of the location. The textural data may be defined by an operator, such as a dental technician, for example by
20 drawing features on a physical model of the location.

In some embodiments, acquiring the 3D digital representation comprising geometrical data of the location and the 2D digital representation comprising textural data of the location is performed by means of a system adapted for
25 acquiring geometrical data and textural data.

The system may comprise an acquisition unit configured for acquiring the digital representations of the location and a positioning unit configured for positioning the location relative to the acquisition unit, and the method
30 comprises arranging the location, a physical model of or an impression of the location, in relation to the system. The acquisition unit and the positioning

unit may be part of a 3D scanner. The acquisition unit may comprise one or more cameras adapted for acquiring both geometrical data and textural data

In some embodiments, the location is automatically repositioned relative to the acquisition unit during the acquisition of the 2D digital representation comprising textural data and during the acquisition of the 3D digital representation comprising geometrical data, such that at least one of the digital representations is acquired automatically from a number of different viewpoints and the desired coverage is obtained. Both the 2D digital representation and the 3D digital representation may be acquired automatically from a number of different viewpoints

In some embodiments, the positioning unit provides an automatic repositioning of the location relative to the acquisition unit.

Within dentistry, the dental technician may draw features directly on a physical model or an impression of the location, which drawn features may be denoted annotations, and where the features may be lines to be used for modeling of the object. The lines may for example be the preparation margin line for a tooth restoration, or the major connector, clasps and retention grids for a partial denture. Thus these drawn features, such as lines, may be used as the texture information.

When using direct scanning, such as intra oral scanning, the texture may be present on the teeth in the form of colors, shades, material properties etc. The feature may be a line drawn directly on the teeth or on the soft tissue of the patient's palette. For instance, when the 3D object comprises a removable partial, a preferred shape of the removable partial can be indicated on the teeth and soft tissue.

30

When using impression scanning the texture is present on the impression in the form of for example the fine-structure of the surface of the impression material. Within dentistry grinding a tooth or grinding a preparation line produces a more rough surface structure, where the grinding is made, and this rough structure is transferred to the impression material when making an impression of the teeth. The part of a tooth which is not grinded has a smoother surface than the rough surface of the grinding.

In some embodiments acquiring the 2D digital representation comprising textural data and the 3D digital representation comprising geometrical data of the location comprise acquiring 2D images and scanning, respectively, the location from a number of different viewpoints. Acquiring the 2D digital representation may comprise acquiring one or more 2D images of a physical model of the location or of an impression of the location, and/or by acquiring 2D images directly of the location. The 2D images may be acquired using one or more cameras.

An advantage of this is that when acquiring 2D images and scanning, respectively, the location from different viewpoints, then data for all or the relevant features of the location may be acquired. Different viewpoints may comprise different angles etc.

In some embodiments, the part of the 2D digital representation comprising textural data which is combined with the 3D digital representation comprises one or more sections of the 2D images of the acquired 2D digital representation. The one or more sections of the 2D images may be the sections that relates to the feature of the location.

In some embodiments the 3D modeling of the 3D object is performed automatically based on the one or more features.

An advantage of this embodiment is that the user does not need to perform any manual modeling of the 3D object on the user interface, when the

modeling can be performed fully automatic. If an automatic modeling takes place, then the user may check that the modeling is satisfying, and maybe perform small corrections to the modeling.

- 5 In some embodiments, the 3D modeling comprises defining one or more edges of the 3D object based on the information.

The method may comprise providing a 3D model of the 3D object, and the 3D modeling may comprise adapting the provided 3D model of the 3D object
10 based on the information. The provided 3D model may be provided from a library.

The adapting of the provided 3D model of the 3D object may comprise shaping the edges of the provided 3D model of the 3D object based on the
15 information. This may for example be realized using computer software which allows the user to identify the information, such as said 3D spline, as the edge of the 3D object.

The automatic modeling may comprise modeling the 3D object based on the
20 information extracted from the 2D digital representation comprising textural data of the location. The extracted information may relate to a boundary of the modeled 3D object, such as e.g. the perimeter of a restoration which is modeled to be positioned at a prepared tooth where the feature is the margin line of the prepared tooth. The extracted information may be in the form of a
25 2D spline following the feature on in a 2D image of the 2D digital representation or of a 3D spline following the feature on the 3D digital representation comprising geometrical data.

Once the edge of the 3D object is extracted from the 3D spline, the 3D object
30 may be defined using standard algorithms such as algorithms that can be implemented using computer software. The 3D object or at least parts of the

object may be formed using input from libraries, such as when a structure of a part is defined by input from a library and the perimeter of the part is defined by the 3D spline. This may e.g. be the case for the retention grid of a removable partial denture, where a holed structure of the surface may be provided from a library while the perimeter may be derived from a 3D spline.

In situations where the 3D object is an object used within dentistry, such as a restoration or a removable partial denture, the shape of the 3D object may partially be extracted from the 3D digital representation comprising geometrical data and partially from the 3D spline. That is the cusp or incisal edge and the labial, proximal and lingual surfaces of a tooth preparation can be extracted from the 3D digital representation comprising geometrical data while the surface of the restoration facing the margin line of the prepared tooth or abutment is extracted from the feature.

In some embodiments the 3D object is adapted to replace an anatomical object of the patient's body.

Thus the object may be an artificial hip for replacing a broken hip, or a respiratory device for replacing the respiratory tract or a part of it, or a breast prosthesis for replacing a breast which has been removed due to e.g. a malignant tumor. Thus the objects may be used as replacements if the original anatomical object is broken or attacked by a disease.

However, the object may also replace an anatomical object for pure cosmetic reasons, such as replacing or remodeling breasts, buttocks, lips, nose, face, stomach, thighs etc. using e.g. plastic surgery.

In some embodiments the 3D object is adapted to be inserted in a body cavity of the patient.

Examples of objects which are adapted to be inserted in a body cavity are hearing devices to be inserted in the ear canal, dental restorations, dental implants, orthodontic appliances etc. to be inserted in the mouth,

contraceptive devices, such as a diaphragm, to be inserted in a female vagina, a glass eye to be inserted in an empty eye socket etc.

In some embodiments the location is the mouth of the patient.

5

In some embodiments the location is one or more teeth of the patient.

The location may be a tooth preparation prepared for a restoration such as a crown or a bridge.

10

In some embodiments the location is an ear canal of the patient.

In some embodiments extracting information of one or more features of the location comprises feature detection.

15

An advantage of this embodiment is that feature detection comprises methods that compute abstractions of image information and perform local decisions of every image point, where the decisions concern whether there is a feature of a given type at that point or not. Thus the resulting feature may be subsets of the image domain, e.g. in the form of isolated points, continuous curves or connected regions.

20

In some embodiments the extraction of information of features is performed by detecting features which are present on the combined 3D digital representation and/or on the 3D digital representation comprising geometrical data.

25

An advantage of this embodiment is that features can be detected by comparing the textural data and the geometric data at each point of the location. For example both the geometrical data and the textural data may show a feature, e.g. curve, in the same place, and this may mean that the feature is both geometrical and textural, and it may also be a confirmation
30 that the feature is a real feature in the location, e.g. on the model or impression, and not just an error. If for example only the geometrical data

show a feature in that place, and then this means that there is no textural feature there, or only the textural data may show a feature in that place, and this means that the feature is not geometrical or spatial but only textural, e.g. visible color. The last may be the case, when the dental technician has drawn
5 some features on e.g. a model of the teeth for example for indicating where a removable partial denture should be arranged on the model and eventually in the mouth of the patient. Many dental technicians may prefer to work manually with a gypsum model, and when they draw the outline of e.g. a partial removable partial denture on the gypsum model, then the drawing is
10 detected or captured when performing the textural data acquisition.

In some embodiments feature detection comprises examining every pixel in one or more of the digital representations to detect if there is at least part of a feature present at that pixel.
15

In some embodiments the one or more features are selected from the group of lines, contours, curves, edges, ridges, corners, or points.

It is an advantage that the different features can be detected by means of a feature detector which may be a software algorithm. Feature detectors can
20 be classified into two different categories: intensity-based detectors and structure-based detectors. The intensity-based detectors analyze local differential geometry or intensity patterns to find points or regions that satisfy some uniqueness and stability criteria. The structure-based detectors analyze structural features such as lines, edges, and curves to define so-called interest points or regions.
25

Edges may be defined as points where there is a boundary or edge between two image regions, and edges can thus be defined as sets of points in the image which have a strong gradient magnitude. Some algorithms can link
30 high gradient points together to form a more complete description of an edge.

The algorithms may put constraints on the properties of an edge, such as shape, smoothness, and gradient value.

5 Corners are point-like features in an 2D image, which have a local 2D structure. After performing edge detection, the edges can be analyzed to detect rapid changes in direction, i.e. a corner.

10 Points or interest points are points which can be detected by searching for high levels of curvature in the image gradient. E.g. a dark spot or point on a white background can be detected by looking at the curvature in the image gradient.

15 Blobs or larger regions of interest points are areas in a 2D image which may be too smooth to be detected as a point, but these regions may still have a preferred or key point, such as a local maximum or a centre of gravity.

20 A ridge can be defined as a one-dimensional curve that represents an axis of symmetry and also has an attribute of local ridge width associated with each ridge point.

When a feature has been detected, the result may be a feature descriptor or feature vector which identifies a local region of the image.

25 When a feature has been detected, a local image patch around the feature can be extracted by means of image processing, and the result may be denoted a feature descriptor or feature vector.

Some common feature detectors are:

- 30 - for detecting edges: Canny and Sobel;
- for detecting interest points or corners: Harris, Shi & Thomasi, level curve curvature, and FAST;

- for detecting blobs or larger regions of interest points: Maximally stable extremal regions (MSER) and principal curvature-based region detector (PCBR). MSER is an example of an intensity-based detector.

5 In feature detection tasks changes in lighting, pose, color and texture can cause considerable variation in local intensities, and therefore local intensity may not provide a stable detection cue. Intensity-based detectors may therefore fail to identify discriminative features. An alternative to capturing
10 local intensity cues is to capture semi-local structural cues such as edges and curvilinear shapes. These structural cues may be more robust to intensity, color, and pose variations. The PCBR detector exploits these more reliable image structural cues.

The information of the one or more feature may comprise one or more 3D
15 splines that are extracted from the 2D digital representation comprising textural data using various techniques. The 3D spline may e.g. correspond to pencil markings on a physical model of the location, and the method may comprise extracting the 3D spline and applying it in the 3D modeling of the 3D object.

20 For some applications, such as when extracting information from pencil markings on a physical model, the presentation of the features in the 2D images of the acquired 2D digital representation may need to be improved by for example by enhancing the contrast or by removing of noise from the 2D
25 image. The features may be detected in the 2D images of the 2D digital representation and registered into the 3D digital representation comprising geometrical data.

In addition to the image processing and the feature detection, the method may comprise 3D spline detection, where the 3D spline detection comprises
30 merging two or more 2D splines to provide the 3D spline.

The image processing may comprise a filtering, such as a Coherence-Enhancing Diffusion Filtering, applied to remove sensor noise. In addition to sensor noise, the features may comprise segments that are not coherent and/or segments that are not ideally defined on the location. When e.g. drawing a line with a pencil on a physical model of the location, the pencil may jump over the surface of the physical model thus leaving gaps in the line, or the operator may have drawn a line consisting of partially overlapping segments. In the case of segmented line a gradient approach may be applied to determine whether to adjacent lines are oriented such that one segment is arranged such that it can be considered an extension of the other segment. In that case, the two line segments may be considered to be part of the same line.

The image processing may comprise a contrast enhancement in the 2D image, such that e.g. pencil markings on a physical model of the location appear more clearly in the 2D images of the 2D digital representation. The contrast enhancement may be provided by e.g. a modified Sigmoid function, where the amount of contrast enhancement is decided by a single parameter, the alpha parameter, going from 0 to 1, where alpha values approaching 0 gives a linear exchange (no effect) and an alpha value of 1 gives an even sigmoid function.

Image sharpening making the transition between markings and background more obvious may also improve the reliability of the extracted information of the one or more features.

After the image processing, the features may be isolated in the 2D images, such that they can be detected and the information can be extracted. An automatic Scale-space selection may be used for the detection of the features.

Depending on the broadness of e.g. a pencil stroke on a physical model of the location, the scale at which the markings are best identified can automatically be found. The Scale-space selection may also be part of the images processing.

- The detection of the features as ridges or edges in the 2D images of the 2D digital representation may provide a number of possible pixel candidates to be identified as the feature. These candidates need to be sorted and converted to splines. This may be done in a sequence comprising excluding
- 5 very small line pieces. Whether this exclusion is to take place may depend on the image quality. If the image quality and/or the definition of features are such that disjunct line pieces of the features cannot be closed or connected during preprocessing of the 2D images and/or the feature detection, it may be advantageous that the exclusion of small line pieces does not take place.
- 10 A rough sorting may be used to exclude candidates whose 3D position is on a facet with a very steep angle to the eye-ray of the camera used for acquiring the 2D image. This will exclude silhouette-edges as well as low quality data.
- Possible 3D splines corresponding to e.g. the pencil marking of a dental technician can then be identified using both geometrical data from the 3D
- 15 digital representation and the detected 2D ridges/edges in combination. In the identification of the 3D splines, certain rules may have to be set up in order to handle line crossings, corners, and blobs.
- 20 Image patches showing sections of the surface of the location can be found from the 2D images of the 2D digital representation comprising textural data. The image patches may be aligned such that patches relating to neighboring sections of the location are aligned side by side. Texture weaving may then be applied in order to ensure that any visible transitions appearing at the
- 25 borderline between neighboring image patches are made less visible. Such a visible transition could e.g. be a transition between a section imaged with a more intense illumination of the location and a section imaged with a less intense illumination of the location. The texture weaving may be made to smoothen visible transition between the different sections of the visualized
- 30 combined 3D digital representation in order to improve the appearance of the visualized 3D digital representation. During the extraction of information,

such transitions could also in some cases lead to a false identification of the transition as a feature of the location. The texture weaving may be performed by comparing pixel intensities within two neighboring patches and assigning intensity values to the pixels across the transition between two patches such
5 that a smooth change in the pixel intensity is obtained.

3D Splines may be optimized by an operator using control points on the 3D spline where the position of these control points relative to the location can be optimized using a pointer tool, such as a mouse, or data entry using e.g. a
10 keyboard.

The 3D modeling of the object may comprise defining a part of the object by the extracted 3D spline. The method may hence comprise automatically adapting the shape of that part to the 3D spline.
15

In some embodiments the one or more features comprises a margin line of a prepared tooth or die.

The margin line is the preparation margin line, which the dentist has grinded in the patient's tooth for preparing the tooth for a restoration e.g. a crown or
20 bridge. The dental technician may draw a physical line with a color pen on a physical gypsum model for marking the margin line of a prepared tooth.

The texture of the model or die or tooth where a preparation margin line has been grinded is more rough than the surrounding surface, which is smooth, such as enamel on tooth. A preparation line may be made using a dental tool
25 which is typically not less than 1 mm in diameter. So the preparation margin line can be detected by studying the texture of the model or die or tooth. Microtexture may also be detected. Burn marks from the grinding of the preparation line can also be detected in a texture scan.

Thus grinding marks of the margin line may be photographed or captured as
30 textural features using a regular light source and a camera, where the camera for example has a high resolution. However, a 3D scanner

comprising a light source and a camera for scanning geometrical features may also be used for scanning preparation margin lines as the geometrical features.

- 5 When detecting a preparation margin line in e.g. the geometrical data representation, the margin line may automatically be marked, e.g. as a clear red line, on the digital representation of the location.

10 In some embodiments the one or more features comprises the shades of the patient's teeth.

An advantage of this embodiment is that if for example the textural data of the features are acquired by performing a direct scanning of the patient's present or existing teeth, then the shade or color of the teeth can be captured as textural data and thus as textural features, and this information can be
15 used to model or apply the correct shade of the object for example a restoration, artificial teeth in a full or partial denture, an implant etc. This may be a very efficient and fast method for determining the correct shade of the object, which is particularly important for dental applications.

20 In some embodiments the one or more features are drawn on the location, on a physical model of the location, or on an impression of the location by a user prior to the acquisition of the 2D digital representation comprising textural data.

25 An advantage of this is that the dental technician can design the object manually by drawing or grinding or providing other textural markings on the physical model, if he or she prefers this.

30 In some embodiments, the features are part of the 3D object that is to be modeled. This may for example be different parts of a removable partial denture or of an orthodontic appliance which are arranged to form part of the location from which the digital representations are acquired. These parts may

then be identified in the combined 3D digital representation, and in the 3D modeling of the 3D object these parts may be modified or maintained depending on the preference of the operator.

5 The 3D object may comprise a removable partial denture such that the one or more features may be major connectors, clasps and/or retention grids, and such that the 3D modeling comprises defining one or more edges of the removable partial denture from the 3D feature.

In some embodiments the one or more features are used for modeling a
10 removable partial denture, and the one or more features are major connectors, clasps and/or retention grids.

An advantage of this is that a partial denture may be a complex object having several different components, and it may be faster and intuitively easier for the dental technician to first design and model this rather complex dental
15 device manually instead of on a graphical user interface.

In some embodiments the 3D object comprises orthodontic appliance or bracket, such that the one or more features are used for modeling such an orthodontic appliance or bracket, and the one or more features are bracket
20 position(s), screw position(s), metal framework, plastic shelves, shells, bite plates, push rods, and/or springs. The 3D modeling may comprise defining the bracket positions and/or the screw position from the 3D feature.

An advantage of this is that an orthodontic appliance may be a complex object having several different components, and it may be faster and
25 intuitively easier for the dental technician to first design and model this rather complex dental device manually instead of on a graphical user interface.

In some embodiments different features are drawn with different colors by the user.

30 An advantage of this is that the different features can easily be distinguished due to the different colors.

Furthermore, the colors used for drawing on the impression or model should be colors with contrast to the model or impression and to the background color in the compartment, e.g. in the scanner, where the impression or model is scanned, such that the drawing can actually be imaged or recorded. For
5 example brown drawings may not provide enough contrast to a dark model or a black background compartment. A definition of contrast is that it is the difference in visual properties that makes an item, or its representation in an image, distinguishable from other items and the background. Thus the item may be an impression or a physical model of teeth or the teeth themselves.
10 In visual perception of the real world, contrast is determined by the difference in the color and brightness of the item and other items within the same field of view.

In some embodiments the feature is a borderline between different structures
15 of the location.

In some embodiments the feature is a borderline between different materials of the location.

A borderline may also be denoted a transition, a relief, or a change in the height and/or material in the location.

20 A preparation margin line may be a borderline, since it is a transition between a grinded part, the rough preparation margin line, and a non-grinded part, the smooth enamel of the tooth.

Palate wrinkles may be a borderline, since the palate wrinkles are a kind of relief, where the surface changes in height. The detection of palate wrinkles
25 can be used to model e.g. a partial denture for a patient, which will be adjoining the palate.

The transition between papilla of the gums and teeth can be a borderline, since here different materials are present, the hard enamel of the teeth surface and the soft tissue of the gum or gingival.

The borderline may be part of the location and hence directly defined on the location. The borderline may also be defined on a physical model of the location or on an impression of the location

5 In some embodiments acquiring the 3D digital representation comprising geometrical data and acquiring the 2D digital representation comprising textural data are performed sequentially.

Thus the digital representations may be acquired in two separate recordings, using one recording means or two or more recording means, which may be
10 arranged either as separate devices or arranged as one device.

Alternatively the acquisition of the 3D digital representation comprising geometrical data and the acquisition of the 2D digital representation comprising textural data are performed simultaneously.

15 In some embodiments, at least one of the digital representations is acquired by illuminating at least part of the location, a physical model of the location, or an impression of the location with light, such that the 2D digital representation comprising textural data and/or the 3D digital representation comprising geometrical data may be acquired by illuminating the location with
20 light

In some embodiments the light used to acquire at least one of the digital representations is multispectral light comprising light at N wavelengths, wherein the number N is equal to or larger than 2.

25 In some embodiments, the method comprises using different colors or color codes to identify different features, where the different colors or color codes correspond to the N wavelengths of the multispectral light. Such that the color used to identify one feature reflects light at one wavelength, while the
30 color used to identify another feature reflects light at another wavelength.

Which kind of light illumination to be used when scanning is dependent on whether an impression or a model is scanned or whether direct scanning of the location, e.g. teeth is performed. If using a 3D scanner to scan an impression or a model, the compartment into which the impression or model is arranged for scanning it, could be e.g. black or white. If the compartment is colored white, the light for scanning may be reflected diffusively inside the compartment. The diffusively reflected light may be advantageous for imaging texture on the impression or model. However, if the compartment is colored black, then there may be no reflection of light. Thus for different scanning purposes, such as geometrical scanning or texture scanning, where color can be scanned or recorded, the color and the shape of the compartment of the scanner could advantageously be changeable, such as to be suitable for the different scanning or imaging modes.

A 3D scanning device configured for acquiring the 3D digital representation may be based on the projection of one or more sheets of light or another known pattern of light onto the location. The source of illumination may be a low-power laser in the visible light spectrum, or the illumination of the location for acquisition of geometrical data and/or textural data may be performed using a different kind of laser, a laser diode, or light emitting diodes, LEDs, emitting e.g. red, green, and blue light.

The sensor for receiving, measuring, and converting the reflected light or signal from the location may be a five megapixel camera with a resolution of 35 micrometer. There may be more than one camera for capturing the reflected light from the location, but the cameras may all capture both the geometrical data and the textural data of the location.

In some embodiments the N wavelengths in the multiprecpectral light used for the illumination of the location are provided in a sequence, such as a sequence comprising red, green and blue light. Each step in the sequence may be performed without any overlap or with an overlap with the preceding

and/or the following step in the sequence. In case of overlapping steps it may be required that the timing of the acquisition of 2D images of the 2D digital representation is such that the 2D images are acquired while light at only one wavelength illuminate the location. Overlapping steps may also be used in
5 relation to cases where color codes with two or more colors are used for the identification of different parts of the feature or different features.

Alternatively and/or additionally, other spectral peaks may also be employed, e.g. near infrared (NIR) or ultra violet (UV). Wave-length dependent calibration of the optical system may be performed in order to ensure spatial
10 correspondence of the recorded surface reflectivity measures.

Furthermore, color information may be acquired simultaneously through the use of multiple sensors and beam splitters, or through the use of color filter arrays (CFA), which may be arranged in a Bayer-type arrangement.

15 In some embodiments, N is 3 such that the multispectral light comprises light at a first wavelength, light at a second wavelength, and light at a third wavelength. When N equals 3, the sequence may be first wavelength, second wavelength, and third wavelength. The different permutations of this order is also possible, such that light at the second wavelength is followed by
20 light at the first wavelength which then is followed by light at the third wavelength.

The sequence may thus be first wavelength, third wavelength, and second wavelength.

25 The sequence may thus be second wavelength, first wavelength, and third wavelength.

The sequence may thus be second wavelength, third wavelength, and first wavelength.

30 The sequence may thus be third wavelength, second wavelength and first wavelength.

The sequence may thus be third wavelength, first wavelength, and second wavelength.

5 The first, second and third wavelengths may be in the red, green, and blue range of wavelengths, respectively.

In some embodiments, the N wavelengths in the multispectral light are provided simultaneously.

10 In some embodiments, the N wavelengths in the multispectral light are provided in a white light source, such that the location is illuminated with the N wavelengths and any other wavelengths of the white light source.

The white light source may comprise white diodes emitting light over a significant part of the visible part of the electromagnetic spectrum.

15

A 2D image may be acquired for each of said N wavelengths.

In some embodiments an 2D image is acquired for each of said N wavelengths, such as for each of red, green and blue light.

20 Acquiring data relating to features, e.g. lines, such that they appear or are present in the resulting 2D or 3D representation, may be possible using regular light illumination and e.g. acquiring a black/white representation. But in order for capturing the correct color of the lines, e.g. if they are drawn on the impression or model using a pen, the colors can be acquired using
25 sequential illumination, where the red, the green and the blue light from e.g. light diodes are detected separately.

In some embodiments the 2D images acquired for the each of the N wavelengths in the multispectral light, such as for the red, green and blue
30 light, are stitched together into a common 2D image. The 2D digital representation may comprises one or more common 2D images, each

common 2D image comprising 2D images acquired at each of the N wavelengths

5 In the context of the present invention, the phrase "blue light" and "light with a wavelength in the blue range" may be used in relation to electromagnetic waves propagating with a wavelength in the range of about 450 nm to about 490 nm.

10 In the context of the present invention, the phrase "green light" and "light with a wavelength in the green range" may be used in relation to electromagnetic waves propagating with a wavelength in the range of about 490 nm to about 560 nm.

15 In the context of the present invention, the phrase "red light" and "light with a wavelength in the red range" may be used in relation to electromagnetic waves propagating with a wavelength in the range of about 635 nm to about 700 nm.

20 In some embodiments the method comprises texture weaving, which comprises weaving the one or more features together between neighbor 2D images based on the textural data of the 2D digital representation.

25 An advantage of this embodiments is that the texture such as color in the resulting 2D image appears to be natural and correct, and surface scattering from e.g. skin is accounted for. The object of texture weaving and similar processes are to filter out all changes in appearance that are due viewpoint or light properties, i.e. modulations of the surface that are a result of external processes, rather than inherent properties of the object surface. Texture weaving smoothes out transitions between different images, such that the transitions becomes smooth with regard to texture, such as different features, e.g. color etc. Thus in order to capture textural data for the entire
30 location, a number of 2D images may be acquired and weaved together, e.g. four textural images may be captured for covering the entire location. Image

processing may be used to remove specular effects from the surface of the location for which data are being captured.

Scans of the location acquired from different viewpoints relative to the location using e.g a laser as the first light source may be stitched together,
5 and several geometrical scans may be acquired for covering the entire location, and thus the geometrical features may be stitched together.

Texture weaving is sometimes also referred to a texture blending.

Texture weaving is described e.g. in Marco Callieri, Paolo Cignoni, Claudio Rocchini, Roberto Scopigno: Weaver, an automatic texture builder from
10 Proceedings of the First International Symposium on 3D Data Processing Visualization and Transmission (3DPVT'02), 2002, IEEE Computer Society.

In some embodiments the method comprises laser modulation of the light used for acquiring the 3D digital representation comprising geometrical data.

15 An advantage of this embodiment is that laser modulation can help with acquiring geometry on surfaces with non-uniform reflectivity, thus the laser source may be modulated during acquisition of geometrical information in order to compensate for variations in reflectivity, both in a diffuse and in a specular setting. This will, in turn, allow for geometry acquisition of the
20 objects exhibiting a dynamic range greater than that of the camera sensor.

The same approach can be employed for texture acquisition, however here there may be an added requirement of detailed knowledge regarding the amount of emitted light.

25 Laser modulation may be performed using a modulator which is a device which is used to modulate a beam of light, where the beam may be carried over free space, or propagated through an optical waveguide. The modulator may manipulate different parameters of the light beam, such as amplitude, phase, polarization etc. Modulation of intensity of a light beam can be obtained by modulating the current driving the light source, e.g. a laser diode.

30

In some embodiments, the method comprises modulation of the light used for acquiring the 2D digital representation comprising textural data.

5 In some embodiments acquiring the 3D digital representation comprising geometrical data of the location and the 2D digital representation comprising textural data of the location is performed by means of a scanner adapted for capturing geometrical data and textural data.

10 In some embodiments acquiring the geometrical data and the textural data is performed by means of a camera adapted for capturing both geometrical data and textural data.

The camera may be a five megapixel color camera.

15 Alternatively, two or more cameras may be provided which have different resolutions to capture data for different kinds of features or for different geometrical or textural features.

In some embodiments acquiring the geometrical data is performed by means of a first light source, and acquiring the textural data is performed by means of a second light source.

20 The second light source may comprise an array of diodes, where the array of diodes comprises a number of first diodes, a number of second diodes and a number of third diodes, where the first, second diodes and third diodes are adapted to emit light at a first, second and third wavelength, respectively.

25 The second light source may comprise a diffuser arranged to provide a diffusion of the emitted light, such as a diffusion of the light emitted from a white light source or from an array of red, green and blue diodes.

30 The geometrical data may be captured using a laser, where a number of scans captured from different angles may be stitched together into an assembled model. Furthermore, the 2D digital representation comprising

textural data may be acquired using a regular white light source, and the result may be a 2D image. A few 2D images may be suitable for covering the entire location, and textural weaving may be performed to avoid incoherent or bad transitions between the 2D images.

5 Alternatively, the same light source may be used for capturing both the geometrical data and textural data. An advantage of using only one light source, is that geometrical data and textural data can be captured simultaneously, whereas when using two light sources, the light sources may not be turned on at the same time, since one of the light sources may disturb
10 the capturing of data using the other light source.

Alternatively and/or additionally, color filters can be employed allowing for simultaneous acquisition of geometry and texture data.

Alternatively and/or additionally, light may be provided at the acquisition unit, e.g. a ring of light around the receiving optics of the camera(s). An advantage
15 of this is that the light/camera angle can be minimized and thereby the amount of deep shadows in deep cavities can be minimized.

The light source may be white light, such as structured white light or white light in combination with a grid.

20 In some embodiments, the positioning unit comprises at least a two-axis motion system, such that the positioning of the location during the acquisition of the 3D digital representation comprising geometrical data and the 2D digital representation comprising textural data is performed automatically by
25 means of the at least a two-axis motion system.

In some embodiments, the method comprises that the acquisition of geometrical data and textural data is performed automatically by means of at least a two-axis motion system.

It may be an advantage that the acquisition and the motion system runs
30 automatically, such that no operator should manually select each position. The motion system may be e.g. a two-axis or three-axis motion system, since

hereby data of the location can e.g. be captured both from the sides and from above.

In some embodiments the method comprises providing a 3D face scan of the patient for facilitating visualizing the result of the modeling of the 3D object.
5 It may be an advantage to use a 3D face scan of the patient when modeling e.g. restorations, a partial denture, orthodontic appliances etc., because the modeled object can then be seen or viewed in connection with the patient's entire face and look.

10 In some embodiments the 3D digital representation comprising geometrical data of the location, and/or the 2D digital representation comprising textural data of the location is/are obtained by means of a 3D face scan.

15 In some embodiments the method is adapted to be used for 3D modeling within dentistry.

In some embodiments dentistry comprises restorations, implants, orthodontics, such as bracket placement and appliances, and partial
20 dentures, such as removable partial dentures.

Within restorations it is an advantage that the preparation margin line can be detected from the representation of geometrical data and textural data.

25 Within orthodontics it is an advantage that the dental technician can draw on a physical model where the appliance or brackets should be arranged, or that tooth segmentation can automatically be performed using the representations of geometrical data and textural data.

In the modeling of a 3D object used within dentistry, an edge of the one or
30 more parts of the 3D object may be defined by the extracted information, such as the 3D spline.

The 3D modeling may comprise extracting a plurality of features, such as a plurality of lines drawn on a physical model of the location, where a number of features relate to one part of the 3D object. For example, when modeling a removable partial denture, the retention grid may be defined by a number of drawn lines on a physical model of the teeth and palette. When a number of features are detected, they may be mapped to specific parts of the 3D object based on knowledge specific parts and/or based on the the location, length, color, and shape of the feature. The different parts of a removable partial denture, such as the retention grid, the window, the major connector and the minor connectors may for example be defined using different colors. They may also be identified from the knowledge that the window is at the palette and that the retention grid is on the gingival. When the modeled 3D object is a removable partial denture, the 3D feature may be a 3D spline defining the perimeter of a part of the removable partial denture, such as e.g. the retention grid or the major connector.

The different parts of a 3D object may also be defined using identification marks, such as two or more concentrically arranged circles, crosses, squares, triangles, and so forth. The number of elements in the identification mark may also be used, such that e.g. the retention grid of a removable partial denture has one mark, the major connector has two, and so forth.

In some embodiments, the feature comprises identification marks arranged within a substantially closed edge of the feature. The closed edge may for example be a closed loop drawn on a physical model of the location. The identification marks may be selected from the group of concentrically arranged circles, crosses, squares, triangles, the number of elements in the identification mark, such as the number of dots.

A closed loop may for example be drawn to mark the edge of different parts of a removable partial denture and different identification marks may be used

to identify these different parts. The major connector may for example be identified using one dot, the retention grid using two dots and a window using three dots.

- 5 Furthermore, the method can for example be used for determining occlusion of a patient by placing a color trace paper between the patient's upper and lower teeth, and when the patient bites his teeth together, the paper will transmit color to the colliding points on the teeth, and this transmitted color can be captured as textural data. Determining occlusion may be performed
10 either directly in the mouth and thus on the real teeth of the patient, or it may be performed on a physical model of the teeth, e.g. gypsum model, using e.g. an articulator.

In some embodiments the method is adapted to be used for 3D modeling of
15 hearing devices. The feature may then define the boundary of an inner face or an outer face of the hearing aid device, the position or cross sectional shape of the vent, or an ID-tag for the hearing aid device.

The feature may be defined on a physical model or an impression of the ear canal in relation to which the hearing aid device is adapted to be arranged.

- 20 The hearing aid device may be an in-the-ear device, an in-the-canal device, or a behind-the-ear device. The feature may relate to different parts of the hearing aid device, such as to the shell, an ear mould or an integrated face plate of the device.

- 25 In some embodiments, the information is extracted by an operator from the visualized combined 3D representation comprising both geometrical data and textural data. The operator may for example identify different pieces of information as relating to the same feature. This may e.g. be done while visualizing the combined model on a graphic display.

30

The method can also be used for modeling of customized shoes with a perfect fit for the patient, where the geometrical and textural features of the patient's feet are acquired either by direct scanning or by making an impression of the feet and then scanning the impression or producing a physical model from the impression and then scanning the physical model.
5 The textural data of the feet are also acquired.

In some embodiments, the method is implemented on a computer program product comprising program code means for causing a data processing
10 system to perform the method of any one of the preceding claims, when said program code means are executed on the data processing system.

The first and/or the second digital signal processor unit may be configured for extracting the information of the one or more features from the 2D digital
15 representation.

The first and the second digital processor units may be integrated parts of a digital signal processing device, such that the digital signal processing device is configured for analyzing and combining the acquired digital representations
20 and for modeling the 3D object.

The acquisition unit may comprise:

- means for acquiring a 3D digital representation of at least a part of a location arranged in said scan volume, where the 3D digital representation
25 comprises geometrical data of the location; and
- means for acquiring a 2D digital representation of at least a part of location arranged in said scan volume, where the 2D digital representation comprises textural data of the location;

30 The acquisition unit may comprise a first set of cameras arranged arranged to receive light from the scan volume and to acquire both said 3D digital

representation comprising geometrical data and said 2D digital representation comprising textural data from a location. The first set of cameras is then part of both the means for acquiring a 3D digital representation and the means for acquiring a 2D digital representation. The first set of cameras may comprise two cameras arranged relative to the scan volume and the first light source such that a 3D scan of a location positioned in the scan volume is possible.

The system may comprise one or more further cameras in addition to the first set of cameras, such as a second camera or a second set of cameras.

In some embodiments, the acquisition unit is configured for acquiring textural data for N different features of a location, where each feature has a unique color or color code, and for distinguishing between said N different features based on said color or color code. The features may be defined using e.g. different colored inks or paints.

Likewise, the the acquisition unit may be configured for acquiring textural data for N different parts of a feature of a location, where each part has a unique color or color code, and for distinguishing between said N different parts based on said color or color code. In the following the description often focused on the acquisition of data relating to different features, but the comments made may apply equally to the case where data for different parts of a feature is acquired.

In some embodiments, the illumination unit of the system comprises a first light source adapted for providing light for the acquisition of geometrical data of a location, and a second light source adapted for providing light for the acquisition of textural data.

The light used for illuminating the location may hence comprise both light emitted from the first light source and the second light source.

The location may be illuminated simultaneously with the first and second light sources, or one at a time.

5 A light source which is adapted for providing light for the acquisition of geometrical data of a location may be configured for emitting light in substantially parallel rays.

A light source adapted for providing light for the acquisition of the acquisition of textural data may be configured to provide a diffusive light where the directions of different rays of light are more randomly distributed.

10 The first and second light sources may be arranged such that the optical axis of the first light source and the optical axis of the second light source intersects in a scan volume.

15 In some embodiments, the first light source comprises a monochromatic laser emitting light at a first laser wavelength. The light from such a monochromatic laser may be propagating in substantially parallel rays allowing for a precise determination of the geometry of a location.

20 The first laser wavelength may be in the green range of wavelengths, in the red range of wavelengths, or in the blue range of wavelengths. A red laser may, at the present time, provide a cost effective system as such lasers often can be purchased at a lower price than e.g. a blue laser. A green laser may have the advantage of providing a better spatial resolution when color cameras are used for acquiring the digital representations.

25 The second light source may be arranged at a different angle relative to the scan volume than the first light source but still such that light from the second light source can be reflected from a location in the scan volume towards cameras of the acquisition unit.

30

In some embodiments, the second light source comprises a broad band light source, such as a white light source, delivering light over a range of wavelengths. The second light source may be configured for providing light at all wavelengths of the colors or color codes used to defined features in a multicolor arrangement.

For some applications relating to the acquisition of textural data it may be preferred that the light is diffusive. The second light source may be adapted for providing diffusive light.

The second light source may be configured for providing light at isolated wavelengths such that a spectrum of the intensity distribution of the emitted light signal versus wavelength comprises a number of peaks.

The second light source may be realized using a design comprising a number of sources each emitting light at a single wavelength or in a relatively narrow wavelength range, where the signals emitted from each of these sources is combined to provide the light emitted from the second light source. The second light source may be realized using a design utilizing a resonant effect such as a Fabry Perot resonator.

In some embodiments, the second light source comprises an array of diodes, where the array of diodes comprises a number of first diodes, a number of second diodes and a number of third diodes, where the first, second diodes and third diodes are adapted to emit light at a first, second and third diode wavelength, respectively.

In some embodiments, the second light source comprises a diffuser arranged to provide a diffusion of the emitted light, such as the light emitted from a white light source or an array of diodes. Such diffusive light delivered from

the second light source may be adequate for acquiring information relating to the texture of the location.

In some embodiments, each camera in the first set of cameras comprises a
5 color camera comprising a color filter array (CFA) arranged in a Bayer-type arrangement, a so-called Bayer filter, in front of a photosensitive element configured to detect electromagnetic signals.

When using a Bayer filter it may be advantageous that the first light source emits light at wavelengths in the green passband of the Bayer filter, since the
10 Bayer filter provides that the spatial resolution provided by the camera is twice the resolution obtained using a first light source which emits light at a wavelength corresponding to red or blue light.

In some embodiments are one or more cameras in the first set of cameras a
15 monochrome camera. Each of the cameras may be monochrome cameras.

In some embodiments, the system comprises a scan plate located such that a location arranged on said scan plate is positioned in said scan volume, such that that light from both the first and second light sources can be
20 reflected from a physical model at the scan plate towards the acquisition unit of the system. The arrangement of the scan plate may hence be such that a least part of physical model or an impression placed on the scan plate is located in the scan volume of the system

25 In some embodiments, the control unit is adapted to control the motion and rotation of this scan plate..

In some embodiments, the system comprises a positioning unit for at least two-axis motion of the scan plate such that acquisition of the 3D digital
30 representation comprising geometrical data and of the 2D digital

representation comprising textural data from a number of positions can be performed automatically.

5 In some embodiments, the system comprises a positioning unit configured for arranging the location in a number of different positions relative to the acquisition unit, such that a desired coverage of the location can be obtained by acquiring the 2D digital representation comprising textural data and the 3D digital representation comprising geometrical data from the number of different positions.

10

In some embodiments, the system comprises a control unit configured for controlling the array of diodes and the positioning unit.

15 The control unit may be configured to provide that the first, second and third diodes emit light sequentially, such that a sequence of light signals are emitted. The sequence may be first wavelength, second wavelength, and third wavelength.

20 The control unit may be configured to provide that the sequence is repeated a number of times, such as one time for each relative arrangement of the optical assembly of the system and the scan plate.

25 In the context of the present invention, the phrase "optical assembly" may refer to the assembly of units used for providing the illumination of the location and for acquiring the 2D and 3D digital representations of the location. The optical assembly may comprise the acquisition unit and the light sources of the system.

30 In some embodiments, the second light source is designed such that the first, second and third diodes are arranged in accordance with a Bayer arrangement.

In some embodiments, a digital signal processor of the system is configured for real-time analysis of the acquired 2D digital representations and 3D digital representations.

- 5 The first set of cameras may be used to acquire both the 2D digital representation and the 3D digital representation. When placing a Bayer filter in front of the photosensitive elements of the cameras, it may be advantageous to use a laser emitting light in the green wavelength range as the first light source since this may provide a higher spatial resolution
10 compared to a red laser due to the design of a Bayer filter, where twice as many sections allows green light to pass through the filter as there are sections allowing red light to pass through.

A scanning of a physical model or an impression of a location can then
15 required in order to ensure that the acquired representations provides data for the whole feature. This may for instance be the case when the feature is a margin line on a physical model of a tooth prepared for a crown.

In some embodiments, the system comprises a motion system for at least two-axis motion such that acquisition of the 3D digital representation
20 comprising geometrical data and of the 2D digital representation comprising textural data from a number of positions can be performed automatically.

In some embodiments, the system comprises a control unit configured for
controlling the array of diodes and the motion system.

25 The control unit may be configured to provide that the first, second and third diodes emits light sequentially, such that a sequence of light signals are emitted. The sequence may be such the wavelength of the emitted light from the second light source is first wavelength, second wavelength, and third
30 wavelength. Any sequence of wavelengths can in principle be used depending on the purpose of the sequential illumination to the light of the

second light source. Preferably, the used sequence must be known by the digital signal processor or microprocessor which links each 2D digital representations to the wavelength(s) used when acquiring each of them.

- 5 The control unit may be configured to provide that the sequence is repeated a number of times, such as at least one time for each relative arrangement of the optical assembly and the scan plate.

10 The first, second and third diodes are arranged according to a Bayer arrangement, with alternating red and green diodes in a number of rows that are separated by rows having alternating green and blue diodes.

15 The used of a broadband light source, such as a white light source, or an light source configured for emitting light at a number of discrete wavelengths, such as an array of diodes may be advantageous when the different colors define the feature of the location.

20 The feature may e.g. comprise a section having a color which differs from the color of a different section of the feature and from the color of the surrounding regions of the physical model of the location. Such a section having a color may e.g. be a colored line drawn on
on a physical model of the location. A colored section reflects light over a limited range of wavelengths. Outside this limited range the reflection may be negligible such that when the colored section is illuminated with light having
25 wavelengths outside this limited range it will appear dark compared to when illuminated with light inside the range.

30 If the second light source comprises diodes that are driven to sequentially emit light at different wavelengths and the first set of cameras comprises black and white cameras, different 2D digital representations comprising textural data may be acquired by the black and white cameras, where each

2D digital representation comprising textural data is acquired at one color of the light emitted from the second light source.

5 The acquisition of 2D digital representations using light at different wavelengths makes it possible to define different types of features or different parts of features using different colors on the location or on e.g. a physical model of the location. The feature may comprise a colored line defined on a physical model of the location, such as a line having a color which allows the feature to be identified from the remaining part of the physical model.

10

Consequently if a feature is identified on the physical model using the three different colors, such that each color corresponds to the different parts of the feature, the different parts of the feature can be identified from the three different 2D digital representations that can be acquired using different colors from the second light source.

15

Different features can in the same manner be identified from different 2D digital representations comprising textural data if each feature is identified using a feature specific color e.g. on a physical model of the location.

20

In some embodiments, the system comprises a digital signal processor or microprocessor configured for real-time analysis of the acquired 2D digital representations and 3D digital representations.

25 The different part of the optical system can also be integrated in a handheld scanner, where the change between different relative arrangements of the system and the location (or a model or impression of the location) is obtained by moving the handheld scanner. The integration in a handheld scanner may require that some of the components of the system are reduced in size. In a handheld scanner system the digital signal processor or microprocessor may be placed in the scanner handle or in a separate processing box.

30

Some embodiments of the optical assembly of the system may utilize tunable filters that may be controlled by the control unit such that the tunable filters are synchronized with the acquisition of the 2D digital representations. The first set of cameras may then be monochrome cameras and the pass band of the tunable filters is changed such that 2D digital representations are acquired for a number of different pass bands. One pass band may cover part of the range of wavelengths corresponding to red light, while another may correspond to green light, and yet another to blue light. When tunable filters are used, the second light source may be a broadband source emitting a light over a range of wavelengths covering all pass band ranges of the tunable filter, or at least cover the colors used for defining the features e.g. on a physical model of the location.

The present invention relates to different aspects including the method described above and in the following, and corresponding methods, devices, systems, uses and/or product means, each yielding one or more of the benefits and advantages described in connection with the first mentioned aspect, and each having one or more embodiments corresponding to the embodiments described in connection with the first mentioned aspect and/or disclosed in the appended claims.

In particular, disclosed herein is a system for performing 3D modeling of a 3D object adapted to be inserted in or worn by a patient, wherein the system comprises:

- means for acquiring a 3D digital representation of at least a part of the location where the object is adapted to be arranged, where the 3D digital representation comprises geometrical data of the location;
 - means for acquiring a 2D digital representation of at least a part of the location where the object is adapted to be arranged, where the 2D digital representation comprises textural data of the location;
- where the acquisition of the 2D digital representation comprising textural data and 3D digital representation comprising geometrical data is performed by

repositioning the location and acquisition means relative to each other for obtaining a desired coverage of the location;

- means for aligning and combining the 2D digital representation comprising textural data and the 3D digital representation comprising geometrical data to
5 obtain a combined 3D digital representation comprising both geometrical data and textural data of the location;

- means for visualizing the combined 3D representation comprising the geometrical data and the textural data of the location; and

- means for applying information of one or more features from the 2D digital
10 representation comprising textural data of the location, when modeling the 3D object.

The acquisition of the 2D digital representation comprising textural data and
3D digital representation comprising geometrical data may be performed by
15 automatically repositioning the location and acquisition means relative to each other for obtaining the desired coverage of the location.

The means for acquiring a 3D digital representation may comprise an
acquisition device configured for acquiring a 3D digital representation of a
20 location.

The means for acquiring a 2D digital representation may comprise an
acquisition device configured for acquiring a 2D digital representation of a
location.

25 The means for aligning and combining the 2D digital representation comprising textural data and the 3D digital representation may comprise a data processing device configured for aligning and combining a 2D digital representation and a 3D digital representation.

30

The means for visualizing the combined 3D representation may comprise a visualization device configured for visualizing a 3D representation, such as a graphical user interface, such as a computer screen.

- 5 The means for applying information of one or more features from the 2D digital representation may comprise a device configured for applying information when modelling the 3D object.

10 The system may be configured for providing that the 3D modeling is computer implemented.

In some embodiments, the acquisition unit, the positioning unit, and the first and second light sources, are provided in a 3D scanner.

- 15 The first and/or the second digital signal processor unit may be configured for extracting the information of the one or more features from the 2D digital representation.

In some embodiments, the first and second digital processor units are integrated parts of a digital signal processing device. The digital signal
20 processing device may hence perform both the analysis and the 3D modeling of the 3D object.

In some embodiments, the acquisition unit comprises:

- means for acquiring a 3D digital representation of at least a part of a
25 location arranged in said scan volume, where the 3D digital representation comprises geometrical data of the location; and
- means for acquiring a 2D digital representation of at least a part of a location arranged in said scan volume, where the 2D digital representation comprises textural data of the location.

30

In some embodiments, the acquisition unit comprises a first set of cameras arranged arranged to receive light from the scan volume and to acquire both said 3D digital representation comprising geometrical data and said 2D digital representation comprising textural data from a location.

5

In some embodiments, the illumination unit comprises a first light source adapted for providing light for the acquisition of geometrical data of a location, and a second light source adapted for providing light for the acquisition of textural data.

10

The optical axis of the first light source and the optical axis of the second light source may intersect in the scan volume.

In the context of the present invention, the phrase "optical axis" may refer to an imaginary line that defines the path along which light propagates through the system. The optical axis of the first light source may hence be a line
15 connecting the first light source and a point on the scan plate of the system, where the point is in the volume which is illuminated by the first light source.

In some embodiments, the first light source comprises a monochromatic
20 laser emitting light at a first laser wavelength.

The first laser wavelength may be in the green range of wavelengths, in the red range of wavelengths, or in the blue range of wavelengths, or in the infrared range of wavelengths, or in the ultraviolet range of wavelengths.

25 In some embodiments, the second light source comprises a broadband light source, such as a white light source.

The acquisition unit may be configured for acquiring textural data for N
30 different features of a location, where each feature has a unique color or color code, and for distinguishing between said N different features based on said color or color code. The color or color codes may be defined using colored

ink or paint, or the color or color codes may be naturally occurring on the location.

5 In some embodiments, the second light source is configured for emitting light that allows features having a unique color or color code to be identified from an acquired 2D digital representation based on the wavelength of the light emitted from the second light source.

10 The second light source may comprise an array of diodes, where the array of diodes comprises a number of first diodes, a number of second diodes and a number of third diodes, where the first, second diodes and third diodes are adapted to emit light at a first, second and third diode wavelength, respectively.

15 In some embodiments, the second light source comprises a diffuser arranged to provide a diffusion of the emitted light.

The use of diffusive light for the acquisition of the 2D digital representation may provide that the textural data of the 2D digital representation are more detailed than when using a beam of parallel rays.

20

At least one of the cameras in the first set of cameras, such as both cameras in the first set of cameras, may comprise a color camera comprising a color filter array (CFA) arranged in a Bayer-type arrangement in front of a photosensitive element configured to detect electromagnetic signals

25

At least one of the cameras in the first set of cameras is a monochrome camera. Each camera in the first set of cameras may be a monochrome camera

30 In some embodiments, the system comprises a scan plate arranged such that a location arranged on said scan plate is positioned in said scan volume.

The scan plate may be part of the 3D scanner.

In some embodiments, the system comprises a positioning unit configured for positioning the location in a number of different positions and/or orientations
5 relative to the acquisition unit, such that a desired coverage of the location can be obtained by acquiring the 2D digital representation comprising textural data and the 3D digital representation comprising geometrical data with the location arranged at different positions and/or orientations relative to the acquisition unit.

10

The positioning unit may be configured for at least two-axis motion of the scan plate such that acquisition of the 3D digital representation comprising geometrical data and of the 2D digital representation comprising textural data from a number of viewpoints can be performed automatically.

15

In some embodiments, the system comprises a control unit configured for controlling the array of diodes and the positioning unit.

The control unit may be configured to provide that the first, second and third diodes emits light sequentially, such that a sequence of light signals are
20 emitted. The sequence may be first wavelength, second wavelength, and third wavelength, or any of said permutations.

The control unit may be configured to provide that the sequence is repeated a number of times, such as one time for each relative arrangement of the
25 optical assembly of the system and the scan plate.

The first, second and third diodes of the second light source may be arranged according to a Bayer arrangement.

The first digital signal processor and the digital signal processing device may be configured for real-time analysis of the acquired 2D digital representations and 3D digital representations.

5

Disclosed is system for performing 3D modeling of a 3D object adapted to be inserted in or worn by a patient, wherein the system comprises:

- means for acquiring a 3D digital representation of at least a part of the location where the 3D object is adapted to be arranged, where the 3D digital representation comprises geometrical data of the location;
- 10 - means for acquiring a 2D digital representation of at least a part of the location where the object is adapted to be arranged, where the 2D digital representation comprises textural data relating to one or more features of the location;
- 15 where a desired coverage of the location is obtained by acquiring each of the 2D digital representation comprising textural data and the 3D digital representation comprising geometrical data from a number of different viewpoints relative to the location;
- means for aligning the 2D digital representation comprising textural data and the 3D digital representation comprising geometrical data;
- 20 - means for combining at least a part of the 2D digital representation comprising textural data and the 3D digital representation comprising geometrical data to obtain a combined 3D digital representation comprising both geometrical data and textural data of the location;
- 25 - means for visualizing the combined 3D representation comprising the geometrical data and the textural data of the location; and
- means for 3D modeling the 3D object such that the modeled 3D object is adapted to be inserted in or worn by a patient, where said 3D modeling applies information of the one or more features from the acquired 2D digital representation comprising textural data.
- 30

Disclosed is also a computer program product comprising program code means for causing a data processing system to perform the method, when said program code means are executed on the data processing system, and a computer program product comprising a computer-readable medium
5 having stored there on the program code means.

Disclosed is also a system wherein fluorescence is used for acquisition of a 2D digital representation comprising textural data.

10 Fluorescence effects may also be utilized when the feature comprises a fluorescent material. The feature may e.g. be defined using fluorescent ink on a physical model of the location.

A feature comprising a fluorescent material having an excitation band including the wavelength of the first light source may provide a Stoke shift of
15 the wavelength of the first light source. In contrast, the light reflected from the location maintains its wavelength. Using various optical configurations known to the skilled person it is then possible to extract both the geometrical data and the texture data using only the first light source to illuminate the location. Since the fluorescence typically is orders of magnitudes weaker than the
20 reflected light it may be advantageous to detect the reflected light using the first set of cameras, while the fluorescence signal is detected using a second set of cameras. The second set of cameras may comprise a filter arranged to block light within the wavelength of the first light source, or filters may be placed between the location and the second set of cameras. The
25 fluorescence may also be detected using a single second cameras, i.e. such that the second set of cameras contains only one camera. In one embodiment, the feature is defined using a paint or ink comprising a fluorescent material configured for two-photon excitation and the first light source emits light at a wavelegth in the infra red range, such that when two
30 infra red photons are absorbed, a photon in the visible range is emitted. The 3D representation comprising geometrical data is then acquired by detecting

reflected infra red photons from the location, while the textural data directly can be acquired and related to the geometrical data.

5 **Brief description of the drawings**

The above and/or additional objects, features and advantages of the present invention, will be further elucidated by the following illustrative and non-limiting detailed description of embodiments of the present invention, with
10 reference to the appended drawings, wherein:

Fig. 1 shows an example of a flowchart of the method.

Fig. 2 shows examples of a model of teeth with textural features.

15

Fig. 3 shows an example of 3D modeling of a removable partial denture.

Fig. 4 shows an example of a modeled removable partial denture.

20 Fig. 5 shows examples of a preparation margin line as a feature.

Fig. 6 shows an example of texture weaving.

Fig. 7 shows an example of a setup for scanning a location using a first and a
25 second light source

Figs. 8 to 10 show schematic overviews of some configurations of the second light source that are capable of emitting light with its intensity distributed over a range of wavelengths

30

Fig. 11 show pictures of the optical assembly of a system according to the present invention.

5 Fig. 12 shows examples of arrangements of the array of diodes in the second light source.

Fig. 13 shows a schematic of a system using two-photon fluorescence for acquiring a combined 3D digital representation comprising both geometrical data and textural data.

10

Fig. 14 shows contrast enhancement for 2D images of a physical model of a tooth preparation.

15 Fig. 15 shows a texture atlas for a physical model of a tooth preparation.

Figs. 16 and 17 show screen shots from computer software used for implementing the method according to the present invention.

20 In the following description, reference is made to the accompanying figures, which show by way of illustration how the invention may be practiced.

Fig. 1 shows an example of a flowchart of the method. The method is for 3D modeling of an object, which is adapted to be inserted in or worn by a patient.

25 In step 101 a 3D digital representation of at least a part of the location where the object is adapted to be arranged is acquired, where the 3D digital representation comprises geometrical data of the location.

In step 102 a 2D digital representation of at least a part of the location where the object is adapted to be arranged is acquired, where the 2D digital representation comprises textural data relating to one or more features of the
30 location.

A desired coverage of the location is obtained by acquiring each of the 2D digital representation comprising textural data and the 3D digital representation comprising geometrical data from one or more different viewpoints relative to the location. Repositioning of the location relative to the system which is used for acquiring the digital representations may be performed manually or automatically;

In step 103, the 2D digital representation comprising textural data and the 3D digital representation comprising geometrical data are aligned.

In step 104 at least a part of the 2D digital representation comprising textural data and the 3D digital representation comprising geometrical data are combined to obtain a combined 3D digital representation comprising both geometrical data and textural data of the location.

In step 105, the 2D digital representation comprising the geometrical data and the textural data of the location is visualized. The digital representations may be shown on a graphical user interface, such as a computer screen.

In step 106 the 3D object is 3D modeled such that the modeled 3D object is adapted to be inserted in or worn by a patient, where said 3D modeling applies information of the one or more features provided by the acquired 2D digital representation comprising textural data.

The aligning, the combining, the visualization, and the application of information of the one or more features from the 2D representation for modeling may be digital, virtual actions, performed by means of software.

Fig. 2 shows examples of a model of teeth with textural features.

Fig. 2a) shows the model 201 which comprises teeth 202, gingival 203, and the palate 204 of a patient's mouth. The model 201 may be a physical model or a virtual model.

Fig. 2b) shows the model 201 with teeth 202, gingival 203, and the palate 204 of a patient's mouth. On the palate 204 a feature 205 is drawn. The

feature 205 shows where on the palate 204 and with which shape a part of a removable partial denture should be arranged. At present no teeth 202 are missing on the model 201, but one or more of the teeth 202 may be replaced with artificial teeth in a partial denture, for instance if some of the teeth are
5 broken, weak or dead.

The outline of the removable partial denture feature 205 may be drawn on a physical model 201 by a dental technician or it may be drawn digitally on a virtual model 201 shown on a computer screen.

10 A 3D scanning of the physical model 201 using e.g. a laser scanner for acquiring geometrical data of the model may only capture the data for the geometrical features of the model.

For acquiring the textural data of the feature(s) 205, e.g. the drawn outline of the partial denture, a 2D digital representation can be acquired by capturing
15 the 2D images of the model.

When both geometrical and textural data are acquired, 2D features can be derived from the textural data to be used in the modeling of the 3D object which should fit the scanned location.

20 Fig. 2c) shows the a texture image of the physical model 201 with teeth 202, gingival 203, and the palate 204 of a patient's mouth. On the palate 204 and around some of the teeth 202, features 205 have been drawn. The features 205 show where and with which shape on the palate 204 and around the teeth 202 a partial denture should be arranged. Only five teeth 202 are
25 present on the model 201, and thus several teeth are missing on the model 201, and one or more of the missing teeth will be replaced with artificial teeth in the partial denture.

The outline of the partial denture features 205 have been drawn on the physical model 201 by e.g. a dental technician or dentist.

30 This texture image clearly shows the features which are drawn physically and manually on the model.

For the 3D modeling of some cases, it may be advantageous to draw the lines on the physical model in different colors to increase to level of information that can be derived from the acquired 2D digital representation(s).

5

Fig. 2d) shows another result of a texture image or scan of the model 201 with teeth 202, gingival 203, and the palate 204 of a patient's mouth. On the palate 204 features 205 have been drawn. The features 205 show where on the palate 204 that a part of a partial denture should be arranged. Nine teeth
10 202 are present on the model 201, and thus several teeth are missing on the model 201, and one or more of the missing teeth can be replaced with artificial teeth in the partial denture.

The outline of the partial denture features 205 have been drawn on the physical model 201 by e.g. a dental technician or dentist.

15

This texture image or scan clearly shows the features which are drawn physically and manually on the model.

Fig. 2e) is a zoom of the feature 205 seen in fig. 2d). The texture images are acquired using a 5 megapixel camera.

20

Fig. 3 shows an example of 3D modeling of a removable partial denture.

Fig. 3a) shows the removable partial denture 306 as seen from above.

Fig. 3b) shows the removable partial denture 306 in a side view.

25

Fig. 3c) shows an example of blocking out of undercuts 307 and exposing undercuts 307 for clasp 308 planning.

After the physical model with the drawn texture, e.g. lines, has been scanned, the removable partial denture 306 can be digitally modeled.

30

First a dental 3D scanner can be used to scan a physical gypsum model or alternatively an impression to provide the 3D digital representation of the location where the removable partial denture 306 is to be worn by the patient.

The scanner may scan geometrical features and textural features for securing an optimal image of the model 301 with teeth 302 and with the drawn texture 305, such as lines, for designing all the removable partial denture components with high accuracy in a few minutes, such as only 100 seconds.

5 The removable partial denture components comprise clasps 308 for attachment to the teeth 302, retention grids 309 which stretches out on the gums where there are no teeth, the major connector 310 on the palate connecting the retention grids 309 and the clasps 308.

Fig. 3a), 3b) and 3c) show that the digital design process may intuitively
10 mimic the manual steps, including blocking out of undercuts 307, exposing undercuts 307 for clasp 308 planning, retention grid 309 design with automatic resin gap 311, application of major connector 310 and, finally, addition of clasps 308 to the grid structure 309. The completely virtual workflow enables the dental technician to work on-screen as if he/she were
15 using traditional wax tools.

When designing the retention grid 309, the first step may be to select from a list of pre-defined grid patterns and apply mesh to the digital model for a perfect fit. Then the next step may be marking the area for the major connector 310 using e.g. a fast edit tool. The system automatically designs
20 for optimal strength.

If the lines, i.e. the textural features 305, have not already been drawn on the physical model, then the lines for clasp 308 placement may be virtually drawn. Predefined or customized clasps 308 are applied to the model, when
25 the lines are present. By means of an interactive preview fine-adjustment of each feature of the removable 306 can be performed through control points.

A 2D cross section of the 3D digital model 301 may be shown, and the line 312 indicates where a cross section can be made.

30

Modeling a removable partial denture 306 as shown here is a highly productive and reliable customization of removable partial dentures 306, providing labs with accurate digital control over the process while reducing production time and costs. The process may cover all the steps for optimal design of both metal and flexible frameworks.

5 The method provides a high degree of flexibility and a digital workflow that maps out the practiced processes familiar to laboratory technicians.

The digital design removes the need for second re-factory model-making saving both time and money. The system's high accuracy and measurement features provide complete dimensional control over clasp 308 and connector 10 310 design and ensure good results, such as high esthetics, easy removability, proper chewing, and a perfect fit.

The completely digital survey accurately identifies undercuts 307, facilitates virtual wax block-out for easy removability, and enables undercut 15 307 exposure for optimal clasp 308 design.

Thus the method provides faster and easier design of perfectly fitting partials 306, provides a fast partial design by reducing the manual process time, provides that the intuitive workflow maps out the manual process, provides that ideal block-out points and retention areas can be identified in record 20 time, reduces orders for readjustments and remakes, and increases dentist and patient satisfaction.

Fig. 4 shows an example of a modeled removable partial denture.

25 Fig. 4a) shows an example of a digital CAD model of the removable partial denture 406.

Fig. 4b) shows an example of the manufactured removable partial denture 406 attached to a model 401 of a patient's teeth 402, gingival 403 and palate 404.

30 The removable partial denture 406 comprises clasps 408 for attachment to the teeth 402, retention grids 409 which stretches out on the gums where

there are no teeth, the major connector 410 on the palate 404 connecting the retention grids 409 and the clasps 408.

5 Fig. 5 shows examples of a preparation margin line as a feature.
Fig. 5a) shows a CAD drawing of a die or tooth 502 which is prepared meaning that it has been grinded such that a restoration, such as a crown, can be placed on the tooth 502. The preparation of the tooth 502 provides a preparation margin line 505 which is a feature which can be detected as a
10 geometrical feature and/or as a textural feature when scanning or imaging the tooth 502. In fig. 5a), the preparation margin line 505 is also marked with a colored line, and at points on the line small markers 513 indicate the perpendicular direction of the margin line at that point. The arrow 514 indicate the overall perpendicular direction of the margin line 505 or the
15 insertion direction of the tooth 502.

Figs. 5b)-5e) show a number of texture images from different viewpoints of a die 502 which has been prepared meaning that it has been grinded such that a restoration, such as a crown, can be placed on the die 502. The
20 preparation of the die 502 provides a preparation margin line 505 which is a feature which can be detected as a geometrical feature and/or as a textural feature when scanning or imaging the tooth 502. The preparation margin line 505 is also sketched or drawn on the die 502 with a color creating contrast to the color of the die and/or the background.
25 The specular effects which are dominant in fig. 5d) can be removed by means of texture weaving between the different images.

Figs. 5f)-5i) show a number of texture scans from different viewpoints of another die 502 which has been prepared meaning that it has been grinded
30 such that a restoration, such as a crown, can be placed on the die 502. The preparation of the die 502 provides a preparation margin line 505 which is a

feature which can be detected as a geometrical feature and/or as a textural feature when scanning or imaging the tooth 502. The preparation margin line 505 is also sketched or drawn on the die 502 with a color creating contrast to the color of the die and/or the background.

5

Figs. 5j)-5m) show a number of texture scans from different viewpoints of an impression of a number of teeth, where one of the teeth is a prepared tooth 502. The impression of the prepared tooth 502 shows the preparation margin line 505 which is a feature which can be detected as a geometrical feature and/or as a textural feature when scanning or imaging the impression of the prepared tooth 502. The preparation margin line can also be sketched or drawn on the impression with a color creating contrast to the color of the impression and/or the background.

10

15

Fig. 6 shows an example of texture weaving.

Fig. 6a) shows an example where a number, e.g. three, texture images 615 have been acquired of a person's face from different viewpoints, and where the texture images 615 have been assembled into a composite or compound texture image. The transitions 616 between the different texture images 615 can be seen, since the colors or tones are not the same on the borders of the different images 615.

20

25

Fig. 6b) shows an example where the single texture images 615 from fig. 6a) have been subjected to texture weaving, such that the transitions 616 which were dominant in fig. 6a) cannot or hardly cannot be seen in the final processed texture image 617. The colors and tones of the different texture images 615 have been smoothed out in the final texture image 617 such that the colors and tones match at the borders of the different texture images 615.

30

Figure 7 shows an example of a setup for scanning a location using a first and a second light source. In this example, the system is configured for acquiring digital representations of a physical model or an impression of the location. In the following, the system is described in relation to a physical model of the location, but the description provided is equally valid for the acquisition of digital representations from an impression of the location.

5 The optical assembly 720 of the system comprises a first light source 721, a second light source 722 and first set of cameras 7231, 7232. The optical axis of the first light source and the optical axis of the second light source intersects in a scan volume. The scan plate 7241 is arranged such that a physical model 724 placed on this scan plate is within this scan volume and the physical model can be illuminated by light from the first light source 721 and from the second light source 722. The first set of cameras 7231, 7232 are arranged such that their photosensitive elements 7321, 7322 can receive light from the scan volume, such as light reflected from the physical model 15 724 placed on the scan plate 7241. The system further comprises mechanics, such as a positioning unit (not included in the figure for simplicity) for translating and/or rotating the scan plate 7241 and hence the physical model 724 and the optical assembly 720 relative to each other. The first light source 721 may be a monochromatic laser. The second light source 722 may be broadband light source, such as a white light source, or a light source providing light at multiple distinct wavelengths, such as a light source comprising a number of diodes emitting light at different wavelengths. For some applications, the light emitted from the second light source is preferably 25 diffusive allowing for a detailed detection of the texture of a feature on the physical model, such as e.g. surface roughness at a margin line.

The 3D digital representation comprising geometrical data may be acquired by scanning such a monochrome laser of the first light source 721 over the location 724 while recording the signals reflected from the location to the first set of cameras 7231, 7232.

30

The system can be used for the steps the method according to the present invention relating to acquiring the 2D digital representation comprising textural data and the 3D digital representations comprising geometrical data.

The system may be configured such that the 3D digital representations
5 comprising geometrical data is acquired before the 2D digital representation comprising textural data.

Both cameras of the first set of cameras may be used for the acquisition of a 2D image of the 2D digital representation comprising textural data, such that the time used for acquiring a 2D digital representation comprising a large
10 number of the 2D images is reduced. The use of 2D images acquired from both cameras may require a detailed knowledge of the position and orientation of the cameras relative to the location.

A desired coverage of the location may be obtained by acquiring the 2D
15 digital representation comprising texture data and the 3D digital representation comprising geometrical data of the location from a number of different viewpoints. The 3D digital representation may be acquired by collecting individual parts of the 3D digital representation from a number of viewpoints. The individual parts of the 3D digital representation may then be
20 merged to form the 3D digital representation comprising geometrical data of the location. Each individual part may be analyzed to detect a light pattern using a standard tracking algorithm. When the light pattern is known, potentially with sub-pixel precision, the corresponding 3D coordinates can be reconstructed using well-known projective geometry. A precise reconstruction
25 of the 3D coordinates usually requires a high quality of the cameras and light source calibration. Subsequently the 3D coordinates reconstructed from the individual parts relating of the 3D digital representation acquired at the same or at different viewpoints may be merged. The merging may be performed by combining the individual parts taking into consideration their relative position.
30 Finally the 3D coordinates may be triangulated using a standard triangulation algorithm to form the final geometry of the 3D digital representation.

A registration of a part of the 2D digital representation comprising textural data into the 3D digital representation of the location may provide a 3D model comprising textural data. The 2D images of the 2D digital representation comprising textural data may be registered into the 3D model one by one, or
5 the textural data from the one or more 2D digital representations may be combined to provide a 3D models feature which then can be applied to the 3D digital representations comprising geometrical data.

The acquired digital representations may be analyzed in a digital signal
10 processor or microprocessor. The analysis may be performed in real-time.

Figures 8 to 10 show schematic overviews of some configurations of the second light source that are capable of emitting light with its intensity
15 distributed over a range of wavelengths. Such configurations may be advantageous when the textural data of the features are defined using different colors.

When a feature is defined by e.g. a colored line drawn by a user on a physical model of the location, the feature will only provide a strong reflection
20 of light with a wavelength corresponding to the color of the line. For example, a red line on a physical model only reflects red light and the light emitted from the second light source must include wavelengths in the red range in order to have a reflection from the red line of this feature.

The examples of Figures 8 to 10 describe configurations where three colors
25 are used to define different parts of a feature or different feature, but this choice is only for illustrative purposes.

In Figure 8, the second light source 822 comprises an array of diodes comprising a number of first diodes 826 emitting light with a wavelength in
30 the red range, a number of second diodes 827 emitting light with a wavelength in the green range, and a number of third diodes 828 emitting

light with a wavelength in the blue range. A diffuser 825 is arranged to provide a diffusion of the light emitted from the array of diodes such that the physical model 824 arranged on the scan plate 8241 is illuminated by a beam 8221 comprising diffuse light from the second light source. The diffuser can
5 be fabricated from opalized plastic or glass of a few millimeters thickness. All diodes of the array are driven to emit light continuously by a control unit configured for controlling the array of diodes. The control unit is not shown in the figure for simplicity. The control unit can optionally also be configured for controlling the first set of cameras 8231, 8232. The first set of cameras 8231,
10 8232 are arranged to receive light reflected from the physical model 824 placed on the scan plate 8241.

The cameras 8231, 8232 of the first set of cameras are color cameras such that light at all the wavelengths emitted from the array of diodes can be detected by the camera and identified from the wavelength of the individual
15 signals.

Such a design of the optical assembly is advantageous for acquiring textural data from a physical model on which a first, a second, and a third feature are defined using red, green, and blue color, respectively. The red part of the 2D image acquired by the color cameras relates to the first feature, the green
20 part to the second feature, and the blue part to the third feature. The different parts in each acquired 2D image are hence related to the different features and information for all three features can be derived from one 2D image. Several color 2D images acquired from different relative viewpoints may still be needed in order to obtain the desired coverage.

25 This arrangement with continuously having light emitted from all three types of diodes, i.e. at all three wavelengths, in the second light source and color cameras in the first set of cameras may have the advantage that each acquired 2D digital representation of the physical model can provide textural data of features defined using the different colors. Acquisition of textural data
30 relating to different features can hence be performed in parallel.

Figure 9 shows a system where the array of diodes is similar to the array of diodes illustrated in Figure 8. The diodes of the array are however driven sequentially instead of continuously as described in Figure 8. The diodes may be driven such that the physical model at any time only is illuminated from one type of the diodes, i.e. illuminated with light at one wavelength only.

5 The control unit ensures that the first, second and third diodes 926, 927, 928 emits light sequentially, such that the physical model is illuminated by a sequence of light signals, where the sequence e.g. may be first wavelength, second wavelength, third wavelength. The sequence may be repeated a

10 number of times, such as one for each relative arrangement physical model and the second light source and the cameras. The diffuser 925 of the second light source 922 provides that the light in the beam 9221 emerging from the second light source is diffusive.

The acquisition of 2D digital representations using the cameras 9231, 9232 and the driving of the diodes of the second light source 922 is timed such that

15 a 2D digital representation is acquired for every step in the sequence of light signals. A 2D digital representation is hence acquired for each of the wavelengths that is emitted by the array of diodes. Since each of these 2D digital representations is correlated to a single wavelength from the second

20 light source, there is no need for color cameras, and the cameras 9231, 9232 may be monochrome cameras.

A colored line will appear dark grey in a 2D image acquired by the monochrome cameras when the second light source emits light with a wavelength which is outside the wavelength range where this color reflects

25 light. A line having a color which matches a wavelength of the light emitted from the second light source will appear light gray in the acquired 2D image. Standard procedures for processing a grayscale 2D image comprising light grey and dark grey lines can then be applied to identify the color of the drawn

30 lines from their monochrome appearance in 2D digital representations that are acquired while illuminating the physical model with light at the different wavelengths of the second light source.

This arrangement of the second light source and the first set of cameras may have the advantage that a physical model can be scanned using three colors to provide three times the information which can be assessed with one color only, while still using the more simple monochrome cameras. Information
5 relating to three different features from the same physical model of the location may be obtained and distinguished from each other using a monochrome camera.

For the green channel, this approach may double the amount of information, while for the blue and red channels, we have 4 times as much information.
10 Totally, this gives $0.5 \cdot 2 + 2 \cdot 0.25 \cdot 4 = 3$ times.

The reduced complexity of the scanner when using monochrome cameras may be at the expense of an extended process time since the textural data are acquired sequentially instead of in parallel as seen in Figure 8.
15

In Figure 10, the second light source 1022 comprises a white light source 1030 and a diffuser 1025 arranged to provide a diffusion of the light emitted from the white light source 1030 to provide a diffused light beam 10221. The
20 first set of cameras 10231, 10232 are color cameras.

The white light source 1030 is capable of emitting light over a wavelength range which covers the blue to red wavelengths, such that red, green, and blue color can be used to identify different features on the physical model. The cameras 10231, 10232 may be color cameras, in which case the system
25 only differs from that of Figure 8 with respect to the second light source.

An alternative to using color cameras, is to use monochrome cameras and place filters, such as Bayer filters in the optical path between the scan
30 volume and the cameras. The Bayer filters then provide a correlation between the position on the photosensitive elements 10321, 10322 where a

signal is received and the wavelength of the received signal. Only a number of the pixels of the photosensitive elements 10321, 10322 will receive red light, while others will receive only green light and others will only receive blue light. A calibration wherein the photosensitive elements 10321, 10322 are exposed to monochromatic light sources (red, green, blue) through the Bayer filters establishes the wavelength-pixel correlation, such that the signals detected by the different pixels of the photosensitive elements 10321, 10322 are linked to the different colors of the light reflected by the physical model 1024. The correlation may be stored in the first set of cameras or in a digital signal processor unit used for analysing the 2D digital representations acquired by the first set of cameras.

In Figure 10, the filters could be arranged between the scan plate 10241 and the photosensitive elements 10321, 10322 of the cameras 10231, 10232.

The white light source 1030 should then preferably be capable of emitting light over a wavelength range which covers the blue to red wavelengths, i.e. the entire wavelength span of the Bayer filter.

This design of the system has the advantage, that the electronics is more simple than that of the design illustrated in Figure 9 and that the representations can be acquired as fast as in the design of Figure 8.

Color cameras are often made from a monochrome CCD chip and a Bayer filter arranged in front of this chip.

Figure 11 shows pictures of the optical assembly of a system according to the present invention.

The pictures are taken from different angles and show the components of the optical assembly. The first light source 1121 is a red laser emitting light at a wavelength of 650 nm. The cameras 11231, 11232 of the first set of cameras are arranged at opposite sides of the first light source 1121 to enable a stereo imaging of the surface of a physical model 1124 arranged at the scan

plate 11241. The second light source 1122 has a diffuser 1125 arranged to provide that the emitted light is diffuse. Here the 3D digital representation comprising geometrical data and the 2D digital representation comprising textural data are acquired using the first set of cameras 11231, 11232. The
5 first light source 1121 and the second light source 1122 are arranged at a different angles relative to the scan plate 11241 such that light from both light sources can be reflected from a physical model 1124 at the scan plate towards the cameras 11231, 11232.

In one configuration of the optical assembly, the second light source 1122
10 has diodes that emits light at e.g. red, green and blue wavelengths, where the diodes are driven to emit light sequentially. The cameras 11231, 11232 may then be monochrome cameras.

In one configuration of the optical assembly, the second light source 1122 has diodes that continuously emits white light during the acquisition of the 2D
15 digital representation. The cameras 11231, 11232 may then be color cameras, such that features marked in different colors can be distinguished in the acquired 2D digital representation. The color cameras 11231, 11232 may have color filter arrays (CFA) arranged in a Bayer-type arrangement in front of their photosensitive element. In this case, the spatial resolution
20 provided by light at green wavelengths is twice the spatial resolution provided by light at red and blue wavelengths, such that for some applications it could be preferred to use a green laser instead of a red laser as the first light source 1121.

25

Figure 12 shows examples of an arrangement of the array of diodes in the second light source.

In figure 12b is illustrated an arrangement of red diodes 12501, green diodes 12502 and blue diodes 12503 in a 9x12 array on a circuit board 1250 with the
30 red, green and blue diodes arranged similar to the distributions of these colors in a Bayer filter.

Figure 12b shows a picture of a circuit board 1250 of second light source, where the white diodes 12504 are arranged in a 4X10 array.

5 Figure 13 shows a schematic of a system using two-photon fluorescence for acquiring a combined 3D digital representation comprising both geometrical data and textural data.

A feature is defined on the physical model 1324 of the location using a paint or ink comprising a fluorescent material configured for two-photon excitation and the first light source 1321 emits light at a wavelength in the infrared range.
10 When two infrared photons are absorbed, a photon in the visible range is emitted from the feature.

The 3D representation acquired by detecting the reflected infrared photons from the location can directly be combined with the 3D representation
15 acquired by detecting the fluorescence from the feature.

A feature comprising a fluorescent material having an excitation band including the wavelength of the first light source 1321 may provide a Stoke shift of the wavelength of the first light source. In contrast, the light reflected
20 from the location maintains its wavelength. Using various optical configurations known to the skilled person it is then possible to extract both the geometrical data and the texture data using only the first light source to illuminate the location.

Since the fluorescence typically is orders of magnitudes weaker than the reflected light it may be advantageous to detect the reflected light using the first set of cameras, while the fluorescence signal is detected using a second set of cameras. The second set of cameras may comprise a filter arranged to block light within the wavelength of the first light source, or filters may be placed between the location and the second set of cameras.

30

Several parts of the optical assemblies illustrated in Figures 7 to 13 can also be integrated in a handheld scanner, where the change between different relative arrangements of the system and the location (or a model or impression of the location) is obtained by moving the handheld scanner. The integration in a handheld scanner may require that some of the components of the system are reduced in size. In a handheld scanner system, a digital signal processor or a microprocessor configured for analyzing the acquired 2D digital representations may be placed in the scanner handle or in a separate processing box.

10

Figure 14 shows contrast enhancement for 2D images of a physical model of the location.

Here the location is a tooth preparation and the 3D object a restoration, such as a crown or a bridge. The physical model is a die of the prepared tooth on which the margin line has been marked using a pen. Each 2D image of the acquired 2D digital representation is processed to enhance the visibility of the margin line (the feature) before the 2D digital representation is projected onto the 3D digital representation comprising geometrical data. Some image processing may also be performed after this projection. For this physical model, the contrast enhancement appears to be best for alpha values in the range 0.2 to 0.6. When the 3D spline of the margin line has been extracted from the textural data, the restoration is modeled using standard techniques

25

Figure 15 shows a texture atlas for a physical model of a tooth preparation. The texture atlas is formed by combining image patches from 2D images acquired of the physical model. The images patches 15421, 15422, 15423, 15424, and 15425 covers the margin line 1543 marked on the physical model using a pencil, with the numbering indicating the order of the 2D images along the margin line.

30

Texture weaving has been applied to assure that the texture of the image patches is seamless, which e.g. can be seen in 2D image 15425 where the bright elongated section 15426 is due to the somewhat brighter appearance of the neighboring patch 15421.

- 5 When projected onto the 3D digital representation, the position of the feature, i.e. the margin line 1543, can be extracted in the form of a 3D spline.

10 Figure 16 shows screen shots from computer software used for implementing the method according to the present invention.

The feature is here a margin line drawn on a physical model of a prepared tooth. A 3D digital representation comprising geometrical data 1644 and a combined 3D digital representation comprising geometrical data and textural data 1645 as seen from the same (virtual) position relative to the digital representations. In the combined 3D digital representation where the textural data are projected onto the 3D digital representation comprising geometrical data, the margin line 1643 can be seen. From this combined 3D digital representation, a 3D spline of the margin line can be extracted using computer implemented algorithms.

20

Figure 17 shows screen shots from computer software used for implementing the method according to the present invention.

25 This figure shows part of a 3D spline extracted from the textural data of the acquired 2D digital representation. The 3D spline 1746 following the feature of the location, i.e. the margin line, is derived automatically from the texture data of the 2D digital representation by projecting the 2D digital representation onto the 3D digital representation comprising geometrical data.

Figure 17b shows a close-up of the extracted 3D spline 1746 with control points 1747. The form of the 3D spline can be adjusted by moving the control points 1747 relative to the 3D digital representation of the tooth preparation. The 3D modeling of the restoration, i.e. of the 3D object, may comprise a
5 defining the surfaces of the restoration based on the 3D digital representation comprising geometrical data and from a target shape of the restoration, while using the 3D spline to define the shape of the restoration in the part facing the margining line.

10

Although some embodiments have been described and shown in detail, the invention is not restricted to them, but may also be embodied in other ways within the scope of the subject matter defined in the following claims. In particular, it is to be understood that other embodiments may be utilised and
15 structural and functional modifications may be made without departing from the scope of the present invention.

20

In device claims enumerating several means, several of these means can be embodied by one and the same item of hardware. The mere fact that certain
20 measures are recited in mutually different dependent claims or described in different embodiments does not indicate that a combination of these measures cannot be used to advantage.

25

It should be emphasized that the term "comprises/comprising" when used in
25 this specification is taken to specify the presence of stated features, integers, steps or components but does not preclude the presence or addition of one or more other features, integers, steps, components or groups thereof.

30

The features of the method described above and in the following may be
30 implemented in software and carried out on a data processing system or other processing means caused by the execution of computer-executable

instructions. The instructions may be program code means loaded in a memory, such as a RAM, from a storage medium or from another computer via a computer network. Alternatively, the described features may be implemented by hardwired circuitry instead of software or in combination with
5 software.

Claims:

1. A method for 3D modeling of a 3D object adapted to be inserted in or worn by a patient, wherein the method comprises :

5

- acquiring a 3D digital representation of at least a part of the location where the 3D object is adapted to be arranged, where the 3D digital representation comprises geometrical data of the location;

10

- acquiring a 2D digital representation of at least a part of the location where the object is adapted to be arranged, where the 2D digital representation comprises textural data relating to one or more features of the location;

15

where a desired coverage of the location is obtained by acquiring each of the 2D digital representation comprising textural data and the 3D digital representation comprising geometrical data from one or more different viewpoints relative to the location;

20

- aligning the 2D digital representation comprising textural data and the 3D digital representation comprising geometrical data;

- combining at least a part of the 2D digital representation comprising textural data and the 3D digital representation comprising geometrical data to obtain a combined 3D digital representation comprising both geometrical data and textural data of the location;

25

- visualizing the combined 3D representation comprising the geometrical data and the textural data of the location; and

- 3D modeling the 3D object such that the modeled 3D object is adapted to be inserted in or worn by a patient, where said 3D modeling applies information of the one or more features from the acquired 2D digital representation comprising textural data.

2. The method according to the preceding claim, wherein the method comprises extracting the information of the one or more features from the 2D digital representation comprising textural data.
- 5 3. The method according to any of the preceding claims, wherein extracting the information of the one or more features is performed automatically.
4. The method according to any of the preceding claims, wherein the 2D digital representation is acquired by acquiring one or more 2D images of a
10 physical model of the location or of an impression of the location, and/or by acquiring 2D images directly of the location.
5. The method according to any of the preceding claims, wherein the part of the 2D digital representation comprising textural data which is combined with
15 the 3D digital representation comprises one or more sections of the 2D images of the acquired 2D digital representation.
6. The method according to any of the preceding claims, wherein the one or more sections of the 2D images are the sections that relates to the feature of
20 the location.
7. The method according to any of the preceding claims, wherein the method comprises translating one or more 2D features from the 2D digital representation comprising textural data into one or more 3D features.
25
8. The method according to any of the preceding claims, wherein the one or more 2D features comprises a 2D point, a 2D curve or a 2D spline.
9. The method according to any of the preceding claims, wherein the one or
30 more 3D features comprises a 3D point, a 3D curve or a 3D spline.

10. The method according to any of the preceding claims, wherein combining the 2D digital representation and the 3D digital representation to obtain a combined 3D digital representation comprises projecting the extracted information from the 2D digital representation onto the 3D digital
5 representation.

11. The method according to any of the preceding claims, wherein the 3D digital representation is acquired by scanning a physical model of the location, by scanning an impression of the location, and/or by performing a
10 direct scanning of the location.

12. The method according to any of the preceding claims, wherein acquiring the 3D digital representation comprising geometrical data of the location and the 2D digital representation comprising textural data of the location is
15 performed by means of a system adapted for acquiring geometrical data and textural data.

13. The method according to any of the preceding claims, where the system comprises an acquisition unit configured for acquiring the digital
20 representations of the location and a positioning unit configured for positioning the location relative to the acquisition unit, and the method comprises arranging the location, a physical model of or an impression of the location, in relation to the system.

25 14. The method according to any of the preceding claims, where the location is automatically repositioned relative to the acquisition unit during the acquisition of the 2D digital representation comprising textural data and during the acquisition of the 3D digital representation comprising geometrical data, such that at least one of the digital representations is acquired
30 automatically from a number of different viewpoints and the desired coverage is obtained.

15. The method according to any of the preceding claims, where said positioning unit provides the automatic repositioning of the location relative to the acquisition unit.
- 5 16. The method according to any of the preceding claims, wherein the 3D modeling of the 3D object is performed automatically based on the one or more features.
- 10 17. The method according to any of the previous claims, wherein the 3D modeling comprises defining one or more edges of the 3D object based on the information.
- 15 18. The method according to any of the previous claims, wherein the method comprises providing a 3D model of the 3D object, and the 3D modeling comprises adapting the provided 3D model of the 3D object based on the information.
- 20 19. The method according to any of the previous claims, wherein said provided 3D model is provided from a library.
- 20 20. The method according to any of the previous claims, wherein the adapting of the provided 3D model of the 3D object comprises shaping the edges of the provided 3D model of the 3D object based on the information.
- 25 21. The method according to any of the preceding claims, wherein the 3D object is adapted to replace an anatomical object of the patient's body.
- 30 22. The method according to any of the preceding claims, wherein the 3D object is adapted to be inserted in a body cavity of the patient.

23. The method according to any of the preceding claims, wherein the location is the mouth of the patient.
24. The method according to any of the preceding claims, wherein the
5 location is one or more teeth of the patient.
25. The method according to any of the preceding claims, wherein the location is an ear canal of the patient.
- 10 26. The method according to any of the preceding claims, wherein extracting information of one or more features of the location comprises feature detection.
27. The method according to any of the preceding claims, wherein the
15 extraction of information of features is performed by detecting features which are present on the combined 3D digital representation and/or on the 3D digital representation comprising geometrical data.
28. The method according to the preceding claim, wherein feature detection
20 comprises examining every pixel in one or more of the digital representations to detect if there is at least part of a feature present at that pixel.
29. The method according to any of the preceding claims, wherein the one or
25 more features are selected from the group of lines, contours, curves, edges, ridges, corners, and points.
30. The method according to any of the preceding claims wherein the feature
30 comprises identification marks arranged within a substantially closed edge of the feature

31. The method according to any of the preceding claims wherein said identification marks are selected from the group of concentrically arranged circles, crosses, squares, triangles, the number of elements in the identification mark, such as the number of dots.

5

32. The method according to any of the preceding claims, wherein the one or more features comprises a margin line of a prepared tooth or die.

10 33. The method according to any of the preceding claims, wherein the one or more features comprises the shades of the patient's teeth.

15 34. The method according to any of the preceding claims, wherein the one or more features are drawn on the location, on a physical model of the location, or on an impression of the location by a user prior to the acquisition of the 2D digital representation comprising textural data.

20 35. The method according to any of the preceding claims, wherein the 3D object comprises a removable partial denture, and the one or more features are major connectors, clasps and/or retention grids, such that the 3D modeling comprises defining one or more edges of the removable partial denture from the 3D feature.

25 36. The method according to any of the preceding claims, wherein the 3D object comprises an orthodontic appliance or bracket, and the one or more features are bracket position(s), screw position(s), metal framework, plastic shelves, shells, bite plates, push rods, and/or springs.

30 37. The method according to any of the preceding claims wherein the 3D modeling comprises defining the bracket positions and/or the screw position from the 3D feature.

38. The method according to any of the preceding claims, wherein different features are drawn with different colors by the user.
39. The method according to any of the preceding claims, wherein the
5 feature is a borderline between different structures of the location.
40. The method according to any of the preceding claims, wherein the feature is a borderline between different materials of the location.
- 10 41. The method according to any of the preceding claims, wherein acquiring the 3D digital representation comprising geometrical data and acquiring the 2D digital representation comprising textural data are performed sequentially.
42. The method according to any of the preceding claims, wherein at least
15 one of the digital representations is acquired by illuminating at least part of the location, a physical model of the location, or an impression of the location with light.
43. The method according to any of the preceding claims, wherein the light
20 used to acquire at least one of the digital representations is multispectral light comprising light at N wavelengths, wherein the number N is equal to or larger than 2.
44. The method according to any of the preceding claims, wherein the
25 method comprises using different colors or color codes to identify different features, where the different colors or color codes correspond to the N wavelengths of the multispectral light.
45. The method according to any of the preceding claims, wherein the N
30 wavelengths in the multispectral light are provided in a sequence.

46. The method according to any of the preceding claims, wherein N is 3 such that the multispectral light comprises light at a first wavelength, light at a second wavelength, and light at a third wavelength.
- 5 47. The method according to any of the preceding claims, wherein the sequence is first wavelength, second wavelength, and third wavelength
48. The method according to any of the preceding claims, wherein the first, second and third wavelengths are in the red, green, and blue range of
10 wavelengths, respectively.
49. The method according to any of the preceding claims, wherein the N wavelengths in the multispectral light are provided simultaneously.
- 15 50. The method according to any of the preceding claims, wherein the N wavelengths in the multispectral light are provided in a white light source.
51. The method according to any of the preceding claims, wherein a 2D image is acquired for each of said N wavelengths.
20
52. The method according to any of the preceding claims, wherein a 2D image is acquired for each of the red, green and blue light.
53. The method according to any of the preceding claims, wherein the 2D
25 images acquired for each of the N wavelengths in the multispectral light are stitched together into a common 2D image, such that the 2D digital representation comprises one or more common 2D images, each common 2D image comprising 2D images acquired at each of the N wavelengths.
- 30 54. The method according to any of the preceding claims, wherein the method comprises texture weaving, which comprises weaving the one or

more features together between neighbor 2D images based on the textural data of the 2D digital representation.

55. The method according to any of the preceding claims, wherein the
5 method comprises laser modulation of the light used for acquiring the 3D digital representation comprising geometrical data.

56. The method according to any of the preceding claims, wherein acquiring
the geometrical data is performed by means of a first light source, and
10 acquiring the textural data is performed by means of a second light source.

57. The method according to any of the preceding claims, wherein the
second light source comprises an array of diodes, where the array of diodes
comprises a number of first diodes, a number of second diodes and a
15 number of third diodes, where the first, second diodes and third diodes are adapted to emit light at a first, second and third wavelength, respectively.

58. The method according to any of the preceding claims, wherein the
second light source comprises a diffuser arranged to provide a diffusion of
20 the emitted light, such as a diffusion of the light emitted from a white light source or from an array of red, green and blue diodes.

59. The method according to any of the preceding claims, wherein the
positioning unit comprises at least a two-axis motion system such that the
25 positioning of the location during the acquisition of the 3D digital representation comprising geometrical data and the 2D digital representation comprising textural data is performed automatically by means of the at least a two-axis motion system.

60. The method according to any of the preceding claims, wherein the method comprises providing a face scan of the patient for facilitating visualizing the result of the modeling of the 3D object.
- 5 61. The method according to any of the preceding claims, wherein the 3D digital representation comprising geometrical data of the location, and/or the 2D digital representation comprising textural data of the location is/are obtained by means of a 3D face scan.
- 10 62. The method according to any of the preceding claims, wherein the method is adapted to be used for 3D modeling within dentistry.
63. The method according to any of the preceding claims, wherein dentistry comprises restorations, implants, orthodontics, such as bracket placement and appliances, and removable partial dentures.
- 15 64. The method according to any of the preceding claims, wherein the method is adapted to be used for 3D modeling of hearing aid devices.
- 20 65. The method according to any of the preceding claims, wherein the feature defines the boundary of an inner face or an outer face of the hearing aid device, the position or cross sectional shape of the vent, or an ID-tag for the hearing aid device.
- 25 66. The method according to any of the previous claims, wherein said information is extracted by an operator from the visualized combined 3D representation comprising both geometrical data and textural data.
- 30 67. The method according to any of the preceding claims, wherein the method is implemented on a computer program product comprising program code means for causing a data processing system to perform the method of

any one of the preceding claims, when said program code means are executed on the data processing system.

5 68. A method for 3D modeling of a 3D object adapted to be inserted in or worn by a patient, wherein the method comprises:

- acquiring a 3D digital representation of at least a part of a location at which the object is adapted to be arranged, where the 3D digital representation
10 comprises geometrical data of the location;

- acquiring a 2D digital representation of at least a part of the location where the object is adapted to be arranged, where the 2D digital representation comprises textural data of the location;

where the acquisition of the 2D digital representation comprising textural data
15 and of the 3D digital representation comprising geometrical data is performed by repositioning the location and acquisition means relative to each other for obtaining a desired coverage of the location;

- aligning and combining at least a part of the 2D digital representation comprising textural data and the 3D digital representation comprising
20 geometrical data to obtain a combined 3D digital representation comprising both geometrical data and textural data of the location;

- visualizing the combined 3D representation comprising the geometrical data and the textural data of the location; and

- applying information of one or more features from the 2D digital
25 representation comprising textural data of the location, when 3D modeling the 3D object.

69. The method according to any of the preceding claims, where the location is automatically repositioned relative to an acquisition unit during the acquisition of the 2D digital representation comprising textural data and during the acquisition of the 3D digital representation comprising geometrical data, such that at least one of the digital representations is acquired automatically from a number of different viewpoints and the desired coverage is obtained.

70. A computer program product comprising program code means for causing a data processing system to perform the method of any one of the preceding claims, when said program code means are executed on the data processing system.

71. A computer program product according to the previous claim, comprising a computer-readable medium having stored there on the program code means.

72. A system for 3D modeling of a 3D object adapted to be inserted in or worn by a patient, wherein the system comprises:

- an illumination unit configured for illuminating at least part of a scan volume of the system;
 - an acquisition unit configured for acquiring a 2D digital representation comprising textural data and a 3D digital representation comprising geometrical data of a location arranged in the scan volume;
 - a first digital signal processor unit configured for:
 - analyzing the acquired 2D digital representations and 3D digital representations,
 - aligning the 2D digital representation and the 3D digital representation;
- and

- combining at least part of the 2D digital representation and the 3D digital representation to obtain a combined 3D digital representation comprising both geometrical data and textural data of the location;
- a visualization device for visualizing the combined 3D representation comprising the geometrical data and the textural data of the location; and
- a second digital signal processor unit configured for 3D modeling the 3D object such that the modeled 3D object is adapted to be inserted in or worn by a patient, where said 3D modeling comprises applying information from the acquired 2D digital representation.

10

73. The system according to claim 72, wherein parts of the system, such as the acquisition unit, the positioning unit, and the first and second light sources, are provided in a 3D scanner.

15

74. The system according to claim 72 or 73, wherein the first and/or the second digital signal processor unit is configured for extracting the information of the one or more features from the 2D digital representation.

20

75. The system according to any of claims 72 to 74, wherein the first and second digital processor units are integrated parts of a digital signal processing device.

25

76. The system according to any of claims 72 to 75, wherein the acquisition unit comprises:

- means for acquiring a 3D digital representation of at least a part of a location arranged in said scan volume, where the 3D digital representation comprises geometrical data of the location; and

- means for acquiring a 2D digital representation of at least a part of a location arranged in said scan volume, where the 2D digital representation

30

- comprises textural data of the location.

77. The system according to any of claims 72 to 76, wherein the acquisition unit comprises a first set of cameras arranged arranged to receive light from the scan volume and to acquire both said 3D digital representation comprising geometrical data and said 2D digital representation comprising
5 textural data from a location.

78. The system according to any of claims 72 to 77, wherein the illumination unit comprises a first light source adapted for providing light for the acquisition of geometrical data of a location, and a second light source
10 adapted for providing light for the acquisition of textural data.

79. The system according to any of the claims 72 to 78, wherein the optical axis of the first light source and the optical axis of the second light source intersects in the scan volume.
15

80. The system according to any of claims 72 to 79, wherein the first light source comprises a monochromatic laser emitting light at a first laser wavelength.

20 81. The system according to any of claims 72 to 80, wherein the first laser wavelength is in the green range of wavelengths, in the red range of wavelengths, or in the blue range of wavelengths, or in the infrared range of wavelengths.

25 82. The system according to any of claims 72 to 81, wherein the second light source comprises a broadband light source, such as a white light source.

83. The system according to any of claims 72 to 82, wherein the acquisition unit is configured for acquiring textural data for N different features of a
30 location, where each feature has a unique color or color code, and for

distinguishing between said N different features based on said color or color code.

5 84. The system according to any of claims 72 to 83, wherein the second light source is configured for emitting light that allows features having a unique color or color code to be identified from an acquired 2D digital representation based on the wavelength of the light emitted from the second light source.

10 85. The system according to any of claims 72 to 84, wherein the second light source comprises an array of diodes, where the array of diodes comprises a number of first diodes, a number of second diodes and a number of third diodes, where the first, second diodes and third diodes are adapted to emit light at a first, second and third diode wavelength, respectively.

15 86. The system according to any of claims 72 to 85, wherein the second light source comprises a diffuser arranged to provide a diffusion of the emitted light.

20 87. The system according to any of claims 72 to 86, wherein at least one of the cameras in the first set of cameras comprises a color camera comprising a color filter array (CFA) arranged in a Bayer-type arrangement in front of a photosensitive element configured to detect electromagnetic signals

25 88. The system according to any of claims 72 to 87, wherein at least one of the cameras in the first set of cameras is a monochrome camera.

89. The system according to any of claims 72 to 88, wherein the system comprises a scan plate arranged such that a location arranged on said scan plate is positioned in said scan volume.

30

90. The system according to any of claims 72 to 89, wherein the system comprises a positioning unit configured for positioning the location in a number of different positions and/or orientations relative to the acquisition unit.

5

91. The system according to any of claims 72 to 90, wherein the positioning unit is configured for at least two-axis motion of the scan plate such that acquisition of the 3D digital representation comprising geometrical data and of the 2D digital representation comprising textural data from a number of viewpoints can be performed automatically.

10

92. The system according to any of claims 72 to 91, wherein the system comprises a control unit configured for controlling the array of diodes and the positioning unit.

15

93. The system according to any of claims 72 to 92, wherein the control unit is configured to provide that the first, second and third diodes emits light sequentially, such that a sequence of light signals are emitted.

20

94. The system according to any of claims 72 to 93, wherein the sequence is first wavelength, second wavelength, and third wavelength.

25

95. The system according to any of claims 72 to 94, wherein the control unit is configured to provide that the sequence is repeated a number of times, such as one time for each relative arrangement of the optical assembly and the scan plate.

30

96. The system according to any of claims 72 to 95, wherein the first, second and third diodes are arranged according to a Bayer arrangement.

30

97. The system according to any of claims 72 to 96, wherein the digital signal processor is configured for real-time analysis of the acquired 2D digital representations and 3D digital representations.

- 5 98. A system for performing 3D modeling of a 3D object adapted to be inserted in or worn by a patient, wherein the system comprises:
- means for acquiring a 3D digital representation of at least a part of the location where the 3D object is adapted to be arranged, where the 3D digital representation comprises geometrical data of the location;
 - 10 - means for acquiring a 2D digital representation of at least a part of the location where the object is adapted to be arranged, where the 2D digital representation comprises textural data relating to one or more features of the location;
- where a desired coverage of the location is obtained by acquiring each of the
- 15 2D digital representation comprising textural data and the 3D digital representation comprising geometrical data from a number of different viewpoints relative to the location;
- means for aligning the 2D digital representation comprising textural data and the 3D digital representation comprising geometrical data;
 - 20 - means for combining at least a part of the 2D digital representation comprising textural data and the 3D digital representation comprising geometrical data to obtain a combined 3D digital representation comprising both geometrical data and textural data of the location;
 - means for visualizing the combined 3D representation comprising the
 - 25 geometrical data and the textural data of the location; and
 - means for 3D modeling the 3D object such that the modeled 3D object is adapted to be inserted in or worn by a patient, where said 3D modeling applies information of the one or more features from the acquired 2D digital representation comprising textural data.

30

1/28

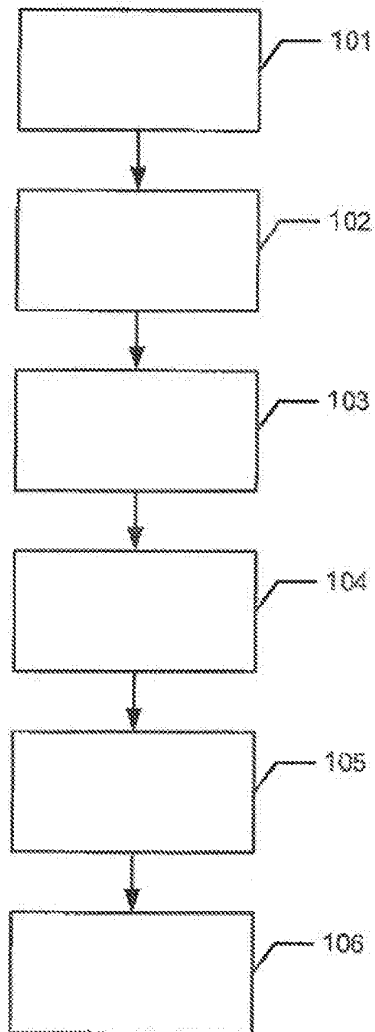
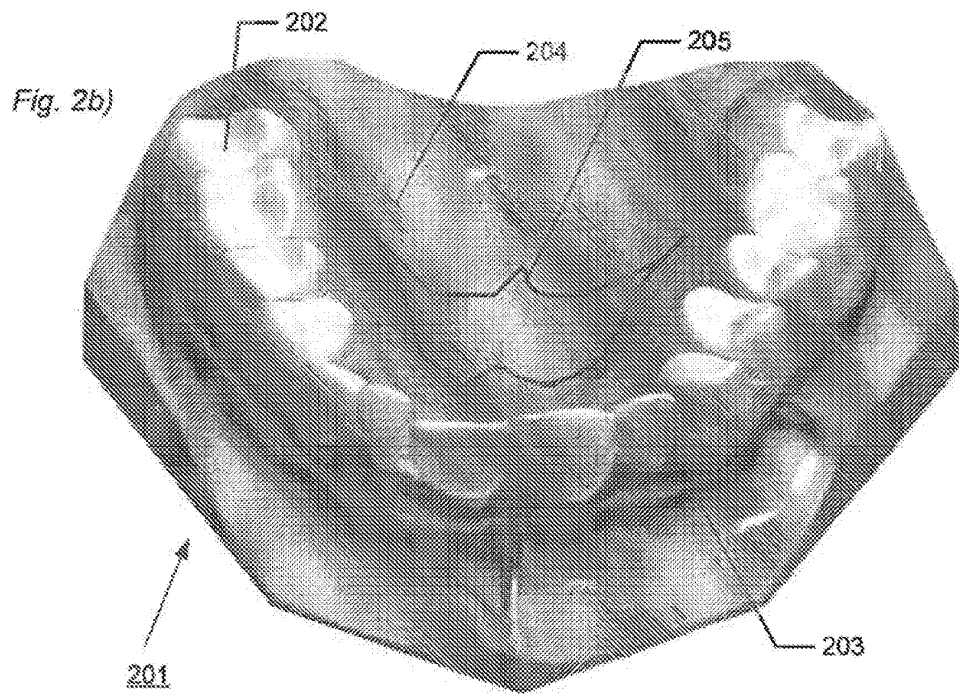
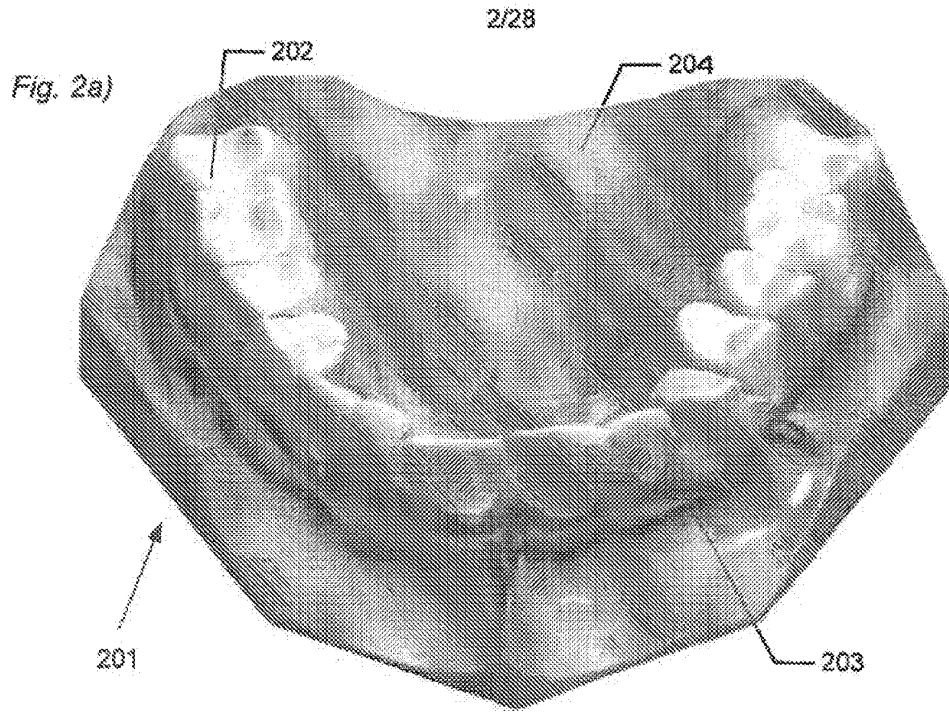

Fig. 1



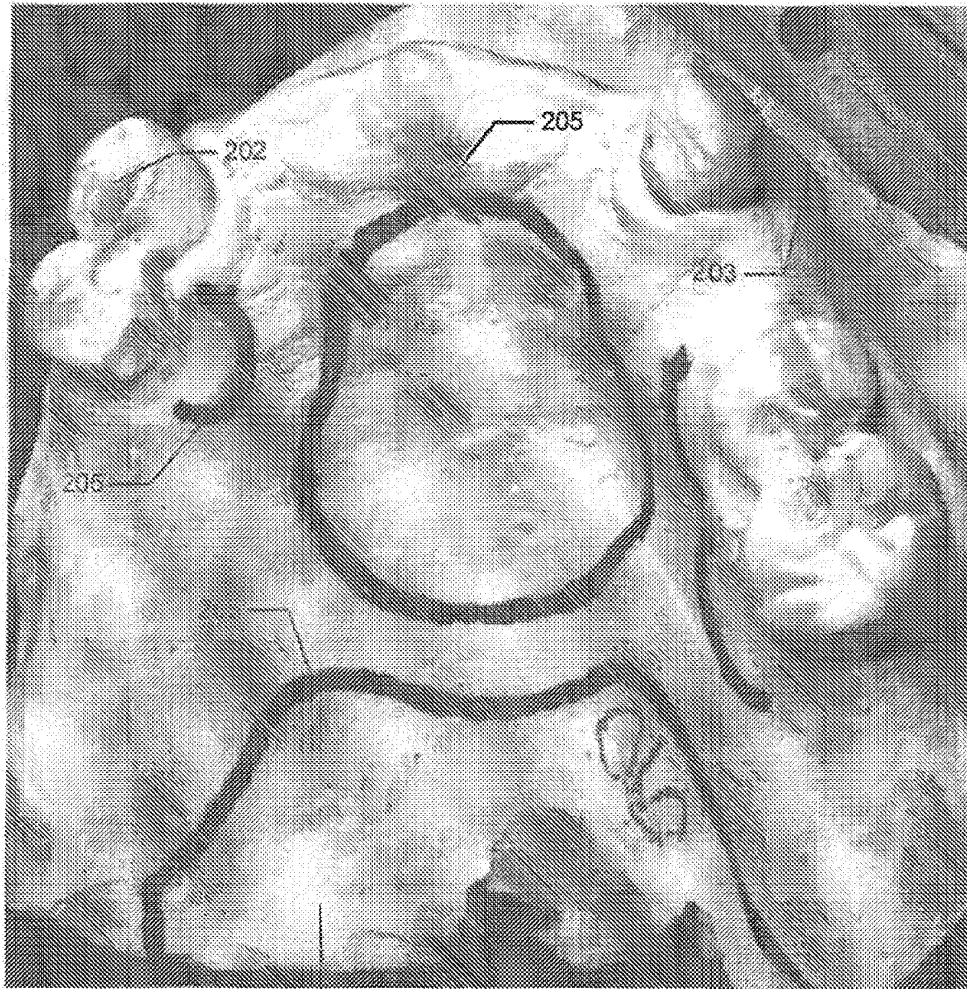

Fig. 2c)

201

Fig. 2d)

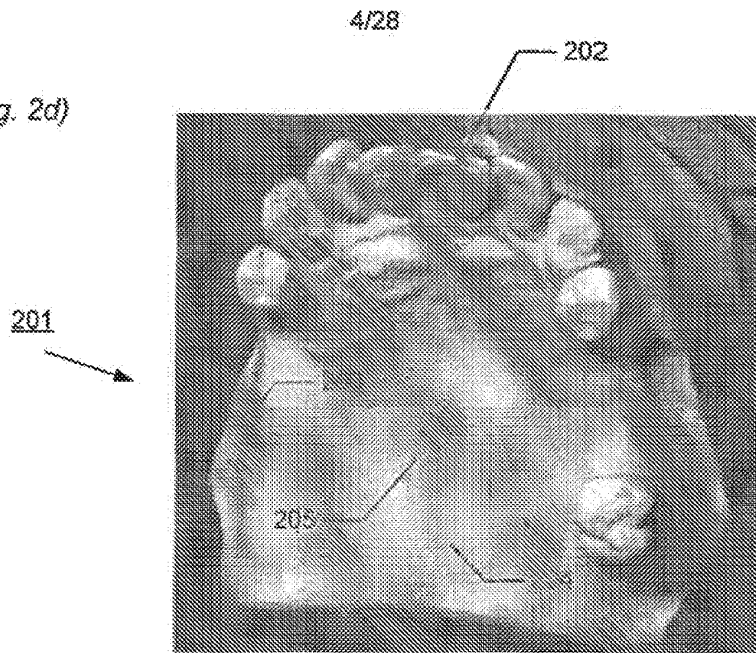
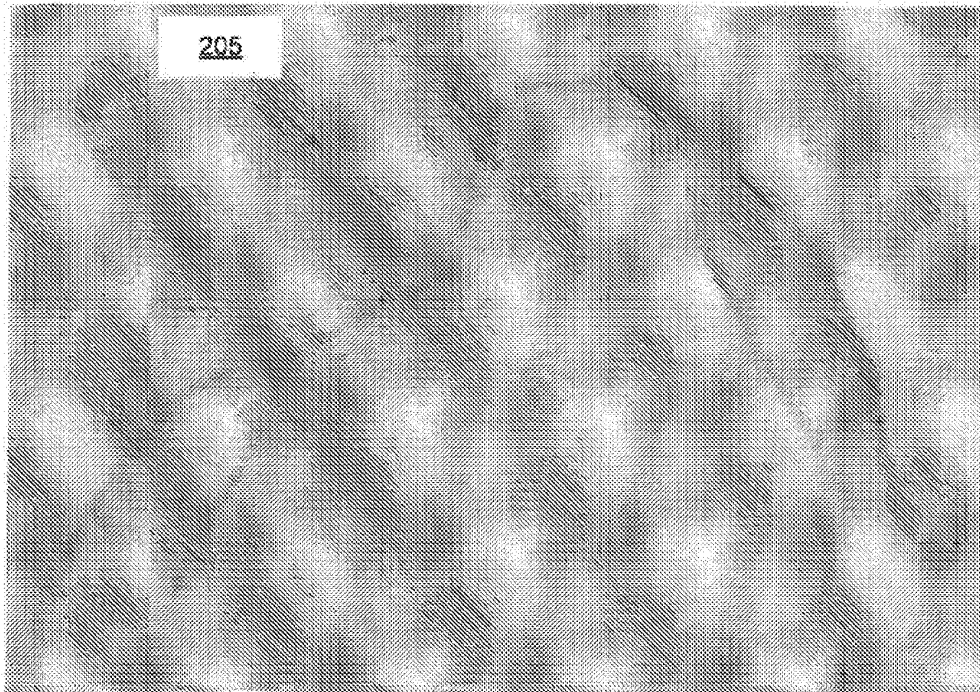

Fig. 2e)



5/28

Fig. 3a)

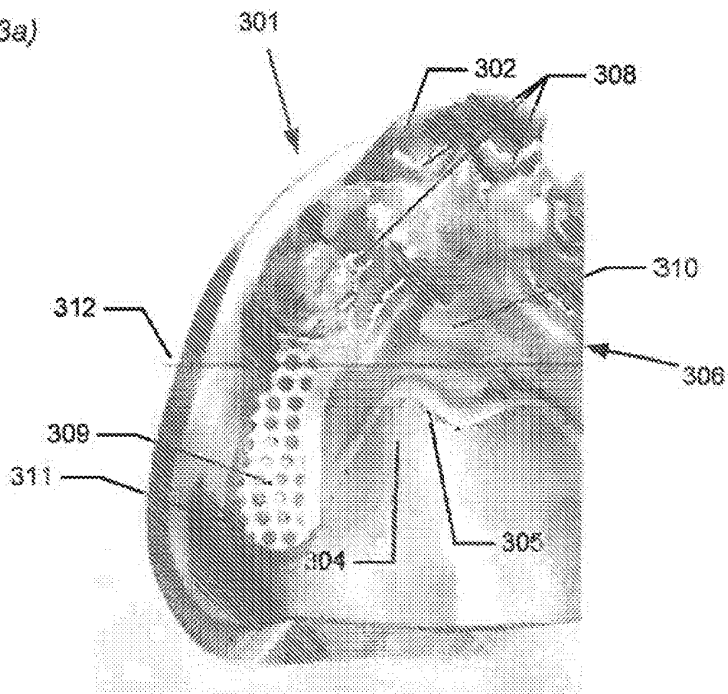

Fig. 3b)

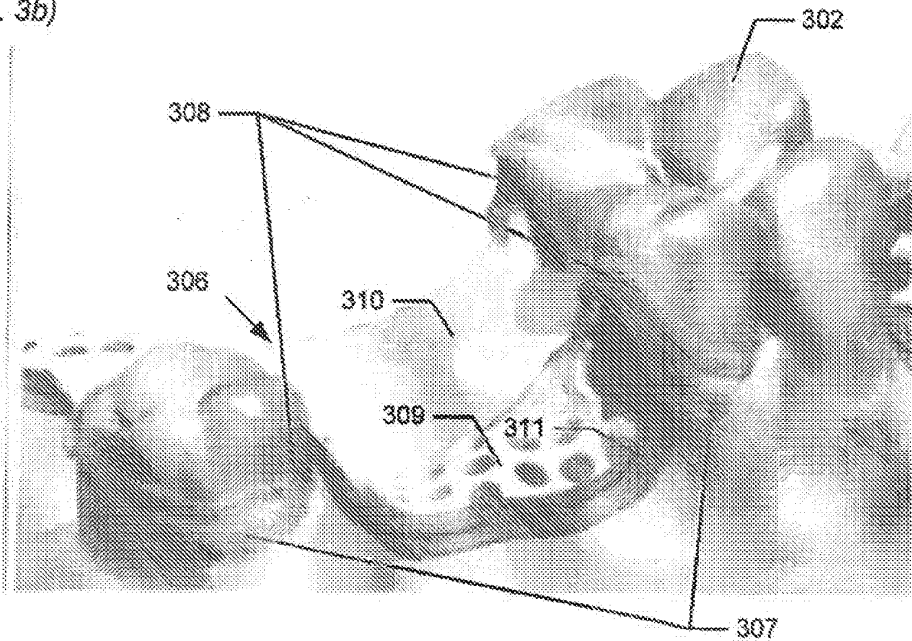
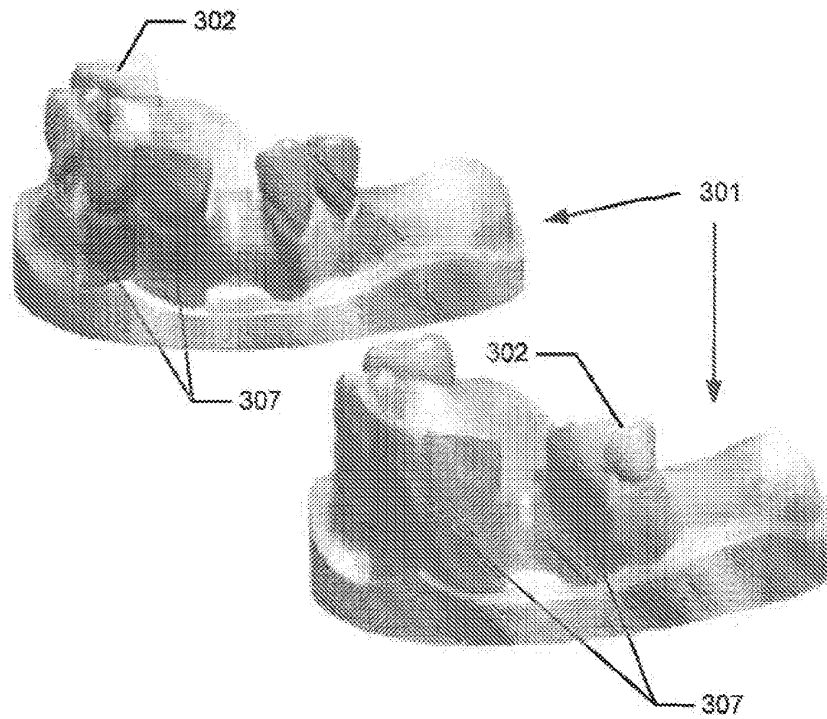

Fig. 3c)



7/28

Fig. 4a)

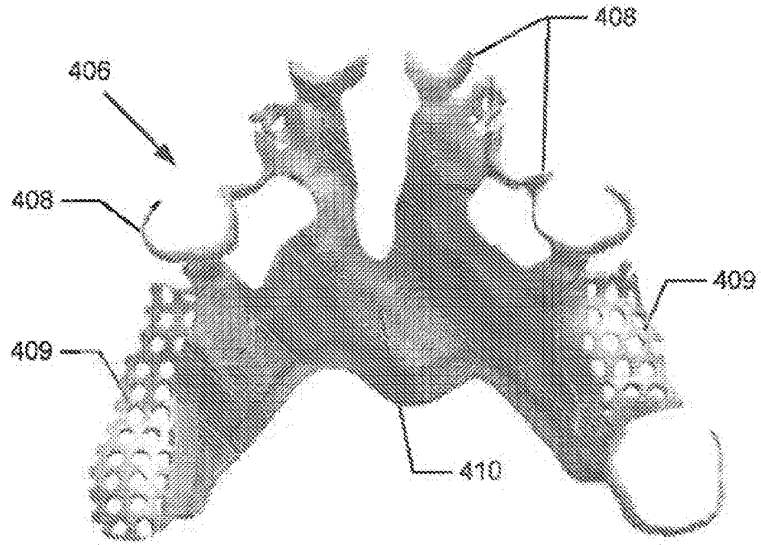
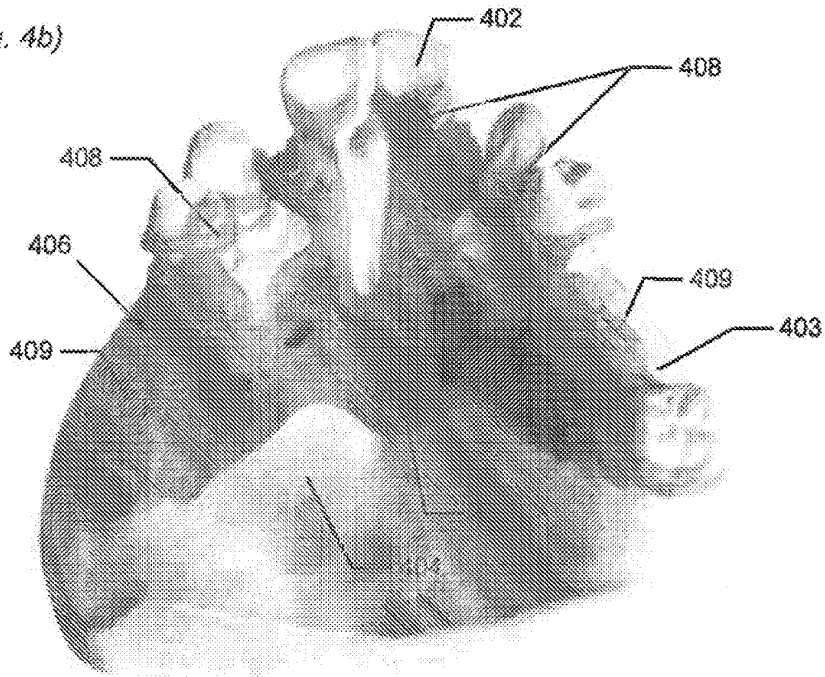

Fig. 4b)



8/28

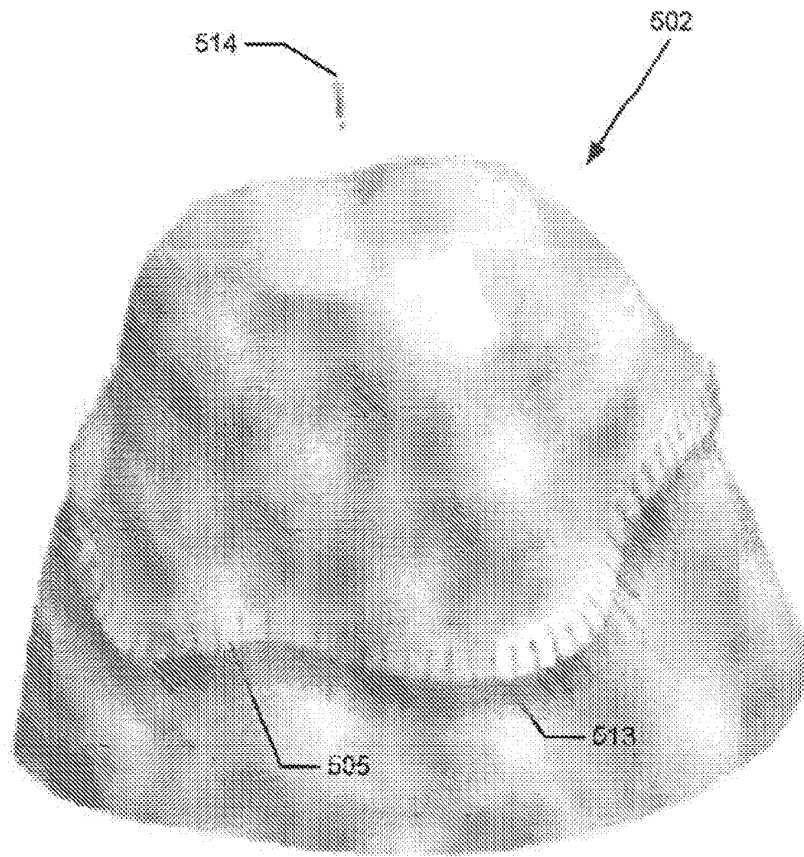

Fig. 5a)

9/28

Fig. 5b)

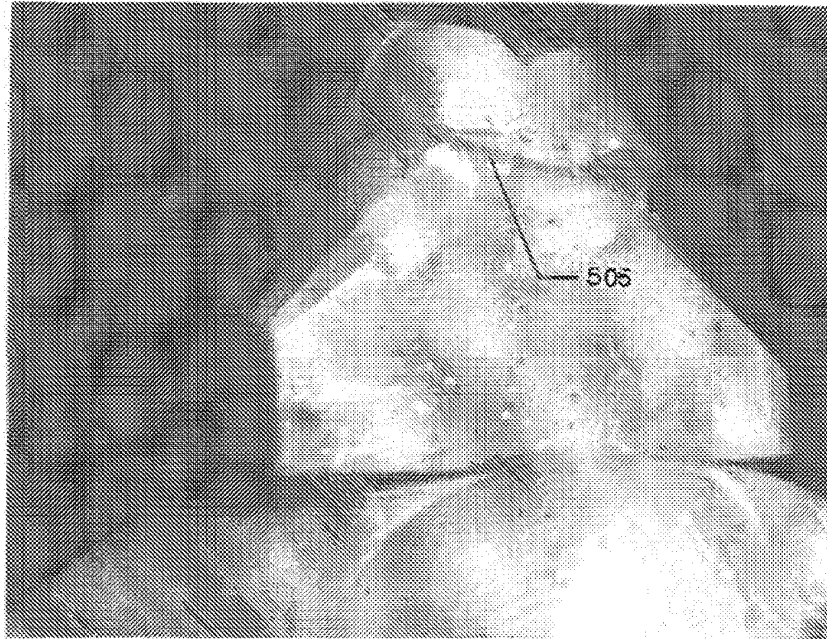
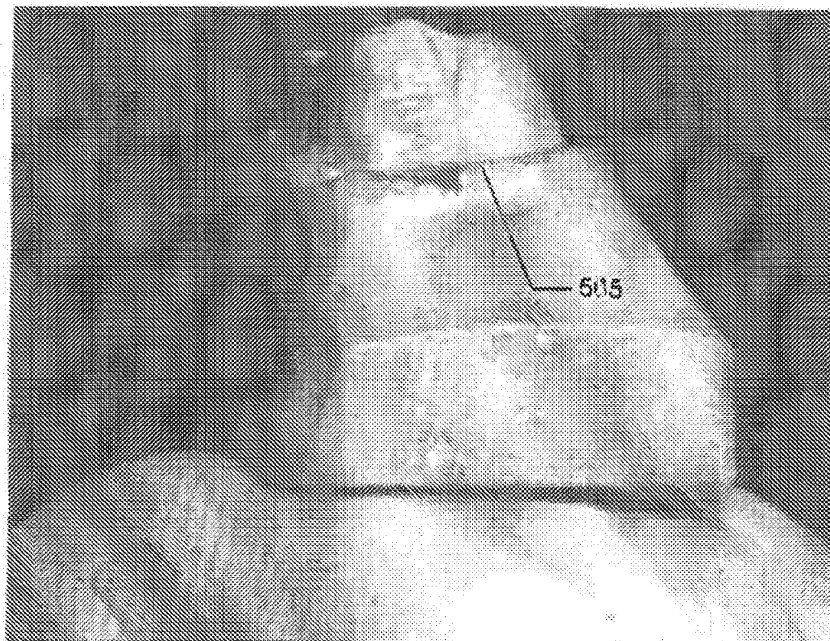

Fig. 5c)



10/28

Fig. 5d)

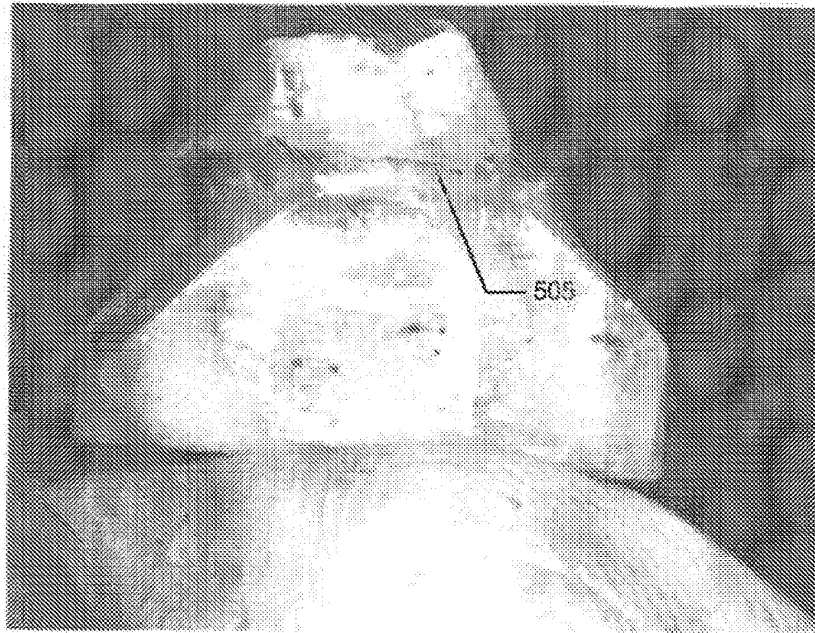

Fig. 5e)

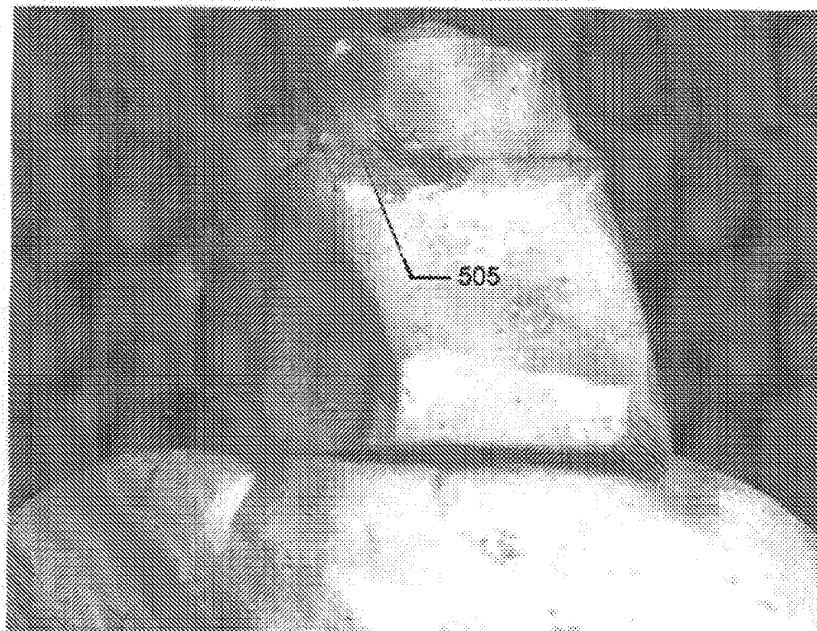

Fig. 5f)

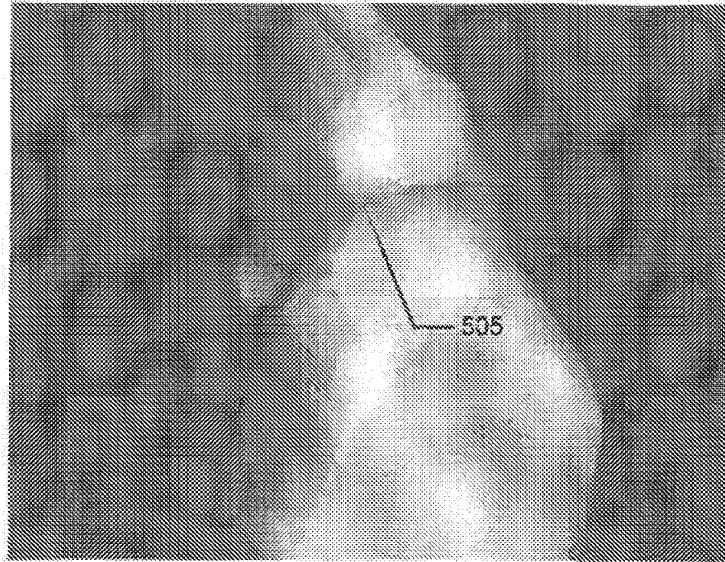
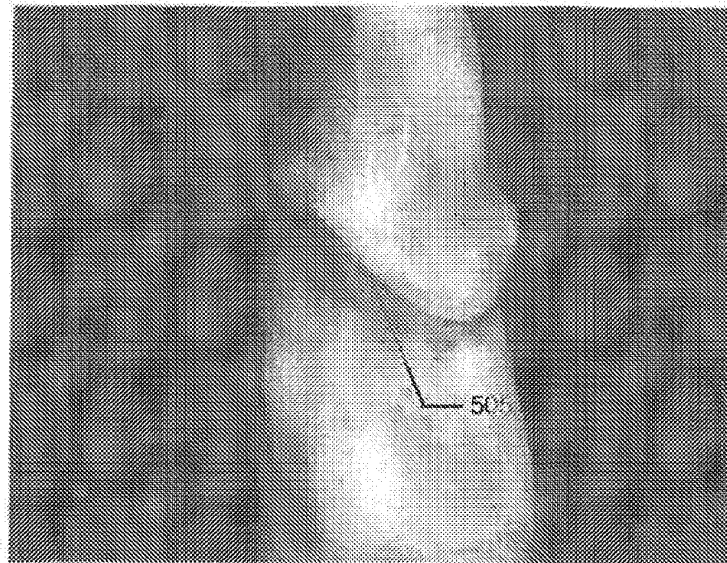

Fig. 5g)



12/28

Fig. 5h)

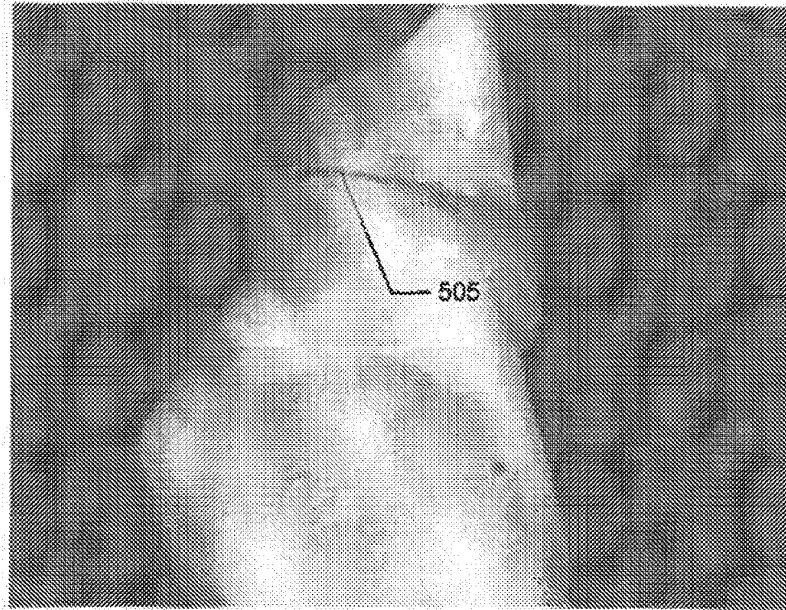

Fig. 5i)

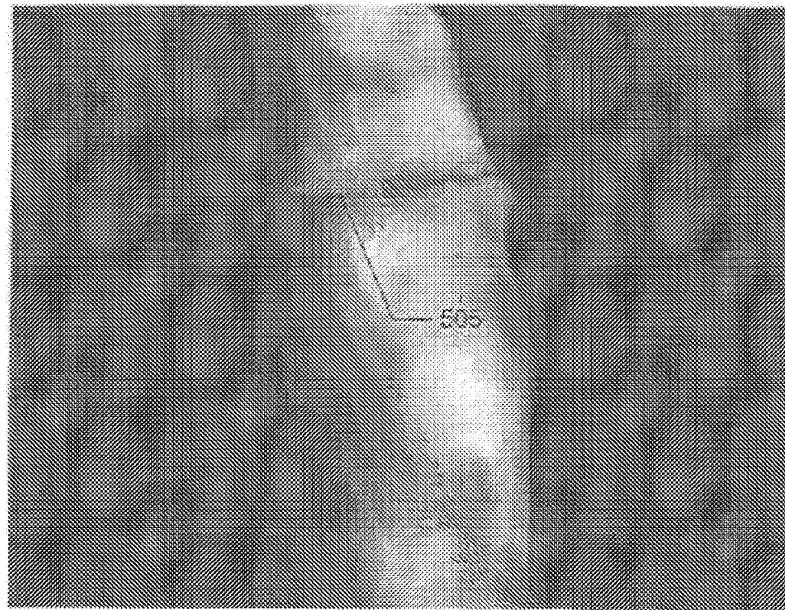

Fig. 5j)



Fig. 5k)

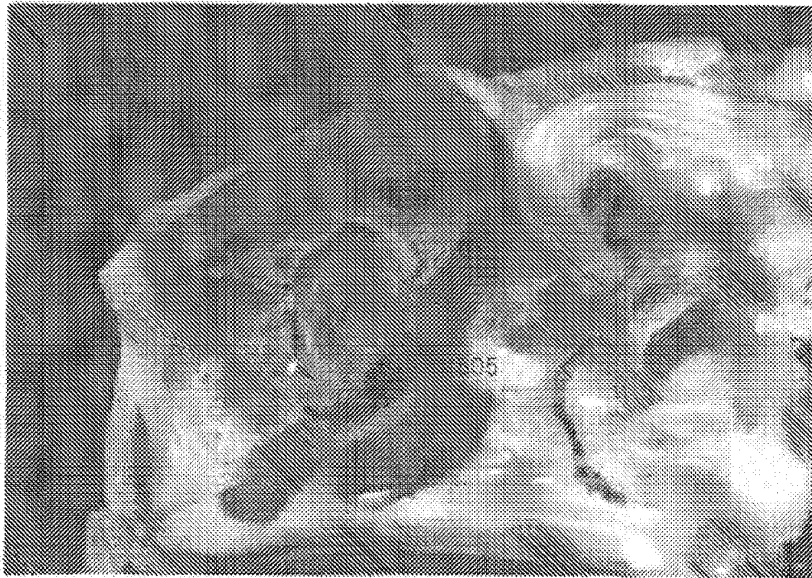

Fig. 5l)



Fig. 5m)



15/28



Fig. 6a)



Fig. 6b)

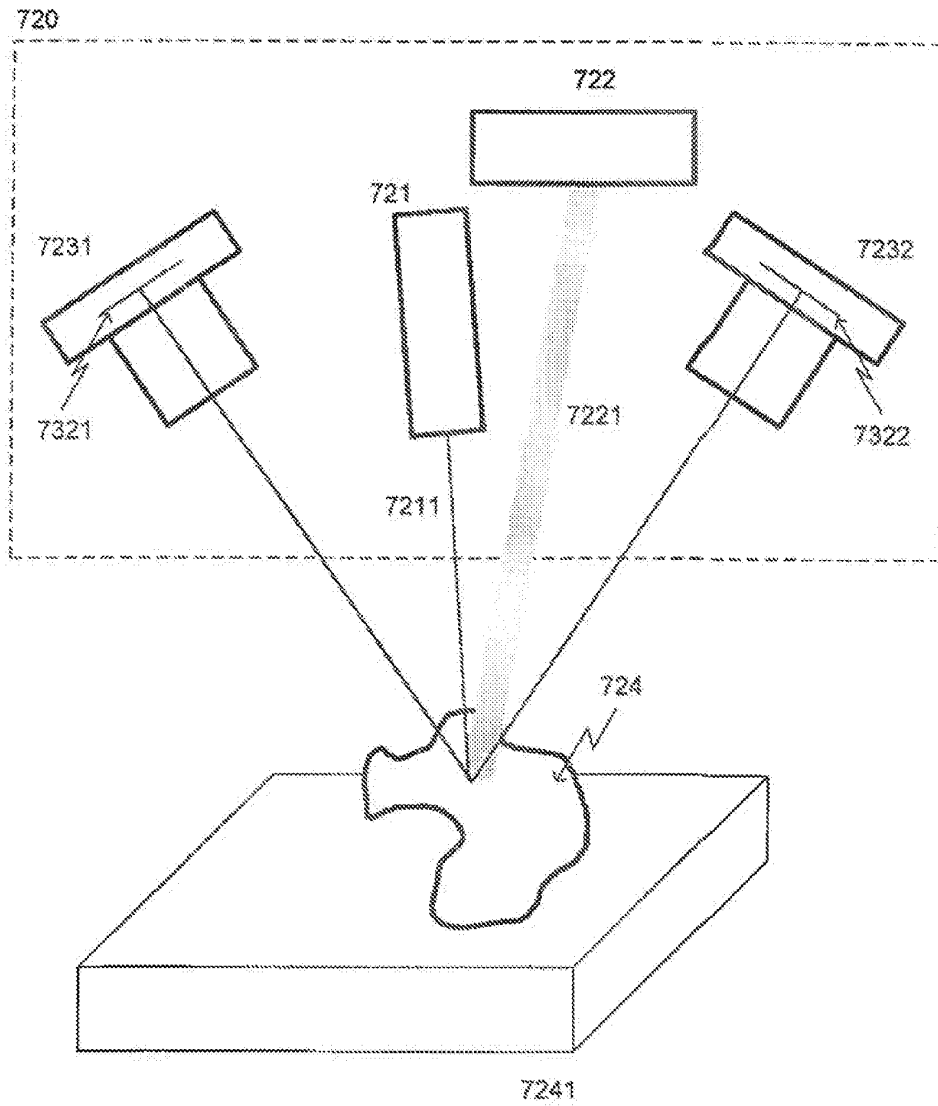

Fig. 7

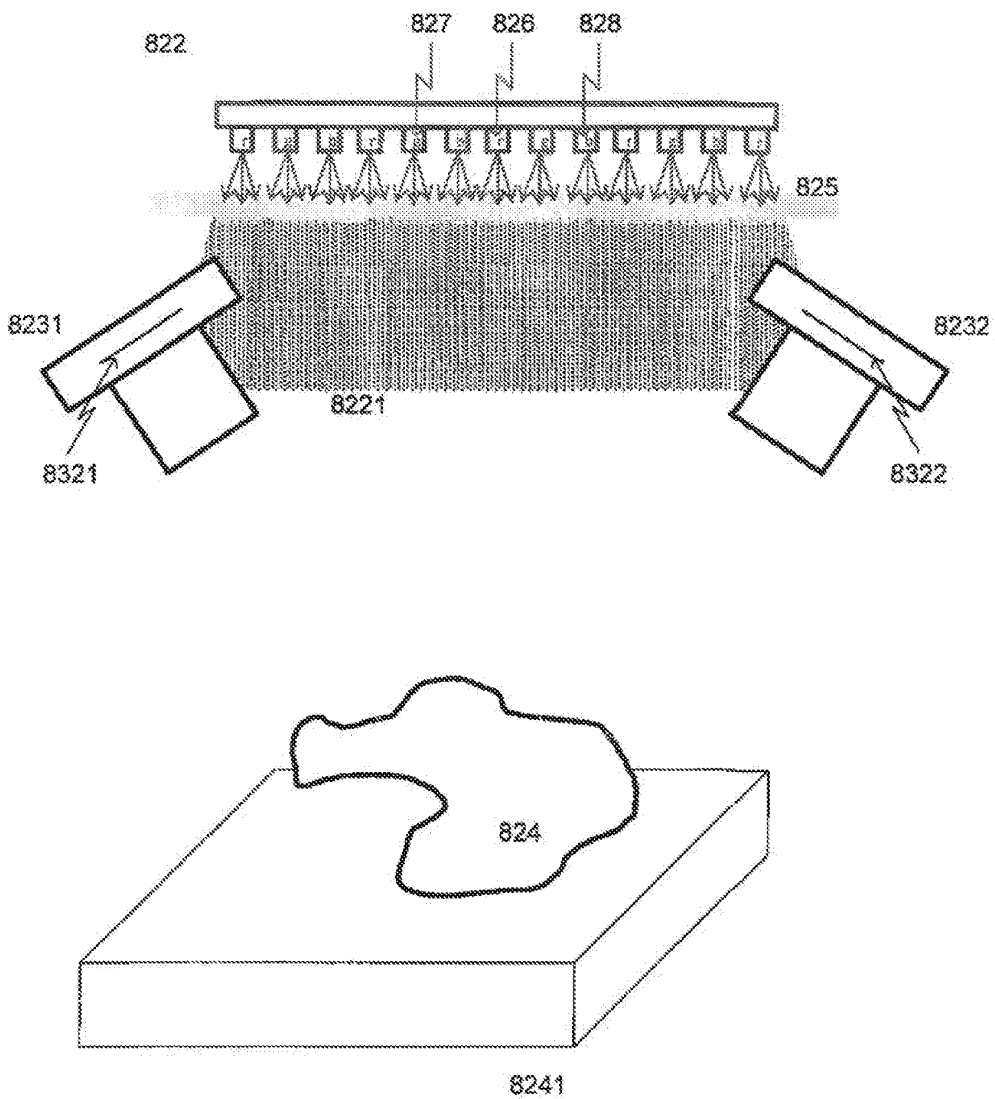

Fig. 8

19/28

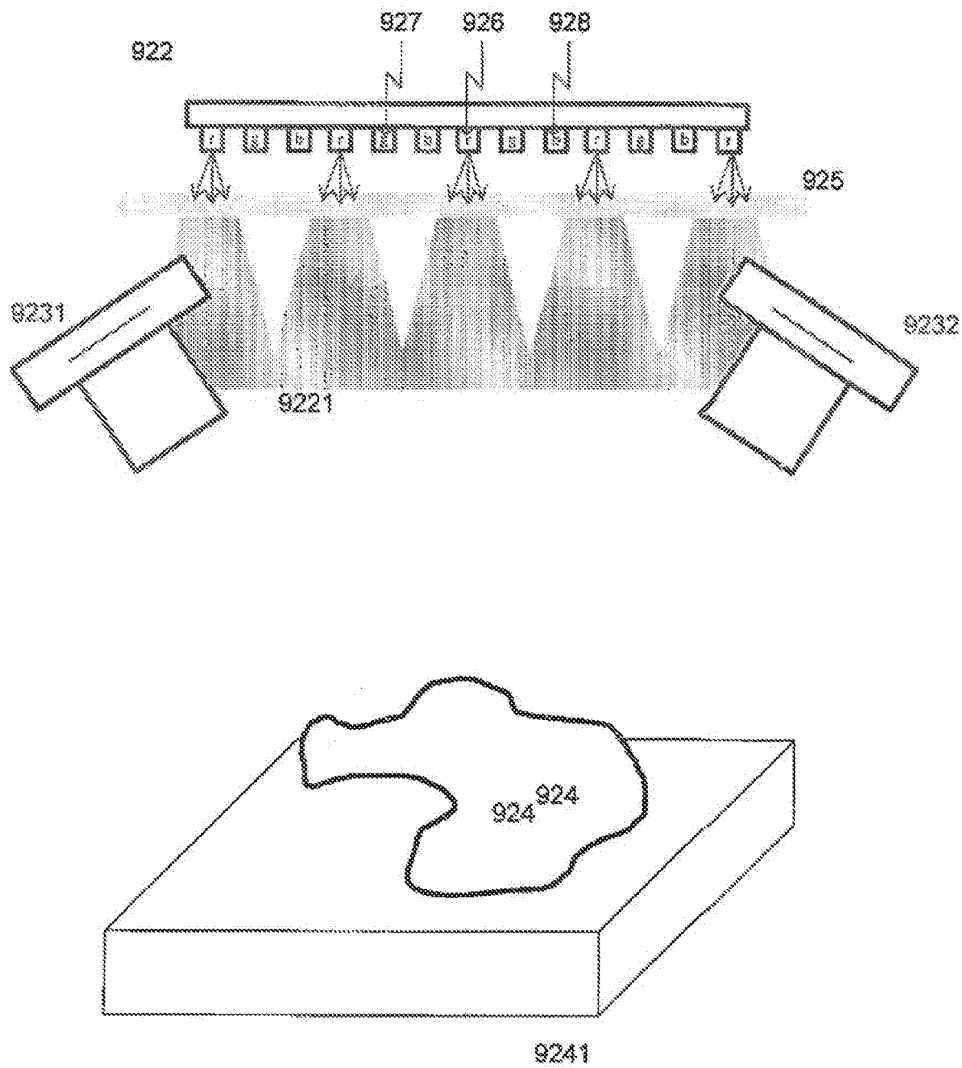

Fig. 9

20/28

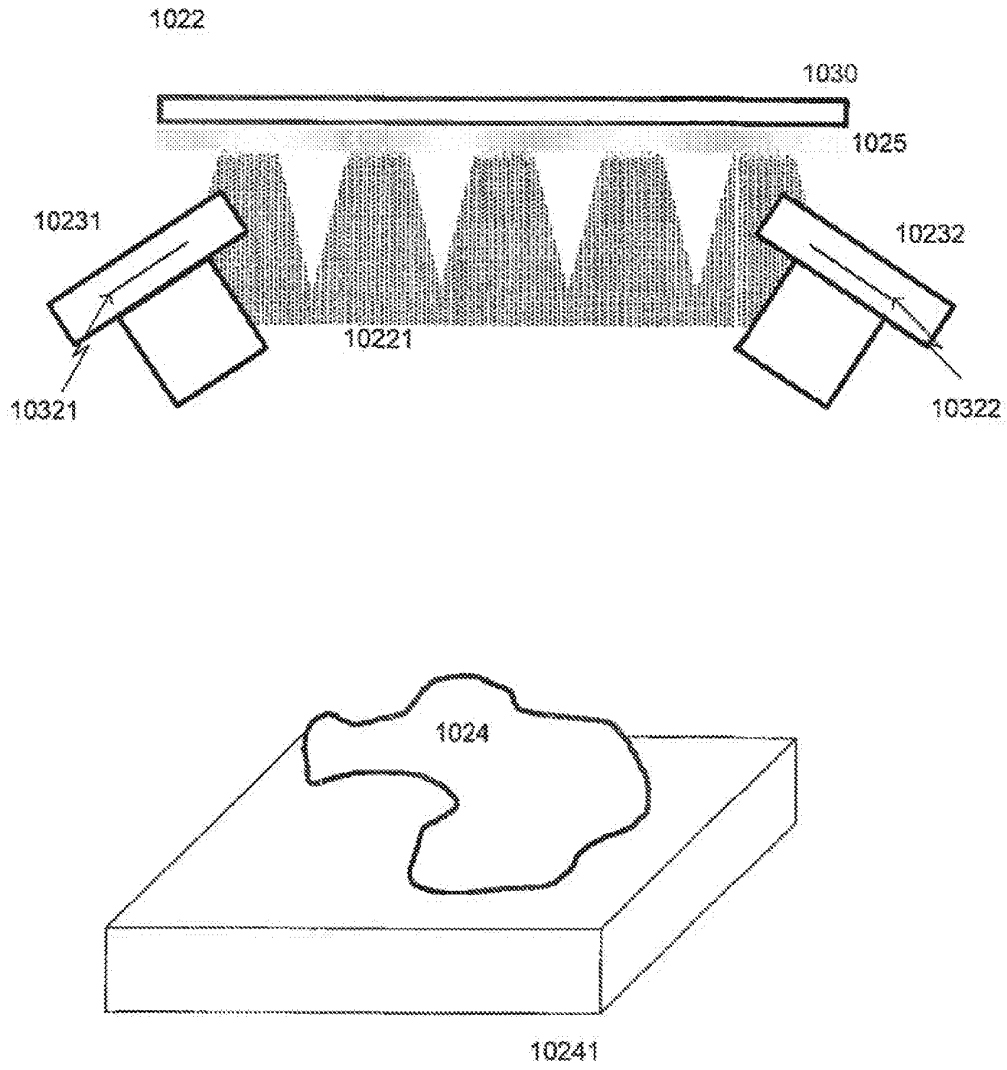

Fig. 10

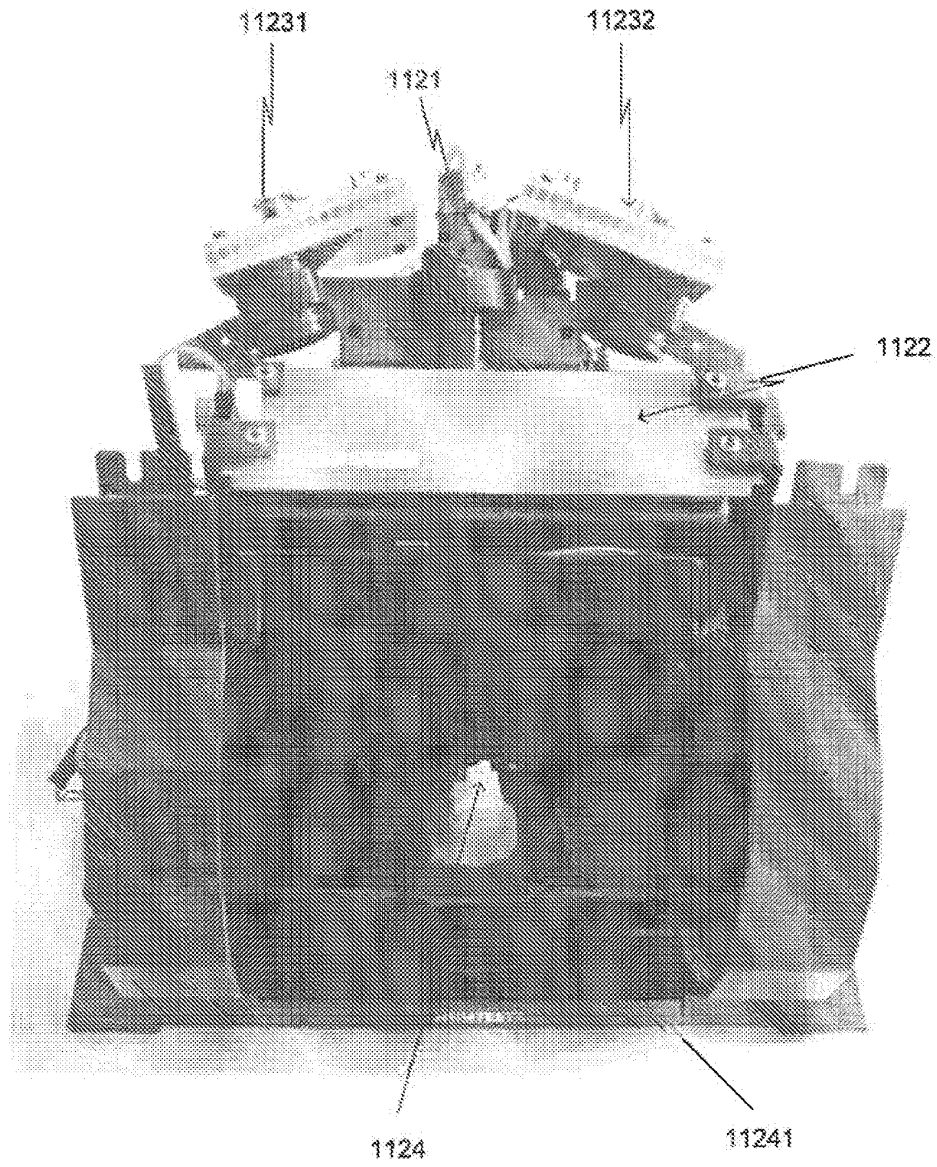

Fig. 11a

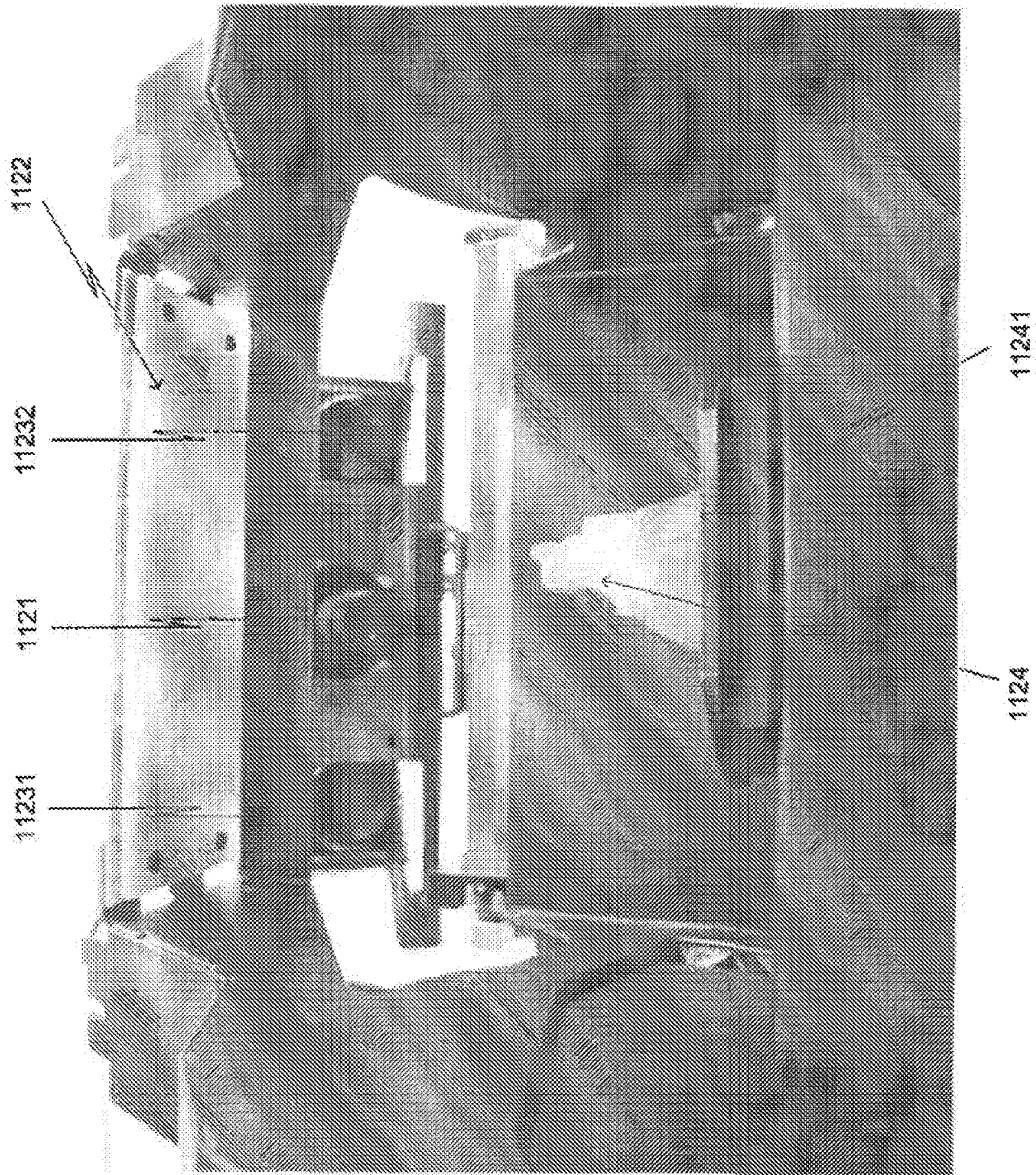

Fig. 11b

23/28

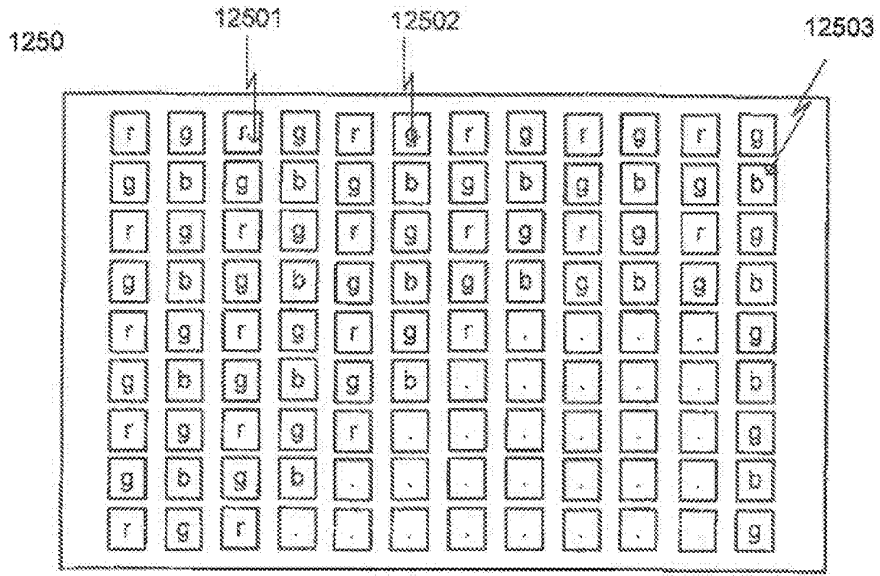

Fig. 12a

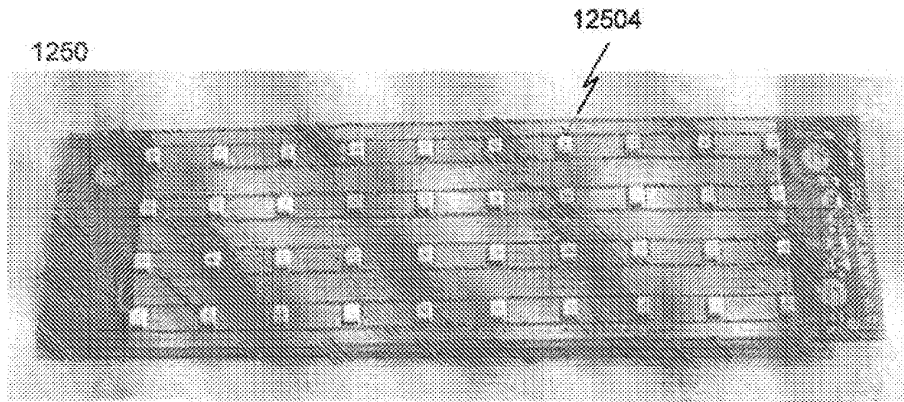
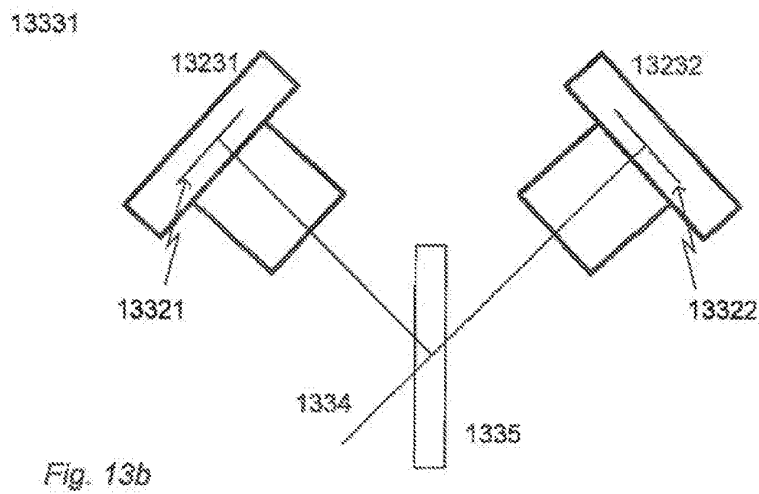
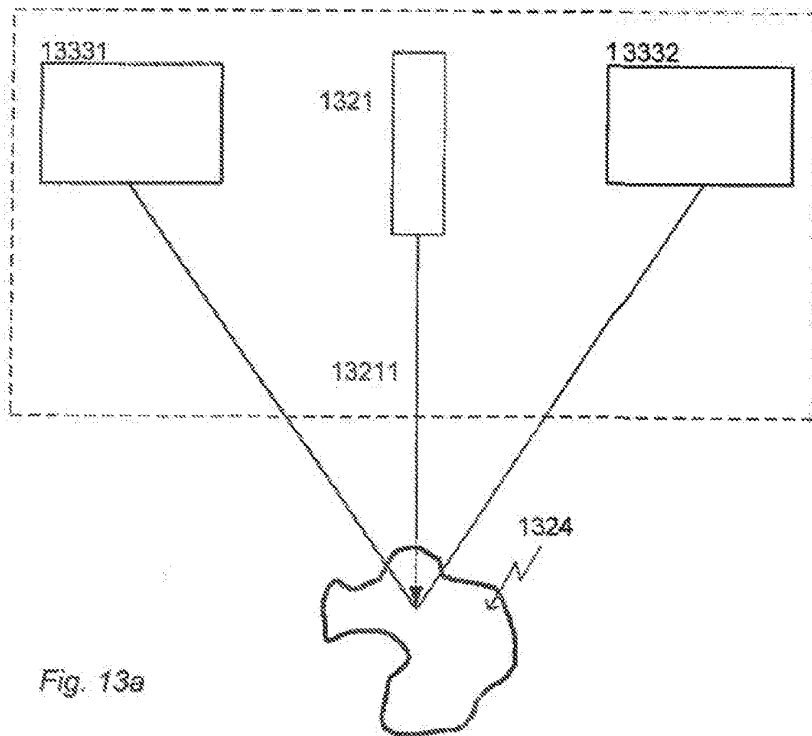

Fig. 12b



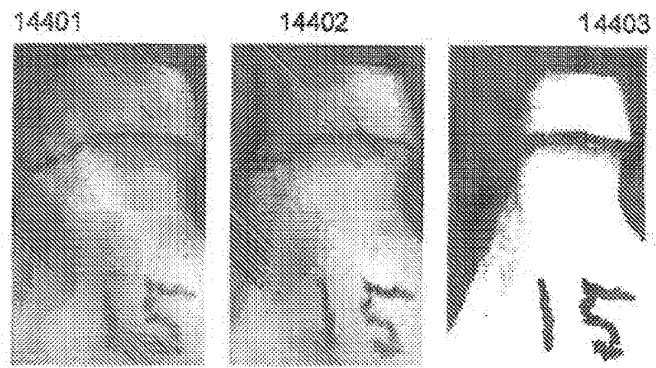

Fig. 14

1542

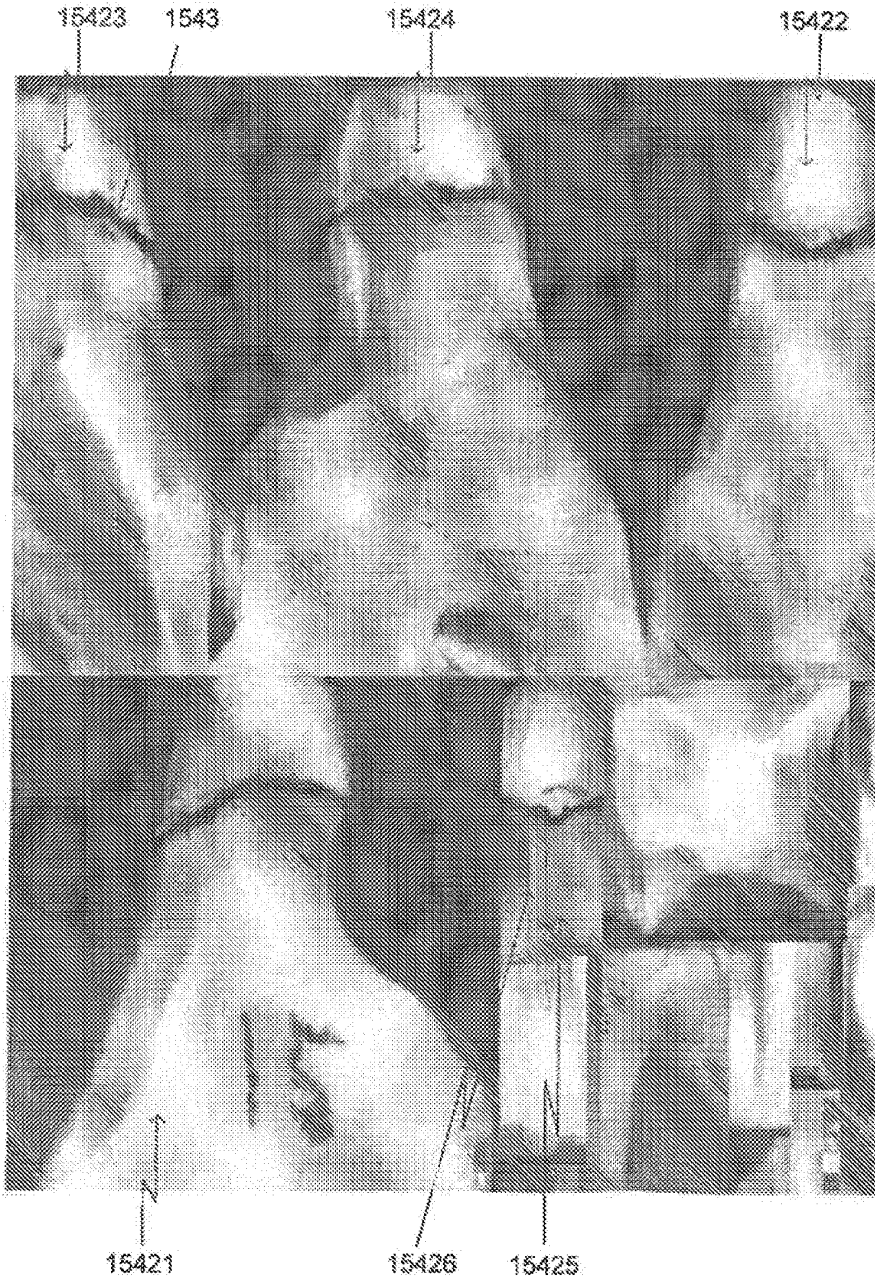

Fig. 15

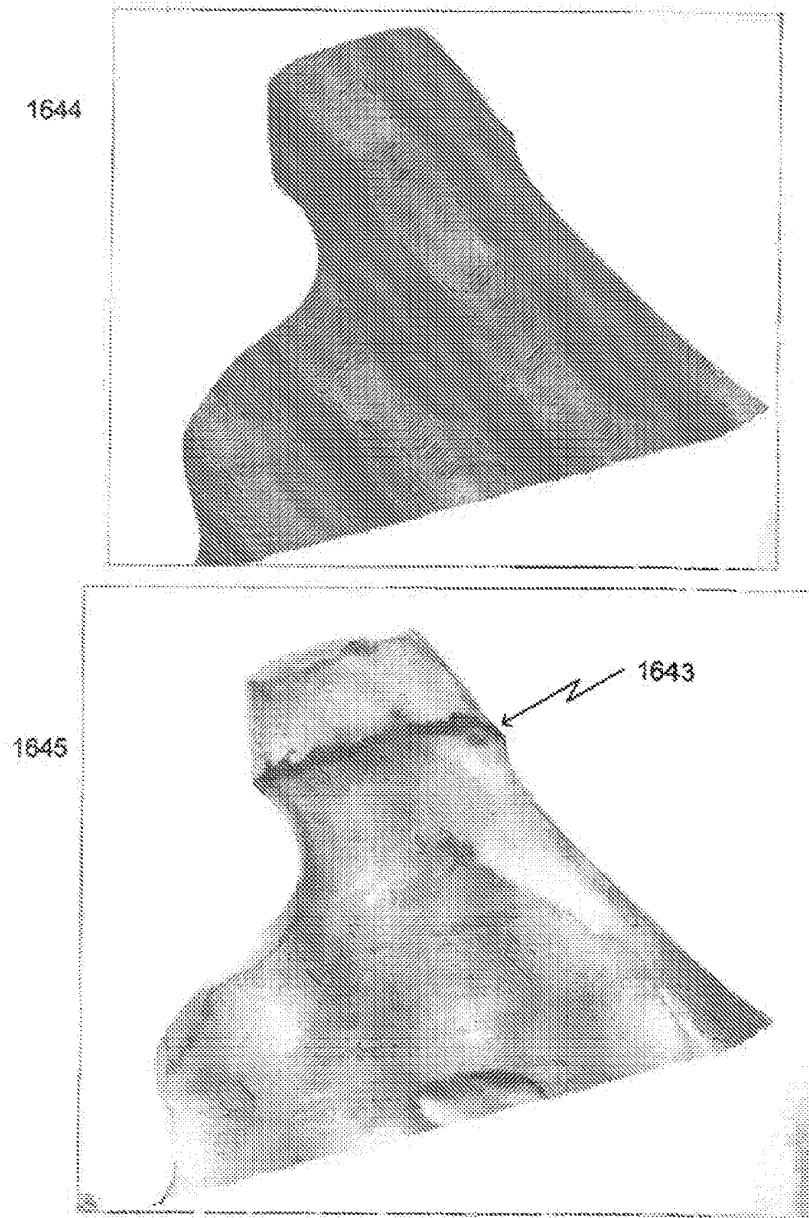

Fig. 16

1745

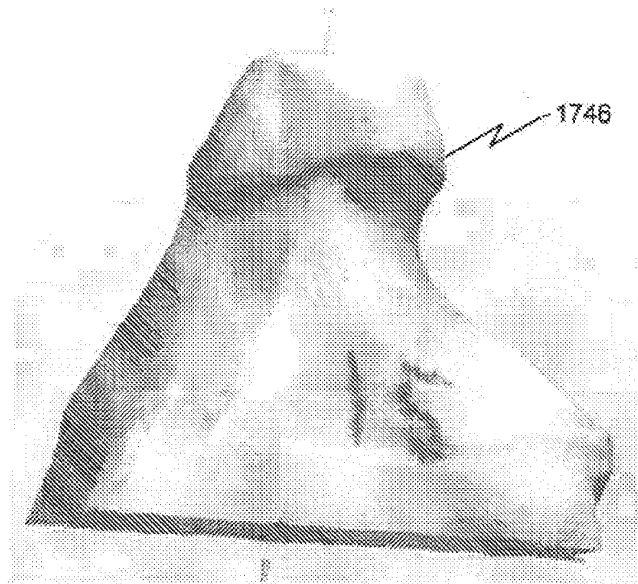

Fig. 17a

17451

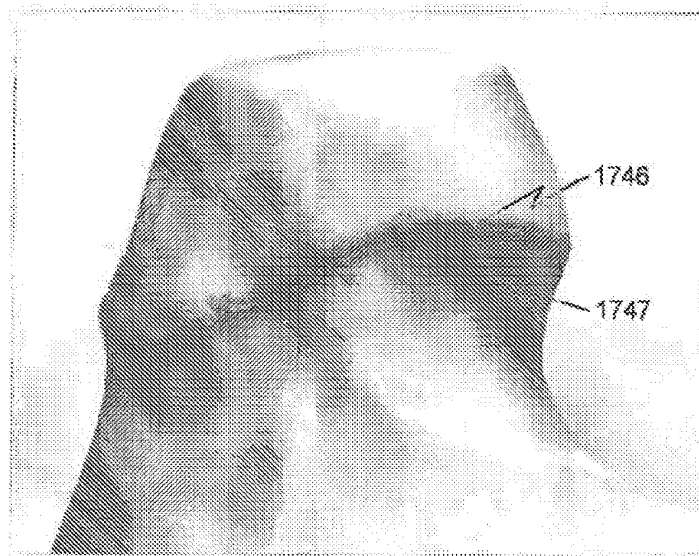

Fig. 17b

INTERNATIONAL SEARCH REPORT

International application No.

PCT/DK2011/050273

A. CLASSIFICATION OF SUBJECT MATTER A61C13/00 (2006.01)		
According to International Patent Classification (IPC) or to both national classification and IPC		
B. FIELDS SEARCHED		
Minimum documentation searched (classification system followed by classification symbols)		
IPC, ECLA: A61C		
Documentation searched other than minimum documentation to the extent that such documents are included in the fields searched		
Electronic data base consulted during the international search (name of data base and, where practicable, search terms used)		
EPODOC, WPI, TXTE		
C. DOCUMENTS CONSIDERED TO BE RELEVANT		
Category*	Citation of document, with indication, where appropriate, of the relevant passages	Relevant to claim No.
X	WO 2008/128700 A1 (MATERIALISE DENTAL N.V.) 30.10.2008, page 2 line 1-19, page 5 line 26 to page 6 line 9, page 9 line 8-20, page 18 line 2-11 and figures 1-2.	1-44, 46, 48-92, 96-98.
A		45, 47, 93-95
A	US 2009/0133260 A1 (DURBIN et al.) 28.05.2009, paragraph (0005).	1-98
A	US 2007262983 A1 (WONCHEOL) 15.11.2007, paragraph (0004) - (0005), (0051) - (0052) and figure 5.	1-98
<input type="checkbox"/> Further documents are listed in the continuation of Box C. <input checked="" type="checkbox"/> See patent family annex.		
* Special categories of cited documents:		
"A" document defining the general state of the art which is not considered to be of particular relevance	"F" later document published after the international filing date or priority date and not in conflict with the application but cited to undermend the principle or theory underlying the invention	
"E" earlier application or patent but published on or after the international filing date	"X" document of particular relevance; the claimed invention cannot be considered novel or cannot be considered to involve an inventive step when the document is taken alone	
"L" document which may throw doubts on priority claims) or which is cited to establish the publication date of another citation or other special reason (as specified)	"Y" document of particular relevance; the claimed invention cannot be considered to involve an inventive step when the document is combined with one or more other such documents, such combination being obvious to a person skilled in the art	
"O" document referring to an oral disclosure, use, exhibition or other means	"G" document member of the same patent family	
"P" document published prior to the international filing date but later than the priority date claimed		
Date of the actual completion of the international search	Date of mailing of the international search report	
07/09/2011	14/09/2011	
Name and mailing address of the ISA/ Nordic Patent Institute, Høeghshøj Allé 81, DK-2630 Taastrup, Denmark	Authorized officer	
Facsimile No.	Peter Simonsen	
	Telephone No. +45 43 50 83 25	

INTERNATIONAL SEARCH REPORT

International application No.
PCT/DK2011/050273

Box No. II Observations where certain claims were found unsearchable (Continuation of item 2 of first sheet)

This international search report has not been established in respect of certain claims under Article 17(2)(a) for the following reasons:

1. Claims Nos.:
because they relate to subject matter not required to be searched by this Authority, namely:

2. Claims Nos.:
because they relate to parts of the international application that do not comply with the prescribed requirements to such an extent that no meaningful international search can be carried out, specifically:

3. Claims Nos.:
because they are dependent claims and are not drafted in accordance with the second and third sentences of Rule 6.4(a).

Box No. III Observations where unity of invention is lacking (Continuation of item 3 of first sheet)

This International Searching Authority found multiple inventions in this international application, as follows:

1. As all required additional search fees were timely paid by the applicant, this international search report covers all searchable claims.
2. As all searchable claims could be searched without effort justifying additional fees, this Authority did not invite payment of additional fees.
3. As only some of the required additional search fees were timely paid by the applicant, this international search report covers only those claims for which fees were paid, specifically claims Nos.:

4. No required additional search fees were timely paid by the applicant. Consequently, this international search report is restricted to the invention first mentioned in the claims; it is covered by claims Nos.:

- Remark on Protest**
- The additional search fees were accompanied by the applicant's protest and, where applicable, the payment of a protest fee.
 - The additional search fees were accompanied by the applicant's protest but the applicable protest fee was not paid within the time limit specified in the invitation.
 - No protest accompanied the payment of additional search fees.

INTERNATIONAL SEARCH REPORT
Information on patent family members

International application No.
PCT/DK2011/050273

Patent document cited in search report	Publication date	Patent family member (s)	Publication date
WO 2008/128700 A1	30.10.2008	NONE	
US 2009/0133260 A1	28.05.2009	NONE	
US 2007262983 A1	15.11.2007	WO2007134129 A2 WO2007134129 A3 JP2009536859 A EP2024907 A2	20071122 20081016 20091022 20090218

Electronic Acknowledgement Receipt

EFS ID:	26757402
Application Number:	14764087
International Application Number:	
Confirmation Number:	6247
Title of Invention:	FOCUS SCANNING APPARATUS RECORDING COLOR
First Named Inventor/Applicant Name:	Bo ESBECH
Customer Number:	21839
Filer:	William C. Rowland/Mich Sok
Filer Authorized By:	William C. Rowland
Attorney Docket Number:	00791 24-000111
Receipt Date:	26-AUG-2016
Filing Date:	28-JUL-2015
Time Stamp:	11:33:21
Application Type:	U.S. National Stage under 35 USC 371

Payment information:

Submitted with Payment	no
------------------------	----

File Listing:

Document Number	Document Description	File Name	File Size(Bytes)/ Message Digest	Multi Part /.zip	Pages (if appl.)
1	Information Disclosure Statement (IDS) Form (SB08)	PTO_SB08.pdf	612812 a22ef2d8339ea032368401d4b5bbfe79d866b1e1	no	5

Warnings:

Information:					
2	Foreign Reference	CN102008282.pdf	1240502 d7f3ce35a1bdd35c02bcc8db836644b8eed d9e23	no	7
Warnings:					
Information:					
3	Foreign Reference	CN102112845.pdf	6268685 0f4c7900d5485620f5afcf4524db48x44873 417f	no	28
Warnings:					
Information:					
4	Foreign Reference	CN102402799.pdf	2550087 1185e6c8055b69ad7dd628aa86c57d866a 5215e	no	16
Warnings:					
Information:					
5	Foreign Reference	CN102802520.pdf	11027033 1af1166714d2af5688d54200dea5b10b64b 66bcc	no	57
Warnings:					
Information:					
6	Foreign Reference	WO2012007003.pdf	23332481 4311bcfa02dcfd20910cc6042d86b797d70 db9f3	no	133
Warnings:					
Information:					
7	Other Reference-Patent/App/Search documents	CNOA08022016.pdf	4174800 b361264305e750c20e03d7d1c46328777b d8755d	no	18
Warnings:					
Information:					
8	Other Reference-Patent/App/Search documents	CN_SEARCH07252016.pdf	247418 1d3573953abda2e46ca5e4a6dd2eb28b92 cf2c12	no	2
Warnings:					
Information:					
Total Files Size (in bytes):				49453818	

This Acknowledgement Receipt evidences receipt on the noted date by the USPTO of the indicated documents, characterized by the applicant, and including page counts, where applicable. It serves as evidence of receipt similar to a Post Card, as described in MPEP 503.

New Applications Under 35 U.S.C. 111

If a new application is being filed and the application includes the necessary components for a filing date (see 37 CFR 1.53(b)-(d) and MPEP 506), a Filing Receipt (37 CFR 1.54) will be issued in due course and the date shown on this Acknowledgement Receipt will establish the filing date of the application.

National Stage of an International Application under 35 U.S.C. 371

If a timely submission to enter the national stage of an international application is compliant with the conditions of 35 U.S.C. 371 and other applicable requirements a Form PCT/DO/EO/903 indicating acceptance of the application as a national stage submission under 35 U.S.C. 371 will be issued in addition to the Filing Receipt, in due course.

New International Application Filed with the USPTO as a Receiving Office

If a new international application is being filed and the international application includes the necessary components for an international filing date (see PCT Article 11 and MPEP 1810), a Notification of the International Application Number and of the International Filing Date (Form PCT/RO/105) will be issued in due course, subject to prescriptions concerning national security, and the date shown on this Acknowledgement Receipt will establish the international filing date of the application.



UNITED STATES PATENT AND TRADEMARK OFFICE

UNITED STATES DEPARTMENT OF COMMERCE
United States Patent and Trademark Office
Address: COMMISSIONER FOR PATENTS
P.O. Box 1450
Alexandria, Virginia 22313-1450
www.uspto.gov

Table with 5 columns: APPLICATION NO., FILING DATE, FIRST NAMED INVENTOR, ATTORNEY DOCKET NO., CONFIRMATION NO. Includes sub-tables for EXAMINER, ART UNIT, PAPER NUMBER, NOTIFICATION DATE, and DELIVERY MODE.

Please find below and/or attached an Office communication concerning this application or proceeding.

The time period for reply, if any, is set in the attached communication.

Notice of the Office communication was sent electronically on above-indicated "Notification Date" to the following e-mail address(es):

ADIPDOC1@BIPC.com

Office Action Summary	Application No. 14/764,087	Applicant(s) ESBECH ET AL.	
	Examiner KEVIN PYO	Art Unit 2878	AIA (First Inventor to File) Status No

-- The MAILING DATE of this communication appears on the cover sheet with the correspondence address --

Period for Reply

A SHORTENED STATUTORY PERIOD FOR REPLY IS SET TO EXPIRE 3 MONTHS FROM THE MAILING DATE OF THIS COMMUNICATION.

- Extensions of time may be available under the provisions of 37 CFR 1.136(a). In no event, however, may a reply be timely filed after SIX (6) MONTHS from the mailing date of this communication.
- If NO period for reply is specified above, the maximum statutory period will apply and will expire SIX (6) MONTHS from the mailing date of this communication.
- Failure to reply within the set or extended period for reply will, by statute, cause the application to become ABANDONED (35 U.S.C. § 133). Any reply received by the Office later than three months after the mailing date of this communication, even if timely filed, may reduce any earned patent term adjustment. See 37 CFR 1.704(b).

Status

- 1) Responsive to communication(s) filed on 7/28/2015.
 A declaration(s)/affidavit(s) under **37 CFR 1.130(b)** was/were filed on _____.
- 2a) This action is **FINAL**. 2b) This action is non-final.
- 3) An election was made by the applicant in response to a restriction requirement set forth during the interview on _____; the restriction requirement and election have been incorporated into this action.
- 4) Since this application is in condition for allowance except for formal matters, prosecution as to the merits is closed in accordance with the practice under *Ex parte Quayle*, 1935 C.D. 11, 453 O.G. 213.

Disposition of Claims*

- 5) Claim(s) 1-31 is/are pending in the application.
5a) Of the above claim(s) _____ is/are withdrawn from consideration.
- 6) Claim(s) _____ is/are allowed.
- 7) Claim(s) 1-11, 13 and 17-30 is/are rejected.
- 8) Claim(s) 12, 14-16 and 31 is/are objected to.
- 9) Claim(s) _____ are subject to restriction and/or election requirement.

* If any claims have been determined allowable, you may be eligible to benefit from the **Patent Prosecution Highway** program at a participating intellectual property office for the corresponding application. For more information, please see http://www.uspto.gov/patents/init_events/pph/index.jsp or send an inquiry to PPHfeedback@uspto.gov.

Application Papers

- 10) The specification is objected to by the Examiner.
- 11) The drawing(s) filed on _____ is/are: a) accepted or b) objected to by the Examiner.
Applicant may not request that any objection to the drawing(s) be held in abeyance. See 37 CFR 1.85(a).
Replacement drawing sheet(s) including the correction is required if the drawing(s) is objected to. See 37 CFR 1.121(d).

Priority under 35 U.S.C. § 119

- 12) Acknowledgment is made of a claim for foreign priority under 35 U.S.C. § 119(a)-(d) or (f).

Certified copies:

- a) All b) Some** c) None of the:
1. Certified copies of the priority documents have been received.
2. Certified copies of the priority documents have been received in Application No. _____.
3. Copies of the certified copies of the priority documents have been received in this National Stage application from the International Bureau (PCT Rule 17.2(a)).

** See the attached detailed Office action for a list of the certified copies not received.

Attachment(s)

- 1) Notice of References Cited (PTO-892)
- 2) Information Disclosure Statement(s) (PTO/SB/08a and/or PTO/SB/08b)
Paper No(s)/Mail Date 7/28/2015; 8/26/2016
- 3) Interview Summary (PTO-413)
Paper No(s)/Mail Date. _____.
- 4) Other: _____.

1. The present application is being examined under the pre-AIA first to invent provisions.

Claim Rejections - 35 USC § 112

2. Claims 11, 17, 20, 22-24 and 29 are rejected under 35 U.S.C. 112(b) or 35 U.S.C. 112 (pre-AIA), second paragraph, as being indefinite for failing to particularly point out and distinctly claim the subject matter which the inventor or a joint inventor, or for pre-AIA the applicant regards as the invention.

Regarding claim 11, the phrase “such as” renders the claim indefinite because it is unclear whether the limitations following the phrase are part of the claimed invention. The resulting claim does not clearly set forth the metes and bounds of the patent protection desired.

Regarding claim 17, it is unclear what is meant by the phrase “comparing the derived surface color information of sections of the captured 2D images **and/or** of the generating sub-scans of the object” (emphasis added) due to the confusing nature of wordings therein. It is unclear what exactly are being compared due to the use of alternative language.

Regarding claim 20, the phrase “the color filter array” of line 2 lacks a proper antecedent basis.

Regarding claim 22, the phrase “the color filter array” of line 2 lacks a proper antecedent basis.

Regarding claim 24, the phrase “the pattern generating element” of line 2 lacks a proper antecedent basis.

Regarding claim 29, the phrase “the color filter array” of line 1 lacks a proper antecedent basis.

Claims not specifically mentioned above are rejected by virtue of their dependency on a rejected claim.

Claim Rejections - 35 USC § 102

3. The following is a quotation of the appropriate paragraphs of pre-AIA 35 U.S.C. 102 that form the basis for the rejections under this section made in this Office action:

A person shall be entitled to a patent unless –

(e) the invention was described in (1) an application for patent, published under section 122(b), by another filed in the United States before the invention by the applicant for patent or (2) a patent granted on an application for patent by another filed in the United States before the invention by the applicant for patent, except that an international application filed under the treaty defined in section 351(a) shall have the effects for purposes of this subsection of an application filed in the United States only if the international application designated the United States and was published under Article 21(2) of such treaty in the English language.

4. Claim(s) 1-4, 13, 17, 19, 25, 26 and 27 is/are rejected under pre-AIA 35 U.S.C. 102(e) as being anticipated by Colonna de Lega (US 2012/0140243; hereinafter Colonna).

Regarding claim 1, Colonna shows in Fig.1 the following elements of applicant's claim: a multichromatic light source (paragraph 60) configured for providing a multichromatic probe light for illumination of the object; a color image sensor (paragraphs 25, 61, 107) comprising an array of image sensor pixels for capturing one or more 2D images of light received from said object; wherein the focus scanner is configured to operate by translating a focus plane along an optical axis of the focus scanner and capturing a series of the 2D images, each 2D image of the series is at a different focus plane position such that the series of captured 2D images forms a stack of 2D images (paragraphs 4, 57-58); and a data processing system (122) configured to derive surface geometry information for a block of said image sensor pixels from the 2D images in the stack of 2D images captured by said color image sensor, the data processing system also

Art Unit: 2878

configured to derive surface color information for the block of said image sensor pixels from at least one of the 2D images used to derive the surface geometry information (paragraphs 4, 107).

Regarding claims 2-3, the limitations therein are disclosed in paragraphs 4 and 107 of Colonna.

Regarding claim 4, Colonna discloses the use of a pattern generating element (106).

Regarding claim 13, the limitations therein are disclosed in paragraphs 58 and 107 of Colonna.

Regarding claim 17, as far as the claim is understood, the limitation therein is disclosed in paragraph 107 of Colonna.

Regarding claim 19, the limitation therein is disclosed in paragraphs 107-108 of Colonna.

Regarding claim 25, Colonna shows in Fig.1 the following elements of applicant's claim: a multichromatic light source (paragraph 60) configured for providing a multichromatic probe light; and a color image sensor (paragraphs 25, 61, 107) comprising an array of image sensor pixels for capturing one or more 2D images of light received from said object, where at least for a block of said image sensor pixels, both surface color information and surface geometry information of a part of the object are derived at least partly from one 2D image captured by said color image sensor (paragraphs 4, 107).

Regarding claim 26, the methods steps therein are inherently disclosed by Colonna.

Regarding claim 27, the limitation therein is disclosed in paragraph 57 of Colonna.

Art Unit: 2878

5. Claim(s) 1-11, 13, 17-19, 21, 25-28 and 30 is/are rejected under pre-AIA 35 U.S.C. 102(e) as being anticipated by Fisker et al (US 2012/0092461).

Regarding claim 1, Fisker et al shows in Fig.1 the following elements of applicant's claim: a multichromatic light source (110; paragraph 151) configured for providing a multichromatic probe light for illumination of the object; a color image sensor (180; paragraph 152) comprising an array of image sensor pixels for capturing one or more 2D images of light received from said object; wherein the focus scanner is configured to operate by translating a focus plane along an optical axis of the focus scanner (paragraph 30) and capturing a series of the 2D images, each 2D image of the series is at a different focus plane position such that the series of captured 2D images forms a stack of 2D images (paragraphs 194, 246); and a data processing system (paragraphs 10, 151) configured to derive surface geometry information for a block of said image sensor pixels from the 2D images in the stack of 2D images captured by said color image sensor, the data processing system also configured to derive surface color information for the block of said image sensor pixels from at least one of the 2D images used to derive the surface geometry information.

Regarding claims 2-3, the limitations therein are disclosed in paragraphs 10 and 151 of Fisker.

Regarding claim 4, Fisker discloses the use of a pattern generating element (130).

Regarding claim 5, the limitation therein is disclosed in paragraph 10 of Fisker.

Regarding claims 6-8, the limitations therein are disclosed in paragraphs 92, 114, 253-254 of Fisker.

Regarding claims 9-11 and 30, the limitations therein are disclosed in 157-158 of Fisker.

Art Unit: 2878

Regarding claim 13, the limitation therein is disclosed in paragraphs 151 and 157 of Fisker.

Regarding claim 17, as far as the claim is understood, the limitation therein is disclosed in paragraph 157 of Fisker.

Regarding claim 18, the limitation therein is disclosed in paragraph 154 of Fisker.

Regarding claims 19 and 21, the limitations therein are disclosed in paragraphs 155 and 157 of Fisker.

Regarding claim 25, Fisker shows in Fig.1 the following elements of applicant's claim: a multichromatic light source (110; paragraph 151) configured for providing a multichromatic probe light; and a color image sensor (180; paragraph 152) comprising an array of image sensor pixels for capturing one or more 2D images of light received from said object, where at least for a block of said image sensor pixels, both surface color information and surface geometry information of a part of the object are derived at least partly from one 2D image captured by said color image sensor (paragraphs 10, 151).

Regarding claim 26, the methods steps therein are inherently disclosed by Fisker.

Regarding claims 27-28, the limitations therein are shown in Fig.1 of Fisker.

Claim Rejections - 35 USC § 103

6. The following is a quotation of pre-AIA 35 U.S.C. 103(a) which forms the basis for all obviousness rejections set forth in this Office action:

(a) A patent may not be obtained though the invention is not identically disclosed or described as set forth in section 102, if the differences between the subject matter sought to be patented and the prior art are such that the subject matter as a whole would have been obvious at the time the invention was made to a person having ordinary skill in the art to which said subject matter pertains. Patentability shall not be negated by the manner in which the invention was made.

7. Claims 21 and 28 is/are rejected under pre-AIA 35 U.S.C. 103(a) as being unpatentable over Colonna de Lega.

Regarding claims 21 and 28, the specific scheme and configuration utilized would have been obvious to one of ordinary skill in the art in view of meeting different design requirements and achieving the particular desired performance.

Allowable Subject Matter

8. Claims 12, 14-16 and 31 are objected to as being dependent upon a rejected base claim, but would be allowable if rewritten in independent form including all of the limitations of the base claim and any intervening claims.

9. Claims 20 and 22-24 would be allowable if rewritten to overcome the rejection(s) under 35 U.S.C. 112(b) or 35 U.S.C. 112 (pre-AIA), 2nd paragraph, set forth in this Office action and to include all of the limitations of the base claim and any intervening claims.

10. The prior art made of record and not relied upon is considered pertinent to applicant's disclosure. Banyay et al (9,212,898) is cited for disclosing a device for three dimensional confocal measurement. Kocherscheidt et al (9,456,754) is cited for disclosing a device for recording three dimensional images of a dental object.

11. Any inquiry concerning this communication or earlier communications from the examiner should be directed to KEVIN PYO whose telephone number is (571)272-2445. The examiner can normally be reached on Mon-Fri (with flexible hour), First Mon. off.

Examiner interviews are available via telephone, in-person, and video conferencing using a USPTO supplied web-based collaboration tool. To schedule an interview, applicant is encouraged to use the USPTO Automated Interview Request (AIR) at <http://www.uspto.gov/interviewpractice>.

If attempts to reach the examiner by telephone are unsuccessful, the examiner's supervisor, Georgia Y. Epps can be reached on (571) 272-2328. The fax phone number for the organization where this application or proceeding is assigned is 571-273-8300.

Information regarding the status of an application may be obtained from the Patent Application Information Retrieval (PAIR) system. Status information for published applications may be obtained from either Private PAIR or Public PAIR. Status information for unpublished applications is available through Private PAIR only. For more information about the PAIR system, see <http://pair-direct.uspto.gov>. Should you have questions on access to the Private PAIR system, contact the Electronic Business Center (EBC) at 866-217-9197 (toll-free). If you would like assistance from a USPTO Customer Service Representative or access to the automated information system, call 800-786-9199 (IN USA OR CANADA) or 571-272-1000.

/KEVIN PYO/
Primary Examiner, Art Unit 2878

Notice of References Cited	Application/Control No. 14/764,087	Applicant(s)/Patent Under Reexamination ESBECH ET AL.	
	Examiner KEVIN PYO	Art Unit 2878	Page 1 of 1

U.S. PATENT DOCUMENTS

*		Document Number Country Code-Number-Kind Code	Date MM-YYYY	Name	CPC Classification	US Classification
*	A	US-9,456,754 B2	10-2016	Kocherscheidt; Gerrit	A61B5/0088	1/1
*	B	US-9,212,898 B2	12-2015	Banyay; Matus	G02B21/0072	1/1
	C	US-				
	D	US-				
	E	US-				
	F	US-				
	G	US-				
	H	US-				
	I	US-				
	J	US-				
	K	US-				
	L	US-				
	M	US-				

FOREIGN PATENT DOCUMENTS

*		Document Number Country Code-Number-Kind Code	Date MM-YYYY	Country	Name	CPC Classification
	N					
	O					
	P					
	Q					
	R					
	S					
	T					

NON-PATENT DOCUMENTS

*		Include as applicable: Author, Title Date, Publisher, Edition or Volume, Pertinent Pages)
	U	
	V	
	W	
	X	

*A copy of this reference is not being furnished with this Office action. (See MPEP § 707.05(a).)
Dates in MM-YYYY format are publication dates. Classifications may be US or foreign.

Receipt date: 08/26/2016

Doc code: IDS
 Doc description: Information Disclosure Statement (IDS) Filed

PTO/SB/08a (01-10)
 Approved for use through 07/31/2012. OMB 0651-0031
 U.S. Patent and Trademark Office; U.S. DEPARTMENT OF COMMERCE
 Under the Paperwork Reduction Act of 1995, no persons are required to respond to a collection of information unless it contains a valid OMB control number.

INFORMATION DISCLOSURE STATEMENT BY APPLICANT (Not for submission under 37 CFR 1.99)	Application Number	14764087
	Filing Date	2015-07-28
	First Named Inventor	Bo ESBECH et al.
	Art Unit	2878
	Examiner Name	EPPS, GEORGIA PYO
	Attorney Docket Number	0079124-000111

U.S.PATENTS							Remove
Examiner Initial*	Cite No	Patent Number	Kind Code ¹	Issue Date	Name of Patentee or Applicant of cited Document	Pages,Columns,Lines where Relevant Passages or Relevant Figures Appear	
	1						

If you wish to add additional U.S. Patent citation information please click the Add button.

Add

U.S.PATENT APPLICATION PUBLICATIONS							Remove
Examiner Initial*	Cite No	Publication Number	Kind Code ¹	Publication Date	Name of Patentee or Applicant of cited Document	Pages,Columns,Lines where Relevant Passages or Relevant Figures Appear	
	1	20100145898	A1	2010-06-10	Malfliet et al.		
	2	20110134225	A1	2011-06-09	Saint-Pierre et al.	(Corresponds to CN 102112845)	
	3	20120062716	A1	2012-03-15	Dillon et al.	(Corresponds to CN 102402799)	
	4	20130236850	A1	2013-09-12	Wu et al.	(Corresponds to CN 102008282)	

If you wish to add additional U.S. Published Application citation information please click the Add button.

Add

FOREIGN PATENT DOCUMENTS								Remove
Examiner Initial*	Cite No	Foreign Document Number ³	Country Code ² i	Kind Code ⁴	Publication Date	Name of Patentee or Applicant of cited Document	Pages,Columns,Lines where Relevant Passages or Relevant Figures Appear	T ⁵

INFORMATION DISCLOSURE STATEMENT BY APPLICANT (Not for submission under 37 CFR 1.99)	Application Number		14764087	
	Filing Date		2015-07-28	
	First Named Inventor	Bo ESBECH et al.		
	Art Unit	2878		
	Examiner Name	EPPS, GEORGIA Y PYO		
	Attorney Docket Number	0079124-000111		

1	102008282	CN	A	2011-04-13	Univ Shenzhen	(with English Abstract)
2	102112845	CN	A	2011-06-29	Creaform Inc	(with English Abstract)
3	102402799	CN	A	2012-04-04	Dimensional Photonics Internat Inc	(with English Abstract)
4	102802520	CN	A	2012-11-28	3Shape AS	(with English Abstract) (Corresponds to US 2012/0092461 and WO 2010/145669 previously cited on
5	2012/007003	WO	A1	2012-01-19	3Shape AS	

If you wish to add additional Foreign Patent Document citation information please click the Add button

NON-PATENT LITERATURE DOCUMENTS

Examiner Initials*	Cite No	Include name of the author (in CAPITAL LETTERS), title of the article (when appropriate), title of the item (book, magazine, journal, serial, symposium, catalog, etc), date, pages(s), volume-issue number(s), publisher, city and/or country where published.	T ⁵
	1	The First Office Action issued on August 2, 2016, by the State Intellectual Property Office of People's Republic of China in corresponding Chinese Patent Application No. 201480020976.3, and an English Translation of the Office Action. (18 pages)	X
	2	The First Chinese Search issued on July 25, 2016, by the State Intellectual Property Office of People's Republic of China in corresponding Chinese Patent Application No. 201480020976.3. (2 pages)	<input type="checkbox"/>

If you wish to add additional non-patent literature document citation information please click the Add button

EXAMINER SIGNATURE

Examiner Signature	/KEVIN K PYO/	Date Considered	07/09/2017
--------------------	---------------	-----------------	------------

*EXAMINER: Initial if reference considered, whether or not citation is in conformance with MPEP 609. Draw line through a citation if not in conformance and not considered. Include copy of this form with next communication to applicant.

ALL REFERENCES CONSIDERED EXCEPT WHERE LINED THROUGH. /KP/

Index of Claims 	Application/Control No. 14764087	Applicant(s)/Patent Under Reexamination ESBECH ET AL.
	Examiner KEVIN PYO	Art Unit 2878

✓	Rejected	-	Cancelled	N	Non-Elected	A	Appeal
=	Allowed	÷	Restricted	I	Interference	O	Objected

Claims renumbered in the same order as presented by applicant
 CPA
 T.D.
 R.1.47

CLAIM		DATE									
Final	Original	07/09/2017									
	1	✓									
	2	✓									
	3	✓									
	4	✓									
	5	✓									
	6	✓									
	7	✓									
	8	✓									
	9	✓									
	10	✓									
	11	✓									
	12	○									
	13	✓									
	14	○									
	15	○									
	16	○									
	17	✓									
	18	✓									
	19	✓									
	20	✓									
	21	✓									
	22	✓									
	23	✓									
	24	✓									
	25	✓									
	26	✓									
	27	✓									
	28	✓									
	29	✓									
	30	✓									
	31	○									

Receipt date: 07/28/2015

Substitute for PTO/SB/08a&b (07-09)
 Approved for use through 07/31/2012. OMB 0651-0031
 U.S. Patent and Trademark Office; U.S. DEPARTMENT OF COMMERCE

Under the Paperwork Reduction Act of 1995, no persons are required to respond to a collection of information unless it contains a valid OMB control number.

Substitute for form 1449/PTO INFORMATION DISCLOSURE STATEMENT BY APPLICANT (Use as many sheets as necessary)		Complete if Known	
		Application Number	Unassigned 14764087 - GAU: 2878
		Filing Date	July 28, 2015
		First Named Inventor	Bo ESBECH et al.
		Art Unit	Unassigned
Sheet 1 of 1	Examiner Name	Unassigned pyo	
		Attorney Docket Number	0079124-000111

U.S. PATENT DOCUMENTS					
Examiner Initials ¹	Cite No. ¹	Document Number	Publication Date MM-DD-YYYY	Name of Patentee or Applicant of Cited Document	Pages, Columns, Lines, Where Relevant Passages or Relevant Figures Appear
		Number-Kind Code ² (if known)			
		US-2012/0075425 A1	03-29-2012	Thiel	
		US-2012/0092461 A1	04-19-2012	Fisker et al. (corr. to WO 2010/145669 below)	
		US-2014/0022356 A1	01-23-2014	Fisker et al. (corr. to WO 2012//083967 below)	
		US-7,698,068 B2	04-13-2010	Babayoff	
		US-8,102,538 B2	01-24-2012	Babayoff	
		US-2011/0221880 A1	09-15-2011	Liang et al. (corr. to EP 2241248 below)	
		US-2005/0285027 A1	12-29-2005	Favalora et al.	
		US-2012/0140243 A1	06-07-2012	Colonna de Lega	
		US-2014/0146142 S2	05-29-2014	Duret et al. (corr. to WO 2013/008097 below)	
		US-			
		US-			
		US-			
		US-			

FOREIGN PATENT DOCUMENTS						
Examiner Initials ¹	Cite No. ¹	Foreign Patent Document	Publication Date MM-DD-YYYY	Name of Patentee or Applicant of Cited Document	Pages, Columns, Lines, Where Relevant Passages or Relevant Figures Appear	T ⁶
		Country Code ³ Number ⁴ Kind Code ⁵ (if known)				
		WO 2010/145669 A1	12-23-2010	3SHAPE A/S		
		WO 2012/083967 A1	06-28-2012	3SHAPE A/S		
		JP 2004-029373 A (w/English abstract)	01-29-2004	KEYENCE CO LTD		
		EP 2 241 248 A2	10-20-2010	CARESTREAM HEALTH INC		
		WO 2013/008097 A1	01-17-2013	DURET FRANCOIS		

NON PATENT LITERATURE DOCUMENTS			
Examiner Initials*	Cite No. ¹	Include name of the author (in CAPITAL LETTERS), title of the article (when appropriate), title of the item (book, magazine, journal, serial, symposium, catalog, etc.), date, page(s), volume-issue number(s), publisher, city and/or country where published.	T ²
		International Search Report (PCT/ISA/210) mailed on July 7, 2014, by the European Patent Office as the International Searching Authority for International Application No. PCT/EP2014/052842.	

Examiner Signature	/KEVIN K PYO/	Date Considered	07/09/2017
--------------------	---------------	-----------------	------------

*EXAMINER: Initial if reference considered, whether or not citation is in conformance with MPEP 609. Draw line through citation if not in conformance and not considered. Include copy of this form with next communication to applicant. ¹ Applicant's unique citation designation number (optional). ² See Kinds Codes of USPTO Patent Documents at www.uspto.gov or MPEP 901.04. ³ Enter Office that issued the document, by the two-letter code (WIPO Standard ST.3). ⁴ For Japanese patent documents, the indication of the year of the reign of the Emperor must precede the serial number of the patent document. ⁵ Kind of document by the appropriate symbols as indicated on the document under WIPO Standard ST.16 if possible. ⁶ Applicant is to place a check mark here if English language Translation is attached.

ALL REFERENCES CONSIDERED EXCEPT WHERE LINED THROUGH. /KP/

EAST Search History

EAST Search History (Prior Art)

Ref #	Hits	Search Query	DBs	Default Operator	Plurals	Time Stamp
L1	272	robert near dillon	US-PGPUB; USPAT; USOCR; FPRS; EPO; JPO; DERWENT; IBM_TDB	OR	OFF	2017/07/09 20:10
L2	1902	bing near zhao	US-PGPUB; USPAT; USOCR; FPRS; EPO; JPO; DERWENT; IBM_TDB	OR	OFF	2017/07/09 20:10
L3	13	L1 and L2	US-PGPUB; USPAT; USOCR; FPRS; EPO; JPO; DERWENT; IBM_TDB	OR	OFF	2017/07/09 20:10
L4	7	L3 and color	US-PGPUB; USPAT; USOCR; FPRS; EPO; JPO; DERWENT; IBM_TDB	OR	OFF	2017/07/09 20:10
L5	5	"20120140243"	US-PGPUB; USPAT; USOCR; FPRS; EPO; JPO; DERWENT; IBM_TDB	OR	OFF	2017/07/09 20:10
L6	5	"20120140243"	US-PGPUB; USPAT; USOCR; FPRS; EPO; JPO; DERWENT; IBM_TDB	OR	OFF	2017/07/09 20:10
L7	2	L6 and white	US-PGPUB; USPAT; USOCR; FPRS; EPO; JPO; DERWENT; IBM_TDB	OR	OFF	2017/07/09 20:10
L8	2	L6 and bayer	US-PGPUB;	OR	OFF	2017/07/09

EAST Search History

			USPAT; USOCR; FPRS; EPO; JPO; DERWENT; IBM_TDB			20:10
L9	3	"20150054922"	US-PGPUB; USPAT; USOCR; FPRS; EPO; JPO; DERWENT; IBM_TDB	OR	OFF	2017/07/09 20:10
L10	5	"20120140243"	US-PGPUB; USPAT; USOCR; FPRS; EPO; JPO; DERWENT; IBM_TDB	OR	OFF	2017/07/09 20:10
L11	2	L10 and bayer	US-PGPUB; USPAT; USOCR; FPRS; EPO; JPO; DERWENT; IBM_TDB	OR	OFF	2017/07/09 20:10
L12	5	"20120140243"	US-PGPUB; USPAT; USOCR; FPRS; EPO; JPO; DERWENT; IBM_TDB	OR	OFF	2017/07/09 20:10
L13	2	L12 and bayer and color	US-PGPUB; USPAT; USOCR; FPRS; EPO; JPO; DERWENT; IBM_TDB	OR	OFF	2017/07/09 20:10
L14	5	"20120140243"	US-PGPUB; USPAT; USOCR; FPRS; EPO; JPO; DERWENT; IBM_TDB	OR	OFF	2017/07/09 20:10
L15	2	L14 and bayer and color	US-PGPUB; USPAT; USOCR; FPRS; EPO; JPO; DERWENT; IBM_TDB	OR	OFF	2017/07/09 20:10
L16	3	"20160022389"	US-PGPUB; USPAT; USOCR; FPRS; EPO; JPO; DERWENT;	OR	OFF	2017/07/09 20:10

EAST Search History

			IBM_TDB			
L17	3	"20160022389"	US-PGPUB; USPAT; USOCR; FPRS; EPO; JPO; DERWENT; IBM_TDB	OR	OFF	2017/07/09 20:10
L18	1	L17 and weight	US-PGPUB; USPAT; USOCR; FPRS; EPO; JPO; DERWENT; IBM_TDB	OR	OFF	2017/07/09 20:10
L19	0	"20120140243" and weight	US-PGPUB; USPAT; USOCR; FPRS; EPO; JPO; DERWENT; IBM_TDB	OR	OFF	2017/07/09 20:10
L20	2	"20160022389" and color	US-PGPUB; USPAT; USOCR; FPRS; EPO; JPO; DERWENT; IBM_TDB	OR	OFF	2017/07/09 20:10
L21	1	"20160022389" and (color with digital)	US-PGPUB; USPAT; USOCR; FPRS; EPO; JPO; DERWENT; IBM_TDB	OR	OFF	2017/07/09 20:10
L22	5	"20120140243"	US-PGPUB; USPAT; USOCR; FPRS; EPO; JPO; DERWENT; IBM_TDB	OR	OFF	2017/07/09 20:10
L23	0	L22 and oral	US-PGPUB; USPAT; USOCR; FPRS; EPO; JPO; DERWENT; IBM_TDB	OR	OFF	2017/07/09 20:10
L24	5	"20120140243"	US-PGPUB; USPAT; USOCR; FPRS; EPO; JPO; DERWENT; IBM_TDB	OR	OFF	2017/07/09 20:10
L25	2	L24 and endoscop\$3	US-PGPUB; USPAT; USOCR; FPRS;	OR	OFF	2017/07/09 20:10

EAST Search History

			EPO; JPO; DERWENT; IBM_TDB			
L26	5	"20120075425"	US-PGPUB; USPAT; USOCR; FPRS; EPO; JPO; DERWENT; IBM_TDB	OR	OFF	2017/07/09 20:10
L27	5	"20120140243"	US-PGPUB; USPAT; USOCR; FPRS; EPO; JPO; DERWENT; IBM_TDB	OR	OFF	2017/07/09 20:10
L28	6	"20120092461"	US-PGPUB; USPAT; USOCR; FPRS; EPO; JPO; DERWENT; IBM_TDB	OR	OFF	2017/07/09 20:10
L29	2	L28 and color	US-PGPUB; USPAT; USOCR; FPRS; EPO; JPO; DERWENT; IBM_TDB	OR	OFF	2017/07/09 20:10
L30	2	"20120092461" and weight\$3	US-PGPUB; USPAT; USOCR; FPRS; EPO; JPO; DERWENT; IBM_TDB	OR	OFF	2017/07/09 20:10
L31	3	"20120092461" and correlation	US-PGPUB; USPAT; USOCR; FPRS; EPO; JPO; DERWENT; IBM_TDB	OR	OFF	2017/07/09 20:10
L32	2	"20120092461" and averag\$3	US-PGPUB; USPAT; USOCR; FPRS; EPO; JPO; DERWENT; IBM_TDB	OR	OFF	2017/07/09 20:10
L33	2	"20120092461" and remov\$3	US-PGPUB; USPAT; USOCR; FPRS; EPO; JPO; DERWENT; IBM_TDB	OR	OFF	2017/07/09 20:10
L34	3	"20120092461" and pixel\$2	US-PGPUB; USPAT;	OR	OFF	2017/07/09 20:10

EAST Search History

			USOCR; FPRS; EPO; JPO; DERWENT; IBM_TDB			
L35	45	("20120140243" "20120062716" "20050285027" "20120092461" "8102538" "20130236850" "20110221880" "20140022356" "7698068" "20140146142" "20110134225" "20120075425" "20100145898").PN.	US-PGPUB; USPAT; USOCR; FPRS; EPO; JPO; DERWENT; IBM_TDB	OR	OFF	2017/07/09 20:29
L36	49	("20010002310" "20030026469" "20030219148" "20040029068" "4836674" "5417572" "5431562" "5743730" "5766006" "5800164" "5851113" "5871351" "6007332" "6030209" "6033222" "6118521" "6190170" "6238567" "6239868" "6246479" "6379593" "6409504" "6417917" "6525819" "6538726" "6570654" "6573984" "6621491" "6739869" "6819318" "6957118" "7110594" "7110844" "7296996" "7383094").PN. OR ("7698068").URPN.	US-PGPUB; USPAT; USOCR	OR	OFF	2017/07/09 20:52
L37	2	("2012/0075425").URPN.	USPAT	OR	OFF	2017/07/09 20:54
L38	17	("2012/0092461").URPN.	USPAT	OR	OFF	2017/07/09 20:55
L39	4490	(dental or oral or intraoral) near3 scan\$4	US-PGPUB; USPAT; USOCR; FPRS; EPO; JPO; DERWENT; IBM_TDB	OR	OFF	2017/07/09 20:58
L40	121689	color with scan\$4	US-PGPUB; USPAT; USOCR; FPRS; EPO; JPO; DERWENT; IBM_TDB	OR	OFF	2017/07/09 21:01
L41	416	39 and 40	US-PGPUB; USPAT; USOCR; FPRS; EPO; JPO; DERWENT; IBM_TDB	OR	OFF	2017/07/09 21:02
L42	42281	focus\$3 near3 scan\$4	US-PGPUB; USPAT; USOCR; FPRS; EPO; JPO; DERWENT; IBM_TDB	OR	OFF	2017/07/09 21:02
L43	88	41 and 42	US-PGPUB; USPAT; USOCR; FPRS;	OR	OFF	2017/07/09 21:03

EAST Search History

			EPO; JPO; DERWENT; IBM_TDB			
L44	194088	surface near3 color	US-PGPUB; USPAT; USOCR; FPRS; EPO; JPO; DERWENT; IBM_TDB	OR	ON	2017/07/09 21:03
L45	61333	surface near3 (geometry or topography)	US-PGPUB; USPAT; USOCR; FPRS; EPO; JPO; DERWENT; IBM_TDB	OR	ON	2017/07/09 21:05
L46	2351	44 and 45	US-PGPUB; USPAT; USOCR; FPRS; EPO; JPO; DERWENT; IBM_TDB	OR	ON	2017/07/09 21:05
L47	83	42 and 46	US-PGPUB; USPAT; USOCR; FPRS; EPO; JPO; DERWENT; IBM_TDB	OR	ON	2017/07/09 21:05
L48	2634	348/47.ccls.	US-PGPUB; USPAT; USOCR; FPRS; EPO; JPO; DERWENT; IBM_TDB	OR	ON	2017/07/09 21:06
L49	2480	250/234.ccls.	US-PGPUB; USPAT; USOCR; FPRS; EPO; JPO; DERWENT; IBM_TDB	OR	ON	2017/07/09 21:06
L50	3529	250/226.ccls.	US-PGPUB; USPAT; USOCR; FPRS; EPO; JPO; DERWENT; IBM_TDB	OR	ON	2017/07/09 21:06
L52	11998	G01B11/24.cpc.	US-PGPUB; USPAT; USOCR; FPRS; EPO; JPO; DERWENT; IBM_TDB	OR	ON	2017/07/09 21:07
L53	829	G01B11/2509.cpc.	US-PGPUB; USPAT;	OR	ON	2017/07/09 21:07

EAST Search History

			USOCR; FPRS; EPO; JPO; DERWENT; IBM_TDB			
L54	1732	G01B11/2518.cpc.	US-PGPUB; USPAT; USOCR; FPRS; EPO; JPO; DERWENT; IBM_TDB	OR	ON	2017/07/09 21:08
L55	943	G01J3/508.cpc.	US-PGPUB; USPAT; USOCR; FPRS; EPO; JPO; DERWENT; IBM_TDB	OR	ON	2017/07/09 21:08
L56	23603	48 49 50 52 53 54 55	US-PGPUB; USPAT; USOCR; FPRS; EPO; JPO; DERWENT; IBM_TDB	OR	ON	2017/07/09 21:09
L57	77	56 and 46	US-PGPUB; USPAT; USOCR; FPRS; EPO; JPO; DERWENT; IBM_TDB	OR	ON	2017/07/09 21:09

EAST Search History (Interference)

<This search history is empty>

7/ 9/ 2017 9:11:45 PM

C:\Users\kpyo\Documents\EAST\Workspaces\14764087.wsp

Search Notes 	Application/Control No. 14764087	Applicant(s)/Patent Under Reexamination ESBECH ET AL.
	Examiner KEVIN PYO	Art Unit 2878

CPC- SEARCHED		
Symbol	Date	Examiner
G01B 11/24; 11/2509; 11/2518	7/9/17	kp

CPC COMBINATION SETS - SEARCHED		
Symbol	Date	Examiner

US CLASSIFICATION SEARCHED			
Class	Subclass	Date	Examiner
250	226; 234	7/9/17	kp
348	47	7/9/17	kp

SEARCH NOTES		
Search Notes	Date	Examiner
EAST-see search history printout	7/9/17	kp
Inventor name and assignee search	7/9/17	kp

INTERFERENCE SEARCH			
US Class/ CPC Symbol	US Subclass / CPC Group	Date	Examiner

--	--

IN THE UNITED STATES PATENT AND TRADEMARK OFFICE

In re Patent Application of)	Group Art Unit: 2878
)	
Bo ESBECH et al.)	Confirmation No.: 6247
)	
Application No.: 14/764,087)	
)	
Filed: July 28, 2015)	
)	
For: FOCUS SCANNING APPARATUS RECORDING)	
COLOR)	

AMENDMENT

Commissioner for Patents
P.O. Box 1450
Alexandria, VA 22313-1450

Commissioner:

In response to the Official Action (*non-final rejection*) of July 17, 2017, kindly amend the application as follows.

AMENDMENTS TO THE CLAIMS:

The following listing of claims will replace all prior versions and listings of claims in this application.

LISTING OF CLAIMS:

1. (Currently Amended) A focus scanner for recording surface geometry and surface color of an object, the focus scanner comprising:
 - a multichromatic light source configured for providing a multichromatic probe light for illumination of the object,
 - a color image sensor comprising an array of image sensor pixels for capturing one or more 2D images of light received from said object,
 - wherein the focus scanner is configured to operate by translating a focus plane along an optical axis of the focus scanner and capturing a series of the 2D images, each 2D image of the series is at a different focus plane position such that the series of captured 2D images forms a stack of 2D images; and
 - a data processing system configured to derive surface geometry information for a block of said image sensor pixels from the 2D images in the stack of 2D images captured by said color image sensor, the data processing system also configured to derive surface color information for the block of said image sensor pixels from at least one of the 2D images used to derive the surface geometry information;

wherein the data processing system further is configured to combining a number of sub-scans to generate a digital 3D representation of the object, and determining object color of a least one point of the generated digital 3D representation of the object from sub-scan color of the sub-scans combined to generate the digital 3D representation, such that the digital 3D representation expresses both geometry and color profile of the object, and

wherein determining the object color comprises computing a weighted average of sub-scan color values derived for corresponding points in overlapping sub-scans at that point of the object surface.

2. (Previously Presented) The focus scanner according to claim 1, wherein the data processing system is configured for generating a sub-scan of a part of the object surface based on surface geometry information and surface color information derived from a plurality of blocks of image sensor pixels.

3. (Canceled)

4. (Previously Presented) The focus scanner according to claim 1, where the scanner system comprises a pattern generating element configured for incorporating a spatial pattern in said probe light.

5. (Previously Presented) The focus scanner according to claim 1, where deriving the surface geometry information and surface color information comprises calculating for several 2D images a correlation measure between the portion of the 2D image captured by said block of image sensor pixels and a weight function, where the weight function is determined based on information of the configuration of the spatial pattern.

6. (Previously Presented) The focus scanner according to claim 5, wherein deriving the surface geometry information and the surface color information for a block of image sensor pixels comprises identifying the position along the optical axis at which the corresponding correlation measure has a maximum value.

7. (Previously Presented) The focus scanner according to claim 6, wherein generating a sub-scan comprises determining a correlation measure function describing the variation of the correlation measure along the optical axis for each block of image sensor pixels and identifying the position along the optical axis at which the correlation measure functions have their maximum value for the block.

8. (Previously Presented) The focus scanner according to claim 7, where the maximum correlation measure value is the highest calculated correlation measure value for the block of image sensor pixels and/or the highest maximum value of the correlation measure function for the block of image sensor pixels.

9. (Previously Presented) The focus scanner according to claim 6, wherein the data processing system is configured for determining a sub-scan color for a point on a generated sub-scan based on the surface color information of the 2D image in the series in which the correlation measure has its maximum value for the corresponding block of image sensor pixels.

10. (Previously Presented) The focus scanner according to claim 9, wherein the data processing system is configured for deriving the sub-scan color for a point on a generated sub-scan based on the surface color information of the 2D images in the series in which the correlation measure has its maximum value for the corresponding block of image sensor pixels and on at least one additional 2D image.

11. (Currently Amended) The focus scanner according to claim 10, where the data processing system is configured for interpolating surface color information of at least two 2D images in a series when determining the sub-scan color, ~~such as an interpolation of surface color information of neighboring 2D images in a series.~~

12. (Previously Presented) The focus scanner according to claim 10, wherein the data processing system is configured for computing an averaged sub-scan color for a number of points of the sub-scan, where the computing comprises an averaging of sub-scan colors of different points.

13. (Canceled)

14. (Canceled)

15. (Previously Presented) The focus scanner according to claim 1, wherein the data processing system is configured for detecting saturated pixels in the captured 2D images and for mitigating or removing the error in the derived surface color information or the sub-scan color caused by the pixel saturation.

16. (Previously Presented) The focus scanner according to claim 15, wherein the error caused by the saturated pixel is mitigated or removed by assigning a low weight to the surface color information of the saturated pixel in the computing of the smoothed sub-scan color and/or by assigning a low weight to the sub-scan color computed based on the saturated pixel.

17. (Currently Amended) The focus scanner according to claim 1, wherein the data processing system is configured for comparing the derived surface color information of sections of the captured 2D images ~~and~~/or of the generated sub-scans of the object with predetermined color ranges for teeth and for oral tissue, and for suppressing the red component of the derived

surface color information or sub-scan color for sections where the color is not in one of the two predetermined color ranges.

18. (Previously Presented) The focus scanner according to claim 1, where the color image sensor comprises a color filter array comprising at least three types of colors filters, each allowing light in a known wavelength range, W1, W2, and W3 respectively, to propagate through the color filter.

19. (Currently Amended) The focus scanner according to claim ~~[[1]]~~ 18, where the surface geometry information is derived from light in a selected wavelength range of the spectrum provided by the multichromatic light source.

20. (Previously Presented) The focus scanner according to claim 19, where the color filter array is such that the proportion of the image sensor pixels of the color image sensor with color filters that match the selected wavelength range of the spectrum is larger than 50%.

21. (Previously Presented) The focus scanner according to claim 19, wherein the selected wavelength range matches the W2 wavelength range.

22. (Currently Amended) The focus scanner according to claim ~~[[19]]~~ 18, wherein the color filter array comprises a plurality of cells of 6x6 color filters, where the color filters in

positions (2,2) and (5,5) of each cell are of the W1 type, the color filters in positions (2,5) and (5,2) are of the W3 type.

23. (Previously Presented) The focus scanner according to claim 22, where the remaining 32 color filters in the 6x6 cell are of the W2 type.

24. (Currently Amended) The focus scanner according to claim ~~[[23]]~~ 4, where the pattern generating element is configured to provide that the spatial pattern comprises alternating dark and bright regions arranged in a checkerboard pattern.

25. (Previously Presented) A focus scanner for recording surface geometry and surface color of an object, the focus scanner comprising:

a multichromatic light source configured for providing a multichromatic probe light, and
a color image sensor comprising an array of image sensor pixels for capturing one or more 2D images of light received from said object,

where at least for a block of said image sensor pixels, both surface color information and surface geometry information of a part of the object are derived at least partly from one 2D image captured by said color image sensor.

26. (Previously Presented) A method of recording surface geometry and surface color of an object, the method comprising:

obtaining a focus scanner according to claim 1;
illuminating the surface of said object with multichromatic probe light from said multichromatic light source;
capturing a series of 2D images of said object using said color image sensor; and
deriving both surface geometry information and surface color information for a block of image sensor pixels at least partly from one captured 2D image.

27. (Previously Presented) The focus scanner according to claim 1, wherein the same series of 2D images is taken from one pass of the focus scanner along the optical axis.

28. (Previously Presented) The focus scanner according to claim 1, wherein the multichromatic light source, the color image sensor, and at least a portion of the data processing system are included in a hand held unit.

29. (Previously Presented) The focus scanner according to claim 19, where the color filter array is such that the proportion of the image sensor pixels of the color image sensor with color filters that match the selected wavelength range of the spectrum has a proportion that equals 32/36, 60/64 or 96/100.

30. (Previously Presented) The focus scanner according to claim 10, wherein said at least one additional 2D image comprises a neighboring 2D image from the series of captured 2D images.

31. (Previously Presented) The focus scanner according to claim 12, wherein the averaging of sub-scan colors of different points comprises a weighted averaging of the colors of the surrounding points on the sub-scan.

32. (New) The focus scanner according to claim 11, where the interpolation is of surface color information of neighboring 2D images in a series.

33. (New) A focus scanner for recording surface geometry and surface color of an object, the focus scanner comprising:

a multichromatic light source configured for providing a multichromatic probe light for illumination of the object,

a color image sensor comprising an array of image sensor pixels for capturing one or more 2D images of light received from said object,

wherein the focus scanner is configured to operate by translating a focus plane along an optical axis of the focus scanner and capturing a series of the 2D images, each 2D image of the series is at a different focus plane position such that the series of captured 2D images forms a stack of 2D images; and

a data processing system configured to derive surface geometry information for a block of said image sensor pixels from the 2D images in the stack of 2D images captured by said color image sensor, the data processing system also configured to derive surface color information for the block of said image sensor pixels from at least one of the 2D images used to derive the surface geometry information, and

where the data processing system further is configured to detecting saturated pixels in the captured 2D images and for mitigating or removing the error in the derived surface color information or the sub-scan color caused by the pixel saturation.

34. (New) The scanner system according to claim 33, wherein the error caused by the saturated pixel is mitigated or removed by assigning a low weight to the surface color information of the saturated pixel in the computing of the smoothed sub-scan color and/or by assigning a low weight to the sub-scan color computed based on the saturated pixel.

35. (New) A focus scanner for recording surface geometry and surface color of an object, the focus scanner comprising:

a multichromatic light source configured for providing a multichromatic probe light for illumination of the object,

a color image sensor comprising an array of image sensor pixels for capturing one or more 2D images of light received from said object, where the color image sensor comprises a

color filter array comprising at least three types of colors filters, each allowing light in a known wavelength range, W1, W2, and W3 respectively, to propagate through the color filter;

wherein the focus scanner is configured to operate by translating a focus plane along an optical axis of the focus scanner and capturing a series of the 2D images, each 2D image of the series is at a different focus plane position such that the series of captured 2D images forms a stack of 2D images; and

a data processing system configured to derive surface geometry information for a block of said image sensor pixels from the 2D images in the stack of 2D images captured by said color image sensor, the data processing system also configured to derive surface color information for the block of said image sensor pixels from at least one of the 2D images used to derive the surface geometry information,

where the data processing system further is configured to derive the surface geometry information is derived from light in a selected wavelength range of the spectrum provided by the multichromatic light source, and where the color filter array is such that its proportion of pixels with color filters that match the selected wavelength range of the spectrum is larger than 50%.

36. (New) A focus scanner for recording surface geometry and surface color of an object, the focus scanner comprising:

a multichromatic light source configured for providing a multichromatic probe light for illumination of the object,

a color image sensor comprising an array of image sensor pixels for capturing one or more 2D images of light received from said object,

wherein the focus scanner is configured to operate by translating a focus plane along an optical axis of the focus scanner and capturing a series of the 2D images, each 2D image of the series is at a different focus plane position such that the series of captured 2D images forms a stack of 2D images; and

a data processing system configured to derive surface geometry information for a block of said image sensor pixels from the 2D images in the stack of 2D images captured by said color image sensor, the data processing system also configured to derive surface color information for the block of said image sensor pixels from at least one of the 2D images used to derive the surface geometry information;

where the color image sensor comprises a color filter array comprising at least three types of colors filters, each allowing light in a known wavelength range, W1, W2, and W3 respectively, to propagate through the color filter and the filters are arranged in a plurality of cells of 6x6 color filters, where the color filters in positions (2,2) and (5,5) of each cell are of the W1 type, the color filters in positions (2,5) and (5,2) are of the W3 type.

37. (New) The focus scanner according to claim 36, where the remaining 32 color filters in the 6x6 cell are of the W2 type.

38. (New) A focus scanner for recording surface geometry and surface color of an object, the focus scanner comprising:

a multichromatic light source configured for providing a multichromatic probe light for illumination of the object,

a color image sensor comprising an array of image sensor pixels for capturing one or more 2D images of light received from said object,

wherein the focus scanner is configured to operate by translating a focus plane along an optical axis of the focus scanner and capturing a series of the 2D images, each 2D image of the series is at a different focus plane position such that the series of captured 2D images forms a stack of 2D images; and

a data processing system configured to derive surface geometry information for a block of said image sensor pixels from the 2D images in the stack of 2D images captured by said color image sensor, the data processing system also configured to derive surface color information for the block of said image sensor pixels from at least one of the 2D images used to derive the surface geometry information, where deriving the surface geometry information and surface color information comprises calculating for several 2D images a correlation measure between the portion of the 2D image captured by said block of image sensor pixels and a weight function, where the weight function is determined based on information of the configuration of the spatial pattern, and identifying the position along the optical axis at which the corresponding correlation measure has a maximum value,

where the data processing system further is configured for determining a sub-scan color for a point on a generated sub-scan based on the surface color information of the 2D image in the series in which the correlation measure has its maximum value for the corresponding block of image sensor pixels and computing an averaged sub-scan color for a number of points of the sub-scan, where the computing comprises an averaging of sub-scan colors of surrounding points on the sub-scan.

39. (New) The focus scanner according to claim 38, wherein the averaging of sub-scan colors of surrounding points comprises a weighted averaging of the colors of the surrounding points on the sub-scan.

REMARKS

Allowable Subject Matter

The Office is thanked for the indication that claims 12, 14-16, 20, 22-24 and 31 contain allowable subject matter.

Independent claim 1 has been amended to incorporate the subject matter of allowable claim 14 (and intervening claims 3 and 13). Accordingly, claim 1 is respectfully requested to be allowed. All claims depending from claim 1 are further respectfully requested to be allowed.

New independent claim 33 has been added. Claim 33 relates to subject matter of allowable claim 15. Entry, consideration and allowance of claim 33 are respectfully requested.

New independent claim 35 has been added. Claim 35 relates to subject matter of allowable claim 20 (and intervening claims 18 and 19). Entry, consideration and allowance of claim 35 are respectfully requested.

New independent claim 36 has been added. Claim 36 relates to subject matter of allowable claim 22 (and intervening claim 18). Entry, consideration and allowance of claim 36 are respectfully requested.

New independent claim 38 has been added. Claim 38 relates to subject matter of allowable claim 12 (and intervening claims 5, 6, and 9, where the "*different points*" recitation in claim 12 is modified to "*surrounding points*"). Entry, consideration and allowance of claim 38 are respectfully requested.

Accordingly, all independent claims in the application are based on subject matter that the Office has indicated to be allowable. Allowance of the application is respectfully requested.

New Dependent Claims

In addition to the amendments discussed above, applicant has added:

new dependent claim 32, which is based on the "such as ..." recitation deleted from claim 11;

new dependent claim 34, support for which may be found in claim 16;

new dependent claim 37, support for which may be found in claim 23; and

new dependent claim 39, support for which may be found in claim 31.

35 USC 112

Claims 11, 17, 20, 22-24, and 29 stand rejected under 35 USC 112 as being indefinite.

Without acquiescing to the rejections, the Office is respectfully requested to consider the above claim amendments. Withdrawal of the rejection is requested.

35 USC 102 - Colonna

Claims 1-4, 13, 17, 19, 25, 26, and 27 stand rejected under 35 USC 102(e) as anticipated by Colonna (US 2012/0140243). This rejection is respectfully traversed.

Without acquiescing to this rejection, the rejection has been rendered moot by the amendments to claim 1. The rejection is respectfully requested to be withdrawn.

35 USC 102 - Fisker

Claims 1-11, 13, 17-19, 21, 25-28, and 30 stand rejected under 35 USC 102(e) as anticipated by Fisker (US 2012/0092461). This rejection is respectfully traversed.

Without acquiescing to this rejection, the rejection has been rendered moot by the amendments to claim 1. The rejection is respectfully requested to be withdrawn.

35 USC 103 – Colonna

Claims 21 and 28 stand rejected under 35 USC 103 as being unpatentable over Colonna. This rejection is respectfully traversed.

Without acquiescing to this rejection, the rejection has been rendered moot by the amendments to claim 1. The rejection is respectfully requested to be withdrawn.

Conclusion

Should any questions arise in connection with this application, it is respectfully requested that the undersigned be contacted at the number indicated below.

Respectfully submitted,

BUCHANAN INGERSOLL & ROONEY PC

Date: 17 November 2017

By: /Travis D. Boone/
Travis D. Boone
Registration No. 52635

Customer No. 21839
(703) 836-6620

Under the Paperwork Reduction Act of 1995, no persons are required to respond to a collection of information unless it displays a valid OMB control number.

PETITION FOR EXTENSION OF TIME UNDER 37 CFR 1.136(a)		Docket Number (Optional) 0079124-000111	
Application Number	14/764,087	Filed	July 28, 2015
For FOCUS SCANNING APPARATUS RECORDING COLOR			
Art Unit	2878	Examiner	PYO, KEVIN K

This is a request under the provisions of 37 CFR 1.136(a) to extend the period for filing a reply in the above identified application. The requested extension and fee are as follows (check time period desired and enter the appropriate fee below):

	Large Fee	Small Fee	Micro Fee		
<input checked="" type="checkbox"/> One month (37 CFR 1.17(a)(1))	\$200	\$100	\$50	\$	200
<input type="checkbox"/> Two month (37 CFR 1.17(a)(2))	\$600	\$300	\$150	\$	_____
<input type="checkbox"/> Three month (37 CFR 1.17(a)(3))	\$1,400	\$700	\$350	\$	_____
<input type="checkbox"/> Four month (37 CFR 1.17(a)(4))	\$2,200	\$1,100	\$550	\$	_____
<input type="checkbox"/> Five month (37 CFR 1.17(a)(5))	\$3,000	\$1,500	\$750	\$	_____

Applicant claims small entity status. See 37 CFR 1.27.

A check in the amount of the fee is enclosed.

Payment by credit card. Form PTO-2038 is attached.

The Director has already been authorized to charge fees in this application to a Deposit Account.

The Director is hereby authorized to charge any fees which may be required, or credit any overpayment, to Deposit Account Number **02-4800**.

Payment made via EFS-Web.

WARNING: Information on this form may become public. Credit card information should not be included on this form. Provide credit card information and authorization on PTO-2038.

I am the applicant.

attorney or agent of record. Registration number **52,635**.

attorney or agent acting under 37 CFR 1.34. Registration number **52,635**.

_____ /Travis D. Boone/ Signature	_____ 17 November 2017 Date
_____ Travis D. Boone Type or printed name	_____ 703-836-6620 Telephone Number

NOTE: This form must be signed in accordance with 37 CFR 1.33. See 37 CFR 1.4 for signature requirements and certifications. Submit multiple forms if more than one signature is required. See below*.

Total of ___ forms are submitted.

This collection of information is required by 37 CFR 1.136(a). The information is required to obtain or retain a benefit by the public which is to file (and by the USPTO to process) an application. Confidentiality is governed by 35 U.S.C. 122 and 37 CFR 1.11 and 1.14. This collection is estimated to take 8 minutes to complete, including gathering, preparing, and submitting the completed application form to the USPTO. Time will vary depending upon the individual case. Any comments on the amount of time you require to complete this form and/or suggestions for reducing this burden, should be sent to the Chief Information Officer, U.S. Patent and Trademark Office, U.S. Department of Commerce, P.O. Box 1450, Alexandria, VA 22313-1450. DO NOT SEND FEES OR COMPLETED FORMS TO THIS ADDRESS. SEND TO: Commissioner for Patents, P.O. Box 1450, Alexandria, VA 22313-1450.

Electronic Patent Application Fee Transmittal				
Application Number:	14764087			
Filing Date:	28-Jul-2015			
Title of Invention:	FOCUS SCANNING APPARATUS RECORDING COLOR			
First Named Inventor/Applicant Name:	Bo ESBECH			
Filer:	Travis Dean Boone/Denise Williams			
Attorney Docket Number:	00791 24-000111			
Filed as Large Entity				
Filing Fees for U.S. National Stage under 35 USC 371				
Description	Fee Code	Quantity	Amount	Sub-Total in USD(\$)
Basic Filing:				
Pages:				
Claims:				
CLAIMS IN EXCESS OF 20	1615	4	80	320
INDEPENDENT CLAIMS IN EXCESS OF 3	1614	2	420	840
Miscellaneous-Filing:				
Petition:				
Patent-Appeals-and-Interference:				

Description	Fee Code	Quantity	Amount	Sub-Total in USD(\$)
Post-Allowance-and-Post-Issuance:				
Extension-of-Time:				
Extension - 1 month with \$0 paid	1251	1	200	200
Miscellaneous:				
Total in USD (\$)				1360

Electronic Acknowledgement Receipt	
EFS ID:	30979010
Application Number:	14764087
International Application Number:	
Confirmation Number:	6247
Title of Invention:	FOCUS SCANNING APPARATUS RECORDING COLOR
First Named Inventor/Applicant Name:	Bo ESBECH
Customer Number:	21839
Filer:	Travis Dean Boone/Denise Williams
Filer Authorized By:	Travis Dean Boone
Attorney Docket Number:	00791 24-000111
Receipt Date:	17-NOV-2017
Filing Date:	28-JUL-2015
Time Stamp:	09:20:02
Application Type:	U.S. National Stage under 35 USC 371

Payment information:

Submitted with Payment	yes
Payment Type	CARD
Payment was successfully received in RAM	\$ 1360
RAM confirmation Number	111717INTEFSW09220000
Deposit Account	024800
Authorized User	Denise Miles
<p>The Director of the USPTO is hereby authorized to charge indicated fees and credit any overpayment as follows:</p> <p>37 CFR 1.17 (Patent application and reexamination processing fees)</p> <p>37 CFR 1.19 (Document supply fees)</p>	

37 CFR 1.20 (Post Issuance fees)					
37 CFR 1.21 (Miscellaneous fees and charges)					
37 CFR 1.492 (National application filing, search, and examination fees)					
37 CFR 1.492(a) (Basic national fee only)					
File Listing:					
Document Number	Document Description	File Name	File Size(Bytes)/ Message Digest	Multi Part /.zip	Pages (if appl.)
1		17-11-17-AMENDMENT.pdf	133309 9db40d4aff0f4cbbf3e309a16202f9a86af58d90	yes	18
Multipart Description/PDF files in .zip description					
Document Description			Start	End	
Amendment/Req. Reconsideration-After Non-Final Reject			1	1	
Claims			2	15	
Applicant Arguments/Remarks Made in an Amendment			16	18	
Warnings:					
Information:					
2	Extension of Time	17-11-17-EOT.pdf	89401 f7b91b311a993d21681e5f07adfa985a5c173728	no	1
Warnings:					
Information:					
3	Fee Worksheet (SB06)	fee-info.pdf	34195 61d5d9b1de1fc1a68a85a202fa334436df243ebd	no	2
Warnings:					
Information:					
Total Files Size (in bytes):			256905		

This Acknowledgement Receipt evidences receipt on the noted date by the USPTO of the indicated documents, characterized by the applicant, and including page counts, where applicable. It serves as evidence of receipt similar to a Post Card, as described in MPEP 503.

New Applications Under 35 U.S.C. 111

If a new application is being filed and the application includes the necessary components for a filing date (see 37 CFR 1.53(b)-(d) and MPEP 506), a Filing Receipt (37 CFR 1.54) will be issued in due course and the date shown on this Acknowledgement Receipt will establish the filing date of the application.

National Stage of an International Application under 35 U.S.C. 371

If a timely submission to enter the national stage of an international application is compliant with the conditions of 35 U.S.C. 371 and other applicable requirements a Form PCT/DO/EO/903 indicating acceptance of the application as a national stage submission under 35 U.S.C. 371 will be issued in addition to the Filing Receipt, in due course.

New International Application Filed with the USPTO as a Receiving Office

If a new international application is being filed and the international application includes the necessary components for an international filing date (see PCT Article 11 and MPEP 1810), a Notification of the International Application Number and of the International Filing Date (Form PCT/RO/105) will be issued in due course, subject to prescriptions concerning national security, and the date shown on this Acknowledgement Receipt will establish the international filing date of the application.

PATENT APPLICATION FEE DETERMINATION RECORD Substitute for Form PTO-875		Application or Docket Number 14/764,087		Filing Date 07/28/2015		<input type="checkbox"/> To be Mailed	
ENTITY: <input checked="" type="checkbox"/> LARGE <input type="checkbox"/> SMALL <input type="checkbox"/> MICRO							
APPLICATION AS FILED - PART I							
	(Column 1)	(Column 2)					
	FOR	NUMBER FILED	NUMBER EXTRA		RATE (\$)		FEE (\$)
<input type="checkbox"/>	BASIC FEE (37 CFR 1.16(a), (b), or (c))	N/A	N/A		N/A		
<input type="checkbox"/>	SEARCH FEE (37 CFR 1.16(k), (l), or (m))	N/A	N/A		N/A		
<input type="checkbox"/>	EXAMINATION FEE (37 CFR 1.16(c), (p), or (q))	N/A	N/A		N/A		
	TOTAL CLAIMS (37 CFR 1.16(j))	minus 20 = *			x \$80 =		
	INDEPENDENT CLAIMS (37 CFR 1.16(n))	minus 3 = *			x \$420 =		
<input type="checkbox"/>	APPLICATION SIZE FEE (37 CFR 1.16(s))	If the specification and drawings exceed 100 sheets of paper, the application size fee due is \$310 (\$155 for small entity) for each additional 50 sheets or fraction thereof. See 35 U.S.C. 41(a)(1)(G) and 37 CFR 1.16(s).					
<input type="checkbox"/>	MULTIPLE DEPENDENT CLAIM PRESENT (37 CFR 1.16(j))						
* If the difference in column 1 is less than zero, enter "0" in column 2.						TOTAL	
APPLICATION AS AMENDED - PART II							
	(Column 1)	(Column 2)	(Column 3)				
AMENDMENT	11/17/2017	CLAIMS REMAINING AFTER AMENDMENT	HIGHEST NUMBER PREVIOUSLY PAID FOR	PRESENT EXTRA	RATE (\$)		ADDITIONAL FEE (\$)
	Total (37 CFR 1.16(i))	* 36	Minus ** 31	= 5	x \$80 =		400
	Independent (37 CFR 1.16(b))	* 6	Minus *** 3	= 3	x \$420 =		1260
	<input type="checkbox"/> Application Size Fee (37 CFR 1.16(s))						
<input type="checkbox"/> FIRST PRESENTATION OF MULTIPLE DEPENDENT CLAIM (37 CFR 1.16(j))							
						TOTAL ADD'L FEE	1660
	(Column 1)	(Column 2)	(Column 3)				
AMENDMENT		CLAIMS REMAINING AFTER AMENDMENT	HIGHEST NUMBER PREVIOUSLY PAID FOR	PRESENT EXTRA	RATE (\$)		ADDITIONAL FEE (\$)
	Total (37 CFR 1.16(i))	*	Minus **	=	x \$ 0 =		
	Independent (37 CFR 1.16(b))	*	Minus ***	=	x \$ 0 =		
	<input type="checkbox"/> Application Size Fee (37 CFR 1.16(s))						
<input type="checkbox"/> FIRST PRESENTATION OF MULTIPLE DEPENDENT CLAIM (37 CFR 1.16(j))							
						TOTAL ADD'L FEE	
* If the entry in column 1 is less than the entry in column 2, write "0" in column 3.					LIE		
** If the "Highest Number Previously Paid For" IN THIS SPACE is less than 20, enter "20".					Moliki I May		
*** If the "Highest Number Previously Paid For" IN THIS SPACE is less than 3, enter "3".							
The "Highest Number Previously Paid For" (Total or Independent) is the highest number found in the appropriate box in column 1.							

This collection of information is required by 37 CFR 1.16. The information is required to obtain or retain a benefit by the public which is to file (and by the USPTO to process) an application. Confidentiality is governed by 35 U.S.C. 122 and 37 CFR 1.14. This collection is estimated to take 12 minutes to complete, including gathering, preparing, and submitting the completed application form to the USPTO. Time will vary depending upon the individual case. Any comments on the amount of time you require to complete this form and/or suggestions for reducing this burden, should be sent to the Chief Information Officer, U.S. Patent and Trademark Office, U.S. Department of Commerce, P.O. Box 1450, Alexandria, VA 22313-1450. DO NOT SEND FEES OR COMPLETED FORMS TO THIS ADDRESS. SEND TO: Commissioner for Patents, P.O. Box 1450, Alexandria, VA 22313-1450.

If you need assistance in completing the form, call 1-800-PTO-9199 and select option 2.

Document code: WFEE

United States Patent and Trademark Office
Sales Receipt for Accounting Date: 12/04/2017

MMAY22	SALE	#00000001	Mailroom Dt:	11/17/2017	024800	14764087
		01	FC : 1201		1,260.00	DA
		02	FC : 1202		400.00	DA



UNITED STATES PATENT AND TRADEMARK OFFICE

UNITED STATES DEPARTMENT OF COMMERCE
United States Patent and Trademark Office
Address: COMMISSIONER FOR PATENTS
P.O. Box 1450
Alexandria, Virginia 22313-1450
www.uspto.gov

NOTICE OF ALLOWANCE AND FEE(S) DUE

21839 7590 12/28/2017
BUCHANAN, INGERSOLL & ROONEY PC
POST OFFICE BOX 1404
ALEXANDRIA, VA 22313-1404

EXAMINER

PYO, KEVIN K

ART UNIT PAPER NUMBER

2878

DATE MAILED: 12/28/2017

Table with 5 columns: APPLICATION NO., FILING DATE, FIRST NAMED INVENTOR, ATTORNEY DOCKET NO., CONFIRMATION NO.

TITLE OF INVENTION: FOCUS SCANNING APPARATUS RECORDING COLOR

Table with 7 columns: APPLN. TYPE, ENTITY STATUS, ISSUE FEE DUE, PUBLICATION FEE DUE, PREV. PAID ISSUE FEE, TOTAL FEE(S) DUE, DATE DUE

THE APPLICATION IDENTIFIED ABOVE HAS BEEN EXAMINED AND IS ALLOWED FOR ISSUANCE AS A PATENT. PROSECUTION ON THE MERITS IS CLOSED. THIS NOTICE OF ALLOWANCE IS NOT A GRANT OF PATENT RIGHTS. THIS APPLICATION IS SUBJECT TO WITHDRAWAL FROM ISSUE AT THE INITIATIVE OF THE OFFICE OR UPON PETITION BY THE APPLICANT. SEE 37 CFR 1.313 AND MPEP 1308.

THE ISSUE FEE AND PUBLICATION FEE (IF REQUIRED) MUST BE PAID WITHIN THREE MONTHS FROM THE MAILING DATE OF THIS NOTICE OR THIS APPLICATION SHALL BE REGARDED AS ABANDONED. THIS STATUTORY PERIOD CANNOT BE EXTENDED. SEE 35 U.S.C. 151. THE ISSUE FEE DUE INDICATED ABOVE DOES NOT REFLECT A CREDIT FOR ANY PREVIOUSLY PAID ISSUE FEE IN THIS APPLICATION. IF AN ISSUE FEE HAS PREVIOUSLY BEEN PAID IN THIS APPLICATION (AS SHOWN ABOVE), THE RETURN OF PART B OF THIS FORM WILL BE CONSIDERED A REQUEST TO REAPPLY THE PREVIOUSLY PAID ISSUE FEE TOWARD THE ISSUE FEE NOW DUE.

HOW TO REPLY TO THIS NOTICE:

I. Review the ENTITY STATUS shown above. If the ENTITY STATUS is shown as SMALL or MICRO, verify whether entitlement to that entity status still applies.

If the ENTITY STATUS is the same as shown above, pay the TOTAL FEE(S) DUE shown above.

If the ENTITY STATUS is changed from that shown above, on PART B - FEE(S) TRANSMITTAL, complete section number 5 titled "Change in Entity Status (from status indicated above)".

For purposes of this notice, small entity fees are 1/2 the amount of undiscounted fees, and micro entity fees are 1/2 the amount of small entity fees.

II. PART B - FEE(S) TRANSMITTAL, or its equivalent, must be completed and returned to the United States Patent and Trademark Office (USPTO) with your ISSUE FEE and PUBLICATION FEE (if required). If you are charging the fee(s) to your deposit account, section "4b" of Part B - Fee(s) Transmittal should be completed and an extra copy of the form should be submitted. If an equivalent of Part B is filed, a request to reapply a previously paid issue fee must be clearly made, and delays in processing may occur due to the difficulty in recognizing the paper as an equivalent of Part B.

III. All communications regarding this application must give the application number. Please direct all communications prior to issuance to Mail Stop ISSUE FEE unless advised to the contrary.

IMPORTANT REMINDER: Maintenance fees are due in utility patents issuing on applications filed on or after Dec. 12, 1980. It is patentee's responsibility to ensure timely payment of maintenance fees when due. More information is available at www.uspto.gov/PatentMaintenanceFees.

PART B - FEE(S) TRANSMITTAL

Complete and send this form, together with applicable fee(s), to: **Mail Stop ISSUE FEE
Commissioner for Patents
P.O. Box 1450
Alexandria, Virginia 22313-1450**
or **Fax (571)-273-2885**

INSTRUCTIONS: This form should be used for transmitting the ISSUE FEE and PUBLICATION FEE (if required). Blocks 1 through 5 should be completed where appropriate. All further correspondence including the Patent, advance orders and notification of maintenance fees will be mailed to the current correspondence address as indicated unless corrected below or directed otherwise in Block 1, by (a) specifying a new correspondence address; and/or (b) indicating a separate "FEE ADDRESS" for maintenance fee notifications.

CURRENT CORRESPONDENCE ADDRESS (Note: Use Block 1 for any change of address)

21839 7590 12/28/2017
BUCHANAN, INGERSOLL & ROONEY PC
POST OFFICE BOX 1404
ALEXANDRIA, VA 22313-1404

Note: A certificate of mailing can only be used for domestic mailings of the Fee(s) Transmittal. This certificate cannot be used for any other accompanying papers. Each additional paper, such as an assignment or formal drawing, must have its own certificate of mailing or transmission.

Certificate of Mailing or Transmission

I hereby certify that this Fee(s) Transmittal is being deposited with the United States Postal Service with sufficient postage for first class mail in an envelope addressed to the Mail Stop ISSUE FEE address above, or being facsimile transmitted to the USPTO (571) 273-2885, on the date indicated below.

(Depositor's name)
(Signature)
(Date)

APPLICATION NO.	FILING DATE	FIRST NAMED INVENTOR	ATTORNEY DOCKET NO.	CONFIRMATION NO.
14/764,087	07/28/2015	Bo ESBECH	0079124-000111	6247

TITLE OF INVENTION: FOCUS SCANNING APPARATUS RECORDING COLOR

APPLN. TYPE	ENTITY STATUS	ISSUE FEE DUE	PUBLICATION FEE DUE	PREV. PAID ISSUE FEE	TOTAL FEE(S) DUE	DATE DUE
nonprovisional	UNDISCOUNTED	\$960	\$0	\$0	\$960	03/28/2018

EXAMINER	ART UNIT	CLASS-SUBCLASS
PYO, KEVIN K	2878	250-208100

1. Change of correspondence address or indication of "Fee Address" (37 CFR 1.363).

- Change of correspondence address (or Change of Correspondence Address form PTO/SB/122) attached.
- "Fee Address" indication (or "Fee Address" Indication form PTO/SB/47; Rev 03-02 or more recent) attached. **Use of a Customer Number is required.**

2. For printing on the patent front page, list

- (1) The names of up to 3 registered patent attorneys or agents OR, alternatively, 1 _____
- (2) The name of a single firm (having as a member a registered attorney or agent) and the names of up to 2 registered patent attorneys or agents. If no name is listed, no name will be printed. 2 _____
- 3 _____

3. ASSIGNEE NAME AND RESIDENCE DATA TO BE PRINTED ON THE PATENT (print or type)

PLEASE NOTE: Unless an assignee is identified below, no assignee data will appear on the patent. If an assignee is identified below, the document has been filed for recordation as set forth in 37 CFR 3.11. Completion of this form is NOT a substitute for filing an assignment.

(A) NAME OF ASSIGNEE

(B) RESIDENCE: (CITY and STATE OR COUNTRY)

Please check the appropriate assignee category or categories (will not be printed on the patent): Individual Corporation or other private group entity Government

4a. The following fee(s) are submitted:

- Issue Fee
- Publication Fee (No small entity discount permitted)
- Advance Order - # of Copies _____

4b. Payment of Fee(s): (Please first reapply any previously paid issue fee shown above)

- A check is enclosed.
- Payment by credit card. Form PTO-2038 is attached.
- The director is hereby authorized to charge the required fee(s), any deficiency, or credits any overpayment, to Deposit Account Number _____ (enclose an extra copy of this form).

5. Change in Entity Status (from status indicated above)

- Applicant certifying micro entity status. See 37 CFR 1.29
- Applicant asserting small entity status. See 37 CFR 1.27
- Applicant changing to regular undiscounted fee status.

NOTE: Absent a valid certification of Micro Entity Status (see forms PTO/SB/15A and 15B), issue fee payment in the micro entity amount will not be accepted at the risk of application abandonment.

NOTE: If the application was previously under micro entity status, checking this box will be taken to be a notification of loss of entitlement to micro entity status.

NOTE: Checking this box will be taken to be a notification of loss of entitlement to small or micro entity status, as applicable.

NOTE: This form must be signed in accordance with 37 CFR 1.31 and 1.33. See 37 CFR 1.4 for signature requirements and certifications.

Authorized Signature _____

Date _____

Typed or printed name _____

Registration No. _____



UNITED STATES PATENT AND TRADEMARK OFFICE

UNITED STATES DEPARTMENT OF COMMERCE
United States Patent and Trademark Office
Address: COMMISSIONER FOR PATENTS
P.O. Box 1450
Alexandria, Virginia 22313-1450
www.uspto.gov

Table with 5 columns: APPLICATION NO., FILING DATE, FIRST NAMED INVENTOR, ATTORNEY DOCKET NO., CONFIRMATION NO.
14/764,087 07/28/2015 Bo ESBECH 0079124-000111 6247

21839 7590 12/28/2017
BUCHANAN, INGERSOLL & ROONEY PC
POST OFFICE BOX 1404
ALEXANDRIA, VA 22313-1404

EXAMINER

PYO, KEVIN K

ART UNIT PAPER NUMBER

2878

DATE MAILED: 12/28/2017

Determination of Patent Term Adjustment under 35 U.S.C. 154 (b)
(Applications filed on or after May 29, 2000)

The Office has discontinued providing a Patent Term Adjustment (PTA) calculation with the Notice of Allowance.

Section 1(h)(2) of the AIA Technical Corrections Act amended 35 U.S.C. 154(b)(3)(B)(i) to eliminate the requirement that the Office provide a patent term adjustment determination with the notice of allowance. See Revisions to Patent Term Adjustment, 78 Fed. Reg. 19416, 19417 (Apr. 1, 2013). Therefore, the Office is no longer providing an initial patent term adjustment determination with the notice of allowance. The Office will continue to provide a patent term adjustment determination with the Issue Notification Letter that is mailed to applicant approximately three weeks prior to the issue date of the patent, and will include the patent term adjustment on the patent. Any request for reconsideration of the patent term adjustment determination (or reinstatement of patent term adjustment) should follow the process outlined in 37 CFR 1.705.

Any questions regarding the Patent Term Extension or Adjustment determination should be directed to the Office of Patent Legal Administration at (571)-272-7702. Questions relating to issue and publication fee payments should be directed to the Customer Service Center of the Office of Patent Publication at 1-(888)-786-0101 or (571)-272-4200.

OMB Clearance and PRA Burden Statement for PTOL-85 Part B

The Paperwork Reduction Act (PRA) of 1995 requires Federal agencies to obtain Office of Management and Budget approval before requesting most types of information from the public. When OMB approves an agency request to collect information from the public, OMB (i) provides a valid OMB Control Number and expiration date for the agency to display on the instrument that will be used to collect the information and (ii) requires the agency to inform the public about the OMB Control Number's legal significance in accordance with 5 CFR 1320.5(b).

The information collected by PTOL-85 Part B is required by 37 CFR 1.311. The information is required to obtain or retain a benefit by the public which is to file (and by the USPTO to process) an application. Confidentiality is governed by 35 U.S.C. 122 and 37 CFR 1.14. This collection is estimated to take 12 minutes to complete, including gathering, preparing, and submitting the completed application form to the USPTO. Time will vary depending upon the individual case. Any comments on the amount of time you require to complete this form and/or suggestions for reducing this burden, should be sent to the Chief Information Officer, U.S. Patent and Trademark Office, U.S. Department of Commerce, P.O. Box 1450, Alexandria, Virginia 22313-1450. DO NOT SEND FEES OR COMPLETED FORMS TO THIS ADDRESS. SEND TO: Commissioner for Patents, P.O. Box 1450, Alexandria, Virginia 22313-1450. Under the Paperwork Reduction Act of 1995, no persons are required to respond to a collection of information unless it displays a valid OMB control number.

Privacy Act Statement

The Privacy Act of 1974 (P.L. 93-579) requires that you be given certain information in connection with your submission of the attached form related to a patent application or patent. Accordingly, pursuant to the requirements of the Act, please be advised that: (1) the general authority for the collection of this information is 35 U.S.C. 2(b)(2); (2) furnishing of the information solicited is voluntary; and (3) the principal purpose for which the information is used by the U.S. Patent and Trademark Office is to process and/or examine your submission related to a patent application or patent. If you do not furnish the requested information, the U.S. Patent and Trademark Office may not be able to process and/or examine your submission, which may result in termination of proceedings or abandonment of the application or expiration of the patent.

The information provided by you in this form will be subject to the following routine uses:

1. The information on this form will be treated confidentially to the extent allowed under the Freedom of Information Act (5 U.S.C. 552) and the Privacy Act (5 U.S.C. 552a). Records from this system of records may be disclosed to the Department of Justice to determine whether disclosure of these records is required by the Freedom of Information Act.
2. A record from this system of records may be disclosed, as a routine use, in the course of presenting evidence to a court, magistrate, or administrative tribunal, including disclosures to opposing counsel in the course of settlement negotiations.
3. A record in this system of records may be disclosed, as a routine use, to a Member of Congress submitting a request involving an individual, to whom the record pertains, when the individual has requested assistance from the Member with respect to the subject matter of the record.
4. A record in this system of records may be disclosed, as a routine use, to a contractor of the Agency having need for the information in order to perform a contract. Recipients of information shall be required to comply with the requirements of the Privacy Act of 1974, as amended, pursuant to 5 U.S.C. 552a(m).
5. A record related to an International Application filed under the Patent Cooperation Treaty in this system of records may be disclosed, as a routine use, to the International Bureau of the World Intellectual Property Organization, pursuant to the Patent Cooperation Treaty.
6. A record in this system of records may be disclosed, as a routine use, to another federal agency for purposes of National Security review (35 U.S.C. 181) and for review pursuant to the Atomic Energy Act (42 U.S.C. 218(c)).
7. A record from this system of records may be disclosed, as a routine use, to the Administrator, General Services, or his/her designee, during an inspection of records conducted by GSA as part of that agency's responsibility to recommend improvements in records management practices and programs, under authority of 44 U.S.C. 2904 and 2906. Such disclosure shall be made in accordance with the GSA regulations governing inspection of records for this purpose, and any other relevant (i.e., GSA or Commerce) directive. Such disclosure shall not be used to make determinations about individuals.
8. A record from this system of records may be disclosed, as a routine use, to the public after either publication of the application pursuant to 35 U.S.C. 122(b) or issuance of a patent pursuant to 35 U.S.C. 151. Further, a record may be disclosed, subject to the limitations of 37 CFR 1.14, as a routine use, to the public if the record was filed in an application which became abandoned or in which the proceedings were terminated and which application is referenced by either a published application, an application open to public inspection or an issued patent.
9. A record from this system of records may be disclosed, as a routine use, to a Federal, State, or local law enforcement agency, if the USPTO becomes aware of a violation or potential violation of law or regulation.

Notice of Allowability	Application No. 14/764,087	Applicant(s) ESBECH ET AL.	
	Examiner KEVIN PYO	Art Unit 2878	AIA (First Inventor to File) Status No

-- The MAILING DATE of this communication appears on the cover sheet with the correspondence address--
All claims being allowable, PROSECUTION ON THE MERITS IS (OR REMAINS) CLOSED in this application. If not included herewith (or previously mailed), a Notice of Allowance (PTOL-85) or other appropriate communication will be mailed in due course. **THIS NOTICE OF ALLOWABILITY IS NOT A GRANT OF PATENT RIGHTS.** This application is subject to withdrawal from issue at the initiative of the Office or upon petition by the applicant. See 37 CFR 1.313 and MPEP 1308.

1. This communication is responsive to the amendment filed on 11/17/2017.
 A declaration(s)/affidavit(s) under **37 CFR 1.130(b)** was/were filed on _____.
2. An election was made by the applicant in response to a restriction requirement set forth during the interview on _____; the restriction requirement and election have been incorporated into this action.
3. The allowed claim(s) is/are 1,2,4-12,15-24 and 26-39. As a result of the allowed claim(s), you may be eligible to benefit from the **Patent Prosecution Highway** program at a participating intellectual property office for the corresponding application. For more information, please see http://www.uspto.gov/patents/init_events/pph/index.jsp or send an inquiry to PPHfeedback@uspto.gov.
4. Acknowledgment is made of a claim for foreign priority under 35 U.S.C. § 119(a)-(d) or (f).

Certified copies:

- a) All b) Some *c) None of the:
 1. Certified copies of the priority documents have been received.
 2. Certified copies of the priority documents have been received in Application No. _____ .
 3. Copies of the certified copies of the priority documents have been received in this national stage application from the International Bureau (PCT Rule 17.2(a)).

* Certified copies not received: _____.

Applicant has **THREE MONTHS FROM THE "MAILING DATE"** of this communication to file a reply complying with the requirements noted below. Failure to timely comply will result in **ABANDONMENT** of this application.
THIS THREE-MONTH PERIOD IS NOT EXTENDABLE.

5. **CORRECTED DRAWINGS** (as "replacement sheets") must be submitted.
 including changes required by the attached Examiner's Amendment / Comment or in the Office action of Paper No./Mail Date _____.
Identifying indicia such as the application number (see 37 CFR 1.84(c)) should be written on the drawings in the front (not the back) of each sheet. Replacement sheet(s) should be labeled as such in the header according to 37 CFR 1.121(d).
6. **DEPOSIT OF and/or INFORMATION** about the deposit of **BIOLOGICAL MATERIAL** must be submitted. Note the attached Examiner's comment regarding **REQUIREMENT FOR THE DEPOSIT OF BIOLOGICAL MATERIAL.**

Attachment(s)

- | | |
|---|---|
| <ol style="list-style-type: none"> 1. <input type="checkbox"/> Notice of References Cited (PTO-892) 2. <input type="checkbox"/> Information Disclosure Statements (PTO/SB/08),
Paper No./Mail Date _____ 3. <input type="checkbox"/> Examiner's Comment Regarding Requirement for Deposit of Biological Material 4. <input type="checkbox"/> Interview Summary (PTO-413),
Paper No./Mail Date _____ . | <ol style="list-style-type: none"> 5. <input checked="" type="checkbox"/> Examiner's Amendment/Comment 6. <input checked="" type="checkbox"/> Examiner's Statement of Reasons for Allowance 7. <input type="checkbox"/> Other _____. |
|---|---|

1. The present application is being examined under the pre-AIA first to invent provisions.

EXAMINER'S AMENDMENT

2. An examiner's amendment to the record appears below. Should the changes and/or additions be unacceptable to applicant, an amendment may be filed as provided by 37 CFR 1.312. To ensure consideration of such an amendment, it MUST be submitted no later than the payment of the issue fee.

Authorization for this examiner's amendment was given in an interview with Mr. Travis Boone on 12/12/2017.

The application has been amended as follows in view of expediting the allowance:

IN THE CLAIMS:

- (1) Claim 25 is canceled.

Allowable Subject Matter

3. Claims 1-2, 4-12, 15-24 and 26-39 are allowed.
4. The following is an examiner's statement of reasons for allowance:

Regarding claims 1-2, 4-12, 15-24 and 26-39, the prior art fails to disclose or make obvious a focus scanner for recording surface geometry and surface color of an object comprising, in addition to the other recited features of the claim, the details and functions of a multichromatic light source, a color image sensor, a data processing system in the manner recited in claim 1, 33, 35, 36 or 38.

5. Any comments considered necessary by applicant must be submitted no later than the payment of the issue fee and, to avoid processing delays, should preferably accompany the issue fee. Such submissions should be clearly labeled “Comments on Statement of Reasons for Allowance.”

Any inquiry concerning this communication or earlier communications from the examiner should be directed to KEVIN PYO whose telephone number is (571)272-2445. The examiner can normally be reached on Mon-Fri (with flexible hour), First Mon. off.

Examiner interviews are available via telephone, in-person, and video conferencing using a USPTO supplied web-based collaboration tool. To schedule an interview, applicant is encouraged to use the USPTO Automated Interview Request (AIR) at <http://www.uspto.gov/interviewpractice>.

If attempts to reach the examiner by telephone are unsuccessful, the examiner’s supervisor, Georgia Y. Epps can be reached on (571) 272-2328. The fax phone number for the organization where this application or proceeding is assigned is 571-273-8300.

Information regarding the status of an application may be obtained from the Patent Application Information Retrieval (PAIR) system. Status information for published applications may be obtained from either Private PAIR or Public PAIR. Status information for unpublished applications is available through Private PAIR only. For more information about the PAIR system, see <http://pair-direct.uspto.gov>. Should you have questions on access to the Private PAIR system, contact the Electronic Business Center (EBC) at 866-217-9197 (toll-free).

Application/Control Number: 14/764,087

Page 4

Art Unit: 2878

If you would like assistance from a USPTO Customer Service Representative or access to the automated information system, call 800-786-9199 (IN USA OR CANADA) or 571-272-1000.

/KEVIN PYO/

Primary Examiner, Art Unit 2878

EAST Search History

EAST Search History (Prior Art)

Ref #	Hits	Search Query	DBs	Default Operator	Plurals	Time Stamp
L1	43372	focus\$3 near3 scan\$4	US-PGPUB; USPAT; USOCR; FPRS; EPO; JPO; DERWENT; IBM_TDB	OR	OFF	2017/12/16 22:02
L2	200467	surface near3 color	US-PGPUB; USPAT; USOCR; FPRS; EPO; JPO; DERWENT; IBM_TDB	OR	ON	2017/12/16 22:02
L3	63720	surface near3 (geometry or topography)	US-PGPUB; USPAT; USOCR; FPRS; EPO; JPO; DERWENT; IBM_TDB	OR	ON	2017/12/16 22:02
L4	2494	L2 and L3	US-PGPUB; USPAT; USOCR; FPRS; EPO; JPO; DERWENT; IBM_TDB	OR	ON	2017/12/16 22:02
L5	85	L1 and L4	US-PGPUB; USPAT; USOCR; FPRS; EPO; JPO; DERWENT; IBM_TDB	OR	ON	2017/12/16 22:02
L6	547875	color near2 imag\$3	US-PGPUB; USPAT; USOCR; FPRS; EPO; JPO; DERWENT; IBM_TDB	OR	ON	2017/12/16 22:03
L7	5925	multi near2 (chromatic or color) near2 light	US-PGPUB; USPAT; USOCR; FPRS; EPO; JPO; DERWENT; IBM_TDB	OR	ON	2017/12/16 22:05
L8	1197	6 and 7	US-PGPUB; USPAT; USOCR; FPRS; EPO; JPO; DERWENT; IBM_TDB	OR	ON	2017/12/16 22:05
L9	15	1 and 8	US-PGPUB; USPAT; USOCR; FPRS; EPO; JPO; DERWENT; IBM_TDB	OR	ON	2017/12/16 22:05
L10	2698	348/47.ccls.	US-PGPUB; USPAT; USOCR; FPRS; EPO; JPO; DERWENT; IBM_TDB	OR	ON	2017/12/16 23:08
L11	2549	250/234.ccls.	US-PGPUB; USPAT; USOCR; FPRS; EPO; JPO; DERWENT; IBM_TDB	OR	ON	2017/12/16 23:08
L12	3660	250/226.ccls.	US-PGPUB; USPAT; USOCR; FPRS; EPO; JPO; DERWENT; IBM_TDB	OR	ON	2017/12/16 23:08
L13	12865	G01B11/24.cpc.	US-PGPUB; USPAT; USOCR; FPRS; EPO; JPO; DERWENT; IBM_TDB	OR	ON	2017/12/16 23:08
L14	856	G01B11/2509.cpc.	US-PGPUB; USPAT; USOCR; FPRS; EPO; JPO; DERWENT; IBM_TDB	OR	ON	2017/12/16 23:08
L15	1839	G01B11/2518.cpc.	US-PGPUB; USPAT; USOCR; FPRS; EPO; JPO; DERWENT; IBM_TDB	OR	ON	2017/12/16 23:08
L16	970	G01J3/508.cpc.	US-PGPUB; USPAT; USOCR; FPRS; EPO; JPO; DERWENT;	OR	ON	2017/12/16 23:08

EAST Search History

			IBM_TDB			
L17	24868	L10 L11 L12 L13 L14 L15 L16	US-PGPUB; USPAT; USOCR; FPRS; EPO; JPO; DERWENT; IBM_TDB	OR	ON	2017/12/16 23:08
L18	83	17 and 4	US-PGPUB; USPAT; USOCR; FPRS; EPO; JPO; DERWENT; IBM_TDB	OR	ON	2017/12/16 23:08
L19	40	6 and 18	US-PGPUB; USPAT; USOCR; FPRS; EPO; JPO; DERWENT; IBM_TDB	OR	ON	2017/12/16 23:08

EAST Search History (Interference)

Ref #	Hits	Search Query	DBs	Default Operator	Plurals	Time Stamp
L20	2931	(focus\$3 near3 scan\$4).dm.	USPAT	OR	OFF	2017/12/16 23:20
L21	30446	(color near2 imag\$3).clm.	USPAT	OR	ON	2017/12/16 23:20
L22	93	20 and 21	USPAT	OR	ON	2017/12/16 23:20
L23	273	(multi near2 (chromatic or color) near2 light).clm.	USPAT	OR	ON	2017/12/16 23:21
L24	0	22 and 23	USPAT	OR	ON	2017/12/16 23:21
L25	7696	(surface near3 color).clm.	USPAT	OR	ON	2017/12/16 23:21

12/16/2017 11:27:13 PM

C:\Users\kpyo\Documents\EAST\Workspaces\14764087.wsp

Issue Classification 	Application/Control No. 14764087	Applicant(s)/Patent Under Reexamination ESBECH ET AL.	
	Examiner KEVIN PYO	Art Unit 2878	

CPC						
Symbol					Type	Version
A61C	9			0073	F	2013-01-01
A61C	9			0066	I	2013-01-01
G01B	11			2513	I	2013-01-01
G01B	11			2518	I	2013-01-01
G01J	3			513	I	2013-01-01
G01J	3			0237	I	2013-01-01
G01J	3			0278	I	2013-01-01
G01J	3			508	I	2013-01-01
G01J	3			0208	I	2013-01-01
G01J	3			0224	I	2013-01-01
A61C	9			006	I	2013-01-01
G01B	11			2509	I	2013-01-01
G01B	11			24	I	2013-01-01
G01J	3			51	I	2013-01-01

CPC Combination Sets								
Symbol					Type	Set	Ranking	Version

NONE		Total Claims Allowed:	
(Assistant Examiner)	(Date)	35	
/KEVIN PYO/ Primary Examiner, Art Unit 2878	12/17/2017	O.G. Print Claim(s)	O.G. Print Figure
(Primary Examiner)	(Date)	1	1

Issue Classification 	Application/Control No. 14764087	Applicant(s)/Patent Under Reexamination ESBECH ET AL.
	Examiner KEVIN PYO	Art Unit 2878

<input type="checkbox"/> Claims renumbered in the same order as presented by applicant <input type="checkbox"/> CPA <input type="checkbox"/> T.D. <input type="checkbox"/> R.1.47															
Final	Original	Final	Original	Final	Original	Final	Original	Final	Original	Final	Original	Final	Original	Final	Original
1	1	14	17	29	33										
2	2	15	18	30	34										
	3	16	19	31	35										
3	4	17	20	32	36										
4	5	18	21	33	37										
5	6	19	22	34	38										
6	7	20	23	35	39										
7	8	21	24												
8	9		25												
9	10	22	26												
10	11	23	27												
11	12	24	28												
	13	25	29												
	14	26	30												
12	15	27	31												
13	16	28	32												

NONE		Total Claims Allowed:	
(Assistant Examiner)	(Date)	35	
/KEVIN PYO/ Primary Examiner.Art Unit 2878	12/17/2017	O.G. Print Claim(s)	O.G. Print Figure
(Primary Examiner)	(Date)	1	1

Search Notes 	Application/Control No. 14764087	Applicant(s)/Patent Under Reexamination ESBECH ET AL.
	Examiner KEVIN PYO	Art Unit 2878

CPC- SEARCHED		
Symbol	Date	Examiner
G01B 11/24; 11/2509; 11/2518	7/9/17	kp
Updated the above areas	12/16/17	kp

CPC COMBINATION SETS - SEARCHED		
Symbol	Date	Examiner

US CLASSIFICATION SEARCHED			
Class	Subclass	Date	Examiner
250	226; 234	7/9/17	kp
348	47	7/9/17	kp
	Updated the above areas	12/16/17	kp

* See search history printout included with this form or the SEARCH NOTES box below to determine the scope of the search.

SEARCH NOTES		
Search Notes	Date	Examiner
EAST-see search history printout	7/9/17	kp
Inventor name and assignee search	7/9/17	kp
EAST-see search history printout	12/16/17	kp
Above CPC and USPC combined with keywords	12/16/17	kp

INTERFERENCE SEARCH			
US Class/ CPC Symbol	US Subclass / CPC Group	Date	Examiner
	Interference search history printout-EAST	12/16/17	kp

--	--

UNITED STATES PATENT AND TRADEMARK OFFICE

 UNITED STATES DEPARTMENT OF COMMERCE
 United States Patent and Trademark Office
 Address: COMMISSIONER FOR PATENTS
 P.O. Box 1450
 Alexandria, Virginia 22313-1450
 www.uspto.gov

BIB DATA SHEET
CONFIRMATION NO. 6247

SERIAL NUMBER	FILING or 371(c) DATE	CLASS	GROUP ART UNIT	ATTORNEY DOCKET NO.		
14/764,087	07/28/2015	250	2878	0079124-000111		
APPLICANTS 3SHAPE A/S, Copenhagen k, DENMARK;						
INVENTORS Bo ESBECH, Gentofte, DENMARK; Christian Romer ROSBERG, Bronshoj, DENMARK; Mike VAN DER POEL, Rodovre, DENMARK; Rasmus KJAER, Kobenhavn K, DENMARK; Michael VINTHER, Kobenhavn S, DENMARK; Karl-Josef HOLLENBECK, Copenhagen O, DENMARK;						
** CONTINUING DATA ***** This application is a 371 of PCT/EP2014/052842 02/13/2014 which claims benefit of 61/764,178 02/13/2013						
** FOREIGN APPLICATIONS ***** DENMARK PA 2013 70077 02/13/2013						
** IF REQUIRED, FOREIGN FILING LICENSE GRANTED ** 10/15/2015						
Foreign Priority claimed	<input checked="" type="checkbox"/> Yes <input type="checkbox"/> No	<input type="checkbox"/> Met after Allowance	STATE OR COUNTRY	SHEETS DRAWINGS	TOTAL CLAIMS	INDEPENDENT CLAIMS
35 USC 119(a-d) conditions met	<input checked="" type="checkbox"/> Yes <input type="checkbox"/> No	Initials	DENMARK	4	31	2
Verified and Acknowledged	/KEVIN K PYO/ Examiner's Signature					
ADDRESS BUCHANAN, INGERSOLL & ROONEY PC POST OFFICE BOX 1404 ALEXANDRIA, VA 22313-1404 UNITED STATES						
TITLE FOCUS SCANNING APPARATUS RECORDING COLOR						
FILING FEE RECEIVED 5320	FEES: Authority has been given in Paper No. _____ to charge/credit DEPOSIT ACCOUNT No. _____ for following:			<input type="checkbox"/> All Fees		
				<input type="checkbox"/> 1.16 Fees (Filing)		
				<input type="checkbox"/> 1.17 Fees (Processing Ext. of time)		
				<input type="checkbox"/> 1.18 Fees (Issue)		
				<input type="checkbox"/> Other _____		
			<input type="checkbox"/> Credit			

Index of Claims 	Application/Control No. 14764087	Applicant(s)/Patent Under Reexamination ESBECH ET AL.
	Examiner KEVIN PYO	Art Unit 2878

✓	Rejected	-	Cancelled	N	Non-Elected	A	Appeal
=	Allowed	÷	Restricted	I	Interference	O	Objected

Claims renumbered in the same order as presented by applicant
 CPA
 T.D.
 R.1.47

CLAIM		DATE							
Final	Original	07/09/2017	12/16/2017						
1	1	✓	=						
2	2	✓	=						
	3	✓	-						
3	4	✓	=						
4	5	✓	=						
5	6	✓	=						
6	7	✓	=						
7	8	✓	=						
8	9	✓	=						
9	10	✓	=						
10	11	✓	=						
11	12	O	=						
	13	✓	-						
	14	O	-						
12	15	O	=						
13	16	O	=						
14	17	✓	=						
15	18	✓	=						
16	19	✓	=						
17	20	✓	=						
18	21	✓	=						
19	22	✓	=						
20	23	✓	=						
21	24	✓	=						
	25	✓	-						
22	26	✓	=						
23	27	✓	=						
24	28	✓	=						
25	29	✓	=						
26	30	✓	=						
27	31	O	=						
28	32		=						
29	33		=						
30	34		=						
31	35		=						
32	36		=						

Index of Claims 	Application/Control No. 14764087	Applicant(s)/Patent Under Reexamination ESBECH ET AL.
	Examiner KEVIN PYO	Art Unit 2878

✓	Rejected	-	Cancelled	N	Non-Elected	A	Appeal
=	Allowed	÷	Restricted	I	Interference	O	Objected

<input type="checkbox"/> Claims renumbered in the same order as presented by applicant		<input type="checkbox"/> CPA		<input type="checkbox"/> T.D.		<input type="checkbox"/> R.1.47			
CLAIM		DATE							
Final	Original	07/09/2017	12/16/2017						
33	37		=						
34	38		=						
35	39		=						



UNITED STATES PATENT AND TRADEMARK OFFICE

UNITED STATES DEPARTMENT OF COMMERCE
United States Patent and Trademark Office
Address: COMMISSIONER FOR PATENTS
P.O. Box 1450
Alexandria, Virginia 22313-1450
www.uspto.gov

Table with 5 columns: APPLICATION NO., FILING DATE, FIRST NAMED INVENTOR, ATTORNEY DOCKET NO., CONFIRMATION NO.
Row 1: 14/764,087, 07/28/2015, Bo ESBECH, 0079124-000111, 6247
Row 2: 21839, 7590, 01/05/2018, BUCHANAN, INGERSOLL & ROONEY PC, POST OFFICE BOX 1404, ALEXANDRIA, VA 22313-1404
Row 3: EXAMINER PYO, KEVIN K
Row 4: ART UNIT 2878, PAPER NUMBER
Row 5: NOTIFICATION DATE 01/05/2018, DELIVERY MODE ELECTRONIC

Please find below and/or attached an Office communication concerning this application or proceeding.

The time period for reply, if any, is set in the attached communication.

Notice of the Office communication was sent electronically on above-indicated "Notification Date" to the following e-mail address(es):

ADIPDOC1@BIPC.com



UNITED STATES PATENT AND TRADEMARK OFFICE

Commissioner for Patents
United States Patent and Trademark Office
P. O. Box 1450
Alexandria, VA 22313-1450
www.uspto.gov

Application No. : 14764087
Applicant : Esbech
Filing Date : 07/28/2015
Date Mailed : 01/05/2018

NOTICE TO FILE CORRECTED APPLICATION PAPERS

Notice of Allowance Mailed

This application has been accorded an Allowance Date and is being prepared for issuance. The application, however, is incomplete for the reasons below.

Applicant is given two (2) months from the mail date of this Notice within which to respond. This time period for reply is extendable under 37 CFR 1.136(a) for only TWO additional MONTHS.

The informalities requiring correction are indicated in the attachment(s). If the informality pertains to the abstract, specification (including claims) or drawings, the informality must be corrected with an amendment in compliance with 37 CFR 1.121 (or, if the application is a reissue application, 37 CFR 1.173). Such an amendment may be filed after payment of the issue fee if limited to correction of informalities noted herein. See Waiver of 37 CFR 1.312 for Documents Required by the Office of Patent Publication, 1280 Off. Gaz. Patent Office 918 (March 23, 2004). In addition, if the informality is not corrected until after payment of the issue fee, for purposes of 35 U.S.C. 154(b)(1)(iv), "all outstanding requirements" will be considered to have been satisfied when the informality has been corrected. A failure to respond within the above-identified time period will result in the application being ABANDONED.

See attachment(s).

*A copy of this notice **MUST** be returned with the reply. Please address response to
"Mail Stop Issue Fee, Commissioner for Patents,
P.O. Box 1450, Alexandria, VA 22313-1450".*

/Midel Geronimo/
Publication Branch
Office of Data Management
(571) 272-4200

Application No. 14764087

SPECIFICATION NOT IN COMPLIANCE WITH 37 CFR 1.52(b)(5)

The pages of the specification document coded SPEC dated 07/28/2015 have not been numbered. Per 37 CFR 1.52(b)(5), “the pages of the specification including claims and abstract must be numbered consecutively, beginning with 1, the numbers being centrally located above or preferably below, the text.” In response to this notice, the applicant must submit a substitute specification in which the pages are so numbered.

NOTE: Although 37 CFR 1.52(b)(5) refers to page numbering for “the specification including claims and abstract,” any abstract or claims submitted in response to this notice will not be entered. Only the substitute specification, and any amendment thereto entered during prosecution, will be entered.

IN THE UNITED STATES PATENT AND TRADEMARK OFFICE

In re Patent Application of)	Group Art Unit: 2878
)	
Bo ESBECH et al.)	Confirmation No.: 6247
)	
Application No.: 14/764,087)	
)	
Filed: July 28, 2015)	
)	
For: FOCUS SCANNING APPARATUS RECORDING)	
COLOR)	

37 CFR 1.312 AMENDMENT

Commissioner for Patents
P.O. Box 1450
Alexandria, VA 22313-1450

Commissioner:

In response to the Notice to File Corrected Application Papers of January 5, 2018, kindly
amend the application as follows.

AMENDMENTS TO THE SPECIFICATION:

Please replace the specification with the attached substitute specification that includes page numbers.

No new matter has been added.

REMARKS

The Notice to file Corrected Application Papers requests a Specification be submitted that includes page numbering. Accordingly, the attached specification includes page numbers.

No other changes have been made.

Should any questions arise in connection with this application, it is respectfully requested that the undersigned be contacted at the number indicated below.

Respectfully submitted,

BUCHANAN INGERSOLL & ROONEY PC

Date: 10 January 2018

By: /Travis D. Boone/
Travis D. Boone
Registration No. 52635

Customer No. 21839
(703) 836-6620

FOCUS SCANNING APPARATUS RECORDING COLOR

Field of the application

- 5 The application relates to three dimensional (3D) scanning of the surface geometry and surface color of objects. A particular application is within dentistry, particularly for intraoral scanning.

Background

10

3D scanners are widely known from the art, and so are intraoral dental 3D scanners (e.g., Sirona Cerec, Cadent Itero, 3Shape TRIOS).

15 The ability to record surface color is useful in many applications. For example in dentistry, the user can differentiate types of tissue or detect existing restorations. For example in materials inspection, the user can detect surface abnormalities such as crystallization defects or discoloring. None of the above is generally possible from surface geometry information alone.

20 WO2010145669 mentions the possibility of recording color. In particular, several sequential images, each taken for an illumination in a different color - typically blue, green, and red - are combined to form a synthetic color image. This approach hence requires means to change light source color, such as color filters. Furthermore, in handheld use, the scanner will move relative to the scanned object
25 during the illumination sequence, reducing the quality of the synthetic color image.

Also US7698068 and US8102538 (Cadent Inc.) describe an intraoral scanner that records both geometry data and texture data with one or more image sensor(s). However, there is a slight delay between the color and the geometry recording,
30 respectively. US7698068 requires sequential illumination in different colors to form a synthetic image, while US8102538 mentions white light as a possibility, however

from a second illumination source or recorded by a second image sensor, the first set being used for recording the geometry.

WO2012083967 discloses a scanner for recording geometry data and texture data with two separate cameras. While the first camera has a relatively shallow depth of field as to provide focus scanning based on multiple images, the second camera
5 has a relatively large depth of field as to provide color texture information from a single image.

Color-recording scanning confocal microscopes are also known from the prior art
10 (e.g., Keyence VK9700; see also JP2004029373). A white light illumination system along with a color image sensor is used for recording 2D texture, while a laser beam forms a dot that is scanned, i.e., moved over the surface and recorded by a photomultiplier, providing the geometry data from many depth measurements, one for each position of the dot. The principle of a moving dot requires the measured
15 object not to move relative to the microscope during measurement, and hence is not suitable for handheld use.

Summary

20 One aspect of this application is to provide a scanner system and a method for recording surface geometry and surface color of an object, and where surface geometry and surface color are derived from the same captured 2D images.

One aspect of this application is to provide a scanner system for recording surface
25 geometry and surface color of an object, and wherein all 2D images are captured using the same color image sensor.

One aspect of this application is to provide a scanner system and a method for recording surface geometry and surface color of an object, in which the information
30 relating to the surface geometry and to the surface color are acquired simultaneously such that an alignment of data relating to the recorded surface

geometry and data relating to the recorded surface color is not required in order to generate a digital 3D representation of the object expressing both color and geometry of the object.

- 5 Disclosed is a scanner system for recording surface geometry and surface color of an object, the scanner system comprising:
- a multichromatic light source configured for providing a multichromatic probe light for illumination of the object,
 - a color image sensor comprising an array of image sensor pixels for capturing
 - 10 one or more 2D images of light received from said object, and
 - a data processing system configured for deriving both surface geometry information and surface color information for a block of said image sensor pixels at least partly from one 2D image recorded by said color image sensor.

- 15 Disclosed is a method of recording surface geometry and surface color of an object, the method comprising:
- obtaining a scanner system comprising a multichromatic light source and a color image sensor comprising an array of image sensor pixels;
 - illuminating the surface of said object with multichromatic probe light from said
 - 20 multichromatic light source;
 - capturing a series of 2D images of said object using said color image sensor; and
 - deriving both surface geometry information and surface color information for a block of said image sensor pixels at least partly from one captured 2D image.

25 In the context of the present application, the phrase "surface color" may refer to the apparent color of an object surface and thus in some cases, such as for semi-transparent or semi-translucent objects such as teeth, be caused by light from the object surface and/or the material below the object surface, such as material

30 immediately below the object surface.

In the context of the present application, the phrase “derived at least partly from one 2D image” refers to the situation where the surface geometry information for a given block of image sensor pixels at least in part is derived from one 2D image and where the corresponding surface color information at least in part is derived from the same 2D image. The phrase also covers cases where the surface geometry information for a given block of image sensor pixels at least in part is derived from a plurality of 2D images of a series of captured 2D images and where the corresponding surface color information at least in part is derived from the same 2D images of that series of captured 2D images.

10

An advantage of deriving both surface geometry information and surface color information for a block of said image sensor pixels at least partly from one 2D image is that a scanner system having only one image sensor can be realized.

15

It is an advantage that the surface geometry information and the surface color information are derived at least partly from one 2D image, since this inherently provides that the two types of information are acquired simultaneously. There is hence no requirement for an exact timing of the operation of two color image sensors, which may be the case when one image sensor is used for the geometry recording and another for color recording. Equally there is no need for an elaborate calculation accounting for significant differences in the timing of capturing of 2D images from which the surface geometry information is derived and the timing of the capturing of 2D images from which the surface color information is derived.

20

25

The present application discloses a significant improvement over the state of the art in that only a single image sensor and a single multichromatic light source is required, and that surface color and surface geometry for at least a part of the object can be derived from the same 2D image or 2D images, which also means that alignment of color and surface geometry is inherently perfect. In the scanner system according to the present application, there is no need for taking into account or compensating for relative motion of the object and scanner system between

30

obtaining surface geometry and surface color. Since the surface geometry and the surface color are obtained at precisely the same time, the scanner system automatically maintains its spatial disposition with respect to the object surface while obtaining the surface geometry and the surface color. This makes the scanner system of the present application suitable for handheld use, for example as an
5 intraoral scanner, or for scanning moving objects.

In some embodiments, the data processing system is configured for deriving surface geometry information and surface color information for said block of image
10 sensor pixels from a series of 2D images, such as from a plurality of the 2D images in a series of captured 2D images. I.e. the data processing system is capable of analyzing a plurality of the 2D images in a series of captured 2D images in order to derive the surface geometry information for a block of image sensor pixels and to also derive surface color information from at least one of the 2D images from which
15 the surface geometry information is derived.

In some embodiments, the data processing system is configured for deriving surface color information from a plurality of 2D images of a series of captured 2D images and for deriving surface geometry information from at least one of the 2D
20 images from which the surface color information is derived.

In some embodiments, the data processing system is configured for deriving surface geometry information from a plurality of 2D images of a series of captured 2D images and for deriving surface color information from at least one of the 2D
25 images from which the surface geometry information is derived.

In some embodiments, the set of 2D images from which surface color information is derived from is identical to the set of 2D images from which surface geometry information is derived from.

30

In some embodiments, the data processing system is configured for generating a sub-scan of a part of the object surface based on surface geometry information and surface color information derived from a plurality of blocks of image sensor pixels. The sub-scan expresses at least the geometry of the part of the object and typically one sub-scan is derived from one stack of captured 2D images.

In some embodiments, all 2D images of a captured series of images are analyzed to derive the surface geometry information for each block of image sensor pixels on the color image sensor.

For a given block of image sensor pixels the corresponding portions of the captured 2D images in the stack may be analyzed to derive the surface geometry information and surface color information for that block.

In some embodiments, the surface geometry information relates to where the object surface is located relative to the scanner system coordinate system for that particular block of image sensor pixels.

One advantage of the scanner system and the method of the current application is that the informations used for generating the sub-scan expressing both geometry and color of the object (as seen from one view) are obtained concurrently.

Sub-scans can be generated for a number of different views of the object such that they together cover the part of the surface.

In some embodiments, the data processing system is configured for combining a number of sub-scans to generate a digital 3D representation of the object. The digital 3D representation of the object then preferably expresses both the recorded geometry and color of the object.

The digital 3D representation of the object can be in the form of a data file. When the object is a patient's set of teeth the digital 3D representation of this set of teeth can e.g. be used for CAD/CAM manufacture of a physical model of the patient's set teeth.

5

The surface geometry and the surface color are both determined from light recorded by the color image sensor.

In some embodiments, the light received from the object originates from the multichromatic light source, i.e. it is probe light reflected or scattered from the surface of the object.

In some embodiments, the light received from the object comprises fluorescence excited by the probe light from the multichromatic light source, i.e. fluorescence emitted by fluorescent materials in the object surface.

In some embodiments, a second light source is used for the excitation of fluorescence while the multichromatic light source provides the light for obtaining the geometry and color of the object.

20

The scanner system preferably comprises an optical system configured for guiding light emitted by the multichromatic light source towards the object to be scanned and for guiding light received from the object to the color image sensor such that the 2D images of said object can be captured by said color image sensor.

25

In some embodiments, the scanner system comprises a first optical system, such as an arrangement of lenses, for transmitting the probe light from the multichromatic light source towards an object and a second optical system for imaging light received from the object at the color image sensor.

30

In some embodiments, single optical system images the probe light onto the object and images the object, or at least a part of the object, onto the color image sensor, preferably along the same optical axis, however in opposite directions along optical axis. The scanner may comprise at least one beam splitter located in the optical path, where the beam splitter is arranged such that it directs the probe light from the multichromatic light source towards the object while it directs light received from the object towards the color image sensor.

Several scanning principles are suitable, such as triangulation and focus scanning.

In some embodiments, the scanner system is a focus scanner system operating by translating a focus plane along an optical axis of the scanner system and capturing the 2D images at different focus plane positions such that each series of captured 2D images forms a stack of 2D images. The focus plane position is preferably shifted along an optical axis of the scanner system, such that 2D images captured at a number of focus plane positions along the optical axis forms said stack of 2D images for a given view of the object, i.e. for a given arrangement of the scanner system relative to the object. After changing the arrangement of the scanner system relative to the object a new stack of 2D images for that view can be captured. The focus plane position may be varied by means of at least one focus element, e.g., a moving focus lens.

In some focus scanner embodiments, the scanner system comprises a pattern generating element configured for incorporating a spatial pattern in said probe light.

In some embodiments, the pattern generating element is configured to provide that the probe light projected by scanner system onto the object comprises a pattern consisting of dark sections and sections with light having the a wavelength distribution according to the wavelength distribution of the multichromatic light source.

In some embodiments, the multichromatic light source comprises a broadband light source, such as a white light source

5 In some embodiments, the pixels of the color image sensor and the pattern generating element are configured to provide that each pixel corresponds to a single bright or dark region of the spatial pattern incorporated in said probe light.

10 For a focus scanner system the surface geometry information for a given block of image sensor pixels is derived by identifying at which distance from the scanner system the object surface is in focus for that block of image sensor pixels.

15 In some embodiments, deriving the surface geometry information and surface color information comprises calculating for several 2D images, such as for several 2D images in a captured stack of 2D images, a correlation measure between the portion of the 2D image captured by said block of image sensor pixels and a weight function. Here the weight function is preferably determined based on information of the configuration of the spatial pattern. The correlation measure may be calculated for each 2D image of the stack.

20 The scanner system may comprise means for evaluating a correlation measure at each focus plane position between at least one image pixel and a weight function, where the weight function is determined based on information of the configuration of the spatial pattern.

25 In some embodiments, deriving the surface geometry information and the surface color information for a block of image sensor pixels comprises identifying the position along the optical axis at which the corresponding correlation measure has a maximum value. The position along the optical axis at which the corresponding correlation measure has a maximum value may coincide with the position where a
30 2D image has been captured but it may even more likely be in between two neighboring 2D images of the stack of 2D images.

Determining the surface geometry information may then relate to calculating a correlation measure of the spatially structured light signal provided by the pattern with the variation of the pattern itself (which we term reference) for every location of the focus plane and finding the location of an extremum of this stack of 2D images. In some embodiments, the pattern is static. Such a static pattern can for example be realized as a chrome-on-glass pattern.

One way to define the correlation measure mathematically with a discrete set of measurements is as a dot product computed from a signal vector, $\mathbf{I} = (I_1, \dots, I_n)$, with $n > 1$ elements representing sensor signals and a reference vector, $\mathbf{f} = (f_1, \dots, f_n)$, of reference weights. The correlation measure A is then given by

$$A = \mathbf{f} \cdot \mathbf{I} = \sum_{i=1}^n f_i I_i$$

The indices on the elements in the signal vector represent sensor signals that are recorded at different pixels, typically in a block of pixels. The reference vector \mathbf{f} can be obtained in a calibration step.

By using knowledge of the optical system used in the scanner, it is possible to transform the location of an extremum of the correlation measure, i.e., the focus plane into depth data information, on a pixel block basis. All pixel blocks combined thus provide an array of depth data. In other words, depth is along an optical path that is known from the optical design and/or found from calibration, and each block of pixels on the image sensor represents the end point of an optical path. Therefore, depth along an optical path, for a bundle of paths, yields a surface geometry within the field of view of the scanner, i.e. a sub-scan for the present view.

It can be advantageous to smooth and interpolate the series of correlation measure values, such as to obtain a more robust and accurate determination of the location of the maximum.

In some embodiments, the generating a sub-scan comprises determining a correlation measure function describing the variation of the correlation measure along the optical axis for each block of image sensor pixels and identifying for the position along the optical axis at which the correlation measure functions have their maximum value for the block.

In some embodiments, the maximum correlation measure value is the highest calculated correlation measure value for the block of image sensor pixels and/or the highest maximum value of the correlation measure function for the block of image sensor pixels.

For example, a polynomial can be fitted to the values of A for a pixel block over several images on both sides of the recorded maximum, and a location of a deducted maximum can be found from the maximum of the fitted polynomial, which can be in between two images. The deducted maximum is subsequently used as depth data information when deriving the surface geometry from the present view, i.e. when deriving a sub-scan for the view.

In some embodiments, the data processing system is configured for determining a color for a point on a generated sub-scan based on the surface color information of the 2D image of the series in which the correlation measure has its maximum value for the corresponding block of image sensor pixels. The color may e.g. be read as the RGB values for pixels in said block of image sensor pixels.

In some embodiments, the data processing system is configured for deriving the color for a point on a generated sub-scan based on the surface color informations of the 2D images in the series in which the correlation measure has its maximum value for the corresponding block of image sensor pixels and on at least one additional 2D image, such as a neighboring 2D image from the series of captured 2D images. The surface color information is still derived from at least one of the 2D images from which the surface geometry information is derived.

In some embodiments, the data processing system is configured for interpolating surface color information of at least two 2D images in a series when determining the sub-scan color, such as an interpolation of surface color information of neighboring
5 2D images in a series.

In some embodiments, the data processing system is configured for computing a smoothed color for a number of points of the sub-scan, where the computing comprises an averaging of sub-scan colors of different points, such as a weighted
10 averaging of the colors of the surrounding points on the sub-scan.

Surface color information for a block of image sensor pixels is at least partially derived from the same image from which surface geometry information is derived. In case the location of the maximum of A is represented by a 2D image, then also
15 color is derived from that same image. In case the location of the maximum of A is found by interpolation to be between two images, then at least one of those two images should be used to derive color, or both images using interpolation for color also. It is also possible to average color data from more than two images used in the determination of the location of the maximum of the correlation measure, or to
20 average color from a subset or superset of multiple images used to derive surface geometry. In any case, some image sensor pixels readings are used to derive both surface color and surface geometry for at least a part of the scanned object.

Typically, there are three color filters, so the overall color is composed of three
25 contributions, such as red, green, and blue, or cyan, magenta, and yellow. Note that color filters typically allow a range of wavelengths to pass, and there is typically cross-talk between filters, such that, for example, some green light will contribute to the intensity measured in pixels with red filters.

30 For an image sensor with a color filter array, a color component c_i within a pixel block can be obtained as

$$c_j = \sum_{i=1}^n g_{j,i} I_i$$

where $g_{j,i} = 1$ if pixel i has a filter for color c_j , 0 otherwise. For an RGB filter array like in a Bayer pattern, j is one of red, green, or blue. Further weighting of the individual color components, i.e., color calibration, may be required to obtain natural color data, typically as compensation for varying filter efficiency, illumination source efficiency, and different fraction of color components in the filter pattern. The calibration may also depend on focus plane location and/or position within the field of view, as the mixing of the light source component colors may vary with those factors.

10 In some embodiments, surface color information is obtained for every pixel in a pixel block. In color image sensors with a color filter array or with other means to separate colors such as diffractive means, depending on the color measured with a particular pixel, an intensity value for that color is obtained. In other words, in this case a particular pixel has a color value only for one color. Recently developed
15 color image sensors allow measurement of several colors in the same pixel, at different depths in the substrate, so in that case, a particular pixel can yield intensity values for several colors. In summary, it is possible to obtain a resolution of the surface color data that is inherently higher than that of the surface geometry information.

20 In the embodiments where the resolution of the derived color is higher than the resolution of the surface geometry for the generated digital 3D representation of the object, a pattern will be visible when at least approximately in focus, which preferably is the case when color is derived. The image can be filtered such as to
25 visually remove the pattern, however at a loss of resolution. In fact, it can be advantageous to be able to see the pattern for the user. For example in intraoral scanning, it may be important to detect the position of a margin line, the rim or edge of a preparation. The image of the pattern overlaid on the geometry of this edge is sharper on a side that is seen approximately perpendicular, and more blurred on the

side that is seen at an acute angle. Thus, a user, who in this example typically is a dentist or dental technician, can use the difference in sharpness to more precisely locate the position of the margin line than may be possible from examining the surface geometry alone.

5

High spatial contrast of an in-focus pattern image on the object is desirable to obtain a good signal to noise ratio of the correlation measure on the color image sensor. Improved spatial contrast can be achieved by preferential imaging of the specular surface reflection from the object on the color image sensor. Thus, some

10 embodiments comprise means for preferential/selective imaging of specularly reflected light. This may be provided if the scanner further comprises means for polarizing the probe light, for example by means of at least one polarizing beam splitter.

15 In some embodiments, the polarizing optics is coated such as to optimize preservation of the circular polarization of a part of the spectrum of the multichromatic light source that is used for recording the surface geometry.

The scanner system may further comprise means for changing the polarization

20 state of the probe light and/or the light received from the object. This can be provided by means of a retardation plate, preferably located in the optical path. In some embodiments, the retardation plate is a quarter wave retardation plate.

Especially for intraoral applications where the scanned object e.g. is the patient's

25 set or teeth, the scanner can have an elongated tip, with means for directing the probe light and/or imaging an object. This may be provided by means of at least one folding element. The folding element could be a light reflecting element such as a mirror or a prism. The probe light then emerges from the scanner system along an optical axis at least partly defined by the folding element.

30

For a more in-depth description of the focus scanning technology, see WO2010145669.

5 In some embodiments, the data processing system is configured for determining the color of a least one point of the generated digital 3D representation of the object, such that the digital 3D representation expresses both geometry and color profile of the object. Color may be determined for several points of the generated digital 3D representation such that the color profile of the scanned part of the object is expressed by the digital 3D representation.

10

In some embodiments determining the object color comprises computing a weighted average of color values derived for corresponding points in overlapping sub-scans at that point of the object surface. This weighted average can then be used as the color of the point in the digital 3D representation of the object.

15

In some embodiments the data processing system is configured for detecting saturated pixels in the captured 2D images and for mitigating or removing the error in the derived surface color information or the sub-scan color caused by the pixel saturation.

20

In some embodiments the error caused by the saturated pixel is mitigated or removed by assigning a low weight to the surface color information of the saturated pixel in the computing of the smoothed color of a sub-scan and/or by assigning a low weight to the color of a sub-scan computed based on the saturated pixel.

25

In some embodiments, the data processing system is configured for comparing the derived surface color information of sections of the captured 2D images and/or of the generated sub-scans of the object with predetermined color ranges for teeth and for oral tissue, and for suppressing the red component of the derived surface color
30 information or sub-scan color for sections where the color is not in one of the two predetermined color ranges.

The scanner system disclosed here comprises a multichromatic light source, for example a white light source, for example a multi-die LED.

5 Light received from the scanned object, such as probe light returned from the object surface or fluorescence generated by the probe light by exciting fluorescent parts of the object, is recorded by the color image sensor. In some embodiments, the color image sensor comprises a color filter array such that every pixel in the color image sensor is a color-specific filter. The color filters are preferably arranged in a regular pattern, for example where the color filters are arranged according to a Bayer color
10 filter pattern. The image data thus obtained are used to derive both surface geometry and surface color for each block of pixels. For a focus scanner utilizing a correlation measure, the surface geometry may be found from an extremum of the correlation measure as described above.

15 In some embodiments, the surface geometry is derived from light in a first part of the spectrum of the probe light provided by the multichromatic light source.

Preferably, the color filters are aligned with the image sensor pixels, preferably such that each pixel has a color filter for a particular color only.

20

In some embodiments, the color filter array is such that its proportion of pixels with color filters that match the first part of the spectrum is larger than 50%.

25 In some embodiments, the surface geometry information is derived from light in a selected wavelength range of the spectrum provided by the multichromatic light source. The light in the other wavelength ranges is hence not used to derive the surface geometry information. This provides the advantage that chromatic dispersion of optical elements in the optical system of the scanner system does not influence the scanning of the object.

30

It can be preferable to compute the surface geometry only from pixels with one or two types of color filters. A single color requires no achromatic optics and is thus provides for a scanner that is easier and cheaper to build. Furthermore, folding elements can generally not preserve the polarization state for all colors equally well.

5 When only some color(s) is/are used to compute surface geometry, the reference vector f will contain zeros for the pixels with filters for the other color(s). Accordingly, the total signal strength is generally reduced, but for large enough blocks of pixels, it is generally still sufficient. Preferentially, the pixel color filters are adapted for little cross-talk from one color to the other(s). Note that even in the embodiments
10 computing geometry from only a subset of pixels, color is preferably still computed from all pixels.

In some embodiments, the color image sensor comprises a color filter array comprising at least three types of colors filters, each allowing light in a known
15 wavelength range, $W1$, $W2$, and $W3$ respectively, to propagate through the color filter.

In some embodiments, the color filter array is such that its proportion of pixels with color filters that match the selected wavelength range of the spectrum is larger than
20 50%, such a wherein the proportion equals 32/36, 60/64 or 96/100.

In some embodiments, the selected wavelength range matches the $W2$ wavelength range.

25 In some embodiments, the color filter array comprises a plurality of cells of 6x6 color filters, where the color filters in positions (2,2) and (5,5) of each cell are of the $W1$ type, the color filters in positions (2,5) and (5,2) are of the $W3$ type. Here a $W1$ type of filter is a color filter that allows light in the known wavelength range $W1$ to propagate through the color filter, and similar for $W2$ and $W3$ type of filters. In some
30 embodiments, the remaining 32 color filters in the 6x6 cell are of the $W2$ type.

In a RGB color system, W1 may correspond to red light, W2 to green light, and W3 to blue light.

In some embodiments, the scanner is configured to derive the surface color with a
5 higher resolution than the surface geometry.

In some embodiments, the higher surface color resolution is achieved by demosaicing, where color values for pixel blocks may be demosaiced to achieve an apparently higher resolution of the color image than is present in the surface
10 geometry. The demosaicing may operate on pixel blocks or individual pixels.

In case a multi-die LED or another illumination source comprising physically or optically separated light emitters is used, it is preferable to aim at a Köhler type illumination in the scanner, i.e. the illumination source is defocused at the object
15 plane in order to achieve uniform illumination and good color mixing for the entire field of view. In case color mixing is not perfect and varies with focal plane location, color calibration of the scanner will be advantageous.

In some embodiments, the pattern generating element is configured to provide that
20 the spatial pattern comprises alternating dark and bright regions arranged in a checkerboard pattern. The probe light provided by the scanner system then comprises a pattern consisting of dark sections and sections with light having the same wavelength distribution as the multichromatic light source.

In order to obtain a digital 3D representation expressing both surface geometry and color representation of an object, i.e. a colored digital 3D representation of said part of the object surface, typically several sub-scans, i.e. partial representations of the object, have to be combined, where each sub-scans presents one view of the object. A sub-scan expressing a view from a given relative position preferably
25 records the geometry and color of the object surface as seen from that relative
30 position.

For a focus scanner, a view corresponds to one pass of the focusing element(s), i.e. for a focus scanner each sub-scan is the surface geometry and color derived from the stack of 2D images recorded during the pass of the focus plane position
5 between its extremum positions.

The surface geometry found for various views can be combined by algorithms for stitching and registration as widely known in the literature, or from known view positions and orientations, for example when the scanner is mounted on axes with
10 encoders. Color can be interpolated and averaged by methods such as texture weaving, or by simply averaging corresponding color components in multiple views of the same location on the surface. Here, it can be advantageous to account for differences in apparent color due to different angles of incidence and reflection, which is possible because the surface geometry is also known. Texture weaving is
15 described by e.g. Callieri M, Cignoni P, Scopigno R. "Reconstructing textured meshes from multiple range rgb maps". VMV 2002, Erlangen, Nov 20-22, 2002.

In some embodiments, the scanner and/or the scanner system is configured for generating a sub-scan of the object surface based on the obtained surface color
20 and surface geometry.

In some embodiments, the scanner and/or the scanner system is configured for combining sub-scans of the object surface obtained from different relative positions to generate a digital 3D representation expressing the surface geometry and color
25 of at least part of the object.

In some embodiments, the combination of sub-scans of the object to obtain the digital 3D representation expressing surface geometry and color comprises computing the color in each surface point as a weighted average of corresponding
30 points in all overlapping sub-scans at that surface point. The weight of each sub-scan in the sum may be determined by several factors, such as the presence of

saturated pixel values or the orientation of the object surface with respect to the scanner when the sub-scan is recorded.

Such a weighted average is advantageous in cases where some scanner positions
5 and orientations relative to the object will give a better estimate of the actual color than other positions and orientations. If the illumination of the object surface is uneven this can to some degree also be compensated for by weighting the best illuminated parts higher.

10 In some embodiments, the data processing system of the scanner system comprises an image processor configured for performing a post-processing of the surface geometry, the surface color readings, or the derived sub-scan or the digital 3D representation of the object. The scanner system may be configured for performing the combination of the sub-scans using e.g. computer implemented
15 algorithms executed by the image processor.

The scanner system may be configured for performing the combination of the sub-scans using e.g. computer implemented algorithms executed by the data processing system as part of the post-processing of the surface geometry, surface
20 color, sub-scan and/or the digital 3D representation, i.e. the post-processing comprises computing the color in each surface point as a weighted average of corresponding points in all overlapping sub-scans at that surface point.

Saturated pixel values should preferably have a low weight to reduce the effect of
25 highlights on the recording of the surface color. The color for a given part of the surface should preferably be determined primarily from 2D images where the color can be determined precisely which is not the case when the pixel values are saturated.

30 In some embodiments, the scanner and/or scanner system is configured for detecting saturated pixels in the captured 2D images and for mitigating or removing

the error in the obtained color caused by the pixel saturation. The error caused by the saturated pixel may be mitigated or removed by assigning a low weight to the saturated pixel in the weighted average.

5 Specularly reflected light has the color of the light source rather than the color of the object surface. If the object surface is not a pure white reflector then specular reflections can hence be identified as the areas where the pixel color closely matches the light source color. When obtaining the surface color it is therefore advantageous to assign a low weight to pixels or pixel groups whose color values
10 closely match the color of the multichromatic light source in order to compensate for such specular reflections.

Specular reflections may also be a problem when intra orally scanning a patient's set of teeth since teeth rarely are completely white. It may hence be advantageous
15 to assume that for pixels where the readings from the color images sensor indicate that the surface of the object is a pure white reflector, the light recorded by this pixel group is caused by a specular reflection from the teeth or the soft tissue in the oral cavity and accordingly assign a low weight to these pixels to compensate for the specular reflections.

20
In some embodiments, the compensation for specular reflections from the object surface is based on information derived from a calibration of the scanner in which a calibration object e.g. in the form of a pure white reflector is scanned. The color image sensor readings then depend on the spectrum of the multichromatic light
25 source and on the wavelength dependence of the scanner's optical system caused by e.g. a wavelength dependent reflectance of mirrors in the optical system. If the optical system guides light equally well for all wavelengths of the multichromatic light source, the color image sensor will record the color (also referred to as the spectrum) of the multichromatic light source when the pure white reflector is
30 scanned.

In some embodiments, compensating for the specular reflections from the surface is based on information derived from a calculation based on the wavelength dependence of the scanner's optical system, the spectrum of the multichromatic light source and a wavelength dependent sensitivity of the color image sensor. In

5 some embodiments, the scanner comprises means for optically suppressing specularly reflected light to achieve better color measurement. This may be provided if the scanner further comprises means for polarizing the probe light, for example by means of at least one polarizing beam splitter.

10 When scanning inside an oral cavity there may be red ambient light caused by probe light illumination of surrounding tissue, such as the gingiva, palette, tongue or buccal tissue. In some embodiments, the scanner and/or scanner system is hence configured for suppressing the red component in the recorded 2D images.

15 In some embodiments, the scanner and/or scanner system is configured for comparing the color of sections of the captured 2D images and/or of the sub-scans of the object with predetermined color ranges for teeth and for oral tissue, respectively, and for suppressing the red component of the recorded color for sections where the color is not in either one of the two predetermined color ranges.

20 The teeth may e.g. be assumed to be primarily white with one ratio between the intensity of the different components of the recorded image, e.g. with one ratio between the intensity of the red component and the intensity of the blue and/or green components in a RGB configuration, while oral tissue is primarily reddish with another ratio between the intensity of the components. When a color recorded for a

25 region of the oral cavity shows a ratio which differs from both the predetermined ratio for teeth and the predetermined ratio for tissue, this region is identified as a tooth region illuminated by red ambient light and the red component of the recorded image is suppressed relative to the other components, either by reducing the recorded intensity of the red signal or by increasing the recorded intensities of the

30 other components in the image.

In some embodiments, the color of points with a surface normal directly towards the scanner are weighted higher than the color of points where the surface normal is not directed towards the scanner. This has the advantage that points with a surface normal directly towards the scanner will to a higher degree be illuminated by the white light from the scanner and not by the ambient light.

In some embodiments, the color of points with a surface normal directly towards the scanner are weighted lower if associated with specular reflections.

In some embodiments the scanner is configured for simultaneously compensating for different effects, such as compensating for saturated pixels and/or for specular reflections and/or for orientation of the surface normal. This may be done by generally raising the weight for a selection of pixels or pixel groups of a 2D image and by reducing the weight for a fraction of the pixels or pixel groups of said selection.

In some embodiments, the method comprises a processing of recorded 2D images, a sub-scan or the generated 3D representations of the part of the object, where said processing comprises

- compensating for pixel saturation by omitting or reducing the weight of saturated pixels when deriving the surface color, and/or
- compensating for specular reflections when deriving the surface color by omitting or reducing the weight of pixels whose color values closely matches the light source color, and/or
- compensating for red ambient light by comparing surface color information of the 2D images with predetermined color ranges, and suppressing the red component of the recorded color if this is not within a predetermined color range.

Disclosed is a method of using the disclosed scanner system to display color texture on the generated digital 3D representation of the object. It is advantageous

to display the color data as a texture on the digital 3D representation, for example on a computer screen. The combination of color and geometry is a more powerful conveyor of information than either type of data alone. For example, dentists can more easily differentiate between different types of tissue. In the rendering of the surface geometry, appropriate shading can help convey the surface geometry on the texture, for example with artificial shadows revealing sharp edges better than texture alone could do.

When the multichromatic light source is a multi-die LED or similar, the scanner system can also be used to detect fluorescence. Disclosed is a method of using the disclosed scanner system to display fluorescence on surface geometry.

In some embodiments, the scanner is configured for exciting fluorescence on said object by illuminating it with only a subset of the LED dies in the multi-die LED, and where said fluorescence is recorded by only or preferentially reading out only those pixels in the color image sensor that have color filters at least approximately matching the color of the fluoresced light, i.e. measuring intensity only in pixels of the image sensors that have filters for longer-wavelength light. In other words, the scanner is capable of selectively activating only a subset of the LED dies in the multi-die LED and of only recording or preferentially reading out only those pixels in the color image sensor that have color filters at a higher wavelength than that of the subset of the LED dies, such that light emitted from the subset of LED dies can excite fluorescent materials in the object and the scanner can record the fluorescence emitted from these fluorescent materials. The subset of the dies preferably comprises one or more LED dies which emits light within the excitation spectrum of the fluorescent materials in the object, such as an ultraviolet, a blue, a green, a yellow or a red LED die. Such fluorescence measurement yields a 2D data array much like the 2D color image, however unlike the 2D image it cannot be taken concurrently with the surface geometry. For a slow-moving scanner, and/or with appropriate interpolation, the fluorescence image can still be overlaid the surface

geometry. It is advantageous to display fluorescence on teeth because it can help detect caries and plaque.

5 In some embodiments, the data processing system comprises a microprocessor unit configured for extracting the surface geometry information from 2D images obtained by the color image sensor and for determining the surface color from the same images.

10 The data processing system may comprise units distributed in different parts of the scanner system. For a scanner system comprising a handheld part connected to a stationary unit, the data processing system may for example comprise one unit integrated in the handheld part and another unit integrated in the stationary unit. This can be advantageous when a data connection for transferring data from the handheld unit to the stationary unit has a bandwidth which cannot handle the data stream from the color image sensor. A preliminary data processing in the handheld unit can then reduce the amount of data which must be transferred via the data connection.

20 In some embodiments, the data processing system comprises a computer readable medium on which is stored computer implemented algorithms for performing said post-processing.

In some embodiments, a part of the data processing system is integrated in a cart or a personal computer.

25

Disclosed is a method of using the disclosed scanner system to average color and/or surface geometry from several views, where each view represents a substantially fixed relative orientation of scanner and object.

30 Disclosed is a method using the disclosed scanner system to combine color and/or surface geometry from several views, where each view represents a substantially

fixed relative orientation of scanner and object, such as to achieve a more complete coverage of the object than would be possible in a single view.

Disclosed is a scanner for obtaining surface geometry and surface color of an object, the scanner comprising:

- a multichromatic light source configured for providing a probe light, and
 - a color image sensor comprising an array of image sensor pixels for recording one or more 2D images of light received from said object,
- where at least for a block of said image sensor pixels, both surface color and surface geometry of a part of the object are derived at least partly from one 2D image recorded by said color image sensor

Disclosed is a scanner system for recording surface geometry and surface color of an object, the scanner system comprising:

- a multichromatic light source configured for providing a multichromatic probe light, and
 - a color image sensor comprising an array of image sensor pixels for capturing one or more 2D images of light received from said object,
- where at least for a block of said image sensor pixels, both surface color information and surface geometry information of a part of the object are derived at least partly from one 2D image captured by said color image sensor.

Disclosed is a scanner system for recording surface geometry and surface color of an object, the scanner system comprising:

- a multichromatic light source configured for providing a probe light,
 - a color image sensor comprising an array of image sensor pixels, and
 - an optical system configured for guiding light received from the object to the color image sensor such that 2D images of said object can be captured by said color image sensor;
- wherein the scanner system is configured for capturing a number of said 2D images of a part of the object and for deriving both surface color information and surface

geometry information of the part of the object from at least one of said captured 2D images at least for a block of said color image sensor pixels, such that the surface color information and the surface geometry information are obtained concurrently by the scanner.

5

Disclosed is a scanner system for recording surface geometry and surface color of an object, the scanner system comprising:

- a multichromatic light source configured for providing a probe light;
- a color image sensor comprising an array of image sensor pixels, where
10 the image sensor is arranged to capture 2D images of light received from the object; and
- an image processor configured for deriving both surface color information and surface geometry information of at least a part of the object from at least one of said 2D images captured by the color image sensor.

15

Disclosed is a scanner system for recording surface geometry and surface color of an object, said scanner system comprising

- a scanner system according to any of the embodiments, where the scanner system is configured for deriving surface color and surface
20 geometry of the object, and optionally for generating a sub-scan or a digital 3D representation of the part of the object; and
- a data processing unit configured for post-processing surface geometry and/or surface color readings from the color image sensor, or for post-processing the generated sub-scan or digital 3D representation.

25

Disclosed is a method of recording surface geometry and surface color of an object, the method comprising:

- providing a scanner or scanner system according to any of the embodiments;
- 30 - illuminating the surface of said object with probe light from said multichromatic light source;

- recording one or more 2D images of said object using said color image sensor; and
- deriving both surface color and surface geometry of a part of the object from at least some of said recorded 2D images at least for a block of said image sensor pixels, such that the surface color and surface geometry are obtained concurrently by the scanner.

Brief description of drawings

- 10 Fig. 1 shows a handheld embodiment of a scanner system.
Figs. 2A-2B shows prior art pattern generating means and associated reference weights.
Figs. 3A-3B shows a pattern generating means and associated reference weights.
Fig. 4 shows a color filter array.
- 15 Fig. 5 shows a flow chart of a method.
Figs. 6A-6C illustrates how surface geometry information and surface geometry information can be derived

Fig. 1 shows a handheld part of a scanner system with components inside a housing 100. The scanner comprises a tip which can be entered into a cavity, a multichromatic light source in the form of a multi-die LED 101, pattern generating element 130 for incorporating a spatial pattern in the probe light, a beam splitter 140, color image sensor 180 including an image sensor 181, electronics and potentially other elements, an optical system typically comprising at least one lens, and the image sensor. The light from the light source 101 travels back and forth through the optical system 150. During this passage the optical system images the pattern 130 onto the object being scanned 200 which here is a patient's set of teeth, and further images the object being scanned onto the image sensor 181.

The image sensor 181 has a color filter array 1000. Although drawn as a separate entity, the color filter array is typically integrated with the image sensor, with a single-color filter for every pixel.

5 The lens system includes a focusing element 151 which can be adjusted to shift the focal imaging plane of the pattern on the probed object 200. In the example embodiment, a single lens element is shifted physically back and forth along the optical axis.

10 As a whole, the optical system provides an imaging of the pattern onto the object being probed and from the object being probed to the camera.

The device may include polarization optics 160. Polarization optics can be used to selectively image specular reflections and block out undesired diffuse signal from
15 sub-surface scattering inside the scanned object. The beam splitter 140 may also have polarization filtering properties. It can be advantageous for optical elements to be anti-reflection coated.

The device may include folding optics, a mirror 170, which directs the light out of the
20 device in a direction different to the optical path of the lens system, e.g. in a direction perpendicular to the optical path of the lens system.

There may be additional optical elements in the scanner, for example one or more condenser lens in front of the light source 101.

25

In the example embodiment, the LED 101 is a multi-die LED with two green, one red, and one blue die. Only the green portion of the light is used for obtaining the surface geometry. Accordingly, the mirror 170 is coated such as to optimize preservation of the circular polarization of the green light, and not that of the other
30 colors. Note that during scanning all dies within the LED are active, i.e., emitting light, so the scanner emits apparently white light onto the scanned object 200. The

LED may emit light at the different colors with different intensities such that e.g. one color is more intense than the other colors. This may be desired in order to reduce cross-talk between the readings of the different color signals in the color image sensor. In case that the intensity of e.g. the red and blue diodes in a RGB system is reduced, the apparently white light emitted by the light source will appear greenish-white.

The scanner system further comprises a data processing system configured for deriving both surface geometry information and surface color information for a block of pixels of the color image sensor 180 at least partly from one 2D image recorded by said color image sensor 180. At least part of the data processing system may be arranged in the illustrated handheld part of the scanner system. A part may also be arranged in an additional part of the scanner system, such as a cart connected to the handheld part.

Figures 2A-2B show an section of a prior art pattern generating element 130 that is applied as a static pattern in a spatial correlation embodiment of WO2010145669, as imaged on a monochromatic image sensor 180. The pattern can be a chrome-on-glass pattern. The section shows only a portion of the pattern is shown, namely one period. This period is represented by a pixel block of 6 by 6 image pixels, and 2 by 2 pattern fields. The fields drawn in gray in Fig. 2A are in actuality black because the pattern mask is opaque for these fields; gray was only chosen for visibility and thus clarity of the Figure. Fig. 2B illustrates the reference weights f for computing the spatial correlation measure A for the pixel block, where $n = 6 \times 6 = 36$, such that

$$A = \sum_{i=1}^n f_i I_i$$

where I are the intensity values measured in the 36 pixels in the pixel block for a given image. Note that perfect alignment between image sensor pixels and pattern fields is not required, but gives the best signal for the surface geometry measurement.

Figs. 3A-3B shows the extension of the principle in Figs. 2A-2B to color scanning. The pattern is the same as in Figs. 2A-2B and so is the image sensor geometry. However, the image sensor is a color image sensor with a Bayer color filter array. In Fig. 3A, pixels marked "B" have a blue color filter, while "G" indicates green and "R" red pixel filters, respectively. Fig. 3B shows the corresponding reference weights f . Note that only green pixels have a non-zero value. This is so because only the green fraction of the spectrum is used for recording the surface geometry information.

10 For the pattern/color filter combination of Figs. 3A-3B, a color component c_j within a pixel block can be obtained as

$$c_j = \sum_{i=1}^n g_{j,i} I_i$$

where $g_{j,i} = 1$ if pixel i has a filter for color c_j , 0 otherwise. For an RGB color filter array like in the Bayer pattern, j is one of red, green, or blue. Further weighting of the individual color components, i.e., color calibration, may be required to obtain natural color data, typically as compensation for varying filter efficiency, illumination source efficiency, and different fraction of color components in the filter pattern. The calibration may also depend on focus plane location and/or position within the field of view, as the mixing of the LED's component colors may vary with those factors.

20 Figure 4 shows an inventive color filter array with a higher fraction of green pixels than in the Bayer pattern. The color filter array comprises a plurality of cells of 6x6 color filters, with blue color filters in positions (2,2) and (5,5) of each cell, red color filters in positions (2,5) and (5,2), and green color filters in all remaining positions of the cell.

25 Assuming that only the green portion of the illumination is used to obtain the surface geometry information, the filter of Figure 4 will potentially provide a better quality of the obtained surface geometry than a Bayer pattern filter, at the expense of poorer color representation. The poorer color representation will however in many cases

still be sufficient while the improved quality of the obtained surface geometry often is very advantageous.

Fig. 5 illustrates a flow chart 541 of a method of recording surface geometry and surface color of an object.

In step 542 a scanner system according to any of the previous claims is obtained.

In step 543 the object is illuminated with multichromatic probe light. In a focus scanning system utilizing a correlation measure or correlation measure function, a checkerboard pattern may be imposed on the probe light such that information relating to the pattern can be used for determining surface geometry information from captured 2D images.

In step 544 a series of 2D images of said object is captured using said color image sensor. The 2D images can be processed immediately or stored for later processing in a memory unit.

In step 545 both surface geometry information and surface color information are derived for a block of image sensor pixels at least partly from one captured 2D image. The information can e.g. be derived using the correlation measure approach as described herein. The derived informations are combined to generate a sub-scan of the object in step 546, where the sub-scan comprises data expressing the geometry and color of the object as seen from one view.

In step 547 a digital 3D representation expressing both color and geometry of the object is generated by combining several sub-scans. This may be done using known algorithms for sub-scan alignment such as algorithms for stitching and registration as widely known in the literature.

Figs. 6A-6C illustrates how surface geometry information and surface geometry information can be derived at least from one 2D image for a block of image sensor pixels.

5 The correlation measure is determined for all active image sensor pixel groups on the color image sensor for every focus plane position, i.e. for every 2D image of the stack. Starting by analyzing the 2D images from one end of the stack, the correlation measures for all active image sensor pixel groups is determined and the calculated values are stored. Progressing through the stack the correlation
10 measures for each pixel group are determined and stored together with the previously stored values, i.e. the values for the previously analyzed 2D images. A correlation measure function describing the variation of the correlation measure along the optical axis is then determined for each pixel group by smoothing and interpolating the determined correlation measure values. For example, a polynomial
15 can be fitted to the values of for a pixel block over several images on both sides of the recorded maximum, and a location of a deducted maximum can be found from the maximum of the fitted polynomial, which can be in between two images. The surface color information for the pixel group is derived from one or more of the 2D images from which the position of the correlation measure maximum was
20 determined i.e. surface geometry information and surface color information from a group of pixels of the color image sensor are derived from the same 2D images of the stack.

The surface color information can be derived from one 2D image. The maximum
25 value of the correlation measure for each group of pixels is monitored along the analysis of the 2D images such that when a 2D image has been analyzed the values for the correlation measure for the different pixels groups can be compared with the currently highest value for the previously analyzed 2D images. If the correlation measure is a new maximum value for that pixel group at least the portion
30 of the 2D image corresponding to this pixel group is saved. Next time a higher correlation value is found for that pixel group the portion of this 2D image is saved

overwriting the previously stored image/sub-image. Thereby when all 2D images of the stack have been analyzed, the surface geometry information of the 2D images is translated into a series of correlation measure values for each pixel group where a maximum value is recorded for each block of image sensor pixels.

5

Fig. 6A illustrated a portion 661 of a stack of 2D images acquired using a focus scanning system, where each 2D image is acquired at a different focal plane position. In each 2D image 662 a portion 663 corresponding to a block of image sensor pixels are indicated. The block corresponding to a set of coordinates (x_i, y_i) .

10 The focus scanning system is configured for determining a correlation measure for each block of image sensor pixels and for each 2D image in the stack. In Fig. 6B is illustrated the determined correlation measures 664 (here indicated by an "x") for the block 663. Based on the determined correlation measures 664 a correlation measure function 665 is calculated, here as a polynomial, and a maximum value for
15 the correlation measure function is found a position z_i . The z-value for which the fitted polynomial has a maximum (z_i) is identified as a point of the object surface. The surface geometry information derived for this block can then be presented in the form of the coordinates (x_i, y_i, z_i) , and by combining the surface geometry information for several block of the images sensor, the a sub-scan expressing the
20 geometry of part of the object can be created.

In Fig. 6C is illustrated a procedure for deriving the surface color geometry from two 2D images for each block of image sensor pixels. Two 2D images are stored using the procedure described above and their RGB values for the pixel block are
25 determined. In Fig. 6C the R-values 666 are displayed. An averaged R-value 667 (as well as averaged G- and B-values) at the z_i position can then be determined by interpolation and used as surface color information for this block. This surface color information is evidently derived from the same 2D image that the geometry information at least in part was derived from.

30

Electronic Acknowledgement Receipt

EFS ID:	31459930
Application Number:	14764087
International Application Number:	
Confirmation Number:	6247
Title of Invention:	FOCUS SCANNING APPARATUS RECORDING COLOR
First Named Inventor/Applicant Name:	Bo ESBECH
Customer Number:	21839
Filer:	Travis Dean Boone/Denise Williams
Filer Authorized By:	Travis Dean Boone
Attorney Docket Number:	00791 24-000111
Receipt Date:	10-JAN-2018
Filing Date:	28-JUL-2015
Time Stamp:	14:05:47
Application Type:	U.S. National Stage under 35 USC 371

Payment information:

Submitted with Payment	no
------------------------	----

File Listing:

Document Number	Document Description	File Name	File Size(Bytes)/ Message Digest	Multi Part /.zip	Pages (if appl.)
1	Transmittal Letter	Corrected_Application_Papers.pdf	89989 <small>07b8229b2d7c9cf2425bdeb7c372e771492ca28</small>	no	3

Warnings:

Information:					
2		18_01_10_312_AMENDMENT.pdf	79063 1c25866f21952a647bd22fe180b6ebd34961dce0	yes	3
Multipart Description/PDF files in .zip description					
		Document Description	Start	End	
		Amendment after Notice of Allowance (Rule 312)	1	1	
		Specification	2	2	
		Applicant Arguments/Remarks Made in an Amendment	3	3	
Warnings:					
Information:					
3	Specification	18_01_10_Corrected_Spec.pdf	242263 1adc3603ffff8238b187749c171cf8653d343f0b	no	34
Warnings:					
Information:					
Total Files Size (in bytes):			411315		
<p>This Acknowledgement Receipt evidences receipt on the noted date by the USPTO of the indicated documents, characterized by the applicant, and including page counts, where applicable. It serves as evidence of receipt similar to a Post Card, as described in MPEP 503.</p> <p><u>New Applications Under 35 U.S.C. 111</u> If a new application is being filed and the application includes the necessary components for a filing date (see 37 CFR 1.53(b)-(d) and MPEP 506), a Filing Receipt (37 CFR 1.54) will be issued in due course and the date shown on this Acknowledgement Receipt will establish the filing date of the application.</p> <p><u>National Stage of an International Application under 35 U.S.C. 371</u> If a timely submission to enter the national stage of an international application is compliant with the conditions of 35 U.S.C. 371 and other applicable requirements a Form PCT/DO/EO/903 indicating acceptance of the application as a national stage submission under 35 U.S.C. 371 will be issued in addition to the Filing Receipt, in due course.</p> <p><u>New International Application Filed with the USPTO as a Receiving Office</u> If a new international application is being filed and the international application includes the necessary components for an international filing date (see PCT Article 11 and MPEP 1810), a Notification of the International Application Number and of the International Filing Date (Form PCT/RO/105) will be issued in due course, subject to prescriptions concerning national security, and the date shown on this Acknowledgement Receipt will establish the international filing date of the application.</p>					



UNITED STATES PATENT AND TRADEMARK OFFICE

UNITED STATES DEPARTMENT OF COMMERCE
United States Patent and Trademark Office
Address: COMMISSIONER FOR PATENTS
P.O. Box 1450
Alexandria, Virginia 22313-1450
www.uspto.gov

Table with 5 columns: APPLICATION NO., FILING DATE, FIRST NAMED INVENTOR, ATTORNEY DOCKET NO., CONFIRMATION NO.
Row 1: 14/764,087, 07/28/2015, Bo ESBECH, 0079124-000111, 6247
Row 2: 21839, 7590, 01/05/2018, BUCHANAN, INGERSOLL & ROONEY PC, POST OFFICE BOX 1404, ALEXANDRIA, VA 22313-1404
Row 3: EXAMINER PYO, KEVIN K
Row 4: ART UNIT 2878, PAPER NUMBER
Row 5: NOTIFICATION DATE 01/05/2018, DELIVERY MODE ELECTRONIC

Please find below and/or attached an Office communication concerning this application or proceeding.

The time period for reply, if any, is set in the attached communication.

Notice of the Office communication was sent electronically on above-indicated "Notification Date" to the following e-mail address(es):

ADIPDOC1@BIPC.com



UNITED STATES PATENT AND TRADEMARK OFFICE

Commissioner for Patents
United States Patent and Trademark Office
P. O. Box 1450
Alexandria, VA 22313-1450
www.uspto.gov

Application No. : 14764087
Applicant : Esbech
Filing Date : 07/28/2015
Date Mailed : 01/05/2018

NOTICE TO FILE CORRECTED APPLICATION PAPERS

Notice of Allowance Mailed

This application has been accorded an Allowance Date and is being prepared for issuance. The application, however, is incomplete for the reasons below.

Applicant is given two (2) months from the mail date of this Notice within which to respond. This time period for reply is extendable under 37 CFR 1.136(a) for only TWO additional MONTHS.

The informalities requiring correction are indicated in the attachment(s). If the informality pertains to the abstract, specification (including claims) or drawings, the informality must be corrected with an amendment in compliance with 37 CFR 1.121 (or, if the application is a reissue application, 37 CFR 1.173). Such an amendment may be filed after payment of the issue fee if limited to correction of informalities noted herein. See Waiver of 37 CFR 1.312 for Documents Required by the Office of Patent Publication, 1280 Off. Gaz. Patent Office 918 (March 23, 2004). In addition, if the informality is not corrected until after payment of the issue fee, for purposes of 35 U.S.C. 154(b)(1)(iv), "all outstanding requirements" will be considered to have been satisfied when the informality has been corrected. A failure to respond within the above-identified time period will result in the application being ABANDONED.

See attachment(s).

*A copy of this notice **MUST** be returned with the reply. Please address response to
"Mail Stop Issue Fee, Commissioner for Patents,
P.O. Box 1450, Alexandria, VA 22313-1450".*

/Midel Geronimo/
Publication Branch
Office of Data Management
(571) 272-4200

Application No. 14764087

SPECIFICATION NOT IN COMPLIANCE WITH 37 CFR 1.52(b)(5)

The pages of the specification document coded SPEC dated 07/28/2015 have not been numbered. Per 37 CFR 1.52(b)(5), “the pages of the specification including claims and abstract must be numbered consecutively, beginning with 1, the numbers being centrally located above or preferably below, the text.” In response to this notice, the applicant must submit a substitute specification in which the pages are so numbered.

NOTE: Although 37 CFR 1.52(b)(5) refers to page numbering for “the specification including claims and abstract,” any abstract or claims submitted in response to this notice will not be entered. Only the substitute specification, and any amendment thereto entered during prosecution, will be entered.



UNITED STATES PATENT AND TRADEMARK OFFICE

UNITED STATES DEPARTMENT OF COMMERCE
United States Patent and Trademark Office
Address: COMMISSIONER FOR PATENTS
P.O. Box 1450
Alexandria, Virginia 22313-1450
www.uspto.gov

APPLICATION NO.	FILING DATE	FIRST NAMED INVENTOR	ATTORNEY DOCKET NO.	CONFIRMATION NO.
14/764,087	07/28/2015	Bo ESBECH	0079124-000111	6247
21839	7590	01/17/2018	EXAMINER	
BUCHANAN, INGERSOLL & ROONEY PC POST OFFICE BOX 1404 ALEXANDRIA, VA 22313-1404			PYO, KEVIN K	
			ART UNIT	PAPER NUMBER
			2878	
			NOTIFICATION DATE	DELIVERY MODE
			01/17/2018	ELECTRONIC

Please find below and/or attached an Office communication concerning this application or proceeding.

The time period for reply, if any, is set in the attached communication.

Notice of the Office communication was sent electronically on above-indicated "Notification Date" to the following e-mail address(es):

ADIPDOC1@BIPC.com

Response to Rule 312 Communication	Application No.	Applicant(s)
	14/764,087	
	Examiner	Art Unit

-- The MAILING DATE of this communication appears on the cover sheet with the correspondence address --

1. The amendment filed on 10 January 2018 under 37 CFR 1.312 has been considered, and has been:
- a) entered.
 - b) entered as directed to matters of form not affecting the scope of the invention.
 - c) disapproved because the amendment was filed after the payment of the issue fee.
Any amendment filed after the date the issue fee is paid must be accompanied by a petition under 37 CFR 1.313(c)(1) and the required fee to withdraw the application from issue.
 - d) disapproved. See explanation below.
 - e) entered in part. See explanation below.

Publishing Division

B.Crittenden

--	--

INFORMATION DISCLOSURE STATEMENT BY APPLICANT (Not for submission under 37 CFR 1.99)	Application Number	14764087
	Filing Date	2015-07-28
	First Named Inventor	Bo ESBECH
	Art Unit	2878
	Examiner Name	PYO, KEVIN K
	Attorney Docket Number	0079124-000111

U.S.PATENTS							Remove	
Examiner Initial*	Cite No	Patent Number	Kind Code ¹	Issue Date	Name of Patentee or Applicant of cited Document	Pages,Columns,Lines where Relevant Passages or Relevant Figures Appear		
	1							
If you wish to add additional U.S. Patent citation information please click the Add button.							Add	
U.S.PATENT APPLICATION PUBLICATIONS							Remove	
Examiner Initial*	Cite No	Publication Number	Kind Code ¹	Publication Date	Name of Patentee or Applicant of cited Document	Pages,Columns,Lines where Relevant Passages or Relevant Figures Appear		
	1							
If you wish to add additional U.S. Published Application citation information please click the Add button.							Add	
FOREIGN PATENT DOCUMENTS							Remove	
Examiner Initial*	Cite No	Foreign Document Number ³	Country Code ²	Kind Code ⁴	Publication Date	Name of Patentee or Applicant of cited Document	Pages,Columns,Lines where Relevant Passages or Relevant Figures Appear	T ⁵
	1	2007117152	JP	A	2007-05-17	Pentax CORP		
	2	2009109263	JP	A	2009-05-21	Lasertec CORP		
If you wish to add additional Foreign Patent Document citation information please click the Add button							Add	
NON-PATENT LITERATURE DOCUMENTS							Remove	

INFORMATION DISCLOSURE STATEMENT BY APPLICANT (Not for submission under 37 CFR 1.99)	Application Number		14764087
	Filing Date		2015-07-28
	First Named Inventor	Bo ESBECH	
	Art Unit		2878
	Examiner Name	PYO, KEVIN K	
	Attorney Docket Number		0079124-000111

Examiner Initials*	Cite No	Include name of the author (in CAPITAL LETTERS), title of the article (when appropriate), title of the item (book, magazine, journal, serial, symposium, catalog, etc), date, pages(s), volume-issue number(s), publisher, city and/or country where published.	T ⁵
	1	Office Action (Notice of Reasons for Rejection) issued on January 9, 2018, by the Japanese Patent Office in Japanese Patent Application No. 2015-557430, and an English Translation of the Office Action. (8 pages)	X

If you wish to add additional non-patent literature document citation information please click the Add button

EXAMINER SIGNATURE

Examiner Signature		Date Considered	
--------------------	--	-----------------	--

*EXAMINER: Initial if reference considered, whether or not citation is in conformance with MPEP 609. Draw line through a citation if not in conformance and not considered. Include copy of this form with next communication to applicant.

¹ See Kind Codes of USPTO Patent Documents at www.USPTO.GOV or MPEP 901.04. ² Enter office that issued the document, by the two-letter code (WIPO Standard ST.3). ³ For Japanese patent documents, the indication of the year of the reign of the Emperor must precede the serial number of the patent document. ⁴ Kind of document by the appropriate symbols as indicated on the document under WIPO Standard ST.16 if possible. ⁵ Applicant is to place a check mark here if English language translation is attached.

INFORMATION DISCLOSURE STATEMENT BY APPLICANT (Not for submission under 37 CFR 1.99)	Application Number	14764087
	Filing Date	2015-07-28
	First Named Inventor	Bo ESBECH
	Art Unit	2878
	Examiner Name	PYO, KEVIN K
	Attorney Docket Number	0079124-000111

CERTIFICATION STATEMENT

Please see 37 CFR 1.97 and 1.98 to make the appropriate selection(s):

That each item of information contained in the information disclosure statement was first cited in any communication from a foreign patent office in a counterpart foreign application not more than three months prior to the filing of the information disclosure statement. See 37 CFR 1.97(e)(1).

OR

That no item of information contained in the information disclosure statement was cited in a communication from a foreign patent office in a counterpart foreign application, and, to the knowledge of the person signing the certification after making reasonable inquiry, no item of information contained in the information disclosure statement was known to any individual designated in 37 CFR 1.56(c) more than three months prior to the filing of the information disclosure statement. See 37 CFR 1.97(e)(2).

See attached certification statement.

The fee set forth in 37 CFR 1.17 (p) has been submitted herewith.

A certification statement is not submitted herewith.

SIGNATURE

A signature of the applicant or representative is required in accordance with CFR 1.33, 10.18. Please see CFR 1.4(d) for the form of the signature.

Signature	/Travis D. Boone/	Date (YYYY-MM-DD)	2018-03-26
Name/Print	Travis D. Boone	Registration Number	52,635

This collection of information is required by 37 CFR 1.97 and 1.98. The information is required to obtain or retain a benefit by the public which is to file (and by the USPTO to process) an application. Confidentiality is governed by 35 U.S.C. 122 and 37 CFR 1.14. This collection is estimated to take 1 hour to complete, including gathering, preparing and submitting the completed application form to the USPTO. Time will vary depending upon the individual case. Any comments on the amount of time you require to complete this form and/or suggestions for reducing this burden, should be sent to the Chief Information Officer, U.S. Patent and Trademark Office, U.S. Department of Commerce, P.O. Box 1450, Alexandria, VA 22313-1450. **DO NOT SEND FEES OR COMPLETED FORMS TO THIS ADDRESS. SEND TO: Commissioner for Patents, P.O. Box 1450, Alexandria, VA 22313-1450.**

Privacy Act Statement

The Privacy Act of 1974 (P.L. 93-579) requires that you be given certain information in connection with your submission of the attached form related to a patent application or patent. Accordingly, pursuant to the requirements of the Act, please be advised that: (1) the general authority for the collection of this information is 35 U.S.C. 2(b)(2); (2) furnishing of the information solicited is voluntary; and (3) the principal purpose for which the information is used by the U.S. Patent and Trademark Office is to process and/or examine your submission related to a patent application or patent. If you do not furnish the requested information, the U.S. Patent and Trademark Office may not be able to process and/or examine your submission, which may result in termination of proceedings or abandonment of the application or expiration of the patent.

The information provided by you in this form will be subject to the following routine uses:

1. The information on this form will be treated confidentially to the extent allowed under the Freedom of Information Act (5 U.S.C. 552) and the Privacy Act (5 U.S.C. 552a). Records from this system of records may be disclosed to the Department of Justice to determine whether the Freedom of Information Act requires disclosure of these records.
2. A record from this system of records may be disclosed, as a routine use, in the course of presenting evidence to a court, magistrate, or administrative tribunal, including disclosures to opposing counsel in the course of settlement negotiations.
3. A record in this system of records may be disclosed, as a routine use, to a Member of Congress submitting a request involving an individual, to whom the record pertains, when the individual has requested assistance from the Member with respect to the subject matter of the record.
4. A record in this system of records may be disclosed, as a routine use, to a contractor of the Agency having need for the information in order to perform a contract. Recipients of information shall be required to comply with the requirements of the Privacy Act of 1974, as amended, pursuant to 5 U.S.C. 552a(m).
5. A record related to an International Application filed under the Patent Cooperation Treaty in this system of records may be disclosed, as a routine use, to the International Bureau of the World Intellectual Property Organization, pursuant to the Patent Cooperation Treaty.
6. A record in this system of records may be disclosed, as a routine use, to another federal agency for purposes of National Security review (35 U.S.C. 181) and for review pursuant to the Atomic Energy Act (42 U.S.C. 218(c)).
7. A record from this system of records may be disclosed, as a routine use, to the Administrator, General Services, or his/her designee, during an inspection of records conducted by GSA as part of that agency's responsibility to recommend improvements in records management practices and programs, under authority of 44 U.S.C. 2904 and 2906. Such disclosure shall be made in accordance with the GSA regulations governing inspection of records for this purpose, and any other relevant (i.e., GSA or Commerce) directive. Such disclosure shall not be used to make determinations about individuals.
8. A record from this system of records may be disclosed, as a routine use, to the public after either publication of the application pursuant to 35 U.S.C. 122(b) or issuance of a patent pursuant to 35 U.S.C. 151. Further, a record may be disclosed, subject to the limitations of 37 CFR 1.14, as a routine use, to the public if the record was filed in an application which became abandoned or in which the proceedings were terminated and which application is referenced by either a published application, an application open to public inspections or an issued patent.
9. A record from this system of records may be disclosed, as a routine use, to a Federal, State, or local law enforcement agency, if the USPTO becomes aware of a violation or potential violation of law or regulation.

(11)Publication number	2007-117152
(43)Date of publication of application	17.05.2007
(51)Int. Cl.	A61B 1/04 (2006.01) G02B 23/24 (2006.01) H04N 7/18 (2006.01)
(21)Application number	2005-309471
(22)Date of filing	25.10.2005
(71)Applicant	PENTAX CORP
(72)Inventor	SUDA TADAAKI

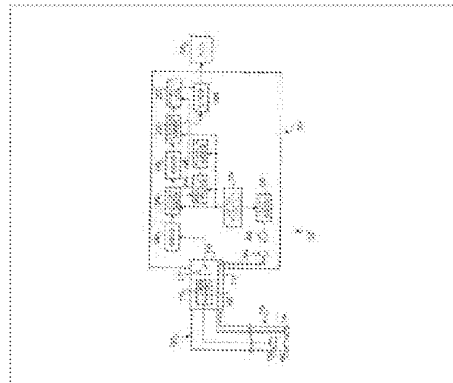
**(54)ELECTRONIC ENDOSCOPE SYSTEM****(57)Abstract**

PROBLEM TO BE SOLVED: To display a part to be saturated in a surely saturated state relating to video images imaged by a low pixel CCD.

SOLUTION: The electronic endoscope system comprises: an electronic endoscope having an imaging device capable of imaging a lumen in colors; a luminance detection means for detecting the values of the luminance signals of the respective pixels of the imaging device; a saturation determination means for determining whether or not the pixel is saturated on the basis of the detected value of the luminance signal; and a color signal attenuation means for attenuating color signals corresponding to the pixel determined as being saturated.

*** NOTICES ***

JPO and INPIT are not responsible for any damages caused by the use of this translation.

1. This document has been translated by computer. So the translation may not reflect the original precisely.
2. **** shows the word which can not be translated.
3. In the drawings, any words are not translated.

CLAIMS

[Claim(s)]

[Claim 1]

An electronic endoscope with an image sensor which can be imaged in color for a lumen,
A luminance detection means which detects a value of a luminance signal of each pixel of the
aforementioned image sensor,
A saturation deciding means to judge whether the pixel is saturated based on a value of a
detected luminance signal,

An electronic endoscope system provided with a color signal attenuating means which
attenuates a color signal with which it corresponded to a pixel judged that it is saturated.

[Claim 2]

The electronic endoscope system according to claim 1 when the aforementioned saturation
deciding means is [a value of a detected luminance signal] more than a value which shows a
white level, wherein it judges with the pixel being saturated.

[Claim 3]

A signal processing means which performs predetermined processing to an output signal of
each pixel,

Input timing of a color signal input into the aforementioned color signal attenuating means via
the aforementioned signal processing means, Claim 1 or an electronic endoscope system
described in any of Claim 2 further having an input timing synchronous means which
synchronizes input timing of a signal with which it corresponded to the color signal input into
the aforementioned color signal attenuating means via the aforementioned luminance detection
means and the aforementioned saturating deciding means.

[Claim 4]

The electronic endoscope system according to claim 3, wherein the aforementioned input
timing synchronous means is a delay circuit which carries out the specified time lag of the color
signal which goes via the aforementioned signal processing means.

*** NOTICES ***

JPO and INPIT are not responsible for any damages caused by the use of this translation.

- 1.This document has been translated by computer. So the translation may not reflect the original precisely.
- 2.**** shows the word which can not be translated.
- 3.In the drawings, any words are not translated.

DETAILED DESCRIPTION

[Detailed Description of the Invention]

[Field of the Invention]

[0001]

This invention relates to the electronic endoscope system provided with the electronic endoscope which mounted low pixel CCD on that point.

[Background of the Invention]

[0002]

The electronic endoscope system provided with the electronic endoscope which equipped the point with the image sensor, and the processor which processes the signal outputted from the image sensor, and it outputs to a monitor is known widely, and practical use is presented with it.

[0003]

An electronic endoscope is inserted into a patient's lumen and used. In order to make pressure of the lumen by an electronic endoscope reduce and to make the burden to a patient ease, making an electronic endoscope narrow-diameter-size as much as possible is demanded constantly. Adopting low pixel CCD (Charge Coupled Devices) as the image sensor which should be installed, for example at a tip as one of the methods for making an electronic endoscope narrow-diameter-size is mentioned. As compared with high pixel CCD, the size (area of a light receiving surface) of low pixel CCD (for example, referred to as CCD of 300,000 pixels or less) is small. For this reason, it can become a factor which makes an electronic endoscope narrow-diameter-size. For example, the electronic endoscope which mounted low pixel CCD is described in the following Patent document 1.

[0004]

The electronic endoscope system is equipped with the light source for illuminating the lumen which is an observing object. Here, the portion applied strongly has the dramatically bright illumination light from a light source. Therefore, there is dramatically much reflected light quantity from the portion, and the output voltage of the pixel (photo detector arranged on the light receiving surface of CCD) which carried out light reception of this may be saturated. For this reason, the portion in which the illumination light from a light source is put strongly is on a monitor, and may be displayed white.

[Patent document 1] JP 2002 - 112953A

[Description of the Invention]

[Problem to be solved by the invention]

[0005]

As compared with high pixel CCD, an obtained image is rude and low pixel CCD has a conspicuous noise. For this reason, in the drive control system of low pixel CCD, making the preset value of a gain low and making a noise not conspicuous is generally performed.

[0006]

Low pixel CCD has a small output (signal amplitude). However, since a gain cannot be highly set up for the Reason mentioned above, the saturation level of a pixel must be set up by few margins to maximum signal amplitude. Even if it is original, when it is desirable to use the half of maximum signal amplitude as a saturation level, it is obliged to set 70% as a saturation level actually. However, as a trade-off to having decreased the margin to maximum signal amplitude and having secured the output level, when the image of a lumen was imaged using the electronic endoscope which mounted such low pixel CCD, The above-mentioned portion (portion in which the illumination light is put strongly) which cannot absorb sensitivity dispersion of a pixel but should be displayed white essentially may be displayed on a monitor by redness, blueness or yellowish tinge credit, and *****. That is, the portion which should be saturated is not saturated but an unnecessary irregular color may be displayed.

[0007]

Then, the present invention makes it problem to provide the electronic endoscope system which can be displayed where the portion which should be saturated is reliably saturated in light of the above-mentioned circumstances about the image imaged by low pixel CCD.

[Means for solving problem]

[0008]

The present invention which solves the above-mentioned problem is characterized by an electronic endoscope system concerning one mode comprising the following.

An electronic endoscope with an image sensor which can be imaged in color for a lumen.

A luminance detection means which detects a value of a luminance signal of each pixel of an image sensor.

A saturation deciding means to judge whether the pixel is saturated based on a value of a detected luminance signal.

A color signal attenuating means which attenuates a color signal with which it corresponded to a pixel judged that it is saturated.

[0009]

The saturation deciding means can judge with the pixel being saturated, when the value of the detected luminance signal is more than the value which shows a white level.

[0010]

The signal processing means by which the above-mentioned electronic endoscope system performs predetermined processing to the output signal of each pixel, The input timing of the color signal input into a color signal attenuating means via a signal processing means, It may further have an input timing synchronous means which synchronizes the input timing of the signal with which it corresponded to the color signal input into a color signal attenuating means via a luminance detection means and a saturation deciding means.

[0011]

An input timing synchronous means may be a delay circuit which carries out the specified time lag of the color signal which goes via a signal processing means.

[Effect of the Invention]

[0012]

If the electronic endoscope system of the present invention is adopted, the portion which should be saturated can be displayed in the state where you made it saturated reliably, about the image imaged by low pixel CCD.

[Best Mode of Carrying Out the Invention]

[0013]

Hereinafter, with reference to Drawings, it describes about composition and a working effect of the electronic endoscope system of this embodiment.

[0014]

Fig.1 is the figure showing roughly the appearance of the electronic endoscope system 10 of an embodiment of the invention. Fig.2 is a block diagram showing the composition of the electronic endoscope system 10 of an embodiment of the invention. The electronic endoscope system 10 of this embodiment is a system for observing and diagnosing a patient's lumen, and has the electronic endoscope 100, the processor 200, and the monitor 300.

[0015]

The connector unit 110 is provided by the end piece of the electronic endoscope 100 of this embodiment. The connector unit 110 has two pin plugs. The processor side connector area 210 is provided by the front surface of the processor 200. The processor side connector area 210 has two jacks. It is for the pin plug jack of each set performing optical connection and an electrical link, respectively. Therefore, by connecting the connector unit 110 and the processor side connector area 210, the electronic endoscope 100 and the processor 200 are optically and electrically connected.

[0016]

The end of the universal cord 120 has combined with the connector unit 110. The universal cord 120 has flexibility and the end has already combined it with the operating part 130.

[0017]

The operating part 130 is an input interface for making an operator operate the electronic endoscope 100. For example, an observation area can be made to be able to change, or a washing liquid can be made to inject in a lumen by operating the operating part 130. The end of the inserting part flexible tube 140 has combined with the operating part 130.

[0018]

The inserting part flexible tube 140 is a pipe inserted in a patient's lumen, and has flexibility. The point 150 is provided at the tip. If the inserting part flexible tube 140 near point 150 root is bent by operation of the operating part 130, the angle of the point 150 will change and an observation area will also be changed in connection with it.

[0019]

The point 150 is formed for the hard material (for example, resin), and each element needed for imaging processing is provided. The above-mentioned elements in this embodiment are the light-distribution lens 152, the object lens 154, and CCD156. The light-distribution lens 152 and the object lens 154 are lenses with which the point 150 was installed in front. CCD156 is color CCD of the low pixel (a pixel number is 300,000 or less) of for example, the Bayer system. The many pixel (photo detector) is arranged by matrix form in the light receiving surface. The ontip color filter is mounted on the light-receiving presence surface. Which color chip of R (Red), G (Green), and B (Blue) corresponds to each pixel, and a color filter is arranged by matrix form. CCD156 used here is not limited to what mounted the primary colors filter, for example, may mount a complementary color filter.

[0020]

Along with the longitudinal direction, the light guide 160 is installed in electronic endoscope 100 inside. The light guide 160 is an optical fiber, the end is arranged near the pin plug for performing optical connection (connector unit 110 inside), and the end is already arranged at about 152 light-distribution lens. The CCD drive control circuit 170 for carrying out drive controlling of CCD156 and the amplifier 172 which amplifies a CCD signal (after-mentioned) with a predetermined amplification factor are mounted in connector unit 110 inside.

[0021]

The processor 200 has the system control unit 220 which controls the whole equipment in generalization. Processing by each component is performed under control of the system control unit 220. It has the lamp 230, the lamp control circuit 232, and the condenser 234 as light equipment.

[0022]

The lamp 230 is a light source of the white light for irradiating the inside of a lumen. A metal halide lamp, a xenon lamp and a halogen lamp, etc. are assumed by the lamp 230. The lamp 230 emits white light by control of the lamp control circuit 232. The synchrotron radiation from the lamp 230 is condensed by the condenser 234 installed ahead of the lamp 230. The condensed light enters into electronic endoscope 100 inside (correctly core of the light guide 160) via the processor side connector area 210.

[0023]

The light which entered into the light guide 160 is transmitted, and emits the inside from the end on the point 150 side. After outgoing radiation, it emanates outside via the light-distribution lens 152, and a lumen is illuminated. Thereby, the inside of the lumen which light does not reach is illuminated brightly.

[0024]

It is reflected in a lumen and the illumination light emitted from the light-distribution lens 152 enters into the object lens 154. Here, CCD156 is arranged so that the light receiving surface may turn into an image formation face of the object lens 154 with homotopic substantially. Therefore, the light which entered into the object lens 154 is imaged by the power of the object lens 154 as an optical image of a lumen on the light receiving surface of CCD156. CCD156 drives by control of the CCD drive control circuit 170, accumulates the optical image imaged in each pixel as an electric charge according to the light volume, and converts it to a CCD signal. The converted CCD signal is outputted by control of the CCD drive control circuit 170 from CCD156 to predetermined timing. After an output, it is amplified with a predetermined amplification factor with the amplifier 172, and is outputted to the processor 200. The CCD signal of each pixel is outputted to the processor 200 in the given order.

[0025]

It describes about the amplification factor of the amplifier 172. The amplification factor of the amplifier 172 is set up to make the level with which an image with high reproducibility is acquired amplify a CCD signal. Here, the saturation region used as the linear zone which will be in a linear state, and saturation exists in the relation of the incident light quantity and the output voltage value in a pixel. In order to display an image with high reproducibility, it is desirable for incident light quantity and an output voltage value to use the CCD signal in a linear zone (when it puts in another way, it is desirable not to use the CCD signal in a saturation region). The pressure value to which it corresponded to the boundary of the above-mentioned linear zone and the above-mentioned saturation region is described as a "output saturation voltage value."

[0026]

The output saturation voltage value in each pixel originates in dispersion in the sensitivity characteristic for every pixel, and differ, respectively. A sensitivity characteristic here, it is expressed with the ratio of an output voltage value to incident light quantity. If the amplification factor of the amplifier 172 is set up in accordance with a pixel with the lowest output saturation voltage value, in all the pixels, the output voltage value of a CCD signal will be settled in a linear zone. The amplification factor of the amplifier 172 is set as the value which the upper limit (white level) of a prescribed range is made to make the lowest output saturation voltage value. When an output voltage value is upper limit of a prescribed range, the portion is displayed white on the monitor 300. When an output voltage value is a lower limit (black level) of a prescribed range, the portion is displayed black on the monitor 300.

[0027]

Next, it describes about signal processing performed by the processor 200, as the means in connection with processing of a CCD signal in the processor 200 -- the insulation circuit 240, the CCD signal processing circuit 242, the saturation level detection circuit 244, the attenuator control circuit 246, the delay circuit 248, the video signal processing circuit 250, and the attenuator circuit 252 -- and, it has the output circuit 254.

[0028]

The CCD signal of each pixel outputted from the electronic endoscope 100 is input into the CCD signal processing circuit 242 via the processor side connector area 210 and the insulation circuit 240. The insulation circuit 240 is insulating the electronic endoscope 100 and the processor 200 electrically by converting temporarily the signal which transmits between the electronic endoscope 100 and the processors 200 to another medium (here light), for example by a photocoupler etc.

[0029]

The CCD signal processing circuit 242 performs well-known signal processing, operates the CCD signal of each pixel input sequentially one by one, and generates the signal (it is hereafter described as a "color component signal") about a color component (any of R component, G component, and B component are they?), and a luminance signal. The set of the color component signal generated in the CCD signal processing circuit 242 and the luminance signal with which it corresponded to it is described as a "picture signal." The CCD signal processing circuit 242 outputs the picture signal concerned to the delay circuit 248, whenever it generates the picture signal with which it corresponded to stroke matter, and computes the information (it is hereafter described as "luminance value information") which shows the pressure value of the luminance signal with which it corresponded to it, and outputs it to the saturation level detection circuit 244.

[0030]

The saturation level detection circuit 244 compares with a predetermined threshold value each luminance value information input sequentially, and outputs the comparison result to the attenuator control circuit 246. A predetermined threshold value is a value to which it corresponded, the upper limit, i.e., the white level, of the above-mentioned prescribed range.

[0031]

Output saturation voltage values differ for every (every [namely,] R, G, and B component) color component, respectively. In connection with this, the upper limit of the above-mentioned prescribed range of each color component also differs, respectively. Therefore, the saturation level detection circuit 244 needs to set up a threshold value to which it corresponded to each color component and which is different for every luminance value information, respectively in the above-mentioned comparison processing. Here, it corresponds to the arrangement of a pixel in the saturation level detection circuit 244, and luminance value information inputs in the given order. for this reason, for the saturation level detection circuit 244, it resembles each

luminance value information input sequentially, respectively, and a relation with the color component to which it corresponded is known (specifically, it resembles each luminance value information input sequentially, respectively, and has the data table which associated the color component to which it corresponded). By referring to the above-mentioned data table, the saturation level detection circuit 244 can set up a respectively suitable threshold value to each luminance value information input sequentially, and can perform comparison processing. For example, when the luminance value information to which it corresponded to G component and R component is input alternately, first, to the luminance value information by which (1) input was carried out, the saturation level detection circuit 244 sets up the threshold value to which it corresponded to G component, and performs comparison processing. Subsequently, the threshold value to which it corresponded to R component is set up to the luminance value information by which (2) inputs were carried out, and comparison processing is performed. Comparison processing to which it corresponded, for example to the pixel of one line is realized by carrying out repeat execution of the processing of (1) and (2).

[0032]

The attenuator control circuit 246 performs saturation deciding processing of a pixel (correctly luminance signal) based on the comparison result from the saturation level detection circuit 244. Specifically, when luminance value information expresses beyond a predetermined threshold value in a comparison result, it judges with the luminance signal with which it corresponded to it being saturated. On the other hand, when it expresses that luminance value information is lower than a predetermined threshold value in a comparison result, it judges with the luminance signal with which it corresponded to it not being saturated. When the former decided result is given, a predetermined control signal is outputted to the attenuator circuit 252. When the latter decided result is given, neither of the signals is outputted.

[0033]

Each picture signal outputted is stored for a predetermined period in the delay circuit 248 from the CCD signal processing circuit 242. It is outputted to the video signal processing circuit 250 after storing for a predetermined period. The video signal processing circuit 250 processes the picture signal input, and converts it to the form (a color signal and a luminance signal) which can be expressed as the monitor 300. After conversion, while the direct entry of the luminance signal is carried out to the output circuit 254, a color signal is input into the output circuit 254 via the attenuator circuit 252. In the attenuator circuit 252 by carrying out the specified time lag of each picture signal in the delay circuit 248. The input timing of the color signal from the video signal processing circuit 250 and the input timing of the predetermined control signal from the attenuator control circuit 246 where it corresponded to the color signal concerned synchronize.

[0034]

The color signal with which it corresponded to each pixel is input into the attenuator circuit 252 in the given order. When there is no signal input from the attenuator control circuit 246 at the time of a color signal input, the attenuator circuit 252 outputs the color signal to the output circuit 254, without performing processing [which]. On the other hand, when the above-mentioned predetermined control signal inputs at the time of a color signal input, the component of the color signal concerned is attenuated and it outputs to the output circuit 254. That is, the component of the color signal with which it corresponded to the luminance signal judged that the attenuator circuit 252 was saturated is attenuated, and the tint of the video section to which it corresponds to it is lost (that is, white is used).

[0035]

The output circuit 254 converts a color signal and a luminance signal to the video signals (for example, a composite video signal, S video signal or a RGB video signal, etc.) of each form, and outputs them to the monitor 300. Thereby, the image of a lumen is displayed on the monitor 300. In this embodiment, the component of the color signal with which it corresponded to the saturated luminance signal is attenuated by the attenuator circuit 252, and the tint of the image of the pixel to which it corresponded to it is reduced. For this reason, the image of the portion which should be saturated is not that to which the unnecessary tint was attached, and is displayed in the original state (namely, white or the tint very near white). For this reason, on the monitor 300, the operator can observe the image of a lumen in the state where it reappeared more correctly.

[0036]

The above is an embodiment of the present invention. The present invention is not limited to these embodiments and can deform in various ranges.

[0037]

Although processing which attenuates a color signal to each of pixels is performed in this embodiment, it may be made to be performed by the above-mentioned processing bundling up to a plurality of pixels in another embodiment.

[0038]

According to the another above-mentioned embodiment, for example decision processing with the predetermined threshold value over each pixel is serial, is performed, and the memory which the result does not illustrate memorizes. With reference to the memory, in a continuous case, the pixel judged by the above-mentioned decided result to be beyond a threshold value bundles up the processing which attenuates a color signal to those pixels, and more than a predetermined number performs the system control unit 220. In another viewpoint, when the pixel judged to be beyond a threshold value does not continue in more than a predetermined number, processing which attenuates a color signal to those pixels is not performed. That is, in another embodiment, unless the saturation portion on the monitor 300 has a certain amount of size, a color signal is not attenuated. Thereby, the processing burden of the control system for attenuating a color signal is eased.

[Brief Description of the Drawings]

[0039]

A [FIG. 1] It is the figure showing roughly the appearance of the electronic endoscope system of an embodiment of the invention.

A [FIG. 2] It is a block diagram showing the composition of the electronic endoscope system of an embodiment of the invention.

[Explanations of letters or numerals]

[0040]

10 Electronic endoscope system

100 Electronic endoscope

154 CCD

200 Processor

220 System control unit

244 Saturation level detection circuit

246 Attenuator control circuit

248 Delay circuit

250 Video signal processing circuit

252 Attenuator circuit

300 Monitor

*** NOTICES ***

JPO and INPIT are not responsible for any damages caused by the use of this translation.

1. This document has been translated by computer. So the translation may not reflect the original precisely.

2. **** shows the word which can not be translated.

3. In the drawings, any words are not translated.

DRAWINGS

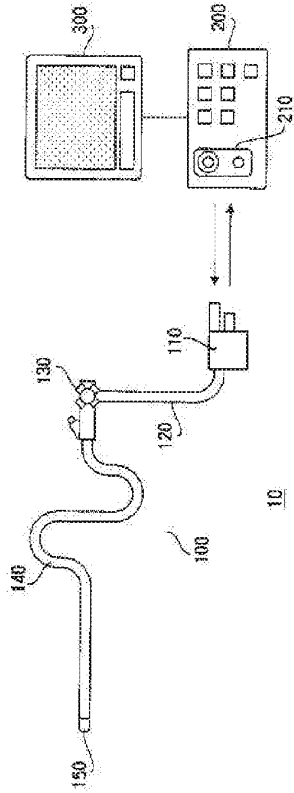

A [FIG. 1]

A [FIG. 2]

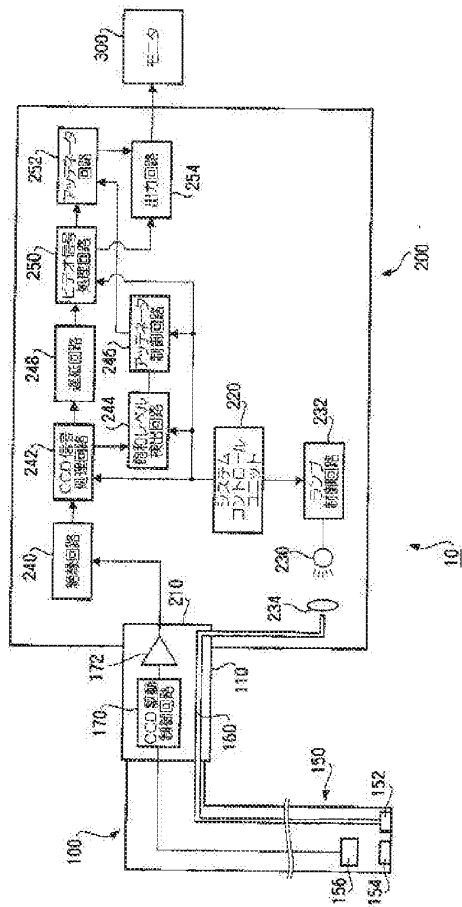

(19) 日本国特許庁 (JP)

(12) 公開特許公報 (A)

(11) 特許出願公開番号

特開2007-117152
(P2007-117152A)

(43) 公開日 平成19年5月17日 (2007. 5. 17)

(51) Int. Cl.	F I	テーマコード (参考)
A61B 1/04 (2006.01)	A61B 1/04 372	2H040
G02B 23/24 (2006.01)	G02B 23/24 B	4C061
H04N 7/18 (2006.01)	H04N 7/18 M	5C054

審査請求 未請求 請求項の数 4 O L (全 8 頁)

(21) 出願番号 特願2005-309471 (P2005-309471)
(22) 出願日 平成17年10月25日 (2005. 10. 25)

(71) 出願人 000000527
ペンタックス株式会社
東京都板橋区前野町2丁目3番9号
(74) 代理人 100078880
弁理士 松岡 修平
(72) 発明者 須田 忠明
東京都板橋区前野町2丁目3番9号 ペンタックス株式会社内
Fターム (参考) 2H040 CA09 CA11 CA23 DA11 DA15
DA21 DA53 FA13 GA02 GA05
GA08 GA11
4C061 CC06 LL02 MM02 NN01 PP12
RR02 RR22 SS10 SS18 SS21
5C054 CD03 ED03 EE04 HA12

(54) 【発明の名称】 電子内視鏡システム

(57) 【要約】

【課題】 低画素 CCD で撮像される映像に関して、飽和されるべき部分を確実に飽和させた状態で表示させる。

【解決手段】 管腔をカラーで撮像可能な撮像素子を有した電子内視鏡と、撮像素子の各画素の輝度信号の値を検出する輝度検出手段と、検出された輝度信号の値に基づいてその画素が飽和しているか否かを判定する飽和判定手段と、飽和していると判定された画素に対応したカラー信号を減衰させるカラー信号減衰手段とを備えた電子内視鏡システムを提供する。

【選択図】 図2

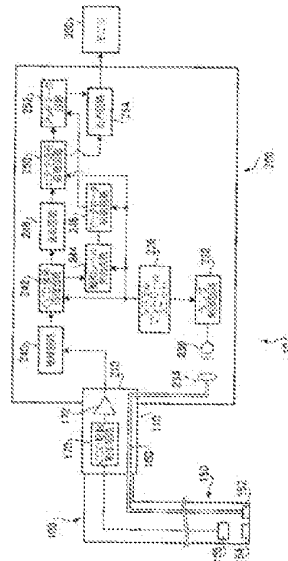

【特許請求の範囲】

【請求項 1】

管腔をカラーで撮像可能な撮像素子を有した電子内視鏡と、
前記撮像素子の各画素の輝度信号の値を検出する輝度検出手段と、
検出された輝度信号の値に基づいてその画素が飽和しているか否かを判定する飽和判定手段と、

飽和していると判定された画素に対応したカラー信号を減衰させるカラー信号減衰手段と、を備えたこと、を特徴とする電子内視鏡システム。

【請求項 2】

前記飽和判定手段は、検出された輝度信号の値が白レベルを示す値以上であるとき、その画素が飽和していると判定すること、を特徴とする請求項 1 に記載の電子内視鏡システム。

10

【請求項 3】

各画素の出力信号に所定の処理を施す信号処理手段と、
前記信号処理手段を経由して前記カラー信号減衰手段に入力するカラー信号の入力タイミングと、前記輝度検出手段と前記飽和判定手段を経由して前記カラー信号減衰手段に入力する該カラー信号に対応した信号の入力タイミングとを同期させる入力タイミング同期手段と、を更に備えたこと、を特徴とする請求項 1 又は請求項 2 の何れかに記載の電子内視鏡システム。

【請求項 4】

前記入力タイミング同期手段は、前記信号処理手段を経由するカラー信号を所定時間遅延させる遅延回路であること、を特徴とする請求項 3 に記載の電子内視鏡システム。

20

【発明の詳細な説明】

【技術分野】

【0001】

この発明は、その先端部に低画素 CCD を搭載した電子内視鏡を備えた電子内視鏡システムに関する。

【背景技術】

【0002】

その先端部に撮像素子を備えた電子内視鏡と、該撮像素子から出力される信号を処理してモニタに出力するプロセッサとを備えた電子内視鏡システムが広く知られ実用に供されている。

30

【0003】

電子内視鏡は例えば患者の管腔内に挿入されて用いられる。電子内視鏡による管腔の圧迫を軽減させて患者に対する負担を軽減させるため、電子内視鏡をできる限り細径化させることが恒常的に要求されている。電子内視鏡を細径化させるための方法の一つとして、例えば先端に設置されるべき撮像素子に低画素 CCD (Charge Coupled Devices) を採用することが挙げられる。低画素 CCD (例えば 30 万画素以下の CCD とする) は高画素 CCD と比較してそのサイズ (受光面の面積) が小さい。このため、電子内視鏡を細径化させる要因となり得る。例えば下記特許文献 1 には低画素 CCD を搭載した電子内視鏡が記載されている。

40

【0004】

電子内視鏡システムには、観察対象である管腔を照明するための光源が備えられている。ここで、光源からの照明光が強く当てられている部分は非常に明るい。従ってその部分からの反射光量は非常に多く、これを受光した画素 (CCD の受光面上に配列された受光素子) の出力電圧は飽和し得る。このため、光源からの照明光が強く当てられている部分はモニタ上で白く表示され得る。

【特許文献 1】特開 2002-112958 号公報

【発明の開示】

【発明が解決しようとする課題】

50

【0005】

低画素CCDは高画素CCDと比較して取得画像が荒く且つノイズが目立ち易い。このため、低画素CCDの駆動制御系ではゲインの設定値を低くしてノイズを目立たなくさせることが一般的に行われている。

【0006】

また、低画素CCDは出力（信号振幅）が小さい。しかし上述した理由によりゲインを高く設定できないため、最大信号振幅に対して少ないマージンで画素の飽和レベルを設定しなければならない。本来であれば最大信号振幅の例えば半分を飽和レベルとすることが望ましい場合であっても、実際には70%を飽和レベルに設定する等を余儀なくされる。ところがこのような低画素CCDを搭載した電子内視鏡を用いて管腔の映像を撮像した場合、最大信号振幅に対するマージンを減少させて出力レベルを確保したことに対するトレードオフとして、画素の感度ばらつきを吸収できず本来白く表示されるべき上記部分（照明光が強く当てられている部分）が例えば赤みや青み又は黄み掛かった色合いでモニタ上に表示されてしまうことがある。すなわち飽和すべき部分が飽和せず、不要な色むらが表示され得る。

10

【0007】

そこで、本発明は上記の事情に鑑みて、低画素CCDで撮像される映像に関して、飽和されるべき部分を確実に飽和させた状態を表示させることができる電子内視鏡システムを提供することを課題としている。

【課題を解決するための手段】

20

【0008】

上記の課題を解決する本発明の一態様に係る電子内視鏡システムは、管腔をカラーで撮像可能な撮像素子を有した電子内視鏡と、撮像素子の各画素の輝度信号の値を検出する輝度検出手段と、検出された輝度信号の値に基づいてその画素が飽和しているか否かを判定する飽和判定手段と、飽和していると判定された画素に対応したカラー信号を減衰させるカラー信号減衰手段とを備えたことを特徴とする。

【0009】

なお、飽和判定手段は、検出された輝度信号の値が白レベルを示す値以上であるとき、その画素が飽和していると判定し得る。

【0010】

30

また、上記電子内視鏡システムは、各画素の出力信号に所定の処理を施す信号処理手段と、信号処理手段を経由してカラー信号減衰手段に入力するカラー信号の入力タイミングと、輝度検出手段と飽和判定手段を経由してカラー信号減衰手段に入力する該カラー信号に対応した信号の入力タイミングとを同期させる入力タイミング同期手段とを更に備えたものであっても良い。

【0011】

入力タイミング同期手段は、信号処理手段を経由するカラー信号を所定時間遅延させる遅延回路であっても良い。

【発明の効果】

【0012】

40

本発明の電子内視鏡システムを採用すると、低画素CCDで撮像される映像に関して、飽和されるべき部分を確実に飽和させた状態を表示させることができる。

【発明を実施するための最良の形態】

【0013】

以下、図面を参照して、本実施形態の電子内視鏡システムの構成及び作用について説明する。

【0014】

図1は、本発明の実施の形態の電子内視鏡システム10の外観を概略的に示した図である。また、図2は、本発明の実施の形態の電子内視鏡システム10の構成を示したブロック図である。本実施形態の電子内視鏡システム10は、患者の管腔を観察・診断するため

50

のシステムであり、電子内視鏡 100、プロセッサ 200、及び、モニタ 300 を有している。

【0015】

本実施形態の電子内視鏡 100 の末端部にはコネクタユニット 110 が設けられている。コネクタユニット 110 は二本のピンプラグを有している。また、プロセッサ 200 のフロント面にはプロセッサ側コネクタ部 210 が設けられている。プロセッサ側コネクタ部 210 は二つのジャックを有している。各対のピンプラグージャックはそれぞれ光学的接続と電気的接続を果たすためのものである。従ってコネクタユニット 110 とプロセッサ側コネクタ部 210 とが接続されることにより、電子内視鏡 100 とプロセッサ 200 とが光学的且つ電気的に接続される。

10

【0016】

コネクタユニット 110 にはユニバーサルコード 120 の一端が結合している。ユニバーサルコード 120 は可撓性を有しており、もう一端が操作部 130 に結合している。

【0017】

操作部 130 は電子内視鏡 100 を術者に操作させるための入力インターフェースである。操作部 130 を操作することにより、例えば観察領域を変更させたり管腔内に洗浄液を噴射させたりすることができる。操作部 130 には挿入部可撓管 140 の一端が結合している。

【0018】

挿入部可撓管 140 は患者の管腔に挿入される管であり、可撓性を有している。その先端には先端部 150 が設けられている。操作部 130 の操作によって先端部 150 根元付近の挿入部可撓管 140 が屈曲されると先端部 150 のアングルが変化し、それに伴って観察領域も変更される。

20

【0019】

先端部 150 は硬質性の素材（例えば樹脂）で形成されており、撮像処理に必要とされる各要素が設けられている。本実施形態における上記要素は、配光レンズ 152、対物レンズ 154、及び、CCD 156 である。配光レンズ 152、及び、対物レンズ 154 は先端部 150 の前面に設置されたレンズである。CCD 156 は例えばベイヤー方式の低画素（例えば画素数が 30 万以下）のカラー CCD である。受光面には多数の画素（受光素子）がマトリクス状に配列されている。受光面前面にはオンチップカラーフィルタが搭載されている。カラーフィルタは、R (Red)、G (Green)、B (Blue) の何れかのカラーチップが各画素に対応してマトリクス状に配列されたものである。なお、ここで用いられる CCD 156 は原色フィルタを搭載したものに限定されず、例えば補色フィルタを搭載したものであっても良い。

30

【0020】

なお、電子内視鏡 100 内部にはその長手方向に沿ってライトガイド 160 が設置されている。ライトガイド 160 は光ファイバであり、その一端は光学的接続を果たすためのピンプラグ近傍（コネクタユニット 110 内部）に配置され、もう一端は配光レンズ 152 近傍に配置されている。また、コネクタユニット 110 内部には、CCD 156 を駆動制御するための CCD 駆動制御回路 170、及び、CCD 信号（後述）を所定の増幅率で増幅するアンプ 172 が実装されている。

40

【0021】

プロセッサ 200 は、装置全体の制御を統括的に行うシステムコントロールユニット 220 を有している。システムコントロールユニット 220 の制御下で、各構成要素での処理が実行される。また、光源装置として、ランプ 230、ランプ制御回路 232、及び、集光レンズ 234 を有している。

【0022】

ランプ 230 は管腔内を照射するための白色光の光源である。ランプ 230 には例えばメタルハライドランプや、キセノンランプ、ハロゲンランプ等が想定される。ランプ 230 はランプ制御回路 232 の制御により白色光を放射する。ランプ 230 からの放射光は

50

、ランプ 230 の前方に設置された集光レンズ 234 によって集光される。集光された光は、プロセッサ側コネクタ部 210 を介して電子内視鏡 100 内部（より正確にはライトガイド 160 のコア）に入射する。

【0023】

ライトガイド 160 に入射した光はその内部を伝送されて、先端部 150 側の端部から出射する。出射後、配光レンズ 152 を介して外部に放射されて管腔を照明する。これにより、光の届かない管腔内が明るく照らされる。

【0024】

配光レンズ 152 から放射された照明光は、管腔において反射されて対物レンズ 154 に入射する。ここで、CCD 156 は、その受光面が対物レンズ 154 の結像面と実質的に同位置となるように配置されている。従って対物レンズ 154 に入射した光は、対物レンズ 154 のパワーにより CCD 156 の受光面上で管腔の光学像として結像される。CCD 156 は CCD 駆動制御回路 170 の制御により駆動して、各画素において結像された光学像をその光量に応じた電荷として蓄積して CCD 信号に変換する。変換された CCD 信号は、CCD 駆動制御回路 170 の制御により、CCD 156 から所定のタイミングで出力される。出力後、アンプ 172 により所定の増幅率で増幅されてプロセッサ 200 に出力される。なお、プロセッサ 200 には各画素の CCD 信号が所定の順序で出力される。

【0025】

アンプ 172 の増幅率について説明する。アンプ 172 の増幅率は、再現性の高い映像が得られるレベルに CCD 信号を増幅させるよう設定される。ここで、画素における入射光量と出力電圧値との関係には、リニアな状態となる線形領域と飽和状態となる飽和領域とが存在する。高い再現性で映像を表示させるためには、入射光量と出力電圧値とが線形領域内の CCD 信号を用いることが望ましい（換言すると、飽和領域内の CCD 信号を用いないことが望ましい）。なお、上記線形領域と上記飽和領域との境界に対応した電圧値を、「出力飽和電圧値」と記す。

【0026】

各画素における出力飽和電圧値は、画素毎の感度特性のばらつきに起因してそれぞれ異なる。ここでいう感度特性とは、入射光量に対する出力電圧値の比で表される。出力飽和電圧値が最も低い画素に合わせてアンプ 172 の増幅率を設定すると、全ての画素において、CCD 信号の出力電圧値が線形領域内に収まる。アンプ 172 の増幅率は、最も低い出力飽和電圧値を所定範囲の上限值（白レベル）にさせる値に設定される。なお、出力電圧値が所定範囲の上限值であるとき、その部分はモニタ 300 上で白く表示される。また、出力電圧値が所定範囲の下限值（黒レベル）であるとき、その部分はモニタ 300 上で黒く表示される。

【0027】

次に、プロセッサ 200 で実行される信号処理について説明する。プロセッサ 200 は、CCD 信号の処理に関わる手段として、絶縁回路 240、CCD 信号処理回路 242、飽和レベル検出回路 244、アッテネータ制御回路 246、遅延回路 248、ビデオ信号処理回路 250、アッテネータ回路 252、及び、出力回路 254 を有している。

【0028】

電子内視鏡 100 から出力された各画素の CCD 信号は、プロセッサ側コネクタ部 210 及び絶縁回路 240 を介して CCD 信号処理回路 242 に入力する。なお、絶縁回路 240 は、電子内視鏡 100 とプロセッサ 200 との間を伝送する信号を、例えばフォトカップラ等で別の媒体（ここでは光）に一時的に変換することにより、電子内視鏡 100 とプロセッサ 200 とを電氣的に絶縁させている。

【0029】

CCD 信号処理回路 242 は周知の信号処理を実行し、入力される各画素の CCD 信号を一つ一つ順次演算して、色成分（R 成分、G 成分、B 成分の何れか）に関する信号（以下、「色成分信号」と記す）、及び、輝度信号を生成する。なお、CCD 信号処理回路 2

42で生成された色成分信号、及び、それに対応した輝度信号のセットを「画像信号」と記す。CCD信号処理回路242は、一画素に対応した画像信号を生成する毎に、当該画像信号を遅延回路248に出力すると共に、それに対応した輝度信号の電圧値を示す情報（以下、「輝度値情報」と記す）を算出して飽和レベル検出回路244に出力する。

【0030】

飽和レベル検出回路244は、順次入力される各輝度値情報と所定の閾値とを比較して、その比較結果をアッテネータ制御回路246に出力する。なお、所定の閾値とは上記所定範囲の上限値すなわち白レベルに対応した値である。

【0031】

出力飽和電圧値は色成分毎（すなわちR、G、B成分毎）にそれぞれ異なる。これに伴って各色成分の上記所定範囲の上限値もそれぞれ異なる。従って飽和レベル検出回路244は、上記比較処理において、各色成分に対応した輝度値情報毎にそれぞれ異なる閾値を設定する必要がある。ここで、飽和レベル検出回路244には画素の配列に対応して、所定の順序で輝度値情報が入力する。このため飽和レベル検出回路244にとっては、順次入力される各輝度値情報とそれぞれに対応した色成分との関係が既知である（具体的には、順次入力される各輝度値情報とそれぞれに対応した色成分とを関連付けたデータテーブルを有している）。飽和レベル検出回路244は上記データテーブルを参照することにより、順次入力される各輝度値情報に対してそれぞれ適切な閾値を設定して比較処理を実行することができる。例えばG成分、R成分に対応した輝度値情報が交互に入力されるとき、飽和レベル検出回路244は、先ず、（1）入力された輝度値情報に対して、G成分に対応した閾値を設定して比較処理を実行する。次いで、（2）入力された輝度値情報に対して、R成分に対応した閾値を設定して比較処理を実行する。（1）、（2）の処理を繰り返し実行することにより、例えば1ラインの画素に対応した比較処理が実現される。

【0032】

アッテネータ制御回路246は、飽和レベル検出回路244からの比較結果に基づいて画素（より正確には輝度信号）の飽和判定処理を実行する。具体的には、比較結果において輝度値情報が所定の閾値以上を表す場合、それに対応した輝度信号が飽和していると判定する。これに対して、比較結果において輝度値情報が所定の閾値よりも低いことを表す場合、それに対応した輝度信号が飽和していないと判定する。前者の判定結果を下した場合、アッテネータ回路252に所定の制御信号を出力する。後者の判定結果を下した場合、何れの信号も出力しない。

【0033】

なお、CCD信号処理回路242から出力される各画像信号は、遅延回路248において所定時間格納される。所定時間格納後、ビデオ信号処理回路250に出力される。ビデオ信号処理回路250は、入力される画像信号を処理してモニタ300で表示可能な形態（カラー信号と輝度信号）に変換する。変換後、輝度信号は出力回路254に直接入力される一方で、カラー信号はアッテネータ回路252を介して出力回路254に入力される。各画像信号が遅延回路248で所定時間遅延されることにより、アッテネータ回路252において、ビデオ信号処理回路250からのカラー信号の入力タイミングと、当該カラー信号に対応した、アッテネータ制御回路246からの所定の制御信号の入力タイミングとが同期する。

【0034】

アッテネータ回路252には、各画素に対応したカラー信号が所定の順序で入力される。カラー信号入力時にアッテネータ制御回路246からの信号入力がない場合、アッテネータ回路252は、そのカラー信号を、何れの処理を施すこともなく出力回路254に出力する。これに対してカラー信号入力時に上記所定の制御信号が入力した場合、当該カラー信号の成分を減衰させて出力回路254に出力する。すなわちアッテネータ回路252は、飽和したと判定された輝度信号に対応したカラー信号の成分を減衰させて、それに対応する映像部分の色味をなくす（すなわち白にする）。

【0035】

出力回路 254 は、カラー信号及び輝度信号を各形式のビデオ信号（例えばコンポジットビデオ信号や S ビデオ信号或いは RGB ビデオ信号等）に変換してモニタ 300 に出力する。これにより、モニタ 300 に管腔の映像が表示される。本実施形態では、飽和した輝度信号に対応したカラー信号の成分をアッテネータ回路 252 によって減衰させて、それに対応した画素の映像の色味を低減させている。このため、飽和すべき部分の映像が、不要な色味の付いたものではなく本来の状態（すなわち白又は極めて白に近い色味）で表示される。このため術者は、モニタ 300 上において、管腔の映像をより正確に再現された状態で観察することができる。

【0036】

以上が本発明の実施形態である。本発明はこれらの実施形態に限定されるものではなく 10
様々な範囲で変形が可能である。

【0037】

なお、本実施形態では画素の一つ一つに対してカラー信号を減衰させる処理が実行されるが、別の実施形態では複数の画素に対して上記処理が一括して実行されるようにしても良い。

【0038】

上記の別の実施形態では、例えば各画素に対する所定の閾値との判定処理がシリアルで実行されて、その結果が図示しないメモリに記憶される。システムコントロールユニット 220 はそのメモリを参照して、上記判定結果で閾値以上と判定された画素が所定数以上連続した場合、それらの画素に対してカラー信号を減衰させる処理を一括して実行する。 20
別の観点では、閾値以上と判定された画素が所定数以上連続しない場合、それらの画素に対してカラー信号を減衰させる処理を実行しない。すなわち別の実施形態では、モニタ 300 上における飽和部分がある程度の大きさを有していない限り、カラー信号を減衰させない。これにより、カラー信号を減衰させるための制御系の処理負担が軽減される。

【図面の簡単な説明】

【0039】

【図 1】本発明の実施の形態の電子内視鏡システムの外観を概略的に示した図である。

【図 2】本発明の実施の形態の電子内視鏡システムの構成を示したブロック図である。

【符号の説明】

【0040】

- 10 電子内視鏡システム
100 電子内視鏡
154 CCD
200 プロセッサ
220 システムコントロールユニット
244 飽和レベル検出回路
246 アッテネータ制御回路
248 遅延回路
250 ビデオ信号処理回路
252 アッテネータ回路
300 モニタ

30

40

(11)Publication number 2009-109263
 (43)Date of publication of application 21.05.2009
 (51)Int. Cl. G01N 21/956 (2006.01)
 G01B 11/02 (2006.01)
 H01L 21/66 (2006.01)
 (21)Application number 2007-280051
 (22)Date of filing 29.10.2007
 (71)Applicant LASERTEC CORP
 (72)Inventor KUSUSE HARUHIKO

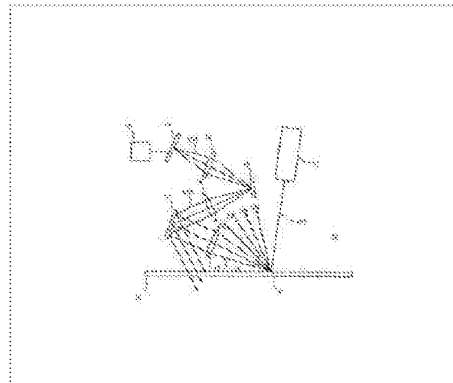
**(54)APPARATUS AND METHOD FOR INSPECTION****(57)Abstract**

PROBLEM TO BE SOLVED: To provide an inspection apparatus capable of inspecting pattern irregularities, defects, or the like, using a single apparatus.

SOLUTION: The inspection apparatus 10 is an inspection apparatus for inspecting a pattern formed on a sample 30 and includes a light source 11 for irradiating illumination light to the sample 30; a Digital Micromirror Device (DMD) 13, arranged in an optical Fourier transfer plane to the pattern of the sample 30 for reflecting diffracted light or scattered light from the sample 30; and a photodetector 17, arranged at a position conjugate to DMD 13 for receiving the light reflected at DMD 13.

*** NOTICES ***

JPO and INPIT are not responsible for any damages caused by the use of this translation.

1. This document has been translated by computer. So the translation may not reflect the original precisely.
2. **** shows the word which can not be translated.
3. In the drawings, any words are not translated.

CLAIMS

[Claim(s)]

[Claim 1]

It is the inspection apparatus which inspects a pattern formed on a sample,
A light source which irradiates illumination light to the aforementioned sample,
A digital micro mirror device (DMD) which is arranged at an optical Fourier transformation plane to a pattern of the aforementioned sample, and reflects the diffracted light or the scattered light from the aforementioned sample,
A photodetector which carries out light reception of the light which has been arranged in the above DMD and a conjugate position and was reflected with the above DMD,
Preparation *****.

[Claim 2]

The aforementioned photodetector carries out light reception of the diffracted light of a plurality of degrees,

The inspection apparatus according to claim 1, wherein pixels which carry out light reception differ according to a degree of a plurality of diffracted lights concerned.

[Claim 3]

When unevenness of a pattern of the aforementioned sample is inspected,
The inspection apparatus according to claim 2 with which the diffracted light of a degree with large strength among the diffracted lights of said plurality of degrees is characterized by a pixel of the incident above DMD being an OFF state.

[Claim 4]

When unevenness of a pattern of the aforementioned sample is inspected,
The inspection apparatus according to claim 2 or 3 with which the diffracted light of degrees other than the diffracted light of a degree with a large strength change which originated in unevenness among the diffracted lights of said plurality of degrees is characterized by a pixel of the incident above DMD being an OFF state.

[Claim 5]

Inspection apparatus of a description to any one of the Claims 2-4, wherein a different weighting factor according to a degree is set to the diffracted light of said plurality of degrees by which light reception is carried out with the aforementioned photodetector to emphasize the characteristics of unevenness of a pattern of the aforementioned sample.

[Claim 6]

The inspection apparatus according to claim 5 provided with a plurality of filter matrices by which a different weighting factor was set to each of the diffracted light of said plurality of degrees by which light reception is carried out with the aforementioned photodetector.

[Claim 7]

The inspection apparatus according to claim 1 to 6 which can change an angle to the aforementioned sample of a light-receiving system containing the above DMD and the aforementioned photodetector so that a degree of the incident diffracted light can be changed into the aforementioned photodetector.

[Claim 8]

When a defect of a pattern of a front sample is inspected,
Inspection apparatus of a description to any one of the Claims 1-7, wherein a pixel to which the diffracted light from a pattern of the aforementioned sample of the above DMD is irradiated is an OFF state.

[Claim 9]

It is an inspection method which inspects a pattern formed on a sample,
Illumination light is irradiated to the aforementioned sample,
The diffracted light or the scattered light from the aforementioned sample is reflected with a digital micro mirror device (DMD) arranged at an optical Fourier transformation plane to a pattern of the aforementioned sample,
An inspection method which carries out light reception of the light reflected with the above DMD to the above DMD with a photodetector arranged in a conjugate position.

[Claim 10]

The aforementioned photodetector carries out light reception of the diffracted light of a plurality of degrees,

The inspection method according to claim 9 which carries out light reception by a different pixel according to a degree of a plurality of diffracted lights concerned.

[Claim 11]

The inspection method according to claim 10 in inspecting unevenness of a pattern of the aforementioned sample, wherein the diffracted light of a degree with large strength among the diffracted lights of said plurality of degrees makes a pixel of the incident above DMD an OFF state.

[Claim 12]

The inspection method according to claim 10 or 11 with which the diffracted light of degrees other than the diffracted light of a degree in which strength change which originated in

unevenness among the diffracted lights of said plurality of degrees is large when inspecting unevenness of a pattern of the aforementioned sample makes a pixel of the incident above DMD an OFF state.

[Claim 13]

An inspection method of a description to any one of the Claims 10-12 which sets a different weighting factor according to a degree to the diffracted light of said plurality of degrees by which light reception is carried out with the aforementioned photodetector to emphasize the characteristics of unevenness of a pattern of the aforementioned sample.

[Claim 14]

The inspection method according to claim 13 which emphasizes strength change of the aforementioned diffracted light using a different weighting factor to each of the diffracted light of said plurality of degrees by which light reception is carried out with the aforementioned photodetector.

[Claim 15]

The inspection method according to claim 9 to 15 which changes a position to the aforementioned sample of a light-receiving system containing the above DMD and the aforementioned photodetector, and changes a degree of the incident diffracted light into the aforementioned photodetector.

[Claim 16]

An inspection method of a description to any one of the Claims 9-15 making into an OFF state a pixel to which the diffracted light from a pattern of the aforementioned sample of the above DMD is irradiated in inspecting a defect of a pattern of a front sample.

*** NOTICES ***

JPO and INPIT are not responsible for any damages caused by the use of this translation.

1. This document has been translated by computer. So the translation may not reflect the original precisely.
2. **** shows the word which can not be translated.
3. In the drawings, any words are not translated.

DETAILED DESCRIPTION

[Detailed Description of the Invention]

[Field of the Invention]

[0001]

The present invention relates to the inspection apparatus and the inspection method for inspecting patterns used by a semiconductor manufacturing process, such as a wafer and a mask.

[Background of the Invention]

[0002]

In a photo mask, a semiconductor wafer, etc. which are used by a semiconductor manufacturing process, the predetermined pattern is repeatedly formed on the substrate. The inspection apparatus which inspects the unevenness of a pattern, a foreign matter and a defect, etc. is proposed using the diffracted light (for example, primary diffracted light) which occurs conventionally from the repeated pattern formed in the surfaces, such as these masks (hereinafter referred to as "a sample") (for example, a Patent document 1 and two references). In the rejected region and normal part of a sample surface, since diffraction efficiency differs, a difference of a luminosity appears in the image based on the diffracted light from a repeated pattern, and it can pinpoint a rejected region by the light and darkness.

[0003]

A Patent document 3 has disclosed the inspection apparatus which has arranged the mirror array device at the conjugate point with the pupil position of an object lens in order to change lighting in accordance with the pattern formed in the sample. In the inspection apparatus of the description to a Patent document 3, the imaging device is arranged in the sample and the conjugate position, and the defect of the pattern is inspected by imaging the image of the sample projected with the object lens with an imaging device.

[Patent document 1] JP H10 - 232122A

[Patent document 2] JP 2001 - 141657A

[Patent document 3] JP 2006 - 23221A

[Description of the Invention]

[Problem to be solved by the invention]

[0004]

Conventionally, in the case of a defect or dust particle inspection, the lights scattered on specific angle ranges other than the angle of the diffracted light from a pattern were detected. When the unevenness of pattern line width was inspected on the other hand, the unevenness of pattern line width was detected by monitoring strength change of the diffracted light of a specific degree among the diffracted lights from a pattern. For this reason, one set of inspection apparatus was not able to realize the inspection of the defect of a pattern, and the unevenness of line width.

[0005]

The present invention is made against the background of such a situation, and the object of this invention is providing the inspection apparatus and the inspection method which can realize the inspection of the unevenness of a pattern, and the inspection of a defect or a foreign matter with one set of inspection apparatus.

[Means for solving problem]

[0006]

Inspection apparatus concerning a first mode of the present invention is characterized by comprising:

A light source which is the inspection apparatus which inspects a pattern formed on a sample, and irradiates illumination light to the aforementioned sample.

A digital micro mirror device (DMD) which is arranged at an optical Fourier transformation plane to a pattern of the aforementioned sample, and reflects the diffracted light or the scattered light from the aforementioned sample.

A photodetector which carries out light reception of the light which has been arranged in the above DMD and a conjugate position and was reflected with the above DMD.

Thereby, the unevenness inspection of a pattern and the inspection of a defect etc. are realizable with one piece of equipment.

[0007]

The pixels the aforementioned photodetector carries out light reception of the diffracted light of a plurality of degrees in the above-mentioned inspection apparatus, and the inspection apparatus concerning the second mode of the present invention carries out [pixels] light reception according to the degree of a plurality of diffracted lights concerned differ. Thereby, the diffracted light of a degree with a large change of the diffracted-light strength resulting from unevenness etc. can be determined.

[0008]

When the inspection apparatus concerning the 3rd mode of the present invention inspects the unevenness of the pattern of the aforementioned sample in the above-mentioned inspection apparatus, the diffracted light of the degree with large strength among the diffracted lights of

said plurality of degrees of the pixel of the incident above DMD is an OFF state. Thereby, inspection sensitivity can be improved.

[0009]

In the above-mentioned inspection apparatus, when inspecting the unevenness of the pattern of the aforementioned sample, the inspection apparatus concerning the 4th mode of the present invention, The diffracted light of degrees other than the diffracted light of a degree with a large strength change which originated in unevenness among the diffracted lights of said plurality of degrees of the pixel of the incident above DMD is an OFF state. Thereby, inspection sensitivity can be improved.

[0010]

The weighting factor from which the inspection apparatus concerning the fifth mode of the present invention differs according to a degree so that the characteristics of the unevenness of the pattern of the aforementioned sample may be emphasized to the diffracted light of said plurality of degrees by which light reception is carried out with the aforementioned photodetector in the above-mentioned inspection apparatus is set up. Thereby, inspection sensitivity can be improved.

[0011]

The inspection apparatus concerning the sixth mode of the present invention is provided with a plurality of filter matrices by which a different weighting factor was set to each of the diffracted light of said plurality of degrees by which light reception is carried out with the aforementioned photodetector in the above-mentioned inspection apparatus. Thereby, a filter matrix can be changed if needed.

[0012]

In the above-mentioned inspection apparatus, as the inspection apparatus concerning the seventh mode of the present invention can change the degree of the incident diffracted light into the aforementioned photodetector, it can change the angle to the aforementioned sample of a light-receiving system containing the above DMD and the aforementioned photodetector. Thereby, inspection sensitivity can be improved.

[0013]

When the inspection apparatus concerning the eighth mode of the present invention inspects the defect of the pattern of a front sample in the above-mentioned inspection apparatus, the pixel to which the diffracted light from the pattern of the aforementioned sample of the above DMD is irradiated is an OFF state. Thereby, the defect of a sample, etc. can be inspected precisely.

[0014]

The inspection method concerning the ninth mode of ***** is an inspection method which inspects the pattern formed on the sample, irradiate the illumination light to the aforementioned sample and it reflects the diffracted light or the scattered light from the aforementioned sample with the digital micro mirror device (DMD) arranged at the optical Fourier transformation plane to the pattern of the aforementioned sample, Light reception of the light reflected with the above DMD is carried out to the above DMD with the photodetector arranged in a conjugate position. Thereby, the inspection of the unevenness of a pattern and the inspection of a defect etc. are realizable.

[0015]

in the above-mentioned inspection method, the aforementioned photodetector carries out light reception of the diffracted light of a plurality of degrees, and the inspection method concerning the tenth mode of the present invention carries out light reception by a different pixel according to the degree of a plurality of diffracted lights concerned -- it carries out. Thereby, inspection sensitivity can be raised.

[0016]

When the inspection method concerning the 11th mode of the present invention inspects the unevenness of the pattern of the aforementioned sample in the above-mentioned inspection method, the diffracted light of the degree with large strength among the diffracted lights of said plurality of degrees makes the pixel of the incident above DMD an OFF state. Thereby, inspection sensitivity can be improved.

[0017]

When the inspection method concerning the 12th mode of the present invention inspects the unevenness of the pattern of the aforementioned sample in the above-mentioned inspection method, the diffracted light of degrees other than the diffracted light of a degree with a large strength change which originated in unevenness among the diffracted lights of said plurality of degrees makes the pixel of the incident above DMD an OFF state. Thereby, inspection sensitivity can be improved.

[0018]

The inspection method concerning the 13th mode of the present invention sets a different weighting factor according to a degree to the diffracted light of said plurality of degrees by which light reception is carried out with the aforementioned photodetector in the above-mentioned inspection method to emphasize the characteristics of the unevenness of the pattern of the aforementioned sample. Thereby, inspection sensitivity can be improved.

[0019]

The inspection method concerning the 14th mode of the present invention emphasizes strength change of the aforementioned diffracted light in the above-mentioned inspection method using a different weighting factor to each of the diffracted light of said plurality of degrees by which light reception is carried out with the aforementioned photodetector. Thereby, inspection sensitivity can be improved.

[0020]

In the above-mentioned inspection method, the inspection method concerning the 15th mode of the present invention changes the position to the aforementioned sample of a light-receiving system containing the above DMD and the aforementioned photodetector, and changes the

degree of the incident diffracted light into the aforementioned photodetector. Thereby, inspection sensitivity can be improved.

[0021]

In the above-mentioned inspection method, the inspection method concerning the 16th mode of the present invention makes an OFF state the pixel to which the diffracted light from the pattern of the aforementioned sample of the above DMD is irradiated, when inspecting the defect of the pattern of a front sample. Thereby, the defect of a sample, etc. can be inspected precisely.

[Effect of the Invention]

[0022]

According to the present invention, the inspection apparatus and the inspection method which can realize the inspection of the unevenness of a pattern and the inspection of a defect or a foreign matter with one set of inspection apparatus can be provided.

[Best Mode of Carrying Out the Invention]

[0023]

Hereinafter, with reference to Drawings, it describes about an embodiment of the invention. The following descriptions show the suitable embodiment of the present invention, and the range of the present invention is not limited to the form of the following Examples. In the following descriptions, that to which the same code was given shows the same contents substantially.

[0024]

About the inspection apparatus concerning an embodiment of the invention, it describes with reference to Fig.1. Fig.1 is the figure showing the basic constitution of the inspection apparatus 10. The inspection apparatus 10 concerning this embodiment inspects the unevenness of the inspection of the defect of a sample or foreign matter in which the repeated pattern was formed on the substrate, and the line width of a pattern. By the micro inspection of defect inspection etc., even if the unevenness of a pattern is judged to be a good article, slight dimension gap of a pattern occurs and it is judged as a defective article by the macro inspection by viewing.

[0025]

In the following descriptions, the inspection apparatus which inspects the sample 30 by which the repeated pattern was formed on the wafer is described as an example. A parallel, unidirectionally long line and space (a concave part and a protruding part) use a repeated pattern as the last shipment (line and space) pattern arranged with the regular interval. However, the present invention is not limited to this and can be applied also to pattern inspection, such as a photo mask and a liquid crystal display panel.

[0026]

As shown in Fig.1, the inspection apparatus 10 is provided with the light source 11, the lenses 12, 14, and 16, the digital micro mirror device (DMD) 13, the mirror 15, the photodetector 17, and the processing unit 20. In inspecting unevenness, the inspection apparatus 10 concerning this embodiment, the unevenness of a pattern is inspected by irradiating coherent light to the repeated pattern formed on the sample 30, and analyzing the diffracted light patterns (Fourier pattern) in the Fourier transformation plane obtained with a lens. When inspecting a defect, a foreign matter, etc. on the other hand, it is carried out by detecting the scattered light from a defect etc., as the diffracted light by the pattern of the sample 30 is not detected.

[0027]

Although not illustrated here, the sample 30 is adsorbed and fixed on the X-Y stage. By making an X-Y stage drive by a motor etc., the sample 30 top can be scanned by the optical beam emitted from the light source 11.

[0028]

The light source 11 emits the illumination light L01 which is coherent light to the sample 30. The laser etc. which emit a coherent light can be used as the light source 11. For example, epi-illumination of the laser beam with a wavelength of 405 nm is carried out substantially vertically to the sample 30. According to this embodiment, as a beam diameter of the illumination light L01, it may be 0.2-0.3 mm, for example. About ten patterns of the sample 30 will enter in the optical beam of the illumination light L01. In the present invention, since substantially parallel light is irradiated to the sample 30, unevenness etc. can be precisely inspected not related to a focusing position.

[0029]

In the angle of diffraction in case the incidence angle of d and the illumination light and the degree of θ and the diffracted light are m about the pitch of the repeated pattern on the sample 30, if wavelength of θ and incident light is set to λ , it is generally known that the following formulas will be realized.

$$d(\sin\theta_m - \sin\theta_i) = m\lambda \quad (m = 0, \pm 1, \dots)$$

Here, the zero-order diffracted light (direct light) has little minute defect information relatively.

For this reason, it is necessary to detect the diffracted light of a degree with a bigger absolute value than the zero-order diffracted light. Therefore, it is made for the 4th diffracted light [6th] - to enter into the lens 12 here, as shown in Fig.1. The diffracted light patterns (Fourier pattern) depending on a repeating cycle are formed in a Fourier transformation plane by interfering in the diffracted light L02 from the repeated pattern of the sample 30 each other, suiting, and passing the lens 12.

[0030]

As shown in the above-mentioned formula, the order of diffraction m and angle-of-diffraction degree θ are changed with the pitch d of a repeated pattern. In the example of Fig.1, on the lens 12, the 4th diffracted light [6th] - may be able to inspect with sensitivity more sufficient [high degree], when [incident] it can inspect with sensitivity more sufficient [lower degree (primary order / 3rd / -)], although it is made like. For this reason, as shown in Fig.2, light-receiving systems, such as DMD13 and the photodetector 17, are provided pivotable

around the center of the inspecting region O of the sample 30. Namely, the light-receiving system containing DMD13, the photodetector 17, etc. is provided so that change of the angle to the sample 30 is possible. The degree of the diffracted light which carries out light reception can be chosen by this, and it is possible to inspect the sample 30 with more sufficient sensitivity. The illumination light L01 emitted from the light source 11 is bent by a mirror etc., and it may be made to irradiate to the sample 30 in Fig.2, so that a light-receiving system and the light source 11 may not interfere.

[0031]

DMD13 is arranged at the optical Fourier transformation plane to the pattern of the sample 30. That is, DMD13 is arranged in the pupil position of a light-receiving system. Therefore, the diffracted light patterns by the repeated pattern of the sample 30 are formed on DMD13. DMD13 has the composition which arranged many minute mirror planes (micro mirror) at the plane. As DMD13, the thing by Texas Instruments, Inc. can be used, for example. Each micro mirror corresponds to a pixel, respectively. DMD13 is used as a reflection mirror which can control ON/OFF of each micro mirror at high speed for every pixel. The state where the state where the reflected light controlled each micro mirror of DMD13 on the lens 14 at incident direction controlled to the direction by which it does not enter into an ON state and the lens 14 is an OFF state. Therefore, when a micro mirror is ON, the diffracted light from the sample 30 is reflected in the incident direction by the lens 14. When a micro mirror is OFF on the other hand, the diffracted light from the sample 30 is reflected in the direction which does not enter into the lens 14.

[0032]

The diffracted light L03 reflected in the lens 14 side enters into the lens 14, and is condensed by DMD13 at the mirror 15. The light L04 reflected by the mirror 15 passes the lens 16, and enters into the photodetector 17. The photodetector 17 carries out light reception of the light reflected by DMD13, and converts it to an electric signal. The photodetector 17 is arranged in DMD13 and a conjugate position. That is, DMD13 and the photodetector 17 are arranged by each in the pupil position of a light-receiving system. It is suitable to use a one-dimensional NMO5 line sensor as the photodetector 17, for example.

[0033]

As mentioned above, in this embodiment, the pattern formed in the sample 30 is a line and space pattern. For this reason, the diffracted light of a plurality of degrees depended on the pattern of the sample 30 proceeds in the respectively specific direction. The pixel of the photodetector 17 is arranged in the direction out of which the diffracted light of a plurality of degrees from the pattern of the sample 30 has come. The pixel of DMD13 and the pixel of the photodetector 17 are arranged so that it may correspond, respectively. That is, it is reflected by the specific pixel of DMD13 and the diffracted light of a certain degree is detected by the specific pixel of the photodetector 17. An unevenness inspection is conducted by measuring strength change of the diffracted light of a plurality of degrees detected by the photodetector 17. For example, the unevenness of pattern line width is inspected based on the difference of the diffracted-light strength from the pattern of the reference used as a standard, and the diffracted-light strength from the pattern of the measured sample 30. Thus, since there are few light-receiving pixels and they end by arranging a line sensor in the direction out of which the diffracted light has come, inspection speed can be carried out early. It is also possible to use the area sensor using the two-dimensional CCD element as the photodetector 17 etc.

[0034]

In, conducting a defect or dust particle inspection on the other hand, it makes into an OFF state the pixel of DMD13 of the position where the diffracted light from the pattern of the sample 30 is projected. Thereby, the diffracted light by the pattern of the sample 30 does not enter into the photodetector 17. For this reason, when there are defects or foreign matters other than a pattern, etc., the scattered light by the defect concerned etc. is reflected in the direction of the lens 14 by the pixel of DMD13 used as an ON state. Therefore, the scattered light by a defect etc. is detected with the photodetector 17, and the inspection of a defect etc. is conducted.

[0035]

The signal with which it corresponds to the light by which light reception was carried out to the processing unit 20 with the photodetector 17 is supplied. The composition of the processing unit 20 is typically shown in Fig.3. As shown in Fig.3, the processing unit 20 is provided with the scan control part 21, the DMD control part 22, the defect decision part 23, the filter matrix selecting part 24, the calculating part 25, and the unevenness judgment part 26. The scan control part 21 controls the relative position of the stage on which the sample 30 is placed, and the light irradiated from the light source 11. The DMD control part 22 changes ON/OFF of each pixel of DMD13. The defect decision part 23 judges the existence of a defect based on the lightwave signal by which light reception was carried out with the photodetector 17, when inspecting a defect or a foreign matter.

[0036]

A plurality of filter matrices for the weighting to the diffracted light of each degree are set to the filter matrix selecting part 24. In the filter matrix selecting part 24, the optimal filter matrix is chosen based on the lightwave signal from the photodetector 17. For example, when detecting unevenness, in order to perform a weighting to the diffracted light of the large degree of strength change to line width, a filter matrix with a large coefficient is chosen. When one of the incident diffracted lights is too strong to the photodetector 17 and it is saturated, the coefficient to which it corresponds to the signal from the pixel of the photodetector 17 with which it corresponds to the diffracted light concerned can choose the thing of 0. Thereby, a light-receiving range can be expanded and unevenness can be detected more to high sensitivity. The calculating part 25 performs data processing using the filter matrix selected in the filter matrix selecting part 24. The unevenness judgment part 26 judges the unevenness of the sample 30 based on the signal by which the weighting was carried out in the calculating part 25.

[0037]

Here, it describes about the inspection method of the sample 30 using the above-mentioned inspection apparatus 10. As mentioned above, the inspection apparatus 10 concerning this embodiment realizes the inspection of the unevenness of the pattern formed in the sample 30, and the inspection of a defect or a foreign matter with one piece of equipment. First, it describes about the method of inspecting the unevenness of the pattern of the sample 30. The unevenness detection system concerning the present invention is the feature extraction of the Fourier pattern.

[0038]

First, a filter matrix is set up first. The filter matrix can carry out multidata input. About the setting method of a filter matrix, when there is no sample wafer which shook (2) CD when there was a sample wafer which shook (1) CD (critical dimension), it divides and describes.

(1) When there is a sample wafer which shook CD

The sample wafer which dose (light exposure) was changed slightly and exposed between introduction and a shot is prepared. Supposing the resist of the positive type is formed on the wafer, the pattern line width after developing negatives will change by changing a dose.

[0039]

And the whole surface of a sample wafer is scanned and the data of diffracted-light strength is incorporated. All the pixels of DMD13 are made into an ON state at this time. And the die with which pattern line width differs is specified, and a pattern is compared. When the difference of such diffracted-light strength is taken, a difference enlarges by the diffracted light of a specific degree. Therefore, an unevenness inspection can be conducted with sufficient sensitivity by monitoring strength change of the diffracted light of this degree. A filter matrix for the diffracted light of this degree to perform a weighting to the data from the pixel of the incident photodetector 17 is set up. That is, the filter matrix which emphasizes the characteristics of an error of pattern line width is determined automatically.

[0040]

It may become weak when the diffracted-light strength of a certain degree will become strong largely, if pattern line width changes. Therefore, in this way, to the large diffracted light of change, a positive or negative coefficient is applied so that the change may be emphasized. For example, even if the 4th diffracted-light strength changes pattern line width, in not changing, it sets the coefficient to the 4th diffracted light concerned to 0. If the 5th diffracted-light strength changes pattern line width, in changing largely, it applies the big coefficient which corresponds to it to the 5th diffracted light concerned. Thereby, a light-receiving range can be expanded and inspection sensitivity can be improved.

[0041]

(2) When there is no sample wafer which shook CD

The intensity map of the diffracted light from each degree of the diffracted light is created. That is, the intensity distribution of the diffracted light from the sample 30 by which light reception is carried out by each pixel of the photodetector 17 is searched for. A manual detects an abnormality area and a normal region, using the sum between the intensity maps of each diffracted light, a difference, etc. auxiliary. That is, diffracted-light strength makes a normal region the region which is not changing as compared with other observation areas of the sample 30, and it judges the region which is changing to be an abnormality area. And a filter matrix which emphasizes the characteristics of an abnormality area is set up automatically as mentioned above.

[0042]

After determining a filter matrix as mentioned above, the unevenness inspection of the actual sample 30 is conducted. Specifically, the whole surface of the sample 30 and a reference wafer is scanned first, and each diffracted light patterns are incorporated. And the difference of the diffracted-light strength of the sample 30 and the diffracted-light strength of a reference wafer is searched for. Then, data processing is performed using the filter matrix selected by the filter matrix selecting part 24 of the processing unit 20, and the characteristics which should be detected are emphasized. And in the unevenness judgment part 26, the difference of the diffracted-light strength from a reference judges a large portion, a singular point, etc. to be abnormal spots. Thus, in order for the present invention to compare the diffracted-light strength of a reference wafer and the sample 30, there is little influence of an alignment error as compared with conventional Die to Die and the detection method of Die to Database.

[0043]

In the case of a actual semiconductor wafer, there is a repeated pattern region which are a peripheral circuit part and a region to be examined. Therefore, after scanning the whole surface of a semiconductor wafer, before performing filtering, a peripheral circuit part and a region to be examined are separable using a projection or a histogram. When incorporating the diffracted light patterns of a reference wafer, the pixel of the photodetector 17 with which the diffracted-light strength of a specific degree is too strong, and it corresponds may be saturated. In this case, the pixel of DMD13 to which it corresponds can be made into an OFF state, and the coefficient of a filter matrix can be set to 0. In this case, the unevenness inspection of the sample 30 is started, making the pixel of DMD13 concerned into an OFF state, also when inspecting the sample 30. When measuring the diffracted light patterns of a reference, the sensitivity of the photodetector 17 is changed into the state where it is not changed and saturated, and it may be made to measure the diffracted light patterns of the sample 30 in this state.

[0044]

The diffracted light of a plurality of degrees is entered in the photodetector 17, the strength change resulting from unevenness determines the diffracted light of a large degree, and the diffracted light of degrees other than the diffracted light of the degree concerned is good also considering the pixel of incident DMD13 as an OFF state.

[0045]

Thus, according to the present invention, change of the diffracted-light strength resulting from unevenness inspects unevenness largely using the diffracted light of a degree with high sensitivity. For this reason, a very sensitive unevenness inspection can be conducted. By a filter matrix, since the coefficient of a big value can be applied to the diffracted-light strength of a specific degree, sensitivity can be improved more. Diffracted-light strength is strong and it can make into an OFF state the pixel of DMD13 to which it corresponds to the pixel with which the output of the photodetector 17 is saturated. It is possible for this to expand a dynamic range. It is good as for 0 in the coefficient of the filter matrix over the output from the pixel of the photodetector 17 with which it corresponds to the pixel of DMD13 made into the OFF state.

[0046]

Next, it describes about the inspection method of a defect, a foreign matter, etc. using the inspection apparatus 10. The system of the defect inspection concerning the present invention is a dark field scattered-light detection system. First, a wafer without a defect etc. is illuminated approximately perpendicularly from the light source 11. And light reception of the light which was diffracted by the pattern of this wafer and reflected by DMD13 is carried out with the photodetector 17. At this time, the diffracted light from the repeated pattern of a wafer makes the pixel of incident DMD13 an OFF state. That is, the strong diffracted light from the repeated pattern of a wafer carries out the mask of the pixel of the photodetector 17 of an incident portion by the pixel of DMD used as an OFF state. That is, you control DMD13 and the diffracted light from the pattern of the sample 30 makes it function as a spatial filter which intercepts an incident pixel. The diffracted light from the pattern of the sample 30 controls an incident pixel specifically to the direction by which the reflected light does not enter into the lens 14, and the reflected light controls the other pixel on the lens 14 at incident direction. Therefore, the diffracted light from the normal pattern of a wafer without a defect etc. is not detected with the photodetector 17.

[0047]

And while the diffracted light from a normal pattern has made the pixel of incident DMD13 the OFF state, it illuminates approximately perpendicularly from the light source 11 like the sample 30. The whole surface of the sample 30 is scanned and the map of the total of the luminous intensity which carried out light reception by the pixel of the photodetector 17 by which a mask is not carried out by the pixel of the OFF state of DMD13 is obtained. When a pattern defect or a foreign matter is on the sample 30, the lights scattered from the defect etc. are scattered about at the angle which deviated from the diffracted light from a pattern. For this reason, light reception of the scattered light from a defect etc. will be carried out with the photodetector 17. Therefore, a portion with large signal strength is judged to be a pattern defect or a foreign matter. As mentioned above, after scanning the whole surface of a semiconductor wafer, a peripheral circuit part and a region to be examined are separable using a projection or a histogram.

[0048]

Thus, according to the present invention, the inspection of the unevenness of a pattern and the inspection of a defect or a foreign matter are realizable with one set of inspection apparatus. By controlling ON/OFF of DMD13 arranged to the pupil position of a light-receiving system, a dynamic range can be made to be able to expand and inspection accuracy can be improved. The present invention is available to the visual inspection apparatus which inspects a semiconductor wafer, a photo mask for semiconductor memory and a liquid crystal display panel etc. which have a repeated pattern.

[0049]

Although described about the case where the unevenness of pattern line width is detected, in the above-mentioned description, it is not limited to this. For example, when change of diffracted-light strength is investigated with the pattern formed beforehand and the coefficient to which it corresponds to the diffracted light of the large degree of strength change chooses a large filter matrix, it is also possible to judge the classification of unevenness, such as film thickness of the resist formed on the substrate and change of a profile.

[0050]

In an above-mentioned embodiment, although DMD13 has been arranged to the Fourier transformation plane to the pattern of the sample 30, it is not limited to this. For example, it is also possible to use the liquid crystal optical switch etc. which can control the direction of a reflected light easily.

[Brief Description of the Drawings]

[0051]

A [FIG. 1] It is the figure showing the composition of the inspection apparatus 10 concerning an embodiment.

A [FIG. 2] It is the figure showing a state when moving the light-receiving system of the inspection apparatus 10 concerning an embodiment.

A [FIG. 3] It is a block diagram showing the composition of the processing unit 20 concerning an embodiment.

[Explanations of letters or numerals]

[0052]

10 Inspection apparatus
11 Light source
12, 14, and 16 Lens
13 DMD
15 Mirror
17 Photodetector
20 Processing unit
21 Scan control part
22 DMD control part
23 Defect decision part

24 Filter matrix selecting part
25 Calculating part
26 Unevenness judgment part
30 Sample
L01 Illumination light
L02, L03, and L04 Diffracted light

*** NOTICES ***

JPO and INPIT are not responsible for any damages caused by the use of this translation.

1. This document has been translated by computer. So the translation may not reflect the original precisely.
2. **** shows the word which can not be translated.
3. In the drawings, any words are not translated.

DRAWINGS

A [FIG. 1]

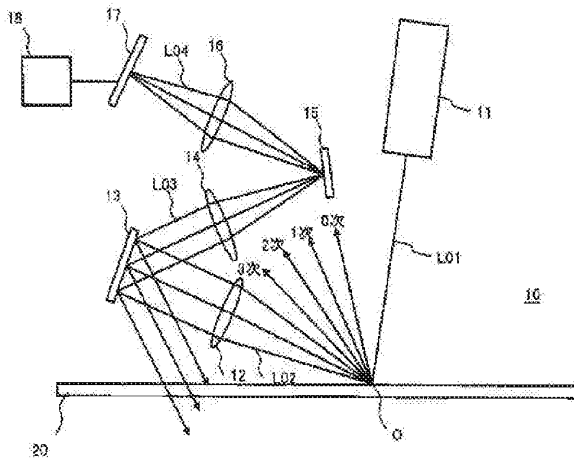

A [FIG. 2]

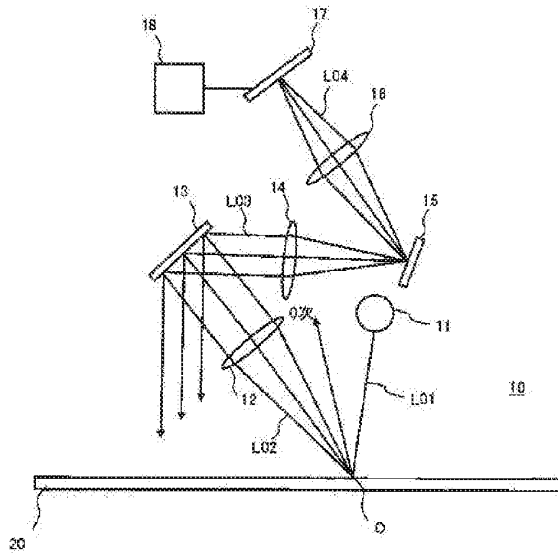

A [FIG. 3]

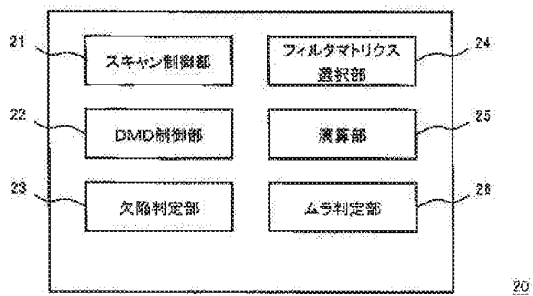

(19) 日本国特許庁 (JP)

(12) 公開特許公報 (A)

(11) 特許出願公開番号

特開2009-109263

(P2009-109263A)

(43) 公開日 平成21年5月21日 (2009. 5. 21)

(51) Int. Cl.	F I	テーマコード (参考)
GO 1 N 21/956 (2006. 01)	GO 1 N 21/956 A	2 F 0 6 5
GO 1 B 11/02 (2006. 01)	GO 1 B 11/02 G	2 G 0 5 1
HO 1 L 21/66 (2006. 01)	HO 1 L 21/66 J	4 M 1 0 6

審査請求 未請求 請求項の数 16 O L (全 12 頁)

(21) 出願番号 特願2007-280051 (P2007-280051)
 (22) 出願日 平成19年10月29日 (2007. 10. 29)

(71) 出願人 000115902
 レーザーテック株式会社
 神奈川県横浜市港北区新横浜2-10-1
 (74) 代理人 100103894
 弁理士 家入 健
 (74) 代理人 100129953
 弁理士 岩瀬 康弘
 (72) 発明者 楠瀬 治彦
 神奈川県横浜市港北区綱島東4-10-4
 レーザーテック株式会社内
 Fターム (参考) 2F065 AA22 BB02 FF41 FF48 GG00
 JJ00 JJ08 LL11 LL21
 2G051 AA51 AB02 BB01 CA01 CB01
 CB06 CC11 CC13 CD05 EB01
 EC01

最終頁に続く

(54) 【発明の名称】 検査装置及び検査方法

(57) 【要約】

【課題】 パターンのムラと、欠陥等の検査を1台の検査装置により実現すること。

【解決手段】 本発明の一態様にかかる検査装置10は、試料30上に形成されたパターンを検査する検査装置であって、試料30に照明光を照射する光源11と、試料30のパターンに対する光学的なフーリエ変換面に配置され、試料30からの回折光又は散乱光を反射するデジタルマイクロミラーデバイス (DMD) 13と、DMD 13と共役な位置に配置され、DMD 13で反射された光を受光する光検出器17とを備える。

【選択図】 図1

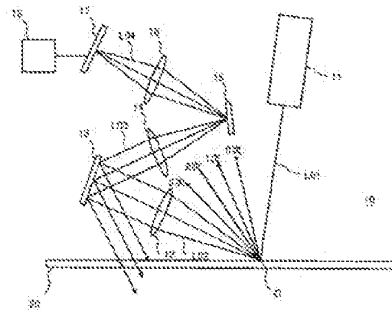

【特許請求の範囲】

【請求項 1】

試料上に形成されたパターンを検査する検査装置であって、
 前記試料に照明光を照射する光源と、
 前記試料のパターンに対する光学的なフーリエ変換面に配置され、前記試料からの回折光又は散乱光を反射するデジタルマイクロミラーデバイス（DMD）と、
 前記DMDと共役な位置に配置され、前記DMDで反射された光を受光する光検出器と、
 を備える検査装置。

【請求項 2】

前記光検出器は、複数の次数の回折光を受光し、
 当該複数の回折光の次数に応じて、受光する画素が異なっていることを特徴とする請求項 1 に記載の検査装置。

【請求項 3】

前記試料のパターンのムラを検査する場合には、
 前記複数の次数の回折光のうち、強度が大きい次数の回折光が入射する前記DMDの画素は、オフ状態であることを特徴とする請求項 2 に記載の検査装置。

【請求項 4】

前記試料のパターンのムラを検査する場合には、
 前記複数の次数の回折光のうち、ムラに起因した強度変化が大きい次数の回折光以外の次数の回折光が入射する前記DMDの画素は、オフ状態であることを特徴とする請求項 2 又は 3 に記載の検査装置。

【請求項 5】

前記光検出器で受光される前記複数の次数の回折光には、前記試料のパターンのムラの特徴を強調するように、次数に応じて異なる重み付け係数が設定されていることを特徴とする請求項 2 ～ 4 のいずれか 1 項に記載の検査装置。

【請求項 6】

前記光検出器で受光される前記複数の次数の回折光のそれぞれに、異なる重み付け係数が設定された複数のフィルタマトリクスを備える請求項 5 に記載の検査装置。

【請求項 7】

前記光検出器に入射する回折光の次数を変更できるように、前記DMD及び前記光検出器を含む受光系の前記試料に対する角度を変更することができる請求項 1 ～ 6 に記載の検査装置。

【請求項 8】

前記試料のパターンの欠陥を検査する場合には、
 前記DMDの前記試料のパターンからの回折光が照射されている画素は、オフ状態であることを特徴とする請求項 1 ～ 7 のいずれか 1 項に記載の検査装置。

【請求項 9】

試料上に形成されたパターンを検査する検査方法であって、
 前記試料に照明光を照射し、
 前記試料からの回折光又は散乱光を、前記試料のパターンに対する光学的なフーリエ変換面に配置されたデジタルマイクロミラーデバイス（DMD）で反射し、
 前記DMDで反射された光を、前記DMDと共役な位置に配置された光検出器で受光する検査方法。

【請求項 10】

前記光検出器は、複数の次数の回折光を受光し、
 当該複数の回折光の次数に応じて、異なる画素で受光する請求項 9 に記載の検査方法。

【請求項 11】

前記試料のパターンのムラを検査する場合には、前記複数の次数の回折光のうち、強度が大きい次数の回折光が入射する前記DMDの画素をオフ状態とすることを特徴とする請

10

20

30

40

50

求項 10 に記載の検査方法。

【請求項 12】

前記試料のパターンのムラを検査する場合には、前記複数の次数の回折光のうち、ムラに起因した強度変化が大きい次数の回折光以外の次数の回折光が入射する前記 DMD の画素をオフ状態とする請求項 10 又は 11 に記載の検査方法。

【請求項 13】

前記光検出器で受光される前記複数の次数の回折光には、前記試料のパターンのムラの特徴を強調するように、次数に応じて異なる重み付け係数を設定する請求項 10～12 のいずれか 1 項に記載の検査方法。

【請求項 14】

前記光検出器で受光される前記複数の次数の回折光のそれぞれに、異なる重み付け係数を用いて前記回折光の強度変化を強調する請求項 13 に記載の検査方法。

【請求項 15】

前記 DMD 及び前記光検出器を含む受光系の前記試料に対する位置を変更し、前記光検出器に入射する回折光の次数を変更する請求項 9～15 に記載の検査方法。

【請求項 16】

前記試料のパターンの欠陥を検査する場合には、前記 DMD の前記試料のパターンからの回折光が照射されている画素をオフ状態とすることを特徴とする請求項 9～15 のいずれか 1 項に記載の検査方法。

【発明の詳細な説明】

【技術分野】

【0001】

本発明は、半導体製造工程で利用されるウエハ、マスク等のパターンを検査するための検査装置及び検査方法に関する。

【背景技術】

【0002】

半導体製造工程で利用されるフォトマスクや半導体ウエハ等においては、基板上に所定のパターンが繰り返し形成されている。従来から、これらのマスク等（以下、「試料」という）の表面に形成された繰り返しパターンから発生する回折光（例えば 1 次回折光）を利用して、パターンのムラや異物、欠陥等を検査する検査装置が提案されている（例えば、特許文献 1 及び 2 参照）。試料表面の欠陥箇所と正常箇所では回折効率が異なるため、繰り返しパターンからの回折光に基づく画像には明るさの相違が現れ、その明暗により欠陥箇所を特定できる。

【0003】

また、特許文献 3 には、試料に形成されたパターンに合わせて照明方法を変更するため、対物レンズの瞳位置との共役点にミラーアレイデバイスを配置した検査装置が開示されている。特許文献 3 に記載の検査装置では、試料と共役な位置に撮像装置が配置されており、対物レンズにより投影された試料の像を撮像装置にて撮像することによりパターンの欠陥の検査を行っている。

【特許文献 1】特開平 10-232122 号公報

【特許文献 2】特開 2001-141657 号公報

【特許文献 3】特開 2006-23221 号公報

【発明の開示】

【発明が解決しようとする課題】

【0004】

従来は、欠陥あるいは異物検査の場合は、パターンからの回折光の角度以外の特定の角度範囲に散乱された光を検出していた。一方、パターン線幅のムラを検査する場合には、パターンからの回折光のうち、特定の次数の回折光の強度変化をモニタすることにより、パターン線幅のムラを検出していた。このため、パターンの欠陥と線幅のムラの検査とを 1 台の検査装置により実現することはできなかった。

10

20

30

40

50

【0005】

本発明は、このような事情を背景としてなされたものであり、本発明の目的は、パターン
のムラの検査と、欠陥あるいは異物等の検査とを1台の検査装置により実現することが
できる検査装置及び検査方法を提供することである。

【課題を解決するための手段】

【0006】

本発明の第1の態様に係る検査装置は、試料上に形成されたパターンを検査する検査装
置であって、前記試料に照明光を照射する光源と、前記試料のパターンに対する光学的な
フーリエ変換面に配置され、前記試料からの回折光又は散乱光を反射するデジタルマイク
ロミラーデバイス(DMD)と、前記DMDと共役な位置に配置され、前記DMDで反射
された光を受光する光検出器とを備えるものである。これにより、1台の装置でパターン
のムラ検査と、欠陥等の検査とを実現することができる。

10

【0007】

本発明の第2の態様に係る検査装置は、上記の検査装置において、前記光検出器は、複
数の次数の回折光を受光し、当該複数の回折光の次数に応じて、受光する画素が異なっ
ていることを特徴とするものである。これにより、ムラ等に起因する回折光強度の変化が大
きい次数の回折光を決定することができる。

【0008】

本発明の第3の態様に係る検査装置は、上記の検査装置において、前記試料のパターン
のムラを検査する場合には、前記複数の次数の回折光のうち、強度が大きい次数の回折光
が入射する前記DMDの画素は、オフ状態であることを特徴とするものである。これによ
り、検査感度を向上させることができる。

20

【0009】

本発明の第4の態様に係る検査装置は、上記の検査装置において、前記試料のパターン
のムラを検査する場合には、前記複数の次数の回折光のうち、ムラに起因した強度変化が
大きい次数の回折光以外の次数の回折光が入射する前記DMDの画素は、オフ状態であ
ることを特徴とするものである。これにより、検査感度を向上させることができる。

【0010】

本発明の第5の態様に係る検査装置は、上記の検査装置において、前記光検出器で受光
される前記複数の次数の回折光には、前記試料のパターンのムラの特徴を強調するように
、次数に応じて異なる重み付け係数が設定されていることを特徴とするものである。これ
により、検査感度を向上させることができる。

30

【0011】

本発明の第6の態様に係る検査装置は、上記の検査装置において、前記光検出器で受光
される前記複数の次数の回折光のそれぞれに、異なる重み付け係数が設定された複数のフ
ィルタマトリクスを備えるものである。これにより、必要に応じてフィルタマトリクスを
変更することができる。

【0012】

本発明の第7の態様に係る検査装置は、上記の検査装置において、前記光検出器に入射
する回折光の次数を変更できるように、前記DMD及び前記光検出器を含む受光系の前記
試料に対する角度を変更することができるものである。これにより、検査感度を向上させ
ることができる。

40

【0013】

本発明の第8の態様に係る検査装置は、上記の検査装置において、前記試料のパターンの
欠陥を検査する場合には、前記DMDの前記試料のパターンからの回折光が照射されてい
る画素は、オフ状態であることを特徴とするものである。これにより、試料の欠陥等の検
査を精度よく行うことができる。

【0014】

本発明の第9の態様に係る検査方法は、試料上に形成されたパターンを検査する検査方
法であって、前記試料に照明光を照射し、前記試料からの回折光又は散乱光を、前記試料

50

のパターンに対する光学的なフーリエ変換面に配置されたデジタルマイクロミラーデバイス(DMD)で反射し、前記DMDで反射された光を、前記DMDと共役な位置に配置された光検出器で受光する。これにより、パターンのムラの検査と、欠陥等の検査とを実現できる。

【0015】

本発明の第10の態様に係る検査方法は、上記の検査方法において、前記光検出器は、複数の次数の回折光を受光し、当該複数の回折光の次数に応じて、異なる画素で受光する。これにより、検査感度を高めることができる。

【0016】

本発明の第11の態様に係る検査方法は、上記の検査方法において、前記試料のパターンのムラを検査する場合には、前記複数の次数の回折光のうち、強度が大きい次数の回折光が入射する前記DMDの画素をオフ状態とすることを特徴とする。これにより、検査感度を向上させることができる。

10

【0017】

本発明の第12の態様に係る検査方法は、上記の検査方法において、前記試料のパターンのムラを検査する場合には、前記複数の次数の回折光のうち、ムラに起因した強度変化が大きい次数の回折光以外の次数の回折光が入射する前記DMDの画素をオフ状態とする。これにより、検査感度を向上させることができる。

【0018】

本発明の第13の態様に係る検査方法は、上記の検査方法において、前記光検出器で受光される前記複数の次数の回折光には、前記試料のパターンのムラの特徴を強調するように、次数に応じて異なる重み付け係数を設定する。これにより、検査感度を向上させることができる。

20

【0019】

本発明の第14の態様に係る検査方法は、上記の検査方法において、前記光検出器で受光される前記複数の次数の回折光のそれぞれに、異なる重み付け係数を用いて前記回折光の強度変化を強調する。これにより、検査感度を向上させることができる。

【0020】

本発明の第15の態様に係る検査方法は、上記の検査方法において、前記DMD及び前記光検出器を含む受光系の前記試料に対する位置を変更し、前記光検出器に入射する回折光の次数を変更する。これにより、検査感度を向上させることができる。

30

【0021】

本発明の第16の態様に係る検査方法は、上記の検査方法において、前記試料のパターンの欠陥を検査する場合には、前記DMDの前記試料のパターンからの回折光が照射されている画素をオフ状態とする。これにより、試料の欠陥等の検査を精度よく行うことができる。

【発明の効果】**【0022】**

本発明によれば、パターンのムラの検査と、欠陥あるいは異物等の検査とを1台の検査装置により実現することができる検査装置及び検査方法を提供することができる。

40

【発明を実施するための最良の形態】**【0023】**

以下、本発明の実施の形態について図面を参照して説明する。以下の説明は、本発明の好適な実施の形態を示すものであって、本発明の範囲が以下の実施例の形態に限定されるものではない。以下の説明において、同一の符号が付されたものは実質的に同様の内容を示している。

【0024】

本発明の実施の形態に係る検査装置について、図1を参照して説明する。図1は、検査装置10の基本構成を示した図である。本実施の形態に係る検査装置10は、基板上に繰り返しパターンが形成された試料の欠陥あるいは異物の検査及びパターンの線幅のムラの

50

検査を行うものである。なお、パターンの中のムラとは、欠陥検査等のミクロ検査では良品と判定されても、パターンの僅かな寸法ズレが発生し、目視によるマクロ検査で不良品として判断されるものである。

【0025】

以下の説明では、ウエハ上に繰り返しパターンが形成された試料30を検査する検査装置を例として説明する。また、繰り返しパターンは、一方向に長く平行なラインとスペース（凹部と凸部）が一定間隔で配列されたL/S（ライン・アンド・スペース）パターンとする。しかしながら、本発明はこれに限定されるものではなく、フォトマスクや液晶表示パネルなどのパターン検査にも適用可能である。

【0026】

図1に示すように、検査装置10は、光源11、レンズ12、14、16、デジタルマイクロミラーデバイス（DMD）13、ミラー15、光検出器17、処理装置20を備えている。ムラの検査を行う場合には、本実施の形態に係る検査装置10は、試料30上に形成された繰り返しパターンにコヒーレント光を照射し、レンズによって得られるフーリエ変換面における回折光パターン（フーリエパターン）の解析を行うことにより、パターンのムラの検査を行う。一方、欠陥、異物等の検査を行う場合は、試料30のパターンによる回折光を検出しないようにして、欠陥等からの散乱光を検出することにより行われる。

10

【0027】

なお、ここでは図示していないが、試料30は、X-Yステージ上に吸着固定されている。X-Yステージをモーター等により駆動させることにより、光源11から出射される光ビームにより、試料30上をスキャンすることができる。

20

【0028】

光源11は、試料30にコヒーレント光である照明光L01を出射する。光源11としては、コヒーレントな光を出射するレーザー等を用いることができる。例えば、波長405nmのレーザー光を、試料30に対してほぼ垂直に落射照明する。本実施の形態では、照明光L01のビーム径としては、例えば、0.2~0.3mmとする。照明光L01の光ビーム内に、試料30のパターンが10個程度入ることとなる。なお、本発明においては、試料30に略平行光を照射しているため、フォーカス位置に関係なく精度よくムラ等の検査を行うことができる。

30

【0029】

試料30上の繰り返しパターンのピッチをd、照明光の入射角と θ_i 、回折光の次数がmの場合の回折角を θ_m 、入射光の波長を λ とすると、以下の式が成り立つことが一般的に知られている。

$$d(\sin\theta_m \pm \sin\theta_i) = m\lambda \quad (m=0, \pm 1, \dots)$$

ここで、0次回折光（直接光）は、微細な欠陥情報が相対的に少ない。このため、0次回折光よりも絶対値の大きな次数の回折光を検出する必要がある。従って、図1に示すように、ここでは、4次~6次の回折光がレンズ12に入射するようにする。試料30の繰り返しパターンからの回折光L02は互いに干渉しあい、レンズ12を通過することにより、フーリエ変換面に繰り返し周期に依存した回折光パターン（フーリエパターン）が形成される。

40

【0030】

なお、上記の式から分かるように、繰り返しパターンのピッチdにより、回折次数mと回折角度 θ_m は変動する。また、図1の例では、4次~6次の回折光がレンズ12に入射するようにしているが、より低い次数（1次~3次）のほうがより感度よく検査できる場合、あるいは、高い次数のほうがより感度よく検査できる場合がある。このため、図2に示すように、DMD13、光検出器17等の受光系は、試料30の検査領域Oを中心として回転可能に設けられている。すなわち、DMD13、光検出器17等を含む受光系は、試料30に対する角度を変更可能に設けられている。これにより、受光する回折光の次数を選択することができ、より感度よく試料30の検査を行うことが可能である。なお、図

50

2においては、受光系と光源11とが干渉しないように、例えば、光源11から出射される照明光L01をミラー等で曲げて、試料30に照射するようにしてもよい。

【0031】

試料30のパターンに対する光学的なフーリエ変換面には、DMD13が配置されている。すなわち、DMD13は、受光系の瞳位置に配置されている。従って、試料30の繰り返しパターンによる回折光パターンが、DMD13上に形成される。DMD13は、多数の微小鏡面（マイクロミラー）を平面に配列した構成を有している。DMD13としては、例えば、テキサス・インスツルメンツ社製のものを用いることができる。各マイクロミラーは、それぞれ画素に対応する。DMD13は、画素ごとに各マイクロミラーのオン／オフを高速に制御できる反射ミラーとして用いられる。DMD13の各マイクロミラーを、その反射光がレンズ14に入射する向きに制御した状態がオン状態、レンズ14に入射しない向きに制御した状態がオフ状態である。従って、マイクロミラーがオンのときには、試料30からの回折光はレンズ14に入射する方向に反射される。一方、マイクロミラーがオフのときには、試料30からの回折光はレンズ14に入射しない方向へ反射される。

10

【0032】

DMD13によってレンズ14側に反射された回折光L03は、レンズ14に入射し、ミラー15に集光される。ミラー15によって反射された光L04は、レンズ16を通過して光検出器17に入射する。光検出器17は、DMD13で反射された光を受光し、電気的な信号に変換する。光検出器17は、DMD13と共役な位置に配置されている。すなわち、DMD13と光検出器17とは、いずれも受光系の瞳位置に配置されている。光検出器17としては、例えば、1次元のNMOSラインセンサを用いることが好適である。

20

【0033】

上述したように本実施の形態においては、試料30に形成されたパターンは、ライン・アンド・スペースパターンである。このため、試料30のパターンによる複数の次数の回折光は、それぞれ特定の方向に進む。光検出器17の画素は、試料30のパターンからの複数の次数の回折光が出ている方向に配列される。また、DMD13の画素と光検出器17の画素とがそれぞれ対応するように配置される。すなわち、ある次数の回折光は、DMD13の特定の画素で反射され、光検出器17の特定の画素で検出される。光検出器17によって検出された複数の次数の回折光の強度変化を測定することにより、ムラ検査を行う。例えば、基準となるリファレンスのパターンからの回折光強度と、測定した試料30のパターンからの回折光強度との差に基づいて、パターン線幅のムラを検査する。このように、ラインセンサを回折光が出ている方向に配列することにより受光画素が少なく済むため、検査速度を早くすることができる。なお、光検出器17として、2次元CCD素子を用いたエリアセンサなどを使用することも可能である。

30

【0034】

一方、欠陥あるいは異物検査を行う場合には、試料30のパターンからの回折光が投影される位置のDMD13の画素をオフ状態とする。これにより、光検出器17には、試料30のパターンによる回折光は入射しない。このため、パターン以外の欠陥あるいは異物等がある場合には、当該欠陥等による散乱光がオン状態となっているDMD13の画素でレンズ14の方向へ反射される。従って、欠陥等による散乱光が、光検出器17で検出され、欠陥等の検査が行われる。

40

【0035】

処理装置20に、光検出器17で受光された光に対応する信号が供給される。図3に、処理装置20の構成を模式的に示す。図3に示すように、処理装置20は、スキャン制御部21、DMD制御部22、欠陥判定部23、フィルタマトリクス選択部24、演算部25、ムラ判定部26を備えている。スキャン制御部21は、試料30が載置されるステージと、光源11から照射される光の相対位置を制御する。DMD制御部22は、DMD13の各画素のオン／オフを切替える。欠陥判定部23は、欠陥あるいは異物等を検査する

50

場合に、光検出器 17 により受光された光信号に基づいて、欠陥の有無を判定する。

【0036】

フィルタマトリクス選択部 24 には、各次数の回折光に対する重み付けのための複数のフィルタマトリクスが設定されている。フィルタマトリクス選択部 24 では、光検出器 17 からの光信号に基づいて、最適なフィルタマトリクスが選択される。例えば、ムラの検出を行う場合に、線幅に対して強度変化の大きい次数の回折光に対し重み付けを行うため、係数が大きいフィルタマトリクスが選択される。また、光検出器 17 に入射する回折光の 1 つが強すぎて飽和してしまうような場合には、当該回折光に対応する光検出器 17 の画素からの信号に対応する係数が 0 のものを選択することができる。これにより、受光レンズを拡大することができ、より高感度にムラの検出を行うことができる。演算部 25 は、フィルタマトリクス選択部 24 において選択されたフィルタマトリクスを用いて、演算処理を行う。ムラ判定部 26 は、演算部 25 において重み付けされた信号に基づいて、試料 30 のムラの判定を行う。

10

【0037】

ここで、上述の検査装置 10 を用いた試料 30 の検査方法について説明する。上述したように、本実施の形態に係る検査装置 10 は、試料 30 に形成されたパターンのムラの検査と、欠陥あるいは異物等の検査を 1 台の装置で実現するものである。まず、試料 30 のパターンをムラを検査する方法について説明する。本発明に係るムラ検出方式は、フーリエパターンの特徴抽出である。

【0038】

まず、最初にフィルタマトリクスの設定を行う。フィルタマトリクスは、複数設定することが可能である。フィルタマトリクスの設定方法について、(1) CD (critical dimension) を振ったサンプルウエハがある場合、(2) CD を振ったサンプルウエハがない場合に分けて説明する。

20

(1) CD を振ったサンプルウエハがある場合

初めに、ショット間でわずかにドーズ (露光量) を変化させて露光したサンプルウエハを準備する。ウエハ上にポジ型のレジストが形成されているとすると、ドーズを変化させることにより、現像した後のパターン線幅が変わる。

【0039】

そして、サンプルウエハの全面をスキャンし、回折光強度のデータを取り込む。このとき、DMD 13 の全画素はオン状態とする。そして、パターン線幅が異なるダイを指定して、パターンを比較する。これらの回折光強度の差を取ると、特定の次数の回折光で差が大きくなる。従って、この次数の回折光の強度変化を監視することにより、感度よくムラ検査を行うことができる。この次数の回折光が入射する光検出器 17 の画素からのデータに対し重み付けを行うためのフィルタマトリクスを設定する。すなわち、パターン線幅のエラーの特徴を強調するフィルタマトリクスを自動的に決定する。

30

【0040】

パターン線幅が変化すると、ある次数の回折光強度が大きく強くなる場合、あるいは、弱くなる場合がある。従って、このように変化の大きい回折光に対して、その変化を強調するように、正又は負の係数をかける。例えば、4 次の回折光強度がパターン線幅を変えても変化しないような場合には、当該 4 次の回折光に対する係数を 0 にする。また、5 次の回折光強度がパターン線幅を変えると大きく変化する場合には、当該 5 次の回折光にそれに相当する大きな係数をかける。これにより、受光レンズを拡大することができ、検査感度を向上させることができる。

40

【0041】

(2) CD を振ったサンプルウエハがない場合

回折光の各次数からの回折光の強度マップを作成する。すなわち、光検出器 17 の各画素で受光される試料 30 からの回折光の強度分布を求める。さらに、各回折光の強度マップ間の和、差などを補助的に利用して、異常領域と正常領域をマニュアルで検出する。つまり、回折光強度が試料 30 の他の観察領域と比較して変化していない領域を正常領域と

50

し、変化している領域を異常領域と判定する。そして、上述のように、異常領域の特徴を強調するようなフィルタマトリクスを自動的に設定する。

【0042】

上述のようにフィルタマトリクスを決定した後に、実際の試料30のムラ検査を行う。具体的には、まず試料30及びリファレンスウエハの全面をスキャンし、それぞれの回折光パターンを取り込む。そして、試料30の回折光強度と、リファレンスウエハの回折光強度との差を求める。その後、処理装置20のフィルタマトリクス選択部24で選択されたフィルタマトリクスを用いて演算処理を行い、検出すべき特徴を強調する。そして、ムラ判定部26において、リファレンスからの回折光強度の差が大きい部分、特異点等を異常箇所と判断する。このように、本発明では、リファレンスウエハと試料30の回折光強度を比較するため、従来のDie to Dieや、Die to Databaseの検査法と比較すると、アライメント誤差の影響が少ない。

10

【0043】

なお、実際の半導体ウエハの場合、周辺回路部と検査対象領域である繰り返しパターン領域がある。従って、半導体ウエハの全面をスキャンした後、フィルタ処理を行う前に、プロジェクションあるいはヒストグラム等を利用して、周辺回路部と検査対象領域とを分離することができる。また、リファレンスウエハの回折光パターンを取り込む際に、特定の次数の回折光強度が強すぎて、対応する光検出器17の画素の飽和してしまう場合がある。この場合には、対応するDMD13の画素をオフ状態とし、フィルタマトリクスの係数を0とすることができる。この場合には、試料30の検査を行う際にも当該DMD13の画素をオフ状態としたまま、試料30のムラ検査を開始する。また、リファレンスの回折光パターンを測定する際に光検出器17の感度を変更して飽和しない状態とし、この状態で試料30の回折光パターンを測定するようにしてもよい。

20

【0044】

また、光検出器17に複数の次数の回折光を入射させ、ムラに起因した強度変化が大きい次数の回折光を決定し、当該次数の回折光以外の次数の回折光が入射するDMD13の画素をオフ状態としてもよい。

【0045】

このように、本発明によれば、ムラに起因する回折光強度の変化が大きく、感度の高い次数の回折光を用いてムラの検査を行う。このため、非常に敏感なムラ検査を行うことができる。また、フィルタマトリクスにより、特定の次数の回折光強度に大きな値の係数をかけることができるため、より感度を向上させることができる。さらに、回折光強度が強く、光検出器17の出力が飽和してしまう画素に対応するDMD13の画素をオフ状態にすることができる。これにより、ダイナミックレンジを拡大することが可能である。なお、オフ状態としたDMD13の画素に対応する光検出器17の画素からの出力に対するフィルタマトリクスの係数を0にしてもよい。

30

【0046】

次に、検査装置10を用いた欠陥、異物等の検査方法について説明する。本発明に係る欠陥検査の方式は、暗視野散乱光検出方式である。まず、欠陥等のないウエハを光源11から略垂直に照明する。そして、このウエハのパターンで回折され、DMD13で反射された光を光検出器17で受光する。このとき、ウエハの繰り返しパターンからの回折光が入射するDMD13の画素をオフ状態とする。すなわち、ウエハの繰り返しパターンからの強い回折光が入射する部分の光検出器17の画素を、オフ状態となっているDMDの画素によりマスクする。つまり、DMD13を制御して、試料30のパターンからの回折光が入射する画素を遮断する空間フィルタとして機能させる。具体的には、試料30のパターンからの回折光が入射する画素を、その反射光がレンズ14に入射しない向きに制御し、それ以外の画素をその反射光がレンズ14に入射する向きに制御する。従って、欠陥等のないウエハの正常なパターンからの回折光は、光検出器17で検出されない。

40

【0047】

そして、正常なパターンからの回折光が入射するDMD13の画素をオフ状態としたま

50

ま、試料 30 に同様に光源 11 から略垂直に照明する。試料 30 の全面をスキャンし、DMD 13 のオフ状態の画素でマスクされていない光検出器 17 の画素で受光した光の強度の総和のマップを得る。パターン欠陥あるいは異物が試料 30 上にある場合、欠陥等から散乱された光は、パターンからの回折光とずれた角度で散乱される。このため、欠陥等からの散乱光が、光検出器 17 で受光されることとなる。従って、信号強度が大きい部分をパターン欠陥又は異物と判定する。なお、上述したように、半導体ウエハの全面をスキャンした後に、プロジェクションあるいはヒストグラム等を利用して、周辺回路部と検査対象領域とを分離することができる。

【0048】

このように、本発明によれば、1台の検査装置で、パターンのムラの検査と、欠陥あるいは異物等の検査とを実現することができる。また、受光系の瞳位置に配置したDMD 13のオン/オフを制御することにより、ダイナミックレンジを拡大させることができ、検査精度を向上させることができる。本発明は、繰り返しパターンを有する半導体ウエハや半導体メモリ用フォトマスク、液晶表示パネルなどを検査する外観検査装置に利用可能である。

10

【0049】

なお、上述の説明では、パターン線幅のムラを検出する場合について説明したが、これに限定されるものではない。例えば、あらかじめ形成したパターンにより回折光強度の変化を調べておき、強度変化の大きい次数の回折光に対応する係数が大きいフィルタマトリクスを選択することにより、基板上に形成したレジストの膜厚や、プロファイルの変化等ムラの種別を判定することも可能である。

20

【0050】

また、上述の実施の形態では、試料 30 のパターンに対するフーリエ変換面に DMD 13 を配置したが、これに限定されるものではない。例えば、反射光の方向を容易にコントロールすることができる液晶光スイッチ等を用いることも可能である。

【図面の簡単な説明】

【0051】

【図 1】実施の形態に係る検査装置 10 の構成を示す図である。

【図 2】実施の形態に係る検査装置 10 の受光系を移動させたときの状態を示す図である。

30

【図 3】実施の形態に係る処理装置 20 の構成を示すブロック図である。

【符号の説明】

【0052】

- 10 検査装置
- 11 光源
- 12、14、16 レンズ
- 13 DMD
- 15 ミラー
- 17 光検出器
- 20 処理装置
- 21 スキャン制御部
- 22 DMD制御部
- 23 欠陥判定部
- 24 フィルタマトリクス選択部
- 25 演算部
- 26 ムラ判定部
- 30 試料
- L01 照明光
- L02、L03、L04 回折光

40

【図 1】

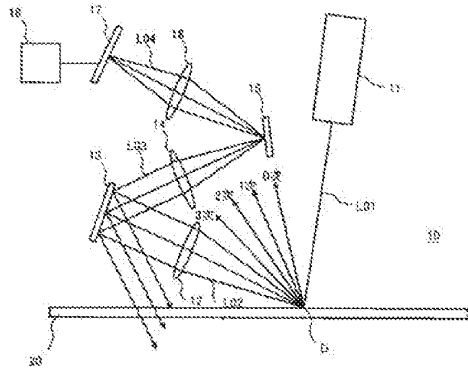

【図 2】

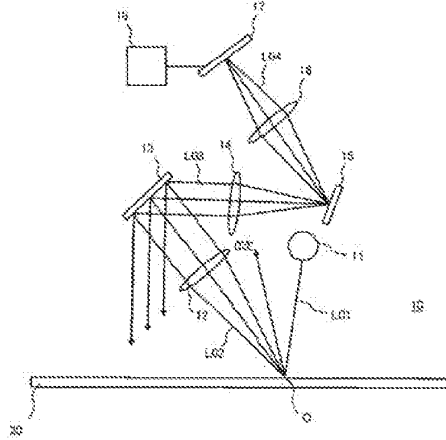

【図 3】

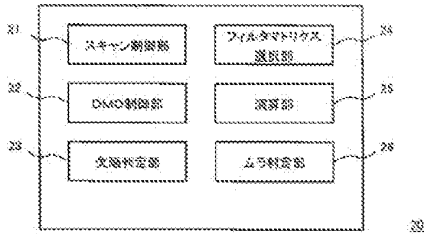

フロントページの続き

Fターム(参考) 4M106 AA01 AA09 CA39 CA41 DB04 DB08 DB12 DB13 DB19 DJ04
DJ20

Electronic Patent Application Fee Transmittal				
Application Number:	14764087			
Filing Date:	28-Jul-2015			
Title of Invention:	FOCUS SCANNING APPARATUS RECORDING COLOR			
First Named Inventor/Applicant Name:	Bo ESBECH			
Filer:	Travis Dean Boone/Snjezana Gvozderac			
Attorney Docket Number:	00791 24-000111			
Filed as Large Entity				
Filing Fees for U.S. National Stage under 35 USC 371				
Description	Fee Code	Quantity	Amount	Sub-Total in USD(\$)
Basic Filing:				
Pages:				
Claims:				
Miscellaneous-Filing:				
Petition:				
Patent-Appeals-and-Interference:				
Post-Allowance-and-Post-Issuance:				
Extension-of-Time:				

Description	Fee Code	Quantity	Amount	Sub-Total in USD(\$)
Miscellaneous:				
Submission- Information Disclosure Stmt	1806	1	240	240
Total in USD (\$)				240

Electronic Acknowledgement Receipt	
EFS ID:	32154961
Application Number:	14764087
International Application Number:	
Confirmation Number:	6247
Title of Invention:	FOCUS SCANNING APPARATUS RECORDING COLOR
First Named Inventor/Applicant Name:	Bo ESBECH
Customer Number:	21839
Filer:	Travis Dean Boone/Snjezana Gvozderac
Filer Authorized By:	Travis Dean Boone
Attorney Docket Number:	00791 24-000111
Receipt Date:	26-MAR-2018
Filing Date:	28-JUL-2015
Time Stamp:	14:01:53
Application Type:	U.S. National Stage under 35 USC 371

Payment information:

Submitted with Payment	yes
Payment Type	CARD
Payment was successfully received in RAM	\$240
RAM confirmation Number	032718INTEFSW14024200
Deposit Account	024800
Authorized User	Snjezana Gvozderac
The Director of the USPTO is hereby authorized to charge indicated fees and credit any overpayment as follows: 37 CFR 1.17 (Patent application and reexamination processing fees) 37 CFR 1.19 (Document supply fees)	

37 CFR 1.20 (Post Issuance fees)					
37 CFR 1.21 (Miscellaneous fees and charges)					
37 CFR 1.492 (National application filing, search, and examination fees)					
37 CFR 1.492(a) (Basic national fee only)					
File Listing:					
Document Number	Document Description	File Name	File Size(Bytes)/ Message Digest	Multi Part /.zip	Pages (if appl.)
1	Information Disclosure Statement (IDS) Form (SB08)	PTO_SP08.pdf	612294 6e855e8025191ec349523cbd7c88584257574fe	no	4
Warnings:					
Information:					
A U.S. Patent Number Citation or a U.S. Publication Number Citation is required in the Information Disclosure Statement (IDS) form for autoloading of data into USPTO systems. You may remove the form to add the required data in order to correct the Informational Message if you are citing U.S. References. If you chose not to include U.S. References, the image of the form will be processed and be made available within the Image File Wrapper (IFW) system. However, no data will be extracted from this form. Any additional data such as Foreign Patent Documents or Non Patent Literature will be manually reviewed and keyed into USPTO systems.					
2	Foreign Reference	F1_JP2007117152.pdf	535249 4d081eb3b6c7b3573c2a372060dac62844329299	no	17
Warnings:					
Information:					
3	Foreign Reference	F2_JP2009109263.pdf	589294 80d26d70f86e3484ea83c75be4f75b25d51f2b7f5	no	24
Warnings:					
Information:					
4	Other Reference-Patent/App/Search documents	JPOA_01092018.pdf	669650 1df6e9851ca958641c6079105caa87e52f496e7	no	8
Warnings:					
Information:					
5	Fee Worksheet (SB06)	fee-info.pdf	30645 ed106f67e9614bd0c15985d2051f315e67eb990	no	2
Warnings:					
Information:					
Total Files Size (in bytes):			2437132		

This Acknowledgement Receipt evidences receipt on the noted date by the USPTO of the indicated documents, characterized by the applicant, and including page counts, where applicable. It serves as evidence of receipt similar to a Post Card, as described in MPEP 503.

New Applications Under 35 U.S.C. 111

If a new application is being filed and the application includes the necessary components for a filing date (see 37 CFR 1.53(b)-(d) and MPEP 506), a Filing Receipt (37 CFR 1.54) will be issued in due course and the date shown on this Acknowledgement Receipt will establish the filing date of the application.

National Stage of an International Application under 35 U.S.C. 371

If a timely submission to enter the national stage of an international application is compliant with the conditions of 35 U.S.C. 371 and other applicable requirements a Form PCT/DO/EO/903 indicating acceptance of the application as a national stage submission under 35 U.S.C. 371 will be issued in addition to the Filing Receipt, in due course.

New International Application Filed with the USPTO as a Receiving Office

If a new international application is being filed and the international application includes the necessary components for an international filing date (see PCT Article 11 and MPEP 1810), a Notification of the International Application Number and of the International Filing Date (Form PCT/RO/105) will be issued in due course, subject to prescriptions concerning national security, and the date shown on this Acknowledgement Receipt will establish the international filing date of the application.

PART B - FEE(S) TRANSMITTAL

Complete and send this form, together with applicable fee(s), to: **Mail Stop ISSUE FEE
Commissioner for Patents
P.O. Box 1450
Alexandria, Virginia 22313-1450**
or Fax **(571)-273-2885**

INSTRUCTIONS: This form should be used for transmitting the ISSUE FEE and PUBLICATION FEE (if required). Blocks 1 through 5 should be completed where appropriate. All further correspondence including the Patent, advance orders and notification of maintenance fees will be mailed to the current correspondence address as indicated unless corrected below or directed otherwise in Block 1, by (a) specifying a new correspondence address; and/or (b) indicating a separate "FEE ADDRESS" for maintenance fee notifications.

CURRENT CORRESPONDENCE ADDRESS (Note: Use Block 1 for any change of address)

21839 2590 03/28/2017
**BUCHANAN, INGERSOLL & ROONEY PC
POST OFFICE BOX 1404
ALEXANDRIA, VA 22313-1404**

Note: A certificate of mailing can only be used for domestic mailings of the Fee(s) Transmittal. This certificate cannot be used for any other accompanying papers. Each additional paper, such as an assignment or formal drawing, must have its own certificate of mailing or transmission.

Certificate of Mailing or Transmission

I hereby certify that this Fee(s) Transmittal is being deposited with the United States Postal Service with sufficient postage for first class mail in an envelope addressed to the Mail Stop ISSUE FEE address above, or being facsimile transmitted to the USPTO (571) 273-2885, on the date indicated below.

_____ (Depositor's name)
_____ (Signature)
_____ (Date)

APPLICATION NO.	FILING DATE	FIRST NAMED INVENTOR	ATTORNEY DOCKET NO.	CONFIRMATION NO.
14/764,087	03/28/2015	Bo ESBECH	0079124-000111	6247

TITLE OF INVENTION: FOCUS SCANNING APPARATUS RECORDING COLOR

APPL. TYPE	ENTITY STATUS	ISSUE FEE DUE	PUBLICATION FEE DUE	PREV. PAID ISSUE FEE	TOTAL FEE(S) DUE	DATE DUE
nonprovisional	UNDISCOUNTED	\$960	\$0	\$0	\$960	03/28/2018

EXAMINER	ART UNIT	CLASS-SUBCLASS
PYO, KEVIN K	2878	250-208100

1. Change of correspondence address or indication of "Fee Address" (37 CFR 1.363)

- Change of correspondence address for Change of Correspondence Address form PTO/SB/122 attached.
- "Fee Address" indication (or "Fee Address" Indication form PTO/SB/47; Rev 03-02 or more recent) attached. Use of a Customer Number is required.

2. For printing on the patent front page, list

- (1) The names of up to 3 registered patent attorneys or agents OR, alternatively,
- (2) The name of a single firm (having as a member a registered attorney or agent) and the names of up to 2 registered patent attorneys or agents. If no name is listed, no name will be printed.

1 **BUCHANAN INGERSOLL
& ROONEY P.C.**

3. ASSIGNEE NAME AND RESIDENCE DATA TO BE PRINTED ON THE PATENT (print or type)

PLEASE NOTE: Unless an assignee is identified below, no assignee data will appear on the patent. If an assignee is identified below, the document has been filed for recordation as set forth in 37 CFR 3.11. Completion of this form is NOT a substitute for filing an assignment.

(A) NAME OF ASSIGNEE

3SHAPE A/S

(B) RESIDENCE: (CITY and STATE OR COUNTRY)

Kobenhavn K, DENMARK

Please check the appropriate assignee category or categories (will not be printed on the patent): Individual Corporation or other private group entity Government

4a. The following fee(s) are submitted:

- Issue Fee
- Publication Fee (No small entity discount permitted)
- Advance Order - # of Copies _____

4b. Payment of Fee(s): (Please first reapply any previously paid issue fee shown above)

- A check is enclosed.
- Payment by credit card. Form PTO-2038 is attached.
- The director is hereby authorized to charge the required fee(s), any deficiency, or credits any overpayment, to Deposit Account Number 02-4800 (enclose an extra copy of this form).

5. Change in Entity Status (from status indicated above)

- Applicant certifying micro entity status. See 37 CFR 1.29
- Applicant asserting small entity status. See 37 CFR 1.27
- Applicant changing to regular undiscounted fee status.

NOTE: Absent a valid certification of Micro Entity Status (see forms PTO/SB/15A and 15B), issue fee payment in the micro entity amount will not be accepted at the risk of application abandonment.

NOTE: If the application was previously under micro entity status, checking this box will be taken to be a notification of loss of entitlement to micro entity status.

NOTE: Checking this box will be taken to be a notification of loss of entitlement to small or micro entity status, as applicable.

NOTE: This form must be signed in accordance with 37 CFR 1.31 and 1.33. See 37 CFR 1.4 for signature requirements and certifications.

Authorized Signature /Travis D. Boone/

Date 28 March 2018

Typed or printed name Travis D. Boone

Registration No. 52,635

Electronic Patent Application Fee Transmittal				
Application Number:	14764087			
Filing Date:	28-Jul-2015			
Title of Invention:	FOCUS SCANNING APPARATUS RECORDING COLOR			
First Named Inventor/Applicant Name:	Bo ESBECH			
Filer:	Travis Dean Boone/Denise Williams			
Attorney Docket Number:	0079124-000111			
Filed as Large Entity				
Filing Fees for U.S. National Stage under 35 USC 371				
Description	Fee Code	Quantity	Amount	Sub-Total in USD(\$)
Basic Filing:				
Pages:				
Claims:				
Miscellaneous-Filing:				
Petition:				
Patent-Appeals-and-Interference:				
Post-Allowance-and-Post-Issuance:				
UTILITY APPL ISSUE FEE	1501	1	960	960

Description	Fee Code	Quantity	Amount	Sub-Total in USD(\$)
Extension-of-Time:				
Miscellaneous:				
Total in USD (\$)				960

Electronic Acknowledgement Receipt	
EFS ID:	32177608
Application Number:	14764087
International Application Number:	
Confirmation Number:	6247
Title of Invention:	FOCUS SCANNING APPARATUS RECORDING COLOR
First Named Inventor/Applicant Name:	Bo ESBECH
Customer Number:	21839
Filer:	Travis Dean Boone/Denise Williams
Filer Authorized By:	Travis Dean Boone
Attorney Docket Number:	00791 24-000111
Receipt Date:	28-MAR-2018
Filing Date:	28-JUL-2015
Time Stamp:	10:16:10
Application Type:	U.S. National Stage under 35 USC 371

Payment information:

Submitted with Payment	yes
Payment Type	CARD
Payment was successfully received in RAM	\$960
RAM confirmation Number	032818INTEFSW10163400
Deposit Account	024800
Authorized User	Denise Miles
<p>The Director of the USPTO is hereby authorized to charge indicated fees and credit any overpayment as follows:</p> <p>37 CFR 1.17 (Patent application and reexamination processing fees)</p> <p>37 CFR 1.19 (Document supply fees)</p>	

37 CFR 1.20 (Post Issuance fees)
 37 CFR 1.21 (Miscellaneous fees and charges)
 37 CFR 1.492 (National application filing, search, and examination fees)
 37 CFR 1.492(a) (Basic national fee only)

File Listing:

Document Number	Document Description	File Name	File Size(Bytes)/ Message Digest	Multi Part /.zip	Pages (if appl.)
1	Issue Fee Payment (PTO-85B)	18_03_28_Issue_Fee_Transmittal.pdf	313539 f5380c0ba2e9af6cc6e4e83d052e75402cbdcc31	no	1

Warnings:

Information:

2	Fee Worksheet (SB06)	fee-info.pdf	30548 68a29bd99cc31c54f3a90aa65aad1d2e48935a2f	no	2
---	----------------------	--------------	---	----	---

Warnings:

Information:

Total Files Size (in bytes):			344087
-------------------------------------	--	--	--------

This Acknowledgement Receipt evidences receipt on the noted date by the USPTO of the indicated documents, characterized by the applicant, and including page counts, where applicable. It serves as evidence of receipt similar to a Post Card, as described in MPEP 503.

New Applications Under 35 U.S.C. 111

If a new application is being filed and the application includes the necessary components for a filing date (see 37 CFR 1.53(b)-(d) and MPEP 506), a Filing Receipt (37 CFR 1.54) will be issued in due course and the date shown on this Acknowledgement Receipt will establish the filing date of the application.

National Stage of an International Application under 35 U.S.C. 371

If a timely submission to enter the national stage of an international application is compliant with the conditions of 35 U.S.C. 371 and other applicable requirements a Form PCT/DO/EO/903 indicating acceptance of the application as a national stage submission under 35 U.S.C. 371 will be issued in addition to the Filing Receipt, in due course.

New International Application Filed with the USPTO as a Receiving Office

If a new international application is being filed and the international application includes the necessary components for an international filing date (see PCT Article 11 and MPEP 1810), a Notification of the International Application Number and of the International Filing Date (Form PCT/RO/105) will be issued in due course, subject to prescriptions concerning national security, and the date shown on this Acknowledgement Receipt will establish the international filing date of the application.



UNITED STATES PATENT AND TRADEMARK OFFICE

UNITED STATES DEPARTMENT OF COMMERCE
United States Patent and Trademark Office
Address: COMMISSIONER FOR PATENTS
P.O. Box 1450
Alexandria, Virginia 22313-1450
www.uspto.gov

Table with 5 columns: APPLICATION NO., FILING DATE, FIRST NAMED INVENTOR, ATTORNEY DOCKET NO., CONFIRMATION NO.
14/764,087 07/28/2015 Bo ESBECH 0079124-000111 6247

21839 7590 04/09/2018
BUCHANAN, INGERSOLL & ROONEY PC
POST OFFICE BOX 1404
ALEXANDRIA, VA 22313-1404

EXAMINER

PYO, KEVIN K

ART UNIT PAPER NUMBER

2878

NOTIFICATION DATE DELIVERY MODE

04/09/2018

ELECTRONIC

Please find below and/or attached an Office communication concerning this application or proceeding.

The time period for reply, if any, is set in the attached communication.

Notice of the Office communication was sent electronically on above-indicated "Notification Date" to the following e-mail address(es):

ADIPDOC1@BIPC.com



UNITED STATES DEPARTMENT OF COMMERCE

U.S. Patent and Trademark Office

Address: COMMISSIONER FOR PATENTS
P.O. Box 1450
Alexandria, Virginia 22313-1450

APPLICATION NO./ CONTROL NO.	FILING DATE	FIRST NAMED INVENTOR / PATENT IN REEXAMINATION	ATTORNEY DOCKET NO.
14/764,087	28 July, 2015	ESBECH ET AL.	0079124-000111

BUCHANAN, INGERSOLL & ROONEY PC POST OFFICE BOX 1404 ALEXANDRIA, VA 22313-1404	EXAMINER	
	KEVIN PYO	
	ART UNIT	PAPER
	2878	20180403

DATE MAILED:

Please find below and/or attached an Office communication concerning this application or proceeding.

Commissioner for Patents

The IDS filed on 3/26/2018 has been considered by the examiner. The copy of PTO-1449 with the examiner's initials therein is attached to this communication.

/KEVIN PYO/
Primary Examiner, Art Unit 2878

Receipt date: 03/26/2018

Doc code: IDS
 Doc description: Information Disclosure Statement (IDS) Filed

PTO/SB/08a (01-10)
 Approved for use through 07/31/2012. OMB 0651-0031
 U.S. Patent and Trademark Office; U.S. DEPARTMENT OF COMMERCE
 Under the Paperwork Reduction Act of 1995, no persons are required to respond to a collection of information unless it contains a valid OMB control number.

INFORMATION DISCLOSURE STATEMENT BY APPLICANT (Not for submission under 37 CFR 1.99)	Application Number	14764087
	Filing Date	2015-07-28
	First Named Inventor	Bo ESBECH
	Art Unit	2878
	Examiner Name	PYO, KEVIN K
	Attorney Docket Number	0079124-000111

U.S.PATENTS							Remove
Examiner Initial*	Cite No	Patent Number	Kind Code ¹	Issue Date	Name of Patentee or Applicant of cited Document	Pages,Columns,Lines where Relevant Passages or Relevant Figures Appear	
	1						

If you wish to add additional U.S. Patent citation information please click the Add button.

U.S.PATENT APPLICATION PUBLICATIONS							Remove
Examiner Initial*	Cite No	Publication Number	Kind Code ¹	Publication Date	Name of Patentee or Applicant of cited Document	Pages,Columns,Lines where Relevant Passages or Relevant Figures Appear	
	1						

If you wish to add additional U.S. Published Application citation information please click the Add button.

FOREIGN PATENT DOCUMENTS								Remove
Examiner Initial*	Cite No	Foreign Document Number ³	Country Code ²ⁱ	Kind Code ⁴	Publication Date	Name of Patentee or Applicant of cited Document	Pages,Columns,Lines where Relevant Passages or Relevant Figures Appear	T ⁵
	1	2007117152	JP	A	2007-05-17	Pentax CORP		
	2	2009109263	JP	A	2009-05-21	Lasertec CORP		

If you wish to add additional Foreign Patent Document citation information please click the Add button.

NON-PATENT LITERATURE DOCUMENTS								Remove
---------------------------------	--	--	--	--	--	--	--	--------

ALL REFERENCES CONSIDERED EXCEPT WHERE LINED THROUGH. /KP/

Receipt date: 03/26/2018 INFORMATION DISCLOSURE STATEMENT BY APPLICANT (Not for submission under 37 CFR 1.99)	Application Number		14764087
	Filing Date		2015-07-28
	First Named Inventor	Bo ESBECH	
	Art Unit	2878	
	Examiner Name	PYO, KEVIN K	
	Attorney Docket Number	0079124-000111	

Examiner Initials*	Cite No	Include name of the author (in CAPITAL LETTERS), title of the article (when appropriate), title of the item (book, magazine, journal, serial, symposium, catalog, etc), date, pages(s), volume-issue number(s), publisher, city and/or country where published.	T ⁵
	1	Office Action (Notice of Reasons for Rejection) issued on January 9, 2018, by the Japanese Patent Office in Japanese Patent Application No. 2015-557430, and an English Translation of the Office Action. (8 pages)	×

If you wish to add additional non-patent literature document citation information please click the Add button

EXAMINER SIGNATURE

Examiner Signature	/KEVIN K PYO/	Date Considered	04/03/2018
--------------------	---------------	-----------------	------------

*EXAMINER: Initial if reference considered, whether or not citation is in conformance with MPEP 609. Draw line through a citation if not in conformance and not considered. Include copy of this form with next communication to applicant.

¹ See Kind Codes of USPTO Patent Documents at www.USPTO.GOV or MPEP 901.04. ² Enter office that issued the document, by the two-letter code (WIPO Standard ST.3). ³ For Japanese patent documents, the indication of the year of the reign of the Emperor must precede the serial number of the patent document. ⁴ Kind of document by the appropriate symbols as indicated on the document under WIPO Standard ST.16 if possible. ⁵ Applicant is to place a check mark here if English language translation is attached.

ALL REFERENCES CONSIDERED EXCEPT WHERE LINED THROUGH. /KP/



UNITED STATES PATENT AND TRADEMARK OFFICE

UNITED STATES DEPARTMENT OF COMMERCE
United States Patent and Trademark Office
Address: COMMISSIONER FOR PATENTS
P.O. Box 1450
Alexandria, Virginia 22313-1450
www.uspto.gov

APPLICATION NO.	ISSUE DATE	PATENT NO.	ATTORNEY DOCKET NO.	CONFIRMATION NO.
14/764,087	05/08/2018	9962244	0079124-000111	6247

21839 7590 04/18/2018
BUCHANAN, INGERSOLL & ROONEY PC
POST OFFICE BOX 1404
ALEXANDRIA, VA 22313-1404

ISSUE NOTIFICATION

The projected patent number and issue date are specified above.

Determination of Patent Term Adjustment under 35 U.S.C. 154 (b)
(application filed on or after May 29, 2000)

The Patent Term Adjustment is 223 day(s). Any patent to issue from the above-identified application will include an indication of the adjustment on the front page.

If a Continued Prosecution Application (CPA) was filed in the above-identified application, the filing date that determines Patent Term Adjustment is the filing date of the most recent CPA.

Applicant will be able to obtain more detailed information by accessing the Patent Application Information Retrieval (PAIR) WEB site (<http://pair.uspto.gov>).

Any questions regarding the Patent Term Extension or Adjustment determination should be directed to the Office of Patent Legal Administration at (571)-272-7702. Questions relating to issue and publication fee payments should be directed to the Application Assistance Unit (AAU) of the Office of Data Management (ODM) at (571)-272-4200.

APPLICANT(s) (Please see PAIR WEB site <http://pair.uspto.gov> for additional applicants):

Bo ESBECH, Gentofte, DENMARK;
3SHAPE A/S, Copenhagen k, DENMARK;
Christian Romer ROSBERG, Bronshoj, DENMARK;
Mike VAN DER POEL, Rodovre, DENMARK;
Rasmus KJAER, Kobenhavn K, DENMARK;
Michael VINTHER, Kobenhavn S, DENMARK;
Karl-Josef HOLLENBECK, Copenhagen O, DENMARK;

The United States represents the largest, most dynamic marketplace in the world and is an unparalleled location for business investment, innovation, and commercialization of new technologies. The USA offers tremendous resources and advantages for those who invest and manufacture goods here. Through SelectUSA, our nation works to encourage and facilitate business investment. To learn more about why the USA is the best country in the world to develop technology, manufacture products, and grow your business, visit SelectUSA.gov.