

Accelerometer Installation Guide

AIG

Table of Contents:

Section I:

Introduction

Section II:

Mounting Accessories
Installation Tools
Adhesives and Sealants

Section III:

Preferred Mounting Locations
Direct Mounting
Adhesive/Stud Mounting
Adhesive Mounting
NPT Adapter Mounting
Motor Fin Mount

Section IV:

Cabling
Signal Interference Sources
Sensor Wiring

Section I:

Introduction:

There are three mounting methods typically used for vibration monitoring applications; stud mounting, adhesive bonding and magnetic mounting. Stud mounting is the preferred method for permanent mounting applications. This method is accomplished by securing the sensor directly to the bearing housing using a mounting stud. This method allows the sensor to measure vibration according to the manufacturer's specifications. The mounting location for the accelerometer should be clean and paint free, also the mounting surface should be spot-faced to a surface smoothness of 32 micro-inches. The diameter of the spot-face should be about 10% larger than the sensor diameter. Any irregularities in the mounting surface preparation will translate into improper measurements or damage to the sensor may occur. STI prefers that a mounting pad be placed between the machine and the sensor to provide a smooth surface for the accelerometer to attach to.

Adhesive or glue mounting provides a secure attachment without extensive machining; however this method will reduce the operational frequency range since the adhesive will act like a shock absorber, this is also known as damping. The replacement or removal of the sensor is also more difficult than any other mounting method. The most important issue for using adhesives is surface cleanliness, without a clean surface the adhesive will not fully bond to the machine.

The magnetic mounting method is typically used for temporary measurements with a portable data collector or analyzer. This method is not recommended for permanent monitoring. The sensor may be inadvertently moved and the multiple surfaces and materials of the magnet may interfere with or increase high frequency signals.

As can be seen in the figure below, the mounting method has an effect on the operating frequency range of an accelerometer. By design, accelerometers have a natural resonance which is 3 to 5 times higher than the advertised high end frequency response. The frequency response range is limited so that a flat response is provided over the operating range. The advertised range is achievable only by stud mounting. Any other mounting method will adversely affect the natural resonance, and in turn the usable frequency response range.

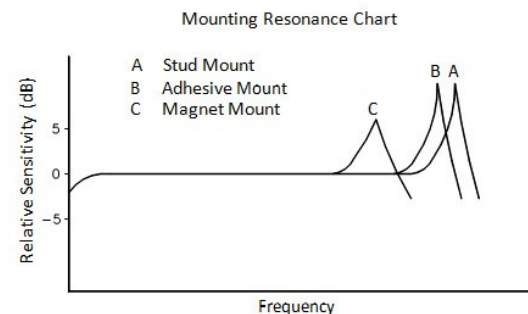

STI's preferred mounting method is the stud mount with mounting pad and epoxy.

Section II: Mounting Accessories:

Part Number	Description	Use
CMCP-200 Series CMCP200-01 CMCP200-02	Accelerometer Mounting Pads 1/4" x 1" Dia. 3/8" x 1" Dia.	Provides Ideal Mounting Surface. Use 1/4" pad for stud/adhesive mounting and 3/8" pad for adhesive mounting.
CMCP203 Series CMCP203-01 CMCP203-02 CMCP203-03 CMCP203-04	Pipe Thread Mounting Adapter 1/2" NPT 3/4" NPT 3/8" NPT 1/4" NPT	Makes use of existing NPT threaded holes to mount sensors. Adapters are finished with a lapped surface and a 1/4"-28 threaded hole.
CMCP205 Series CMCP205-01 CMCP205-02 CMCP205-03 CMCP205-04	Motor Fin Mounts 1.25" L x 0.50" W 2.00" L x 0.50" W 1.75" L x 0.25" W 1.00" L x 0.25" W	Allows for mounting sensors in between motor fins when a flat surface is not available. Tips are angled to ensure contact with machine casing.
CMCP230 Series CMCP230-01 CMCP230-02 CMCP230-03	1/4"-28 UNF Mounting Studs 1/2" in Length 3/4" in Length 3/8" in Length	Sold in packs of 10.



Installation Tools:

Part Number	Description	Use
CMCP270	Piloted End Mill	Used to mill a 1" flat surface and also provides a guide hole for tapping 1/4"-28 threads. Includes end mill, pilot, drill bit and Allen wrench
CMCP271	Piloted End Mill with Replaceable Cutting Tips	Same as CMCP270 but provides replaceable cutting tips. Cost effective when mounting a large quantity of sensors.



Adhesives and Sealants:

Part Number	Description	Use
CMCP206	Adhesive Filler	Used to fill voids when installing CMCP205 motor fin mounts. 2 Part Epoxy
CMCP207	Adhesive Dispenser	Used to dispense CMCP206 Adhesive Filler
CMCP208	Mixing Nozzle	Used to mix CMCP206 two part epoxy
CMCP210	Acrylic Adhesive Bypacs	2 Part Epoxy for easier mounting of 1 or 2 sensors
CMCP211	Depend 330 and Activator	2 Part Adhesive with spray activator. Good for over 10 installations
CMCP212	Silicone Dielectric	Helps ensure transmittal of higher frequencies
CMCP213	Silicone Sealant	Used to "flood" connectors to eliminate moisture build up inside of sensor connector



Section III: Preferred Mounting Locations:

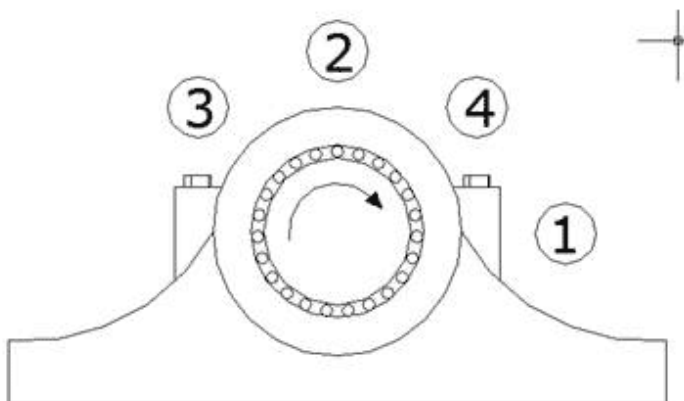

Preferred Mounting Locations

Direct Stud Mount:

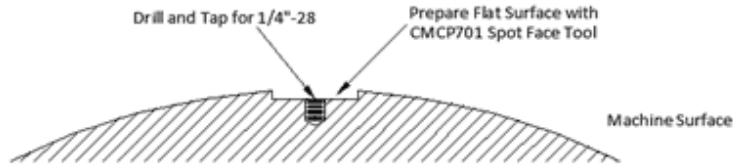

Sensor Installation - Stud Mount

Applicable Frequency Range: 0.32 - 10,000 Hz

1. Locate Sensor Location.
2. Machine Flat Area Using CMCP701 Kit.
3. Drill and Tap Location for 1/4"-28 UNF.
4. Remove All Debris and Clean.
5. Lightly Grease Contact Surface w/CMCP212 Silicone Grease.
6. Install CMCP230-01 1/4"-28 UNF x 1/2" Mounting Stud Into Tapped Hole.
7. Attach Sensor to Extruding Stud and Tighten to 30 in/lb.

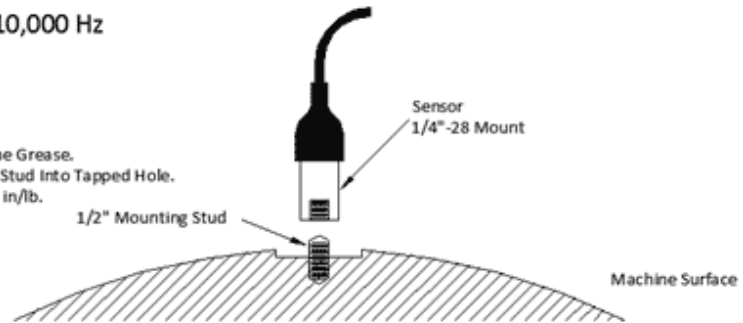

Mounting Pad Mount w/Adhesive: (Preferred)

CMCP200-0X Mounting Pad Installation - Stud/Adhesive Mount

Applicable Frequency Range: 6,000 - 10,000 Hz

1. Locate Sensor Location
2. Machine Flat Area
3. Using CMCP-701 Kit, Drill and Tap Location for 1/4"-28
4. Remove All Debris and Clean with ODC Free Cleaner
5. Install 1/4"-28 x 3/4" Mounting Stud into Tapped Hole
6. Apply Adhesive to Mounting Stud
7. Screw Mounting Pad onto Mounting Stud
8. Attach Sensor to Extruding Stud On Top of Mounting Pad

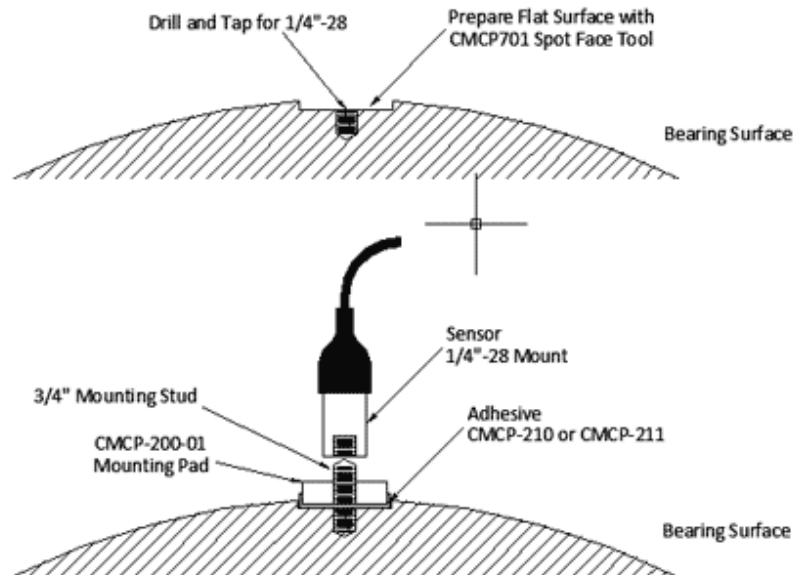

Mounting Pad Mount w/Adhesive: (Preferred)

CMCP200-0X Mounting Pad Installation - Stud/Adhesive Mount Applicable Frequency Range: 6,000 - 10,000 Hz

1. Locate Sensor Location
2. Machine Flat Area
3. Using CMCP-701 Kit, Drill and Tap Location for 1/4"-28
4. Remove All Debris and Clean with ODC Free Cleaner
5. Install 1/4"-28 x 3/4" Mounting Stud into Tapped Hole
6. Apply Adhesive to Mounting Pad
7. Screw Mounting Pad onto Mounting Stud
8. Attach Sensor to Extruding Stud On Top of Mounting Pad

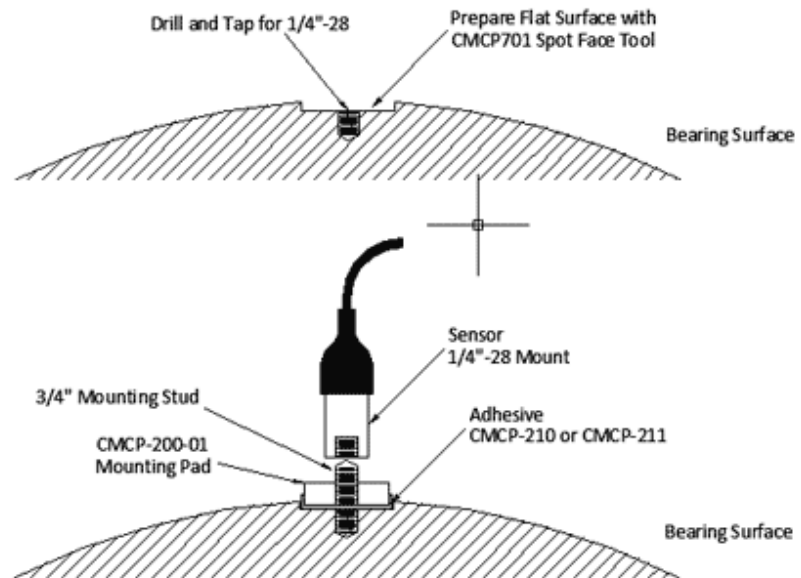

Mounting Pad with Adhesive Mount:

CMCP200-0X Mounting Pad Installation - Adhesive Mount Applicable Frequency Range: 2,500-4,000 Hz

1. Locate Sensor Location (See Preferred Location Drawing)
2. Machine Flat Area
3. Remove All Debris and Clean with ODC Free Cleaner
4. Secure Mounting Pad with Adhesive

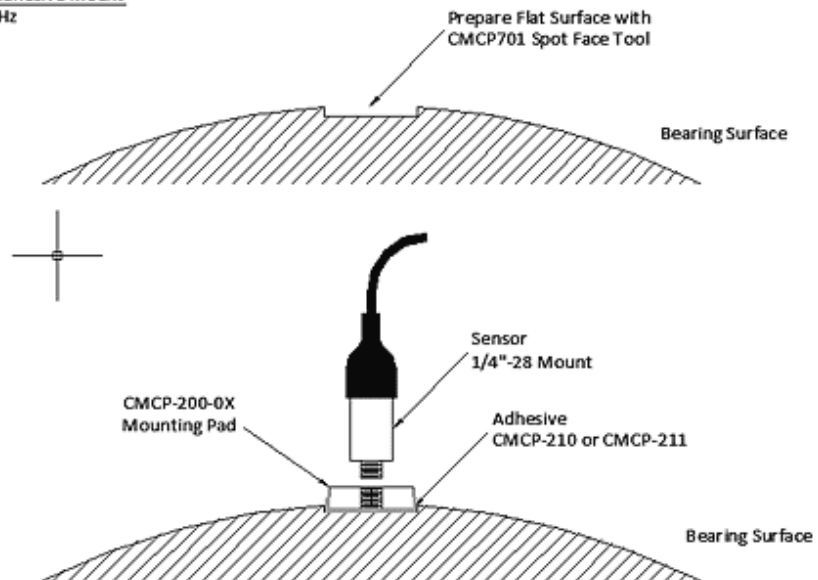

Explore Litigation Insights

Docket Alarm provides insights to develop a more informed litigation strategy and the peace of mind of knowing you're on top of things.

Real-Time Litigation Alerts



Keep your litigation team up-to-date with **real-time alerts** and advanced team management tools built for the enterprise, all while greatly reducing PACER spend.

Our comprehensive service means we can handle Federal, State, and Administrative courts across the country.

Advanced Docket Research



With over 230 million records, Docket Alarm's cloud-native docket research platform finds what other services can't. Coverage includes Federal, State, plus PTAB, TTAB, ITC and NLRB decisions, all in one place.

Identify arguments that have been successful in the past with full text, pinpoint searching. Link to case law cited within any court document via Fastcase.

Analytics At Your Fingertips



Learn what happened the last time a particular judge, opposing counsel or company faced cases similar to yours.

Advanced out-of-the-box PTAB and TTAB analytics are always at your fingertips.

API

Docket Alarm offers a powerful API (application programming interface) to developers that want to integrate case filings into their apps.

LAW FIRMS

Build custom dashboards for your attorneys and clients with live data direct from the court.

Automate many repetitive legal tasks like conflict checks, document management, and marketing.

FINANCIAL INSTITUTIONS

Litigation and bankruptcy checks for companies and debtors.

E-DISCOVERY AND LEGAL VENDORS

Sync your system to PACER to automate legal marketing.