

Piezoelectric Accelerometers and Vibration Preamplifiers

Theory and Application Handbook

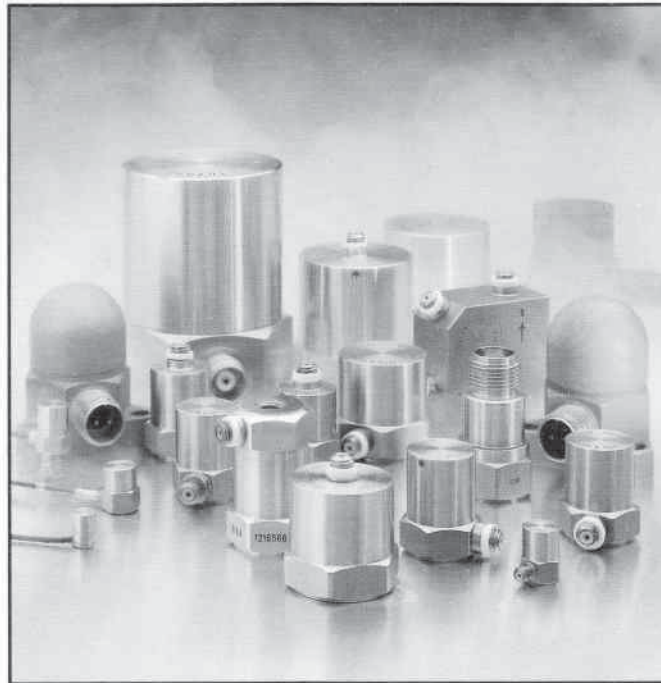

Brüel & Kjær 

**PIEZOELECTRIC ACCELEROMETER
AND
VIBRATION PREAMPLIFIER
HANDBOOK**

by

Mark Serridge, BSc

and

Torben R. Licht, MSc

Revision November 1987

Printed in Denmark: K. Larsen & Søn A/S - DK-2600 Glostrup

CONTENTS

1. VIBRATION MEASUREMENT	1
1.1. INTRODUCTION	1
1.2. WHY MEASURE VIBRATION?	1
1.3. WHAT IS VIBRATION?	5
1.4. VIBRATION PARAMETERS	6
1.5. THE QUANTIFICATION OF VIBRATION LEVELS	7
Linear amplitude and frequency scales	9
Logarithmic amplitude and frequency scales	9
1.6. ANALYSIS OF VIBRATION MEASUREMENTS	11
2. THE PIEZOELECTRIC ACCELEROMETER	12
2.1. INTRODUCTION	12
2.2. OPERATION OF AN ACCELEROMETER	13
Analytical treatment of accelerometer operation	14
2.3. FREQUENCY RANGE	18
Upper frequency limit	19
Lower frequency limit	20
2.4. PIEZOELECTRIC MATERIALS	20
2.5. PRACTICAL ACCELEROMETER DESIGNS	22
Line-drive accelerometers	24
Other designs	25
2.6. ACCELEROMETER SENSITIVITY	25
Charge and voltage sensitivity	26
Uni-Gain [®] sensitivity	28
Linearity and dynamic range	28
Transverse sensitivity	29
2.7. PHASE RESPONSE	30
2.8. TRANSIENT RESPONSE	33
Leakage effects	33
Ringing	35
Zero shift	37

3. VIBRATION PREAMPLIFIERS	38
3.1. PREAMPLIFIER DESIGN AND OPERATION	39
3.2. CHARGE AMPLIFIERS	39
Charge sensitivity	40
Lower Limiting Frequency	44
Capacitive loading of input by accelerometer cables	48
Charge attenuation	49
Noise in charge amplifiers	50
3.3. VOLTAGE PREAMPLIFIERS	54
Voltage sensitivity	55
Lower Limiting Frequency	56
Noise in voltage preamplifiers	57
3.4. PREAMPLIFIER OUTPUT CABLES	57
3.5. LINE-DRIVE SYSTEMS	58
Brüel & Kjær line-drive accelerometer and line-drive supply	61
Brüel & Kjær line-drive amplifier and line-drive supply	61
3.6. COMPARISON OF THE SENSITIVITY OF DIFFERENT VIBRATION PREAMPLIFIER SYSTEMS TO EXTERNAL NOISE SOURCES	61
Grounded accelerometer and charge preamplifier	64
Grounded accelerometer with charge preamplifier ("floating" input)	65
Brüel & Kjær line-drive amplifier and power supply (grounded input)	66
Brüel & Kjær line-drive amplifier and power supply ("floating" input)	68
Line-drive system based on constant current power supply	70
Balanced accelerometer and differential charge amplifier	69
Insulated mounting of the accelerometer	71
3.7. SPECIAL PREAMPLIFIER FEATURES	71
Integration Networks	72
Filters	76
Overload Indicator	78
Reference Oscillator	78
Power Supplies	78
 4. ACCELEROMETER PERFORMANCE IN PRACTICE	 79
4.1. INTRODUCTION	79
4.2. ENVIRONMENTAL EFFECTS	80
Temperature range	80
Temperature transients	82

Acoustic sensitivity	84
Base strains	85
Humidity	85
Magnetic sensitivity	86
Radiation	86
4.3. MASS LOADING EFFECTS OF ACCELEROMETERS	86
4.4. MOUNTING THE ACCELEROMETER	88
Vibration test surface finish requirements	89
Mounting location	89
Determination of the frequency response of accelerometers using different mounting techniques	90
Stud mounting	90
Wax mounting	93
Magnetic mounting	95
Self-adhesive mounting discs	97
Adhesives	98
Probes	102
4.5. MECHANICAL FILTERS	105
Description	105
Operation	106
4.6. ACCELEROMETER CABLES	107
4.7. GROUNDING PRECAUTIONS	109
5. ACCELEROMETER CALIBRATION AND TESTING	111
5.1. INTRODUCTION	111
Why calibrate an accelerometer?	113
5.2. THE HIERARCHY OF CALIBRATION STANDARDS	114
The general hierarchy	114
The hierarchy at B & K	115
The accuracy of calibration techniques	118
5.3. CALIBRATION METHODS	119
Laser Interferometry	119
Other absolute methods	121
Comparison calibration by the “back-to-back” method	121
FFT-based back-to-back calibration	123
The use of calibrated vibration exciters for sensitivity checking	124
5.4. MEASUREMENT OF OTHER ACCELEROMETER PARAMETERS ..	125
Transverse sensitivity	125
Frequency response	126
Undamped natural frequency	128
Capacitance	129

5.5. DETERMINATION OF THE EFFECTS OF THE ENVIRONMENT ON THE ACCELEROMETER SPECIFICATIONS	129
Temperature transient sensitivity	129
Temperature sensitivity	129
Base strain sensitivity	130
Acoustic sensitivity	130
Magnetic sensitivity	131
Temperature limits	131
Shock limits	132
5.6. FACTORY TESTING OF ACCELEROMETER CABLES	132
5.7. CALIBRATION EQUIPMENT	133
Calibration System Type 9559	133
Individual calibration equipment	133
5.8. STANDARDS RELATING TO THE CALIBRATION OF ACCELEROMETERS	134
6. APPENDICES	137
APPENDIX A. Conversion charts	138
APPENDIX B. Vibration nomogram	141
APPENDIX C. Vibration standards	142
APPENDIX D. Brüel & Kjær Vibration Literature	142
APPENDIX E. Summary of Brüel & Kjær Preamplifiers	144
APPENDIX F. Summary of Brüel & Kjær instruments with built-in preamplifiers	146
APPENDIX G. Brüel & Kjær accelerometer frequency and dynamic range charts	148
APPENDIX H. Summary of Brüel & Kjær accelerometers	150

SYMBOL NOTATION

General Quantities

- t = Time
- f = Frequency
- ω = Angular frequency
- j = $\sqrt{-1}$
- e = Base to the Natural Logarithm

General Dynamics

- x = Displacement
- v = Velocity
- a = Acceleration
- F = Force
- T = Period
- τ = Time constant

Accelerometer Dynamics

- m_s = Seismic mass
- m_b = Mass of base
- x_s = Displacement of seismic mass
- x_b = Displacement of base
- F_e = Excitation force
- ω_n = Natural resonance frequency (rads/sec)
- ω_m = Mounted resonance frequency (rads/sec)
- f_m = Mounted resonance frequency (Hz)
- A = Amplification factor
- Z_s = Mechanical Impedance of structure
- Z_a = Mechanical Impedance of accelerometer

General Electrical Quantities

- I = Current
- V = Voltage
- Q = Charge
- C = Capacitance
- R = Resistance
- Z = Impedance

SYMBOL NOTATION

Accelerometer Electrical Quantities

V_a	= Open circuit accelerometer voltage
Q_a	= Charge generated by piezoelectric elements
C_a	= Capacitance of accelerometer
R_a	= Resistance of accelerometer
S_{qa}	= Charge sensitivity of accelerometer
S_{va}	= Voltage sensitivity of accelerometer (loaded)
S_{vao}	= Voltage sensitivity of accelerometer (open circuit)
C_h	= Capacitance to the housing of a balanced accelerometer from the output pins

Cable Electrical Quantities

C_c	= Capacitance of cable
R_c	= Series resistance of cable
R_b	= Resistance between centre conductor and screen
C_s	= Capacitance between screen and inner conductors in balanced accelerometer cable
C_d	= Capacitance of dielectric in balanced accelerometer cable
q_n	= Triboelectric charge noise

Preamplifier Electrical Quantities

R_p	= Preamplifier input resistance
C_p	= Preamplifier input capacitance
C_f	= Feedback capacitance
R_f	= Feedback resistance
A	= Gain of operational amplifier
V_i	= Preamplifier input voltage
V_o	= Preamplifier output voltage
Z_f	= Feedback impedance
Z_t	= Total impedance of accelerometer, cable and preamplifier input
I_i	= Current from C_f
I_c	= Current through feedback capacitor
V_c	= Voltage across feedback capacitor
C_t	= Total capacitance of accelerometer, cable and preamplifier input
R_t	= Total resistance of accelerometer, cable and preamplifier input
R_{float}	= Resistance of "floating" stage of preamplifier
$CMRR$	= Common Mode Rejection Ratio of "floating" operational amplifier
e_n	= Noise voltage
i_n	= Noise current
R_o	= Output resistance of line-drive amplifier

1. VIBRATION MEASUREMENT

1.1. INTRODUCTION

Recent years have seen the rise of vibration problems associated with structures which are more delicate and intricate, and machines which are faster and more complex. The problems have been coupled with demands for lower running costs and increased efficiency. Concern has also arisen about the effects of noise and vibration on people and on the working lifetime of manufactured items. Consequently, there has been a requirement for a greater understanding of the causes of vibration and the dynamic response of structures to vibratory forces. To gain such an understanding an accurate, reliable and versatile vibration transducer is required. In addition, advanced measurement and analysis equipment is often used. However, both the versatility and capability of such equipment would be wasted without an accurate vibration signal from a reliable vibration transducer.

The piezoelectric accelerometer is the optimum choice of vibration transducer. The extensive range of high performance measuring equipment now available can fully utilize the very wide frequency range and dynamic range offered by this type of vibration transducer.

This handbook is intended primarily as a practical guide to making accurate vibration measurements with Brüel & Kjær piezoelectric accelerometers.

1.2. WHY MEASURE VIBRATION?

Vibration is measured for many different reasons. In general all uncontrolled vibration is an undesirable phenomenon which gives rise to noise, causes mechanical stress and is a possible cause of structural failure. Four broad areas of vibration measurement can be defined:

- 1. Vibration Testing.** As part of a general environmental test program or as a part of engineering design, vibration testing performs the vital role of finding out how well a component can endure the vibration environments which it is likely to encounter in a real-life situation.

During a vibration test, a structure (an aircraft component for example) is subjected to high vibration levels with a vibration exciter. The vibration level is held constant in defined frequency regions and the frequency is swept. This is achieved with a vibration exciter controller and a feedback accelerometer which provides data concerning the acceleration to which the structure is subjected. With the addition of a second accelerometer attached to the structure, frequency response information is obtained.

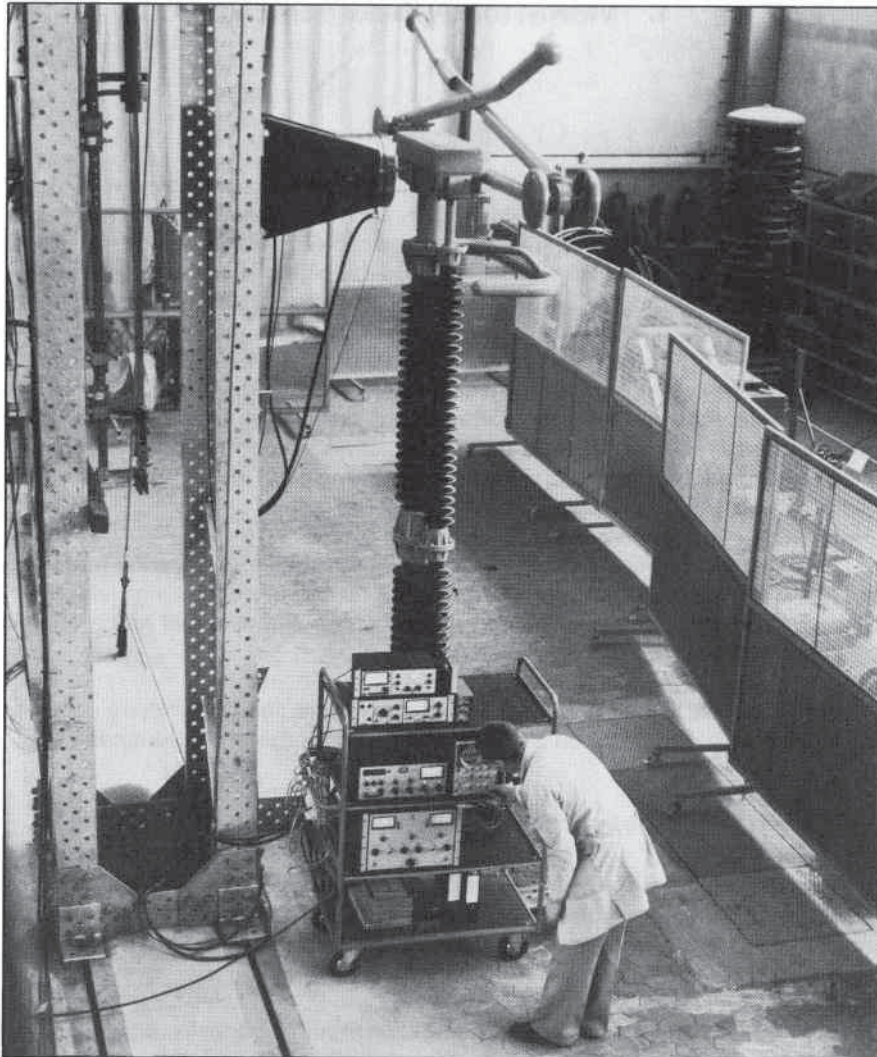

Fig. 1.1. Vibration testing of an insulator used in the construction of a high voltage electricity pylon

2. Machine Health Monitoring and Fault Diagnosis. In its simplest form an overall measurement of vibration level on a machine is used to give a warning of impending problems. However, more information can be obtained by frequency analysis. This technique involves measuring the characteristic frequency spectrum of the vibration of a machine in good condition and monitoring any changes of the spectral components using vibration measurements over a period of time. Such changes are normally indications of impending problems. Fault diagnosis can also be performed using vibration measurements.

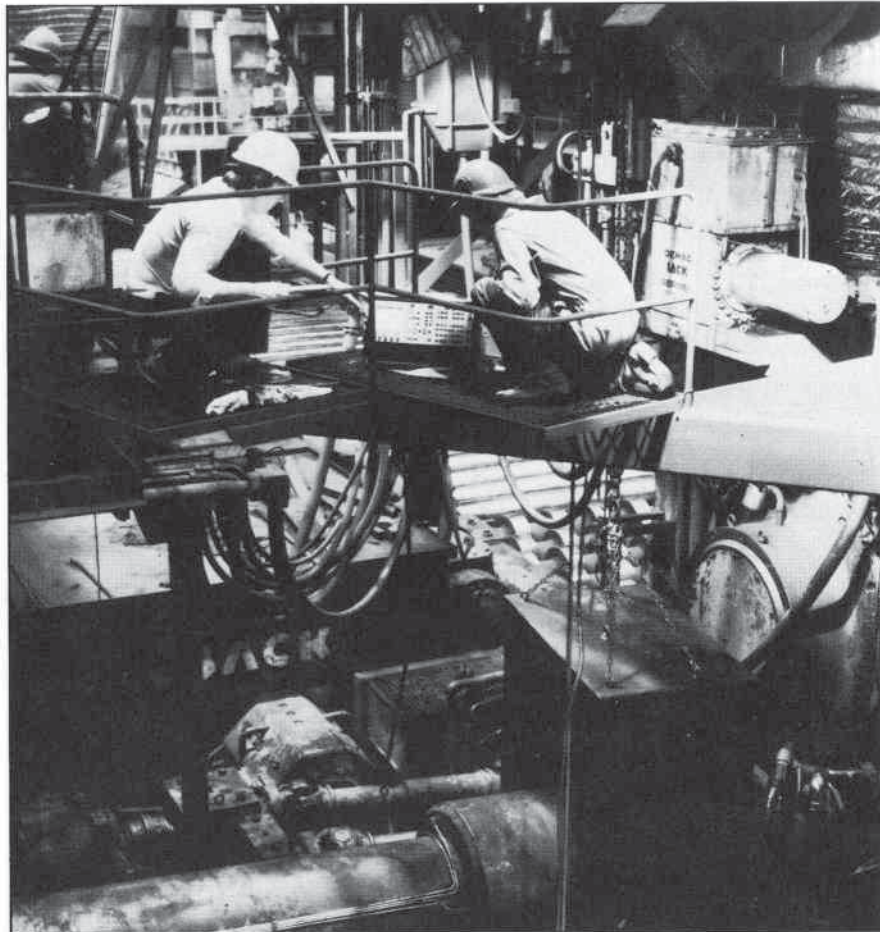

Fig. 1.2. Vibration measurements are used in a machine-health monitoring and fault diagnosis program

In industry vibration measurements also form the basis for correcting shaft unbalance in rotating machines. Unbalance is a cause of high vibration levels which often lead to fatigue and bearing failures.

- 3. Structural Analysis.** This is a powerful experimental method for determining the dynamic behaviour of a structure using vibration measurements. Using a force transducer and an accelerometer, the excitation signal and vibration response of a structure are measured simultaneously using a dual channel analyzer. High speed computation, performed within the analyzer and often in conjunction with a desk-top computer, provides essential information for the design verification and modification of structures varying in size from small turbine blades to large bridges.



Fig. 1.3. The structural analysis of a train carriage using vibration measurements

- 4. Human Vibration Measurement.** This area concerns the measurement of the vibration transmitted to human beings. These vibrations can, for example, originate from passenger vehicles and hand-held power tools. The measured vibration levels are then related to human comfort and health criteria by International Standards.



Fig. 1.4. Measuring the vibration levels transmitted from the handle of a chain saw using an accelerometer and a vibration meter

1.3. WHAT IS VIBRATION?

Vibration is a dynamic phenomenon observed as a to-and-fro motion about an equilibrium position. Vibration is caused by the transfer or storage of energy within structures, resulting from the action of one or more forces. Vibration is often a by-product of an otherwise useful operation and is very difficult to avoid.

Vibrations can be observed in the *time domain*, i.e. the change in the amplitude of the vibration with time ("time history"). Vibration time histories can fall into one of several classes as defined by their mathematical form or by the statistical properties of the motions they contain. Vibrations can also be looked at in the *frequency domain* where the vibration is described by its frequency spectrum. The two domains are related mathematically via the *Fourier Transform*. Consult the Brüel & Kjær book "Frequency Analysis" which deals with this topic.

Unlike other vibration transducers, piezoelectric accelerometers are used to measure *all* types of vibrations regardless of the nature of the vibration in the time domain or the frequency domain, *as long as the accelerometer has the correct frequency and dynamic ranges*. Because of the wide frequency and dynamic ranges of piezoelectric accelerometers it is always possible to find a particular type for any vibration measurement. It is only the analysis techniques which must change according to the type of vibration.

1.4. VIBRATION PARAMETERS

The piezoelectric accelerometer measures acceleration and this signal can be electronically integrated once to provide the velocity signal and a second time to provide the displacement signal. This is an attractive feature of piezoelectric accelerometers.

Fig. 1.5 shows the effect of integrating the acceleration of an electric drill. The vibration is displayed in the frequency domain. The integrator acts as a low-pass filter and attenuates the high frequency components present before the integration. Using an integration network effectively "throws away" information about the vibration. Obviously this is only acceptable if the lost information is not required for the purpose of the measurement.

Acceleration should always be used if there is no reason for an integration. For example, an obvious reason for measuring velocity is to obtain the actual vibration velocity magnitude. It is also often desirable to minimize the dynamic range requirements of the measuring instruments in the vibration measurement set-up and hence increase the signal-to-noise ratio of the measurement. This is achieved by using the parameter which gives the flattest frequency spectrum (see Fig.1.5(b)). Only frequency analysis can reveal the frequency composition of a vibration signal. For broad-band (wide frequency content) measurements on rotating machines the velocity parameter is found to be the best in 70% of all cases, acceleration in 30% and displacement is hardly ever used. Displacement parameters are sometimes used for measurements of low frequency and large displacement vibrations often encountered on structures such as ships, buildings and bridges.

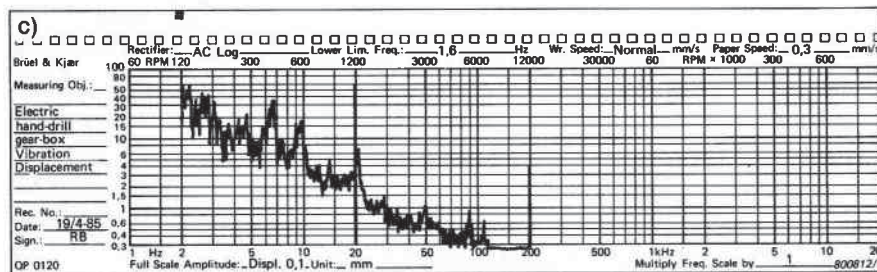
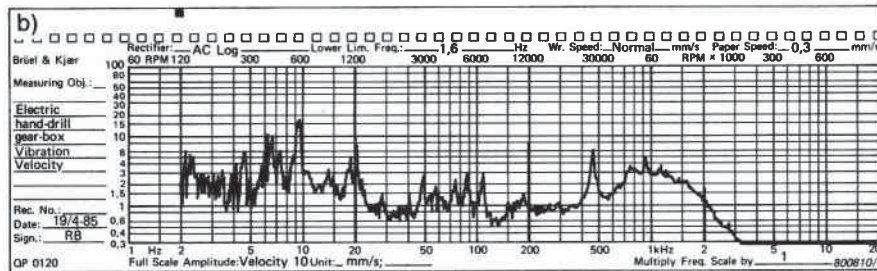
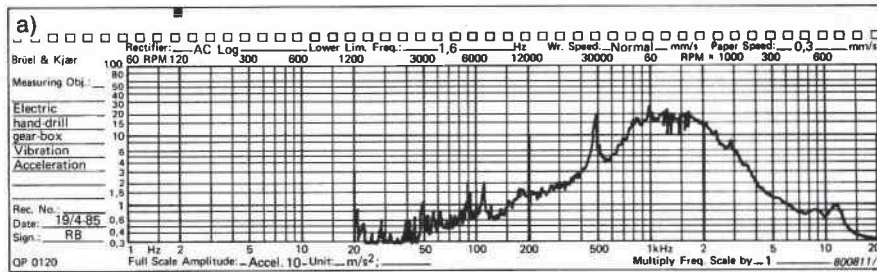

Fig. 1.5. Frequency analysis of the vibration of an electric drill using the three different measurement parameters-acceleration, velocity and displacement

When complex signals such as shocks and impulses are measured integration networks should *not* be used because they introduce phase errors resulting in serious amplitude measurement errors.

1.5. THE QUANTIFICATION OF VIBRATION LEVELS

There are several ways of quantifying the vibration amplitude of a signal in the time domain. The actual measurement units (for example, in/s^2 , m/s^2 , g etc) may differ although the descriptors described in this section are widely used.

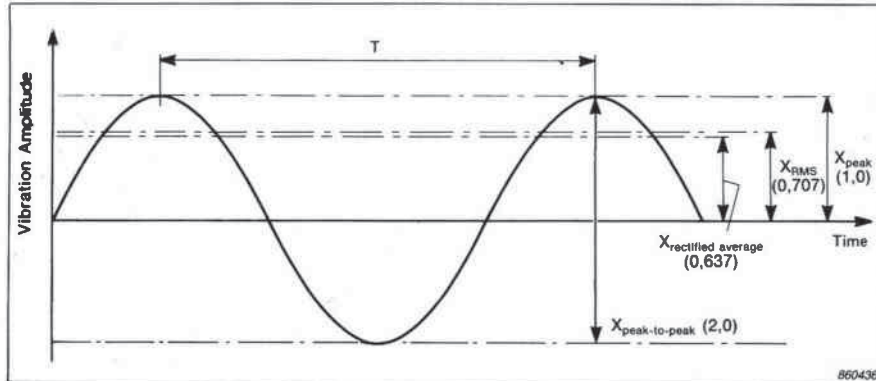

Fig. 1.6. Simple harmonic vibration. The amplitude referred to can be displacement, velocity or acceleration

Fig. 1.6 shows the simplest form of vibration time history. It is represented by a particle oscillating about a reference position where exactly equal conditions of motion are encountered at fixed time intervals. This time interval is called the period, T , of the vibration. The vibration amplitude varies sinusoidally with time.

It can be shown that the shape and period of the vibration remain the same when displacement, velocity or acceleration amplitude is chosen to represent the motion. Only the relative phases are different.

The amplitude of the vibration signal shown in Fig. 1.6 can be described by using the following descriptors.

1. **RMS (Root Mean Square) Level:** Provides the most useful description of vibration levels. The square root of the integrated time-averaged squared function is related to the vibration energy and hence the vibration's damage potential. The RMS value of a sine wave is $1/\sqrt{2}$ times the value of the peak level.
2. **Peak Level:** Defines the maximum level which is measured and is useful in the measurement of short duration shocks. However, no account is taken of the time history of the vibration.
3. **Peak-to-peak:** Although of some use in describing vibration displacements, this descriptor is rarely used.
4. **Average Level:** Takes the time history of the vibration into account but there is no useful relationship between the average level and any physical quantity. In Fig. 1.6 the average value of the *rectified* sine wave is referred to.

5. **Crest Factor:** Defines the ratio of the peak value of a signal to the RMS value. From the definition of RMS above, the crest factor for the sine wave in Fig. 1.6 is $\sqrt{2}$. As the vibration becomes more impulsive, or more random, the crest factor increases. This simple relationship is easily calculated with a simple vibration meter equipped with RMS and peak facilities. When making wide-band measurements on a machine's bearing housing, an increase in a single vibration component caused by a faulty bearing may be undetectable in the RMS measurement, but might be indicated by an increase in the crest factor. Hence by monitoring the growth of the crest factor, it is possible to predict a breakdown or element fault.

Another example of the utility of crest factors can be found in structural testing techniques. The crest factor of the input signal to the structure can reveal important information about the excitation. If the crest factor is very high, as can be the case with hammer excitation, the structure may be driven into non-linear dynamic behaviour. A high crest factor also indicates that the input may not contain sufficient energy to obtain a good signal-to-noise ratio. On the other hand, a high crest factor is an indication that the input has a wide frequency range.

1.5.1. Linear Amplitude and Frequency Scales

Linear amplitude and frequency scales are used in vibration measurements when a high resolution is needed. A linear frequency scale helps to separate closely spaced frequency components. The linear frequency scale gives the further advantage that equally spaced harmonic components of a vibration signal are easily recognized.

1.5.2. Logarithmic Amplitude and Frequency Scales

Piezoelectric accelerometers are capable of accurate vibration measurements over extremely wide dynamic and frequency ranges. Therefore, to obtain convenient interpretation of results the following are often required:

1. An amplitude scale which can accommodate vibration amplitudes from the lowest detectable amplitudes up to shock amplitudes, and which can also simplify the comparison of vibration amplitudes.
2. A frequency scale with the same percentage resolution over the whole width of the recording chart.

The two objectives can be achieved using the following:

1. **A decibel scale.** Although more commonly associated with acoustic measurements the decibel (dB) is equally useful in vibration measurements. It is defined as the ratio of one amplitude to another and it is expressed in a logarithmic form. For vibration amplitude ratios the following relationship exists:

$$\begin{aligned} N(\text{dB}) &= 10 \log_{10} \left(\frac{a^2}{a_{\text{ref}}^2} \right) \\ &= 20 \log_{10} \left(\frac{a}{a_{\text{ref}}} \right) \end{aligned}$$

Where

- N = number of decibels
 a = measured vibration amplitude
 a_{ref} = reference amplitude

According to ISO 1683 the reference amplitudes are as follows:

$$\text{Acceleration} = 10^{-6} \text{ms}^{-2}$$

$$\text{Velocity} = 10^{-9} \text{ms}^{-1}$$

$$\text{Displacement} = 10^{-12} \text{m}$$

For a sine wave of angular frequency $\omega = 1000$ radians per second (at approximately 159 Hz) these amplitudes are numerically equivalent. The reference amplitudes must be referred to when vibration levels are stated in dBs (e.g. "The vibration level was measured at 110 dB referred to 10^{-6}ms^{-2} "). However, when vibration amplitudes are compared, the difference in the decibels can be used provided that they are referred to the same reference. For example, it is correct to say that one level is 20 dB above another without any further reference.

2. **A logarithmic frequency scale.** Frequency is sometimes plotted on a logarithmic scale. This type of scale has the effect of expanding the lower frequency ranges and compressing the higher frequency ranges. The result is equal relative resolution over the frequency axis (on a screen or on paper), and the size of the scale is kept to reasonable proportions. Thus a logarithmic frequency scale is used to cover a wide frequency scale.

1.6. ANALYSIS OF VIBRATION MEASUREMENTS

The amount of information that can be obtained from traditional time domain analysis is limited although modern time domain analysis techniques are becoming more powerful. However, with the addition of frequency analysis equipment, such as analogue and digital frequency analyzers, very useful additional information is obtained. No in-depth coverage of instruments of this nature is given in this handbook. The Brüel & Kjær books "Mechanical Vibration and Shock Measurements" and "Frequency Analysis" should be referred to for a solid theoretical background in frequency analysis, while the main and short catalogues should be consulted for details of the range of instruments available from Brüel & Kjær.

The complexity of the measuring instrumentation and the analysis of results may vary widely. But in every case the vibration transducer is the most critical link in the measurement chain, for without an accurate vibration signal the results of further analysis will not be reliable.

The most reliable, versatile and accurate vibration transducer is the piezoelectric accelerometer.

2. THE PIEZOELECTRIC ACCELEROMETER

2.1. INTRODUCTION

The aim of this chapter is to give a basic, and often theoretical insight into the operation and the characteristics of the piezoelectric accelerometer. Due to the nature of its operation the performance of the vibration preamplifier will need to be included to a small extent. However for a complete description of the operation and characteristics of preamplifiers, Chapter 3 "Vibration Preamplifiers" should be consulted. A summary of the complete Brüel & Kjær range of accelerometers can be found in Appendix H.

The piezoelectric accelerometer is widely accepted as the best available transducer for the absolute measurement of vibration. This is a direct result of these properties:

1. Usable over very wide frequency ranges.
2. Excellent linearity over a very wide dynamic range.
3. Acceleration signal can be electronically integrated to provide velocity and displacement data.
4. Vibration measurements are possible in a wide range of environmental conditions while still maintaining excellent accuracy.
5. Self-generating so no external power supply is required.
6. No moving parts hence extremely durable.
7. Extremely compact plus a high sensitivity to mass ratio.

In order to appreciate these advantages it is worth examining the characteristics of a few other types of vibration transducer and vibration measurement devices.

1. **Proximity probe.** A device measuring only relative vibration displacement. It has a response to static displacements and also a low electrical impedance output. However, the device is not self-generating and the high frequency performance is poor. In addition the vibrating surface must be electrically conductive.

2. **Capacitive probe.** A small, non-contact, vibration displacement transducer with a high sensitivity and a wide frequency range. The disadvantages are, however, that the vibrating surface must be electrically conductive, the probe's dynamic range is very limited and it is difficult to calibrate.
3. **Position potentiometer.** A low cost, low impedance device capable of measuring static displacements. However, the dynamic and frequency ranges are limited and the device only has a short working lifetime and low resolution.
4. **Piezoresistive transducer.** A vibration acceleration transducer which is capable of measuring static accelerations. The measuring frequency and dynamic ranges can be wide. The limited shock handling capacity means that this type of transducer is easily damaged. Viscous damping is often used to protect the transducer against shocks. However, this leads to a reduction in the operating temperature range and alters the phase characteristics.
5. **Moving coil.** A self-generating low impedance vibration velocity transducer. It is severely limited in its frequency range and dynamic range, is susceptible to magnetic fields and is affected by its orientation.

2.2. OPERATION OF AN ACCELEROMETER

Fig. 2.1 illustrates a simplified model of a Brüel & Kjær Delta Shear[®] accelerometer showing only the mechanical parts. The active elements of the accelerometer are the piezoelectric elements. These act as springs connecting the

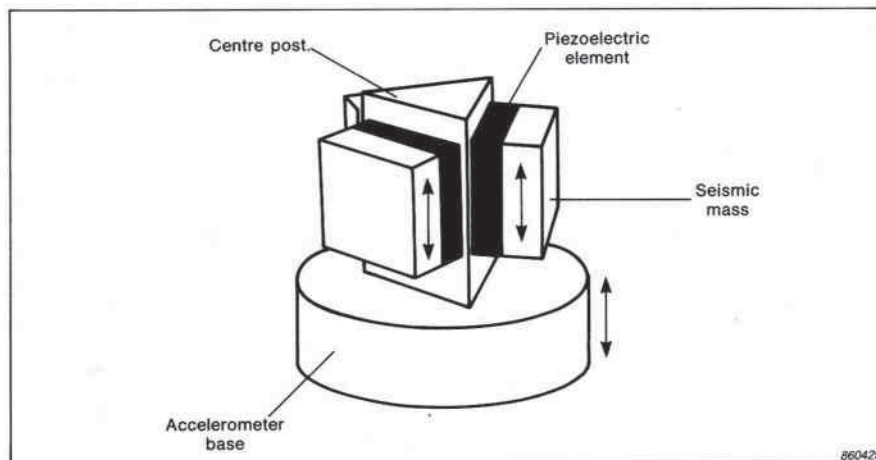

Fig. 2.1. Schematic of a Brüel & Kjær Delta Shear[®] piezoelectric accelerometer

base of the accelerometer to the seismic masses via the rigid triangular centre post. When the accelerometer is vibrated a force, equal to the product of the acceleration of a seismic mass and its mass, acts on each piezoelectric element. The piezoelectric elements produce a charge proportional to the applied force. The seismic masses are constant and consequently the elements produce a charge which is proportional to the acceleration of the seismic masses. As the seismic masses accelerate with the same magnitude and phase as the accelerometer base over a wide frequency range, the output of the accelerometer is proportional to the acceleration of the base and hence to the acceleration of the surface onto which the accelerometer is mounted.

The above model can be simplified as shown in Fig. 2.2.

2.2.1. Analytical Treatment of Accelerometer Operation

Fig. 2.2 shows a simplified model of the accelerometer described in the last section and referenced to an inertial system. The two masses are unsupported and connected by an ideal spring. Damping is neglected in this model because Brüel & Kjær accelerometers have very low damping factors.

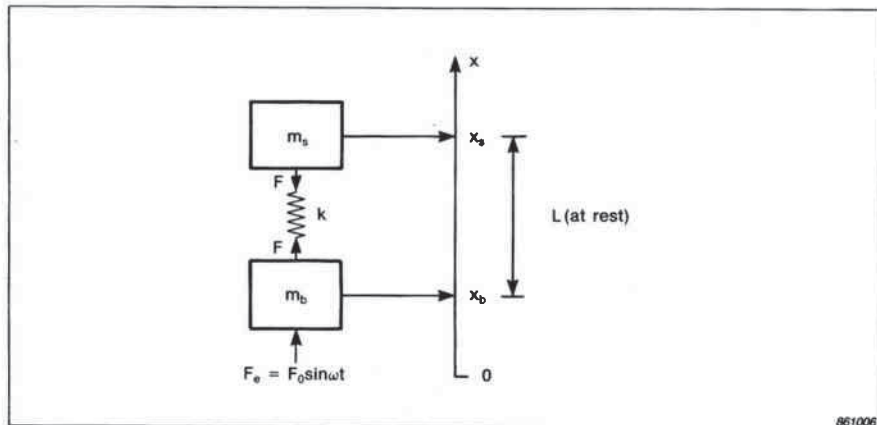

Fig. 2.2. Simplified model of an accelerometer

- m_s = total seismic mass
- m_b = mass of the accelerometer base
- x_s = displacement of the seismic mass
- x_b = displacement of the accelerometer base

- L = distance between the seismic mass and the base when the accelerometer is at rest in the inertial system
 k = equivalent stiffness of the piezoelectric elements
 F_e = harmonic excitation force
 F_0 = amplitude of excitation force
 ω = excitation frequency (rad/s) = $2\pi f$
 ω_n = natural resonance frequency of the accelerometer (rad/s)
 ω_m = mounted resonance frequency of the accelerometer (rad/s)
 f_m = mounted resonance frequency of the accelerometer (Hz)
 f = excitation frequency (Hz)

The following expressions describe the forces present in the model

$$F = k(x_s - x_b - L) \text{ (spring force)}$$

$$m_b \ddot{x}_b = F + F_e \text{ (force on base)}$$

$$m_s \ddot{x}_s = -F \text{ (force on seismic masses)}$$

The equation of motion for the model can be found

$$\ddot{x}_s - \ddot{x}_b = -\frac{F}{m_s} - \frac{F + F_e}{m_b} = -\frac{k}{\mu} (x_s - x_b - L) - \frac{F_e}{m_b} \quad (1)$$

or

$$\mu \ddot{r} = -kr - \frac{\mu}{m_b} F_0 \sin \omega t$$

Where

$$\frac{1}{\mu} = \frac{1}{m_s} + \frac{1}{m_b}$$

or

$$\mu = \frac{m_s m_b}{m_s + m_b}$$

μ is often referred to as the "reduced mass" and r is the relative displacement of the seismic mass to the base

$$r = x_s - x_b - L$$

When the accelerometer is in a free hanging position and is not being excited by external forces ($F_e = 0$) the equation of motion for its *free vibration* reduces to

$$\mu \ddot{r} = -kr$$

This simple differential equation can be solved by assuming that the displacement of m_s relative to m_b varies harmonically with an amplitude R . In other words

$$r = R \sin \omega t$$

$$-\mu R \omega^2 \sin \omega t = -kR \sin \omega t$$

and therefore the *resonance frequency* of the accelerometer, ω_n , can be written directly as

$$\omega_n^2 = \frac{k}{\mu}$$

The implications of this result can be seen by rewriting this equation as follows

$$\omega_n^2 = k \left(\frac{1}{m_s} + \frac{1}{m_b} \right) \quad (2)$$

If the accelerometer is now mounted with perfect rigidity onto a structure which is heavier than the total weight of the accelerometer then m_b becomes much larger than m_s . The resonance frequency of the accelerometer becomes lower. Taken to the limit, if the accelerometer is mounted on an *infinitely* heavy structure ($m_b \rightarrow \infty$) then the last equation reduces to

$$\omega_m^2 = \frac{k}{m_s} \quad (3)$$

This is the natural frequency of the seismic mass-spring system and is defined as the *mounted resonance frequency*, ω_m , of the accelerometer. The *mounted resonance frequency* is a *property* of the accelerometer seismic mass-spring system. Later it will be seen that this frequency is used to define the *useful operating frequency range* of an accelerometer.

In practice it is obviously not possible to mount the accelerometer on an infinitely heavy and stiff structure to measure its *mounted resonance frequency*. An approximation is achieved by mounting the accelerometer on a 180 g steel block and exciting the two together at a constant acceleration over a wide frequency range to measure the *mounted resonance frequency*. This is examined in Chapter 5.

The resonance frequency when mounted will change if the structure is not infinitely rigid or if the accelerometer mounting technique introduces an additional compliance between the base and the structure. The resonance will split up in two and the lowest resonance frequency will be lower than the mounted resonance frequency. This is examined in Chapter 4.

The forced vibration of the accelerometer must now be examined. The applied force on the accelerometer must be included in the analysis along with the natural resonance frequency, ω_n , previously defined. The equation of motion for the model (1) now becomes

$$\ddot{r} + \omega_n^2 r + \frac{F_0}{m_b} \sin \omega t = 0$$

and assuming again that the displacements of the masses vary sinusoidally then

$$-\omega^2 R \sin \omega t + \omega_n^2 R \sin \omega t + \frac{F_0}{m_b} \sin \omega t = 0$$

and therefore

$$R(\omega_n^2 - \omega^2) + \frac{F_0}{m_b} = 0$$

or

$$R = -\frac{F_0}{m_b (\omega_n^2 - \omega^2)}$$

At frequencies well below the natural resonance frequency of the accelerometer ($\omega \ll \omega_n$) the displacement, which is now called R_0 , is expressed by

$$R_0 = -\frac{F_0}{m_b \omega_n^2}$$

The ratio of the displacement at low frequency, R_0 , to the displacement at high frequency, R , can be expressed as follows

$$\frac{R}{R_0} = \frac{-\frac{F_0}{m_b (\omega_n^2 - \omega^2)}}{-\frac{F_0}{m_b \omega_n^2}}$$

and by denoting this ratio as A and rearranging the expression, then

$$A = \frac{1}{1 - \left(\frac{\omega}{\omega_n}\right)^2} \quad (4)$$

This important result shows that the displacement between the base and the seismic masses increases when the forcing frequency becomes comparable to

the natural resonance frequency of the accelerometer. Consequently the force on the piezoelectric elements and the electrical output from the accelerometer also increase. As the piezoelectric elements used in Brüel & Kjær accelerometers exhibit constant force sensitivity the increase in electrical output of an accelerometer near its resonance frequency is attributable entirely to the natural resonance of the accelerometer. The typical shape of a frequency response curve of an accelerometer (see Fig. 2.3) and amplitude measurement errors are related to this equation. This is covered in section 2.3.

The free hanging natural resonance frequency of the accelerometer depends heavily on the ratio of the total seismic mass to the mass of the rest of the transducer but primarily to that of the base. As a general rule the total seismic mass of an accelerometer is approximately the same as the mass of the base and this gives the relationship

$$\frac{\text{mounted resonance frequency}}{\text{free hanging resonance frequency}} \approx \frac{1}{\sqrt{2}}$$

2.3. Frequency Range

The relative change in electrical output from an accelerometer is shown in Fig. 2.3. A frequency response curve of this kind shows the variation in the accelerometer's electrical output when it is excited by a constant vibration level over a wide frequency range. To obtain such a frequency response curve the accelerometer is mounted onto a 180 g exciter head. Hence the approximation

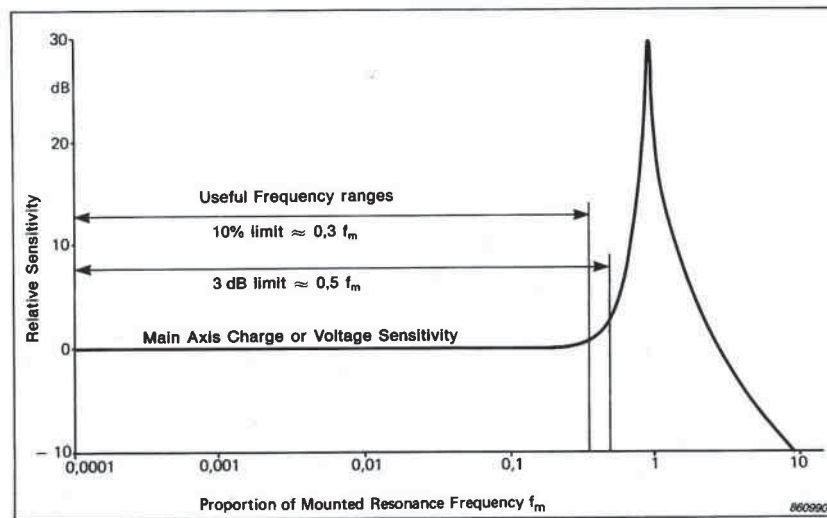

Fig. 2.3. Relative sensitivity of an accelerometer vs. frequency

to the *mounted resonance frequency* of the accelerometer can be found. This frequency response curve is related to equation (4) in the last section. However, the *mounted resonance frequency* can now be directly substituted into (4) to obtain

$$A = \frac{1}{1 - \left(\frac{\omega}{\omega_m}\right)^2} \quad (5)$$

Equation (5) can be used to calculate the deviation between the measured and the actual vibration at any frequency and to define useful frequency ranges.

2.3.1. Upper Frequency Limit

Fig. 2.3 shows that the *mounted resonance frequency* determines the frequency range over which the accelerometer can be used while a constant electrical output for a constant vibration input is still maintained.

The higher the mounted resonance frequency, the wider the operating frequency range. However, in order to have a higher mounted resonance frequency it is necessary to have either stiffer piezoelectric elements or a lower total seismic mass. The stiffness of the piezoelectric elements is generally constant so a lower seismic mass is required. Such a lower mass would however exert less force on the piezoelectric element and the accelerometer would consequently be less sensitive. Therefore accelerometers possessing very high frequency performance are less sensitive. Conversely, high sensitivity accelerometers do not have very high frequency measurement capability.

Several useful frequency ranges can be defined from the frequency response curve of an accelerometer. They are:

5% Frequency Limit is the frequency at which there is a 5% deviation between the measured and the actual vibration level applied to the base of the accelerometer. The maximum vibration frequency which can be measured with this accuracy is approximately one fifth (0,22) of the mounted resonance frequency of the accelerometer.

10% Frequency Limit is the frequency at which there is a 10% deviation between the measured and the actual vibration level applied to the base of the accelerometer. The maximum vibration frequency which can be measured with this accuracy is approximately one third (0,30) times the mounted resonance frequency of the accelerometer.

3dB Frequency Limit is the frequency at which there is a 3dB difference between the measured and the actual vibration level applied to the base of the

accelerometer. The maximum vibration frequency which can be measured with this accuracy is approximately one half (0,54) times the mounted resonance frequency of the accelerometer.

2.3.2. Lower Frequency Limit

Piezoelectric accelerometers are not capable of a true DC response. The piezoelectric elements will only produce a charge when acted upon by *dynamic* forces. The actual low frequency limit is determined by the preamplifier to which the accelerometer is connected as it is the preamplifier which determines the rate at which the charge leaks away from the accelerometer. Measurements of vibrations at frequencies down to 0,003 Hz are possible with Brüel & Kjær accelerometers and preamplifiers.

Applications requiring a low frequency limit in the order of fractions of a hertz are very rare and consequently the lack of a true DC response is seldom a drawback.

Chapter 3, "Vibration Preamplifiers", should be consulted for a description of the low frequency performance of preamplifiers. Environmental effects associated with low frequency measurements are covered in Chapter 4 "Accelerometer Performance in Practice".

2.4. PIEZOELECTRIC MATERIALS

A piezoelectric material is one which develops an electrical charge when subjected to a force. Materials which exhibit this property are intrinsic piezoelectric monocrystals such as quartz and Rochelle salt, and artificially polarized ferroelectric ceramics which are mixtures of different compounds such as barium titanate, lead zirconate and lead metaniobate.

The process by which the ceramics are polarized is analogous to the process by which a piece of soft iron can be magnetised by a magnetic field . A high voltage surge is applied across two ends of the material. The domains within the molecular structure of the material become aligned in such a way that an external force causes deformations of the domains and charges of opposite polarity to form on opposite ends of the material. Fig. 2.4. shows a simplified illustration of this effect. When a piezoelectric accelerometer is vibrated forces proportional to the applied acceleration act on the piezoelectric elements and the charge generated by them is picked up by the contact. It is the extremely linear relationship between the applied force and the developed charge, over a very wide dynamic and frequency range, which results in the excellent characteristics of the piezoelectric accelerometer. The sensitivity of a piezoelectric material is given in pC/N.

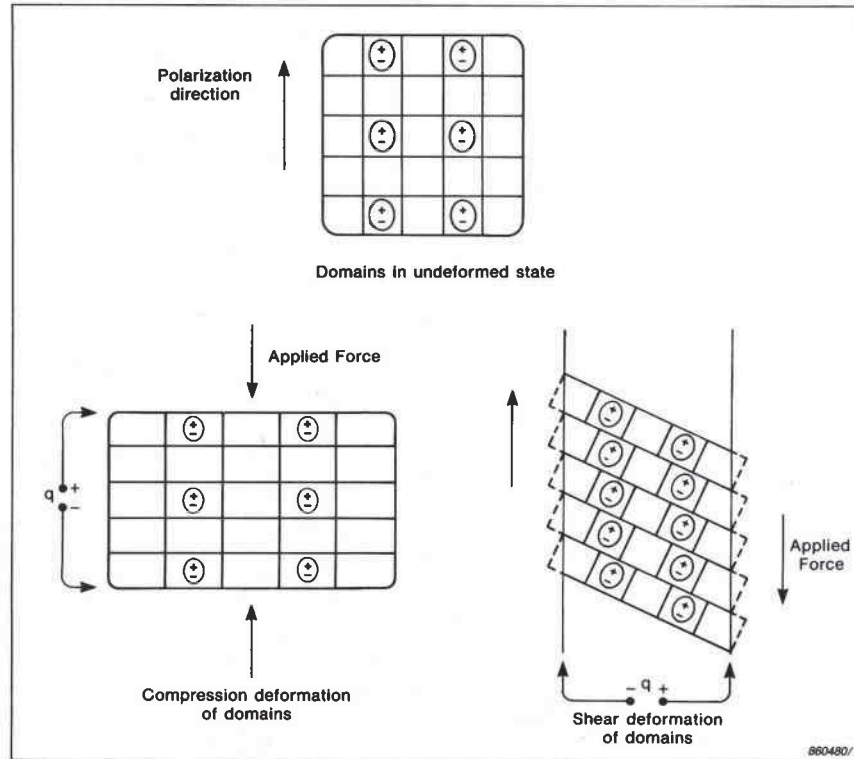

Fig. 2.4. Simple model of the piezoelectric effect within an artificially polarized ceramic. The charge q is collected between the indicated surfaces

The piezoelectric element can undergo both compression and shear deformation as illustrated in Fig. 2.4. In both cases a charge is developed along the surfaces on which the forces act.

In compression deformation the charge is picked up in the polarization direction. This has the distinct disadvantage that non-vibration inputs, such as temperature fluctuations, cause charge to be developed in the polarization direction. This charge is also picked-up along with the vibration induced charge and the accelerometer output is no longer only related to the vibration input. However, when using shear deformation, the charge is picked up in a direction perpendicular to the polarization direction and the extra charge caused by the temperature fluctuations is not picked up. This is one of the reasons why shear mode accelerometer designs give better performance than compression designs. The influence of temperature fluctuations is discussed in further detail in section 4.2.2.

Ferroelectric ceramics may be produced in any desired shape and their composition may be varied to give them special properties for different applications. With piezoelectric monocrystalline materials such as quartz this is not the case as their composition is fixed and their shape is restricted by the size of crystal from which they are cut. Because of this accelerometers which use monocrystalline elements generally have a lower sensitivity and internal capacitance than those with ferroelectric ceramic elements.

Piezoelectric materials used in Brüel & Kjær accelerometers are designated PZ 23, PZ 27, PZ 45 and PZ 100. These have the following properties:

1. PZ 23 belongs to the lead titanate, lead zirconate family of ferroelectric ceramics and is artificially polarized. It may be used at temperatures up to 250°C (482°F). Due to its high sensitivity (approx. 300 pC/N) and other good all round properties it is used in most Brüel & Kjær accelerometers.
2. PZ 27 is an artificially polarized lead zirconate titanate element very similar to PZ 23. It is suitable for use in miniature accelerometers.
3. PZ 45 is a specially formulated artificially polarized ferroelectric ceramic which has a particularly flat temperature response and may be used at temperatures of up to 400°C (752°F). It is used in Brüel & Kjær differential, high temperature and high shock accelerometers.
4. PZ 100 is a carefully selected and prepared quartz crystal. It may be used at temperatures up to 250°C (482°F) and has excellent stability with low temperature transient sensitivity. It is used in the Brüel & Kjær Standard Reference Accelerometer Type 8305 and in the force transducers.

The type of the piezoelectric element used in any particular Brüel & Kjær accelerometer can be found in the accelerometer Product Data.

2.5. PRACTICAL ACCELEROMETER DESIGNS

Three different mechanical constructions are used in the design of Brüel & Kjær accelerometers. The first two designs, Planar Shear and Delta Shear[®] are shown in Fig. 2.5. A Compression Design (see Fig. 2.6) is also in use. Due to its superior performance the Delta Shear[®] design is used in nearly all Brüel & Kjær accelerometers.

1. **Delta Shear[®] Design.** Three piezoelectric elements and three masses are arranged in a triangular configuration around a triangular centre post. They are held in place using a high tensile clamping ring. No adhesives or bolts are required to hold the assembly together and this ensures optimum performance and reliability. The ring prestresses the piezoelectric elements to give a high degree of linearity. The charge is collected between the housing and the clamping ring.

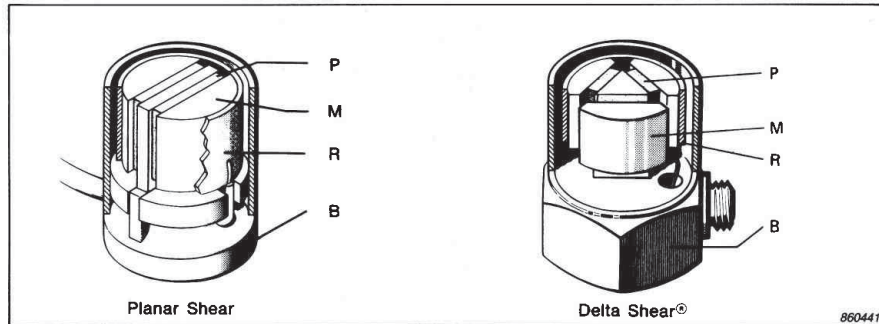

Fig. 2.5. Planar Shear and Delta Shear[®] designs. M=Seismic Mass, P=Piezoelectric Element, R=Clamping Ring and B=Base

The Delta Shear[®] design gives a high sensitivity-to-mass ratio compared to other designs and has a relatively high resonance frequency and high isolation from base strains and temperature transients. The excellent overall characteristics of this design make it ideal for both general purpose accelerometers and more specialized types.

2. **Planar Shear.** In this design the piezoelectric element undergoes shear deformation as in the Delta Shear[®] design. Two rectangular slices of piezoelectric material are arranged on each side of a rectangular centre post. Two masses are formed as shown in Fig. 2.5 and held in position using a high tensile strength clamping ring performing the same function as in the Delta Shear[®] design. The base and piezoelectric elements are effectively isolated from each other thus giving excellent immunity to base bending and temperature fluctuations.
3. **Centre Mounted Compression Design.** This traditional, simple construction gives a moderately high sensitivity-to-mass ratio. The piezoelectric element-mass-spring system is mounted on a cylindrical centre post attached to the base of the accelerometer. However, because the base and centre post effectively act as a spring in parallel with the piezoelectric elements, any dynamic changes in the base such as bending or thermal expansions can cause stresses in the piezoelectric elements and hence erroneous outputs. Even though Brüel & Kjær employ very thick bases to minimize these effects in compression designs, bending and stretching forces can still be transmitted to the piezoelectric elements. This will result in an erroneous non-vibration related output at the frequency of the vibration. In the previous section it was seen that temperature fluctuations can also produce charge in the piezoelectrics which are picked up in Compression Designs.

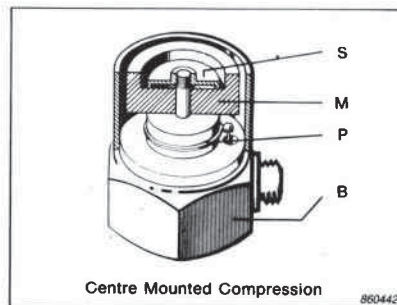

Fig. 2.6. Traditional Compression Design. M=Seismic Mass, P=Piezoelectric Element, B=Base, and S=Spring

For the reasons mentioned above Brüel & Kjær only produce compression design accelerometers for high level measurements (i.e. shock measurements) where the erroneous output is small compared with the vibration signal. A compression design is also used for the Standard Reference Accelerometer which is used in the controlled environment of accelerometer calibration. Here the addition of a beryllium disc strengthens the base and minimizes the effect of base bending. This accelerometer is inversely mounted in order to measure more accurately the vibration at the base of the accelerometer which is mounted onto it.

2.5.1. Line-drive Accelerometers

These accelerometers contain a built-in preamplifier. A line-drive accelerometer is shown in Fig. 2.7. The accelerometer part of this design is identical to the Delta Shear[®] construction mentioned above. The electronic part utilizes thick film micro-circuitry techniques to produce a preamplifier with excellent performance characteristics. Chapter 3 includes a description of the operation of the preamplifier section.

Line-drive accelerometers require an external power supply for their operation. The built-in preamplifier is supplied by a constant voltage and the vibration signal is transmitted back to the external supply unit in the form of the modulated power supply current. This system is also described in Chapter 3.

Built-in preamplifiers do however introduce temperature and shock limitations. To overcome this Brüel & Kjær also produce a separate line-drive preamplifier for use with accelerometers.

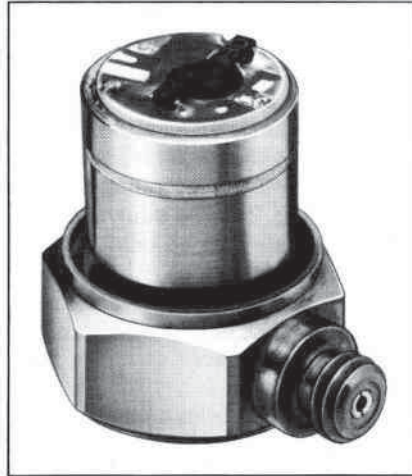

Fig. 2.7. A Brüel & Kjær line-drive accelerometer with its housing removed to reveal the built-in electronics

2.5.2. Other designs

Other designs of accelerometer exist, based around the compression and shear deformation principles. Brüel & Kjær only use the designs mentioned above as these, and in particular the Delta Shear[®] design, give the most uncompromising performance available. The following general designs may still be found elsewhere;

Annular Shear Designs where the piezoelectric elements and masses are formed into rings and simply glued together.

Isolated Shear (Bolted Shear) is similar to the planar shear design except the piezoelectric elements are secured using a bolt.

2.6. ACCELEROMETER SENSITIVITY

So far it has been seen that an accelerometer is a self-generating device whose electrical output is proportional to the applied acceleration. In order to assess the accelerometer's role as a measurement device, the relationship between its input (acceleration) and output (charge or voltage) is now examined in more detail.

2.6.1. Charge and Voltage Sensitivity

The piezoelectric accelerometer can be regarded as either a charge source or a voltage source. The piezoelectric element acts as a capacitor C_a in parallel with a very high internal leakage resistance, R_a , which, for practical purposes, can be ignored. It may be treated either as an ideal charge source, Q_a in parallel with C_a and the cable capacitance C_c or as voltage source V_a in series with C_a and loaded by C_c , as shown in Fig. 2.8. The equivalent circuits for both models are shown in Fig. 2.8. Both models can be used independently according to which model yields the easiest calculations.

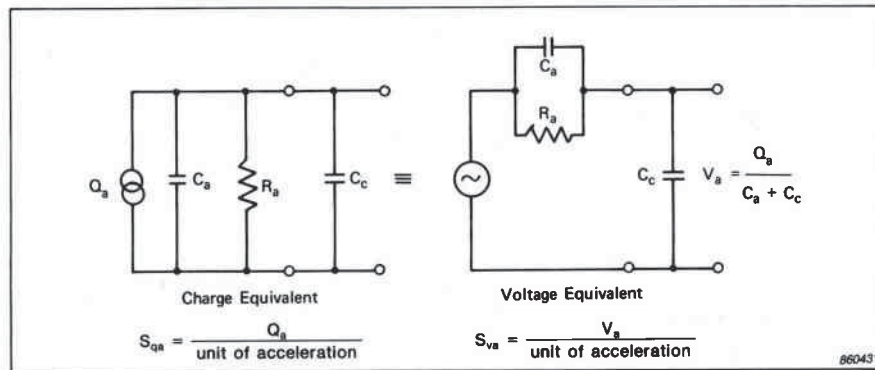

Fig. 2.8. Equivalent electrical circuits for piezoelectric accelerometer and connection cable

The choice of accelerometer preamplifier depends on whether we want to detect charge or voltage as the electrical output from the accelerometer.

The charge sensitivity, S_{qa} , of a piezoelectric accelerometer is calibrated in terms of charge (measured in pC) per unit of acceleration:

$$S_{qa} = \frac{\text{pC}}{\text{ms}^{-2}} = \frac{\text{pC}_{\text{RMS}}}{\text{ms}^{-2}_{\text{RMS}}} = \frac{\text{pC}_{\text{peak}}}{\text{ms}^{-2}_{\text{peak}}}$$

Likewise, the voltage sensitivity can be expressed in terms of voltage per unit of acceleration:

$$S_{va} = \frac{\text{mV}}{\text{ms}^{-2}} = \frac{\text{mV}_{\text{RMS}}}{\text{ms}^{-2}_{\text{RMS}}} = \frac{\text{mV}_{\text{peak}}}{\text{ms}^{-2}_{\text{peak}}}$$

It can be seen from the simplified diagrams that the voltage produced by the accelerometer is divided between the accelerometer capacitance and the cable capacitance. Hence a change in the cable capacitance, caused either by a different type of cable and/or a change in the cable length, will cause a change in the voltage sensitivity. A sensitivity recalibration will therefore be required. This is a major disadvantage of using voltage preamplification and is examined in greater detail in Chapter 3. Charge amplifiers are used nearly all the time nowadays.

At low and medium frequencies, within the useful operating frequency range of an accelerometer, the voltage sensitivity is independent of frequency. This also applies to the charge sensitivity of accelerometers using PZ 45 and PZ 100 piezoelectric materials, but not to those using PZ 23 and PZ 27 piezoelectric materials. Instead, this piezoelectric material has been designed so that both the charge sensitivity and capacitance decrease by approximately 2,5% per decade increase in frequency. The effect of this decrease is to partially offset the output rise at resonance. Therefore, the maximum deviation between the measured and actual accelerations over the useful operating frequency range of accelerometers employing PZ 23 with medium to high resonance frequencies is only $\pm 5\%$ of the acceleration applied to the base of the accelerometer, as indicated in Fig. 2.9.

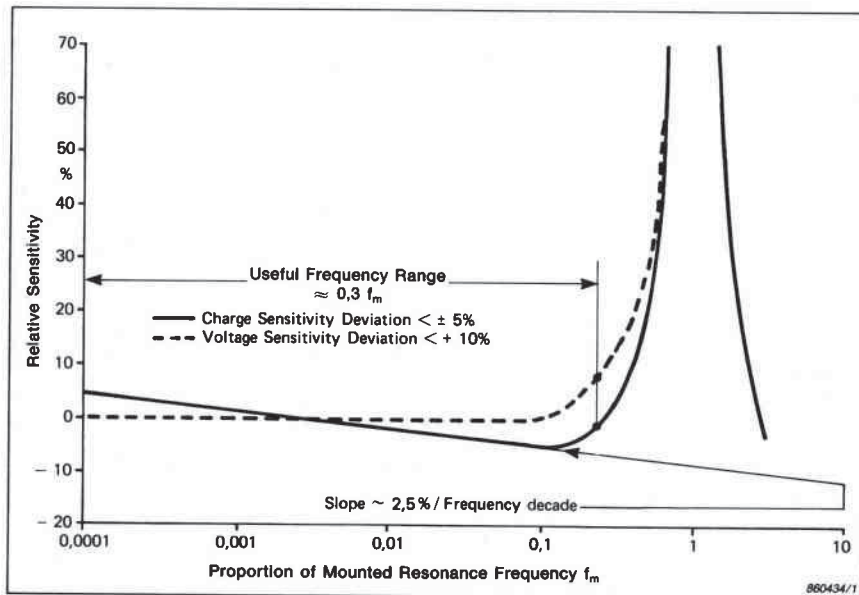

Fig. 2.9. Charge and voltage sensitivity versus frequency for an accelerometer using PZ 23 piezoelectric material

2.6.2. Uni-Gain[®] Sensitivity

Almost every Brüel & Kjær accelerometer is of the Uni-Gain[®] design. This means that their measured sensitivities have been adjusted to within 2% of a convenient value such as 1; 3,16; 10 or 31,6 pC/ms⁻². With Uni-Gain[®] accelerometers one accelerometer can be replaced by another of the same type without further adjustment of any instrument setting. Because the values above are 10 dB apart relative to each other, the calibration of measurement systems and set-ups is very easy. For example, if one accelerometer is exchanged for another of a different type, only fixed gain changes of 10 dB are required on the measurement instrumentation.

Uni-Gain[®] sensitivities are achieved in Brüel & Kjær accelerometers by carefully adjusting the mass of the seismic elements.

2.6.3. Linearity and Dynamic Range

Linearity is a fundamental requirement of any measuring system. The output from the system must be linearly related to the input over as wide a frequency and dynamic range as is required. The excellent linearity of Brüel & Kjær accelerometers is illustrated in Fig. 2.10.

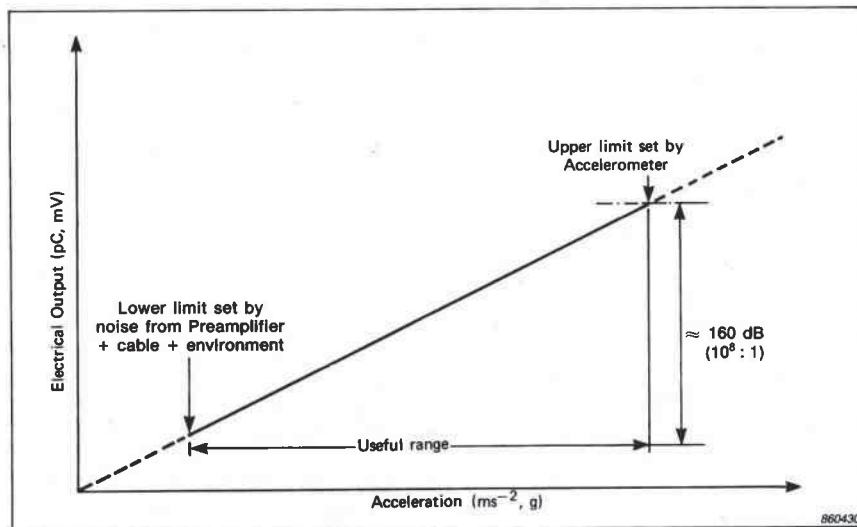

Fig. 2.10. Accelerometer output versus acceleration for piezoelectric accelerometers demonstrating the linearity and wide dynamic range

The piezoelectric accelerometer is an extremely linear device over a very wide dynamic range because of the linear performance of the piezoelectric elements over a wide dynamic range. In theory the accelerometer is linear down to zero acceleration. However a practical lower limit is determined by the noise inherent in the measurement system. This noise can have several sources of origin and these are discussed in Chapters 3 and 4.

When an accelerometer is taken beyond its maximum acceleration limit the performance becomes increasingly non-linear. At levels far in excess of the maximum limit the preloading ring might begin to slip down the piezoelectric elements and eventually short-circuit with the base, thus rendering the accelerometer useless. In practice this will never happen unless the accelerometer is subjected to shock levels well outside its specified operating range.

2.6.4. Transverse Sensitivity

When an accelerometer has acceleration applied at right angles to its mounting axis, there will still be some output from the accelerometer. On the accelerometer calibration chart the transverse sensitivity is quoted as a percentage of the main axis sensitivity. Ideally the transverse sensitivity of an accelerometer should be zero, but in practice minute irregularities in the piezoelectric element and in metal parts prevent this. At Brüel & Kjær particular attention is paid to selection of homogenous piezoelectric ceramics and to careful machining, polishing and lining up of accelerometer parts. Thus with proper handling and

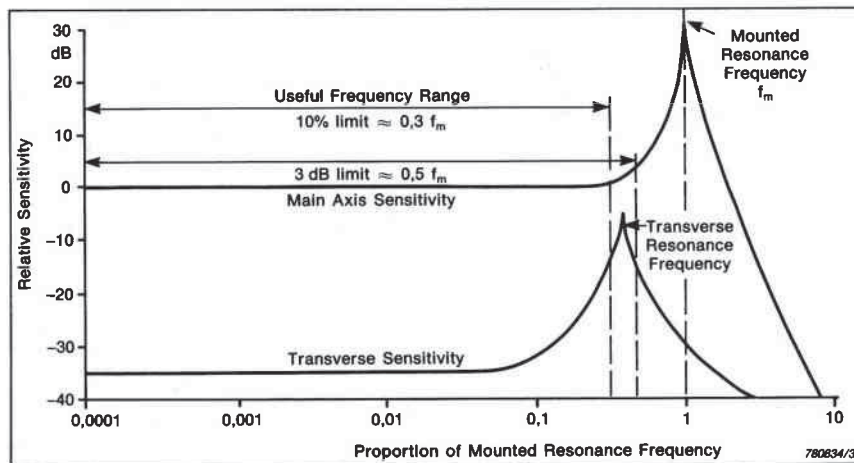

Fig. 2.11. The relative response of an accelerometer to main axis and transverse axis vibrations

mounting on a flat, clean surface, the maximum transverse sensitivity of most Brüel & Kjær accelerometers can be kept below 4% of the main axis sensitivity at 30 Hz (see Fig. 2.11).

At frequencies less than one sixth of the main axis mounted resonance frequency transverse sensitivity can be kept below 10%. At frequencies just over one third of the main axis mounted resonance frequency it is difficult to specify exact values of transverse sensitivity as transverse resonance occurs. This is indicated in Fig. 2.11.

As illustrated in Fig. 2.12, transverse sensitivity can be regarded as the result of the maximum charge and voltage sensitivity axis of the accelerometer not being quite aligned with the mounting axis. Because of this there are directions of maximum and minimum transverse sensitivity which are at right angles to one another and to the main sensitivity axis. It is therefore the maximum value of transverse sensitivity which is specified on the accelerometer calibration chart. The direction of minimum sensitivity is marked by a red dot on the accelerometer housing. This is a unique feature of Brüel & Kjær accelerometers.

It should be noted that the Delta Shear[®] design, having constant stiffness in all transverse directions, has only one transverse resonance. Other shear designs may have two or more transverse resonances.

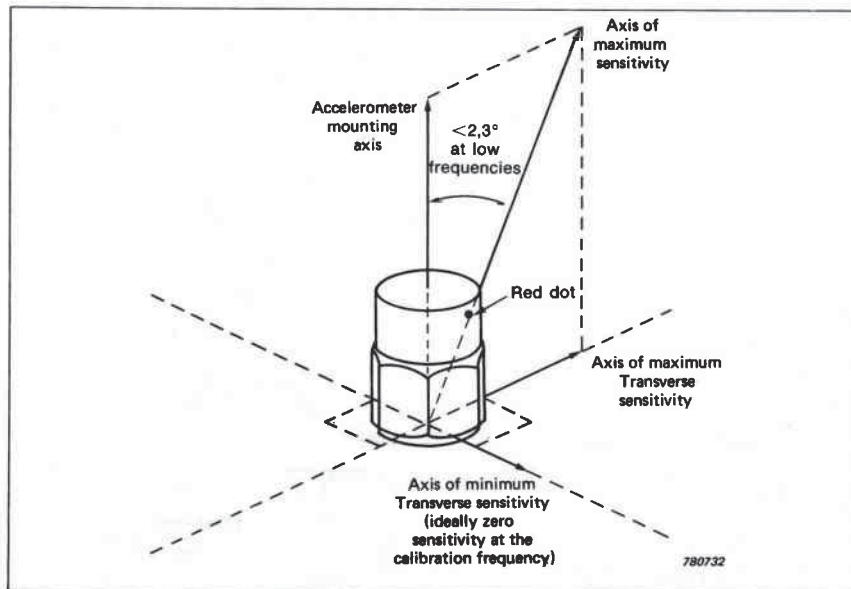

Fig. 2.12. Vectorial representation of transverse sensitivity

As the transverse resonance is just outside the useful operating frequency range of an accelerometer and with a peak amplitude just below the main axis sensitivity, it is important that transverse vibrations and shocks are kept well below the specified main axis continuous vibration limits. Similarly, dropping or banging accelerometers can subject them to large transverse shocks well outside practical design limits and permanent damage can be caused to the piezoelectric elements inside the accelerometer.

The following precautions can be taken against severe transverse vibrations:

1. Align the red dot in the direction of maximum transverse acceleration.

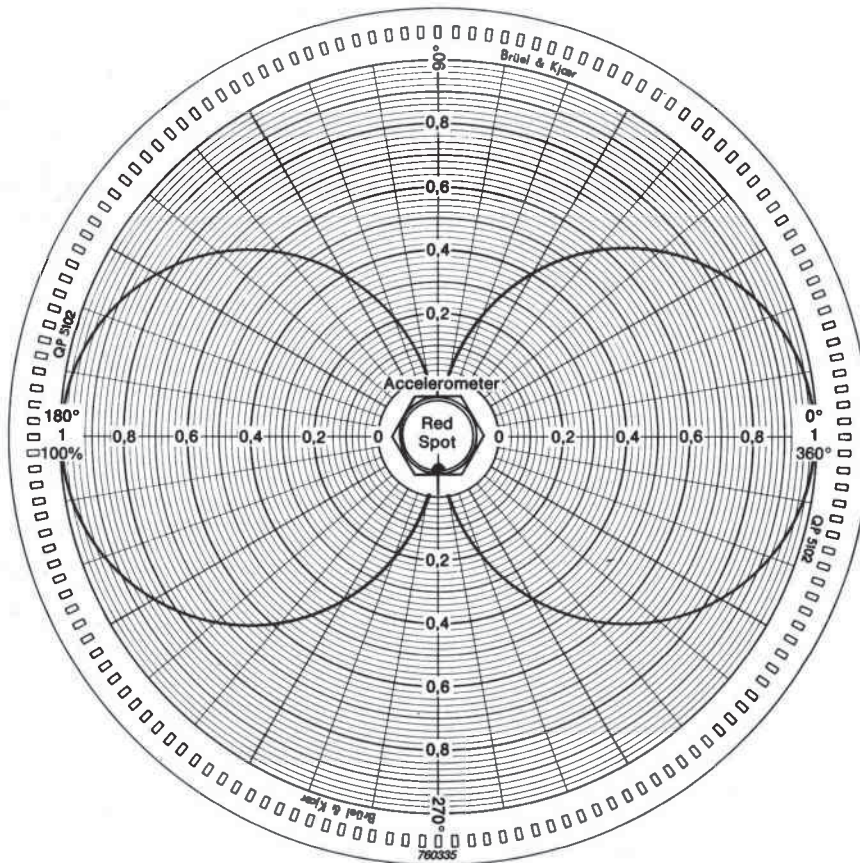

Fig. 2.13. Chart for determining the accelerometer transverse sensitivity in any direction when the maximum transverse sensitivity is known

2. Use a mechanical filter to filter off vibrations in directions other than the main axis.
3. Use the chart in Fig. 2.13 to calculate the sensitivity to vibrations in any direction from the maximum transverse sensitivity.

Example. At 60° to the maximum sensitivity axis of 0° the chart indicates a transverse sensitivity factor of 0,5. (This could also have been calculated from the cosine of the angle). Therefore an accelerometer having a maximum transverse sensitivity of 2% will have a transverse sensitivity at 60° of:

$$0,5 \times 2\% = 1\%$$

2.7. PHASE RESPONSE

The phase shift of an accelerometer corresponds to the time delay between the mechanical input and the resulting electrical output. If the phase is not constant at all frequencies in the operating range, the phase relationship between various frequency components of a vibration signal will be altered with respect to each other, resulting in an electrical output that is a distorted representation of the mechanical input.

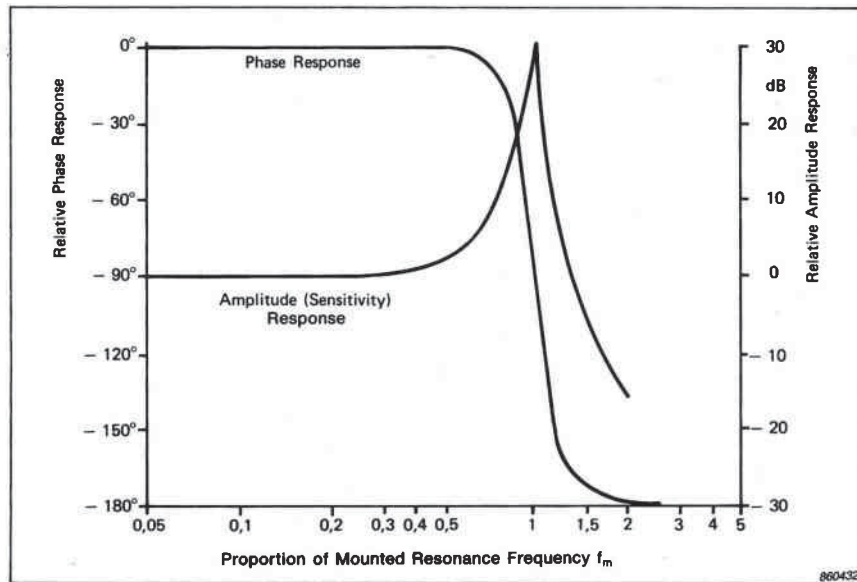

Fig. 2.14. Accelerometer amplitude and phase response as a function of frequency

The sensitivity and phase responses of an accelerometer are shown in Fig. 2.14. At frequencies below the mounted resonance the phase shift introduced is insignificant. At frequencies very close to the resonance, the motion of the seismic masses lags that of the base and phase distortion is introduced. However, with Brüel & Kjær accelerometers small resonance damping factors ensure that the frequency range over which resonance occurs is relatively narrow, and therefore the accelerometer may be operated well beyond its rated useful frequency range without introducing phase distortion.

Nevertheless, it is also necessary to consider the phase linearity of the charge or voltage preamplifier used, especially if integration networks and other filters are in use. This is especially important when measuring transient vibrations and mechanical shocks.

2.8. TRANSIENT RESPONSE

When measuring transient vibrations and shocks particular attention must be paid to the overall linearity of the system as otherwise the reproduced transients will be distorted. Piezoelectric accelerometers are extremely linear transducers and will reproduce a wide range of transients without problem. The accelerometer is the least frequent source of error when poor measurements are made of transients. More often it is the preamplifier and any associated filters and integration networks which cause the problem. However, to ensure the accuracy of the measurement it is necessary to consider the following transient phenomena.

2.8.1. Leakage Effects

In Fig. 2.15, a distortion has taken place in the waveform of a quasi-static acceleration pulse, such as might be encountered during a rocket launch or in a fast elevator. The distortion is caused by the accelerometer and preamplifier combination operating in the incorrect frequency range and can be explained as follows:

When the accelerometer is subjected to a quasi-static acceleration a charge is developed on the piezoelectric elements. By virtue of the elements capacitance, this charge is stored in the element and prevented from "leaking away" by the very high leakage resistance of the accelerometer. However, due to the finite leakage time constant of the accelerometer and the input impedance and lower limiting frequency setting on the preamplifier, some charge leaks away and this results in a negative slope waveform as seen between points A and B. When the acceleration stops, the charge changes a corresponding amount and drops below the zero level to point C before rising back up to the zero level

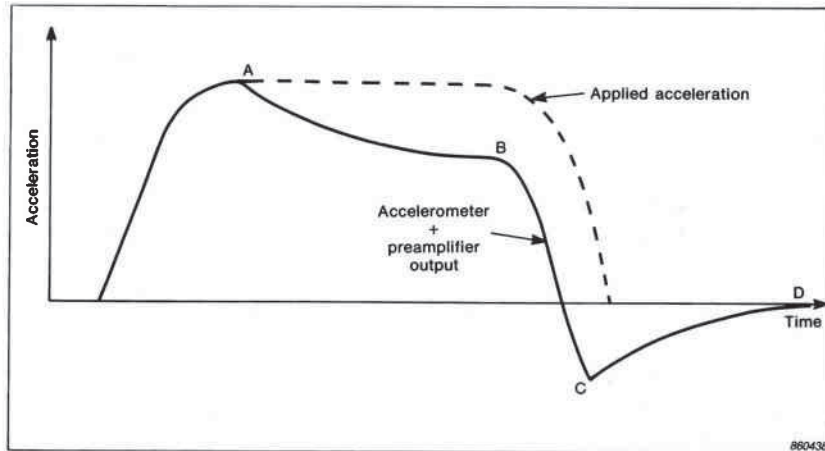

Fig. 2.15. The distortion of a waveform of a quasi-static acceleration input caused by "leakage" associated with the accelerometer and preamplifier

again at point D. The rate of exponential change between A and B and between C and D is the same and is determined by the time constant set by the accelerometer and preamplifier.

This effect causes errors in the measurement of the peak amplitude of the acceleration and is caused by the accelerometer being used with the wrong Lower Limiting Frequency on the preamplifier. Measurement errors of peak amplitude due to leakage may be kept to within 5% by ensuring that the -3dB Lower Limiting Frequency of the preamplifier is less than $0,008/T$, where T is the period of a *square wave* transient. For measurements on half-sine transients the Lower Limiting Frequency must be less than $0,05/T$.

The frequency bandwidth of the entire measurement system required to measure such transients with specified accuracies can be found from Fig. 2.16 which also includes the upper frequency requirement because transient signals have higher frequency components which must also be reproduced without distortion.

The distortion of the waveform of transients, and in particular quasi-static vibrations, caused by using the accelerometer with the incorrect frequency range can appear similar to the distortion produced by other phenomena such as zero shift (see section 2.8.3). It must be understood that the causes, and hence solutions, of the problems are different.

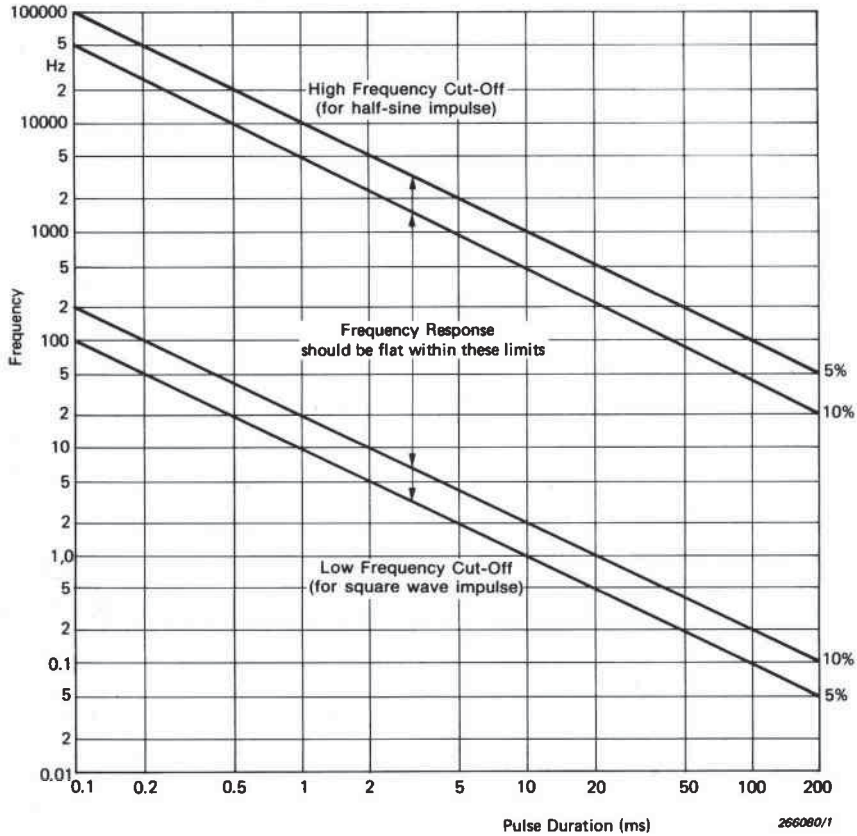

Fig. 2.16. *Vibration system -3dB lower and upper limiting frequencies required for acceleration measurements of pulses of duration T keeping amplitude measurement errors less than 5 and 10% respectively*

2.8.2. "Ringing"

This term is used to describe the distortion produced by an accelerometer which is being used to measure transient vibrations outside its useful frequency range. An example of the resulting distorted signal is shown in Fig. 2.17. The resonance of the accelerometer is excited with high frequency vibration components and this should be avoided. A first warning of ringing might be given by an overload indication on the preamplifier.

"Ringing" causes errors in the measurement of peak vibration amplitude. For 5% peak measurement error the accelerometer mounted resonance frequency should not be less than $10/T$ where T is the length of the transient in seconds.

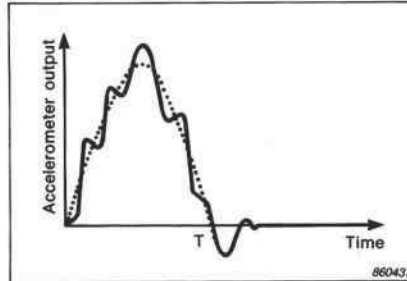

Fig. 2.17. Waveform distortion due to "ringing"

The accelerometer resonance can be damped to reduce the ringing and make optimum use of the measurement system dynamic range and bandwidth. This may be achieved using a mechanical filter for mounting the accelerometer (see section 4.5) or by applying the accelerometer signal to a preamplifier incorporating a low-pass filter. In the latter case the filter must have a high frequency attenuation slope of 12 dB/octave and a -3 dB upper limiting frequency f_u corresponding to approximately half the accelerometer mounted resonance frequency f_m (i.e. $f_u = 0,5 f_m$). This gives the system response shown in Fig. 2.18, enabling a half-sine wave transient of duration $T = 1 / f_m$ to be measured with less than 10% amplitude error.

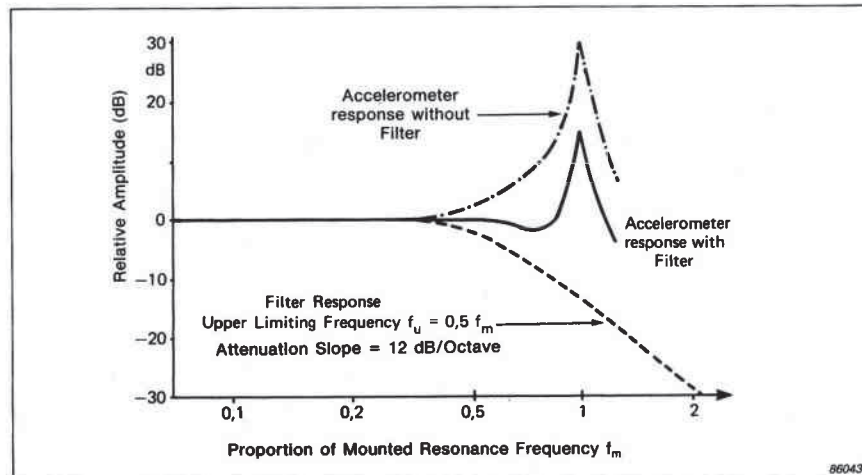

Fig. 2.18. Low pass filter or preamplifier response required to damp mounted resonance frequency f_m of accelerometer for measurement of half sine type shock pulses of duration $T=1/f_m$ seconds with less than 10% amplitude error

2.8.3. Zero Shift

Consider the accelerometer output signals in Fig. 2.19 resulting from two identical half sine pulses. In both cases distortion of the waveform has been introduced by the accelerometer. The measurement dynamic levels were very close to the maximum acceleration limit of the accelerometer.

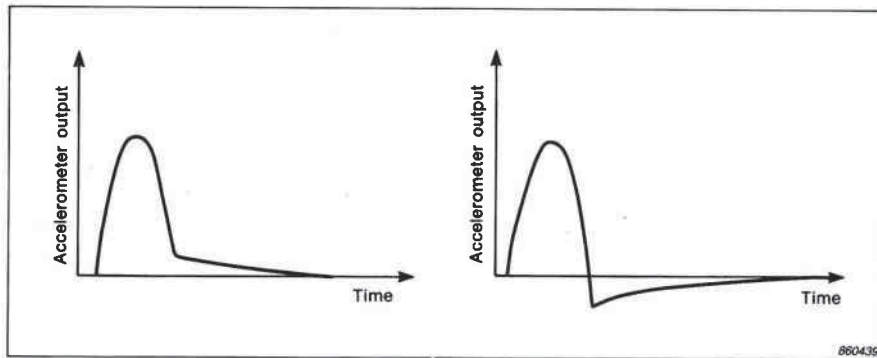

Fig. 2.19. Accelerometer and preamplifier output resulting from a half-sine pulse of such a high level that “zero shift” has been introduced

If the piezoelectric elements are not considered to be perfectly elastic materials, then when the force on the element is suddenly decreased the molecular domains may not all return to the state they were in before the shear force was applied. Therefore, when the force is removed the elements still produce a charge which slowly decays with time as the preamplifier output returns to zero at a rate determined by its Lower Limiting Frequency. This phenomenon occurs randomly and with random sign.

The time taken for the zero shift to disappear may be a factor of 1000 times longer than the length of the original pulse. Therefore, large errors result if integration networks are used.

A mechanical filter can often guard against zero shift effects.

REMEMBER: Zero shift, “Leakage” and “Ringing” are only problems when the accelerometer is used outside its useful operating ranges.

3. VIBRATION PREAMPLIFIERS

Vibration Preamplifiers perform the essential role of converting the high impedance output of the piezoelectric accelerometer into a low impedance signal suitable for direct transmission to measuring and analyzing instrumentation.

In addition to this, the preamplifier may also perform some, or all, of the following roles:

1. Matching measuring instrumentation input sensitivity to that of the accelerometer output.
2. Amplification of the vibration signal to obtain a desired overall system sensitivity.
3. Integration of the accelerometer output to obtain velocity and displacement signals.
4. Warning of overload at both the input and output of the preamplifier.
5. Low and high frequency filtering to reject unwanted signals.

The complete range of general purpose Brüel & Kjær vibration preamplifiers can be seen in Fig. 3.1. Brüel & Kjær preamplifiers are available in the following forms.

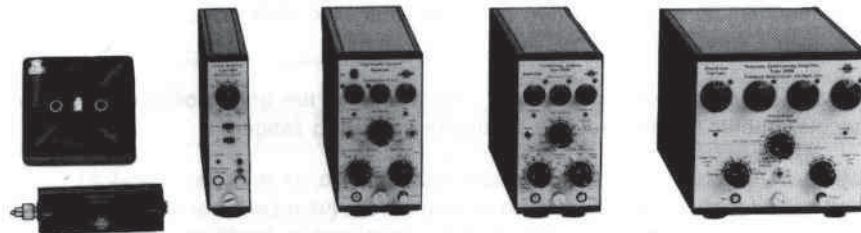

Fig. 3.1. The range of vibration preamplifiers available from Brüel & Kjær

1. Stand-alone units which perform most of the roles mentioned above. They can be either battery powered or mains powered. A summary of these instrument types is given in Appendix E.
2. As part of the input circuitry of measuring instruments such as vibration meters or in the form of input modules for tape recorders etc. A summary of these instruments is found in Appendix F.
3. Line-drive preamplifiers which are considerably different from both (1) and (2). They are miniature devices containing only the "front end" of a conventional preamplifier in a miniaturized form which is either built into, mounted directly onto, or placed near to the accelerometer. Only one two-conductor or coaxial cable is required for both signal transmission and power supply. Line-drive preamplifiers are fixed gain devices with no controls.

3.1. PREAMPLIFIER DESIGN AND OPERATION

There are two basic types of preamplifiers which may be used with piezoelectric accelerometers.

1. Charge Preamplifiers. These produce an output voltage proportional to the input charge. They do not amplify charge!
2. Voltage Preamplifiers. These produce an output voltage proportional to the input voltage.

Charge preamplifiers are generally used in preference to voltage preamplifiers. This is reflected in the current range of Brüel & Kjær preamplifiers where only the Type 2650 offers both a charge and voltage input. This preamplifier is designed for use in accelerometer calibration rather than general vibration measurements. The distinct advantage of charge amplifiers is that both very short and very long cables can be used without changing the overall sensitivity of the system. However, when a voltage preamplifier is used a change in cable length will necessitate a recalibration of the system sensitivity. This is discussed in section 2.6.1.

3.2. CHARGE AMPLIFIERS

A charge amplifier uses an operational amplifier input stage. The configuration of the operational amplifier with the capacitor in the feedback loop operates as an integration network and integrates the current at the input. This input current is the result of the charge developed across the high impedance piezoelectric elements inside the accelerometer. The amplifier works to nullify this current and in doing so produces an output voltage proportional to the charge.

3.2.1. Charge Sensitivity

The voltage output of a charge amplifier is proportional to the charge at the input and therefore to the acceleration of the accelerometer. The gain is controlled by the feedback capacitance across the operational amplifier.

Fig. 3.2. shows an equivalent circuit for a piezoelectric accelerometer connected to a charge preamplifier. The nomenclature below refers to this figure.

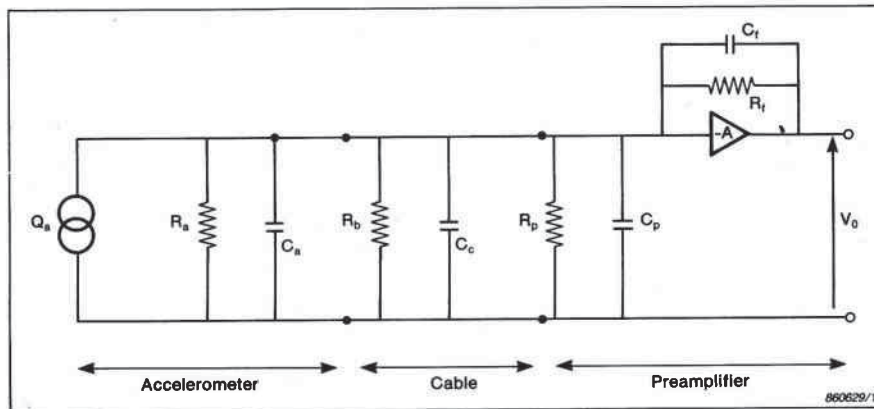

Fig. 3.2. An equivalent circuit for an accelerometer and cable connected to a charge amplifier

- Q_a = charge generated by the piezoelectric elements (proportional to the applied acceleration)
- C_a = capacitance of accelerometer
- R_a = resistance of accelerometer
- C_c = capacitance of cable and connectors
- R_b = resistance between cable screen and centre conductor
- C_p = capacitance of preamplifier input
- R_p = resistance of preamplifier input
- C_f = feedback capacitance
- R_f = feedback resistance
- A = gain of operational amplifier
- V_o = voltage output of the preamplifier

Normally the resistances of the accelerometer, preamplifier input and feedback path can be kept very high. Consequently the circuit in Fig. 3.2 can be

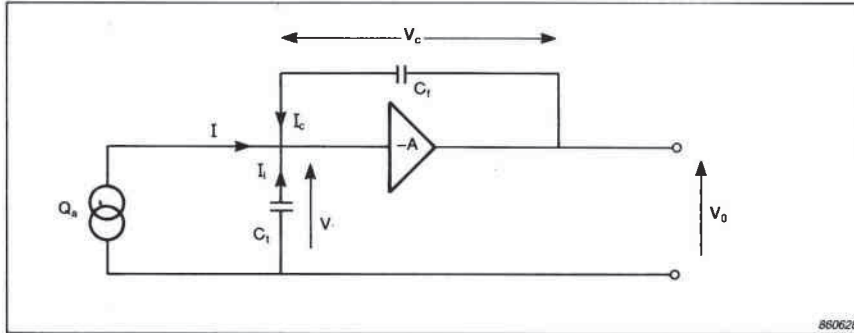

Fig. 3.3. Simplified equivalent circuit of an accelerometer connected to a charge preamplifier

reduced to the one shown in Fig. 3.3 where the total capacitance and currents flowing are shown

$$\begin{aligned}
 C_t &= C_a + C_c + C_p \\
 I &= \text{total current flowing out of the accelerometer} \\
 I_i &= \text{current from } C_t \\
 I_c &= \text{current in the feedback loop of the operational amplifier} \\
 V_c &= \text{voltage across feedback capacitance}
 \end{aligned}$$

The input and output voltages, V_i and V_o are related by the equation

$$V_o = -A V_i$$

Furthermore V_c can easily be calculated since

$$V_c = V_o - V_i = V_o - \frac{V_o}{-A} = \left(1 + \frac{1}{A}\right) V_o$$

An ideal amplifier has zero input current. Kirchhoff's laws apply to the currents shown in Fig. 3.3.

$$I + I_i + I_c = 0$$

These currents can be defined in terms of other circuit parameters. I is related to the charge produced by the piezoelectric elements.

$$I = \frac{dQ_a}{dt}$$

$$I_c = C_f \frac{dV_c}{dt} = \left(1 + \frac{1}{A}\right) C_f \frac{dV_o}{dt}$$

$$I_i = -C_f \frac{dV_i}{dt} = \frac{1}{A} C_f \frac{dV_o}{dt}$$

By substituting these expressions into Kirchhoff's equation the current from the accelerometer is found

$$\frac{dQ_a}{dt} = -\left(1 + \frac{1}{A}\right) C_f \frac{dV_o}{dt} - \frac{1}{A} C_f \frac{dV_o}{dt}$$

This equation can be solved by integration. Constants corresponding to any DC offset voltage initially present at the amplifier output are assumed to be zero. Such offsets will disappear rapidly as the preamplifier is in use. The solution to the equation then becomes

$$V_o = -\frac{Q_a}{\left(1 + \frac{1}{A}\right) C_f + \frac{1}{A} C_f} \quad (1)$$

When the magnitude of A is considered ($\approx 10^5$) the solution can be further reduced to the simple expression

$$V_o = -\frac{Q_a}{C_f} \quad (2)$$

It is clear from this that the output voltage is proportional to the input charge and therefore to the acceleration of the accelerometer. The gain of the preamplifier is determined by the feedback capacitance.

The input capacitance has no effect on the resulting output voltage because, in the ideal case ($A \rightarrow \infty$), the input voltage is zero.

$$V_i = -\frac{V_o}{A} = 0$$

Consequently, the finite input resistance has no effect on the output voltage. This means that only the currents from the accelerometer and the feedback capacitor flow at the input point and these currents are equal in magnitude but are of opposite polarity. It now appears that all the charge flows from the accelerometer to the feedback capacitor.

So much for the simpler models but what about a more realistic model which takes in the contributions of R_a , R_b and R_p ? A model of this kind is shown in Fig. 3.4 and the combined resistances, R_t , and capacitances, C_n , at the input are shown. The circuit now incorporates all the elements of Fig. 3.2. The equations now become

$$\frac{1}{R_t} = \frac{1}{R_a} + \frac{1}{R_b} + \frac{1}{R_p}$$

$$\begin{aligned}
V_o &= -AV_i \\
V_c &= \left(1 + \frac{1}{A}\right) V_o \\
I_c &= C_f \frac{dV_c}{dt} + \frac{V_c}{R_f} \\
&= \left(1 + \frac{1}{A}\right) \left[C_f \frac{dV_o}{dt} + \frac{V_o}{R_f} \right] \\
I_i &= -C_i \frac{dV_i}{dt} - \frac{V_i}{R_i} = \frac{1}{A} \left[C_f \frac{dV_o}{dt} + \frac{V_o}{R_f} \right] \\
\frac{dQ_a}{dt} &= -\left(1 + \frac{1}{A}\right) \left[C_f \frac{dV_o}{dt} + \frac{V_o}{R_f} \right] - \frac{1}{A} \left[C_f \frac{dV_o}{dt} + \frac{V_o}{R_f} \right]
\end{aligned}$$

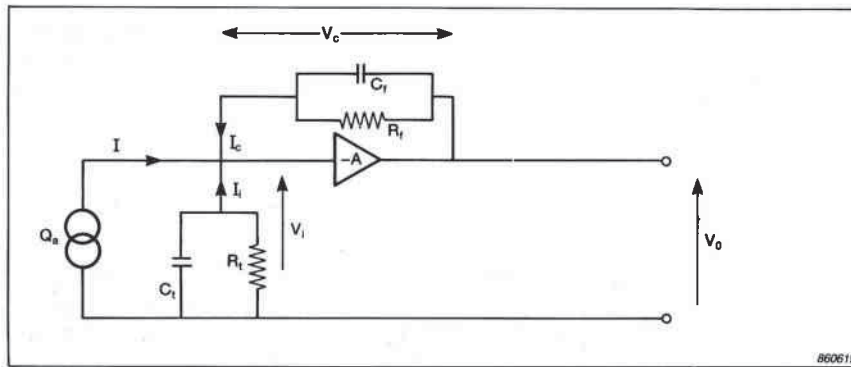

Fig. 3.4. Equivalent circuit for an accelerometer connected to a charge pre-amplifier

This equation cannot be solved using simple integration as in the previous model. However, by assuming that the voltages and currents vary harmonically with time a solution can be obtained. Once again the DC terms and initial conditions which disappear rapidly can be ignored in the analysis. The solution becomes

$$j\omega Q_a = -\left(1 + \frac{1}{A}\right) \left[j\omega V_o C_f + \frac{V_o}{R_f} \right] - \frac{1}{A} \left[j\omega V_o C_f + \frac{V_o}{R_f} \right]$$

This can be rearranged to obtain the output voltage V_o

$$V_o = - \frac{Q_a}{\left(1 + \frac{1}{A}\right) \left(C_f + \frac{1}{j\omega R_f}\right) + \frac{1}{A} \left(C_f + \frac{1}{j\omega R_f}\right)} \quad (3)$$

Again assuming that both A and R_f are very large the same relationship as before is derived

$$V_o = - \frac{Q_a}{C_f} \quad (4)$$

If R_f is finite then the expression can be written to include its effect

$$V_o = - \frac{Q_a}{C_f \left(1 + \frac{1}{j\omega R_f C_f}\right)} \quad (5)$$

Hence, with Q_a being proportional to the acceleration of the accelerometer, the overall sensitivity of the accelerometer/preamplifier combination can be controlled by varying C_f . In addition, the final equation shows that by varying the time constant of the feedback loop the low frequency response of the charge amplifier is controlled.

3.2.2. Lower Limiting Frequency

The low frequency response of a charge amplifier is determined by the time constant set by the feedback circuit around the operational amplifier and is unaffected by changes in the input load conditions. The lower limiting frequency is changed by varying the feedback resistance.

Accelerometers are self-generating devices and therefore have no true DC response. From the fundamentals of physics it is obvious that no power is obtainable from a device without some power input to that device. A static force on the piezoelectric elements does not provide any input power.

To fully understand the low frequency performance of charge amplifiers (and voltage amplifiers) it is necessary to understand the operation of simple RC networks.

A capacitor is a charge storage device. Its capacitance is defined as the quantity of charge stored at a unit voltage across the capacitor. The following equations define the relationships between the voltage, V , current, I , charge, Q ,

and capacitance, C , for an ideal capacitor, or in this case, for the piezoelectric elements.

$$V = \frac{Q}{C}$$

$$I = \frac{dQ}{dt}$$

$$I = C \frac{dV}{dt}$$

If an ideal capacitor is charged to a certain voltage, V_0 the voltage appearing across it will be stored. This is because an ideal capacitor has perfect DC isolation (i.e infinite leakage resistance). However in a real capacitor the isolation resistance is finite. The stored charge leaks away and the voltage drops exponentially at a rate determined by the time constant τ of the system. This is illustrated in Fig. 3.5.

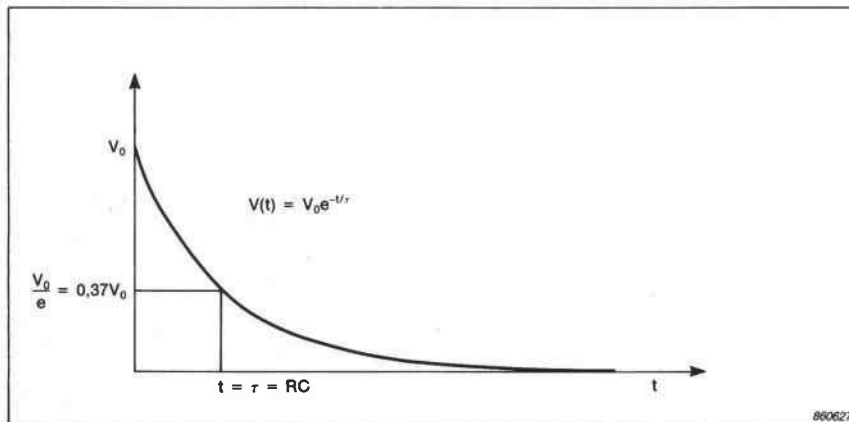

Fig. 3.5. The exponential decay of the voltage across a capacitor demonstrating the concept of the "time constant", τ

For measurements on sinusoidal signals the time constant τ has a particular significance. It affects the low frequency performance of the system. Take the charge source (the piezoelectric elements) and load it with several RC networks. This is shown in Fig. 3.6. The combined resistances and capacitances are represented as single components.

Using the definitions given above the circuit equation can be simply written.

$$= \frac{dQ}{dt} = \frac{V}{R} + C \frac{dV}{dt}$$

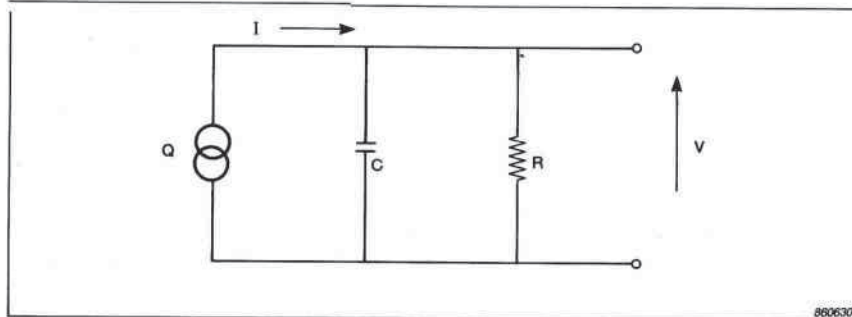

Fig. 3.6. Equivalent circuit of an accelerometer loaded by the equivalent capacitance and resistance of the cable and preamplifier. This model can be used to examine the low frequency performance of preamplifiers

Once again if the currents and voltages are assumed to be harmonic functions, the following can be derived

$$\begin{aligned}
 V &= \frac{Q}{\left(1 + \frac{1}{j\omega RC}\right) C} = \frac{Q}{\left(1 + \frac{1}{j\omega\tau}\right) C} \\
 &= \frac{Q \left(1 + j\frac{1}{\omega\tau}\right)}{\left(1 + \frac{1}{\omega^2\tau^2}\right) C}
 \end{aligned}$$

DC values and initial conditions have been omitted to make the analysis simpler. The complex expression shows that the output has a magnitude $|V|$ and phase angle ϕ relative to the input given by

$$\begin{aligned}
 \tan\phi &= \frac{1}{\omega\tau} \\
 |V| &= \frac{Q \sqrt{1 + \left(\frac{1}{\omega\tau}\right)^2}}{\left(1 + \left(\frac{1}{\omega\tau}\right)^2\right) C}
 \end{aligned}$$

When $\omega\tau = 1$, $\tan\phi = 1$, $\phi = 45^\circ$ and $V = \frac{Q}{\sqrt{2} C}$

The phase and amplitude relationship between input and output voltages as a function of $\omega\tau$ is shown in Fig. 3.7. The frequency when $\omega\tau = 1$ ($2\pi fRC = 1$) is

$$f_l = \frac{1}{2\pi RC} = \frac{1}{2\pi\tau}$$

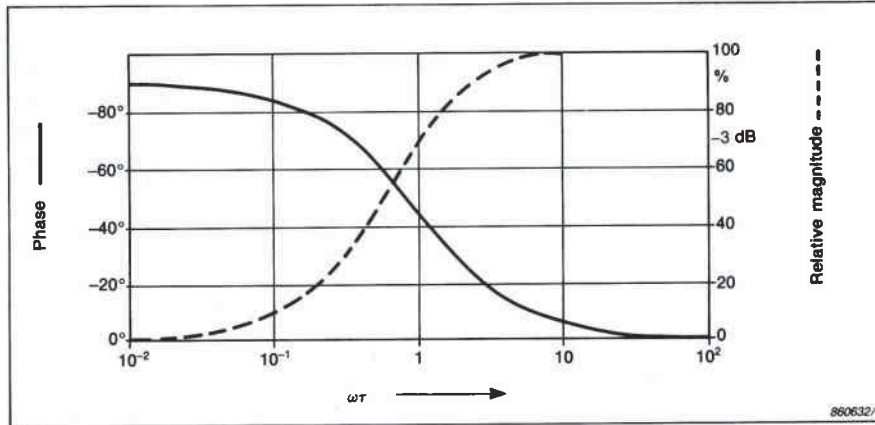

Fig. 3.7. The phase and amplitude relationship between input and output voltage as a function of $\omega\tau$

This is normally referred to as the Lower Limiting Frequency (LLF) and is characterized by a 3dB drop in the output signal level accompanied by a 45° phase change.

To return to charge preamplifiers it is seen from equation (3) in section 3.2.1 that the LLF is determined by the time constant of the feedback circuit i.e. $\tau_f = R_f C_f$. The phase difference between the input and the output is normally -180° (phase inversion) and at the LLF it is further delayed by 45°. From (3) it can also be seen that the resistive input load will not change the LLF until it becomes comparable to R_f / A . This means that provided that C_f and C_i are of a similar magnitude, the influence of the load has been reduced by a factor of A compared to the simple RC-network discussed.

Example: If an LLF of 1 Hz is required, what value for R_f is required?

Assuming that A is approximately 10^5 and C_f is about 1 nF then

$$R_f = \frac{1}{2\pi C_f}$$

$$R_f = \frac{1}{2\pi \cdot 10^5 \cdot 10^{-9}} = 1,6 \text{ k}\Omega$$

This example illustrates the immunity of the Lower Limiting Frequency of a charge amplifier to changes in the input load conditions. It would be very difficult to make the combined resistances of the accelerometer, connectors and preamplifier input drop to the magnitude indicated in this example. Even complete immersion of the accelerometer in water would not cause this.

Brüel & Kjær Charge Preamplifiers offer LLFs down to fractions of a Hertz. A low frequency capability is necessary for the measurement of long duration impulses and quasi-static vibrations. Such measurements however are only possible using Delta Shear[®] accelerometers because other accelerometer designs normally produce environmentally induced low frequency noise which will mask the vibration related output.

3.2.3. Capacitive Loading of the Input by Accelerometer Cables

The sensitivity of a charge amplifier is not significantly affected by the changes in capacitance caused by changing cable lengths. When very long cables are used the high frequency response is slightly attenuated.

It has already been shown that the output from a charge preamplifier is determined only by the feedback capacitance, C_f and the charge produced by the piezoelectric elements Q_a . In a typical charge amplifier the value of C_f is normally between 100 pF and 10 nF but is typically 1 nF giving an output sensitivity of 1 mV/pC. This will not change unless C_f becomes comparable to AC_f . A short example will demonstrate the extent of the charge amplifier's immunity to changes in cable capacitance.

Example: What is the maximum cable length that may be used if the charge sensitivity of the accelerometer-preamplifier combination must not change by more than 1%?

Assuming C_f and C_a are 1 nF and A is 10^5 then from equation (1) in section 3.2.1

$$V_o = - \frac{Q_a}{\left(1 + \frac{1}{A}\right) C_f + \frac{1}{A} C_t}$$

$$C_t = 0,01 (A + 1) C_f = 0,01 (10^5 + 1) 1 \text{ nF} = 10^3 \text{ nF} = 1 \mu\text{F}$$

This capacitance corresponds to 10 000 m of cable of capacitance 100 pF/m.

Large capacitive loading of the preamplifier input can have a slight effect on its high frequency performance. This is due to the fact that the gain of operational amplifiers decreases at high frequencies. Consequently, the assumption that A is infinite in the analysis leading to the definition of charge sensitivity, is less accurate. The output of the charge amplifier is reduced as shown by the equation for the output voltage derived earlier

$$V_o = - \frac{Q_a}{\left(1 + \frac{1}{A}\right) \left(C_f + \frac{1}{j\omega R_f}\right) + \frac{1}{A} \left(C_t + \frac{1}{j\omega R_t}\right)}$$

Example: Assume that the gain A is reduced to 10^3 at high frequencies and that the feedback capacitance C_f is 1 nF. An input load of 20 nF corresponding to 200 m of 100 pF/m transducer cable exists. This load will give a sensitivity drop of 5% in the frequency response curve and therefore this effect will not normally be of any significance.

Fig. 3.8 shows how the increase in input capacitance caused by very long cables effects the high frequency response of a Brüel & Kjær charge preamplifier. For specific cases consult the relevant Instruction Manuals.

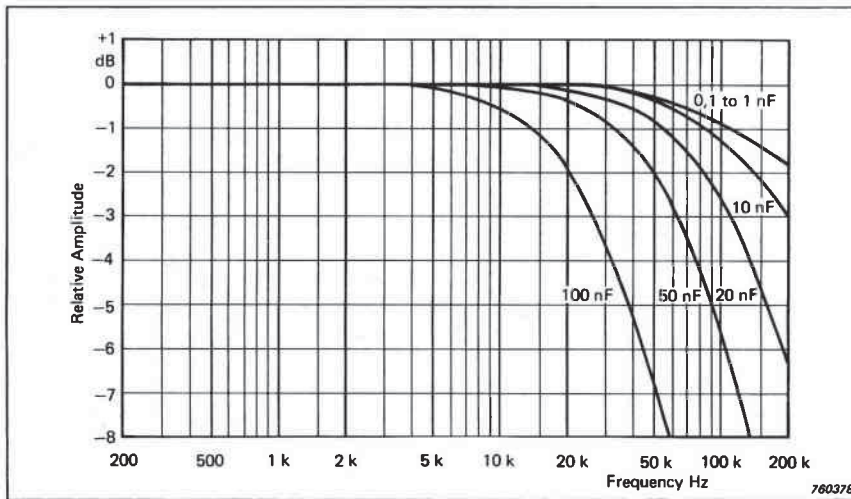

Fig. 3.8. Influence of the input load capacitance on the high frequency response of a Brüel & Kjær charge amplifier

3.2.4. Charge Attenuation

Although the addition of a further shunt capacitance will have negligible influence on the charge sensitivity, the addition of a series capacitance will reduce the effective transducer output charge. This is sometimes desirable when measuring high level vibrations using a high sensitivity accelerometer. The input to the preamplifier can be overloaded by the large charge. By adding carefully chosen calibrated capacitances in series and parallel with the accelerometer, the charge at the input can be attenuated. This is shown in Fig. 3.9.

Alternatively ready-made charge attenuators are available from Brüel & Kjær. These are available under the numbers WB0726* and WB0778* which provide 20dB and 12dB of attenuation respectively.

* These items are developments of the Brüel & Kjær Systems Engineering Group and are not standard production items. Please contact your local representative

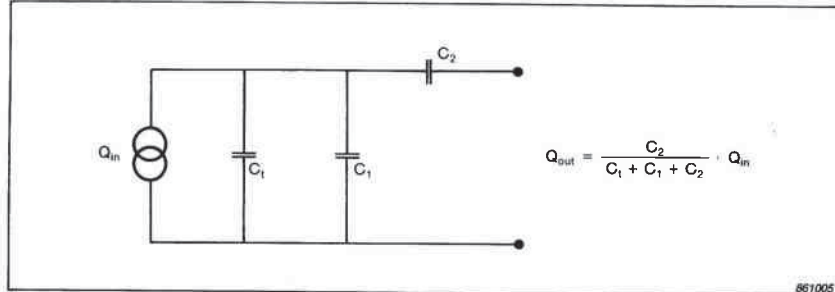

Fig. 3.9. The design of a charge attenuator

3.2.5. Noise in Charge Amplifiers

The use of very long accelerometer cables and low-gain settings will increase the noise of the charge amplifier and hence reduce the signal-to-noise ratio of the measurement.

If the resistive load at the input drops significantly the noise will also increase.

A model of the internal noise sources of an operational amplifier is shown in Fig. 3.10. This model does not include the effects of external noises such as triboelectric effects, groundloop voltages and electromagnetic pick-up in cables. These will be examined in section 3.6.

- Z_t = equivalent impedance of the accelerometer and cable
- Z_f = equivalent impedance in the feedback path
- e_n = noise voltage
- i_n = noise current
- V_o = output voltage

In the high impedance case of the piezoelectric source and mainly capacitive feedback the current noise is negligible. As seen in section 3.2.1 there is a virtual ground and no current flowing at the inverting input of the operational amplifier. Therefore

$$I = \frac{-e_n}{Z_t} = \frac{e_n - V_o}{Z_f}$$

$$V_o = e_n \left(1 + \frac{Z_f}{Z_t} \right)$$

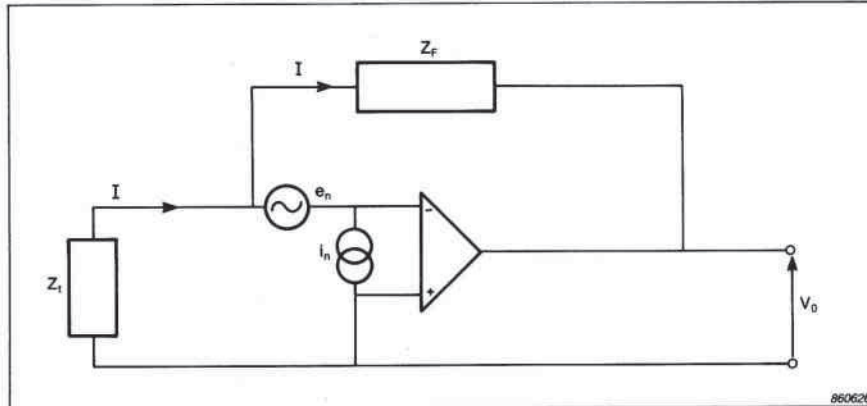

Fig. 3.10. Equivalent circuit for an accelerometer connected to a charge preamplifier. All the noise sources inside the preamplifier have been represented by a voltage source and a current source at the input

To convert this into an expression for the signal at the source it must be divided by the amplification factor, Z_f / Z_t

$$\begin{aligned} e_s &= -V_o \frac{Z_t}{Z_f} \\ &= -e_n \left(1 + \frac{Z_t}{Z_f} \right) \end{aligned}$$

In the mid-frequency range the impedances at both the source and at the output are mainly capacitive so

$$\frac{Z_t}{Z_f} = \frac{C_f}{C_t}$$

where

$$\begin{aligned} C_t &= C_a + C_c + C_p \\ e_s &= -e_n \left(1 + \frac{C_f}{C_t} \right) \end{aligned}$$

Furthermore this can be converted into an equivalent charge noise, q_t on the source capacitance C_t by multiplying it by C_t

$$q_t = e_s \cdot C_t = -e_n (C_t + C_f)$$

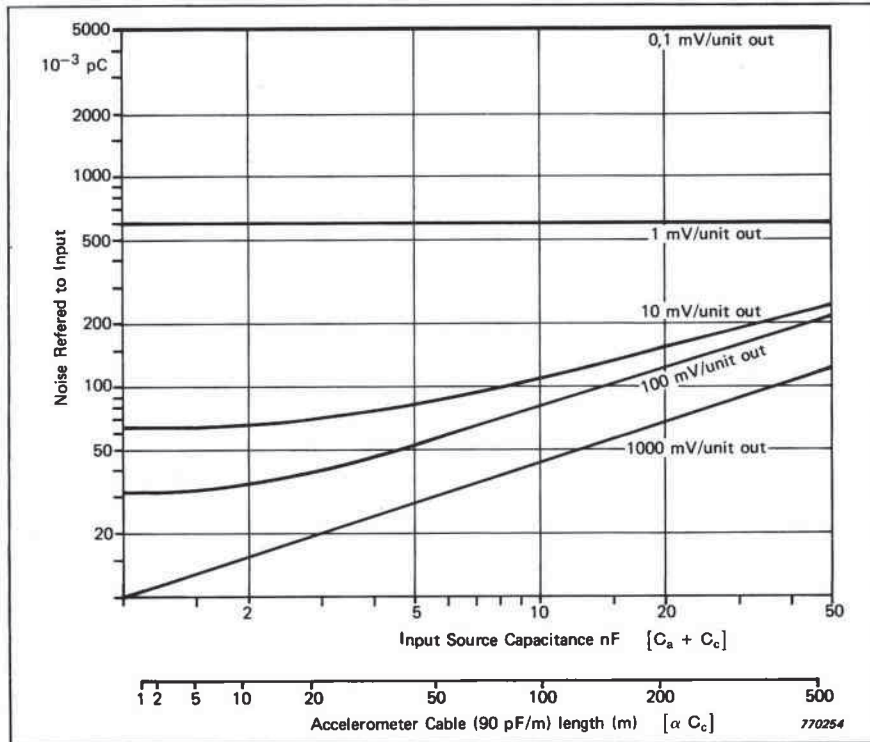

Fig. 3.11. Broadband 2 Hz to 100 kHz noise from a Brüel & Kjær charge amplifier as a function of input source capacitance

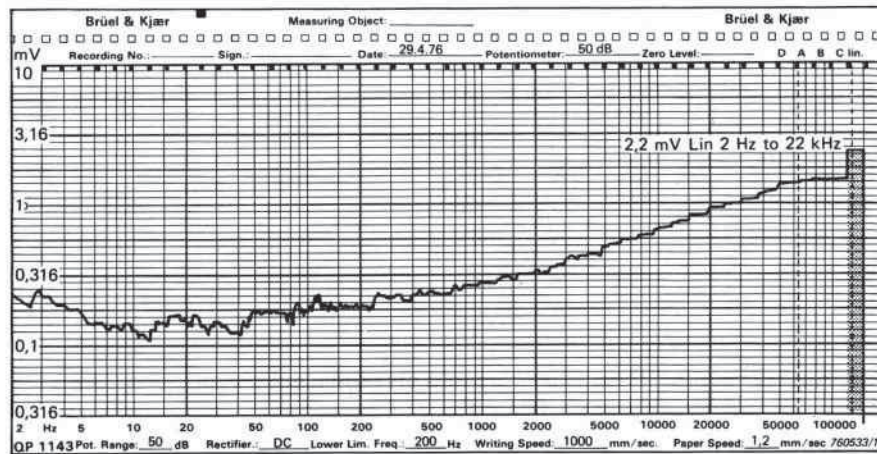

Fig. 3.12. Third octave analysis of the noise produced by a Brüel & Kjær charge amplifier

From this it is seen that although the sensitivity and LLF is not changed significantly by capacitive or resistive loading of the input the charge noise will increase as C_i and C_f increase. Some decrease in signal-to-noise ratio is therefore inevitable when using very long input cables. Fig. 3.11 shows the dependence of the noise level at the input as a function of input capacitance for a particular Brüel & Kjær charge amplifier. Other types exhibit similar dependencies.

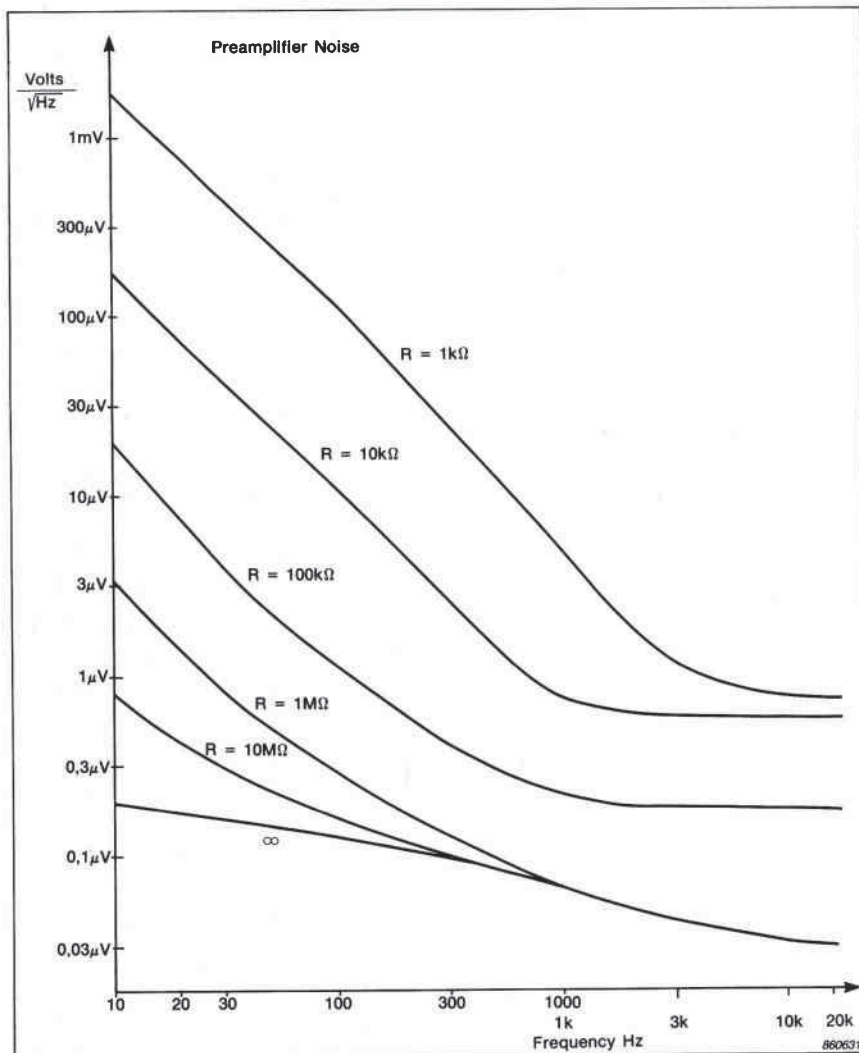

Fig. 3.13. The relationship between input resistance and noise for a charge amplifier

As C_f determines the gain of the preamplifier there will be higher noise at lower gain settings which require a higher feedback capacitance. The use of high gain accelerometers and high gain on the preamplifier will produce better signal-to-noise ratio.

It must be remembered that the cable itself tends to produce noise when exposed to mechanical vibrations. In general therefore, Brüel & Kjær mininoise cables should be used. This is especially true when low level measurements are being made. The cables should be fixed securely. Consult section 4.6.

At low frequencies ($<100\text{Hz}$) the noise from the amplifier will normally increase in inverse proportion to the frequency. This is a property of the operational amplifier and can normally be reduced using a high pass filter. Fig. 3.12 shows a third octave analysis of the noise produced by a Brüel & Kjær charge amplifier.

If the resistive load at the input drops to below $10\text{M}\Omega$ the noise from the charge amplifier will start to increase with the most significant changes at low frequencies. However, any analysis of the sources of this noise requires a detailed knowledge of the input components and their coupling. Fig. 3.13 shows an experimentally derived relationship between the narrowband preamplifier noise and the input resistance. The noise is expressed as volts per square root of filter bandwidth.

3.3. VOLTAGE PREAMPLIFIERS

The output voltage of a voltage preamplifier is proportional to the voltage input and the accelerometer is treated as a voltage source. Changes in the cable capacitance cause a change in the overall sensitivity. Changes in the input resistance can cause a change in the low frequency performance.

A voltage preamplifier detects the vibration induced changing voltage across the accelerometer's capacitance and produces an output voltage proportional to this. Voltage preamplifiers are simpler in their design but suffer operational disadvantages when compared to charge preamplifiers. Because Brüel & Kjær only produce one preamplifier which has the option of a voltage input, the extent of the explanation of the operation is accordingly reduced and outlines are given.

3.3.1. Voltage Sensitivity

Fig. 3.14 shows the equivalent circuit for an accelerometer connected to a voltage preamplifier. By comparing this circuit with that shown in Fig. 3.2 it can be seen that they are identical except for the connection of the operational amplifier. In this case the operational amplifier is connected as a voltage buffer with a gain of 1 ($V_o = V_i$). The very high input impedance is represented by C_p and R_p . The nomenclature is the same as in Fig. 3.2 and Fig. 3.3.

In Fig. 2.8 it was shown that when the accelerometer is not loaded by a cable and preamplifier it produces an output voltage, V_a equivalent to

$$V_a = \frac{Q_a}{C_a}$$

R_a is a very high parallel resistance and can therefore be ignored. From section 3.2.2 the voltage at the preamplifier input can be written directly

$$V_i = \frac{Q_a}{C_a + C_c + C_p}$$

and therefore

$$V_o = V_i = V_a \frac{C_a}{C_a + C_c + C_p}$$

This expression can be expressed in terms of the charge sensitivity S_{qa} [pc/ms^{-2}] and voltage sensitivity S_{va} [mV/ms^{-2}]

$$\begin{aligned} S_{va} &= \frac{S_{qa}}{C_a + C_c + C_p} \\ &= S_{va(\text{open})} \frac{C_a}{C_a + C_c + C_p} \end{aligned}$$

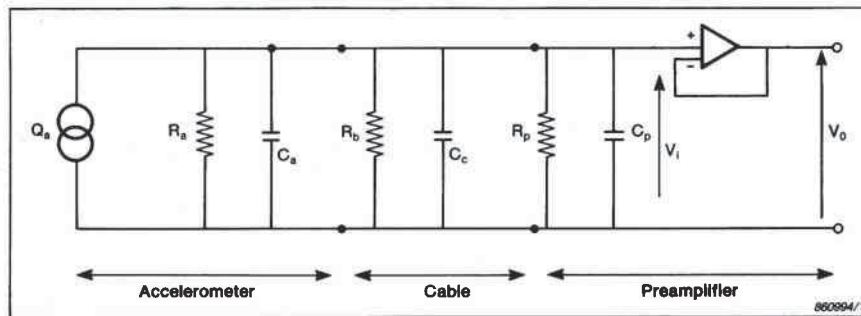

Fig. 3.14. Equivalent circuit of a voltage amplifier using a piezoelectric accelerometer as a voltage source

Where $S_{va(open)}$ is the open circuit (unloaded) accelerometer voltage sensitivity.

Because S_{qa} , the charge sensitivity and C_a are accelerometer constants the voltage sensitivity, S_{va} is dependent on the cable capacitance. This is obviously an undesirable situation because an accelerometer can only be used with the cable with which it was factory calibrated if quoted voltage sensitivities and voltage preamplifiers are used. If the cable is changed then a recalibration is required. A short example will help to illustrate this.

Example. While taking a vibration measurement a requirement has arisen for a longer, stronger cable. The existing cable is a standard Brüel & Kjær 1,2 m cable AO 0038 and a suitable replacement is the 3 m reinforced cable AO 0122. Calculate the new voltage sensitivity for this combination:

Typical capacitance of cable AO 0038 = 110 pF
 Capacitance of accelerometer (including cable) = 1117 pF
 Charge sensitivity = 9,8 pC/ms⁻²
 Voltage sensitivity = 8,76 mV/ms⁻²

From this the capacitance of the piezoelectric element alone C_a can be calculated

$$C_a = 1007 \text{ pF}$$

The typical capacitance of accessories cable AO 0122, C_c is 260 pF. Hence the new voltage sensitivity is easily calculated

$$S_v = \frac{9,8 \cdot 10^{-12}}{(1007 \cdot 10^{-12}) + (260 \cdot 10^{-12})}$$

$$= 7,73 \text{ mV/ms}^{-2}$$

The voltage sensitivity has dropped 11% simply by changing the cable.

This dependence of sensitivity on input capacitance is not only extremely inconvenient when different cables are used but it also means that the signal-to-noise ratio is reduced with longer cables. With extremely long cables only a small fraction of the unloaded voltage will be present at the input of the amplifier.

3.3.2. Lower Limiting Frequency

The treatment of low frequency performance given in section 3.2.2 can be used again to show that the Lower Limiting Frequency (-3dB point) is expressed by

$$f_l = \frac{1}{2\pi R_t C_t}$$

where

$$C_t = C_a + C_c + C_p$$

$$\frac{1}{R_t} = \frac{1}{R_a} + \frac{1}{R_b} + \frac{1}{R_p}$$

To ensure that the LLF is low enough to provide useful operation at frequencies down to 1 Hz or less the RC product must be very large. Theoretically there are two ways of doing this;

1. Make the total capacitance as large as possible. As C_a is an accelerometer constant then C_c must be increased by adding more cable. This is not a practical solution as this will result in a decrease in the voltage sensitivity and a loss in dynamic range.
2. Design a preamplifier with a high input resistance. This is the approach taken with voltage preamplifiers. However, if the input resistance is reduced for any reason then the LLF will increase. This can happen if moisture penetrates the output connector of an accelerometer. The leakage resistance is lowered and this shunt resistance across the input lowers the input resistance.

3.3.3. Noise in Voltage Preamplifiers

Unlike the noise produced by a charge preamplifier, the noise produced by a voltage preamplifier is independent of input capacitance and hence the gain setting and cable length do not change the noise at the input. However this is not a real advantage as the signal-to-noise level worsens as the voltage sensitivity decreases with increasing cable length.

3.4. PREAMPLIFIER OUTPUT CABLES

In the case of both charge and voltage amplifiers it is important that they are capable of providing sufficient output current to drive a measuring instrument. The voltage necessary to produce this drive current is derived at the output of the operational amplifier and is developed across the impedance of the cable.

When high capacitance loading is present at the output of the preamplifier a limitation to the maximum output voltage swing can occur. This will only cause a problem when very long cables and high frequency performance are required. For example, at 10 kHz this limitation will arise when the load exceeds 20 nF (corresponding to 200 m of 100 pF/m cable) for the preamplifier shown below.

In some cases the limitation is directly caused by a maximum output capability on the preamplifier. If the maximum output current is 8 mA (typical) and the load is 20 nF then an impedance of approximately 796 Ω at 10 kHz is obtained and a peak voltage of 6,37 V results. Therefore if the combination of vibration level, accelerometer sensitivity and preamplifier sensitivity should produce a larger output than this, attenuation occurs. The effect of output cable capacitance on the high frequency response of a Brüel&Kjær charge amplifier is shown in Fig. 3.15.

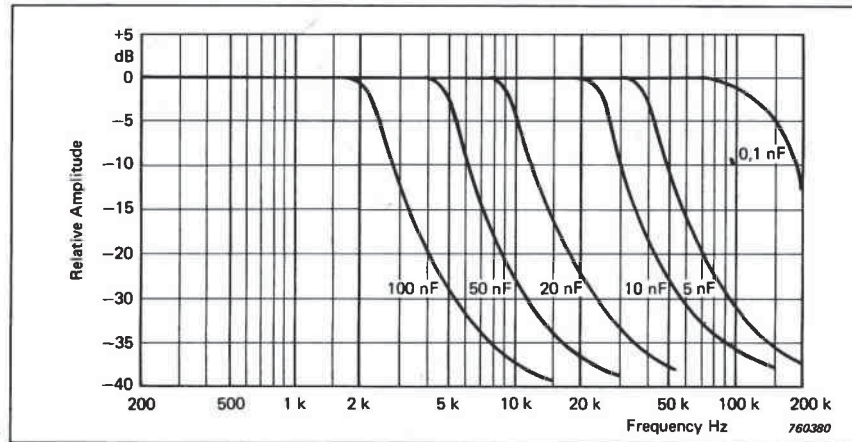

Fig. 3.15. Typical influence of output load capacitance on the high frequency response of a Brüel&Kjær Charge Preamplifier

3.5 LINE-DRIVE SYSTEMS

A line-drive amplifier is essentially the “front-end” of a charge or voltage amplifier which can be built into an accelerometer. The range of Brüel&Kjær line-drive accelerometers can be seen in Fig. 3.16. A separate line-drive amplifier can also be attached directly to a conventional accelerometer or placed a short distance from it. Remote usage of the Type 2644 has the advantage that higher levels of vibration can be measured, and at higher temperatures, compared to the line-drive accelerometer built into or mounted on the accelerometer. The Brüel&Kjær Line-drive Amplifier Type 2644 can be seen in Fig. 3.17.

The power for a line-drive system must be derived from an external line-drive power supply. For driving the Brüel&Kjær line-drive accelerometers and pre-amplifier the Line-drive Supply Type 2813 is used. This is a battery powered instrument with the capability of powering up to two line-drive accelerometers simultaneously. The Type 2813 can be seen in Fig. 3.18. The voltage output of

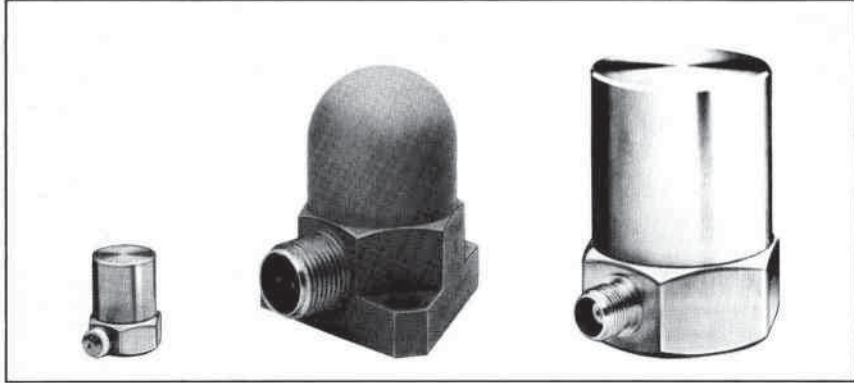

Fig. 3.16. Brüel & Kjær Line-drive accelerometers. (From left to right) Types 4390, 8317 and 8318. The photographs are scaled 1:1, 1:1, and 1:2 respectively



Fig. 3.17. Attaching the Line-drive Amplifier Type 2644 to the top of an accelerometer

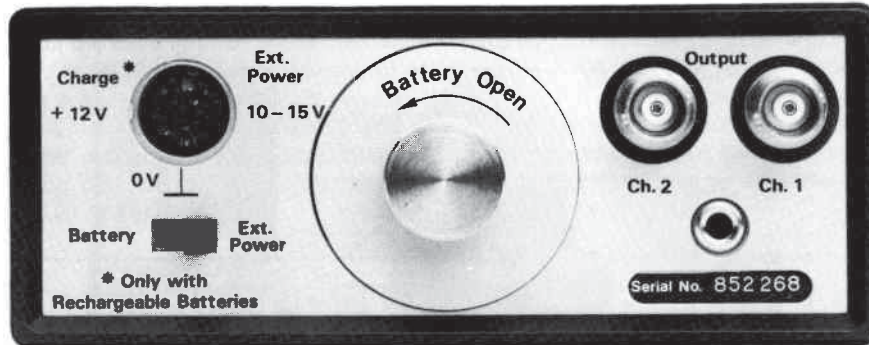

Fig. 3.18. 2 channel Line-drive supply Type 2813

the Type 2813 is used as an input into measurement and analysis equipment. A similar line-drive supply is also built into several Brüel & Kjær vibration and signal analyzers.

The practice of building the preamplifier into an accelerometer is by no means recent. The first such systems were designed with the objective of improving the performance of very low capacitance and low sensitivity accelerometers which used quartz as the piezoelectric element. Such accelerometers were very sensitive to noise generated by the cable (triboelectric noise) and noise picked up by the cable (electromagnetic noise).

Although modern accelerometers using piezoelectric ceramics and low-noise transducer cables can solve most of the earlier problems, it can still be advantageous to use built-in preamplifiers, or line-drive preamplifiers mounted close to the accelerometer in potentially "noisy" environments. Consequently line-drive preamplifiers are often used in industrial measurements. Here they have the advantage of driving low impedance signals along extraordinarily long and inexpensive cables. The sensitivity of such a system to a combination of ground loop voltages and cable noise is lower compared to any other configuration of vibration preamplifier. This will be shown in section 3.6.

Some line-drive designs have suffered poor performance due to the inadequacies of the built-in electronic circuitry. However with the advances in thick-film circuit techniques employed at Brüel & Kjær, high quality and high performance preamplifiers are built in to Brüel & Kjær accelerometers.

The addition of electronics into an accelerometer does however restrict the temperature and dynamic range of the accelerometer into which they are built. This also applies to line-drive preamplifiers mounted onto an accelerometer. The added mass of this preamplifier must also be considered when making measurements on light panels or similar structures.

Different line-drive designs have been used but today almost all systems use a two-conductor cable which links the preamplifier to the power supply and carries both the power and the vibration signal. The power supply is either a constant current or constant voltage source. The two systems are *not* interchangeable. The Brüel & Kjær line-drive system uses a constant voltage source and power supply current modulation is used to transmit the vibration signal. This system will be shown to perform better than the constant current source system.

3.5.1. Brüel & Kjær Line-drive Accelerometer and Line-drive Supply

The sensitivity of a line-drive accelerometer is expressed in terms of the current sensitivity ($\mu\text{A}/\text{ms}^{-2}$) at the output of its built-in line-drive amplifier. The final sensitivity at the output of the power supply is simply obtained by multiplying this sensitivity by the power supply sensitivity ($\text{mV}/\mu\text{A}$) to obtain mV/ms^{-2}

For example, a line-drive accelerometer with a sensitivity of $3,16 \mu\text{A}/\text{ms}^{-2}$ connected to a Line-drive Supply Type 2813 gives an overall sensitivity of $3,16 \text{mV}/\text{ms}^{-2}$.

3.5.2. Brüel & Kjær Line-drive Amplifier and Line-drive Supply

The charge sensitivity of the accelerometer (pC/ms^{-2}) is first converted into a current sensitivity ($\mu\text{A}/\text{ms}^{-2}$) at the output of the Type 2644 via the sensitivity of the 2644 ($\mu\text{A}/\text{pC}$). Then the process continues as in the last section by multiplying the output of the Type 2644 by the power supply sensitivity to obtain mV/ms^{-2} .

For example, an accelerometer of sensitivity $3,16 \text{pC}/\text{ms}^{-2}$ when used with a Type 2644 and 2813 gives the same sensitivity as in the last example, i.e. $3,16 \text{mV}/\text{ms}^{-2}$.

3.6. COMPARISON OF THE SENSITIVITY OF DIFFERENT VIBRATION PREAMPLIFIER SYSTEMS TO EXTERNAL NOISE SOURCES

In multichannel measurement set-ups where ground loops and long cables are often a problem, it is important to know the comparative sensitivity of the measurement system to external noise and to select the best system for that environment.

The following systems will be compared.

1. Normal grounded (i.e non-insulated) accelerometer with a charge preamplifier.

2. Grounded accelerometer using a charge amplifier with a "floating" input.
3. Brüel & Kjær line-drive system using constant voltage supply and current modulation.
4. Brüel & Kjær line-drive system using constant voltage supply, current modulation and a "floating" input.
5. Voltage line-drive system using constant current diode supply (not supplied by Brüel & Kjær).
6. Balanced accelerometer using a differential charge preamplifier.

In addition to these systems the benefit of using an insulated mounting technique (i.e. mica washer) or an accelerometer with an electrically insulated base will be examined.

In the following analysis the noise at the input is assumed to be caused by a combination of two effects.

1. **Triboelectric Effect.** All coaxial cables will generate a charge if their mechanical movement is not restricted. For the purpose of comparing the results in the analysis, this effect will give rise to a charge noise q_n of 100 pC in the cable in each of the cases below. The triboelectric effect can be modelled as a perfect charge source in the analysis. This phenomenon will become more apparent if the cable is not clamped down onto the vibrating surface and low noise cables are not used.

Note: A triboelectric charge of 100 pC is an extreme case and is only used here as a means of comparison between the systems.

2. **Ground-loops.** In large machines there is always the possibility that the machinery housing may not be at earth potential. Consequently the accelerometer case and cable screen will not be at earth potential and a voltage drop will exist along the cable. For the purpose of comparing the results obtained in the analysis, this voltage, e_n will be assumed to be 1 V.

In addition to these two phenomena electromagnetic interference (EMI) might contribute to the system noise. The mixing of power circuits with systems carrying small signals and with high impedances can be an example of the inadequate treatment of EMI. Another typical situation is power lines running alongside signal lines over long distances. The resulting noise signals can be divided into capacitively-coupled and inductively-coupled signals. If a small capacitance to the ground line exists from a high voltage system, this will give a direct input signal. Line-drive systems are less sensitive to this kind of EMI than charge systems at the normal power line frequencies.

Inductive coupling is often possible whenever accelerometer cables are near to cables carrying high AC-currents. The coupling increases as the frequency increases. Current “spikes” from fast switching-circuits and other high frequency currents are common causes of electromagnetic interference. Magnetic shielding can be used to minimize its effects. Twisted-pair cables are more insensitive to this effect because the total flux is close to zero. In practice, coaxial cables give adequate protection.

Noise from electromagnetic interference is normally not of comparable magnitude to the noise from ground-loops. Typical coupling parameters are difficult to define. Consequently, it is only ground-loop and triboelectric noise that we will consider in the cases which follow.

Accelerometer + Preamplifier Description	Relative Sensitivity to external noise (dB)		Relative Sensitivity to external noise with the addition of an insulated base on the accelerometer (dB)	
	Ground loop noise	Triboelectric noise	Ground loop noise	Triboelectric noise
Normal accelerometer grounded input charge amplifier	0 (ref. 1000 pC/V)	0 (ref. 100 pC)	-130	0
Normal accelerometer “floating” input charge amplifier	-70	0	-80	0
Brüel & Kjær line-drive accelerometer Brüel & Kjær line-drive power supply	-26	-80	-154	-80
Brüel & Kjær line-drive accelerometer “floating” input Brüel & Kjær Line-drive power supply	-70	-80	-134	-80
Line-drive accelerometer constant current line-drive supply – (non-Brüel & Kjær)	0	-80	-130	-80
Balanced accelerometer Differential Charge Amplifier	-60	0	-60	0

T01158GB1

Table 3.1. Comparison of the immunity of several accelerometer/preamplifier systems to external noise

In all cases the noise is referred to the input of the final instrument in the chain in the appropriate units (i.e. equivalent charge for a charge preamplifier, equivalent current for a constant voltage line-drive power supply and equivalent voltage for a constant current line-drive supply). These values can then be converted into an overall noise sensitivity by multiplying by the sensitivity of the final instrument.

The results of the following analysis are first presented here in tabular form to simplify comparison of these systems. The sensitivities are expressed in decibels relative to the case of a non-insulated accelerometer connected to an ordinary charge preamplifier. Consequently a negative sign indicates a less sensitive system offering greater immunity to external noise. See Table 3.1.

Two reference levels are given in the table. One is for ground loop noise sensitivity and the other one is for triboelectric noise sensitivity. Sensitivity comparisons are only calculated between noise sources of the same origin. The reference levels are given in the table.

3.6.1. Grounded Accelerometer and Charge Preamplifier

Fig. 3.19. shows an equivalent circuit for this set-up in which the charge and voltage noise sources have been introduced. By using the basic relationships between charge, voltage and capacitance, Ohms Law and the assumptions of noise levels from the last section, it is a relatively simple matter to express the equivalent charge noise at the input to the preamplifier. Each noise source is considered independently.

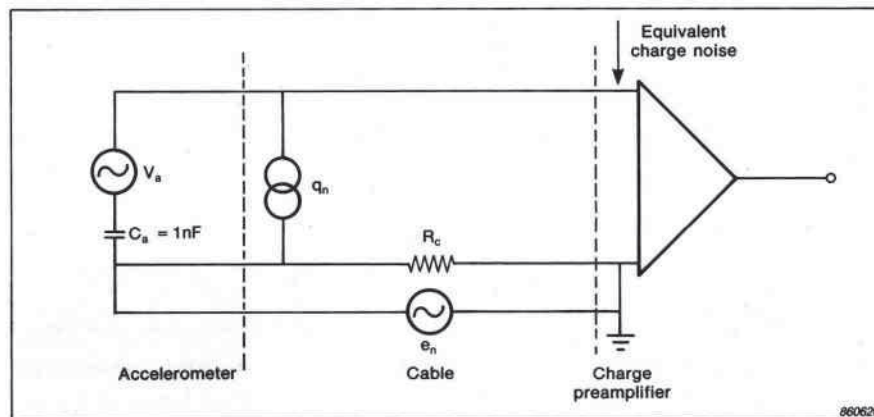

Fig. 3.19. Simplified equivalent circuit of normal grounded accelerometer connected to a normal grounded input charge amplifier

Ground Loop Noise

This is simply the product of the noise voltage and the accelerometer capacitance ($C_a = 1 \text{ nF}$), i.e. 1000 pC/V .

Triboelectric Noise

This has been defined as 100 pC for the sake of comparison with other examples.

The noise due to the ground loop is much larger than the noise due to the triboelectric noise.

3.6.2. Grounded Accelerometer with Charge Amplifier (“Floating” Input)

The Type 2651 Charge Amplifier has the option of a so-called “floating” input as opposed to the “grounded” input in the last example. A “grounded” input of this kind is used on all Brüel & Kjær preamplifiers. The analysis becomes a little more complicated as a second operational amplifier is switched in to the input circuitry of the preamplifier. The equivalent circuit of this set-up is shown in Fig. 3.20.

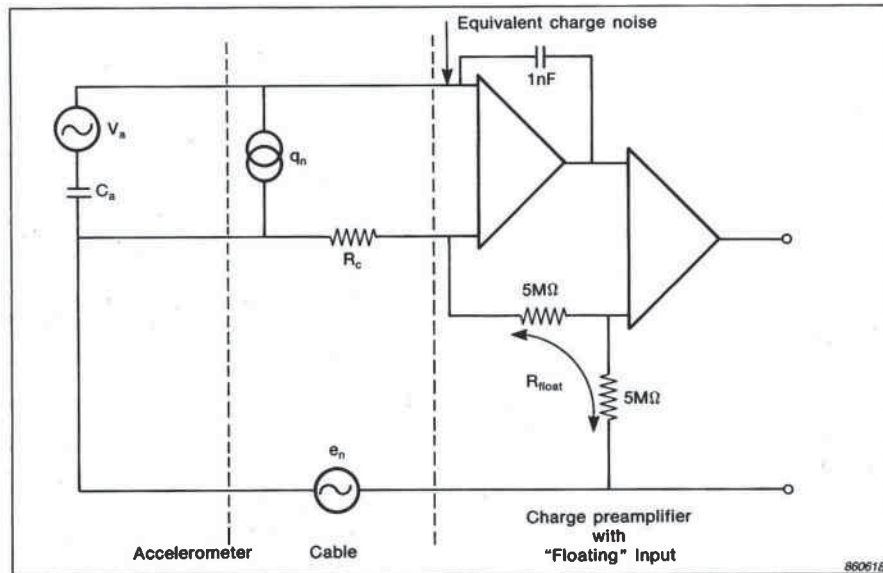

Fig. 3.20. Simplified equivalent circuit of normal grounded accelerometer connected to a charge amplifier with a “floating” input

Ground Loop Noise

The calculation of the ground loop noise involves the use of the Common Mode Rejection Ratio (CMRR) of the second operational amplifier. In this case the CMRR is approximately 70 dB (a factor of $0,3 \cdot 10^{-3}$). The noise from the cable is voltage divided between the cable's series resistance R_c and the combined high resistance to earth, R_{float} , before the second amplifier. Nearly all of this voltage falls across R_{float} . A typical value for R_c is $0,05 \Omega/m$. The equivalent charge corresponding to the output of the "floating" amplifier is found by dividing by 1 mV/pC , which is the charge amplifier sensitivity.

The equivalent charge noise at the input now becomes

$$C_a \frac{R_c}{R_{float} + R_c} \cdot e_n + \frac{CMRR}{1 \text{ mV/pC}} \cdot \frac{R_{float}}{R_{float} + R_c} e_n$$

Substituting the relevant values into this equation and assuming there is 200m of cable then the ground loop noise sensitivity becomes $0,301 \text{ pC/V}$.

Triboelectric Noise

This is unaffected by the second operational amplifier and therefore it remains 100 pC at the input.

In this case it has been seen that using a "floating" input effectively eliminates the effects of the noise due to ground loops. Triboelectric noise is the more important consideration.

3.6.3. Brüel & Kjær Line-drive Amplifier and Power Supply (Grounded Input)

Fig. 3.21 shows an equivalent circuit for a line-drive amplifier or accelerometer connected to a line-drive supply such as the Type 2813 or a Brüel & Kjær Analyzer. The equivalent current noise at the input to the power supply must be expressed. The sensitivity of the line-drive amplifier is fixed at $1 \mu\text{A/pC}$. The output impedance of the line-drive amplifier is set at $20 \text{ k}\Omega$.

Ground Loop Noise

$$Q = \frac{e_n}{R_o \cdot 10^{-6} [A/pC]}$$

The division by $[A/pC]$ simply converts this value from an equivalent current noise at the input of the power supply to an equivalent charge noise at the input of the line-drive amplifier. This results in an equivalent noise sensitivity of 50 pC/V .

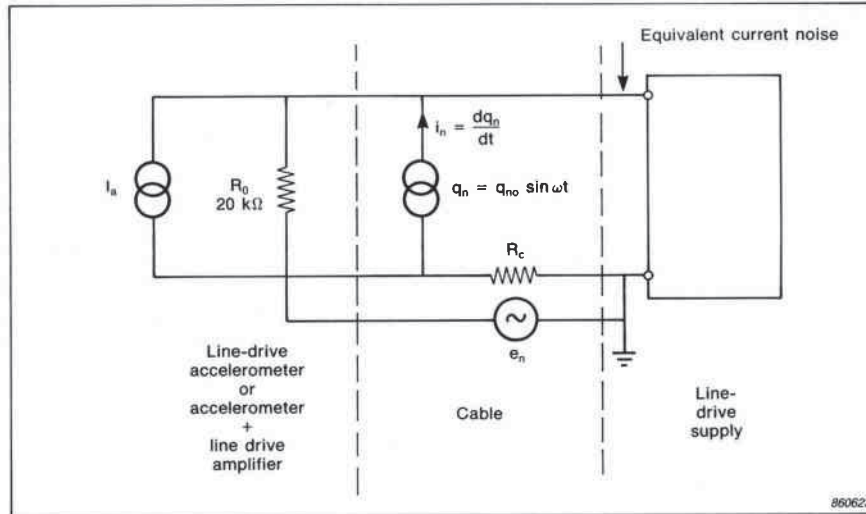

Fig. 3.21. Simplified equivalent circuit of grounded Brüel & Kjær line-drive accelerometer connected to Brüel & Kjær line-drive supply

Triboelectric Noise

The current i flowing due to the triboelectric effect may be assumed to be an harmonically varying quantity if it is derived from low frequency harmonic mechanical excitation of the cable. The noise current input into the power supply is then expressed by

$$i_n = \frac{dq_n}{dt} = \omega q_{no} \cos \omega t$$

When the sensitivity of the power supply is taken into account this gives a triboelectric noise sensitivity of 10^{-2} pC at 16 Hz ($\omega = 100$) which increases with frequency. In order to have the same triboelectric noise sensitivity as the normal charge amplifier of section 3.6.1 the excitation frequency of the cable would have to be 160 kHz. Consequently the line-drive system offers a vast improvement on triboelectric noise performance when compared to a normal charge amplifier.

It can also be seen that the noise originating from ground loop interference is many thousand times greater than that originating from triboelectric effects. The line-drive system shows a greater immunity to overall noise when compared to the ordinary charge amplifier. Even in the case of the "floating" charge amplifier the immunity of the line-drive system to overall noise is still superior if high triboelectric noise is present.

3.6.4. Brüel & Kjær Line-drive Amplifier and Power Supply (“Floating” Input)

It is possible to “float” the input of the line-drive supply in a similar way to the charge amplifier in section 3.6.2. This facility is available on the Type 2813. The equivalent circuit is shown in Fig. 3.22. This is the same as in the last case except that an equivalent floating resistance R_{float} ($\approx 20\text{ k}\Omega$) exists. This is produced by an operational amplifier in the Type 2813. The ground loop voltage is again divided between R_c and R_{float} . The Type 2813 has a *CMRR* of 70 dB and the cable is assumed to be 200 m long.

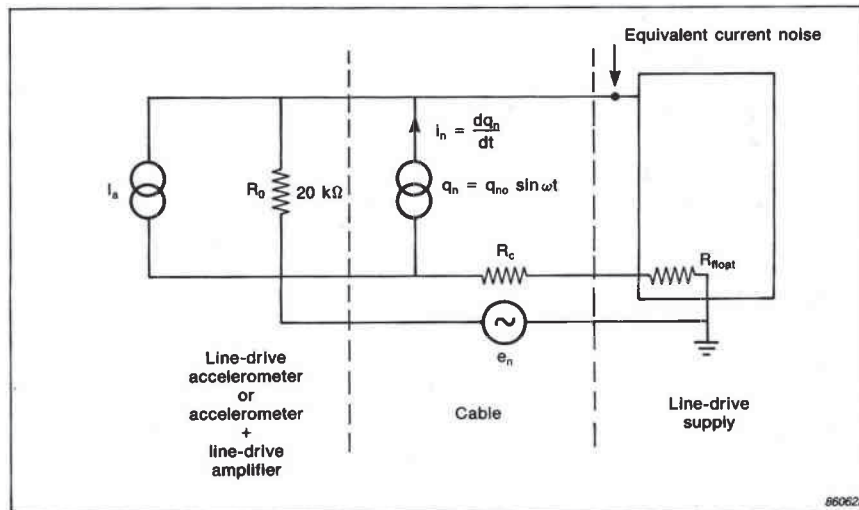

Fig. 3.22. Simplified equivalent circuit of grounded Brüel & Kjær line-drive accelerometer connected to a Brüel & Kjær line-drive supply with a “floating” input

Ground Loop Noise

$$q_n = \frac{e_n \frac{R_c}{R_{float}}}{R_o [\Omega] 10^{-6} [A/pC]} + \frac{e_n [V]}{CMRR 1 [mV/pC]}$$

This gives a sensitivity to ground loop voltages of only 0,325 pC/V which is comparable to the normal charge amplifier using a “floating” input.

Triboelectric Noise

The addition of a floating input condition will not change the sensitivity to triboelectric noise and the same results are obtained as in the last section.

3.6.5. Line-drive System Based on Constant Current Power Supply

This system is not used by Brüel & Kjær. The power supply is simpler than the constant-voltage current-modulation supply used in the Type 2813. It should be stressed that cable noise can be induced by electromagnetic fields. This is especially true if cheap two conductor cables are used. It will now be seen that a line-drive system based on a constant-current power supply is not as immune to cable noise as the Brüel & Kjær system. Regardless of the type of line-drive system used it is recommended to use coaxial cables when severe electromagnetic fields are present. These points are important because the main benefit of line-drive accelerometers should be the suppression of the effects of electromagnetic fields and the possibility of using cheap two-conductor cables.

An equivalent diagram for a constant current system is shown in Fig. 3.23.

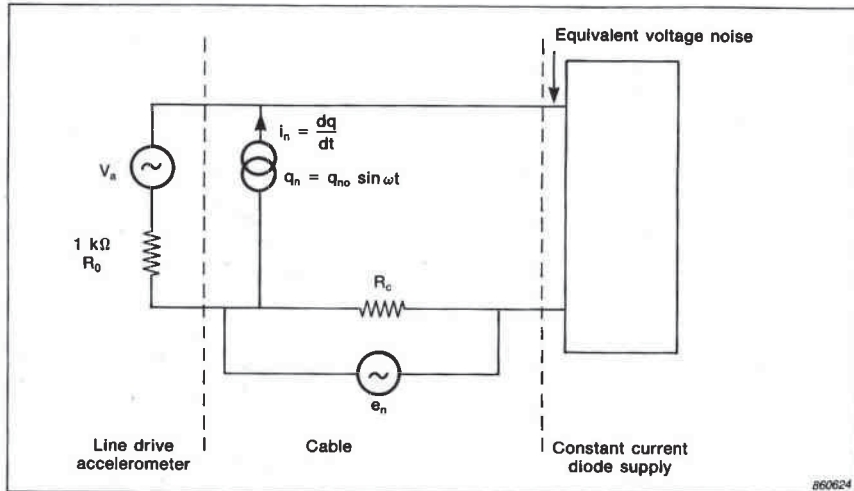

Fig. 3.23. Simplified equivalent circuit of a line-drive system based on a constant current power supply

Ground Loop Noise

The ground loop voltage is fully developed across the input to the power supply. If the line-drive amplifier has a sensitivity of 1 mV/pC then the noise sensitivity is 1000 pC/V. This is not as good as the Brüel & Kjær line-drive design and offers no improvement on the conventional charge amplifier.

Triboelectric Charge Noise

$$q_n = \frac{i_n R_0}{1 [mV/pC]}$$

$$= \frac{R_o \omega q_{no} \cos \omega t}{1 [mV/pC]}$$

At an excitation of 16Hz the triboelectric charge noise is approximately 10^{-2} pC which is the same as the Brüel & Kjær line-drive design.

3.6.6. Balanced Accelerometer and Differential Charge Amplifier

In a balanced accelerometer the piezoelectric elements are insulated from the housing. The equivalent circuit diagram is shown in Fig. 3.24. A capacitance C_n exists between each charge pick-up point and the accelerometer housing. There will be an unbalance in these capacitances under operating conditions and this is represented by ΔC_n .

The capacitance between the outer screen and the two inner screens is represented by C_s and is shown equally divided between both inner capacitances.

The capacitance of the dielectric surrounding the two conductors is represented by C_d and the unbalance represented by ΔC_d .

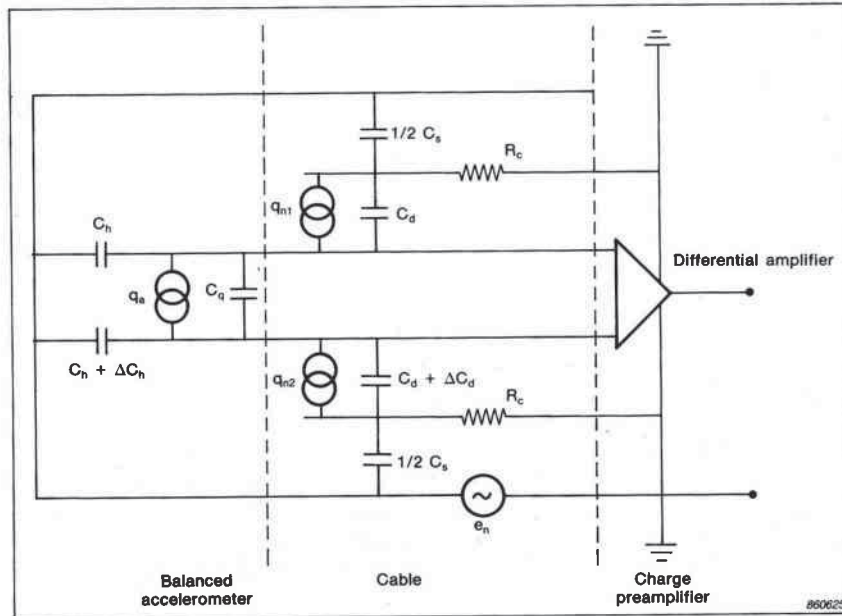

Fig. 3.24. Simplified equivalent circuit of a balanced accelerometer connected to a differential charge amplifier

The triboelectric charges, q_{n1} and q_{n2} are uncorrelated sources and will not balance out.

With an unbalance of 1 pF between the pick-up points on the piezoelectric elements inside the accelerometer $\Delta C_n = 1$ pF, the equivalent charge noise is 1 pC/V.

Due to the large impedance ratio at 50 Hz between C_s and R_c , the unbalance of the cable is about 10^8 times smaller than the transducer unbalance and can be ignored.

The uncorrelated triboelectric charges still introduce the same amount of charge noise at the input to the charge amplifier as the normal accelerometer and charge preamplifier combination.

3.6.7. Effect of Insulated Mounting of the Accelerometer on Noise.

An accelerometer can be electrically insulated from the surface onto which it is mounted (see section 4.4). This is achieved either by using a mica washer under the accelerometer or using an accelerometer which has been made with an insulated base. Improvements on ground loop noise can be obtained in all cases except the balanced accelerometer and the normal charge amplifier with a "floating" input. No improvement is obtainable in these two cases.

Obviously the triboelectric noise generated by the cable is independent of the insulated mounting of the accelerometer and the sensitivity to triboelectric noise remains unchanged. Without going through the complex circuit analysis the noise sensitivities shown in Table 3.2 can be obtained.

Insulated Accelerometer and Preamplifier Description	Ground loop noise Sensitivity pC/V
Normal accelerometer and charge preamplifier	$0,3 \times 10^{-3}$
Brüel & Kjær line-drive accelerometer and supply (grounded input)	$0,02 \times 10^{-3}$
Brüel & Kjær line-drive accelerometer and supply ("floating" input)	$0,2 \times 10^{-3}$
Line-drive system based on constant current supply	$0,3 \times 10^{-3}$

T01163GB1

Table 3.2. Comparison of sensitivities of several accelerometer/preamplifier systems to ground loop noise when the accelerometer is insulated from the structure

3.7. SPECIAL PREAMPLIFIER FEATURES

Some of the following facilities are available on Brüel & Kjær Charge Amplifiers and vibration measurement equipment fitted with preamplifier inputs. The arrangement of these features within a Brüel & Kjær preamplifier can be seen in Fig. 3.25. For more details on the different types consult Appendix E for condensed specification tables.

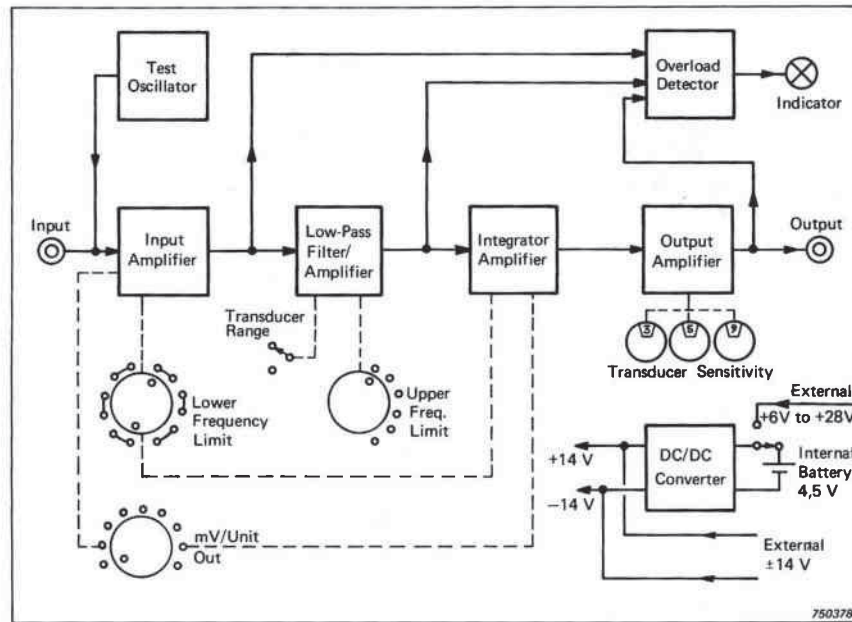

Fig. 3.25. Block diagram showing the arrangement inside a Brüel & Kjær charge amplifier

3.7.1 Integration Networks

The integration of acceleration signals to give velocity and displacement data is one of the distinct advantages of using accelerometers as the transducer in any vibration measurement. The choice of measurement parameter was discussed in Chapter 1 and now the integration of these signals will be examined.

For harmonic signals, relationships exist between the parameters acceleration, velocity and displacement. Their integration is a simple matter of dividing by a factor proportional to the frequency.

Let the acceleration signal be represented by a sine wave expressed by

$$a = a_0 \sin \omega t$$

where

$$\begin{aligned} a &= \text{acceleration at time } t \\ a_0 &= \text{acceleration amplitude} \\ \omega &= \text{frequency in radians per second.} \end{aligned}$$

The first integration will yield velocity v

$$\begin{aligned} v &= \int a \, dt \\ &= \frac{-a_0}{\omega} \cos \omega t \\ &= v_0 \cos \omega t \end{aligned}$$

where

$$v_0 = \frac{-a_0}{\omega}$$

It can be seen that the constant of integration has been taken as zero. This is not true when transient signals are integrated.

The second integration yields the displacement signal, x

$$\begin{aligned} x &= \int v \, dt \\ &= \frac{-a_0}{\omega^2} \sin \omega t \\ &= x_0 \sin \omega t \end{aligned}$$

where

$$x_0 = \frac{-a_0}{\omega^2}$$

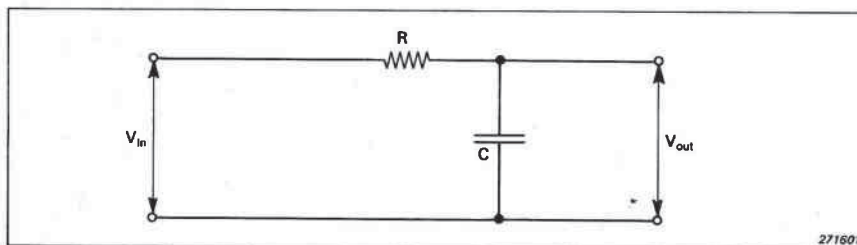

Fig. 3.26. A simple RC integration network

This simple analysis has demonstrated that integration is achieved by dividing the acceleration by a factor proportional to the frequency to obtain velocity, and by a factor proportional to the square of the frequency to obtain displacement.

Electronic integration, at its most basic level can be achieved using a electronic network similar to that shown in Fig 3.26.

When the voltage V_{in} from the accelerometer and preamplifier is applied to the input, the voltage across the capacitor V_{out} can be shown to be

$$V_{out} = \frac{V_{in}}{1 + j\omega RC}$$

when $\omega RC \gg 1$ then

$$V_{out} \approx \frac{1}{jRC} \frac{V_{in}}{\omega}$$

By comparing this expression with the previous integration analysis it can be seen that an electronic integration has taken place. The factor $1/RC$ can be taken care of in the internal calibration. A double integration is achieved by using a second integration network to yield displacement information.

If the absolute value of the last expression is plotted against frequency then a response similar to Fig. 3.27 is obtained. It can be seen that a low frequency

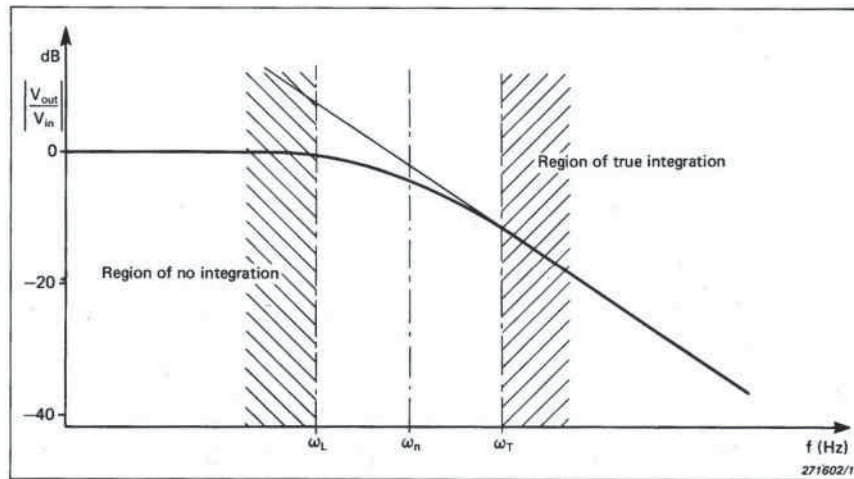

Fig. 3.27. The quality of the integrated signal as a function of frequency

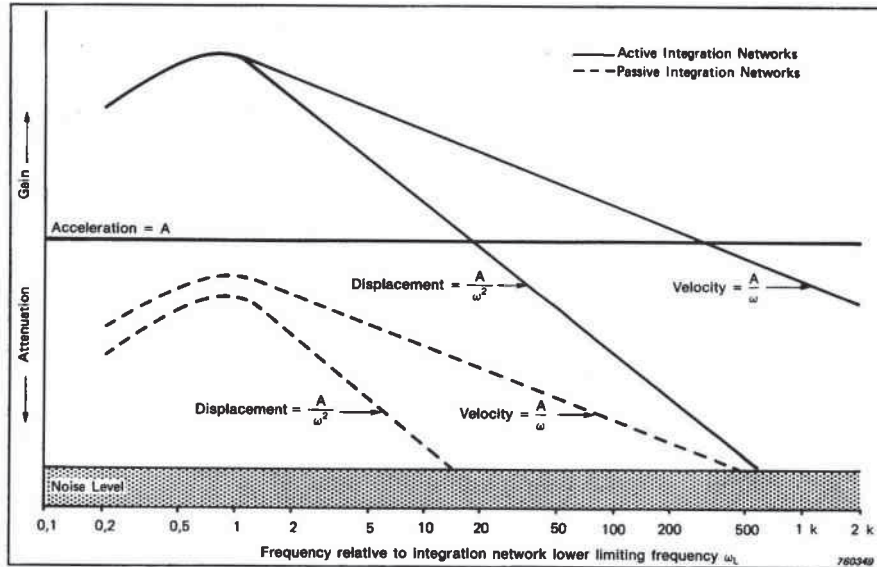

Fig. 3.28. Frequency response characteristics of an electronic integrator

limit ω_L exists below which no true integration takes place. Between ω_L and ω_T only partial integration takes place. Only signals with frequencies greater than ω_T are truly integrated.

The integration range of the filter is extended by amplifying the signal before it is applied to the integrator. This also improves the dynamic range of the integrator. An integrator of this kind is termed "active" and may be found in the Brüel & Kjær preamplifiers which have integration options. The typical response of an integrator can be seen in Fig. 3.28. Notice the existence of a peak in the filter.

Integration networks must be used with caution when measuring transient vibration signals. The low frequency content of a transient may excite the peak of the filter and cause the integration network to "ring" and distort the measurement. In addition the phase response of the integrator will cause transient distortion. Fig. 3.29 shows the effect of electronic integration on two sinusoidal acceleration transients of 1 and 10ms duration. The electronic integration is compared to the true integration. The low frequency content of the longer transient causes errors in the measurement of the peak values.

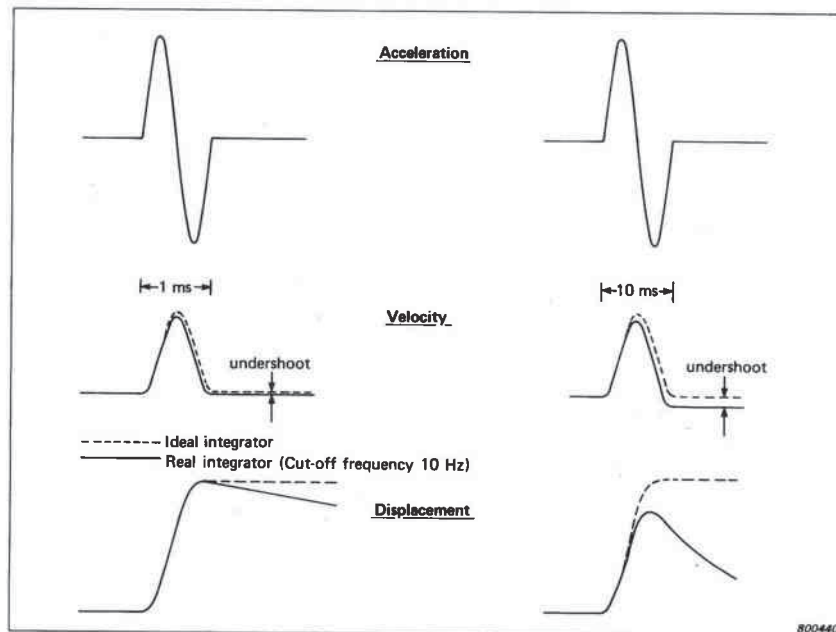

Fig. 3.29. Comparison between electronic and theoretical integration of two acceleration pulses

3.7.2. Filters

It is often desirable to limit the frequency range in a vibration measurement. For example, when making vibration measurements on rotating machinery containing gears, frequency components above the band of interest can have appreciably higher levels than the vibrations of interest. If these high frequencies are not filtered out at this stage they will be clipped by amplifier overloads and create difference frequencies lying in the desired frequency band where they are no longer separable from the required signal components. Filtering of a vibration signal can optimize the dynamic range of the instrumentation as described in section 1.4.

A high pass filter can be used to remove the spurious low frequency noise resulting from non-vibrational inputs such as temperature transients and base bending. In general these are only a problem when accelerometers other than the Delta Shear[®] type are used.

Several Brüel & Kjær preamplifiers are equipped with active low and high pass filters whose -3 dB points are selectable. For details on the various types consult Appendices E and F.

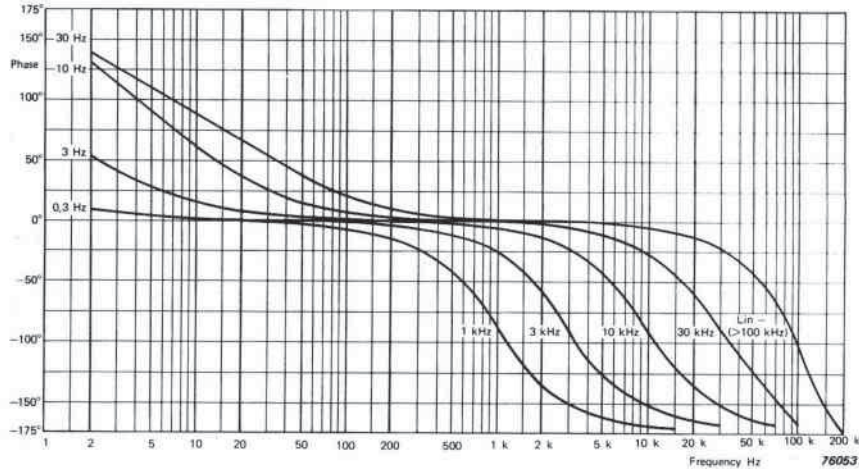

Fig. 3.30. Phase characteristics of a Brüel & Kjær charge amplifier for different filter settings

As far as the measurement of periodic signals is concerned, phase non-linearities associated with filters will have no influence on their RMS values although phase must be taken into account when measuring transients. If the frequency content of the signal is known it is possible to select the frequency range which introduces the minimum amount of phase distortion. This can be achieved by referring to a diagram similar to that in Fig.3.30 which is taken directly from the Instruction Manual of a charge amplifier.

When two charge amplifiers are used together as in mechanical impedance measurements or in calibration the maximum phase difference, $\Delta\phi$, can be determined from the following relationship:

$$\Delta\phi = \tan^{-1} \frac{\frac{f_{c1}}{f_{cn}} - \frac{f_{c2}}{f_{cn}}}{1 + \frac{f_{c1} \cdot f_{c2}}{f_{cn}^2}}$$

Where f_{c1} and f_{c2} are the individual lower limiting frequencies for each preamplifier and f_{cn} is the frequency for which the maximum difference is required. This relationship holds true for preamplifiers containing 6 dB/octave (20 dB/decade) filters. If the filter slope is 12 dB/octave (40 dB/decade) then the phase angle is twice as big and the expression above becomes

$$\Delta\phi = 2\tan^{-1} \frac{\frac{f_{c1}}{f_{cn}} - \frac{f_{c2}}{f_{cn}}}{1 + \frac{f_{c1} \cdot f_{c2}}{f_{cn}^2}}$$

3.7.3 Overload Indicator

An essential and unique feature of Brüel & Kjær preamplifiers is the overload warning facility. This effectively eliminates the possibility of making misleading measurements by monitoring the signal levels at the output of the input amplifier, the output of the filter and the output of the output amplifier (see Fig. 3.25). Only this arrangement can ensure that overloaded signals are not masked by filtering. Overload conditions are indicated by a small lamp. The overload circuitry can respond to peak overloads as short as 20 μ s. A 20 dB from overload indicator is also a very useful feature. The input and output gains can be adjusted until this light comes on. This means that the dynamic range of this part of the system is optimized.

3.7.4. Reference Oscillator

This facility is for use in system calibration and checking. It is particularly useful when making measurements in the field using portable tape recorders. A reference signal can be recorded on to the tape along with the vibration signals and later used to help calibrate the recordings. It can also be used to define levels when using level recorders and measuring amplifiers.

3.7.5. Power Supplies

Brüel & Kjær preamplifiers can be powered in several ways. Consult the tables in Appendices E and F.

Whenever possible a dual polarity power supply should be used because in this way there is greater suppression of common mode signals and power supply noise. This is particularly useful in large multichannel vibration measurement setups.

Battery power supplies make the instrument fully portable and also reduce system noise. Both of these features are particularly useful in outdoor measurements.

Up to twelve dual polarity supplies are available from the Power Supply Type 2805 which is also capable of providing 12 single polarity supplies.

4. ACCELEROMETER PERFORMANCE IN PRACTICE

4.1. INTRODUCTION

This chapter provides guidelines for the correct use of the piezoelectric accelerometer to obtain accurate vibration measurements. Figure 4.1 illustrates the many different extraneous inputs which may be present during a vibration measurement. The Delta Shear[®] accelerometer is designed to minimize the contribution of all these phenomena to ensure that the output is related only to the vibration input. Two general areas are considered:

1. **The environment.** A vibration transducer which is totally immune to environmental effects does not exist. However, it will be shown that the Delta Shear[®] accelerometer offers excellent performance in extreme environments. The sensitivity to environmental effects is very low and is well defined.

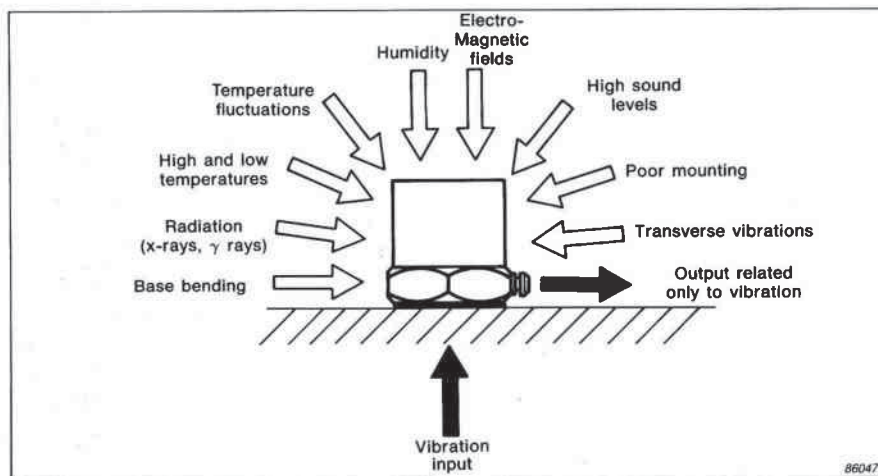

Fig. 4.1. A selection of the many extraneous inputs which can result in non-vibration related outputs in a poorly designed vibration transducer

2. **Mounting.** The mounting technique can alter the frequency response and dynamic ranges of the accelerometer. In addition, consideration must be given to the accelerometer mass as well as its mounting location. The guidelines set out in this chapter must be followed if optimum performance is to be obtained.

4.2. ENVIRONMENTAL EFFECTS

Vibration measurements often need to be made in environments which place special demands on the accelerometer. To make reliable measurements it is important to design a transducer with maximum suppression of *all* environmental influences. To this end, there have been numerous accelerometer designs. None, however, have been able to match the Delta Shear[®] design in suppressing environmental effects. Its low sensitivity to extreme environments is well defined and the effect of, for example, an excessively high temperature or a strong magnetic field, can be calculated and its contribution to the overall measured vibration level can be estimated.

Each Brüel & Kjær accelerometer is supplied with very comprehensive specifications relating to the sensitivity to environmental effects. The methods of measuring these effects are described in International Standards and in particular to ISO 5347, "Methods for the Calibration of Shock and Vibration Pickups" and also the American standard ANSI S2.11-1969, "The Selection of Calibrations and Tests for Electrical Transducers Used for Measuring Shock and Vibration".

4.2.1. Temperature Range

The piezoelectric accelerometer is capable of vibration measurements over a wide temperature range. However, due to the properties of piezoelectric materials, variations of both voltage and charge sensitivities as well as impedance will occur when the accelerometer is operated at temperatures other than the reference.

As an example, Fig. 4.2 shows the variation in capacitance, charge sensitivity and voltage sensitivity of piezoelectric material PZ 23 which is the material used in nearly all Brüel & Kjær accelerometers. Included on the calibration chart supplied with each accelerometer is a similar diagram containing information on the type of piezoelectric material used in that accelerometer. These changes in sensitivity are well defined and no permanent change occurs when the temperature is returned to the calibration temperature. When using the accelerometer at high temperatures its actual sensitivity, taking into account the change in sensitivity due to the increased operating temperature, can be determined using such a diagram.

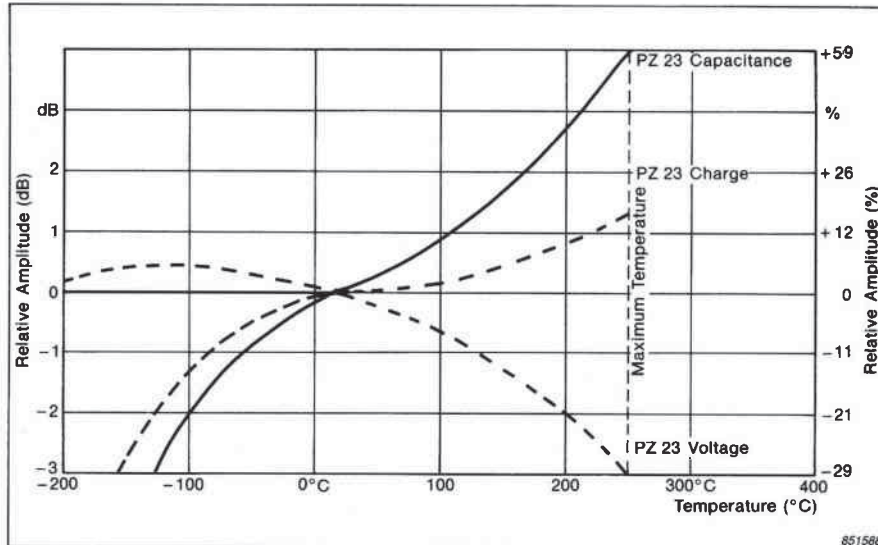

Fig. 4.2. The temperature dependency of the capacitance, charge sensitivity and voltage sensitivity of piezoelectric material PZ 23

The time required for the sensitivity to return to the one stated on the calibration chart is not easy to determine but it will partly depend on the temperature to which the accelerometer was taken. If the ambient temperature changes slowly then the sensitivity of the accelerometer will follow the curve shown in Fig. 4.2. However, for rapid temperature changes the piezoelectric exhibits a hysteresis-type effect and the accelerometer will take some time to stabilize at the sensitivity indicated on the chart. In general a period of 24 hours is required for an accelerometer to return to the calibrated sensitivity when it is suddenly returned to room temperature from a temperature close to its maximum operating temperature.

Each accelerometer has a specified maximum operating temperature above which the piezoelectric element will begin to depolarize and cause a permanent change in sensitivity. This is 250° C for those accelerometers using PZ 23 piezoelectric material. At temperatures up to 50° C above the specified limit the loss is gradual. If it is any higher then rapid depolarization takes place and the accelerometer is ruined.

For high temperature work above 250° C the Industrial Accelerometer Type 8310 can be used. This has been designed for use up to 400° C. It is possible to thermally isolate the base of a general purpose accelerometer from the vibrating surface using a screen made of a metal with high thermal conductivity such

as that shown in Fig.4.3. This increases the rate of heat transfer away from the accelerometer. Such a screen enables measurements to be made on surfaces with temperatures up to 350°C. If a stream of cooling air is also directed at the accelerometer it is possible to measure on surfaces up to 450°C. However, it must be remembered that the stiffness at the mounting point of the accelerometer may be altered by such a fixture and this in turn will lower the resonance frequency of the accelerometer when mounted and decrease the useful frequency range. The associated measuring instruments will in general have a lower temperature capability and may need to be mounted at some distance from the accelerometer.

The lower temperature limit for most Brüel & Kjær accelerometers is specified as -74°C. Specifications have not been defined at temperatures below this although it is still possible to use general purpose accelerometers at even lower temperatures. Using general purpose accelerometers, vibration measurements on structures have been made at liquid nitrogen temperatures (-196°C).

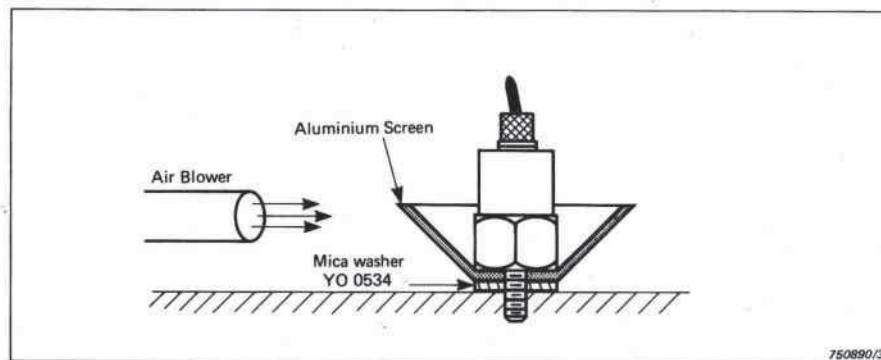

Fig. 4.3. Mounting an accelerometer on a hot surface using an aluminium screen to increase the heat dissipation

4.2.2. Temperature Transients

Fairly rapid fluctuations in the ambient temperature (due to draughts and thermal currents, for example) during a vibration measurement can give rise to a low frequency noise signal from the accelerometer. This signal is due to two effects.

1. **The Pyroelectric Effect.** This is a phenomenon whereby piezoelectric crystals and ferroelectric ceramics, become charged by temperature inequalities and temperature changes. In artificially polarized ceramics this charge is built up on the surfaces *perpendicular* to the polarization direction. Therefore when the vibration induced charge is picked up *perpendicularly* to

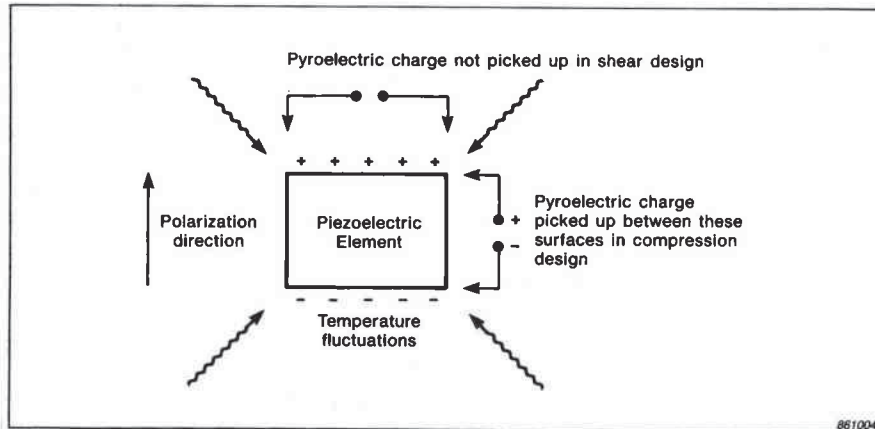

Fig. 4.4. The immunity to temperature fluctuations of a piezoelectric material in shear mode compared to compression mode. The charge shown is caused by the pyroelectric effect and is not correlated with the vibration

the polarization direction, as in compression designs, this pyroelectric charge is also picked up and erroneous outputs result. However, in a shear design this extra charge is not picked up as the charge pick up points are on the surfaces *parallel* to the polarization direction. This is illustrated in Fig. 4.4.

As a direct result of this, shear types are theoretically insensitive to temperature transients. In practice they are approximately 100 times less sensitive to temperature transients than compression types. At Brüel & Kjær careful choice of piezoelectric elements also helps to minimize this effect.

2. **Non-uniform thermal expansion.** This is possible when parts of the accelerometer structure expand or contract at different rates or the accelerometer is subjected to a heat differential across its case. Both phenomena result in forces on the piezoelectric element and a resultant output. Compression constructions are more susceptible to these effects than shear constructions.

These effects will only become noticeable when low level, low frequency vibrations are measured. In the case of outdoor measurements on large structures such as buildings, bridges or ships where the prevailing wind may cause sudden cooling effects it is vital to use an accelerometer designed to give low sensitivity to these effects. Many industrial environments may also present potential temperature fluctuation problems but as most measurements are made at high vibration levels the effects are not so serious.

The typical temperature transient sensitivity for each accelerometer type can be found on the calibration chart supplied with each accelerometer. It is possible to reduce or even eliminate the low frequency noise caused by these temperature fluctuations using one or more of the following methods.

- 1. Correct Choice.** The most important of all the factors concerning the reduction of temperature transient effects is the correct choice of accelerometer design. Delta Shear[®] design is far superior to compression design.
- 2. High Pass Filters.** If a compression type is used it may be necessary to use a high-pass filter to remove the spurious low frequency output. Such filters are included on most of the Brüel & Kjær preamplifiers used for vibration measurements. Lower limiting frequencies are selectable and are typically 0,3 Hz up to 30 Hz. A lower limiting frequency of greater than 3 Hz is necessary when using compression design accelerometers in environments where the temperature is fluctuating. Line-Drive amplifiers such as the Type 2644 or those built in to Accelerometer Types 4390, 8317 and 8318 have specified lower frequency limits which minimize these effects. For details of the individual preamplifiers and Line-Drive Types consult the Product Data Sheets available on these products.
- 3. Shielding.** In some cases it may be possible to attach a screen or light thermal insulator around the accelerometer. A microphone windshield is often suitable for this purpose. Alternatively one can be constructed from a light polystyrene material.

4.2.3. Acoustic Sensitivity

Most vibrations are associated with an acoustic output. Vibration measurements are often made in environments where there is a high sound pressure level. Brüel & Kjær Delta Shear[®] accelerometers have been designed so that high sound pressure levels (SPL) do not interfere with the vibration measurement. This is achieved by using a rigid mechanically isolated design. The typical acoustic sensitivity of a Delta Shear[®] accelerometer is in the range 0,0001 to 0,004 ms⁻² for an SPL of 154 dB in the 2 to 100 Hz range¹. Other constructions have considerably higher sensitivities than this. Older compression type designs effectively acted like microphones because there was no mechanical isolation between the case and the piezoelectric discs.

In many cases the acoustically induced vibration of the test structure will be a more important factor to consider.

¹ The acoustic sensitivity is measured in this range but is probably constant up to higher frequencies. See section 5.5.4.

4.2.4. Base Strains

This is more easily understood if it is referred to as "base bending". Whenever an accelerometer is mounted on a vibrating structure the base will be subjected to bending forces and a resultant charge will be measured. The frequency of this charge will always be at the frequency of the vibration. Consequently, it is at low frequencies where displacements, and hence strains, are large that this effect is noticeable.

Low base strain sensitivity is particularly important in the design of a feedback compressor circuit for vibration testing set-ups. The accelerometer providing the feedback signal may be subjected to large base strains and the excitation signal to the vibration exciter will be distorted.

Brüel & Kjær accelerometers are designed to have low sensitivity to these effects by utilizing the Delta Shear[®] design. In this design the piezoelectric elements are effectively isolated from all deformations of the base. It is not necessary to employ a very thick, and hence excessively heavy base to minimize this effect as is necessary in all compression designs.

The Brüel & Kjær Type 8305 Reference Accelerometer is a compression design and utilises a beryllium disc to isolate the piezoelectric discs from base bending effects. Under the controlled conditions of calibration base bending is not a problem for this accelerometer.

Typical base strain sensitivity for a general purpose Delta Shear[®] accelerometer $0,02 \text{ ms}^{-2}/\mu\epsilon$ at a base strain of $250 \mu\epsilon$. The typical value for each type is included on the calibration chart supplied with each accelerometer.

4.2.5. Humidity Effects

All Brüel & Kjær accelerometers are of a sealed construction with either a welded or epoxy sealed housing, effectively isolating the accelerometer from the effects of humidity. When they are used in wet or extremely humid conditions it is important that the accelerometer cable and screw connector are completely sealed. Otherwise there will be a decrease in the leakage resistance of the accelerometer and a change in the low frequency response. This can be achieved using a sealing agent such as Dow Corning RTV 738, 3M Scotch Clad Strip Coating 2253 or similar compounds. Brüel & Kjær accelerometer cable sleeves are generally made of moisture impervious PTFE or PFA (Teflon) and can be completely immersed in liquids.

4.2.6. Magnetic Sensitivity

Brüel & Kjær accelerometers are very insensitive to magnetic fields. The sensitivity lies between 0,5 and 30 ms⁻² per Tesla (0,005 and 0,3 g per k Gauss) which is a worst case situation with the magnetic flux flowing in the direction of the maximum sensitivity.

4.2.7. Radiation Effects

With the exception of line-drive designs, all Brüel & Kjær accelerometers may be used under gamma radiation conditions (100 Gy/h, 6 MeV) up to accumulated doses of 20 kGy (1 Gy=100 rad). Tests indicate that these accelerometers show less than 10% sensitivity change after such exposure. Normal types of accelerometer cable may be used but special cables are recommended for accumulated doses exceeding 1 kGy. The Industrial Accelerometer Type 8310 shows less than 3% change in sensitivity at these doses and can be used under very high radiation conditions. With accumulated doses of 1 MGy and 10¹⁸ neutrons per square centimetre (10kGy/h, 1 to 5MeV and a thermal neutron flux of 10¹² neutrons per square centimetre per second) a sensitivity change of approximately 5% is obtained. For further details consult the Product Data for Industrial Accelerometers.

4.3. MASS LOADING EFFECTS OF ACCELEROMETERS

When an accelerometer is mounted onto a vibrating specimen the increase in overall mass, combined with a change in the local stiffness, will inevitably alter the dynamic properties of the structure.

These changes are only significant if the accelerometer introduces an additional mechanical impedance of similar magnitude to that possessed by the structure before the addition of the accelerometer. The mechanical impedance, Z_a , presented to the structure by the accelerometer can be expressed in terms of its mass m_a

$$Z_a = \omega m_a$$

This is valid at frequencies up to 0,9 times its mounted resonance frequency. Within this frequency range the acceleration of the part of the structure near the accelerometer is modified according to the following relationship;

$$a_m = a_s \frac{Z_s}{Z_s + Z_a} \approx a_s \frac{m_s}{m_s + m_a}$$

where

- a_m = acceleration measured by the accelerometer
- a_s = acceleration of the structure when the accelerometer is not present
- Z_s = mechanical impedance of the unloaded structure
- m_s = "mass" of the structure. In many cases the mechanical impedance is mainly the mass of the structure near the accelerometer

There will also be a reduction in the resonance frequencies of the structure according to this relationship

$$f_m = f_s \sqrt{\frac{m_s}{m_s + m_a}}$$

where

- f_m = any resonance frequency of the structure with the influence of the accelerometer mass
- f_s = any resonance frequency of the structure without the influence of the accelerometer mass

These relationships show that if accelerometer mass, and hence mechanical impedance, are kept small compared to the mass of the structure then any changes in the vibration will only be small. A general rule is to ensure that the accelerometer mass is less than one tenth of the mass of the structure.

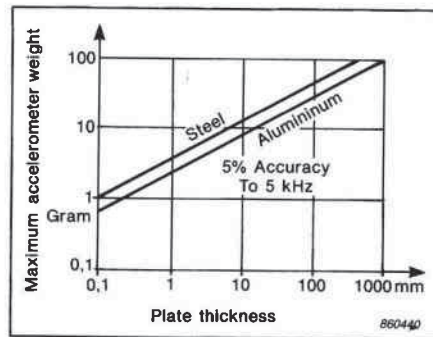

Fig. 4.5. Theoretically derived relationship between accelerometer mass and change in vibration of thin aluminium and steel plates

Fig. 4.5 shows a theoretically derived relationship between the required accelerometer mass and the thickness of a plate for a specified change in the acceleration level over a defined frequency range. This can be used when measuring vibration on light aluminium and steel plates.

4.4. MOUNTING THE ACCELEROMETER

To measure vibration accurately one must ensure that;

1. The useful frequency and dynamic ranges are not limited by poor accelerometer mounting.
2. The addition of the accelerometer mass does not alter the vibration characteristics of the test object.
3. The measurement point can be exactly located repeatedly thus ensuring repeatable measurements.

The selection of the correct mounting arrangement can significantly affect each of these criteria. It has already been seen that the useful frequency range of the accelerometer is determined by its mounted resonance frequency quoted on the individual calibration chart for each accelerometer. The mounted resonance frequency is measured under optimum mounting conditions using the standard mounting studs on a 180g steel block whose surfaces have been finished to the standard defined in Fig. 4.6.

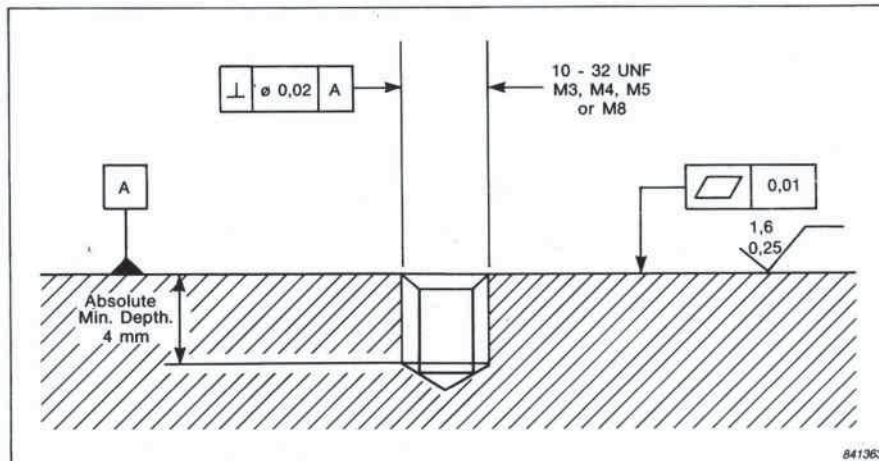

Fig. 4.6. Recommended tolerances for the mounting surface and tapped fixing hole. Dimensions and symbols in accordance with ISO 1101

4.4.1. Vibration Test Specimen Surface Finish Requirements

It is very important that the surface of the test specimen is as clean and smooth as practically possible in order to have a high mounted resonance frequency. If possible, the surface should have the finish defined in Fig. 4.6. The hole for the accelerometer stud must also be tapped according to the standards set out in Fig. 4.6. Unwanted grease can be removed by using commercially available solvents such as acetone.

4.4.2. Mounting Location

In many cases the accelerometer mounting location is fairly obvious and will be dictated by the reason for measuring the vibration. The accelerometer should be mounted with its main sensitivity axis aligned with the desired measurement direction.

However, it has already been mentioned that the accelerometer responds to vibrations in directions other than the main sensitivity axis. The red dot on B & K accelerometers can be aligned with the direction of maximum transverse vibration and consequently their effects will be minimized.

Choose a location which provides a short and rigid vibration transmission path to the vibration source avoiding any compliance and damping elements present in the structure such as gaskets. For example, when measuring vibrations on rotating machinery, bearing housings are often good places to mount the accelerometer.

There is often valuable information to be found in directions other than the one in which we mount the accelerometer. The use of a triaxial accelerometer can provide simultaneous data concerning vibration in three mutually perpendicular axes at the same point.

The dynamic response of many structures can be very complicated and only slight differences in mounting locations can cause large differences in the measurement, particularly at high frequencies. As a general rule, never make measurements at a node point. To identify the location of the nodes and antinodes on a structure it may be necessary to perform a quick vibration survey over the structure by using a "quick test" method with a hand-held probe similar to that described in section 4.4.9.

Perhaps one of the most difficult areas of vibration to measure meaningfully is the area of vibrations applied to humans. This can cover both whole body vibration and hand-arm vibration. Both require special considerations of transducer type, frequency range, dynamic range, mounting technique and mounting location.

4.4.3. Determination of the Frequency Response of Accelerometers With Different Mounting Techniques

The following sections contain advice on mounting techniques and their influence on the frequency range and dynamic performance of accelerometers. Most feasible techniques are covered. The frequency response measurements are made with a small permanent magnet exciter to drive a moving table of 180g onto which is mounted the accelerometer. The acceleration of the table is kept constant over a wide frequency range using an electronic feedback circuit (compressor loop).

To simplify comparison the same general purpose accelerometer is used in all the measurements. Fig. 4.7 compares the most important of the frequency responses obtained by using the mounting techniques covered in this section.

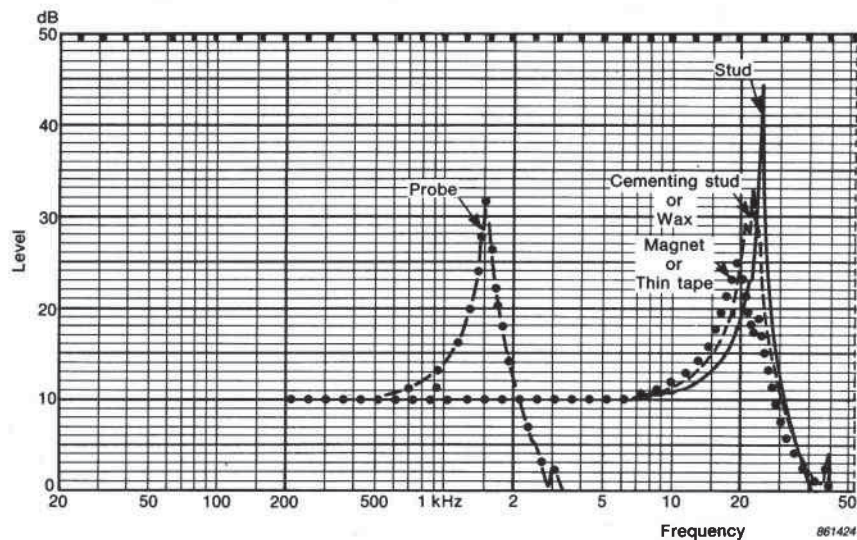

Fig. 4.7. Comparison of frequency response curves obtained using several accelerometer mounting techniques

4.4.4. Stud Mounting

Method:

1. Prepare the surface of the test object to the tolerances shown in Fig. 4.6. The accelerometer base should also be as clean and as smooth as possible.
2. Drill and tap the required size fixing hole in the test object. This will depend on the type of accelerometer. The hole must be deep enough to accept the accelerometer stud. For miniature accelerometers use the QA 0041 Tap for

M3 thread and the 8mm (0,25) inch long steel stud YQ2007. For general purpose accelerometers use the QA 0029 tap and 10-32 UNF mounting studs YQ2960 and YQ2962 which are 12mm and 8mm (0,5 and 0,312 inches) long respectively. For Type 8318 Accelerometer use the M8 tap QA 0141 and stud YQ9335.

3. Screw the stud into the hole and then the accelerometer onto the stud. Check that the stud does not bottom in the accelerometer and use a spanner to tighten the accelerometer, taking care not to overtighten it. See Fig. 4.8.

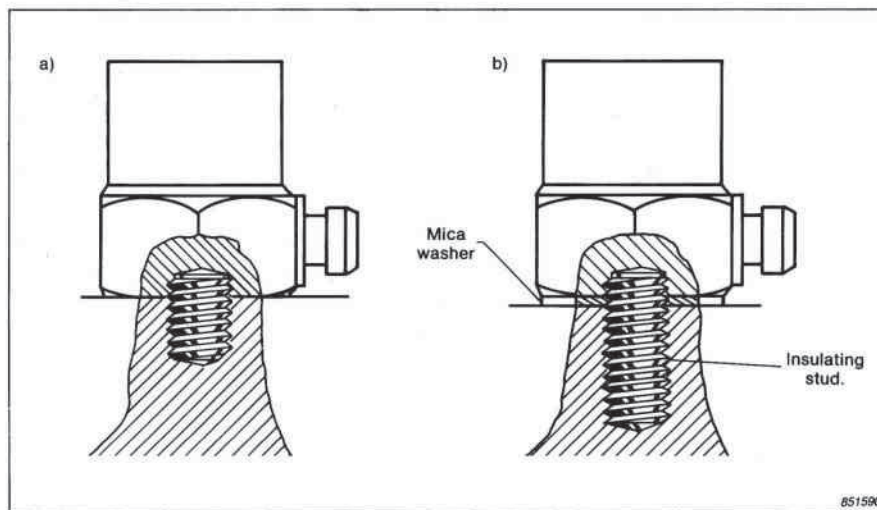

Fig. 4.8. The use of a stud to mount an accelerometer. The accelerometer on the right is mounted using the insulating stud and mica washer

Applications:

1. High frequency vibration measurements requiring the highest possible mounted resonance frequency.
2. Permanent vibration monitoring.

Advantages:

1. Optimum accelerometer performance. This method should be used whenever possible.
2. The mounting does not limit the temperature range of the accelerometer.
3. Operation at very high vibration levels.

Disadvantages:

1. It may take some time to prepare the surface of the test object and to drill and tap the hole.

Notes:

1. A thin layer of silicone grease applied between the accelerometer base and the test surface will improve the high frequency performance especially if the surface is not completely smooth.
2. The recommended torque with which to mount the accelerometer depends on the size of stud being used and is 1,8Nm for the normal 10-32 UNF stud and 0,60Nm for the smaller M3 steel mounting stud. "Fingertight" may at first appear barely sufficient ($\approx 0,3\text{Nm}$) although actual differences in the measured frequency response of the accelerometer are very slight provided that the accelerometer is tightened with a strong grip. Only when the highest frequencies are under investigation is it necessary to use a spanner to tighten the accelerometer. See Fig. 4.9.
3. Take care not to use excessive torque when using a spanner as the stud may break or the thread may be pulled out of the accelerometer. This makes it very difficult to remove from the accelerometer or test surface. The accelerometer can be ruined.
4. The stud should not bottom on the end of the accelerometer thread. If the accelerometer base is not in contact with the vibrating surface, large errors can occur.

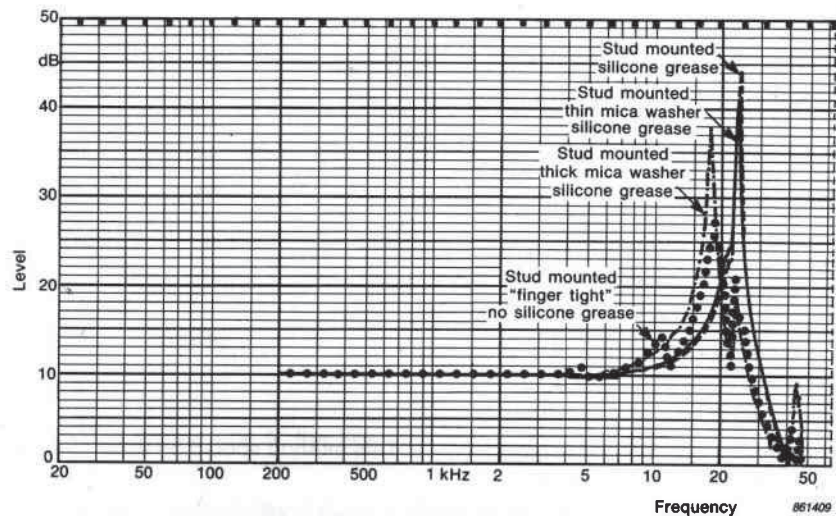

Fig. 4.9. The frequency response of a stud-mounted general purpose accelerometer using slightly different mounting techniques

5. Because ground loops can arise in vibration measurements, particularly with multi-point set-ups on large machines, it is sometimes necessary to electrically insulate the accelerometer from the test surface. This is achieved by either using an accelerometer with an insulated base or using the Mica Washer YO 0534 or YO 0746 together with an Insulating Stud YP 0150. The addition of the mica washer does however lower the mounted resonance frequency particularly at temperatures over 80° C when creeping can occur in the stud. Try to use the thinnest possible slice of mica to obtain good mechanical coupling.
6. The miniature accelerometer Type 4374 is not designed to be stud-mounted and an alternative method must be used.
7. The shock accelerometer Type 8309 has an M5 integral stud.
8. The Industrial Accelerometers are mounted with screws.

4.4.5. Wax Mounting

Method:

1. Ensure that the mounting surface is as smooth as possible. Also ensure that the accelerometer base is free from dirt and grease.
2. Scrape off a small amount of the Wax YJ 0216 supplied with the accelerometer sets and roll it with the fingers to soften it.
3. Smear the wax onto the test surface, covering an area larger than the area of the accelerometer base. The layer should be just thick enough fill out the void between the two surfaces.
4. Slide the accelerometer onto the wax and by applying pressure and turning the accelerometer it is secured to the surface. This may take a little practice. See Fig. 4.10.

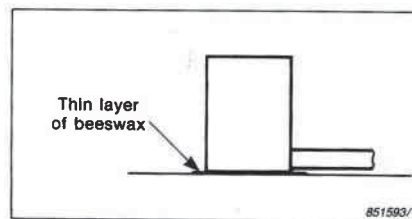

Fig. 4.10. The use of wax for mounting of a miniature accelerometer

Applications:

1. Quick test vibration measurements.

2. Measurements where it is not possible, or indeed desirable, to drill a mounting hole for a stud.
3. Attaching accelerometers which do not have a tapped hole in the base.

Advantages:

1. A quick and easy mounting option.
2. The mounted resonance frequency is only slightly less than that for stud mounting.

Disadvantages:

1. Serious temperature limitation of 40°C.
2. The maximum vibration level is approximately 100 ms⁻²

Notes:

1. The poor temperature performance is caused by softening of the wax. This causes a decrease in the coupling stiffness leading to a lower mounted resonance until eventually the accelerometer becomes detached from the test surface.
2. The use of excessive wax will lower the mounted resonance frequency and limit the measuring frequency range. See Fig. 4.11.

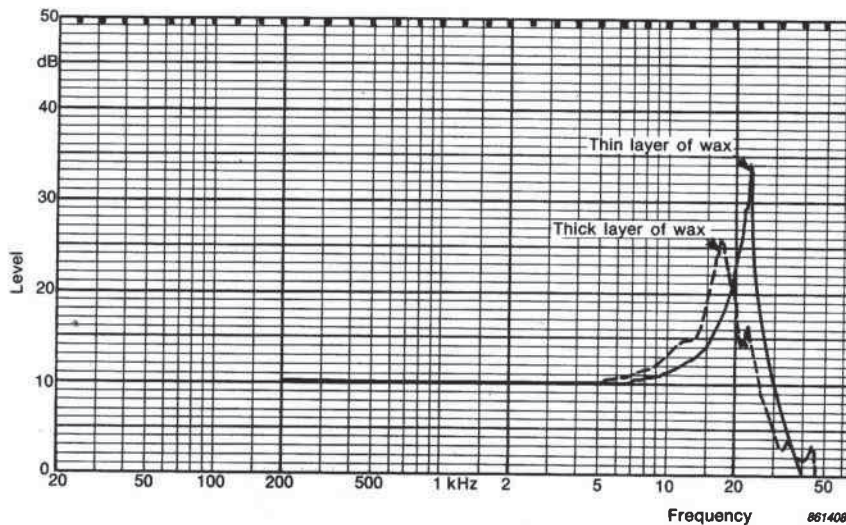

Fig. 4.11. The frequency response of a wax mounted general purpose accelerometer

4.4.6. Magnet Mounting

Method:

1. Ensure that the surface of test object and accelerometer are free from grease and protrusions.
2. Screw the accelerometer onto the permanent magnet UA 0642 and tighten with a spanner if necessary. A smaller magnet is available for mounting miniature accelerometers. High frequency response is improved by applying a thin layer of silicone grease between the accelerometer base and the magnet and between the magnet and the structure before attaching the accelerometer to the structure. See Fig. 4.12.

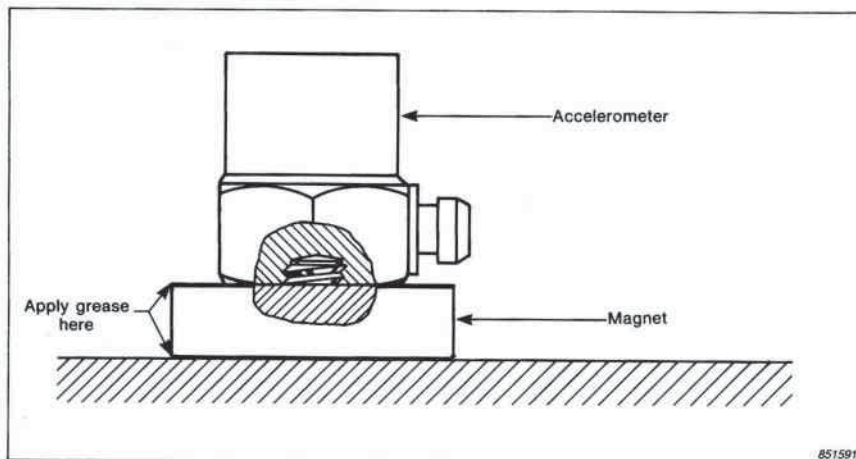

Fig. 4.12. The use of the mounting magnet UA 0642 to mount an accelerometer

Applications:

1. The rapidity of this method makes it ideal for many preliminary measurements on, for example, industrial machinery, before a decision is made on the location of a permanent vibration monitoring point.

Advantages:

1. Very rapid method.
2. Considering the apparently low coupling stiffness this method gives good high frequency performance, especially on flat surfaces. See Fig. 4.13.
3. High acceleration capability.

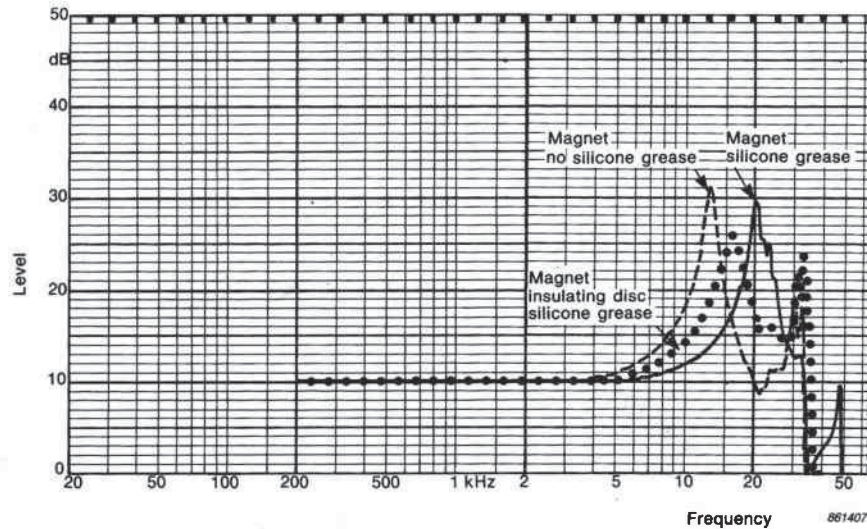

Fig. 4.13. The frequency response of a magnet-mounted general purpose accelerometer

Disadvantages:

1. The surface of the test object must be ferro-magnetic. Alternatively, a ferromagnetic disc or plate can be glued (or screwed) onto the structure.
2. Absolute repeatability of the measurement point cannot be guaranteed.
3. The addition of the magnet creates an extra mass loading effect on the structure. This could be a serious disadvantage when making measurements on light structures such as panels or plates. The magnet UA 0642 weighs 16 g.

Notes:

1. It is possible to electrically insulate the accelerometer from the test object. This is achieved by using the PTFE self-adhesive insulating disc supplied with the set of 5 mounting magnets UA 0643. The disc is placed between the surface of the test structure and the magnet.
2. Measurements are possible on curved surfaces such as pipes although the frequency range will reduce as the radius of curvature of the surface gets smaller.
3. The peak holding force of the magnet varies between 35 and 60 N, depending on the surface condition and whether insulating discs are used. Consequently the maximum vibration levels will vary according to the combined weight of the accelerometer and magnet. The Brüel & Kjær Accelerometer

Product Data contains this limit for the different types. For example, an accelerometer weighing 17 grams can be used at acceleration levels of $1,2 \text{ kms}^{-2}$ whereas an accelerometer weighing 175 grams can only be used up to $0,2 \text{ kms}^{-2}$

4.4.7. Self-Adhesive Mounting Discs

Method

1. Ensure that the vibration test surface and accelerometer are free from grease.
2. Peel off the protective backing film of the disc and apply the disc firmly to the accelerometer. See Fig. 4.14.
3. Attach the accelerometer to the vibrating surface.

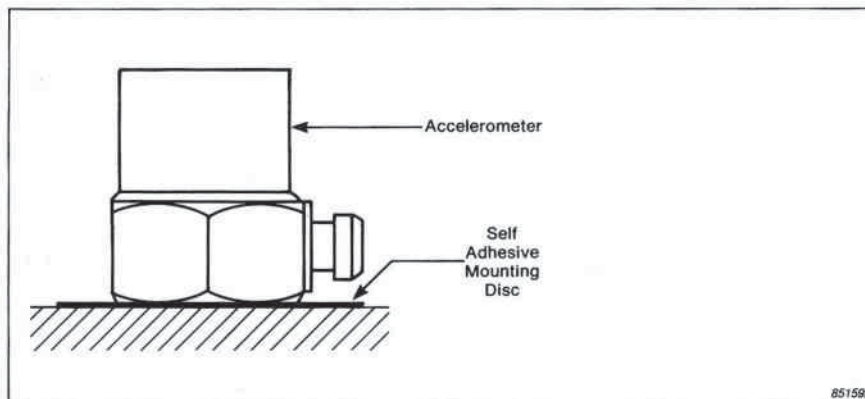

Fig. 4.14. The use of a self adhesive mounting disc to mount an accelerometer

Applications:

1. Quick test vibration measurements.
2. Measurements where it is not possible, or indeed undesirable, to drill a mounting hole for a stud.
3. Attaching accelerometers which do not have a tapped hole in the base.

Advantages:

1. Rapid method giving reasonable high frequency response and high acceleration capability.
2. Electrical insulation is provided.

Disadvantages:

1. High and low temperature operation limitations.

Notes:

1. Double sided self-adhesive discs are available in two diameter sizes- 40 mm Discs (DU0079) and 5,5mm Discs (YO0073). The smaller variety come in sets of 25 and are designed for use with the miniature type accelerometers whereas the larger one is supplied as a single item and is capable of securing the largest accelerometer at any angle with sufficient adhesive force to maintain a reasonably high frequency performance. See Fig. 4.15. However it must always be remembered that this and the other methods only approximate to the superior performance obtainable with stud mounting.
2. Double-sided adhesive tape can also be used and good results are obtainable if the tape is thin. However if the tape is very thick then the high frequency performance will be reduced.

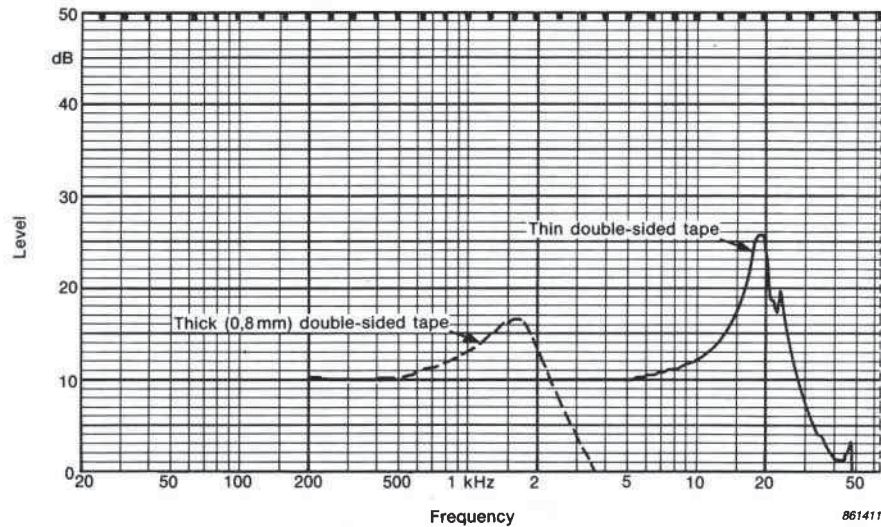

Fig. 4.15. The frequency response of a general purpose accelerometer mounted with a self-adhesive disc

4.4.8. Adhesives

There are two basic methods for using adhesives to mount an accelerometer.

Direct Attachment:**Method:**

1. Ensure that the surface is as smooth as possible and free from dirt.
2. Use a quick setting cyanoacrylate type adhesive to secure the accelerometer to the test structure following the instructions given with the adhesive. See Fig. 4.16.

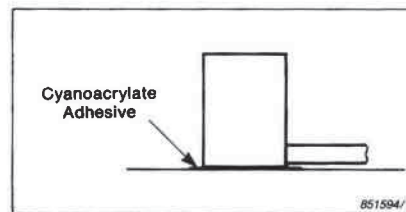

Fig. 4.16. The use of cyanoacrylate adhesive to mount a miniature accelerometer

Applications:

1. This method is very commonly used with the miniature range of accelerometers.
2. Permanent vibration monitoring where it is not possible to use stud mounting.

Advantages:

1. Excellent high frequency performance and high acceleration levels.

Disadvantages:

1. It is not very easy to remove the accelerometer from the surface and in all cases it will be necessary to clean the accelerometer afterwards with a suitable solvent. This may take some time.
2. Repeatability of the exact mounting location cannot be guaranteed.
3. Electrical insulation is difficult.

Cementing Stud Mounting**Method:**

1. Ensure a smooth, grease-free mounting surface.
2. Select the appropriate cementing stud and glue this to the test surface using

an epoxy adhesive and allow this to dry. This may take up to 30 minutes depending on the glue used. Araldite® is recommended.

3. Screw the accelerometer firmly onto the stud using the fingers. A spanner should only be used with care. See Fig. 4.17.

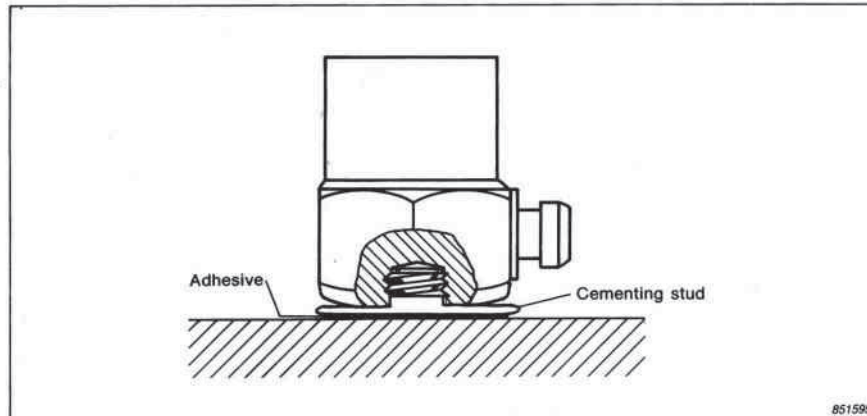

Fig. 4.17. The use of a cementing stud to mount an accelerometer

Applications:

1. Multi-point vibration monitoring where the accelerometer is regularly moved from one location to another and repeatability is required but normal stud mounting is not possible.

Advantages:

1. Good all round measurement characteristics.

Disadvantages:

1. Time-consuming (if epoxy adhesives are used).
2. It can be difficult to remove the stud and the hardened glue from the test surface.
3. Electrical insulation is difficult. However, the addition of two glass fibres under the cementing stud can provide good insulation. Alternatively, the stud can be painted with a thin layer of epoxy and left to cure before cementing on to the surface.
4. Typical maximum temperature limitation of 80° C, depending on the adhesive in use. Several higher temperature adhesives are available, such as 3M Cyanolite HG303 which can be used to 200° C.

Notes:

1. Cyanoacrylate cement can only be used on the smoothest surfaces. This is because the protrusions of rough or milled surfaces such as the base of the cementing stud can "store" air pockets which reduce the adhesive effects of this type of cement.
2. Epoxy adhesives can be used to glue the accelerometer direct to the surface although they are not as quick as the cyanoacrylate types.
3. "Soft" adhesives are **not** recommended because of the reduction in coupling stiffness which greatly reduces the frequency range. See Fig. 4.18. "Soft" adhesives also have inferior high temperature performance characteristics.
4. Suitable methyl cyanoacrylate adhesives are 3M Cyanolite 101 and Perma-bond 747 which have the Brüel & Kjær order no. QS 0007. These may be used at temperatures from -50°C to 80°C . Other types are Eastman (Kodak) 910MHT and Loctite IS.
5. A spanner should only be used with extreme care for tightening the accelerometer on to the cementing stud. Experience has shown that, when removing the accelerometer, instead of the accelerometer first unscrewing from the stud, the stud breaks away from the test surface and leaves the cementing stud screwed tightly into the base of the accelerometer. This can be very difficult to remove.

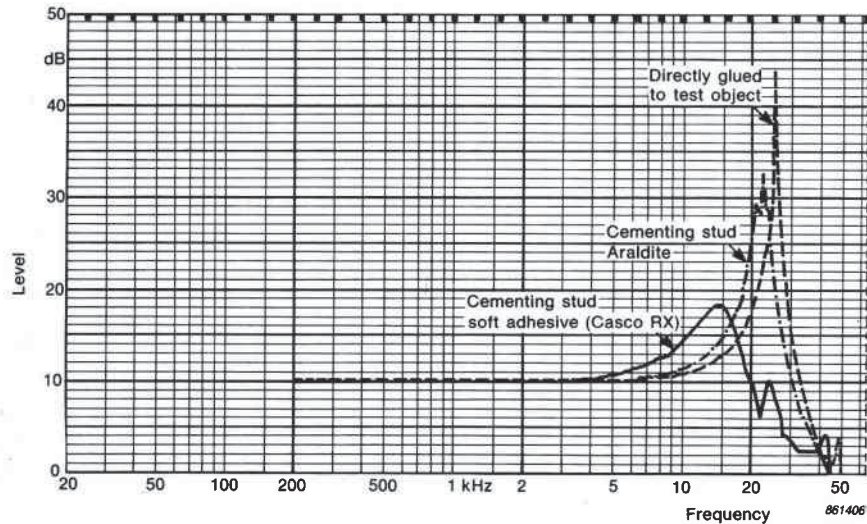

Fig. 4.18. The frequency response of a general purpose accelerometer mounted using adhesives

6. Three types of cementing stud are available. There is the 14 mm diameter DB 0756 and 25 mm DB 2790 which both use a 10-32 UNF thread compatible with the majority of Brüel & Kjær accelerometers. The former is available in a set of twenty five pieces under the number UA 0866. There is also an 8 mm diameter version with an M3 thread (DB 0757). This is available as a set of 25 (UA 0867).

4.4.9. Probes*

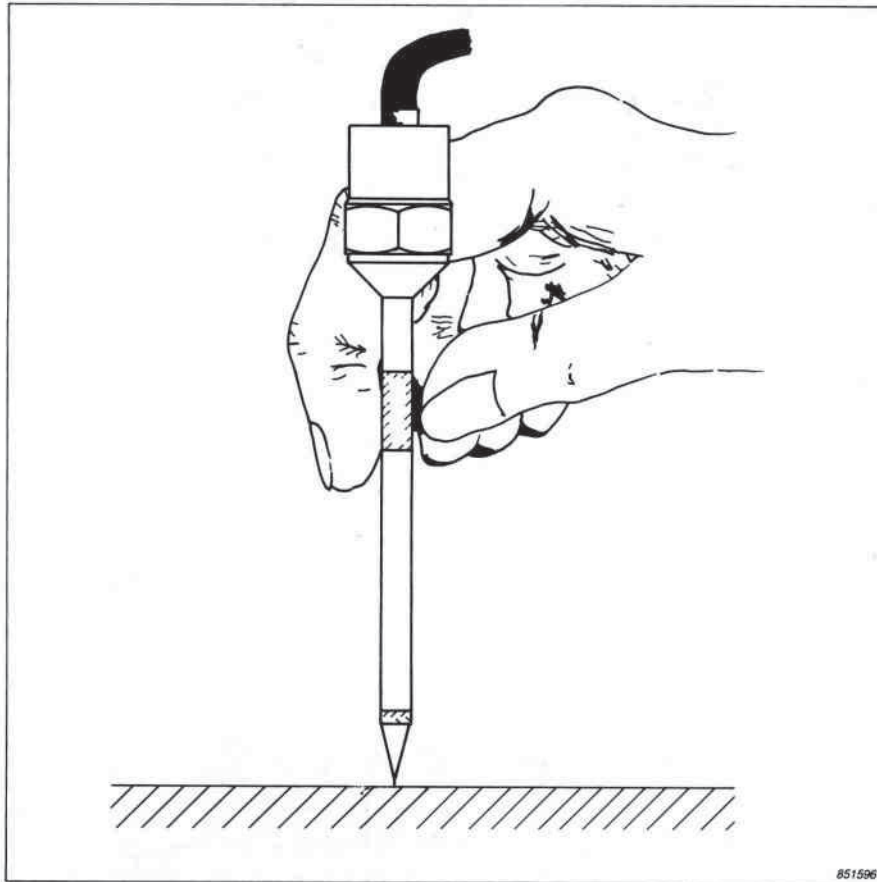

Fig. 4.19. The use of the Hand Probe YP0080 for rapid vibration measurements

* The limitations of this method must always be considered when making measurements with probes.

Method:

1. Attach the accelerometer to the Hand Probe YP0080 via the 10-32 UNF thread. See Fig. 4.19
2. Dip the tip of the probe into a small amount of silicone grease and then press the tip onto the test surface ensuring that the shaft of the probe is held perpendicular to it while preventing the tip from slipping.

Applications:

1. Only for quick spot measurements and checks below 1000 Hz.

Advantages:

1. The most rapid mounting method available.

Disadvantages:

1. The resonance frequency when mounted is brought down so low that it will lie within the frequency range of most vibration measurements and renders the results invalid. The use of low-pass filters is recommended when using one of these probes. See Fig. 4.20.
2. Very poor repeatability

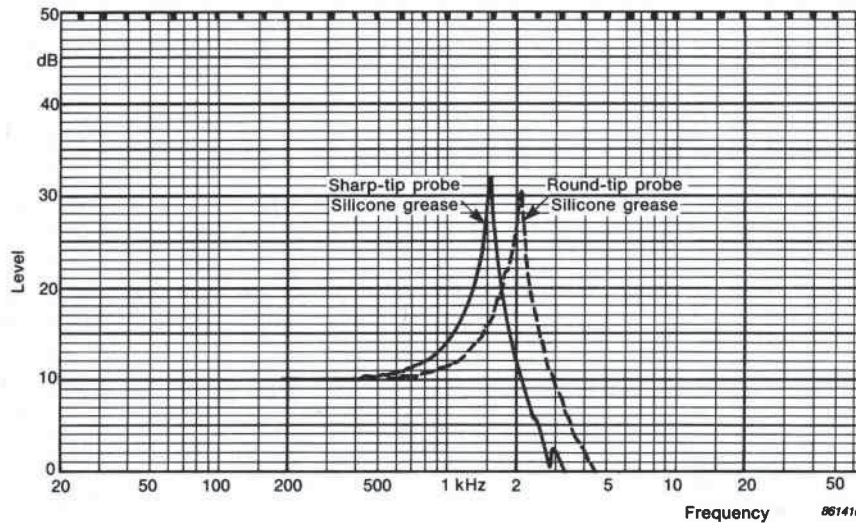

Fig. 4.20. The frequency response of a general purpose accelerometer mounted on the Hand Probe YP0080

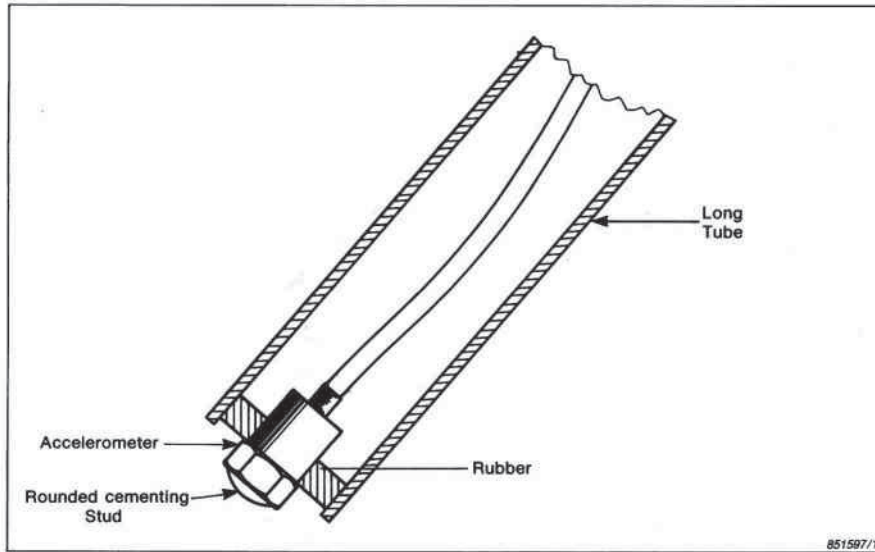

Fig. 4.21. An inverted probe. The rubber effectively decouples the probe tube so the probe resonance is not excited. The rounded cementing stud provides a smooth contact surface.

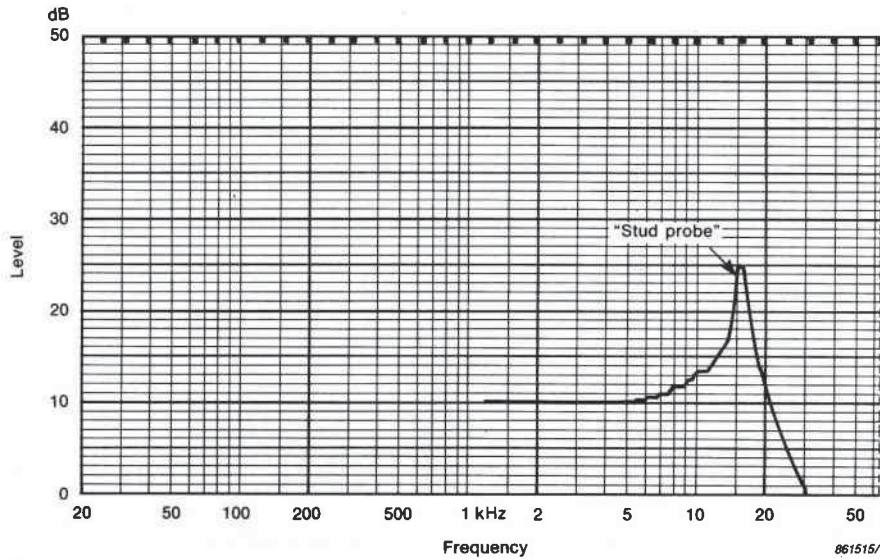

Fig. 4.22. The frequency response of a general purpose accelerometer mounted on an inverted probe

Notes:

1. The application of silicone grease is an attempt to raise the coupling stiffness. A slight extension of frequency range is obtainable when the round tip probe (DB0544) is in use.
2. An inverted probe similar to that shown in Fig. 4.21 can be constructed which allows for vibration measurements in locations where it is not possible to reach the desired measuring point. A rounded cementing-stud can be used as a probe tip. This technique can offer improved high frequency performance compared to the first probe. See Fig. 4.22.

4.5. MECHANICAL FILTERS

The mechanical filter UA 0559 is a very simple and useful device for use with most Brüel & Kjær accelerometers. It is available as a set of five (UA 0553).

The following is a short list of the applications of the mechanical filter.

1. To measure low frequency, low level vibrations which are "hidden" by high frequency, high level vibrations.
2. To protect the accelerometer from damaging high level shocks and to avoid zero shift effects.
3. To electrically insulate the accelerometer from the specimen.
4. To provide a defined upper frequency limit which is particularly useful when the preamplifier being used has no built-in filters.
5. To remove the influence of transverse vibrations.

4.5.1. Description

The Mechanical Filter UA 0559 is shown in Fig. 4.23. It has a sturdy, corrosion resistant stainless steel body with a 10-32 UNF threaded hole in the base for mounting onto test specimens and a 10-32 UNF thread screw on top for attachment to accelerometers. The upper part is bonded to an internal butyl rubber core which electrically insulates it from the base whilst at the same time acts as a low-pass filter between the structure and the accelerometer. There is a hole through the side of the mechanical filter through which a tommy bar may be passed, thus locking the top and bottom sections together and protecting rubber core from undue twisting when an accelerometer is tightened onto the device. The tommy bar can also serve as a wrench with which to tighten the filter to the vibrating surface. The recommended torque for this is 1,8Nm (15lbin).



Fig. 4.23. The Mechanical Filter UA 0559

4.5.2. Operation

The influence of the mechanical filter on the main axis and transverse response of an accelerometer is clearly shown in Fig. 4.24. It behaves as a low-pass filter, thus attenuating the main axis and the transverse axis resonances. Whereas the normal accelerometer resonance causes a sensitivity increase of about 30 dB above the nominal sensitivity, the mechanical filter causes a highly damped resonance of only 3 to 4 dB with a high frequency roll off of 40 dB/decade. An added feature is that the cut-off frequency is adjustable simply by adding extra mass between the accelerometer and the filter. Sensitivity to transverse vibrations is also reduced.

Because the filtering process is dependent on the stiffness and damping characteristics of the rubber there is a temperature dependency involved. At low temperatures the stiffness of the rubber core increases and the resonance frequency increases accompanied by a decrease in damping. At high tempera-

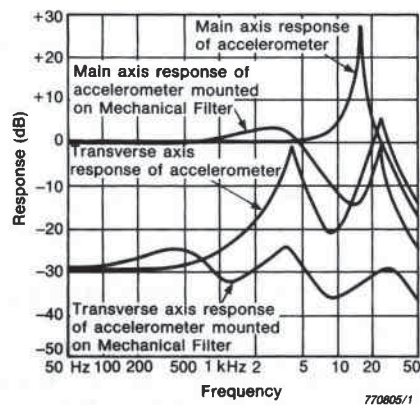

Fig. 4.24. Typical main axis and transverse frequency response of a Brüel & Kjær accelerometer when mounted on the mechanical filter

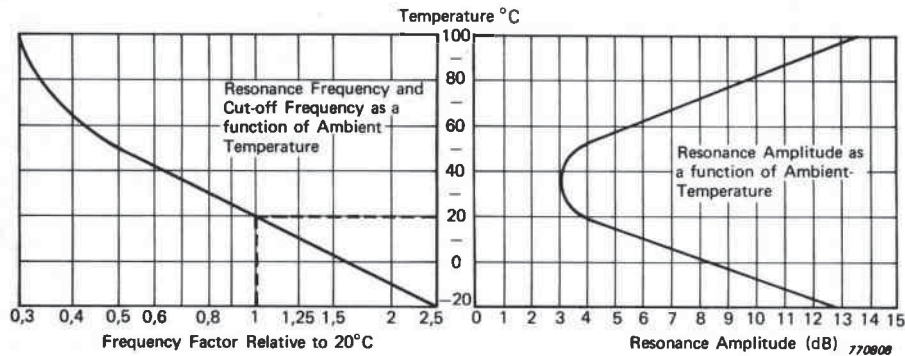

Fig. 4.25. Typical temperature response of UA 0559

tures the stiffness decreases accompanied by a decrease in resonance frequency and damping. These characteristics are shown in Fig 4.25.

If the mechanical filter is likely to be used in environments where there is oil or other hydrocarbons then it is recommended that a resistant silicone rubber sealant should be used around the top of the filter and at the entrance to the holes for the tommy bar.

Further details on the device are available in the appropriate Brüel & Kjær Product Data Sheet.

4.6. ACCELEROMETER CABLES

Incorrect vibration measurements are often caused by careless mounting and routing of the cable connecting the accelerometer to the charge amplifier. The main causes of this are as follows:

1. When a coaxial cable is subjected to bending, compression or tension the screening may become separated momentarily from the dielectric at points along its length. Local changes in capacitance are created and so-called "triboelectric" charges are formed. This effect is known as the Triboelectric Effect and is particularly troublesome when measuring low level vibrations where it appears in the form of noise.
2. Very strong electromagnetic fields can induce a voltage across the cable and this could cause extraneous noise in the measured signal.
3. In compression designs, bending forces can be transmitted to the piezo-electric discs via the connector if the cable is not prevented from vibrating.

The first of these points can be effectively reduced by using special coaxial cable with a noise reduction treatment. This is a standard feature of all accelerometer cables supplied by Brüel & Kjær. In addition the cable should not be sharply bent or twisted as this will not only reduce the noise reduction treatment but it will also damage the connectors. The cable should be clamped to the test specimen to avoid excess relative movement which causes triboelectric noise. This is illustrated in Fig. 4.26.

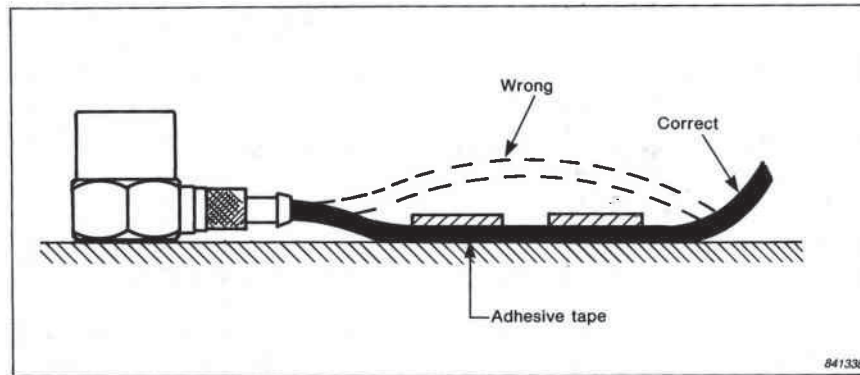

Fig. 4.26. Clamping the accelerometer cable to reduce cable noise

The second point is overcome by careful routing of the cable away from sources of high electromagnetic fields. If this is not possible then either a line-drive system or a balanced accelerometer and special cable should be used. The benefits of these systems were examined in section 3.6 and summarized in Table 3.1. Consult the Industrial Accelerometer Product Data for details of the Balanced Accelerometer Type 8310 and Differential Charge Amplifier Type 2634.

Most Brüel & Kjær accelerometer cable sleeves are constructed from moisture impervious Teflon for use in very damp environments. Additionally the cable connector may be sealed using a room temperature vulcanising rubber when the environment is particularly wet. For details see section 4.2.5 on humidity effects. For exact details on the range of cables available from Brüel & Kjær, including hard-line designs and curly cables, see the Brüel & Kjær Accelerometers and Industrial Accelerometers Product Data Sheets.

Line-Drive accelerometers require only one cable for simultaneous transmission of power and vibration signals. Ordinary two-conductor cables are often used as they are inexpensive compared to normal low-noise accelerometer cables. It should be stressed that when a line-drive accelerometer is used in environments where there are electromagnetic fields, a voltage will be induced

in the cable. This voltage corresponds to the ground loop noise described in sections 3.6.3, 3.6.4 and 3.6.6. These sections show that the Brüel & Kjær line-drive system is more immune to ground-loop noise than systems based on constant-current power supplies. However, it is always recommended to use coaxial cables with line-drive amplifiers in severe industrial environments. In less severe environments twisted-pair cables can be used.

4.7. GROUNDING PRECAUTIONS

In multichannel vibration set-ups problems are often encountered where small currents flow between the earth lines of the measuring instrumentation. This phenomena is caused by the set-up being earthed at more than one point and the potential of each earthing point being different.

Earthing can be made via the protective earth terminal of the instruments mains connector. The accelerometer housing can also form an earthing point when it is in contact with an earthed structure such as a machine. However, in some industrial environments there is always the possibility that a machine housing may not be at earth potential and may even be several volts above earth. This may be because the machine lacks a proper earth connection or the impedance of the earth connection is not zero.

The screens of connecting cables are often connected to the chassis and case of the instrument which is then connected to the ground. Therefore ground loop currents can flow from one instrument to another via the screening on the cables or via the chassis of the instruments if the cases are touching.

Ground loops manifest themselves in the form of mains "hum" which is detected at the final measuring point and effectively adds to the vibration output signal. This gives rise to false vibration level indication. To prevent this it is necessary to "break" the loop in which the current is flowing. There are several ways of doing this.

1. Ensure that the instrumentation is earthed at only one point in the chain and that this earth connection is reliable.
2. Select a charge preamplifier with an option to insulate the screen of the input cable from the ground line of the preamplifier. This is referred to as a "Floating Input". Consult section 3.6 for a detailed analysis of noise pick-up in preamplifiers.
3. Mount the accelerometer using an insulating stud as described in section 4.5.1.

In industrial environments it is advisable to use an electrically balanced and insulated accelerometer with a differential amplifier. This design of accelerometer reduces the effects of electromagnetic pick-up in the cable. The cable in this case contains two conducting cores, each with an individual screen. Both screens pick up the same interference. The differential preamplifier produces an output proportional to the *signal difference* in these conductors which, because of the design of the balanced accelerometer, effectively eliminates the effect of the electromagnetic interference. Such a design will also reduce the effects of ground loop voltages.

5. ACCELEROMETER CALIBRATION AND TESTING

5.1. INTRODUCTION

The accuracy, reliability and versatility of the piezoelectric accelerometer is only of limited value if the vibration measurements cannot somehow be traced to an absolute physical standard. It is the purpose of calibration to ensure that the benefits can be utilized and hence provide a defined degree of confidence in any vibration measurement. Accelerometer testing provides data concerning the environment and operating limits within which the calibration is valid.

Calibration Chart for Accelerometer Type 4383			Environmental: Humidity: Welded, Sealed Temperature Range: -74 to +250°C (-100 to +482°F) Max. Shock Acceleration: 20 kms ⁻² peak Typical Magnetic Sensitivity (50 Hz - 0.03 T): 1 ms ⁻² /T Typical Acoustic Sensitivity: 0,002 ms ⁻² at 154 dB SPL (2 - 100 Hz) Typical Base Strain Sensitivity (at 250 με in base plane): 0,01 ms ⁻² /με Typical Temperature Transient Sensitivity (3 Hz LLF): 0,1 ms ⁻² /°C Specifications obtained in accordance with ANSI S2.11- 1969
Serial No. <u>1230172</u>			
Reference Sensitivity at 50 Hz, 100 ms ⁻² and <u>23</u> °C		Physical: 	Electrical Connector: Coaxial 10 - 32 UNF-2A
Charge Sensitivity* <u>31.7</u> pC/ms ⁻² or <u>30.5</u> pC/g Voltage Sensitivity* (incl. AO 0038) <u>2.75</u> mV/ms ⁻² or <u>26.9</u> mV/g (Voltage Preamp. input Capacitance: 3.5 pF) Capacitance (incl. cable) <u>1134</u> pF Typical Capacitance of cable AO 0038 110 pF Maximum Transverse Sensitivity (at 30 Hz, 100 ms ⁻²) <u>1.8</u> % Typical Undamped Natural Frequency 51 kHz Typical Transverse Resonance Frequency, using Ex- citer Table 4290, with accelerometer mounted on a tita- nium cube by a 10 - 32 UNF-2A steel stud, mounting torque 1,8 Nm and greased surfaces: 10 kHz			
Polarity is positive on the center of the connector for an acceleration directed from the mounting surface into the body of the accelerometer Resistance minimum 20,000 MΩ at room temperature Date: <u>86.01.10</u> Signature: <u>J.A.</u> 1 g = 9,807 ms ⁻² or 10 ms ⁻² = 1,02 g * This calibration is traceable to the National Bureau of Standards Washington D.C.		Material: Titanium, ASTM Grade 2 Sensing Element: Piezoelectric, type PZ23 Weight: 17 gram Construction: Delta Shear Mounting Thread: 10 - 32 UNF-2B Mounting Stud: 10 - 32 UNF-2A x13 mm, steel Mounting Surface Flatness: <3 μm Mounting Torque: Normal 1,8 Nm. Min. 0,5 Nm. Max. 3,5 Nm Seismic Mass: 6,6 gram Center of Gravity of Seismic Mass: 12,1 mm from mounting surface on central axis Center of Gravity of Accelerometer: 9,2 mm from mounting surface on central axis For further information see B & K "Piezoelectric Acceler- ometer and Preamplifier" handbook	
BC 0163-12		Pat. DK 131401	

Fig. 5.1. The Calibration Chart. This section describes individual and batch calibrated specifications

Every accelerometer produced at Brüel & Kjær undergoes the strictest production and quality control techniques to ensure that the transducers are not only reliable, and indeed likely to remain reliable, but also that the spread in the parameters amongst devices of the same type is small. The accelerometers can then be individually calibrated to provide accurate data on several parameters.

Often, when we talk about calibration we are essentially referring to the sensitivity calibration. However, other parameters such as frequency response, capacitance and weight, as well as environmental effects, are given as part of the calibration information. Each accelerometer comes complete with an individual calibration chart containing extensive calibration information. Some of this information is individual to that particular accelerometer while some is typical of that type only. See Figs. 5.1, 5.2, and 5.3.

It is not the intention of this Chapter to give a step-by-step guide on how to perform the calibrations. The Instruction Manuals on the particular calibration equipment mentioned provide this information. However, the chapter will give a comprehensive overview of the calibration and testing of Brüel & Kjær accelerometers.

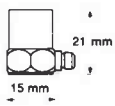
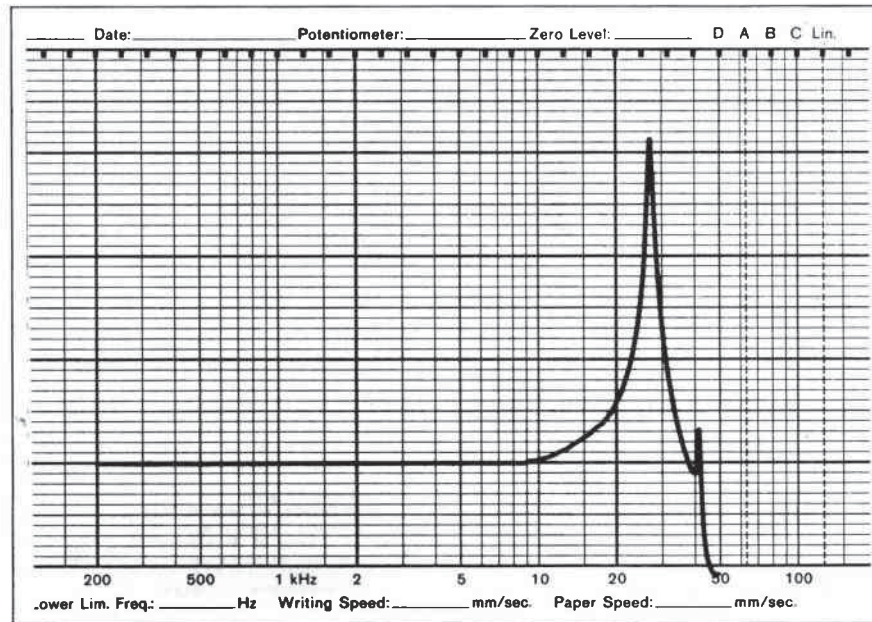

Fig. 5.2. The Calibration Chart. This section shows an individual frequency response curve

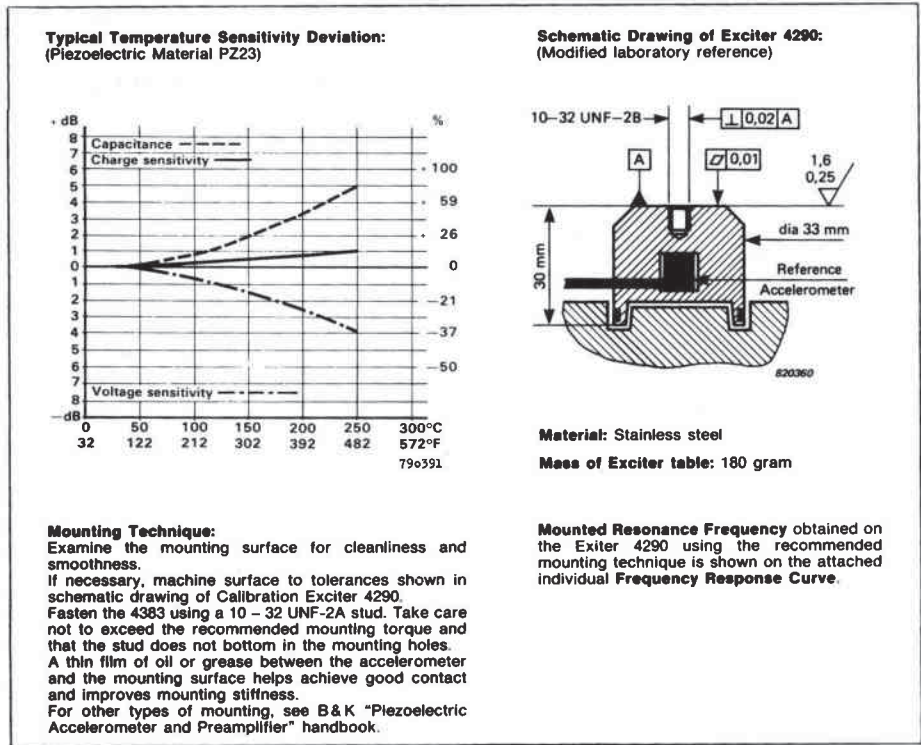

Fig. 5.3. The Calibration Chart. This section contains general information

5.1.1. Why Calibrate an Accelerometer?

There are several reasons for performing a calibration apart from the basic one of establishing the link to the physical quantity with a definable degree of accuracy. In many cases there may be legal or contractual reasons that create a requirement for evidence of the accuracy of the transducer, possibly with reference to international standards.

Situations may also arise when the accelerometer is being used in a particular set-up or environment where the performance of the accelerometer has not been documented in the calibration chart. In this case it will be necessary for the user to perform a calibration for that particular purpose. The calibration chart is sufficiently comprehensive to cover most applications.

System checking also forms an important part of the calibration process, particularly in measurement systems consisting of many instruments. Errors made in the computation of the overall system sensitivity can be avoided simply by using a quick calibration check. This is outlined in section 5.3.5.

It is always advisable, before any calibration is performed, that the frequency response of the accelerometer is measured. This will ensure that the accelerometer has not been damaged in any way. Such damage can show up as irregularities in the frequency response of the accelerometer implying that the accelerometer is ruined or, at best, that the frequency range is limited. If this is the case then the calibration is no longer valid. The measurement of accelerometer frequency response is covered in section 5.4.2.

5.2. THE HIERARCHY OF CALIBRATION STANDARDS

5.2.1. The General Hierarchy

To avoid the necessity for carrying out absolute calibrations of each individual transducer, a hierarchy of standard transducers is first established. A hierarchy of this kind is shown in Fig. 5.4.

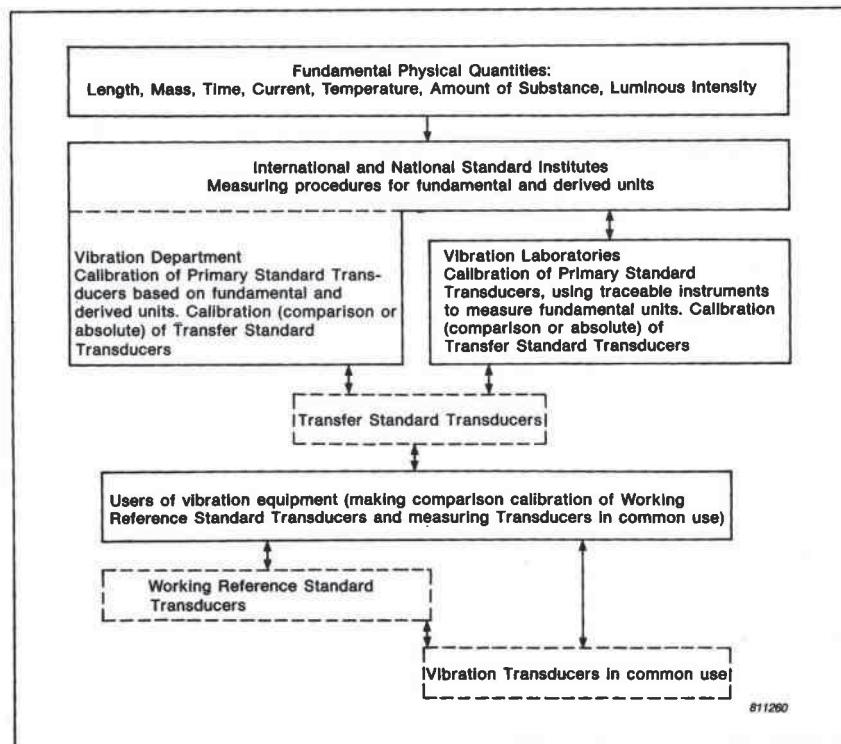

Fig. 5.4. A general hierarchy of calibration standards

Standard transducers are ranked into three groups;

- 1. Primary Standard Transducers.** By definition, a calibration method which establishes the sensitivity of a transducer in terms of fundamental or derived units for physical quantities, such as the SI system, is known as an *absolute* method. A transducer which has been calibrated in this manner is a Primary Standard Transducer and is placed at the top of this hierarchy. Such transducers are kept at the International or National Standard Institutes, or at the Calibration Laboratories where they have been calibrated.
- 2. Transfer Standard Transducers.** These transducers are calibrated by the Institutes and Laboratories mentioned above. They are calibrated either by a *comparison* method, using a Primary Reference Standard, or by an *absolute* method.

Transfer Standard Transducers are interchanged and recalibrated between Standards Institutes to establish consistency among these Institutes. Consistency between Calibration Laboratories and a Standards Institute is also established by interchanging and recalibrating Transfer Standards. In this way, *traceability* is also established. Traceability defines which Standards Institute is responsible for the establishment of the consistency of the calibration performed at a Calibration Laboratory. Therefore, a transducer calibrated at that Calibration Laboratory is designated as "traceable" to that Standard Institute.

- 3. Working Reference Standard Transducers.** These transducers are used for comparison calibration of transducers in common use. Working Reference Standards are calibrated by Standards Institutes or Calibration Laboratories using absolute or comparison methods. They are checked against Transfer Standard Transducers. In this way the traceability of the calibration of transducers in common use is maintained.

5.2.2. The Hierarchy at Brüel & Kjær

The calibration of Brüel & Kjær accelerometers begins with the Standard Reference Accelerometer Type 8305 (see Fig. 5.5).

This is a piezoelectric accelerometer based on an inverted centre-mounted compression design. The piezoelectric element is a carefully selected and prepared quartz crystal PZ 100 which has been chosen for its low sensitivity to temperature fluctuations and excellent stability over very long periods of time. A threaded hole in the top of the accelerometer allows other accelerometers to be mounted on to the top of this accelerometer for back-to-back accelerometer calibration (see section 5.3.3).

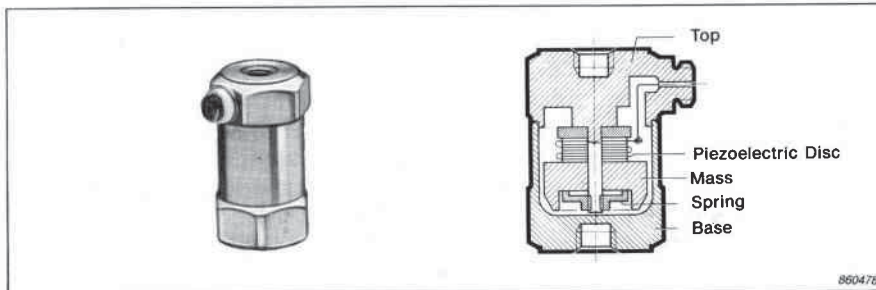

Fig. 5.5. The Standard Reference Accelerometer Type 8305

Every accelerometer of this type is absolutely calibrated by a laser interferometry technique (see section 5.3.1). In addition, a Calibration Set Type 3506 consisting of an 8305 and Type 2626 Conditioning Amplifier is laser-calibrated as an integral pair (see Fig. 5.6).

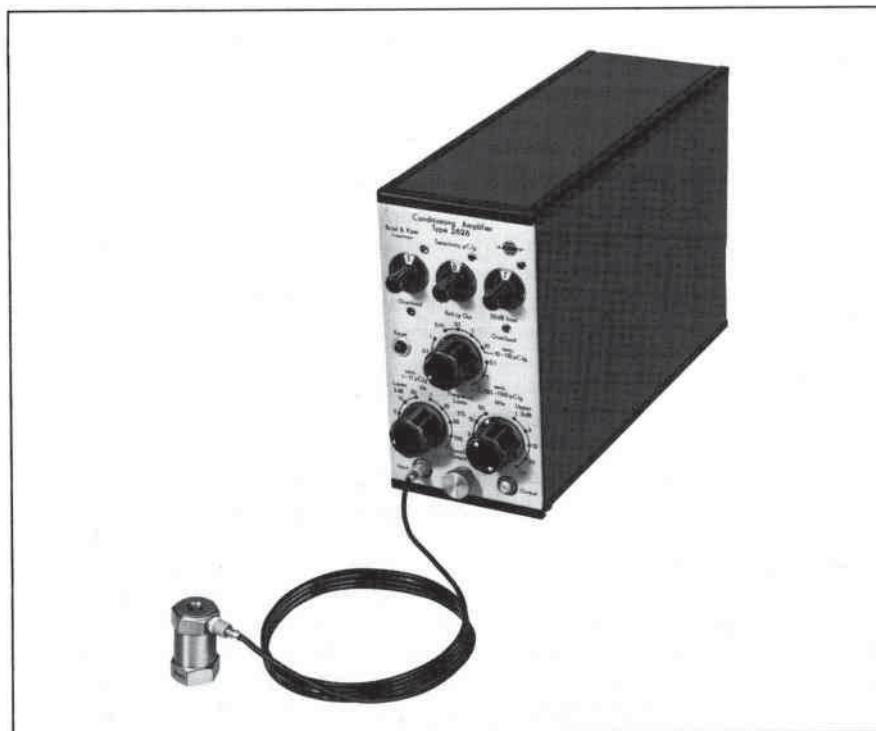

Fig. 5.6. The Calibration Set Type 3506

Two 3506's from Brüel & Kjær's calibration laboratory are regularly sent to the National Bureau of Standards (NBS) in the United States at set times throughout the year. These Transfer Standards are always transported to the NBS by hand rather than by normal mailing services. This procedure ensures that Brüel & Kjær's laser calibration is consistent and provides for all 8305's to be traceable to the NBS.

A set of Primary Standard Accelerometers is established together with a set of Supplementary Standards which are kept in Denmark as insurance against damage to any of the Primary Standards.

The remainder of the range of Brüel & Kjær accelerometers are calibrated by a semi-automatic back-to-back comparison system in-house which employs a Type 8305 as a Working Reference Standard.

A collection of Transfer Standards is established for checking the calibration systems throughout the world at several Brüel & Kjær Service Centres and other calibration laboratories. Here all types of accelerometers are calibrated for the customer by a back-to-back method using the Type 9559 Calibration System (see section 5.7.1). Other parameters may be calibrated using this system.

In this way Brüel & Kjær has evolved an efficient calibration hierarchy which can control the calibration process not only at the manufacturing stage but also for many years after the purchase of the accelerometer, while still maintaining the traceability of the calibration of any accelerometer. This hierarchy is illustrated in Fig. 5.7.

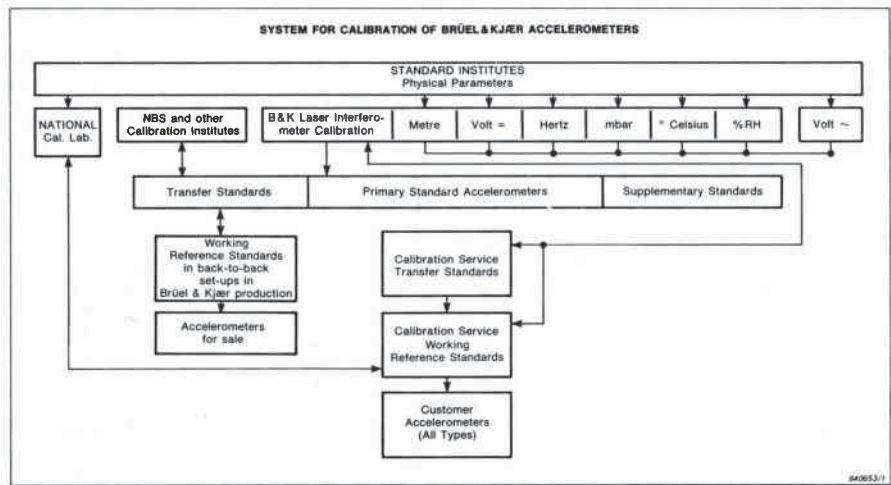

Fig. 5.7. The hierarchy of calibration at Brüel & Kjær

5.2.3. The Accuracy of Calibration Techniques

It is important to understand the difference between traceability and accuracy. Traceability only implies consistency with the calibration performed at a Standards Institute, and that the calibration is within tolerances. This means that if a Calibration Laboratory uses more accurate instruments than the Standards Institute to which they refer, the uncertainty of the calibration performed by the former will be less than that of the latter.

In order to evaluate the accuracy of various calibration methods the uncertainty of the calibration must be treated in a consistent way. At Brüel & Kjær the method described in the British Calibration Service Guidance Document No. 3003 is adopted. The document describes a method for assigning a single (\pm) value of uncertainty to the measurement, including a statement of confidence, in terms of the probability, that the true value for the measurement lies between the (\pm) limits stated. For practical convenience the contributions to the calibration uncertainty are classified into two categories

- a) random uncertainty
- b) systematic uncertainty

The uncertainty incurred in absolute and comparison calibration methods are now examined.

Absolute Method. Using laser interferometry, theoretically the amplitude of vibration can be determined to an accuracy of 0,02%. However, in practice measurement errors occur in the voltage measurement (0,1%), distortion in the vibration exciter motion (0,1%), tilting of the reference accelerometer (0,2%) and transverse motions of the reference accelerometer (0,1%). The estimated inaccuracy of the absolute calibration of the Calibration Set Type 3506 and the Standard Reference Accelerometer Type 8305 has been calculated to be 0,6% at a confidence level of 99%.

Comparison Method. This method is used by NBS to check the Brüel & Kjær Transfer Standards. It is also used by Brüel & Kjær to calibrate the range of accelerometers. It results in an estimated total inaccuracy of better than 0,95%. This must be added to the uncertainty produced by the absolute calibration of the 3506 Calibration Set described above to give an overall estimated error for this method of 1,12% at a confidence level of 99%.

It must be remembered that these figures are based on the use of Brüel & Kjær's own in-house laser calibration system which is an absolute method. However the NBS comparison system is accurate to 1%. Therefore if the NBS figures for the accuracy of the Type 3506 system are used, the overall estimated inaccuracy of the comparison method is correspondingly increased to 1,38% at a confidence level of 99%.

5.3. CALIBRATION METHODS

Sensitivity calibrations are divided into three distinct methods;

1. Absolute methods. These include Laser Interferometry and Reciprocity techniques.
2. Comparison methods. This refers to the back-to-back method.
3. Calibrators. This involves the use of a vibration exciter of known vibration level.

5.3.1. Laser Interferometry

This absolute method of calibration involves the use of very specialized equipment and it is therefore unlikely that average users of accelerometers would ever carry out their own calibration of this type.

Fig. 5.8 shows the arrangement used at Brüel & Kjær for the calibration of the Standard Reference Accelerometer Type 8305 and Calibration Set Type 3506.

The measuring arrangement centres round a Michelson Interferometer. The laser beam is directed at the upper surface of the Standard Accelerometer to be calibrated, from which it is reflected back along the same path. The beamsplitter (semi-reflecting plane mirror) of the Interferometer is located in this path and directs some of the beam reflected from the Accelerometer onto a Photodiode. Some of the Laser beam reaching the Photodiode also comes via the beamsplitter and the fixed mirror of the Interferometer, thus generating light fringes at the Photodiode. The amplified output of the Photodiode is fed into the input of the Frequency Ratio Counter which measures the number of fringes per period which is proportional to the peak-to-peak displacement of the accelerometer.

The vibration frequency (a sinewave) is generated by the Sine Generator, whose output is used as an External Clock for the Frequency Ratio Counter. The vibration amplitude is adjusted until the displayed Ratio is correct. The electrical output of the Standard Accelerometer is measured using a Conditioning Amplifier and an RMS Differential Voltmeter, both of which have been calibrated electrically.

The laser interferometer part of this set-up measures the peak-to-peak displacement of the 8305. From this the acceleration is derived using the frequency read off the frequency counter. The sensitivity is obtained by measuring the electrical output from the accelerometer and dividing by the acceleration.

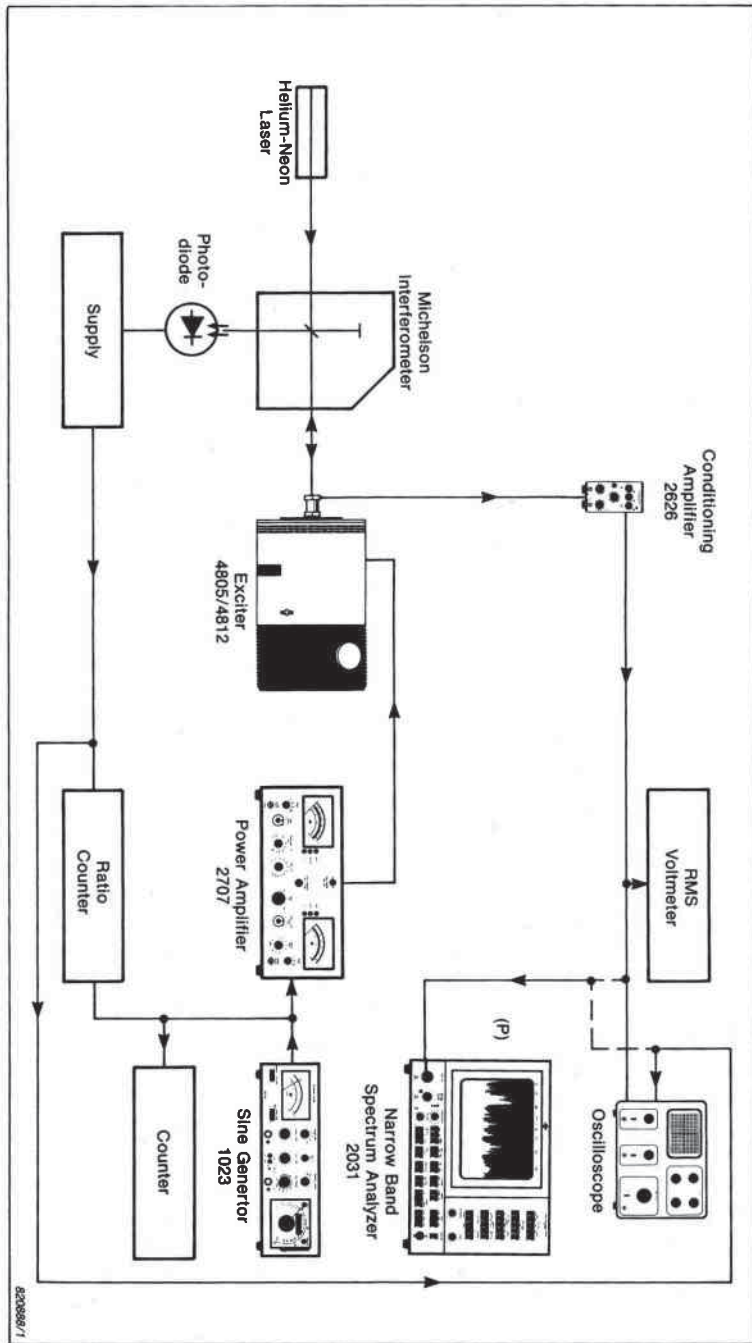

Fig. 5.8. The Laser Interferometer set-up used at Brüel & Kjær

At Brüel & Kjær the excitation frequency used is 160 Hz and the acceleration level used is 10 ms^{-2} .

5.3.2. Other Absolute Methods

Other methods of absolute calibration do exist. They are however not used at Brüel & Kjær and therefore are only briefly described here. The methods are:

1. Reciprocity Calibration. Until recently this method has been suggested in Brüel & Kjær literature as an absolute method which can be performed by anyone possessing basic, non-specialised equipment. The method is very involved and good results are difficult to obtain. The method will not be described in this handbook.
2. Calibration by using the Earth's gravity. In this method the accelerometer is carefully turned in a vertical circle so that gravity alone is acting on the accelerometer. This method is only practical at low frequencies and is sometimes used with static (DC) accelerometers and is consequently not used at Brüel & Kjær.

5.3.3. Comparison Calibration by the "Back-to-Back" Method

The back-to-back method is used at Brüel & Kjær for the factory calibration of every type of measurement accelerometer. Brüel & Kjær use a semi-automated system but a similar system can be built up by anybody wishing to perform their own comparison calibration of accelerometers.

The accelerometer whose sensitivity is to be measured is mounted in a back-to-back arrangement with a Standard Reference Accelerometer Type 8305 and the combination is mounted on a suitable vibration source. Since the input acceleration is the same for both devices the ratio of their outputs is also the ratio of their sensitivities.

The Vibration Exciter Type 4801 or 4805 fitted with the Calibration Head Type 4815 is designed for back-to-back calibration of accelerometers. The Type 4815 has a built-in Standard Reference Accelerometer Type 8305. Consult the Brüel & Kjær Product Data on this instrument for more details.

In its simplest form a back-to-back arrangement can be seen in Fig. 5.9. The accelerometers are excited at a constant frequency and their outputs are passed through preamplifiers (operating in charge or voltage mode depending on whether the charge or voltage sensitivity is of interest) and measured individually by using any high quality electronic voltmeter whose accuracy is known.

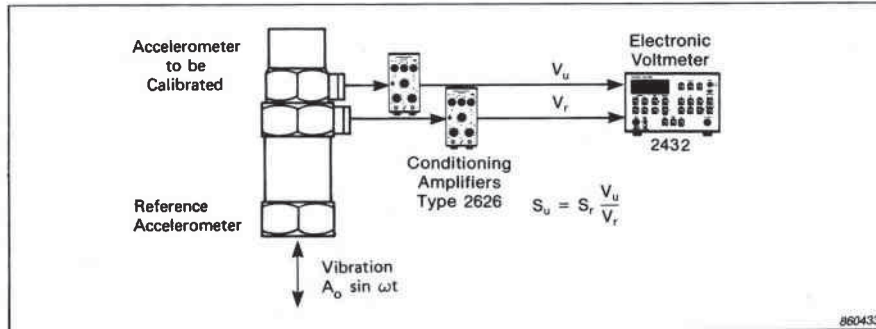

Fig. 5.9. A simple arrangement for the back-to-back calibration of accelerometers. The accelerometer signals are passed through a preamplifier before the voltmeter

The previous system can be improved by using an expanded voltmeter device such as the Sensitivity Comparator Type 2970 as part of the system (see Fig. 5.10). By adjusting the sensitivity of the preamplifier in the path of the unknown accelerometer a minimum deflection can be obtained on the 2970. The sensitivity is then simply read off the dials on the conditioning preamplifier.

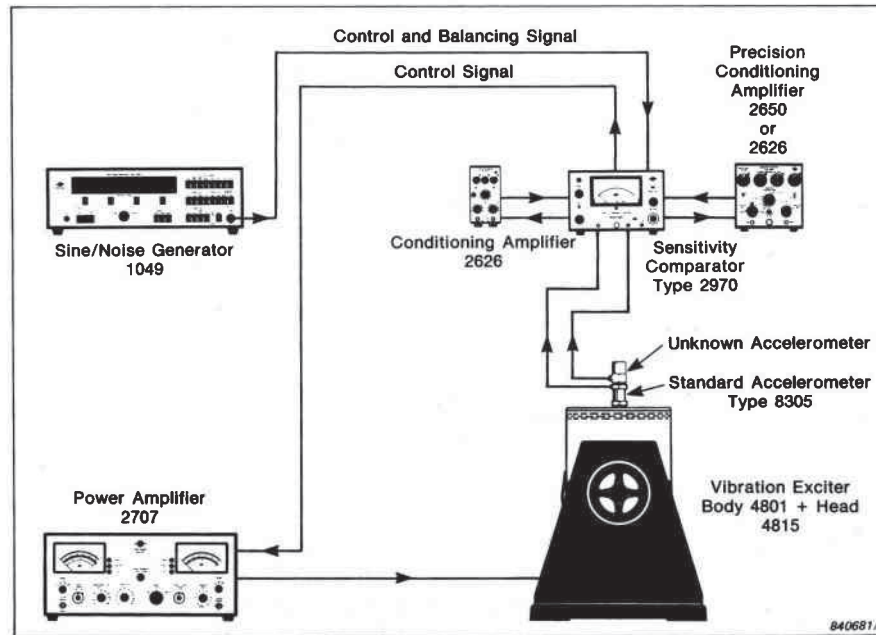

Fig. 5.10. A complete high accuracy set-up for the back-to-back calibration based around the Type 2970 Sensitivity Comparator

The Type 2970 performs the following roles:

1. Simplifies the comparison of the outputs.
2. Increases the speed of the procedure.
3. Gives calibration accuracy similar to the one obtained by Brüel & Kjær's own factory calibration and that of NBS.
4. Performs voltage-to-charge conversion for voltage and charge calibrations.

The calibration frequency and acceleration level will vary according to the standard with which it is necessary to comply. At Brüel & Kjær measurement accelerometers are calibrated at a frequency of 160 Hz at a level of 100 ms^{-2} . The Type 2970 can only be used in the frequency range of 60 to 250 Hz.

In practice it makes little difference at what level or frequency the accelerometer is calibrated providing they lie well within the normal working range of the accelerometer. After all, accelerometers are extremely linear devices in frequency and dynamic range. In section 2.5.2 it was seen that the charge sensitivity (and capacitance) of Brüel & Kjær general purpose accelerometers employing piezoelectric element PZ 23 and PZ 27 decreases at a rate of 2.5% per decade increase in frequency and therefore this effect can be accounted for if the sensitivity at another frequency is required. For example, the difference from 50 Hz to 160 Hz is approximately 1,3%.

When voltage sensitivities are measured it should be remembered that the voltage sensitivity is only valid for the accelerometer and cable as an integral pair and these are calibrated together. If the cable is changed the calibration is no longer valid.

5.3.4. FFT-based back-to-back calibration

It is possible to perform back-to-back calibration using a Fast Fourier Transform (FFT) approach. By using a Brüel & Kjær Dual Channel Analyzer Type 2032 or 2034 it is possible to apply broad-band noise to the vibration exciter. The outputs of the reference accelerometer and the unknown accelerometer are fed into the two channels of the analyzer. The analyzer computes a frequency response function. After averaging it is possible to produce answers as to the sensitivity and relative phase of the unknown accelerometer over a wide range of frequencies.

As with any calibration set-up, the accuracy of the final calibration depends on the individual accuracies of each of the instruments constituting the set-up, and of the accuracy of the reference accelerometer at all frequencies, including all those which are different from the frequency at which the reference accelerometer was originally calibrated (i.e. 160 Hz). For more details of this technique, contact your local Brüel & Kjær office.

5.3.5. The Use of Calibrated Vibration Exciters for Sensitivity Checking

Perhaps the most convenient and commonly used checking technique is the application of a calibrated vibration exciter. Brüel & Kjær produce an instrument specifically for this purpose. The method can be used by anybody making vibration measurements.

Calibration Exciter Type 4294. This small, pocket-sized and battery-powered instrument is simply a calibrated vibration exciter which provides a fixed acceleration level of 10 ms^{-2} RMS at 159,2 Hz (1000 rads/s) corresponding to an RMS velocity of 10 mms^{-1} and an RMS displacement of $10 \mu\text{m}$. The accuracy is better than $\pm 3\%$. It is ideal for system checking in the field. Fig. 5.11 shows the Type 4294 being used to check the sensitivity of an accelerometer using a measuring amplifier.

The Type 4294 can be used in two ways;

1. Accelerometer sensitivity checks.
2. System calibration checks and adjustment.

Accelerometer sensitivity checking is simply a matter of attaching the accelerometer to the exciter head and measuring the output from the preamplifier to which the accelerometer is attached. This can be achieved by using a good voltmeter.

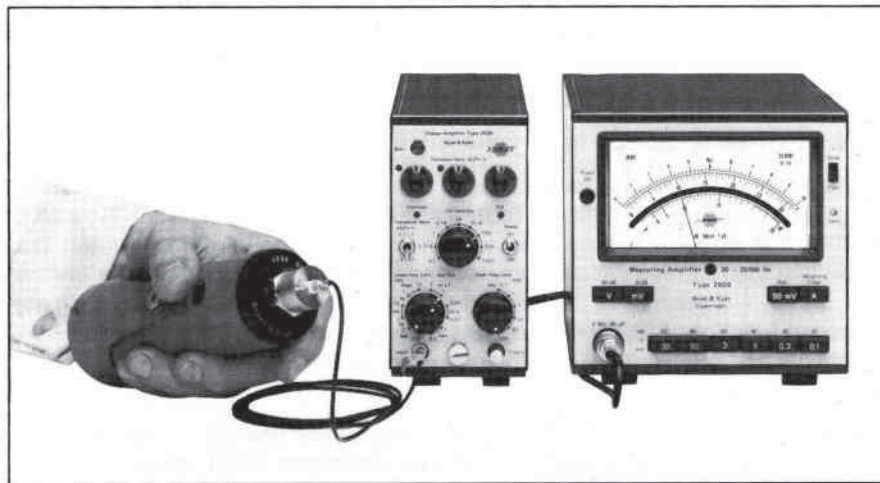

Fig. 5.11. The Calibration Exciter Type 4294

An attractive feature of the Type 4294 is its ability to calibrate an entire measurement chain from accelerometer to analyzer. The overall system sensitivity can be measured regardless of the individual sensitivities of the instruments in the measurement chain.

In addition the gain can be adjusted on one of the instruments to give a full scale deflection corresponding to the reference acceleration produced by the exciter.

5.4. MEASUREMENT OF OTHER ACCELEROMETER PARAMETERS

Accelerometer sensitivity is the most commonly used measured parameter. It is, however, by no means the only parameter most commonly measured for the accurate measurement of vibration. We may wish to have individually measured information on the following:

1. Transverse sensitivity
2. Frequency response
3. Mounted resonance frequency
4. Capacitance

Most of these parameters are individually measured for each individual accelerometer produced by Brüel & Kjær.

The measurement of environmental parameters is covered in section 5.5

5.4.1. Transverse Sensitivity

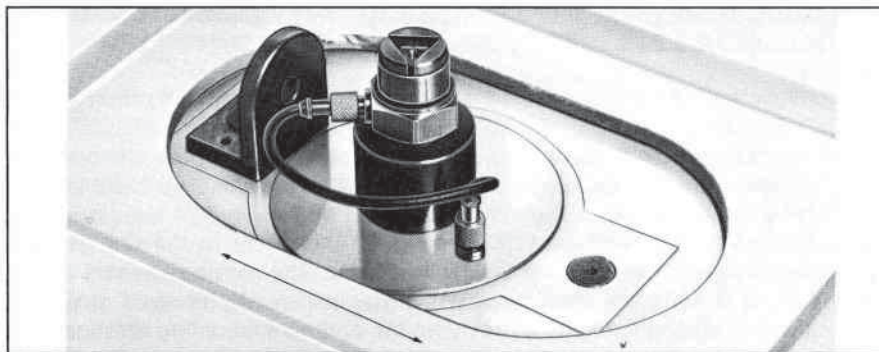

Fig. 5.12. A special exciter similar to this is used at Brüel & Kjær to measure the transverse sensitivity of an accelerometer

At Brüel & Kjær transverse sensitivity is measured by using a special custom-built vibration table similar to that shown in Fig. 5.12. The platform onto which the accelerometer is mounted is vibrated in the horizontal plane at an acceleration of 100 ms^{-2} and at a frequency of 30 Hz. At the same time the accelerometer mounting platform at the centre of the table slowly rotates. This alters the direction of the transverse vibration applied to the accelerometer. The output of the accelerometer is measured and the maximum transverse sensitivity can be found. The direction of the minimum transverse sensitivity is also determined and is indicated by a red dot on most Brüel & Kjær accelerometers.

5.4.2. Frequency Response

Fig. 5.13 shows a set-up similar to that used at Brüel & Kjær for the measurement of the frequency response of all measurement accelerometers except for the miniature types.

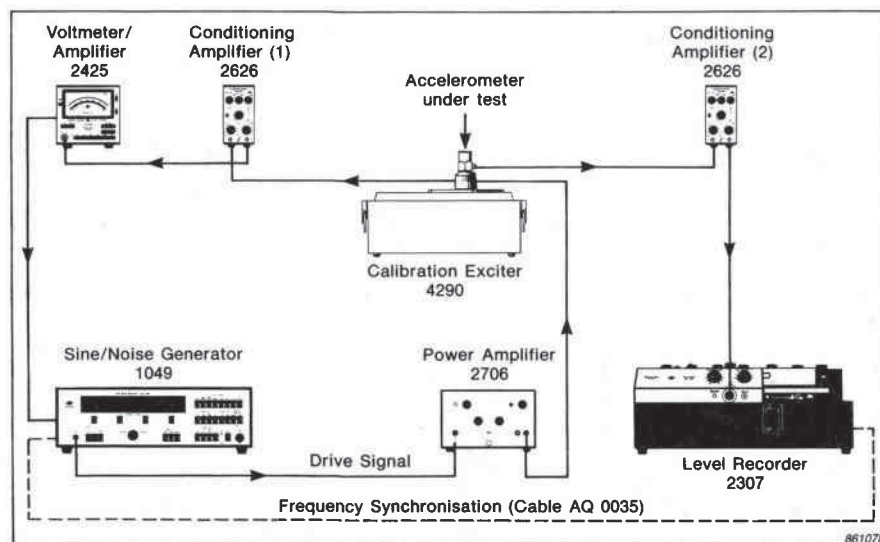

Fig. 5.13. A set-up to measure the frequency response of an accelerometer

The Calibration Exciter Type 4290 (see Fig. 5.14) is driven by the sine generator over a frequency range from 200 Hz to 50 kHz. The moving element of the Type 4290 is a 180 gram steel head which has a carefully finished mounting surface with a tapped fixing hole providing the optimum mounting arrangement for the accelerometer.

The acceleration at the table is kept constant over the frequency range by



Fig. 5.14. The Calibration Exciter Type 4290

means of a feedback signal (compressor loop). A miniature accelerometer built into the exciter head provides a signal relating to the actual acceleration. This signal is fed into the compressor section of the generator where it is used to regulate the output level of the generator automatically so that constant acceleration is obtained at the exciter head. The output from the accelerometer to be calibrated is then passed through a preamplifier and to a level recorder.

Apart from the miniature types and Type 8310, each Brüel & Kjær accelerometer is supplied with an individual frequency response curve recorded in this manner. The mounted resonance frequency stated on the calibration chart can be identified from this curve. By knowing the response of the accelerometer at any particular frequency one is no longer limited to rigid frequency limits

The following points should be remembered when measuring the frequency response of an accelerometer using this technique:

1. The mounting of the accelerometer onto the exciter head is critical. Poor mounting can result in misleading errors in the frequency response curve. For further details consult section 4.4

2. Constant acceleration of the exciter head is not possible unless there is sufficient gain in the feedback (compressor) loop. It is advisable to check that the acceleration of the exciter head is constant over the frequency range of the measurement. This is done by feeding the output of the control accelerometer into the level recorder via its preamplifier and adjusting the preamplifier gain and generator compressor speed accordingly. This method is described in the Instruction Manual for the sine generator or exciter control in use.
3. Over 30kHz the accuracy with which the compressor maintains a constant acceleration at the exciter head decreases rapidly. However, the range up to 50kHz still gives a reliable check of the mounted resonance frequency.

5.4.3. Undamped Natural Frequency

This parameter has little practical use in vibration measurements. Nevertheless it is quoted on the calibration chart because it is a fundamental accelerometer parameter. There are two alternative methods for measuring it.

The accelerometer is suspended by its cable and is excited electrically from a voltage source coupled through a 1 nF capacitor. The undamped natural frequency is defined as that frequency at which the voltage and the current in the accelerometer are in phase. An approximation of this is obtained by monitoring both the voltage across the capacitor and across the accelerometer and finding the frequency where there is a 90° phase difference between the two. This is

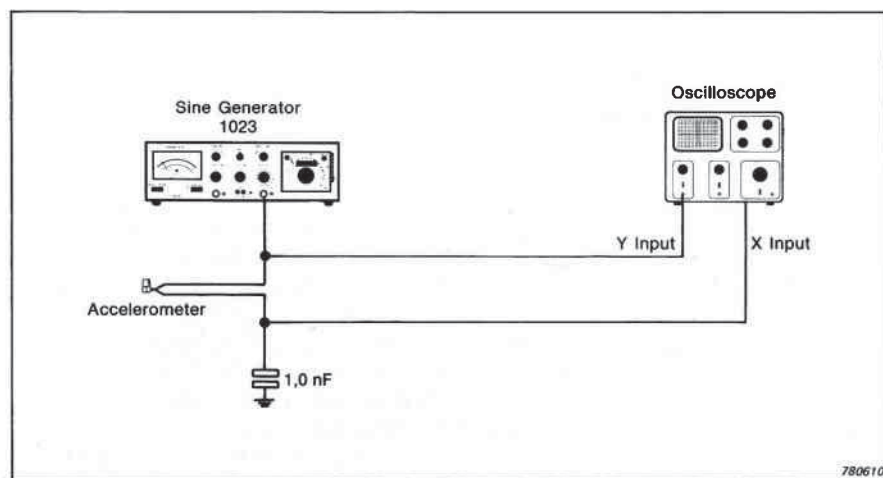

Fig. 5.15. A set-up for the measurement of the undamped natural frequency of an accelerometer

most easily done using a set-up similar to the one shown in Fig. 5.15 where an oscilloscope is used to simultaneously monitor both these quantities. By adjusting the excitation frequency a circular Lissajous figure is formed when the correct frequency has been found.

In the second method the accelerometer is once again suspended by its cable, but this time it is given a mechanical shock by tapping its base. The accelerometer signal is fed via a charge amplifier into a storage oscilloscope where a trace of the decaying oscillations is obtained. By measuring the period of one oscillation in this response and taking its reciprocal, the undamped natural frequency is obtained.

5.4.4. Capacitance

The capacitance of an accelerometer can be defined as the ratio of its charge sensitivity to its voltage sensitivity and can be calculated from these two calibrations. This is how the value on the calibration chart is obtained.

If the capacitance is measured at a frequency of 1000 Hz with a capacitance bridge, a different value to the one calculated in the first paragraph is found. This is caused by the capacitance decrease of 2,5% per frequency decade for piezoelectric elements. The measurement voltage may also be different.

The typical capacitance noted on the calibration chart includes the effect of any cable supplied for use with, or as an integral part of, the accelerometer. To calculate the capacitance of the accelerometer alone it is necessary to subtract the effect of the cable capacitance. A typical value for the cable capacitance can be found on the calibration chart.

5.5. DETERMINATION OF THE EFFECTS OF THE ENVIRONMENT ON THE ACCELEROMETER SPECIFICATIONS

The accelerometer calibration chart has a section giving details on the sensitivity of the accelerometer to environmental phenomena. This section deals with the methods Brüel & Kjær use to determine these sensitivities.

5.5.1. Temperature Transient Sensitivity

This is measured by mounting the accelerometer on an aluminium block whose mass is approximately ten times that of the accelerometer and slowly lowering the combination into a container containing water at a temperature of approximately 25° C greater than the room temperature. Care is taken not to induce any vibration in the set-up.

The preamplifier is set to give a lower limiting frequency of 3 Hz, with a 6 dB/octave roll-off. The peak output from the accelerometer is measured on a storage oscilloscope. The acceleration required to produce this output is calculated from the sensitivity of the accelerometer and divided by the temperature change to obtain the temperature transient sensitivity.

5.5.2. Temperature Sensitivity

If a measurement accuracy better than 1 or 2 dB is required when making vibration measurements at temperatures significantly removed from room temperature, it is advisable to use the information given on the Calibration Chart to obtain a correction factor for the sensitivity of an accelerometer. The information is provided in the form of a graph of the change in sensitivity and capacitance from the values obtained at the calibration temperature (room temperature). Voltage, charge sensitivity and capacitance all vary with temperature.

For Brüel & Kjær accelerometers, individual calibration of temperature dependence is unnecessary because piezoelectric materials of the same type will have similar dependencies. The temperature curves can then be obtained from batch tests and preprinted on all the calibration charts for accelerometers of the same type.

To measure the temperature dependence, the accelerometer is mounted on a special vibration exciter incorporating a push rod which passes into an environmental chamber. The accelerometer to be calibrated is mounted on a table fitted to the end of the rod inside the chamber, and the exciter and reference accelerometer are attached to the other end of the rod, outside the chamber. The table used at Brüel & Kjær can accommodate up to twenty accelerometers (depending on their size). Calibration is performed at a low frequency so there is no risk of inaccuracies caused by resonance in the rod or table. The measurement of temperature dependence is a time-consuming procedure because it is essential to allow sufficient time for the accelerometers to reach equilibrium temperature. There must be no thermal gradients which would otherwise modify the sensitivities.

When this technique is used, the temperature dependence of accelerometer capacitance may be deduced from that of the voltage and charge sensitivities.

5.5.3. Base Strain Sensitivity

Base strain sensitivity is measured by mounting the accelerometer near the fixed end of a heavy steel cantilever beam. Strain gauges are attached to the beam around the accelerometer. The beam is given a displacement at the free end and the accelerometer base is stressed by this motion. The output from the

strain gauges is monitored on a storage oscilloscope along with the accelerometer output. When the strain falls to a level of $250 \mu\epsilon$ the accelerometer output is measured and the acceleration required to produce an equivalent output is calculated. This acceleration is divided by the strain and the base strain sensitivity is obtained. A typical value is given on each calibration chart.

5.5.4. Acoustic Sensitivity

It is difficult to accurately measure the acoustic sensitivity of an accelerometer without mechanical interference from the acoustic actuator producing misleading results. At Brüel & Kjær the accelerometer is mounted inside a special chamber which is rigidly secured to a high pressure microphone calibrator which produces a sound pressure level of 154 dB inside the chamber. This arrangement ensures that the minimum possible vibration is transmitted to the accelerometer.

The output from the accelerometer and its preamplifier is passed through a frequency analyzer and the calibrator is excited with a swept frequency sine wave. From the spectrum of the accelerometer output it is possible to determine which part of the signal is due to the acoustic excitation and which is due to the vibration transmitted from the piston of the actuator. The latter will normally mask the former at frequencies above 100 Hz which is why the acoustic sensitivity specification is only quoted in the 2 to 100 Hz band. However, the results are estimated to be valid up to frequencies of several kilohertz. At these high frequencies the wavelengths are comparable to the dimensions of the accelerometer.

5.5.5. Magnetic Sensitivity

This is also a difficult parameter to measure accurately. At Brüel & Kjær the accelerometer is placed in the centre of a large coil and an alternating magnetic field is created by passing 50 Hz mains through the coil. In the centre of the coil the field strength is 0,03 T. The accelerometer is rigidly fixed to a heavy support so that electromagnetically induced motion of the accelerometer and fixing is minimized. The output from the accelerometer is measured and converted to a sensitivity as in the examples above. The following points are considered.

1. The induction of a current in the clamping ring around the elements is unavoidable. This current will react with the magnetic field and the ring, and the piezoelectric elements to which it is secured, will move.
2. There will be some induced motion of the seismic masses because they will have some magnetic permeability, however small it may be.
3. Currents will be induced in the accelerometer cable.

As it is not possible to isolate the individual contributions of these effects, the cumulative effect is taken and used to derive the magnetic sensitivity.

5.5.6. Temperature Limits

Temperature limits are defined as the maximum and minimum temperatures at which it is possible to use the accelerometer. There must not be more than a small and well defined change in any calibration parameter after the accelerometer has had 24 hours to "recover" at room temperature.

At Brüel & Kjær this is achieved simply by heating the accelerometer in an oven or cooling it in a freezer. When it is taken out again a full check of the calibration is performed after 24 hours. A 2% change in sensitivity is allowed.

5.5.7. Shock Limits

Shock limits are determined by mounting the accelerometer on a hydraulic machine which strikes the accelerometer one hundred times in short succession at a known shock level. This is repeated in all 3 axes of the accelerometer (x,y and z) and a calibration of sensitivity and frequency response is then made. The maximum shock is taken as the lowest shock in any axis which causes more than a 2% change in sensitivity .

The shock limits are measurement limits provided that the preamplifier used with the accelerometer can accommodate the very high input charge presented to it by the accelerometer. In the rare case that a high sensitivity accelerometer is used to measure shock, the accelerometer output can be reduced using a charge attenuator. See section 3.2.4.

5.6. FACTORY TESTING OF ACCELEROMETER CABLES

Fig. 5.16 shows a set-up similar to that used at Brüel & Kjær to test the low noise performance of accelerometer cables. The cable is terminated by a load which represents a general purpose accelerometer and one end is subjected to a preloading force. The output from the cable is fed into a charge preamplifier. The cable is then connected between the two end supports and its centre is clamped onto a shaker. The cable is excited, using narrow band random vibration centred around 80 Hz. The output of the cable is measured. If a cable is too noisy it is rejected. At Brüel & Kjær every AO 0038 cable is individually tested. All other cables are batch tested.

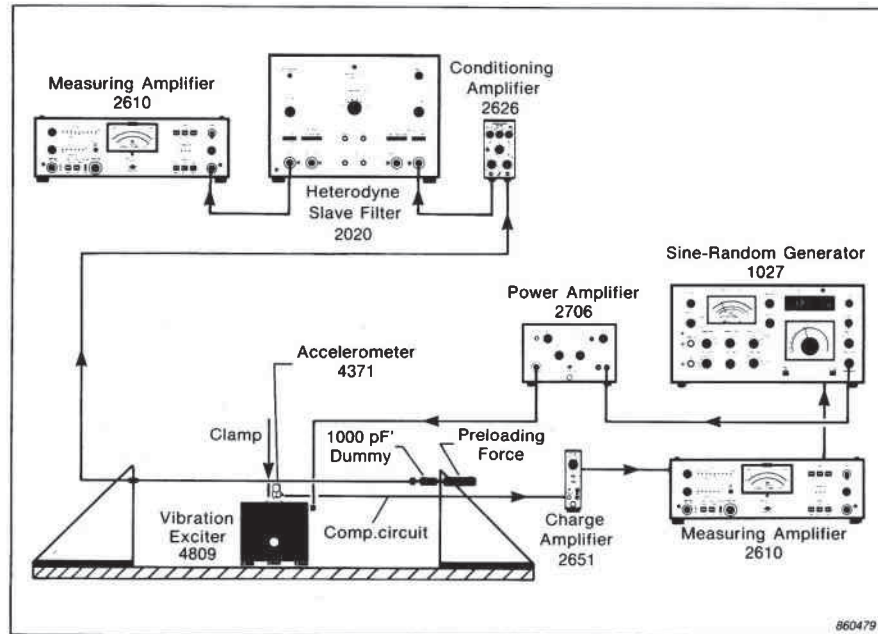

Fig. 5.16. Measurement of triboelectric noise in accelerometer cables

5.7. CALIBRATION EQUIPMENT

5.7.1. Calibration System Type 9559

This is a complete specialized system for the calibration of both accelerometers and microphones. Equipped with such a system, a laboratory can calibrate sensitivity and frequency parameters, enabling them to issue calibration certificates. The system is shown in Fig. 5.17

Such a system is used at several Brüel & Kjær service centres throughout the world and is available to any organization wishing to perform calibrations. Each system comes complete with a step-by-step guide for the calibration of both accelerometers and microphones. For more details on the Type 9559 contact your local Brüel & Kjær representative.

5.7.2. Individual Calibration Equipment

Fig. 5.18 gives a summary of the calibration equipment available from Brüel & Kjær which is mentioned in this chapter.



Fig. 5.17. The Calibration System Type 9559

5.8. STANDARDS RELATING TO THE CALIBRATION OF ACCELEROMETERS

At Brüel & Kjær the wide range of accelerometer calibrations and tests comply with ISO 5347-“Methods for the Calibration of Vibration and Shock Pick-ups”. This paper contains outlines of the techniques which are recommended for the various calibrations of accelerometers and should be consulted for further details.





Other standards relating to calibration are;

ANSI S2.11-1969-“The selection of calibrations and tests for electrical transducers used for measuring shock and vibration”

ISO/DP 8042-“Characteristics to be specified for seismic transducers for shock and vibration measurements”

British Calibration Service Guidance Document No. 3003

134

<p>Type 4290 Calibration Exciter</p> 	<p>Small vibration exciter for use in accelerometer frequency response measurements. Used with B & K Sine Generators.</p> <ul style="list-style-type: none"> ■ Max. force level 3N. Frequency Range 200 Hz to 50 kHz ■ Built-in accelerometer for level regulation of generator
<p>Calibration Head Type 4815</p> 	<p>Primarily intended for high acceleration calibration of accelerometers and other measuring transducers using back-to-back and laser interferometer methods</p> <ul style="list-style-type: none"> ■ Built-in Standard Reference Accelerometer Type 8305 ■ Fits Exciter Body Type 4801 or Permanent Magnet Body Type 4805 ■ Accelerometer Calibration possible over a frequency range from 5 Hz to 10 kHz
<p>Type 2970 Sensitivity Comparator</p> 	<p>Rapid back to back comparison calibration of accelerometers. Used together with Calibration Set Type 3506 and Precision Conditioning Amplifier Type 2650.</p> <ul style="list-style-type: none"> ■ Calibration accuracy $\pm 1,02\%$ at 99% confidence level
<p>Type 4294 Calibration Exciter</p> 	<p>Pocket-size vibration reference source for calibration of accelerometers or measuring systems.</p> <ul style="list-style-type: none"> ■ Fixed RMS level $10 \text{ ms}^{-2} \pm 3\%$ at 159,2 Hz (1000 rad/s) ■ Internal batt. supply (1 \times IEC 6LF22)
<p>Type 3506 Calibration Set</p> 	<p>Consists of Reference Accelerometer Type 8305 plus Conditioning Amplifier Type 2626 calibrated as integral pair using laser interferometry method. For use in accelerometer calibration set-ups.</p>

T01019GB0

Fig. 5.18. A summary of calibration equipment available from Brüel & Kjær

6. APPENDICES

APPENDIX A

m	cm	mm	ft	in
1	100	1000	3,281	39,37
0,01	1	10	0,0328	0,3937
0,001	0,1	1	0,00328	0,03937
0,3048	30,48	304,8	1	12
0,0254	2,54	25,4	0,0833	1

T01087GB0

Table 1. Conversion of length

m/s	km/h	ft/min	mile/h
1	3,6	196,85	2,2369
0,2778	1	54,68	0,6214
$5,08 \times 10^{-3}$	$1,829 \times 10^{-2}$	1	$1,136 \times 10^{-2}$
0,4470	1,6093	88	1

T01088GB0

Table 2. Conversion of velocity

g	m/s ²	cm/s ²	ft/s ²	in/s ²
1	9,81	981	32,2	386
0,102	1	100	3,281	39,37
0,00102	0,01	1	0,0328	0,3937
0,03109	0,3048	30,48	1	12
0,00259	0,0254	2,54	0,0833	1

T01089GB0

Table 3. Conversion of acceleration

kg	tekma	gram	lbs	oz
1	0,102	1000	2,2046	35,274
9,807	1	9807	21,6205	345,93
10^{-3}	1,02 10^{-4}	1	2,205 10^{-3}	3,527 10^{-2}
0,45359	4,625 10^{-2}	453,59	1	16
2,835 10^{-2}	2,8908 10^{-3}	28,35	6,25 10^{-2}	1

T01091GB0

Table 4. Conversion of weight (mass)

N	kp	lb ft/s ²
1	0,102	7,2329
9,807	1	71,0
0,1379	1,405 10^{-2}	1

T01090GB0

Table 5. Conversion of force

N/m ²	mbar	mm H ₂ O	atm	in WG	psi
1	10^{-2}	0,102	9,869 10^{-6}	4,02 10^{-3}	1,4505 10^{-4}
100	1	10,917	9,868 10^{-4}	0,402	1,4504 10^{-2}
9,807	9,807 10^{-2}	1	9,678 10^{-5}	3,937 10^{-2}	1,4223 10^{-3}
1,013 10^5	1013	1,0332 10^4	1	406,77	14,696
249,10	2,491	25,4	2,453 10^{-3}	1	3,605 10^{-2}
6908,9	69,089	704,49	6,805 10^{-2}	27,736	1

T01092GB0

Table 6. Conversion of pressure

J = Ws	kWh	kpm	kcal	Btu	ft lb
1	2,778 10 ⁻⁷	0,1020	2,39 10 ⁻⁴	9,48 10 ⁻⁴	0,7376
3,6 10 ⁶	1	3,6710 10 ⁵	860	3413	2,655 10 ⁶
9,807	2,7241 10 ⁻⁶	1	2,3423 10 ⁻³	9,2949 10 ⁻³	7,233
4187	1,163 10 ³	427	1	3,9685	3087,4
1056	2,93 10 ⁴	107,59	0,25198	1	778
1,3558	3,766 10 ⁻⁷	0,1383	3,239 10 ⁻⁴	1,285 10 ⁻³	1

T01094GB0

Table 7. Conversion of work, energy and heat

kW	kpm/s	hk	kcal/h	ft lb/s	hp
1	102	1,36	860	738	1,34
9,81 10 ⁻³	1	1,33 10 ⁻²	8,44	7,23	1,32 10 ⁻²
0,735	75	1	632	542	0,986
1,16 10 ⁻³	0,119	1,58 10 ⁻³	1	0,858	1,56 10 ⁻³
1,36	0,138	1,84 10 ⁻³	1,17	1	1,82 10 ⁻³
0,745	76	1,014	642	550	1
2,93 10 ⁻⁴	2,99 10 ⁻²	3,99 10 ⁻⁴	0,252	0,216	3,93 10 ⁻⁴
3,52	35,9	0,479	3024	259	0,471

T01096GB0

Table 8. Conversion of power

Symbol	Prefix	Multiple
G	giga	10 ⁹
M	mega	10 ⁶
k	kilo	10 ³
c	centi	10 ⁻²
m	milli	10 ⁻³
μ	micro	10 ⁻⁶
n	nano	10 ⁻⁹
p	pico	10 ⁻¹²

T01235GB0

Table 9. Commonly used prefixes

APPENDIX B

VIBRATION NOMOGRAM

The vibration nomogram is a graphical description of the relationship between frequency, displacement, velocity and acceleration for simple harmonic vibrations. If any two parameters are known the other two can be simply read off the chart.

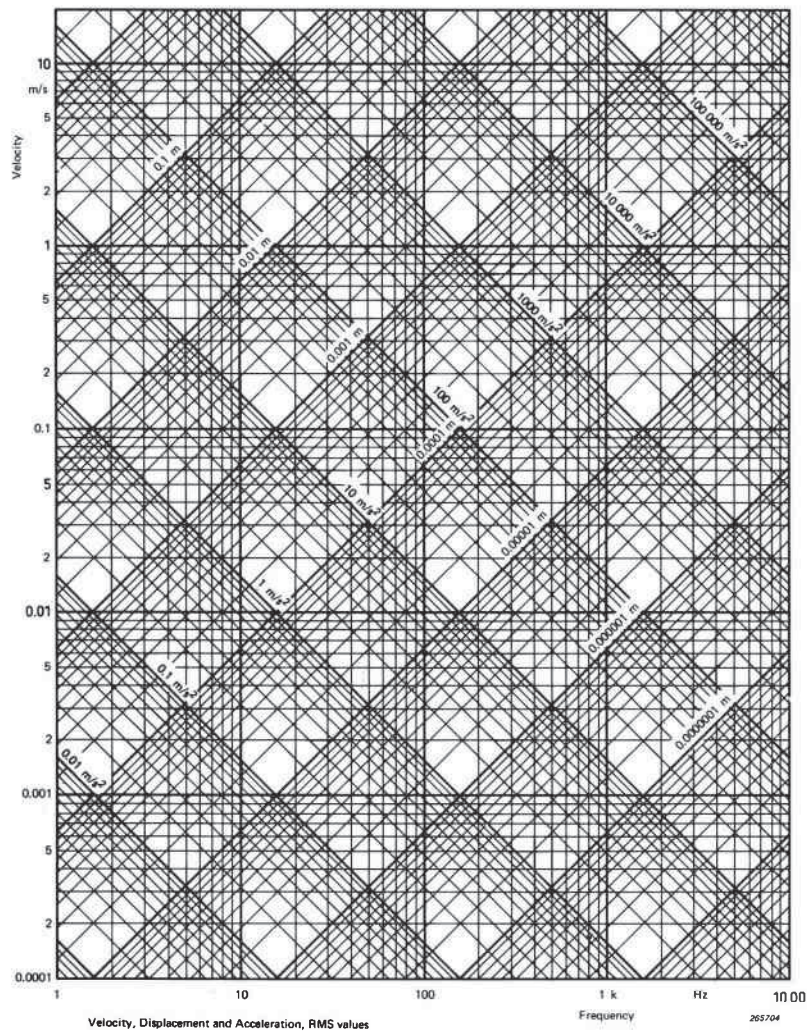

APPENDIX C

VIBRATION STANDARDS

Due to the continuously evolving nature of standards and the variety of standards around the world, the inclusion of a set of relevant standards would have limited value. However, Brüel & Kjær have a publication "National and International Standards and Recommendations-Acoustics, Vibration & Shock, Luminance and Contrast" which is available from your local Brüel & Kjær representative agent. A selection of the main standards in this area published by every standard authority in the world are included along with the addresses of the authorities.

APPENDIX D

BRÜEL & KJÆR VIBRATION LITERATURE

Brüel & Kjær produce a large number of technical education publications in the field of vibration. They are divided up into the following categories:

Primers. These A5 size basic texts offer a simplified introduction into the theory and application of a selected subject area. In the field of vibration there are presently three primers; Measuring Vibration, Vibration Testing and Machine Health Monitoring. All three are available from your local Brüel & Kjær representative.

Application Notes. These short papers are published regularly and concentrate on the application of Brüel & Kjær equipment to a particular area of current interest.

Technical Review. This is published four times a year and deals with the application of Brüel & Kjær instruments and special developments which the company may consider of interest to customers.

Books. Several books on vibration are available from Brüel & Kjær. Here is a selection;

“Mechanical Vibration and Shock Measurements”

“Frequency Analysis”



“Modal Testing – Theory and Practice”



“Modal Analysis of Large Structures”

A list of current Application Notes and Technical Reviews is available on request.

APPENDIX E

Summary of preamplifiers currently available from Brüel & Kjær. The Line-drive Amplifier Type 2644 is covered in Chapter 3. For more information consult the Product Data Sheets on these types

Preamplifier Type	2635  3-digit sensitivity conditioning, low noise charge amplifier	2626  3-digit sensitivity conditioning, low noise charge amplifier
Measurement Modes	Acceleration Velocity Displacement	Acceleration
Amplifier Sensitivity	0,1 mV to 10 V/pC (-20 to + 80 dB)	0,1 mV to 1 V/pC (-20 to + 60 dB)
Frequency Range (-3 dB limits)	0,1 Hz to 200 kHz	0,3 Hz to 100 kHz
Selectable Frequency Limits (-3 dB limits)	Low	0,2; 1; 2; 10 Hz (10% limits)
	High	0,1; 1; 3; 10; 30; > 100 kHz (10% limits)
Power Supply	Internal batteries or Ext. DC	AC Mains
Other Features	Overload indicator. Test oscillator. Battery condition indicator	Overload indicator. Direct and transformer coupled outputs
Applications	Field measurement of vibration. Underwater sound measurement with Hydrophones	General purpose measurements. Comparison calibration of accelerometers

 <p>2651</p> <p>3-Uni-Gain sensitivity settings. Charge amplifier. Very low frequency measurement capability</p>	 <p>2634</p> <p>Small, robust, adjustable gain, charge amplifier. Excellent electromagnetic radiation immunity</p>	 <p>2650</p> <p>4 digit sensitivity conditioning. Low noise charge and voltage amplifier</p>
Acceleration Velocity	Acceleration	Acceleration
0,1–1–10 mV/pC (–20 to + 20 dB)	0,9 to 10 mV/pC internally adjustable (0 to 20 dB)	0,1 mV/pC to 100 mV/pC. 100 mV/V (–20 to + 40 dB)
0,003Hz to 200 kHz	1 Hz to 200 kHz	0,3 Hz to 200 kHz
0,003; 0,03; 0,3; 1 Hz	—	0,3; 3 Hz; 2 kHz
200 kHz	—	1; 3; 10; 30; > 200 kHz
Ext. DC	Ext. DC	AC Mains
Input signal- ground floating or grounded	Normal or differential input. Can be fixed to machine frames	Overload indicator Test oscillator
Multi-channel measurements shock measurements	Vibration measurements in industrial environments Permanent installations	Comparison calibration of accelerometers. General measurements

T00869GB1

APPENDIX F

Accelerometers can be connected directly to these instruments. For more details consult the Product Data Sheets on these types

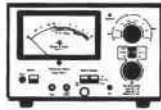
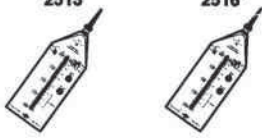
Instrument Type	2511  Vibration Meter	2513 2516³  Integrating Vibration Meters
Description	A versatile vibration meter for general vibration measurement	Economical and accurate vibration meters for day-to-day use
Measurement Modes	acceleration, velocity displacement	acceleration, velocity
Frequency range (-3dB)	0,3 Hz to 15 kHz	10 Hz to 10 kHz ¹
Selectable frequency limits (-3dB)	LLF 1,3 and 10 Hz ¹ ULF 1 and 15 kHz ²	LLF ² 8 Hz and 10 Hz ULF ² 1 kHz and 10 kHz
Detectors	RMS True Peak-to-Peak	One minute L _{eq} RMS, Max. Peak
Power Supply	Internal battery external DC	Internal battery
Input	Charge	Charge
Notes	<ol style="list-style-type: none"> 1. 0,3 Hz and 3 Hz for acceleration mode 2. With 1 kHz Selected the 2511 can be used in vibration severity measurements 	<ol style="list-style-type: none"> 1. When linear weighting is selected 2. Related to linear, Hand-Arm and Vibration Severity measurements (ISO/DP 5349 and ISO 2954) 3. 2513 uses SI units. 2516 uses imperial. 2513/WH 2134 is a simplified version of these Instruments

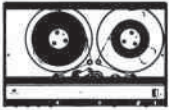
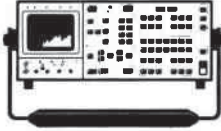
<p style="text-align: center;">7007 ZM 0060</p>  <p style="text-align: center;">Tape Recorder</p>	<p style="text-align: center;">2515</p>  <p style="text-align: center;">Vibration Analyzer</p>
<p>A fully portable instrument for field and laboratory recording of vibration and sound data using plug-in module ZM 0060</p>	<p>A powerful FFT analyzer for machine vibration analysis, including machine health monitoring, fault diagnosis and balancing</p>
<p>acceleration, velocity</p>	<p>acceleration, velocity, displacement (analogue)</p>
<p>0,3 Hz to 16 kHz¹</p>	<p>0,3 Hz to 20 kHz (-1 dB)¹</p>
<p>LLF 0,3, 1 and 10 Hz —</p>	<p>LLF 0,3 Hz or 3 Hz ULF up to 8 selectable, depending on analysis mode</p>
<p>—</p>	<p>Total RMS in addition to many frequency analysis options.</p>
<p>Plug-in battery box external DC</p>	<p>Internal battery, external DC</p>
<p>Charge</p>	<p>Charge, Voltage, Line-drive</p>
<p>1. Depends on tape speed</p>	<p>1. The following facilities are available: Constant Percentage Bandwidth analysis (6% and 23%), Narrow Band Analysis, Zoom Analysis, Scan Analysis, Cepstrum Analysis, Speed Compensation, Spectrum Comparison, Mass Storage</p>

T00943GB1

APPENDIX G

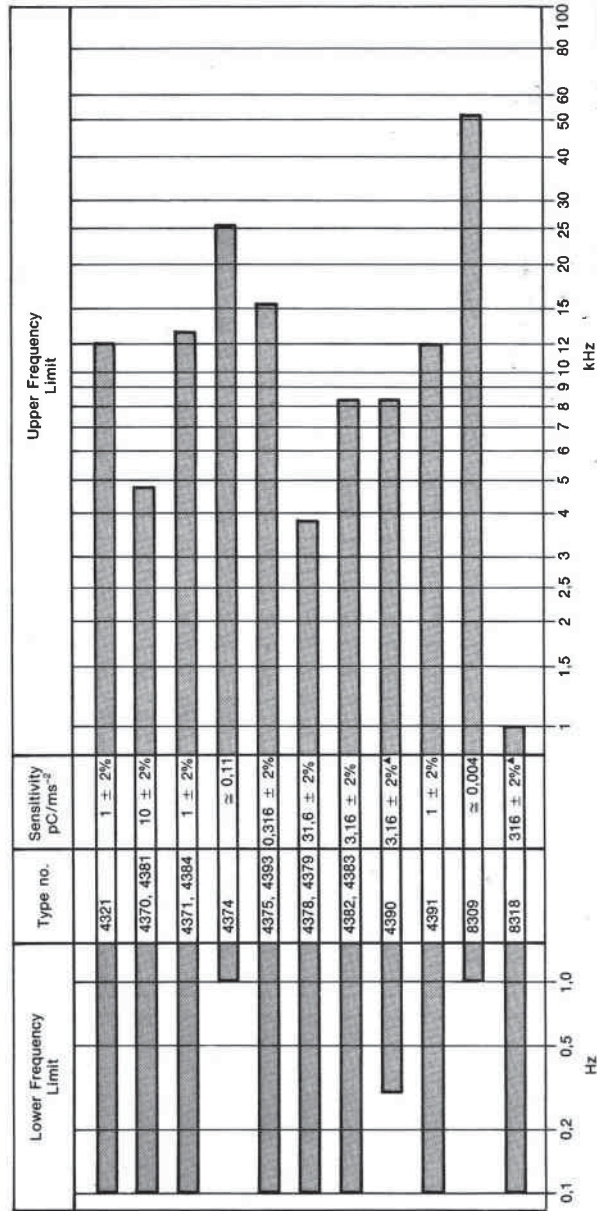

Upper and lower frequency limits (10%) and sensitivities of the general purpose accelerometers. ▲ denotes a line-drive type where the sensitivity is given in $\mu\text{A}/\text{ms}^{-2}$.

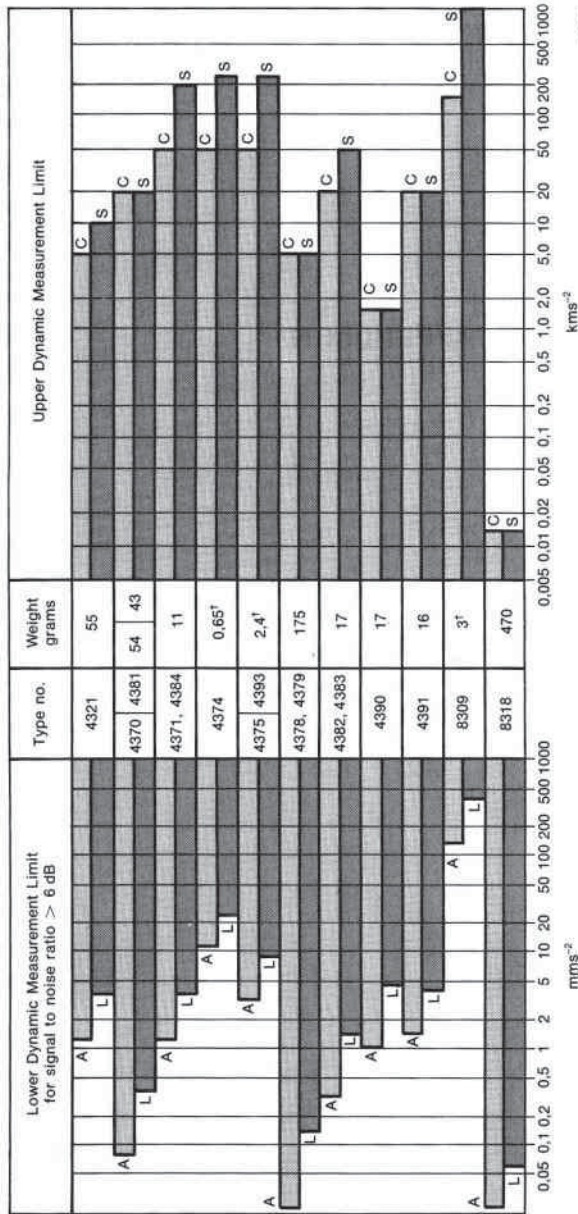

Upper and lower dynamic measurement limits and weights of the accelerometers. Maximum limits (C= continuous sinusoidal vibration and S= shock) are peak values. Minimum limits (A= 1/3 octave bandwidth up to individual accelerometer +10% upper frequency limit and L= Lin 2 Hz to 22kHz) are RMS values. The dynamic limits are typical measurable vibration levels using the accelerometers and Brüel & Kjær Charge Amplifier Type 2635. † denotes cable weight excluded.

APPENDIX H

150

Type	Weight (grams)	Sensitivity		Frequency Range + 10% Limit (kHz)	Notable Characteristics	Application Areas
		Voltage mV/ms ⁻² (mV/g)	Charge pC/ms ⁻² (pC/g)			
4374	0,65 (excluding cable)	≈ 0,18 (≈ 1,8)	≈ 0,11 (≈ 1,1)	26	Miniature Shear Type with extremely low weight and high resonance frequency Integral cable. Uni-Gain [®] sensitivity	High level and high frequency vibration measurements Shock measurements Vibration measurements on delicate structures and in confined spaces
4393	2,4	≈ 0,48 (≈ 4,8)	0,316 ± 2% (3,10 ± 2%)	16,5	Miniature Delta Shear [®] Type with low weight and high resonance frequency	
4375	2,4 (excluding cable)	≈ 0,48 (≈ 4,8)	0,316 ± 2% (3,10 ± 2%)	16,5	Miniature Delta Shear [®] Type with low weight and high resonance frequency. Integral cable	
4391	16	≈ 0,8 (≈ 8)	1 ± 2% (9,81 ± 2%)	12	Delta Shear [®] construction with Uni-Gain [®] sensitivity featuring an insulated base and TNC top connector	Suitable for general shock and vibration measurements
4371	11	≈ 0,8 (≈ 8)	1 ± 2% (9,81 ± 2%)	12,6	Side Connector	
4384	11	≈ 0,8 (≈ 8)	1 ± 2% (9,81 ± 2%)	12,6	Top Connector	
4382	17	≈ 2,6 (≈ 26)	3,16 ± 2% (31,0 ± 2%)	8,4	Top Connector	
4383	17	≈ 2,6 (≈ 26)	3,16 ± 2% (31,0 ± 2%)	8,4	Side Connector	
4390	17	3,16 ± 2% μA/ms ⁻² (31,0 ± 2% μA/g)		8,4	Line-Drive accelerometer with Uni-Gain [®] sensitivity and Delta Shear [®] design	Suitable for general vibration work and also for direct connection to B & K Dual Channel Signal Analyzers
4370	54	≈ 8 (≈ 80)	10 ± 2% (98,1 ± 2%)	4,8	Top Connector	General vibration measurements Higher sensitivity for low level measurements
4381	43	≈ 8 (≈ 80)	10 ± 2% (98,1 ± 2%)	4,8	Side Connector	
4378	175	≈ 26 (≈ 260)	31,6 ± 2% (310 ± 2%)	3,9	Top Connector	Suitable for environments where only low level vibrations are encountered
4379	175	≈ 26 (≈ 260)	31,6 ± 2% (310 ± 2%)	3,9	Side Connector	
8318	470	316 ± 2% μA/ms ⁻² (3100 ± 2% μA/g)		1	Delta Shear [®] design featuring built-in Line-Drive preamplifier and very high sensitivity. Uni-Gain [®] sensitivity	Very low level vibration measurements. Built-in low pass filter gives well defined upper frequency limit
8309	3 (excluding cable)	≈ 0,04 (≈ 0,4)	≈ 0,004 (≈ 0,04)	54	Small size. 5mm integral fixing stud. Integral cable	Shock measurements up to 1 million ms ⁻² . High frequency vibration measurements
4321	55	≈ 0,8 (≈ 8)	1 ± 2% (9,81 ± 2%)	12	Three Delta Shear [®] accelerometers of the same Uni-Gain [®] sensitivity combined into a single unit	For measurements of vibrations in 3 mutually perpendicular directions
4322	350	≈ 0,8 (≈ 8)	1 ± 2% (9,81 ± 2%)	0,1 in rubber pad	Three Delta Shear [®] Uni-Gain [®] type accelerometers mounted in a rubber and metal housing	Type 4322 is used with the Type 2512 Human Response Vibration Meter to measure Whole Body Vibration
8305	40	-	≈ 0,125 (≈ 1,25)	5,3 (2% limit)	Quartz element with very high stability and wide temperature range. Laser calibrated to ± 0,6% accuracy	Reference Standard Accelerometer for back-to-back calibration of accelerometers
8310	100 (excluding cable)	≈ 1,0 (≈ 10)	1 ± 2% (9,81 ± 2%)	9	Integral stainless steel cable and high temperature operation up to 400°C. Uni-Gain [®] sensitivity	Industrial accelerometers designed for use in the most severe environmental conditions often encountered in permanent vibration monitoring situations
8315	102	≈ 2,5 (≈ 25)	10 ± 2% (98,1 ± 2%)	8,1	Electrically balanced and insulated for low noise in strong electromagnetic fields	
8317	112	3,16 ± 2% μA/ms ⁻² (31,0 ± 2% μA/g)		7,5	Built-in Line-Drive amplifier for low noise Safe for use in explosive environments. Uni-Gain [®] sensitivity	

T00720GB1

Summary of accelerometer types currently available from Brüel & Kjær. Consult the latest General Purpose Accelerometers, Industrial Accelerometers and Standard Reference Accelerometer Product Data Sheets for complete details

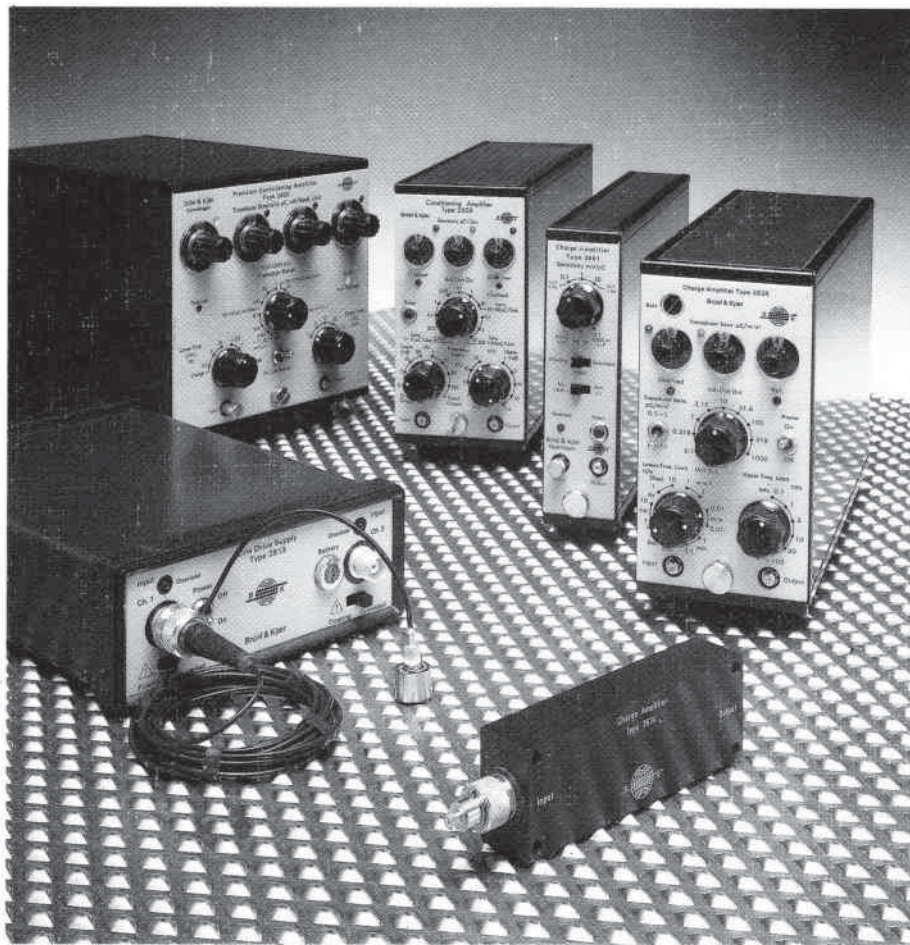

Brüel & Kjær 

DK-2850 Nærum · Denmark · Telephone: +45 280 0500 Telex: 37316 brukda dk

English DK BB0694-12