



US006851711B2

(12) **United States Patent**
Goertzen et al.

(10) **Patent No.:** **US 6,851,711 B2**
(45) **Date of Patent:** **Feb. 8, 2005**

(54) **VEHICLE HAVING AN ANTI-DIVE/LOCKOUT MECHANISM**

(75) Inventors: **Gerald Goertzen**, Brunswick, OH (US); **William A. Null, Jr.**, Sullivan, OH (US)

(73) Assignee: **Invacare Corporation**, Elyria, OH (US)

(*) Notice: Subject to any disclaimer, the term of this patent is extended or adjusted under 35 U.S.C. 154(b) by 0 days.

(21) Appl. No.: **10/643,010**

(22) Filed: **Aug. 18, 2003**

(65) **Prior Publication Data**

US 2004/0094944 A1 May 20, 2004

Related U.S. Application Data

(60) Provisional application No. 60/404,180, filed on Aug. 16, 2002, and provisional application No. 60/421,178, filed on Oct. 25, 2002.

(51) **Int. Cl.**⁷ **B60G 21/10**

(52) **U.S. Cl.** **280/755; 280/754; 280/124.104**

(58) **Field of Search** 280/754, 755, 280/124.104, 124.116, 124.128, 86.1

(56) **References Cited**

U.S. PATENT DOCUMENTS

- 3,174,176 A * 3/1965 Olson 16/35 R
- 3,709,313 A 1/1973 James
- 3,848,883 A 11/1974 Breacain
- 3,876,012 A 4/1975 Regler
- 3,883,153 A * 5/1975 Singh et al. 280/124.104
- 4,341,278 A 7/1982 Meyer
- 4,437,678 A 3/1984 Schultz
- 4,500,102 A 2/1985 Haury et al.
- 4,556,229 A 12/1985 Bihler et al.
- RE32,242 E 9/1986 Minnebraker
- 4,721,322 A 1/1988 Hawkins
- 4,826,194 A * 5/1989 Sakita 285/302

- 4,886,294 A 12/1989 Nahachewski
- 4,934,626 A 6/1990 Kimura
- 5,176,393 A 1/1993 Robertson et al.
- 5,241,876 A 9/1993 Mathis
- 5,290,055 A 3/1994 Treat, Jr.
- 5,294,141 A 3/1994 Mentessi et al.
- 5,316,328 A 5/1994 Bussinger
- 5,351,774 A 10/1994 Okamoto
- 5,467,838 A * 11/1995 Wu 180/209
- 5,513,875 A * 5/1996 Tahara et al. 280/124.162
- 5,531,284 A 7/1996 Okamoto
- 5,575,348 A 11/1996 Goertzen et al.
- 5,611,555 A * 3/1997 Vidal 280/282
- 5,853,059 A 12/1998 Goertzen et al.
- 5,964,473 A * 10/1999 Degonda et al. 280/250.1
- 6,041,876 A 3/2000 Pulver et al.

(List continued on next page.)

FOREIGN PATENT DOCUMENTS

- CA 2254372 * 11/1998
- EP 0677285 A1 10/1995
- EP 0908166 A3 4/1999
- WO WO00/08910 2/2000
- WO WO00/09356 2/2000
- WO WO00/12040 3/2000
- WO WO00/66060 11/2000

Primary Examiner—David R. Dunn
Assistant Examiner—George D Spisich
(74) *Attorney, Agent, or Firm*—Calfee, Halter & Griswold, LLP

(57) **ABSTRACT**

A suspension for a vehicle is provided. The suspension includes, for example, a frame and a releasable locking assembly. The releasable locking assembly has, for example, a first assembly movably coupled to the frame, a second assembly movably coupled to the frame, and wherein movement of the frame relative to the first and second assemblies causes the first and second assemblies to engage each other to limit further movement of the frame in at least a first direction.

80 Claims, 22 Drawing Sheets

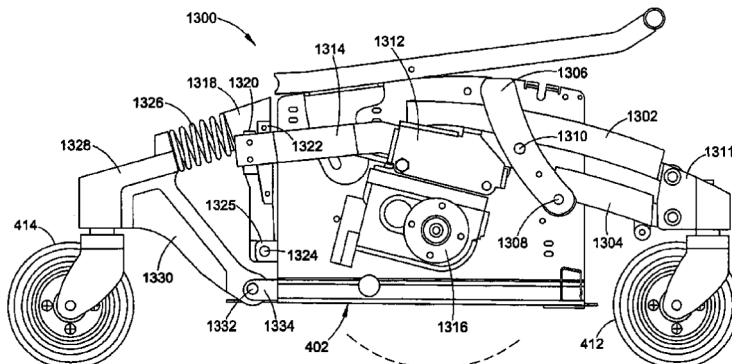

US 6,851,711 B2

Page 2

U.S. PATENT DOCUMENTS

6,070,898	A	6/2000	Dickie et al.						
6,131,679	A	* 10/2000	Pulver et al.	180/65.1	6,460,641	B1	* 10/2002	Kral	180/24.02
6,209,670	B1	* 4/2001	Fernie et al.	180/12	6,533,306	B2	3/2003	Watkins	
6,225,894	B1	5/2001	Kyrtos		6,543,564	B1	4/2003	Kamen et al.	
6,234,507	B1	5/2001	Dickie et al.		6,543,798	B2	4/2003	Schaffner et al.	
6,341,671	B1	1/2002	Ebersole		6,588,799	B1	* 7/2003	Sanchez	280/755
6,347,688	B1	2/2002	Hall et al.		2002/0023787	A1	2/2002	Kamen et al.	
6,405,816	B1	6/2002	Kamen et al.		2002/0175027	A1	11/2002	Usherovich	
					2004/0032119	A1	* 2/2004	Tran et al.	280/755

* cited by examiner

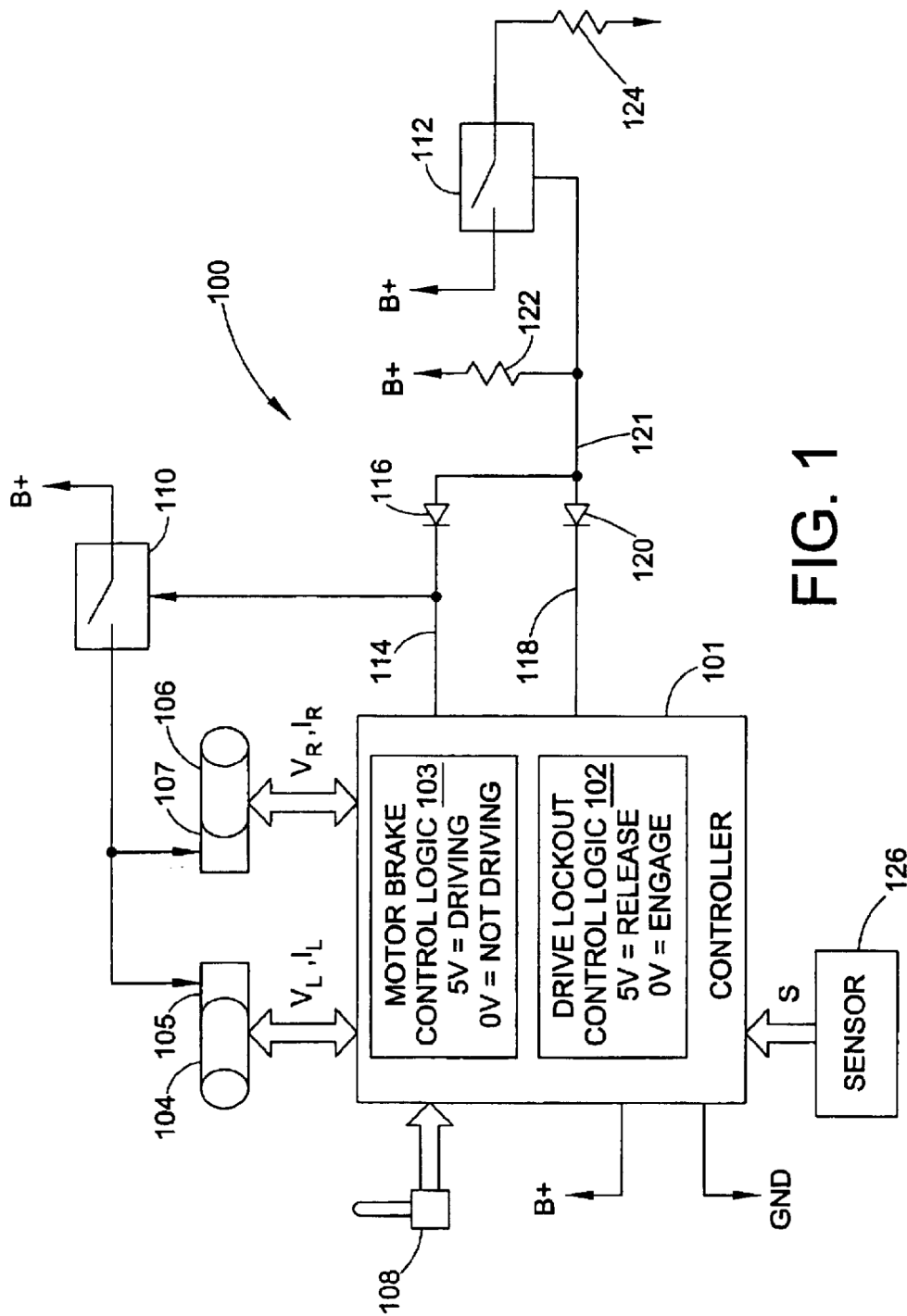

FIG. 1

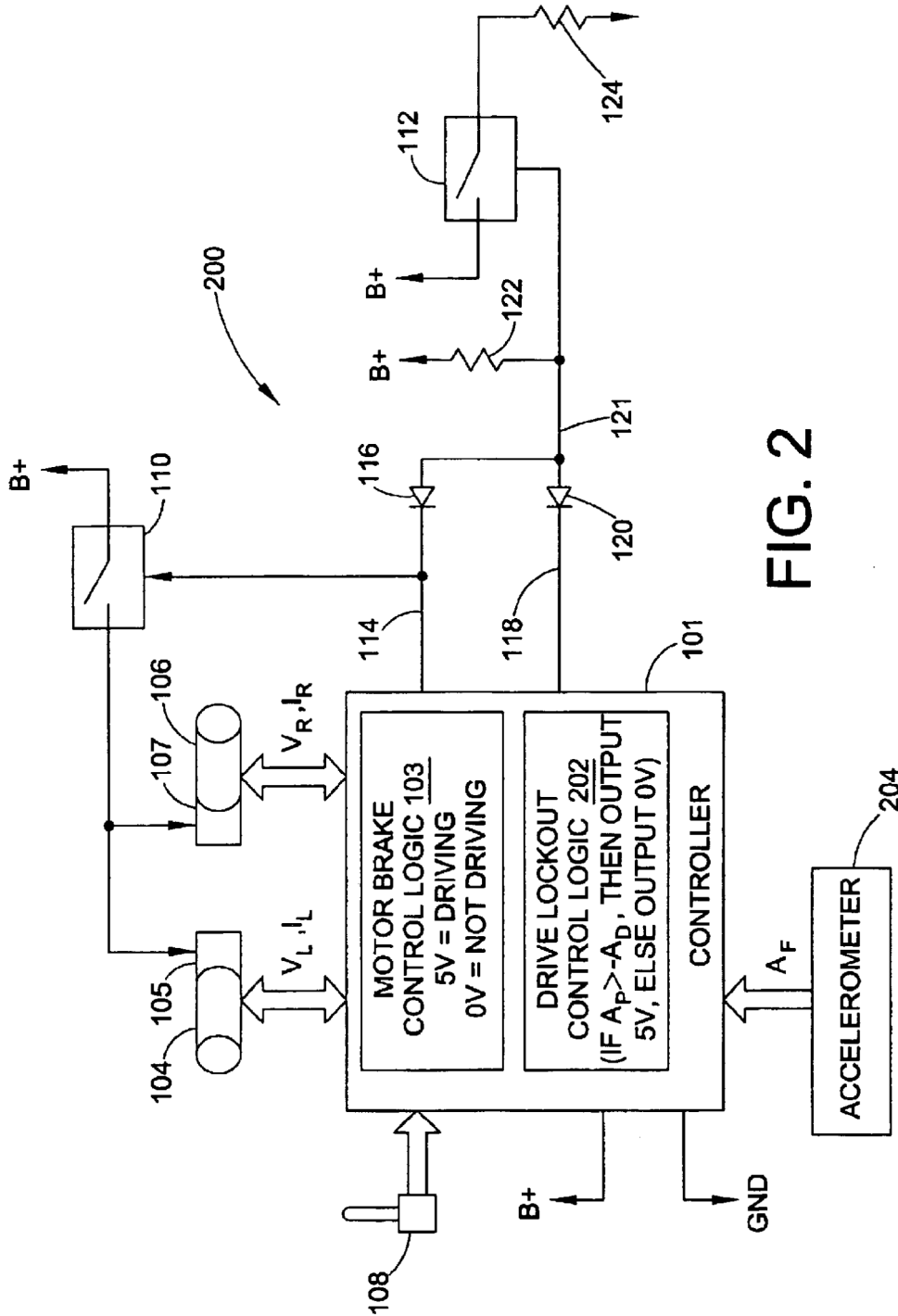

FIG. 2

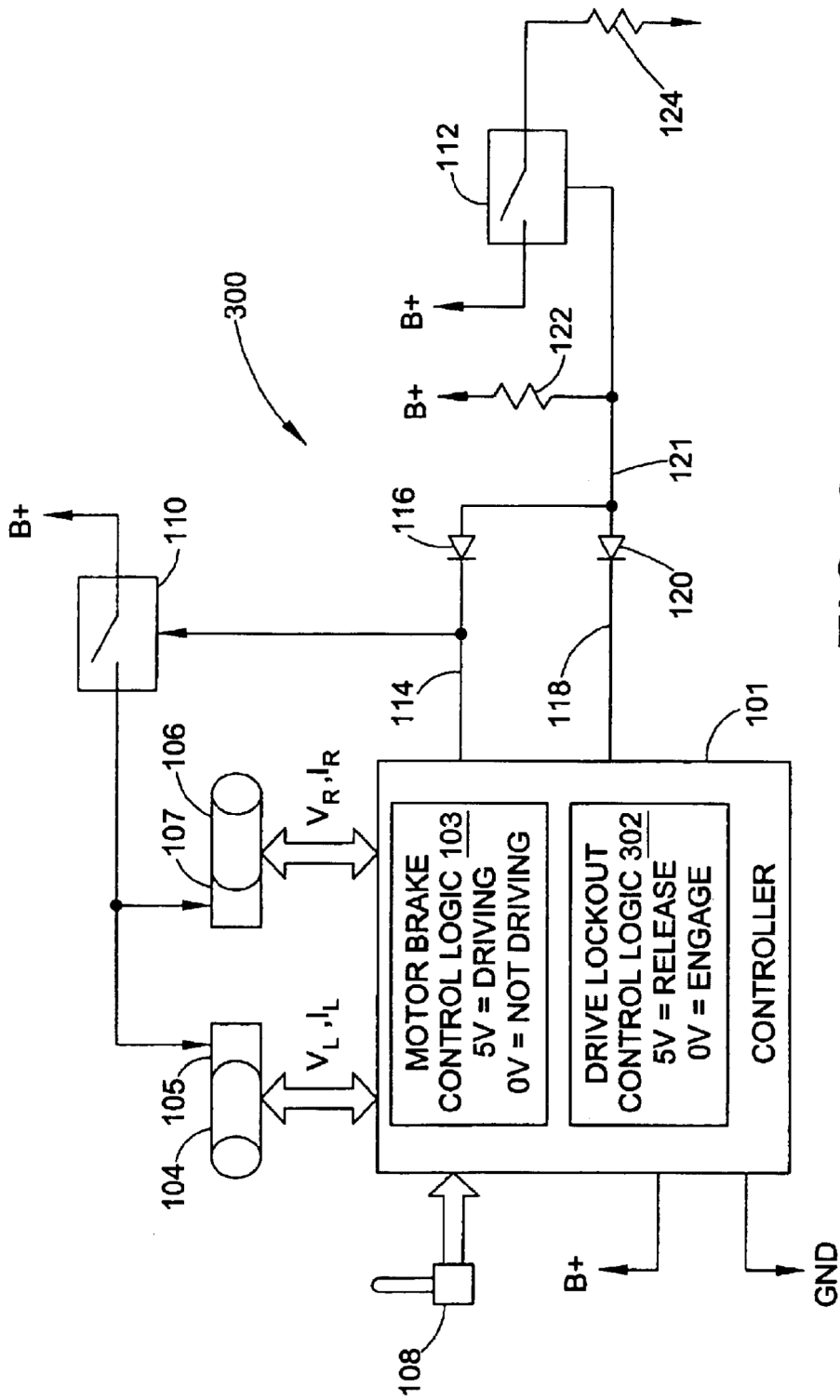

FIG. 3

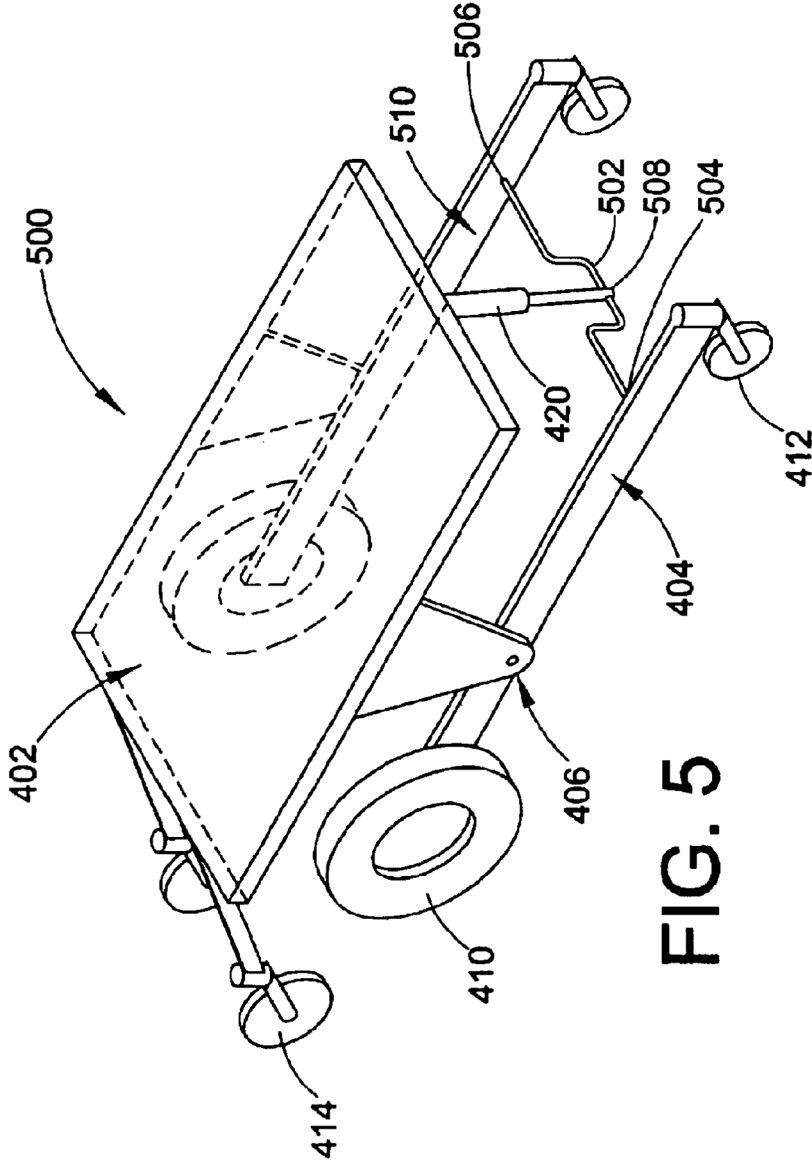

FIG. 5

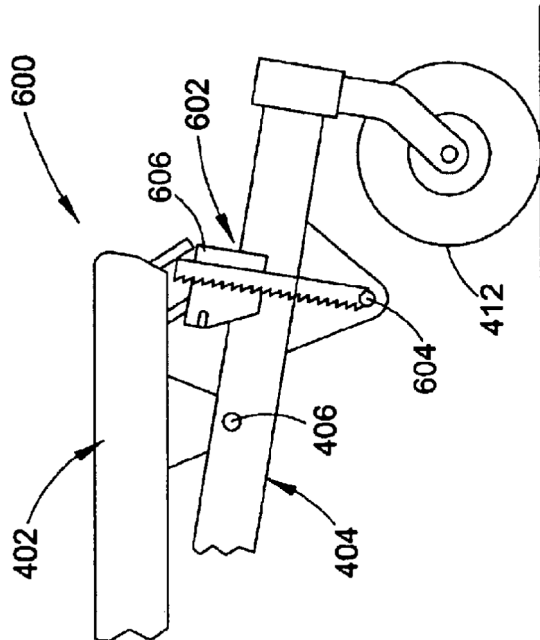

FIG. 6A

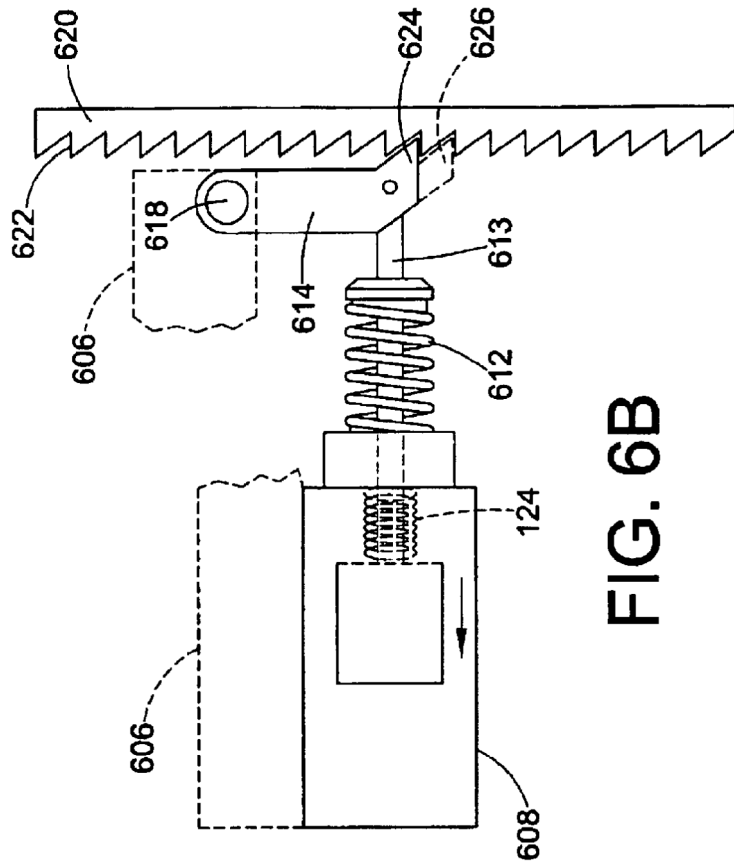

FIG. 6B

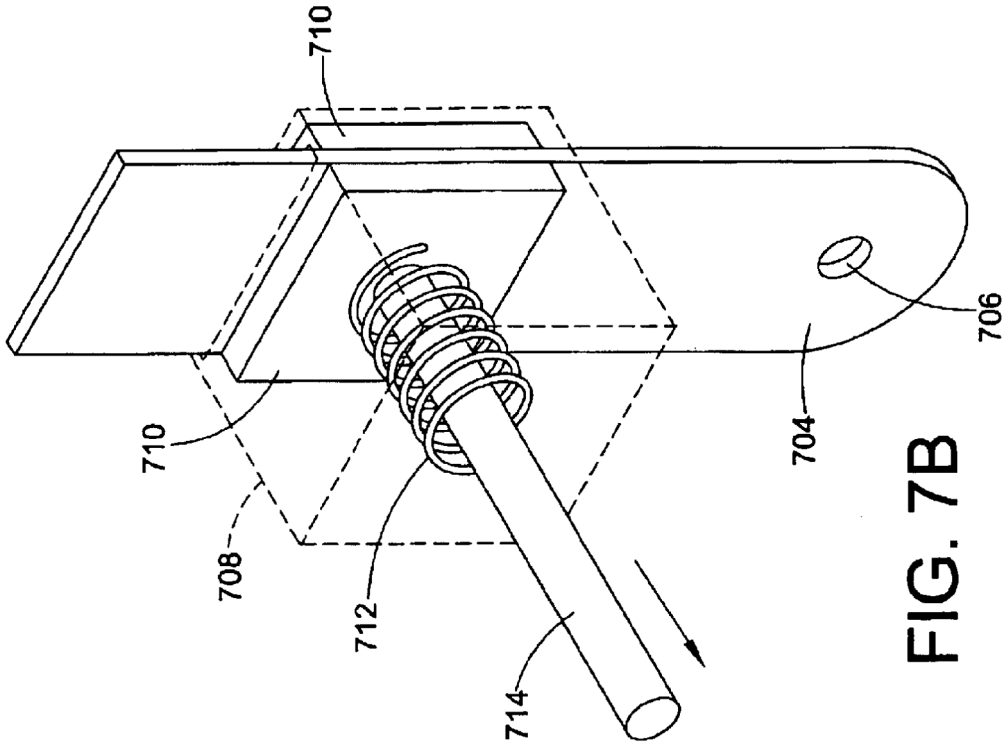

FIG. 7B

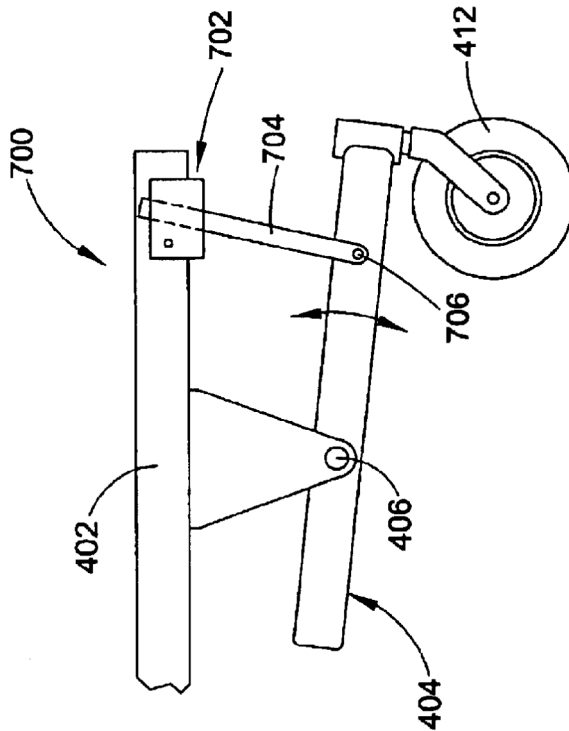
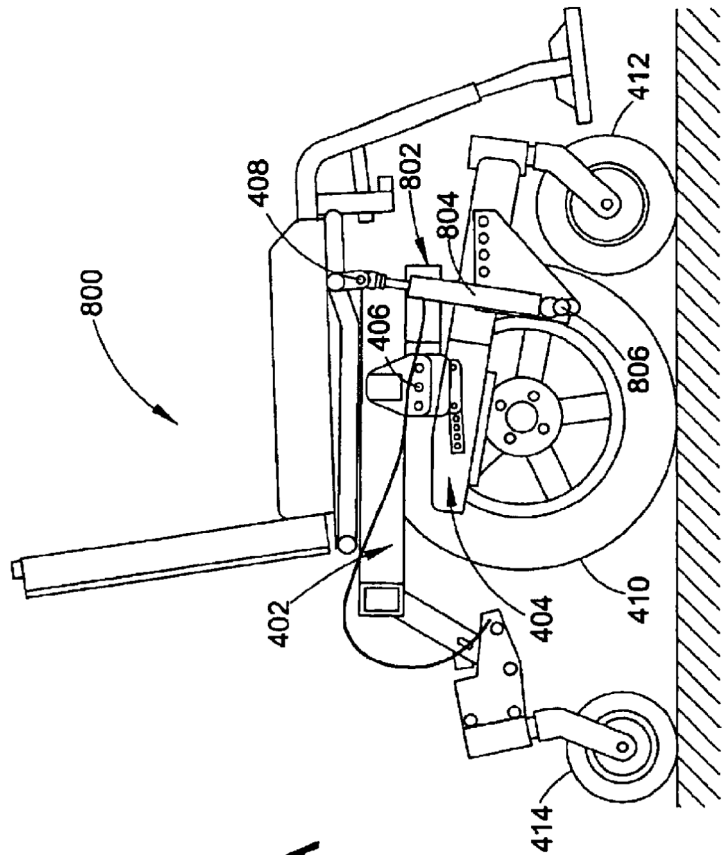
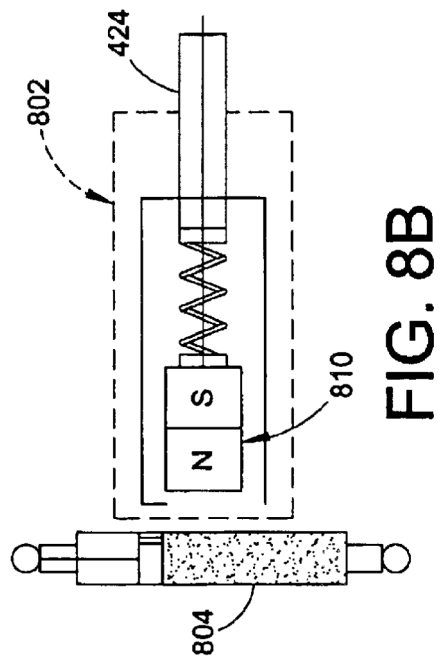
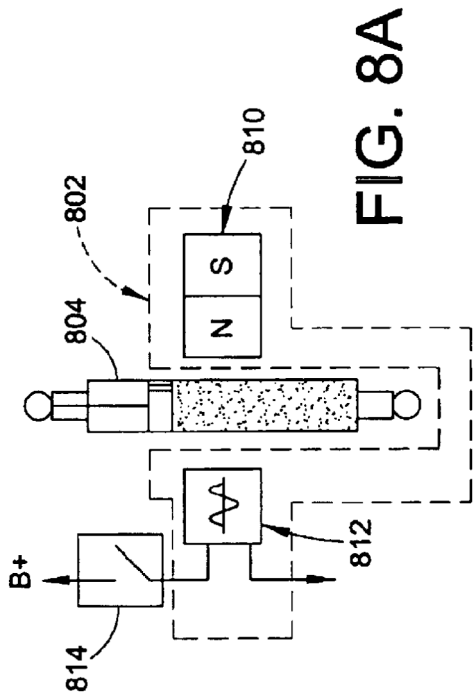

FIG. 7A



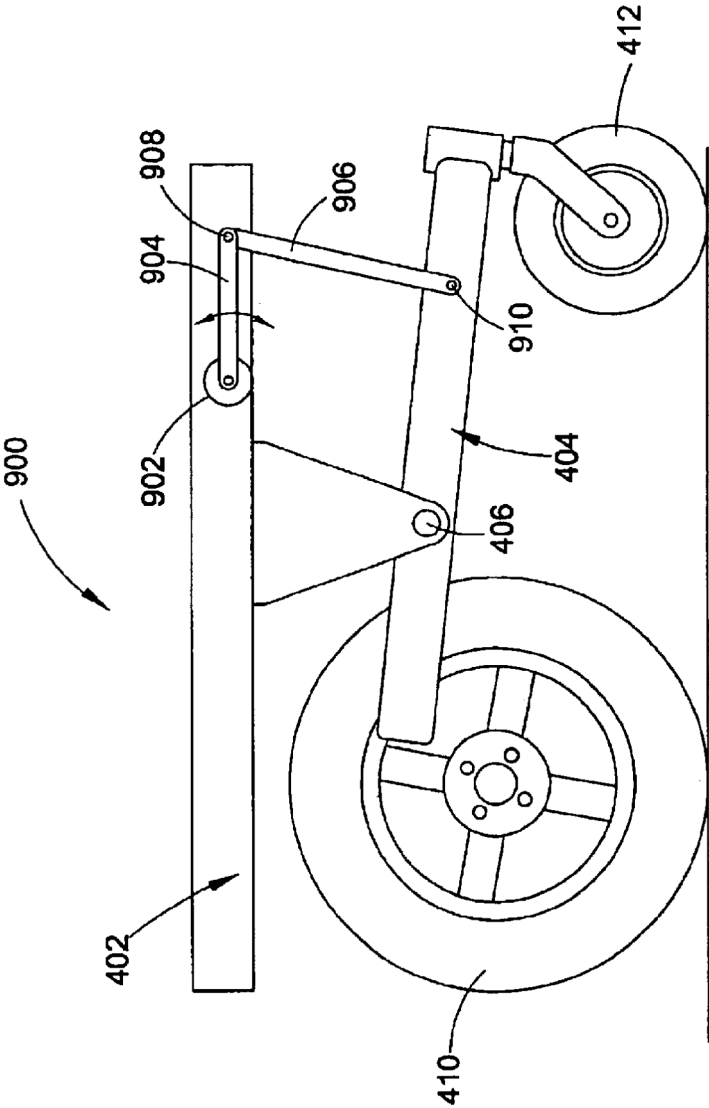

FIG. 9

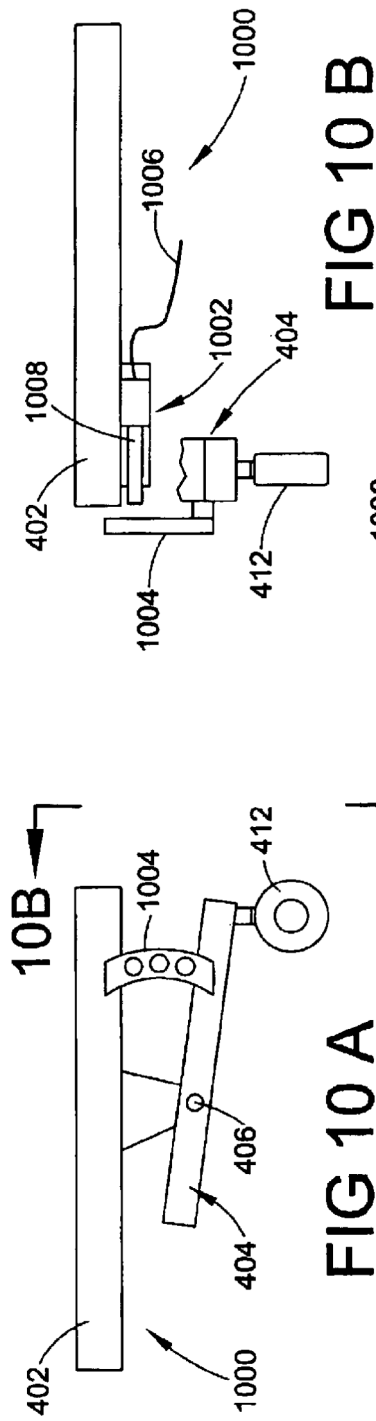

FIG 10 B

FIG 10 A

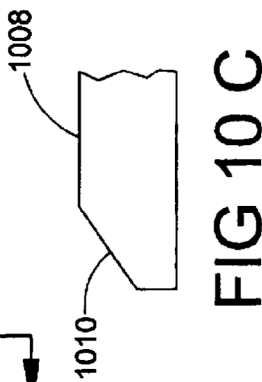

FIG 10 C

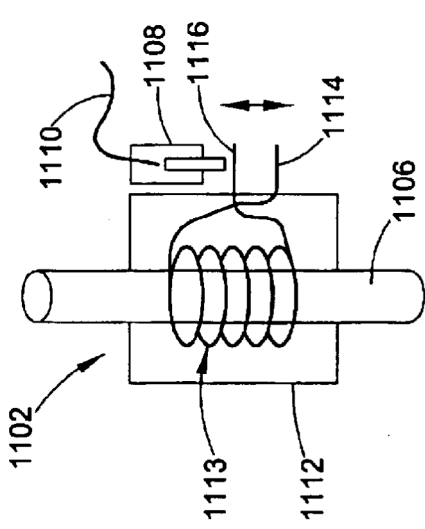

FIG 11 B

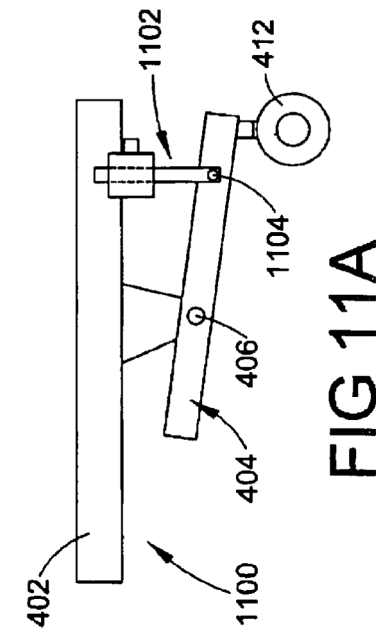

FIG 11 A

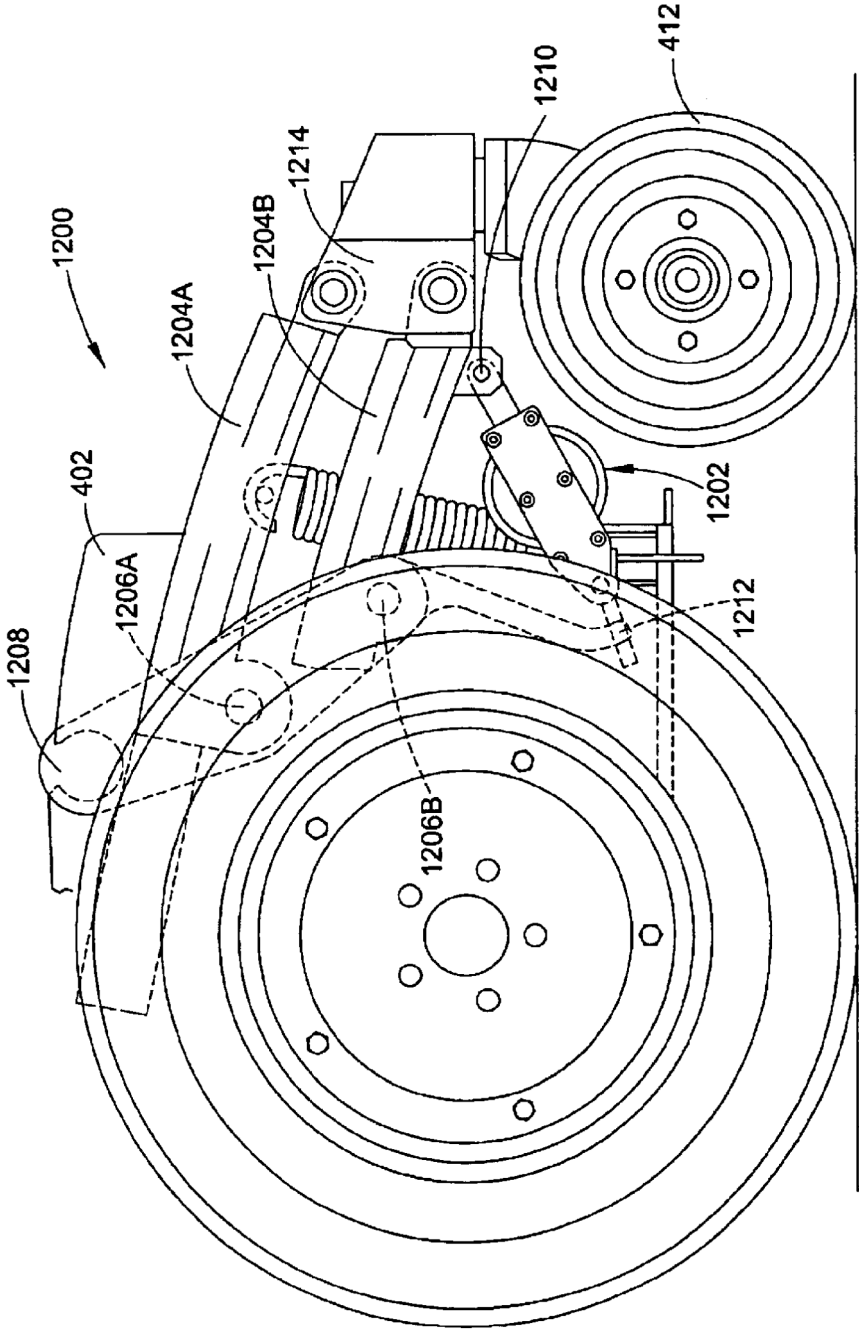

FIG. 12A

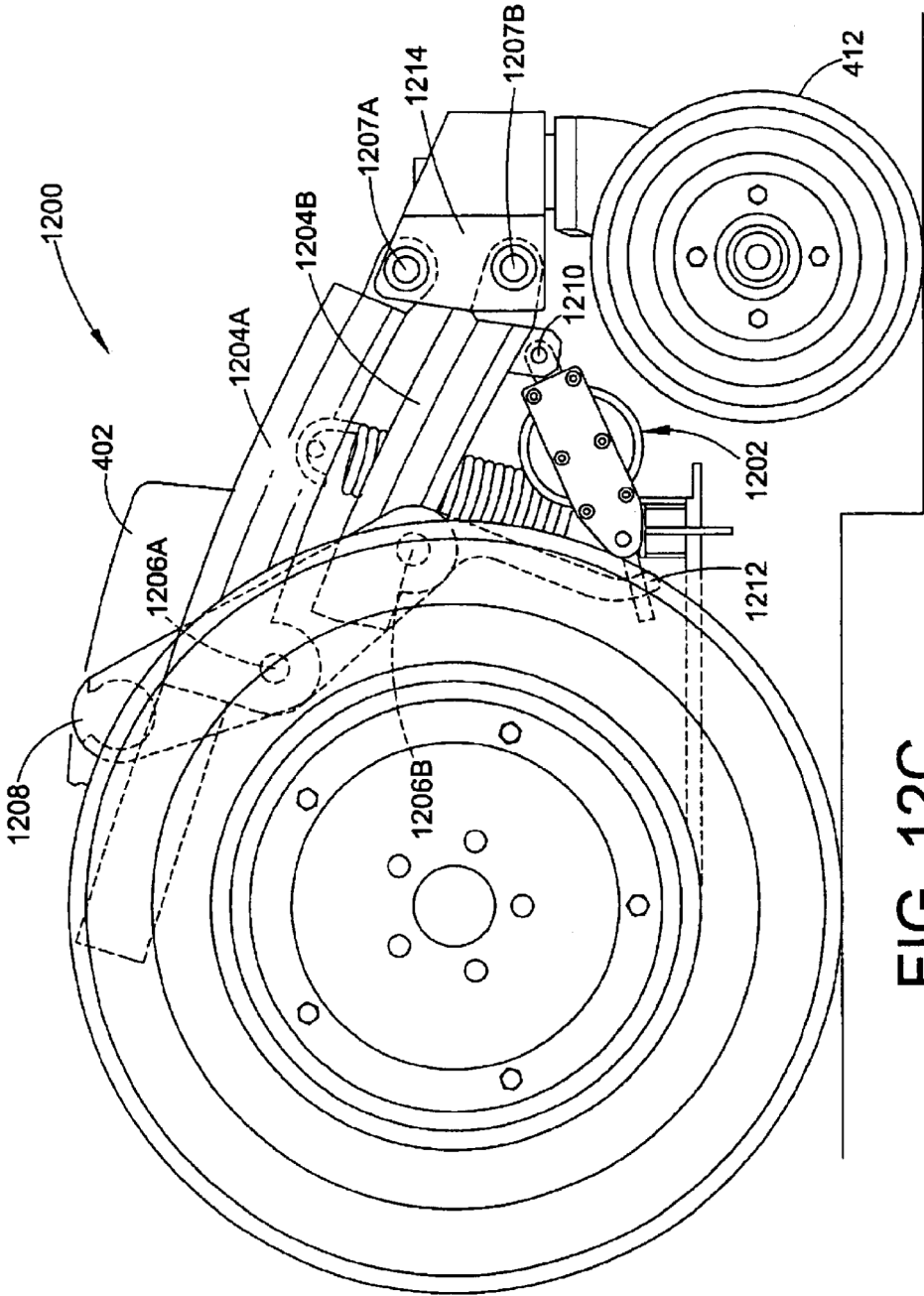

FIG. 12C

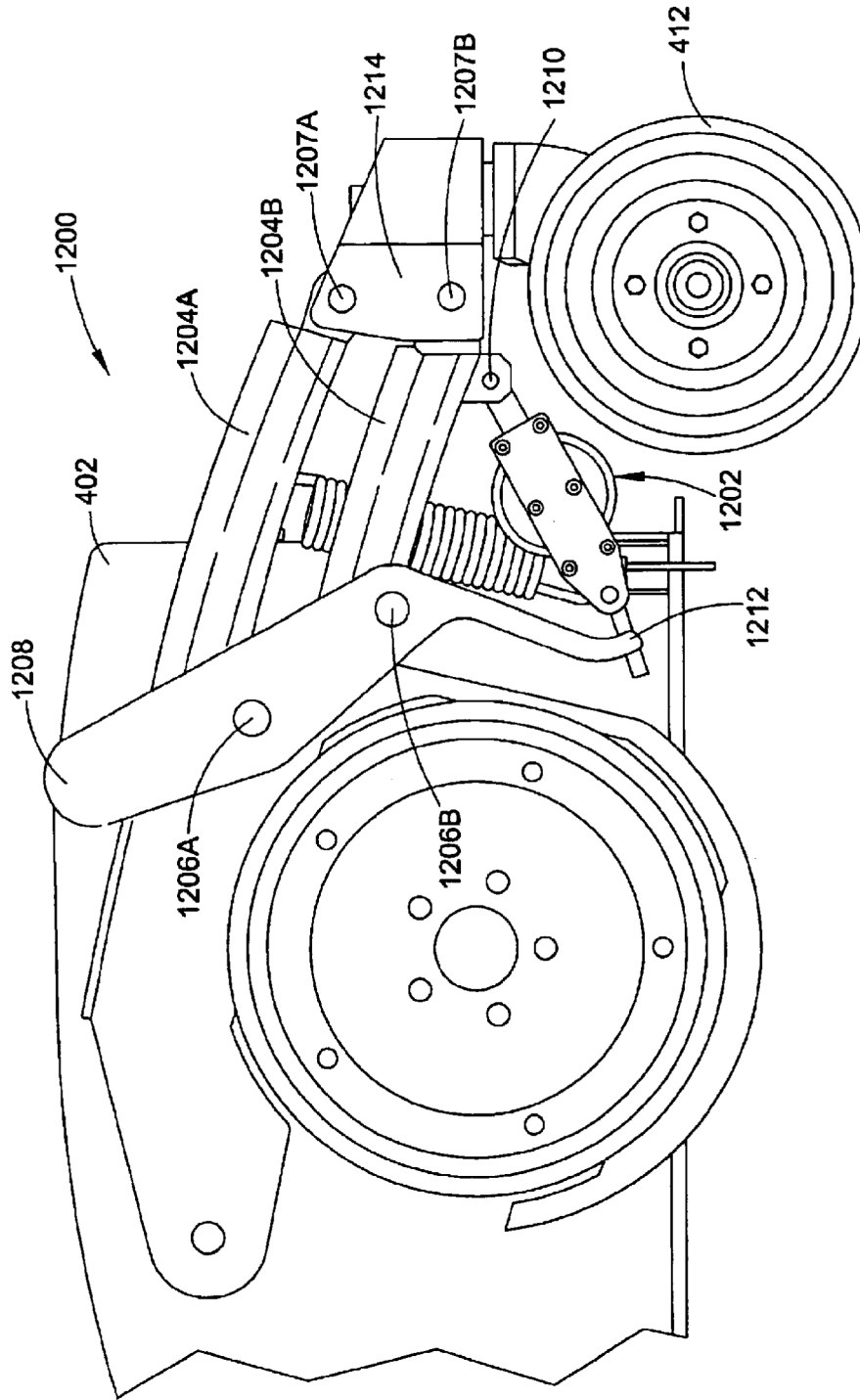

FIG. 12D

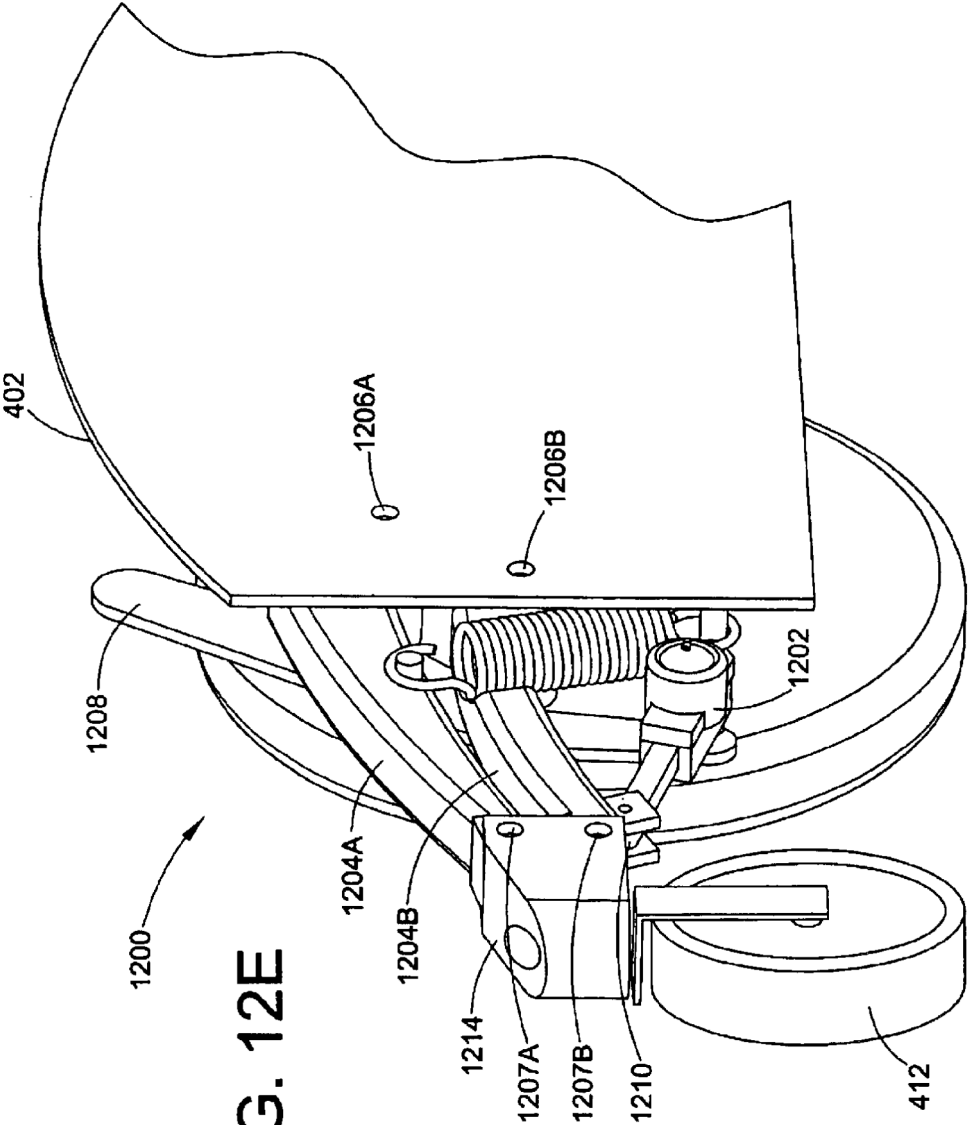

FIG. 12E

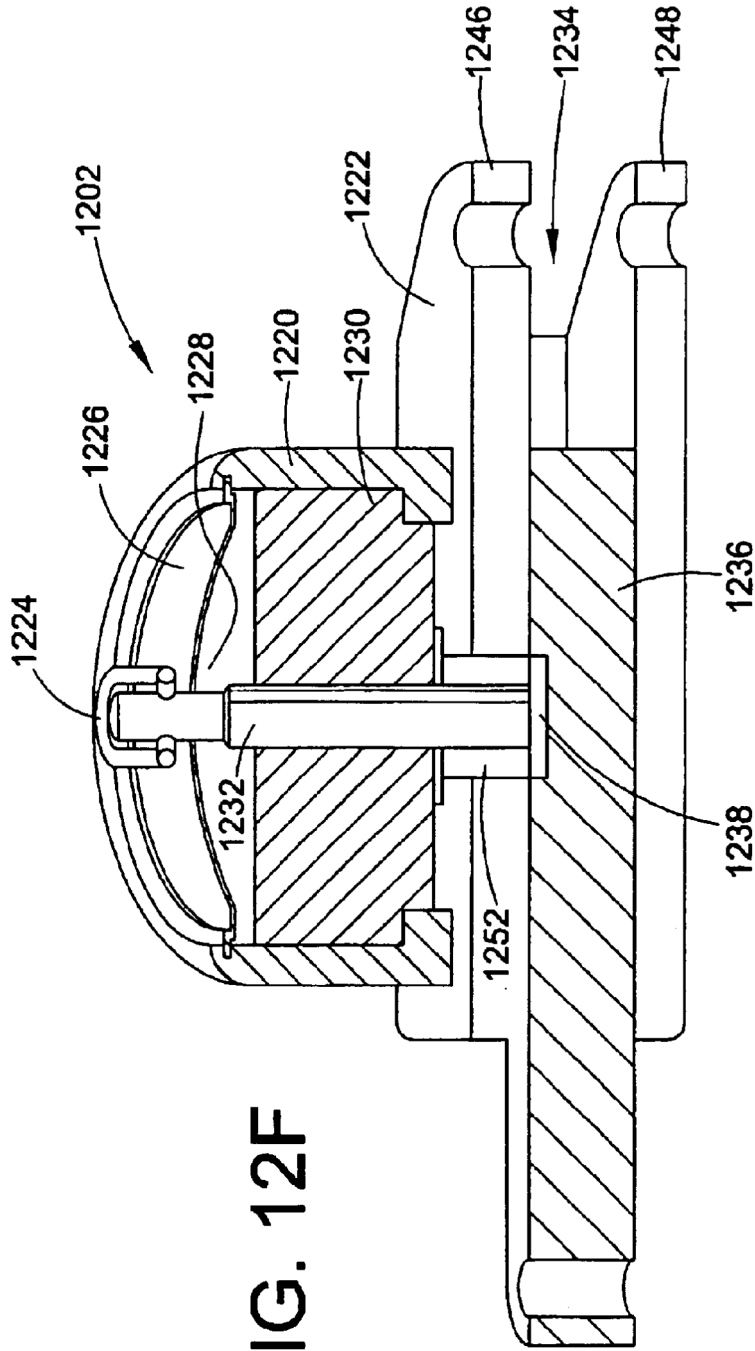

FIG. 12F

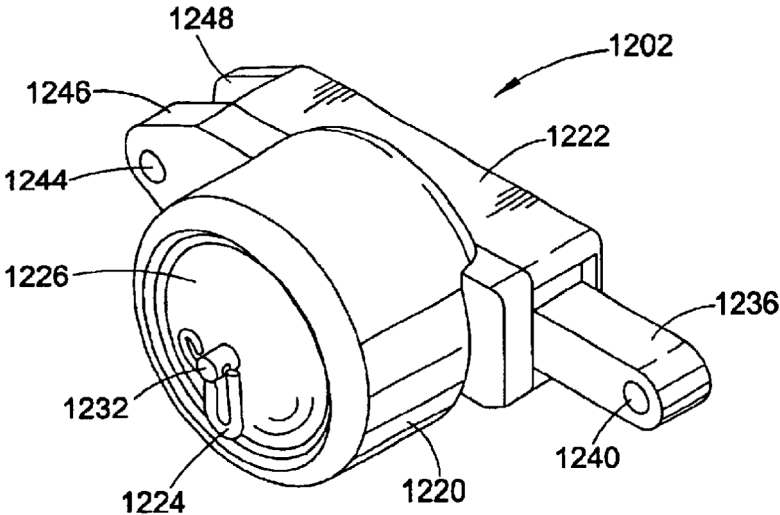

FIG. 12G

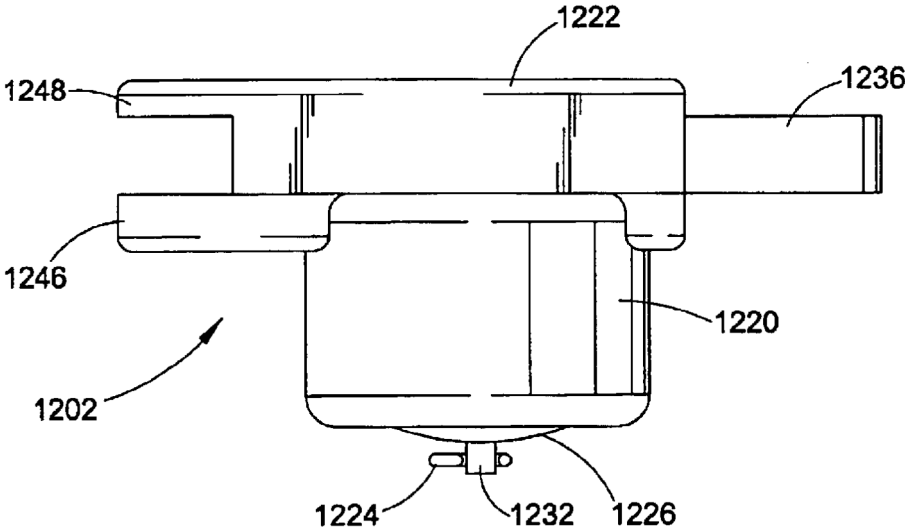
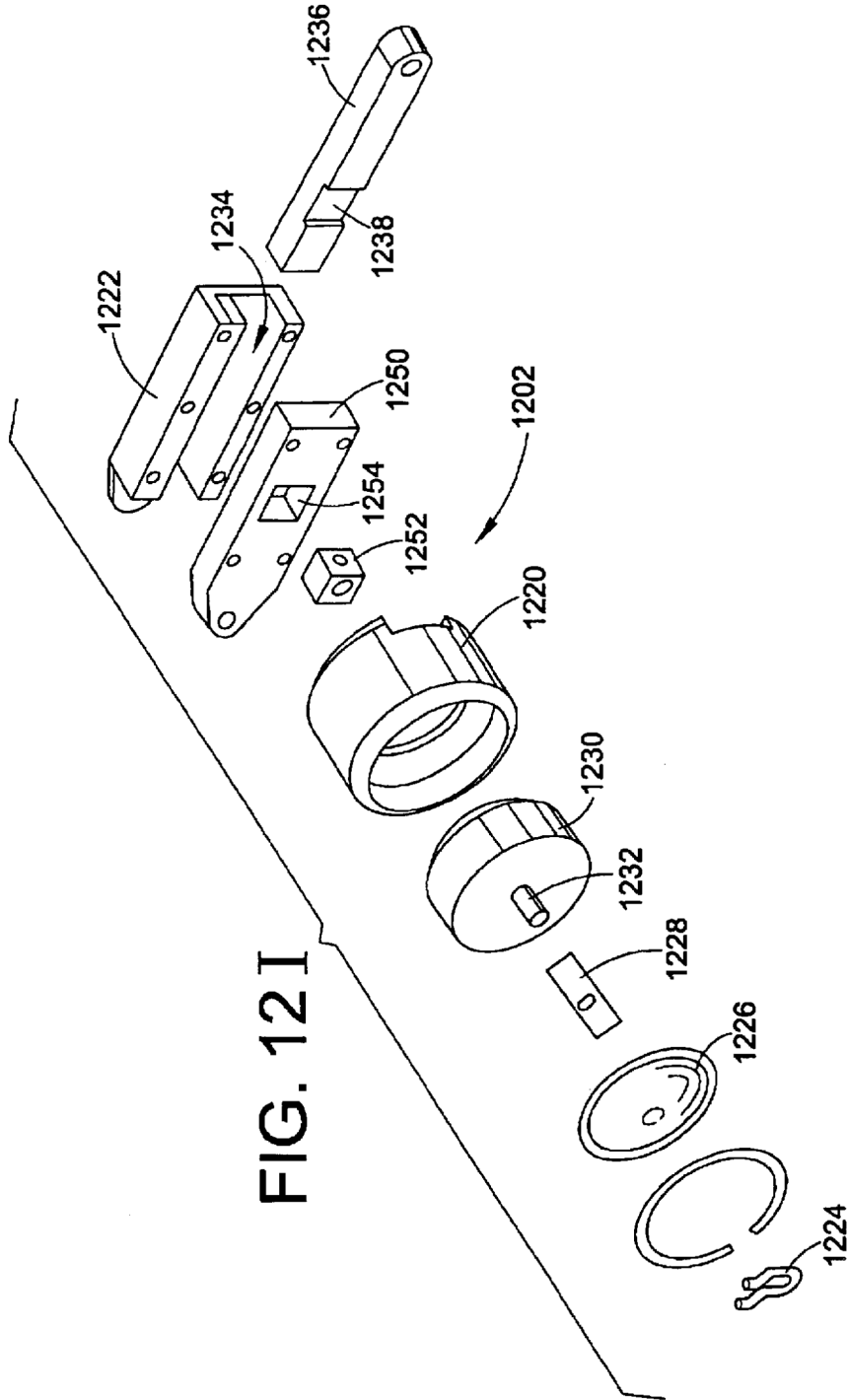

FIG. 12H



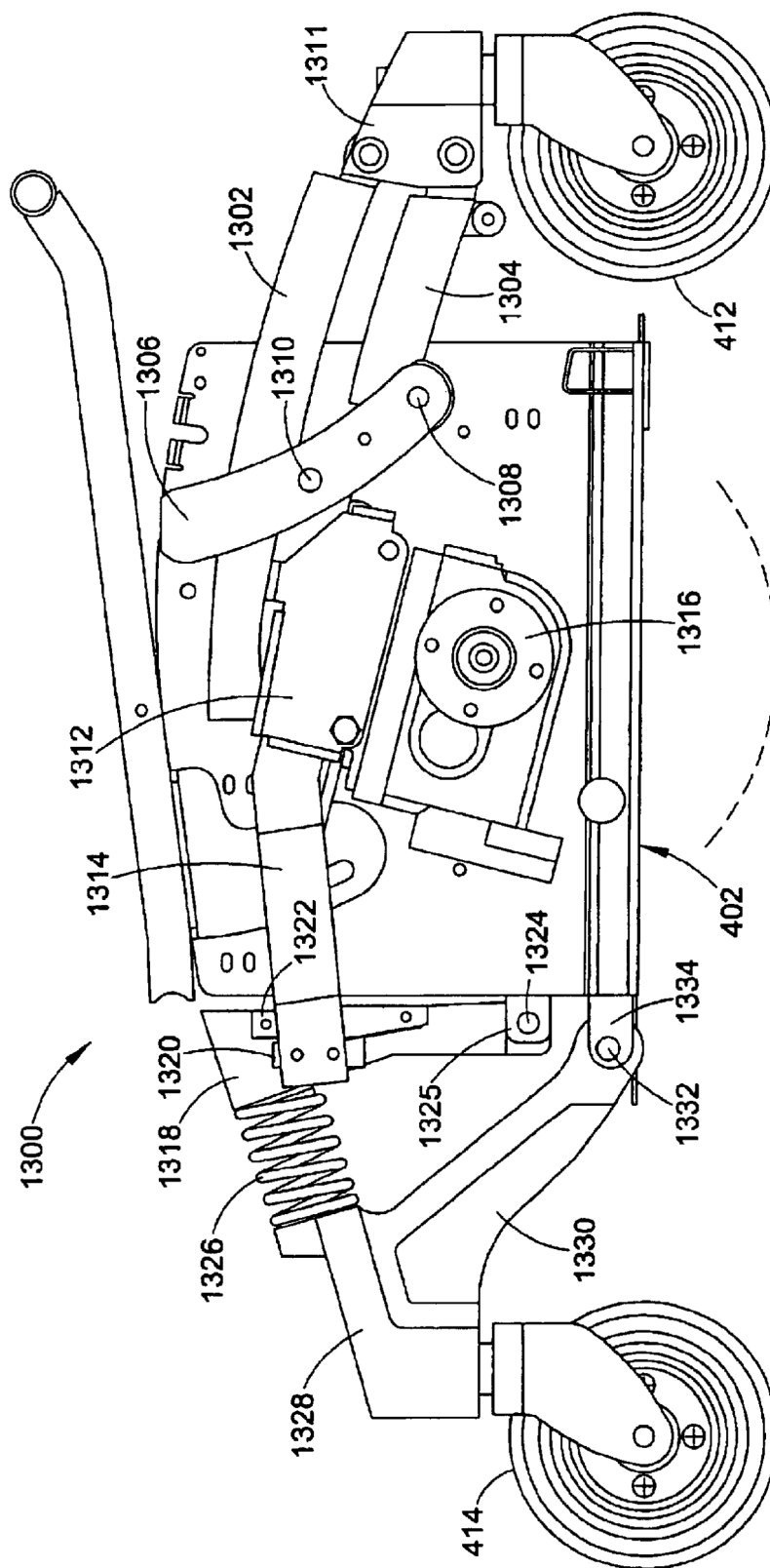

FIG. 13

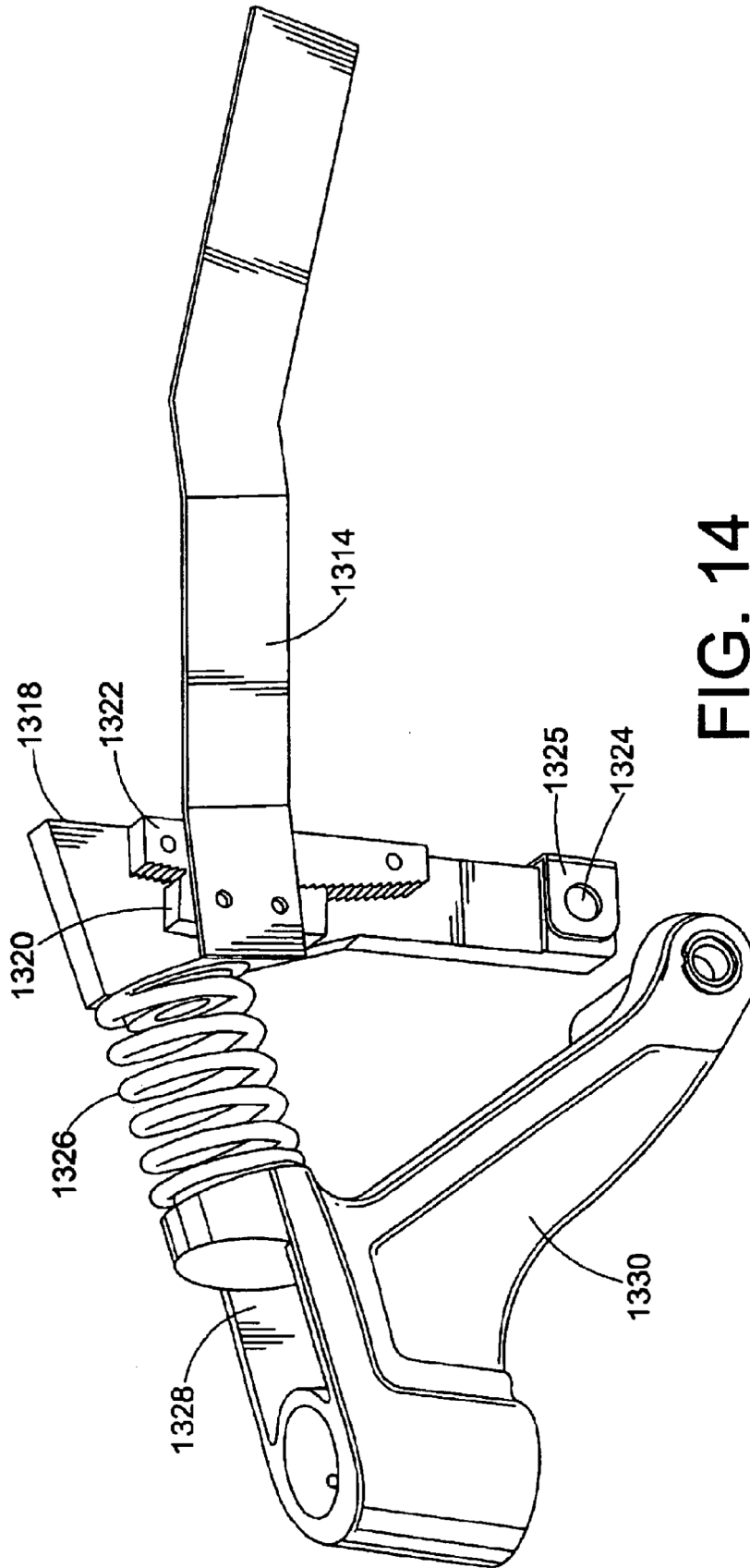
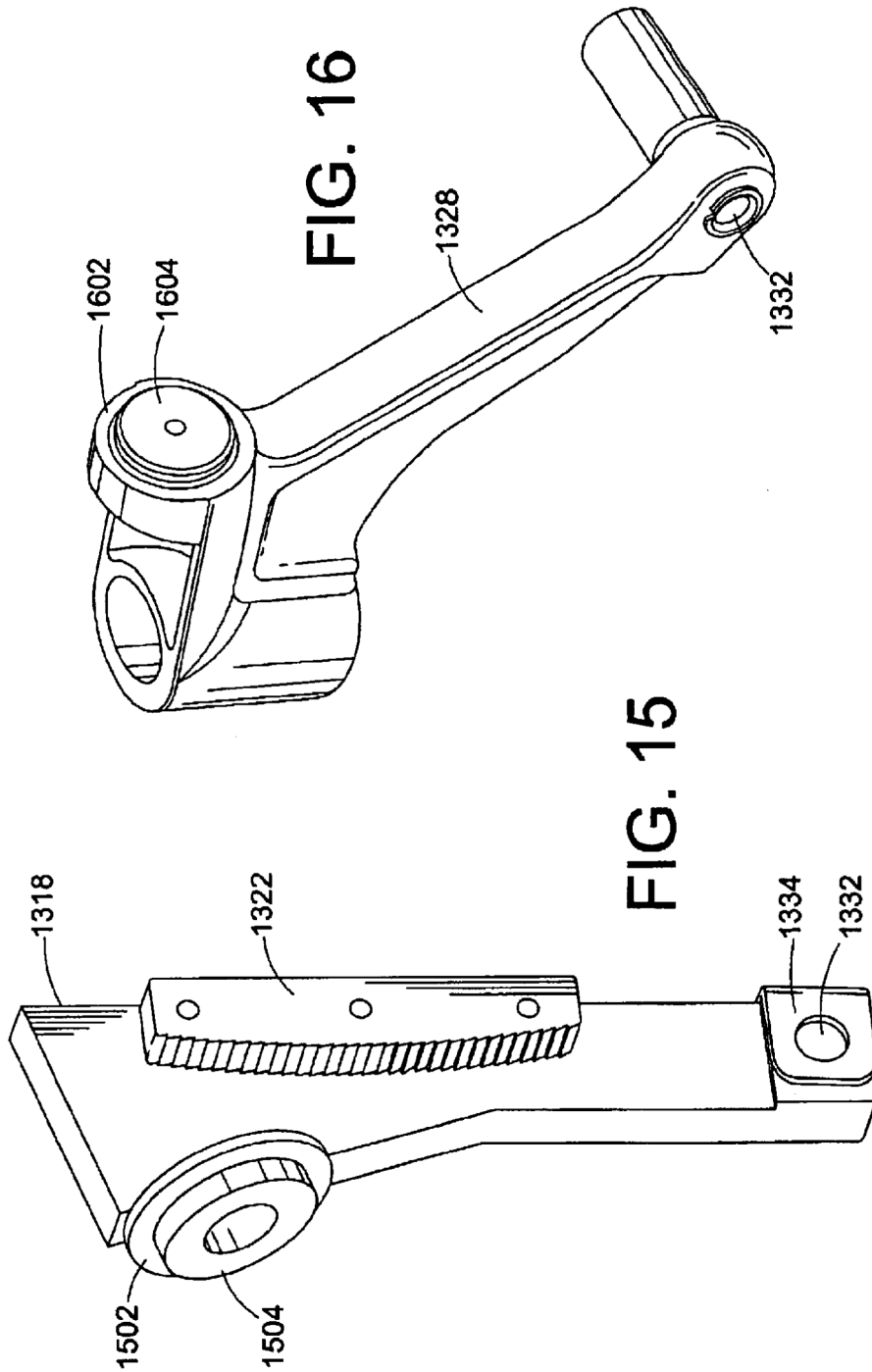

FIG. 14



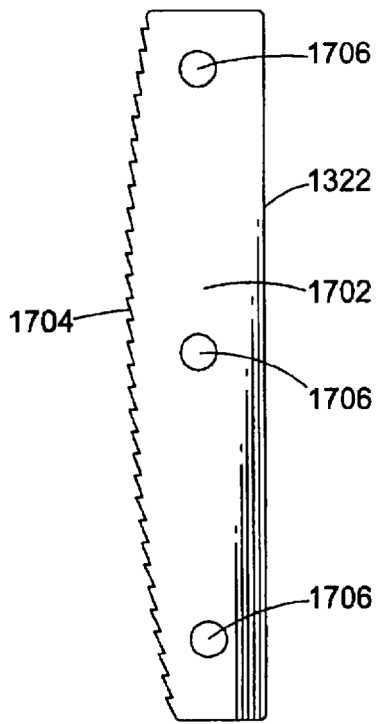

FIG. 17A

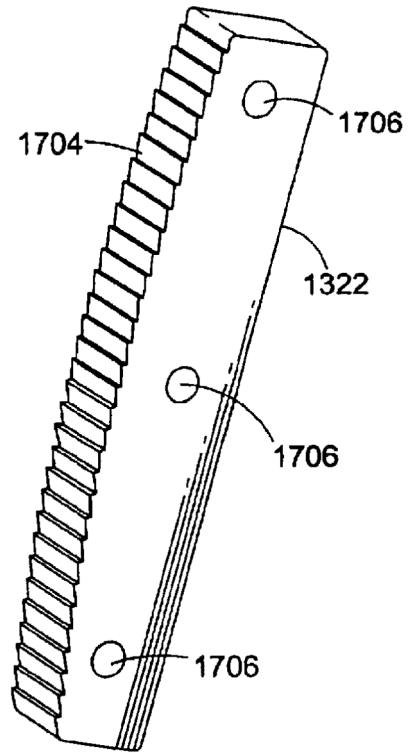

FIG. 17B

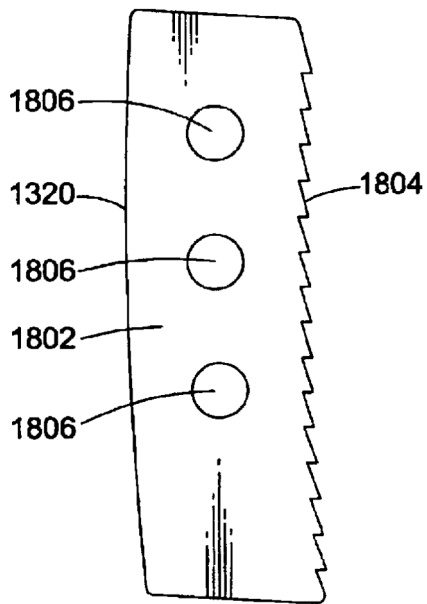

FIG. 18A

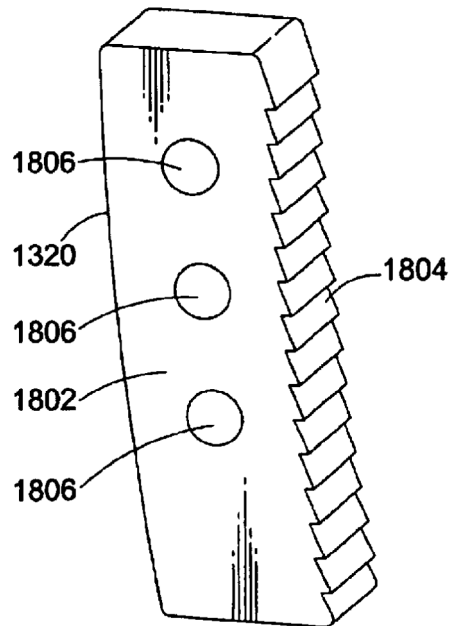

FIG. 18B

1

VEHICLE HAVING AN ANTI-DIVE/LOCKOUT MECHANISM

CROSS-REFERENCES TO RELATED APPLICATIONS

This application claims priority from Provisional U.S. Patent Application Ser. No. 60/404,180 filed Aug. 16, 2002 and Provisional U.S. Patent Application Ser. No. 60/421,178, filed Oct. 25 2002, both of which are hereby fully incorporated by reference.

FIELD OF THE INVENTION

The invention relates generally to conveyances and, more particularly, to motorized conveyances such as wheelchairs and scooters and the like having mid-wheel drives with forward and rearward stability systems.

BACKGROUND OF THE INVENTION

Wheelchairs and scooters are an important means of transportation for a significant portion of society. Whether manual or powered, these vehicles provide an important degree of independence for those they assist. However, this degree of independence can be limited if the wheelchair is required to traverse obstacles such as, for example, curbs that are commonly present at sidewalks, driveways, and other paved surface interfaces. This degree of independence can also be limited if the vehicle is required to ascend inclines or descend declines.

In this regard, most wheelchairs have front and rear casters to stabilize the chair from tipping forward or backward and to ensure that the drive wheels are always in contact with the ground. One such wheelchair is disclosed in U.S. Pat. No. 5,435,404 to Garin. On such wheelchairs, the caster wheels are typically much smaller than the driving wheels and located both forward and rearward of the drive wheels. Though this configuration provides the wheelchair with greater stability, it can hamper the wheelchair's ability to climb over obstacles such as, for example, curbs or the like, because the front casters could not be driven over the obstacle due to their small size and constant contact with the ground.

U.S. Pat. No. 6,196,343 to Strautnieks also describes a wheelchair having front and rear casters. The front casters are each connected to a pivot arm that is pivotally attached to the sides of the wheelchair frame. Springs bias each pivot arm to limit the vertical movement thereof. So constructed, each front caster can undergo vertical movement when running over an obstacle.

While the above-mentioned art provides various ways of addressing the need for stabilizing mid-wheel drive vehicles, a need for further stabilization exists. For example, though equipped with front and rear suspended casters, most mid-wheel drive wheelchairs exhibit various degrees of tipping forward or rearward when descending declines or ascending inclines. This is because the suspensions suspending the front or rear stabilizing casters are compromised so that they are not made too rigid, which would prevent tipping and also not provide much suspension or are made too flexible thereby effectively not providing any degree of suspension or stabilization. Hence, a need exists for addressing the tipping or "diving" experienced by most mid-wheel drive vehicles that have suspension systems included with their stabilization mechanisms.

SUMMARY OF THE INVENTION

According to one embodiment, a suspension for a vehicle is provided. The suspension includes, for example, a frame

2

and a releasable locking assembly. The releasable locking assembly has, for example, a first assembly movably coupled to the frame, a second assembly movably coupled to the frame, and wherein movement of the frame relative to the first and second assemblies causes the first and second assemblies to engage each other to limit further movement of the frame in at least a first direction.

BRIEF DESCRIPTION OF THE DRAWINGS

In the accompanying drawings which are incorporated in and constitute a part of the specification, embodiments of the invention are illustrated, which together with a general description of the invention given above and the detailed description given below, serve to example the principles of this invention.

FIG. 1 is a block diagram of a first embodiment of an electronic-based stabilization system.

FIG. 2 is a block diagram of a second embodiment of an electronic-based stabilization system.

FIG. 3 is a block diagram of a third embodiment of an electronic-based stabilization system.

FIG. 4 is a side elevation overview of a first embodiment of a mechanically-based stabilization system.

FIG. 5 is a partial perspective view of a second embodiment of a mechanically-based stabilization system.

FIGS. 6A and 6B illustrate a first embodiment of a locking member or assembly.

FIGS. 7A and 7B illustrate a second embodiment of a locking member or assembly.

FIGS. 8A, 8B, and 8C illustrate a third embodiment of a locking member or assembly.

FIG. 9 illustrates a fourth embodiment of a locking member or assembly.

FIGS. 10A, 10B, and 10C illustrate a fifth embodiment of a locking member or assembly.

FIGS. 11A and 11B illustrate a sixth embodiment of a locking member or assembly.

FIGS. 12A through 12I illustrate a seventh embodiment of a locking member or assembly.

FIGS. 13-18B illustrate an eighth embodiment of a locking member or assembly.

DETAILED DESCRIPTION OF ILLUSTRATED EMBODIMENT

Generally, a mid-wheel drive wheelchair or scooter is a vehicle used to assist those having an impaired ability to transport themselves. As such, the mid-wheel drive wheelchairs and scooters of the present invention have at least two drive wheels that are positioned approximately below the center of gravity of the vehicle when loaded with a user. This results in approximately 85% or more of the total wheelchair or scooter weight being on the two drive wheels. Mid-wheel drive wheelchairs and scooters also include one or more casters for forward and rearward stability, respectively positioned forward and rearward of the drive wheels. One example of a mid-wheel drive wheelchair can be found in U.S. Pat. No. 5,435,404 to Garin, which is hereby fully incorporated by reference.

At least one motor or combination motor/gear box is provided to drive the drive wheels. The motor is typically controlled by an electronic controller connected to one or more user control devices. The user control devices generally provide selection of forward and reverse movement of the vehicle, as well as controlling the velocity or speed. A

3

battery typically supplies the controller and drive motors with an energy supply. Dynamic braking and an automatic park brake are also incorporated into the vehicle. The dynamic brake allows the operator to proceed safely, even down a slope, without worrying that the vehicle will unreasonably increase in speed while going down the slope. Further, the park brake automatically engages to hold the vehicle in place when the vehicle is standing still.

The present invention provides multiple embodiments of a stabilization system that provides mid-wheel drive vehicles with an anti-dive or lock out mechanism. Generally, the stabilization system includes a trigger or sensor for sensing when conditions exist that may cause the mid-wheel drive vehicle to exhibit a tipping behavior, which can be either forward or rearward, and a locking member or assembly that locks the suspension system to prevent any further tipping behavior. The trigger or sensor also senses when the mid-wheel drive vehicle is no longer subject to conditions that may cause it to exhibit a tipping behavior and causes the locking member or assembly to no longer lock the suspension system.

Referring now to FIGS. 1 and 4, a block diagram of a first embodiment 100 of an electronic-based stabilization system is shown and a representative mid-wheel drive wheelchair is shown, respectively. Referring more specifically to FIG. 4, the mid-wheel drive wheelchair has a frame 402 and pivot arm 404. A pivotal connection 406 connects frame 402 and pivot arm 404. Attached to pivot arm 404 is a drive wheel 410. This attachment is typically provided through a motor or motor/gear box that is attached to pivot arm 404. Pivot arm 404 further has a front caster 412 attached to a forward portion thereof, while the motor or motor/gear box is attached to a more distal opposite portion. Mounting brackets and/or apertures are provided in pivot arm 404 for connecting pivot arm 404 to frame 402 via pivotal connection 406. A rear caster assembly 416 is provided that includes a frame member 418 and caster 414. A second pivot arm and assembly is similarly provided on the opposite of the wheelchair, as shown in FIG. 5.

Referring now to FIG. 1, the stabilization system triggers a locking member or assembly whenever the summation of moments or torque about pivotal connection 406 exceeds a pre-loaded value or, in other words, causes the frame 402 of the wheelchair to tip forward. One of the moment arms that influences this loading is the moment arm defined by the distance from the center of gravity Cg of the mass of the wheelchair occupant and seat 408 to pivotal connection 406. The torque or moment acting on the center of gravity Cg is generally defined by: (mass of the wheelchair occupant and seat) × [(wheelchair acceleration) + (sine of the slope angle) × (acceleration of gravity)]. The slope angle is the slope of the angle measured from a horizontal. For example, if the wheelchair is traveling on a horizontal surface, the slope angle is zero (0) degrees. If the wheelchair is traveling up an incline, the slope angle may be, for example, five (5) degrees. If the wheelchair is traveling down a decline, the slope angle may be, for example, minus five (-5) degrees. As such, the present invention is configured to trigger the locking member or assembly sooner when traveling down declines (i.e., negative slope angle), compared to when traveling up inclines (i.e., positive slope angle).

As illustrated in FIG. 1, the system 100 includes a controller 101, dive lockout control logic 102, and motor/brake logic 103. Controller 101 is any computer-based controller suitable for controlling a vehicle. In this regard, controller 102 generally has a processor, memory, and input/output components (not shown). Controller 101 can

4

also have electric motor drive circuitry associated therewith (not shown) that connects to drive motors 104 and 106. A user input device 108 such as, for example, a joystick, provides control information to the controller 101 for driving the wheelchair. A sensor 126 is provided for sensing the force acting on the center of gravity Cg of the wheelchair occupant and seat and outputs a signal S to controller 102. As will be presently described, sensor 126 can be any one of several embodiments. The remainder of system 100 includes electronic switches 110 and 112, nodes 114, 118, and 121, diodes 116 and 120, resistor 122 and solenoid coil 124. Solenoid coil 124 is part of an electronic locking member or assembly such that the state of the coil (i.e., energized or unenergized) defines the state of the locking member or assembly (i.e., locking or not locking the suspension system).

In operation, controller 101 receives driving command inputs from joystick 108. This causes controller 101 to output voltages V_L and V_R and current I_L and I_R to the left and right motors 104 and 106, respectively. Attached to each motor is a motor lock 105 and 107, respectively. All the components of the system are typically powered by battery having a positive voltage potential B+ and a ground potential "Gnd." The sensor 126 is mounted on the wheelchair so as to generate a trigger signal S when the wheelchair is tipping forward. In the presently described embodiment, the trigger signal S is an electronic signal. In other embodiments, this can be a mechanical signal such as that generated by a push-pull cable assembly.

Solenoid coil 124 is controlled by the state of electronic switch 112. The locking member or assembly associated with solenoid coil 124 is preferably in its unlocked state when solenoid coil 124 is energized and in its locked state when solenoid coil 124 is unenergized. Alternatively, the opposite configuration can also be employed.

Nodes 114 and 118 and diodes 116 and 120 form an OR circuit that controls the state of electronic switch 112 and, hence, the energy state of solenoid coil 124. More specifically, node 114 forms one input to the OR circuit and relates to the state of the motor brakes. For example, when the motors are being driven, the brakes disengage and motor/brake logic 103 causes node 114 to be at 5V. This, in turn, causes electronic switch 112 to close thereby energizing solenoid coil 124 and releasing the locking member or assembly from locking the wheelchair suspension. When the motors are not being driven, the brakes are engaged and motor/brake logic 103 causes node 114 to be at 0V. This causes electronic switch 112 to open, which de-energizes solenoid coil 124 thereby engaging the locking member or assembly to lock the suspension.

Node 118 forms the second input to the OR circuit and relates to input provided by sensor 126 for detecting when conditions may exist that indicate the wheelchair may start exhibiting a tipping behavior. More specifically, if sensor 126 is not indicating that conditions exist under which wheelchair may exhibit a tipping behavior, dive lockout control logic 102 interprets this state and causes node 118 to be at 5V. This, in turn, causes electronic switch 112 to close thereby energizing solenoid coil 124 and releasing the locking member or assembly from locking the wheelchair suspension. When sensor 126 senses that conditions exist for a tipping behavior, dive lockout control logic 102 interprets this state and causes node 118 to be at 0V. This, in turn, causes electronic switch 112 to open thereby de-energizing relay 124 and engaging the locking member or assembly to lock the wheelchair suspension.

Illustrated in FIG. 2 is an embodiment 200 of a stabilization system similar to embodiment 100 of FIG. 1. In

5

embodiment **200**, the sensor **126** (of embodiment **100**) includes an accelerometer **204** that produces an acceleration input signal A_F to controller **101**. Accelerometer **204** can be any convention accelerometer that provides an output signal that is proportional to the sensed acceleration. In one embodiment, accelerometer **204** can be an appropriately damped pendulum mercury switch. In another embodiment, accelerometer **204** can be an electronic accelerometer such model no. ADXL202 manufactured by Analog Devices of Norwood, Mass. Accelerometer **204** is preferably located on or near the wheelchair seat proximate the center of gravity C_g of the wheelchair seat and occupant.

The operation of embodiment **200** is substantially the same as embodiment **100**, except that the state of node **118** is dependent on acceleration signal A_F . The acceleration signal A_F is compared by the dive lockout control logic **202** to a dive threshold acceleration parameter A_D , which may be negative ($-A_D$) indicating wheelchair deceleration. The value of dive threshold acceleration parameter A_D can be either calculated based on the weight of the wheelchair and occupant or determined experimentally with the actual wheelchair and a range of seat occupant weights. As such, dive threshold acceleration parameter $-A_D$ is a parameter that is used by the dive lockout control logic **202** to determine if conditions are present under which the wheelchair may exhibit a tipping behavior. When dive lockout control logic **202** determines that acceleration signal A_F is more negative than dive threshold parameter $-A_D$, it drives node **118** to 0V. This causes electronic switch **112** to open thereby de-energizing solenoid coil **124** and causing the locking member or assembly to lock the wheelchair suspension. Acceleration signal A_F is negative when the wheelchair is decelerating or facing a downward slope or decline. Otherwise, node **118** is maintained at 5V thereby causing electronic switch to close. This, in turn, causes solenoid coil **124** to be energized thus releasing the locking member or assembly from locking the wheelchair suspension.

Referring now to FIG. **3**, an embodiment **300** of an electronically-based stabilization system is shown. Embodiment **300** is substantially similar to embodiment **100**, except that sensor **126** includes a motor voltage and/or current sensor, which can be incorporated into controller **101**. In this regard, controller **101** can incorporate an analog-to-digital (A/D) converter circuit or can include an external A/D circuit. This A/D circuit converts analog signals such as, for example, voltage or current signals, to digital or binary signals for input into or interpretation by controller **101**. Connected therewith, controller **101** also includes dive lockout control logic **302** for interpreting these voltage and/or current signals.

The operation of embodiment **300** is substantially similar to embodiment **200**, except that dive lockout control logic **302** interprets how hard the motor is being driven and dynamically braked to determine whether the locking member or assembly will lock or release the suspension system. In this regard, node **114** behaves as earlier described. Node **118** is driven to 0V when the wheelchair is traveling forward and there is a large amount of dynamic braking being generated by motors **104** and **106**. Node **118** is also driven to 0V if the wheelchair is accelerating hard in the reverse direction of travel. Otherwise, node **118** is driven to 5V. As used herein, dynamic braking generally refers to the process by which a motor's windings are short-circuited when the motor is not being driven so that the residual rotational energy of the motor causes the motor to act as a generator that generates a voltage and current. By re-circulating the current generated of this configuration, the motor dynami-

6

cally brakes itself. The behavior of node **118**, as described above, is further embodied by Equations (1) and (2) below:

$$\text{If } (V_L+V_R)>0 \text{ and } (I_L+I_R)<-I_D, \text{ then output 0V on node } \mathbf{114} \text{ Eq. (1)}$$

$$\text{If } (V_L+V_R)<0 \text{ and } (I_L+I_R)>I_D, \text{ then output 0V on node } \mathbf{114} \text{ Eq. (2)}$$

In the above equations, V_L , V_R , I_L , and I_R are the approximate terminal voltages and currents of motors **104** and **106**, respectively. Variable I_D is a threshold parameter representing a current level that is used to determine when the motors are being dynamically braked. The value of threshold parameter I_D can be calculated based on the motor specification and weight of the wheelchair and occupant or determined experimentally based on the actual wheelchair weight and a range of seat occupant weights. Equation (1) causes node **118** to be driven to 0V when the wheelchair is traveling forward ($(V_L+V_R)>0$) and the motors are dynamically braking themselves ($(I_L+I_R)<-I_D$). Equation (2) also causes node **118** to be driven to 0V when the wheelchair is accelerating hard in the reverse direction ($(V_L+V_R)<0$) and the motors are not dynamically braking themselves ($(I_L+I_R)>I_D$). As described earlier, when node **118** is driven to 0V, electronic switch **112** opens thereby causing solenoid coil **124** to de-energize. De-energizing solenoid coil **124** causes the locking member or assembly to lock the suspension system. Otherwise, node **118** is driven to 5V, which causes electronic switch **112** to close thereby energizing solenoid coil **124**. Energizing solenoid coil **124** causes the locking member or assembly to unlock or release the suspension system. Alternatively, energizing solenoid coil **124** can cause the locking member or assembly to unlock or release the suspension system and de-energizing solenoid coil **124** can cause the locking member to lock the suspension system.

Referring now to FIG. **4**, one embodiment of a mechanically-based stabilization system is shown. In this regard, a locking member **420**, push-pull cable **424**, and pivotal rear castor assembly **416** are provided. Push-pull cable **424** has a first conduit portion attached to a bracket **430** on rear caster frame member **418** and a second portion attached to a locking member control bracket assembly **432**. Push-pull cable **424** also has a first cable portion attached to a rear castor pivot bracket portion **428** and a second cable portion attached to a locking member control arm **422**.

Locking member **420** is pivotally connected to frame **402** and pivot arm **404**. This is accomplished through a conventional pivot assembly that includes pins or bolts extending through mounting brackets. A second similar locking member and push-pull cable are associated with a second pivot arm on the other side of frame **402** and identically configured to locking members **404** and push-pull cable **424**.

In this regard, locking member **420** is preferably a lockable spring device. Examples of such devices include lockable gas or hydraulic springs that include piston valve assemblies for locking the springs in a predetermined position. Such lockable gas or hydraulic springs include, for example, the BLOC-O-LIFT®, STAB-O-MAT®, and STAB-O-BLOC® models of gas springs as manufactured by STABILUS GMBH, Koblenz, Germany. In the preferred embodiment, arm **422** is mechanically linked to the reciprocating rod that opens and closes the piston valve assembly of the locking member **404**.

In operation, when rear castor **414** is contacting the driving surface, push-pull cable **424** causes arm **422** to be pulled toward bracket **432**. This state causes locking member **420** to be in its unlocked state thereby allowing pivot arm **404** to pivot about pivotal connection **406** as front castor **412** traverses bumps and obstacles on the drive surface.

7

However, when the wheelchair begins to exhibit a tipping behavior (e.g., tipping forward), rear caster 414 will pivot about connection 426. Rear caster 414 may or may not completely come off of the driving surface. This causes the cable within push-pull cable 424 to displace. This displacement is translated to arm 422, which begins to separate from control bracket 432. When arm 422 separates from control bracket 432, the locking member enters the locked state thereby locking pivot arm 404 from pivotal motion about connection 406. When the wheelchair returns to its normal position, rear caster 414 pivots back to its normal ground-engaging position thereby releasing locking member 420 via push-pull cable 424. This allows pivot arm 404 to once again pivot about connection 406. Most preferably, the system is configured that if push-pull cable 424 breaks, locking member 420 automatically locks pivot arm 404. Additionally, a resilient spring device can be placed between rear caster pivot bracket portion 428 and rear caster frame member 418 to bias rear caster 414 around connection 426 towards the driving surface.

As an alternative to FIG. 4, push-pull cable 424 can be replaced by a limit switch designed to sense the motion of rear caster pivot bracket portion 428 and a solenoid actuator configured to act upon arm 422 upon movement of the rear caster pivot bracket portion 428 during a wheelchair tipping motion. In this regard, one or more wires connect the limit switch to the solenoid actuator. In yet another alternative, push-pull cable 424 can be replaced with a plurality of mechanical linkages that provide the same effect on arm 422.

Illustrated in FIG. 5 is another alternate embodiment 500 to that FIG. 4. The embodiments of FIGS. 4 and 5 are substantially similar, except that the embodiment of FIG. 5 includes only one locking member 420 that is associated with both pivot arms 404 and 510. To facilitate this configuration, a link 502 is provided between the pivot arms 404 and 510. Link 502 has a first portion 504 that is pivotally connected to first pivot arm 404 and a second portion 506 that is pivotally connected to second pivot arm 510. Link 502 also has a third portion that is pivotally connected to a bottom portion of locking member 420. A top portion of locking member 420 is pivotally connected to frame 402. Though not illustrated, a push-pull cable mechanically links locking member 420 to rear caster 414 or its parallel equivalent in the same fashion as that shown in FIG. 4. The operation of embodiment 500 is similar to that described for FIG. 4, except that when locking member 420 is in the locked state, it prevents link 502 from displacement. This, in turn, prevents either pivot arm 404 or 510 from movement.

Referring now to FIGS. 6A and 6B, an embodiment 600 of a stabilization system having ratchet-type locking member or assembly 602 is shown. The locking member 602 has a pawl member 614, ratchet member 620, and a solenoid actuator 608. Pawl member 614 and solenoid actuator 608 are rigidly fixed to frame 402 via a bracket 606. Bracket 606 also serves as a guide bracket for ratchet member 620, though this function can be provided by a separate guide member. Solenoid actuator 608 has a coil 124, spring 612 and pin 613. Pawl member 614 has a first portion pivotally connected to bracket 606 and a second portion pivotally connected to pin 613. Ratchet member 620 has a plurality of cammed extensions 622 between which pawl member 614 is configured to engage and disengage. A bottom portion of ratchet member 620 is pivotally connected to pivot arm 404 at connection 604. So configured, ratchet member 620 is free to undergo reciprocating movement within the guide portion of bracket 606 as pivot arm 404 pivots about connection

8

406. As described earlier, solenoid actuator 608 can be controlled by any of the embodiments of FIGS. 1-4.

As such, when the wheelchair exhibits a tipping behavior, solenoid actuator 608 is de-energized causing spring 612 to urge pin 613 and pawl member 614 against ratchet member 620. This causes pawl member 614 to be locked against ratchet member 620 so as to prevent ratchet member 620 from any further upward motion, which causes tipping of the wheelchair. This state prevents the forward portion of pivot arm 404 from exhibiting any upward motion that is associated with the wheelchair's tipping behavior. However, it may be desirable to allow ratchet member 620 to further move in the downward direction while pawl member 614 remains engaged therewith. This is accomplished by appropriately camming the engaging surfaces of pawl member 614 and ratchet member 620, as shown. In this manner, pivot arm 404 is free to move in a direction that would lessen the tipping behavior of the wheelchair but not increase such behavior. If the wheelchair is not exhibiting a tipping behavior or has ceased to exhibit a tipping behavior, solenoid actuator 608 is energized causing pin 613 and pawl member 614 to disengage from ratchet member 620. This allows pivot arm 404 to freely pivot about connection 406. As described earlier in connection with FIGS. 4 and 5, one or two or more locking members can be provided. Additionally, pawl member 614 can be triggered by an inertial switch or method instead of solenoid actuator 608 or one which actuates a solenoid actuator.

Referring now to FIGS. 7A and 7B, an embodiment 700 of a stabilization system having a caliper-type locking member or assembly 702 is shown. The locking member 702 has a spring 712, pin 714, one or more friction plates 710, and a linear reciprocating link 704. Pin 714 has a first portion connected to friction plate 710 and a second portion connected to either a solenoid actuator or push-pull cable, or equivalent, as described earlier for locking and unlocking the suspension system. Spring 712 is located between these portions and biases pin 714 and friction plate 710 toward link 704. The friction plates 710, spring 712, and pin 714 are housed within a frame attachment 708, which rigidly connects these components to frame 402. Attachment 708 also functions as a guide for link 704 so as to always maintain link 704 between friction plates 710. This function can also be provided by a separate guide bracket.

Link 704 has a first portion that is pivotally connected to pivot arm 404 and a second portion that travels within attachment or guide 708 so as to be engageable by friction plates 710. In this manner, as pivot arm 404 rotates about connection 406, link 704 exhibits a reciprocating up and down motion with respect to attachment 708 and friction plates 710. Preferably, two friction plates 710 are provided facing each other with a gap therebetween. The space or gap exists between friction plates 710 so as to allow link 704 to freely move therethrough until such time as the friction plate 710 connected to pin 714 is moved toward link 704 and the opposing friction plate 710. This movement causes both friction plates 710 to engage the link 704 and to lock it in position. This, in turn, prevents pivot arm 404 from pivoting about connection 406. Hence, when the wheelchair is exhibiting a tipping behavior, pin 714 is extended allowing friction plate 710 to engage against link 704. When link 704 is locked between friction plates 710, the wheelchair will not exhibit any tipping behavior. When the conditions for a tipping behavior are absent, pin 714 is in its retracted position and link 704 can move freely between friction plates 710.

Referring now to FIGS. 8A, 8B, and 8C, an embodiment 800 of a stabilization system having a magnetic-field action-

able locking member is shown. Referring specifically to FIG. 8C, embodiment 800 has a locking member 804 and an actuator assembly 802 associated therewith. Locking member 804 has a first portion 806 that is pivotally connected to pivot arm 404 and a second portion 808 that is pivotally connected to frame 402. Locking member 802 is a hydraulic piston assembly having a magnetic fluid. The piston within the assembly has a valve that allows the fluid to pass from one side of the piston to the other. However, when a magnetic field is brought near the proximity of the fluid, the magnetic field causes the fluid viscosity to greatly increase thereby not allowing the fluid to flow through the valve in the piston. This, in turn, locks the piston in position.

Illustrated in FIG. 8A is a first embodiment of the actuator assembly 802. The assembly 802 has a permanent magnet 810 that is fixed directly or indirectly to frame 802, a solenoid coil 812 and a switch 814. Solenoid coil 812 can be the same component as solenoid coil 124 and switch 814 can be mechanical or electronic, as described in connection with FIGS. 1-4. In operation, magnet 810 causes the fluid in locking member 804 to have a very high viscosity and, hence, almost no ability to flow. This maintains locking member 804 in a locked state thereby locking pivot arm 404 from pivoting about connection 406. However, when solenoid coil 812 is energized by switch 814, its magnetic field cancels with the magnetic field generated by magnet 810 and allows the fluid in locking member 812 to have a very low viscosity and, hence, the ability to flow relatively easily. This allows locking member 804 to move in accordance with the movement of pivot arm 404 about pivotal connection 406. Hence, if power is lost, magnet 810 provides a failsafe condition which automatically locks locking member 804. Therefore, it can be seen that when the wheelchair exhibits a tipping behavior, solenoid coil 812 is de-energized causing locking member 804 to lock pivot arm 404. When no tipping behavior is exhibited by the wheelchair, solenoid coil 812 is energized and locking member 804 is not in its locked state.

Illustrated in FIG. 8B is a second embodiment of an actuator assembly 802. This embodiment has the earlier described push-pull cable 424 spring-loaded against magnet 810. In this embodiment magnet 810 moves either toward or away from the locking member 804 so as to either bring its magnetic field in operative proximity to the locking member or away from the locking member. As described in connection with FIG. 4, push-pull cable 424 provides for linear mechanical movement upon a tipping condition of the wheelchair. By having push-pull cable 424 fixed to magnet 810, the linear movement of push-pull cable 424 can be used to move magnet 810 closer to locking member 804 so as to place it in its locked state, or away from locking member 804 so as to place it in its unlocked state. Spring is also provided so as to bias magnet 810 towards locking member 804 ensuring that locking member 804 is in its locked state should push-pull cable 424 break.

Referring now to FIG. 9, an embodiment 900 of a suspension system having a sprag clutch locking member 902. Sprag clutch locking member 902 allows rotational movement in one direction and not in the other. Alternatively, locking member 902 can be a bi-directional clutch. Bi-directional clutches allow their input to drive their output in either rotational directions, but do not allow the output to drive the input.

FIGS. 10A, 10B and 10C illustrate one embodiment 1000 of a suspension system having a direct acting pin locking member 1002. Locking member 1002 extends and retracts its pin 1008 so as to enter one of a plurality of slots or

apertures in locking bracket 1004. In this regard, locking member 1002 has a spring-loaded pin 1008 and an actuator cable 1006. If locking member 1002 is mechanical, then actuator cable 1006 can be a push-pull cable, as described earlier. If locking member 1002 is solenoid driven, then actuator cable 1006 can be an electric cable that carries the signal that actuates the solenoid. The locking member 1002 can also be pneumatically actuated through known means. So configured, locking member 1002 is affixed to the frame 402 through mounting brackets (not shown) or its housing.

Locking bracket 1004 is affixed to pivot arm 404 and moves therewith. In this regard, locking bracket 1004 preferably includes an arcuate shape so as to maintain alignment with locking member 1002 as pivot arm 404 pivots or rotates. Locking bracket 1004 includes a plurality of apertures or slots that disposed along the bracket's arcuate body. The apertures can be any shape such that pin 1008 can enter thereinto. Pivot arm 510 (not shown) would have a similar suspension system.

Illustrated in FIG. 10C is detail of an alternative embodiment of pin 1008. More specifically, FIG. 10B shows pin 1008 having flat head portion at its engaging distal end. FIG. 10C shows an embodiment of pin 1008 having a cammed surface 1010 at its engaging distal end. Cammed surface 1010 is provided so that when pin 1008 is engaged in locking bracket 1004, pivot arm 404 can pivot in the downward direction. This causes a ratcheting effect where cammed surface 1010 causes pin 1008 to retract under the downward tendency (i.e., clockwise rotation) of pivot arm 404. However, configured as such, pin 1008 does not allow a corresponding ratcheting in the upward direction (i.e., counter-clockwise rotation) of pivot arm 404.

In operation, pin 1008 of locking member 1002 is spring-engaged into an aperture of locking member 1004. Actuator cable 1006, when active, causes pin 1008 to retract from locking bracket 1004. In this manner, a failsafe configuration is provided should actuator cable 1006 fail. The triggering of locking member 1002 can be by any of the embodiments described in FIGS. 1-4.

Illustrated in FIGS. 11A and 11B an embodiment 1100 of a suspension system having an axial spring locking member 1002. In particular, locking member 1102 has an actuator member 1108. Actuator member 1108 can be a spring-loaded pin, solenoid driven pin, or a mechanical clamp (not shown). Actuator member 1108 is actuated by an actuator cable 1110, which can be an electric cable, pneumatic hose, or push-pull cable. Locking member 1102 further has a housing 1112 that includes a spring 1113 that axially receives a locking rod or tube 1106 therein. Locking member 1102 is rigidly affixed to frame 402 with mounting brackets (not shown).

Spring 1113 is a coil spring that includes first and second extensions 1114 and 1116, respectively. Spring 1113 is arranged so that when extensions 1114 and 1116 are not acted upon by any force, spring 1113 is tightly coiled around locking rod or tube 1106 so as to prevent any axially movement of locking rod or tube 1106 within spring 1113. Since locking rod or tube 1106 has one of its distal ends pivotally fixed to pivot arm 404 at 1104, pivot arm 404 is also locked from any rotational movement. In this manner, a failsafe configuration is provided should actuator cable 1110 fail. The triggering of locking member 1102 can be by any of the embodiments described in FIGS. 1-4.

To release locking rod or tube 1106 from spring 1113, extensions 1114 and 1116 are acted upon by a force. In this regard, extensions 1114 and 1116 can be configured so that either a force that brings them closer together or a force that

11

brings them farther apart causes spring 1113 to become loosely coiled around locking rod or tube 1106. Once loosely coiled, spring 1113 allows locking rod or tube 1106 to axially move therein. This, in turn, allows pivot arm 404 to pivot about its connection at 403. Pivot arm 510 (not shown) would have a similar suspension system.

Referring now to FIGS. 12A, 12B, 12C, 12D, and 12E, an embodiment of a suspension system 1200 having an linear locking member 1202 is shown. FIG. 12A shows the suspension system on a level driving surface. FIG. 12B illustrates the suspension system wherein front caster 412 is lifted by the suspension off of the driving surface. FIG. 12C shows the suspension system wherein front caster 412 has been lowered onto a lower driving surface. FIG. 12D illustrates the suspension 1200 with the drive wheel removed and FIG. 12E is a partial perspective view of the suspension 1200.

Suspension system 1200 further includes a four-bar pivoting assembly that includes pivot arms 1204A and 1204B, caster head tube bracket 1214, and frame 402. Bracket 1208, while a separate component, can be considered as part of frame 402. Pivot arms 1204A and 1204B are pivotally connected to frame 402 via pivotal connections 1206A and 1206B. Pivot arms 1204A and 1204B are also pivotally connected to caster head tube bracket 1214 via pivotal connections 1207A and 1207B.

Locking member 1202 is shown having a first pivotal connection 1210 to pivot arm 1204B and a second pivotal connection 1212 to bracket 1208. So connected locking member is under the influence of pivot arms 1204A and 1204B. It should be noted that locking member 1202 pivotal connection 1210 can be alternatively located on pivot arm 1204A or caster head tube bracket 1214, as well.

FIG. 12F illustrates a partial cross-section of locking member 1202. Locking member 1202 has a first housing 1220 and a second housing 1222. First housing 1220 retains therein an electric solenoid actuator 1230 that includes a coil and a plunger 1232 biased by leaf spring 1228. A cover 1226 is provided on housing 1220 that has an aperture that allows plunger 1232 to at least partially project there from. The projecting portion of plunger 1232 has a pivotable lever 1224 connected thereto. Pivoting of the lever through manual actuation causes plunger 1232 to move without the need for electrical energy.

Second housing 1222, which is attached to first housing 1220 includes a channel or passage 1234 therein. A rod member 1236 moves within passage 1234 and includes a notch 1238 therein. Notch 1238 is configured such that when plunger 1232 is biased into passage 1234, plunger 1232 will come into locking engagement with notch 1238 and remain there until withdrawn. Alternatively, notch 1238 can be replaced by a ratcheting tooth configuration similar to that shown in FIG. 6B.

Referring now to FIGS. 12G and 12H, perspective and top views of locking member 1202 are illustrated. Rod member 1236 includes at one distal end an aperture 1240, which accepts a pin or similar fastener in forming pivotal connection 1210. Additionally, second housing 1222 includes at one distal end first and second extensions 1246 and 1248, each of which have aligned apertures 1244. Extension 1246 and 1248 accept in the space between them a pivoting bracket member that is used secure the locking member 1202 to bracket 1208.

Illustrated in FIG. 12I is an exploded perspective view of locking member 1202. In addition to the above-mentioned components, locking member 1202 further includes a block 1252 that is affixed to plunger 1232. Block 1252 increases

12

the effective cross-section of plunger 1238 which is responsible for locking engagement with rod member 1236. Housing 1222 has a cover portion 1250 that includes an aperture 1254 having substantially the same shape as block 1252 and allows block 1252 to reciprocate there within.

In operation, locking member 1202 locks the suspension system when, for example, the vehicle is not moving and motor parking brake or lock is actuated. This creates a stable platform for the user to transport in and out of the vehicle or wheelchair. Locking member 1202 is also preferably configured to lock suspension system when the is no power or the power system has been shut off. This is achieved by always biasing plunger 1232 into locking engagement with rod member 1236. Upon power-up, solenoid 1230 is actuated and plunger 1232 is withdrawn from the locking engagement.

So configured, locking member 1202 can be alternatively located among a plurality of positions the on suspension system 1200. For example, locking member 1202 can be attached between the frame 402 and upper pivot arm 1204A, attached between the upper and lower pivot arms 1204A and 1204B, or between any two components of the described four-bar pivoting assembly. Additionally, locking member 1202 can be triggered by any of the mechanisms described earlier electrical or mechanical.

Illustrated in FIG. 13 is an eighth embodiment of a locking assembly of the present invention. The locking assembly has a motor rack bracket 1314, first ratchet 1320, second ratchet 1322 and a spring mount 1318. So configured, the locking assembly is shown mounted on the vehicle frame 402, which includes a four-bar linkage pivoting front caster assembly. The four-bar linkage pivoting caster assembly includes first and second linkages 1302 and 1304. A third linkage is provided by frame 402 and its extension in the form of frame bracket 1306. A fourth linkage is provided by caster head tube assembly 1311. First linkage 1302 is pivotally connected to frame 402 at pivot 1310 and second linkage 1304 is pivotally connected to frame 402 at pivot 1308. A more detailed discussion of this four-bar linkage pivoting front caster assembly can be found in pending U.S. patent application Ser. No. 09/974,348, filed on Oct. 10, 2001, which is hereby fully incorporated by reference.

The locking assembly's motor rack bracket 1314 is physically connected to first linkage 1302 through a motor/gearbox mount 1312. The connection can also be made directly if desired. A gearbox 1316 is also shown connected to motor/gearbox mount 1312. First ratchet 1320 is attached to motor rack bracket 1314 at an end portion opposite the connection to first linkage 1302. So configured, motor rack bracket 1314 pivots when first linkage 1302 pivots.

The locking assembly's spring mount 1318 is pivotally connected to frame 402 through clevis 1325. The second ratchet 1322 is affixed to a side portion of the spring mount 1318. Clevis 1325 and its pivotal connection 1324 allow spring mount 1318 to pivot with respect to frame 402. In an alternate embodiment, pivotal connections 1324 and 1332 and devises 1325 and 1334 can be combined into a single integrated clevis and pivotal connection. For example, clevis 1325 can be eliminated and pivotal connection 1324 integrated into pivotal connection 1332.

In another embodiment, an elastic member such as, for example, a spring, can be positioned between spring mount 1318 and frame 402. Such a spring would urge or assist the pivotal movement of spring mount 1318 away from frame 402, as will be described below. To facilitate such a spring, spring mount 1318 would include a bearing surface for

13

bearing against one end of the spring and a spring holder. This configuration can take the form of pin or bolt at least partially received within the spring, which such configuration may additionally be at least partially received within a recess in spring mount 1318. The other end of the spring would bear against a bearing surface on frame 402. Alternatively, such a configuration can be reversed between the spring mount 1318 and frame 402.

A rear caster mount 1328 pivotally connects rear caster 414 to frame 402. More specifically, rear castor mount 1328 has an extension 1330 that includes a first distal end pivotally connected to clevis 1334 and a second distal end connected to a head tube portion for mounting the rear caster 414. A spring 1326 is situated between rear castor mount 1328 and spring mount 1318. Spring 1326 compresses when rear castor mount 1328 pivots clockwise as shown in FIG. 13 toward frame 402. In this manner, spring 1326 provides a degree of suspension for the rear castor mount 1328. Alternatively, if no degree of suspension is desired, spring 1326 can be replaced by a non-resilient member resulting in spring mount 1318 and rear castor mount 1328 being an integrated and rigid structure. As described above, such an integrated structure can employ a single integrated pivot at pivotable connection 1332, as opposed to pivotable connections at 1324 and 1332.

In operation, first and second ratchets 1320 and 1322 engage each other whenever rear caster 414 is about to be lifted from its supporting surface. The condition occurs whenever the frame 402 pivots or tilts forward toward front caster 412. When frame 402 pivots or tilts forward, first and second pivot arm linkages 1302 and 1304 correspondingly pivot about their pivotal connection 1310 and 1308, respectively. Any pivotal movement of linkages 1302 or 1304 translates to pivotal movement of motor rack bracket 1314 and first ratchet 1320 by virtue of their mechanical coupling. As this condition occurs, rear castor mount 1328 pivots about its pivotal connection at 1332 causing spring mount 1318 to pivot about its pivotal connection at 1324 so that second ratchet 1322 comes into contact with first ratchet 1320. When first and second ratchets 1320 and 1322 come into contact, pivot arm linkages 1302 and 1304 are locked thereby locking frame 402 from any additional pivoting or tilting forward. When frame 402 resumes its normal level position, rear castor mount 1328 pivots clockwise causing spring mount 1318 to pivot clockwise and disengage second ratchet 1322 from first ratchet 1320. This releases first and second pivot arm linkages 1302 and 1304 so that they may once again freely pivot.

FIGS. 14 through 16, further illustrate the locking assembly and its components in perspective views. In particular, FIG. 15 is a perspective view of the spring mount 1318. Spring mount 1318 further has a surface 1502 for bearing against spring 1326 and a structure 1504 holding spring 1326 in position relative spring mount 1318. FIG. 16 is a perspective view of rear castor mount 1328. Rear castor mount 1328 further has a surface 1602 for bearing against spring 1326 and a structure 1604 for holding spring 1326 in position relative to rear castor mount 1328.

Referring now to FIGS. 17A and 17B, elevational and perspective views, respectively, of the second ratchet 1322 are illustrated. Second ratchet 1322 has a body 1702 that includes a plurality of mounting apertures 1706 that are used to fasten it to spring mount 1318. Body 1702 also includes a toothed surface 1704. Surface 1704 is slightly curved to compensate for the nature of the pivotal motion first ratchet 1320 experiences as it pivots with pivot arm linkages 1302 and 1304.

14

FIGS. 18A and 18B are elevational and perspective views, respectively, of first ratchet 1320. First ratchet 1320 has a body 1804 that includes a plurality of mounting apertures 1806, which are used to fasten first ratchet 1320 to motor rack bracket 1314. Body 1804 also has a toothed surface 1804, which is slightly curved to accommodate the pivotal motion experienced by second ratchet 1322. The tooth configuration of surfaces 1804 and 1704 are configured such that relative motion between first and second ratchets 1320 and 1322 is more or less permitted in one direction, but motion in the opposite direction is impeded.

While the present invention has been illustrated by the description of embodiments thereof, and while the embodiments have been described in considerable detail, it is not the intention of the applicant to restrict or in any way limit the scope of the appended claims to such detail. Additional advantages and modifications will readily appear to those skilled in the art. For example, pivotal connections can be made of any number of structures including bearing assemblies, pins, nuts and bolts, and frictionless sleeve assemblies. Additionally, springs or shock absorbers can be added between pivoting and non-pivoting components to limit, dampen, or somewhat resist the pivotal motions of these components. Also, a brake-disc locking mechanism could be integrated into pivotal connection 406 that locks pivotal connection 406 from rotation when actuated and freely allows pivotal motion about connection 406 when not actuated. Therefore, the invention, in its broader aspects, is not limited to the specific details, the representative apparatus, and illustrative examples shown and described. Accordingly, departures can be made from such details without departing from the spirit or scope of the applicant's general inventive concept.

What is claimed:

1. A suspension for a vehicle comprising:
 - a frame;
 - a releasable locking assembly comprising:
 - a first assembly movably coupled to the frame;
 - a second assembly movably coupled to the frame;
 wherein movement of the frame relative to the first and second assemblies causes the first and second assemblies to engage each other to limit further movement of the frame in at least a first direction.
2. The suspension of claim 1 wherein the first assembly is pivotably coupled to the frame.
3. The suspension of claim 1 wherein the second assembly is pivotably coupled to the frame.
4. The suspension of claim 1 wherein the first assembly comprises a first undulating portion.
5. The suspension of claim 4 wherein the second assembly comprises a second undulating portion.
6. The suspension of claim 5 wherein the second undulating portion comprises a toothed surface.
7. The suspension of claim 5 wherein the second undulating portion comprises a stepped surface.
8. The suspension of claim 4 wherein the first undulating portion comprises a toothed surface.
9. The suspension of claim 4 wherein the first undulating portion comprises a stepped surface.
10. The suspension of claim 1 further comprising a caster coupled to the second assembly.
11. The suspension of claim 1 wherein the second assembly comprises a first portion and a second portion and a resilient member between the first and second portions.
12. The suspension of claim 11 wherein the first portion and the second portion are coupled to the frame at a first location.

15

13. The suspension of claim 11 wherein the first portion is coupled to the frame at a first location and the second portion is coupled to the frame at a second location.

14. The suspension of claim 11 wherein the first portion is pivotably coupled to the frame at a first location and the second portion is pivotably coupled to the frame at a second location.

15. The suspension of claim 1 wherein the first assembly's moveably coupling to the frame comprises a mounting to a pivot arm movably coupled to the frame.

16. The suspension of claim 1 wherein movement of the frame in a first direction is limited by engagement of the first and second assemblies and wherein movement in a second direction is not limited by engagement of the first and second assemblies.

17. The suspension of claim 1 wherein pivotal movement of the second assembly causes the second assembly to come into engagement with the first assembly to limit the movement of the first assembly.

18. A suspension for a vehicle comprising:
a frame;

a locking assembly comprising:
a first member coupled to the frame, the first member having a first undulating portion;
a second member coupled to the frame, the second member having a second undulating portion; and
wherein movement of the frame relative to the first and second members causes the first and second members to physically engage each other to limit further movement of the frame in at least a first direction.

19. The suspension of claim 18 wherein the first undulating portion comprises a toothed surface.

20. The suspension of claim 19 wherein the second undulating portion comprises a toothed surface.

21. The suspension of claim 19 wherein the second undulating portion comprises a stepped surface.

22. The suspension of claim 18 wherein the first undulating portion comprises a stepped surface.

23. The suspension of claim 18 wherein movement of the frame relative to the first and second members causes the first and second undulating portions to engage each other to limit further movement of the frame in at least a first direction.

24. A suspension for a vehicle comprising:
a frame;

at least one pivot arm coupled to the frame; the pivot arm comprising a caster assembly coupled thereto;
a first member coupled to the pivot arm;
a second member movably coupled to the frame; and
wherein movement of the frame relative to the first and second members causes the first and second members to physically engage each other to limit further movement of the frame in at least a first direction.

25. The suspension of claim 24 wherein the second member is pivotably coupled to the frame.

26. The suspension of claim 24 wherein the first assembly comprises a first undulating portion.

27. The suspension of claim 26 wherein the second assembly comprises a second undulating portion.

28. The suspension of claim 27 wherein the second undulating portion comprises a toothed surface.

29. The suspension of claim 27 wherein the undulating surface comprises a stepped surface.

30. The suspension of claim 26 wherein the first undulating portion comprises a toothed surface.

31. The suspension of claim 26 wherein the undulating surface comprises a stepped surface.

16

32. The suspension of claim 24 further comprising a caster coupled to the second assembly.

33. The suspension of claim 24 wherein the second member comprises a first portion and a second portion and a resilient member between the first and second portions.

34. The suspension of claim 33 wherein the first portion and the second portion are coupled to the frame at a first location.

35. The suspension of claim 33 wherein the first portion is coupled to the frame at a first location and the second portion is coupled to the frame at a second location.

36. The suspension of claim 33 wherein the first portion is pivotably coupled to the frame at a first location and the second portion is pivotably coupled to the frame at a second location.

37. The suspension of claim 24 wherein movement of the frame in a first direction is limited by engagement of the first and second members and wherein movement in a second direction is not limited by engagement of the first and second members.

38. The suspension of claim 24 wherein pivotal movement of the second member causes the second member to come into engagement with the first member to limit the movement of the first assembly.

39. A suspension for a vehicle comprising:
a frame;

at least one pivot arm coupled to the frame; the pivot arm comprising a caster assembly coupled thereto;
a first assembly coupled to the pivot arm;
a second assembly pivotably coupled to the frame; and
wherein movement of the frame causes the second assembly to exhibit pivotal motion so as to engage the first assembly to limit further movement of the frame in at least a first direction.

40. The suspension of claim 39 wherein the first assembly comprises a first undulating portion.

41. The suspension of claim 40 wherein the second assembly comprises a second undulating portion.

42. The suspension of claim 41 wherein the second undulating portion comprises a toothed surface.

43. The suspension of claim 41 wherein the undulating surface comprises a stepped surface.

44. The suspension of claim 40 wherein the first undulating portion comprises a toothed surface.

45. The suspension of claim 40 wherein the undulating surface comprises a stepped surface.

46. The suspension of claim 39 further comprising a caster coupled to the second assembly.

47. The suspension of claim 39 wherein the second assembly comprises a first portion and a second portion and a resilient member between the first and second portions.

48. The suspension of claim 47 wherein the first portion and the second portion are coupled to the frame at a first location.

49. The suspension of claim 47 wherein the first portion is coupled to the frame at a first location and the second portion is coupled to the frame at a second location.

50. The suspension of claim 47 wherein the first portion is pivotably coupled to the frame at a first location and the second portion is pivotably coupled to the frame at a second location.

51. The suspension of claim 39 wherein movement of the frame in a first direction is limited by engagement of the first and second assemblies and wherein movement in a second direction is not limited by engagement of the first and second assemblies.

17

52. The suspension of claim 39 wherein pivotal movement of the second assembly causes the second assembly to come into engagement with the first member to limit the movement of the first assembly.

53. A suspension for a vehicle comprising:
a frame;
at least one pivot arm coupled to the frame; the pivot arm comprising a first caster assembly coupled thereto;
a first assembly coupled to the pivot arm;
a second assembly pivotably coupled to the frame, the second assembly comprising a second caster assembly coupled thereto; and

wherein movement of the frame causes the second assembly to exhibit pivotal motion so as to engage the first assembly to limit any further movement of the frame.

54. A suspension for a vehicle comprising:
a frame;
at least one pivot arm coupled to the frame;
at least one front caster coupled to the pivot arm;
at least one drive wheel coupled to the pivot arm;
a first assembly coupled to the pivot arm, the first assembly comprising a substantially vertically oriented first undulating surface;
a second assembly pivotably coupled to the frame, the second assembly comprising a substantially vertically oriented second undulating surface disposed laterally proximate the first undulating surface; and
at least one rear caster coupled to the second assembly.

55. The suspension of claim 54 wherein movement of the frame causes the second assembly to exhibit pivotal motion so as to engage the first assembly to limit any further movement of the frame.

56. The suspension of claim 54 wherein movement of the frame causes the second undulating surface to exhibit pivotal motion so as to engage the first undulating surface to limit any further movement of the frame.

57. The suspension of claim 54 wherein the first or second undulating surfaces comprise a toothed surface.

58. The suspension of claim 54 wherein the first or second undulating surfaces comprises a stepped surface.

59. The suspension of claim 54 wherein the second assembly comprises a first portion and a second portion and a resilient member between the first and second portions.

60. The suspension of claim 59 wherein the first portion and the second portion are coupled to the frame at a first location.

61. The suspension of claim 59 wherein the first portion is coupled to the frame at a first location and the second portion is coupled to the frame at a second location.

62. The suspension of claim 59 wherein the first portion is pivotably coupled to the frame at a first location and the second portion is pivotably coupled to the frame at a second location.

63. The suspension of claim 54 wherein movement of the frame in a first direction is limited by engagement of the first and second assemblies and wherein movement in a second direction is not limited by engagement of the first and second assemblies.

18

64. An assembly for releasably locking a vehicle suspension comprising:

a first assembly movably coupled to a frame of the vehicle;
a second assembly movably coupled to the frame; and
wherein movement of the frame relative to the first and second assemblies causes the first and second assemblies to engage each other to limit any further movement of the frame.

65. The assembly of claim 64 wherein the first assembly is pivotably coupled to the frame.

66. The assembly of claim 64 wherein the second assembly is pivotably coupled to the frame.

67. The assembly of claim 64 wherein the first assembly comprises a first undulating portion.

68. The assembly of claim 67 wherein the second assembly comprises a second undulating portion.

69. The assembly of claim 68 wherein the second undulating portion comprises a toothed surface.

70. The assembly of claim 68 wherein the undulating portion comprises a stepped surface.

71. The assembly of claim 67 wherein the first undulating portion comprises a toothed surface.

72. The assembly of claim 67 wherein the undulating portion comprises a stepped surface.

73. The assembly of claim 64 wherein the second assembly comprises a first portion and a second portion and a resilient member between the first and second portions.

74. The assembly of claim 73 wherein the first portion and the second portion are coupled to the frame at a first location.

75. The assembly of claim 73 wherein the first portion is coupled to the frame at a first location and the second portion is coupled to the frame at a second location.

76. The assembly of claim 73 wherein the first portion is pivotably coupled to the frame at a first location and the second portion is pivotably coupled to the frame at a second location.

77. The assembly of claim 64 wherein the first assembly's moveably coupling to the frame comprises a mounting to a pivot arm movably coupled to the frame.

78. The assembly of claim 64 wherein movement of the frame in a first direction is limited by engagement of the first and second assemblies and wherein movement in a second direction is not limited by engagement of the first and second assemblies.

79. The assembly of claim 64 wherein pivotal movement of the second assembly causes the second assembly to come into engagement with the first assembly to limit the movement of the first assembly.

80. An assembly for releasably locking a vehicle suspension comprising:

a first means for locking;
a second means for locking;
a means for moveably mounting the first and second means for locking to a vehicle frame; and

wherein movement of the frame relative to the first and second means for locking causes the first and second means for locking to come into inter-engagement with each other to restrict any further movement of the frame in at least a first direction.

* * * * *