



[54] METHOD AND APPARATUS FOR RECEIVING A PLURALITY OF SIGNALS HAVING DIFFERENT FREQUENCY BANDWIDTHS

5,835,845 11/1998 Niki et al. 455/5.1
5,852,772 12/1998 Lampe et al. 455/226.2

FOREIGN PATENT DOCUMENTS

2233520 1/1991 United Kingdom H03D 7/16

OTHER PUBLICATIONS

Stephen J. Erst, Tunable crystal filter accepts any frequency, MICROWAVES, vol. 17, No. 11, p. 94, Nov., 1978.

Primary Examiner—Andrew I. Faile
Assistant Examiner—Habte Bahgi
Attorney, Agent, or Firm—Romi N. Bose

[75] Inventors: Christopher R. Bach, Elgin; Patrick D. Smith, Schaumburg, both of Ill.

[73] Assignee: Motorola, Inc., Schaumburg, Ill.

[21] Appl. No.: 09/065,313

[22] Filed: Apr. 23, 1998

[51] Int. Cl.⁷ H04H 1/00

[52] U.S. Cl. 455/3.1; 348/7; 455/207; 455/249.1; 455/307; 455/313; 455/339; 455/340

[58] Field of Search 348/7, 12, 13, 348/731; 455/5.1, 4.2, 3.1, 307, 314, 339, 340, 350, 315, 295, 249.1, 313, 207, 266; H04N 7/173

[56] References Cited

U.S. PATENT DOCUMENTS

5,270,824 12/1993 Dobrovolny 358/191.1
5,812,928 9/1998 Watson, Jr. et al. 455/5.1
5,835,844 11/1998 Stoneback et al. 455/5.1

[57] ABSTRACT

A first mixer (306) shifts a first end (208) of a desired signal frequency bandwidth (206) of a desired signal (202) to an edge (508) of a first filter frequency bandwidth (502) of a first filter (312), wherein the first filter frequency bandwidth (502) is greater than the desired signal frequency bandwidth (206). Signals within a first undesired frequency spectrum (504) are attenuated by the first filter (314). A second mixer (316) shifts a second end (210) of the desired signal frequency bandwidth (206) to an edge (608) of a second filter frequency bandwidth (602) of a second filter (320) to receive the desired signal (202).

17 Claims, 4 Drawing Sheets

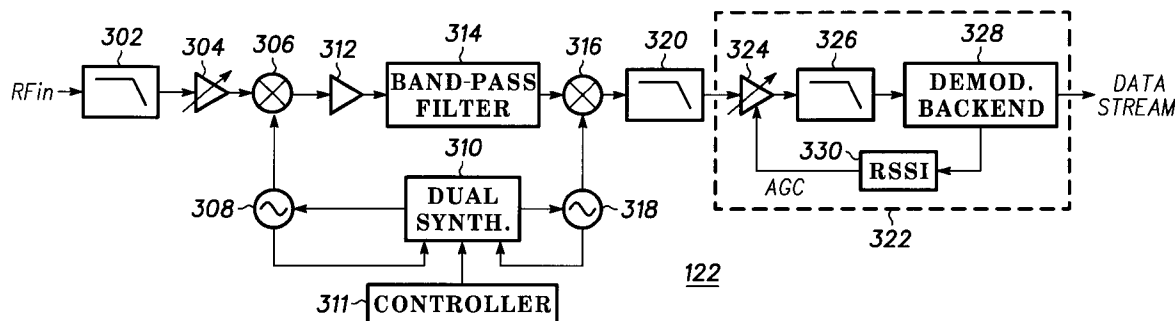

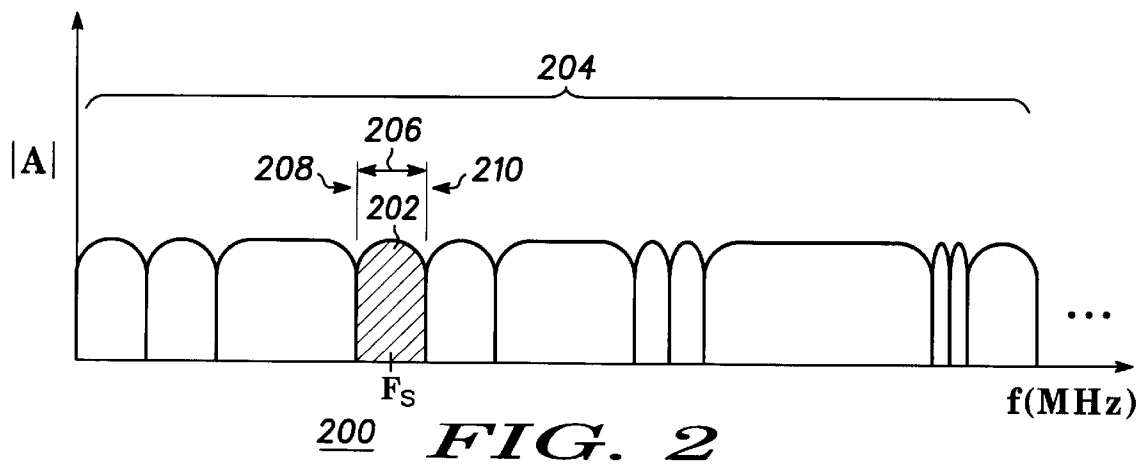
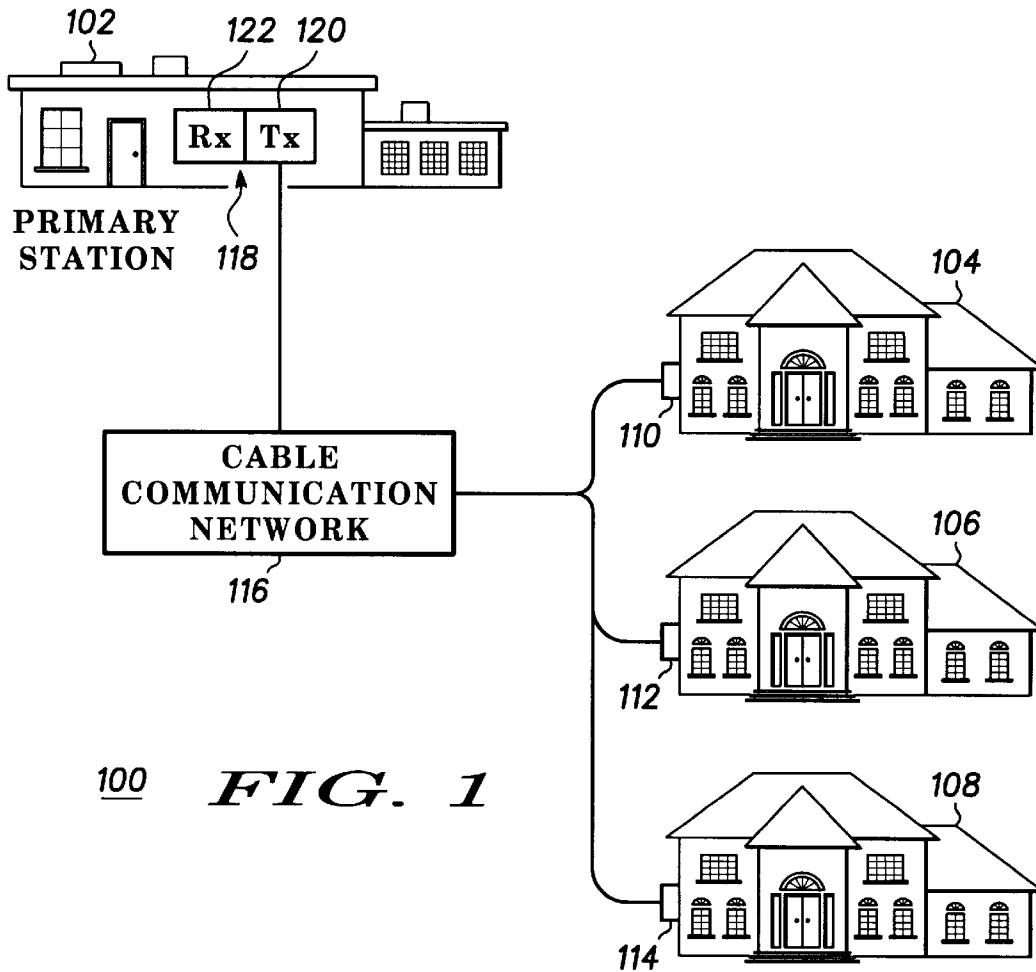

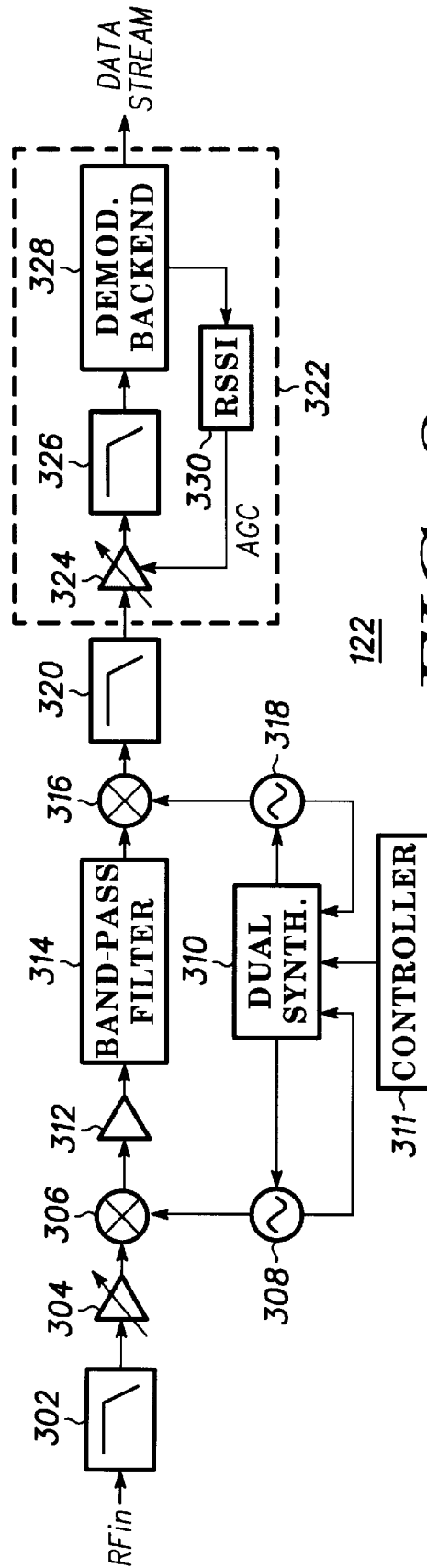

122
FIG. 3

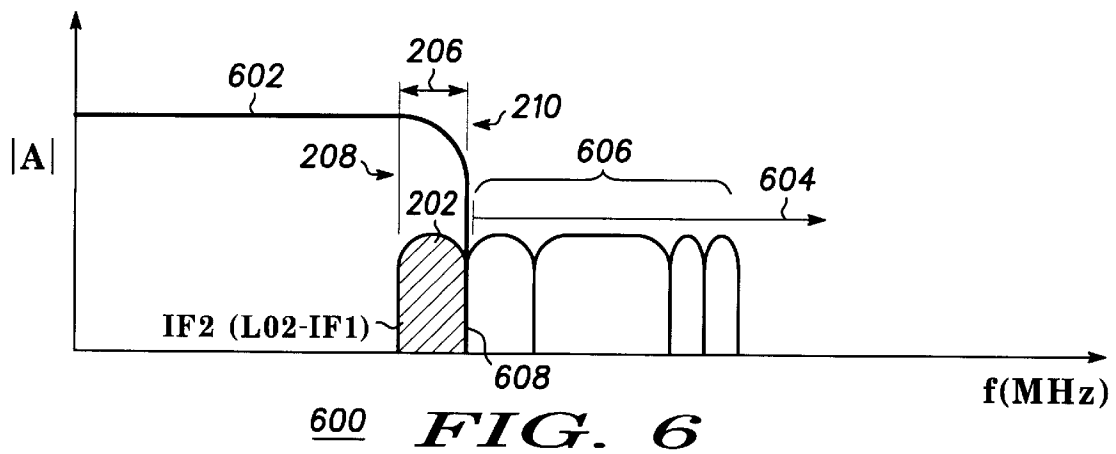
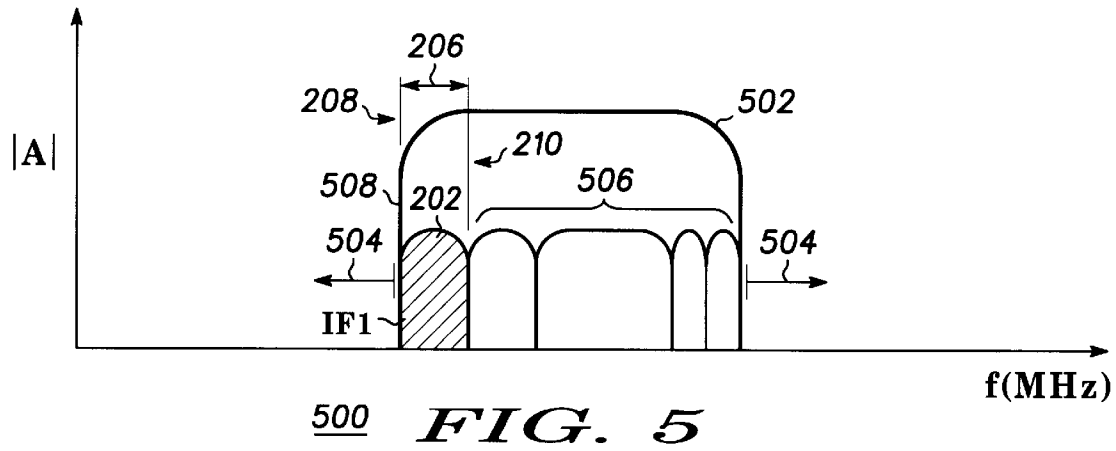
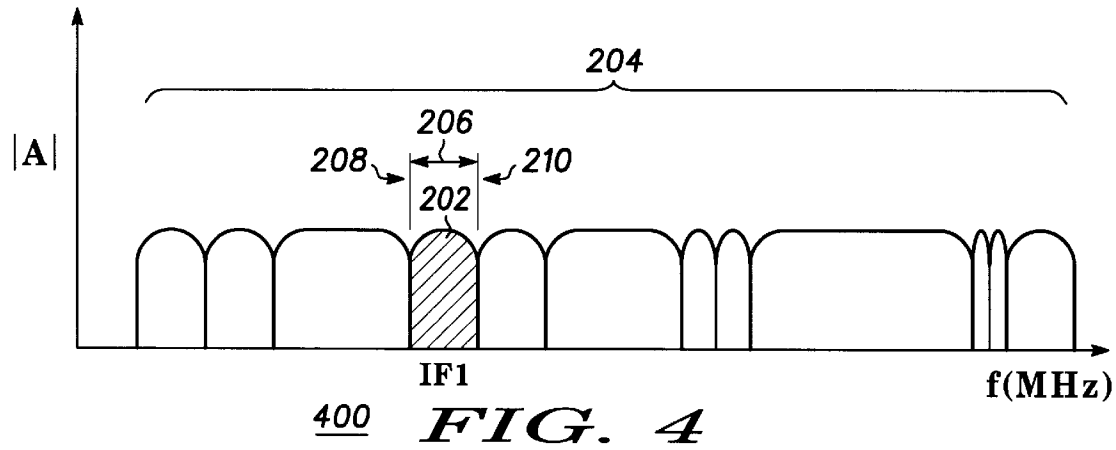

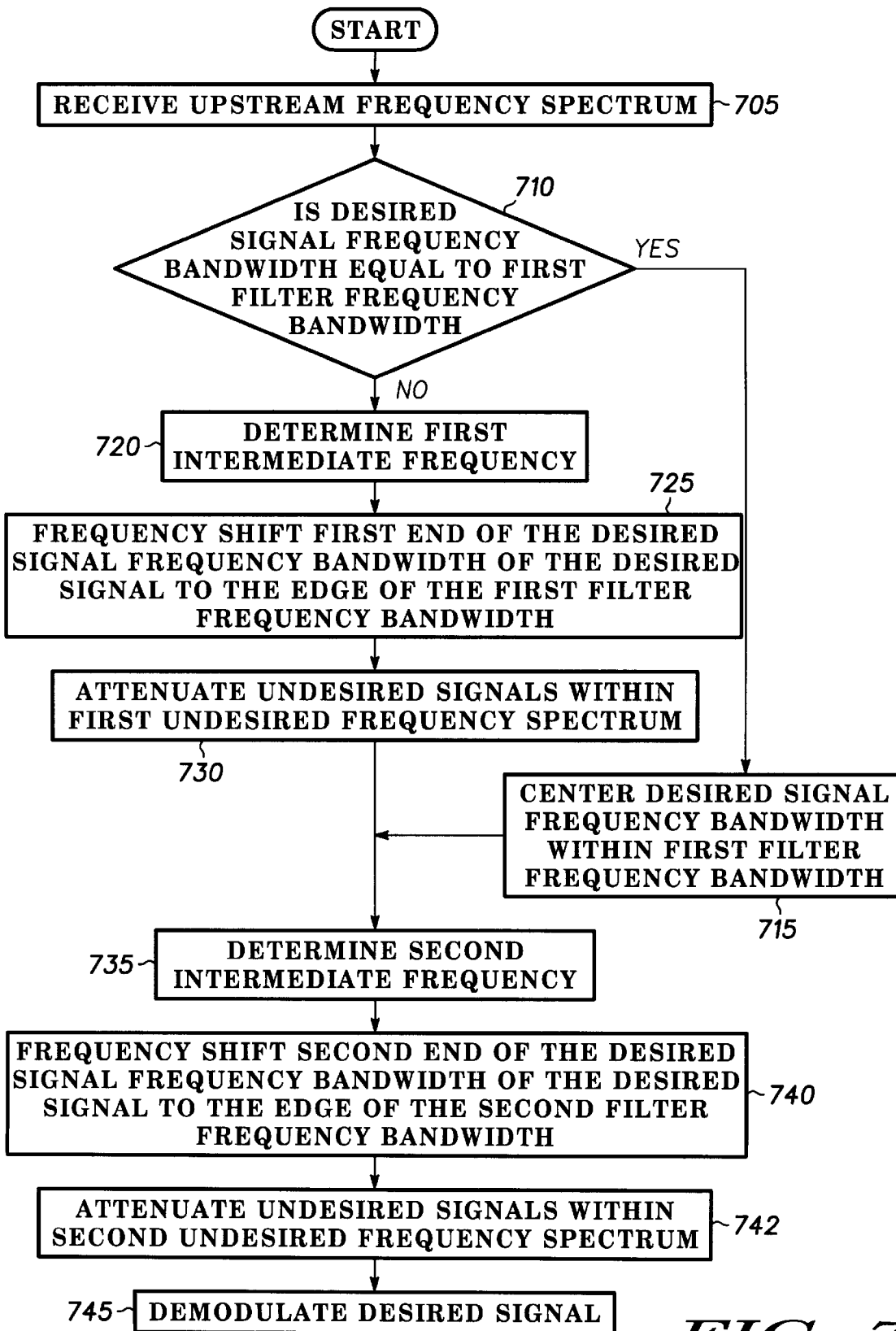

FIG. 7

Explore Litigation Insights

Docket Alarm provides insights to develop a more informed litigation strategy and the peace of mind of knowing you're on top of things.

Real-Time Litigation Alerts



Keep your litigation team up-to-date with **real-time alerts** and advanced team management tools built for the enterprise, all while greatly reducing PACER spend.

Our comprehensive service means we can handle Federal, State, and Administrative courts across the country.

Advanced Docket Research



With over 230 million records, Docket Alarm's cloud-native docket research platform finds what other services can't. Coverage includes Federal, State, plus PTAB, TTAB, ITC and NLRB decisions, all in one place.

Identify arguments that have been successful in the past with full text, pinpoint searching. Link to case law cited within any court document via Fastcase.

Analytics At Your Fingertips



Learn what happened the last time a particular judge, opposing counsel or company faced cases similar to yours.

Advanced out-of-the-box PTAB and TTAB analytics are always at your fingertips.

API

Docket Alarm offers a powerful API (application programming interface) to developers that want to integrate case filings into their apps.

LAW FIRMS

Build custom dashboards for your attorneys and clients with live data direct from the court.

Automate many repetitive legal tasks like conflict checks, document management, and marketing.

FINANCIAL INSTITUTIONS

Litigation and bankruptcy checks for companies and debtors.

E-DISCOVERY AND LEGAL VENDORS

Sync your system to PACER to automate legal marketing.