

[54] QUADRATURE DEMODULATION DATA RECEIVER WITH PHASE ERROR CORRECTION

[75] Inventor: Rodney W. Gibson, Burgess Hill, England

[73] Assignee: U.S. Philips Corporation, New York, N.Y.

[21] Appl. No.: 858,849

[22] Filed: Apr. 30, 1986

Related U.S. Application Data

[63] Continuation of Ser. No. 662,861, Oct. 19, 1984, abandoned.

[30] Foreign Application Priority Data

Oct. 21, 1983 [GB] United Kingdom 8328162

[51] Int. Cl.⁴ H03D 3/00

[52] U.S. Cl. 329/50; 329/124; 375/80; 455/214

[58] Field of Search 329/50, 122, 124; 375/80, 81, 94, 120; 455/214, 260, 264, 265

[56] References Cited

U.S. PATENT DOCUMENTS

3,971,996	7/1976	Motley et al.	328/155
4,054,838	10/1977	Tretter	375/120 X
4,359,692	11/1982	Ryan	329/50
4,521,892	6/1985	Vance et al.	329/124 X
4,570,125	2/1986	Gibson	329/50

FOREIGN PATENT DOCUMENTS

2502680	7/1976	Fed. Rep. of Germany
1529284	10/1978	United Kingdom

Primary Examiner—Siegfried H. Grimm
Attorney, Agent, or Firm—David R. Treacy

[57] ABSTRACT

A data receiver in which the phase of the carrier signal is controlled so that the threshold levels used for coherent demodulation occur at the quarter points, that is 0°, 90°, 180° and 270°. An input signal is mixed with a local oscillator signal in a pair of mixers and the outputs therefrom are low pass filtered and subsequently demodulated. Any phase errors between the local oscillator signal and the input carrier signal are corrected by a correction loop. The carrier phase error is corrected after (or downstream of) the low pass filters, so that the phase can be corrected rapidly without the risk of instability.

6 Claims, 3 Drawing Figures

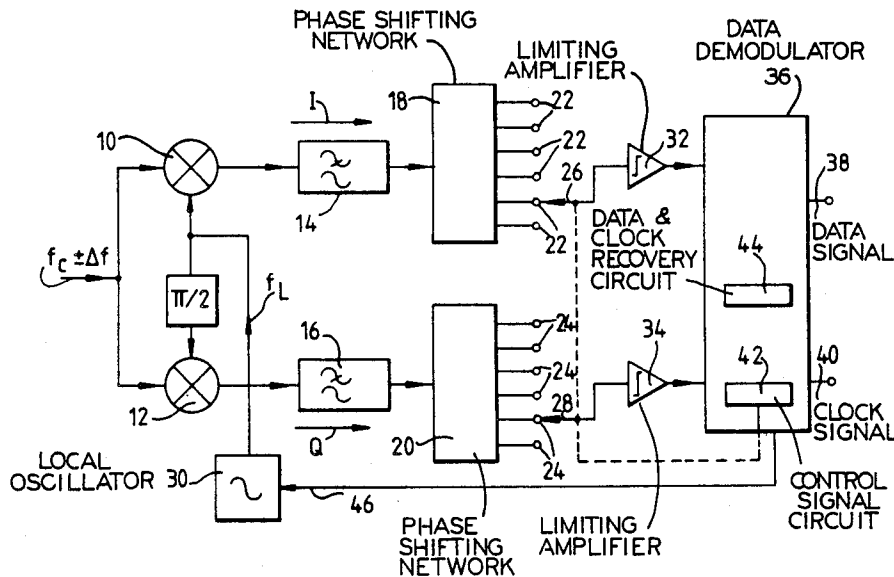

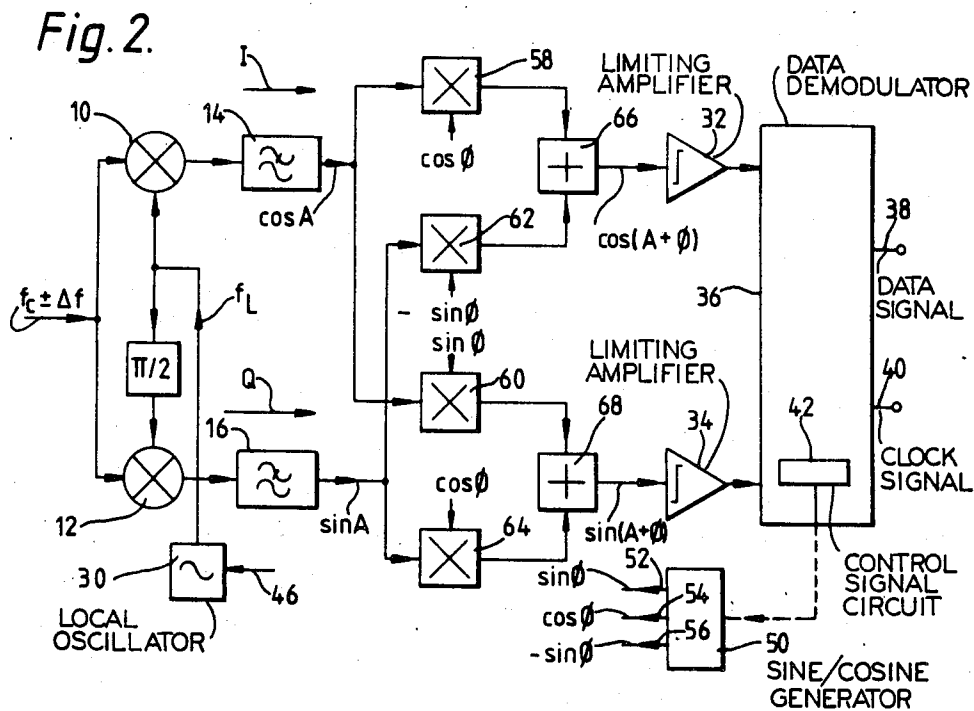
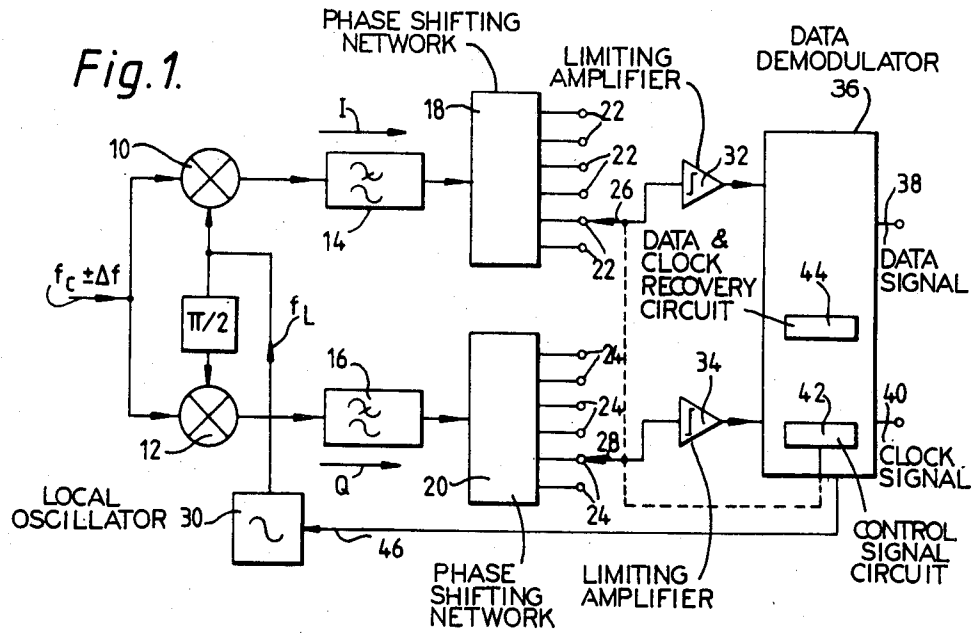
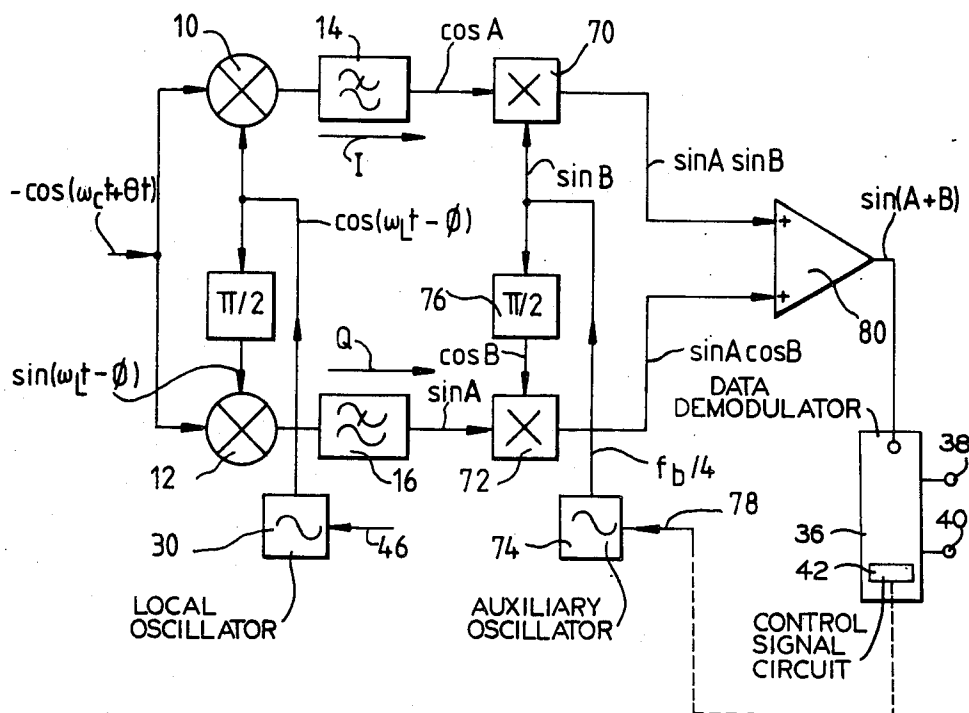

Fig. 3.



QUADRATURE DEMODULATION DATA RECEIVER WITH PHASE ERROR CORRECTION

This is a continuation of application Ser. No. 662,861, 5
filed Oct. 19, 1984, now abandoned.

BACKGROUND OF THE INVENTION

The present invention relates to a data receiver.
European Patent Specification Publication No. 0 098 10
649, to which U.S. Pat. No. 4,570,125 corresponds,
discloses a coherent data demodulator for digital signals
wherein correction signals for clock and carrier oscillators
are derived by comparing the times of the zero
crossings at the outputs of two orthogonal channels 15
with the nominal times at which these crossings should
occur. In the case of correcting the phase of the carrier
signals, a correction signal is fed back to the local oscillator
so that its frequency is adjusted in the desired
manner. Although the demodulator disclosed in EP 20
Specification No. 0 098 649 and corresponding U.S. Pat.
No. 4,570,125 operates satisfactorily, it does not have a
limitation which is concerned with the rate at which the
carrier phase can be adjusted. The carrier control loop
includes quadrature mixers and low pass filters which 25
have an inherent filter delay. If the carrier phase is
adjusted quickly compared to the filter delay then the
carrier control loop will go unstable. In some applica-
tions it is important for the receiver to have fast acquisition.
30

SUMMARY OF THE INVENTION

An object of the present invention is to obtain fast
acquisition in a coherent data demodulator.

According to the present invention there is provided 35
a data receiver including quadrature mixers having
outputs coupled by signal paths to a coherent data demodulator,
wherein correction of carrier phase errors is
effected after the outputs from the mixers have been
pass filtered.

In the data receiver made in accordance with the
present invention, the signal phase can be adjusted
downstream of the mixers and filters, with negligible
loop delay and hence without the risk of instability
which would occur if the phase of the local oscillator 40
was adjusted too quickly.

In an embodiment of the present invention, phase
shifting networks are provided in the signal paths to the
data demodulator which includes means for determining
the phase error in the carrier signal and producing a
control signal in response to the phase error deter- 45
mined, which control signal is used to determine a phase
correction to be applied by said phase shifting networks.

If desired, each phase shifting network has a plurality
of parallel outputs and means are provided for selecting
one of the outputs in response to the control signal and
thereby altering the phase of the signal being applied to
the data demodulator. An advantage of using phase
shifting networks having parallel outputs over networks 50
having serially arranged outputs is that the networks
can be designed to produce a substantially constant time
delay irrespective of the phase shift selected.

In another embodiment of the present invention in
which the data demodulator includes means for deter- 65
mining the phase error in the carrier signal and produc-
ing a control signal in response to the phase error deter-
mined, a sine/cosine generator is provided, the genera-

tor having an input coupled to receive the control signal
and first, second and third outputs on which are pro-
duced respectively the sine, cosine and minus sine of the
phase correction angle. First and second multipliers are
coupled to the output of the first mixer and third and
fourth multipliers are coupled to the output of the second
mixer. The first generator output is coupled to the
second multiplier, the second generator output is cou-
pled to the first and fourth multipliers and the third
generator output is coupled to the third multiplier. Ad-
ditionally first and second summing means are pro-
vided. Inputs of the first summing means are coupled
respectively to the outputs of the first and third multi-
pliers and inputs of the second summing means are
coupled respectively to the inputs of the second and
fourth multipliers. The outputs of the first and second
summing means are coupled to the data demodulator.

In a further embodiment of the present invention in
which the data demodulator includes means for deter-
mining the phase error in the carrier signal and produc-
ing a control signal in response to the phase error deter-
mined, a controllable frequency generator having an
output frequency corresponding to substantially one
quarter of the received bit rate is provided and has an
input for receiving the control signal. First and second
quadrature multipliers are provided, the first multiplier
being coupled to the output of the first mixer and the
second multiplier being coupled to the output of the
second mixer, an output of the controllable frequency
generator being coupled to the first and second multipli-
ers. Summing means are provided, the summing means
having first and second inputs coupled respectively to
outputs of the first and second multipliers.

By feeding a frequency of one quarter of the bit rate
into the multipliers, the phase of the summed output is
rotated by 90° every bit period. Consequently one has a
built-in demultiplexer.

BRIEF DESCRIPTION OF THE DRAWINGS

The present invention will now be described, by way
of example, with reference to the accompanying draw-
ings, wherein

FIG. 1 is a block schematic circuit of an embodiment
of a data receiver made in accordance with the present
invention,

FIG. 2 is a block schematic circuit diagram of an-
other embodiment of a data receiver made in accor-
dance with the present invention, and

FIG. 3 is a block schematic circuit diagram of a fur-
ther embodiment of a data receiver made in accordance
with the present invention.

DETAILED DESCRIPTION OF THE PREFERRED EMBODIMENTS

Referring to FIG. 1, a signal, which may be a fre-
quency modulated, differentially encoded input signal
 $f_c \pm \Delta f$, is applied to quadrature mixers 10, 12 to which
a frequency f_L , substantially equal to carrier frequency
 f_c , is applied from a local oscillator 30. The outputs of
the mixers 10, 12 are filtered in low pass filters 14, 16
which will pass the modulation frequency Δf . In an
alternative arrangement, not shown, the low pass filters
14, 16 may be omitted and the low pass filtering is done
in the mixers 10, 12. Thus in the in-phase channel I the
signal is $+\Delta f$ or $-\Delta f$ and in the quadrature channel Q
the signal is $+\Delta f - \pi/2$ or $-\Delta f - \pi/2$. By the way of
example, f_c may be 900 MHz and the deviation fre-

quency Δf would be a quarter of the bit rate, e.g. for a bit rate of 16 Kb/s Δf is 4 kHz.

In order to control the phase of the signals in the I and Q channels, the outputs of the filters 14, 16 are applied to phase shifting networks 18, 20 which have a plurality of parallel outputs 22, 24. The selection of a particular output 22, 24 is determined in accordance with the phase error in the local oscillator 30 output. As indicated, output selecting devices 26, 28 are ganged together so that the same phase shift is applied to both the I and Q channels. The signals on the devices 26, 28 are hard limited in limiting amplifiers 32, 34 and thereafter the signals are applied to a data demodulator 36 which includes means 44 for recovering the data and the clock signals which are provided on outputs 38, 40 and means 42 for providing a carrier control signal which is applied to the output selecting devices 26, 28.

In the method described for fast acquisitions, it is necessary that the phase of the quadrature signals fed to the limiting amplifiers 32, 34 be pulled quickly into phase lock; otherwise data will be lost.

In the circuit in accordance with the present invention, the phase of the carrier and clock signals is determined from the information contained in the times of the zero crossings at the hard limited outputs of the amplifiers 32, 24. Demodulator arrangements for doing this are described in EP Patent Specification No. 0 098 649, and corresponding U.S. Pat. No. 4,570,125 details of which arrangements are incorporated by way of reference. A description of these arrangements will, in the interests of brevity, not be given herein as they are not relevant to the understanding of the present invention.

In the demodulator arrangements disclosed in EP Patent Specification No. 0 098 649, and corresponding U.S. Pat. No. 4,570,125 the carrier phase correction signal is fed back to the local oscillator to correct its output. In consequence, as low pass filters are part of the correction loop, they impose a time limit on the rate at which the phase can be corrected, which time limit is undesirable if the data receiver is used to recover short burst data.

In the embodiment shown in FIG. 1, by arranging phase shifting networks 18, 20 downstream of the low pass filters 14, 16, the rate of phase correction is not limited by filters 14, 16.

In implementing the phase shifting networks 18, 20, it is preferred that the outputs 22, 24 be arranged in parallel because the time delay of the networks 18, 20 can be substantially constant irrespective of the applied phase shift. The phase shifting networks may be of any suitable type, for example transformers and networks of the Dome type. Although each network has been illustrated as comprising 6 outputs 22, 24, in reality there might be say 8 to 16 equally spaced outputs to provide 45° or $22\frac{1}{2}^\circ$ of phase shift within an overall range of 360° . The output selecting devices 26, 28 comprise switches which are operated in response to the carrier control signal from the means 42 in the data demodulator 36, to select the appropriate phase output.

In a non-illustrated alternative embodiment, the phase shifting networks 18, 20 may be of a series type; but a disadvantage of such an arrangement is that the time delay will vary in accordance with the amount of delay required.

It is not essential for automatic frequency control (AFC) to be applied to the local oscillator 30. However if it is found that the frequency stability of the local

oscillator 30 is not good enough, then a slow AFC can be applied via an input 46 from an output of the data demodulator 36.

FIG. 2 illustrates another embodiment of the invention in which the phase of the signal is corrected downstream of the low pass filters 14, 16. In the interests of brevity only the features of difference between FIGS. 1 and 2 will be described. The output from means 42 providing the carrier control signal is coupled to a sine/cosine generator 50 which produces sine, cosine and minus sine of the desired phase angle ϕ for correcting the error in the carrier signal on outputs 52, 54, 56.

Multipliers 58, 60 are coupled to the output of the low pass filter 14 on which the signal $\cos A$ is present, and multipliers 62, 64 are coupled to the output of the low pass filter 16 on which the signal $\sin A$ is present. The outputs of the multipliers 58, 62 are coupled to a summing circuit 66 whose output is coupled to the limiting amplifier 32. Similarly, the outputs of the multipliers 60, 64 are coupled to the summing circuit 68 whose output is coupled to the limiting amplifier 34. The output 52 of the sine/cosine generator 50 is connected to the multiplier 60, the output 54 is applied to the multipliers 58, 64 and the output 56 is applied to the multiplier 62. Thus the inputs to the summing circuit 66 are:

$\cos A \cos \phi$ and $-\sin A \sin \phi$ which combine to form the output $\cos(A + \phi)$; the inputs to the summing circuit 68 are:

$\cos A \sin \phi$ and $\sin A \cos \phi$ which combine to form the output $\sin(A + \phi)$.

These signals are then demodulated in the data demodulator 36.

In implementing the circuit shown in FIG. 2 the sine/cosine generator 50 can be either an analogue function generator or, particularly if a digital output is produced by the means 42, a digital function generator formed by a register, a ROM and digital-to-analogue converters.

FIG. 3 illustrates a further embodiment of the present invention wherein the carrier phase is adjusted downstream of the low pass filters 14, 16. The outputs from these filters comprise $\cos A$ and $\sin A$, respectively, where $A = (\omega_C - \omega_L)t + \phi + \theta t$ and θt is the modulation. These outputs are applied to multipliers 70, 72 to which the output of an auxiliary oscillator 74 is connected; in the case of the multiplier 72, the auxiliary oscillator output is shifted in phase by $\pi/2$ in a phase shifter 76. The frequency of the auxiliary oscillator 74 is nominally $f_b/4$ which corresponds to a quarter of the bit frequency f_b . However, the frequency and phase of this signal is adjusted in response to a carrier control signal applied to the auxiliary oscillator on an input 78. In FIG. 3 the auxiliary oscillator output is referred to as $\sin B$ and the quadrature phase shifted output is referred to as $\cos B$ where

$$B = \omega_b t / 4 - (\omega_C - \omega_L) t - \phi$$

The outputs $\cos A \sin B$ and $\sin A \cos B$ from the multipliers 70, 72 are combined in a summing amplifier 80 to produce an output $\sin(A + B)$ which equals $\sin[\omega_b t / 4 + \theta t]$.

Thus by feeding a frequency of one quarter the bit rate ($f_b/4$) into the multipliers, the phase of the summed output from the amplifier 80 is rotated by 90° every bit period in addition to the modulation θt . In the data demodulator the data is recovered by alternately strobing the two quadrature signals. This is equivalent to

Explore Litigation Insights

Docket Alarm provides insights to develop a more informed litigation strategy and the peace of mind of knowing you're on top of things.

Real-Time Litigation Alerts



Keep your litigation team up-to-date with **real-time alerts** and advanced team management tools built for the enterprise, all while greatly reducing PACER spend.

Our comprehensive service means we can handle Federal, State, and Administrative courts across the country.

Advanced Docket Research



With over 230 million records, Docket Alarm's cloud-native docket research platform finds what other services can't. Coverage includes Federal, State, plus PTAB, TTAB, ITC and NLRB decisions, all in one place.

Identify arguments that have been successful in the past with full text, pinpoint searching. Link to case law cited within any court document via Fastcase.

Analytics At Your Fingertips



Learn what happened the last time a particular judge, opposing counsel or company faced cases similar to yours.

Advanced out-of-the-box PTAB and TTAB analytics are always at your fingertips.

API

Docket Alarm offers a powerful API (application programming interface) to developers that want to integrate case filings into their apps.

LAW FIRMS

Build custom dashboards for your attorneys and clients with live data direct from the court.

Automate many repetitive legal tasks like conflict checks, document management, and marketing.

FINANCIAL INSTITUTIONS

Litigation and bankruptcy checks for companies and debtors.

E-DISCOVERY AND LEGAL VENDORS

Sync your system to PACER to automate legal marketing.