



US 20090309243A1

(19) **United States**

(12) **Patent Application Publication**
Carmack et al.

(10) **Pub. No.: US 2009/0309243 A1**

(43) **Pub. Date: Dec. 17, 2009**

(54) **MULTI-CORE INTEGRATED CIRCUITS
HAVING ASYMMETRIC PERFORMANCE
BETWEEN CORES**

Publication Classification

(51) **Int. Cl.**
H01L 23/58 (2006.01)
(52) **U.S. Cl.** **257/798**

(75) **Inventors:** **Phil Carmack**, Santa Clara, CA
(US); **Brian Smith**, Mountain View,
CA (US)

(57) **ABSTRACT**

An integrated circuit in one embodiment includes asymmetric cores and an asymmetric core control circuit. At least one of the asymmetric cores is a different implementation of substantially the same function or subset of functionality as another core. The asymmetric core control circuit determines a performance parameter of an integrated circuit. The performance parameter may be the workload, the operating frequency, power consumption, quality of service, operating temperature or the like of the integrated circuit or a given portion of the integrated circuit. If the performance parameter is within a first range, the asymmetric core control circuit utilizes a first core to perform a function of the integrated circuit and idles a second core that is a different implementation of substantially the same function. If the performance parameter is within a second range, the core control circuit utilizes the second core to perform the function and idles the first core.

Correspondence Address:
NVIDIA C/O MURABITO, HAO & BARNES LLP
TWO NORTH MARKET STREET, THIRD
FLOOR
SAN JOSE, CA 95113 (US)

(73) **Assignee:** **NVIDIA CORPORATION**, Santa
Clara, CA (US)

(21) **Appl. No.:** **12/137,053**

(22) **Filed:** **Jun. 11, 2008**

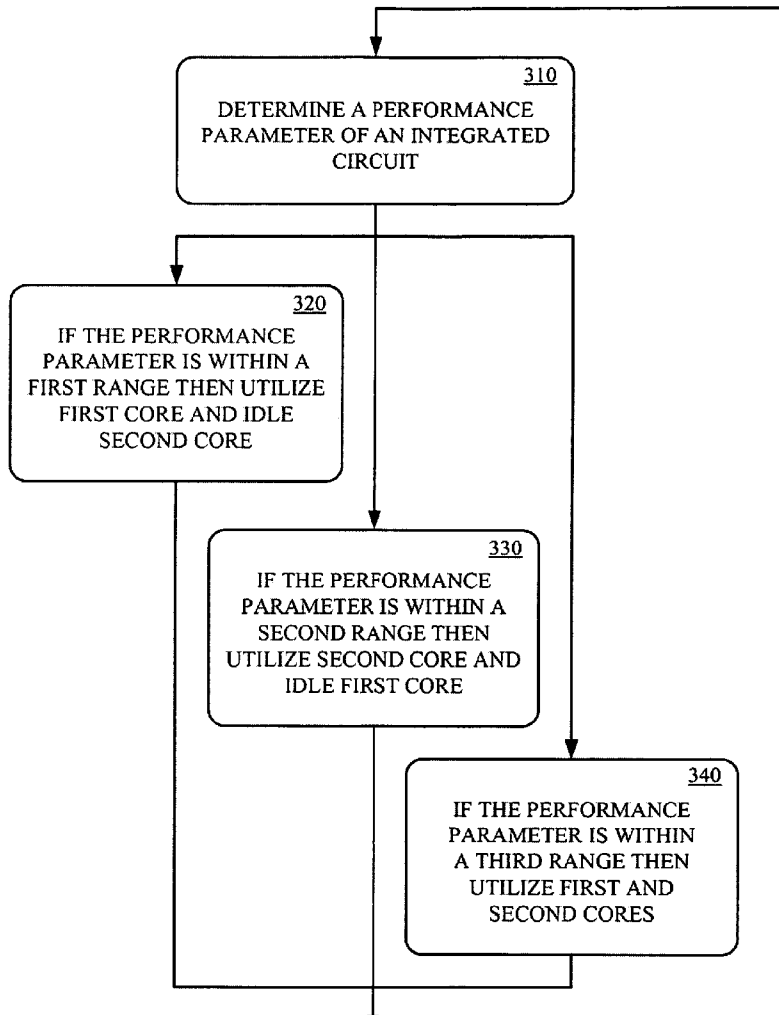

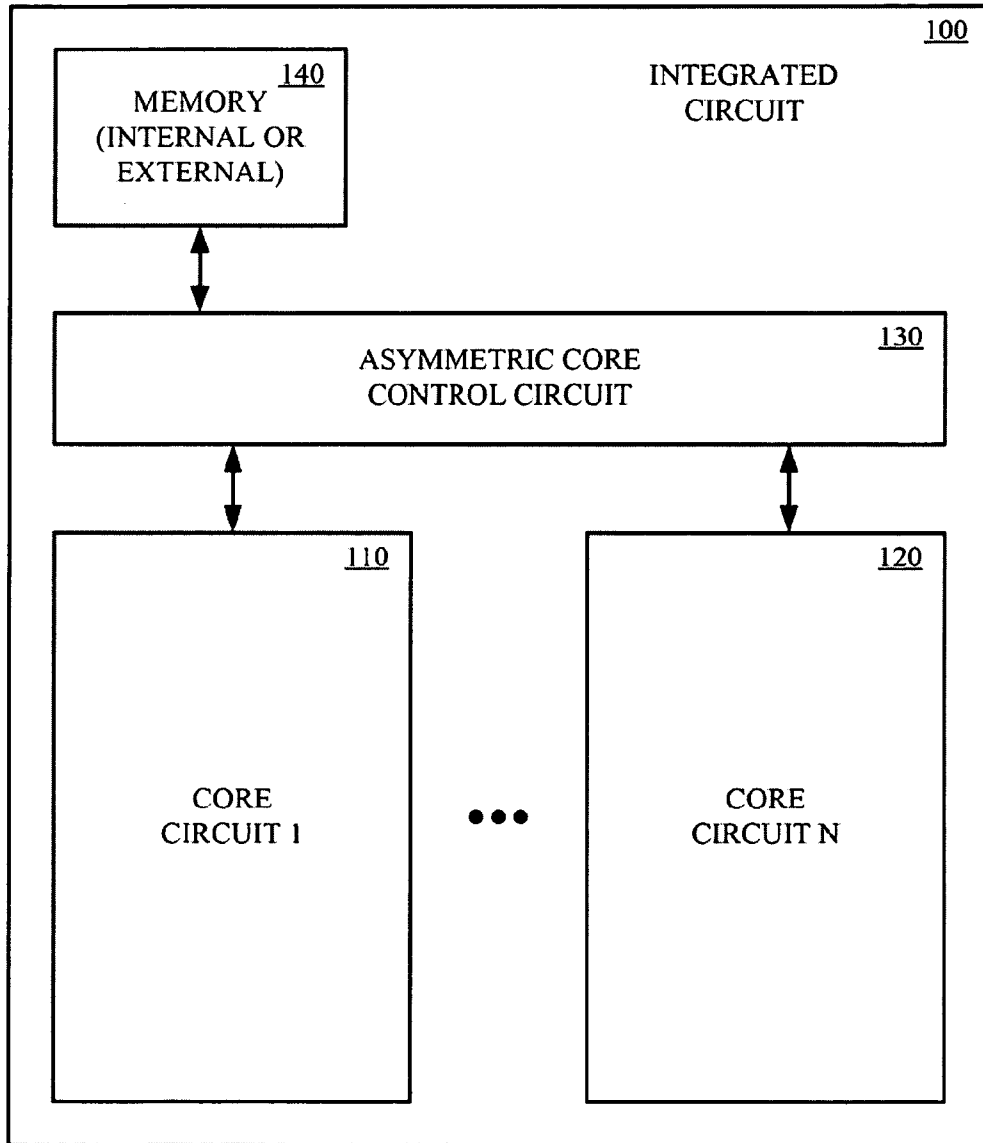

Figure 1

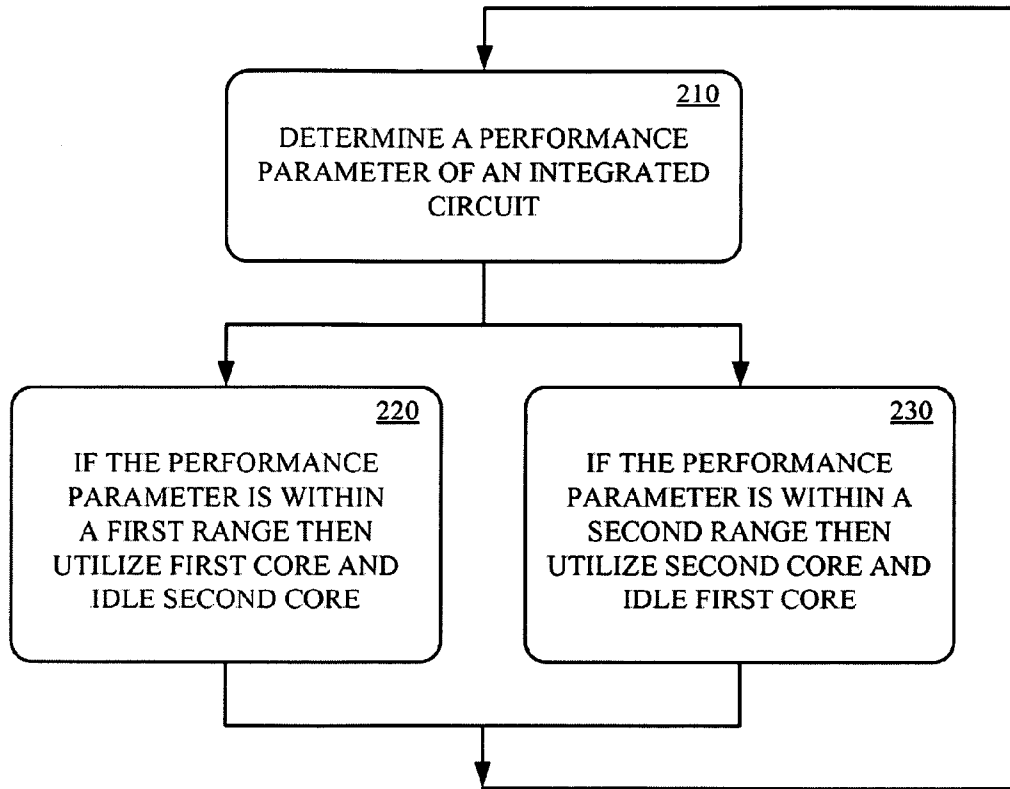

Figure 2

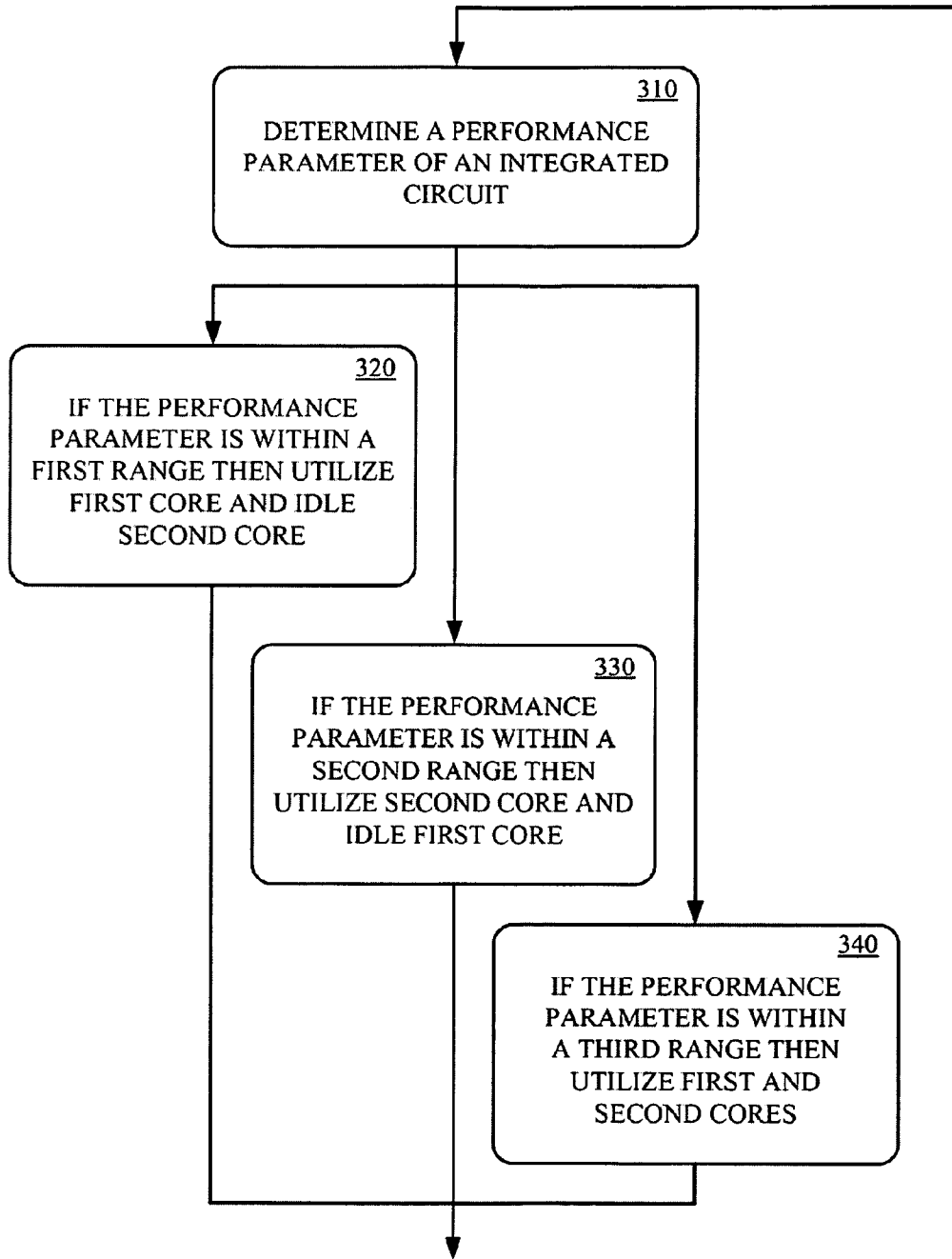

Figure 3

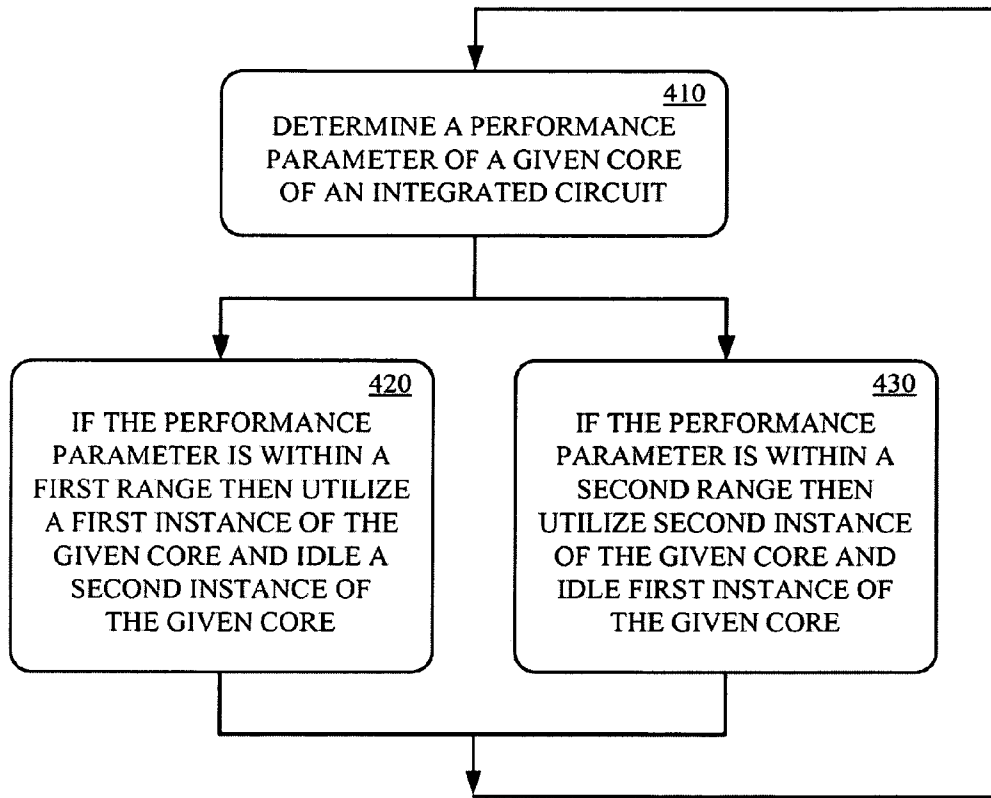

Figure 4

Explore Litigation Insights

Docket Alarm provides insights to develop a more informed litigation strategy and the peace of mind of knowing you're on top of things.

Real-Time Litigation Alerts



Keep your litigation team up-to-date with **real-time alerts** and advanced team management tools built for the enterprise, all while greatly reducing PACER spend.

Our comprehensive service means we can handle Federal, State, and Administrative courts across the country.

Advanced Docket Research



With over 230 million records, Docket Alarm's cloud-native docket research platform finds what other services can't. Coverage includes Federal, State, plus PTAB, TTAB, ITC and NLRB decisions, all in one place.

Identify arguments that have been successful in the past with full text, pinpoint searching. Link to case law cited within any court document via Fastcase.

Analytics At Your Fingertips



Learn what happened the last time a particular judge, opposing counsel or company faced cases similar to yours.

Advanced out-of-the-box PTAB and TTAB analytics are always at your fingertips.

API

Docket Alarm offers a powerful API (application programming interface) to developers that want to integrate case filings into their apps.

LAW FIRMS

Build custom dashboards for your attorneys and clients with live data direct from the court.

Automate many repetitive legal tasks like conflict checks, document management, and marketing.

FINANCIAL INSTITUTIONS

Litigation and bankruptcy checks for companies and debtors.

E-DISCOVERY AND LEGAL VENDORS

Sync your system to PACER to automate legal marketing.