



US005922076A

United States Patent [19]

[11] Patent Number: **5,922,076**

Garde

[45] Date of Patent: **Jul. 13, 1999**

[54] CLOCKING SCHEME FOR DIGITAL SIGNAL PROCESSOR SYSTEM

Attorney, Agent, or Firm—Wolf, Greenfield & Sacks, P.C.

[75] Inventor: **Douglas Garde**, Dover, Mass.

[57] ABSTRACT

[73] Assignee: **Analog Devices, Inc.**, Norwood, Mass.

A digital signal processing system includes a cluster of processors and a host. A host can access each of the processors through an external bus system that interconnects the host with each of the processors. An external port of each of the processors operates at one of a local clock frequency and a host clock frequency, the local clock frequency and host clock frequency being asynchronous with one another. The host operates at the host clock frequency. Upon a host access of one of the processors, the clock frequency of operation of the external parallel port of each processor automatically is controlled to operate at the host clock frequency. In an embodiment, each processor also includes a core processor that operates at a core clock frequency that is a multiple of the local clock frequency, asynchronous with the host clock frequency. Thus, the speed of operation of the core processor and that of the external parallel port can be optimized independently.

[21] Appl. No.: **08/931,665**

[22] Filed: **Sep. 16, 1997**

[51] Int. Cl.⁶ **G06F 1/04**

[52] U.S. Cl. **713/600**

[58] Field of Search 395/553, 555, 395/556, 559; 713/500, 501, 600; 709/400, 248

[56] References Cited

U.S. PATENT DOCUMENTS

5,611,075	3/1997	Garde	395/480
5,619,720	4/1997	Garde et al.	395/800
5,685,005	11/1997	Garde et al.	395/800

Primary Examiner—Thomas M. Heckler

12 Claims, 6 Drawing Sheets

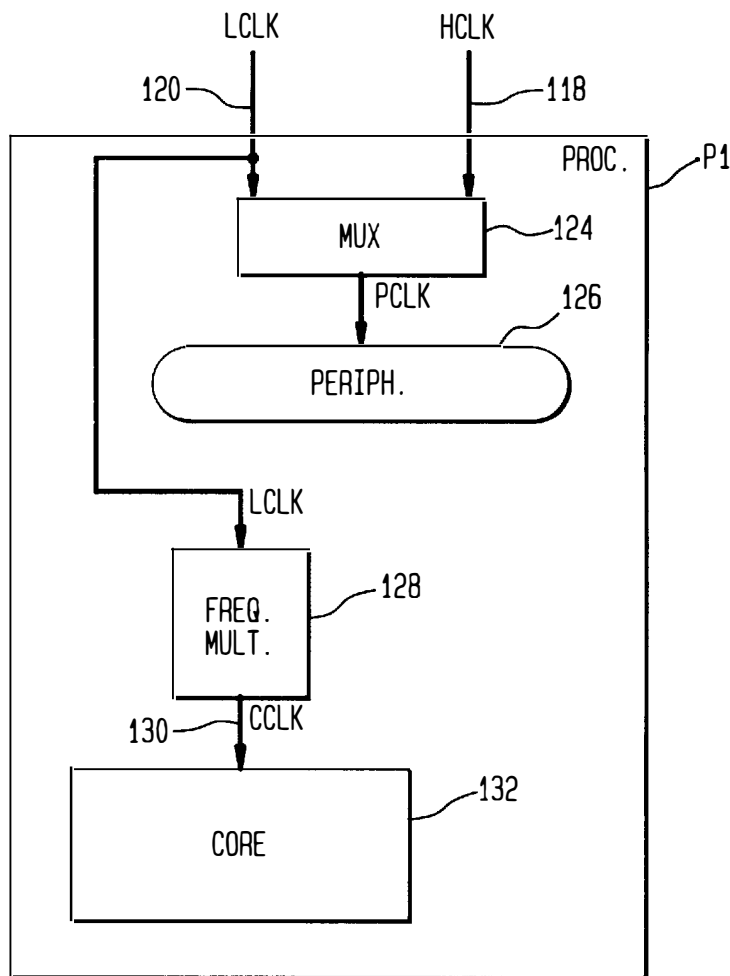

FIG. 1

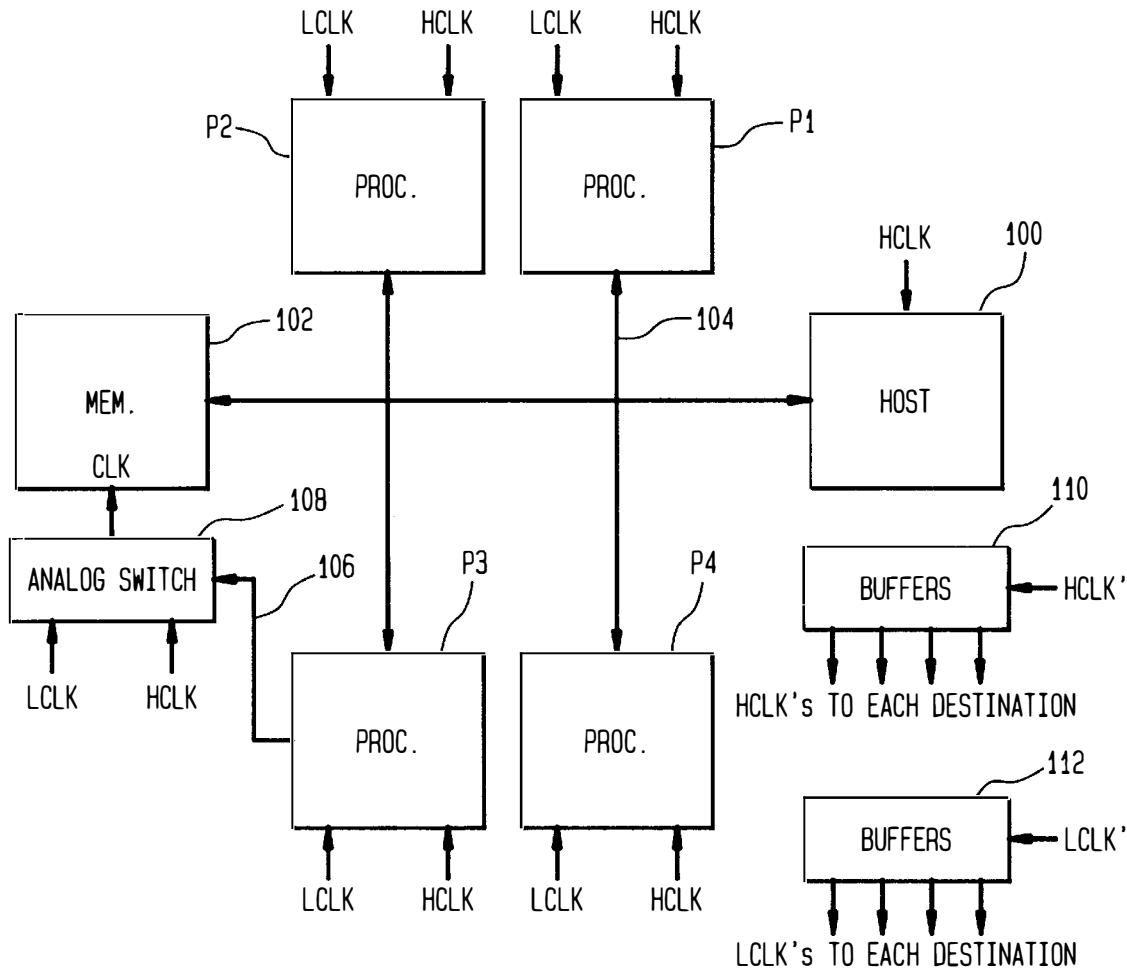

FIG. 2

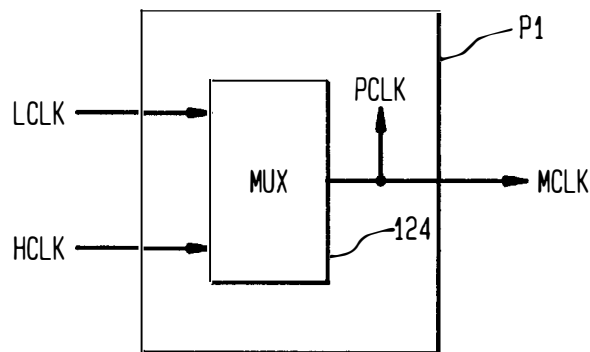

FIG. 3

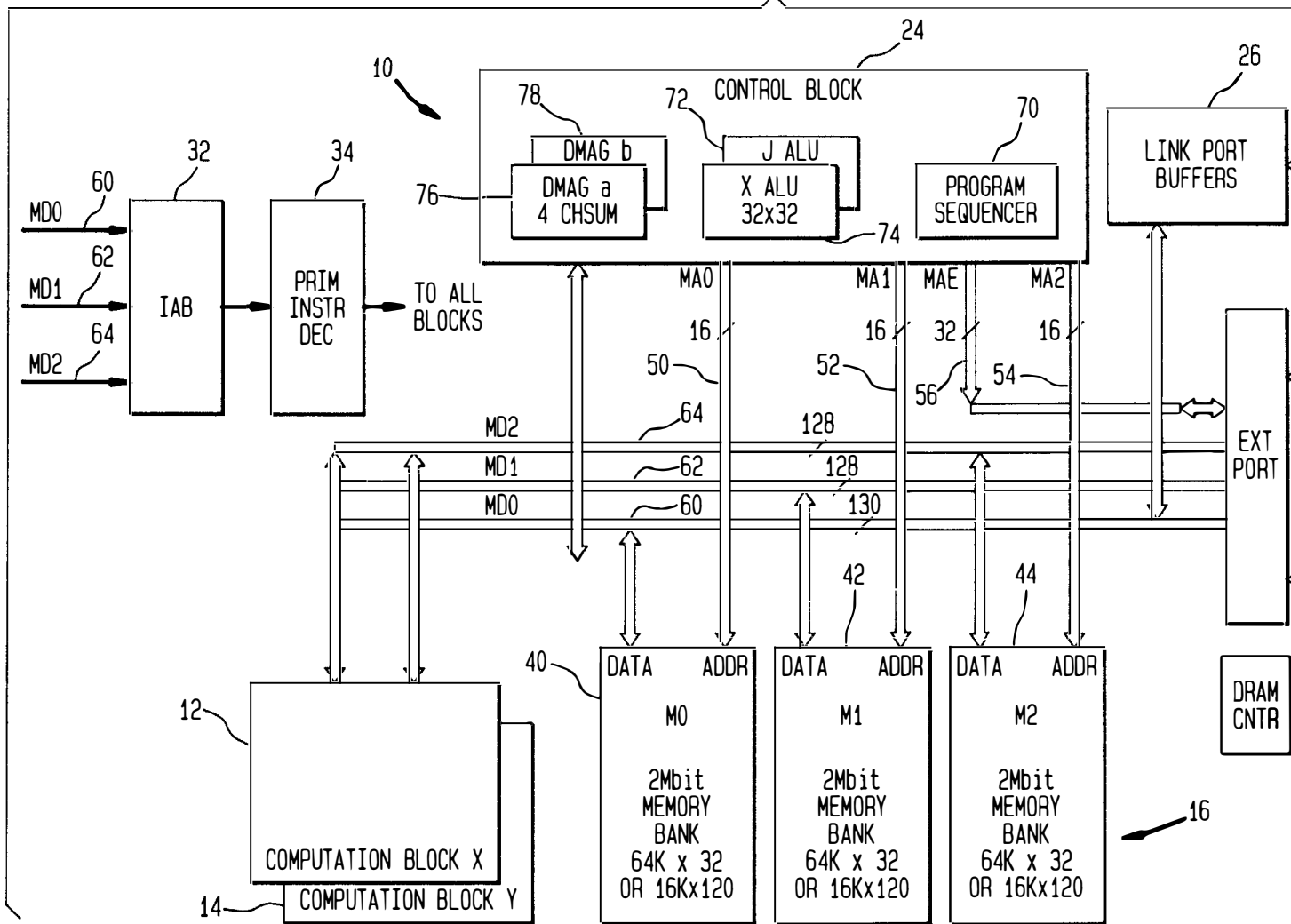
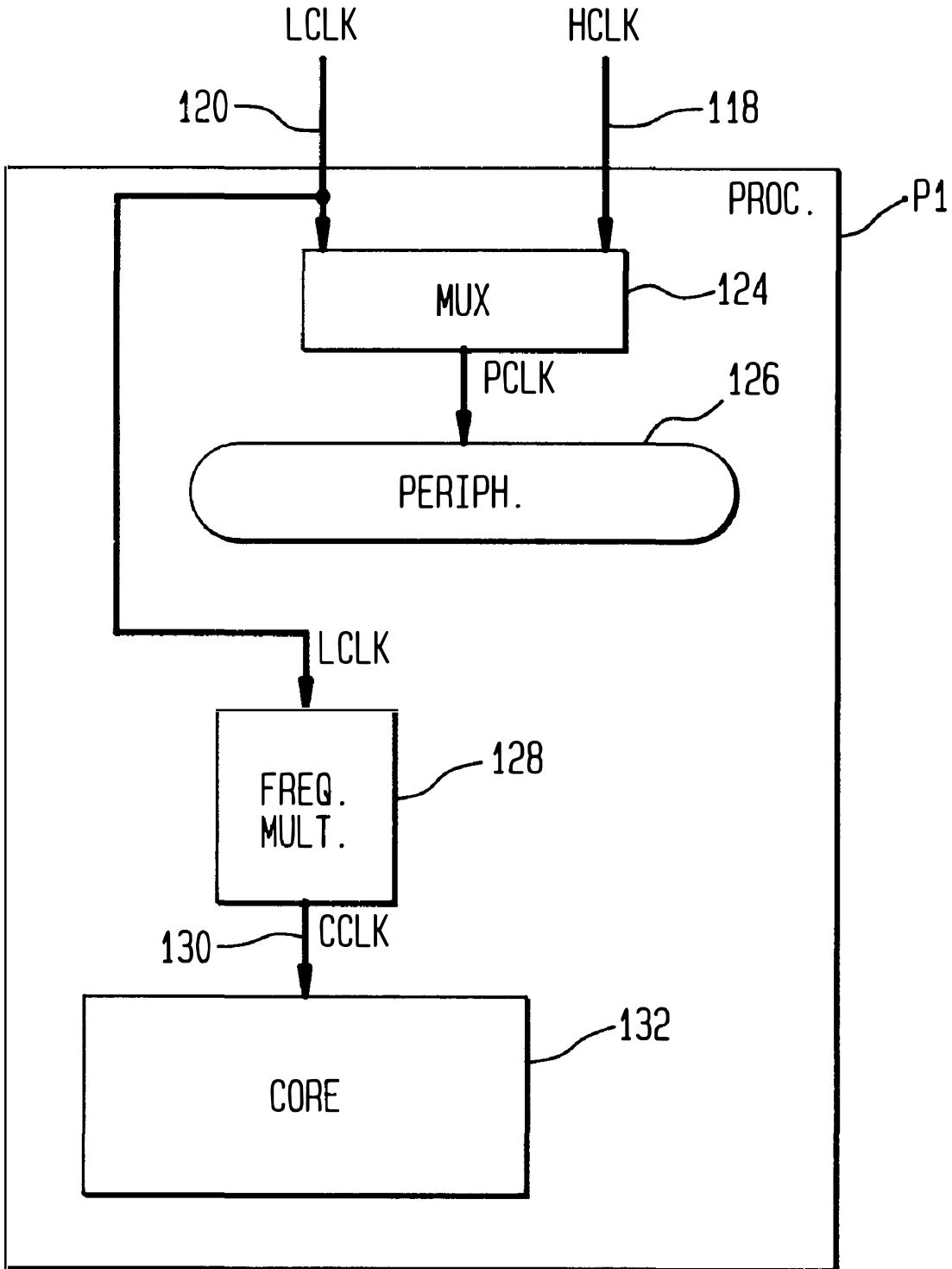

FIG. 4



Explore Litigation Insights

Docket Alarm provides insights to develop a more informed litigation strategy and the peace of mind of knowing you're on top of things.

Real-Time Litigation Alerts



Keep your litigation team up-to-date with **real-time alerts** and advanced team management tools built for the enterprise, all while greatly reducing PACER spend.

Our comprehensive service means we can handle Federal, State, and Administrative courts across the country.

Advanced Docket Research



With over 230 million records, Docket Alarm's cloud-native docket research platform finds what other services can't. Coverage includes Federal, State, plus PTAB, TTAB, ITC and NLRB decisions, all in one place.

Identify arguments that have been successful in the past with full text, pinpoint searching. Link to case law cited within any court document via Fastcase.

Analytics At Your Fingertips



Learn what happened the last time a particular judge, opposing counsel or company faced cases similar to yours.

Advanced out-of-the-box PTAB and TTAB analytics are always at your fingertips.

API

Docket Alarm offers a powerful API (application programming interface) to developers that want to integrate case filings into their apps.

LAW FIRMS

Build custom dashboards for your attorneys and clients with live data direct from the court.

Automate many repetitive legal tasks like conflict checks, document management, and marketing.

FINANCIAL INSTITUTIONS

Litigation and bankruptcy checks for companies and debtors.

E-DISCOVERY AND LEGAL VENDORS

Sync your system to PACER to automate legal marketing.