

- [54] **NOISE REDUCTION SYSTEM FOR BINAURAL HEARING AID**
- [75] Inventors: **Eric Lindemann; John Laurence Melanson**, both of Boulder, Colo.
- [73] Assignee: **AudioLogic, Inc.**, Boulder, Colo.
- [21] Appl. No.: **123,503**
- [22] Filed: **Sep. 17, 1993**
- [51] **Int. Cl.<sup>6</sup>** ..... **H04R 25/00**
- [52] **U.S. Cl.** ..... **381/68.2; 381/68.4; 395/2.35**
- [58] **Field of Search** ..... 381/68.2, 68, 68.4, 381/60, 26, 74, 94, 46, 47; 395/2.35, 2.12, 2.37, 2.42

"Evaluation of Two Voice-Separation Algorithms Using Normal-Hearing and Hearing-Impaired Listeners" By R. Stubbs et al, J. Acoust. Soc., Oct. 1988.

"Improvement of Speech Intelligibility In Noise Development and Evaluation of a New Directional Hearing Instrument Based On Array Technology" By W. Soede, Delft Univ. of Technology.

Article Entitled "Evaluation of An Adaptive Beamforming Method for Hearing Aids" By J. Greenberg et al, J. Acoust. Soc. Am. 91 (3), Mar. 1992, pp. 1662-1676.

"Digital Signal Processing for Binaural Hearing Aids" By Kollmeier et al, Proceedings International Congress on Acoustics, 1992, Beijing, China.

Article Entitled "Cocktail-Party-Processing: Concept and Results" By M. Bodden, Bodden Proceedings, 1992, Beijing, China.

[56] **References Cited**

(List continued on next page.)

**U.S. PATENT DOCUMENTS**

4,628,529	12/1986	Borth et al. .	
4,630,305	12/1986	Borth et al. .	
4,868,880	9/1989	Bennett, Jr. .	
4,887,299	12/1989	Cummins et al. .	
5,029,217	7/1991	Chabies et al. .	
5,341,452	8/1994	Hall, II et al. ....	395/2.35

**OTHER PUBLICATIONS**

"Multimicrophone Signal-Processing Technique to Remove Reverberation from Speech Signals" by J. Allen et al, vol. 62, No. 4, Oct. 1977, pp. 912-915.

"An Alternative Approach to Linearly Constrained Adaptive Beamforming" By L. J. Griffiths et al, IEEE Transactions, vol. AP-30, No. 1, Jan. 1982, pp. 27-34.

"Speech Enhancement Using A Minimum Mean-Square Error Short-Time Spectral Amplitude Estimator" By Y. Ephraim et al, IEE Transactions, Dec. 1984, No. 6.

Article Entitled "Extension of a Binaural Cross-Correlation Model by Contralateral Inhibition" By W. Lindemann, J. Acoust. Soc. Am. 80(6), Dec. 1986, pp. 1608-1622.

"Multimicrophone Adaptive Beamforming for Interference Reduction In Hearing Aids" by P. Peterson et al, Journal of Rehabilitation Research and Development, vol. 24, No. 4, pp. 103-110.

*Primary Examiner*—Curtis Kuntz  
*Assistant Examiner*—Huyen D. Le  
*Attorney, Agent, or Firm*—Homer L. Knearl; Holland & Hart

[57] **ABSTRACT**

In this invention noise in a binaural hearing aid is reduced by analyzing the left and right digital audio signals to produce left and right signal frequency domain vectors and thereafter using digital signal encoding techniques to produce a noise reduction gain vector. The gain vector can then be multiplied against the left and right signal vectors to produce a noise reduced left and right signal vector. The cues used in the digital encoding techniques include directionality, short term amplitude deviation from long term average, and pitch. In addition, a multidimensional gain function based on directionality estimate and amplitude deviation estimate is used that is more effective in noise reduction than simply summing the noise reduction results of directionality alone and amplitude deviations alone. As further features of the invention, the noise reduction is scaled based on pitch-estimates and based on voice detection.

**14 Claims, 5 Drawing Sheets**

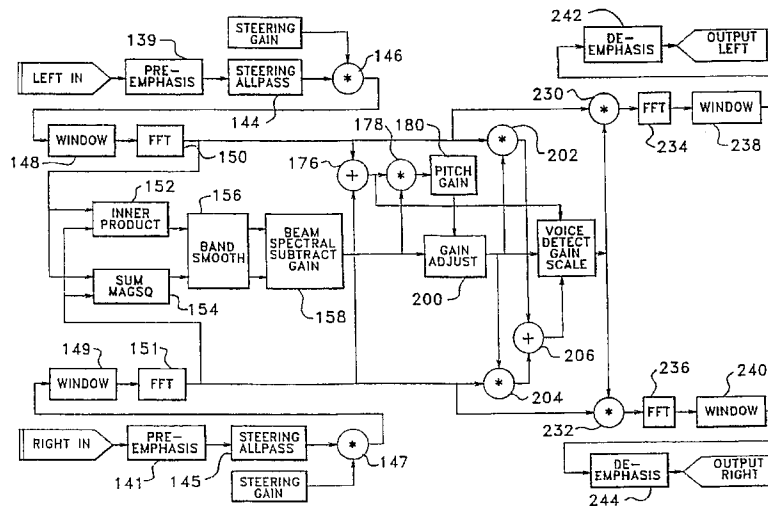

OTHER PUBLICATIONS

“Microphone Array Speech Enhancement In Overdetermined Signal Scenarios” By R. Slyh et al., Proceedings IEEE International Conference on Acoustics, Speech and Signal Processing, II-347-II-350.

“Separation of Speech from Interfering Speech By Means of Harmonic Selection” by T. Parsons, J. Acoust. Soc. Am., vol. 60, No. 4, Oct. 1976, pp. 911-918.

“Suppression of Acoustic Noise In Speech Using Spectral Subtraction” By S. Boll, IEEE Transactions on Acoustics, Speech and Signal Processing, vol. ASSP-27, No. 2, Apr. 1979, pp. 113-120.

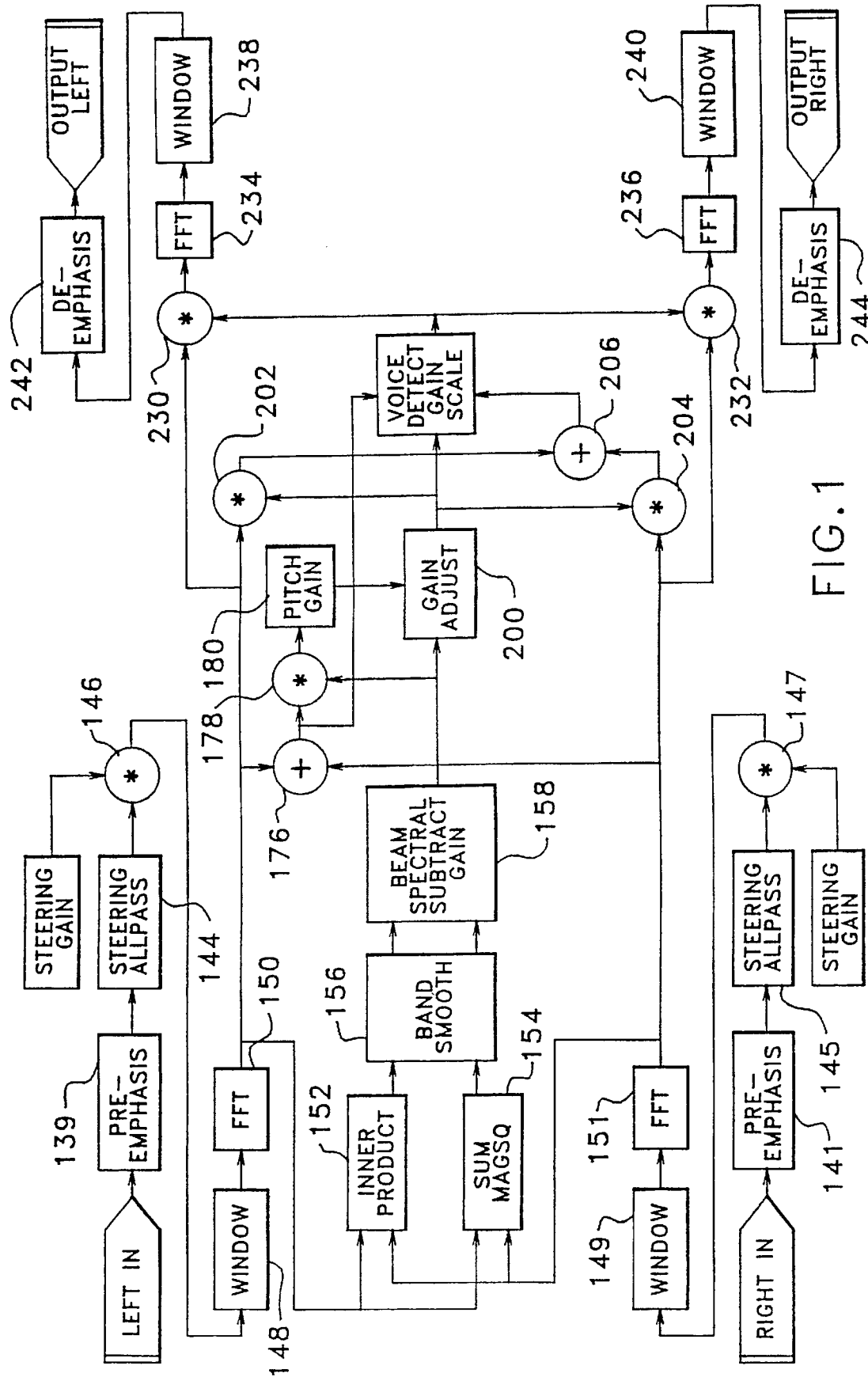

FIG. 1

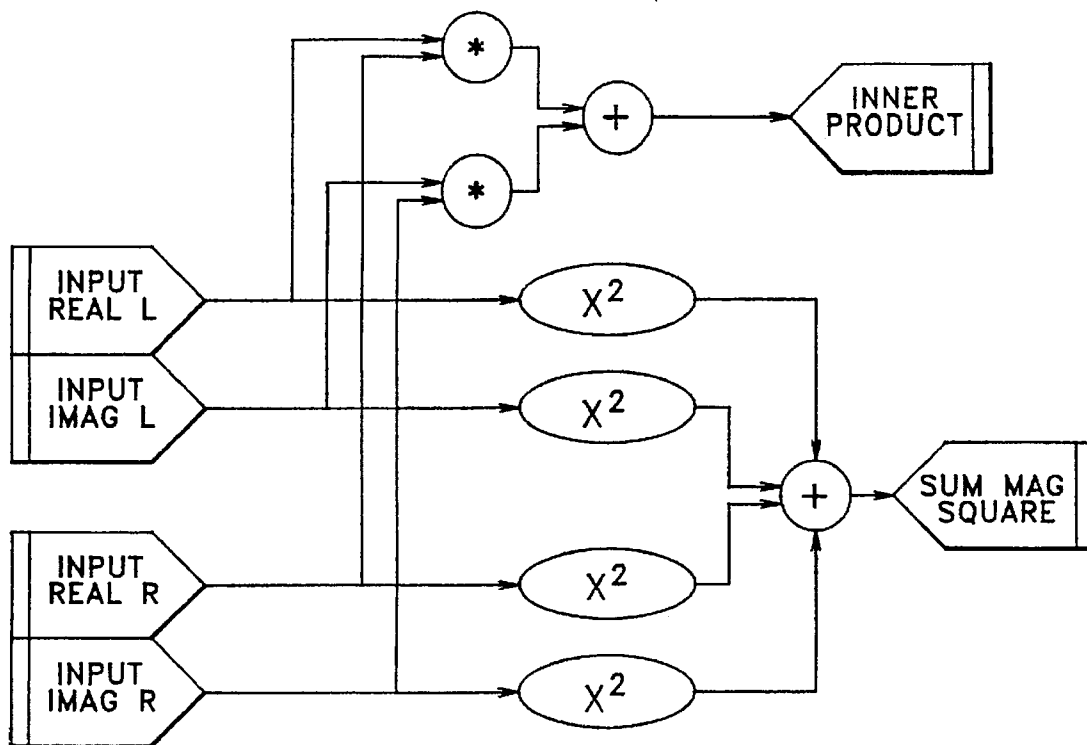

FIG.2

NOTE: THIS CIRCUIT IS REPEATED FOR EVERY FREQUENCY F OF THE FFT

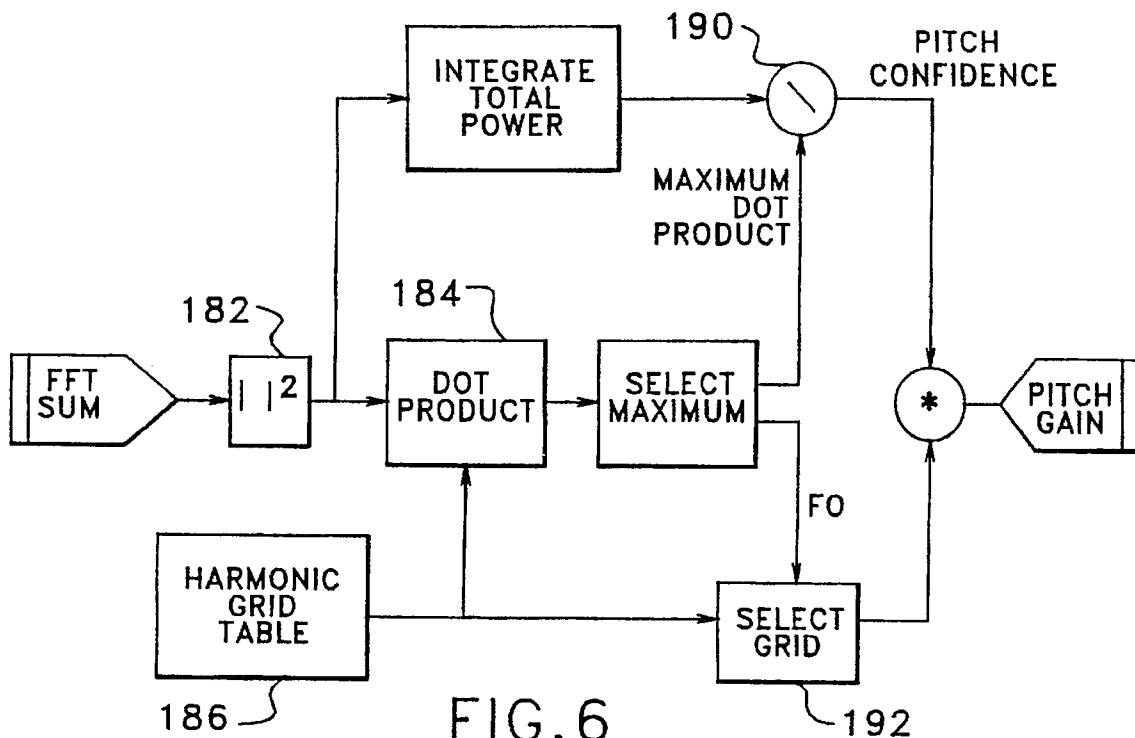
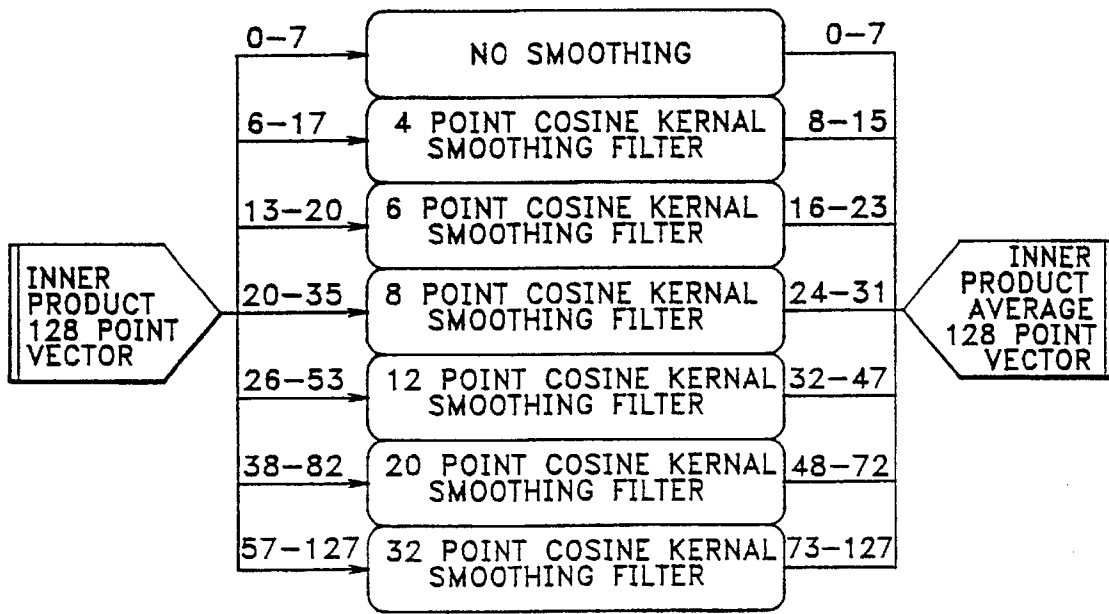
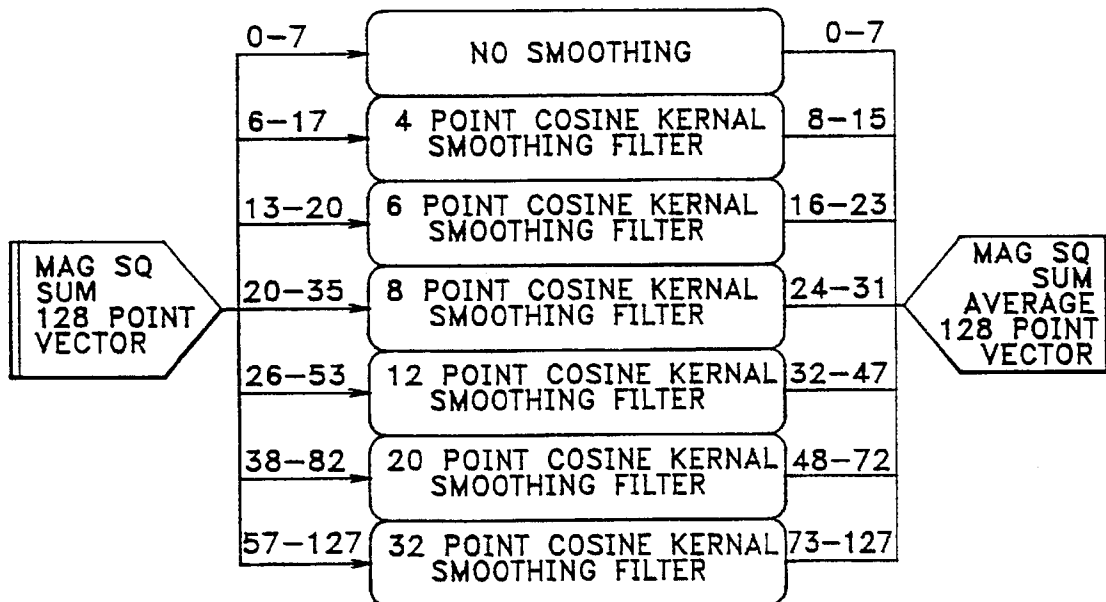

FIG.6



157  
FIG. 3A



157  
FIG. 3B

# Explore Litigation Insights

Docket Alarm provides insights to develop a more informed litigation strategy and the peace of mind of knowing you're on top of things.

## Real-Time Litigation Alerts



Keep your litigation team up-to-date with **real-time alerts** and advanced team management tools built for the enterprise, all while greatly reducing PACER spend.

Our comprehensive service means we can handle Federal, State, and Administrative courts across the country.

## Advanced Docket Research



With over 230 million records, Docket Alarm's cloud-native docket research platform finds what other services can't. Coverage includes Federal, State, plus PTAB, TTAB, ITC and NLRB decisions, all in one place.

Identify arguments that have been successful in the past with full text, pinpoint searching. Link to case law cited within any court document via Fastcase.

## Analytics At Your Fingertips



Learn what happened the last time a particular judge, opposing counsel or company faced cases similar to yours.

Advanced out-of-the-box PTAB and TTAB analytics are always at your fingertips.

## API

Docket Alarm offers a powerful API (application programming interface) to developers that want to integrate case filings into their apps.

## LAW FIRMS

Build custom dashboards for your attorneys and clients with live data direct from the court.

Automate many repetitive legal tasks like conflict checks, document management, and marketing.

## FINANCIAL INSTITUTIONS

Litigation and bankruptcy checks for companies and debtors.

## E-DISCOVERY AND LEGAL VENDORS

Sync your system to PACER to automate legal marketing.