

UNITED STATES PATENT AND TRADEMARK OFFICE

BEFORE THE PATENT TRIAL AND APPEAL BOARD

SONY ELECTRONICS INC.,
Petitioner,

v.

JAWBONE INNOVATIONS, LLC,
Patent Owner.

IPR2023-01153
Patent 11,122,357 B2

Before GEORGIANNA W. BRADEN, NORMAN H. BEAMER,
and JASON M. REPKO, *Administrative Patent Judges*.

BEAMER, *Administrative Patent Judge*.

DECISION
Denying Institution of *Inter Partes* Review
35 U.S.C. § 314
Denying Motion For Joinder
37 C.F.R. § 42.122

I. INTRODUCTION

On June 30, 2023, Meta Platforms, Inc. (“Petitioner”) filed a Petition (“Pet.”) pursuant to 35 U.S.C. §§ 311–319 to institute an *inter partes* review of claims 1–20 of U.S. Patent No. 11,122,357 B2 (Ex. 1001, “the ’357 patent”). Paper 1. On October 16, 2023, Jawbone Innovations, LLC (“Patent Owner”) filed a Preliminary Response (“Prelim. Resp.”). Paper 8.

On June 30, 2023, Petitioner also filed a Motion for Joinder to And Consolidation With Related *Inter Partes* Review IPR2023-00251, which Patent Owner opposed on July 31, 2023. Papers 3, 7. However, on August 8, 2023, that Proceeding was terminated due to settlement. IPR2023-00251, Paper 15. Accordingly, Petitioner’s motion for joinder is denied as moot.

The standard for instituting an *inter partes* review is set forth in 35 U.S.C. § 314(a), which provides that an *inter partes* review may not be instituted unless the information presented in the Petition and any preliminary response shows that “there is a reasonable likelihood that the petitioner would prevail with respect to at least 1 of the claims challenged in the petition.” Applying that standard, we deny the Petition and do not institute an *inter partes* review.

II. BACKGROUND

A. *The ’357 Patent*

The ’357 patent, titled “Forming Virtual Microphone Arrays Using Dual Omnidirectional Microphone Array (DOMA),” was filed on August 5, 2013, issued on September 14, 2021, is a continuation of an application filed June 13, 2008, and lists several provisional applications, the earliest of which was filed on June 13, 2007. Ex. 1001, codes (54), (22), (45), (63), (60); Pet. 21.

The '357 patent is directed to:

[a] dual omnidirectional microphone array noise suppression [system] used to form two distinct virtual directional microphones which are configured to have very similar noise responses and very dissimilar speech responses. The only null formed is one used to remove the speech of the user from [the second virtual microphone]. The two virtual microphones may be paired with an adaptive filter algorithm and VAD [Voice Activity Detector] algorithm to significantly reduce the noise without distorting the speech, significantly improving the SNR [signal-to-noise ratio] of the desired speech over conventional noise suppression systems.

Ex. 1001, code (57). Figure 1 is reproduced below.

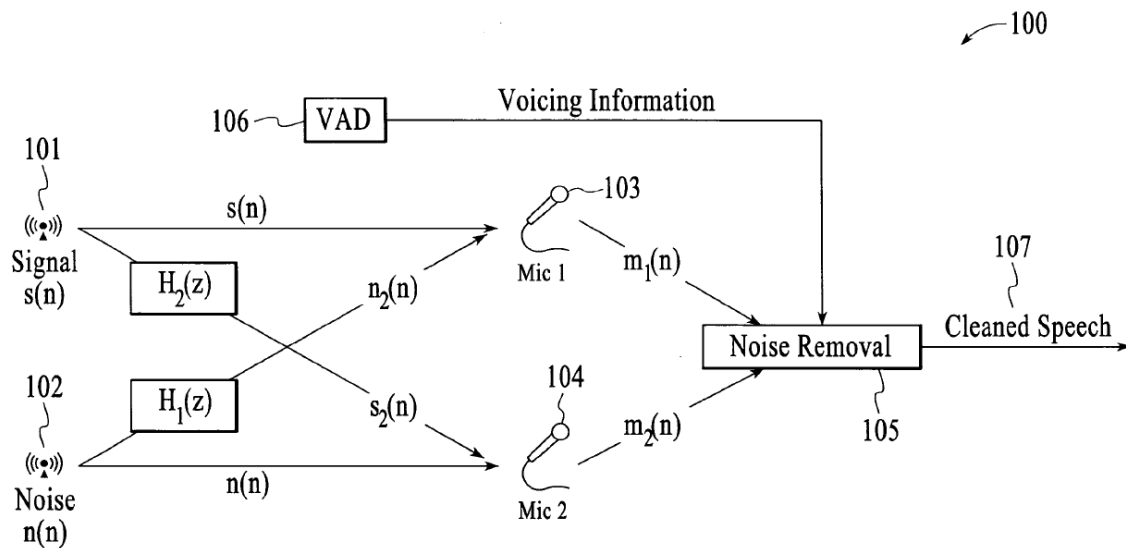

Figure 1 is a block diagram of a two-microphone adaptive noise suppression system. Ex. 1001, 2:29–30. Microphones Mic 1 and Mic 2 receive acoustic information from speech signal source 101 and noise source 102, and the acoustic information received at each microphone is provided to Noise Removal system 105. *Id.* at 6:11–25. VAD 106 is a voice activity detector which generates a voicing information signal indicating when user speech is detected—for example, a skin surface microphone. *Id.* at 5:64–67, 6:5–6.

Noise Removal component 105 generates the virtual microphones paired with the adaptive filter algorithm to generate cleaned speech 107. *Id.* at 5:16–21.

The DOMA provides adaptive noise cancellation by filtering and summing the two microphone signals in the time domain. Ex. 1001, 8:27–30. The adaptive filter generally uses the signal received from a microphone of the DOMA to remove noise from the speech received from the other microphone of the DOMA, relying on a slowly varying linear transfer function between the two microphones for sources of noise. *Id.* at 8:30–35. Following processing of the two channels of the DOMA, an output signal is generated in which the noise content is attenuated with respect to the speech content. *Id.* at 8:35–38. According to the '357 patent, the disclosed embodiments “result[] in excellent noise suppression performance and minimal speech removal and distortion.” *Id.* at 8:16–18.

In one embodiment, virtual directional microphones are formed from the physical microphones as shown in Figure 4 reproduced below:

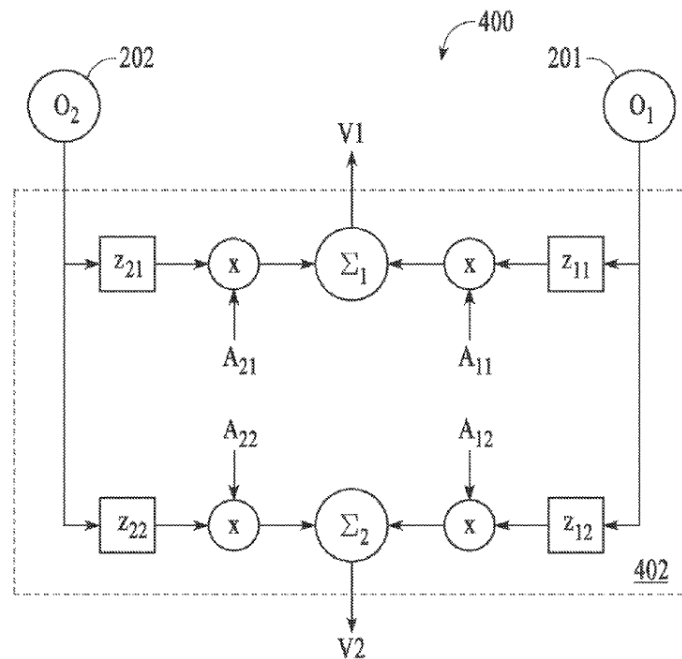

FIG.4

Figure 4 is a block diagram for a DOMA depicting how two virtual directional microphones V_1 and V_2 are formed based on two physical omnidirectional microphones O_1 and O_2 , where the physical microphone signals are coupled to processing component 402, in which delays z_{21} , z_{11} , z_{22} , and z_{12} , and gains A_{21} , A_{11} , A_{22} , and A_{12} are applied to the signals, which are then summed via Σ_1 and Σ_2 . Ex. 1001, 2:40–42, 8:62–9:21. As stated in the '357 patent, “varying the magnitude and sign of the delays and gains of the processing paths leads to a wide variety of virtual microphones (VMs), also referred to herein as virtual directional microphones.” *Id.* at 9:22–25.

In particular, for adaptive noise suppression, the delay and gain values are selected so that the noise responses of V_1 and V_2 are substantially similar, there is sufficient speech response for V_1 , and there is a relatively small speech response for V_2 , which ensures that the cleaned speech will have significantly higher signal-to-noise ratio than the original speech

Explore Litigation Insights

Docket Alarm provides insights to develop a more informed litigation strategy and the peace of mind of knowing you're on top of things.

Real-Time Litigation Alerts



Keep your litigation team up-to-date with **real-time alerts** and advanced team management tools built for the enterprise, all while greatly reducing PACER spend.

Our comprehensive service means we can handle Federal, State, and Administrative courts across the country.

Advanced Docket Research



With over 230 million records, Docket Alarm's cloud-native docket research platform finds what other services can't. Coverage includes Federal, State, plus PTAB, TTAB, ITC and NLRB decisions, all in one place.

Identify arguments that have been successful in the past with full text, pinpoint searching. Link to case law cited within any court document via Fastcase.

Analytics At Your Fingertips



Learn what happened the last time a particular judge, opposing counsel or company faced cases similar to yours.

Advanced out-of-the-box PTAB and TTAB analytics are always at your fingertips.

API

Docket Alarm offers a powerful API (application programming interface) to developers that want to integrate case filings into their apps.

LAW FIRMS

Build custom dashboards for your attorneys and clients with live data direct from the court.

Automate many repetitive legal tasks like conflict checks, document management, and marketing.

FINANCIAL INSTITUTIONS

Litigation and bankruptcy checks for companies and debtors.

E-DISCOVERY AND LEGAL VENDORS

Sync your system to PACER to automate legal marketing.