



IEEE TRANSACTIONS ON

ANTENNAS AND PROPAGATION

JANUARY 1982

VOLUME AP-30

NUMBER 1

(ISSN 0018-926X)

A PUBLICATION OF THE IEEE ANTENNAS AND PROPAGATION SOCIETY

UNIVERSITY OF CALIFORNIA
LOS ANGELES

JAN 20 1982

ENGINEERING &
MATHEMATICAL
SCIENCES LIBRARY TB

PAPERS

Space-Time Integral Equation Approach to Dielectric Targets	<i>H. Mieras and C. L. Bennett</i>	2
A Low Elevation Angle Propagation Measurement of 1.5-GHz Satellite Signals in the Gulf of Mexico	<i>D. J. Fang, F. T. Tseng, and T. O. Calvit</i>	10
Diakoptic Theory for Multielement Antennas	<i>G. Goubau, N. N. Puri, and F. K. Schwing</i>	15
An Alternative Approach to Linearly Constrained Adaptive Beamforming	<i>L. J. Griffiths and C. W. Jim</i>	27
Transmission into Staggered Parallel-Plate Waveguides	<i>L. Grun and S. W. Lee</i>	35
Radiation from an Open-Ended Waveguide with Beam Equalizer—A Spectral Domain Analysis	<i>W. L. Ko, V. Jamnejad, R. Mittra, and S. W. Lee</i>	44
Dielectric Tapered Rod Antennas for Millimeter-Wave Applications	<i>S. Kobayashi, R. Mittra, and R. Lampe</i>	54
Optimization Techniques and Inverse Problems: Reconstruction of Conductivity Profiles in the Time Domain	<i>D. Lesselier</i>	59
Feed Region Modes in Dipole Phased Arrays	<i>E. D. Mayer and A. Hessel</i>	66
Scattering of a Dipole Field by a Moving Plasma Column	<i>K. Nakagawa</i>	76
Surface-Curvature-Induced Microwave Shadows	<i>M. H. Rahnvard and W. V. T. Rusch</i>	83
A Discussion of Various Approaches to the Identification/Approximation Problem	<i>T. K. Sarkar, D. D. Weiner, J. Nebat, and V. K. Jain</i>	89
Unified Theory of Near-Field Analysis and Measurement: Nonmathematical Discussion	<i>P. F. Wacker</i>	99
Precision Experimental Characterization of the Scattering and Radiation Properties of Antennas	<i>J. J. H. Wang, C. W. Choi, and R. L. Moore</i>	108
Efficient Computation of Antenna Coupling and Fields Within the Near-Field Region	<i>A. D. Yaghjian</i>	113
Adaptive Arrays: A New Approach to the Steady-State Analysis	<i>S. Zohar</i>	128

COMMUNICATIONS

Ground Wave Propagation over a Mixed Path with an Elevation Change	<i>D. A. Hill and J. R. Wait</i>	139
A Statistical Raindrop Canting Angle Model	<i>J. Howard and M. Gerogiokas</i>	141
Radiation from Flanged Waveguide: Comparison of Solutions	<i>S. W. Lee and L. Grun</i>	147
On the Integral Representation of Electromagnetic Field Vectors	<i>A. A. Mohsen</i>	148
Boresight-Gain Loss and Gore-Related Sidelobes of an Umbrella Reflector	<i>W. V. T. Rusch and R. D. Wanselow</i>	153
Exact Gain Measurement of Large Aperture Antennas Using Celestial Radio Sources	<i>T. Satoh and A. Ogawa</i>	157
Folded and T-Match Dipole Transformation Ratio	<i>R. C. Hansen</i>	161
Correction to "Dielectric Rod Leaky-Wave Antennas for Millimeter-Wave Applications"	<i>S. Kobayashi, R. Lampe, R. Mittra, and S. Ray</i>	162
Comments on the Bojarski Identity	<i>W.-M. Boerner</i>	162

IEEE COPYRIGHT FORM 163

ON

NUMBER 1

(ISSN 0018-926X)

ON SOCIETY

UNIVERSITY OF CALIFORNIA
 LOS ANGELES

JAN 20 1982

ENGINEERING &
 MATHEMATICAL
 SCIENCES LIBRARY TB

.....	<i>H. Mieras and C. L. Bennett</i>	2
ite Signals in the Gulf of Mexico		
.....	<i>D. J. Fang, F. T. Tseng, and T. O. Calvit</i>	10
.....	<i>G. Goubau, N. N. Puri, and F. K. Schwering</i>	15
ning	<i>L. J. Griffiths and C. W. Jim</i>	27
.....	<i>L. Grun and S. W. Lee</i>	35
Spectral Domain Analysis		
.....	<i>Ko, V. Jamnejad, R. Mittra, and S. W. Lee</i>	44



IEEE ANTENNAS AND PROPAGATION SOCIETY

All members of the IEEE are eligible for membership in the Antennas and Propagation Society and will receive this TRANSACTIONS upon payment of the annual Society membership fee of \$10.00. For information on joining, write to the IEEE at the address below.

ADMINISTRATIVE COMMITTEE

G. A. THIELE, *President*

1982

A. ISHIMARU
Y. T. LO
A. W. LOVE
A. J. SIMMONS

R. J. MAILLOUX, *Vice President*

1983

H. E. KING
C. E. RYAN, JR.
G. H. MILLMAN
I. C. PEDEN

1984

S. A. LONG
A. C. NEWELL
Y. RAHMAT-SAMII
D. H. SCHAUBERT

R. E. MCINTOSH, *Secretary-Treasurer*

Past Presidents

A. C. SCHELL
L. J. RICARDI
R. C. JOHNSON
R. C. HANSEN

Honorary Life Members: E. C. JORDAN, L. C. VAN ATTA

Committee Chairmen and Representatives

Committee on Man and Radiation: F. L. CAIN
Council on Oceanic Engineering: D. E. WEISSMAN, H. S. HAYRE
Geoscience and Remote Sensing: G. S. BROWN
Meetings: S. A. LONG
Membership: D. H. SCHAUBERT
Newsletter Editor: R. E. MCINTOSH

Nominations: R. C. JOHNSON
Standards—Antennas: E. S. GILLESPIE
Standards—Propagation: K. TOMAN
Publications: J. P. SHELTON
Standards Board: H. V. COTTONY
PAC Coordinator: W. R. STONE
Energy Committee: J. F. LINDSEY, R. S. COHEN
TAB-USAB R&D Committee: W. T. PATTON
USNC/URSI: A. W. LOVE
U.S. Activities Board: W. A. IMBRIALE

Awards and Fellows: A. J. SIMMONS
Chapter Activities: W. G. SCOTT
Constitution and Bylaws: R. I. WOLFSON
Distinguished Lecturers: R. L. FANTE
Education and Tutorial: Y. T. LO
Finance: R. E. MCINTOSH
Institutional Listings: G. S. BROWN
Long Range Planning: R. I. WOLFSON
APS-EMC Nuclear EMP: C. E. BAUM
Committee on Social Implications of Technology: D. G. BODNAR

Chapter Chairmen

Albuquerque
S. SINGARAJU
Atlanta
G. SMITH
Baltimore
S. STITZER
Benelux
A. GUISSARD

Boston
D. FYE
Chicago
B. LEVIN
Columbus
P. H. PATHAK
Dallas
E. MCBRIDE

Denver
G. HUFFORD
Houston
S. A. LONG
Los Angeles
O. GRAHAM

Melbourne
J. MARA
Montreal
R. BELANGER
Philadelphia
M. AFIFI

Phoenix
A. C. BROWN, JR.
St. Louis
J. BOGDANOR
San Diego
G. VANCE
Santa Clara/SF
G. AUGUST

Seattle
D. K. REYNOLDS
S. E. Michigan
V. LIEPA
Tokyo
S. ADACHI
Washington, DC
A. CHEUNG

IEEE TRANSACTIONS* ON ANTENNAS AND PROPAGATION

is a publication devoted to theoretical and experimental advances in antennas including design and development, and in the propagation of electromagnetic waves including scattering, diffraction, and interaction with continuous media; and applications pertinent to antennas and propagation, such as remote sensing applied optics, and millimeter and submillimeter wave techniques.

RAJ MITTRA, *Editor*
(See inside back cover)

Associate Editors

S. ADACHI, *International Editor*
W-M. BOERNER, *Inverse Scattering*
G. S. BROWN, *Geophysical Scattering*
C. M. BUTLER, *Tutorial*
R. L. FANTE, *Propagation*

H. E. KING, *Application Notes*
G. H. KNITTEL, *Phased Arrays*
C. H. LIU, *Propagation*
A. W. LOVE, *Reflector Antennas*

L. W. PEARSON, *Transients*
R. J. POGORZELSKI, *EM Theory*
Y. RAHMAT-SAMII, *Reflectors and HF Technique*
D. L. SENGUPTA, *Numerical Methods*
D. R. WILTON, *Analytical and Numerical Method*

THE INSTITUTE OF ELECTRICAL AND ELECTRONICS ENGINEERS, INC.

Officers

ROBERT E. LARSON, *President*
JAMES B. OWENS, *President-Elect*
THELMA A. ESTRIN, *Executive Vice President*
CHARLES A. ELDON, *Treasurer*
DICK C. J. POORTVLIET, *Secretary*

EDWARD W. ERNST, *Vice President, Educational Activities*
EDWARD J. DOYLE, *Vice President, Professional Activities*
G. P. RODRIGUE, *Vice President, Publication Activities*
HANS C. CHERNEY, *Vice President, Regional Activities*
JOSE B. CRUZ, JR., *Vice President, Technical Activities*

ALLAN C. SCHELL, *Division IV Director*

Headquarters Staff

ERIC HERZ, *Executive Director and General Manager*
ELWOOD K. GANNETT, *Deputy General Manager*

THOMAS W. BARTLETT, *Controller*
DONALD CHRISTIANSEN, *Editor of Spectrum*
IRVING ENGELSON, *Staff Director, Technical Activities*
LEO FANNING, *Staff Director, Professional Activities*
ELWOOD K. GANNETT, *Acting Staff Director, Publishing Services*

DONALD L. SUPPERS, *Staff Director, Field Services*
SAVA SHERR, *Staff Director, Standards*
EMILY L. SIRJANE, *Staff Director, Corporate Services*
CHARLES F. STEWART, JR., *Staff Director, Administration Service*
JOHN F. WILHELM, *Staff Director, Educational Services*

Publications Department

H. JAMES CARTER, *Associate Staff Director*
Production Managers: ANN H. BURGMAYER*, CAROLYNE ELENOWITZ, GAIL S. FERENC, ISABEL NAREA
Associate Editors: MARY E. GRANGEIA, THOMAS R. GRECO, ELAINE A. MAROTTA, JEFFREY B. MARTIN, EVELYN C. NORMAN, BARBARA A. SOMOGYI

* Responsible for this TRANSACTIONS

IEEE TRANSACTIONS ON ANTENNAS AND PROPAGATION is published bimonthly by The Institute of Electrical and Electronics Engineers, Inc. Headquarters: 345 East 47 Street, New York, NY 10017. Responsibility for the contents rests upon the authors and not upon the IEEE, the Society, or its members. IEEE Service Center (for orders, subscriptions, address changes, Region/Section/Student Services): 445 Hoes Lane, Piscataway, NJ 08854. Telephones: Headquarters 212-644 + extension; Information -7900, General Manager -7910, Controller -7748, Educational Services -7860, Publishing Services -7560, Standards -7960, Technical Services -7890. IEEE Service Center 201-981-0060. Professional Services: Washington Office 202-758-0017. NY Telecopier 212-752-4949. Telex: 236-411 (International messages only). Individual copies: IEEE members \$6.00 (first copy only), nonmembers \$12.00 per copy. Annual subscription price IEEE members, dues plus Society fee. Price for nonmembers on request. Available in microfiche and microfilm. COPYRIGHT AND REPRINT PERMISSIONS: Abstracting is permitted with credit to the source. Libraries are permitted to photocopy beyond the limits of U.S. Copyright Law for private use of patrons: (1) those post-1977 articles that carry a code at the bottom of the first page, provided the per copy fee indicated in the code is paid through the Copyright Clearance Center, 21 Congress Street, Salem, MA 01970; (2) pre-1978 articles without fee. Instructors are permitted to photocopy at IEEE Headquarters. All rights reserved. Copyright © 1981 by The Institute of Electrical and Electronics Engineers, Inc. Printed in U.S.A. Second-class postage paid at New York, NY and at additional mailing offices.

An Alternative Approach to Linearly Constrained Adaptive Beamforming

LLOYD J. GRIFFITHS, SENIOR MEMBER, IEEE, AND CHARLES W. JIM

Abstract—A beamforming structure is presented which can be used to implement a wide variety of linearly constrained adaptive array processors. The structure is designed for use with arrays which have been time-delay steered such that the desired signal of interest appears approximately in phase at the steered outputs. One major advantage of the new structure is the constraints can be implemented using simple hardware differencing amplifiers. The structure is shown to incorporate algorithms which have been suggested previously for use in adaptive beamforming as well as to include new approaches. It is also particularly useful for studying the effects of steering errors on array performance. Numerical examples illustrating the performance of the structure are presented.

INTRODUCTION

THIS PAPER describes a simple time-varying beamformer which can be used to combine the outputs of an array of sensors. The beamformer is constrained to filter the "desired" signal with a filter having a prescribed gain and phase response. The "desired" signal is identified by time-delay steering the sensor outputs so that any signal incident on the array from the direction of interest appears as an identical replica at the outputs of the steering delays. All other signals received by the array which do not have this property are considered to be noise and/or interference. The purpose of the beamformer is to minimize the effects of noise and interference at the array output while simultaneously maintaining the prescribed frequency response in the direction of the desired signal.

Beamformers of this type are termed linearly constrained array processors and have been studied by several authors including Levin [1], Lacoss [2], Kobayashi [3], Booker and Ong [4], Frost [5], and Applebaum and Chapman [6]. The last five of these authors describe iterative or continuously adaptive beamformers in which the beamforming coefficients adjust to new values as each new set of samples of array sensor outputs are received. Adaptive methods are of particular interest in those problems in which the interference properties are either spatially or temporarily time varying.

The purpose of this paper is to present the linearly constrained adaptive algorithm, due to Frost [5], using an alternative beamforming model. This presentation illustrates the fundamental properties of the algorithm in an exceedingly simple fashion. It also allows for generalizations not available with Frost's method. The basic structure of the beamforming model has been suggested by Applebaum and Chapman [6]. In this paper we describe the structure in detail and give exact algorithm comparisons for a variety of linearly constrained

beamformers. The structure is shown to be a direct consequence of Frost's method. One major advantage of our approach is an assessment of the performance degradation caused by the steering and/or gain errors in the array sensors. In most practical situations the theoretically ideal requirement of an "identical replica" of the desired signal, at the output of each steering delay, is seldom met. The effects of these errors on overall beamformer performance is easily modeled using our approach. For example, it is shown that these effects are particularly detrimental under conditions of high signal-to-noise ratio (SNR).

A second reason for this presentation is to enumerate certain difficulties which may arise with the use of constrained adaptive array processors which do not incorporate Frost's error-correction feature. Of the papers referenced above, four (see [2]–[4] and [7]) use an algorithm based on the gradient projection approach [8]. (Levin's approach was nonadaptive and utilized matrix inversion techniques.)

In this paper we first review Frost's algorithm which is not susceptible to roundoff error and requires relatively few additional computations per adaptive cycle. A simple geometric interpretation illustrating the effects of roundoff errors on his algorithm and on gradient projection is presented. The error-correcting properties of the approach are identified using this illustration.

We then show that the algorithm can be interpreted using a new beamforming model, termed the adaptive sidelobe canceling beamformer. This structure illustrates the constraint features of the algorithm and shows how additional constraints can be added. The error-correcting features are also elucidated. Sidelobe canceling is shown to be closely related to the method of adaptive noise canceling described by Widrow *et al.* [9]. As a consequence results derived in adaptive noise canceling can be applied directly to the linearly constrained adaptive beamformer.

LINEARLY CONSTRAINED ADAPTIVE BEAMFORMING

We denote the sampled output of the m th time-delayed sensor by $x_m(k)$. A total of M sensors are assumed to be present in the assumptions of ideal steering:

$$x_m(k) = s(k) + n_m(k). \quad (1)$$

In this expression $s(k)$ is the desired signal and $n_m(k)$ represents the totality of noise and interference observed at the output of the m th steered sensor. A beamformed output signal $y(k)$ is formed as the sum of delayed and weighted $x_m(k)$. Specifically, if $a_{m,l}$ is used to represent the weight used for the m th channel at delay l , then

$$y(k) = \sum_{m=1}^M \sum_{l=-K}^K a_{m,l} x_m(k-l). \quad (2)$$

Manuscript received May 19, 1980; revised March 5, 1981. This work was supported in part by the Office of Naval Research, Washington, DC, under Contract N00014-77-C-0592 and by the Electronics System Division (AFSC), Hanscom AFB, MA under Subcontract 14029 with SRI International, Menlo Park, CA.

L. J. Griffiths and C. W. Jim are with the Department of Electrical Engineering, University of Colorado, Boulder, CO 80309.

Note that a total of $2K + 1$ samples are used from each channel and that the zero time reference is at the filter midpoint.

Matrix notation can be used to simplify this notation. We let \mathbf{A}_l and $\mathbf{X}(k-l)$ represent the filter coefficient and signal vectors at the l th delay point, i.e.,

$$\mathbf{A}_l^T = [a_{1,l}, a_{2,l}, \dots, a_{M,l}] \quad (3)$$

$$\mathbf{X}^T(k-l) = [x_1(k-l), x_2(k-l), \dots, x_M(k-l)] \quad (4)$$

where superscript T denotes transpose. The output signal of (2) then becomes

$$y(k) = \sum_{l=-K}^K \mathbf{A}_l^T(l) \mathbf{X}(k-l). \quad (5)$$

Under the ideal steering assumption in (1), the signal vector $\mathbf{x}(k-l)$ becomes

$$\mathbf{X}(k-l) = s(k-l)\mathbf{1} + \mathbf{N}(k-l) \quad (6)$$

where $\mathbf{1}$ is a column vector of M ones and $\mathbf{N}(k-l)$ is a vector of noise and interference defined in a manner analogous to (4).

Prescribed gain and phase response for the desired signal is ensured by constraining the sums of channel weights at each delay point to be specific values. Thus if $f(l)$ is used to denote the sum for the set of weights at delay l then

$$\mathbf{A}_l^T(l)\mathbf{1} = f(l). \quad (7)$$

Under this constraint the portion of the output due to desired signal reduces to

$$Y_s(k) = \sum_{l=-K}^K f(l)s(k-l). \quad (8)$$

Thus the $f(l)$ represent the impulse response of a finite-duration impulse-response (FIR) filter having length $2K + 1$. One commonly used constraint is that of zero distortion in which $f(l) = \delta(l)$, where $\delta(l)$ is the discrete impulse function. The FIR filter constraint function is normalized such that

$$\mathbf{F}^T \mathbf{1} = 1, \quad (9a)$$

$$\mathbf{F}^T = [f(-K), \dots, f(K)]. \quad (9b)$$

The objective of linearly constrained adaptive beamforming is then to find filter coefficients $\mathbf{A}(l)$ which satisfy (7) and simultaneously reduce the average value of the square of the output noise component. This is equivalent to finding those coefficients which result in minimum output noise power subject to the constraint of the prescribed desired signal filtering.

In adaptive beamforming the filter coefficients are time varying and change as each new set of samples of sensor outputs is received. Thus if $\mathbf{A}_l(k)$ is used to denote the values at time k the values at the next sampling instant $k + 1$ are computed as

$$\mathbf{A}_l(k+1) = \mathbf{A}_l(k) + \Delta_l(k) \quad (10)$$

where $\Delta_l(k)$ is determined by the specific algorithm in use. In

this paper we are concerned with Frost's procedure [5], in which

$$\begin{aligned} \Delta_l(k) = & \mu y(k) [q_x(k-l)\mathbf{1} - \mathbf{X}(k-l)] \\ & - q_{a,l}(k)\mathbf{1} + \frac{1}{M} f(l)\mathbf{1} \end{aligned} \quad (11)$$

and

$$q_x(k-l) = \frac{1}{M} \mathbf{X}^T(k-l)\mathbf{1} \quad (12)$$

$$q_{a,l}(k) = \frac{1}{M} \mathbf{A}_l^T(k)\mathbf{1}. \quad (13)$$

The adaptive step size μ is a scalar which controls both the convergence rate and steady-state noise behavior of the algorithm [9] and is normalized by the total power contained in the beamformer. Thus

$$\mu = \frac{\alpha}{P(k)} \quad (14)$$

$$P(k) = \sum_{m=1}^M \sum_{l=-K}^K x_m^2(k-l). \quad (15)$$

Convergence of either algorithm is assured if $0 < \alpha < 1$. Other power estimates involving time averaging may be employed without significantly affecting performance.

Frost's procedure differs from that used in gradient projection [7] by the addition of the last two terms in (11). These terms involve a total number of additional $(2K + 1)M$ adds and $2K + 1$ multiples. They are necessary, however, in that they prevent the accumulation of computational errors which may occur on any iteration of the algorithm.

Error Effects in Linearly Constrained Beamforming

The effects of errors may be illustrated by examining the constraints (7) for the adaptive algorithm in (10) and (11). We assume that in the algorithm implementation, the computation of the signal sum $q_x(k-l)$ and the weight sum $q_{a,l}(k)$ in (13) introduced the following errors:

$$q_x(k-l) = \frac{1}{M} \mathbf{X}^T(k-l)\mathbf{1} + \epsilon_x(k) \quad (16a)$$

$$q_{a,l}(k) = \frac{1}{M} [\mathbf{A}_l^T(k)\mathbf{1} + \epsilon_A(k)] \quad (16b)$$

or equivalently, the current weight vector $\mathbf{A}_l(k)$ is presumed to be slightly off the constraint, i.e.,

$$\mathbf{A}_l^T(k)\mathbf{1} = f(l) + \epsilon_A(k). \quad (16c)$$

The degree to which the next weight vector fails to meet the constraint can then be computed by solving for $\mathbf{A}_l^T(k+1)\mathbf{1}$ in (10) and (11). Thus, using (16),

$$\begin{aligned} \mathbf{A}_l^T(k+1)\mathbf{1} = & f(l) + \epsilon_A(k) + \mu M y(k) \epsilon_x(k) \\ & + \{-f(l) - \epsilon_A(k) + f(l)\}. \end{aligned} \quad (17)$$

The terms enclosed in $\{\cdot\}$ are produced by error correction position of Frost's algorithm while the first three are due to the gradient projection algorithm. Thus if a gradient projection adaptation algorithm is employed—as was the case in [2]–[4] and [7]—the constraint error at step $k + 1$ is

$$\epsilon_A(k + 1) = \epsilon_A(k) + \mu M y(k) \epsilon_x(k) \tag{18}$$

and with Frost's procedure

$$\epsilon_A(k + 1) = \mu M y(k) \epsilon_x(k). \tag{19}$$

The cumulative error effects of gradient projection observed by Shen [7] are due to the first-order difference relationship in (18). If we assume that the driving term $\mu M y(k) \epsilon_x(k)$ can be modeled as a zero-mean white random process with variance σ_e^2 , and that $\epsilon_A(0) = 0$, then the gradient projection constraint error (18) is a Brownian motion [10] or random walk process. Although the mean of the error remains zero, its variance $\sigma_A^2(k)$ grows linearly with the number of steps, i.e.,

$$\sigma_A^2(k) = k \sigma_e^2 \tag{20a}$$

for gradient projection. With the correction terms, however, the error at each step has constant variance at each iteration,

$$\sigma_A^2(k) = \sigma_e^2. \tag{20b}$$

A simple geometric interpretation [5] can also be given for these effects. Consider the geometry associated with the gradient projection algorithm shown in Fig. 1. Coefficient vectors meeting the desired constraint must lie on the planar subspace C defined by the vector $F(9b)$. It is assumed that the coefficient vector $A_j(k)$ at time k is too long and that the gradient vector produced by the data is $g_j(k)$ given by

$$g_j(k) = \mu y(k) X(k - 1). \tag{21}$$

In the gradient projection method the new coefficient vector $A_j(k)$ is obtained by finding the projection of $g_j(k)$ in the direction of the plane C , and then by adding this projection to the previous vector. As shown by Fig. 1 the resulting new coefficient vector will not lie on the constraint plane, even with an error-free projection operation.

Fig. 2 illustrates the geometry for Frost's approach. In this case the new coefficient vector is found by projecting the sum of the former vector and the gradient in the direction of the constraint plane C . The new coefficient vector $A_j(k)$ is then the sum of this projected vector and the vector F , which defines C . As shown in the diagram the new coefficients will lie on the constraint plane regardless of the previous error provided that the projection operation is error free. The net error induced by this method is then restricted to the machine quantization error of a single projection operation and accumulation does not occur.

GENERALIZED SIDELobe CANCELING MODEL

The linearly constrained adaptive algorithm defined by (10)–(13) may be implemented using the structure shown in Fig. 3. Time-delay steering elements $\tau_1, \tau_2, \dots, \tau_M$ are used to point the array in the direction of interest. We will refer to this implementation as the direct form. Each coefficient in

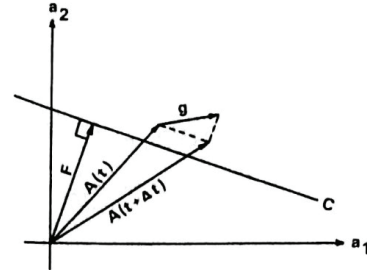

Fig. 1. Geometrical interpretation for gradient projection adaptive algorithm.

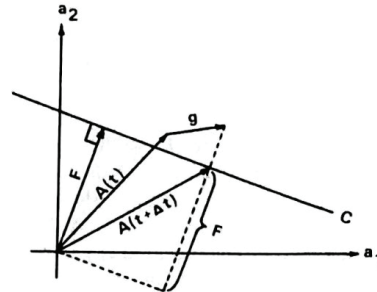

Fig. 2. Geometrical interpretation for linearly constrained error-correcting adaptive algorithm.

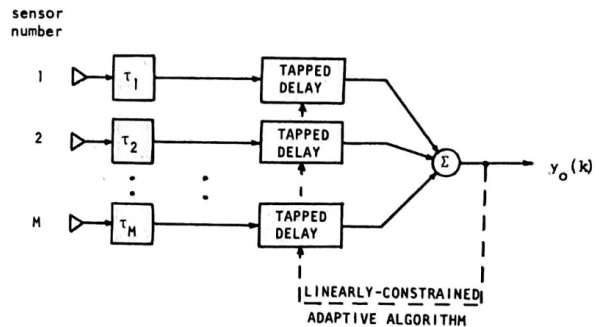

Fig. 3. Direct form implementation of linearly constrained adaptive array processing algorithm.

the beamformer is updated by the adaptive processor, which computes new values using the algorithm. An alternative implementation which achieves precisely the same overall processor can be derived in a simple manner directly from this algorithm. The resulting structure is termed the generalized sidelobe canceling form and is depicted in Fig. 4.

This processor consists of two distinct substructures which are shown as the upper and lower processing paths. The upper or conventional beamformer path consists of a set of fixed amplitude weights $w_{c1}, w_{c2}, \dots, w_{cM}$ which produce non-adaptive-beamformed signal $y_c(k)$,

$$y_c(k) = W_c^T X(k) \tag{22}$$

where

$$W_c^T = [w_{c1}, w_{c2}, \dots, w_{cM}]. \tag{23}$$

This conventional array beamforming system is identical to that traditionally used to process sensor array outputs with

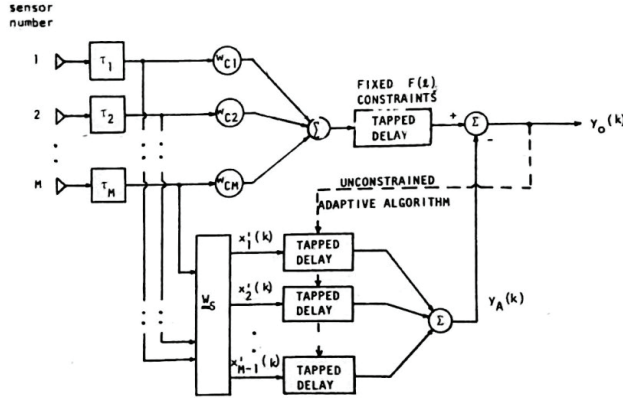

Fig. 4. Generalized sidelobe canceling form of linearly constrained adaptive array processing algorithm.

fixed nonadaptive coefficients. In typical applications the weights W_c are chosen so as to trade off the relationship between array beamwidth and average sidelobe level [11]. (One widely used method employs Chebyshev polynomials to find the W_c .) For the purpose of this paper, however, any method can be used to choose the weights as the performance of the overall beamformer will be characterized in terms of the specific values chosen. (All w_{ci} are assumed nonzero.) In order to simplify notation the coefficients in W_c are normalized to have a sum of unity. That is

$$W_c^T \mathbf{1} = 1. \quad (24)$$

The signal $y_c'(k)$ is obtained by filtering $y_c(k)$ and the FIR operator containing the constraint values $f(l)$,

$$y_c'(k) = \sum_{l=-K}^K f(l)y_c(k-l). \quad (25)$$

The lower path in Fig. 4 is the sidelobe canceling path. It consists of a matrix preprocessor \bar{W}_s followed by a set of tapped-delay lines, each containing $2K + 1$ weights. The purpose of \bar{W}_s is to block the desired signal $s(k)$ from the lower path. Since $s(k)$ is common to each of the steered sensor outputs (1) blocking is ensured if the rows of \bar{W}_s sum up to zero. Specifically if $\mathbf{X}'(k)$ is used to denote the set of signals at the output of \bar{W}_s , then

$$\mathbf{X}'(k) = \bar{W}_s \mathbf{X}(k). \quad (26)$$

In addition, if \mathbf{b}_m^T is used to represent the m th row of \bar{W}_s , we require that the \mathbf{b}_m^T satisfy

$$\mathbf{b}_m^T \mathbf{1} = 0, \quad \text{for all } m, \quad (27)$$

and that the \mathbf{b}_m are linearly independent. As a result $\mathbf{X}'(k)$ can have at most $M - 1$ linearly independent components. Equivalently, the row dimension of \bar{W}_s must be $M - 1$ or less.

The lower path of the generalized sidelobe canceler generates a scalar output $y_A(k)$ as the sum of delayed and weighted elements of $\mathbf{X}'(k)$. Following the notation used to describe the linearly constrained beamformer,

$$y_A(k) = \sum_{l=-K}^K [\mathbf{A}_l'(k)]^T \mathbf{X}'(k-l), \quad (28)$$

where \mathbf{X}' and \mathbf{A}' are the $M - 1$ dimensional signal and coefficient vectors.

The overall output of the generalized sidelobe canceling structure $y(k)$ is

$$y(k) = y_c'(k) - y_A(k). \quad (29)$$

Because $y_A(k)$ contains no desired signal terms, the response of the processor to the desired signal $s(k)$ is that produced only by $y_c'(k)$. Thus from (22)–(25) the output due to the presence of only the desired signal satisfies the constraint defined by (9), regardless of W_c . In addition, since $y_A(k)$ contains only noise and interference terms, finding the set of filter coefficients $\mathbf{A}_l'(k)$ which minimize the power contained in $y(k)$ is equivalent to finding the minimum variance, linearly constrained beamformer. The unconstrained least-mean-square (LMS) algorithm [12] can be employed to adapt the filter coefficients to the desired solution,

$$\mathbf{A}_l'(k) = \mathbf{A}_l'(k) + \mu y(k) \mathbf{X}'(k-l). \quad (30)$$

The step size μ is normalized by the total power contained in the $\mathbf{X}'(k-l)$ using methods analogous to those described above.

The algorithm in (30), together with conditions (24) and (27), completely defines the operation of the generalized sidelobe canceling structure. Although it is not obvious, this structure can provide exactly the same filtering operation as the constrained beamformer in Fig. 3, which uses Frost's algorithm. In addition, it can also provide filtering operations which are not the same as Frost's procedure. The key lies with the structure of the blocking matrix \bar{W}_s and the conventional beamformer W_c . If the rows of \bar{W}_s are orthogonal (in addition to satisfying (27)) and if all conventional beamformer weights equal $1/M$, then Frost's method is obtained. Non-orthogonal rows and/or other conventional beamformers produce a processor having the same steady-state performance in a stationary environment, but one which uses a different adaptive trajectory.

The generalized sidelobe canceler separates out the constraint as element \bar{W}_s and an FIR filter. In addition, it provides a conventional beamformer as an integral portion of its structure. Coefficient adaptation is reduced to its simplest possible form: the unconstrained LMS algorithm.

Relationship with Linearly Constrained Beamforming

The structure of the generalized sidelobe canceler can readily be related to the adaptive linearly constrained beamformer. We begin by defining an invertible $M \times M$ matrix \bar{T} as

$$\bar{T} = \begin{bmatrix} W_c^T \\ -\bar{W}_s \end{bmatrix}. \quad (31)$$

The inverse of \bar{T} is guaranteed for W_c and \bar{W}_s satisfying (24) and (27). In addition, the product $\bar{T}\mathbf{1}$ is a simple unit vector,

$$\bar{T}\mathbf{1} = [1, 0, 0, \dots, 0]^T. \quad (32)$$

Multiplying Frost's algorithm by this invertible transformation yields

$$\begin{aligned} \mathbf{B}_l(k+1) = & \mathbf{B}_l(k) + \mu y(k) [q_x(k-l)\bar{T}\mathbf{1} - \bar{T}\mathbf{X}(k-l)] \\ & - q_{a,l}(k)\bar{T}\mathbf{1} + \frac{1}{M} f(l)\bar{T}\mathbf{1}. \end{aligned} \quad (33)$$

The transformed weight vector $B_I(k)$ can be partitioned in a manner analogous to (31) as follows

$$B_I(k) = \begin{bmatrix} b_I'(k) \\ \bar{B}_I'(k) \end{bmatrix} \quad (34)$$

With this partitioning, and (32), the transformed algorithm (33) is recognized as two algorithms: one in the scalar $b_I'(k)$ and one in the $M - 1$ dimensional vector $\bar{B}_I'(k)$,

$$b_I'(k + 1) = b_I'(k) + \mu y(k)[q_x(k - 1) - y_c(k - 1)] \quad (35a)$$

$$\bar{B}_I'(k + 1) = \bar{B}_I'(k) + \mu y(k)\bar{X}'(k - 1). \quad (35b)$$

These equations may be viewed as an alternative implementation of Frost's procedure. Since \bar{T} is invertible, the output $y(k)$ may be expressed as

$$y(k) = \sum_{l=-K}^K [\bar{T}^{-1} B_I(k)]^T X(k - l). \quad (36)$$

Thus if (35) is used to update the $B_I(k)$ and the output is computed using (36), this procedure is indistinguishable from the original. Many more computations would be required, however, and the transformed system offers no advantages.

We now consider the simplification which arises when \bar{T} is an orthogonal transformation, i.e., when $\bar{T}^{-1} = \bar{T}^T$. The output equation (36) simplifies to

$$y(k) = \sum_{l=-K}^K b_I'(k) y_c(k - l) - \sum_{l=-K}^K [B'(k)]^T X'(k - l). \quad (37)$$

Inspection of (35)–(37) shows that the transformed linearly constrained beamformer in this case is identical to the adaptive-sidelobe canceling beamformer, provided that the $b_I'(k)$ satisfy

$$b_I(k) = f(l), \quad (38)$$

for all values of k . Since the $b_I(k)$ must satisfy (35a), this will occur only if they are initialized to the values in (38) and if

$$q_x(k - 1) = y_c(k - 1). \quad (39)$$

This condition is equivalent to the requirement that

$$W_c = \frac{1}{M} \mathbf{1} \quad (40)$$

or, equivalently, that all beamformer weights have equal values of $1/M$.

In summary the above discussion has shown that the adaptive-sidelobe canceler will be identical to Frost's algorithm provided that the conventional weights satisfy (40) and that \bar{T} is an orthogonal transformation. (From (31) and (4), this latter condition is equivalent to requiring that the rows of \bar{W}_s sum up to zero and be mutually orthogonal.) It is to be noted

that this is a sufficient condition only, and necessity has not been considered.

Jim [13] has studied the comparison in detail and shown that steady-state performance of the two processors is identical regardless of the structure of W_c and \bar{W}_s , provided that the system operates at full rank. He has also shown that different eigenvalue spectra will be encountered by the adaptive filters in the two systems unless W_c and \bar{W}_s meet the sufficient equality conditions previously described. As a result the coefficient trajectories and adaptive learning curves will differ.

PROPERTIES AND EXTENSIONS OF ADAPTIVE CONSTRAINED BEAMFORMERS

The previous section has presented a generalized sidelobe canceling structure which can be used to implement the error-correcting linearly constrained adaptive algorithm in (10)–(12). This structure can also be used to both analyze the performance of the algorithm and to suggest generalizations of constrained beamforming. We begin by summarizing the performance characteristics of the algorithm which are readily delineated by the sidelobe canceling model. These properties are then used to extend the concept of linearly constrained adaptive beamforming and to develop new methods for use in array processing.

One key element in the sidelobe canceler is the signal-blocking matrix \bar{W}_s . As shown by (27), this matrix is required to have $M - 1$ linearly independent rows which sum up to zero. Of the many matrices which can be generated with this property, two possibilities which involve only addition operations are shown below for the case $M = 4$:

$$\bar{W}_s^{(1)} = \begin{bmatrix} 1 & 1 & -1 & -1 \\ 1 & -1 & -1 & 1 \\ 1 & -1 & 1 & 1 \end{bmatrix} \quad (41)$$

$$\bar{W}_s^{(2)} = \begin{bmatrix} 1 & -1 & 0 & 0 \\ 0 & 1 & -1 & 0 \\ 0 & 0 & 1 & 1 \end{bmatrix}. \quad (42)$$

In the first matrix the rows are mutually orthogonal and are elements of the binary-valued Walsh functions [14]. The second matrix involves fewer operations and consists of taking the difference between adjacent sensor outputs.

One can interpret the rows of \bar{W}_s as fixed-weight beamformers which are applied to the sensor outputs. The beamformed signals are then the elements of $X'(k)$ and the constraints in (27) ensure the presence of a spatial null in the broadside direction for each beamformer. Note that $\bar{W}_s^{(1)}$ has a different spatial amplitude response for each row while $\bar{W}_s^{(2)}$ has identical patterns.

The effects of imperfect sensor steering and/or gain variations are easily modeled using the generalized sidelobe canceling structure. For example, gain differences at the outputs of the time-delayed sensors result in a set of received signals $x_m(t)$ given by

$$x_m(t) = s(t)(1 + \epsilon_m) + n_m(t) \quad (43)$$

where ϵ_m represents the gain departure from unity at the m th sensor output. Because of the nonzero ϵ_m , the desired signal

appears in both the conventional beamformer output $y_c(t)$ and in the sidelobe canceling path. The presence of desired signal in the adaptive filters has been termed "signal leak through" by Widrow *et al.* [9], and may result in signal distortion and/or reduction in output SNR. The distortion is due to the fact that the scalar $y_A(k)$ contains a weighted sum of delayed-desired signal terms. It can be demonstrated, however, that these effects are negligible provided that the power level of the signal leak through is small compared with the power contained in the filtered noise vector $N'(k)$. Equivalently, if

$$\sigma_s^2 \text{tr} \{W_s R_{\epsilon\epsilon} W_s^T\} \ll \text{tr} W_s R_{NN} W_s^T \quad (44)$$

where σ_s^2 is the power level of the desired signal observed at a sensor output, $\text{tr} \{\cdot\}$ denotes trace, and $R_{\epsilon\epsilon}$ and R_{NN} are the autocorrelation matrices for the vector of gain errors ϵ and the received noise vector $N(k)$, respectively. For the case of uncorrelated, equal variance, gain errors, and white receiver noise, the result simplifies to

$$\sigma_\epsilon^2 \frac{\sigma_s^2}{\sigma_n^2} \ll 1 \quad (45)$$

where σ_ϵ^2 and σ_n^2 are the variance of the gain errors and white receiver noises. This result demonstrates a well-known property of constrained beamformers, i.e., that the system is much more sensitive to gain errors at high input signal-to-noise ratios.

New methods of adaptive beamforming are suggested by the generalized sidelobe canceling structure illustrated in Fig. 4. These include the following.

1) Additional spatial constraints can be incorporated into the W_s matrix. For example, one can require both a spatial null in the desired direction (as in the system discussed above) and a zero derivative in that direction. The matrix $\overline{W}_s^{(3)}$ for $M = 4$ achieves this result:

$$\overline{W}_s^{(3)} \begin{bmatrix} 1 & -2 & 1 & 0 \\ 0 & 1 & -2 & 1 \end{bmatrix}. \quad (46)$$

Note that the row dimension in this case is $M - 2$ due to the additional spatial constraint. The system sensitivity to pointing errors (time-delay steering errors), however, is markedly reduced.

2) Combined spatial/temporal constraint beamformers are achieved by including delay-storage elements in the \overline{W}_s matrix. Equivalently,

$$\mathbf{X}'(k) = \sum_{n=-N}^N W_{s,n} \mathbf{X}(k-n). \quad (47)$$

Thus far, to the authors' knowledge, studies into the advantages of combined constraints have not been reported.

3) Power minimization algorithms other than LMS may be used to adapt the filter coefficients. Since the constraints have been removed from the algorithm, unconstrained accelerated convergence techniques such as the conjugate gradient method [15] may offer significant advantages in tracking time variations.

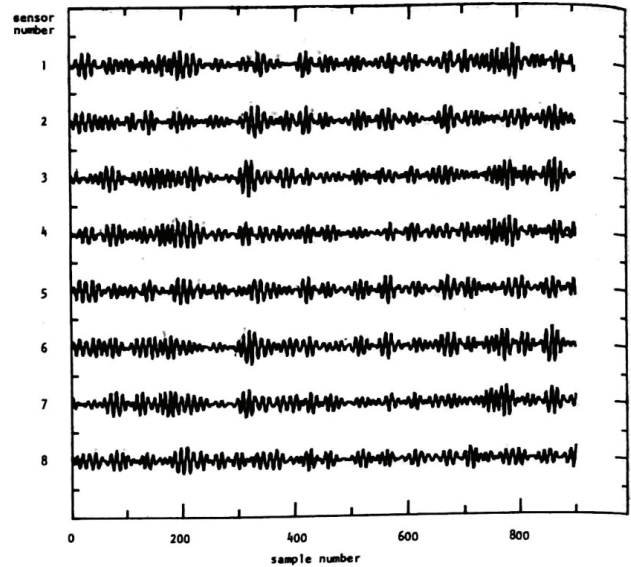

Fig. 5. Synthetic sensor outputs used to demonstrate algorithm performance.

SIMULATION RESULTS

In order to demonstrate the performance of the generalized sidelobe canceling beamformer described above, a synthetic set of eight sensor output samples was generated. The results are shown in Fig. 5. They consist of two statistically independent narrow-band spatially propagating, random noise sources, each assumed to be an incident on the array from a different direction. The array has been time-delay steered such that the desired signal pulse appears in phase at about 570 samples in all eight traces. At a normalized one sample per second sampling rate, the narrow-band random noise sources had a bandwidth of 0.03 Hz centered at 0.095 Hz. In addition, a small amount of independent white noise was added to each output to simulate the effects of receiver noise.

Fig. 6 shows the conventional beamformer output obtained by adding the eight outputs and dividing by eight. The narrow-band interference completely dominates the output and the desired signal is undetectable. Considerably better signal to noise ratio can be achieved with a linearly constrained adaptive beamformer, as shown by the results in Fig. 7. The upper waveform is the conventional beamformer output depicted in Fig. 6 and the lower two were generated with the use of the generalized sidelobe canceler and the gradient projection algorithm without error correction, respectively. All three traces are plotted using the same amplitude scaling factor and both adaptive beamformers employed a five-point time operator on each channel. The simple differencing technique described in (42) was used to generate the seven-difference channels. An identical normalized adaptive step size $\alpha = 0.2$ was used in the two-adaptive beamformers.

While the two adaptive outputs appear quite similar, small differences are readily apparent. As described in the previous section, these differences are directly attributable to the fact that the generalized sidelobe canceler used a \overline{W}_s matrix in which the rows were not mutually orthogonal (see (42)). Thus, although the steady-state performance is the same, different adaptive paths are employed by the two algorithms. In addition, gradient projection incurs accumulated roundoff

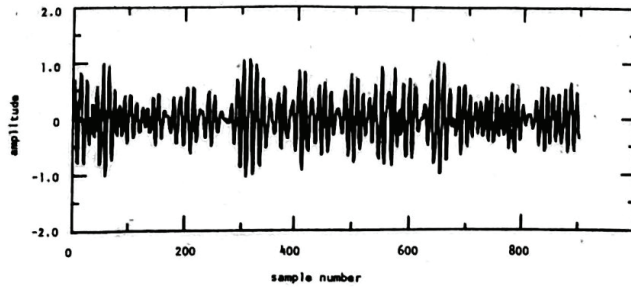

Fig. 6. Conventional beamformer output.

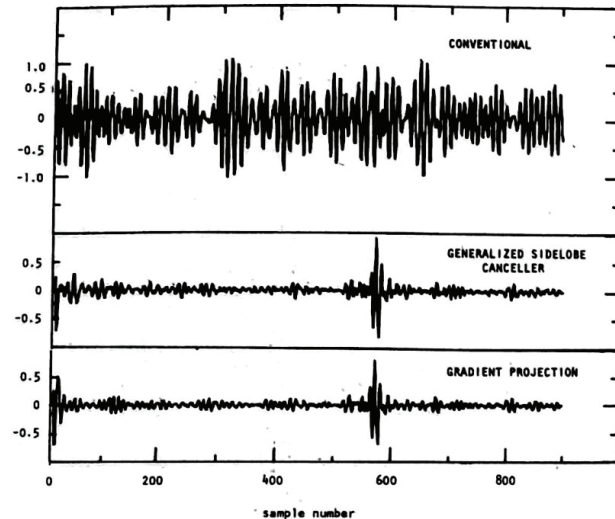

Fig. 7. Conventional and adaptive beamformer outputs.

error. Most noticeable of this error is the difference in peak signal amplitude. The ideal noise-free signal had an amplitude of 0.940. That measured for the two adapters was 0.938 for the generalized sidelobe canceler and 0.786 for the gradient projection algorithm. The small error in generalized sidelobe canceling is presumably due to the presence of the white noise component in the output.

Careful measurements of the average noise power in the 30-50 s window and of the signal amplitude reduction in gradient projection were conducted for values of α between 0.1 and 0.5. Fig. 8 summarizes these findings for the two algorithms. As described above, the generalized sidelobe canceler exhibits negligible signal amplitude degradation over the range of studied.

DISCUSSION AND CONCLUSION

The simulation results presented above illustrate the effects of accumulated error which can be observed with the use of the simple gradient projection algorithm. These effects are readily discernible even though the simulation experiments were conducted on a CDC 6400 general purpose computer having a 60-bit word length. The purpose of the simulation experiment was to demonstrate that the generalized sidelobe canceler does not incur similar roundoff penalties. No attempt has been made to study the well-known noise reduction properties of adaptive beamforming. Experiments conducted with minicomputers having smaller work length—for example, 16 bits—would lead to similar insensitivity to error.

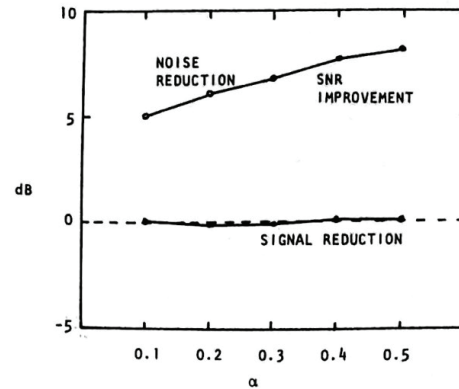

(a)

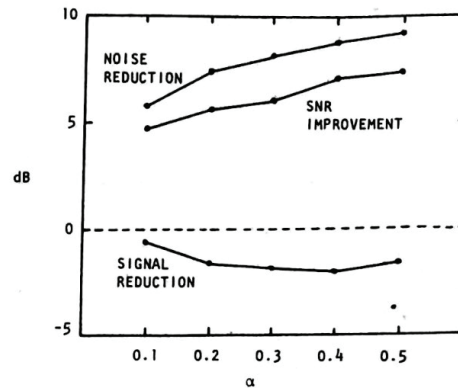

(b)

Fig. 8. Signal and noise power performance. (a) Gradient projection algorithm. (b) Generalized sidelobe canceling algorithm.

The generalized sidelobe canceling structure described in this paper can be viewed as an alternative implementation of Frost's linearly constrained adaptive beamforming algorithm. The structure has additional advantages, however, relating to both the development of other related beamformers and to the performance analysis of constrained adaptive beamformers.

REFERENCES

- [1] M. J. Levin, "Maximum-likelihood array processing," in *Seismic Discrimination Semi-Annual Technical Summary Report*, M.I.T. Lincoln Laboratory, Lexington, MA, Tech. Rep. DDC 455743, Dec. 1964.
- [2] R. T. Lacoss, "Adaptive combining of wideband array data for optimal reception," *IEEE Trans. Geosci. Electron.*, vol. GE-6, pp. 78-86, May 1968.
- [3] H. Kobayashi, "Iterative synthesis methods for a seismic array processor," *IEEE Trans. Geosci. Electron.*, vol. GE-8, pp. 169-178, July 1970.
- [4] A. Booker and C. Y. Ong, "Multiple constraint adaptive filtering," *Geophysics*, vol. 36, pp. 498-509, Apr. 1969.
- [5] O. L. Frost, III, "An algorithm for linearly-constrained adaptive array processing," *Proc. IEEE*, vol. 60, no. 8, pp. 926-935, Aug. 1972.
- [6] S. P. Applebaum and D. J. Chapman, "Adaptive arrays with main beam constraints," *IEEE Trans. Antennas Propagat.*, vol. AP-24, no. 5, pp. 650-662, Sept. 1976.
- [7] W. Shen, "A constrained minimum power adaptive beamformer with time-varying adaptation rate," *Geophysics*, vol. 11, pp. 1088-1095, June 1979.
- [8] D. G. Luenberger, *Optimization by Vector Space Methods*. New York: Wiley, 1969.

- [9] B. W. Widrow *et al.*, "Adaptive noise cancelling: Principles and applications," *Proc. IEEE*, vol. 63, no. 12, pp. 1692-1716, Dec. 1975.
- [10] A. Papoulis, *Probability, Random Variables, and Stochastic Processes*. New York: McGraw-Hill, 1965.
- [11] C. L. Dolph, "A current distribution for broadside arrays which optimizes the relationship between beamwidth and sidelobe level," *Proc. IRE*, vol. 34, pp. 335-348, June 1946.
- [12] B. Widrow and M. E. Hoff, "Adaptive switching circuits," in *1960 WESCON Conv. Rec.*, pt. 4, pp. 96-140, 1960.
- [13] C. W. Jim, "Random gain and phase error effects in optimal array structures," Dept. Elec. Eng., Univ. of Colorado, Boulder, *Tech. Rep. EE 77-2*, Dec. 1977.
- [14] H. F. Harmuth, *Transmission of Information by Orthogonal Functions*. New York: Springer-Verlag, 1969.



Lloyd J. Griffiths (S'66-M'68-SM'79) received the B.S. degree in electrical engineering from the University of Alberta, Edmonton, Canada in 1963, and the M.S. and Ph.D. degrees in electrical engineering from Stanford University, Stanford, CA in 1965 and 1968, respectively.

Since 1970, he has been a member of the faculty of the Department of Electrical Engineering at the University of Colorado, Boulder, where he is a Professor. His teaching and research interests are in the area of digital signal

processing and adaptive systems. He received the IEEE Browder J. Thompson Best Paper Award (1971), the Eta Kappa Nu Outstanding Young Educator Award (1975) and the Dow Outstanding Young Faculty Award (1976). During the 1979-1980 academic year, he received a Faculty Fellowship from the University of Colorado and was appointed Visiting Professor to the Digital Signal Processing Group in the Electrical Engineering Department at M.I.T., Cambridge, MA. He was coeditor of a Joint Special Issue on Adaptive Signal Processing which was published by the IEEE Acoustics, Speech, and Signal Processing and IEEE Circuits and Systems Societies in June 1981.

Dr. Griffiths is a member of Eta Kappa Nu and Sigma Xi.



Charles W. Jim was born in Cantho, S. Vietnam, on Jan. 5, 1947. He received the B.S. degree with honors and the M.S. degree, both in electrical engineering from the University of Colorado, Boulder, in 1974 and 1976, respectively.

During the summer of 1974 he was employed by IBM in Boulder. While at IBM he was involved in recording channel development research. From 1974 to 1975 he was a teaching assistant, teaching circuits and electronics labs.

Since May 1975, he has been a Research Assistant. His research area covers digital signal processing techniques applied to the antenna array problem. He has published several technical reports and papers.