



US 20060277355A1

(19) **United States**

(12) **Patent Application Publication**
Ellsberry et al.

(10) **Pub. No.: US 2006/0277355 A1**

(43) **Pub. Date: Dec. 7, 2006**

(54) **CAPACITY-EXPANDING MEMORY DEVICE**

G06F 12/06 (2006.01)

(76) Inventors: **Mark Ellsberry**, Santa Clara, CA (US);
Paul Sweere, Irvine, CA (US); **Michael Sansur**, Costa Mesa, CA (US); **Grant Stockton**, Fountain Valley, CA (US)

(52) **U.S. Cl.** 711/5; 711/154

(57) **ABSTRACT**

Correspondence Address:

LOZA & LOZA
6285 EAST SPRING STREET, # 327N
LONG BEACH, CA 90808 (US)

The invention relates to a device, system, and method for expanding the memory capacity of a memory module. A control unit and memory bank switch are mounted on a memory module to selectively control write and/or read operations to/from memory devices communicatively coupled to the memory bank switch. By selectively routing data to and from the memory devices, a plurality of memory devices may appear as a single memory device to the operating system. That is, the invention expands the addressable memory banks on a module by making two smaller-capacity memory devices emulate a single higher-capacity memory device.

(21) Appl. No.: **11/142,989**

(22) Filed: **Jun. 1, 2005**

Publication Classification

(51) **Int. Cl.**
G06F 13/00 (2006.01)

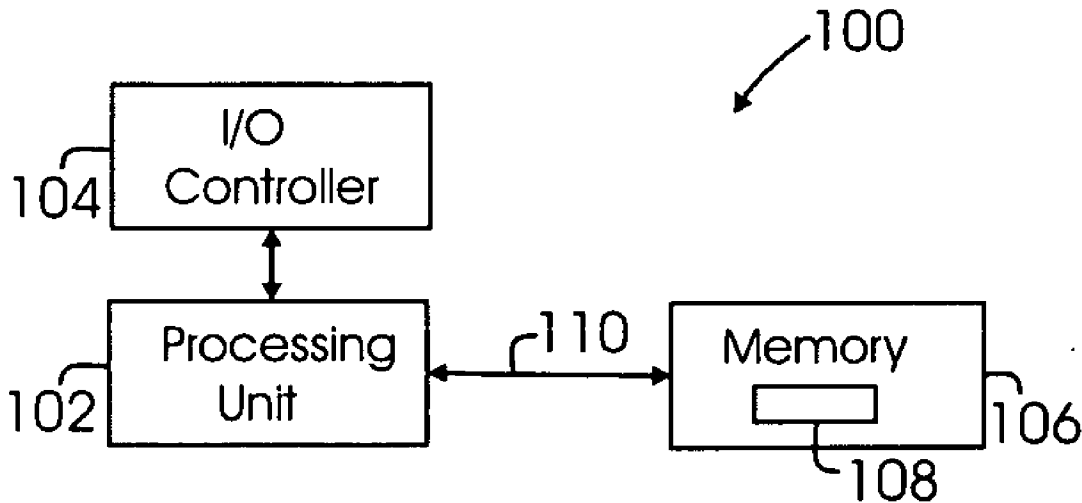

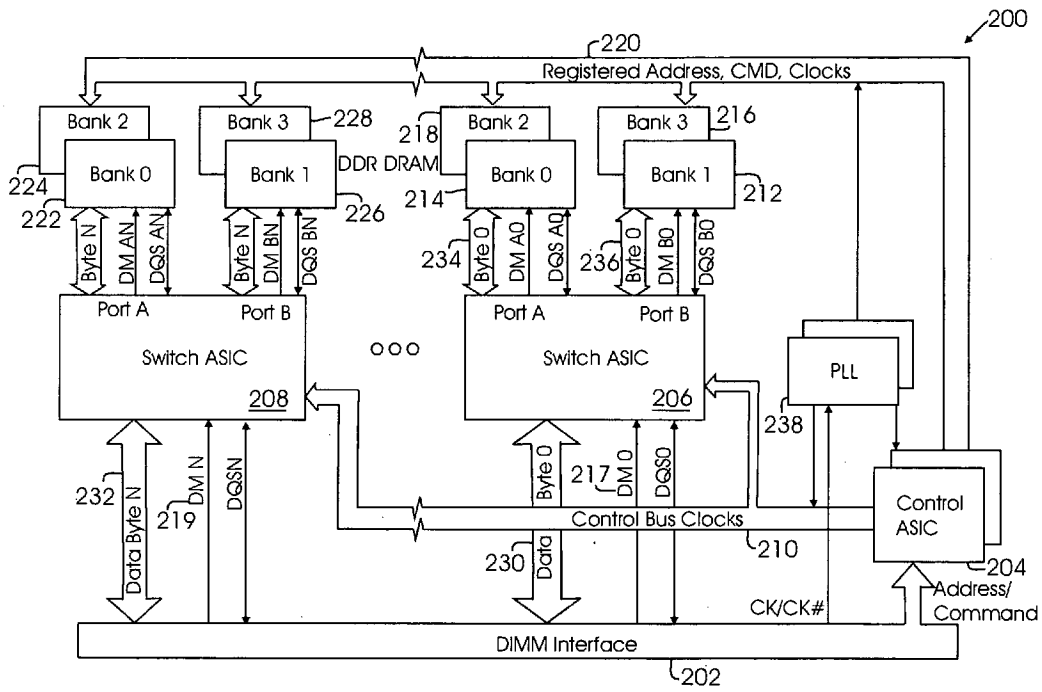

Fig. 2

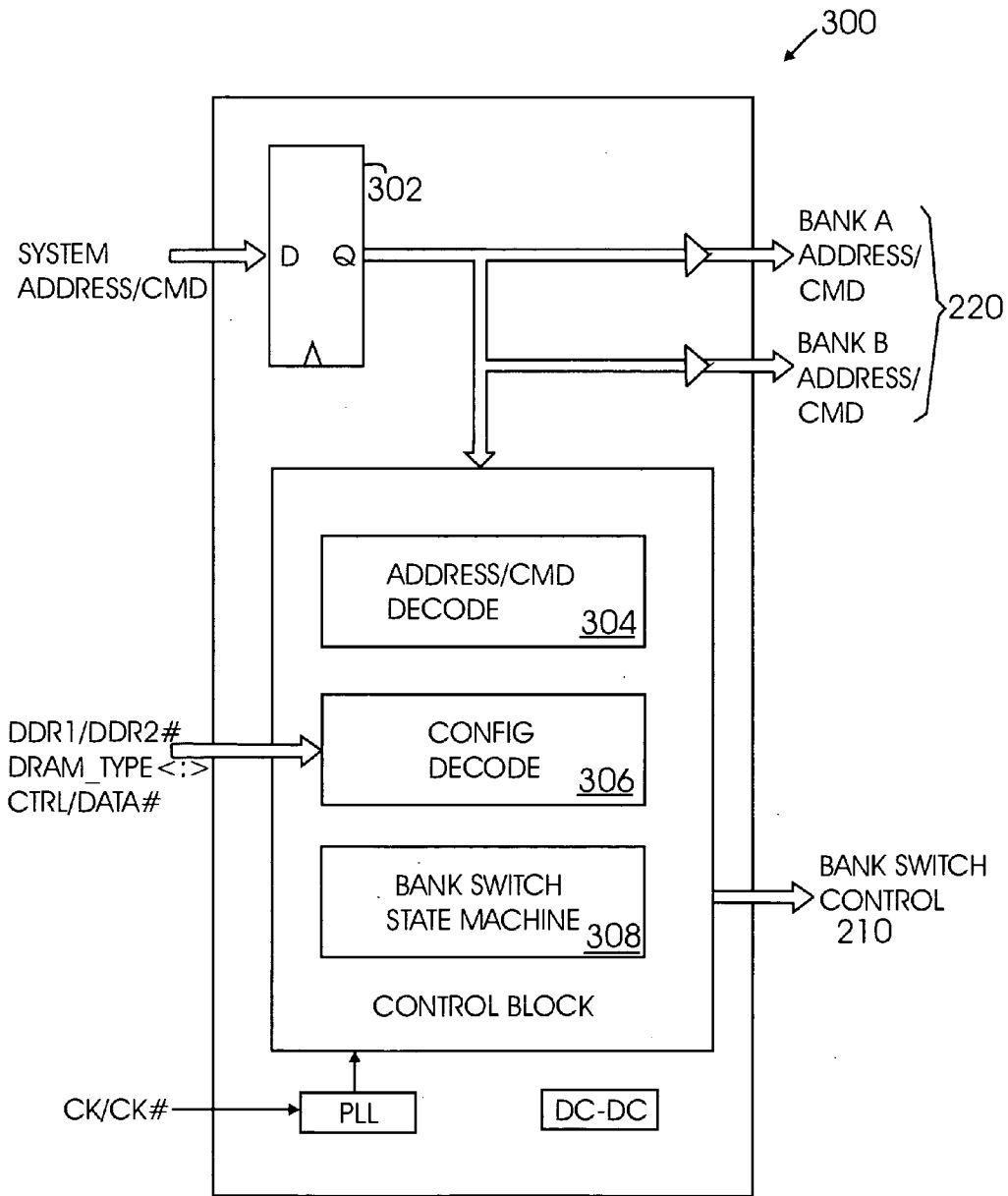

Fig. 3

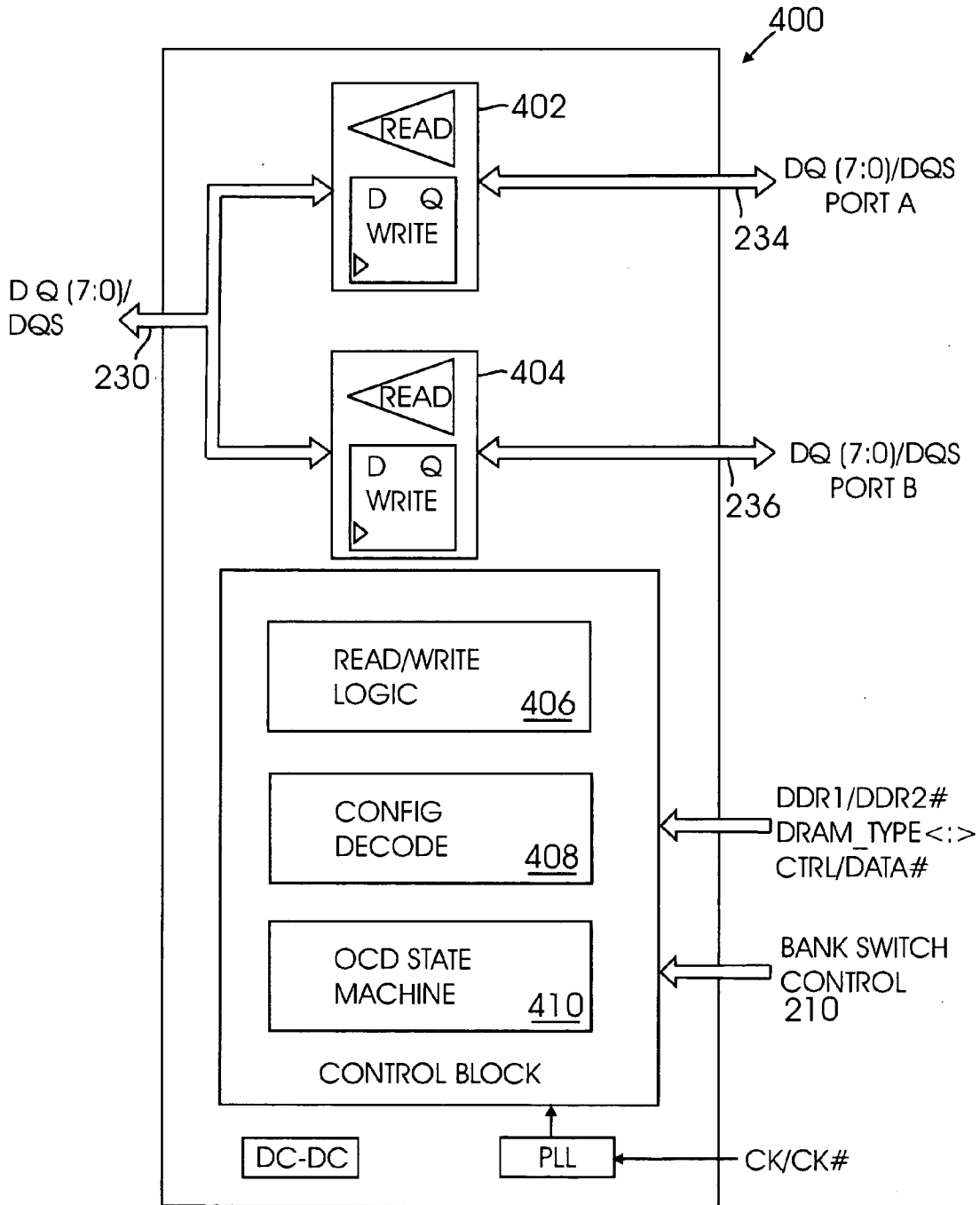

Fig. 4

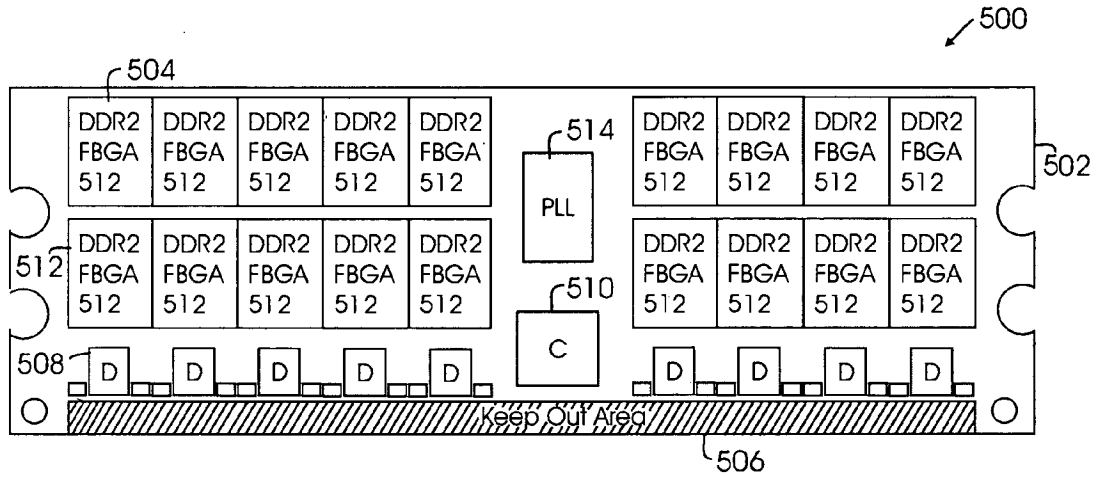

Fig. 5

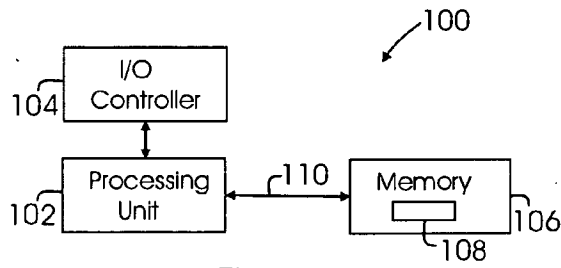

Fig. 1

Explore Litigation Insights

Docket Alarm provides insights to develop a more informed litigation strategy and the peace of mind of knowing you're on top of things.

Real-Time Litigation Alerts



Keep your litigation team up-to-date with **real-time alerts** and advanced team management tools built for the enterprise, all while greatly reducing PACER spend.

Our comprehensive service means we can handle Federal, State, and Administrative courts across the country.

Advanced Docket Research



With over 230 million records, Docket Alarm's cloud-native docket research platform finds what other services can't. Coverage includes Federal, State, plus PTAB, TTAB, ITC and NLRB decisions, all in one place.

Identify arguments that have been successful in the past with full text, pinpoint searching. Link to case law cited within any court document via Fastcase.

Analytics At Your Fingertips



Learn what happened the last time a particular judge, opposing counsel or company faced cases similar to yours.

Advanced out-of-the-box PTAB and TTAB analytics are always at your fingertips.

API

Docket Alarm offers a powerful API (application programming interface) to developers that want to integrate case filings into their apps.

LAW FIRMS

Build custom dashboards for your attorneys and clients with live data direct from the court.

Automate many repetitive legal tasks like conflict checks, document management, and marketing.

FINANCIAL INSTITUTIONS

Litigation and bankruptcy checks for companies and debtors.

E-DISCOVERY AND LEGAL VENDORS

Sync your system to PACER to automate legal marketing.