



US 20080263324A1

(19) **United States**

(12) **Patent Application Publication**
Sutardja et al.

(10) **Pub. No.: US 2008/0263324 A1**

(43) **Pub. Date: Oct. 23, 2008**

(54) **DYNAMIC CORE SWITCHING**

(76) Inventors: **Sehat Sutardja**, Los Altos Hills, CA (US); **Hong-Yi Chen**, Fremont, CA (US); **Premanand Sakarda**, Acton, MA (US); **Mark N. Fullerton**, Austin, TX (US); **Jay Heeb**, Gilbert, AZ (US)

May 1, 2008, provisional application No. 61/058,050, filed on Jun. 2, 2008, provisional application No. 60/825,368, filed on Sep. 12, 2006, provisional application No. 60/823,453, filed on Aug. 24, 2006, provisional application No. 60/822,015, filed on Aug. 10, 2006.

Correspondence Address:
HARNES, DICKEY & PIERCE P.L.C.
5445 CORPORATE DRIVE, SUITE 200
TROY, MI 48098 (US)

Publication Classification

- (51) **Int. Cl.**
G06F 9/00 (2006.01)
- (52) **U.S. Cl.** **712/43; 712/E09.001**

(21) Appl. No.: **12/145,660**

(22) Filed: **Jun. 25, 2008**

(57) **ABSTRACT**

A system includes a first asymmetric core, a second asymmetric core, and a core switching module. The first asymmetric core executes an application when the system operates in a first mode and is inactive when the system operates in a second mode. The second asymmetric core executes the application when the system operates in the second mode. The core switching module switches operation of the system between the first mode and the second mode. The core switching module selectively stops processing of the application by the first asymmetric core after receiving a first control signal. The core switching module transfers a first state of the first asymmetric core to the second asymmetric core. The second asymmetric core resumes executing the application in the second mode.

Related U.S. Application Data

- (63) Continuation-in-part of application No. 11/523,996, filed on Sep. 20, 2006.
- (60) Provisional application No. 60/968,143, filed on Aug. 27, 2007, provisional application No. 60/978,936, filed on Oct. 10, 2007, provisional application No. 60/981,606, filed on Oct. 22, 2007, provisional application No. 61/022,431, filed on Jan. 21, 2008, provisional application No. 61/029,476, filed on Feb. 18, 2008, provisional application No. 61/049,641, filed on

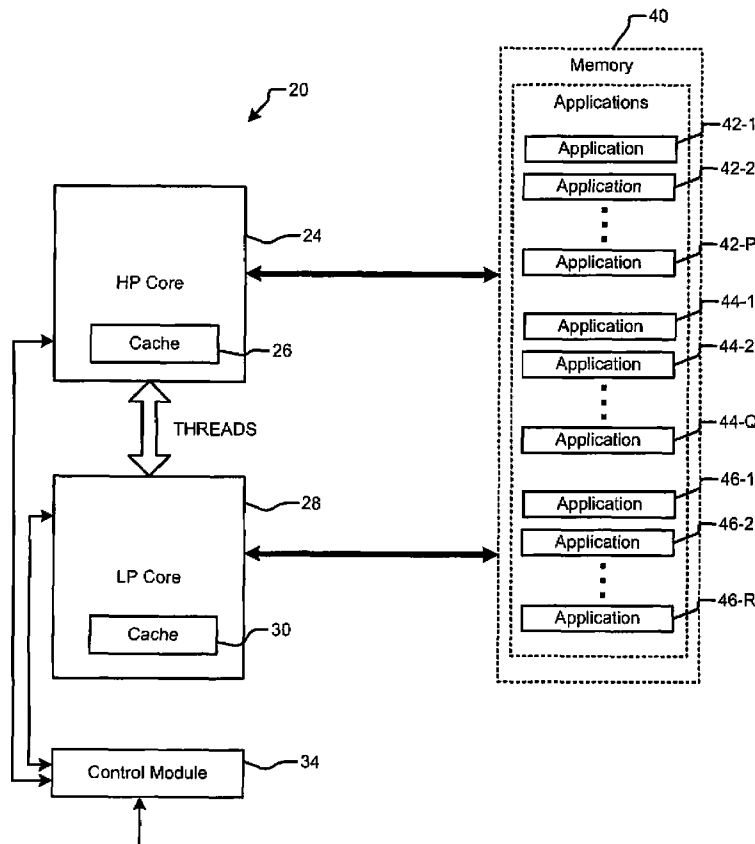

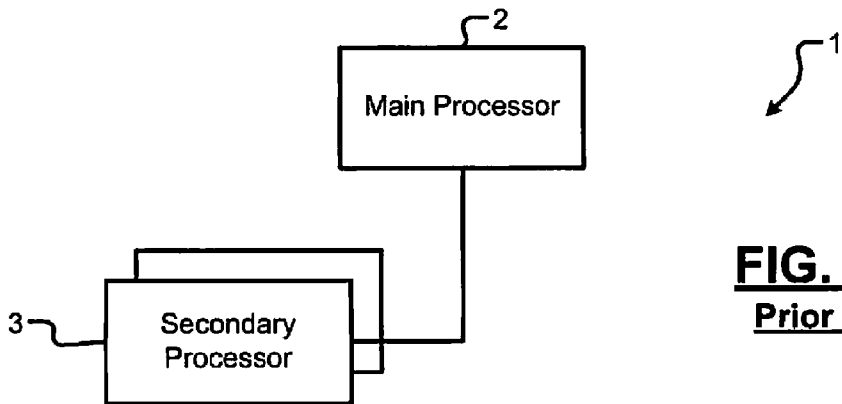

FIG. 1A
Prior Art

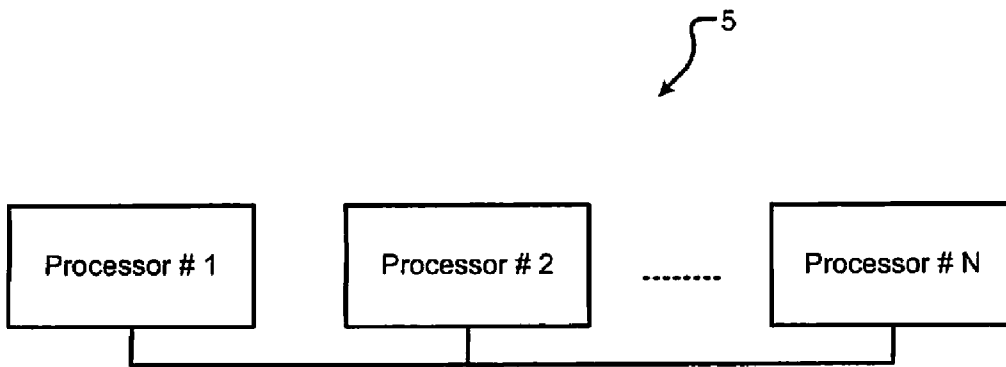

FIG. 1B
Prior Art

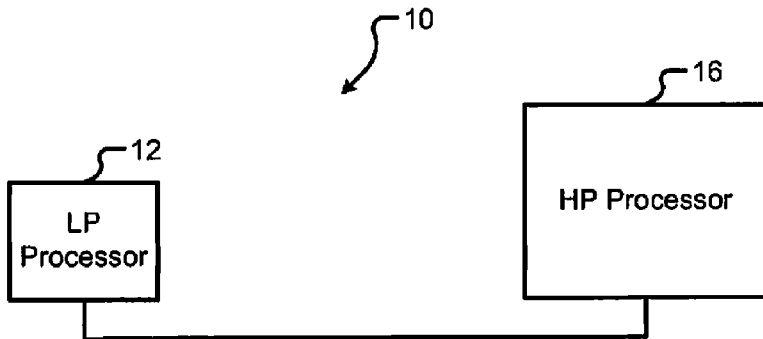

FIG. 2

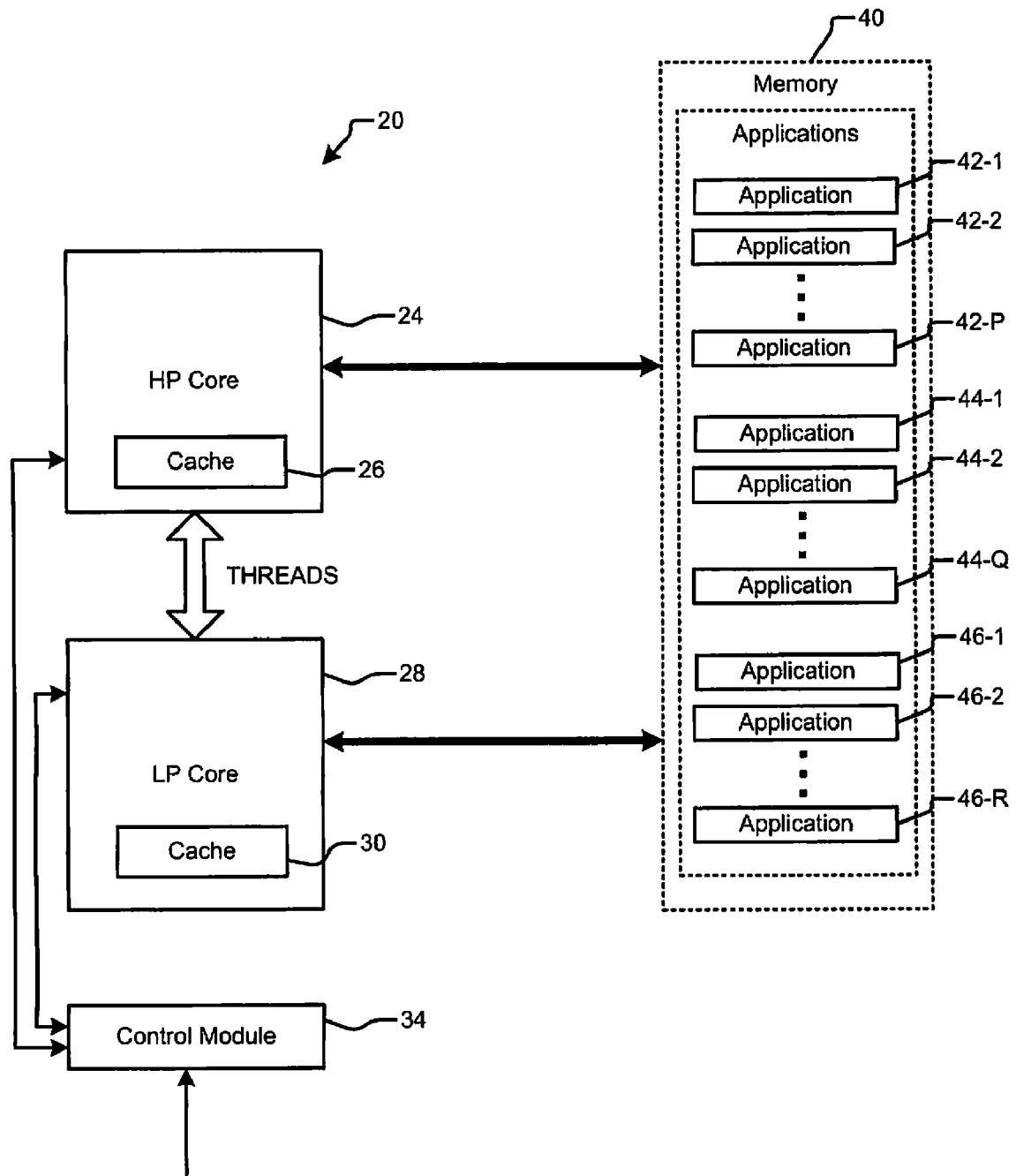

FIG. 3A

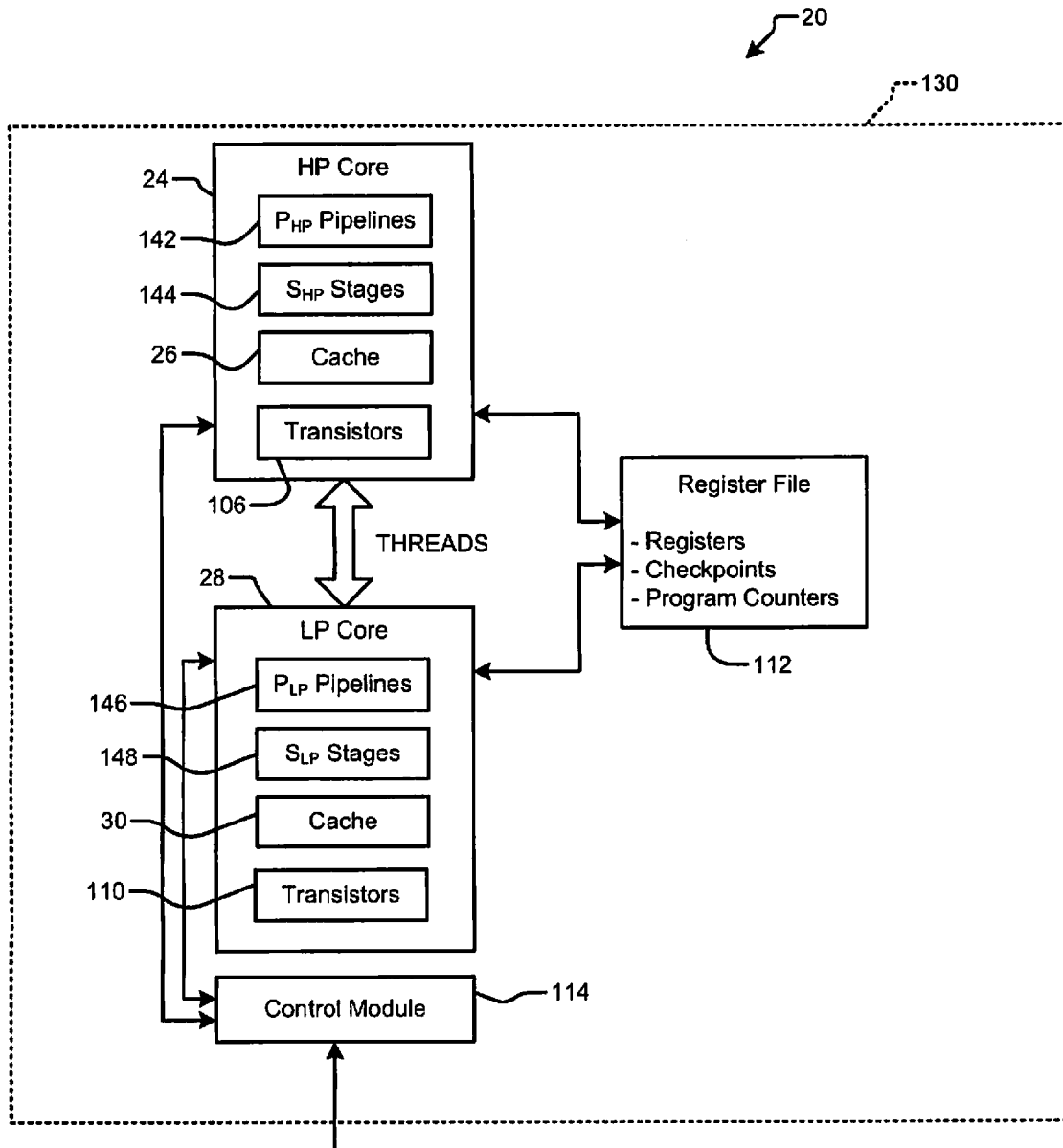

FIG. 3B

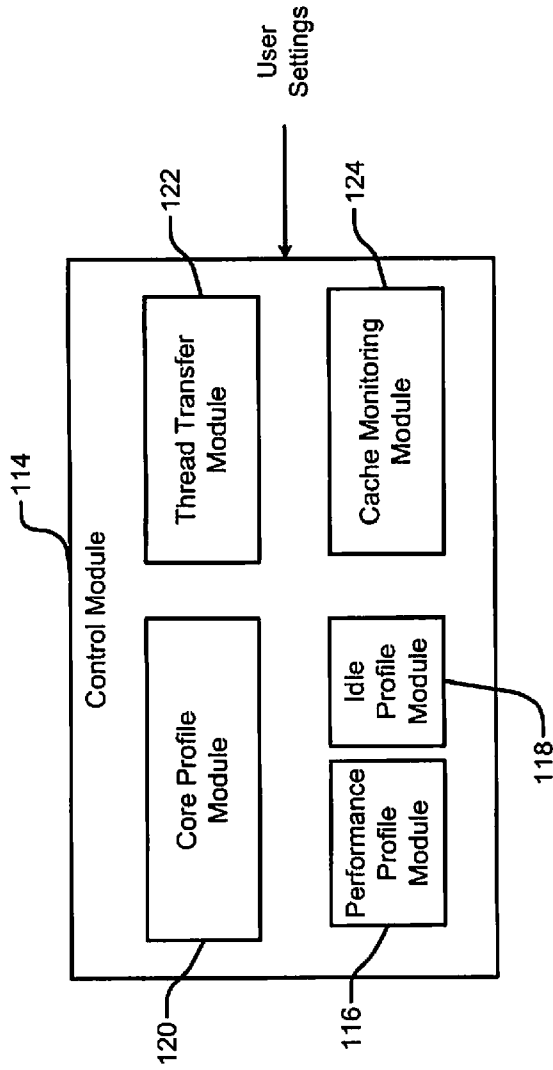

FIG. 3C

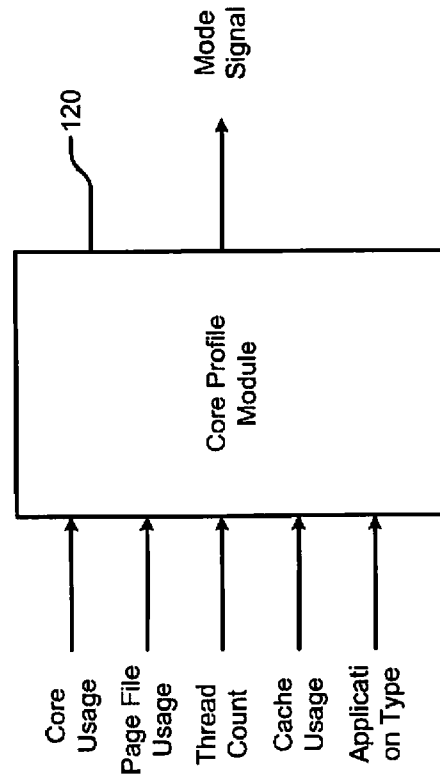

FIG. 3D

Explore Litigation Insights

Docket Alarm provides insights to develop a more informed litigation strategy and the peace of mind of knowing you're on top of things.

Real-Time Litigation Alerts



Keep your litigation team up-to-date with **real-time alerts** and advanced team management tools built for the enterprise, all while greatly reducing PACER spend.

Our comprehensive service means we can handle Federal, State, and Administrative courts across the country.

Advanced Docket Research



With over 230 million records, Docket Alarm's cloud-native docket research platform finds what other services can't. Coverage includes Federal, State, plus PTAB, TTAB, ITC and NLRB decisions, all in one place.

Identify arguments that have been successful in the past with full text, pinpoint searching. Link to case law cited within any court document via Fastcase.

Analytics At Your Fingertips



Learn what happened the last time a particular judge, opposing counsel or company faced cases similar to yours.

Advanced out-of-the-box PTAB and TTAB analytics are always at your fingertips.

API

Docket Alarm offers a powerful API (application programming interface) to developers that want to integrate case filings into their apps.

LAW FIRMS

Build custom dashboards for your attorneys and clients with live data direct from the court.

Automate many repetitive legal tasks like conflict checks, document management, and marketing.

FINANCIAL INSTITUTIONS

Litigation and bankruptcy checks for companies and debtors.

E-DISCOVERY AND LEGAL VENDORS

Sync your system to PACER to automate legal marketing.