



US009264400B1

(12) **United States Patent**
Lin et al.

(10) **Patent No.:** **US 9,264,400 B1**
(45) **Date of Patent:** **Feb. 16, 2016**

- (54) **SOFTWARE DEFINED NETWORKING PIPE FOR NETWORK TRAFFIC INSPECTION**
- (71) Applicant: **Trend Micro Incorporated**, Tokyo (JP)
- (72) Inventors: **Chuan-Hung Lin**, Taipei (TW); **Ching-Yi Li**, Taipei (TW); **Po-Cheng Liang**, Taipei (TW)
- (73) Assignee: **Trend Micro Incorporated**, Tokyo (JP)
- (*) Notice: Subject to any disclaimer, the term of this patent is extended or adjusted under 35 U.S.C. 154(b) by 121 days.

- 2011/0286324 A1 * 11/2011 Bellagamba H04L 41/0677 370/219
- 2012/0210416 A1 * 8/2012 Mihelich H04L 63/0218 726/11
- 2013/0291088 A1 * 10/2013 Shieh H04L 63/0218 726/11
- 2014/0133360 A1 * 5/2014 Chiueh H04L 41/12 370/256
- 2014/0211807 A1 * 7/2014 Takenaka H04L 45/74 370/392
- 2015/0124629 A1 * 5/2015 Pani H04L 12/4679 370/248
- 2015/0163150 A1 * 6/2015 Beheshti-Zavareh . H04L 45/121 370/400
- 2015/0222491 A1 * 8/2015 Clark H04L 45/48 370/256
- 2015/0236900 A1 * 8/2015 Chung H04L 69/02 709/221

(21) Appl. No.: **14/094,442**

(22) Filed: **Dec. 2, 2013**

(51) **Int. Cl.**
G06F 21/00 (2013.01)
H04L 29/06 (2006.01)

(52) **U.S. Cl.**
CPC **H04L 63/02** (2013.01); **H04L 63/0245** (2013.01)

(58) **Field of Classification Search**
CPC H04L 63/02; H04L 63/0245
See application file for complete search history.

(56) **References Cited**

U.S. PATENT DOCUMENTS

- 6,697,806 B1 * 2/2004 Cook G06F 21/31
- 6,751,219 B1 * 6/2004 Lipp H04L 49/201 370/390
- 8,339,959 B1 * 12/2012 Moisan H04L 63/0236 370/235
- 2003/0021230 A1 * 1/2003 Kuo H04L 47/10 370/230
- 2006/0036780 A1 * 2/2006 Demis G06F 13/4282 710/36
- 2009/0249472 A1 * 10/2009 Litvin H04L 63/0263 726/14
- 2009/0300353 A1 * 12/2009 Hart H04L 63/1416 713/168
- 2010/0269171 A1 * 10/2010 Raz G06F 17/00 726/13
- 2010/0278180 A1 * 11/2010 Ma H04L 49/354 370/392

OTHER PUBLICATIONS

OpenFlow—Wikipedia, the free encyclopedia, 3 sheets [retrieved on Nov. 15, 2013], retrieved from the internet: <http://en.wikipedia.org/wiki/OpenFlow>.
ONF—Open Networking Foundation, White Paper, Software-Defined Networking: The New Form Norm for Networks, Apr. 13, 2012, pp. 1-12.

* cited by examiner

Primary Examiner — Lisa Lewis

(74) Attorney, Agent, or Firm — Okamoto & Benedicto LLP

(57) **ABSTRACT**

A software defined networking (SDN) computer network includes an SDN controller and an SDN switch. The SDN controller inserts flow rules in a flow table of the SDN switch to create an SDN pipe between a sender component and a security component. A broadcast function of the SDN switch to the ports that form the SDN pipe may be disabled. The SDN pipe allows outgoing packets sent by the sender component to be received by the security component. The security component inspects the outgoing packets for compliance with security policies and allows the outgoing packets to be forwarded to their destination when the outgoing packets pass inspection. The SDN controller may also insert a flow rule in the flow table of the SDN switch to bypass inspection of specified packets.

17 Claims, 8 Drawing Sheets

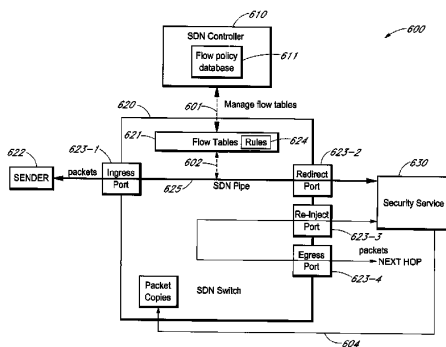

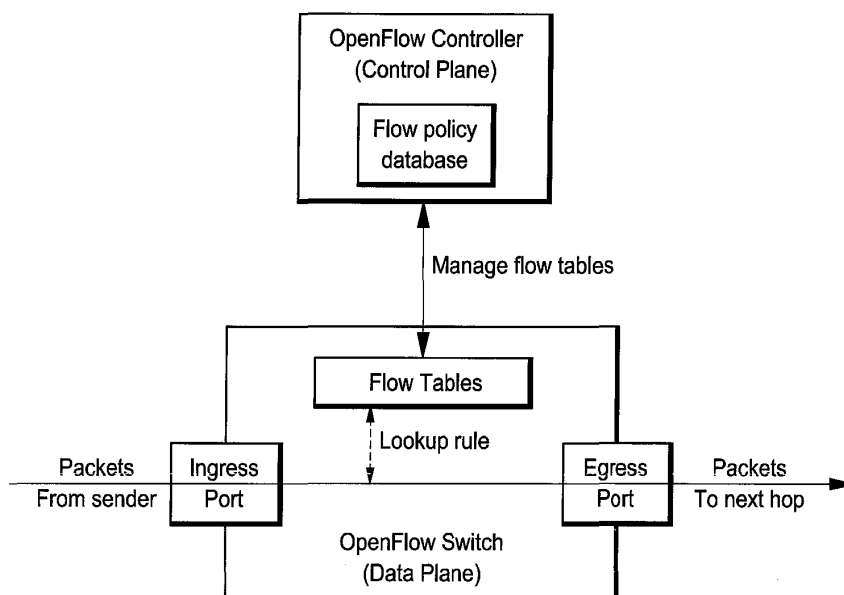

FIG. 1
(PRIOR ART)

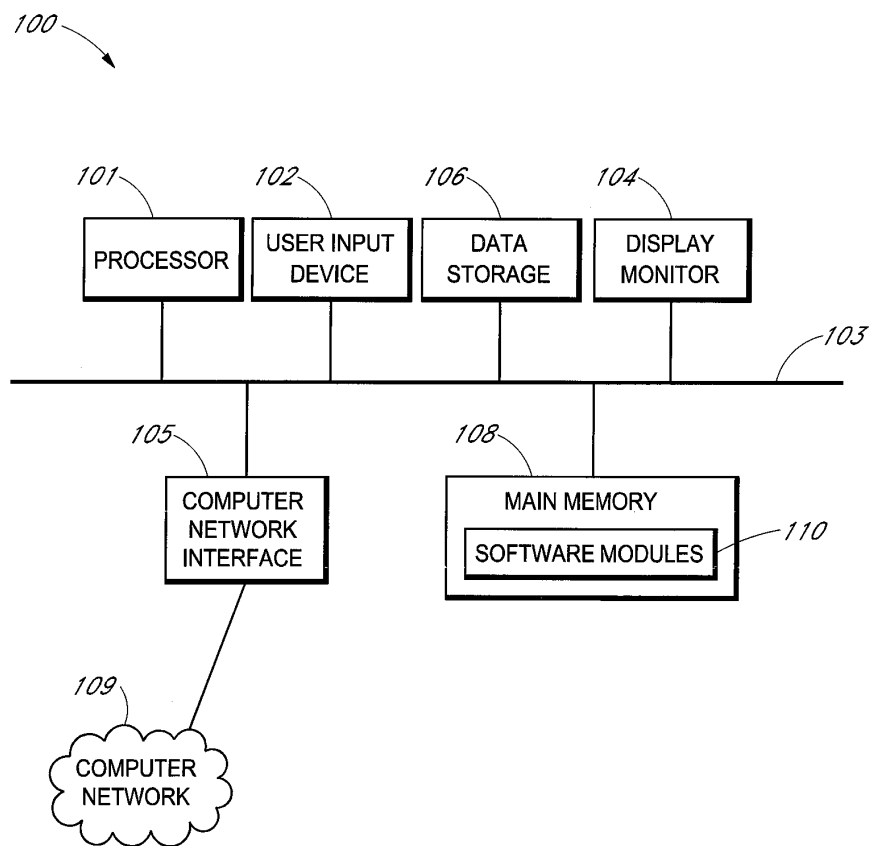

FIG. 2

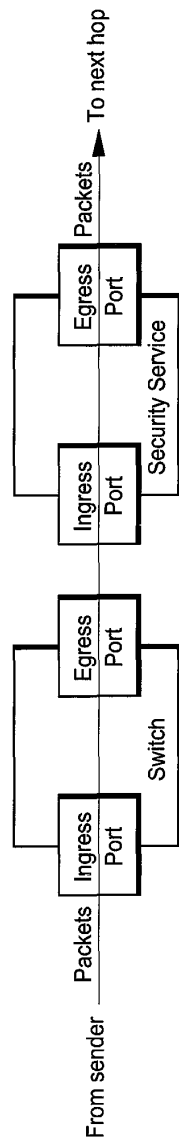

FIG. 3

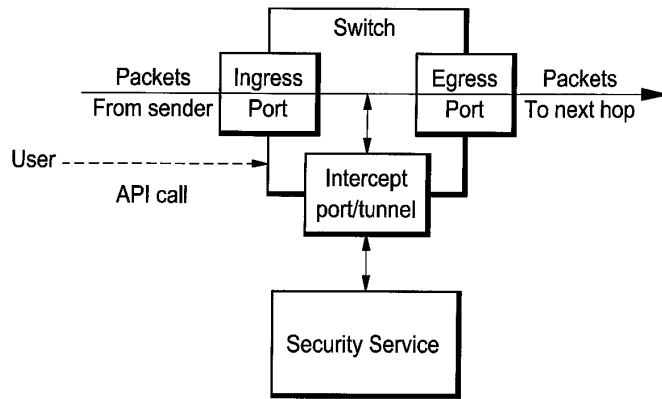

FIG. 4

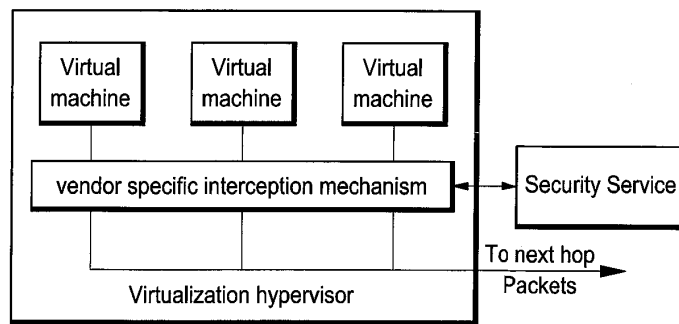

FIG. 5

Explore Litigation Insights

Docket Alarm provides insights to develop a more informed litigation strategy and the peace of mind of knowing you're on top of things.

Real-Time Litigation Alerts



Keep your litigation team up-to-date with **real-time alerts** and advanced team management tools built for the enterprise, all while greatly reducing PACER spend.

Our comprehensive service means we can handle Federal, State, and Administrative courts across the country.

Advanced Docket Research



With over 230 million records, Docket Alarm's cloud-native docket research platform finds what other services can't. Coverage includes Federal, State, plus PTAB, TTAB, ITC and NLRB decisions, all in one place.

Identify arguments that have been successful in the past with full text, pinpoint searching. Link to case law cited within any court document via Fastcase.

Analytics At Your Fingertips



Learn what happened the last time a particular judge, opposing counsel or company faced cases similar to yours.

Advanced out-of-the-box PTAB and TTAB analytics are always at your fingertips.

API

Docket Alarm offers a powerful API (application programming interface) to developers that want to integrate case filings into their apps.

LAW FIRMS

Build custom dashboards for your attorneys and clients with live data direct from the court.

Automate many repetitive legal tasks like conflict checks, document management, and marketing.

FINANCIAL INSTITUTIONS

Litigation and bankruptcy checks for companies and debtors.

E-DISCOVERY AND LEGAL VENDORS

Sync your system to PACER to automate legal marketing.