

AO 120 (Rev. 08/10)

TO: Mail Stop 8 Director of the U.S. Patent and Trademark Office P.O. Box 1450 Alexandria, VA 22313-1450	REPORT ON THE FILING OR DETERMINATION OF AN ACTION REGARDING A PATENT OR TRADEMARK
---	---

In Compliance with 35 U.S.C. § 290 and/or 15 U.S.C. § 1116 you are hereby advised that a court action has been filed in the U.S. District Court Western District of Texas on the following

Trademarks or Patents. (the patent action involves 35 U.S.C. § 292.);

DOCKET NO. 6:22-cv-00350	DATE FILED 4/1/2022	U.S. DISTRICT COURT Western District of Texas
PLAINTIFF ECOFACTOR, INC.		DEFENDANT GOOGLE LLC
PATENT OR TRADEMARK NO.	DATE OF PATENT OR TRADEMARK	HOLDER OF PATENT OR TRADEMARK
1 8,019,567	4/16/2013	EcoFactor, Inc.
2 10,612,983	3/6/2012	EcoFactor, Inc.
3 8,596,550	12/3/2013	EcoFactor, Inc.
4 8,886,488	7/10/2018	EcoFactor, Inc.
5		

In the above—entitled case, the following patent(s)/ trademark(s) have been included:

DATE INCLUDED	INCLUDED BY <input type="checkbox"/> Amendment <input type="checkbox"/> Answer <input type="checkbox"/> Cross Bill <input type="checkbox"/> Other Pleading	
PATENT OR TRADEMARK NO.	DATE OF PATENT OR TRADEMARK	HOLDER OF PATENT OR TRADEMARK
1		
2		
3		
4		
5		

In the above—entitled case, the following decision has been rendered or judgement issued:

DECISION/JUDGEMENT

CLERK	(BY) DEPUTY CLERK	DATE
-------	-------------------	------

Copy 1—Upon initiation of action, mail this copy to Director Copy 3—Upon termination of action, mail this copy to Director
Copy 2—Upon filing document adding patent(s), mail this copy to Director Copy 4—Case file copy



Best Available Copy

03-01-22 15:18

From-RUSS AUGUST, KABAT

USPTO RECEIVED RECEIVING DIVISION

+

T-963 P.01

F-086

701

RECEIVED CENTRAL FAX CENTER

2022 MAR -3 PM 2:33

MAR 01 2022

PTO/SB/66 (11-21)

Approved for use through 11/30/2024. OMB 0604-0016 U.S. Patent and Trademark Office, U.S. DEPARTMENT OF COMMERCE

Under the Paperwork Reduction Act of 1995, no persons are required to respond to a collection of information unless it displays a valid OMB control number.

PETITION TO ACCEPT UNINTENTIONALLY DELAYED PAYMENT OF MAINTENANCE FEE IN AN EXPIRED PATENT (37 CFR 1.378(b))		Docket Number (Optional) EFACT.007A
Page 1 of 4		
Mail to: Mail Stop Petition Commissioner for Patents P. O. Box 1450 Alexandria, VA 22313-1450 Fax: (571) 273-8300 NOTE: If information or assistance is needed in completing this form, please contact the Office of Petitions at (571) 272-3282		
Patent No. <u>8,596,550</u>	Application Number <u>12/778052</u>	
Issue Date <u>December 3, 2013</u>	Filing Date <u>May 11, 2010</u>	
CAUTION: Maintenance fee payment must correctly identify: (1) the patent number (or reissue patent number, if a reissue) and (2) the application number of the actual U.S. application (or reissue application) leading to issuance of that patent to ensure the fee(s) is/are associated with the correct patent. 37 CFR 1.366(c) and (d).		
Also complete the following information, if applicable: The above-identified patent <input type="checkbox"/> is a reissue of original Patent No. _____ original issue date _____ original application number _____ original filing date _____ <input type="checkbox"/> resulted from the entry into the U.S. under 35 U.S.C. 371 of international application _____ filed on _____		
NOTE: A grantable petition requires the following items: (1) Petition fee, (2) Maintenance fee, and (3) Statement that the delay in payment of the maintenance fee was unintentional		
CERTIFICATE OF MAILING OR TRANSMISSION (37 CFR 1.8(a))		
I hereby certify that this paper (* along with any paper referred to as being attached or enclosed) is being deposited with the United States Postal Service on the date shown below with sufficient postage as first class mail in an envelope addressed to Mail Stop Petition, Commissioner for Patents, P. O. Box 1450, Alexandria, VA 22313-1450, or being transmitted to the U.S. Patent and Trademark Office by EFS-Web, or by facsimile to (571) 273-8300, on the date shown below		
<u>March 1, 2022</u>	<u>/Alexandra Loew/</u>	
Date	Signature	
	<u>Alexandra Loew</u>	
	Typed or Printed Name of Person Signing Certificate	

(page 1 of 3)

A Federal agency may not conduct or sponsor, and a person is not required to respond to, nor shall a person be subject to a penalty for failure to comply with an information collection subject to the requirements of the Paperwork Reduction Act of 1995, unless the information collection has a currently valid OMB Control Number. The OMB Control Number for this information collection is 0651-0016. Public burden for this form is estimated to average 1 hour per response, including the time for reviewing instructions, searching existing data sources, gathering and maintaining the data needed, and completing and reviewing the information collection. Send comments regarding this burden estimate or any other aspect of this information collection, including suggestions for reducing this burden to the Chief Administrative Officer, United States Patent and Trademark Office, P. O. Box 1450, Alexandria, VA 22313-1450 or email informationCollection@uspto.gov. DO NOT SEND FEES OR COMPLETED FORMS TO THIS ADDRESS. SEND TO: Commissioner for Patents, P. O. Box 1450, Alexandria, VA 22313-1450.

If you need assistance in completing the form, call 1-800-PTO-9199 and select option 2.

PTO/SB/66 (11-21)

Approved for use through 11/30/2024 OMB Job#-0016

U.S. Patent and Trademark Office; U.S. DEPARTMENT OF COMMERCE

Under the Paperwork Reduction Act of 1995, no persons are required to respond to a collection of information unless it displays a valid OMB control number.

PETITION TO ACCEPT UNINTENTIONALLY DELAYED PAYMENT OF MAINTENANCE FEE IN AN EXPIRED PATENT (37 CFR 1.378(b))

Page 2 of 4

1. SMALL ENTITY

Patentee asserts, or has previously asserted, small entity status. See 37 CFR 1.27.

2. LOSS OF ENTITLEMENT TO SMALL ENTITY STATUS

Patentee is no longer entitled to small entity status. See 37 CFR 1.27(g).

3. MICRO ENTITY

Patentee certifies, or has previously certified, micro entity status. See 37 CFR 1.29. Form PTO/SB/15A or B or equivalent must either be enclosed or have been submitted previously.

4. LOSS OF ENTITLEMENT TO MICRO ENTITY STATUS

Patentee is no longer entitled to micro entity status. See 37 CFR 1.29(i).

5. MAINTENANCE FEE (37 CFR 1.20(e)-(g))

The appropriate maintenance fee must be submitted with this petition, unless it was paid earlier.

Undiscounted			Small Entity			Micro Entity		
Amount	Fee	(Code)	Amount	Fee	(Code)	Amount	Fee	(Code)
<input type="checkbox"/> \$ _____	3½ yr fee	(1551)	<input type="checkbox"/> \$ _____	3½ yr fee	(2551)	<input type="checkbox"/> \$ _____	3½ yr fee	(3551)
<input checked="" type="checkbox"/> \$ <u>3,760.00</u>	7½ yr fee	(1552)	<input type="checkbox"/> \$ _____	7½ yr fee	(2552)	<input type="checkbox"/> \$ _____	7½ yr fee	(3552)
<input type="checkbox"/> \$ _____	11½ yr fee	(1553)	<input type="checkbox"/> \$ _____	11½ yr fee	(2553)	<input type="checkbox"/> \$ _____	11½ yr fee	(3553)

MAINTENANCE FEE BEING SUBMITTED \$ 3,760.00

6. PETITION FEE

The petition fee required by 37 CFR 1.17(m) of:

\$ 2,100.00 Undiscounted (Fee Code 1558), or

\$ _____ Small Entity (Fee Code 2558); or

\$ _____ Micro Entity (Fee Code 3558)

must be paid as a condition of accepting an unintentionally delayed payment of a maintenance fee.

PETITION FEE BEING SUBMITTED \$ 2,100.00

7. MANNER OF PAYMENT

Enclosed is a check for the sum of \$ _____

Please charge Deposit Account No. _____, the sum of \$ _____

Payment by credit card. Form PTO-2038 is attached.

Payment made via EFS-Web

8. AUTHORIZATION TO CHARGE ANY FEE DEFICIENCY

The Director is hereby authorized to charge any maintenance fee or petition deficiency to Deposit Account No. _____

PTO/SB/66 (11-21)

Approved for use through 11/30/2024 OMB 0651-0016
U.S. Patent and Trademark Office, U.S. DEPARTMENT OF COMMERCE

Under the Paperwork Reduction Act of 1995, no persons are required to respond to a collection of information unless it displays a valid OMB control number.

**PETITION TO ACCEPT UNINTENTIONALLY DELAYED PAYMENT
OF MAINTENANCE FEE IN AN EXPIRED PATENT (37 CFR 1.378(b))**

Page 3 of 4

9. OVERPAYMENT

As to any overpayment made, please

Credit to Deposit account No. _____

OR

Send refund check

WARNING:

Petitioner/applicant is cautioned to avoid submitting personal information in documents filed in a patent application that may contribute to identity theft. Personal information, such as social security numbers, bank account numbers, or credit card numbers (other than a check or credit card authorization form (PTO-2038) submitted for payment purposes), is never required by the USPTO to support a petition or an application. If this type of personal information is included in documents submitted to the USPTO, petitioner/applicant should consider redacting such personal information from the documents before submitting them to the USPTO. Petitioner/applicant is advised that the record of a patent application is available to the public after publication of the application (unless a non-publication request in compliance with 37 CFR 1.213(a) is made in the application or issuance of a patent). Furthermore, the record from an abandonment application may also be available to the public if the application is referenced in a published application or an issued patent (see 37 CFR 1.14). Checks and credit card authorization forms (PTO-2038) submitted for payment purposes are not retained in the application file and therefore are not publicly available.

10. STATEMENT

The delay in payment of the maintenance fee for this patent was unintentional.

Petitioner is reminded that a delay resulting from a deliberately chosen course of action or a change in circumstance is not an unintentional delay.

Petitioner is further reminded that a person seeking reinstatement of an expired patent should not make a statement that the delay in payment of the maintenance fee was unintentional unless the entire delay was unintentional, including the period from discovery that the maintenance fee was not timely paid until payment of the maintenance fee. For example, a statement that the delay in payment of the maintenance fee was unintentional would not be proper when the patentee becomes aware of an unintentional failure to timely pay the maintenance fee and then intentionally delays filing a petition for reinstatement of the patent under 37 CFR 1.378. See MPEP 2530.

NOTE: Where the petition under 37 CFR 1.378 is filed more than two years after the date the patent expired for nonpayment of the maintenance fee, the United States Patent and Trademark Office requires an additional explanation of the circumstances surrounding the delay that establishes the entire delay was unintentional. This requirement is in addition to the requirement to provide a statement that the entire delay was unintentional. See *Clarification of the Practice for Requiring Additional Information in Petitions Filed in Patent Applications and Patents Based on Unintentional Delay*, 85 FR 12222 (March 2, 2020). See MPEP 711.03(c)(1)(C)-(F) for additional guidance on the information required to establish that the entire delay was unintentional.

Because this petition under 37 CFR 1.378 is being filed more than two years after the date the patent expired for nonpayment of the maintenance fee, additional explanation of the circumstances surrounding the delay that establishes the entire delay was unintentional is enclosed herewith.

Best Available Copy

03-01-22 15:19

From-RUSS AUGUST KABAT

+

T-963 P.04/11 F-086

PTO/58/66 (11-21)
Approved for use through 11/30/2024 OMB 0651-0016
U.S. Patent and Trademark Office, U.S. DEPARTMENT OF COMMERCE
under the Paperwork Reduction Act of 1995, no persons are required to respond to a collection of information unless it displays a valid OMB control number.

**PETITION TO ACCEPT UNINTENTIONALLY DELAYED PAYMENT
OF MAINTENANCE FEE IN AN EXPIRED PATENT (37 CFR 1.378(b))**

Page 4 of 4

11. PETITIONER REQUESTS THAT THE DELAYED PAYMENT OF THE MAINTENANCE FEE BE ACCEPTED AND THE PATENT BE REINSTATED.

March 1, 2022

Date

/Shayan Habib/

Signature(s) of Petitioner

Shayan Habib

Typed or Printed Name

Registration Number, if applicable

650-716-4760

Telephone Number

441 California Avenue, Number 2

Address

Palo Alto, California 94301

Address

37 CFR 1.378(c) states: "Any petition under this section must be signed in compliance with § 1.33(b)."

12. ENCLOSURES

- Maintenance Fee Payment
- Petition fee under 37 CFR 1.17(m) (fee for filing the maintenance fee petition)
- Additional sheet(s) containing statement establishing unintentional delay
- Other: _____

MAR 01 2022

PTO/AIA/98 (08-12)

Approved for use through 11/30/2020 OMB 0851-0031 U.S. Patent and Trademark Office, U.S. DEPARTMENT OF COMMERCE

Under the Paperwork Reduction Act of 1995, no persons are required to respond to a collection of information unless it displays a valid OMB control number.

STATEMENT UNDER 37 CFR 3.73(c)

Applicant/Patent Owner: EcoFactor, Inc.

Application No./Patent No.: 8 596,550 Filed/Issue Date: 12/3/2013

Titled: System, Method and Apparatus for Identifying Manual Inputs and Adaptive Programming of a Thermostat

EcoFactor, Inc. a US corporation

(Name of Assignee) (Type of Assignee, e.g., corporation, partnership, university, government agency, etc.)

states that, for the patent application/patent identified above, it is (choose one of options 1, 2, 3 or 4 below):

- 1. [x] The assignee of the entire right, title, and interest.
2. [] An assignee of less than the entire right, title, and interest (check applicable box):
[] The extent (by percentage) of its ownership interest is % Additional Statement(s) by the owners holding the balance of the interest must be submitted to account for 100% of the ownership interest
[] There are unspecified percentages of ownership. The other parties, including inventors, who together own the entire right, title and interest are

Additional Statement(s) by the owner(s) holding the balance of the interest must be submitted to account for the entire right, title, and interest

- 3. [] The assignee of an undivided interest in the entirety (a complete assignment from one of the joint inventors was made). The other parties, including inventors, who together own the entire right, title, and interest are

Additional Statement(s) by the owner(s) holding the balance of the interest must be submitted to account for the entire right, title, and interest.

- 4. [] The recipient, via a court proceeding or the like (e.g., bankruptcy, probate), of an undivided interest in the entirety (a complete transfer of ownership interest was made). The certified document(s) showing the transfer is attached

The interest identified in option 1, 2 or 3 above (not option 4) is evidenced by either (choose one of options A or B below)

- A. [x] An assignment from the inventor(s) of the patent application/patent identified above. The assignment was recorded in the United States Patent and Trademark Office at Reel 024907, Frame 0342 or for which a copy thereof is attached.

- B. [] A chain of title from the inventor(s), of the patent application/patent identified above, to the current assignee as follows:

1. From: To:

The document was recorded in the United States Patent and Trademark Office at Reel, Frame or for which a copy thereof is attached

2. From: To:

The document was recorded in the United States Patent and Trademark Office at Reel, Frame or for which a copy thereof is attached

[Page 1 of 2]

This collection of information is required by 37 CFR 3.73(b). The information is required to obtain or retain a benefit by the public which is to him (and by the USPTO to process) an application. Confidentiality is governed by 35 U.S.C. 122 and 37 CFR 1.11 and 1.14. This collection is estimated to take 12 minutes to complete, including gathering, preparing, and submitting the completed application form to the USPTO. Time will vary depending upon the individual case. Any comments on the amount of time you require to complete this form and/or suggestions for reducing this burden, should be sent to the Chief Information Officer, U.S. Patent and Trademark Office, U.S. Department of Commerce, P.O. Box 1450, Alexandria, VA 22313-1450. DO NOT SEND FEES OR COMPLETED FORMS TO THIS ADDRESS. SEND TO: Commissioner for Patents, P.O. Box 1450, Alexandria, VA 22313-1450.

If you need assistance in completing the form, call 1-800-PTO-9199 and select option 2.

Best Available Copy

03-01-22 15:20

From-RUSS AUGUST KABAT

+

T-863 P.07/11 F-086

PTO/AIA/96 (08-12)
Approved for use through 11/30/2020 OMB 0851-0031
U.S. Patent and Trademark Office, U.S. DEPARTMENT OF COMMERCE
Under the Paperwork Reduction Act of 1995, no persons are required to respond to a collection of information unless it displays a valid OMB control number.

STATEMENT UNDER 37 CFR 3.73(c)

3. From: _____ To: _____

The document was recorded in the United States Patent and Trademark Office at
Reel _____, Frame _____, or for which a copy thereof is attached

4. From: _____ To: _____

The document was recorded in the United States Patent and Trademark Office at
Reel _____, Frame _____, or for which a copy thereof is attached.

5. From: _____ To: _____

The document was recorded in the United States Patent and Trademark Office at
Reel _____, Frame _____, or for which a copy thereof is attached.

6. From: _____ To: _____

The document was recorded in the United States Patent and Trademark Office at
Reel _____, Frame _____, or for which a copy thereof is attached.

Additional documents in the chain of title are listed on a supplemental sheet(s).

As required by 37 CFR 3.73(c)(1)(i), the documentary evidence of the chain of title from the original owner to the assignee was, or concurrently is being, submitted for recordation pursuant to 37 CFR 3.11
[NOTE: A separate copy (i.e., a true copy of the original assignment document(s)) must be submitted to Assignment Division in accordance with 37 CFR Part 3, to record the assignment in the records of the USPTO. See MPEP 302.08]

The undersigned (whose title is supplied below) is authorized to act on behalf of the assignee

/Shayan Habib/

March 1, 2022

Signature

Date

Shayan Habib

CEO of EcoFactor, Inc

Printed or Typed Name

Title or Registration Number

AO 120 (Rev. 08/10)

TO: Mail Stop 8 Director of the U.S. Patent and Trademark Office P.O. Box 1450 Alexandria, VA 22313-1450	REPORT ON THE FILING OR DETERMINATION OF AN ACTION REGARDING A PATENT OR TRADEMARK
---	---

In Compliance with 35 U.S.C. § 290 and/or 15 U.S.C. § 1116 you are hereby advised that a court action has been filed in the U.S. District Court Delaware on the following
 Trademarks or Patents. (the patent action involves 35 U.S.C. § 292.):

DOCKET NO.	DATE FILED 3/3/2021	U.S. DISTRICT COURT Delaware
PLAINTIFF Carrier Global Corporation		DEFENDANT EcoFactor, Inc.
PATENT OR TRADEMARK NO.	DATE OF PATENT OR TRADEMARK	HOLDER OF PATENT OR TRADEMARK
1 8,423,322	4/16/2013	EcoFactor, Inc.
2 8,019,567	9/13/2011	EcoFactor, Inc.
3 10,612,983	4/7/2020	EcoFactor, Inc.
4 8,596,550	12/3/2013	EcoFactor, Inc.
5 8,886,488	11/11/2014	EcoFactor, Inc.

In the above—entitled case, the following patent(s)/ trademark(s) have been included:

DATE INCLUDED	INCLUDED BY <input type="checkbox"/> Amendment <input type="checkbox"/> Answer <input type="checkbox"/> Cross Bill <input type="checkbox"/> Other Pleading	
PATENT OR TRADEMARK NO.	DATE OF PATENT OR TRADEMARK	HOLDER OF PATENT OR TRADEMARK
1		
2		
3		
4		
5		

In the above—entitled case, the following decision has been rendered or judgement issued:

DECISION/JUDGEMENT

CLERK	(BY) DEPUTY CLERK	DATE
-------	-------------------	------

Copy 1—Upon initiation of action, mail this copy to Director Copy 3—Upon termination of action, mail this copy to Director
 Copy 2—Upon filing document adding patent(s), mail this copy to Director Copy 4—Case file copy

AO 120 (Rev. 08/10)

TO: Mail Stop 8 Director of the U.S. Patent and Trademark Office P.O. Box 1450 Alexandria, VA 22313-1450	REPORT ON THE FILING OR DETERMINATION OF AN ACTION REGARDING A PATENT OR TRADEMARK
---	--

In Compliance with 35 U.S.C. § 290 and/or 15 U.S.C. § 1116 you are hereby advised that a court action has been filed in the U.S. District Court _____ for the District of Delaware _____ on the following

Trademarks or Patents. (the patent action involves 35 U.S.C. § 292.);

DOCKET NO.	DATE FILED 3/1/2021	U.S. DISTRICT COURT for the District of Delaware
PLAINTIFF EMERSON ELECTRIC CO.		DEFENDANT ECOFACOR, INC.
PATENT OR TRADEMARK NO.	DATE OF PATENT OR TRADEMARK	HOLDER OF PATENT OR TRADEMARK
1 US 8,423,322 B2	4/16/2013	EcoFactor, Inc.
2 US 8,019,567 B2	9/13/2011	EcoFactor, Inc.
3 US 10,612,983 B2	4/7/2020	EcoFactor, Inc.
4 US 8,596,550 B2	12/3/2013	EcoFactor, Inc.
5 US 8,886,488 B2	11/11/2014	EcoFactor, Inc.

In the above—entitled case, the following patent(s)/ trademark(s) have been included:

DATE INCLUDED	INCLUDED BY <input type="checkbox"/> Amendment <input type="checkbox"/> Answer <input type="checkbox"/> Cross Bill <input type="checkbox"/> Other Pleading	
PATENT OR TRADEMARK NO.	DATE OF PATENT OR TRADEMARK	HOLDER OF PATENT OR TRADEMARK
1		
2		
3		
4		
5		

In the above—entitled case, the following decision has been rendered or judgement issued:

DECISION/JUDGEMENT

CLERK	(BY) DEPUTY CLERK	DATE
-------	-------------------	------

Copy 1—Upon initiation of action, mail this copy to Director Copy 3—Upon termination of action, mail this copy to Director
 Copy 2—Upon filing document adding patent(s), mail this copy to Director Copy 4—Case file copy

AO 120 (Rev. 08/10)

TO: Mail Stop 8 Director of the U.S. Patent and Trademark Office P.O. Box 1450 Alexandria, VA 22313-1450	REPORT ON THE FILING OR DETERMINATION OF AN ACTION REGARDING A PATENT OR TRADEMARK
---	---

In Compliance with 35 U.S.C. § 290 and/or 15 U.S.C. § 1116 you are hereby advised that a court action has been filed in the U.S. District Court _____ for the District of Delaware _____ on the following

Trademarks or Patents. (the patent action involves 35 U.S.C. § 292.);

DOCKET NO.	DATE FILED 3/1/2021	U.S. DISTRICT COURT for the District of Delaware
PLAINTIFF EMERSON ELECTRIC CO.		DEFENDANT ECOFACTOR, INC.
PATENT OR TRADEMARK NO.	DATE OF PATENT OR TRADEMARK	HOLDER OF PATENT OR TRADEMARK
1 US 8,423,322 B2	4/16/2013	EcoFactor, Inc.
2 US 8,019,567 B2	9/13/2011	EcoFactor, Inc.
3 US 10,612,983 B2	4/7/2020	EcoFactor, Inc.
4 US 8,596,550 B2	12/3/2013	EcoFactor, Inc.
5 US 8,886,488 B2	11/11/2014	EcoFactor, Inc.

In the above—entitled case, the following patent(s)/ trademark(s) have been included:

DATE INCLUDED	INCLUDED BY <input type="checkbox"/> Amendment <input type="checkbox"/> Answer <input type="checkbox"/> Cross Bill <input type="checkbox"/> Other Pleading	
PATENT OR TRADEMARK NO.	DATE OF PATENT OR TRADEMARK	HOLDER OF PATENT OR TRADEMARK
1		
2		
3		
4		
5		

In the above—entitled case, the following decision has been rendered or judgement issued:

DECISION/JUDGEMENT Dismissed - see attached
--

CLERK John A. Cerino	(BY) DEPUTY CLERK /s/ Mark D. Buckson, Jr.	DATE 4/19/2021
-------------------------	---	-------------------

Copy 1—Upon initiation of action, mail this copy to Director Copy 3—Upon termination of action, mail this copy to Director
Copy 2—Upon filing document adding patent(s), mail this copy to Director Copy 4—Case file copy



UNITED STATES PATENT AND TRADEMARK OFFICE

UNITED STATES DEPARTMENT OF COMMERCE
United States Patent and Trademark Office
Address: COMMISSIONER FOR PATENTS
P.O. Box 1450
Alexandria, Virginia 22313-1450
www.uspto.gov

Table with 5 columns: APPLICATION NO., ISSUE DATE, PATENT NO., ATTORNEY DOCKET NO., CONFIRMATION NO.
12/778.052, 12/03/2013, 8596550, EFACT.007A, 5650

20995 7590 11/13/2013
KNOBBE MARTENS OLSON & BEAR LLP
2040 MAIN STREET
FOURTEENTH FLOOR
IRVINE, CA 92614

ISSUE NOTIFICATION

The projected patent number and issue date are specified above.

Determination of Patent Term Adjustment under 35 U.S.C. 154 (b)
(application filed on or after May 29, 2000)

The Patent Term Adjustment is 866 day(s). Any patent to issue from the above-identified application will include an indication of the adjustment on the front page.

If a Continued Prosecution Application (CPA) was filed in the above-identified application, the filing date that determines Patent Term Adjustment is the filing date of the most recent CPA.

Applicant will be able to obtain more detailed information by accessing the Patent Application Information Retrieval (PAIR) WEB site (http://pair.uspto.gov).

Any questions regarding the Patent Term Extension or Adjustment determination should be directed to the Office of Patent Legal Administration at (571)-272-7702. Questions relating to issue and publication fee payments should be directed to the Application Assistance Unit (AAU) of the Office of Data Management (ODM) at (571)-272-4200.

APPLICANT(s) (Please see PAIR WEB site http://pair.uspto.gov for additional applicants):

John Douglas Steinberg, Millbrae, CA;
Scott Douglas Hublou, Redwood City, CA;
Leo Cheung, Sunnyvale, CA;

The United States represents the largest, most dynamic marketplace in the world and is an unparalleled location for business investment, innovation, and commercialization of new technologies. The USA offers tremendous resources and advantages for those who invest and manufacture goods here. Through SelectUSA, our nation works to encourage and facilitate business investment. To learn more about why the USA is the best country in the world to develop technology, manufacture products, and grow your business, visit SelectUSA.gov.

date received: 7/12/13 /MN/

PTO/SB/08 Equivalent

INFORMATION DISCLOSURE STATEMENT BY APPLICANT	Application No.	12/778,052	
	Filing Date	May 11, 2010	
	First Named Inventor	John Douglas Steinberg	
	Art Unit	3744	
<i>(Multiple sheets used when necessary)</i>		Examiner	Norman, Marc E.
SHEET 1 OF 2		Attorney Docket No.	EFACT.007A

U.S. PATENT DOCUMENTS

Examiner Initials	Cite No.	Document Number Number - Kind Code (if known) Example: 1,234,567 B1	Publication Date MM-DD-YYYY	Name of Patentee or Applicant	Pages, Columns, Lines Where Relevant Passages or Relevant Figures Appear
	1	6,400,956	06-02-2002	Richton	
	2	8,457,797	06-04-2013	Imes, et al.	
	3	2010/0289643	11-18-2010	Trundle, et al.	
	4	2011/0046792	02-24-2011	Imes, et al.	
	5	2011/0046798	02-24-2011	Imes, et al.	
	6	2011/0046799	02-24-2011	Imes, et al.	
	7	2011/0046800	02-24-2011	Imes, et al.	
	8	2011/0046801	02-24-2011	Imes, et al.	
	9	2011/0051823	03-03-2011	Imes, et al.	
	10	2011/0054699	03-03-2011	Imes, et al.	
	11	2011/0054710	03-03-2011	Imes, et al.	
	12	2011/0173542	07-14-2011	Imes, et al.	
	13	2011/0202185	08-18-2011	Imes, et al.	
	14	2011/0214060	09-09-2011	Imes, et al.	
	15	2011/0224838	09-15-2011	Imes, et al.	
	16	2011/0246898	10-06-2011	Imes, et al.	
	17	2011/0307101	12-15-2011	Imes, et al.	
	18	2012/0023225	01-26-2012	Imes, et al.	
	19	2012/0046859	02-23-2012	Imes, et al.	
	20	2012/0064923	03-15-2012	Imes, et al.	
	21	2012/0072033	03-22-2012	Imes, et al.	
	22	2012/0093141	04-19-2012	Imes, et al.	
	23	2012/0101637	04-26-2012	Imes, et al.	
	24	2012/0135759	05-31-2012	Imes, et al.	
	25	2012/0215725	08-23-2012	Imes, et al.	
	26	2012/0221718	08-30-2012	Imes, et al.	
	27	2012/0252430	10-04-2012	Imes, et al.	
	28	2012/0324119	12-20-2012	Imes, et al.	
	29	2013/0053054	02-28-2013	Lovitt, et al.	

Change(s) applied
to document,
/A.E.M./
10/30/2013

Examiner Signature	Date Considered
*Examiner: Initial if reference considered, whether or not citation is in conformance with MPEP 609. Draw line through citation if not in conformance and not considered. Include copy of this form with next communication to applicant.	

T¹ - Place a check mark in this area when an English language Translation is attached.

ALL REFERENCES CONSIDERED EXCEPT WHERE LINED THROUGH. /MN/

INFORMATION DISCLOSURE STATEMENT BY APPLICANT	Application No.	Unknown
	Filing Date	Herewith
	First Named Inventor	Steinberg, John Douglas et al
	Art Unit	
<i>(Multiple sheets used when necessary)</i>		Examiner
SHEET 2 OF 4		Attorney Docket No. EFACT.007A

U.S. PATENT DOCUMENTS					
Examiner Initials	Cite No.	Document Number Number - Kind Code (if known) Example: 1,234,567 B1	Publication Date MM-DD-YYYY	Name of Patentee or Applicant	Pages, Columns, Lines Where Relevant Passages or Relevant Figures Appear
	30	6,695,218	02-24-2004	Fleckenstein	
	31	6,726,113	04-27-2004	Guo	
	32	6,731,992	05-04-2004	Ziegler	
	33	6,734,806	05-11-2004	Cratsley	
	34	6,772,052	08-03-2004	Amundsen	
	35	6,785,592	08-31-2004	Smith	
	36	6,785,630	08-31-2004	Kolk	
	37	6,789,739	09-14-2004	Rosen	
	38	6,853,959	02-08-2005	Ikeda, et al.	
	39	6,868,293	03-15-2005	Schurr	
	40	6,868,319	03-15-2005	Kipersztok, et al.	
	41	6,882,712	04-19-2005	Iggulden, et al.	
	42	6,889,908	05-10-2005	Crippen, et al.	
	43	6,891,838	05-10-2005	Petite, et al.	
	44	6,991,029	01-31-2006	Orfield, et al.	
	45	7,009,493	03-07-2006	Howard	
	46	7,031,880	04-18-2006	Seem, et al.	
	47	7,039,532	05-02-2006	Hunter	
	48	7,089,088	08-08-2006	Terry, et al.	
	49	7,130,719	10-31-2006	Ehlers, et al.	
	50	7,130,832	10-31-2006	Bannai, et al.	
	51	7,167,079	01-23-2007	Smyth, et al.	
	52	7,187,986	03-06-2007	Johnson, et al.	
	53	7,205,892	04-17-2007	Luebke, et al.	
	54	7,215,746	05-08-2007	Iggulden, et al.	
	55	7,216,015	05-08-2007	Poth, Robert J.	
	56	7,231,424	06-11-2007	Bodin, et al.	
	57	7,232,075	06-19-2007	Rosen	
	58	2003/0040934 A1	02-27-2003	Skidmore, et al.	

Change(s) applied
to document,
/A.E.M./
10/30/2013

Examiner Signature /Marc Norman/	Date Considered 04/16/2013
*Examiner: Initial if reference considered, whether or not citation is in conformance with MPEP 609. Draw line through citation if not in conformance and not considered. Include copy of this form with next communication to applicant.	

T¹ - Place a check mark in this area when an English language translation is attached. **ALL REFERENCES CONSIDERED EXCEPT WHERE LINED THROUGH. /MN/**

Date received: 5/11/10

/MN/

PTO/SB/08 Equivalent

INFORMATION DISCLOSURE STATEMENT BY APPLICANT	Application No.	Unknown
	Filing Date	Herewith
	First Named Inventor	Steinberg, John Douglas et al
	Art Unit	
<i>(Multiple sheets used when necessary)</i>		Examiner
SHEET 1 OF 4		Attorney Docket No. EFACT.007A

Change (Initials) applied to document, /A.E.M./ 10/30/2013

U.S. PATENT DOCUMENTS					
Examiner (Initials)	Cite No.	Document Number Number - Kind Code (if known) Example: 1,234,567 B1	Publication Date MM-DD-YYYY	Name of Patentee or Applicant	Pages, Columns, Lines Where Relevant Passages or Relevant Figures Appear
	1	4,403,644	09-13-1983	Raymond T. Hebert	
	2	4,674,027	06-16-1987	Beckey	
	3	5,572,438	11-05-1996	Ehlers, et al.	
	4	5,717,609	02-10-1998	Packa, et al.	
	5	6,145,751	11-14-2000	Ahmed	
	6	6,178,362	01-23-2001	Woolard, et al.	
	7	6,351,693	02-26-2002	Monie	
	8	6,400,996	06-04-2002	Hoffberg, et al.	
	9	6,437,692	08-20-2002	Petite, et al.	
	10	6,478,233	11-12-2002	Shah	
	11	6,480,803	11-12-2002	Pierret, et al.	
	12	6,483,906	11-19-2002	Lggulden, et al.	
	13	6,536,675	03-25-2003	Pesko, et al.	
	14	6,542,076	04-01-2003	Joao	
	15	6,549,130	04-15-2003	Joao	
	16	6,574,537	06-02-2003	Kipersztok, et al.	
	17	6,580,950	06-17-2003	Johnson	
	18	6,594,825	07-15-2003	Goldschmidtli, et al.	
	19	6,595,430	07-22-2003	Shah	
	20	6,598,056	07-22-2003	Hull, et al.	
	21	6,619,555	09-16-2003	Rosen	
	22	6,622,097	09-16-2003	Hunter	
	23	6,622,115	09-16-2003	Brown, et al.	
	24	6,622,925	09-23-2003	Carner, et al.	
	25	6,622,926	09-23-2003	Sartain, et al.	
	26	6,628,997	09-30-2003	Fox, et al.	
	27	6,633,823	10-14-2003	Bartone, et al.	
	28	6,643,567	11-04-2003	Kolk et al.	
	29	6,671,586	12-30-2003	Davis, et al.	

Examiner Signature	/Marc Norman/	Date Considered	04/16/2013
<p>*Examiner: Initial if reference considered, whether or not citation is in conformance with MPEP 609. Draw line through citation if not in conformance and not considered. Include copy of this form with next communication to applicant.</p>			

T¹ - Place a check mark in this area when an English language translation is attached. **ALL REFERENCES CONSIDERED EXCEPT WHERE LINED THROUGH.** /MN/



UNITED STATES PATENT AND TRADEMARK OFFICE

UNITED STATES DEPARTMENT OF COMMERCE
United States Patent and Trademark Office
Address: COMMISSIONER FOR PATENTS
P.O. Box 1450
Alexandria, Virginia 22313-1450
www.uspto.gov

Table with 5 columns: APPLICATION NO., FILING DATE, FIRST NAMED INVENTOR, ATTORNEY DOCKET NO., CONFIRMATION NO.
Row 1: 12/778,052, 05/11/2010, John Douglas Steinberg, EFACT.007A, 5650
Row 2: 7590, 11/05/2013, KNOBBE MARTENS OLSON & BEAR LLP, 2040 MAIN STREET, FOURTEENTH FLOOR, IRVINE, CA 92614, EXAMINER NORMAN, MARC E
Row 3: ART UNIT 3744, PAPER NUMBER
Row 4: NOTIFICATION DATE 11/05/2013, DELIVERY MODE ELECTRONIC

NOTICE OF NON-COMPLIANT INFORMATION DISCLOSURE STATEMENT

An Information Disclosure Statement (IDS) filed 10-30-13 in the above-identified application fails to meet the requirements of 37 CFR 1.97(d) for the reason(s) specified below. Accordingly, the IDS will be placed in the file, but the information referred to therein has not been considered.

The IDS is not compliant with 37 CFR 1.97(d) because:

- [X] The IDS lacks a statement as specified in 37 CFR 1.97(e).
[] The IDS lacks the fee set forth in 37 CFR 1.17(p).
[] The IDS was filed after the issue fee was paid. Applicant may wish to consider filing a petition to withdraw the application from issue under 37 CFR 1.313(c) to have the IDS considered. See MPEP 1308.

Handwritten signature of P. A. S.

571-272-4200 or 1-888-786-0101
Application Assistance Unit
Office of Data Management



UNITED STATES PATENT AND TRADEMARK OFFICE

UNITED STATES DEPARTMENT OF COMMERCE
United States Patent and Trademark Office
Address: COMMISSIONER FOR PATENTS
P.O. Box 1450
Alexandria, Virginia 22313-1450
www.uspto.gov

APPLICATION NO.	FILING DATE	FIRST NAMED INVENTOR	ATTORNEY DOCKET NO.	CONFIRMATION NO.
12/778,052	05/11/2010	John Douglas Steinberg	EFACT.007A	5650

20995 7590 11/04/2013
KNOBBE MARTENS OLSON & BEAR LLP
2040 MAIN STREET
FOURTEENTH FLOOR
IRVINE, CA 92614

EXAMINER	
NORMAN, MARC E	

ART UNIT	PAPER NUMBER
3744	

NOTIFICATION DATE	DELIVERY MODE
11/04/2013	ELECTRONIC

Please find below and/or attached an Office communication concerning this application or proceeding.

The time period for reply, if any, is set in the attached communication.

Notice of the Office communication was sent electronically on above-indicated "Notification Date" to the following e-mail address(es):

jayna.cartee@knobbe.com
efiling@knobbe.com

Response to Rule 312 Communication	Application No. 12778052	Applicant(s) John Douglas Steinberg
	Examiner	Art Unit

-- The MAILING DATE of this communication appears on the cover sheet with the correspondence address --

1. The amendment filed on 30 October 2013 under 37 CFR 1.312 has been considered, and has been:
- a) entered.
 - b) entered as directed to matters of form not affecting the scope of the invention.
 - c) disapproved because the amendment was filed after the payment of the issue fee.
Any amendment filed after the date the issue fee is paid must be accompanied by a petition under 37 CFR 1.313(c)(1) and the required fee to withdraw the application from issue.
 - d) disapproved. See explanation below.
 - e) entered in part. See explanation below.

/ Timothy Caldwell /

Publishing Division

PART B - FEE(S) TRANSMITTAL

Complete and send this form, together with applicable fee(s), to: **Mail** Mail Stop ISSUE FEE
Commissioner for Patents
P.O. Box 1450
Alexandria, Virginia 22313-1450
 or **Fax** (571)-273-2885

INSTRUCTIONS: This form should be used for transmitting the ISSUE FEE and PUBLICATION FEE (if required). Blocks 1 through 5 should be completed where appropriate. All further correspondence including the Patent, advance orders and notification of maintenance fees will be mailed to the current correspondence address as indicated unless corrected below or directed otherwise in Block 1, by (a) specifying a new correspondence address; and/or (b) indicating a separate "FEE ADDRESS" for maintenance fee notifications.

CURRENT CORRESPONDENCE ADDRESS (Note: Use Block 1 for any change of address)

20995 7590 07/31/2013
KNOBBE MARTENS OLSON & BEAR LLP
 2040 MAIN STREET
 FOURTEENTH FLOOR
 IRVINE, CA 92614

Note: A certificate of mailing can only be used for domestic mailings of the Fee(s) Transmittal. This certificate cannot be used for any other accompanying papers. Each additional paper, such as an assignment or formal drawing, must have its own certificate of mailing or transmission.

Certificate of Mailing or Transmission

I hereby certify that this Fee(s) Transmittal is being deposited with the United States Postal Service with sufficient postage for first class mail in an envelope addressed to the Mail Stop ISSUE FEE address above, or being facsimile transmitted to the USPTO (571) 273-2885, on the date indicated below.

_____ (Depositor's name)
_____ (Signature)
_____ (Date)

APPLICATION NO.	FILING DATE	FIRST NAMED INVENTOR	ATTORNEY DOCKET NO.	CONFIRMATION NO.
12/778,052	05/11/2010	John Douglas Steinberg	EFACT.007A	5650

TITLE OF INVENTION: SYSTEM, METHOD AND APPARATUS FOR IDENTIFYING MANUAL INPUTS TO AND ADAPTIVE PROGRAMMING OF A THERMOSTAT

APPLN. TYPE	ENTITY STATUS	ISSUE FEE DUE	PUBLICATION FEE DUE	PREV. PAID ISSUE FEE	TOTAL FEE(S) DUE	DATE DUE
nonprovisional	SMALL	\$890	\$300	\$0	\$1190	10/31/2013

EXAMINER	ART UNIT	CLASS-SUBCLASS
NORMAN, MARC E	3744	236-051000

1. Change of correspondence address or indication of "Fee Address" (37 CFR 1.363).
 Change of correspondence address (or Change of Correspondence Address form PTO/SB/122) attached.
 "Fee Address" indication (or "Fee Address" Indication form PTO/SB/47; Rev 03-02 or more recent) attached. Use of a Customer Number is required.

2. For printing on the patent front page, list
 (1) the names of up to 3 registered patent attorneys or agents OR, alternatively,
 (2) the name of a single firm (having as a member a registered attorney or agent) and the names of up to 2 registered patent attorneys or agents. If no name is listed, no name will be printed.

1. Knobbe, Martens,
 2. Olson & Bear, LLP
 3. _____

3. ASSIGNEE NAME AND RESIDENCE DATA TO BE PRINTED ON THE PATENT (print or type)

PLEASE NOTE: Unless an assignee is identified below, no assignee data will appear on the patent. If an assignee is identified below, the document has been filed for recordation as set forth in 37 CFR 3.11. Completion of this form is NOT a substitute for filing an assignment.

(A) NAME OF ASSIGNEE

(B) RESIDENCE: (CITY and STATE OR COUNTRY)

EcoFactor, Inc.

Millbrae, CA

Please check the appropriate assignee category or categories (will not be printed on the patent): Individual Corporation or other private group entity Government

4a. The following fee(s) are submitted:

- Issue Fee
- Publication Fee (No small entity discount permitted)
- Advance Order - # of Copies _____

4b. Payment of Fee(s): (Please first reapply any previously paid issue fee shown above)

- A check is enclosed.
- Payment by credit card. Form PTO-2038 is attached.
- The Director is hereby authorized to charge the required fee(s), any deficiency, or credit any overpayment, to Deposit Account Number 11-1410 (enclose an extra copy of this form).

5. **Change in Entity Status** (from status indicated above)

- Applicant certifying micro entity status. See 37 CFR 1.29
- Applicant asserting small entity status. See 37 CFR 1.27
- Applicant changing to regular undiscounted fee status.

NOTE: Absent a valid certification of Micro Entity Status (see form PTO/SB/15A and 15B), issue fee payment in the micro entity amount will not be accepted at the risk of application abandonment.

NOTE: If the application was previously under micro entity status, checking this box will be taken to be a notification of loss of entitlement to micro entity status.

NOTE: Checking this box will be taken to be a notification of loss of entitlement to small or micro entity status, as applicable.

NOTE: The Issue Fee and Publication Fee (if required) will not be accepted from anyone other than the applicant; a registered attorney or agent; or the assignee or other party in interest as shown by the records of the United States Patent and Trademark Office.

Authorized Signature John R. King
Typed or printed name John R. King

Date 10-30-2013
Registration No. 34,362

This collection of information is required by 37 CFR 1.311. The information is required to obtain or retain a benefit by the public which is to file (and by the USPTO to process) an application. Confidentiality is governed by 35 U.S.C. 122 and 37 CFR 1.14. This collection is estimated to take 12 minutes to complete, including gathering, preparing, and submitting the completed application form to the USPTO. Time will vary depending upon the individual case. Any comments on the amount of time you require to complete this form and/or suggestions for reducing this burden, should be sent to the Chief Information Officer, U.S. Patent and Trademark Office, U.S. Department of Commerce, P.O. Box 1450, Alexandria, Virginia 22313-1450. DO NOT SEND FEES OR COMPLETED FORMS TO THIS ADDRESS. SEND TO: Commissioner for Patents, P.O. Box 1450, Alexandria, Virginia 22313-1450.

Under the Paperwork Reduction Act of 1995, no persons are required to respond to a collection of information unless it displays a valid OMB control number.

IN THE UNITED STATES PATENT AND TRADEMARK OFFICE

Applicant	: Steinberg, et al.
Appl. No.	: 12/778,052
Filed	: May 11, 2010
For	: SYSTEM, METHOD AND APPARATUS FOR IDENTIFYING MANUAL INPUTS TO AND ADAPTIVE PROGRAMMING OF A THERMOSTAT
Examiner	: Marc E. Norman
Group Art Unit	: 3744

COMMENTS ON STATEMENT OF REASONS FOR ALLOWANCE

Commissioner for Patents
P.O. Box 1450
Alexandria, VA 22313-1450

Dear Sir:

In response to the Statement of Reasons for Allowance in the Notice of Allowance mailed July 31, 2013, Applicant respectfully submits the following comments.

Applicant respectfully disagrees with the Examiner's statement of reasons for allowance to the extent that the limitations recited by the Examiner are not present in all of the claims. Also, to the extent that there is any implication that the patentability of the claims rests on the recitation of a single feature, Applicant respectfully disagrees with the Examiner's Statement because it is the combination of features that makes the claims patentable.

Applicant submits that the claims of the present application are allowable because each of the claims recites a combination of features that are not taught or suggested by the prior art.

Respectfully submitted,

KNOBBE, MARTENS, OLSON & BEAR, LLP

Dated: 10-30-2013

By: John R. King
John R. King
Registration No. 34,362
Attorney of Record
Customer No. 20,995
(949) 760-0404

INFORMATION DISCLOSURE STATEMENT

Inventor : John Douglas Steinberg, et al.
App. No. : 12/778052
Filed : May 11, 2010
For : SYSTEM, METHOD AND APPARATUS FOR
IDENTIFYING MANUAL INPUTS TO AND
ADAPTIVE PROGRAMMING OF A THERMOSTAT
Examiner : Norman, Marc E.
Art Unit : 3744
Conf. No. : 5650

Commissioner for Patents
P.O. Box 1450
Alexandria, VA 22313-1450

References and Listing

Submitted herewith in the above-identified application is an Information Disclosure Statement listing references for consideration. Copies of any listed foreign and non-patent literature references are being submitted.

Timing of Disclosure

This Information Disclosure Statement is being filed after the mailing date of a final action or after the mailing date of a Notice of Allowance. Please place these references in the file in accordance with 37 CFR 1.97(i).

Respectfully submitted,
KNOBBE, MARTENS, OLSON & BEAR, LLP

Dated: October 30, 2013

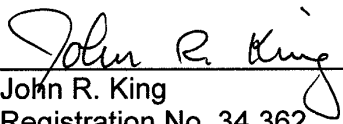
By: 
John R. King
Registration No. 34,362
Attorney of Record
Customer No. 20995
(949) 760-0404

INFORMATION DISCLOSURE STATEMENT BY APPLICANT	Application No.	12/778052	
	Filing Date	May 11, 2010	
	First Named Inventor	John Douglas Steinberg, et al.	
	Art Unit	3744	
<i>(Multiple sheets used when necessary)</i>		Examiner	Norman, Marc E.
SHEET 1 OF 1		Attorney Docket No.	EFACT.007A

U.S. PATENT DOCUMENTS					
Examiner Initials	Cite No.	Document Number Number - Kind Code (if known) Example: 1,234,567 B1	Publication Date MM-DD-YYYY	Name of Patentee or Applicant	Pages, Columns, Lines Where Relevant Passages or Relevant Figures Appear
	1	13/858710	09/05/2013	Steinberg et al.	
	2	6,786,421	09/07/2004	Rosen	
	3	2012/0221151 (EFACT.011C1)	08/30/2012	Steinberg	
	4	2013/0144445 (EFACT.013C2)	06/06/2013	Steinberg	

FOREIGN PATENT DOCUMENTS						
Examiner Initials	Cite No.	Foreign Patent Document Country Code-Number-Kind Code Example: JP 1234567 A1	Publication Date MM-DD-YYYY	Name of Patentee or Applicant	Pages, Columns, Lines Where Relevant Passages or Relevant Figures Appear	T ¹
	5	JP 05-189659	07/30/1993	Hitachi Bill Shisetsu Eng. KK.		
	6	JP 2010-038377	02/18/2010	Mitsubishi Heavy Ind. Ltd.		
	7	JP 2010-286218	12/24/2010	Mitsubishi Heavy Ind. Ltd.		
	8	KR 10-1999-0070368	09/15/1999	Samsung Electronics Co. Ltd.		
	9	WO 2011/149600 (EFACT.012WO)	12/01/2011	EcoFactor, Inc.		
	10	WO 2012/024534 (EFACT.013WO)	02/23/2012	EcoFactor, Inc.		

NON PATENT LITERATURE DOCUMENTS			
Examiner Initials	Cite No.	Include name of the author (in CAPITAL LETTERS), title of the article (when appropriate), title of the item (book, magazine, journal, serial, symposium, catalog, etc.), date, page(s), volume-issue number(s), publisher, city and/or country where published.	T ¹
	11	International Search Report and Written Opinion for PCT/US2013/035726 (EFACT.014WO), dated 8/6/13.	

16570834
103013

Examiner Signature	Date Considered
*Examiner: Initial if reference considered, whether or not citation is in conformance with MPEP 609. Draw line through citation if not in conformance and not considered. Include copy of this form with next communication to applicant.	

T¹ - Place a check mark in this area when an English language Translation is attached.

**Espacenet****Bibliographic data: JPH05189659 (A) — 1993-07-30****METHOD AND DEVICE FOR CALCULATING RATE OF CENTRAL AIR-CONDITIONING DEVICE**

No documents available for this priority number.

Inventor(s): SEKIGUCHI KYOICHI; KABETA AKIRA ± (SEKIGUCHI KYOICHI, ; KABETA AKIRA)**Applicant(s):** HITACHI BILL SHISETSU ENG KK ± (HITACHI BILL SHISETSU ENG KK)**Classification:** - international: **F24F5/00; G07F15/08**; (IPC1-7): F24F5/00; G07F15/08

- cooperative:

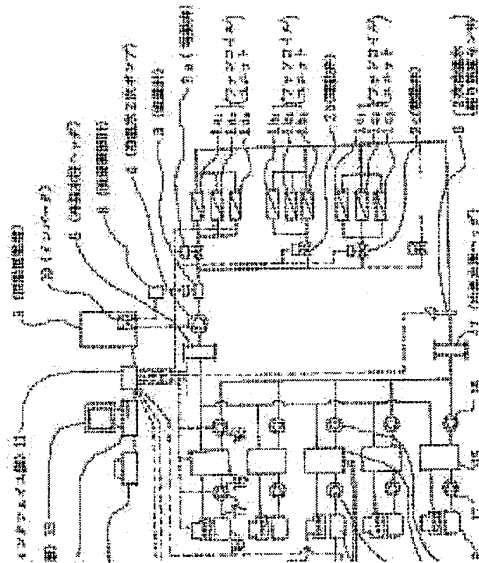
Application number: JP19920003090 19920110**Priority number (s):** JP19920003090 19920110**Also published as:** JPH071511 (B2)**Abstract of JPH05189659 (A)**

PURPOSE: To provide automatic rate calculating method and device capable of optionally operating individual load side apparatuses (e.g. fan coil units) by improving a central air-conditioning equipment utilizing an absorption type water cooling/heating machine having inexpensive energy cost. **CONSTITUTION:** Plural fan coil units (1a to 1a3) having the same or similar load pattern (a load rate and a load time band) are operated as one piping system and monitored and controlled by a computer 12 through a motor-operated valve 2a, the working electric energy, gas flow rate and consumed amount of water of respective apparatuses constituting the air-conditioning equipment are detected and inputted to the computer, running cost is calculated and the quantity of energy used by respective load side apparatuses is calculated, and the running cost is proportionally distributed in accordance with the quantity of used energy.

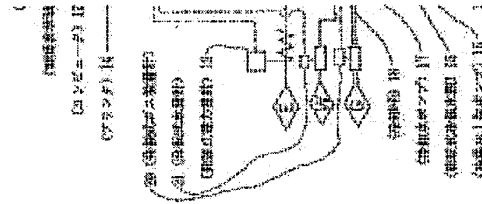

Last updated: 09.10.2013 Worldwide Database 5.8.11.5; 93p

(19)日本国特許庁 (J P)

(12) 公開特許公報 (A)

(11)特許出願公開番号

特開平5-189659

(43)公開日 平成5年(1993)7月30日

(51)Int.Cl. ⁵	識別記号	庁内整理番号	F I	技術表示箇所
G 0 7 F 15/08	1 0 2	9028-3E		
F 2 4 F 5/00	1 0 1 Z	6803-3L		

審査請求 有 請求項の数3(全7頁)

(21)出願番号 特願平4-3090

(22)出願日 平成4年(1992)1月10日

(71)出願人 391048050

日立ビル施設エンジニアリング株式会社
東京都千代田区神田和泉町1番地

(72)発明者 関口 恭一

東京都足立区中川四丁目16番29号 日立ビル施設エンジニアリング株式会社日立ビルシステム研究センター内

(72)発明者 壁田 昭

東京都千代田区神田和泉町1番地 日立ビル施設エンジニアリング株式会社内

(74)代理人 弁理士 秋本 正実

(54)【発明の名称】 セントラル冷暖房装置の料金算出方法および同料金算出装置

(57)【要約】

【目的】 エネルギーコストの安い吸収式冷温水機を用いたセントラル冷暖房設備を改良して、個々の負荷側機器(例えばファンコイルユニット)を任意に操作し得る、自動的料金計算方法、および同装置を提供する。

【構成】 負荷パターン(負荷率および負荷時間帯)が同様なし類似のファンコイルユニット(1 a₁, 1 a₂, 1 a₃)を一つの配管系とし、電動弁2 aを介してコンピュータ12によって監視、制御するとともに、冷暖房設備を構成している各機器の使用電力量、ガス流量、水道水量を検出して上記コンピュータに入力してランニングコストを算出し、かつ、各負荷側機器が利用したエネルギー量を算出し、ランニングコストを利用エネルギー量によって比例配分する。

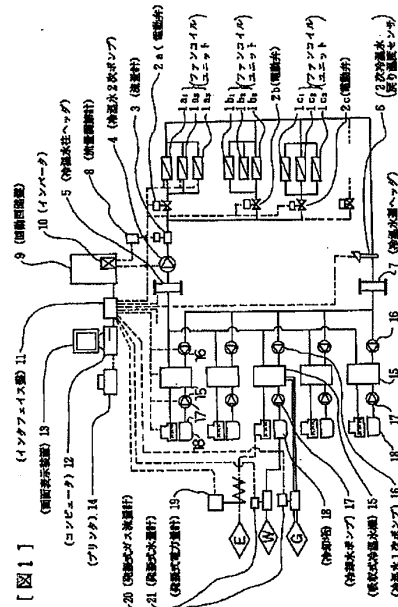

【特許請求の範囲】

【請求項1】 グループ毎に区分した多数の負荷側機器をグループ毎に接続した複数の配管系と、上記複数の配管系のそれぞれに設けられた電動弁と、上記多数の負荷側機器に冷温水を供給する複数の吸収式冷温水機およびその補機よりなる機器と、以上に述べた各機器の運転戻り信号を入力されるとともに、該各機器に対して運転指令信号を出力するセントラル冷暖房装置の料金を算定する方法であって、前記の各機器が消費した電力をコンピュータに入力して金額に換算し、同じく、消費した水道水量を前記のコンピュータに入力して金額に換算し、同じく、消費した燃料ガス量を前記のコンピュータに入力して金額に換算し、前記各機器に要した付帯経費を前記のコンピュータに入力し、上記の入力値に基づいて、前記のコンピュータにより当該冷暖房設備のランニングコストを算出し、一方、前記負荷側機器の戻り信号に基づいて、多数の負荷側機器のそれぞれについて利用したエネルギー量を算出し、前記のランニングコストに、要すれば係数を乗じて、多数の負荷側機器それぞれの利用エネルギー量に比例配分することを特徴とする、セントラル冷暖房装置の料金算出方法。

【請求項2】 グループ毎に区分した多数の負荷側機器をグループ毎に接続した複数の配管系と、上記複数の配管系のそれぞれに設けられた電動弁と、上記多数の負荷側機器に冷温水を供給する複数の吸収式冷温水機およびその補機よりなる機器と、以上に述べた各機器の運転戻り信号を入力されるとともに、該各機器に対して運転指令信号を出力するセントラル冷暖房装置の料金を算出する装置であって、上記の各機器が消費する電力を検出する電力量計と、水道水量を検出する水量計と、燃料ガス量を検出するガス流量計とを具備しており、上記電力量計の出力信号と、水量計の出力信号と、ガス流量計の出力信号とを入力されて、電気料金、水道料金およびガス料金を算出する演算機能を有するとともに、多数の負荷側機器のそれぞれについて、利用エネルギー量を算出する演算機能を有し、かつ、料金合計を各負荷側機器の利用エネルギーについて比例配分する演算機能を有するコンピュータを具備していることを特徴とする、セントラル冷暖房装置の料金算出装置。

【請求項3】 前記のコンピュータは、前記多数の負荷側機器のそれぞれについて、その能力を記憶する記憶回路と、その運転時間を算定するタイマ回路とを有しており、上記の能力に運転時間を乗じて負荷側機器ごとに利用エネルギー量を算出するものであることを特徴とする、

請求項2に記載したセントラル冷暖房装置の料金算出装置。

【発明の詳細な説明】

【0001】

【産業上の利用分野】本発明は、細分化された負荷側機器を備えたセントラル冷暖房装置において、多数の負荷側機器ごとに適正な料金を自動的に算出する方法、および自動的に算出する装置に関するものである。

【0002】

【従来の技術】集合住宅やテナントビルなどの空調を行う場合、空調負荷が細分化され、かつそれらの空調負荷の時間帯が雑多であって、監視、制御が困難である。集合住宅においては、居住している多数の家族のそれぞれが独自の生活様式を有しているので空調負荷のパターンが多様であることは避け難い。テナントビルにおいては集合住宅に比してこうした問題が少なくとされてきたが、最近ではテナントビルにおいても空調負荷のパターンが多様化する傾向にある。このように、細分化された空調負荷のそれぞれが多様なパターンを有しているという条件下においては、従来一般に電動式パッケージエアコンを用いた個別空調方式が用いられていて、セントラル冷暖房は適用できないとされていた。その理由は、多様化した空調時間帯や負荷変動に対応して緻密な監視、制御が困難なこと、および、多数の空調負荷のそれぞれについて個別に、適正な料金を算出できないことであった。

【0003】

【発明が解決しようとする課題】集合住宅やテナントビルにおける個別空調方式とセントラル冷暖房方式とを比較すると、個別空調方式は一般に設備コストもランニングコストも割高である。また、ビル全体としての受電容量も大きく設定しなければならない。また、個別空調方式ではビルの外壁に多数の屋外機が設置されてビルの美観を損ねるといふ問題も有る。セントラル冷暖房方式は経済的に有利であるにも拘らず、使い勝手の面から昨今のビル空調にマッチしないとして敬遠されている。このように、集合住宅の各家庭やテナントビルの各入居者が、多少のコスト高を承知で使い勝手の良いことを求めるのは、現状ではやむを得ないことではあるが、エネルギー資源の節約という社会的な要請に背くものである。特に、エネルギー資源に乏しい我国の産業を考え合わせると、国家的養成に背くものと言っても過言ではない。本発明は上述の事情に鑑みて為されたものであって、集合住宅やテナントビルなどのように負荷が細分化されている冷暖房設備において、集中熱源機として、ランニングコストが安く、ビル全体の受電容量を抑制し得る吸収式冷温水機を用い、かつ、各居住者のそれぞれが負荷側機器を自由に操作することができ、しかも各負荷側機器ごとに適正な料金を自動的に算出し得る方法、および、上記の方法を実施するに好適な算出装置を提供すること

を目的とする。

【0004】

【課題を解決するための手段】上記の目的を達成するために創作した本発明の基本的原理は、多数の空調負荷（例えばファンコイルユニット）を、空調時間帯が類似しているもの毎のグループに区分して配管系を構成し、グループ単位の監視、制御を行うとともに、消費電力料金、ガス料金、水道料金等を合計したランニングコストを、上記多数の空調負荷（例えばファンコイルユニット）毎の利用エネルギー量に比例配分するものである。上述の原理に基づく具体的な手法として本発明に係る方法は、グループ毎に区分した多数の負荷側機器をグループ毎に接続した複数の配管系と、上記複数の配管系のそれぞれに設けられた電動弁と、上記多数の負荷側機器に冷温水を供給する複数の吸収式冷温水機およびその補機よりなる機器と、以上に述べた各機器の運転戻り信号を入力されるとともに、該各機器に対して運転指令信号を出力するセントラル冷暖房装置の料金を算定する方法であって、前記の各機器が消費した電力をコンピュータに入力して金額に換算し、同じく、消費した水道水量を前記のコンピュータに入力して金額に換算し、同じく、消費した燃料ガス量を前記のコンピュータに入力して金額に換算し、前記各機器に要した付帯経費を前記のコンピュータに入力し、上記の入力値に基づいて、前記のコンピュータにより当該冷暖房設備のランニングコストを算出し、一方、前記負荷側機器の戻り信号に基づいて、多数の負荷側機器のそれぞれについて利用したエネルギー量を算出し、前記のランニングコストに、要すれば係数を乗じて、多数の負荷側機器それぞれの利用エネルギー量に比例配分することを特徴とする。

【0005】また、上記の発明方法を実施するために構成した本発明に係る料金の算出装置は、グループ毎に区分した多数の負荷側機器をグループ毎に接続した複数の配管系と、上記複数の配管系のそれぞれに設けられた電動弁と、上記多数の負荷側機器に冷温水を供給する複数の吸収式冷温水機およびその補機よりなる機器と、以上に述べた各機器の運転戻り信号を入力されるとともに、該各機器に対して運転指令信号を出力するセントラル冷暖房装置の料金を算出する装置であって、上記の各機器が消費する電力を検出する電力量計と、水道水量を検出する水量計と、燃料ガス量を検出するガス流量計とを具備しており、上記電力量計の出力信号と、水量計の出力信号と、ガス流量計の出力信号とを入力されて、電気料金、水道料金およびガス料金を算出する演算機能を有するとともに、多数の負荷側機器のそれぞれについて、利用エネルギー量を算出する演算機能を有し、かつ、料金合計を各負荷側機器の利用エネルギーについて比例配分する演算機能を有するコンピュータを具備していることを特徴とする。

【0006】

【作用】上記の算出装置を用いて前記の算出方法を実施すると、電気料金、ガス料金、水道料金などのランニングコストが自動的に集計されるとともに、多数の負荷側機器（例えばファンコイルユニット）毎に利用したエネルギー量が算出され、かつ、前記のランニングコストが上記の利用エネルギー量について比例配分されて、適正な料金が自動的に算出される。

【0007】

【実施例】図1は本発明に係る料金算出装置を備えたセントラル冷暖房設備の1実施例を示す系統図である。吸収式冷温水機の負荷側機器としてのファンコイルユニットは多数配置されている。本発明において多数とは10以上の整数を言うものとする。これら多数のファンコイルユニットを、その使用条件に基づいて同一ないし類似の負荷パターン（すなわち負荷率と負荷時間帯との関係状態）に区分し、同一ないし類似の負荷パターンを有するファンコイルユニット1a₁、同1a₂、同1a₃をグループaとして一つの配管系を形成し、電動弁2aおよび流量計3を介して可変流量形の冷温水2次ポンプ4の吐出口に接続する。この冷温水2次ポンプ4は冷温水往ヘッダ5から冷温水を供給され、後述のごとく前記流量計3を介して多数の負荷側機器（ファンコイルユニット）に冷温水を圧送して循環させる。負荷側機器を流通した冷温水は2次冷温水戻り温度センサ6を経て冷温水還ヘッダ7に流入する。図示の1b₁、1b₂、1b₃は、相互に負荷パターンの類似するファンコイルユニットであって一つの配管系として接続され、電動弁2bを介してbグループとして前記流量計3の下流側に分岐接続されている。同様に、負荷パターンの類似するファンコイルユニット1c₁、1c₂、1c₃は、cグループとして電動弁2cを介して前記流量計3の下流側に分岐接続されている。前記流量計3の出力信号は流量調節計8を介して動力回路盤9のインバータ10に接続され、インタフェイス盤11を介してコンピュータ12に入力される。同様に、前記の電動弁2a、同2b、同2cの開閉指令信号および開閉戻り信号もインタフェイス盤11を介してコンピュータ12に接続されている。上記のコンピュータ12には、前記ファンコイルユニットの能力および冷温水流量、並びに、次に詳述する吸収式冷温水機15の能力を予め入力しておく。本実施例（図1）においては、前記冷温水還ヘッダ7と冷温水往ヘッダ5との間に5基の吸収式冷温水機15が並列に接続されている。これら5基の吸収式冷温水機15のそれぞれは、冷温水1次ポンプ16を備えており、かつ、冷却水ポンプ17を介して冷却塔18に接続されている。そして、これらの機器で消費される電力Eは発振式電力量計19によりインタフェイス盤11を介してコンピュータ12に入力される。また消費されるガスGは発振式ガス流量計20で、消費される水Wは発振式水量計21で、それぞれインタフェイス盤11を介してコンピュータ12

に入力される。これらのデータは、後述の空調エネルギー課金計算、冷温水可変流量制御、および冷温水発生機の運転台数制御に用いられる。前記のコンピュータ12には居住者リスト、各居住者のファンコイルユニットの配分、電気、ガス、水道のエネルギー単価、および料金計算式を入力し、記憶させておく。以上のように構成された装置(図1)において、各居住者が各居住区内に設けられているファンコイルユニットのスイッチ(図示せず)を任意に操作すると、その運転戻り信号をコンピュータ12が検知し、吸収式冷温水機15とその補機に対して運転指令を出力し、電動弁に対しては開指令を出力する。複数基(本例において5機)の吸収式冷温水機15は、負荷総量の大小に応じて必要台数だけ運転する。すなわち、戻り信号を入力されたファンコイルユニットの能力の合計量をその時点における総負荷量とし、この総負荷量に比して必要かつ充分な台数(端数は切り上げて計算して算出する)の吸収式冷温水機15を運転する。その算定方法の1例を次に示す。ファンコイルユニットの総数を200台とし、それぞれのファンコイルユニットの能力を、FCU-1, FCU-2, FCU-3 ……FCU-200と表わすことにする。そして、各ファンコイルユニットの能力が、

FCU-1	………	α_1	kcal/h
FCU-2	………	α_2	kcal/h
FCU-3	………	α_3	kcal/h
………	………		
………	………		
………	………		
FCU-200	………	α_{200}	kcal/h

であり、
 $\alpha_1 + \alpha_2 + \dots + \alpha_{200} = \alpha t$
 とする。一方、吸収式冷温水機15の1基の能力をQ kcal/hとすると、その数は5基であるから、
 $Q \times 5 = Qt$ ……(1)
 ここで、 αt と Qt とは必ずしも同値ではないので、
 $K = Qt / \alpha t$ ……(2)
 という係数Kを設ける。

【0008】ここで、FCU-1, FCU-5, FCU-12に戻り信号があったとすると、
 $\alpha_1 + \alpha_5 + \alpha_{12}$ ……(3)

従って、吸収式冷温水機の必要運転台数は、 $K \times (\alpha_1 + \alpha_5 + \alpha_{12}) / Q$ となり、この値を切り上げた数字を要求運転台数Nとする。

【0009】上記の要求運転台数Nの算出は、各機器が標準条件で定格の能力を発揮するものと仮定して、負荷側機器が必要とするカロリーを熱源機器1基の能力で除したものである。しかし、実際の運転状態においては各機器が定格状態で作動するとは限らず、若干の余裕を以って作動している場合が多い。従って、必ずしも上記の運転台数Nの吸収式冷温水機15を運転しなくても良い

場合がある。例えば外気温が余り高くないときに冷房運転を行ったり、外気温が余り低くない時に暖房運転を行う場合は、前記のようにして算出した台数Nを運転しなくても足りる。このような、運転状態における余裕の程度(負荷率)は、2次冷温水戻り温度センサ6によって検出される2次冷温水の戻り温度によって判断し得る。すなわち、定格状態における2次冷温水は冷温水往ヘッダ5から7℃で流出し、冷温水還ヘッダ7に12℃で流入する。この冷温水ヘッダ7に流入する2次冷温水の戻り温度が12℃よりも低ければ運転状態に余裕があり、12℃よりも高ければ余裕が無いことになる。そこで、2次冷温水戻り温度に基づいて算出する必要運転台数N'を、次のように設定する。冷房運転の場合、

2次冷温水戻り温度	温度による
センサ6の検出値	必要運転台数
9.5℃以下	N' = 1
11.0℃以下	N' = 2
12.5℃以下	N' = 3
14.0℃以下	N' = 4
14.0℃以上	N' = 5

(全数運転)

実際の運転においては、前述した要求運転台数Nと、上記の温度による必要運転台数N'とをコンピュータ12が比較演算し、いずれか低い方の値をとって吸収式冷温水機15の運転台数を決定し、運転指令信号を出力して運転の監視・制御を行う。また、前記と同様にして暖房運転の場合は、

2次冷温水戻り温度	温度による必要
センサ6の検出値	運転台数
56.5℃以上	N' = 1
55.0℃以上	N' = 2
53.5℃以上	N' = 3
52.0℃以上	N' = 4
52.0℃以下	N' = 5

(全数運転)

なお、定格運転状態における暖房時の2次冷温水は60℃で流出し、55.5℃で流入する。暖房運転の場合も、前述した冷房運転の場合と同様にNとN'との内でいずれか小さい方の値をとる。なお、冷、暖房いずれの場合においても、条件の境界付近での頻繁な運転台数の変化を避ける(N台目またはN'台目の吸収式冷温水機15の頻繁な発停動作を防止するため、不感時間を設けることが望ましい。また、吸収式冷温水機の運転台数制御については、5基の吸収式冷温水機15およびその付属機器の運転時間累計が平均化するよう、運転の優先順位を変更するローテーション機能を設けることも、公知技術を適用して行い得る。さらに、いずれかの吸収式冷温水機15およびその付属機器が故障した場合は、該故障機をスキップして次の吸収式冷温水機を運転するスキップ動作機能を付加しておくことが望ましい。

【0010】次に、電動弁2a、2bへの開閉制御、および同弁の開閉制御による冷温水の流量制御について説明する。多数（本例において200個）のファンコイルユニット1a₁、1a₂、1a₃、1b₁、1b₂への内の何れかが運転されると、この運転を開始したファンコイルユニットの運転戻り信号がコンピュータ12に入力される。該コンピュータ12には、前述のごとく総べてのファンコイルユニットに関する各種の情報が入力されていて、運転戻り信号を受けたファンコイルユニットが属している配管系グループに接続されている電動弁（2a、もしくは2b、又は2cへの内の、いずれか1個以上）のみを開弁させ、他の電動弁は閉じておく。各電動弁の開閉状態が決定されると、冷温水の流量は開状態にある電動弁の必要流量の合計となり、可変流量形の冷温水2次ポンプ4はインバータ10により次に述べるようにして可変流量制御される。すなわち、コンピュータ12は流量調節計8に対して、必要流量に相当する制御用アナログ信号を出力し、又は、ポンプの回転速度-流量特性に基づいてインバータ10に対して必要回転速度に相当する制御用アナログ信号を出力する。また、ファンコイルユニットの運転戻り信号、電動弁の開閉戻り信号、吸収式冷水機とその補機器の運転状態（運転・停止・故障など）戻り信号はインタフェイス盤11を介して瞬時にコンピュータ12が入力検知できるようになっているので、画面表示装置13によって運転状態を表示することができる。上記の表示は図であっても表であっても良い。図2は監視画面の1例である。どのような形で運転状態を表示させるかは任意に設定することができる。また、プリンタ14によってプリントアウトしても良い。このようにして冷暖房設備を構成している各種機器の一括監視が可能である。

【0011】上述のようにして運転状態を監視し制御すると同時に、次に述べるようにして冷暖房料金に関する課金算定を自動的に行わせる。各居住者がファンコイルユニットを操作して運転状態にすると、コンピュータ12はその運転戻り信号によってこれを検知し、当該ファンコイルユニットの運転時間タイマをカウントし始める。このタイマは、当該ファンコイルユニットが停止状態になるとカウントを停止する。上記のタイマは、料金決算の決算日に至るまで積算を続け、料金決算日に運転時間にファンコイルユニットの能力を乗じ、当該ファンコイルユニットの利用熱量を算出する。その具体的な方法は次のごとくである。ファンコイルユニットFCU-1の時間当たり熱量を $\alpha_1 \text{kcal/h}$ とし、その使用時間を $t_1 \text{h}$ とする。ファンコイルユニットFCU-2の時間当たり熱量を $\alpha_2 \text{kcal/h}$ とし、その使用時

間を $t_2 \text{h}$ とする。ファンコイルユニットFCU-3の時間当たり熱量を $\alpha_3 \text{kcal/h}$ とし、以下同様にしてFCU-4からFCU-199までについて時間当たり熱量と使用時間とを定めて、ファンコイルユニットFCU-200の時間当たり熱量を $\alpha_{200} \text{kcal/h}$ とし、その使用時間を $t_{200} \text{h}$ とする。これにより、各ファンコイルユニットの冷暖房利用料金（ランニングコスト原価）は、電気料金+ガス料金+水道料金+付帯経費を、当該ファンコイルユニットの時間当たり熱量×使用時間について比例配分して求められる。すなわち、

（電気料金+ガス料金+水道料金+付帯経費）×（当該ファンコイルユニットの時間当たり熱量×当該ファンコイルユニットの使用時間）÷（ $\alpha_1 t_1 + \alpha_2 t_2 + \alpha_3 t_3 + \dots + \alpha_{200} t_{200}$ ）となる。

居住者が複数のファンコイルユニットを利用している場合は、予めコンピュータ12に入力しておけば、居住者ごとの冷暖房利用料金を自動的に算出してプリンタ14で打ち出すことができる。

【0012】

【発明の効果】以上説明したように、本発明の料金算出装置を用いて本発明の料金算出方法を実施すると、集合住宅やテナントビルなどのように負荷が細分化されているセントラル冷暖房設備において、集中熱源機として、ランニングコストの安い吸収式冷水機を用い、かつ、居住者のそれぞれが負荷側機器を自由に操作することができ、しかも、自由に操作して運転された多数の負荷側機器のそれぞれが利用したエネルギー量に基づく適正な料金を自動的に算出することができる。

【図面の簡単な説明】

【図1】本発明の1実施例における吸収式冷水機を用いた冷暖房設備の配管および制御系統図である。

【図2】上記実施例に係る吸収式冷水機を用いた冷暖房設備における監視画面の平面図である。

【符号の説明】

1a₁、1a₂、1a₃、1b₁、1b₂、1b₃、1c₁、1c₂、1c₃…負荷側機器としてのファンコイルユニット、2a、2b、2c…電動弁、3…流量計、4…冷温水2次ポンプ、5…冷温水往ヘッダ、6…2次冷温水戻り温度センサ、7…冷温水還ヘッダ、8…流量調節計、9…動力回路盤、10…インバータ、11…インタフェイス盤、12…コンピュータ、13…画面表示装置、14…プリンタ、15…吸収式冷水機、16…冷温水1次ポンプ、17…冷却水ポンプ、18…冷却塔、19…発振式電力量計、20…発振式水量計、21…発振式ガス流量計。

【図1】

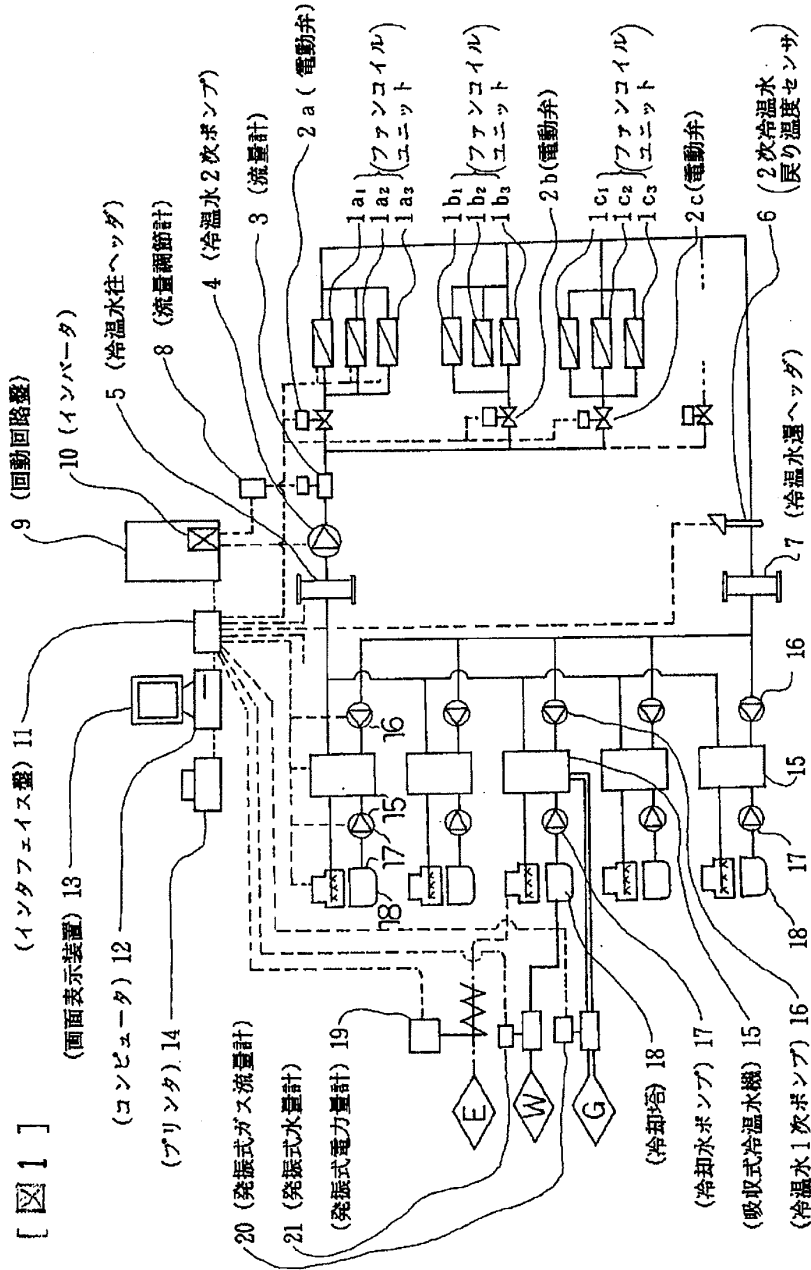

【図1】

【図2】

【図2】

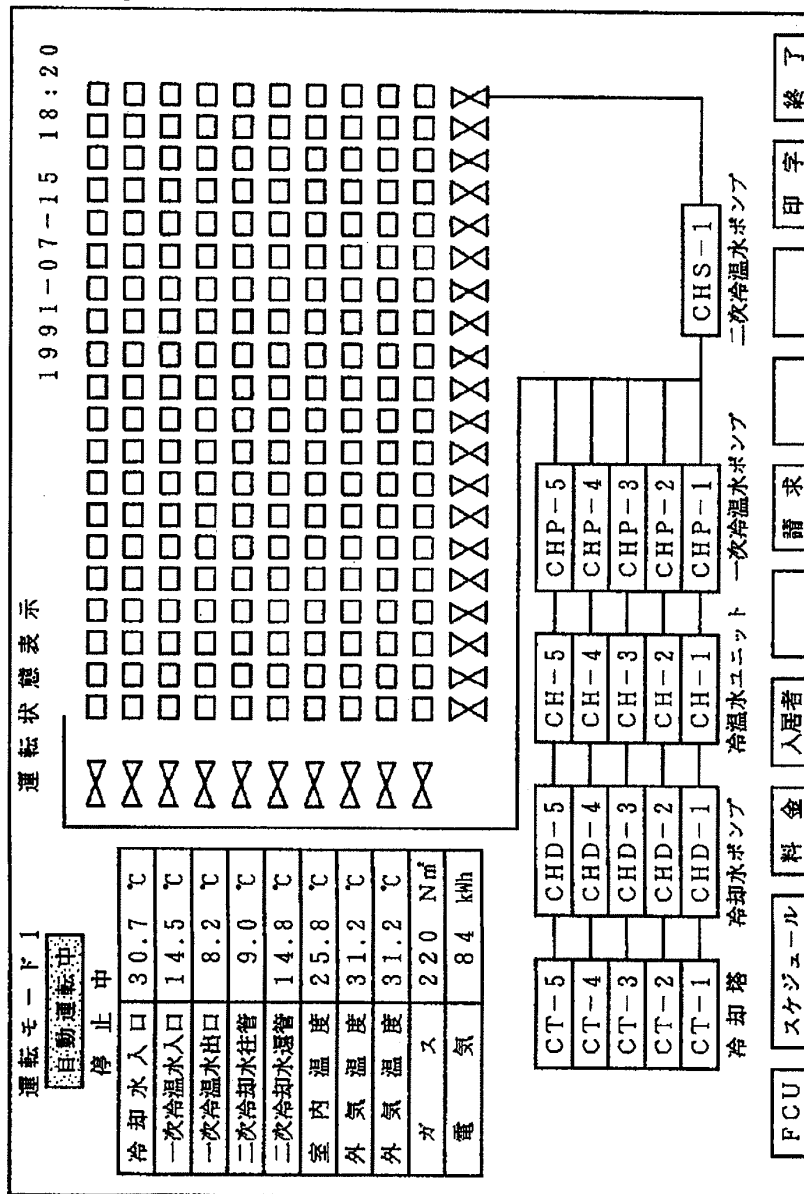



Espacenet

Bibliographic data: JP2010038377 (A) — 2010-02-18

AIR CONDITIONING CHARGE CALCULATING DEVICE

No documents available for this priority number.

Inventor(s): HIRAMATSU SEIJI ± (HIRAMATSU SEIJI)

Applicant(s): MITSUBISHI HEAVY IND LTD ± (MITSUBISHI HEAVY IND LTD)

Classification: - international: **F24F11/02**
- cooperative:

Application number: JP20080198259 20080731

Priority number(s): JP20080198259 20080731

Abstract of JP2010038377 (A)

PROBLEM TO BE SOLVED: To calculate an air conditioning charge by a simple process by resolving complications of software. ; **SOLUTION:** The air conditioning charge calculating device is equipped with a timer device 4, and a central control unit 3 acquiring a charge coefficient associated with a signal inputted from the timer device 4, and calculating the air conditioning charge by using the acquired charge coefficient and power consumption information. ; **COPYRIGHT:** (C) 2010,JPO&INPIT

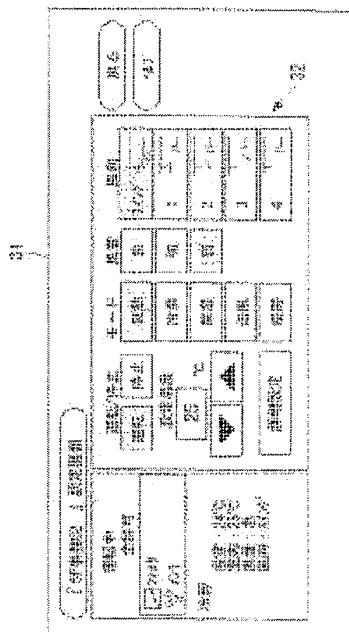

Last updated: 09.10.2013 Worldwide
Database 5.8.11.5; 93p

(19) 日本国特許庁(JP)

(12) 公開特許公報(A)

(11) 特許出願公開番号

特開2010-38377

(P2010-38377A)

(43) 公開日 平成22年2月18日(2010.2.18)

(51) Int. Cl.	F 1	テーマコード(参考)
F24F 11/02 (2008.01)	F 2 4 F 11/02 1 0 3 D	3 L 0 6 0
	F 2 4 F 11/02 1 0 2 T	3 L 0 6 1
	F 2 4 F 11/02 Z	

審査請求 未請求 請求項の数 4 O L (全 7 頁)

(21) 出願番号 特願2008-198259 (P2008-198259)
 (22) 出願日 平成20年7月31日(2008.7.31)

(71) 出願人 000006208
 三菱重工業株式会社
 東京都港区港南二丁目16番5号
 (74) 代理人 100112737
 弁理士 藤田 考晴
 (74) 代理人 100118913
 弁理士 上田 邦生
 (72) 発明者 平松 誠司
 愛知県清須市西枇杷島町旭3丁目1番地
 三菱重工業株式会社冷熱事業本部内
 Fターム(参考) 3L060 AA08 CC10 CC19 EE22
 3L061 BA05 BA06

(54) 【発明の名称】 空調料金計算装置

(57) 【要約】

【課題】ソフトウェアの煩雑さを解消でき、簡便な処理で空調使用料金を計算すること。

【解決手段】タイマ装置4と、タイマ装置4から入力された信号に関連付けられている課金係数を取得し、取得した課金係数と電力消費情報とを用いて空調使用料金を計算する中央制御装置3とを備える空調料金計算装置を提供する。

【選択図】 図2

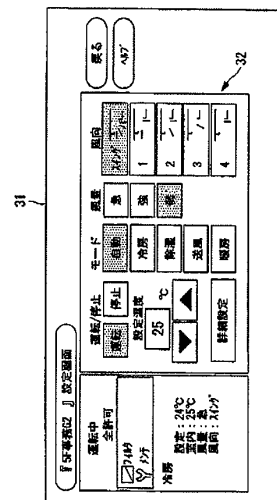

【特許請求の範囲】**【請求項1】**

空気調和システムの空調料金を計算する空調料金計算装置であって、
時間帯と出力する信号とが関連付けられたスケジュール情報を有し、該スケジュール情報に基づいて出力信号を切り替えるタイマ手段と、
該タイマ手段から出力される信号と課金係数とが関連付けられている課金テーブルを有し、該タイマ手段から入力された信号に関連付けられている課金係数を該課金テーブルから取得し、取得した課金係数と電力消費情報とを用いて空調使用料金を計算する料金計算手段と
を具備する空調料金計算装置。

【請求項2】

前記タイマ手段から入力される信号はデジタル信号であり、時間帯に応じてオンオフが切り替えられる請求項1に記載の空調料金計算装置。

【請求項3】

前記料金計算手段は、前記室外機及び複数の前記室内機にネットワークを介して接続されるとともに、前記マルチ型空調和装置の運転スケジュールの管理機能を有する中央制御装置に備えられている請求項1または請求項2に記載の空調料金計算装置。

【請求項4】

1台の室外機と複数の室内機とが接続されるマルチ型空調和装置にネットワークを介して接続されるとともに、該マルチ型空調和装置の運転スケジュールの管理機能を有する中央制御装置であって、

時間帯に応じて出力する信号を切り替えるタイマ手段と接続され、該タイマ手段から受信した信号に応じた課金情報と電力消費情報とを用いて空調使用料金を計算する中央制御装置。

【発明の詳細な説明】**【技術分野】****【0001】**

本発明は、1台の室外機に対して、複数台の室内機が接続されるマルチ型空調和装置に関するものである。

【背景技術】**【0002】**

1台の室外機に対して複数台の室内機が接続されるマルチ型空調和装置が知られている。例えば、1台の室外機に対して20台以上の室内機を接続することのできる大型のマルチ型空調和装置では、複数のテナントにより室内機が使用される場合も少なくない。このような場合、室外機で使用された電気料金については、各室内機の運転時間等で室外機の電気料金を按分し、これに基づいて各テナントの電気料金を決定することが提案されている。

また、特許文献1には、複数の動力を用いて駆動される空調機の料金を計算する方法が開示されている。

【特許文献1】特開2006-125734号公報

【発明の開示】**【発明が解決しようとする課題】****【0003】**

ところで、近年では、定時と定時外とで電気料金の単価を変えたい、定時の時間帯を曜日毎に変更したい等の様々な要望があり、この要望に応じるために、空調の制御を行う集中制御装置において予め定時と定時外の時間帯を設定し、時間帯に応じて電気料金の単価を変更することが提案されている。

しかしながら、集中コントローラにおいて電気料金の単価の管理及び計算を行おうとすると、ソフトウェアが煩雑になる、処理が煩雑になる、多くのメモリ容量を必要とする等の種々の問題があり結果的に非常にハイグレードで高価な製品でしか実現できなかった。

【0004】

本発明は、上記問題を解決するためになされたもので、ソフトウェアの煩雑さを解消でき、簡便な処理で空調使用料金を計算することのできる空調料金計算装置を提供することを目的とする。

【課題を解決するための手段】

【0005】

上記課題を解決するために、本発明は以下の手段を採用する。

本発明は、空気調和システムの空調料金を計算する空調料金計算装置であって、空気調和装置の空調料金を計算する空調料金計算装置であって、時間帯と出力する信号とが関連付けられたスケジュール情報を有し、該スケジュール情報に基づいて出力信号を切り替えるタイマ手段と、該タイマ手段から出力される信号と課金係数とが関連付けられている課金テーブルを有し、該タイマ手段から入力された信号に関連付けられている課金係数を該課金テーブルから取得し、取得した課金係数と電力消費情報とを用いて空調使用料金を計算する料金計算手段とを具備する空調料金計算装置を提供する。

【0006】

上記構成によれば、タイマ手段と料金計算手段とを接続し、タイマ手段から入力される信号に基づいて課金係数を変更することとしたので、料金計算手段においては、煩雑な処理を行うことなく、簡便な処理及び比較的少ないメモリ容量で空調使用料金の計算を行うことが可能となる。

上記空気調和システムとは、少なくとも1台の室外機と少なくとも1台の室内機を有していればよい。

【0007】

上記空調料金計算装置において、前記タイマ手段から入力される信号はデジタル信号であり、時間帯に応じてオンオフが切り替えられることとしてもよい。

【0008】

このように、デジタル信号によって時間帯の切り替えを通知するので、時間帯を容易に判定することができる。

【0009】

上記空調料金計算装置において、前記料金計算手段は、前記室外機及び複数の前記室内機にネットワークを介して接続されるとともに、前記マルチ型空気調和装置の運転スケジュールの管理機能を有する中央制御装置に備えられていることとしてもよい。

【0010】

このように、中央制御装置が料金計算手段を備えるので、追加装置を必要とせず、既存の設備を用いて空調使用料金の計算を行うことができる。

【0011】

本発明は、1台の室外機と複数の室内機とが接続されるマルチ型空気調和装置にネットワークを介して接続されるとともに、該マルチ型空気調和装置の運転スケジュールの管理機能を有する中央制御装置であって、時間帯に応じて出力する信号を切り替えるタイマ手段と接続され、該タイマ手段から受信した信号に応じた課金情報と電力消費情報とを用いて空調使用料金を計算する中央制御装置を提供する。

【発明の効果】

【0012】

本発明によれば、ソフトウェアの煩雑さを解消でき、簡便な処理により空調使用料金を計算することができるという効果を奏する。

【発明を実施するための最良の形態】

【0013】

以下に、本発明に係る空調料金計算装置の一実施形態について、図面を参照して説明する。

図1は、本実施形態に係る空調料金計算装置及び該空調料金計算装置が適用されるマルチ型空気調和装置の概略構成を示したブロック図である。

図1に示されるように、一台の室外機1と、複数の室内機2とを備えるマルチ型空調和装置を複数組備える空調システムに、中央制御装置(センターコンソール)3が接続されている。各室外機1、各室内機2、及び中央制御装置3とは、共通のネットワークを介して接続されている。

図1では、8台の室内機2が設けられている場合を示しているが、室内機2の接続台数については、最大接続台数(例えば、128台)の範囲内で任意に決定することが可能である。

【0014】

中央制御装置3は、図2に示されるように、表示部31及びタッチパネル式の入力部32を備えている。例えば、マルチ型空調和装置が設置されたビルの管理者は、この中央制御装置3の表示部31に表示される情報を確認しながら、タッチパネル式の入力部32を操作することにより、室内機2の運転・運転停止、運転モード、風量、風向等を設定することができるようになっている。また、ビルの管理人は、運転スケジュール、室内機のグループ化等を入力設定することができるようになっている。運転スケジュールは、全ての室内機において共通であってもよいし、グループ毎に設定されていてもよい。

【0015】

また、中央制御装置3は、少なくとも2つの外部入力接点(図示略)を有しており、1つの外部入力接点には図1に示したタイマ装置4が接続され、もう一つの外部入力接点には図1に示した電力量計が接続されており、電力量の計測を実施している。本来、前者のタイマ装置用の外部入力接点は、緊急時に全ての空調機を停止させる緊急停止制御入力用、もしくは電力量が規定値を超えた場合に、電力量を下げる制御を実施するためのデマンド入力用として中央制御装置3に設けられたものであり、本実施形態においては、この外部接点を料金計算のために用いる。つまり、本実施形態では、異なる用途のために予め設けられていた中央制御装置3の外部接点を料金計算のために代用するものである。

【0016】

具体的には、外部接点が開状態から閉状態に変化した場合に、換言すると、入力信号がオフからオンに切り替えられた場合に、特殊制御開始入力と判断していたところ、この外部入力に関するソフトウェアが変更されることにより、外部接点が開状態から閉状態に変化した場合に、後述するように、定時の時間帯から定時外の時間帯に切り替わったと判定するようになっている。

【0017】

タイマ装置4は、時間帯に応じて出力する信号を切り替えるように構成されている。具体的には、タイマ装置4は、時間帯と出力する信号とが関連付けられたスケジュール情報を有しており、このスケジュール情報に基づいて出力信号を切り替える。例えば、タイマ装置4は、図3に示されるように、1日においてオフ信号(第1の信号)を出力する時間帯と、オン信号(第2の信号)を出力する時間帯とが登録されたスケジュール情報を有している。ここでは、定時の時間帯にオフ信号を、定時外の時間帯にオン信号が出力されるようにスケジュールリングされている。

【0018】

図3の例では、スケジュール情報は、平日、土曜日、休祝日の3パターン設けられており、平日は、8時から17時までが定時、土曜日は8時から14時までが定時、休祝日は終日定時外とするスケジュール情報が登録されている。なお、上記オン信号とオフ信号とは逆に設定されていてもよい。

【0019】

また、本実施形態に係る中央制御装置3は、上記タイマ装置4から入力される信号に基づいて、各室内機2の空調使用料金を計算する機能(料金計算手段)を備えている。また、中央制御装置3には、外部入力端子を介してマルチ型空調和装置の電力消費量が入力されるようになっている。

【0020】

具体的には、中央制御装置3は、定時の時間帯に対応する課金係数K1円/kWh及び

定時外の時間帯に対応する課金係数 $K2$ 円/kWhを保有しており、これらの課金係数 $K1$ 、 $K2$ をタイマ4から入力される信号に基づいて選択し、選択した課金係数 $K1$ 、 $K2$ をその時間帯における消費電力量に乗算することで空調使用料金を計算する。

【0021】

例えば、中央制御装置3は、CPU（中央演算装置）、ROM（Read Only Memory）、RAM（Random Access Memory）等を備えており、例えば、ROMには、タイマ装置4から入力される信号に基づいて空調使用料金を計算するための処理手順がプログラムの形式で格納されている。このプログラムをCPUがRAM等に読み出して実行することにより、後述する料金計算を実現させる。

【0022】

次に、上記構成を示すマルチ型空調装置における空調料金の計算方法について説明する。

まず、タイマ装置4は、図3に示したスケジュール情報に基づいて、現在の時間帯に応じた信号を中央制御装置4に出力する。これにより、定時の時間帯にはオフ信号が定時外の時間帯にはオン信号が出力される。

【0023】

中央制御装置3には、タイマ装置4からの信号に基づいて定時の時間帯か否かを判定し、この判定結果に応じた課金係数を取得する。そして、取得した課金係数を外部入力端子を介して入力されるマルチ型空調装置の電力消費量に乗算することで、空調使用料金を算出する。

図4(a)乃至(c)は、定時の時間帯と定時外の時間帯とで区分された平日、土曜日、休祝日の消費電力量をそれぞれ示した図である。

【0024】

これにより、例えば、平日における定時の時間帯の消費電力が $Ci1$ kWh、定時外の時間帯の消費電力が $Co1$ kWh、土曜日の定時の時間帯の消費電力が $Ci2$ kWh、定時外の時間帯の消費電力が $Co2$ kWh、休祝日の定時外の時間帯の消費電力が $Co3$ kWhとすると、1週間における定時の時間帯の電気料金及び定時外の時間帯の電気料金は、以下のように計算される。

【0025】

定時の時間帯における電気料金： $K1 \times (Ci1 + Ci2)$ 円

定時外の時間帯における電気料金： $K2 \times (Co1 + Co2 + Co3)$ 円

【0026】

このようにして、電気料金が求められた後は、例えば、各室内機の使用時間等に応じて電気料金が按分されることで、各室内機の使用料金、更には、各テナントへの請求料金が確定することとなる。

【0027】

以上、説明してきたように、本実施形態に係る空調料金計算装置によれば、中央制御装置が有する既存の外部接点にタイマ装置4を接続し、タイマ装置4から入力される開閉信号（オン・オフ信号）に基づいて定時の時間帯か否かを判定することとしたので、中央制御装置において煩雑な処理を行うことなく、簡便な処理及び比較的少ないメモリ容量で空調使用料金の計算を行うことができる。

また、緊急停止等に使用される目的で予め設けられていた外部接点を代用することにより、簡便なソフトウェアの変更を行うだけで、空調使用料金の計算を中央制御装置3において実現させることができる。これにより、設計変更に伴う時間や労力を削減することができる。

【0028】

なお、上記実施形態においては、異なる用途を目的として、中央制御装置3に予め設けられていた外部接点を介してタイマ装置4からの信号を入力することとしたが、これに代えて、他の通信ポートや他の通信媒体を介して中央制御装置3とタイマ装置4との間の通信を行うこととしてもよい。また、タイマ装置4の機能を中央制御装置3内に設けること

としてもよい。

【0029】

更に、本実施形態では、定時の時間帯か否かにより課金係数を切り替えることとしていたが、時間帯を細分化し、細分化したそれぞれの時間帯に対応する互いに異なる出力信号をスケジュール情報に登録しておき、また、各時間帯に対応する課金係数を課金テーブルに登録しておくことで、より細かい課金を行うことが可能となる。

上記互いに異なる出力信号としては、例えば、周波数等がそれぞれ異なるデジタル信号を使用することができる。

【0030】

また、本実施形態では、中央制御装置に空調使用料金の計算機能を持たせた場合について説明したが、マルチ型空調装置に通信媒体を介して接続される装置を新たに設け、この装置に上述した空調使用料金の計算機能を持たせ、料金計算手段として機能させることとしてもよい。

また、本実施形態では、中央制御装置3に電力量計5を接続する場合について述べたが、空調機がガスヒートポンプの場合には、電力量計5に代えてガス流量計が接続されてもよい。

【図面の簡単な説明】

【0031】

【図1】本発明の一実施形態に係る空調料金計算装置及び該空調料金計算装置が適用されるマルチ型空調システムの全体構成を示したブロック図である。

【図2】図1に示した中央制御装置の概略構成を示した図である。

【図3】スケジュール情報の一例を示した図である。

【図4】タイマ装置からの信号に基づいて消費電力量を定時と定時外に区分した図である。

【符号の説明】

【0032】

- 1 室外機
- 2 室内機
- 3 中央制御装置
- 4 タイマ装置
- 5 電力量計
- 31 表示部
- 32 入力部

【図1】

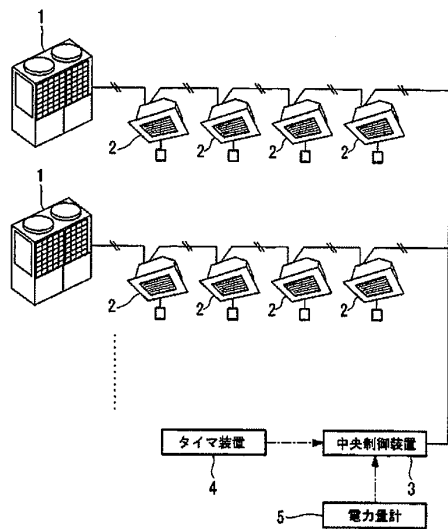

【図2】

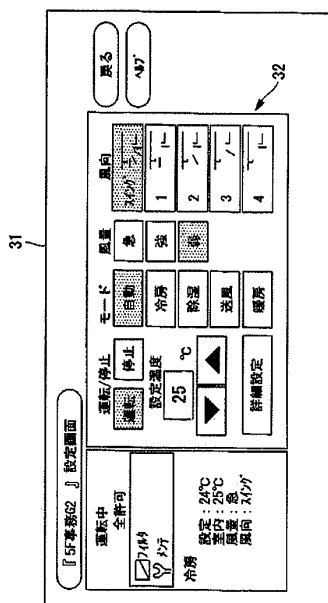

【図3】

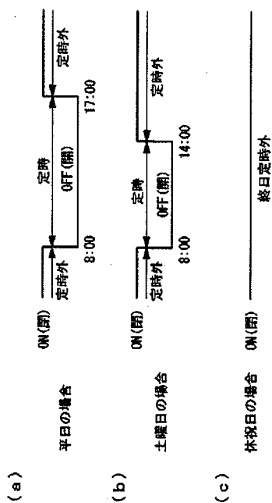

【図4】

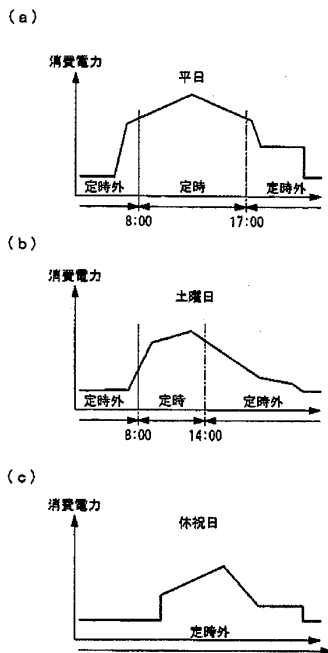

(8)

特開2010-38377(P2010-38377A)



Espacenet

Bibliographic data: JP2010286218 (A) — 2010-12-24

AIR CONDITIONING RATE CALCULATION DEVICE AND AIR CONDITIONING RATE CALCULATION METHOD

No documents available for this priority number.

Inventor(s): HIRAMATSU SEIJI ± (HIRAMATSU SEIJI)

Applicant(s): MITSUBISHI HEAVY IND LTD ± (MITSUBISHI HEAVY IND LTD)

Classification: - international: **F24F11/02**
- cooperative:

Application number: JP20090142184 20090615

Priority number(s): JP20090142184 20090615

Abstract of JP2010286218 (A)

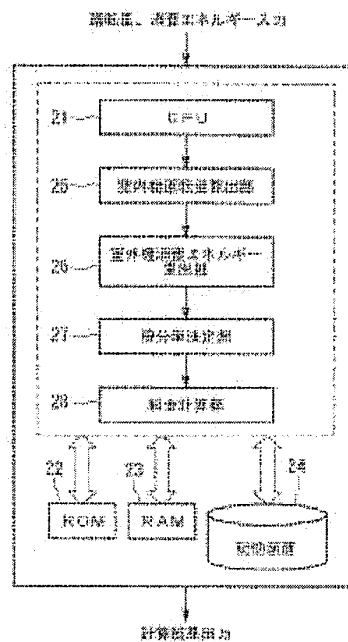

PROBLEM TO BE SOLVED: To perform appropriate proportional rate division with respect to the standby power of an outdoor unit. ; **SOLUTION:** The air-conditioning-rate calculation device 5 for proportionally dividing the utility rate of an air conditioning system constituted by connecting a plurality of indoor units connected to at least one outdoor unit or including a plurality of refrigerant systems to each of the indoor units or a user of each indoor unit includes: a first calculation means 25 which calculates an operation quantity of each of the plurality of indoor units; a second calculation means 26 which calculates a consumed energy quantity of the outdoor unit; a proportional division rate determination means 27 which determines a proportional division rate of the consumed energy quantity of the outdoor unit based on the operation quantity of each indoor unit; and a rate calculation means 28 which calculates a utility rate of the outdoor unit based on the consumed energy quantity of the outdoor unit and the proportional division rate. ;
COPYRIGHT: (C)2011,JPO&INPIT

Last updated: 09.10.2013 Worldwide Database 5.8.11.5; 93p

(19) 日本国特許庁(JP)

(12) 公開特許公報(A)

(11) 特許出願公開番号

特開2010-286218

(P2010-286218A)

(43) 公開日 平成22年12月24日(2010.12.24)

(51) Int.Cl.	F 1	テーマコード(参考)
F 2 4 F 11/02 (2006.01)	F 2 4 F 11/02 1 0 3 D	3 L 0 6 1
	F 2 4 F 11/02 1 0 3 C	

審査請求 未請求 請求項の数 7 O L (全 10 頁)

(21) 出願番号 特願2009-142184 (P2009-142184)
 (22) 出願日 平成21年6月15日(2009.6.15)

(71) 出願人 000006208
 三菱重工業株式会社
 東京都港区港南二丁目16番5号
 (74) 代理人 100112737
 弁理士 藤田 考晴
 (74) 代理人 100118913
 弁理士 上田 邦生
 (72) 発明者 平松 誠司
 東京都港区港南二丁目16番5号 三菱重
 工業株式会社内
 Fターム(参考) 3L061 BA04 BA05 BF06 BF08

(54) 【発明の名称】 空調料金計算装置及び空調料金計算方法

(57) 【要約】

【課題】 室外機の待機電力について適正な料金按分をすることを目的とする。

【解決手段】 少なくとも一つの室外機に対して複数の室内機を接続して構成される1または複数の冷媒系統を備える空調システムの使用料金を、前記各室内機又は前記各室内機の利用者に按分する空調料金計算装置5であって、複数の室内機の運転量をそれぞれ算出する第1算出手段25と、室外機の消費エネルギー量を算出する第2算出手段26と、各室内機の運転量に基づいて、前記室外機の消費エネルギー量の按分率を決定する按分率決定手段27と、室外機の消費エネルギー量と前記按分率とに基づいて前記室外機の使用料金を計算する料金計算手段28と、を備える。

【選択図】 図2

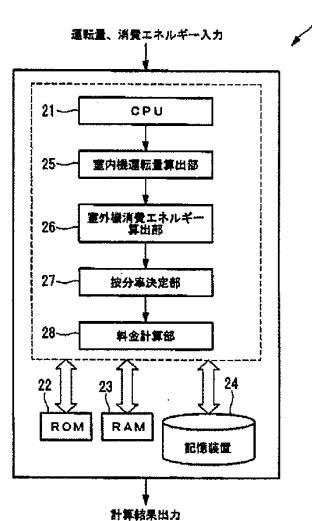

【特許請求の範囲】**【請求項1】**

少なくとも一つの室外機に対して複数の室内機を接続して構成される1または複数の冷媒システムを備える空調システムの使用料金を、前記各室内機又は前記各室内機の利用者に按分する空調料金計算装置であって、

前記複数の室内機の運転量をそれぞれ算出する第1算出手段と、

前記室外機の消費エネルギー量を算出する第2算出手段と、

前記各室内機の運転量に基づいて、前記室外機の消費エネルギー量の按分率を決定する按分率決定手段と、

前記室外機の消費エネルギー量と前記按分率とに基づいて前記室外機の使用料金を計算する料金計算手段と、

を備えたことを特徴とする空調料金計算装置。

【請求項2】

少なくとも一つの室外機に対して複数の室内機を接続して構成される1または複数の冷媒システムを備える空調システムの使用料金を、前記各室内機又は前記各室内機の利用者に按分する空調料金計算装置であって、

前記複数の室内機の運転量をそれぞれ所定期間毎に算出する第1算出手段と、

前記室外機の消費エネルギー量を所定期間毎に算出する第2算出手段と、

前記所定期間毎の各室内機の運転量に基づいて、前記所定期間毎の前記室外機の消費エネルギー量の按分率を決定すると共に、所定期間のうち第1の所定期間の前記各室内機の運転量が零である場合に、所定期間のうち第2の所定期間における前記各室内機の運転量に基づいて、前記第1の所定期間の前記室外機の消費エネルギー量の按分率を決定する按分率決定手段と、

前記室外機の消費エネルギー量と前記按分率とに基づいて前記室外機の所定期間毎の使用料金を計算する料金計算手段と、

を備えたことを特徴とする空調料金計算装置。

【請求項3】

前記按分率決定手段は、前記第1の所定期間及び前記第2の所定期間の前記各室内機の運転量が零である場合に、所定期間のうち第3の所定期間における前記各室内機の運転量に基づいて、前記第1の所定期間の前記室外機の消費エネルギー量の按分率を決定することを特徴とする請求項2に記載の空調料金計算装置。

【請求項4】

前記所定期間が一日間であり、かつ、前記第2の所定期間が前記第1の所定期間の翌日又は前日であることを特徴とする請求項3に記載の空調料金計算装置。

【請求項5】

前記第3の期間は、前記第2の期間以降又は以前の前記各室内機の運転量が零とならない日であることを特徴とする請求項3又は請求項4に記載の空調料金計算装置。

【請求項6】

少なくとも一つの室外機に対して複数の室内機を接続して構成される1または複数の冷媒システムを備える空調システムの使用料金を、前記各室内機又は前記各室内機の利用者に按分する空調料金計算方法であって、

前記複数の室内機の運転量をそれぞれ算出する第1算出ステップと、

前記室外機の消費エネルギー量を算出する第2算出ステップと、

前記各室内機の運転量に基づいて、前記室外機の運転量の按分率を決定する按分率決定ステップと、

前記室外機の消費エネルギー量と前記按分率とに基づいて前記室外機の使用料金を計算する料金計算ステップと、

を備えたことを特徴とする空調料金計算方法。

【請求項7】

少なくとも一つの室外機に対して複数の室内機を接続して構成される1または複数の冷媒系統を備える空調システムの使用料金を、前記各室内機又は前記各室内機の利用者に按分する空調料金計算方法であって、

前記複数の室内機の運転量をそれぞれ所定期間毎に算出する第1算出ステップと、

前記室外機の消費エネルギー量を所定期間毎に算出する第2算出ステップと、

前記所定期間毎の各室内機の運転量に基づいて、前記所定期間毎の前記室外機の消費エネルギー量の按分率を決定すると共に、所定期間のうち第1の所定期間の前記各室内機の運転量が零である場合に、所定期間のうち第2の所定期間における前記各室内機の運転量に基づいて、前記第1の所定期間の前記室外機の消費エネルギー量の按分率を決定する按分率決定ステップと、

前記室外機の消費エネルギー量と前記按分率とに基づいて前記室外機の所定期間毎の使用料金を計算する料金計算ステップと、

【発明の詳細な説明】する空調料金計算方法。

【技術分野】

【0001】

本発明は、空調料金計算装置に係り、特に、少なくとも一つの室外機と複数の室内機とを有する空調システムを集中管理し、該空調システムの消費エネルギーにかかる料金を按分計算する空調料金計算装置に関するものである。

【背景技術】

【0002】

従来より、少なくとも一つの室外機に対して複数の室内機を接続して構成される1または複数の冷媒系統を備えるマルチ空調システムが知られている。そして、オフィスビルやテナントビル等では、このようなマルチ空調システムを集中管理して、複数の室内機の利用者それぞれに対して空調システムの使用料金を按分することが行われている。

例えば、特許文献1には、一台又は複数台の室外ユニットと複数台の室内ユニットとを接続して構成される複数の冷媒系統を備える空調システムにおいて、各冷媒系統の運転制御および全冷媒系統で消費する全エネルギー消費量を各冷媒系統毎に按分し、さらに、それぞれの室内ユニット毎に按分させることで、各冷媒系統毎に運転状態が異なっても適正な料金按分を行う技術が開示されている。

【図面の簡単な説明】

【0019】

【図1】本発明の実施形態に係る空調料金計算装置が適用される空調システムの概略構成を示すブロック図である。

【図2】本発明の実施形態に係る空調料金計算装置の概略構成を示すブロック図である。

【図3】本発明の実施形態に係る空調料金計算装置にかかる記憶装置に記憶される運転時間及び消費電力量の例を示す図表である。

【図4】本発明の実施形態に係る空調料金計算装置にかかる空調料金計算処理の流れを示すフローチャートである。

【符号の説明】

【0041】

- 1 空調システム
- 2 室外機
- 3 a～3 d 室内機
- 5 空調料金計算装置
- 25 室内機運転量算出部
- 26 室外機消費エネルギー算出部
- 27 按分率決定部
- 28 料金計算部

【図1】

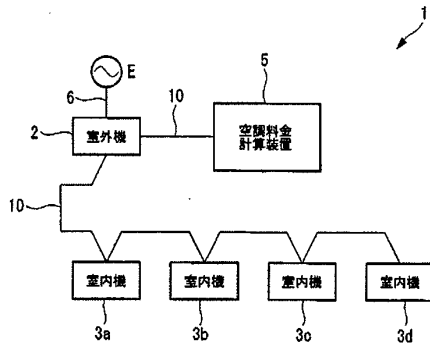

【図2】

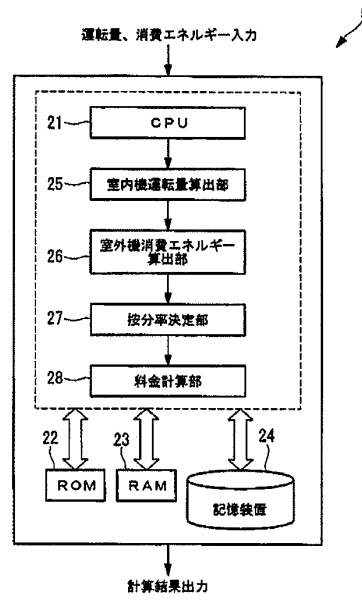

(6)

特開2010-286218(P2010-286218A)

【図3】

年月日	室外機	室内機3a	室内機3b	室内機3c	室内機3d
:	:	:	:	:	:
2009年4月24日	10kw	0	0	0	0
2009年4月25日	30kw	0	0	0	0
2009年4月26日	20kw	0	20h	0	10h
:	:	:	:	:	:
4月分	60kw		40h		20h

【図4】

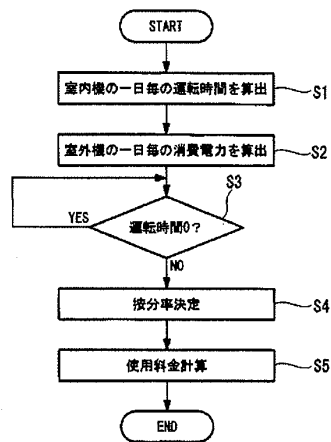

Print Save Error Report

(19) KOREAN INTELLECTUAL PROPERTY OFFICE

KOREAN PATENT ABSTRACTS

(11) Registration number: 100285833 B1
 (45) Issue date: 16.04.2001
 (24) Registration date: 08.01.2001

(21) Application number: 1019980005162 (73) Proprietor:
 (22) Application date: 19.02.1998 (72) Inventor: ● CHOI, GWANG SU
 (51) Int. Cl: F24F 11/02

(54) AIR CONDITIONER WITH METERING FUNCTION AND METHOD FOR CONTROLLING OPERATION OF AIR CONDITIONER

(57) Abstract:

PURPOSE: An air conditioner with metering function and its control method is provided to prevent power waste by displaying the power consumption and corresponding electric charge.

CONSTITUTION: An air conditioner comprises a key input unit(110) for permitting a user to input operation command and set a target electric charge; a temperature sensing unit(160) for sensing the indoor temperature; a load driving unit(140) for performing cooling or heating operation by driving a compressor and motor; a power detection unit(120) for detecting power consumed during cooling or heating operation; a micro computer(130) for controlling operation of the load driving unit in accordance with the operation command input through the key input unit and the indoor temperature sensed by the temperature sensing unit, calculating an electric charge and estimated electric charge from the power detected by the power detection unit, and controlling operation of the load driving unit in accordance with the result of comparison between the target electric charge and the estimated electric charge; and a display unit(150) for selectively displaying the operation state, electric charge and estimated electric charge in accordance with the control of the micro computer.



copyright KIPO 2002

※ If you cannot see the image above, please install the TIFF Viewer and try again.



Legal Status

No.	Receipt/Delivery No.	Receipt/Delivery Date	Document Title (KOR.)	Status (KOR.)

1	1-1-1998-0016443-41	1998.02.19	Request for Examination (출원심사청구서)	Acceptance (수리)
2	1-1-1998-0016441-50	1998.02.19	Patent Application (특허출원서)	Acceptance (수리)
3	1-1-1998-0016442-06	1998.02.19	Notification of assignment of agent (대리인선임신고서)	Acceptance (수리)
4	4-1-1999-0002075-52	1999.01.08	Notification of change of applicant's information (출원인정보변경(경정)신고서)	Acceptance (수리)
5	4-1-1999-0027796-82	1999.02.03	Notification of change of applicant's information (출원인정보변경(경정)신고서)	Acceptance (수리)
6	4-1-1999-0119956-71	1999.09.18	Notification of change of applicant's information (출원인정보변경(경정)신고서)	Acceptance (수리)
7	4-1-2000-0106069-21	2000.08.09	Notification of change of applicant's information (출원인정보변경(경정)신고서)	Acceptance (수리)
8	9-5-2000-0205036-79	2000.08.21	Notification of reason for refusal (의견제출통지서)	Dispatched (발송처리완료)
9	1-1-2000-5317817-51	2000.10.19	Written Opinion (의견서)	Acceptance (수리)
10	1-1-2000-5317818-07	2000.10.19	Amendment to Description, etc. (명세서등보정서)	Acceptance of amendment (보정승인)
11	9-5-2000-0331688-94	2000.12.21	Decision to grant (등록사정서)	Dispatched (발송처리완료)
12	4-1-2002-0039038-35	2002.04.30	Notification of change of applicant's information (출원인정보변경(경정)신고서)	Acceptance (수리)
13	4-1-2002-0079231-78	2002.10.11	Notification of change of applicant's information (출원인정보변경(경정)신고서)	Acceptance (수리)
14	4-1-2003-0000806-26	2003.01.07	Notification of change of applicant's information (출원인정보변경(경정)신고서)	Acceptance (수리)
15	4-1-2003-5079986-93	2003.12.02	Notification of change of applicant's information (출원인정보변경(경정)신고서)	Acceptance (수리)
16	4-1-2005-5072608-11	2005.07.15	Notification of change of applicant's information (출원인정보변경(경정)신고서)	Acceptance (수리)
17	4-1-2005-5079334-14	2005.08.02	Notification of change of applicant's information (출원인정보변경(경정)신고서)	Acceptance (수리)
18	4-1-2012-5132663-40	2012.06.21	Notification of change of applicant's information (출원인정보변경(경정)신고서)	Acceptance (수리)

(19) World Intellectual Property Organization
International Bureau



(43) International Publication Date
1 December 2011 (01.12.2011)

(10) International Publication Number
WO 2011/149600 A3

- (51) International Patent Classification:
F24F 11/02 (2006.01) H04Q 9/04 (2006.01)
- (21) International Application Number:
PCT/US2011/032537
- (22) International Filing Date:
14 April 2011 (14.04.2011)
- (25) Filing Language: English
- (26) Publication Language: English
- (30) Priority Data:
12/788,246 26 May 2010 (26.05.2010) US
- (71) Applicant (for all designated States except US): **ECO-FACTOR, INC.** [US/US]; 423 Broadway, #801, Millbrae, CA 94030 (US).
- (72) Inventor; and
- (75) Inventor/Applicant (for US only): **STEINBERG, John, Douglas** [US/US]; 873 Hacienda Way, Millbrae, CA 94030 (US).

- (74) Agent: **KING, John, R.**; Knobbe, Martens, Olson & Bear, LLP, 2040 Main Street, 14th Floor, Irvine, CA 92614 (US).
- (81) Designated States (unless otherwise indicated, for every kind of national protection available): AE, AG, AL, AM, AO, AT, AU, AZ, BA, BB, BG, BH, BR, BW, BY, BZ, CA, CH, CL, CN, CO, CR, CU, CZ, DE, DK, DM, DO, DZ, EC, EE, EG, ES, FI, GB, GD, GE, GH, GM, GT, HN, HR, HU, ID, IL, IN, IS, JP, KE, KG, KM, KN, KP, KR, KZ, LA, LC, LK, LR, LS, LT, LU, LY, MA, MD, ME, MG, MK, MN, MW, MX, MY, MZ, NA, NG, NI, NO, NZ, OM, PE, PG, PH, PL, PT, RO, RS, RU, SC, SD, SE, SG, SK, SL, SM, ST, SV, SY, TH, TJ, TM, TN, TR, TT, TZ, UA, UG, US, UZ, VC, VN, ZA, ZM, ZW.
- (84) Designated States (unless otherwise indicated, for every kind of regional protection available): ARIPO (BW, GH, GM, KE, LR, LS, MW, MZ, NA, SD, SL, SZ, TZ, UG, ZM, ZW), Eurasian (AM, AZ, BY, KG, KZ, MD, RU, TJ, TM), European (AL, AT, BE, BG, CH, CY, CZ, DE, DK, EE, ES, FI, FR, GB, GR, HR, HU, IE, IS, IT, LT, LU,

[Continued on next page]

(54) Title: SYSTEM AND METHOD FOR USING A MOBILE ELECTRONIC DEVICE TO OPTIMIZE AN ENERGY MANAGEMENT SYSTEM

WO 2011/149600 A3

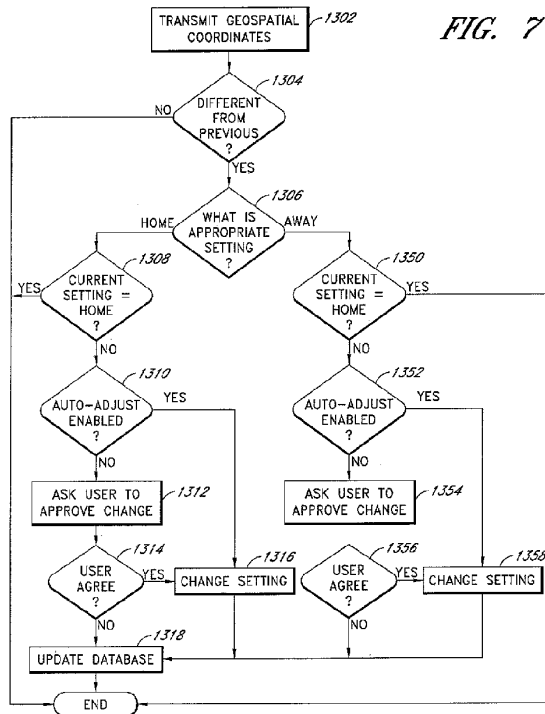

(57) Abstract: Embodiments of the invention comprise systems and methods for using the geographic location of networked consumer electronics devices as indications of occupancy of a structure for purposes of automatically adjusting the temperature setpoint on a thermostatic HVAC control. At least one thermostat is located inside a structure and is used to control an HVAC system in the structure. At least one mobile electronic device is used to indicate the state of occupancy of the structure. The state of occupancy is used to alter the setpoint on the thermostatic HVAC control to reduce unneeded conditioning of unoccupied spaces.



LV, MC, MK, MT, NL, NO, PL, PT, RO, RS, SE, SI, SK,
SM, TR), OAPI (BF, BJ, CF, CG, CI, CM, GA, GN, GQ,
GW, ML, MR, NE, SN, TD, TG).

— *before the expiration of the time limit for amending the
claims and to be republished in the event of receipt of
amendments (Rule 48.2(h))*

Declarations under Rule 4.17:

— *as to applicant's entitlement to apply for and be granted
a patent (Rule 4.17(ii))*

(88) Date of publication of the international search report:



2 February 2012

Published:

— *with international search report (Art. 21(3))*

INTERNATIONAL SEARCH REPORT

International application No.
PCT/US2011/032537

A. CLASSIFICATION OF SUBJECT MATTER		
<i>F24F 11/02(2006.01)i, H04Q 9/04(2006.01)i</i>		
According to International Patent Classification (IPC) or to both national classification and IPC		
B. FIELDS SEARCHED		
Minimum documentation searched (classification system followed by classification symbols) F24F 11/02; G06F 17/00; G05D 23/00; F25B 9/00		
Documentation searched other than minimum documentation to the extent that such documents are included in the fields searched Korean utility models and applications for utility models Japanese utility models and applications for utility models		
Electronic data base consulted during the international search (name of data base and, where practicable, search terms used) eKOMPASS(KIPO internal) & Keywords: mobile, geographic, location, temperature		
C. DOCUMENTS CONSIDERED TO BE RELEVANT		
Category*	Citation of document, with indication, where appropriate, of the relevant passages	Relevant to claim No.
A	US 2006-0214014 A1 (CULLEN BASH et al.) 28 September 2006 See Abstract	1-22
A	US 2004-0176880 A1 (MICHAEL L. OBRADOVICH et al.) 09 September 2004 See Column 124-126	1-22
<input type="checkbox"/> Further documents are listed in the continuation of Box C. <input checked="" type="checkbox"/> See patent family annex.		
* Special categories of cited documents: "A" document defining the general state of the art which is not considered to be of particular relevance "E" earlier application or patent but published on or after the international filing date "L" document which may throw doubts on priority claim(s) or which is cited to establish the publication date of citation or other special reason (as specified) "O" document referring to an oral disclosure, use, exhibition or other means "P" document published prior to the international filing date but later than the priority date claimed		"T" later document published after the international filing date or priority date and not in conflict with the application but cited to understand the principle or theory underlying the invention "X" document of particular relevance; the claimed invention cannot be considered novel or cannot be considered to involve an inventive step when the document is taken alone "Y" document of particular relevance; the claimed invention cannot be considered to involve an inventive step when the document is combined with one or more other such documents, such combination being obvious to a person skilled in the art "&" document member of the same patent family
Date of the actual completion of the international search 12 DECEMBER 2011 (12.12.2011)		Date of mailing of the international search report 12 DECEMBER 2011 (12.12.2011)
Name and mailing address of the ISA/KR  Korean Intellectual Property Office Government Complex-Daejeon, 189 Cheongsa-ro, Seo-gu, Daejeon 302-701, Republic of Korea Facsimile No. 82-42-472-7140		Authorized officer JANG, GI JEONG Telephone No. 82-42-481-5498 

INTERNATIONAL SEARCH REPORT
Information on patent family members

International application No.
PCT/US2011/032537

Patent document cited in search report	Publication date	Patent family member(s)	Publication date
US 2006-0214014 A1	28.09.2006	US 7640760 B2	05.01.2010
US 2004-0176880 A1	09.09.2004	AT 356734 T	15.04.2007
		AT 399110 T	15.07.2008
		AU 6245398 A	26.08.1998
		AU 6245398 A	26.08.1998
		CA 2283843 A1	13.08.1998
		CA 2283843 C	20.11.2007
		CA 2596489 A1	13.08.1998
		DE 69837318 D1	16.10.2008
		EP 0956219 A2	17.11.1999
		EP 0956219 A2	30.10.2002
		EP 0956219 A4	24.01.2001
		EP 0956219 B1	25.06.2008
		JP 2002-505631 A	19.02.2002
		JP 2002-505631 T	19.02.2002
		JP 2002-505631 T	19.02.2002
		US 06009355A A	28.12.1999
		US 06131060A A	10.10.2000
		US 2001-0020202 A1	06.09.2001
		US 2001-0021887 A1	13.09.2001
		US 2001-0029410 A1	11.10.2001
		US 2001-0038414 A1	08.11.2001
		US 2002-0065585 A1	30.05.2002
		US 2002-0082751 A1	27.06.2002
		US 2002-0082752 A1	27.06.2002
		US 2002-0156555 A1	24.10.2002
		US 2002-0198635 A1	26.12.2002
		US 2003-0004616 A1	02.01.2003
		US 2004-0162645 A1	19.08.2004
		US 2004-0162646 A1	19.08.2004
		US 2005-0165513 A1	28.07.2005
		US 2005-0203674 A1	15.09.2005
		US 2006-0200285 A1	07.09.2006
		US 2010-0175014 A1	08.07.2010
		US 6175782 B1	16.01.2001
		US 6233506 B1	15.05.2001
		US 6282464 B1	28.08.2001
		US 6330497 B1	11.12.2001
		US 6438465 B2	20.08.2002
		US 6449535 B1	10.09.2002
		US 6459961 B1	01.10.2002
		US 6542794 B2	01.04.2003
		US 6542795 B2	01.04.2003
		US 6577928 B2	10.06.2003
		US 6587758 B2	01.07.2003
		US 6587759 B2	01.07.2003
		US 6859687 B2	22.02.2005
		US 6922616 B2	26.07.2005

INTERNATIONAL SEARCH REPORT
Information on patent family members

International application No.
PCT/US2011/032537

Patent document cited in search report	Publication date	Patent family member(s)	Publication date
		US 7062362 B2	13.06.2006
		US 7124004 B2	17.10.2006
		US 7171291 B2	30.01.2007
		US 7499778 B2	03.03.2009
		WO 98-34812 A2	13.08.1998
		WO 98-34812A2	13.08.1998
		WO 98-34812A3	05.11.1998
		WO 98-34812A3	05.11.1998

(12) INTERNATIONAL APPLICATION PUBLISHED UNDER THE PATENT COOPERATION TREATY (PCT)

(19) World Intellectual Property
Organization
International Bureau



(10) International Publication Number
WO 2012/024534 A3

(43) International Publication Date
23 February 2012 (23.02.2012)

- (51) International Patent Classification:
F24F 11/02 (2006.01) *H04L 12/16* (2006.01)
H04L 12/12 (2006.01)
- (21) International Application Number:
PCT/US2011/048316
- (22) International Filing Date:
18 August 2011 (18.08.2011)
- (25) Filing Language: English
- (26) Publication Language: English
- (30) Priority Data:
12/860,821 20 August 2010 (20.08.2010) US
- (71) Applicant (for all designated States except US): **ECO-FACTOR, INC.** [US/US]; 432 Broadway, #801, Millbrae, CA 94030 (US).
- (72) Inventor; and
- (75) Inventor/Applicant (for US only): **STEINBERG, John, Douglas** [US/US]; 873 Hacienda Way, Millbrae, CA 94030 (US).
- (74) Agent: **KING, John, R.**; Knobbe, Martens, Olson & Bear, LLP, 2040 Main Street, 14th Floor, Irvine, CA 92614 (US).
- (81) Designated States (unless otherwise indicated, for every kind of national protection available): AE, AG, AL, AM, AO, AT, AU, AZ, BA, BB, BG, BH, BR, BW, BY, BZ, CA, CH, CL, CN, CO, CR, CU, CZ, DE, DK, DM, DO,

DZ, EC, EE, EG, ES, FI, GB, GD, GE, GH, GM, GT, HN, HR, HU, ID, IL, IN, IS, JP, KE, KG, KM, KN, KP, KR, KZ, LA, LC, LK, LR, LS, LT, LU, LY, MA, MD, ME, MG, MK, MN, MW, MX, MY, MZ, NA, NG, NI, NO, NZ, OM, PE, PG, PH, PL, PT, QA, RO, RS, RU, SC, SD, SE, SG, SK, SL, SM, ST, SV, SY, TH, TJ, TM, TN, TR, TT, TZ, UA, UG, US, UZ, VC, VN, ZA, ZM, ZW.

(84) Designated States (unless otherwise indicated, for every kind of regional protection available): ARIPO (BW, GH, GM, KE, LR, LS, MW, MZ, NA, SD, SL, SZ, TZ, UG, ZM, ZW), Eurasian (AM, AZ, BY, KG, KZ, MD, RU, TJ, TM), European (AL, AT, BE, BG, CH, CY, CZ, DE, DK, EE, ES, FI, FR, GB, GR, HR, HU, IE, IS, IT, LT, LU, LV, MC, MK, MT, NL, NO, PL, PT, RO, RS, SE, SI, SK, SM, TR), OAPI (BF, BJ, CF, CG, CI, CM, GA, GN, GQ, GW, ML, MR, NE, SN, TD, TG).

Declarations under Rule 4.17:

— as to applicant's entitlement to apply for and be granted a patent (Rule 4.17(ii))

Published:

— with international search report (Art. 21(3))

— before the expiration of the time limit for amending the claims and to be republished in the event of receipt of amendments (Rule 48.2(h))

(88) Date of publication of the international search report:

31 May 2012

(54) Title: SYSTEM AND METHOD FOR OPTIMIZING USE OF PLUG-IN AIR CONDITIONERS AND PORTABLE HEATERS

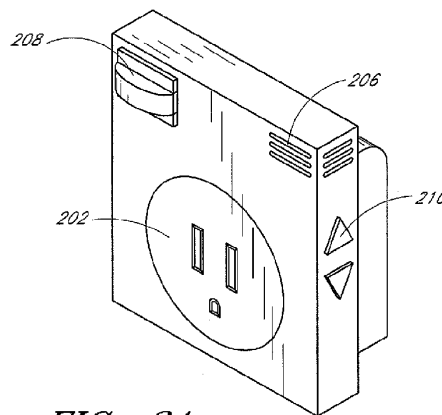



FIG. 3A

(57) Abstract: Thermostatic HVAC and other energy management controls that are connected to a computer network. For instance, remotely managed load switches incorporating thermostatic controllers inform an energy management system, to provide enhanced efficiency, and to verify demand response with plug-in air conditioners and heaters. At least one load control device at a first location comprises a temperature sensor and a microprocessor. The load control device is configured to connect or disconnect electrical power to the an attached air conditioner or heater, and the microprocessor is configured to communicate over a network. In addition, the load control device is physically separate from an air conditioner or heater but located inside the space conditioned by the air conditioner or heater.

WO 2012/024534 A3

INTERNATIONAL SEARCH REPORT

International application No.
PCT/US2011/048316

A. CLASSIFICATION OF SUBJECT MATTER		
<i>F24F 11/02(2006.01)i, H04L 12/12(2006.01)i, H04L 12/16(2006.01)i</i>		
According to International Patent Classification (IPC) or to both national classification and IPC		
B. FIELDS SEARCHED		
Minimum documentation searched (classification system followed by classification symbols) F24F 11/02; H05K 7/20; F04D 27/00; F24F 11/00; F24F 13/08; F24H 9/20; F24F 3/044		
Documentation searched other than minimum documentation to the extent that such documents are included in the fields searched Korean utility models and applications for utility models Japanese utility models and applications for utility models		
Electronic data base consulted during the international search (name of data base and, where practicable, search terms used) eKOMPASS(KIPO internal) & Keywords: control, temperature, compare, database		
C. DOCUMENTS CONSIDERED TO BE RELEVANT		
Category*	Citation of document, with indication, where appropriate, of the relevant passages	Relevant to claim No.
Y	KR 10-1994-0011902 A (Koryo Digital Elect. Co.) 22 June 1994 See Abstract, Claim 1	1-33
Y	KR 10-2000-0059532 A (Dang Hae System Co.) 05 October 2000 See Claims 3, 4	1-33
Y	EP 0415747 A2 (SHAW, ALLAN, DR. et al.) 06 March 1991 See Claim 1	1-33
Y	US 2008-0198549 A1 (RASMUSSEN NETL et al.) 21 August 2008 See Claim 1, Fig. 4, Para. 67, 82	1-33
<input type="checkbox"/> Further documents are listed in the continuation of Box C. <input checked="" type="checkbox"/> See patent family annex.		
* Special categories of cited documents: "A" document defining the general state of the art which is not considered to be of particular relevance "E" earlier application or patent but published on or after the international filing date "L" document which may throw doubts on priority claim(s) or which is cited to establish the publication date of citation or other special reason (as specified) "O" document referring to an oral disclosure, use, exhibition or other means "P" document published prior to the international filing date but later than the priority date claimed		"T" later document published after the international filing date or priority date and not in conflict with the application but cited to understand the principle or theory underlying the invention "X" document of particular relevance; the claimed invention cannot be considered novel or cannot be considered to involve an inventive step when the document is taken alone "Y" document of particular relevance; the claimed invention cannot be considered to involve an inventive step when the document is combined with one or more other such documents, such combination being obvious to a person skilled in the art "&" document member of the same patent family
Date of the actual completion of the international search 27 MARCH 2012 (27.03.2012)		Date of mailing of the international search report 09 APRIL 2012 (09.04.2012)
Name and mailing address of the ISA/KR  Korean Intellectual Property Office Government Complex-Daejeon, 189 Cheongsa-ro, Seo-gu, Daejeon 302-701, Republic of Korea Facsimile No. 82-42-472-7140		Authorized officer JANG, GI JEONG Telephone No. 82-42-481-5498 

INTERNATIONAL SEARCH REPORT
Information on patent family members

International application No.
PCT/US2011/048316

Patent document cited in search report	Publication date	Patent family member(s)	Publication date
KR 10-1994-0011902 A	22.06.1994	None	
KR 10-2000-0059532 A	05.10.2000	None	
EP 0415747 A2	06.03.1991	CA 2024221 A1 CN 1050762 A EP 0415747 A3 JP 03-099150 A NZ235064A US 05058388A A	01.03.1991 17.04.1991 15.01.1992 24.04.1991 25.02.1993 22.10.1991
US 2008-0198549 A1	21.03.2008	AU 2007-207648 A1 CA 2637351 A1 CN 101385408 A EP 1974592 A2 JP 2009-524151 A KR 10-2008-0097200 A US 2007-0163748 A1 US 2007-0165377 A1 US 2007-0167125 A1 US 2009-0259343 A1 US 7365973 B2 WO 2007-084489 A2 WO 2007-084489 A3	26.07.2007 26.07.2007 11.03.2009 01.10.2008 25.06.2009 04.11.2008 19.07.2007 19.07.2007 19.07.2007 15.10.2009 29.04.2008 26.07.2007 26.07.2007

PATENT COOPERATION TREATY

From the INTERNATIONAL SEARCHING AUTHORITY

To:
 KING, JOHN, R.

 KNOBBE, MARTENS, OLSON & BEAR, LLP 2040 MAIN STREET, 14TH FLOOR IRVINE CA 92614 USA

PCT

NOTIFICATION OF TRANSMITTAL OF THE INTERNATIONAL SEARCH REPORT AND THE WRITTEN OPINION OF THE INTERNATIONAL SEARCHING AUTHORITY, OR THE DECLARATION

(PCT Rule 44.1)

Date of mailing (day/month/year) 06 undefined 2013 (06.08.2013)

Applicant's or agent's file reference
 EFACT014W0

FOR FURTHER ACTION See paragraphs 1 and 4 below

International application No.
PCT/US2013/035726

International filing date (day/month/year) **09 April 2013 (09.04.2013)**

Applicant
ECOFACOR, INC.

1. The applicant is hereby notified that the international search report and the written opinion of the International Searching Authority have been established and are transmitted herewith.

Filing of amendments and statement under Article 19:

The applicant is entitled, if he so wishes, to amend the claims of the international application (see Rule 46):

When? The time limit for filing such amendments is normally two months from the date of transmittal of the international search report.

Where? Directly to the International Bureau of WIPO, 34 chemin des Colombettes
 1211 Geneva 20, Switzerland, Facsimile No.: +41 22 338 82 70

For more detailed instructions, see PCT Applicant's Guide, International Phase, paragraphs 9.004 - 9.011.

2. The applicant is hereby notified that no international search report will be established and that the declaration under Article 17(2)(a) to that effect and the written opinion of the International Searching Authority are transmitted herewith.

3. **With regard to any protest** against payment of (an) additional fee(s) under Rule 40.2, the applicant is notified that:
 the protest together with the decision thereon has been transmitted to the International Bureau together with any request to forward the texts of both the protest and the decision thereon to the designated Offices.

no decision has been made yet on the protest; the applicant will be notified as soon as a decision is made.

4. Reminders

The applicant may submit comments on an informal basis on the written opinion of the International Searching Authority to the International Bureau. The International Bureau will send a copy of such comments to all designated Offices unless an international preliminary examination report has been or is to be established. Following the expiration of 30 months from the priority date, these comments will also be made available to the public.

Shortly after the expiration of **18 months** from the priority date, the international application will be published by the International Bureau. If the applicant wishes to avoid or postpone publication, a notice of withdrawal of the international application, or of the priority claim, must reach the International Bureau before the completion of the technical preparations for international publication (Rules 90bis.1 and 90bis.3).

Within **19 months** from the priority date, but only in respect of some designated Offices, a demand for international preliminary examination must be filed if the applicant wishes to postpone the entry into the national phase **until 30 months** from the priority date (in some Offices even later); otherwise, the applicant must, **within 20 months** from the priority date, perform the prescribed acts for entry into the national phase before those designated Offices.

In respect of other designated Offices, the time limit of **30 months** (or later) will apply even if no demand is filed within 19 months.

For details about the applicable time limits, Office by Office, see www.wipo.int/pct/en/texts/time_limits.html and the PCT Applicant's Guide, National Chapters.

Name and mailing address of the ISA/KR
 Korean Intellectual Property Office
 189 Cheongsa-ro, Seo-gu, Daejeon Metropolitan City, 302-701, Republic of Korea
 Facsimile No. 82-42-472-7140

Authorized officer
 COMMISSIONER
 Telephone No. 82-42-481-8753

DocScan Pro free trial

Received Orange County Docketing

AUG 18 2013

Knobbe, Martens, Olson & Bear LLP

DocScan Pro free trial

*** Attention**

Copies of the documents cited in the international search report can be searched in the following Korean Intellectual Property Office English website for three months from the date of mailing of the international search report.

<http://www.kipo.go.kr/en/> => PCT Services => PCT Services

ID : PCT international application number

PW : **HZE474K4**

Inquiries related to PCT International Search Report or Written Opinion prepared by KIPO as an International Searching Authority can be answered not only by KIPO but also through IPKC (Intellectual Property Korea Center), located in Vienna, VA, which functions as a PCT Help Desk for PCT applicants.

Homepage: <http://www.ipkcenter.com>

Email: ipkc@ipkcenter.com

PATENT COOPERATION TREATY

PCT

INTERNATIONAL SEARCH REPORT

(PCT Article 18 and Rules 43 and 44)

Applicant's or agent's file reference EFACT014WO	FOR FURTHER ACTION see Form PCT/ISA/220 as well as, where applicable, item 5 below.	
International application No. PCT/US2013/035726	International filing date (<i>day/month/year</i>) 09 April 2013 (09.04.2013)	(Earliest) Priority Date (<i>day/month/year</i>) 14 June 2012 (14.06.2012)
Applicant ECOFACOR, INC.		

This International search report has been prepared by this International Searching Authority and is transmitted to the applicant according to Article 18. A copy is being transmitted to the International Bureau.

This international search report consists of a total of 3 sheets.

It is also accompanied by a copy of each prior art document cited in this report.

1. **Basis of the report**

a. With regard to the **language**, the international search was carried out on the basis of:

- the international application in the language in which it was filed
- a translation of the international application into _____, which is the language of a translation furnished for the purposes of international search (Rules 12.3(a) and 23.1(b))

b. This international search report has been established taking into account the **rectification of an obvious mistake** authorized by or notified to this Authority under Rule 91 (Rule 43.6bis(a)).

c. With regard to any **nucleotide and/or amino acid sequence** disclosed in the international application, see Box No. I.

2. **Certain claims were found unsearchable** (See Box No. II)

3. **Unity of invention is lacking** (See Box No. III)

4. With regard to the **title**,

- the text is approved as submitted by the applicant.
- the text has been established by this Authority to read as follows:

5. With regard to the **abstract**,



- the text is approved as submitted by the applicant.
- the text has been established, according to Rule 38.2, by this Authority as it appears in Box No. IV. The applicant may, within one month from the date of mailing of this international search report, submit comments to this Authority.

6. With regard to the **drawings**,

- a. the figure of the **drawings** to be published with the abstract is Figure No. 2
 - as suggested by the applicant.
 - as selected by this Authority, because the applicant failed to suggest a figure.
 - as selected by this Authority, because this figure better characterizes the invention.
- b. none of the figure is to be published with the abstract.

INTERNATIONAL SEARCH REPORT

International application No.
PCT/US2013/035726

A. CLASSIFICATION OF SUBJECT MATTER F24F 11/02(2006.01)i, G05D 23/00(2006.01)i, G06Q 50/06(2012.01)i		
According to International Patent Classification (IPC) or to both national classification and IPC		
B. FIELDS SEARCHED		
Minimum documentation searched (classification system followed by classification symbols) F24F 11/02; F23N 1/00; F24F 5/00; G07F 15/08; G05D 23/00; G06Q 50/06		
Documentation searched other than minimum documentation to the extent that such documents are included in the fields searched Korean utility models and applications for utility models Japanese utility models and applications for utility models		
Electronic data base consulted during the international search (name of data base and, where practicable, search terms used) eKOMPASS(KIPO internal) & keywords: HVAC system, running cost, thermostat, and processor		
C. DOCUMENTS CONSIDERED TO BE RELEVANT		
Category*	Citation of document, with indication, where appropriate, of the relevant passages	Relevant to claim No.
A	JP 2010-286218 A (MITSUBISHI HEAVY IND. LTD.) 24 December 2010 See paragraphs [0021]-[0025] and figures 1,2.	1-18
A	KR 10-1999-0070368 A (SAMSUNG ELECTRONICS CO., LTD.) 15 September 1999 See abstract and figures 3,4.	1-18
A	JP 05-189659 A (HITACHI BILL SHISETSU ENG. KK.) 30 July 1993 See abstract and figure 1.	1-18
A	JP 2010-038377 A (MITSUBISHI HEAVY IND. LTD.) 18 February 2010 See abstract and figures 1,2.	1-18
A	US 6786421 B2 (ROSEN, HOWARD) 07 September 2004 See abstract and figure 1A.	1-18
<input type="checkbox"/> Further documents are listed in the continuation of Box C. <input checked="" type="checkbox"/> See patent family annex.		
* Special categories of cited documents: "A" document defining the general state of the art which is not considered to be of particular relevance "E" earlier application or patent but published on or after the international filing date "L" document which may throw doubts on priority claim(s) or which is cited to establish the publication date of citation or other special reason (as specified) "O" document referring to an oral disclosure, use, exhibition or other means "P" document published prior to the international filing date but later than the priority date claimed "T" later document published after the international filing date or priority date and not in conflict with the application but cited to understand the principle or theory underlying the invention "X" document of particular relevance; the claimed invention cannot be considered novel or cannot be considered to involve an inventive step when the document is taken alone "Y" document of particular relevance; the claimed invention cannot be considered to involve an inventive step when the document is combined with one or more other such documents, such combination being obvious to a person skilled in the art "&" document member of the same patent family		
Date of the actual completion of the international search 05 August 2013 (05.08.2013)		Date of mailing of the international search report 06 undefined 2013 (06.08.2013)
Name and mailing address of the ISA/KR  Korean Intellectual Property Office 189 Cheongsa-ro, Seo-gu, Daejeon Metropolitan City, 302-701, Republic of Korea Facsimile No. +82-42-472-7140		Authorized officer KIM Jin Ho  Telephone No. +82-42-481-8699

INTERNATIONAL SEARCH REPORT
Information on patent family members

International application No.
PCT/US2013/035726

Patent document cited in search report	Publication date	Patent family member(s)	Publication date
JP 2010-286218 A	24/12/2010	None	
KR 10-1999-0070368 A	15/09/1999	CN 1119579 C	27/08/2003
		CN 1226663 A	25/08/1999
		CN 1226663 C	25/08/1999
		JP 03011715 B2	21/02/2000
		JP 11-281122 A	15/10/1999
		US 6145328 A	14/11/2000
JP 05-189659 A	30/07/1993	JP 07001511 B2	11/01/1995
JP 2010-038377 A	18/02/2010	None	
US 6786421 B2	07/09/2004	US 2003-0142121 A1	31/07/2003
		US 2004-0074978 A1	22/04/2004
		US 6824069 B2	30/11/2004
		US 7152806 B1	26/12/2006

PATENT COOPERATION TREATY

From the
INTERNATIONAL SEARCHING AUTHORITY

To:
KING, JOHN, R.

KNOBBE, MARTENS, OLSON & BEAR, LLP 2040 MAIN STREET, 14TH FLOOR IRVINE CA 92614 USA

PCT
WRITTEN OPINION OF THE
INTERNATIONAL SEARCHING AUTHORITY
(PCT Rule 43bis.1)

Date of mailing
(day/month/year) **06 undefined 2013 (06.08.2013)**

Applicant's or agent's file reference EFACT014WO		FOR FURTHER ACTION See paragraph 2 below
International application No. PCT/US2013/035726	International filing date (day/month/year) 09 April 2013 (09.04.2013)	Priority date(day/month/year) 14 June 2012 (14.06.2012)
International Patent Classification (IPC) or both national classification and IPC F24F 11/02(2006.01)i, G05D 23/00(2006.01)i, G06Q 50/06(2012.01)i		
Applicant ECOFACOR, INC.		



1. This opinion contains indications relating to the following items:

- Box No. I Basis of the opinion
- Box No. II Priority
- Box No. III Non-establishment of opinion with regard to novelty, inventive step and industrial applicability
- Box No. IV Lack of unity of invention
- Box No. V Reasoned statement under Rule 43bis.1(a)(i) with regard to novelty, inventive step or industrial applicability; citations and explanations supporting such statement
- Box No. VI Certain documents cited
- Box No. VII Certain defects in the international application
- Box No. VIII Certain observations on the international application

2. FURTHER ACTION

If a demand for international preliminary examination is made, this opinion will be considered to be a written opinion of the International Preliminary Examining Authority ("IPEA") except that this does not apply where the applicant chooses an Authority other than this one to be the IPEA and the chosen IPEA has notified the International Bureau under Rule 66.1bis(b) that written opinions of this International Searching Authority will not be so considered.

If this opinion is, as provided above, considered to be a written opinion of the IPEA, the applicant is invited to submit to the IPEA a written reply together, where appropriate, with amendments, before the expiration of 3 months from the date of mailing of Form PCT/ISA/220 or before the expiration of 22 months from the priority date, whichever expires later.
For further options, see Form PCT/ISA/220.

 Name and mailing address of the ISA/KR Korean Intellectual Property Office 189 Cheongsa-ro, Seo-gu, Daejeon Metropolitan City, 302-701, Republic of Korea Facsimile No. +82-42-472-7140	Date of completion of this opinion 05 August 2013 (05.08.2013)	Authorized officer KIM Jin Ho Telephone No. +82-42-481-8699 
--	---	--

Form PCT/ISA/237 (cover sheet) (July 2011)

WRITTEN OPINION OF THE
INTERNATIONAL SEARCHING AUTHORITY

International application No.
PCT/US2013/035726

Box No. I Basis of this opinion

1. With regard to the **language**, this opinion has been established on the basis of :
 - the international application in the language in which it was filed
 - a translation of the international application into _____, which is the language of a translation furnished for the purposes of international search (Rules 12.3(a) and 23.1(b))
2. This opinion has been established taking into account the **rectification of an obvious mistake** authorized by or notified to this Authority under Rule 91 (Rule 43bis.1(a))
3. With regard to any **nucleotide and/or amino acid sequence** disclosed in the international application, this opinion has been established on the basis of:
 - a. a sequence listing filed or furnished
 - on paper
 - in electronic form
 - b. time of filing or furnishing
 - contained in the international application as filed.
 - filed together with the international application in electronic form.
 - furnished subsequently to this Authority for the purposes of search.
4. In addition, in the case that more than one version or copy of a sequence listing has been filed or furnished, the required statements that the information in the subsequent or additional copies is identical to that in the application as filed or does not go beyond the application as filed, as appropriate, were furnished.
5. Additional comments:

**WRITTEN OPINION OF THE
INTERNATIONAL SEARCHING AUTHORITY**

International application No.
PCT/US2013/035726

Box No. V Reasoned statement under Rule 43bis.1(a)(i) with regard to novelty, inventive step or industrial applicability; citations and explanations supporting such statement

1. Statement

Novelty (N)	Claims	<u>1-18</u>	YES
	Claims	<u>NONE</u>	NO
Inventive step (IS)	Claims	<u>1-18</u>	YES
	Claims	<u>NONE</u>	NO
Industrial applicability (IA)	Claims	<u>1-18</u>	YES
	Claims	<u>NONE</u>	NO

2. Citations and explanations :

Reference is made to the following documents:

- D1: JP 2010-286218 A (MITSUBISHI HEAVY IND. LTD.) 24 December 2010
- D2: KR 10-1999-0070368 A (SAMSUNG ELECTRONICS CO., LTD.) 15 September 1999
- D3: JP 05-189659 A (HITACHI BILL SHISETSU ENG. KK.) 30 July 1993
- D4: JP 2010-038377 A (MITSUBISHI HEAVY IND. LTD.) 18 February 2010
- D5: S 6786421 B2 (ROSEN, HOWARD) 07 September 2004

1. Novelty and Inventive Step

1.1 Independent claim 1

None of the documents D1-D5 teach or fairly suggest a system for allocating the cost of operating an HVAC system comprising a thermostatic controller configured to turn on or off a first component associated with an individual unit of occupancy based on temperature reading from an inside of the individual unit of occupancy. Accordingly, claim 1 is not anticipated by any of the documents, nor is it obvious to a person skilled in the art by the documents, taken alone or in combination. Therefore, claim 1 is novel and involves an inventive step under PCT Article 33(2) and (3).

1.2 Dependent claims 2-9

Claims 2-9 are directly or indirectly dependent on claim 1 and therefore meet the requirements of PCT Article 33(2) and (3).

Continued on Supplemental Box

**WRITTEN OPINION OF THE
INTERNATIONAL SEARCHING AUTHORITY**

International application No.

PCT/US2013/035726

Supplemental Box

In case the space in any of the preceding boxes is not sufficient.
Continuation of: Box No. V

1.3 Independent claim 10

Claim 10 concerns a method for allocating the cost of operating an HVAC system, but it has the same technical features as claim 1. Thus, the same reasoning applies to claim 10. Therefore, claim 10 is novel and involves an inventive step under PCT Article 33(2) and (3).

1.4 Dependent claims 11-18

Claims 11-18 are directly or indirectly dependent on claim 10 and therefore meet the requirements of PCT Article 33(2) and (3).

2. Industrial Applicability

Claims 1-18 meet the requirement of industrial applicability under PCT Article 33(4).

IN THE UNITED STATES PATENT AND TRADEMARK OFFICE

Inventor	:	John Douglas Steinberg, et al.
App. No.	:	12/778,052
Filed	:	May 11, 2010
For	:	SYSTEM, METHOD AND APPARATUS FOR IDENTIFYING MANUAL INPUTS TO AND ADAPTIVE PROGRAMMING OF A THERMOSTAT
Examiner	:	Norman, Marc E.
Art Unit	:	3744
Conf No.	:	5650

RESPONSE TO NOTICE TO FILE CORRECTED APPLICATION PAPERS**Mail Stop Amendment**

Commissioner for Patents
P.O. Box 1450
Alexandria, VA 22313-1450

Dear Sir:

In response to the Notice to File Corrected Application Papers mailed October 28, 2013, Applicant respectfully submits the following amendments and comments.

Amendments to the Specification are reflected in the listing of claims which begins on page 3 of this paper.

Remarks/Arguments begin on page 8 of this paper.

Application No.: 12/778,052
Filing Date: May 11, 2010

AMENDMENTS TO THE SPECIFICATION

The drawings filed on August 20, 2010 include a Fig. 10 but the specification's brief description of the drawings does not describe a drawing with that designation. Applicant hereby amends the specification as follows:

After paragraph 0015 please insert:

"Figure 10 shows an example of some of the contextual data that may be used by the server in order to interpret manual overrides. "

AMENDMENTS TO THE CLAIMS

No amendments have been made to the Claims.

1. (Previously Presented) A method for detecting manual changes to the setpoint for a thermostatic controller comprising:

accessing stored data comprising a plurality of internal temperature measurements taken within a structure and a plurality of outside temperature measurements relating to temperatures outside the structure;

using the stored data to predict a rate of change of temperatures inside the structure in response to at least changes in outside temperatures;

calculating with one or more computer processors, scheduled programming of the thermostatic controller for one or more times based on the predicted rate of change, the scheduled programming comprising at least a first automated setpoint at a first time;

generating with one or more computer processors, a difference value based on comparing an actual setpoint at the first time for said thermostatic controller to the first automated setpoint for said thermostatic controller;

detecting a manual change to the first automated setpoint by determining whether said actual setpoint and said first automated setpoint are the same or different based on said difference value; and

logging said manual change to a database associated with the thermostatic controller.

2. (Original) A method as in Claim 1 where said thermostatic controller operates a system for changing the air temperature in a structure.

3. (Original) A method as in Claim 1 where said thermostatic controller operates a heating, ventilation and air conditioning system.

Application No.: 12/778,052
Filing Date: May 11, 2010

4. (Original) A method as in Claim 1 where said thermostatic controller operates a heating, ventilation and air conditioning system in a single family residence.

5. (Original) A method as in Claim 1 in which at least one remote processor is in communication with said thermostatic control device.

6. (Original) A method as in Claim 5 in which said remote processor is not located in the same structure as said thermostatic controller.

7. (Original) A method as in Claim 5 in which said remote processor sets programming for said thermostatic controller.

8. (Original) A method as in Claim 1 in which said thermostatic controller is programmable.

9. (Previously Presented) A method for incorporating manual changes to the setpoint for a thermostatic controller into long-term programming of said thermostatic controller comprising:

accessing stored data comprising a plurality of internal temperature measurements taken within a structure and a plurality of outside temperature measurements relating to temperatures outside the structure;

using the stored data to predict a rate of change of temperatures inside the structure in response to at least changes in outside temperatures;

calculating scheduled programming of setpoints in the thermostatic controller based on the predicted rate of change, the scheduled programming comprising at least a first automated setpoint at a first time and a second automated setpoint at a second time;

comparing the actual setpoint at the first time for said thermostatic controller to the first automated setpoint for said thermostatic controller ;

detecting a manual change to the first automated setpoint by determining whether said actual setpoint and said first automated setpoint are the same or different;

Application No.: 12/778,052
Filing Date: May 11, 2010

changing the second automated setpoint at the second time based on at least one rule for the interpretation of said manual change.

10. (Original) A method as in Claim 9 where said thermostatic controller operates a system for changing the air temperature in a structure.

11. (Original) A method as in Claim 9 where said thermostatic controller operates a heating, ventilation and air conditioning system.

12. (Original) A method as in Claim 9 where said thermostatic controller operates a heating, ventilation and air conditioning system in a single family residence.

13. (Original) A method as in Claim 9 in which at least one remote processor is in communication with said thermostatic control device.

14. (Original) A method as in Claim 13 in which said remote processor is not located in the same structure as said thermostatic controller.

15. (Original) A method as in Claim 13 in which said remote processor sets programming for said thermostatic controller.

16. (Original) A system as in Claim 9 in which said thermostatic controller is programmable.

17. (Previously Presented) An apparatus for detecting manual changes to the setpoint for a thermostatic controller comprising:

at least a programmable communicating thermostat;

at least a remote processor;

at least a network connecting said remote processor and said communicating;

at least a database comprising a plurality of internal temperature measurements taken within a structure and a plurality of outside temperature measurements relating to temperatures outside the structure;

Application No.: 12/778,052
Filing Date: May 11, 2010

computer hardware comprising one or more computer processors configured to use the stored data to predict a rate of change of temperatures inside the structure in response to changes in outside temperatures;

the one or more computer processors configured to calculate scheduled setpoint programming of the programmable communicating thermostat for one or more times based on the predicted rate of change, the scheduled programming comprising one or more automated setpoints;

at least a database that stores the one or more automated setpoints associated with the scheduled programming for said programmable communicating thermostat;

at least a database that stores actual setpoint programming of said programmable communicating thermostat; and

the one or more computer processors configured to compare the one or more automated setpoints associated with said scheduled setpoint programming with said actual setpoint programming.

18. (Original) An apparatus as in claim 17 where said programmable communicating thermostat operates a system for changing the air temperature in a structure.

19. (Original) An apparatus as in claim 17 where said programmable communicating thermostat operates a heating, ventilation and air conditioning system.

20. (Original) An apparatus as in claim 17 where said programmable communicating thermostat operates a heating, ventilation and air conditioning system in a single family residence.

21. (Original) An apparatus as in claim 20 in which at least one remote processor is in communication with said programmable communicating thermostat.

22. (Original) An apparatus as in claim 20 in which said remote processor is not located in the same structure as said programmable communicating thermostat.

Application No.: 12/778,052
Filing Date: May 11, 2010

23. (Original) An apparatus as in claim 20 in which said remote processor sets programming for said programmable communicating thermostat.

Application No.: 12/778,052
Filing Date: May 11, 2010

REMARKS

The drawings filed on August 20, 2010 include a Fig. 10 but the specification's brief description of the drawings does not describe a drawing with that designation.

Applicant notes that paragraph 0043 of the patent application refers to Figure 10. Accordingly, Applicant has used the language in paragraph 0043 for the summary of Figure 10 in the Brief Description of the Drawings.

After paragraph 0015 of the application, please insert:

"Figure 10 shows an example of some of the contextual data that may be used by the server in order to interpret manual overrides. "

Applicant respectfully submits that no new matter is being introduced by way of this amendment to the specification and requests that the foregoing amendment to the specification be entered and made of record.

Please charge any additional fees, including any fees for additional extension of time, or credit overpayment to Deposit Account No. 11-1410.

Respectfully submitted,

KNOBBE, MARTENS, OLSON & BEAR, LLP

Dated: 10-30-2013

By: John R. King
John R. King
Registration No. 34,362
Attorney of Record
Customer No. 20995
(949) 760-0404

16564951:ad
102913



UNITED STATES PATENT AND TRADEMARK OFFICE

UNITED STATES DEPARTMENT OF COMMERCE
United States Patent and Trademark Office
Address: COMMISSIONER FOR PATENTS
P.O. Box 1450
Alexandria, Virginia 22313-1450
www.uspto.gov

APPLICATION NO.	FILING DATE	FIRST NAMED INVENTOR	ATTORNEY DOCKET NO.	CONFIRMATION NO.
12/778,052	05/11/2010	John Douglas Steinberg	EFACT.007A	5650
20995	7590	10/28/2013	EXAMINER	
KNOBBE MARTENS OLSON & BEAR LLP			NORMAN, MARC E	
2040 MAIN STREET			ART UNIT	PAPER NUMBER
FOURTEENTH FLOOR			3744	
IRVINE, CA 92614			NOTIFICATION DATE	DELIVERY MODE
			10/28/2013	ELECTRONIC

Please find below and/or attached an Office communication concerning this application or proceeding.

The time period for reply, if any, is set in the attached communication.

Notice of the Office communication was sent electronically on above-indicated "Notification Date" to the following e-mail address(es):

jayna.cartee@knobbe.com
efiling@knobbe.com



UNITED STATES PATENT AND TRADEMARK OFFICE

Commissioner for Patents
United States Patent and Trademark Office
P.O. Box 1450
Alexandria, VA 22313-1450
www.uspto.gov

Application No. : 12778052
Applicant : Steinberg
Filing Date : 05/11/2010
Date Mailed : 10/28/2013

NOTICE TO FILE CORRECTED APPLICATION PAPERS

Notice of Allowance Mailed

This application has been accorded an Allowance Date and is being prepared for issuance. The application, however, is incomplete for the reasons below.

Applicant is given 2 month(s) from the mail date of this Notice, or the time remaining from the Notice of Allowance and Fee(s) Due, whichever is longer, within which to respond.

The informalities requiring correction are indicated in the attachment(s). If the informality pertains to the abstract, specification (including claims) or drawings, the informality must be corrected with an amendment in compliance with 37 CFR 1.121 (or, if the application is a reissue application, 37 CFR 1.173). Such an amendment may be filed after payment of the issue fee if limited to correction of informalities noted herein. See Waiver of 37 CFR 1.312 for Documents Required by the Office of Patent Publication, 1280 Off. Gaz. Patent Office 918 (March 23, 2004). In addition, if the informality is not corrected until after payment of the issue fee, for purposes of 35 U.S.C. 154(b)(1)(iv), "all outstanding requirements" will be considered to have been satisfied when the informality has been corrected. A failure to respond within the above-identified time period will result in the application being ABANDONED. **This period for reply is NOT extendable under 37 CFR 1.136(a).**

See attachment(s).

*A copy of this notice **MUST** be returned with the reply. Please address response to "Mail Stop Issue Fee, Commissioner for Patents, P.O. Box 1450, Alexandria, VA 22313-1450".*

/Anthony McPhail/
Publication Branch
Office of Data Management
(571) 272-4200

Application No. 12778052

IDENTIFICATION OF SPECIFICATION/DRAWING INCONSISTENCIES

- On Page of the specification there is a brief description of FIG. , but the drawings filed do not include a drawing with that designation. Applicant must respond either by supplying the omitted drawing or by amending the specification to remove all references to that drawing.
- The drawings filed 08/20/2010 include FIG. 10, but the specification's brief description of the drawings does not describe a drawing with that designation. Applicant must respond either by amending the specification to add a brief description of that drawing or by correcting the drawings to remove the drawing in question.
- Drawings are present in the application and are referred to in the detailed description of the invention, but the specification does not contain a brief description of the drawings as required by 37 CFR 1.74 and 37 CFR 1.77(b)(8).
- Page of the specification refers to FIG. , but no drawing with that designation is described in the brief description of the drawings and no drawing with that designation is present in the application. Applicant must respond either by amending the specification to remove all references to that drawing, or by supplying that drawing and amending the specification to add a brief description of it.
- OTHER:
- COMMENTS:

Electronic Patent Application Fee Transmittal

Application Number:	12778052			
Filing Date:	11-May-2010			
Title of Invention:	SYSTEM, METHOD AND APPARATUS FOR IDENTIFYING MANUAL INPUTS TO AND ADAPTIVE PROGRAMMING OF A THERMOSTAT			
First Named Inventor/Applicant Name:	John Douglas Steinberg			
Filer:	John R. King/Amy Durrant			
Attorney Docket Number:	EFACT.007A			
Filed as Small Entity				
Utility under 35 USC 111(a) Filing Fees				
Description	Fee Code	Quantity	Amount	Sub-Total in USD(\$)
Basic Filing:				
Pages:				
Claims:				
Miscellaneous-Filing:				
Petition:				
Patent-Appeals-and-Interference:				
Post-Allowance-and-Post-Issuance:				
Utility Appl Issue Fee	2501	1	890	890
Publ. Fee- Early, Voluntary, or Normal	1504	1	300	300

Description	Fee Code	Quantity	Amount	Sub-Total in USD(\$)
Extension-of-Time:				
Miscellaneous:				
Total in USD (\$)				1190

Electronic Acknowledgement Receipt

EFS ID:	17269188
Application Number:	12778052
International Application Number:	
Confirmation Number:	5650
Title of Invention:	SYSTEM, METHOD AND APPARATUS FOR IDENTIFYING MANUAL INPUTS TO AND ADAPTIVE PROGRAMMING OF A THERMOSTAT
First Named Inventor/Applicant Name:	John Douglas Steinberg
Customer Number:	20995
Filer:	John R. King/Sandra Autry
Filer Authorized By:	John R. King
Attorney Docket Number:	EFACT.007A
Receipt Date:	30-OCT-2013
Filing Date:	11-MAY-2010
Time Stamp:	16:57:18
Application Type:	Utility under 35 USC 111(a)

Payment information:

Submitted with Payment	yes
Payment Type	Credit Card
Payment was successfully received in RAM	\$ 1190
RAM confirmation Number	4641
Deposit Account	111410
Authorized User	KNOBBE MARTENS OLSON AND BEAR

The Director of the USPTO is hereby authorized to charge indicated fees and credit any overpayment as follows:

Charge any Additional Fees required under 37 C.F.R. Section 1.16 (National application filing, search, and examination fees)

Charge any Additional Fees required under 37 C.F.R. Section 1.17 (Patent application and reexamination processing fees)

File Listing:					
Document Number	Document Description	File Name	File Size(Bytes)/ Message Digest	Multi Part /.zip	Pages (if appl.)
1	Issue Fee Payment (PTO-85B)	EFACT-007A_issuefee.pdf	125537	no	2
			c6c5b4cb21250f1becaed9011be497678ee e7b8e		
Warnings:					
Information:					
2	Miscellaneous Incoming Letter	EFACT-007A_comments.pdf	40623	no	1
			86a5ab0a9d6b416f65f28ede6e85a277948 16d6		
Warnings:					
Information:					
3		EFACT-007A_ids.pdf	95256	yes	2
			14238927d8f50483d210c517c5d5542574b bfcc		
Multipart Description/PDF files in .zip description					
Document Description			Start	End	
Transmittal Letter			1	1	
Information Disclosure Statement (IDS) Form (SB08)			2	2	
Warnings:					
Information:					
4	Foreign Reference	EFACT-007A_REF5.pdf	627787	no	9
			1b4a135d0fda728b281671c2d7d3a171001 7abe0		
Warnings:					
Information:					
5	Foreign Reference	EFACT-007A_REF6.pdf	432498	no	9
			c7753506d844727cae178f6f06aff335eba1c 251		
Warnings:					
Information:					
6	Foreign Reference	EFACT-007A_REF7.pdf	283229	no	10
			fa5d931b6d7cb60134f04e7da637a4ac9f52 757e		
Warnings:					
Information:					
7	Foreign Reference	EFACT-007A_REF8.pdf	172615	no	2
			a15039d16907cf93e78030b6b8d7d7c3685 6c017		
Warnings:					
Information:					

8	Foreign Reference	EFACT-007A_REF9.pdf	170927	no	5
			4fd1d0bb2f03cb935312be5c298eb1f44991161b		
Warnings:					
Information:					
9	Foreign Reference	EFACT-007A_REF10.pdf	143797	no	3
			b91caa11fecff2b1759bdae808782357a5bf88		
Warnings:					
Information:					
10	Non Patent Literature	EFACT-007A_REF11.pdf	349730	no	10
			b8461174e3efa0ce5429fecfedbc8879b4cc886		
Warnings:					
Information:					
11		EFACT-007A_Response.pdf	256524	yes	8
			bda3a2a40e4d662dff99a8837f93d60d640dbb33		
	Multipart Description/PDF files in .zip description				
	Document Description		Start	End	
	Applicant Response to Pre-Exam Formalities Notice		1	1	
	Specification		2	7	
	Applicant Arguments/Remarks Made in an Amendment		8	8	
Warnings:					
Information:					
12	Miscellaneous Incoming Letter	EFACT-007A_NOTICE.pdf	101655	no	3
			4f11cbb5cc7fc44c96984acd8754cc0a79fc39		
Warnings:					
Information:					
13	Fee Worksheet (SB06)	fee-info.pdf	31853	no	2
			ecca681c29f7987b9674859cd9e689c505f43d78		
Warnings:					
Information:					
Total Files Size (in bytes):			2832031		

This Acknowledgement Receipt evidences receipt on the noted date by the USPTO of the indicated documents, characterized by the applicant, and including page counts, where applicable. It serves as evidence of receipt similar to a Post Card, as described in MPEP 503.

New Applications Under 35 U.S.C. 111

If a new application is being filed and the application includes the necessary components for a filing date (see 37 CFR 1.53(b)-(d) and MPEP 506), a Filing Receipt (37 CFR 1.54) will be issued in due course and the date shown on this Acknowledgement Receipt will establish the filing date of the application.

National Stage of an International Application under 35 U.S.C. 371

If a timely submission to enter the national stage of an international application is compliant with the conditions of 35 U.S.C. 371 and other applicable requirements a Form PCT/DO/EO/903 indicating acceptance of the application as a national stage submission under 35 U.S.C. 371 will be issued in addition to the Filing Receipt, in due course.

New International Application Filed with the USPTO as a Receiving Office

If a new international application is being filed and the international application includes the necessary components for an international filing date (see PCT Article 11 and MPEP 1810), a Notification of the International Application Number and of the International Filing Date (Form PCT/RO/105) will be issued in due course, subject to prescriptions concerning national security, and the date shown on this Acknowledgement Receipt will establish the international filing date of the application.



UNITED STATES PATENT AND TRADEMARK OFFICE

UNITED STATES DEPARTMENT OF COMMERCE
United States Patent and Trademark Office
Address: COMMISSIONER FOR PATENTS
P.O. Box 1450
Alexandria, Virginia 22313-1450
www.uspto.gov

APPLICATION NO.	FILING DATE	FIRST NAMED INVENTOR	ATTORNEY DOCKET NO.	CONFIRMATION NO.
12/778,052	05/11/2010	John Douglas Steinberg	EFACT.007A	5650
20995	7590	10/28/2013	EXAMINER	
KNOBBE MARTENS OLSON & BEAR LLP			NORMAN, MARC E	
2040 MAIN STREET			ART UNIT	PAPER NUMBER
FOURTEENTH FLOOR			3744	
IRVINE, CA 92614			NOTIFICATION DATE	DELIVERY MODE
			10/28/2013	ELECTRONIC

Please find below and/or attached an Office communication concerning this application or proceeding.

The time period for reply, if any, is set in the attached communication.

Notice of the Office communication was sent electronically on above-indicated "Notification Date" to the following e-mail address(es):

jayna.cartee@knobbe.com
efiling@knobbe.com



UNITED STATES PATENT AND TRADEMARK OFFICE

Commissioner for Patents
United States Patent and Trademark Office
P.O. Box 1450
Alexandria, VA 22313-1450
www.uspto.gov

Application No. : 12778052
Applicant : Steinberg
Filing Date : 05/11/2010
Date Mailed : 10/28/2013

NOTICE TO FILE CORRECTED APPLICATION PAPERS

Notice of Allowance Mailed

This application has been accorded an Allowance Date and is being prepared for issuance. The application, however, is incomplete for the reasons below.

Applicant is given 2 month(s) from the mail date of this Notice, or the time remaining from the Notice of Allowance and Fee(s) Due, whichever is longer, within which to respond.

The informalities requiring correction are indicated in the attachment(s). If the informality pertains to the abstract, specification (including claims) or drawings, the informality must be corrected with an amendment in compliance with 37 CFR 1.121 (or, if the application is a reissue application, 37 CFR 1.173). Such an amendment may be filed after payment of the issue fee if limited to correction of informalities noted herein. See Waiver of 37 CFR 1.312 for Documents Required by the Office of Patent Publication, 1280 Off. Gaz. Patent Office 918 (March 23, 2004). In addition, if the informality is not corrected until after payment of the issue fee, for purposes of 35 U.S.C. 154(b)(1)(iv), "all outstanding requirements" will be considered to have been satisfied when the informality has been corrected. A failure to respond within the above-identified time period will result in the application being ABANDONED. **This period for reply is NOT extendable under 37 CFR 1.136(a).**

See attachment(s).

*A copy of this notice **MUST** be returned with the reply. Please address response to "Mail Stop Issue Fee, Commissioner for Patents, P.O. Box 1450, Alexandria, VA 22313-1450".*

/Anthony McPhail/
Publication Branch
Office of Data Management
(571) 272-4200

Application No. 12778052

IDENTIFICATION OF SPECIFICATION/DRAWING INCONSISTENCIES

- On Page of the specification there is a brief description of FIG. , but the drawings filed do not include a drawing with that designation. Applicant must respond either by supplying the omitted drawing or by amending the specification to remove all references to that drawing.
- The drawings filed 08/20/2010 include FIG. 10, but the specification's brief description of the drawings does not describe a drawing with that designation. Applicant must respond either by amending the specification to add a brief description of that drawing or by correcting the drawings to remove the drawing in question.
- Drawings are present in the application and are referred to in the detailed description of the invention, but the specification does not contain a brief description of the drawings as required by 37 CFR 1.74 and 37 CFR 1.77(b)(8).
- Page of the specification refers to FIG. , but no drawing with that designation is described in the brief description of the drawings and no drawing with that designation is present in the application. Applicant must respond either by amending the specification to remove all references to that drawing, or by supplying that drawing and amending the specification to add a brief description of it.
- OTHER:
- COMMENTS:



UNITED STATES PATENT AND TRADEMARK OFFICE

UNITED STATES DEPARTMENT OF COMMERCE
United States Patent and Trademark Office
Address: COMMISSIONER FOR PATENTS
P.O. Box 1450
Alexandria, Virginia 22313-1450
www.uspto.gov

NOTICE OF ALLOWANCE AND FEE(S) DUE

20995 7590 07/31/2013
KNOBBE MARTENS OLSON & BEAR LLP
2040 MAIN STREET
FOURTEENTH FLOOR
IRVINE, CA 92614

EXAMINER
NORMAN, MARC E

ART UNIT PAPER NUMBER

3744

DATE MAILED: 07/31/2013

Table with 5 columns: APPLICATION NO., FILING DATE, FIRST NAMED INVENTOR, ATTORNEY DOCKET NO., CONFIRMATION NO.
12/778,052 05/11/2010 John Douglas Steinberg EFACT.007A 5650

TITLE OF INVENTION: SYSTEM, METHOD AND APPARATUS FOR IDENTIFYING MANUAL INPUTS TO AND ADAPTIVE PROGRAMMING OF A THERMOSTAT

Table with 7 columns: APPLN. TYPE, ENTITY STATUS, ISSUE FEE DUE, PUBLICATION FEE DUE, PREV. PAID ISSUE FEE, TOTAL FEE(S) DUE, DATE DUE
nonprovisional SMALL \$890 \$300 \$0 \$1190 10/31/2013

THE APPLICATION IDENTIFIED ABOVE HAS BEEN EXAMINED AND IS ALLOWED FOR ISSUANCE AS A PATENT. PROSECUTION ON THE MERITS IS CLOSED. THIS NOTICE OF ALLOWANCE IS NOT A GRANT OF PATENT RIGHTS. THIS APPLICATION IS SUBJECT TO WITHDRAWAL FROM ISSUE AT THE INITIATIVE OF THE OFFICE OR UPON PETITION BY THE APPLICANT. SEE 37 CFR 1.313 AND MPEP 1308.

THE ISSUE FEE AND PUBLICATION FEE (IF REQUIRED) MUST BE PAID WITHIN THREE MONTHS FROM THE MAILING DATE OF THIS NOTICE OR THIS APPLICATION SHALL BE REGARDED AS ABANDONED. THIS STATUTORY PERIOD CANNOT BE EXTENDED. SEE 35 U.S.C. 151. THE ISSUE FEE DUE INDICATED ABOVE DOES NOT REFLECT A CREDIT FOR ANY PREVIOUSLY PAID ISSUE FEE IN THIS APPLICATION. IF AN ISSUE FEE HAS PREVIOUSLY BEEN PAID IN THIS APPLICATION (AS SHOWN ABOVE), THE RETURN OF PART B OF THIS FORM WILL BE CONSIDERED A REQUEST TO REAPPLY THE PREVIOUSLY PAID ISSUE FEE TOWARD THE ISSUE FEE NOW DUE.

HOW TO REPLY TO THIS NOTICE:

I. Review the ENTITY STATUS shown above. If the ENTITY STATUS is shown as SMALL or MICRO, verify whether entitlement to that entity status still applies.

If the ENTITY STATUS is the same as shown above, pay the TOTAL FEE(S) DUE shown above.

If the ENTITY STATUS is changed from that shown above, on PART B - FEE(S) TRANSMITTAL, complete section number 5 titled "Change in Entity Status (from status indicated above)".

For purposes of this notice, small entity fees are 1/2 the amount of undiscounted fees, and micro entity fees are 1/2 the amount of small entity fees.

II. PART B - FEE(S) TRANSMITTAL, or its equivalent, must be completed and returned to the United States Patent and Trademark Office (USPTO) with your ISSUE FEE and PUBLICATION FEE (if required). If you are charging the fee(s) to your deposit account, section "4b" of Part B - Fee(s) Transmittal should be completed and an extra copy of the form should be submitted. If an equivalent of Part B is filed, a request to reapply a previously paid issue fee must be clearly made, and delays in processing may occur due to the difficulty in recognizing the paper as an equivalent of Part B.

III. All communications regarding this application must give the application number. Please direct all communications prior to issuance to Mail Stop ISSUE FEE unless advised to the contrary.

IMPORTANT REMINDER: Utility patents issuing on applications filed on or after Dec. 12, 1980 may require payment of maintenance fees. It is patentee's responsibility to ensure timely payment of maintenance fees when due.

PART B - FEE(S) TRANSMITTAL

**Complete and send this form, together with applicable fee(s), to: Mail Mail Stop ISSUE FEE
 Commissioner for Patents
 P.O. Box 1450
 Alexandria, Virginia 22313-1450
 or Fax (571)-273-2885**

INSTRUCTIONS: This form should be used for transmitting the ISSUE FEE and PUBLICATION FEE (if required). Blocks 1 through 5 should be completed where appropriate. All further correspondence including the Patent, advance orders and notification of maintenance fees will be mailed to the current correspondence address as indicated unless corrected below or directed otherwise in Block 1, by (a) specifying a new correspondence address; and/or (b) indicating a separate "FEE ADDRESS" for maintenance fee notifications.

CURRENT CORRESPONDENCE ADDRESS (Note: Use Block 1 for any change of address)

20995 7590 07/31/2013
KNOBBE MARTENS OLSON & BEAR LLP
 2040 MAIN STREET
 FOURTEENTH FLOOR
 IRVINE, CA 92614

Note: A certificate of mailing can only be used for domestic mailings of the Fee(s) Transmittal. This certificate cannot be used for any other accompanying papers. Each additional paper, such as an assignment or formal drawing, must have its own certificate of mailing or transmission.

Certificate of Mailing or Transmission

I hereby certify that this Fee(s) Transmittal is being deposited with the United States Postal Service with sufficient postage for first class mail in an envelope addressed to the Mail Stop ISSUE FEE address above, or being facsimile transmitted to the USPTO (571) 273-2885, on the date indicated below.

_____ (Depositor's name)
_____ (Signature)
_____ (Date)

APPLICATION NO.	FILING DATE	FIRST NAMED INVENTOR	ATTORNEY DOCKET NO.	CONFIRMATION NO.
12/778,052	05/11/2010	John Douglas Steinberg	EFACT.007A	5650

TITLE OF INVENTION: SYSTEM, METHOD AND APPARATUS FOR IDENTIFYING MANUAL INPUTS TO AND ADAPTIVE PROGRAMMING OF A THERMOSTAT

APPLN. TYPE	ENTITY STATUS	ISSUE FEE DUE	PUBLICATION FEE DUE	PREV. PAID ISSUE FEE	TOTAL FEE(S) DUE	DATE DUE
nonprovisional	SMALL	\$890	\$300	\$0	\$1190	10/31/2013

EXAMINER	ART UNIT	CLASS-SUBCLASS
NORMAN, MARC E	3744	236-051000

1. Change of correspondence address or indication of "Fee Address" (37 CFR 1.363).
 Change of correspondence address (or Change of Correspondence Address form PTO/SB/122) attached.
 "Fee Address" indication (or "Fee Address" Indication form PTO/SB/47; Rev 03-02 or more recent) attached. **Use of a Customer Number is required.**

2. For printing on the patent front page, list
 (1) the names of up to 3 registered patent attorneys or agents OR, alternatively, 1 _____
 (2) the name of a single firm (having as a member a registered attorney or agent) and the names of up to 2 registered patent attorneys or agents. If no name is listed, no name will be printed. 2 _____
 3 _____

3. ASSIGNEE NAME AND RESIDENCE DATA TO BE PRINTED ON THE PATENT (print or type)

PLEASE NOTE: Unless an assignee is identified below, no assignee data will appear on the patent. If an assignee is identified below, the document has been filed for recordation as set forth in 37 CFR 3.11. Completion of this form is NOT a substitute for filing an assignment.

(A) NAME OF ASSIGNEE _____ (B) RESIDENCE: (CITY and STATE OR COUNTRY) _____

Please check the appropriate assignee category or categories (will not be printed on the patent): Individual Corporation or other private group entity Government

4a. The following fee(s) are submitted:
 Issue Fee
 Publication Fee (No small entity discount permitted)
 Advance Order - # of Copies _____

4b. Payment of Fee(s): (Please first reapply any previously paid issue fee shown above)
 A check is enclosed.
 Payment by credit card. Form PTO-2038 is attached.
 The Director is hereby authorized to charge the required fee(s), any deficiency, or credit any overpayment, to Deposit Account Number _____ (enclose an extra copy of this form).

5. **Change in Entity Status** (from status indicated above)

Applicant certifying micro entity status. See 37 CFR 1.29

NOTE: Absent a valid certification of Micro Entity Status (see form PTO/SB/15A and 15B), issue fee payment in the micro entity amount will not be accepted at the risk of application abandonment.

Applicant asserting small entity status. See 37 CFR 1.27

NOTE: If the application was previously under micro entity status, checking this box will be taken to be a notification of loss of entitlement to micro entity status.

Applicant changing to regular undiscounted fee status.

NOTE: Checking this box will be taken to be a notification of loss of entitlement to small or micro entity status, as applicable.

NOTE: The Issue Fee and Publication Fee (if required) will not be accepted from anyone other than the applicant; a registered attorney or agent; or the assignee or other party in interest as shown by the records of the United States Patent and Trademark Office.

Authorized Signature _____

Date _____

Typed or printed name _____

Registration No. _____

This collection of information is required by 37 CFR 1.311. The information is required to obtain or retain a benefit by the public which is to file (and by the USPTO to process) an application. Confidentiality is governed by 35 U.S.C. 122 and 37 CFR 1.14. This collection is estimated to take 12 minutes to complete, including gathering, preparing, and submitting the completed application form to the USPTO. Time will vary depending upon the individual case. Any comments on the amount of time you require to complete this form and/or suggestions for reducing this burden, should be sent to the Chief Information Officer, U.S. Patent and Trademark Office, U.S. Department of Commerce, P.O. Box 1450, Alexandria, Virginia 22313-1450. DO NOT SEND FEES OR COMPLETED FORMS TO THIS ADDRESS. SEND TO: Commissioner for Patents, P.O. Box 1450, Alexandria, Virginia 22313-1450.

Under the Paperwork Reduction Act of 1995, no persons are required to respond to a collection of information unless it displays a valid OMB control number.



UNITED STATES PATENT AND TRADEMARK OFFICE

UNITED STATES DEPARTMENT OF COMMERCE
United States Patent and Trademark Office
Address: COMMISSIONER FOR PATENTS
P.O. Box 1450
Alexandria, Virginia 22313-1450
www.uspto.gov

Table with columns: APPLICATION NO., FILING DATE, FIRST NAMED INVENTOR, ATTORNEY DOCKET NO., CONFIRMATION NO., EXAMINER, ART UNIT, PAPER NUMBER. Includes application details for 12/778,052 and examiner information for NORMAN, MARC E.

20995 7590 07/31/2013
KNOBBE MARTENS OLSON & BEAR LLP
2040 MAIN STREET
FOURTEENTH FLOOR
IRVINE, CA 92614

DATE MAILED: 07/31/2013

Determination of Patent Term Adjustment under 35 U.S.C. 154 (b)
(application filed on or after May 29, 2000)

The Patent Term Adjustment to date is 666 day(s). If the issue fee is paid on the date that is three months after the mailing date of this notice and the patent issues on the Tuesday before the date that is 28 weeks (six and a half months) after the mailing date of this notice, the Patent Term Adjustment will be 666 day(s).

If a Continued Prosecution Application (CPA) was filed in the above-identified application, the filing date that determines Patent Term Adjustment is the filing date of the most recent CPA.

Applicant will be able to obtain more detailed information by accessing the Patent Application Information Retrieval (PAIR) WEB site (http://pair.uspto.gov).

Any questions regarding the Patent Term Extension or Adjustment determination should be directed to the Office of Patent Legal Administration at (571)-272-7702. Questions relating to issue and publication fee payments should be directed to the Customer Service Center of the Office of Patent Publication at 1-(888)-786-0101 or (571)-272-4200.

Privacy Act Statement

The Privacy Act of 1974 (P.L. 93-579) requires that you be given certain information in connection with your submission of the attached form related to a patent application or patent. Accordingly, pursuant to the requirements of the Act, please be advised that: (1) the general authority for the collection of this information is 35 U.S.C. 2(b)(2); (2) furnishing of the information solicited is voluntary; and (3) the principal purpose for which the information is used by the U.S. Patent and Trademark Office is to process and/or examine your submission related to a patent application or patent. If you do not furnish the requested information, the U.S. Patent and Trademark Office may not be able to process and/or examine your submission, which may result in termination of proceedings or abandonment of the application or expiration of the patent.

The information provided by you in this form will be subject to the following routine uses:

1. The information on this form will be treated confidentially to the extent allowed under the Freedom of Information Act (5 U.S.C. 552) and the Privacy Act (5 U.S.C. 552a). Records from this system of records may be disclosed to the Department of Justice to determine whether disclosure of these records is required by the Freedom of Information Act.
2. A record from this system of records may be disclosed, as a routine use, in the course of presenting evidence to a court, magistrate, or administrative tribunal, including disclosures to opposing counsel in the course of settlement negotiations.
3. A record in this system of records may be disclosed, as a routine use, to a Member of Congress submitting a request involving an individual, to whom the record pertains, when the individual has requested assistance from the Member with respect to the subject matter of the record.
4. A record in this system of records may be disclosed, as a routine use, to a contractor of the Agency having need for the information in order to perform a contract. Recipients of information shall be required to comply with the requirements of the Privacy Act of 1974, as amended, pursuant to 5 U.S.C. 552a(m).
5. A record related to an International Application filed under the Patent Cooperation Treaty in this system of records may be disclosed, as a routine use, to the International Bureau of the World Intellectual Property Organization, pursuant to the Patent Cooperation Treaty.
6. A record in this system of records may be disclosed, as a routine use, to another federal agency for purposes of National Security review (35 U.S.C. 181) and for review pursuant to the Atomic Energy Act (42 U.S.C. 218(c)).
7. A record from this system of records may be disclosed, as a routine use, to the Administrator, General Services, or his/her designee, during an inspection of records conducted by GSA as part of that agency's responsibility to recommend improvements in records management practices and programs, under authority of 44 U.S.C. 2904 and 2906. Such disclosure shall be made in accordance with the GSA regulations governing inspection of records for this purpose, and any other relevant (i.e., GSA or Commerce) directive. Such disclosure shall not be used to make determinations about individuals.
8. A record from this system of records may be disclosed, as a routine use, to the public after either publication of the application pursuant to 35 U.S.C. 122(b) or issuance of a patent pursuant to 35 U.S.C. 151. Further, a record may be disclosed, subject to the limitations of 37 CFR 1.14, as a routine use, to the public if the record was filed in an application which became abandoned or in which the proceedings were terminated and which application is referenced by either a published application, an application open to public inspection or an issued patent.
9. A record from this system of records may be disclosed, as a routine use, to a Federal, State, or local law enforcement agency, if the USPTO becomes aware of a violation or potential violation of law or regulation.

Notice of Allowability	Application No. 12/778,052	Applicant(s) STEINBERG ET AL.	
	Examiner MARC NORMAN	Art Unit 3744	AIA (First Inventor to File) Status No

-- The MAILING DATE of this communication appears on the cover sheet with the correspondence address--

All claims being allowable, PROSECUTION ON THE MERITS IS (OR REMAINS) CLOSED in this application. If not included herewith (or previously mailed), a Notice of Allowance (PTOL-85) or other appropriate communication will be mailed in due course. **THIS NOTICE OF ALLOWABILITY IS NOT A GRANT OF PATENT RIGHTS.** This application is subject to withdrawal from issue at the initiative of the Office or upon petition by the applicant. See 37 CFR 1.313 and MPEP 1308.

1. This communication is responsive to amendment filed 7/12/13.
 A declaration(s)/affidavit(s) under **37 CFR 1.130(b)** was/were filed on _____.
2. An election was made by the applicant in response to a restriction requirement set forth during the interview on _____; the restriction requirement and election have been incorporated into this action.
3. The allowed claim(s) is/are 1-23. As a result of the allowed claim(s), you may be eligible to benefit from the **Patent Prosecution Highway** program at a participating intellectual property office for the corresponding application. For more information, please see http://www.uspto.gov/patents/init_events/oph/index.jsp or send an inquiry to PPHfeedback@uspto.gov.
4. Acknowledgment is made of a claim for foreign priority under 35 U.S.C. § 119(a)-(d) or (f).

Certified copies:

- a) All b) Some *c) None of the:
1. Certified copies of the priority documents have been received.
 2. Certified copies of the priority documents have been received in Application No. _____.
 3. Copies of the certified copies of the priority documents have been received in this national stage application from the International Bureau (PCT Rule 17.2(a)).
- * Certified copies not received: _____.

Applicant has THREE MONTHS FROM THE "MAILING DATE" of this communication to file a reply complying with the requirements noted below. Failure to timely comply will result in ABANDONMENT of this application.
THIS THREE-MONTH PERIOD IS NOT EXTENDABLE.

5. CORRECTED DRAWINGS (as "replacement sheets") must be submitted.
 including changes required by the attached Examiner's Amendment / Comment or in the Office action of Paper No./Mail Date _____.
Identifying indicia such as the application number (see 37 CFR 1.84(c)) should be written on the drawings in the front (not the back) of each sheet. Replacement sheet(s) should be labeled as such in the header according to 37 CFR 1.121(d).
6. DEPOSIT OF and/or INFORMATION about the deposit of BIOLOGICAL MATERIAL must be submitted. Note the attached Examiner's comment regarding REQUIREMENT FOR THE DEPOSIT OF BIOLOGICAL MATERIAL.

Attachment(s)

- | | |
|--|---|
| <ol style="list-style-type: none"> 1. <input type="checkbox"/> Notice of References Cited (PTO-892) 2. <input checked="" type="checkbox"/> Information Disclosure Statements (PTO/SB/08),
Paper No./Mail Date <u>7/12/13</u> 3. <input type="checkbox"/> Examiner's Comment Regarding Requirement for Deposit of Biological Material 4. <input type="checkbox"/> Interview Summary (PTO-413),
Paper No./Mail Date _____. | <ol style="list-style-type: none"> 5. <input checked="" type="checkbox"/> Examiner's Amendment/Comment 6. <input checked="" type="checkbox"/> Examiner's Statement of Reasons for Allowance 7. <input type="checkbox"/> Other _____. |
|--|---|

/Marc E. Norman/
Primary Examiner, Art Unit 3744

EXAMINER'S AMENDMENT

An examiner's amendment to the record appears below. Should the changes and/or additions be unacceptable to applicant, an amendment may be filed as provided by 37 CFR 1.312. To ensure consideration of such an amendment, it MUST be submitted no later than the payment of the issue fee.

The application has been amended as follows:

At claim 1, line 12, "on" has been changed to -- one --.

At claim 17, line 2, "thennostatic" has been changed to -- thermostatic --.

At claim 17, line 22, "to to" has been changed to -- to --.

The following is an examiner's statement of reasons for allowance:

As per independent claim 1, the prior art does not teach the method combination as recited in particular comprising the combined steps of generating with one or more computer processors, a difference value based on comparing an actual setpoint at the first time for said thermostatic controller to the first automated setpoint for said thermostatic controller; detecting a manual change to the first automated setpoint by determining whether said actual setpoint and said first automated setpoint are the same or different based on said difference value; and logging said manual change to a database associated with the thermostatic controller.

As per independent claim 9, the prior art does not teach the method combination as recited in particular comprising comparing the actual setpoint at the first time for said thermostatic controller to the first automated setpoint for said thermostatic controller; detecting a

manual change to the first automated setpoint by determining whether said actual setpoint and said first automated setpoint are the same or different; changing the second automated setpoint at the second time based on at least one rule for the interpretation of said manual change.

As per independent claim 17, the prior art does not teach the apparatus combination as recited an in particular comprising the one or more computer processors configured to calculate scheduled setpoint programming of the programmable communicating thermostat for one or more times based on the predicted rate of change, the scheduled programming comprising one or more automated setpoints; at least a database that stores the one or more automated setpoints associated with the scheduled programming for said programmable communicating thermostat; at least a database that stores actual setpoint programming of said programmable communicating thermostat; and the one or more computer processors configured to compare the one or more automated setpoints associated with said scheduled setpoint programming with said actual setpoint programming.

Any comments considered necessary by applicant must be submitted no later than the payment of the issue fee and, to avoid processing delays, should preferably accompany the issue fee. Such submissions should be clearly labeled "Comments on Statement of Reasons for Allowance."

Any inquiry concerning this communication or earlier communications from the examiner should be directed to MARC NORMAN whose telephone number is (571)272-4812. The examiner can normally be reached on Mon.-Fri., 8:30-5:00.

Application/Control Number: 12/778,052
Art Unit: 3744

Page 4

If attempts to reach the examiner by telephone are unsuccessful, the examiner's supervisor, Cheryl Tyler can be reached on 571-272-4834. The fax phone number for the organization where this application or proceeding is assigned is 571-273-8300.

Information regarding the status of an application may be obtained from the Patent Application Information Retrieval (PAIR) system. Status information for published applications may be obtained from either Private PAIR or Public PAIR. Status information for unpublished applications is available through Private PAIR only. For more information about the PAIR system, see <http://pair-direct.uspto.gov>. Should you have questions on access to the Private PAIR system, contact the Electronic Business Center (EBC) at 866-217-9197 (toll-free). If you would like assistance from a USPTO Customer Service Representative or access to the automated information system, call 800-786-9199 (IN USA OR CANADA) or 571-272-1000.

/Marc E. Norman/
Primary Examiner, Art Unit 3744

Search Notes 	Application/Control No. 12778052	Applicant(s)/Patent Under Reexamination STEINBERG ET AL.
	Examiner MARC NORMAN	Art Unit 3744

CPC- SEARCHED		
Symbol	Date	Examiner

CPC COMBINATION SETS - SEARCHED		
Symbol	Date	Examiner

US CLASSIFICATION SEARCHED			
Class	Subclass	Date	Examiner
236	1C, 46R, 51, 94	4/16/13	MN
62	161, 163	4/16/13	MN
700	276, 278	4/16/13	MN
	updated above	7/16/13	MN

SEARCH NOTES		
Search Notes	Date	Examiner
EAST search (interior/inside/indoor temperature; exterior/outside/outdoor temperature; rate of change; setpoint; time; manual; automatic; etc.); inventor name search	4/16/13	MN

INTERFERENCE SEARCH			
US Class/ CPC Symbol	US Subclass / CPC Group	Date	Examiner
236	1C, 46R, 51, 94	7/16/13	MN
62	161, 163	7/16/13	MN
700	276, 278	7/16/13	MN

--	--

date received: 7/12/13 /MN/

PTO/SB/08 Equivalent

INFORMATION DISCLOSURE STATEMENT BY APPLICANT	Application No.	12/778,052
	Filing Date	May 11, 2010
	First Named Inventor	John Douglas Steinberg
	Art Unit	3744
<i>(Multiple sheets used when necessary)</i>		Examiner Norman, Marc E.
SHEET 1 OF 2		Attorney Docket No. EFACT.007A

U.S. PATENT DOCUMENTS					
Examiner Initials	Cite No.	Document Number <i>Number - Kind Code (if known)</i> Example: 1,234,567 B1	Publication Date MM-DD-YYYY	Name of Patentee or Applicant	Pages, Columns, Lines Where Relevant Passages or Relevant Figures Appear
	1	6,400,956	06-02-2002	Richton	
	2	8,457,797	06-04-2013	Imes, et al.	
	3	2010/0289643	11-18-2010	Trundle, et al.	
	4	2011/0046792	02-24-2011	Imes, et al.	
	5	2011/0046798	02-24-2011	Imes, et al.	
	6	2011/0046799	02-24-2011	Imes, et al.	
	7	2011/0046800	02-24-2011	Imes, et al.	
	8	2011/0046801	02-24-2011	Imes, et al.	
	9	2011/0051823	03-03-2011	Imes, et al.	
	10	2011/0054699	03-03-2011	Imes, et al.	
	11	2011/0054710	03-03-2011	Imes, et al.	
	12	2011/0173542	07-14-2011	Imes, et al.	
	13	2011/0202185	08-18-2011	Imes, et al.	
	14	2011/0214060	09-01-2011	Imes, et al.	
	15	2011/0224838	09-15-2011	Imes, et al.	
	16	2011/0246898	10-06-2011	Imes, et al.	
	17	2011/0307101	12-15-2011	Imes, et al.	
	18	2012/0023225	01-26-2012	Imes, et al.	
	19	2012/0046859	02-23-2012	Imes, et al.	
	20	2012/0064923	03-15-2012	Imes, et al.	
	21	2012/0072033	03-22-2012	Imes, et al.	
	22	2012/0093141	04-19-2012	Imes, et al.	
	23	2012/0101637	04-26-2012	Imes, et al.	
	24	2012/0135759	05-31-2012	Imes, et al.	
	25	2012/0215725	08-23-2012	Imes, et al.	
	26	2012/0221718	08-30-2012	Imes, et al.	
	27	2012/0252430	10-04-2012	Imes, et al.	
	28	2012/0324119	12-20-2012	Imes, et al.	
	29	2013/0053054	02-28-2013	Lovitt, et al.	

Examiner Signature	Date Considered
*Examiner: Initial if reference considered, whether or not citation is in conformance with MPEP 609. Draw line through citation if not in conformance and not considered. Include copy of this form with next communication to applicant.	

T¹ - Place a check mark in this area when an English language Translation is attached.

ALL REFERENCES CONSIDERED EXCEPT WHERE LINED THROUGH. /MN/

INFORMATION DISCLOSURE STATEMENT BY APPLICANT	Application No.	12/778,052	
	Filing Date	May 11, 2010	
	First Named Inventor	John Douglas Steinberg	
	Art Unit	3744	
<i>(Multiple sheets used when necessary)</i>		Examiner	Norman, Marc E.
SHEET 2 OF 2		Attorney Docket No.	EFACT.007A

U.S. PATENT DOCUMENTS					
Examiner Initials	Cite No.	Document Number <i>Number - Kind Code (if known)</i> Example: 1,234,567 B1	Publication Date MM-DD-YYYY	Name of Patentee or Applicant	Pages, Columns, Lines Where Relevant Passages or Relevant Figures Appear
	30	2013/0054758	02-28-2013	Imes, et al.	
	31	2013/0054863	02-28-2013	Imes, et al.	
	32	2013/0060387	03-07-2013	Imes, et al.	
	33	2013/0144453	06-06-2013	Subbloie	
	34	2013/0167035	06-27-2013	Imes, et al.	

FOREIGN PATENT DOCUMENTS						
Examiner Initials	Cite No.	Foreign Patent Document <i>Country Code-Number-Kind Code</i> Example: JP 1234567 A1	Publication Date MM-DD-YYYY	Name of Patentee or Applicant	Pages, Columns, Lines Where Relevant Passages or Relevant Figures Appear	T ¹

NON PATENT LITERATURE DOCUMENTS			
Examiner Initials	Cite No.	Include name of the author (in CAPITAL LETTERS), title of the article (when appropriate), title of the item (book, magazine, journal, serial, symposium, catalog, etc.), date, page(s), volume-issue number(s), publisher, city and/or country where published.	T ¹
	35	Brush, et al., Preheat – Controlling Home Heating with Occupancy Prediction, 2013	
	36	Gupta, et al., A Persuasive GPS-Controlled Thermostat System, MIT, 2008	
	37	Gupta, Adding GPS-Control to Traditional Thermostats: An Exploration of Potential Energy Savings and Design Challenges, MIT, 2009	
	38	Krumm, et al., Learning Time-Based Presence Probabilities, June 2011	
	39	Scott, et al., Home Heating Using GPS-Based Arrival Prediction, 2010	

15784819:ad
071113

Examiner Signature	/Marc Norman/	Date Considered	07/16/2013
*Examiner: Initial if reference considered, whether or not citation is in conformance with MPEP 609. Draw line through citation if not in conformance and not considered. Include copy of this form with next communication to applicant.			

T¹ - Place a check mark in this area when an English language Translation is attached.

ALL REFERENCES CONSIDERED EXCEPT WHERE LINED THROUGH. /MN/

<i>Index of Claims</i> 	Application/Control No. 12778052	Applicant(s)/Patent Under Reexamination STEINBERG ET AL.
	Examiner MARC NORMAN	Art Unit 3744

✓	Rejected
=	Allowed

-	Cancelled
÷	Restricted

N	Non-Elected
I	Interference

A	Appeal
O	Objected

Claims renumbered in the same order as presented by applicant
 CPA
 T.D.
 R.1.47

CLAIM		DATE							
Final	Original	04/16/2013	07/16/2013						
	1	✓	=						
	2	✓	=						
	3	✓	=						
	4	✓	=						
	5	✓	=						
	6	✓	=						
	7	✓	=						
	8	✓	=						
	9	=	=						
	10	=	=						
	11	=	=						
	12	=	=						
	13	=	=						
	14	=	=						
	15	=	=						
	16	=	=						
	17	=	=						
	18	=	=						
	19	=	=						
	20	=	=						
	21	=	=						
	22	=	=						
	23	=	=						

IN THE UNITED STATES PATENT AND TRADEMARK OFFICE

Inventor	: John Douglas Steinberg, et al.
App. No.	: 12/778,052
Filed	: May 11, 2010
For	: SYSTEM, METHOD AND APPARATUS FOR IDENTIFYING MANUAL INPUTS TO AND ADAPTIVE PROGRAMMING OF A THERMOSTAT
Examiner	: Norman, Marc E.
Art Unit	: 3744
Conf No.	: 5650

RESPONSE TO OFFICE ACTION DATED MAY 7, 2013**Mail Stop Amendment**

Commissioner for Patents
P.O. Box 1450
Alexandria, VA 22313-1450

Dear Sir:

In response to the Office Action mailed May 7, 2013, Applicant respectfully submits the following amendments and comments.

Amendments to the Claims are reflected in the listing of claims which begins on page 2 of this paper.

Summary of Interview begins on page 6 of this paper.

Remarks/Arguments begin on page 7 of this paper.

Application No.: 12/778,052
Filing Date: May 11, 2010

AMENDMENTS TO THE CLAIMS

Please amend Claim 1 as indicated below.

1. (Currently Amended) A method for detecting manual changes to the setpoint for a thermostatic controller comprising:

accessing stored data comprising a plurality of internal temperature measurements taken within a structure and a plurality of outside temperature measurements relating to temperatures outside the structure;

using the stored data to predict a rate of change of temperatures inside the structure in response to at least changes in outside temperatures;

calculating with one or more computer processors, scheduled programming of the thermostatic controller for one or more times based on the predicted rate of change, the scheduled programming comprising at least a first automated setpoint at a first time;

generating with one or more computer processors, a difference value based on comparing an actual setpoint at the first time for said thermostatic controller to the first automated setpoint for said thermostatic controller; and

detecting a manual change to the first automated setpoint by determining whether said actual setpoint and said first automated setpoint are the same or different based on said difference value; and

logging said manual change to a database associated with the thermostatic controller.

2. (Original) A method as in Claim 1 where said thermostatic controller operates a system for changing the air temperature in a structure.

3. (Original) A method as in Claim 1 where said thermostatic controller operates a heating, ventilation and air conditioning system.

4. (Original) A method as in Claim 1 where said thermostatic controller operates a heating, ventilation and air conditioning system in a single family residence.

Application No.: 12/778,052
Filing Date: May 11, 2010

5. (Original) A method as in Claim 1 in which at least one remote processor is in communication with said thermostatic control device.

6. (Original) A method as in Claim 5 in which said remote processor is not located in the same structure as said thermostatic controller.

7. (Original) A method as in Claim 5 in which said remote processor sets programming for said thermostatic controller.

8. (Original) A method as in Claim 1 in which said thermostatic controller is programmable.

9. (Previously Presented) A method for incorporating manual changes to the setpoint for a thermostatic controller into long-term programming of said thermostatic controller comprising:

accessing stored data comprising a plurality of internal temperature measurements taken within a structure and a plurality of outside temperature measurements relating to temperatures outside the structure;

using the stored data to predict a rate of change of temperatures inside the structure in response to at least changes in outside temperatures;

calculating scheduled programming of setpoints in the thermostatic controller based on the predicted rate of change, the scheduled programming comprising at least a first automated setpoint at a first time and a second automated setpoint at a second time;

comparing the actual setpoint at the first time for said thermostatic controller to the first automated setpoint for said thermostatic controller ;

detecting a manual change to the first automated setpoint by determining whether said actual setpoint and said first automated setpoint are the same or different;

changing the second automated setpoint at the second time based on at least one rule for the interpretation of said manual change.

Application No.: 12/778,052
Filing Date: May 11, 2010

10. (Original) A method as in Claim 9 where said thermostatic controller operates a system for changing the air temperature in a structure.

11. (Original) A method as in Claim 9 where said thermostatic controller operates a heating, ventilation and air conditioning system.

12. (Original) A method as in Claim 9 where said thermostatic controller operates a heating, ventilation and air conditioning system in a single family residence.

13. (Original) A method as in Claim 9 in which at least one remote processor is in communication with said thermostatic control device.

14. (Original) A method as in Claim 13 in which said remote processor is not located in the same structure as said thermostatic controller.

15. (Original) A method as in Claim 13 in which said remote processor sets programming for said thermostatic controller.

16. (Original) A system as in Claim 9 in which said thermostatic controller is programmable.

17. (Previously Presented) An apparatus for detecting manual changes to the setpoint for a thermostatic controller comprising:

at least a programmable communicating thermostat;

at least a remote processor;

at least a network connecting said remote processor and said communicating;

at least a database comprising a plurality of internal temperature measurements taken within a structure and a plurality of outside temperature measurements relating to temperatures outside the structure;

computer hardware comprising one or more computer processors configured to use the stored data to predict a rate of change of temperatures inside the structure in response to changes in outside temperatures;

Application No.: 12/778,052
Filing Date: May 11, 2010

the one or more computer processors configured to calculate scheduled setpoint programming of the programmable communicating thermostat for one or more times based on the predicted rate of change, the scheduled programming comprising one or more automated setpoints;

at least a database that stores the one or more automated setpoints associated with the scheduled programming for said programmable communicating thermostat;

at least a database that stores actual setpoint programming of said programmable communicating thermostat; and

the one or more computer processors configured to compare the one or more automated setpoints associated with said scheduled setpoint programming with said actual setpoint programming.

18. (Original) An apparatus as in claim 17 where said programmable communicating thermostat operates a system for changing the air temperature in a structure.

19. (Original) An apparatus as in claim 17 where said programmable communicating thermostat operates a heating, ventilation and air conditioning system.

20. (Original) An apparatus as in claim 17 where said programmable communicating thermostat operates a heating, ventilation and air conditioning system in a single family residence.

21. (Original) An apparatus as in claim 20 in which at least one remote processor is in communication with said programmable communicating thermostat.

22. (Original) An apparatus as in claim 20 in which said remote processor is not located in the same structure as said programmable communicating thermostat.

23. (Original) An apparatus as in claim 20 in which said remote processor sets programming for said programmable communicating thermostat.

Application No.: 12/778,052
Filing Date: May 11, 2010

SUMMARY OF INTERVIEW

Attendees, Date and Type of Interview

The interview was conducted on June 11, 2013 and attended by Examiner Marc E. Norman, John D. Steinberg, and John R. King.

Exhibits and/or Demonstrations

None.

Identification of Claims Discussed

Claim 1.

Identification of Prior Art Discussed

None.

Proposed Amendments

Please see the amendments to claim 1 as set forth above.

Principal Arguments and Other Matters

Please see the remarks set forth below.

Results of Interview

It was Applicant's understanding that the proposed amendments addressed the Section 101 issues. It was also Applicant's understanding that Examiner Norman would further review the amendments upon submission of this response.

Application No.: 12/778,052
Filing Date: May 11, 2010

REMARKS

The May 7, 2013 Office Action was based upon pending Claims 1-23. Claims 9-23 are allowed. This Amendment amends Claim 1. Thus, after entry of this Amendment, Claims 1-23 are pending and presented for further consideration.

INTERVIEW

Applicant would like to thank Examiner Norman for the interview extended to John Steinberg and Applicant's counsel of record, John R. King, on June 11, 2013. The interview helped clarify the Examiner's concerns regarding Claim 1.

REJECTION OF CLAIMS 1-8 UNDER 35 U.S.C. §101

Claims 1-8 were rejected under 35 U.S.C. §101 because the claimed invention is directed to non-statutory subject matter.

As discussed in the interview, Applicant has amended the claims such that they are directed to a statutory machine. Furthermore, Applicant has amended the claims to clarify the transformative nature of generating a difference value and to include post processing activity of logging the manual change to a database.

Thus, Applicant respectfully requests allowance of Claim 1 and dependent Claims 2-8.

ALLOWABLE SUBJECT MATTER

Claims 9-23 were allowed.

OTHER APPLICATIONS OF ASSIGNEE

Applicant wishes to draw the Examiner's attention to the following applications owned by of the present application's assignee:

Inventors	Appl. No.	Filing Date	Attorney Docket No.	Title
Steinberg et al.	60/963,183 Now Expired	08/03/07	EFACT.003PR	System And Method For Using A Network Of Thermostats As Tool To Verify Peak Demand Reduction

Application No.: 12/778,052
Filing Date: May 11, 2010

Inventors	Appl. No.	Filing Date	Attorney Docket No.	Title
Steinberg et al.	60/944,011 Now Expired	09/17/07	EFACT.005PR	System And Method For Calculating The Thermal Mass Of A Building
Steinberg et al.	12/183,990 Now Pat. 7,908,117	07/31/08	EFACT.003A	System And Method For Using A Network Of Thermostats As Tool To Verify Peak Demand Reduction
Steinberg et al.	12/183,949 Now Pat. 7,908,116	07/31/08	EFACT.004A	System And Method For Using A Network Of Thermostats As Tool To Verify Peak Demand Reduction
Steinberg et al.	12/211,733 Now Pat. 7,848,900	09/16/08	EFACT.005A	System And Method For Calculating The Thermal Mass Of A Building
Steinberg et al.	12/211,690 Now Pat. 8,019,567	09/16/08	EFACT.006A	System And Method For Evaluating Changes In The Efficiency Of An HVAC System
Steinberg	61/215,816 Now Expired	05/11/09	EFACT.008PR	System, Method And Apparatus For Dynamically Variable Compressor Delay In Thermostat To Reduce Energy Consumption
Steinberg et al.	61/215,657 Now Expired	05/08/09	EFACT.009PR	System, Method And Apparatus For Just-In-Time Conditioning Using A Thermostat
Steinberg et al.	61/215,999 Now Expired	05/12/09	EFACT.007PR	System, Method And Apparatus For Identifying Manual Inputs To And Adaptive Programming Of A Thermostat
Cheung et al.	12/498,142 Now Pat. 8,010,237	07/06/09	EFACT.010A	System And Method For Using Ramped Setpoint Temperature Variation With Networked Thermostats To Improve Efficiency
Steinberg	12/502,064 Now Pat. 8,180,492	07/13/09	EFACT.011A	System And Method For Using A Networked Electronic Device As An Occupancy Sensor For An Energy Management System
Steinberg et al.	12/773,690 Published 2010/0318227	05/04/10	EFACT.009A	System, Method And Apparatus For Just-In-Time Conditioning Using A Thermostat
Steinberg	12/774,580 Published 2010/0282857	05/05/10	EFACT.008A	System, Method And Apparatus For Dynamically Variable Compressor Delay In Thermostat To Reduce Energy Consumption
Steinberg	12/788,246 Published 2011/0290893	05/26/10	EFACT.012A	System And Method For Using A Mobile Electronic Device To Optimize An Energy Management System

Application No.: 12/778,052
Filing Date: May 11, 2010

Inventors	Appl. No.	Filing Date	Attorney Docket No.	Title
Steinberg	12/860,821 Now Pat. 8,090,477	08/20/10	EFACT.013A	System And Method For Optimizing Use Of Plug-In Air Conditioners And Portable Heaters
Steinberg et al.	12/959,225 Now Pat. 8,131,497	12/02/10	EFACT.005C1	System And Method For Calculating The Thermal Mass Of A Building
Steinberg et al.	13/037,162 Now Pat. 8,131,506	02/28/11	EFACT.004C1	System And Method For Using A Network Of Thermostats As Tool To Verify Peak Demand Reduction
Cheung et al.	13/219,381 Published 2011/0307103	08/26/11	EFACT.010C1	System And Method For Using Ramped Setpoint Temperature Variation With Networked Thermostats To Improve Efficiency
Steinberg et al.	13/230,610 Published 2012/0065935	09/12/11	EFACT.006C1	System And Method For Evaluating Changes In The Efficiency Of An HVAC System
Steinberg	13/329,117 Now Pat. 8,340,826	12/16/11	EFACT.013C1	System And Method For Optimizing Use Of Plug-In Air Conditioners And Portable Heaters
Steinberg	13/470,074 Published 2012/0221151	05/11/12	EFACT.011C1	System And Method For Using A Wireless Device As A Sensor For An Energy Management System
Steinberg et al.	13/409,729 Published 2012/0158350	03/01/12	EFACT.005C2	System And Method For Calculating The Thermal Mass Of A Building
Steinberg et al.	13/409,697 Published 2012/0221294	03/01/12	EFACT.004C2	System And Method For Using A Network Of Thermostats As Tool To Verify Peak Demand Reduction
Hublou et al.	13/523,697	06/14/12	EFACT.014A	System And Method For Optimizing Use Of Individual Hvac Units In Multi-Unit Chiller-Based Systems
Steinberg	13/725,447 Published 2013/0144445	12/21/12	EFACT.013C2	System And Method For Optimizing Use Of Plug-In Air Conditioners And Portable Heaters

Applicant notes that cited references, office actions, responses and notices of allowance currently exist or will exist for the above-referenced matters. Applicant also understands that the Examiner has access to sophisticated online Patent Office computing systems that provide ready access to the full file histories of these matters

Application No.: 12/778,052
Filing Date: May 11, 2010

including, for example, specifications, drawings, pending claims, cited art, office actions, responses, declarations, and notices of allowance.

Rather than submit copies these file histories, Applicant respectfully requests that the Examiner continue to review these file histories online for past, current, and future information about these matters. Also, if the Examiner cannot readily access these file histories, the Applicant would be pleased to provide any portion of any of the file histories at any time upon specific Examiner request.

SUPPLEMENTAL INFORMATION DISCLOSURE STATEMENT

Submitted concurrently herewith is a Supplemental Information Disclosure Statement citing references for consideration. Applicant respectfully requests the Examiner to consider the pending claims in connection with these references in order to make the references of record.

NO DISCLAIMERS OR DISAVOWALS

Although the present communication may include alterations to the application or claims, or characterizations of claim scope or referenced art, Applicant is not conceding in this application that previously pending claims are not patentable over the cited references. Rather, any alterations or characterizations are being made to facilitate expeditious prosecution of this application.

Applicant reserves the right to pursue at a later date any previously pending or other broader or narrower claims that capture any subject matter supported by the present disclosure, including subject matter found to be specifically disclaimed herein or by any prior prosecution.

Accordingly, reviewers of this or any parent, child or related prosecution history shall not reasonably infer that Applicant has made any disclaimers or disavowals of any subject matter supported by the present application.

Application No.: 12/778,052
Filing Date: May 11, 2010

CONCLUSION

Applicants have endeavored to address all of the Examiner's concerns as expressed in the outstanding Office Action. In light of the above remarks, reconsideration and withdrawal of the outstanding rejections is specifically requested.

Please charge any additional fees, including any fees for additional extension of time, or credit overpayment to Deposit Account No. 11-1410.

Respectfully submitted,

KNOBBE, MARTENS, OLSON & BEAR, LLP

Dated: 7-12-2013

By: John R. King
John R. King
Registration No. 34,362
Attorney of Record
Customer No. 20995
(949) 760-0404

15616856
071213

INFORMATION DISCLOSURE STATEMENT

Inventor : John Douglas Steinberg, et al.
App. No. : 12/778,052
Filed : May 11, 2010
For : SYSTEM, METHOD AND APPARATUS FOR
IDENTIFYING MANUAL INPUTS TO AND ADAPTIVE
PROGRAMMING OF A THERMOSTAT
Examiner : Norman, Marc E.
Art Unit : 3744
Conf. No. : 5650

Mail Stop Amendment
Commissioner for Patents
P.O. Box 1450
Alexandria, VA 22313-1450

References and Listing

Submitted herewith in the above-identified application is an Information Disclosure Statement listing references for consideration. Copies of any listed foreign and non-patent literature references are being submitted.

Timing of Disclosure

This Information Disclosure Statement is being filed after receipt of a First Office Action, but before the mailing date of a Final Action and before the mailing date of a Notice of Allowance. This Statement is accompanied by the fees set forth in 37 C.F.R. 1.17(p). The Commissioner is hereby authorized to charge any additional fees which may be required or to credit any overpayment to Account No. 11-1410.

Respectfully submitted,
KNOBBE, MARTENS, OLSON & BEAR, LLP

Dated: 7-12-2013

By: John R. King
John R. King
Registration No. 34,362
Attorney of Record
Customer No. 20995
(949) 760-0404

INFORMATION DISCLOSURE STATEMENT BY APPLICANT	Application No.	12/778,052
	Filing Date	May 11, 2010
	First Named Inventor	John Douglas Steinberg
	Art Unit	3744
<i>(Multiple sheets used when necessary)</i>		Examiner Norman, Marc E.
SHEET 1 OF 2		Attorney Docket No. EFACT.007A

U.S. PATENT DOCUMENTS					
Examiner Initials	Cite No.	Document Number <i>Number - Kind Code (if known)</i> Example: 1,234,567 B1	Publication Date MM-DD-YYYY	Name of Patentee or Applicant	Pages, Columns, Lines Where Relevant Passages or Relevant Figures Appear
	1	6,400,956	06-02-2002	Richton	
	2	8,457,797	06-04-2013	Imes, et al.	
	3	2010/0289643	11-18-2010	Trundle, et al.	
	4	2011/0046792	02-24-2011	Imes, et al.	
	5	2011/0046798	02-24-2011	Imes, et al.	
	6	2011/0046799	02-24-2011	Imes, et al.	
	7	2011/0046800	02-24-2011	Imes, et al.	
	8	2011/0046801	02-24-2011	Imes, et al.	
	9	2011/0051823	03-03-2011	Imes, et al.	
	10	2011/0054699	03-03-2011	Imes, et al.	
	11	2011/0054710	03-03-2011	Imes, et al.	
	12	2011/0173542	07-14-2011	Imes, et al.	
	13	2011/0202185	08-18-2011	Imes, et al.	
	14	2011/0214060	09-01-2011	Imes, et al.	
	15	2011/0224838	09-15-2011	Imes, et al.	
	16	2011/0246898	10-06-2011	Imes, et al.	
	17	2011/0307101	12-15-2011	Imes, et al.	
	18	2012/0023225	01-26-2012	Imes, et al.	
	19	2012/0046859	02-23-2012	Imes, et al.	
	20	2012/0064923	03-15-2012	Imes, et al.	
	21	2012/0072033	03-22-2012	Imes, et al.	
	22	2012/0093141	04-19-2012	Imes, et al.	
	23	2012/0101637	04-26-2012	Imes, et al.	
	24	2012/0135759	05-31-2012	Imes, et al.	
	25	2012/0215725	08-23-2012	Imes, et al.	
	26	2012/0221718	08-30-2012	Imes, et al.	
	27	2012/0252430	10-04-2012	Imes, et al.	
	28	2012/0324119	12-20-2012	Imes, et al.	
	29	2013/0053054	02-28-2013	Lovitt, et al.	

Examiner Signature	Date Considered
<p>*Examiner: Initial if reference considered, whether or not citation is in conformance with MPEP 609. Draw line through citation if not in conformance and not considered. Include copy of this form with next communication to applicant.</p>	

T¹ - Place a check mark in this area when an English language Translation is attached.

INFORMATION DISCLOSURE STATEMENT BY APPLICANT	Application No.	12/778,052	
	Filing Date	May 11, 2010	
	First Named Inventor	John Douglas Steinberg	
	Art Unit	3744	
<i>(Multiple sheets used when necessary)</i>		Examiner	Norman, Marc E.
SHEET 2 OF 2		Attorney Docket No.	EFACT.007A

U.S. PATENT DOCUMENTS					
Examiner Initials	Cite No.	Document Number <i>Number - Kind Code (if known)</i> Example: 1,234,567 B1	Publication Date MM-DD-YYYY	Name of Patentee or Applicant	Pages, Columns, Lines Where Relevant Passages or Relevant Figures Appear
	30	2013/0054758	02-28-2013	Imes, et al.	
	31	2013/0054863	02-28-2013	Imes, et al.	
	32	2013/0060387	03-07-2013	Imes, et al.	
	33	2013/0144453	06-06-2013	Subbloie	
	34	2013/0167035	06-27-2013	Imes, et al.	

FOREIGN PATENT DOCUMENTS						
Examiner Initials	Cite No.	Foreign Patent Document <i>Country Code-Number-Kind Code</i> Example: JP 1234567 A1	Publication Date MM-DD-YYYY	Name of Patentee or Applicant	Pages, Columns, Lines Where Relevant Passages or Relevant Figures Appear	T ¹

NON PATENT LITERATURE DOCUMENTS					
Examiner Initials	Cite No.	Include name of the author (in CAPITAL LETTERS), title of the article (when appropriate), title of the item (book, magazine, journal, serial, symposium, catalog, etc.), date, page(s), volume-issue number(s), publisher, city and/or country where published.			T ¹
	35	Brush, et al., Preheat – Controlling Home Heating with Occupancy Prediction, 2013			
	36	Gupta, et al., A Persuasive GPS-Controlled Thermostat System, MIT, 2008			
	37	Gupta, Adding GPS-Control to Traditional Thermostats: An Exploration of Potential Energy Savings and Design Challenges, MIT, 2009			
	38	Krumm, et al., Learning Time-Based Presence Probabilities, June 2011			
	39	Scott, et al., Home Heating Using GPS-Based Arrival Prediction, 2010			

15784819:ad
071113

Examiner Signature	Date Considered
*Examiner: Initial if reference considered, whether or not citation is in conformance with MPEP 609. Draw line through citation if not in conformance and not considered. Include copy of this form with next communication to applicant.	

T¹ - Place a check mark in this area when an English language Translation is attached.

Electronic Patent Application Fee Transmittal

Application Number:	12778052			
Filing Date:	11-May-2010			
Title of Invention:	SYSTEM, METHOD AND APPARATUS FOR IDENTIFYING MANUAL INPUTS TO AND ADAPTIVE PROGRAMMING OF A THERMOSTAT			
First Named Inventor/Applicant Name:	John Douglas Steinberg			
Filer:	John R. King/Amy Durrant			
Attorney Docket Number:	EFACT.007A			
Filed as Small Entity				
Utility under 35 USC 111 (a) Filing Fees				
Description	Fee Code	Quantity	Amount	Sub-Total in USD(\$)
Basic Filing:				
Pages:				
Claims:				
Miscellaneous-Filing:				
Petition:				
Patent-Appeals-and-Interference:				
Post-Allowance-and-Post-Issuance:				
Extension-of-Time:				

Description	Fee Code	Quantity	Amount	Sub-Total in USD(\$)
Miscellaneous:				
Submission- Information Disclosure Stmt	2806	1	90	90
Total in USD (\$)				90

Electronic Acknowledgement Receipt

EFS ID:	16306427
Application Number:	12778052
International Application Number:	
Confirmation Number:	5650
Title of Invention:	SYSTEM, METHOD AND APPARATUS FOR IDENTIFYING MANUAL INPUTS TO AND ADAPTIVE PROGRAMMING OF A THERMOSTAT
First Named Inventor/Applicant Name:	John Douglas Steinberg
Customer Number:	20995
Filer:	John R. King/Gustavo Lopez
Filer Authorized By:	John R. King
Attorney Docket Number:	EFACT.007A
Receipt Date:	12-JUL-2013
Filing Date:	11-MAY-2010
Time Stamp:	18:20:46
Application Type:	Utility under 35 USC 111(a)

Payment information:

Submitted with Payment	yes
Payment Type	Credit Card
Payment was successfully received in RAM	\$90
RAM confirmation Number	5438
Deposit Account	111410
Authorized User	KNOBBE MARTENS OLSON AND BEAR

The Director of the USPTO is hereby authorized to charge indicated fees and credit any overpayment as follows:

Charge any Additional Fees required under 37 C.F.R. Section 1.16 (National application filing, search, and examination fees)

Charge any Additional Fees required under 37 C.F.R. Section 1.17 (Patent application and reexamination processing fees)

File Listing:					
Document Number	Document Description	File Name	File Size(Bytes)/ Message Digest	Multi Part /.zip	Pages (if appl.)
1		EFACT-007A_response.pdf	461662 2f38bbe8c10b95ac720668805d2c443adbd29cc7	yes	11
Multipart Description/PDF files in .zip description					
		Document Description	Start	End	
		Amendment/Req. Reconsideration-After Non-Final Reject	1	1	
		Claims	2	5	
		Applicant summary of interview with examiner	6	6	
		Applicant Arguments/Remarks Made in an Amendment	7	11	
Warnings:					
Information:					
2		EFACT-007A_ids.pdf	160673 2efbcdbc385a5283f177fc1bf303b24dd1d77dc5	yes	3
Multipart Description/PDF files in .zip description					
		Document Description	Start	End	
		Transmittal Letter	1	1	
		Information Disclosure Statement (IDS) Form (SB08)	2	3	
Warnings:					
Information:					
3	Non Patent Literature	EFACT-007A_REF35.pdf	145595 206795b362b2c6dcd727002c5c6e37e4e830adc7	no	2
Warnings:					
Information:					
4	Non Patent Literature	EFACT-007A_REF36.pdf	19460336 e91911e3630eb74c51840c1633846cc8df9b03fe	no	89
Warnings:					
Information:					
5	Non Patent Literature	EFACT-007A_REF37.pdf	1031319 a4b4be49306214277afc1e3e306cb52a012c9d7	no	18
Warnings:					

Information:					
6	Non Patent Literature	EFACT-007A_REF39.pdf	144968	no	6
			17f2628ebae5d13f5124c19818a4709177f93359		
Warnings:					
Information:					
7	Non Patent Literature	EFACT-007A_REF38.pdf	1253996	no	18
			a59d8baa578f2786d8b276c8b37a512396f71834		
Warnings:					
Information:					
8	Fee Worksheet (SB06)	fee-info.pdf	30380	no	2
			7cea7454517cb3310ca7657f17194173d2426aa1		
Warnings:					
Information:					
Total Files Size (in bytes):			22688929		
<p>This Acknowledgement Receipt evidences receipt on the noted date by the USPTO of the indicated documents, characterized by the applicant, and including page counts, where applicable. It serves as evidence of receipt similar to a Post Card, as described in MPEP 503.</p> <p><u>New Applications Under 35 U.S.C. 111</u> If a new application is being filed and the application includes the necessary components for a filing date (see 37 CFR 1.53(b)-(d) and MPEP 506), a Filing Receipt (37 CFR 1.54) will be issued in due course and the date shown on this Acknowledgement Receipt will establish the filing date of the application.</p> <p><u>National Stage of an International Application under 35 U.S.C. 371</u> If a timely submission to enter the national stage of an international application is compliant with the conditions of 35 U.S.C. 371 and other applicable requirements a Form PCT/DO/EO/903 indicating acceptance of the application as a national stage submission under 35 U.S.C. 371 will be issued in addition to the Filing Receipt, in due course.</p> <p><u>New International Application Filed with the USPTO as a Receiving Office</u> If a new international application is being filed and the international application includes the necessary components for an international filing date (see PCT Article 11 and MPEP 1810), a Notification of the International Application Number and of the International Filing Date (Form PCT/RO/105) will be issued in due course, subject to prescriptions concerning national security, and the date shown on this Acknowledgement Receipt will establish the international filing date of the application.</p>					

Under the Paperwork Reduction Act of 1995, no persons are required to respond to a collection of information unless it displays a valid OMB control number.

PATENT APPLICATION FEE DETERMINATION RECORD Substitute for Form PTO-875	Application or Docket Number 12/778,052	Filing Date 05/11/2010	<input type="checkbox"/> To be Mailed
---	---	----------------------------------	---------------------------------------

ENTITY: LARGE SMALL MICRO

APPLICATION AS FILED – PART I

FOR	NUMBER FILED	NUMBER EXTRA	RATE (\$)	FEE (\$)
<input type="checkbox"/> BASIC FEE (37 CFR 1.16(a), (b), or (c))	N/A	N/A	N/A	
<input type="checkbox"/> SEARCH FEE (37 CFR 1.16(k), (l), or (m))	N/A	N/A	N/A	
<input type="checkbox"/> EXAMINATION FEE (37 CFR 1.16(o), (p), or (q))	N/A	N/A	N/A	
TOTAL CLAIMS (37 CFR 1.16(i))	minus 20 = *		X \$ =	
INDEPENDENT CLAIMS (37 CFR 1.16(h))	minus 3 = *		X \$ =	
<input type="checkbox"/> APPLICATION SIZE FEE (37 CFR 1.16(s))	If the specification and drawings exceed 100 sheets of paper, the application size fee due is \$310 (\$155 for small entity) for each additional 50 sheets or fraction thereof. See 35 U.S.C. 41(a)(1)(G) and 37 CFR 1.16(s).			
<input type="checkbox"/> MULTIPLE DEPENDENT CLAIM PRESENT (37 CFR 1.16(j))				
* If the difference in column 1 is less than zero, enter "0" in column 2.				TOTAL

APPLICATION AS AMENDED – PART II

	(Column 1)	(Column 2)	(Column 3)	PRESENT EXTRA	RATE (\$)	ADDITIONAL FEE (\$)	
AMENDMENT	07/12/2013	CLAIMS REMAINING AFTER AMENDMENT		HIGHEST NUMBER PREVIOUSLY PAID FOR			
		* 23	Minus	** 23	= 0	X \$40 = 0	
		Independent (37 CFR 1.16(h)) * 3	Minus	***3	= 0	X \$210 = 0	
		<input type="checkbox"/> Application Size Fee (37 CFR 1.16(s))					
		<input type="checkbox"/> FIRST PRESENTATION OF MULTIPLE DEPENDENT CLAIM (37 CFR 1.16(j))					
TOTAL ADD'L FEE						0	

	(Column 1)	(Column 2)	(Column 3)	PRESENT EXTRA	RATE (\$)	ADDITIONAL FEE (\$)	
AMENDMENT		CLAIMS REMAINING AFTER AMENDMENT		HIGHEST NUMBER PREVIOUSLY PAID FOR			
		*	Minus	**	=	X \$ =	
		Independent (37 CFR 1.16(h)) *	Minus	***	=	X \$ =	
		<input type="checkbox"/> Application Size Fee (37 CFR 1.16(s))					
		<input type="checkbox"/> FIRST PRESENTATION OF MULTIPLE DEPENDENT CLAIM (37 CFR 1.16(j))					
TOTAL ADD'L FEE							

* If the entry in column 1 is less than the entry in column 2, write "0" in column 3.
 ** If the "Highest Number Previously Paid For" IN THIS SPACE is less than 20, enter "20".
 *** If the "Highest Number Previously Paid For" IN THIS SPACE is less than 3, enter "3".
 The "Highest Number Previously Paid For" (Total or Independent) is the highest number found in the appropriate box in column 1.

LIE
/ANDREA FREEMAN/

This collection of information is required by 37 CFR 1.16. The information is required to obtain or retain a benefit by the public which is to file (and by the USPTO to process) an application. Confidentiality is governed by 35 U.S.C. 122 and 37 CFR 1.14. This collection is estimated to take 12 minutes to complete, including gathering, preparing, and submitting the completed application form to the USPTO. Time will vary depending upon the individual case. Any comments on the amount of time you require to complete this form and/or suggestions for reducing this burden, should be sent to the Chief Information Officer, U.S. Patent and Trademark Office, U.S. Department of Commerce, P.O. Box 1450, Alexandria, VA 22313-1450. DO NOT SEND FEES OR COMPLETED FORMS TO THIS ADDRESS. **SEND TO: Commissioner for Patents, P.O. Box 1450, Alexandria, VA 22313-1450.**
 If you need assistance in completing the form, call 1-800-PTO-9199 and select option 2.



UNITED STATES PATENT AND TRADEMARK OFFICE

UNITED STATES DEPARTMENT OF COMMERCE
United States Patent and Trademark Office
Address: COMMISSIONER FOR PATENTS
P.O. Box 1450
Alexandria, Virginia 22313-1450
www.uspto.gov

APPLICATION NO.	FILING DATE	FIRST NAMED INVENTOR	ATTORNEY DOCKET NO.	CONFIRMATION NO.
12/778,052	05/11/2010	John Douglas Steinberg	EFACT.007A	5650
20995	7590	06/17/2013	EXAMINER	
KNOBBE MARTENS OLSON & BEAR LLP			NORMAN, MARC E	
2040 MAIN STREET			ART UNIT	PAPER NUMBER
FOURTEENTH FLOOR			3744	
IRVINE, CA 92614			NOTIFICATION DATE	DELIVERY MODE
			06/17/2013	ELECTRONIC

Please find below and/or attached an Office communication concerning this application or proceeding.

The time period for reply, if any, is set in the attached communication.

Notice of the Office communication was sent electronically on above-indicated "Notification Date" to the following e-mail address(es):

jayna.cartee@knobbe.com
efiling@knobbe.com

Applicant-Initiated Interview Summary	Application No. 12/778,052	Applicant(s) STEINBERG ET AL.	
	Examiner MARC NORMAN	Art Unit 3744	

All participants (applicant, applicant's representative, PTO personnel):

(1) MARC NORMAN. (3) John Steinberg.
(2) John King. (4) _____.

Date of Interview: 11 June 2013.

Type: Telephonic Video Conference
 Personal [copy given to: applicant applicant's representative]

Exhibit shown or demonstration conducted: Yes No.
If Yes, brief description: _____.

Issues Discussed 101 112 102 103 Others
(For each of the checked box(es) above, please describe below the issue and detailed description of the discussion)

Claim(s) discussed: 1.

Identification of prior art discussed: _____.

Substance of Interview
(For each issue discussed, provide a detailed description and indicate if agreement was reached. Some topics may include: identification or clarification of a reference or a portion thereof, claim interpretation, proposed amendments, arguments of any applied references etc...)

Discussed proposed amendments to overcome the rejections under 35 USC 101. In addition to Applicant's proposed amendments (see attached), it was agreed to add language at the end of the claim reciting "logging said manual change to a database of the thermostatic controller".

Applicant recordation instructions: The formal written reply to the last Office action must include the substance of the interview. (See MPEP section 713.04). If a reply to the last Office action has already been filed, applicant is given a non-extendable period of the longer of one month or thirty days from this interview date, or the mailing date of this interview summary form, whichever is later, to file a statement of the substance of the interview

Examiner recordation instructions: Examiners must summarize the substance of any interview of record. A complete and proper recordation of the substance of an interview should include the items listed in MPEP 713.04 for complete and proper recordation including the identification of the general thrust of each argument or issue discussed, a general indication of any other pertinent matters discussed regarding patentability and the general results or outcome of the interview, to include an indication as to whether or not agreement was reached on the issues raised.

Attachment

/Marc E. Norman/
Primary Examiner, Art Unit 3744

Summary of Record of Interview Requirements

Manual of Patent Examining Procedure (MPEP), Section 713.04, Substance of Interview Must be Made of Record

A complete written statement as to the substance of any face-to-face, video conference, or telephone interview with regard to an application must be made of record in the application whether or not an agreement with the examiner was reached at the interview.

Title 37 Code of Federal Regulations (CFR) § 1.133 Interviews Paragraph (b)

In every instance where reconsideration is requested in view of an interview with an examiner, a complete written statement of the reasons presented at the interview as warranting favorable action must be filed by the applicant. An interview does not remove the necessity for reply to Office action as specified in §§ 1.111, 1.135. (35 U.S.C. 132)

37 CFR §1.2 Business to be transacted in writing.

All business with the Patent or Trademark Office should be transacted in writing. The personal attendance of applicants or their attorneys or agents at the Patent and Trademark Office is unnecessary. The action of the Patent and Trademark Office will be based exclusively on the written record in the Office. No attention will be paid to any alleged oral promise, stipulation, or understanding in relation to which there is disagreement or doubt.

The action of the Patent and Trademark Office cannot be based exclusively on the written record in the Office if that record is itself incomplete through the failure to record the substance of interviews.

It is the responsibility of the applicant or the attorney or agent to make the substance of an interview of record in the application file, unless the examiner indicates he or she will do so. It is the examiner's responsibility to see that such a record is made and to correct material inaccuracies which bear directly on the question of patentability.

Examiners must complete an Interview Summary Form for each interview held where a matter of substance has been discussed during the interview by checking the appropriate boxes and filling in the blanks. Discussions regarding only procedural matters, directed solely to restriction requirements for which interview recordation is otherwise provided for in Section 812.01 of the Manual of Patent Examining Procedure, or pointing out typographical errors or unreadable script in Office actions or the like, are excluded from the interview recordation procedures below. Where the substance of an interview is completely recorded in an Examiners Amendment, no separate Interview Summary Record is required.

The Interview Summary Form shall be given an appropriate Paper No., placed in the right hand portion of the file, and listed on the "Contents" section of the file wrapper. In a personal interview, a duplicate of the Form is given to the applicant (or attorney or agent) at the conclusion of the interview. In the case of a telephone or video-conference interview, the copy is mailed to the applicant's correspondence address either with or prior to the next official communication. If additional correspondence from the examiner is not likely before an allowance or if other circumstances dictate, the Form should be mailed promptly after the interview rather than with the next official communication.

The Form provides for recordation of the following information:

- Application Number (Series Code and Serial Number)
- Name of applicant
- Name of examiner
- Date of interview
- Type of interview (telephonic, video-conference, or personal)
- Name of participant(s) (applicant, attorney or agent, examiner, other PTO personnel, etc.)
- An indication whether or not an exhibit was shown or a demonstration conducted
- An identification of the specific prior art discussed
- An indication whether an agreement was reached and if so, a description of the general nature of the agreement (may be by attachment of a copy of amendments or claims agreed as being allowable). Note: Agreement as to allowability is tentative and does not restrict further action by the examiner to the contrary.
- The signature of the examiner who conducted the interview (if Form is not an attachment to a signed Office action)

It is desirable that the examiner orally remind the applicant of his or her obligation to record the substance of the interview of each case. It should be noted, however, that the Interview Summary Form will not normally be considered a complete and proper recordation of the interview unless it includes, or is supplemented by the applicant or the examiner to include, all of the applicable items required below concerning the substance of the interview.

A complete and proper recordation of the substance of any interview should include at least the following applicable items:

- 1) A brief description of the nature of any exhibit shown or any demonstration conducted,
- 2) an identification of the claims discussed,
- 3) an identification of the specific prior art discussed,
- 4) an identification of the principal proposed amendments of a substantive nature discussed, unless these are already described on the Interview Summary Form completed by the Examiner,
- 5) a brief identification of the general thrust of the principal arguments presented to the examiner,
(The identification of arguments need not be lengthy or elaborate. A verbatim or highly detailed description of the arguments is not required. The identification of the arguments is sufficient if the general nature or thrust of the principal arguments made to the examiner can be understood in the context of the application file. Of course, the applicant may desire to emphasize and fully describe those arguments which he or she feels were or might be persuasive to the examiner.)
- 6) a general indication of any other pertinent matters discussed, and
- 7) if appropriate, the general results or outcome of the interview unless already described in the Interview Summary Form completed by the examiner.

Examiners are expected to carefully review the applicant's record of the substance of an interview. If the record is not complete and accurate, the examiner will give the applicant an extendable one month time period to correct the record.

Examiner to Check for Accuracy

If the claims are allowable for other reasons of record, the examiner should send a letter setting forth the examiner's version of the statement attributed to him or her. If the record is complete and accurate, the examiner should place the indication, "Interview Record OK" on the paper recording the substance of the interview along with the date and the examiner's initials.



UNITED STATES PATENT AND TRADEMARK OFFICE

UNITED STATES DEPARTMENT OF COMMERCE
United States Patent and Trademark Office
Address: COMMISSIONER FOR PATENTS
P.O. Box 1450
Alexandria, Virginia 22313-1450
www.uspto.gov

Table with 5 columns: APPLICATION NO., FILING DATE, FIRST NAMED INVENTOR, ATTORNEY DOCKET NO., CONFIRMATION NO.
Row 1: 12/778,052, 05/11/2010, John Douglas Steinberg, EFACT.007A, 5650
Row 2: 20995, 7590, 05/07/2013, KNOBBE MARTENS OLSON & BEAR LLP, 2040 MAIN STREET, FOURTEENTH FLOOR, IRVINE, CA 92614, EXAMINER NORMAN, MARC E, ART UNIT 3744, PAPER NUMBER, NOTIFICATION DATE 05/07/2013, DELIVERY MODE ELECTRONIC

Please find below and/or attached an Office communication concerning this application or proceeding.

The time period for reply, if any, is set in the attached communication.

Notice of the Office communication was sent electronically on above-indicated "Notification Date" to the following e-mail address(es):

jayna.cartee@knobbe.com
efiling@knobbe.com

DETAILED ACTION

Claim Rejections - 35 USC § 101

35 U.S.C. 101 reads as follows:

Whoever invents or discovers any new and useful process, machine, manufacture, or composition of matter, or any new and useful improvement thereof, may obtain a patent therefor, subject to the conditions and requirements of this title.

Claims 1-8 are rejected under 35 U.S.C. 101 because the claimed invention is directed to non-statutory subject matter.

Claim 1 recites a method comprising accessing stored data, predicting a rate of change, calculating scheduled programming, comparing setpoints, and detecting manual changes based on the comparison. The accessing of stored data is considered insignificant pre-solution activity. All of these steps are thus considered abstract calculations that do not require the method be implemented by a particular machine and does not transform a particular article, And thus is not eligible subject matter under 35 USC 101.

While claims 2-8 recite various details of the controller device, processor, etc., these are structural features that are external to the actual method for detecting manual changes, and thus do not render the claims as having eligible subject matter under 35 USC 101.

Allowable Subject Matter

Claims 9-23 are allowed.

Conclusion

Any inquiry concerning this communication or earlier communications from the examiner should be directed to MARC NORMAN whose telephone number is (571)272-4812. The examiner can normally be reached on Mon.-Fri., 8:30-5:00.

If attempts to reach the examiner by telephone are unsuccessful, the examiner's supervisor, Cheryl Tyler can be reached on 571-272-4834. The fax phone number for the organization where this application or proceeding is assigned is 571-273-8300.

Information regarding the status of an application may be obtained from the Patent Application Information Retrieval (PAIR) system. Status information for published applications may be obtained from either Private PAIR or Public PAIR. Status information for unpublished applications is available through Private PAIR only. For more information about the PAIR system, see <http://pair-direct.uspto.gov>. Should you have questions on access to the Private PAIR system, contact the Electronic Business Center (EBC) at 866-217-9197 (toll-free). If you would like assistance from a USPTO Customer Service Representative or access to the automated information system, call 800-786-9199 (IN USA OR CANADA) or 571-272-1000.

/Marc E. Norman/
Primary Examiner, Art Unit 3744

Notice of References Cited	Application/Control No. 12/778,052	Applicant(s)/Patent Under Reexamination STEINBERG ET AL.	
	Examiner MARC NORMAN	Art Unit 3744	Page 1 of 1

U.S. PATENT DOCUMENTS

*	Document Number Country Code-Number-Kind Code	Date MM-YYYY	Name	Classification
*	A US-6,454,177 B1	09-2002	Sasao et al.	236/46R
*	B US-4,897,798	01-1990	Cler, Lawrence J.	700/276
	C US-			
	D US-			
	E US-			
	F US-			
	G US-			
	H US-			
	I US-			
	J US-			
	K US-			
	L US-			
	M US-			

FOREIGN PATENT DOCUMENTS

*	Document Number Country Code-Number-Kind Code	Date MM-YYYY	Country	Name	Classification
	N				
	O				
	P				
	Q				
	R				
	S				
	T				

NON-PATENT DOCUMENTS

*	Include as applicable: Author, Title Date, Publisher, Edition or Volume, Pertinent Pages)
U	
V	
W	
X	

*A copy of this reference is not being furnished with this Office action. (See MPEP § 707.05(a).)
Dates in MM-YYYY format are publication dates. Classifications may be US or foreign.

Date received: 3/23/11 /MN/

PTO/SB/08 Equivalent

INFORMATION DISCLOSURE STATEMENT BY APPLICANT	Application No.	12/778052
	Filing Date	05-11-2010
	First Named Inventor	Steinberg, John Douglas et al
	Art Unit	3744
<i>(Multiple sheets used when necessary)</i>		Examiner
SHEET 1 OF 1		Attorney Docket No. EFACT.007A

U.S. PATENT DOCUMENTS					
Examiner Initials	Cite No.	Document Number Number - Kind Code (if known) Example: 1,234,567 B1	Publication Date MM-DD-YYYY	Name of Patentee or Applicant	Pages, Columns, Lines Where Relevant Passages or Relevant Figures Appear
	1	5,682,949	11-04-1997	Ratcliffe et al.	
	2	5,818,347	10-06-1998	Dolan et al.	
	3	5,977,964	11-1999	Williams et al.	
	4	6,912,429	06-2005	Bilger	
	5	7,061,393	06-2006	Buckingham et al.	
	6	7,242,988	07-2007	Hoffberg et al.	
	7	7,260,823	08-2007	Schlack et al.	
	8	7,483,964	01-2009	Jackson et al.	
	9	H2176	12-2006	Meyer et al.	
	10	2006/0045105 A1	03-2006	Dobosz et al.	
	11	2007/0146126 A1	06-2007	Wang	
	12	2008/0281472 A1	11-2008	Podgorny et al.	
	13	2009/0052859 A 1	02-2009	Greenberger et al.	
	14	2010/0156608 A1	06-2010	BAE et al.	
	15	2010/0162285 A1	06-2010	Cohen et al.	

FOREIGN PATENT DOCUMENTS						
Examiner Initials	Cite No.	Foreign Patent Document Country Code-Number-Kind Code Example: JP 1234567 A1	Publication Date MM-DD-YYYY	Name of Patentee or Applicant	Pages, Columns, Lines Where Relevant Passages or Relevant Figures Appear	T ¹

NON PATENT LITERATURE DOCUMENTS			
Examiner Initials	Cite No.	Include name of the author (in CAPITAL LETTERS), title of the article (when appropriate), title of the item (book, magazine, journal, serial, symposium, catalog, etc.), date, page(s), volume-issue number(s), publisher, city and/or country where published.	T ¹
	16	Honeywell, "W7600/W7620 Controller Reference Manual, HW0021207, October, 1992	
	17	PIER, Southern California Edison, Demand Responsive Control of Air Conditioning via Programmable Communicating Thermostats Draft Report	
	18	WETTER, et al., A comparison of deterministic and probabilistic optimization algorithms for nonsmooth simulation-based optimization., Building and Environment 39, 2004, Pages 989-999	

Note: crossed-out reference not considered because no corresponding date provided.

10922450
032111

/MN/

Examiner Signature	/Marc Norman/	Date Considered	04/16/2013
*Examiner: Initial if reference considered, whether or not citation is in conformance with MPEP 609. Draw line through citation if not in conformance and not considered. Include copy of this form with next communication to applicant.			

T¹ - Place a check mark in this area when an English Language Translation is attached. ALL REFERENCES CONSIDERED EXCEPT WHERE LINED THROUGH. /MN/

<i>Index of Claims</i> 	Application/Control No. 12778052	Applicant(s)/Patent Under Reexamination STEINBERG ET AL.
	Examiner MARC NORMAN	Art Unit 3744

✓	Rejected	-	Cancelled	N	Non-Elected	A	Appeal
=	Allowed	÷	Restricted	I	Interference	O	Objected

Claims renumbered in the same order as presented by applicant
 CPA
 T.D.
 R.1.47

CLAIM		DATE									
Final	Original	04/16/2013									
	1	✓									
	2	✓									
	3	✓									
	4	✓									
	5	✓									
	6	✓									
	7	✓									
	8	✓									
	9	=									
	10	=									
	11	=									
	12	=									
	13	=									
	14	=									
	15	=									
	16	=									
	17	=									
	18	=									
	19	=									
	20	=									
	21	=									
	22	=									
	23	=									

Search Notes 	Application/Control No. 12778052	Applicant(s)/Patent Under Reexamination STEINBERG ET AL.
	Examiner MARC NORMAN	Art Unit 3744

CPC- SEARCHED		
Symbol	Date	Examiner

CPC COMBINATION SETS - SEARCHED		
Symbol	Date	Examiner

US CLASSIFICATION SEARCHED			
Class	Subclass	Date	Examiner
236	1C, 46R, 51, 94	4/16/13	MN
62	161, 163	4/16/13	MN
700	276, 278	4/16/13	MN

SEARCH NOTES		
Search Notes	Date	Examiner
EAST search (interior/inside/indoor temperature; exterior/outside/outdoor temperature; rate of change; setpoint; time; manual; automatic; etc.); inventor name search	4/16/13	MN

INTERFERENCE SEARCH			
US Class/ CPC Symbol	US Subclass / CPC Group	Date	Examiner

--	--

Date received: 2/27/13 /MN/

PTO/SB/08 Equivalent

INFORMATION DISCLOSURE STATEMENT BY APPLICANT	Application No.	12/778052	
	Filing Date	05-11-2010	
	First Named Inventor	Steinberg, John Douglas et al	
	Art Unit	3744	
<i>(Multiple sheets used when necessary)</i>		Examiner	Unknown
SHEET 1 OF 3		Attorney Docket No.	EFACT.007A

U.S. PATENT DOCUMENTS					
Examiner Initials	Cite No.	Document Number Number - Kind Code (if known) Example: 1,234,567 B1	Publication Date MM-DD-YYYY	Name of Patentee or Applicant	Pages, Columns, Lines Where Relevant Passages or Relevant Figures Appear
	1	4,136,732	01-1979	Demaray et al.	
	2	4,341,345	07-1982	Hammer et al.	
	3	4,475,685	10-1984	Grimado, et al.	
	4	4,655,279	04-1987	Harmon	
	5	5,244,146	09-1993	Jefferson et al.	
	6	5,270,952	12-1993	Adams et al.	
	7	5,314,004	05-1994	Strand et al.	
	8	5,462,225	10-1995	Massara et al.	
	9	5,544,036	08-1996	Brown et al.	
	10	5,555,927	09-1996	Shah	
	11	6,115,713	09-05-2000	Pascucci, et al.	
	12	6,260,765	07-2001	Natale et al.	
	13	7,356,384	04-2008	Gull, et al.	
	14	7,644,869	01-2010	Hoglund et al.	
	15	7,784,704	08-31-2010	Harter	
	16	7,848,900	12-07-2010	Steinberg, John Douglas et al.	
	17	7,894,943	02-22-2011	Sloup et al.	
	18	7,908,116	03-15-2011	Steinberg, John Douglas et al.	
	19	7,908,117	03-15-2011	Steinberg, John Douglas et al.	
	20	8,010,237	08-30-2011	Cheung, Leo et al.	
	21	8,019,567	09-13-2011	Steinberg, John Douglas et al.	
	22	8,090,477	01-03-2012	Steinberg, John Douglas	
	23	8,131,497	03-06-2012	Steinberg, John Douglas et al.	
	24	8,131,506	03-06-2012	Steinberg, John Douglas et al.	
	25	8,180,492	05-15-2012	Steinberg, John Douglas	
	26	8,340,826	12-25-2012	Steinberg, John Douglas	
	27	13/523,697	06-14-2012	Hublou, et al.	
	28	13/725,447	12-21-2012	Steinberg, John Douglas	
	29	2004/0176880	09-09-2004	Obradovich, et al.	

Examiner Signature	/Marc Norman/	Date Considered	04/16/2013
<p>*Examiner: Initial if reference considered, whether or not citation is in conformance with MPEP 609. Draw line through citation if not in conformance and not considered. Include copy of this form with next communication to applicant.</p>			

T¹ - Place a check mark in this area when an English language translation is attached. **ALL REFERENCES CONSIDERED EXCEPT WHERE LINED THROUGH.** /MN/

INFORMATION DISCLOSURE STATEMENT BY APPLICANT	Application No.	12/778052
	Filing Date	05-11-2010
	First Named Inventor	Steinberg, John Douglas et al
	Art Unit	3744
(Multiple sheets used when necessary)	Examiner	Unknown
SHEET 2 OF 3	Attorney Docket No.	EFACT.007A

U.S. PATENT DOCUMENTS					
Examiner Initials	Cite No.	Document Number Number - Kind Code (if known) Example: 1,234,567 B1	Publication Date MM-DD-YYYY	Name of Patentee or Applicant	Pages, Columns, Lines Where Relevant Passages or Relevant Figures Appear
	30	2006/0214014	09-28-2006	Bash, et al.	
	31	2007/0045431	03-03-2007	Chapman, et al.	
	32	2008/0198549	08-21-2008	Rasmussen, et al.	
	33	2009/0240381	09-2009	Lane	
	34	2009/0281667	11-2009	Masui, et al.	
	35	2010/0019052	01-2010	Yip	
	36	2010/0070086	03-2010	Harrod, et al.	
	37	2010/0070089	03-2010	Harrod, et al.	
	38	2010/0070093	03-2010	Harrod, et al.	
	39	2010/0211224	08-2010	Keeling, et al.	
	40	2010/0235004	09-2010	Thind	
	41	2010/0282857	11-11-2010	Steinberg	
	42	2010/0289643	11-2010	Trundle, et al.	
	43	2010/0308119	12-09-2010	Steinberg, et al.	
	44	2010/0318227	12-16-2010	Steinberg, et al.	
	45	2011/0031323	02-2011	Nold, et al.	
	46	2011/0290893	12-01-2011	Steinberg	
	47	2011/0307103	12-15-2011	Cheung, et al.	
	48	2012/0065935	03-15-2012	Steinberg, et al.	
	49	2012/0086562	04-12-2012	Steinberg	
	50	2012/0158350	06-21-2012	Steinberg, et al.	
	51	2012/0221151 A1	08-30-2012	Steinberg, John Douglas	
	52	2012/0221294 A1	08-30-2012	Steinberg, John Douglas et al.	

FOREIGN PATENT DOCUMENTS						
Examiner Initials	Cite No.	Foreign Patent Document Country Code-Number-Kind Code Example: JP 1234567 A1	Publication Date MM-DD-YYYY	Name of Patentee or Applicant	Pages, Columns, Lines Where Relevant Passages or Relevant Figures Appear	T ¹
	53	EP 0415747	03-06-1991	Shaw, et al.		
	54	KR 10-1994-0011902	06-22-1994	Koryo Digital Elect. Co.		

Examiner Signature	/Marc Norman/	Date Considered	04/16/2013
<p>*Examiner: Initial if reference considered, whether or not citation is in conformance with MPEP 609. Draw line through citation if not in conformance and not considered. Include copy of this form with next communication to applicant.</p>			

T¹ - Place a check mark in this area when an English language translation is attached.

ALL REFERENCES CONSIDERED EXCEPT WHERE LINED THROUGH. /MN/

INFORMATION DISCLOSURE STATEMENT BY APPLICANT	Application No.	12/778052
	Filing Date	05-11-2010
	First Named Inventor	Steinberg, John Douglas et al
	Art Unit	3744
<i>(Multiple sheets used when necessary)</i>	Examiner	Unknown
SHEET 3 OF 3	Attorney Docket No.	EFACT.007A

FOREIGN PATENT DOCUMENTS						
Examiner Initials	Cite No.	Foreign Patent Document Country Code-Number-Kind Code Example: JP 1234567 A1	Publication Date MM-DD-YYYY	Name of Patentee or Applicant	Pages, Columns, Lines Where Relevant Passages or Relevant Figures Appear	T ¹
	55	KR 10-2000-0059532	10-05-2000	Dang Hae System Co.		

NON PATENT LITERATURE DOCUMENTS			
Examiner Initials	Cite No.	Include name of the author (in CAPITAL LETTERS), title of the article (when appropriate), title of the item (book, magazine, journal, serial, symposium, catalog, etc.), date, page(s), volume-issue number(s), publisher, city and/or country where published.	T ¹
	56	Bourhan, et al., "Dynamic model of an HVAC system for control analysis", Elsevier 2004	
	57	Emerson Climate Technologies, "Network Thermostat for E2 Building Controller Installation and Operation Manual", 2007	
	58	Johnson Controls, "T600HCx-3 Single-Stage Thermostats", 2006	
	59	Written Opinion and Search Report for PCT/US2011/032537, dated 12/12/11 (our reference EFACT.012WO)	
	60	Comverge SuperStat Flyer, prior to June 28, 2007	
	61	Control4 Wireless Thermostat Brochure, 2006	
	62	Cooper Power Systems Web Page, 2000-2009	
	63	Enernoc Web Page, 2004-2009	
	64	Enerwise Website, 1999-2009	
	65	Honeywell Programmable Thermostat Owner's Guide, www.honeywell.com/yourhome, 2004	
	66	PIER, Southern California Edison, Demand Responsive Control of Air Conditioning via Programmable Communicating; February 14, 2006	
	67	Proliphix Thermostat Brochure, prior to June 2007	

14876325:ad
022013

Examiner Signature	/Marc Norman/	Date Considered	04/16/2013
*Examiner: Initial if reference considered, whether or not citation is in conformance with MPEP 609. Draw line through citation if not in conformance and not considered. Include copy of this form with next communication to applicant.			

T¹ - Place a check mark in this area when an ~~English Language Translation~~ ~~Patent~~ ~~is~~ ~~attached~~.
ALL REFERENCES CONSIDERED EXCEPT WHERE LINED THROUGH. /MN/

UNITED STATES PATENT AND TRADEMARK OFFICE

UNITED STATES DEPARTMENT OF COMMERCE
United States Patent and Trademark Office
 Address: COMMISSIONER FOR PATENTS
 P.O. Box 1450
 Alexandria, Virginia 22313-1450
 www.uspto.gov

BIB DATA SHEET
CONFIRMATION NO. 5650

SERIAL NUMBER	FILING or 371(c) DATE	CLASS	GROUP ART UNIT	ATTORNEY DOCKET NO.		
12/778,052	05/11/2010	236	3744	EFACT.007A		
APPLICANTS						
John Douglas Steinberg, Millbrae, CA; Scott Douglas Hublou, Redwood City, CA; Leo Cheung, Sunnyvale, CA;						
** CONTINUING DATA ***** This appln claims benefit of 61/215,999 05/12/2009						
** FOREIGN APPLICATIONS *****						
** IF REQUIRED, FOREIGN FILING LICENSE GRANTED ** ** SMALL ENTITY ** 05/28/2010						
Foreign Priority claimed <input type="checkbox"/> Yes <input checked="" type="checkbox"/> No	35 USC 119(a-d) conditions met <input type="checkbox"/> Yes <input checked="" type="checkbox"/> No	<input type="checkbox"/> Met after Allowance	STATE OR COUNTRY	SHEETS DRAWINGS	TOTAL CLAIMS	INDEPENDENT CLAIMS
Verified and Acknowledged	/MARC E NORMAN/ Examiner's Signature	Initials	CA	11	23	3
ADDRESS						
KNOBBE MARTENS OLSON & BEAR LLP 2040 MAIN STREET FOURTEENTH FLOOR IRVINE, CA 92614 UNITED STATES						
TITLE						
SYSTEM, METHOD AND APPARATUS FOR IDENTIFYING MANUAL INPUTS TO AND ADAPTIVE PROGRAMMING OF A THERMOSTAT						
FILING FEE RECEIVED	FEES: Authority has been given in Paper No. _____ to charge/credit DEPOSIT ACCOUNT No. _____ for following:			<input type="checkbox"/> All Fees <input type="checkbox"/> 1.16 Fees (Filing) <input type="checkbox"/> 1.17 Fees (Processing Ext. of time) <input type="checkbox"/> 1.18 Fees (Issue) <input type="checkbox"/> Other _____ <input type="checkbox"/> Credit		
605						

Date received: 5/11/10

/MN/

PTO/SB/08 Equivalent

INFORMATION DISCLOSURE STATEMENT BY APPLICANT	Application No.	Unknown
	Filing Date	Herewith
	First Named Inventor	Steinberg, John Douglas et al
	Art Unit	
<i>(Multiple sheets used when necessary)</i>		Examiner
SHEET 1 OF 4		Attorney Docket No. EFACT.007A

U.S. PATENT DOCUMENTS					
Examiner Initials	Cite No.	Document Number Number - Kind Code (if known) Example: 1,234,567 B1	Publication Date MM-DD-YYYY	Name of Patentee or Applicant	Pages, Columns, Lines Where Relevant Passages or Relevant Figures Appear
	1	4,403,644	09-13-1983	Raymond T.	
	2	4,674,027	06-16-1987	Beckey	
	3	5,572,438	11-05-1996	Ehlers, et al.	
	4	5,717,609	02-10-1998	Packa, et al.	
	5	6,145,751	11-14-2000	Ahmed	
	6	6,178,362	01-23-2001	Woolard, et al.	
	7	6,351,693	02-26-2002	Monie	
	8	6,400,996	06-04-2002	Hoffberg, et al.	
	9	6,437,692	08-20-2002	Petite, et al.	
	10	6,478,233	11-12-2002	Shah	
	11	6,480,803	11-12-2002	Pierret, et al.	
	12	6,483,906	11-19-2002	Lggulden, et al.	
	13	6,536,675	03-25-2003	Pesko, et al.	
	14	6,542,076	04-01-2003	Joao	
	15	6,549,130	04-15-2003	Joao	
	16	6,574,537	06-02-2003	Kipersztok, et al.	
	17	6,580,950	06-17-2003	Johnson	
	18	6,594,825	07-15-2003	Goldschmidtli, et al.	
	19	6,595,430	07-22-2003	Shah	
	20	6,598,056	07-22-2003	Hull, et al.	
	21	6,619,555	09-16-2003	Rosen	
	22	6,622,097	09-16-2003	Hunter	
	23	6,622,115	09-16-2003	Brown, et al.	
	24	6,622,925	09-23-2003	Carner, et al.	
	25	6,622,926	09-23-2003	Sartain, et al.	
	26	6,628,997	09-30-2003	Fox, et al.	
	27	6,633,823	10-14-2003	Bartone, et al.	
	28	6,643,567	11-04-2003	Kolk et al.	
	29	6,671,586	12-30-2003	Davis, et al.	

Examiner Signature	/Marc Norman/	Date Considered	04/16/2013
<p>*Examiner: Initial if reference considered, whether or not citation is in conformance with MPEP 609. Draw line through citation if not in conformance and not considered. Include copy of this form with next communication to applicant.</p>			

T¹ - Place a check mark in this area when an English language translation is attached. **ALL REFERENCES CONSIDERED EXCEPT WHERE LINED THROUGH.** /MN/

INFORMATION DISCLOSURE STATEMENT BY APPLICANT	Application No.	Unknown
	Filing Date	Herewith
	First Named Inventor	Steinberg, John Douglas et al
	Art Unit	
<i>(Multiple sheets used when necessary)</i>		Examiner
SHEET 2 OF 4		Attorney Docket No. EFACT.007A

U.S. PATENT DOCUMENTS					
Examiner Initials	Cite No.	Document Number <i>Number - Kind Code (if known)</i> Example: 1,234,567 B1	Publication Date MM-DD-YYYY	Name of Patentee or Applicant	Pages, Columns, Lines Where Relevant Passages or Relevant Figures Appear
	30	6,695,218	02-24-2004	Fleckenstein	
	31	6,726,113	04-27-2004	Guo	
	32	6,731,992	05-04-2004	Ziegler	
	33	6,734,806	05-11-2004	Cratsley	
	34	6,772,052	08-03-2004	Amundsen	
	35	6,785,592	08-31-2004	Smith	
	36	6,785,630	08-31-2004	Kolk	
	37	6,789,739	09-14-2004	Rosen	
	38	6,853,959	02-08-2005	Ikeda, et al.	
	39	6,868,293	03-15-2005	Schurr	
	40	6,868,319	03-15-2005	Kipersztok, et al.	
	41	6,882,712	04-19-2005	Iggulden, et al.	
	42	6,889,908	05-10-2005	Crippen, et al.	
	43	6,891,838	10-10-2005	Petite, et al.	
	44	6,991,029	01-31-2006	Orfield, et al.	
	45	7,009,493	03-07-2006	Howard	
	46	7,031,880	04-18-2006	Seem, et al.	
	47	7,039,532	05-02-2006	Hunter	
	48	7,089,088	08-08-2006	Terry, et al.	
	49	7,130,719	10-31-2006	Ehlers, et al.	
	50	7,130,832	10-31-2006	Bannai, et al.	
	51	7,167,079	01-23-2007	Smyth, et al.	
	52	7,187,986	03-06-2007	Johnson, et al.	
	53	7,205,892	04-17-2007	Luebke, et al.	
	54	7,215,746	05-08-2007	Iggulden, et al.	
	55	7,216,015	05-08-2007	Poth, Robert J.	
	56	7,231,424	06-11-2007	Bodin, et al.	
	57	7,232,075	06-19-2007	Rosen	
	58	2003/0040934 A1	02-27-2003	Skidmore, et al.	

Examiner Signature /Marc Norman/	Date Considered 04/16/2013
*Examiner: Initial if reference considered, whether or not citation is in conformance with MPEP 609. Draw line through citation if not in conformance and not considered. Include copy of this form with next communication to applicant.	

T¹ - Place a check mark in this area when an English language translation is attached. **ALL REFERENCES CONSIDERED EXCEPT WHERE LINED THROUGH. /MN/**

INFORMATION DISCLOSURE STATEMENT BY APPLICANT	Application No.	Unknown
	Filing Date	Herewith
	First Named Inventor	Steinberg, John Douglas et al
	Art Unit	
<i>(Multiple sheets used when necessary)</i>		Examiner
SHEET 3 OF 4		Attorney Docket No. EFACT.007A

U.S. PATENT DOCUMENTS					
Examiner Initials	Cite No.	Document Number Number - Kind Code (if known) Example: 1,234,567 B1	Publication Date MM-DD-YYYY	Name of Patentee or Applicant	Pages, Columns, Lines Where Relevant Passages or Relevant Figures Appear
	59	2005/0222889 A1	10-06-2005	Lai, et al.	
	60	2005/0288822 A1	12-29-2005	Rayburn	
	61	2007/0043477 A1	02-22-2007	Elhers, et al.	
	62	2008/0083234 A1	04-10-2008	Krebs, et al.	
	63	2009/0099699 A1	04-16-2009	Steinberg, et al.	
	64	2009/0125151 A1	05-14-2009	Steinberg, et al.	

NON PATENT LITERATURE DOCUMENTS			
Examiner Initials	Cite No.	Include name of the author (in CAPITAL LETTERS), title of the article (when appropriate), title of the item (book, magazine, journal, serial, symposium, catalog, etc.), date, page(s), volume-issue number(s), publisher, city and/or country where published.	T ¹
	65	ARENS, et al., "How Ambient Intelligence Will Improve Habitability and Energy Efficiency in Buildings", 2005, research paper, Center for the Built Environment, Controls and Information Technology	
	66	Converge SuperStat Flyer	
	67	Control4 Wireless Thermostat Brochure	
	68	Cooper Power Systems Web Page	
	69	Enernoc Web Page	
	70	Enervise Website	
	71	Honeywell Programmable Thermostat Owner's Guide, www.honeywell.com/yourhome	
	72	JOHNSON CONTROLS, Touch4 building automation system brochure, 2007	
	73	KILICOTTE, et al., "Dynamic Controls for Energy Efficiency and Demand Response: Framework Concepts and a New Construction Study Case in New York", Proceedings of the 2006 ACEEE Summer Study of Energy Efficiency in Buildings, Pacific Grove, CA, August 13-18, 2006	
	74	LIN, et al., "Multi-Sensor Single-Actuator Control of HVAC Systems", 2002	
	75	PIER, Southern California Edison, Demand Responsive Control of Air Conditioning via Programmable Communicating Thermostats Draft Report	
	76	Dolphix Thermostat Brochure	

Examiner Signature	/Marc Norman/	Date Considered	04/16/2013
--------------------	---------------	-----------------	------------

*Examiner: Initial if reference considered, whether or not citation is in conformance with MPEP 609. Draw line through citation if not in conformance and not considered. Include copy of this form with next communication to applicant.

T¹ - Place a check mark in this area when an English language translation is attached. **ALL REFERENCES CONSIDERED EXCEPT WHERE LINED THROUGH. /MN/**

INFORMATION DISCLOSURE STATEMENT BY APPLICANT	Application No.	Unknown
	Filing Date	Herewith
	First Named Inventor	Steinberg, John Douglas et al
	Art Unit	
<i>(Multiple sheets used when necessary)</i>	Examiner	
SHEET 4 OF 4	Attorney Docket No.	EFACT.007A

NON PATENT LITERATURE DOCUMENTS			
Examiner Initials	Cite No.	Include name of the author (in CAPITAL LETTERS), title of the article (when appropriate), title of the item (book, magazine, journal, serial, symposium, catalog, etc.), date, page(s), volume-issue number(s), publisher, city and/or country where published.	T ¹
	77	WANG, et al., "Opportunities to Save Energy and Improve Comfort by Using Wireless Sensor Networks in Buildings," (2003), Center for Environmental Design Research	
	78	WETTER, et al., "A comparison of deterministic and probabilistic optimization algorithms for nonsmooth simulation-based optimization", Building and Environment 39, 2004, Pages 989-999	

9016046:ad
050710

Note: crossed-out references not considered because no corresponding date provided.

/MN/

Examiner Signature	/Marc Norman/	Date Considered	04/16/2013
*Examiner: Initial if reference considered, whether or not citation is in conformance with MPEP 609. Draw line through citation if not in conformance and not considered. Include copy of this form with next communication to applicant.			

T¹ - Place a checkmark in this area when an English Language Translation is attached. ~~ALL REFERENCES CONSIDERED EXCEPT WHERE LINED THROUGH.~~ /MN/

IN THE UNITED STATES PATENT AND TRADEMARK OFFICE

Inventor	: Steinberg, et al.
App. No.	: 12/778,052
Filed	: May 11, 2010
For	: SYSTEM, METHOD AND APPARATUS FOR IDENTIFYING MANUAL INPUTS TO AND ADAPTIVE PROGRAMMING OF A THERMOSTAT
Examiner	: Unknown
Art Unit	: 3744
Conf No.	: 5650

PRELIMINARY AMENDMENT

Mail Stop Amendment

Commissioner for Patents
P.O. Box 1450
Alexandria, VA 22313-1450

Dear Sir:

Prior to the examination of the above-captioned application, please amend the application as follows:

Amendments to the Claims are reflected in the listing of claims which begins on page 2 of this paper.

Remarks/Arguments begin on page 6 of this paper.

Application No.: 12/778,052
Filing Date: May 11, 2010

AMENDMENTS TO THE CLAIMS

Please amend Claims 1, 9 and 17 as indicated below.

1. (Currently Amended) A method for detecting manual changes to the setpoint for a thermostatic controller comprising:

accessing stored data comprising a plurality of internal temperature measurements taken within a structure and a plurality of outside temperature measurements relating to temperatures outside the structure;

using the stored data to predict a rate of change of temperatures inside the structure in response to at least changes in outside temperatures;

calculating scheduled programming of the thermostatic controller for one or more times based on the predicted rate of change, the scheduled programming comprising at least a first automated setpoint at a first time;

comparing an actual setpoint at the first time for said thermostatic controller to the first automated setpoint for said thermostatic controller; and

detecting a manual change to the first automated setpoint by determining whether said actual setpoint and said first automated setpoint are the same or different.

2. (Original) A method as in Claim 1 where said thermostatic controller operates a system for changing the air temperature in a structure.

3. (Original) A method as in Claim 1 where said thermostatic controller operates a heating, ventilation and air conditioning system.

4. (Original) A method as in Claim 1 where said thermostatic controller operates a heating, ventilation and air conditioning system in a single family residence.

5. (Original) A method as in Claim 1 in which at least one remote processor is in communication with said thermostatic control device.

Application No.: 12/778,052
Filing Date: May 11, 2010

6. (Original) A method as in Claim 5 in which said remote processor is not located in the same structure as said thermostatic controller.

7. (Original) A method as in Claim 5 in which said remote processor sets programming for said thermostatic controller.

8. (Original) A method as in Claim 1 in which said thermostatic controller is programmable.

9. (Currently Amended) A method for incorporating manual changes to the setpoint for a thermostatic controller into long-term programming of said thermostatic controller comprising:

accessing stored data comprising a plurality of internal temperature measurements taken within a structure and a plurality of outside temperature measurements relating to temperatures outside the structure;

using the stored data to predict a rate of change of temperatures inside the structure in response to at least changes in outside temperatures;

calculating scheduled programming of setpoints in the thermostatic controller based on the predicted rate of change, the scheduled programming comprising at least a first automated setpoint at a first time and a second automated setpoint at a second time;

comparing the actual setpoint at the first time for said thermostatic controller to the first automated setpoint for said thermostatic controller ;

detecting a manual change to the first automated setpoint by determining whether said actual setpoint and said first automated setpoint are the same or different;

changing the second automated setpoint at the second time based on at least one rule for the interpretation of said manual change.

10. (Original) A method as in Claim 9 where said thermostatic controller operates a system for changing the air temperature in a structure.

Application No.: 12/778,052
Filing Date: May 11, 2010

11. (Original) A method as in Claim 9 where said thermostatic controller operates a heating, ventilation and air conditioning system.

12. (Original) A method as in Claim 9 where said thermostatic controller operates a heating, ventilation and air conditioning system in a single family residence.

13. (Original) A method as in Claim 9 in which at least one remote processor is in communication with said thermostatic control device.

14. (Original) A method as in Claim 13 in which said remote processor is not located in the same structure as said thermostatic controller.

15. (Original) A method as in Claim 13 in which said remote processor sets programming for said thermostatic controller.

16. (Original) A system as in Claim 9 in which said thermostatic controller is programmable.

17. (Currently Amended) An apparatus for detecting manual changes to the setpoint for a thennostatic controller comprising:

at least a programmable communicating thermostat;

at least a remote processor;

at least a network connecting said remote processor and said communicating;

at least a database comprising a plurality of internal temperature measurements taken within a structure and a plurality of outside temperature measurements relating to temperatures outside the structure;

computer hardware comprising one or more computer processors configured to use the stored data to predict a rate of change of temperatures inside the structure in response to changes in outside temperatures;

the one or more computer processors configured to calculate scheduled setpoint programming of the programmable communicating thermostat for one or

Application No.: 12/778,052
Filing Date: May 11, 2010

more times based on the predicted rate of change, the scheduled programming comprising one or more automated setpoints;

at least a database that stores the one or more automated setpoints associated with the scheduled programming for said programmable communicating thermostat;

at least a database that stores actual setpoint programming of said programmable communicating thermostat; and

the one or more computer processors configured to compare the one or more automated setpoints associated with said scheduled setpoint programming with said actual setpoint programming.

18. (Original) An apparatus as in claim 17 where said programmable communicating thermostat operates a system for changing the air temperature in a structure.

19. (Original) An apparatus as in claim 17 where said programmable communicating thermostat operates a heating, ventilation and air conditioning system.

20. (Original) An apparatus as in claim 17 where said programmable communicating thermostat operates a heating, ventilation and air conditioning system in a single family residence.

21. (Original) An apparatus as in claim 20 in which at least one remote processor is in communication with said programmable communicating thermostat.

22. (Original) An apparatus as in claim 20 in which said remote processor is not located in the same structure as said programmable communicating thermostat.

23. (Original) An apparatus as in claim 20 in which said remote processor sets programming for said programmable communicating thermostat.

Application No.: 12/778,052
Filing Date: May 11, 2010

REMARKS

In this Preliminary Amendment, Applicant has amended Claims 1, 9 and 17.

Support for the amendments can be found, by way of example in the publication of the pending application (U.S. Publication No. 2010/0308119) at paragraphs 0034-0037.

OTHER APPLICATIONS OF ASSIGNEE

Applicant wishes to draw the Examiner's attention to the following applications owned by of the present application's assignee:

Inventors	Appl. No.	Filing Date	Attorney Docket No.	Title
Steinberg et al.	60/963,183 Now Expired	08/03/07	EFACT.003PR	System And Method For Using A Network Of Thermostats As Tool To Verify Peak Demand Reduction
Steinberg et al.	60/944,011 Now Expired	09/17/07	EFACT.005PR	System And Method For Calculating The Thermal Mass Of A Building
Steinberg et al.	12/183,990 Now Pat. 7,908,117	07/31/08	EFACT.003A	System And Method For Using A Network Of Thermostats As Tool To Verify Peak Demand Reduction
Steinberg et al.	12/183,949 Now Pat. 7,908,116	07/31/08	EFACT.004A	System And Method For Using A Network Of Thermostats As Tool To Verify Peak Demand Reduction
Steinberg et al.	12/211,733 Now Pat. 7,848,900	09/16/08	EFACT.005A	System And Method For Calculating The Thermal Mass Of A Building
Steinberg et al.	12/211,690 Now Pat. 8,019,567	09/16/08	EFACT.006A	System And Method For Evaluating Changes In The Efficiency Of An HVAC System
Steinberg	61/215,816 Now Expired	05/11/09	EFACT.008PR	System, Method And Apparatus For Dynamically Variable Compressor Delay In Thermostat To Reduce Energy Consumption
Steinberg et al.	61/215,657 Now Expired	05/08/09	EFACT.009PR	System, Method And Apparatus For Just-In-Time Conditioning Using A Thermostat
Steinberg et al.	61/215,999 Now Expired	05/12/09	EFACT.007PR	System, Method And Apparatus For Identifying Manual Inputs To And Adaptive Programming Of A Thermostat

Application No.: 12/778,052
Filing Date: May 11, 2010

Inventors	Appl. No.	Filing Date	Attorney Docket No.	Title
Cheung et al.	12/498,142 Now Pat. 8,010,237	07/06/09	EFACT.010A	System And Method For Using Ramped Setpoint Temperature Variation With Networked Thermostats To Improve Efficiency
Steinberg	12/502,064 Now Pat. 8,180,492	07/13/09	EFACT.011A	System And Method For Using A Networked Electronic Device As An Occupancy Sensor For An Energy Management System
Steinberg et al.	12/773,690 Published 2010/0318227	05/04/10	EFACT.009A	System, Method And Apparatus For Just-In-Time Conditioning Using A Thermostat
Steinberg	12/774,580 Published 2010/0282857	05/05/10	EFACT.008A	System, Method And Apparatus For Dynamically Variable Compressor Delay In Thermostat To Reduce Energy Consumption
Steinberg et al.	12/778,052 Published 2010/0308119	05/11/10	EFACT.007A	System, Method And Apparatus For Identifying Manual Inputs To And Adaptive Programming Of A Thermostat
Steinberg	12/788,246 Published 2011/0290893	05/26/10	EFACT.012A	System And Method For Using A Mobile Electronic Device To Optimize An Energy Management System
Steinberg	12/860,821 Now Pat. 8,090,477	08/20/10	EFACT.013A	System And Method For Optimizing Use Of Plug-In Air Conditioners And Portable Heaters
Steinberg et al.	12/959,225 Now Pat. 8,131,497	12/02/10	EFACT.005C1	System And Method For Calculating The Thermal Mass Of A Building
Steinberg et al.	13/037,162 Now Pat. 8,131,506	02/28/11	EFACT.004C1	System And Method For Using A Network Of Thermostats As Tool To Verify Peak Demand Reduction
Cheung et al.	13/219,381 Published 2011/0307103	08/26/11	EFACT.010C1	System And Method For Using Ramped Setpoint Temperature Variation With Networked Thermostats To Improve Efficiency
Steinberg et al.	13/230,610 Published 2012/0065935	09/12/11	EFACT.006C1	System And Method For Evaluating Changes In The Efficiency Of An HVAC System
Steinberg	13/329,117 Now Pat. 8,340,826	12/16/11	EFACT.013C1	System And Method For Optimizing Use Of Plug-In Air Conditioners And Portable Heaters

Application No.: 12/778,052
Filing Date: May 11, 2010

Inventors	Appl. No.	Filing Date	Attorney Docket No.	Title
Steinberg	13/470,074 Published 2012/0221151	05/11/12	EFACT.011C1	System And Method For Using A Wireless Device As A Sensor For An Energy Management System
Steinberg et al.	13/409,729 Published 2012/0158350	03/01/12	EFACT.005C2	System And Method For Calculating The Thermal Mass Of A Building
Steinberg et al.	13/409,697 Published 2012/0221294	03/01/12	EFACT.004C2	System And Method For Using A Network Of Thermostats As Tool To Verify Peak Demand Reduction
Hublou et al.	13/523,697	06/14/12	EFACT.014A	System And Method For Optimizing Use Of Individual Hvac Units In Multi-Unit Chiller-Based Systems
Steinberg	13/725,447	12/21/12	EFACT.013C2	System And Method For Optimizing Use Of Plug-In Air Conditioners And Portable Heaters

Applicant notes that cited references, office actions, responses and notices of allowance currently exist or will exist for the above-referenced matters. Applicant also understands that the Examiner has access to sophisticated online Patent Office computing systems that provide ready access to the full file histories of these matters including, for example, specifications, drawings, pending claims, cited art, office actions, responses, declarations, and notices of allowance.

Rather than submit copies these file histories, Applicant respectfully requests that the Examiner continue to review these file histories online for past, current, and future information about these matters. Also, if the Examiner cannot readily access these file histories, the Applicant would be pleased to provide any portion of any of the file histories at any time upon specific Examiner request.

SUPPLEMENTAL INFORMATION DISCLOSURE STATEMENT

Submitted concurrently herewith is a Supplemental Information Disclosure Statement citing new references. Applicant notes that some of the references were previously submitted, but did not include dates. Thus, Applicant has resubmitted these references with a listing of associated dates. Applicant respectfully requests the

Application No.: 12/778,052
Filing Date: May 11, 2010

Examiner to consider the pending claims in connection with the submitted references in order to make the references of record.

NO DISCLAIMERS OR DISAVOWALS

Although the present communication may include alterations to the application or claims, or characterizations of claim scope or referenced art, the Applicants are not conceding in this application that previously pending claims are not patentable over the cited references. Rather, any alterations or characterizations are being made to facilitate expeditious prosecution of this application.

The Applicants reserve the right to pursue at a later date any previously pending or other broader or narrower claims that capture any subject matter supported by the present disclosure, including subject matter found to be specifically disclaimed herein or by any prior prosecution.

Accordingly, reviewers of this or any parent, child or related prosecution history shall not reasonably infer that the Applicants have made any disclaimers or disavowals of any subject matter supported by the present application.

CONCLUSION

Please charge any additional fees, including any fees for additional extension of time, or credit overpayment to Deposit Account No. 11-1410.

Respectfully submitted,

KNOBBE, MARTENS, OLSON & BEAR, LLP

Dated: 2-27-2013

By: John R. King
John R. King
Registration No. 34,362
Attorney of Record
Customer No. 20,995
(949) 760-0404

14874690:ad
022713

INFORMATION DISCLOSURE STATEMENT

Inventor : John Douglas Steinberg, et al.
App. No. : 12/778,052
Filed : May 11, 2010
For : SYSTEM, METHOD AND APPARATUS FOR IDENTIFYING
MANUAL INPUTS TO AND ADAPTIVE PROGRAMMING OF A
THERMOSTAT
Examiner : Unknown
Art Unit : 3744
Conf. No. : 5650

Mail Stop Amendment
Commissioner for Patents
P.O. Box 1450
Alexandria, VA 22313-1450

References and Listing

Submitted herewith in the above-identified application is an Information Disclosure Statement listing references for consideration. Copies of any listed foreign and non-patent literature references are being submitted.

Timing of Disclosure

This Information Disclosure Statement is being filed before the receipt of a first Office Action on the merits, and presumably no fee is required. If a first Office Action on the merits was mailed before the mailing date of this Statement, the Commissioner is authorized to charge the fee set forth in 37 CFR 1.17(p) to Deposit Account No. 11-1410.

Respectfully submitted,
KNOBBE, MARTENS, OLSON & BEAR, LLP

Dated: 2-27-2013

By: John R. King
John R. King
Registration No. 34,362
Attorney of Record
Customer No. 20,995
(949) 760-0404

INFORMATION DISCLOSURE STATEMENT BY APPLICANT	Application No.	12/778052
	Filing Date	05-11-2010
	First Named Inventor	Steinberg, John Douglas et al
	Art Unit	3744
<i>(Multiple sheets used when necessary)</i>	Examiner	Unknown
SHEET 1 OF 3	Attorney Docket No.	EFACT.007A

U.S. PATENT DOCUMENTS					
Examiner Initials	Cite No.	Document Number <i>Number - Kind Code (if known)</i> Example: 1,234,567 B1	Publication Date MM-DD-YYYY	Name of Patentee or Applicant	Pages, Columns, Lines Where Relevant Passages or Relevant Figures Appear
	1	4,136,732	01-1979	Demaray et al.	
	2	4,341,345	07-1982	Hammer et al.	
	3	4,475,685	10-1984	Grimado, et al.	
	4	4,655,279	04-1987	Harmon	
	5	5,244,146	09-1993	Jefferson et al.	
	6	5,270,952	12-1993	Adams et al.	
	7	5,314,004	05-1994	Strand et al.	
	8	5,462,225	10-1995	Massara et al.	
	9	5,544,036	08-1996	Brown et al.	
	10	5,555,927	09-1996	Shah	
	11	6,115,713	09-05-2000	Pascucci, et al.	
	12	6,260,765	07-2001	Natale et al.	
	13	7,356,384	04-2008	Gull, et al.	
	14	7,644,869	01-2010	Hoglund et al.	
	15	7,784,704	08-31-2010	Harter	
	16	7,848,900	12-07-2010	Steinberg, John Douglas et al.	
	17	7,894,943	02-22-2011	Sloup et al.	
	18	7,908,116	03-15-2011	Steinberg, John Douglas et al.	
	19	7,908,117	03-15-2011	Steinberg, John Douglas et al.	
	20	8,010,237	08-30-2011	Cheung, Leo et al.	
	21	8,019,567	09-13-2011	Steinberg, John Douglas et al.	
	22	8,090,477	01-03-2012	Steinberg, John Douglas	
	23	8,131,497	03-06-2012	Steinberg, John Douglas et al.	
	24	8,131,506	03-06-2012	Steinberg, John Douglas et al.	
	25	8,180,492	05-15-2012	Steinberg, John Douglas	
	26	8,340,826	12-25-2012	Steinberg, John Douglas	
	27	13/523,697	06-14-2012	Hublou, et al.	
	28	13/725,447	12-21-2012	Steinberg, John Douglas	
	29	2004/0176880	09-09-2004	Obradovich, et al.	

Examiner Signature	Date Considered
<p>*Examiner: Initial if reference considered, whether or not citation is in conformance with MPEP 609. Draw line through citation if not in conformance and not considered. Include copy of this form with next communication to applicant.</p>	

T¹ - Place a check mark in this area when an English language Translation is attached.

INFORMATION DISCLOSURE STATEMENT BY APPLICANT	Application No.	12/778052	
	Filing Date	05-11-2010	
	First Named Inventor	Steinberg, John Douglas et al	
	Art Unit	3744	
<i>(Multiple sheets used when necessary)</i>		Examiner	Unknown
SHEET 2 OF 3		Attorney Docket No.	EFACT.007A

U.S. PATENT DOCUMENTS					
Examiner Initials	Cite No.	Document Number Number - Kind Code (if known) Example: 1,234,567 B1	Publication Date MM-DD-YYYY	Name of Patentee or Applicant	Pages, Columns, Lines Where Relevant Passages or Relevant Figures Appear
	30	2006/0214014	09-28-2006	Bash, et al.	
	31	2007/0045431	03-03-2007	Chapman, et al.	
	32	2008/0198549	08-21-2008	Rasmussen, et al.	
	33	2009/0240381	09-2009	Lane	
	34	2009/0281667	11-2009	Masui, et al.	
	35	2010/0019052	01-2010	Yip	
	36	2010/0070086	03-2010	Harrod, et al.	
	37	2010/0070089	03-2010	Harrod, et al.	
	38	2010/0070093	03-2010	Harrod, et al.	
	39	2010/0211224	08-2010	Keeling, et al.	
	40	2010/0235004	09-2010	Thind	
	41	2010/0282857	11-11-2010	Steinberg	
	42	2010/0289643	11-2010	Trundle, et al.	
	43	2010/0308119	12-09-2010	Steinberg, et al.	
	44	2010/0318227	12-16-2010	Steinberg, et al.	
	45	2011/0031323	02-2011	Nold, et al.	
	46	2011/0290893	12-01-2011	Steinberg	
	47	2011/0307103	12-15-2011	Cheung, et al.	
	48	2012/0065935	03-15-2012	Steinberg, et al.	
	49	2012/0086562	04-12-2012	Steinberg	
	50	2012/0158350	06-21-2012	Steinberg, et al.	
	51	2012/0221151 A1	08-30-2012	Steinberg, John Douglas	
	52	2012/0221294 A1	08-30-2012	Steinberg, John Douglas et al.	

FOREIGN PATENT DOCUMENTS						
Examiner Initials	Cite No.	Foreign Patent Document Country Code-Number-Kind Code Example: JP 1234567 A1	Publication Date MM-DD-YYYY	Name of Patentee or Applicant	Pages, Columns, Lines Where Relevant Passages or Relevant Figures Appear	T ¹
	53	EP 0415747	03-06-1991	Shaw, et al.		
	54	KR 10-1994-0011902	06-22-1994	Koryo Digital Elect. Co.		

Examiner Signature	Date Considered
<p>*Examiner: Initial if reference considered, whether or not citation is in conformance with MPEP 609. Draw line through citation if not in conformance and not considered. Include copy of this form with next communication to applicant.</p>	

T¹ - Place a check mark in this area when an English language Translation is attached.

INFORMATION DISCLOSURE STATEMENT BY APPLICANT	Application No.	12/778052
	Filing Date	05-11-2010
	First Named Inventor	Steinberg, John Douglas et al
	Art Unit	3744
<i>(Multiple sheets used when necessary)</i>	Examiner	Unknown
SHEET 3 OF 3	Attorney Docket No.	EFACT.007A

FOREIGN PATENT DOCUMENTS						
Examiner Initials	Cite No.	Foreign Patent Document Country Code-Number-Kind Code Example: JP 1234567 A1	Publication Date MM-DD-YYYY	Name of Patentee or Applicant	Pages, Columns, Lines Where Relevant Passages or Relevant Figures Appear	T ¹
	55	KR 10-2000-0059532	10-05-2000	Dang Hae System Co.		

NON PATENT LITERATURE DOCUMENTS			
Examiner Initials	Cite No.	Include name of the author (in CAPITAL LETTERS), title of the article (when appropriate), title of the item (book, magazine, journal, serial, symposium, catalog, etc.), date, page(s), volume-issue number(s), publisher, city and/or country where published.	T ¹
	56	Bourhan, et al., "Dynamic model of an HVAC system for control analysis", Elsevier 2004	
	57	Emerson Climate Technologies, "Network Thermostat for E2 Building Controller Installation and Operation Manual", 2007	
	58	Johnson Controls, "T600HCx-3 Single-Stage Thermostats", 2006	
	59	Written Opinion and Search Report for PCT/US2011/032537, dated 12/12/11 (our reference EFACT.012WO)	
	60	Comverge SuperStat Flyer, prior to June 28, 2007	
	61	Control4 Wireless Thermostat Brochure, 2006	
	62	Cooper Power Systems Web Page, 2000-2009	
	63	Enernoc Web Page, 2004-2009	
	64	Enerwise Website, 1999-2009	
	65	Honeywell Programmable Thermostat Owner's Guide, www.honeywell.com/yourhome, 2004	
	66	PIER, Southern California Edison, Demand Responsive Control of Air Conditioning via Programmable Communicating; February 14, 2006	
	67	Proliphix Thermostat Brochure, prior to June 2007	

14876325:ad
022013

Examiner Signature	Date Considered
*Examiner: Initial if reference considered, whether or not citation is in conformance with MPEP 609. Draw line through citation if not in conformance and not considered. Include copy of this form with next communication to applicant.	

T¹ - Place a check mark in this area when an English language Translation is attached.

Electronic Acknowledgement Receipt

EFS ID:	15066632
Application Number:	12778052
International Application Number:	
Confirmation Number:	5650
Title of Invention:	SYSTEM, METHOD AND APPARATUS FOR IDENTIFYING MANUAL INPUTS TO AND ADAPTIVE PROGRAMMING OF A THERMOSTAT
First Named Inventor/Applicant Name:	John Douglas Steinberg
Customer Number:	20995
Filer:	John R. King/Daniela Lopez
Filer Authorized By:	John R. King
Attorney Docket Number:	EFACT.007A
Receipt Date:	27-FEB-2013
Filing Date:	11-MAY-2010
Time Stamp:	18:38:46
Application Type:	Utility under 35 USC 111(a)

Payment information:

Submitted with Payment	no
------------------------	----

File Listing:

Document Number	Document Description	File Name	File Size(Bytes)/ Message Digest	Multi Part /.zip	Pages (if appl.)
1	Foreign Reference	EFACT-007A_REF53.pdf	2026505 <small>9c345c6f4d38f249db2061e73daa7ab4003c44c8</small>	no	32

Warnings:

Information:

2	Foreign Reference	EFACT-007A_REF54.pdf	321753	no	6
			1960258c7656fda07d6de61a595a2b28ec8c826e		
Warnings:					
Information:					
3	Foreign Reference	EFACT-007A_REF55.pdf	54620	no	2
			9563c433927c9d59c047771d2c59c2b8b87f6972		
Warnings:					
Information:					
4	Non Patent Literature	EFACT-007A_REF56.pdf	677464	no	17
			22e809c8f5e11f8393a0734d92dfccea537e761		
Warnings:					
Information:					
5	Non Patent Literature	EFACT-007A_REF57.pdf	1039896	no	24
			50b5c67fa78731a87f2292081e9146973c354c55		
Warnings:					
Information:					
6	Non Patent Literature	EFACT-007A_REF59.pdf	265635	no	10
			b6fe4700354df6ae79e78a2679a7bf4ace9814d7		
Warnings:					
Information:					
7	Non Patent Literature	EFACT-007A_REF60.pdf	744668	no	2
			e82855305c53c89dca02e027b16bfe7619f7c7b1		
Warnings:					
Information:					
8	Non Patent Literature	EFACT-007A_REF61.pdf	323369	no	2
			9835013e9418b9b64e3dcf5943873484c344a615		
Warnings:					
Information:					
9	Non Patent Literature	EFACT-007A_REF62.pdf	1062927	no	12
			8d5b8b0fd45145235d296a24486f8d990595dbd8		
Warnings:					
Information:					
10	Non Patent Literature	EFACT-007A_REF63.pdf	586076	no	3
			523cf03560b08423ed32a99da307121a24be62c2		
Warnings:					
Information:					

11	Non Patent Literature	EFACT-007A_REF64.pdf	147770	no	2
			93a28e0ee7c0b3b584438f646d584f8f59a9fcd1		
Warnings:					
Information:					
12	Non Patent Literature	EFACT-007A_REF65.pdf	2405779	no	64
			981e0c1ea3284d441578bea33535c054e762836a		
Warnings:					
Information:					
13	Non Patent Literature	EFACT-007A_REF66.pdf	8669506	no	93
			fcb80c816f2e4596b3ba7f6d6eab944fa360e3a3		
Warnings:					
Information:					
14	Non Patent Literature	EFACT-007A_REF67.pdf	2343467	no	2
			7bef06c6b0e0d3648750cb906918814c3877d36b		
Warnings:					
Information:					
15	Non Patent Literature	EFACT-007A_REF58.pdf	920931	no	16
			389343f6701d90dedb5dd95956bdc70f5498ecb0		
Warnings:					
Information:					
16		EFACT-007A_prelimamend.pdf	411473	yes	9
			b331023f5d6fb081073da6ff20efb6302dd723f1		
	Multipart Description/PDF files in .zip description				
	Document Description		Start	End	
	Preliminary Amendment		1	1	
	Claims		2	5	
	Applicant Arguments/Remarks Made in an Amendment		6	9	
Warnings:					
Information:					
17		EFACT-007A_ids.pdf	235554	yes	4
			2987d53a8ee7c4df3a3f9c9bc458e6f93db19e9		
	Multipart Description/PDF files in .zip description				
	Document Description		Start	End	

	Transmittal Letter	1	1
	Information Disclosure Statement (IDS) Form (SB08)	2	4

Warnings:

Information:

Total Files Size (in bytes):

22237393

This Acknowledgement Receipt evidences receipt on the noted date by the USPTO of the indicated documents, characterized by the applicant, and including page counts, where applicable. It serves as evidence of receipt similar to a Post Card, as described in MPEP 503.

New Applications Under 35 U.S.C. 111

If a new application is being filed and the application includes the necessary components for a filing date (see 37 CFR 1.53(b)-(d) and MPEP 506), a Filing Receipt (37 CFR 1.54) will be issued in due course and the date shown on this Acknowledgement Receipt will establish the filing date of the application.

National Stage of an International Application under 35 U.S.C. 371

If a timely submission to enter the national stage of an international application is compliant with the conditions of 35 U.S.C. 371 and other applicable requirements a Form PCT/DO/EO/903 indicating acceptance of the application as a national stage submission under 35 U.S.C. 371 will be issued in addition to the Filing Receipt, in due course.

New International Application Filed with the USPTO as a Receiving Office

If a new international application is being filed and the international application includes the necessary components for an international filing date (see PCT Article 11 and MPEP 1810), a Notification of the International Application Number and of the International Filing Date (Form PCT/RO/105) will be issued in due course, subject to prescriptions concerning national security, and the date shown on this Acknowledgement Receipt will establish the international filing date of the application.



(12) **EUROPEAN PATENT APPLICATION**

(21) Application number: **90309473.8**

(51) Int. Cl.⁵: **F24F 11/00, F24F 3/044**

(22) Date of filing: **30.08.90**

(30) Priority: **30.08.89 AU 6035/89**

Applicant: **LUMINIS PTY. LIMITED**
 5th Floor Security House 233 North Terrace
 Adelaide South Australia 5000(AU)

(43) Date of publication of application:
06.03.91 Bulletin 91/10

(72) Inventor: **Shaw, Allan, Dr.**
 5th Floor, Security House 233 North Terrace
 Adelaide(AU)
 Inventor: **Luxton, Russell, Estcourt, Prof.**
 5th Floor, Security House 233 North Terrace
 Adelaide, South Australia(AU)

(84) Designated Contracting States:
AT CH DE ES FR GB GR IT LI NL

(71) Applicant: **Shaw, Allan, Dr.**
 5th Floor, Security House 233 North Terrace
 Adelaide South Australia(AU)

Applicant: **Luxton, Russell Estcourt, Prof.**
 5th Floor, Security House 233 North Terrace
 Adelaide South Australia(AU)

(74) Representative: **Whalley, Kevin et al**
M'CAW & CO. 41-51 Royal Exchange Cross
Street
Manchester M2 7BD(GB)

(54) **Comfort integration and energy efficient method of air conditioning.**

(57) An air conditioned space is cooled within a narrow target zone (as depicted on a psychrometric type chart) within which human occupants of the conditioned space would feel thermally comfortable, wherein factors including the heat transfer resistance of occupants' clothing and level of physical activity determine the target zone, by a method which includes correction of operative temperature, relative air velocity and humidity within the conditioned space 104, inherently controlling humidity by control of effective dehumidifier size 102 while maintaining a low face velocity of air and a high velocity of coolant flow, but varying either, or both, dehumidifier size 102 and the leaving air temperature if humidity ratio falls below four or exceeds thirteen grams of water per kilogram of dry air.

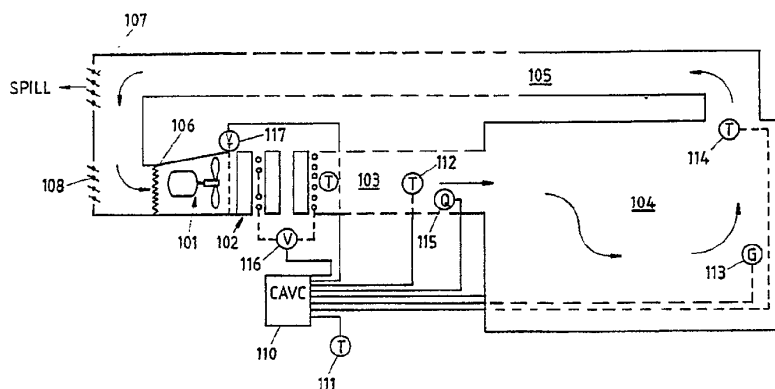

FIG 6a

METHOD AND MEANS OF AIR CONDITIONING

This invention relates to a method of air conditioning and a means of controlling an air conditioner in such manner as to achieve thermal conditions which closely approximate those recommended by the ASHRAE Standard on Thermal Environmental Conditions for Human Occupancy, or other similar standards based on the "comfort equation", over a broad range of operating conditions.

5

BACKGROUND OF THE INVENTION

The ASHRAE Standard 55-1981 entitled "Thermal Environment Conditions for Human Occupancy" sets out the following parameters which require design attention:

Operative Temperature (typical ranges for a building in which occupants are mostly sedentary depend on humidity but span approximately 3.5 °C within the global ranges, summer 22 °C -27 °C, winter 20 °C - 23 °C)

Humidity (4.2 - 12 g/kg moisture ratio)

15 Air movement (summer not exceeding 0.25 m/sec.),
(winter not exceeding 0.15 m/sec.)

Mean radiant temperature (operative temperature normally being an average of air temperature and mean radiant temperature)

Thermal resistance of clothing

20 Occupants' average metabolic rate (having regard to activity level).

A revision of this Standard, designated AINSI/ASHRAE Standard 55-81R has been released for public review and proposes tighter limits by specifying that the relative humidity should lie between 60% and 30% and narrowing the temperature range by approximately 0.5 °C.

This invention addresses all the above parameters, and, in addition, addresses the ventilation requirements which require a minimum air velocity through air distribution registers for proper diffusion of the supply air. It does not directly address other parameters listed in the Standard, such as non-steady and non-uniform temperature, radiant asymmetry and floor temperatures. It does, however, provide a means and method whereby operative temperature and the insulating effect of most people's clothing may be estimated, and whereby a conditioned space may be retained within that portion of the "comfort zone", illustrated for a specific example situation in the psychrometric chart on page 5 of the ASHRAE Standard, necessary to ensure also that the relative air velocity requirements, illustrated for example in Fig 17 of Chapter 8 of ASHRAE Fundamentals 1985, are satisfied at all times.

The ability to vary the volume of the conditioned air supply to offset the sensible load in individual zones often causes the Variable Air Volume (VAV) system to be preferred to the Constant Air Volume (CAV) system, in which variations in sensible load are accommodated by changing the conditioned supply air temperature but maintaining its volume flow. Both systems suffer from imperfections and these become manifest as the load sensed by the control system reduces, that is, as the sensible load reduces. In VAV systems often the volume of ventilation air delivered to the minimum load zone is insufficient to avoid stuffiness; lack of air motion accentuates the sense of discomfort and dissatisfaction felt by the occupants. Also the humidity of the air can rise to unacceptable levels at part load. The CAV system avoids the stuffy, stagnant air complaints but frequently results in even less acceptable levels of humidity.

The invention is applicable to both existing and new VAV or CAV systems.

Reference can be made to Australian patents 530554 and 597757, and U.S. Patent 4942740. These patents relate to some of a series of inventions for which patents have been granted or are pending and which trace the development of several methods of air conditioning which when combined become the method known as the low face velocity/high coolant velocity (LFV/HCV) method. This invention embodies features of said patents, and relates to a means and method whereby the thermal conditions for human comfort can be yet more closely achieved, which is the principal purpose of this particular invention. As indicated above the method may be used with both constant air volume (CAV) and variable air volume (VAV) systems and is compatible with all conventionally employed coolants. To a limited degree the present method can be made compatible with conventional systems which are unrelated to the earlier inventions by the proponents but is most readily effected in conjunction with the invention of said Patents 597757 and 4942740.

Physically based empirical equations have been developed to describe the thermal equilibrium between a human subject and the surroundings. The effects of each of the parameters discussed above on the rate

of heat loss from the human subject are combined in an equation known as "the comfort equation". This long equation and its physical and empirical bases are succinctly summarized by B.W. Olesen in an article entitled "Thermal Comfort", *Bruel & Kjaer Technical Review No. 2, 1982*, and in more detail in standard texts. The physically based "comfort equation" allows the quantitative estimation of the various heat gains and losses by the subject but does not indicate the reaction of the subject to those gains and losses. Thermal comfort is defined as "that condition of mind in which satisfaction is expressed with the thermal environment". By testing the reactions of many hundreds of subjects to defined conditions within fully instrumented environmental test chambers, Professor P.O. Fanger of the Technical University of Denmark determined the most probable reactions of subjects and correlated these with the various effects on heat gains and losses embodied in the "comfort equation". This he did in a manner which allows the most probable "predicted mean vote" (PMV) of persons to their thermal environment to be deduced through solution of the "comfort equation". Fanger's results are compatible with those of Professor A.P. Gagge and others in the United States of America and have been verified and extended by researchers in many other countries. These results have been drawn together to form the basis for the ASHRAE Standard 55-81 on thermal environmental conditions for human occupancy. This Standard is advisory. It indicates the thermal conditions for which designers should aim in order to ensure that the majority of occupants feel thermally comfortable, i.e. not too hot, not too cold, not too moist, not too dry.

It is important to note that human comfort involves factors other than thermal comfort. Lighting level and colour, noise level and spectrum, posture, odour, touch, disturbance by breeze and by other persons can, if unacceptable, cause discomfort so nullifying attempts to satisfy conditions for thermal comfort to which the present invention specifically relates.

Numerous tables and charts have been constructed from the "comfort equation". No one single table or chart is sufficient to cover fully the influence of all the above listed variables. Nevertheless the major factors influencing human comfort are revealed by an examination of several of these charts. The aforesaid article by B.W. Olesen indicates that to illustrate all aspects of the "comfort equation" requires twenty eight different charts or diagrams.

The comfort equation expresses the energy balance between a person and their surroundings assuming that steady state equilibrium has been established. Using the notation of ASHRAE Fundamentals Handbook (1989) the total rate of energy output by the person in a steady state situation is equal to the metabolic rate. Some of this energy may be expended in performing mechanical work such as lifting a weight, as when walking up stairs, but the remainder appears as heat which must be lost to the surroundings if the person's basal temperature is to remain constant without the body invoking the thermoregulatory reactions of heavy sweating if too hot or shivering (to increase metabolic rate) if too cold. Thus the net rate of heat loss from the person per unit of skin surface area is (M-W) Watts per square metre.

The mechanisms by which the heat is lost are by transfer through the skin, Q_{sk} , and by transfer through the lungs, that is by respiration, Q_{res} .

The loss from the skin can be subdivided into a loss of sensible heat by convection, C, and by radiation, R, and a loss of latent heat through evaporation of moisture from the skin, E_{sk} .

The loss by respiration is substantial. It can be divided into a convective loss C_{res} and an evaporative loss E_{res} .

All quantities are expressed in units of Watts per square metre of skin surface. When a "standard" body surface area, known as the "Dubois surface area", is specified the metabolic rate may, for ease of comparison, be expressed in the "met" unit where 1 met = 58.2 W/m² 50 Kcal/(h.m²) is the metabolic rate of a healthy adult person when seated quietly.

For a nude subject the surface area of skin can be determined and the skin temperature measured at representative points. Furthermore the heat transfer coefficients for convection and radiation, hence the sensible heat exchange with the surroundings, and the rate of evaporation of moisture from the skin can be determined. Similarly the sensible heat and the moisture losses from the lungs can be obtained from empirical equations deduced by Professor Fanger. Thus, all parameters of the comfort equation may be determined for the nude subject.

The effect of clothing is to add a layer of insulation to parts of the body. This insulation may be described as if it is a single equivalent uniform layer over the whole body. The insulating value is expressed in the units of "clo" where 1 clo = 0.155 m². °C/W. The clothing also changes the surface area through which heat and moisture are exchanged with the surroundings and hence a small correction must be made to the Dubois surface area. The clo values for a wide range of garments from underwear to fur top coats have been tabulated in various reference books and are summarised in the aforesaid ASHRAE Standard.

Taking all factors into account P.O. Fanger in his book "Thermal Comfort", published in the readily available edition in 1982 by Krieger Publishing Company, Florida, developed the single equation which is

EP 0 415 747 A2

the equation now most frequently referred to as "the comfort equation". The equation is written in the form given below. In the present invention ideally it is solved as an algorithm within the control system or, in the simplest realization, its solution is estimated from tabulated data for later combination with other data to set manually a zone thermostat.

5 The Fanger comfort equation is

$$(M-W) = 3.96 \times 10^{-8} f_{cl} [(t_{cl} + 273)^4 - (t_r + 273)^4]$$

$$- f_{cl} h_c (t_{cl} - t_a)$$

$$+ 3.05[5.73 - 0.007(M-W) - p_a]$$

$$+ 0.42[(M-W) - 58.15]$$

10 $+ 0.0173 M(5.87 - p_a)$

$$+ 0.0014 M(34 - t_a)$$

where $t_{cl} = 35.7 - 0.0275 (M-W)$

$$- k I_{cl} [(M-W)$$

$$- 3.05[5.73 - 0.007(M-W) - p_a]$$

15 $- 0.42[(M-W) - 58.15] - 0.0173 M(5.87 - p_a)$

$$- 0.0014 M(34 - t_a)]$$

and M = Metabolic energy production rate, W/m²

W = External work, W/m²

f_{cl} = Ratio of surface area of clothed body to that of nude body

20 t_{cl} = Temperature of surface of clothing, °C

t_r = mean radiant temperature received by subject, °C

h_c = convective heat transfer coefficient W/m²K

t_a = air temperature in conditioned space, °C

p_a = partial pressure of water vapour in air, kPa

25 $k = 0.155 \text{ m}^2 \cdot \text{°C}/(\text{clo} \cdot \text{W})$ = a unit conversion

I_{cl} = intrinsic clothing insulation.

The values of h_c and f_{cl} are given by

2.38 $(t_{cl} - t_a)^{0.25}$ for $2.38 (t_{cl} - t_a)^{0.25} > 12.1 \sqrt{V}$

30 $h_c =$

12.1 V for $2.38 (t_{cl} - t_a)^{0.25} < 12.1 \sqrt{V}$

$f_{cl} =$

$1.00 + 0.2 I_{cl}$ for $I_{cl} < 0.5 \text{ clo}$

$1.05 + 0.1 I_{cl}$ for $I_{cl} > 0.5 \text{ clo}$

35 where V = relative velocity of air, m/s.

The difference between the left hand and right hand sides of the comfort equation is the thermal load on the body. The thermal load L is defined in ASHRAE 1989 Fundamentals Handbook as the difference between the internal heat production and the heat loss to the actual environment for a person hypothetically kept at comfortable skin temperatures and thermoregulatory sweat secretion rate for the actual activity level.

40 Fanger devised a voting scale for comfort and means of determining the predicted mean vote (PMV) of a large group of subjects for a given environment. The scale is

+3 hot

+2 warm

+1 slightly warm

45 0 neutral

-1 slightly cool

-2 cool

-3 cold

50 The predicted mean vote was found to be fitted closely by the equation

$$PMV = [0.303 \exp(-0.036 M) + 0.028]L$$

where the thermal load L is determined from the comfort equation as indicated above.

The percentage of people dissatisfied with a given thermal environment may be related to the predicted mean vote and it has been found that not more than 10 percent of occupants will be dissatisfied, that is 90 percent will be satisfied, if

55 $-0.5 \leq PMV \leq + 0.5.$

These limits define the range of conditions within which the thermal environment is controlled according to the present invention. It may be noted that even for a predicted mean vote of zero, five percent of the

occupants are likely to be dissatisfied.

It must be stressed that this is one only of the criteria available for determining acceptable thermal environmental conditions. We seek here to establish the method of achievement of human thermal comfort rather than the specific criteria used to measure that thermal comfort.

5 While most designers are successful in satisfying the thermal comfort criteria at peak load conditions, few if any have been able also to satisfy the criteria at all operating loads without resorting to the mostly practice of overcooling and then reheating the air. This lack of success has caused many designers to ignore the recommendations of the aforesaid Standard. This in turn has contributed to the development of the "sick building syndrome". The problem stems from a fundamental incompatibility between the
10 recommendations of the Standard and the means by which conventional air conditioning systems are controlled.

It is the aim of this invention to remove this incompatibility to allow the requirements for the thermal comfort of occupants to be satisfied at all conditions of operation of the air conditioning system. To do this the broad comfort zone depicted on the aforesaid ASHRAE psychrometric chart must be subdivided into a
15 series of narrower bands each providing the "target" for operation over its own range of operating load conditions and occupant related characteristics.

The narrow "target zones" must embrace the wide range of clothing worn by occupants of an air conditioned space during the operating year, the diverse ranges of activity by the occupants varying from sedentary (met = 1) to very active (met = 3), and the need to consider relative air velocity (velocity of air over
20 occupants of a conditioned space), air dry bulb temperature, radiant temperature and operative temperature, volume flow rate of air, sensible and total heat load, and humidity ratio. If these matters are considered, the level of human comfort now deemed desirable can be achieved only by adjusting from one narrow target zone to another such that effectively a narrow "moving comfort target zone" is defined within the relatively broad ASHRAE Standard comfort zone. This moving target zone will occupy different positions on a
25 psychrometric, or psychrometric type, chart as both occupant related and system related conditions change during the operating year.

However, the Applicants herein have ascertained that under most climatic conditions the LFV/HCV air conditioning system, the subject of aforesaid U.S. Patent 4942740, can inherently restrain humidity in the occupied space from rising above the limit recommended by the aforesaid Standard. Control of relative air
30 velocity, supply air dry bulb temperature and dehumidifier size can, in this invention, achieve a design condition within the required very narrow target zone within the general comfort zone. The location of the target zone itself may be "moved" on a psychrometric chart, manually or automatically (or a combination of both), by changing control set points to accommodate changes in occupant clothing or activity, changes in the level of direct solar or other thermal radiation and changes in ambient conditions. Provided the building
35 design avoids excessive direct solar input through windows, diurnal adjustment is rarely required.

BRIEF SUMMARY OF THE INVENTION

40 In this invention, an air conditioned space is cooled within a narrow comfort target zone (as depicted on a psychrometric type chart), wherein factors including the heat transfer resistance of occupants' clothing and level of physical activity determine the target zone, by a method which includes mutual and sympathetic correction of operative temperature, relative air velocity and humidity within the conditioned space, inherently controlling humidity by control of effective dehumidifier size while maintaining a low face
45 velocity of air and a high velocity of coolant flow, but increasing either, or both, dehumidifier size and surface temperature if humidity ratio falls below four point two grams of water per kilogram of dry air.

Desirably, an electronic controller is employed which either directly or indirectly indicates to the means controlling the flow of supply air and to an Air Handling Unit controller the change in the requirements for the target zone so they may adjust appropriately. The difference between the ambient air enthalpy and that
50 in the conditioned space may also be sensed conventionally where economy cycle operation is required.

The preset parameters include adjustment for clothing and occupant activity, and in some instances for air flow velocity. Obviously there is considerable advantage in using the proponent's aforesaid invention the subject of said patents, especially in association with variable air volume since the increased dehumidification available at peak load due to reduction of the air flow velocity through the dehumidifier coil of
55 the Air Handling Unit greatly widens the range of simultaneous loads in different zones which can be accommodated; but as set out hereunder, a CAV system can also utilise this invention with considerable advantage if differences between the requirements of different rooms are not large, and/or if the CAV system allows stepwise changes of air flow volume.

BRIEF SUMMARY OF THE DRAWINGS

An embodiment of the invention is described hereunder in some detail with reference to the accompanying drawings, in which:

- 5 Fig. 1 is a psychrometric chart on which is shown the comparative performances of a conventional VAV system and the integrated system of this invention,
 Fig. 2 is a psychrometric type chart which illustrates the effect of light clothing (0.5 clo) and intermediate clothing (1.0 clo) on the location of a target zone for sedentary occupation, and also the effect of high activity level, on the sensation of operative temperature by a human subject for a range of relative air
 10 velocities between less than or equal to 0.1 metres per second and up to 1.5 metres per second.
 Fig. 3, extends the ASHRAE Standard 55 (1981) chart of the limits within which, statistically, 80 per cent of persons involved in mainly sedentary activity are likely to feel thermally comfortable, by superimposing for a range of combinations of clothing insulation and operative temperature, the diversity of clothing typical during the different seasons of the year, and the corresponding ranges of operative
 15 temperature within which the conditioned space must be maintained to satisfy the 80 percent acceptability limits. (A draft ASHRAE Standard indicates that the acceptability limits shown in Fig. 3 apply to 90 per cent of occupants).
 Fig. 4 is a portion of a psychrometric chart which shows schematically movement of relative velocity lines with operative temperatures between peak and minimum load conditions as the typical clothing of
 20 occupants varies during the cooling year. Also shown are the broad standard comfort zone and the revision of the upper and lower limits for humidity proposed by ASHRAE,
 Figs. 5A and 5B indicate the influence of relative velocity without and with the present comfort integration of this invention. The operative temperature scales on the abscissae have been aligned for clarity,
 Figs. 6A and 6B are diagrammatic representations of air conditioning installations which embody this
 25 invention, Fig. 6A representing a constant air volume system servicing a single zone, and Fig. 6B representing a multizone variable air volume system,
 Fig. 7 is a diagrammatic representation of a dehumidifier, illustrating seven coil configurations which progressively reduce the effective size of the dehumidifier, to provide a series of steps so to retain high coolant velocity as heat load reduces,
 30 Fig. 8 is a logic chart for a local controller incorporating the technology of this specification in a VAV system, and
 Fig. 9 is a logic chart for a local controller incorporating the technology in a CAV system.

35 BRIEF DESCRIPTION OF THE PREFERRED EMBODIMENT

Fig. 1 (full lines) is a psychrometric representation of this invention compared with that for a conventional VAV system (dashed lines).

- 40 As described in the specification of the LFV-HCV U.S. patent 49112740, the equilibrium room condition of a conventional VAV system, 3', is at a higher room humidity ratio than that for the LFV-HCV room condition, 3. As indicated in this example the equilibrium condition for the conventional system may rise to a moisture level which lies outside and above the area of acceptable comfort.

- 45 Although the LFV-HCV room condition, point 3, lies within the area of acceptable comfort, more critical examination indicates that conditions in the room may not necessarily be comfortable. The prime criterion of ASHRAE Standard 55-1981 is that at least 80 per cent of the occupants will feel thermally comfortable. As indicated in the previous section many factors influence this judgement or "condition of mind". It is a misconception to assume that the "comfort zone" indicated in that Standard is a sufficient requirement. Even that comfort area is only a graphical example in which the mean radiant temperature is assumed to be equal to the air dry bulb temperature. There is in fact a much smaller zone than that indicated in Fig. 1
 50 which defines conditions which are both necessary and sufficient to satisfy the prime criterion of thermal comfort. This zone is determined by the other variables indicated earlier.

- The most accurate means presently available to determine optimum human comfort conditions is by use of the empirical equations from which most of the published charts are derived. This is the preferred method, though this invention does not depend on the specific method used provided it satisfies the
 55 acceptability criteria for human comfort. Charts of restricted applicability which have been constructed from these equations will be employed in order to simplify the description of the invention.

Fig. 2 indicates the importance of relative air motion and level of activity. Three bands each traversed by four curves are presented. The first band and set of four curves on the right hand side (full lines)

represent thermal comfort conditions for clothing values 0.5 clo respectively for relative air velocities of 1.5 m/s, 0.5 m/s, 0.2 m/s and less than or equal to 0.10 m/s, and mainly sedentary activity typical of that in an office building for which the metabolic rate is 1 met. The second band and set of four curves (dashed lines) represent comfort conditions, also for medium clothing (1.0 clo) when sedentary (1 met), while the left hand band and set of chain dashed lines represent comfort conditions for high activity (3 met) and light clothing (0.5 clo). The "target zone" within the right hand band is for temperatures about 26 °C., clothing 0.5 clo, relative velocity between ≤ 0.1 m/s and 0.25 m/s and relative humidity between 30% and 60%. At relative velocities above 0.25 m/s, although occupants may feel thermally comfortable, they find the direct effects of the relative velocity disturbing.

The curves indicate the large influences of activity and attire on the required operative temperature. For example, on a marginal day for a given relative velocity, equal satisfaction is felt by sedentary subjects wearing medium clothing (1.0 clo) in an operative temperature of 24 °C and by lightly attired (0.5 clo) subjects performing high activity in an operative temperature of 14 °C. Similarly on a hot summer day (right hand and left hand sets of curves which assume that occupants are attired in light clothing) 26 °C, 19 °C and 14 °C are all equally comfortable operative temperature conditions for sedentary (26 °C) and for high activity respectively, where the 19 °C relates to a very high air velocity (1.5 m/s) and 14 °C relates to air velocity ≤ 0.1 m/s. (The 1.5 m/s figure greatly exceeds ASHRAE recommendations but is shown to illustrate the effect of velocity).

On all the charts air velocity variations narrow the available area of optimum comfort. The authoritative ASHRAE Standard ASHRAE 55-1981 specifies:

"Summer: the average air movement in the occupied zone shall not exceed 0.25 m/s."

"Winter: the average air movement in the occupied zone shall not exceed 0.15 m/s."

Note that the maximum time-average air movement allowed in the occupied zone is lower in winter than in summer. It is also indicated in the ASHRAE Standard that if temperature and humidity are acceptable there is no minimum air movement that is necessary for thermal comfort.

In normal air conditioning practice it is unlikely that zone temperatures higher than 26 °C in the summer would be considered comfortable. However comfort within the Standard allows the temperature to increase to 28 °C if accompanied by an increase in air movement of 0.275 m/s for each degree C increase in zone temperature. In this instance the increase in air movement increases the rate of heat transfer from occupants to compensate for the higher temperature air in the room so maintaining comfortable skin temperatures and skin wettedness.

To put into perspective the maximum relative velocities for winter and for summer the ASHRAE 55-1981 Standard states,

"Loose paper, hair and other light objects may start to be blown about at air movements of 0.8 m/s (160 fpm)."

The above considerations underline the importance in air conditioning system design of ensuring that supply air and diffusers are so placed and designed to deliver air to the room in such manner that the relative velocities in the vicinity of the occupants lie within the range specified by the ASHRAE 55-1981 Design Standard, or its equivalent. This invention assumes this is achieved by using best practice design methods in designing the air distribution system for peak load operation and that the relative velocity at any given point in the room is proportional to the volume flow rate of air to the room. By reducing the range of volume flow rate variation between peak and minimum part load, the invention itself contributes to the satisfaction of this assumption.

Most of the data reported in the literature on comfort conditions relate to low air movements. For example Table 1 of Standard 55-1981 reports "operative temperature range for 80% thermal acceptability is based on an air movement of 0.15 m/s". Fig. 1 of the Standard, in which clothing insulation is plotted as a function of operative temperature for sedentary activity at 50% relative humidity, is also based on a relative velocity of ≤ 0.15 m/s.

To evaluate the extent to which existing air conditioning systems adhere to human comfort principles, the design performance of an actual variable air volume (VAV) system designed for a high-rise office building in a temperate climate on the western seaboard of Australia is considered. Many types of air conditioning systems could be employed. The superior performance of the LFV-HCV system in maintaining sensible temperatures and humidity ratios which are always within the area of comfort shown in Fig. 1 has already been established, and proven in practice. The performance of this already superior low energy multizone LFV-HCV system is now contrasted with a system which incorporates the comfort integration of the present invention into the design.

Before proceeding with the comparison, a brief outline of the LFV-HCV-VAV multizone system is presented.

The following aspects of the conventional VAV system are retained in the LFV-HCV method:

A constant supply air temperature is maintained, the coolant flow rate is controlled to maintain the constancy of the supply air temperature, each zone has a thermostat which controls the damper settings to maintain the zone dry bulb temperature, the fan volume flow rate is regulated by one of a number of conventional methods to be compatible with the combined effect of the damper settings in the various zones.

However the LFV-HCV method is different from the conventional VAV system in that:
 the system operates at a substantially lower face velocity,
 the coolant velocity is higher, particularly at part load conditions during which the active size of the dehumidifier is reduced,
 the fin density, circuiting and coolant temperature are important design factors in optimization of performance over the full operating range,
 the system has a greater capacity to accommodate simultaneous multizone range variation, and
 the system uses less energy.

The following is the method which would be used in an LFV-HCV system using VAV and in accordance with our aforesaid patents for an installation suitable for the example office:

A coil is selected to satisfy the design requirements of an air handling unit to supply a number of zones on a typical level of a high-rise office building located in a temperate climate. A room summer dry bulb temperature of 24 °C is considered good design when coupled with a system which maintains humidity safely within the comfort areas shown in Fig. 4 (see for example Fig. 1). In Fig. 4, the standard broad comfort zone is shown in dashed lines and is cross-hatched. Apart from this and following best practice in the design of the air distribution system, no special regard is given to human comfort principles.

At peak load the selection provides a room condition of 24 °C and 48 per cent relative humidity, and offsets the room sensible heat ratio of 0.87 for the local climatic design condition.

At 65 per cent of the room sensible load the selection provides a room condition of 24 °C and 57 per cent relative humidity and offsets the room sensible heat ratio of 0.67 for a mild but humid part-load design condition, hereinafter called the humid part-load design condition.

During peak load conditions the building occupants will mostly be wearing light clothing. Thus the chart of Fig. 5A is the appropriate figure on which to indicate by an open circle the performance of the LFV-HCV system for peak conditions, without comfort integration. During humid part-load conditions, which occur most frequently during the Autumn, typical clothing will be a little heavier and the chart of Fig. 5B is applicable. The part load condition without comfort integration is again indicated by an open circle.

First, with reference to the peak load performance, at 24 °C, 48% RH, the room condition lies significantly below the relative velocity for comfort marked "less than 0.1 m/s". Thus, for 80% of occupants to be comfortable the air flow velocity must be less than 0.1 m/s. The fact that it appears that it must be significantly less than 0.1 m/s is not important as there is no minimum air movement specified as being necessary for thermal comfort if the operative temperature and humidity are satisfactory. Thus, if the air distribution system can achieve this low velocity, the performance is within the "acceptable" range.

The room condition achieved falls safely within the comfort zone of Fig. 4. However it is unlikely to be possible both to offset the peak load and to satisfy ventilation requirements without higher air velocities. The designer may be tempted to increase the supply air temperature and increase air volume at the expense of a higher fan cost. However this would aggravate the problem of increasing humidity in the conditioned space during humid part load operation. Thus this option should be rejected. Unless the ceiling is many metres above the floor it would be difficult to introduce the required volume flow of air while maintaining the low relative velocity demanded of the peak load design. Furthermore, during part load operation this air movement would be further decreased in a VAV system. Thus 24 °C is not a practical room dry bulb temperature for peak load operation. Even though it would at first sight appear that the human comfort conditions, as represented by the "comfort zone" depicted in Fig. 3, could be met, in practical terms the thermal loads and statutory ventilation requirements would be difficult to meet while also satisfying the low levels of air movement required for comfort at peak load and would lead to stagnant conditions at part load. The required minimum standard of ventilation is 7.5 litres per second per person.

Reference is now made to the room condition of 24 °C, 57% RH achieved during humid part-load operation: This is made thermodynamically compatible with the peak selection by reducing the active area of the dehumidifier coil and increasing the coolant flow velocity through the remaining active portions, according to the LFV/HCV invention, to offset both sensible and latent loads at the lower room sensible heat ratio of 0.67, a commonly occurring ratio for part-load conditions. But the relative velocity required for comfort at the design room condition (Figs. 5A and 5B) is greater than 0.4 m/s which is well above the maximum relative velocity recommended in the ASHRAE Standard. It is also incompatible with the peak

load condition in that less air is supplied to the room but air motion is required to be many times greater. Thus at part-load the system, though it properly offsets the sensible and latent heat loads in their correct ratio while maintaining a comfortable humidity ratio in the room, fails to maintain an acceptable relative velocity. Had the system been a conventional VAV system, without the LFV-HCV improvements, the relative velocity required for comfort would be even greater to compensate for the higher humidity indicated by room condition 3' in Fig. 1.

The air distribution system is identical for both peak and humid part load operation, the latter of which requires only 65 percent of the air flow volume required by the former. Thus it would be impossible to provide the performances indicated on Fig. 5A as being required for comfort at both peak and humid, or indeed any other part load conditions. The air required to offset part loads could not possibly be delivered through the same supply air system in a way which results in a higher relative velocity than that at peak load.

Although the above example is a particular application, the result is typical of present best-practice. As can be seen, either directly or indirectly, this best-practice is incompatible with the ASHRAE 55-1981 Standard for Thermal Environmental Conditions for Human Occupancy, with the principles of human comfort presented in Chapter 8 of ASHRAE 1985 Fundamentals, and with the work of P.O. Fanger of the Laboratory of Heating and Air Conditioning at the Technical University of Denmark, inter alia.

An examination of the charts of Figs. 5A and 5B clearly indicates that the operative temperature in the air conditioned space should not be constrained to a constant value, but should be allowed to vary as a function of the particular room loads of the moment and the clothing appropriate to the season. In the above example in which the room temperature of 24 °C was prescribed, it becomes clear that at peak loads this dry bulb temperature is too low and at part loads is too high for comfort to be achieved in a practical design.

The above analysis indicates that there is no logical means by which one could satisfy comfort standards while maintaining a fixed room dry bulb temperature in all the zones. In the cited example it was found to be impossible to maintain a relative velocity which satisfied the ASHRAE Comfort Standard. This conclusion must be qualified as it depends on the level of confidence in the Fig. 5 charts. To prepare these charts the dimensionality of the problem has been reduced by assuming that the air temperature equals the mean radiant temperature. The ASHRAE "area of comfort" (Fig. 4), on the other hand, is in terms of the "operative temperature". The "operative temperature" is defined in Paragraph 3.9 of ASHRAE Standard 55-1981 for the thermal environmental range for human comfort as "approximately the simple average of the air and mean radiant temperatures". Naturally, if the air temperature does equal the mean radiant temperature, as in an interior zone with low temperature lighting, this definition would be satisfied. Since often they will not be equal, the conclusions drawn from the use of Figs. 5A and 5B can only be regarded as qualitative. More detailed analysis based on the use of the full "comfort equation", from which the simplifications embodied in Figs. 4 and 5 are also distilled, show that these qualitative conclusions are nevertheless indicative of practical situations in which the mean radiant temperature differs from the dry bulb temperature, as would be found in most perimeter zones.

The chart values used in Fig. 4, even with the use of "operative temperature" as abscissa, deviate from the actual values derived from the full comfort equation when the insulation value of the clothing in the area designated "summer" differs from 0.5 clo. A correction factor of - 0.6 °C per 0.1 clo is recommended in ASHRAE 55-1981. Thus for the marginal 65% part load condition of 24 °C used in the example design, the operative temperature for a change from 0.5 clo to 0.9 clo would, under the conditions of Fig. 4 and Fig. 5 (where it is assumed that air temperature is equal to mean radiant temperature) require a shift of the comfort areas to the left by 2.4 °C.

Clearly this points to a preference in the application of this invention for a control system which senses the true values and then employs the basic equations rather than using chart values. In this manner both seasonal and diurnal variations in the various rooms or zones can be accommodated.

Adherence to human comfort principles will thus be seen to require changes in design of air conditioning systems and equipment. The necessary changes in method, design methodology and equipment selection are addressed by the present invention.

By way of contrast, the following sets forth requirements for this invention:

In the analysis above it has been indicated that human comfort principles are not adequately addressed by existing air conditioning systems. These systems have not been designed to satisfy human comfort though many designers may have been under the misconception that, by maintaining room conditions within the bounds of the area marked on Fig. 4, comfort would be assured. These findings may go a long way to explaining the occupant dissatisfaction which has been the subject of both technical papers and Open Forum debates within the learned societies.

It is the purpose of this invention to present a new method of air conditioning in which human comfort and proper air treatment may be integrated; that is, to present a method and system within which the air treatment is achieved by means which are compatible with all other requirements for thermal comfort at all times. The presentation of this method will continue to use as a vehicle the LFV-HCV-VAV system of U.S. patent 49112740. However as indicated above the method of this invention can also be extended, with modification, to the design of other types of air conditioning systems.

To demonstrate the invention and its numerous benefits, the performance of the LFV-HCV-VAV design with comfort integration will be determined for the same thermal design specifications as for the already superior system analysed above. It will enable a fair comparison of the new system and existing best-practice, and will support the assertion that, in this invention, human comfort principles can be integrated into the air conditioning system performance. Fig. 1 of ASHRAE Standards 55-1981 "Thermal Environmental Conditions for Human Occupancy" which provides the basis for Fig 3 indicates the operative temperature range within which 80% of occupants feel comfortable, if the humidity and air movement are also within acceptable limits. For summer conditions assuming clothing insulation is approximately 0.5 clo, the range is 22.8 °C to 26.1 °C. For humid part load conditions occurring in the Autumn when clothing insulation may be approximately 1.0 clo, the range is 19.5 °C to 23.2 °C. Thus the room operative temperature is set for peak load conditions to be 26 °C and that for humid part load conditions to be 23 °C, both of which temperatures are within the respective 80% acceptability ranges. These ranges are not mandatory but are selected to allow ready comparison with ASHRAE Standard 55-1981. It should be noted that they can be refined as indicated below.

In Fig. 3 the temperature ranges have been modified to allow for the typically lighter clothing generally worn in Australia, and to accommodate a mix of clothing weights being worn by occupants. This narrows the range of acceptable operative temperatures as indicated by the ranges designated by 'A', 'B' and 'C', in Fig. 3:

SUMMER RANGE 'A' is the operative temperature range for 80% acceptability assuming no jackets shed or donned.

MARGINAL RANGE 'B' is the similarly restricted comfort range during spring and autumn.

WINTER RANGE 'C' is the similarly restricted comfort range for heating.

These ranges expand in each direction by 0.6 °C for each 0.1 clo donned (at the lower limit) or removed (at the upper limit). A light jacket adds 0.22 clo and a bolero 0.15 clo.

The following sets forth a design for an LFV-HCV-VAV system for human comfort:

In Fig. 4 is indicated the area of the ASHRAE Standard 55-1981 charts within which are satisfied the presently acknowledged human comfort conditions for peak (right hand area, 0.5 clo) and for humid part-load (left hand area, 1.0 clo) conditions for the design considered herein. A four sided area is marked in with the left side representing the boundary designating a relative velocity of <0.1 m/s and the right side a relative velocity of 0.25 m/s to define the range of acceptable relative velocities. To lie within the ASHRAE limits, the top border of the area would be represented by a dew point temperature of 16.6 °C and the bottom border by a dew point temperature of 2.7 °C. However in anticipation of a revision of the standard the upper and lower bounds of the ranges indicated in Fig. 4 follow the 60% and 30% Relative Humidity lines respectively. Fig. 4 indicates the mutually compatible area for each operating condition by close cross hatching. To adhere to the ASHRAE Standard and to the thermal conditions found to be appropriate for human comfort the designer is constrained to operate within the very much smaller areas defined by the close cross hatching in selecting the room operative temperature. In this case Fig. 4 indicates the peak load and the humid part load performance conditions achieved by allowing flexibility of the room operative temperature. Both conditions then fall within the range in which 80% of the occupants will feel that the conditions are comfortable. Not shown is the continuum of target zones within which conditions between peak and minimum load, indicated by the continuous line, must fall to satisfy thermal comfort over the full range of operation of the air conditioning system.

The left hand column of Table 1 appended to this specification indicates the probable performance of the system with a room thermostat which varies its setting progressively as the sensible load changes from its peak value. The system performances at sensible loads which are 65 per cent and 50 per cent of the peak value are shown.

Figs. 5A and 5B reveal a LFV-HCV-VAV system which is completely compatible with the air conditioning design loads and with human thermal comfort requirements over the full range from peak to the 65 per cent part load condition. Should the system move to a 50 per cent part load condition the chart relative velocity lines would also move slightly to the left to accommodate the heavier clothing which is likely to be worn. The room operative air temperature on the chart would change only from 23 °C at 65 per cent part load to 22.8 °C at a part load which is 50 per cent of the peak sensible load.

Throughout the operating range the required relative velocity for optimum comfort would vary from 0.14 m/s at peak load conditions to 0.12 m/s at 65 per cent part load and to 0.09 m/s at 50 per cent part load. If the relative velocity in the room varies proportionally with the variation in volume flow of air supplied to the room and the room and supply air temperature is kept constant, the relative velocity at the 65 per cent condition would be 0.09 m/s and at 50 per cent, 0.07 m/s. If an increase in humidity is possible without exceeding the comfort level the small discrepancy between the relative velocity optimally desired and to relative velocity achieved could be eliminated by a small increase in the supply air temperature. This contrasts with the incompatibilities found in the earlier example design to the identical specification wherein it was found that a higher relative velocity was required for comfort at part load than that at peak load, an impossible situation.

The left hand column of Table 1 reveals the superior performance of this method in offsetting the thermal loads, meeting the ventilation loads, and achieving compatibility of the air supply requirements and the relative velocities required for comfort, thus simultaneously optimising performance and the known human comfort principles.

The above discussion and example may be summarised as follows:

Operating conditions which fall within the comfort area defined by ASHRAE Standard 55-81 may be necessary for creating "that condition of mind in which satisfaction is expressed with the thermal environment", but in most cases they will not be sufficient at all operating load conditions. At each operating load the constraints imposed by the relative velocity limits specified by ASHRAE Standard 55-1981 must also be satisfied. The relative velocity limits restrict acceptable conditions to a narrow band within the general comfort area and, in the example above, it was shown that this narrow band traverses from right to left in response to the changes from peak to minimum load conditions of the air conditioning system. It is this movement which is accommodated by the present invention. The aim is the simultaneous energy efficient integration of load, ventilation and human comfort requirements into the design of air conditioning systems.

Reference is now made to the system illustrated in Figs. 6A, 6B and 7.

In Fig. 6A, a Constant Air volume air conditioner comprises a fan 101 which propels air through a dehumidifier 102, a duct 103, and through a conditioned space 104. The air is returned to the fan 101 through duct 105 and filters 106. Some return air is spilled through one or more controlled or uncontrolled vents 107 and this is replaced with fresh air drawn from outside via a controlled or uncontrolled damper 108. Coolant is supplied to the dehumidifier from a chiller plant (not shown).

An electronic controller 110 receives the following intelligence from sensors
 ambient air temperature.....thermometer 111
 supply air temperature (optional).....thermometer 112
 conditioned space operative temperature directly or via.....globe thermometer 113
 conditioned space humidity (optional).....humidity sensor 126
 return air temperature.....thermometer 114
 supply air volume flow rate (optional)via pressure or velocity sensor 115.

The controller controls coolant valves collectively designated 116 and throttle valve 117, as well as spill and ventilation air dampers 107 and 108 if same are active. In a CAV system, flow control dampers in the supply air duct are not used but the fan motor may have the facility of being switched between two or more speeds under the command of the controller 110.

In Fig. 6B, a Variable Air Volume air conditioner comprises a fan 101 which draws air through a dehumidifier 102 and passes it via a duct 103 and dampers 109 to a conditioned space 104 from which it is returned to the dehumidifier 102 through a duct 105 and filters 106. As with the CAV system of Fig. 6A some return air is spilled through one or more controlled or uncontrolled vents 107 and is replaced with fresh air drawn from outside via a controlled or uncontrolled damper 108. Optionally there may be a spill fan 131 and/or a return air fan 132 and/or return air dampers 133 also in the return air path. Also a supply air damper 125 may be used to effect change in the volume of air delivered by the fan. Preferably such change would be effected by variation of the speed of the fan motor by means of variable speed drive 134.

The control function is shown in Fig. 6B to be divided between a local zone VAV controller 120 and the Air Handling Unit (AHU) controller 110. The two controllers can be combined into a single unit but for clarity here and for larger systems involving several zones it is convenient to locate the zone controllers 120, 220, 320, etc. within the several zones and use a Local Area Network (LAN) 140 or similar communication means to send and receive information to and from the Air Handling Unit controller.

The zone VAV controller 120 receives the following intelligence from sensors:
 supply air temperature at zone.....thermometer 112
 conditioned space operative temperature...directly or via.....globe thermometer 113

zone and return air temperature.....thermometer 114
 supply air volume flow rate.....via pressure or velocity sensor 115
 zone supply damper setting.....angle 109.
 humidity (optional) RH or DP.....126

5 In addition the zone VAV controller 120 receives both sensed and processed intelligence from the AHU controller 110, for example information about ambient conditions.

Zone controller 120 has various manual inputs 119, some of which are set during commissioning of the system, some of which may be set seasonally, and in simple systems some of which may be input at intervals throughout a day. These manual inputs are delineated below in the discussion of the control
 10 function. Manual inputs common to all zones are best input directly to the AHU controller, as indicated by 121, and then communicated to all zones via the LAN 140 if a distributed control system, as illustrated, is employed.

At its simplest level the zone VAV controller could be a conventional thermostat which could be reset manually by the occupants of the zone with the aid of a look-up table of 40 settings for different times of
 15 year, levels of activity, sun angle and daily weather forecast. In more sophisticated applications the above parameters are either sensed directly or determined by calculation or from information stored in the memory banks of the controllers 110 and 120.

The AHU controller receives the following intelligence from sensors:

ambient air temperature.....temperature 111
 20 supply air temperature leaving AHU.....temperature 122
 mixture temperature entering AHU.....temperature 123
 enthalpy difference between return air and ambient.....enthalpy difference 124
 fan motor speed.....tachometer 134
 supply air damper setting (if fitted).....angle 125
 25 coolant throttle valve setting.....angle or travel 117
 dehumidifier change-over valve.....status 116
 spill fan (if fitted).....status 131
 return air fan (if fitted).....status 132
 return air damper setting (if fitted).....angle 133
 30 spill air damper setting (if active).....angle 107
 ventilation air damper setting (if active).....angle 108
 manual inputs.....alpha-numeric 121.

In addition the AHU controller sends information to and receives information from the various zone controllers and maintains communication with the central building system controller 118 via the building
 35 Local Area Network (LAN) 140.

Fig. 7 shows diagrammatically one possible configuration of the dehumidifier 102, which comprises three coil rows each with eight passes. It will be seen from Fig. 7 how, even with minimum effective size, the full area of air flow always intercepts active cooling coils. By bypassing flow in some coils (bypass tubes 135), high coolant velocity is maintained (U.S. patent 4942740).

40 The following sets forth the control system:

Reference is made to Figs. 8 and 9:

Each zone served by an air handling unit has a local controller, preferably but not essentially of the programmable type. At the minimum level of control a zone thermostat which is manually adjustable according to a table of settings is required. The following description relates to the use of a programmable
 45 controller in the absence of direct sensing of humidity. With humidity sensing the complete comfort equation and predicted mean vote can be solved as detailed earlier in this specification.

Two types of factors are required as inputs by the control system; physical/environmental factors and personal factors relating to the occupants. Factors of the first type may be sensed by conventional means. Factors of the second type may be deduced with the aid of tabulated data.

50 The local zone control function requires

- (a) estimation of the zone sensible load,
- (b) estimation of the actual operative temperature in the zone,
- (c) computation of the optimum and acceptable range of operative temperature,
- (d) determination of the 'offset' between (b) and the optimum,
- 55 (e) initiation of action to bring the 'offset' within the acceptable range.

The above functions are embodied in the zone control logic diagram, Fig. 8, for a VAV system. In the most preferred embodiment the optimum air temperature in the zone is calculated directly from the comfort equation to yield $L = 0$. Both humidity and mean radiant sensors must be fitted for this embodiment.

We now consider each of the above control requirements in turn:

(a) The zone sensible load may be obtained from measurements of the volume flow rate q_s of the supply air (obtained either from the measurement of the pressure difference across some known constriction or from knowledge of the flow characteristic as a function of supply air damper angle for a measured supply air pressure) and measurement of the rise in temperature of the supply air between inlet to and outlet from the zone. The zone sensible load is then calculated from $Q_s = \rho_s q_s c_p (t_a - t_s)$ where ρ_s is the density of the supply air, c_p is the specific heat of the air and t_a , t_s are the temperatures of the return (room) and supply air respectively. This expression can be recognised as the familiar relationship $Q_s = mc_p \Delta t$ where m is the mass flow rate of air and Δt is the temperature difference across the load.

(b) The actual operative temperature is approximately equal to the average of the mean radiant temperature t_r and the temperature t_a of the air in the room. The room air temperature may be measured directly by conventional means. The mean radiant temperature t_r is the uniform temperature of the surface of a radiantly black enclosure in which the occupant would exchange the same amount of heat by radiation as in the actual non-uniform room. It can be calculated if the room geometry and the temperatures of all surfaces are known. Such information is seldom known and hence approximations are necessary. The mean radiant temperature can, however, be derived from measurements of the air temperature, the relative velocity of air movement v and the "globe temperature" t_g . The latter is the temperature measured at the centre of a six inch (0.15m) diameter thin walled non-reflective sphere. The mean radiant temperature is then calculated from

$$t_r = t_g + k \sqrt{v} (t_g - t_a)$$

where temperatures are expressed in Celsius degrees, velocity is in metres per second and $k = 2.2$.

It has been found in tests that natural convection places a lower limiting value on the velocity v . Thus the above equation should carry the qualifying statement " $v \geq 0.05$ m/s".

If the diameter, d , of the globe thermometer sphere differs from 0.15m, the value of k is adjusted according to the equation

$$k_d = k (0.15/d)^{0.4}$$

A.P. Gagge, G.M. Rappe and J. D. Hardy (ASHRAE Inc, May 1967, p.63) showed that if the outer surface of the standard globe is painted a skin colour, the temperature measured at its centre closely approximates the operative temperature. However the time constant for such a sensor is of the order of 30 minutes which, apart from its obtrusive bulk, makes it unsuitable as a control sensor in a practical air conditioning system. An integral part of the control system of the present invention is the use of unobtrusive miniature direct measuring operative or globe temperature sensors with short time constants. The relative velocity at the miniature globe location is measured during commissioning of the system. By this means a good approximation to the mean radiant temperature may be obtained. In practice several miniature globes are used to sample the distribution of mean radiant temperature through the zone. ASHRAE Standard 55-1981 specifies the locations at which measurements should be made.

(c) The optimum operative temperature is that operative temperature which satisfies the greatest number of similarly clad occupants in a given room for a given relative humidity and given relative velocity. The acceptable range of operative temperatures for these subjects is variously defined but ASHRAE Standard 55-1981 specifies acceptability as being the band of conditions within which eighty per cent of occupants are slightly cool, neutral or slightly warm. It is possible to determine this band by calculation from the "comfort equation" and reference to statistical data derived from the responses of many volunteers who participated in tests, as described earlier in this specification. In the proposed revision of the Standard, designated (55-1981R), the acceptance criterion has been raised to ninety per cent. The present embodiment further allows for the most probable range of clothing worn by occupants at a given time.

(d) The "offset" between the calculated operative temperature and the optimum operative temperature is obtained by simple difference. This difference is then compared with the "acceptable range" of operative temperatures.

(e) If the offset is not within the acceptable range the control system then initiates corrective action by changing the air temperature in the zone. Typically this would involve an increase or decrease of the air flow to the zone which could be achieved by the opening or closing of the supply air damper in the duct leading to the particular zone.

Note that items (b) and (c) require a knowledge of the insulating values of the range of clothing most likely to be being worn by the occupants of the building or of a particular room or zone of the building. Several means by which this may be determined or estimated may be envisaged. For example, in some zones within a building the occupants may all be required to wear a particular uniform or protective clothing at all times. The insulation value, measured in the units of clo where 1 clo = 0.155m² K/W, can be accurately measured and then becomes a unique value in the calculations. For such a circumstance the

range of acceptable temperature is a maximum.

By contrast, in a typical office building or department store the range of clothing worn by the occupants is usually diverse. It would be possible for a doorman with a trained eye to assess the range of clothing being worn as employees arrive at work. This information could then be translated into a range of clo values. The wider the range of clo values to be accommodated, the narrower is the range of temperatures which are acceptable.

An alternative to use of the observing skills of a doorman would be to estimate the most probable range of clothing being worn. The choice of clothing depends on the local culture, on the type of activity, on the time of year and on the early morning weather forecast. Within a given culture and type of activity, the time of year can be determined from the block within the computer or controller and the likely variation about the clothing typical of that time of year is dependent largely on the outside ambient temperature, which can be measured directly. Thus estimates of the likely range of clo values for that particular day may be made. It is good practice to err on the high side in making this estimate during the cooling period as it is usually easier for a well clad person to remove a coat or jacket than for a lightly clad person to find means to keep warm.

In addition to the local zone controls, the Air Handling Unit operation is also supervised by a controller. At the simpler level this controller is an air-off thermostat, which actuates a valve or valves to adjust the flow of coolant through the dehumidifier coil so to maintain the air-off temperature constant, and conventional means of measuring and controlling the air supply volume for a VAV system, or to keep the zone temperature at the set point determined by the zone controller for the CAV system. It is better practice for the controller to be a programmable controller which receives data from each of the zone controllers and, from a pre-programmed "performance map" for the particular system, determines the optimum combination of operating point for the air flow fan, active coil area, coolant flow rate and, in the case of a direct expansion (DX) system, the speed of the compressor.

The control system described herein maintains an ongoing record of past actions and of the results of those actions. These data can be used to update and refine the aforesaid performance map.

Referring now to the logic diagram for a VAV System, Fig. 8, the air flow volume q_s is proportional to Δp and is calculated by the controller according to the formula

$$q_s = K_1 \sqrt{p}$$

where K_1 is a proportionality constant determined during design or during commissioning. Alternatively q_s could be calculated from a flow vs damper angle calibration.

From the measurement of q_s may be obtained the quantity $m c_p = c_p q_s$, where m = mass flow rate of air and

$\rho_s c_p$ = specific heat of air.

ρ_s = density of supply air.

This quantity, when multiplied by the difference between the measured temperatures of the air leaving the zone t_a and the air supplied to the zone t_s , yields the zone sensible heat load Q_s , as indicated earlier.

From knowledge of the thermal characteristics of the building, determined during design or measured on site, and measurement of the ambient temperature, an estimate can be made of the part of the sensible heat load Q_s which is due to transmission of heat through the walls, windows and, where appropriate, roof of the building. Thus

$Q_{strans} = K_3(t_{amb} - t_a)$, where K_3 is the relevant factor in the building characteristic. Allowance could if necessary be made for direct sun load on the wall or roof of the building.

It should be noted that the thermal mass of the building fabric will cause the building to respond only slowly to changes in either ambient or room temperature. Thus the actual value of Q_{strans} at any given time will be determined by the values of t_{amb} and t_a at earlier and usually different times. For this reason these values are stored and then retrieved after a time delay determined by the building time constant. The values of Q_{strans} are similarly stored for use in determining the internally generated sensible load in the zone as a function of time. This information is of value to building managers for planning purposes. Also, in a lightly constructed building as are many existing office buildings, the building time constant is short and the effects of changing the internal air temperature cause the transmitted sensible load to change after only a short time. In these circumstances it is appropriate to anticipate the change by computing a new sensible heat load as follows:

$$\text{old } Q_s = \text{old } Q_{sinternal} + \text{old } Q_{strans}$$

$$\text{new } Q_s = \text{new } Q_{sinternal} + \text{new } Q_{strans}$$

$$\text{But old } Q_{sinternal} = \text{new } Q_{sinternal}$$

$$\text{Hence new } Q_s =$$

$$\text{old } Q_s - \text{old } Q_{strans} + \text{new } Q_{strans}$$

$$= \text{old } Q_s - K_3 (t_{\text{arqd}} - t_a)$$

where t_{arqd} is the new required air temperature and t_a is the existing air temperature.

From the new Q_s the required supply air quantity can be calculated from

$$(mc_p)_{\text{rqd}} = \text{new } Q_s / (t_{\text{arqd}} - t_a)$$

5

$$\text{or } q_{\text{srqd}} = \frac{\text{old } Q_s}{\rho_s c_p (t_{\text{arqd}} - t_a)} - K_3 / \rho_s c_p$$

10

The zone dampers can then be adjusted and information relayed to the AHU controller.

As an example of the many additional capabilities of the type of control system described herein, any discrepancy between the actual damper angle (ϕ), and the angle determined by the controller can be reported immediately to the computer based maintenance log. Limit alarms may be set and operating costs can be accurately recorded and reported in a readily understandable form.

15

As a further feature of the control strategy of the present invention, when used in association with the LFV/HCV method of air conditioning which is the subject of US Patent 4942740, where the occupancy of the zones served by an AHU falls to zero in the evening, the system can be set to run on a maximum dehumidification cycle for a defined period to dry out all ducts, carpets, fabrics and papers. This may be achieved by operating with maximum coolant velocity in the portion of the coil which operates at minimum load, and reducing the face velocity, and hence the air flow volume, to not more than 0.5 metres per second. This procedure eliminates the possibility of mould or bacterial growth in the ductwork and on the building fabric and furnishings.

20

The air handling unit (AHU) controller receives information from all local controllers (Fig. 8), adds together the sensible heat loads and the volumes of air demanded, sets the ventilation air quantity on the basis of the needs of the most lightly loaded zone and calculates the best combination of effective dehumidifier size, coolant flow rate, fan speed and main supply air damper position to satisfy the air supply needs of the conditioned zones. A time delay ensures that zone dampers are set after the setting of the AHU parameters. For a DX system the compressor speed (suction pressure) is also optimised.

25

When radiation is important the air temperature does not equal the operative temperature and the diurnal and seasonal variations then ideally require a measure of mean radiant temperature, or a direct measurement of operative temperature, to be input to the control system, as indicated above. Nevertheless it is possible to achieve improved results from cheaper options such as allowing sensible load only to determine the room temperature, or the least expensive option of all, relying on the manual adjustment of each zone or room thermostat setting according to tabulated or calculated values derived from the comfort equation.

30

The control logic for a CAV system, Fig. 9, differs from that for the VAV system, Fig. 8, only in the control action which is taken. Where the action taken in the VAV system is to adjust a damper angle and report data to the AHU controller, the CAV control system (which will usually be an integral part of the AHU control system) reports to the AHU controller the air temperature required in the zone to achieve the required operative temperature. The AHU controller then determines from the requirements of other zones, if any the optimum supply air temperature to minimise the reheat throughout the system.

35

The following sets forth a constant air volume (CAV) system with comfort integration:

In the comparative analysis above with and without comfort integration, discussion has concentrated on a LFV-HCV-VAV system. This is because such a system now represents "best practice", as it combines low energy consumption and broad multizone capabilities. However, although the simultaneous air quantity required at any part of the diurnal cycle may not vary greatly because of the diversity in the demands of individual zones within a multizone VAV system, this very factor may reduce the air change rate in some low load zones below the necessary ventilation levels. The constant air volume (CAV) system does not suffer from this problem.

40

45

50

In the conventional CAV air conditioning system the air flow rate is kept constant to all areas served and all areas are sufficiently similar for them to be treated as a single zone. The coolant flow rate is throttled with reduction in load, as in the case of the VAV system, but unlike the VAV system the leaving dry bulb temperature from the coil is allowed to rise to maintain a fixed room dry bulb temperature. This characteristic of the CAV system has an adverse effect on part load performance. The slope of the coil condition curve decreases during part load conditions resulting in reduced dehumidification per unit of cooling; this is precisely the opposite of that which is required to offset the lower sensible heat ratio. It is for this reason that in the past CAV systems have often employed overcooling to satisfy latent heat load and

55

reheating to re-balance the sensible heat load. Where several zones are served by the one dehumidifier coil and zone differences are significant, practice has been to satisfy that zone requiring the lowest supply air temperature and to reheat the air as it is admitted to each other zone to achieve the required air condition in that zone. While the degree of comfort which can be achieved by such a system may be good, it uses
 5 energy at a rate which is now considered unacceptable for other than special applications by most responsible designers.

In the application of the comfort integration of this invention to a CAV system, which ideally should not be faced with zone diversity, rather than adapting to the sensible load by varying the sensible temperature of the supply air, supply air temperature and dehumidifier capacity are initially held substantially constant
 10 while the room or zone thermostat or controller is first reset to offset the load and to achieve as closely as possible the required operative temperature. If insufficient control is available by this means, and coil size is fixed, coolant flow through the dehumidifier is varied to result in a change in supply air temperature. This strategy maintains dehumidification capacity more effectively than does conventional practice. If zone diversity is present, part load rooms or zones are set to maintain a lower temperature than are peak load
 15 rooms. Terminal reheat requirements are thus reduced to "trimming".

Where a constant air volume system serves several zones these zones should, according to good design practice have very nearly the same behaviour of thermal load conditions. Where variations do occur, the zone with the consistently least thermal load would serve as a master zone governing all the zones on the same system and would determine the sensible temperature setting in that "master" zone. However
 20 reheat coils would be provided to the associated similar zones to permit adjustment of room temperatures to the same room sensible setting. Only when these other rooms have different mean radiant temperatures would it be necessary too to have variable room temperature thermostats to establish the appropriate room sensible setting given the mean radiant temperature and the seasonal operative temperature.

In lightly loaded interior zones it is known that the mean radiant temperature is equal to the room
 25 sensible temperature in which case the seasonal operative temperature will also be equal to the "master" zone sensible temperature setting and no separate measurement of mean radiant temperature is required. If perimeter zones are involved, measurement of radiant temperature in one zone only, together with predetermined information on diurnal diversity and tabulation of the typical seasonal operative temperatures will allow automatic (or manual) determination of the required room sensible temperature setting without the
 30 need for additional globe thermometers. The required room sensible temperature will be established through control of the chilled water throttling valve. The temperature regulating means and valves controlled by the controller operate in such manner as to limit the range of temperatures within the conditioned space to between 22 °C and 27 °C as established by comfort standards.

Although the systems described use more energy than do the VAV systems for the same duties, they
 35 are far less wasteful than the conventional CAV system which seeks to maintain a constant room dry bulb temperature in all rooms at all times. The important difference between the conventional CAV system and the CAV system with comfort integration is that in the latter the coil condition curve initially becomes steeper as load decreases so allowing the latent load to be offset without the need for such severe overcooling as that required by the conventional system.

40 The invention has further advantages:

In addition to satisfying thermal loads successfully and achieving optimum comfort, an examination of Table 1 reveals several further advantages contributed by the method of this invention. Here the same system of air conditioning, the LFV HCV-VAV system, is compared for the same design specification for the same office building, with and without comfort integration.

45 (a) The air handling unit supply air fan is smaller. Within the present invention the air fan is selected for only 4800 LPS as compared with the system designed without comfort integration which requires 6000 LPS. This reduces capital cost and running cost. The reduced size of the supply air fan results from the increased temperature difference across the room allowed by ASHRAE 55-1981 and a reduction in the heat transmission to the rooms due to the smaller temperature difference between outside and inside
 50 conditions during peak load conditions. In the case of the example shown in Table 1, the difference across the room load ratio line from [24 °C-12.4 °C] = 11.6 °C to [26 °C-12.4 °C] = 13.6 °C reduces the 6000 LPS requirement to $11.6/13.6 \times 6000 = 5118$ LPS.

(b) There is also a reduction in the cooling load. The heat transferred to the perimeter rooms by transmission from the outside is reduced. Conservatively the transmission gains account for 25 per cent
 55 of the cooling load and the transmission temperature difference due to the higher 26 °C room temperature is reduced by 25 per cent. Thus, (0.25 x 0.25) or 6.25 per cent of the sensible load is eliminated. Therefore at peak load the volume flow rate can be further reduced to $5118 (1-.0625) = 4800$ LPS.

(c) The multizone capability of the VAV system is increased. To indicate how well an air handling unit according to the present invention can accommodate widely diverse zonal loads, consider a multizone unit under simultaneous peak design load conditions. Three zones only are considered for simplicity; a nine zone system with each zone having provision for separate selection of clothing insulation value has recently been designed.

In the earlier comparison of Table 1, to demonstrate the human comfort conditions anticipated by the method of the present invention, the performance of a single zone only was considered. The three operating conditions were presented as if each related to a separate zone serviced by a separate, dedicated air handling unit. However it is the simultaneous design peak load performance which in practice determines the selection of the coil and the fan in an air handling unit designed to service several zones. The simultaneous peak load including all zones is always less than the sum of the individual zonal peak loads and hence smaller components and less energy are required than would be required to satisfy the sum of the maximum loads in each zone, a feature which is already well known to designers. To select the air handling unit we will assume for the purpose of this illustration that the three coil stages listed in Table 1 occur simultaneously and together set the simultaneous peak design load. We also assume that the individual peak load energies, which occur at different times in each of the three zones, are equal. One can visualize that the air handling unit reaches the simultaneous peak load at 4 pm in the afternoon of a midsummer day. Assume on the basis of typical figures for a high rise building that the 100% load stage indicated in Table 1 represents the west zone and that this zone consumes 55 per cent of the total air handling unit energy. The north, south and east facades are combined to form a second zone which at 4 pm is operating at an average of 60 per cent of the maximum load in this second zone, and is found to consume 35 per cent of the air handling unit energy. The interior of the building is the third zone which at the time of the simultaneous peak load is operating at its almost steady state level of ten percent of the air handling unit energy.

In Table 1 it was assumed that the two part-load zones of 65 per cent and 50 per cent occurred on marginal weather days when occupants would be attired with medium clothing. These two part load zones are now considered simultaneously with the peak summer design day and therefore the control system, knowing the time of year and sensing the ambient air temperature, t_{amb} , of 36°C (see lower left corner of Fig. 8 Control Diagram) establishes the appropriate range of clo values. These are then used to adjust the operative temperature to its optimum value of 24.5°C to achieve a comfortable environment for the lightly attired occupants of these zones. (In the earlier example the operative temperature for these zones was only 23°C , the difference being due to the heavier clothing worn by the occupants during the marginal weather season). Table 2 indicates the simultaneous peak performance. The volume flow rate required with Comfort Integration is further reduced to 4136 LPS. For comparison, the LFV-HCV-VAV system without Comfort Integration would require, for the same simultaneous peak design, 4965 LPS of conditioned supply air. The ratio of the two requirements in this case is similar to that found in the Table 1 comparison. It should be stressed that this example is a particular hypothetical case and the numerical values could vary considerably. The following comparison should therefore be treated as being qualitative only:

(a) The reduced peak load means a smaller chiller, cooling tower, piping and ductwork.
 (b) There is an advantage in dehumidifier design. The reduced volume flow rate of the supply air means a smaller face area coil can be used. Alternatively, if peak loads are associated with low sensible heat ratios, as on the Eastern seaboard of the United States and in the tropics, the advantage of a further reduction in face velocity through the larger coil face area can be utilized in the selection for 4136 LPS to give a steeper slope to the coil condition curve and so to increase dehumidification. In this circumstance it is sometimes possible to reduce the number of rows of depth of the coil.

(c) There is a greater flexibility in design. The addition of comfort integration to the system provides a wider range of multizone performance in that each room has its preferred operative temperature and its preferred relative velocity. Thus fewer air handling units may be required.

(d) The "Coanda effect" in slot distribution registers is preserved at low loads. When the VAV system is employed over a range from peak to say 50 per cent of sensible load, there is a danger that the Coanda effect may be lost due to low air flow through the registers, resulting in "dumping" of cold supply air and considerable consequent discomfort. As indicated in Table 1 the volume ratio between the peak and the 50 per cent part load operation is 0.5 for the system without comfort integration, but is 0.64 with comfort integration. A drop from 6000 LPS to 3000 LPS may be a problem. However a drop from 4800 LPS to 3080 is unlikely to disturb the Coanda Effect (see Table 1).

(e) Wasteful use of energy in inefficient fan assisted VAV boxes is eliminated. Fan assisted VAV boxes are used to increase the supply air quantity at low loads to maintain the Coanda effect and to increase air movement and obtain a degree of reheat by blending a proportion of warm return air with the

conditioned supply air. This design practice increases the cost of the VAV boxes and also increases the operating cost since the small fans are inefficient. Furthermore unfiltered return air can be unhealthy especially if photocopiers or smokers are located in the zone (Fanger, 1987). In the "comfort integrated" system the decreased peak air flow rate coupled with an increased minimum air flow rate eliminates the need for this mostly and inadequate solution.

5 (f) There is improved ventilation to the air conditioned rooms. This is a side benefit arising from the increase in the supply air volume flow ratio between part load rooms and peak load rooms. Even if conventional VAV systems increase the overall ratio of outside air to return air passing through the air handling unit during marginal weather, the minimum part load rooms will still receive a smaller volume of outside air than do the simultaneously higher part load rooms.

10 (g) Air conditioning performance is improved over those systems designed to reset their supply air temperatures upwards during marginal weather. In order to increase the supply air volume to low part load rooms, reset of the temperature of the supply air leaving the dehumidifier coil is common. Wherever humidity is a significant factor this is poor practice since the lower part load rooms characteristically have the lower sensible heat ratios and therefore demand more dehumidification. Upward reset of the supply air temperature is associated with a higher surface temperature at the dehumidifier which reduces the dehumidification. Furthermore rooms which experience an increase in load during the period of upward reset may not be able to have them offset. With the comfort integration of the present invention, the supply air temperature remains constant and rooms with very low loads have their operative temperature decreased automatically, with the result that they receive an increased air supply and the required level of dehumidification can be achieved.

25

30

35

40

45

50

55

TABLE 1
 PROJECTED ZONE PERFORMANCE IN A DESIGN FOR A PERTH, WEST
 AUSTRALIA HIGH RISE OFFICE BUILDING

	With Comfort Integration of this Invention	Without Comfort Integration of this Invention
FULL COIL STAGE		
During 100% load		
Rm dbt °C*	26°C	24°C
Supply air dbt °C	12.4	12.4
Rm W g/kg	9.28	9
Rm RH %	44%	48%
Sim. Supply Air LPS	4800	6000
Rm Sens Load kw	79	83
Rm SHR	0.87	0.87
Tot Cooling Capacity kw	110	116
Tot Water LPS	3.6	4.0
PART COIL STAGE		
65% Load		
Rm dbt °C*	23	24
Supply Air dbt °C	12.4	12.4
Rm W g/kg	10.6	10.6
Rm RH %	60%	57%
Supply Air Vol LPS	4000	3900
Rm Sens Load kw	51.0	54.3
Rm SHR	0.65	0.67
Tot. Cooling kw	88.4	90.2
Tot. Water LPS	4.5	4.5
Peak to 65% Part Load		
Supply Volume RATIO	1.20	1.54
PART COIL STAGE		
50%		
Rm dbt °C*	22.8	24
Supply Air dbt °C	12.4	12.4
Rm W g/kg	11.3	11.5
Rm RH %	64%	61%
Sup Air Vol LPS	3080	3000
Rm Sens Load kw	39.6	42.0
Rm SHR	0.60	0.60
Tot. Cooling kw	7.10	74.9
Tot. Water LPS	2.8	3.0
Peak to 50% Part Load		
Supply Volume RATIO	1.56	2.00

* As indicated on Fig. 3 charts it is assumed air dry bulb temperature, t_a = mean radiant temperature, t_r .

TABLE 2

PROJECTED PERFORMANCE OF AIR HANDLING UNIT AT SIMULTANEOUS PEAK				
	With Comfort Integration		Without Comfort Integration	
	kw	LPS	Kw	LPS
West Zone at 55 per cent of A.H.U. Load	60.5	2640	63.8	3300
East, North & South Zones at 35 per cent of A.H.U. Load	31.0	1232	31.5	1365
Interior Zones at 10 per cent of A.H.U. Load	7.0	264	7.6	300
TOTAL	98.5	4136	102.9	4965

Claims

1. A method of cooling a space by air conditioning said space within a relatively narrow comfort target zone as depicted on a psychrometric type chart, itself generally within a relatively broad standard comfort zone, the factors determining said narrow target zone including the heat transfer resistance of occupants' clothing and level of physical activity, the method comprising:
 - determining air dry bulb temperature and at least one of mean radiant temperature and operative temperature in said conditioned space, and controlling:
 - (a) one at least of temperature of supply air to said space, and dry bulb air temperature leaving said space,
 - (b) effective size of said dehumidifier while maintaining coolant velocity through said dehumidifier to be between the equivalent of 1 and 2.2 metres per second of chilled water, and
 - (c) humidity ratio in said conditioned space to be between four and thirteen grams of water vapour per kilogram of dry air by varying at least one of leaving temperature of the supply air from, and effective size of and coolant flow velocity in, said dehumidifier.
2. A method according to claim 1 wherein said operative temperature within said conditioned space is controlled by determining said mean radiant and said air dry bulb temperatures and adjusting said air dry bulb temperature to be less than the operative temperature by the same amount as the mean radiant temperature exceeds said operative temperature.
3. A method according to claim 1 wherein said mean radiant temperature within said conditioned space is determined and further comprising controlling temperature of supply air to said conditioned space to be sufficiently cool to offset the sensible heat load and the effect of said mean radiant temperature on the thermal comfort of occupants within said space, and controlling said relative air velocity over occupants to be compatible with the operative temperature required for said thermal comfort.
4. A method according to claim 1 wherein said dehumidifier comprises a plurality of coil portions, a plurality of coil valves interconnecting said coil portions, a plurality of coil bypass tubes, and a throttle valve, said coil portions, coil valves and coil bypass tubes being in a configuration controllable to vary the effective cooling size of said dehumidifier, said method comprising effecting control of said coil valves to bypass flow selectively from portions of the dehumidifier coil through said coil bypass tubes to reduce the effective cooling capacity of the dehumidifier upon reduction of load, but retain said coolant flow through said coil portions to be the equivalent of between 1 and 2.2 metres per second of coolant.
5. A method according to claim 4 wherein said air conditioner comprises a fan which causes air flow through said dehumidifier, said method comprising limiting said air flow to be sufficiently low that humidity ratio within said conditioned space does not exceed thirteen grams of water per kilogram of dry air, but is not less than four grams per kilogram.
6. A method according to claim 4 wherein said air conditioner comprises a fan which causes air flow through a plurality of rows of said dehumidifier coil, and the configuration of said coil portions is such that said bypass of coil portions is effected while retaining active coil portions over the whole of a path of said

air flow through said rows of dehumidifier coil.

7. A method according to claim 1 further comprising determining volume flow rate of air through said conditioned space, globe thermometer temperature in relevant portions of said conditioned space, and ambient temperature, computing operative temperature, comparing said computed operative temperature with a temperature in said narrow comfort target zone, and effecting adjustment of one at least of (a), (b) and (c) of the steps of claim 1 as required to maintain said space within said narrow comfort target zone.

8. A method according to claim 1 further comprising determining volume flow rate of air through said conditioned space, globe thermometer temperature in relevant portions of said conditioned space where said globe temperature differs from said air temperature, ambient air temperature, at least one of relative humidity, dew point and humidity ratio in said conditioned space, computing the thermal energy balance for at least one occupant of said space to determine the equilibrium air temperature at which said occupants would be in thermal equilibrium with the environment of said space, and adjusting said air temperature to said equilibrium value while maintaining at least one of humidity ratio between 4.2 and 12 grams of water per kilogram of dry air and relative humidity between 30 and 60 percent.

9. A method of cooling an air conditioned space comprising:

- (a) causing a flow of air through cooling coils of an air conditioner dehumidifier,
- (b) determining at least one of air flow velocity and air volume flow rate,
- (c) sensing dry bulb temperature in said conditioned space and globe thermometer temperature in at least one part of said conditioned space when air and globe temperatures differ therein,
- (d) sensing ambient air temperature,
- (e) providing an electronic controller with input data from (b), (c) and (d) hereof,
- (f) computing with said controller air supply volume and operative temperature and comparing relative air velocity over occupants and said computed operative temperature with a comfort target zone for humans depicting combinations of relative air velocity and operative temperature which have been determined by solution of the thermal energy balance equation which includes heat transfer resistance of occupants clothing and level of physical activity, and the convective, radiative and evaporative exchanges of energy between the occupants and their surroundings,
- (g) adjusting at least one of air supply to said space and supply air temperature to retain said space within said narrow target zone.

10. A method according to claim 1 further comprising effecting said control so that the conditions in said conditioned space require the ratio of air flow in a variable air volume system for fifty percent of the peak sensible heat load to that for said peak sensible heat load to be not less than 0.65.

11. A method according to claim 4 wherein the space is conditioned by a constant air volume system comprising effecting said control by initially maintaining supply air temperature and dehumidifier capacity constant and resetting said air dry bulb temperature in the conditioned space, until the temperature in said conditioned space approaches limits of said narrow comfort zone, and then effecting said control of said coil valves to vary size of said dehumidifier.

12. A method of controlling an air conditioning system, comprising receiving information defining occupant activity, and including:

- (a) supply and return air dry bulb temperature,
 - (b) at least one of globe temperature and operative temperature,
 - (c) at least one of a measure and estimate of relative humidity,
 - (d) at least one of supply air volume flow rate and air velocity and available air flow area and a pressure difference, (e) time of day and day of year and date defining:
 - (f) the most probable range of clothing worn by occupants of the conditioned space for representative seasonal and ambient conditions,
 - (g) the range of insulation values of clothing types,
 - (h) the metabolic energy release rate and the external work done for a representative range of activities,
- and selecting appropriate values of metabolic energy release rate, external work output and clothing insulation, computing from a balance between net metabolic heat generation by the occupant and the rate at which it is exchanged with the surroundings within said conditioned space, the change in dry bulb air temperature and relative humidity in said conditioned space necessary to make said rate of heat exchange with the surroundings equal to said net metabolic heat generation by the occupant within a small tolerance range defined by reference to the statistical results of studies of human responses to thermal environments, and

initiating action to change said air temperature and relative humidity by changing at least one of supply air flow rate and active size of dehumidifier, coolant flow rate, and supply air temperature to maintain the

conditioned space within said tolerance range.

13. A method according to claim 12 further comprising calculating the change in sensible heat load in the conditioned space due to the changes in the transmitted heat load and changes in the rates of heat removed from equipment and occupants within said space consequent upon said changes in temperature and relative humidity within said space and employing said calculations in determining the optimum strategy by which said changes are effected.

14. A method according to claim 13 further effecting change in relative air velocity to maintain the conditioned space within said tolerance band.

15. A method according to claim 13 further comprising recording both said interrogated and computed data.

16. A method according to claim 13 wherein said computed balance between net metabolic heat generation by the occupant and the rate at which it is exchanged with the surroundings within said conditioned space is computed from the equation derived by P.O. Fanger and known as the comfort equation and published in the ASHRAE Fundamentals Handbook, 1989, and said tolerance in said balance is evaluated from the condition that the quantity known as the Predicted Mean Vote and published in said ASHRAE handbook shall not be less than -0.5 or greater than +0.5.

17. An air conditioner for cooling a conditioned space within a relatively narrow comfort target zone as depicted on a psychrometric type chart, itself generally within a relatively broad standard comfort zone, the factors determining said target zone including the heat transfer resistance of occupants clothing and level of physical activity, comprising:

a dehumidifier having a plurality of coil portions, a fan located to propel air flow through said coil portions, temperature sensing means comprising a thermometer arranged to ascertain at least one of mean radiant temperature and operative temperature in said conditioned space, humidity sensing means in said conditioned space, and:

(a) air control means controlling relative air velocity within occupied regions of said space to lie between 0.05 and 0.30 metres per second, but said air not to exceed a velocity of three metres per second through a face of an air conditioner dehumidifier,

(b) temperature control means controlling the temperature of supply air to said space, and dry bulb air temperature within said space,

(c) coolant control valve means controlling effective size of said dehumidifier while maintaining coolant velocity through said dehumidifier to between the equivalent of 1 and 2.2 metres per second, and

(d) humidity control means coupled to said humidity sensor and to at least one of said temperature control means and coolant control valves to control humidity ratio in said conditioned space to be between four and thirteen grams of water vapour per kilogram of dry air by varying at least one of leaving temperature of the supply air from, effective size of, and coolant flow velocity, said dehumidifier when said humidity ratio approaches said four grams per kilogram.

18. An air conditioner according to claim 17 wherein said temperature sensing means comprise dry bulb thermometers in supply air to and return air from said conditioned space, and further comprising air flow rate sensing means, ambient air temperature sensing means,

and an electronic controller interconnecting said sensing means and control means to effect control of said relative air velocity, dry bulb temperature in said space, supply air temperature, effective dehumidifier size and minimum and maximum humidity in said space.

19. An air conditioner according to claim 18 wherein said air control means comprises dampers located between said dehumidifier and said conditioned space, and motors coupled to said dampers to control air flow therethrough, and said electronic controller limits relative air velocity to between 0.05 and 0.30 metres per second through the conditioned space.

20. An air conditioner according to claim 18 wherein said temperature control means comprises said coolant control valve means and said electronic controller varies the number of active coil portions of said dehumidifier to retain coolant velocity through said active coils between 1 and 2.2 metres per second.

21. An air conditioner according to claim 18 wherein said controller increases the leaving temperature of the supply air when the humidity ratio drops to four grams of water vapour per kilogram of dry air.

22. An air conditioner according to claim 18 wherein said air control means comprises fan speed control means effected through communication between said air flow control means and said electronic control means.

23. An air conditioner according to claim 17 wherein said control means are components of an air handling unit, and said air conditioned space comprises a plurality of separate zones, comprising further said sensing means in each of at least some of said zones, and communication means between said further sensing means and said air handling unit.

24. An air conditioner according to claim 18 wherein the fan and air control means co-operate to deliver ventilation air to said conditioned space at the rate of not less than 7.5 litres of ventilation air per person said ventilation air being that portion of the supply air drawn from outside the building and mixed with recirculated air prior to its passing through the dehumidifier.

5 25. An air conditioner according to claim 13 wherein said electronic controller is programmed to reduce the velocity of air flow through a face of a dehumidifier to not more than 0.5 metres per second and to cause coolant to flow through the tubes of at least part of said dehumidifier at a velocity of not less than 1.0 metres per second and not more than 2.2 metres per second for at least part of a period during which said
10 conditioned space is not occupied, such procedure allowing the humidity ratio of the air to reduce to a minimum value without inhibition and thus to dry all deposits of water from the air distribution system and to reduce the moisture content of the building fabric and furnishings within said conditioned space.

15

20

25

30

35

40

45

50

55

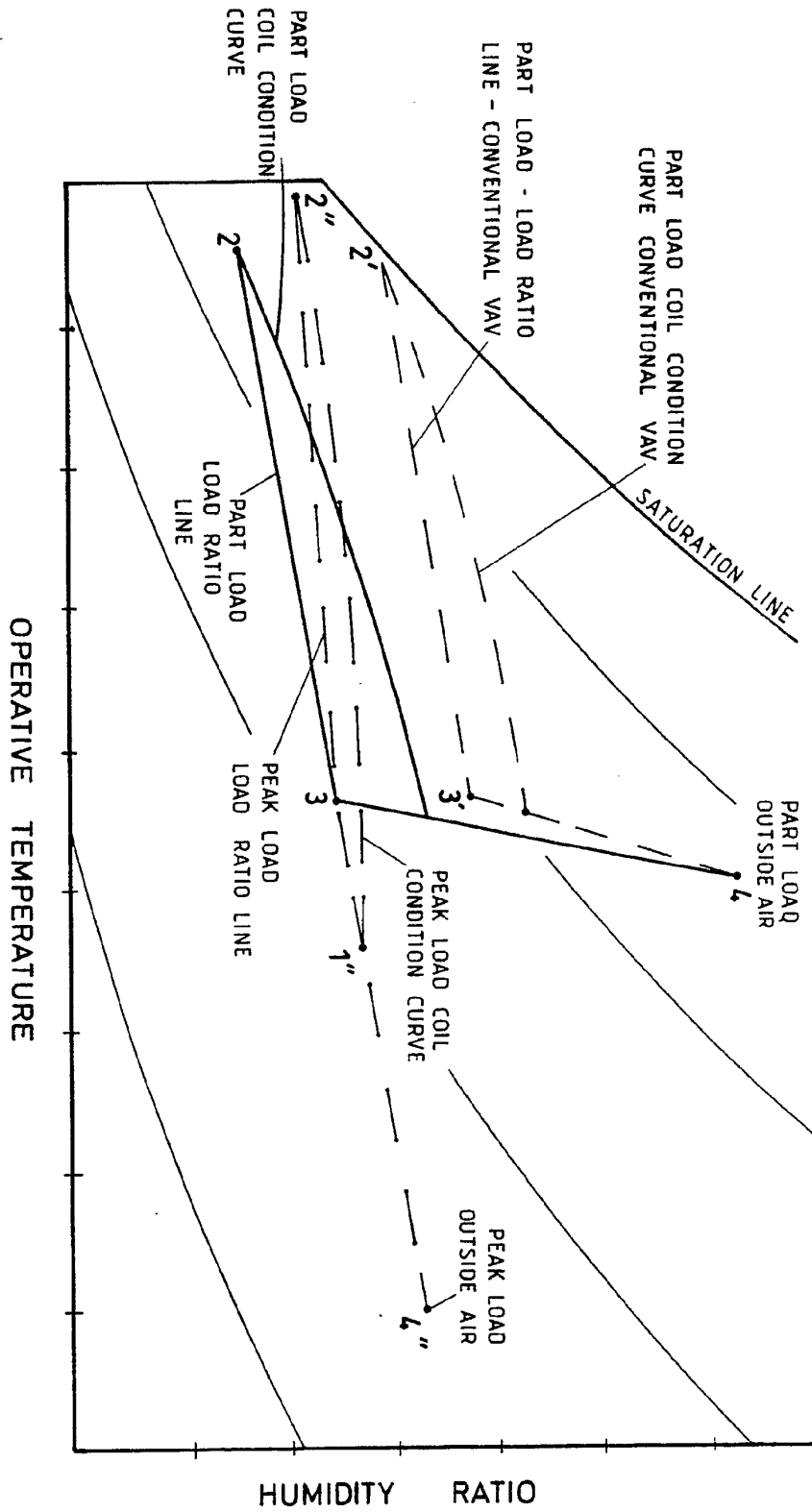

FIG 1

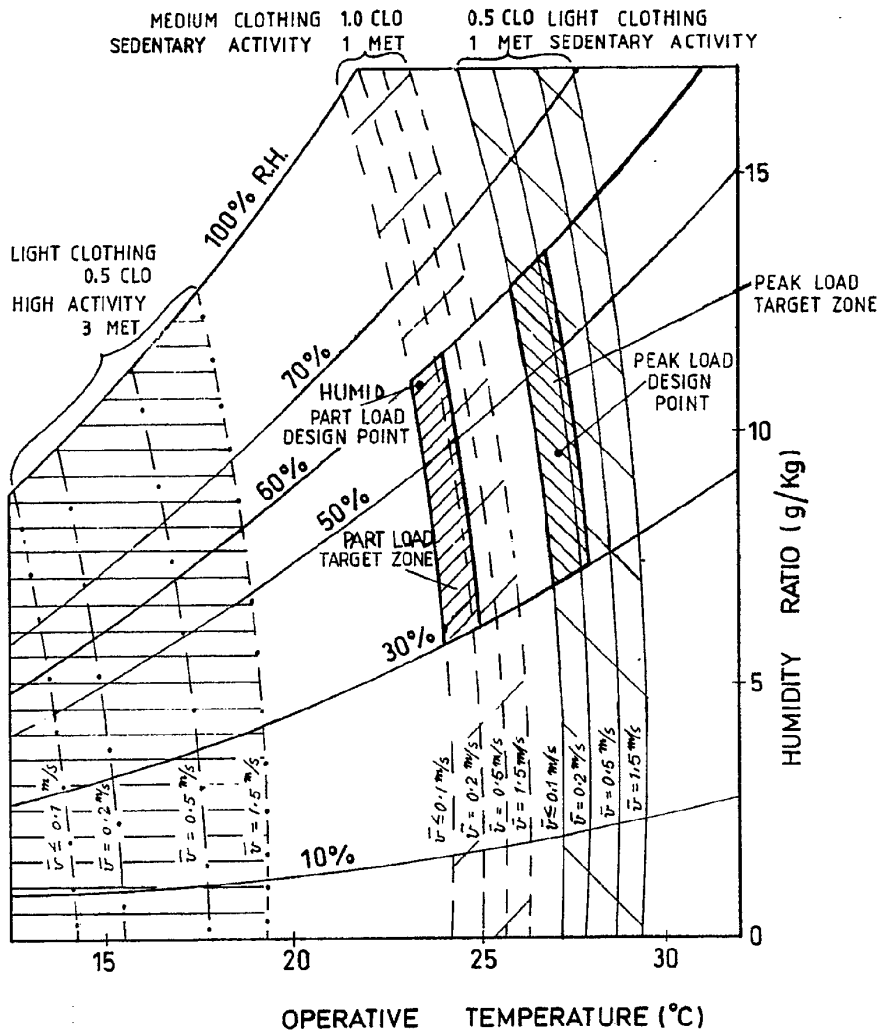

FIG 2

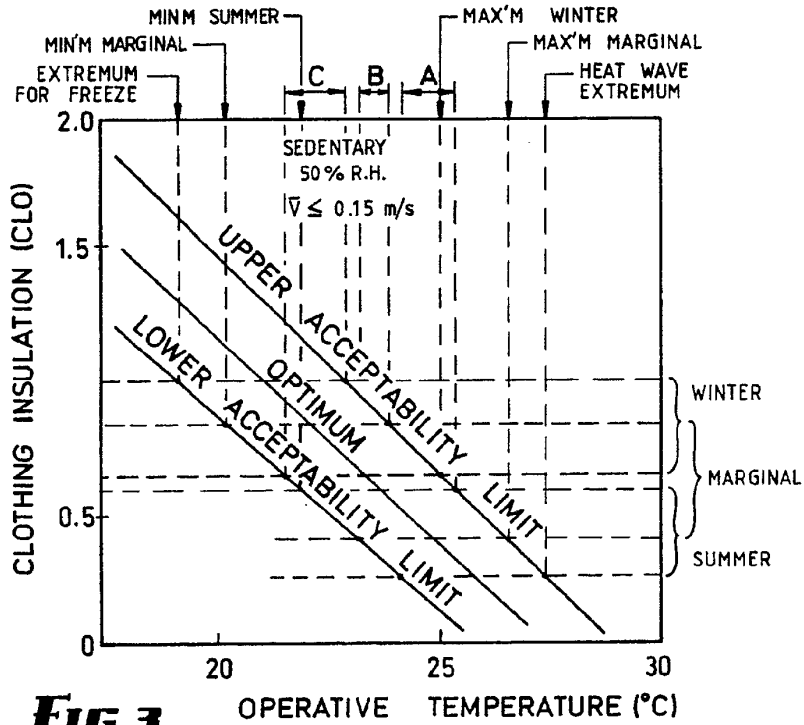

FIG 3 OPERATIVE TEMPERATURE (°C)

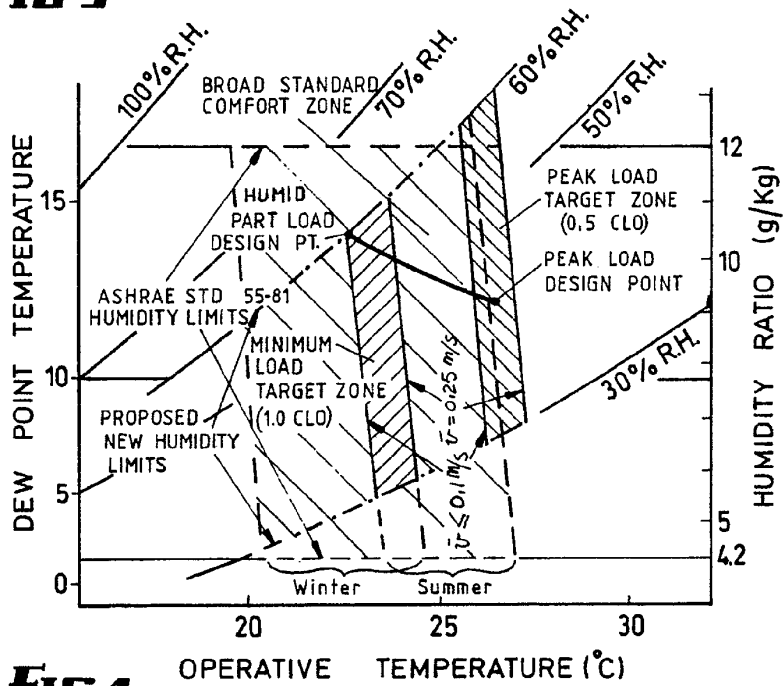

FIG 4 OPERATIVE TEMPERATURE (°C)

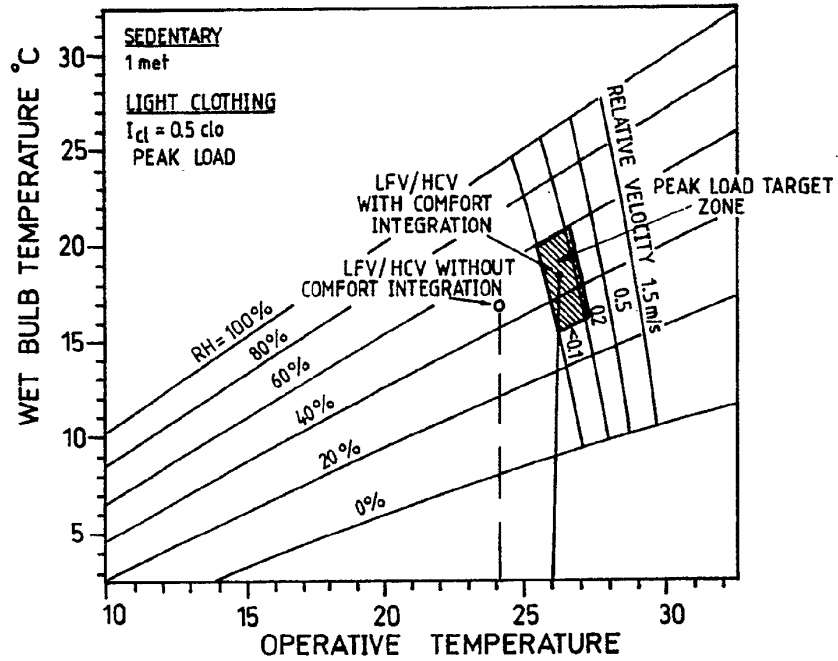

FIG 5a

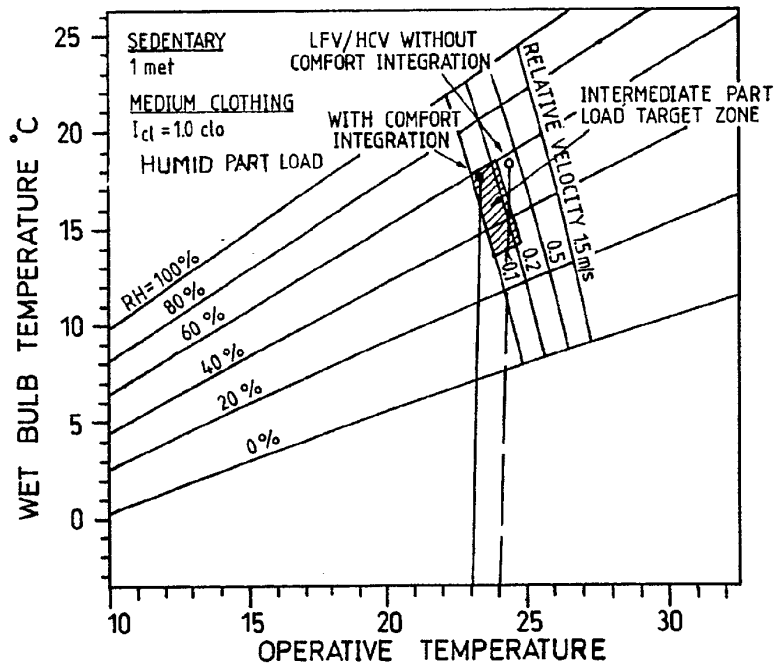

FIG 5b

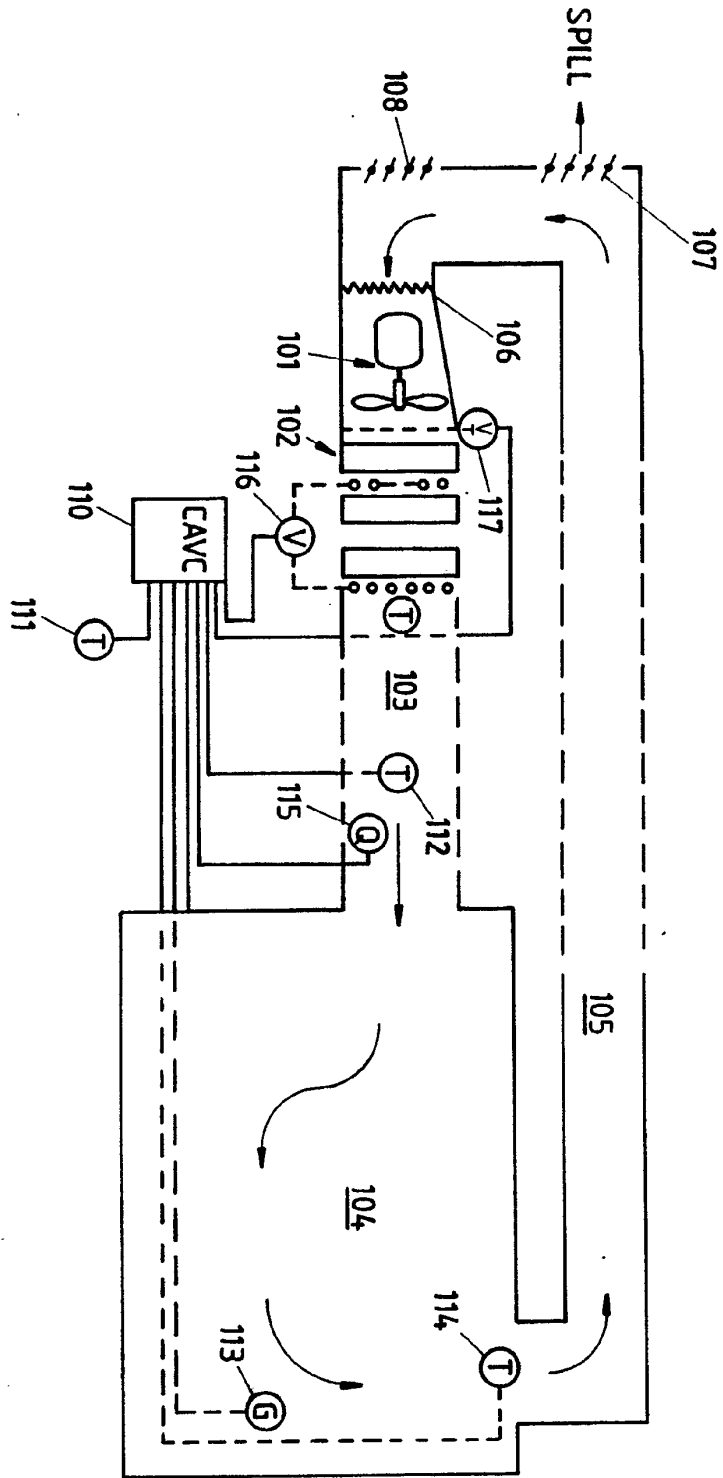

FIG 5a

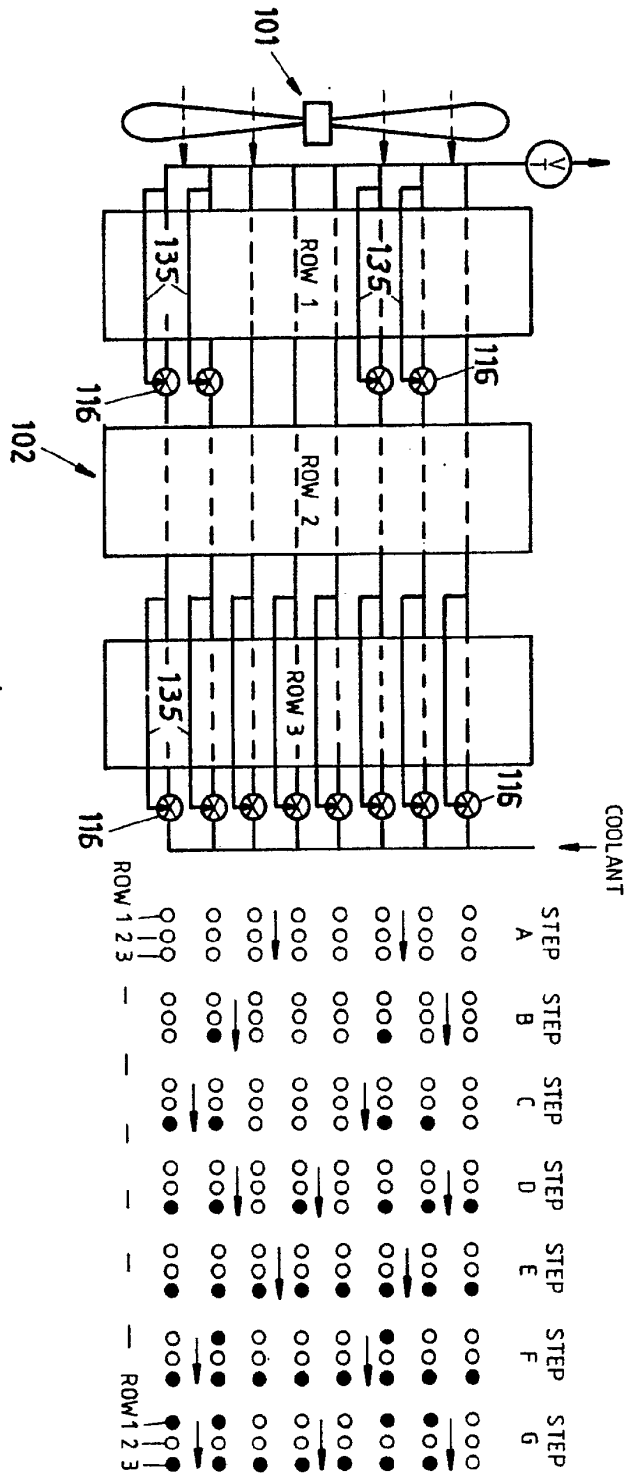

FIG 1

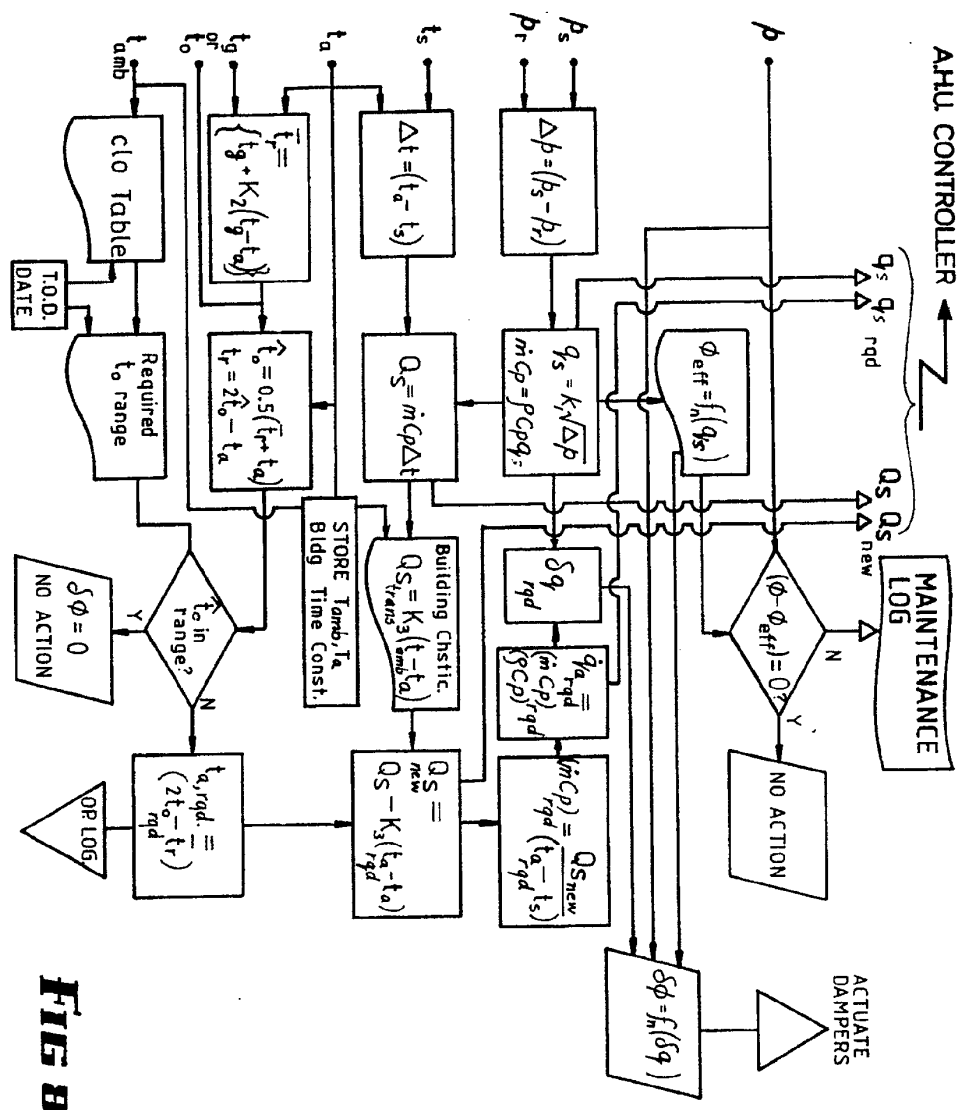

FIG B

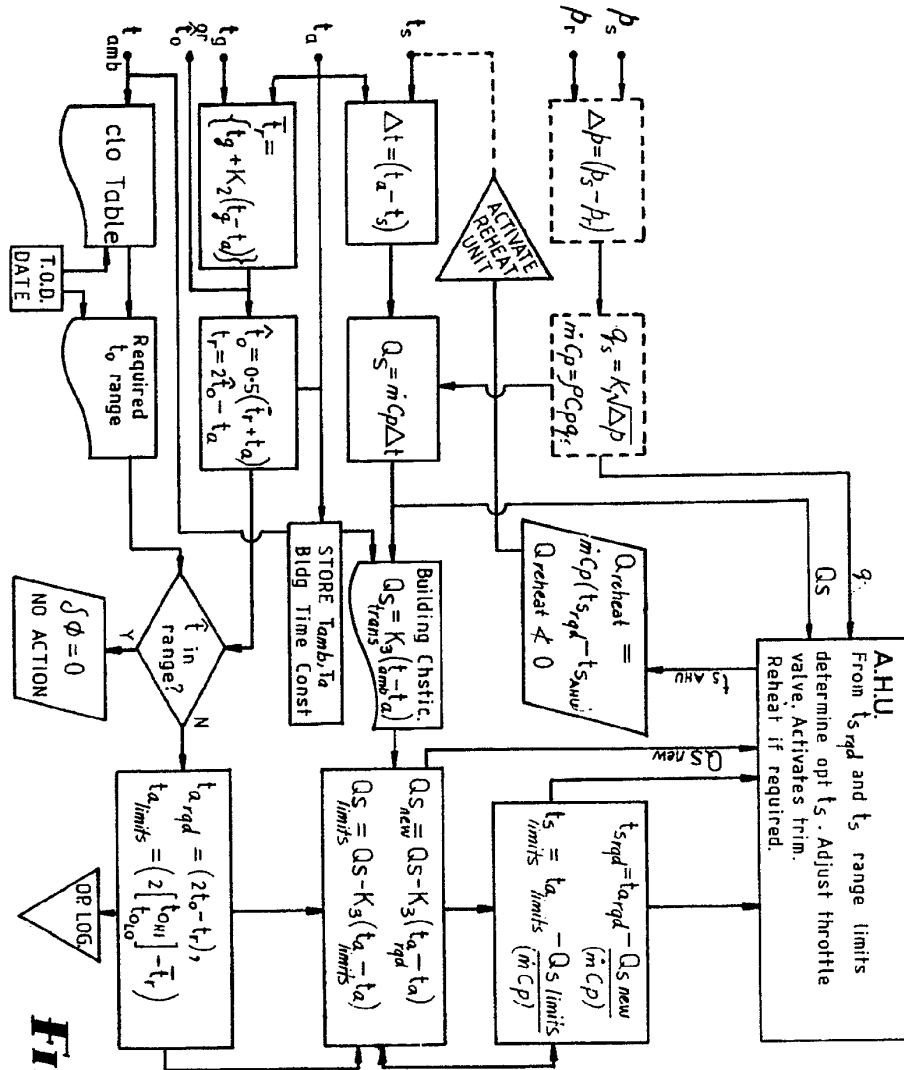

FIG 9

[Patent](#) | [Design](#) | [Trademark](#) | [KPA](#) | [K2E-PAT](#) | [Search Guide](#) | [Other Service](#) | [Reference](#) | [CONTACT US](#)

General Search Advanced Search

Util Model Pub. 486,027

Eng-Kor Patent Utility model Status:

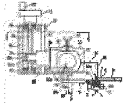
Simple	Abstract	Drawing	All drawings	Group	(1 - 1 of 1)	ALL : 3,042,201case	Application No.	
No.	Drawing	Application No.	Status	Title of Invention	IPC	Applicant	Registration No.	Full Doc
1		1019940011902	Expired	분당하중측장장치	H01L 21/60	KABUSHI KI KAISHA SHINKAW A	1001394190000	



KIPRIS
[About KIPRIS](#)
[News](#)
[Live Poll](#)
[Location & Map](#)

Related Sites
[Patent Search Websites](#)
[IP Related Organizations in Korea](#)
[Other IPOs](#)

Sitemap
[Terms of Use](#)

Contact
 Government Complex-Daejeon Building 4,
 189, Cheongsu-ro, Seo-gu, Daejeon,
 302-701 Republic of Korea
 Copyright (C) 1996-2009 Korean Intellectual
 Property Office.
 All Rights Reserved.

(19) 대한민국특허청(KR)
(12) 등록특허공보(B1)

(51) Int. Cl. ⁶ H01L 21/00	(11) 등록번호 특0139419
(21) 출원번호 특1994-011902	(24) 등록일자 1998년03월02일
(22) 출원일자 1994년05월30일	(65) 공개번호 특1995-004368
(30) 우선권주장 93-202485 1993년07월26일 일본(JP)	(43) 공개일자 1995년02월17일

(73) 특허권자	가부시킴가이샤 신가와 아라이 가즈오
(72) 발명자	일본국 도쿄도 무사시무라야마시 이나다이라 2초메 51반지노 1 다카하시 이와오
(74) 대리인	일본국 도쿄도 무사시무라야마시 이나다이라 2초메 51반지노 1 가부시킴가이샤 신가와 내 장홍식, 정진상

심사관 : 김용정

(54) 본딩하중 측정장치

요약

측정치의 신뢰성 향상 및 본딩하중의 설정시간의 단축을 도모한다.

틀체에 회전이 자유로이 지지된 나사축(18)과, 나사축(18)을 손으로 돌리는 수동핸들(23)과, 나사축(18)의 회전에 의하여 상하이동되는 암나사(24)와, 암나사(24)와 같이 상하이동하는 슬라이더(25)와, 슬라이더(25)에 고정된 게이지홀더(30)와 게이지홀더(30)에 착탈이 자유로이 부착된 텐션게이지(31)와, 텐션게이지(31)의 측정레버(34)에 고정되고, 본딩아암(5)의 캐필러리 고정나사(7)에 걸어맞춤하는 훅(35)와, 틀체를 와이어 본딩장치에 고정하는 고정클릭 및 가동클릭(43)을 구비하고 있다.

대표도

도1

명세서

[발명의 명칭]

본딩하중 측정장치

[도면의 간단한 설명]

제 1도는 본 발명으로 이루어지는 본딩하중 측정장치의 1실시예를 도시하는 부분 절단 단면 정면도,

제 2도는 좌측면도,

제 3도는 제 1도의 A-A선단면도,

제 4도는 종래의 본딩하중 측정방법의 정면도.

*도면의 주요부분에 대한 부호의 설명

5 : 본딩아암	6 : 캐필러리
7 : 캐필러리 고정나사	8 : 누름덮개 부착지주
15 : 베이스판	16 : 측판
17 : 지지판	18 : 나사축
23 : 수동핸들	24 : 암나사
25 : 슬라이더	30 : 게이지홀더
31 : 텐션게이지	34 : 측정레버
35 : 훅	41 : 고정클릭
43 : 가동클릭	

[발명의 상세한 설명]

[산업상의 이용분야]

본 발명은 와이어 본딩장치의 본딩하중 측정장치에 관한 것이다.

[종래의 기술]

와이어 본딩장치는 주지하는 바와 같이 본딩아암의 선단에 고정된 캐필러리(capillary)에 끼워통하는 와이어를 반도체 펠릿의 전극 및 외부리드의 리드에 눌러붙여 본딩하고, 전극과 리드와의 사이를 와이어로 접속하는 것이다. 이 경우 캐필러리와 와이어를 전극 및 리드에 눌러붙이는 본딩하중은 본딩 품질에 미치는 영향이 크므로, 본딩하중을 측정하고, 미리 결정된 설정치로 설정할 필요가 있다.

종래, 본딩하중의 측정은 제 4도에 도시하는 바와 같이하여 행하고 있다. 즉, 한 끝에 고리(50a)를 형성한 와이어(50)의 다른끝을 텐션게이지(31)의 측정레버(34)에 고정한다. 여기서, 본딩아암(5)에 캐필러리(6)를 고정하는 캐필러리 고정나사(7)에 와이어(50)의 고리(50a)를 건다.

그리고, 텐션게이지(31)을 손으로 쥐고, 수직으로 끌어올려 본딩하중치를 텐션게이지(31)의 눈금으로 독해한다.

독해치가 설정치와 다른 경우는, 본딩아암(5)에 하중을 가하는 리니어모우터의 전압을 높이거나, 낮추거나 하여 본딩하중을 조정한다. 상기 조작을 재차 반복하여 본딩하중치를 설정치로 한다.

[발명이 해결하려고 하는 과제]

상기 종래기술은 텐션게이지(31)를 손으로 본딩하중을 측정하기 때문에, 습관, 측정자간의 오차가 있고, 측정치의 신뢰도가 낮다. 또 일정의 측정치를 얻을 수 없기 때문에, 설정치로 조정하기 위하여 장시간을 소요한다는 문제가 있었다.

본 발명의 목적은 측정치의 신뢰성의 향상 및 본딩하중의 설정시간의 단축이 도모되는 본딩하중 측정장치를 제공하는 것에 있다.

[과제를 해결하기 위한 수단]

상기 목적을 달성하기 위한 본 발명의 구성은 틀체에 회전이 자유로이 지지된 나사축과 이 나사축을 손으로 회전하는 수동부재와, 상기 나사축에 나사맞춤하고 그 나사축의 회전에 의하여 상하로 움직이게되는 암나사와, 이 암나사와 같이 상하로 움직이는 슬라이더와, 이 슬라이더에 고정된 게이지 홀더와, 이 게이지 홀더에 착탈이 자유로이 고정된 텐션게이지와, 이 텐션게이지의 측정레버에 고정되고, 본딩아암 또는 본딩아암과 일체의 부재에 걸어맞춤하는 걸어맞춤부를 갖는 축과, 상기 틀체를 와이어 본딩장치에 고정하는 고정수단을 구비한 것을 특징으로 한다.

[작용]

고정수단에 의하여 틀체를 와이어 본딩장치에 고정한다.

그리고, 텐션게이지의 측정레버에 고정된 축의 걸어맞춤부를 본딩아암 또는 본딩아암과 일체의 부재에 걸어맞춤시킨다. 다음에 축이 상승하는 방향으로 수동부재를 회전한다. 이로서, 나사축이 회전하여 암나사, 슬라이더, 게이지 홀더 및 텐션게이지가 상승하여, 축에 의하여 본딩아암이 들어 올려진다. 그 결과, 본딩하중치가 텐션게이지에 표시된다. 여기서 텐션게이지의 표시치가 설정치에 맞도록 본딩아암에 하중을 가하는 리니어 모우터의 전압을 변화시킨다.

[실시예]

이하, 본 발명의 실시예를 제 1도 내지 제 3도에 의하여 설명한다. 우선, 와이어 본딩장치의 본 실시예에 관계하는 부분의 개략 구성을 설명한다. 제 1도에 도시하는 바와 같이, 리드프레임(1)의 양측을 가이드하는 가이드레일(2, 3) 사이에는, 리드프레임(1)을 가열하는 히트블록(4)이 상하 이동 가능하게 설치되어 있다. 가이드레일(3)의 상방에는 본딩아암(5)이 배설되어 있고, 본딩아암(5)의 한끝에는 히트블록(4)의 상방에 위치하도록 캐필러리(6)가 캐필러리고정나사(7)로 고정되어 있다. 또 가이드레일(2)의 옆에는 누름덮개고정지주(8)가 설치되어 있고, 누름덮개 고정지주(8)의 상면에는 프레임 누름덮개(9)가 고정되어 있다. 프레임 누름덮개(9)는 리드프레임(1)의 상면을 위치결정하는 누름부(9a)와, 캐필러리(6)가 임하는 본딩창(9b)이 형성되어 있다.

다음에 본딩하중 측정장치의 구성을 제 1도 내지 제 3도에 의하여 설명한다. 베이스판(15)에는 측판(16)이 고정되고, 측판(16)의 상부에는 지지판(17)이 베이스판(15)와 평행으로 고정되고, 베이스판(15), 측판(16) 및 지지판(17)으로 본딩하중 측정장치의 틀체를 구성하고 있다. 베이스판(15) 및 지지판(17)에는, 나사축(18)이 축받이(19, 20)를 사이에 두고 회전이 자유로이 지지되고, 또 가이드봉(21)의 상단단이 고정되어 있다.

나사축(18)의 상단부에는 회전팁(tip)(22)이 고정되고 회전팁(22)에는 수동핸들(23)이 고정되어 있다. 나사축(18)의 나사부에는 암나사(24)가 나사맞춤되어 있고, 암나사(24)의 양측면에는 평탄한 노치홈(24a)이 형성되어 있다. 상기 가이드봉(21)에는 슬라이더(25)가 상하이동이 자유로이 끼워넣어져 있고, 슬라이더(25)의 한끝에는 상기 암나사(24)의 노치홈(24a)에 삽입되는 암나사 홀더부(25a)가 형성되어 있다.

슬라이더(25)의 다른끝에는 게이지 홀더(30)가 고정되어 있다. 게이지홀더(30)에는 텐션게이지(31)를 게이지홀더(30)의 밑판(30a)에 눌러붙이는 판스프링(32)의 일단부가 고정되고, 또 판스프링(32)을 텐션게이지(31)에 눌러붙이는 나사부재(33)가 고정되어 있다. 텐션게이지(31)의 측정레버(34)에는 축(35)의 상단단이 고정되고, 축(35)의 하단부에는, 상기 캐필러리 고정나사(7)에 삽입되는 구멍(35a)이 형성되어 있다.

상기 베이스판(15)의 상기 측판(16)과 반대측은, 상기 게이지홀더(30)가 상하이동할 수 있도록 두갈래 형성되어 되어 있고, 베이스판(15)의 두갈래 형상부의 하면에는 상기 누름덮개고정지주(8)에 얹어 놓인 얹어놓임판(40)이 고정되어 있다. 또 베이스판(15)의 두갈래 형상 부분의 한쪽의 측면에는, 누름덮개 고정지주(8)의 돌기부(8a)의 하면에 걸어맞춤하는 고정클릭(41)이 고정되어 있다. 베이스판(15)의 두갈래형상 부분의 다른편의 측방에는, 핀(42)이 고정되고, 핀(42)에는 누름덮개 고정지주(8)의 돌기부(8a)의 아래면에 걸어맞춤하는 가동클릭(43)이 요동이 자유로이 고정되어 있다. 가동클릭(43)에는 가로가 긴 구멍

(43a) 이 형성되어 있고, 가로가 긴 구멍(43a)에는 베이스판(15)의 턱부(15a)에 나사맞춤된 나사부재(44)가 끼워맞춤하게 되어 있다. 또 가동클릭(43)이 개방하는 것과 같이, 베이스판(15)의 턱부(15a)와 가동클릭(43)사이에는 스프링(45)이 설치되어 있다.

다음에 작용에 대하여 설명한다. 우선 본딩하중 측정장치를 누름덮개 고정지주(8)의 돌기부(8a)에 고정한다. 이 조작은 나사부재(44)를 낮춘 상태에서 행한다. 나사부재(44)를 낮추면, 스프링(45)의 가압력으로 가동클릭(43)은 외측으로 열린상태로 된다.

여기서, 엮어놓는판(40)을 누름덮개 고정지주(8)에 엮어놓고, 고정클릭(41)이 누름덮개 고정지주(8)의 돌기부(8a)의 아래면에 걸어맞춤하도록 베이스판(15)을 가로로 비키어 맞춘다.

다음에 나사부재(44)를 단단히 죄다. 이로서 가동클릭(43)은 나사부재(44)에 의하여 눌러져서 핀(42)을 중심으로 회전운동하고, 가동클릭(43)은 누름덮개 고정지주(8)의 돌기부(8a)의 아랫면에 걸어맞춤한다. 이로서, 본딩하중 측정장치는 누름덮개 고정지주(8)에 고정된다.

다음에 축(35)의 구멍(35a)이 캐필러리 고정나사(7)에 대응하도록 수동핸들(23)을 돌린다. 즉 수동핸들(23)을 돌리면, 나사축(18)의 회전에 의하여 암나사(24), 슬라이더(25), 게이지홀더(30) 및 텐션게이지(31)가 상하이동한다. 축(35)의 구멍(35a)이 캐필러리 고정나사(7)에 대응하면, 구멍(35a)을 캐필러리 고정나사(7)에 건다. 이때 축(35)이 상승하도록 수동핸들(23)을 돌린다. 이로서, 본딩아암(5)은 들어올려지고, 본딩하중치가 텐션게이지(31)에 표시된다. 본딩하중치가 설정치에 맞도록 도시하지 않는 리니어 모터의 전압을 변화시켜 조정한다.

이와같이, 수동핸들(23)을 돌림으로써 텐션게이지(31)가 기계적수단으로 상하이동하여 측정할 수 있고, 측정치를 보면서 본딩하중이 보정될 수 있으므로, 본딩하중의 설정이 단시간에 용이하게 행해진다. 또 측정자 사이의 측정오차가 없고, 신뢰성이 향상한다.

더욱더, 상기 실시예에는 본딩하중 측정장치를 와이어 본딩장치의 누름덮개지주(8)에 고정하였지만, 특히 누름덮개지주(8)에 한정되는 것은 아니다. 예를들면 와이어 본딩장치의 전방측에 설치된 조작패널에 고정하도록 하여도 좋다. 또 본딩하중 측정장치의 고정수단으로서, 고정클릭(41)과 가동클릭(43)을 사용하여었지만, 이에 한정되는 것은 아니다. 예를들면 마르브트 등의 고정수단을 사용하여도 상관없다. 또 축(35)에 구멍(35a)을 설치하고, 구멍(35a)을 캐필러리 고정나사(7)에 걸어맞춤시켰지만, 이에 한정되는 것은 아니다. 예를들면 축(35)의 하단을 L자 형상으로 구부려서 이 구부러진 부분을 본딩아암(5)의 하면 또는 캐필러리(6)의 선단에 걸어맞춤시켜도 상관없다.

[발명의 효과]

본 발명에 의하면, 틀체에 회전이 자유로이 지지된 나사축과, 이 나사축을 손으로 돌리는 수동부재와, 상기 나사축에 나사맞춤하고 그 나사축의 회전에 의하여 상하이동되는 암나사와, 이 암나사와 같이 상하이동하는 슬라이더와, 이 슬라이더에 고정된 게이지 홀더와, 이 게이지홀더에 착탈이 자유로이 고정된 텐션넥이와, 이 텐션게이지의 측정레버에 고정되고, 본딩아암 또는 본딩아암과 일체의 부재에 걸어맞춤하는 걸어맞춤부를 갖는 축과, 상기 틀체를 와이어 본딩장치에 고정하는 고정수단을 구비한 본딩하중 측정장치를 사용하여 측정하기 때문에, 측정치의 신뢰성의 향상 및 본딩하중의 설정시간의 단축이 도모된다.

(57) 청구의 범위

청구항 1

틀체에 회전이 자유로이 지지된 나사축과, 이 나사축을 손으로 돌리는 수동부재와, 상기 나사축에 나사맞춤하고 그 나사축의 회전에 의하여 상하이동되는 암나사와, 이 암나사와 같이 상하이동하는 슬라이더와, 이 슬라이더에 고정된 게이지홀더와, 이 게이지홀더에 착탈이 자유로이 고정된 텐션게이지의 측정레버에 고정되고, 본딩아암 또는 본딩아암과 일체의 부재에 걸어맞춤하는 걸어맞춤부를 갖는 축과 상기틀체를 와이어 본딩장치에 고정하는 고정수단을 구비한 것을 특징으로하는 본딩하중 측정장치.

도면

(19) **KOREAN INTELLECTUAL PROPERTY OFFICE**

KOREAN PATENT ABSTRACTS

(11) Publication number: **1020000059532 A**

(43) Publication date: **05.10.2000**

(21) Application number: **1019990007184**

(71) Applicant: **• DONGHAE SYSTEMS
INC.**

(22) Application date: **04.03.1999**

(72) Inventor: **• KIM, DONG SIK**

(51) Int. Cl: **F04D 27/00**

(54) CONTROLLER OF OPERATION OF VENTILATION FAN

(57) Abstract:

PURPOSE: A controller of operation of a ventilation fan is provided to maintain a uniform temperature by automatically controlling a velocity of the ventilation fan according to temperature and automatically detect and determine abnormal operation by a microprocessor for preventing accidents in advance.

CONSTITUTION: A controller of operation of a ventilation fan includes a DC motor(1) of which rotation velocity varies in proportion to the power supply voltage by using a permanent magnet, a thermistor(2) for changing the voltage according to temperature, a ventilation fan velocity control part(3) for selecting modes with jumper pin(6) according to a plurality of change values stored in a microcomputer, an A/D converter for converting the voltage detected by the thermistor to digital values to input to the microcomputer, an alarm control part(8) for controlling LEDSs(9), a speaker(10), an error-in lamp(11), and an error-out lamp(12) to represent normal or abnormal temperatures by analyzing the input data from the A/D converter.

COPYRIGHT 2001 KIPO

Legal Status

No.	Receipt/Delivery No.	Receipt/Delivery Date	Document Title (KOR.)	Status (KOR.)
1	1-1-1999-0017820-64	1999.03.04	(출원서)	Acceptance (수리)

PATENT COOPERATION TREATY

From the INTERNATIONAL SEARCHING AUTHORITY

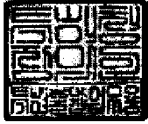
To: KING JOHN R. KNOBBE, MARTENS, OLSON & BEAR, LLP 2040 MAIN STREET, 14TH FLOOR IRVINE CA 92614 USA		<h1 style="margin: 0;">PCT</h1> <p style="margin: 0;">NOTIFICATION OF TRANSMITTAL OF THE INTERNATIONAL SEARCH REPORT AND THE WRITTEN OPINION OF THE INTERNATIONAL SEARCHING AUTHORITY, OR THE DECLARATION</p> <p style="margin: 0;">(PCT Rule 44.1)</p>
		Date of mailing <i>(day/month/year)</i> 12 DECEMBER 2011 (12.12.2011)
Applicant's or agent's file reference EFACT012WO	FOR FURTHER ACTION See paragraphs 1 and 4 below	
International application No. PCT/US2011/032537	International filing date <i>(day/month/year)</i> 14 APRIL 2011 (14.04.2011)	
Applicant ECOFACOR, INC. et al		
<p>1. <input checked="" type="checkbox"/> The applicant is hereby notified that the international search report and the written opinion of the International Searching Authority have been established and are transmitted herewith. Filing of amendments and statement under Article 19: The applicant is entitled, if he so wishes, to amend the claims of the international application (see Rule 46): When? The time limit for filing such amendments is normally two months from the date of transmittal of the international search report. Where? Directly to the International Bureau of WIPO, 34 chemin des Colombettes 1211 Geneva 20, Switzerland, Facsimile No.: +41 22 338 82 70 For more detailed instructions, see <i>PCT Applicant's Guide</i>, International Phase, paragraphs 9.004 . 9.011.</p> <p>2. <input type="checkbox"/> The applicant is hereby notified that no international search report will be established and that the declaration under Article 17(2)(a) to that effect and the written opinion of the International Searching Authority are transmitted herewith.</p> <p>3. <input type="checkbox"/> With regard to any protest against payment of (an) additional fee(s) under Rule 40.2, the applicant is notified that: <input type="checkbox"/> the protest together with the decision thereon has been transmitted to the International Bureau together with any request to forward the texts of both the protest and the decision thereon to the designated Offices. <input type="checkbox"/> no decision has been made yet on the protest; the applicant will be notified as soon as a decision is made.</p> <p>4. Reminders The applicant may submit comments on an informal basis on the written opinion of the International Searching Authority to the International Bureau. The International Bureau will send a copy of such comments to all designated Offices unless an international preliminary examination report has been or is to be established. Following the expiration of 30 months from the priority date, these comments will also be made available to the public. Shortly after the expiration of 18 months from the priority date, the international application will be published by the International Bureau. If the applicant wishes to avoid or postpone publication, a notice of withdrawal of the international application, or of the priority claim, must reach the International Bureau before the completion of the technical preparations for international publication (Rules 90bis.1 and 90bis.3). Within 19 months from the priority date, but only in respect of some designated Offices, a demand for international preliminary examination must be filed if the applicant wishes to postpone the entry into the national phase until 30 months from the priority date (in some Offices even later); otherwise, the applicant must, within 20 months from the priority date, perform the prescribed acts for entry into the national phase before those designated Offices. In respect of other designated Offices, the time limit of 30 months (or later) will apply even if no demand is filed within 19 months. For details about the applicable time limits, Office by Office, see www.wipo.int/pct/en/texts/time_limits.html and the PCT Applicant's Guide, National Chapters.</p>		
Name and mailing address of the ISA/KR  Korean Intellectual Property Office Government Complex-Daejeon, 189 Cheongsa-ro, Seo-gu, Daejeon 302-701, Republic of Korea Facsimile No. 82-42-472-7140	Authorized officer COMMISSIONER Telephone No. 82-42-481-8755	

Form PCT/ISA/220 (July 2010)

RECEIVED
IRVINE INT.

DEC 19 2011

**KNOBBE, MARTENS,
OLSON & BEAR, LLP**

* Attention

Copies of the documents cited in the international search report can be searched in the following Korean Intellectual Property Office English website for three months from the date of mailing of the international search report.

<http://www.kipo.go.kr/en/> => PCT Services => PCT Services

ID : PCT international application number
PW : 4ZMSLLZF

Inquiries related to PCT International Search Report or Written Opinion prepared by KIPO as an International Searching Authority can be answered not only by KIPO but also through IPKC (Intellectual Property Korea Center), located in Vienna, VA, which functions as a PCT Help Desk for PCT applicants.

Homepage: <http://www.ipkcenter.com>
Email: ipkc@ipkcenter.com
Phone: +1 703 388 1066
Fax: +1 703 388 1084

PATENT COOPERATION TREATY

PCT

INTERNATIONAL SEARCH REPORT

(PCT Article 18 and Rules 43 and 44)

Applicant's or agent's file reference EFACT012WO	FOR FURTHER ACTION	see Form PCT/ISA/220 as well as, where applicable, item 5 below.
International application No. PCT/US2011/032537	International filing date (<i>day/month/year</i>) 14 APRIL 2011 (14.04.2011)	(Earliest) Priority Date (<i>day/month/year</i>) 26 MAY 2010 (26.05.2010)
Applicant ECOFACOR, INC. et al		

This International search report has been prepared by this International Searching Authority and is transmitted to the applicant according to Article 18. A copy is being transmitted to the International Bureau.

This international search report consists of a total of 4 sheets.

It is also accompanied by a copy of each prior art document cited in this report.

1. Basis of the report

a. With regard to the language, the international search was carried out on the basis of:

- the international application in the language in which it was filed
 a translation of the international application into _____, which is the language of a translation furnished for the purposes of international search (Rules 12.3(a) and 23.1(b))

b. This international search report has been established taking into account the rectification of an obvious mistake authorized by or notified to this Authority under Rule 91 (Rule 43.6bis(a)).

c. With regard to any nucleotide and/or amino acid sequence disclosed in the international application, see Box No. I.

2. Certain claims were found unsearchable (See Box No. II)

3. Unity of invention is lacking (See Box No. III)

4. With regard to the title,

- the text is approved as submitted by the applicant.
 the text has been established by this Authority to read as follows:

5. With regard to the abstract,

- the text is approved as submitted by the applicant.
 the text has been established, according to Rule 38.2, by this Authority as it appears in Box No. IV. The applicant may, within one month from the date of mailing of this international search report, submit comments to this Authority.

6. With regard to the drawings,

- a. the figure of the drawings to be published with the abstract is Figure No. 7
 as suggested by the applicant.
 as selected by this Authority, because the applicant failed to suggest a figure.
 as selected by this Authority, because this figure better characterizes the invention.
- b. none of the figure is to be published with the abstract.

INTERNATIONAL SEARCH REPORT

International application No.
PCT/US2011/032537

A. CLASSIFICATION OF SUBJECT MATTER

F24F 11/02(2006.01)i, H04Q 9/04(2006.01)i

According to International Patent Classification (IPC) or to both national classification and IPC

B. FIELDS SEARCHED

Minimum documentation searched (classification system followed by classification symbols)
F24F 11/02; G06F 17/00; G05D 23/00; F25B 9/00

Documentation searched other than minimum documentation to the extent that such documents are included in the fields searched
Korean utility models and applications for utility models
Japanese utility models and applications for utility models

Electronic data base consulted during the international search (name of data base and, where practicable, search terms used)
eKOMPASS(KIPO internal) & Keywords: mobile, geographic, location, temperature



C. DOCUMENTS CONSIDERED TO BE RELEVANT

Category*	Citation of document, with indication, where appropriate, of the relevant passages	Relevant to claim No.
A	US 2006-0214014 A1 (CULLEN BASH et al.) 28 September 2006 See Abstract	1-22
A	US 2004-0176880 A1 (MICHAEL L. OBRADOVICH et al.) 09 September 2004 See Column 124-126	1-22

Further documents are listed in the continuation of Box C. See patent family annex.

* Special categories of cited documents:	"T" later document published after the international filing date or priority date and not in conflict with the application but cited to understand the principle or theory underlying the invention
"A" document defining the general state of the art which is not considered to be of particular relevance	"X" document of particular relevance; the claimed invention cannot be considered novel or cannot be considered to involve an inventive step when the document is taken alone
"E" earlier application or patent but published on or after the international filing date	"Y" document of particular relevance; the claimed invention cannot be considered to involve an inventive step when the document is combined with one or more other such documents, such combination being obvious to a person skilled in the art
"L" document which may throw doubts on priority claim(s) or which is cited to establish the publication date of citation or other special reason (as specified)	"&" document member of the same patent family
"O" document referring to an oral disclosure, use, exhibition or other means	
"P" document published prior to the international filing date but later than the priority date claimed	

Date of the actual completion of the international search 12 DECEMBER 2011 (12.12.2011)	Date of mailing of the international search report 12 DECEMBER 2011 (12.12.2011)
--	--

Name and mailing address of the ISA/KR  Korean Intellectual Property Office Government Complex-Daejeon, 189 Cheongsu-ro, Seo-gu, Daejeon 302-701, Republic of Korea Facsimile No. 82-42-472-7140	Authorized officer JANG, GI JEONG Telephone No. 82-42-481-5498 
---	---

INTERNATIONAL SEARCH REPORT

Information on patent family members

International application No.

PCT/US2011/032537

Patent document cited in search report	Publication date	Patent family member(s)	Publication date
US 2006-0214014 A1	28.09.2006	US 7640760 B2	05.01.2010
US 2004-0176880 A1	09.09.2004	AT 356734 T	15.04.2007
		AT 399110 T	15.07.2008
		AU 6245398 A	26.08.1998
		AU 6245398 A	26.08.1998
		CA 2283843 A1	13.08.1998
		CA 2283843 C	20.11.2007
		CA 2596489 A1	13.08.1998
		DE 69837318 D1	16.10.2008
		EP 0956219 A2	17.11.1999
		EP 0956219 A2	30.10.2002
		EP 0956219 A4	24.01.2001
		EP 0956219 B1	25.06.2008
		JP 2002-505631 A	19.02.2002
		JP 2002-505631 T	19.02.2002
		JP 2002-505631 T	19.02.2002
		US 06009355A A	28.12.1999
		US 06131060A A	10.10.2000
		US 2001-0020202 A1	06.09.2001
		US 2001-0021887 A1	13.09.2001
		US 2001-0029410 A1	11.10.2001
		US 2001-0038414 A1	08.11.2001
		US 2002-0065585 A1	30.05.2002
		US 2002-0082751 A1	27.06.2002
		US 2002-0082752 A1	27.06.2002
		US 2002-0156555 A1	24.10.2002
		US 2002-0198635 A1	26.12.2002
		US 2003-0004616 A1	02.01.2003
		US 2004-0162645 A1	19.08.2004
		US 2004-0162646 A1	19.08.2004
		US 2005-0165513 A1	28.07.2005
		US 2005-0203674 A1	15.09.2005
		US 2006-0200285 A1	07.09.2006
		US 2010-0175014 A1	08.07.2010
		US 6175782 B1	16.01.2001
		US 6233506 B1	15.05.2001
		US 6282464 B1	28.08.2001
		US 6330497 B1	11.12.2001
		US 6438465 B2	20.08.2002
		US 6449535 B1	10.09.2002
		US 6459961 B1	01.10.2002
		US 6542794 B2	01.04.2003
		US 6542795 B2	01.04.2003
		US 6577928 B2	10.06.2003
		US 6587758 B2	01.07.2003
		US 6587759 B2	01.07.2003
		US 6859687 B2	22.02.2005
		US 6922616 B2	26.07.2005

Form PCT/ISA/210 (patent family annex) (July 2009)

INTERNATIONAL SEARCH REPORT

Information on patent family members

International application No.

PCT/US2011/032537

Patent document cited in search report	Publication date	Patent family member(s)	Publication date
		US 7062362 B2	13.06.2006
		US 7124004 B2	17.10.2006
		US 7171291 B2	30.01.2007
		US 7499778 B2	03.03.2009
		WO 98-34812 A2	13.08.1998
		WO 98-34812A2	13.08.1998
		WO 98-34812A3	05.11.1998
		WO 98-34812A3	05.11.1998

Form PCT/ISA/210 (patent family annex) (July 2009)

PATENT COOPERATION TREATY

From the
INTERNATIONAL SEARCHING AUTHORITY

To:
KING JOHN R.

KNOBBE, MARTENS, OLSON & BEAR, LLP 2040 MAIN STREET, 14TH FLOOR IRVINE CA 92614 USA

PCT
WRITTEN OPINION OF THE
INTERNATIONAL SEARCHING AUTHORITY
(PCT Rule 43bis.1)

Date of mailing
(day/month/year) **12 DECEMBER 2011 (12.12.2011)**

Applicant's or agent's file reference
EFACT012WO

FOR FURTHER ACTION
See paragraph 2 below

International application No.
PCT/US2011/032537

International filing date (day/month/year)
14 APRIL 2011 (14.04.2011)

Priority date(day/month/year)
26 MAY 2010 (26.05.2010)

International Patent Classification (IPC) or both national classification and IPC

F24F 11/02(2006.01), H04Q 9/04(2006.01)

Applicant

ECOFACOR, INC. et al



1. This opinion contains indications relating to the following items:

- Box No. I Basis of the opinion
- Box No. II Priority
- Box No. III Non-establishment of opinion with regard to novelty, inventive step and industrial applicability
- Box No. IV Lack of unity of invention
- Box No. V Reasoned statement under Rule 43bis.1(a)(i) with regard to novelty, inventive step or industrial applicability; citations and explanations supporting such statement
- Box No. VI Certain documents cited
- Box No. VII Certain defects in the international application
- Box No. VIII Certain observations on the international application

2. FURTHER ACTION

If a demand for international preliminary examination is made, this opinion will be considered to be a written opinion of the International Preliminary Examining Authority ("IPEA") except that this does not apply where the applicant chooses an Authority other than this one to be the IPEA and the chosen IPEA has notified the International Bureau under Rule 66.1bis(b) that written opinions of this International Searching Authority will not be so considered.

If this opinion is, as provided above, considered to be a written opinion of the IPEA, the applicant is invited to submit to the IPEA a written reply together, where appropriate, with amendments, before the expiration of 3 months from the date of mailing of Form PCT/ISA/220 or before the expiration of 22 months from the priority date, whichever expires later.
For further options, see Form PCT/ISA/220.

 <p>Name and mailing address of the ISA/KR Korean Intellectual Property Office Government Complex-Daejeon, 189 Cheongsu-ro, Seo-gu, Daejeon 302- 701, Republic of Korea Facsimile No. 82-42-472-7140</p>	<p>Date of completion of this opinion 12 DECEMBER 2011 (12.12.2011)</p>	<p>Authorized officer JANG, GI JEONG Telephone No.82-42-481-5498</p> 
---	---	---

WRITTEN OPINION OF THE
INTERNATIONAL SEARCHING AUTHORITY

International application No.

PCT/US2011/032537

Box No. 1 Basis of this opinion

1. With regard to the language, this opinion has been established on the basis of:
 - the international application in the language in which it was filed
 - a translation of the international application into _____, which is the language of a translation furnished for the purposes of international search (Rules 12.3(a) and 23.1(b))
2. This opinion has been established taking into account the rectification of an obvious mistake authorized by or notified to this Authority under Rule 91 (Rule 43bis.1(a))
3. With regard to any nucleotide and/or amino acid sequence disclosed in the international application, this opinion has been established on the basis of:
 - a. a sequence listing filed or furnished
 - on paper
 - in electronic form
 - b. time of filing or furnishing
 - contained in the international application as filed.
 - filed together with the international application in electronic form.
 - furnished subsequently to this Authority for the purposes of search.
4. In addition, in the case that more than one version or copy of a sequence listing has been filed or furnished, the required statements that the information in the subsequent or additional copies is identical to that in the application as filed or does not go beyond the application as filed, as appropriate, were furnished.
5. Additional comments:

WRITTEN OPINION OF THE
INTERNATIONAL SEARCHING AUTHORITY

International application No.
PCT/US2011/032537

Box No. V Reasoned statement under Rule 43bis.1(a)(i) with regard to novelty, inventive step or industrial applicability; citations and explanations supporting such statement

1. Statement

Novelty (N)	Claims	1-22	YES
	Claims	NONE	NO
Inventive step (IS)	Claims	1-22	YES
	Claims	NONE	NO
Industrial applicability (IA)	Claims	1-22	YES
	Claims	NONE	NO

2. Citations and explanations :

Reference is made to the following documents:

D1: US 2006-0214014 A1 (CULLEN BASH et al.) 28 September 2006
D2: US 2004-0176886 A1 (MICHAEL L. OBRADOVICH et al.) 09 September 2004

1. Novelty and Inventive step

1.1 Claims 1 and 12

The subject matter of claims 1 and 12 differs from the prior art documents of D1-D2 in that the prior art documents do not disclose a adjusting temperature setpoint comprising a mobile location and climate control devices. And it is not obvious to a person skilled in the art by the documents, taken alone or in combination.

Therefore, the subject matter of claims 1 and 12 meets the requirements of PCT Article 33(2) and (3) with respect to novelty and inventive step.

1.2 Claims 2-11 and 13-22

Claims 2-11 and 13-22 are dependent on 1 and 12.

Therefore, the subject matter of claims 2-11 and 13-22 meets the requirements of PCT Article 33(2) and (3) with respect to novelty and inventive step automatically.

2. Industrial Applicability

The subject matter of claims 1-22 is industrially applicable under PCT Article 33(4).

Under the Paperwork Reduction Act of 1995, no persons are required to respond to a collection of information unless it displays a valid OMB control number.

PATENT APPLICATION FEE DETERMINATION RECORD Substitute for Form PTO-875				Application or Docket Number 12/778,052		Filing Date 05/11/2010		<input type="checkbox"/> To be Mailed				
APPLICATION AS FILED – PART I												
(Column 1)			(Column 2)			SMALL ENTITY <input checked="" type="checkbox"/>		OR		OTHER THAN SMALL ENTITY		
FOR		NUMBER FILED	NUMBER EXTRA		RATE (\$)	FEE (\$)	OR		RATE (\$)	FEE (\$)		
<input type="checkbox"/> BASIC FEE <small>(37 CFR 1.16(a), (b), or (c))</small>		N/A	N/A		N/A				N/A			
<input type="checkbox"/> SEARCH FEE <small>(37 CFR 1.16(k), (i), or (m))</small>		N/A	N/A		N/A		N/A					
<input type="checkbox"/> EXAMINATION FEE <small>(37 CFR 1.16(o), (p), or (q))</small>		N/A	N/A		N/A		N/A					
TOTAL CLAIMS <small>(37 CFR 1.16(j))</small>		minus 20 = *			X \$ =		OR		X \$ =			
INDEPENDENT CLAIMS <small>(37 CFR 1.16(h))</small>		minus 3 = *			X \$ =				X \$ =			
<input type="checkbox"/> APPLICATION SIZE FEE <small>(37 CFR 1.16(s))</small>		If the specification and drawings exceed 100 sheets of paper, the application size fee due is \$250 (\$125 for small entity) for each additional 50 sheets or fraction thereof. See 35 U.S.C. 41(a)(1)(G) and 37 CFR 1.16(s).										
<input type="checkbox"/> MULTIPLE DEPENDENT CLAIM PRESENT <small>(37 CFR 1.16(j))</small>												
* If the difference in column 1 is less than zero, enter "0" in column 2.												
APPLICATION AS AMENDED – PART II												
(Column 1)			(Column 2)		(Column 3)		SMALL ENTITY		OR		OTHER THAN SMALL ENTITY	
AMENDMENT	02/27/2013		CLAIMS REMAINING AFTER AMENDMENT		HIGHEST NUMBER PREVIOUSLY PAID FOR	PRESENT EXTRA	RATE (\$)	ADDITIONAL FEE (\$)	OR		RATE (\$)	ADDITIONAL FEE (\$)
	Total <small>(37 CFR 1.16(i))</small>		* 23	Minus	** 23	= 0	X \$31 =	0			X \$ =	
	Independent <small>(37 CFR 1.16(h))</small>		* 3	Minus	***3	= 0	X \$125 =	0	X \$ =			
	<input type="checkbox"/> Application Size Fee <small>(37 CFR 1.16(s))</small>											
	<input type="checkbox"/> FIRST PRESENTATION OF MULTIPLE DEPENDENT CLAIM <small>(37 CFR 1.16(j))</small>											
TOTAL ADD'L FEE							0		OR		TOTAL ADD'L FEE	
AMENDMENT			CLAIMS REMAINING AFTER AMENDMENT		HIGHEST NUMBER PREVIOUSLY PAID FOR	PRESENT EXTRA	RATE (\$)	ADDITIONAL FEE (\$)	OR		RATE (\$)	ADDITIONAL FEE (\$)
	Total <small>(37 CFR 1.16(i))</small>		*	Minus	**	=	X \$ =				X \$ =	
	Independent <small>(37 CFR 1.16(h))</small>		*	Minus	***	=	X \$ =		X \$ =			
	<input type="checkbox"/> Application Size Fee <small>(37 CFR 1.16(s))</small>											
	<input type="checkbox"/> FIRST PRESENTATION OF MULTIPLE DEPENDENT CLAIM <small>(37 CFR 1.16(j))</small>											
TOTAL ADD'L FEE									OR		TOTAL ADD'L FEE	
* If the entry in column 1 is less than the entry in column 2, write "0" in column 3.												
** If the "Highest Number Previously Paid For" IN THIS SPACE is less than 20, enter "20".												
*** If the "Highest Number Previously Paid For" IN THIS SPACE is less than 3, enter "3".												
The "Highest Number Previously Paid For" (Total or Independent) is the highest number found in the appropriate box in column 1.												

Legal Instrument Examiner:
/LINDA HUMES/

This collection of information is required by 37 CFR 1.16. The information is required to obtain or retain a benefit by the public which is to file (and by the USPTO to process) an application. Confidentiality is governed by 35 U.S.C. 122 and 37 CFR 1.14. This collection is estimated to take 12 minutes to complete, including gathering, preparing, and submitting the completed application form to the USPTO. Time will vary depending upon the individual case. Any comments on the amount of time you require to complete this form and/or suggestions for reducing this burden, should be sent to the Chief Information Officer, U.S. Patent and Trademark Office, U.S. Department of Commerce, P.O. Box 1450, Alexandria, VA 22313-1450. DO NOT SEND FEES OR COMPLETED FORMS TO THIS ADDRESS. **SEND TO: Commissioner for Patents, P.O. Box 1450, Alexandria, VA 22313-1450.**

If you need assistance in completing the form, call 1-800-PTO-9199 and select option 2.

INFORMATION DISCLOSURE STATEMENT BY APPLICANT	Application No.	12/778052
	Filing Date	05-11-2010
	First Named Inventor	Steinberg, John Douglas et al
	Art Unit	3744
<i>(Multiple sheets used when necessary)</i>		Examiner
SHEET 1 OF 1		Attorney Docket No. EFACT.007A

U.S. PATENT DOCUMENTS					
Examiner Initials	Cite No.	Document Number Number - Kind Code (if known) Example: 1,234,567 B1	Publication Date MM-DD-YYYY	Name of Patentee or Applicant	Pages, Columns, Lines Where Relevant Passages or Relevant Figures Appear
	1	5,682,949	11-04-1997	Ratcliffe et al.	
	2	5,818,347	10-06-1998	Dolan et al.	
	3	5,977,964	11-1999	Williams et al.	
	4	6,912,429	06-2005	Bilger	
	5	7,061,393	06-2006	Buckingham et al.	
	6	7,242,988	07-2007	Hoffberg et al.	
	7	7,260,823	08-2007	Schlack et al.	
	8	7,483,964	01-2009	Jackson et al.	
	9	H2176	12-2006	Meyer et al.	
	10	2006/0045105 A1	03-2006	Dobosz et al.	
	11	2007/0146126 A1	06-2007	Wang	
	12	2008/0281472 A1	11-2008	Podgorny et al.	
	13	2009/0052859 A 1	02-2009	Greenberger et al.	
	14	2010/0156608 A1	06-2010	BAE et al.	
	15	2010/0162285 A1	06-2010	Cohen et al.	

FOREIGN PATENT DOCUMENTS						
Examiner Initials	Cite No.	Foreign Patent Document Country Code-Number-Kind Code Example: JP 1234567 A1	Publication Date MM-DD-YYYY	Name of Patentee or Applicant	Pages, Columns, Lines Where Relevant Passages or Relevant Figures Appear	T ¹

NON PATENT LITERATURE DOCUMENTS			
Examiner Initials	Cite No.	Include name of the author (in CAPITAL LETTERS), title of the article (when appropriate), title of the item (book, magazine, journal, serial, symposium, catalog, etc.), date, page(s), volume-issue number(s), publisher, city and/or country where published.	T ¹
	16	Honeywell, "W7600/W7620 Controller Reference Manual, HW0021207, October, 1992	
	17	PIER, Southern California Edison, Demand Responsive Control of Air Conditioning via Programmable Communicating Thermostats Draft Report	
	18	WETTER, et al., A comparison of deterministic and probabilistic optimization algorithms for nonsmooth simulation-based optimization., Building and Environment 39, 2004, Pages 989-999	

10922450
032111

Examiner Signature	Date Considered
<p>*Examiner: Initial if reference considered, whether or not citation is in conformance with MPEP 609. Draw line through citation if not in conformance and not considered. Include copy of this form with next communication to applicant.</p>	

T¹ - Place a check mark in this area when an English language Translation is attached.

Electronic Acknowledgement Receipt

EFS ID:	9723052
Application Number:	12778052
International Application Number:	
Confirmation Number:	5650
Title of Invention:	SYSTEM, METHOD AND APPARATUS FOR IDENTIFYING MANUAL INPUTS TO AND ADAPTIVE PROGRAMMING OF A THERMOSTAT
First Named Inventor/Applicant Name:	John Douglas Steinberg
Customer Number:	20995
Filer:	John R. King/Heide Young
Filer Authorized By:	John R. King
Attorney Docket Number:	EFACT.007A
Receipt Date:	23-MAR-2011
Filing Date:	11-MAY-2010
Time Stamp:	17:00:23
Application Type:	Utility under 35 USC 111(a)

Payment information:

Submitted with Payment	no
------------------------	----

File Listing:

Document Number	Document Description	File Name	File Size(Bytes)/ Message Digest	Multi Part /.zip	Pages (if appl.)
1		EFACT-007A_ids.pdf	99340 <small>ad216ab7fdb0b51bfa8e35d15715290b9d05239d</small>	yes	2

Multipart Description/PDF files in .zip description					
Document Description			Start	End	
Transmittal Letter			1	1	
Information Disclosure Statement (IDS) Filed (SB/08)			2	2	
Warnings:					
Information:					
2	NPL Documents	EFACT-007A_REF16.pdf	1761303 fb5c90f34e552709013da2d59cb6a0b980565bb3	no	32
Warnings:					
Information:					
3	NPL Documents	EFACT-007A_REF17.pdf	8671806 9a0f58661a50532ec7e8188e0683779bb954babc	no	93
Warnings:					
Information:					
4	NPL Documents	EFACT-007A_REF18.pdf	977832 eec8948afec6510c7e85943e9fa759188be90aa1	no	11
Warnings:					
Information:					
Total Files Size (in bytes):			11510281		
<p>This Acknowledgement Receipt evidences receipt on the noted date by the USPTO of the indicated documents, characterized by the applicant, and including page counts, where applicable. It serves as evidence of receipt similar to a Post Card, as described in MPEP 503.</p> <p><u>New Applications Under 35 U.S.C. 111</u> If a new application is being filed and the application includes the necessary components for a filing date (see 37 CFR 1.53(b)-(d) and MPEP 506), a Filing Receipt (37 CFR 1.54) will be issued in due course and the date shown on this Acknowledgement Receipt will establish the filing date of the application.</p> <p><u>National Stage of an International Application under 35 U.S.C. 371</u> If a timely submission to enter the national stage of an international application is compliant with the conditions of 35 U.S.C. 371 and other applicable requirements a Form PCT/DO/EO/903 indicating acceptance of the application as a national stage submission under 35 U.S.C. 371 will be issued in addition to the Filing Receipt, in due course.</p> <p><u>New International Application Filed with the USPTO as a Receiving Office</u> If a new international application is being filed and the international application includes the necessary components for an international filing date (see PCT Article 11 and MPEP 1810), a Notification of the International Application Number and of the International Filing Date (Form PCT/RO/105) will be issued in due course, subject to prescriptions concerning national security, and the date shown on this Acknowledgement Receipt will establish the international filing date of the application.</p>					

INFORMATION DISCLOSURE STATEMENT

Applicant : Steinberg, et al.
App. No : 12/778,052
Filed : May 11, 2010
For : SYSTEM, METHOD AND APPARATUS FOR IDENTIFYING MANUAL INPUTS TO AND ADAPTIVE PROGRAMMING OF A THERMOSTAT
Examiner : Unknown
Art Unit : 3744
Conf No. : 5650

Mail Stop Amendment
Commissioner for Patents
P.O. Box 1450
Alexandria, VA 22313-1450

Dear Sir:

Enclosed for filing in the above-identified application is a PTO/SB/08 Equivalent listing eighteen (18) references, of which three (3) are enclosed/submitted.

This Information Disclosure Statement is being filed before the receipt of a first Office Action on the merits, and presumably no fee is required. If a first Office Action on the merits was mailed before the mailing date of this Statement, the Commissioner is authorized to charge the fee set forth in 37 C.F.R. § 1.17(p) to Deposit Account No. 11-1410.

Respectfully submitted,
KNOBBE, MARTENS, OLSON & BEAR, LLP

Dated: 3-23-2011

By: John R. King
John R. King
Registration No. 34,362
Attorney of Record
Customer No. 20,995
(949) 760-0404



UNITED STATES PATENT AND TRADEMARK OFFICE

UNITED STATES DEPARTMENT OF COMMERCE
United States Patent and Trademark Office
Address: COMMISSIONER FOR PATENTS
P.O. Box 1450
Alexandria, Virginia 22313-1450
www.uspto.gov

Table with 4 columns: APPLICATION NUMBER (12/778,052), FILING OR 371(C) DATE (05/11/2010), FIRST NAMED APPLICANT (John Douglas Steinberg), ATTY. DOCKET NO./TITLE (EFACT.007A)

CONFIRMATION NO. 5650

20995
KNOBBE MARTENS OLSON & BEAR LLP
2040 MAIN STREET
FOURTEENTH FLOOR
IRVINE, CA 92614

PUBLICATION NOTICE



Title: SYSTEM, METHOD AND APPARATUS FOR IDENTIFYING MANUAL INPUTS TO AND ADAPTIVE PROGRAMMING OF A THERMOSTAT

Publication No. US-2010-0308119-A1

Publication Date: 12/09/2010

NOTICE OF PUBLICATION OF APPLICATION

The above-identified application will be electronically published as a patent application publication pursuant to 37 CFR 1.211, et seq. The patent application publication number and publication date are set forth above.

The publication may be accessed through the USPTO's publicly available Searchable Databases via the Internet at www.uspto.gov. The direct link to access the publication is currently http://www.uspto.gov/patft/.

The publication process established by the Office does not provide for mailing a copy of the publication to applicant. A copy of the publication may be obtained from the Office upon payment of the appropriate fee set forth in 37 CFR 1.19(a)(1). Orders for copies of patent application publications are handled by the USPTO's Office of Public Records. The Office of Public Records can be reached by telephone at (703) 308-9726 or (800) 972-6382, by facsimile at (703) 305-8759, by mail addressed to the United States Patent and Trademark Office, Office of Public Records, Alexandria, VA 22313-1450 or via the Internet.

In addition, information on the status of the application, including the mailing date of Office actions and the dates of receipt of correspondence filed in the Office, may also be accessed via the Internet through the Patent Electronic Business Center at www.uspto.gov using the public side of the Patent Application Information and Retrieval (PAIR) system. The direct link to access this status information is currently http://pair.uspto.gov/. Prior to publication, such status information is confidential and may only be obtained by applicant using the private side of PAIR.

Further assistance in electronically accessing the publication, or about PAIR, is available by calling the Patent Electronic Business Center at 1-866-217-9197.

Office of Data Management, Application Assistance Unit (571) 272-4000, or (571) 272-4200, or 1-888-786-0101



UNITED STATES PATENT AND TRADEMARK OFFICE

UNITED STATES DEPARTMENT OF COMMERCE
United States Patent and Trademark Office
Address: COMMISSIONER FOR PATENTS
P.O. Box 1450
Alexandria, Virginia 22313-1450
www.uspto.gov

APPLICATION NUMBER	FILING OR 371(C) DATE	FIRST NAMED APPLICANT	ATTY. DOCKET NO./TITLE
12/778,052	05/11/2010	John Douglas Steinberg	EFACT.007A

CONFIRMATION NO. 5650

POA ACCEPTANCE LETTER

20995
KNOBBE MARTENS OLSON & BEAR LLP
2040 MAIN STREET
FOURTEENTH FLOOR
IRVINE, CA 92614



Date Mailed: 09/02/2010

NOTICE OF ACCEPTANCE OF POWER OF ATTORNEY

This is in response to the Power of Attorney filed 08/20/2010.

The Power of Attorney in this application is accepted. Correspondence in this application will be mailed to the above address as provided by 37 CFR 1.33.

/mbeyene/

Office of Data Management, Application Assistance Unit (571) 272-4000, or (571) 272-4200, or 1-888-786-0101



UNITED STATES PATENT AND TRADEMARK OFFICE

UNITED STATES DEPARTMENT OF COMMERCE
United States Patent and Trademark Office
Address: COMMISSIONER FOR PATENTS
P.O. Box 1450
Alexandria, Virginia 22313-1450
www.uspto.gov

Table with 7 columns: APPLICATION NUMBER, FILING or 371(c) DATE, GRP ART UNIT, FIL FEE REC'D, ATTY.DOCKET.NO, TOT CLAIMS, IND CLAIMS. Row 1: 12/778,052, 05/11/2010, 3744, 605, EFACT.007A, 23, 3

CONFIRMATION NO. 5650

UPDATED FILING RECEIPT



20995
KNOBBE MARTENS OLSON & BEAR LLP
2040 MAIN STREET
FOURTEENTH FLOOR
IRVINE, CA 92614

Date Mailed: 09/02/2010

Receipt is acknowledged of this non-provisional patent application. The application will be taken up for examination in due course. Applicant will be notified as to the results of the examination. Any correspondence concerning the application must include the following identification information: the U.S. APPLICATION NUMBER, FILING DATE, NAME OF APPLICANT, and TITLE OF INVENTION. Fees transmitted by check or draft are subject to collection. Please verify the accuracy of the data presented on this receipt. If an error is noted on this Filing Receipt, please submit a written request for a Filing Receipt Correction. Please provide a copy of this Filing Receipt with the changes noted thereon. If you received a "Notice to File Missing Parts" for this application, please submit any corrections to this Filing Receipt with your reply to the Notice. When the USPTO processes the reply to the Notice, the USPTO will generate another Filing Receipt incorporating the requested corrections

Applicant(s)

John Douglas Steinberg, Millbrae, CA;
Scott Douglas Hublou, Redwood City, CA;
Leo Cheung, Sunnyvale, CA;

Assignment For Published Patent Application

ECOFACOR, INC., Millbrae, CA

Power of Attorney: The patent practitioners associated with Customer Number 20995

Domestic Priority data as claimed by applicant

This appln claims benefit of 61/215,999 05/12/2009

Foreign Applications

If Required, Foreign Filing License Granted: 05/28/2010

The country code and number of your priority application, to be used for filing abroad under the Paris Convention, is US 12/778,052

Projected Publication Date: 12/09/2010

Non-Publication Request: No

Early Publication Request: No

** SMALL ENTITY **

Title

SYSTEM, METHOD AND APPARATUS FOR IDENTIFYING MANUAL INPUTS TO AND ADAPTIVE PROGRAMMING OF A THERMOSTAT

Preliminary Class

236

PROTECTING YOUR INVENTION OUTSIDE THE UNITED STATES

Since the rights granted by a U.S. patent extend only throughout the territory of the United States and have no effect in a foreign country, an inventor who wishes patent protection in another country must apply for a patent in a specific country or in regional patent offices. Applicants may wish to consider the filing of an international application under the Patent Cooperation Treaty (PCT). An international (PCT) application generally has the same effect as a regular national patent application in each PCT-member country. The PCT process **simplifies** the filing of patent applications on the same invention in member countries, but **does not result** in a grant of "an international patent" and does not eliminate the need of applicants to file additional documents and fees in countries where patent protection is desired.

Almost every country has its own patent law, and a person desiring a patent in a particular country must make an application for patent in that country in accordance with its particular laws. Since the laws of many countries differ in various respects from the patent law of the United States, applicants are advised to seek guidance from specific foreign countries to ensure that patent rights are not lost prematurely.

Applicants also are advised that in the case of inventions made in the United States, the Director of the USPTO must issue a license before applicants can apply for a patent in a foreign country. The filing of a U.S. patent application serves as a request for a foreign filing license. The application's filing receipt contains further information and guidance as to the status of applicant's license for foreign filing.

Applicants may wish to consult the USPTO booklet, "General Information Concerning Patents" (specifically, the section entitled "Treaties and Foreign Patents") for more information on timeframes and deadlines for filing foreign patent applications. The guide is available either by contacting the USPTO Contact Center at 800-786-9199, or it can be viewed on the USPTO website at <http://www.uspto.gov/web/offices/pac/doc/general/index.html>.

For information on preventing theft of your intellectual property (patents, trademarks and copyrights), you may wish to consult the U.S. Government website, <http://www.stopfakes.gov>. Part of a Department of Commerce initiative, this website includes self-help "toolkits" giving innovators guidance on how to protect intellectual property in specific countries such as China, Korea and Mexico. For questions regarding patent enforcement issues, applicants may call the U.S. Government hotline at 1-866-999-HALT (1-866-999-4158).

LICENSE FOR FOREIGN FILING UNDER**Title 35, United States Code, Section 184****Title 37, Code of Federal Regulations, 5.11 & 5.15****GRANTED**

The applicant has been granted a license under 35 U.S.C. 184, if the phrase "IF REQUIRED, FOREIGN FILING LICENSE GRANTED" followed by a date appears on this form. Such licenses are issued in all applications where

the conditions for issuance of a license have been met, regardless of whether or not a license may be required as set forth in 37 CFR 5.15. The scope and limitations of this license are set forth in 37 CFR 5.15(a) unless an earlier license has been issued under 37 CFR 5.15(b). The license is subject to revocation upon written notification. The date indicated is the effective date of the license, unless an earlier license of similar scope has been granted under 37 CFR 5.13 or 5.14.

This license is to be retained by the licensee and may be used at any time on or after the effective date thereof unless it is revoked. This license is automatically transferred to any related applications(s) filed under 37 CFR 1.53(d). This license is not retroactive.

The grant of a license does not in any way lessen the responsibility of a licensee for the security of the subject matter as imposed by any Government contract or the provisions of existing laws relating to espionage and the national security or the export of technical data. Licensees should apprise themselves of current regulations especially with respect to certain countries, of other agencies, particularly the Office of Defense Trade Controls, Department of State (with respect to Arms, Munitions and Implements of War (22 CFR 121-128)); the Bureau of Industry and Security, Department of Commerce (15 CFR parts 730-774); the Office of Foreign Assets Control, Department of Treasury (31 CFR Parts 500+) and the Department of Energy.

NOT GRANTED

No license under 35 U.S.C. 184 has been granted at this time, if the phrase "IF REQUIRED, FOREIGN FILING LICENSE GRANTED" DOES NOT appear on this form. Applicant may still petition for a license under 37 CFR 5.12, if a license is desired before the expiration of 6 months from the filing date of the application. If 6 months has lapsed from the filing date of this application and the licensee has not received any indication of a secrecy order under 35 U.S.C. 181, the licensee may foreign file the application pursuant to 37 CFR 5.15(b).

Please Direct All Correspondence to Customer Number 20,995

RESPONSE TO FORMALITIES NOTICE

Applicant	: Steinberg, et al.
App. No	: 12/778,052
Filed	: May 11, 2010
For	: SYSTEM, METHOD AND APPARATUS FOR IDENTIFYING MANUAL INPUTS TO AND ADAPTIVE PROGRAMMING OF A THERMOSTAT
Art Unit	: 3744

Mail Stop Missing Parts
 Commissioner for Patents
 P.O. Box 1450
 Alexandria, VA 22313-1450

Dear Sir:

The above-captioned application was filed without a Declaration and/or filing fees. Enclosed in compliance with 37 CFR 1.53(f) are the following.

- (X) A Declaration in 2 pages.
- (X) General Power of Attorney and Statement Under 37 CFR 3.73(b).
- (X) Replacement Drawings in 11 pages

The present application qualifies for small entity status under 37 CFR § 1.27.

- (X) Fees will be paid via EFS Web. Extension of time is requested by payment of any extension fee.

The Commissioner is hereby authorized to charge any additional fees which may be required, now or in the future, or credit any overpayment, to Account No. 11-1410.

08/27/2010 VVAN11 00000011 111410 12778052

02 FC:2251 65.00 DA

9549479:ad
082010

08/31/2010 VVAN11 00000018 111410 12778052

01 FC:2051 65.00 DA



John R. King
 Registration No. 34,362
 Attorney of Record
 Customer No. 20,995
 (949) 760-0404

**REVOCAION & GENERAL POWER OF ATTORNEY
and
CHANGE IN CORRESPONDENCE ADDRESS**

Commissioner for Patents
P.O. Box 1450
Alexandria, VA 22313-1450

Dear Sir:

The undersigned is an empowered representative of the Assignee and hereby appoints the registrants of Knobbe, Martens, Olson & Bear, LLP, **Customer No. 20,995**, as attorneys and agents to represent the Assignee before the United States Patent and Trademark Office (USPTO) in connection with any and all patent applications assigned to the Assignee according to the USPTO assignment records or assignment documents supplied with an accompanying Statement Under 37 CFR § 3.73(b). This appointment is to be to the exclusion of the inventor(s) and his attorney(s) in accordance with the provisions of 37 CFR § 3.71.

Submission of this paper in connection with any matter of the below named assignee, together with a statement under 37 CFR 3.73(b), shall serve to revoke any previous powers of attorney in that matter.

Attached is a Statement Under 37 CFR § 3.73(b), signed by a registrant of Knobbe, Martens, Olson & Bear, LLP, setting forth a full chain of title for the subject application owned by the Assignee named below.

Please recognize or change the correspondence address for the application identified in the attached Statement to **Customer No. 20,995**.

By: 
John Douglas Steinberg

Date : 7/19/2018

Title: CEO

Assignee: EcoFactor, Inc.

Address: 423 Broadway, #801
Millbrae, CA 94030

**STATEMENT UNDER 37 CFR § 3.73(b)
ESTABLISHMENT OF ASSIGNEE**

Applicant : Steinberg, et al.
App. No. : 12/778,052
Filed : May 11, 2010
For : SYSTEM, METHOD AND APPARATUS FOR IDENTIFYING MANUAL
INPUTS TO AND ADAPTIVE PROGRAMMING OF A THERMOSTAT
Examiner : Unknown
Group Art Unit : 3744

Commissioner for Patents
P.O. Box 1450
Alexandria, VA 22313-1450

Dear Sir:

This document is being filed with a copy of a Power of Attorney signed by the Assignee. This Statement sets forth the chain of title of the above-identified application.

EcoFactor, Inc., a corporation, is the Assignee of the entire right, title, and interest of the above-referenced application by virtue of:

The attached copy of the Assignment being forwarded to the Recordation Branch concurrently under separate cover.

The undersigned is an agent of Customer Number 20,995 and is authorized to act on behalf of the Assignee. Please recognize or change the correspondence address for the above-identified application to **Customer No. 20,995**.

Respectfully submitted,
KNOBBE, MARTENS, OLSON & BEAR, LLP

Dated: 8-20-2010

By: John R. King
John R. King
Registration No. 34,362
Attorney of Record
Customer No. 20,995
(949) 760-0404

ASSIGNMENT

WHEREAS, We, John Douglas Steinberg, a United States citizen, residing at 873 Hacienda Way, Millbrae, CA 94030; Scott Douglas Hublou, a United States citizen, residing at 747 Lakeview Way, Redwood City, CA 94062; and Leo Cheung, a United States citizen, residing at 708 Jackpine Court, Sunnyvale, CA 94086 (hereinafter collectively and individually referred to as "ASSIGNOR"), have invented certain new and useful improvements, technology, inventions, developments ideas or discoveries related to a SYSTEM, METHOD AND APPARATUS FOR IDENTIFYING MANUAL INPUTS TO AND ADAPTIVE PROGRAMMING OF A THERMOSTAT (collectively hereinafter referred to as the "Work") the Work further including an application for Letters Patent in the United States, Application No. 12/778,052, filed on May 11, 2010 (hereinafter referred to as the "Application");

AND WHEREAS, EcoFactor, Inc. (hereinafter "ASSIGNEE"), a California Corporation, with its principal place of business at 423 Broadway, #801, Millbrae, CA 94030, desires to acquire the entire right, title, and interest in and to the Work including the Application:

NOW, THEREFORE, for good and valuable consideration, the receipt of which is hereby acknowledged, ASSIGNOR does hereby acknowledge that ASSIGNOR sold, assigned, transferred and set over, and by these presents and does hereby sell, assign, transfer and set over, unto said ASSIGNEE, its successors, legal representatives and assigns, the entire right, title, and interest throughout the world in, to and under the Work and any improvement made thereto including the Application and all provisional applications relating thereto including, but not limited to, U.S. Provisional Application No. 61/215,999, filed May 12, 2009, and any other related intellectual property rights such as, but not limited to, copyright rights, copyrightable subject matter, know how, trade secrets, copyright registrations, reproduction rights, and waives any and all moral rights under 17 U.S.C. § 106A or otherwise, and all divisions, renewals and continuations thereof, and all Letters Patent of the United States which may be granted thereon and all reissues and extensions thereof, and all rights of priority under International Conventions and applications for Letters Patent which may hereafter be filed for said improvements in any country or countries foreign to the United States, and all Letters Patent which may be granted for said improvements in any country or countries foreign to the United States and all extensions, renewals and reissues thereof; and I hereby authorize and request the Commissioner of Patents of the United States, and any Official of any country or countries foreign to the United States, whose duty it is to issue patents on applications as aforesaid, to issue all Letters Patent for said improvements to said ASSIGNEE, its successors, legal representatives and assigns, in accordance with the terms of this instrument.

ASSIGNOR represents and warrants that to the best of ASSIGNOR's knowledge that ASSIGNOR has not entered into any contract or made any commitments that will or may impair the rights assigned to ASSIGNEE in the Work.

ASSIGNOR DOES HEREBY sell, assign, transfer, and convey to ASSIGNEE, its successors, legal representatives, and assigns all claims for damages and all remedies arising out of any violation of the rights assigned hereby that may have accrued prior to the date of assignment to ASSIGNEE, or may accrue hereafter, including, but not limited to, the right to sue for, collect, and retain damages for past infringements of said Letters Patent before or after issuance.

ASSIGNOR DOES HEREBY covenant and agree to promptly provide any tangible property embodying or describing the Work, including without limitation all documents, drawings, prototypes, models, test results, designs, materials, computer programs and data, and the like, which, if not presently in the possession of ASSIGNEE, will be delivered to ASSIGNEE immediately upon creation thereof.

ASSIGNOR DOES HEREBY covenant and agree to communicate to the ASSIGNEE, its successors, legal representatives and assigns, any facts known to ASSIGNOR respecting the Work, and testify in any legal proceeding, assist in the preparation of any other applications relating to the Work or any improvements made thereto, sign all lawful papers, execute and make all rightful oaths and/or declarations in connection with the Work including any improvements made thereto, any application(s) filed therefrom, and any continuing application(s) filed from aforementioned patent application(s), and generally do everything possible to aid the ASSIGNEE, its successors, legal representatives and assigns, to obtain and enforce proper patent, copyright or other protectable rights for the Work in all countries and ASSIGNOR does hereby appoint ASSIGNEE as ASSIGNOR's attorney-in-fact for the limited purpose of executing all documents and performing all other acts necessary to give effect and legality to this Assignment.

ASSIGNOR DOES HEREBY covenant and agree not to challenge or oppose, on any grounds whatsoever, the validity of this Assignment or to assist or request any third party to contest the validity of this Assignment, and ASSIGNOR further agrees not to contest the validity or enforceability of any intellectual property rights assigned herein, or to assist or request any third party to contest the validity or enforceability of any intellectual property rights assigned herein. Also, no course of conduct or dealing by ASSIGNOR shall act as an amendment, modification or waiver of any provision of this Assignment unless specifically set forth in writing.

IN TESTIMONY WHEREOF, I hereunto sign as follows:

7/19/2010
Date

7/19/2010
Date

7/19/2010
Date

John Douglas Steinberg

Scott Douglas Hublou

Leo Cheung

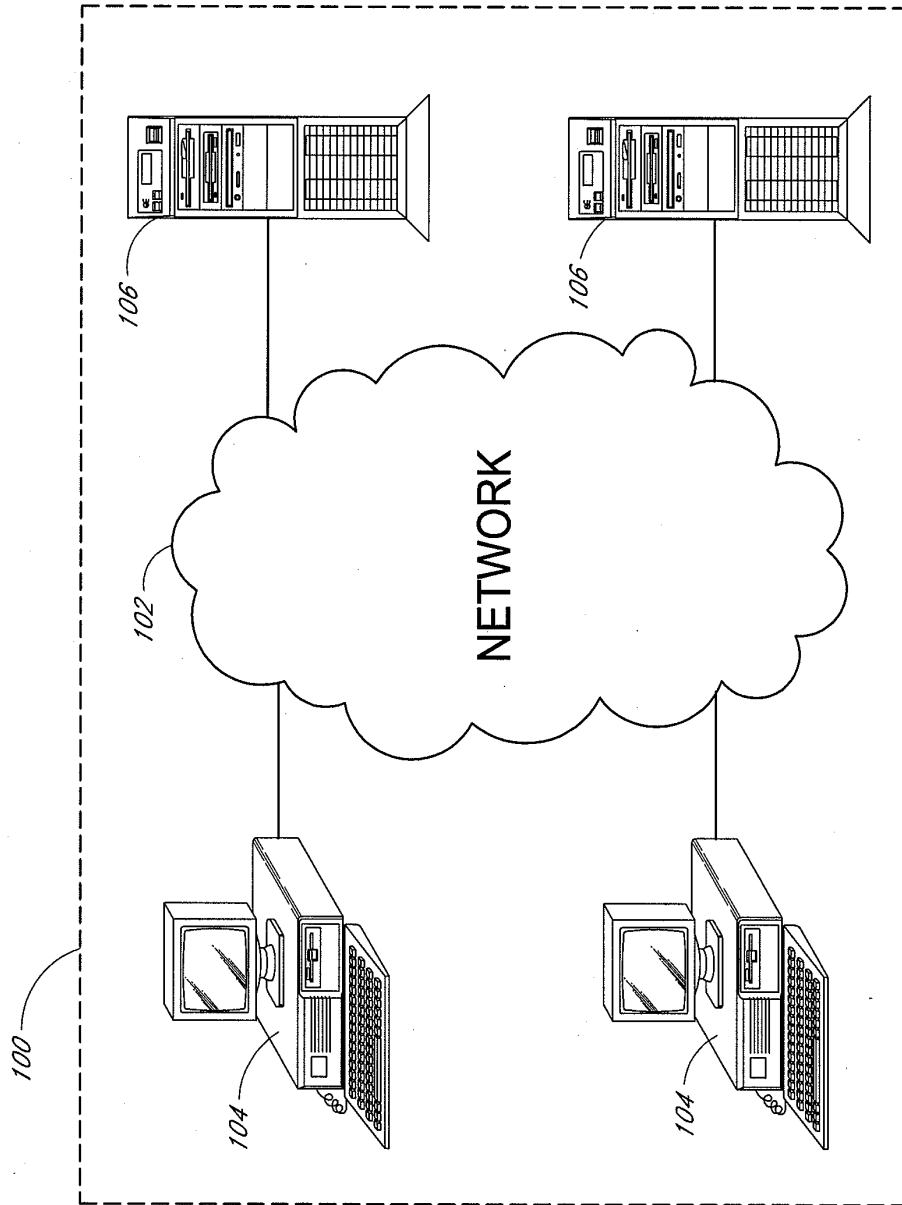

FIG. 1

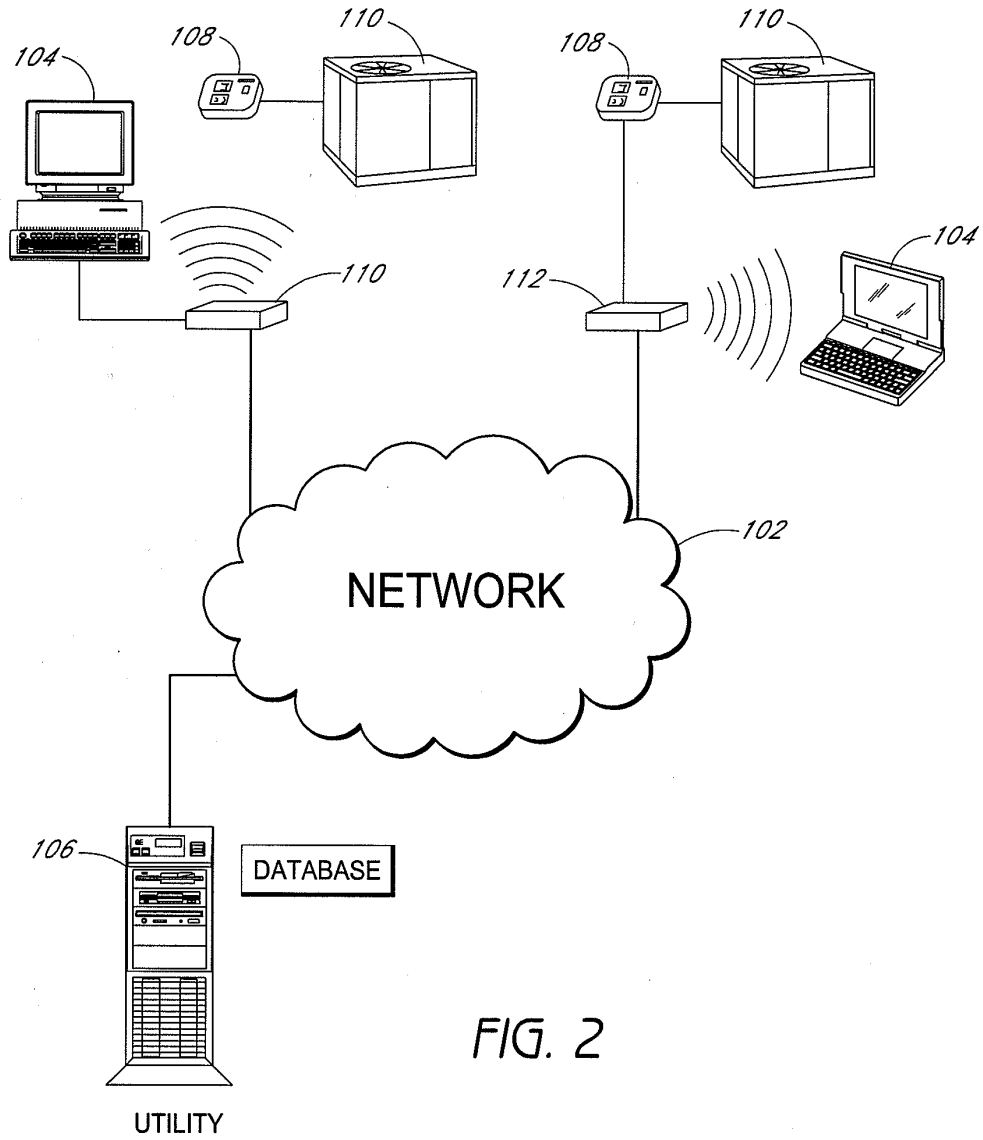

FIG. 2

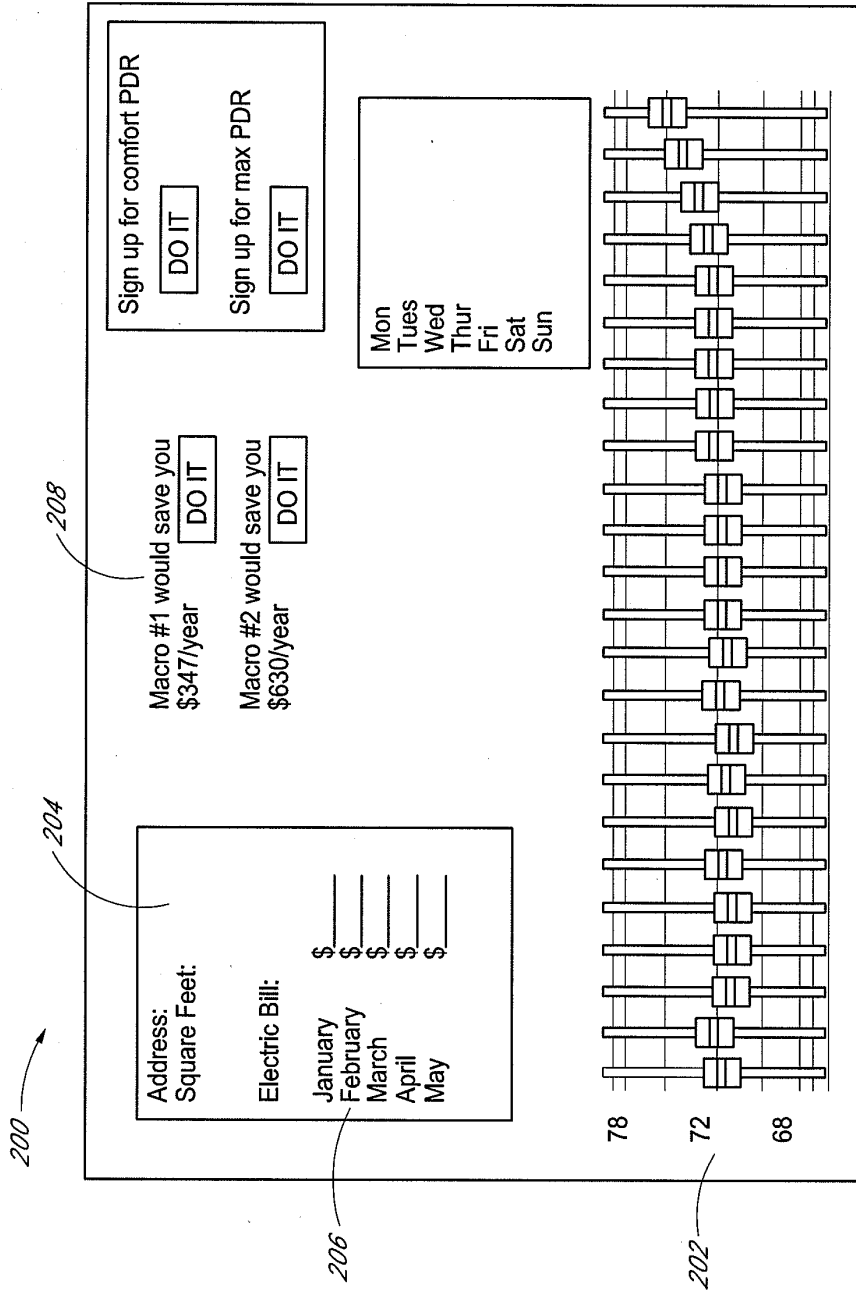

FIG. 3

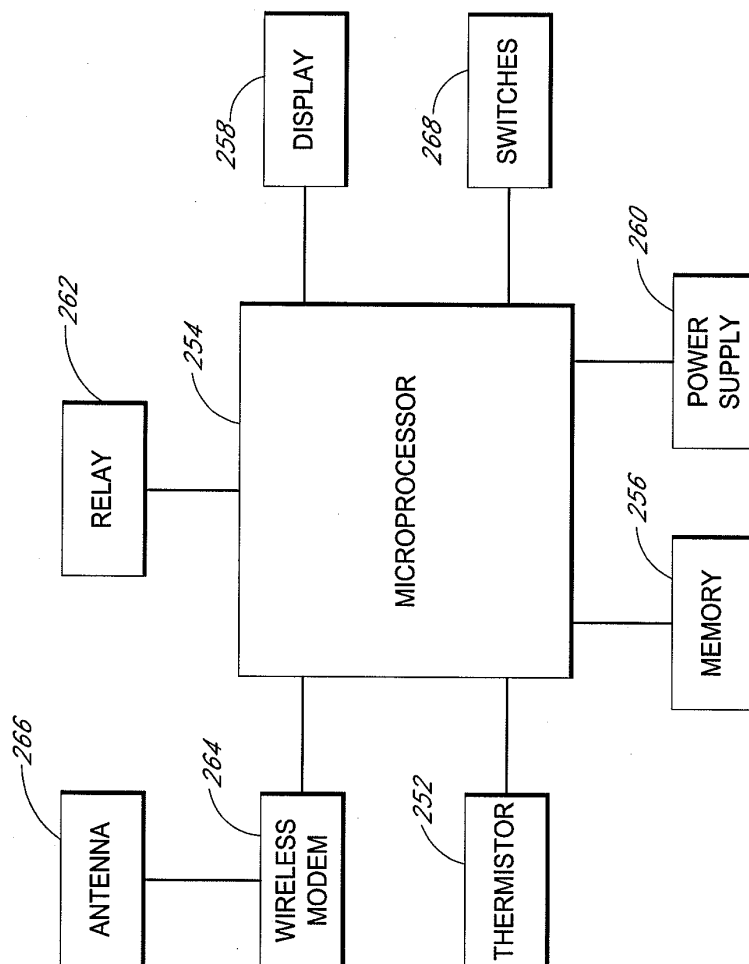

FIG. 4

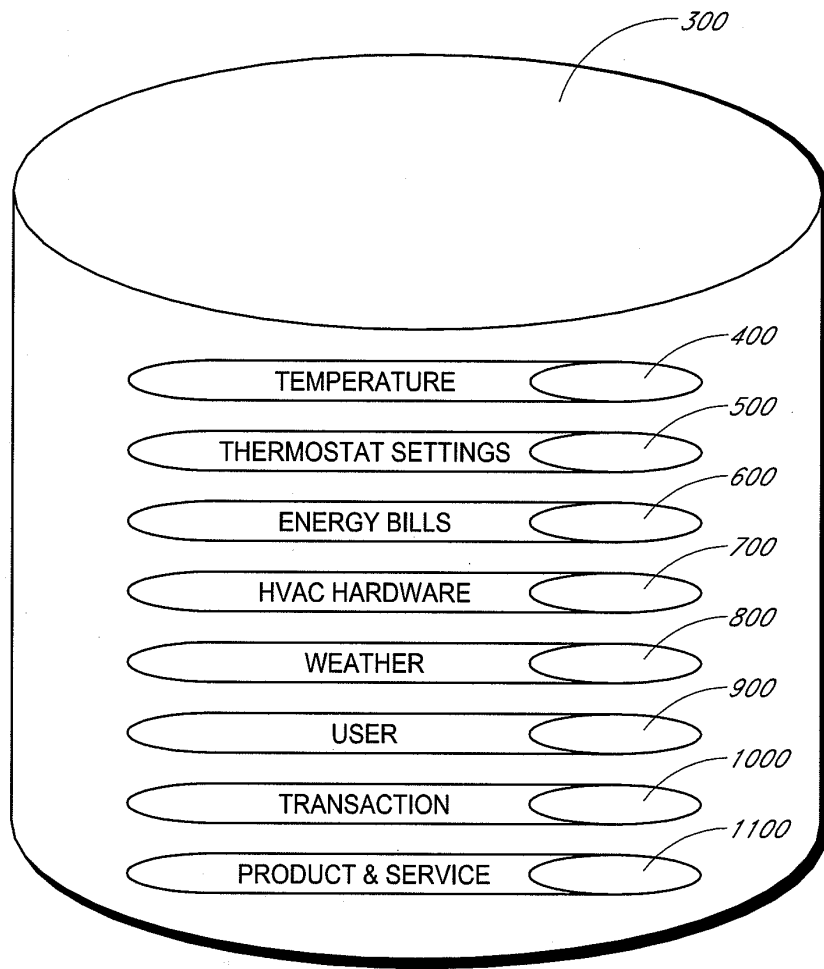

FIG. 5

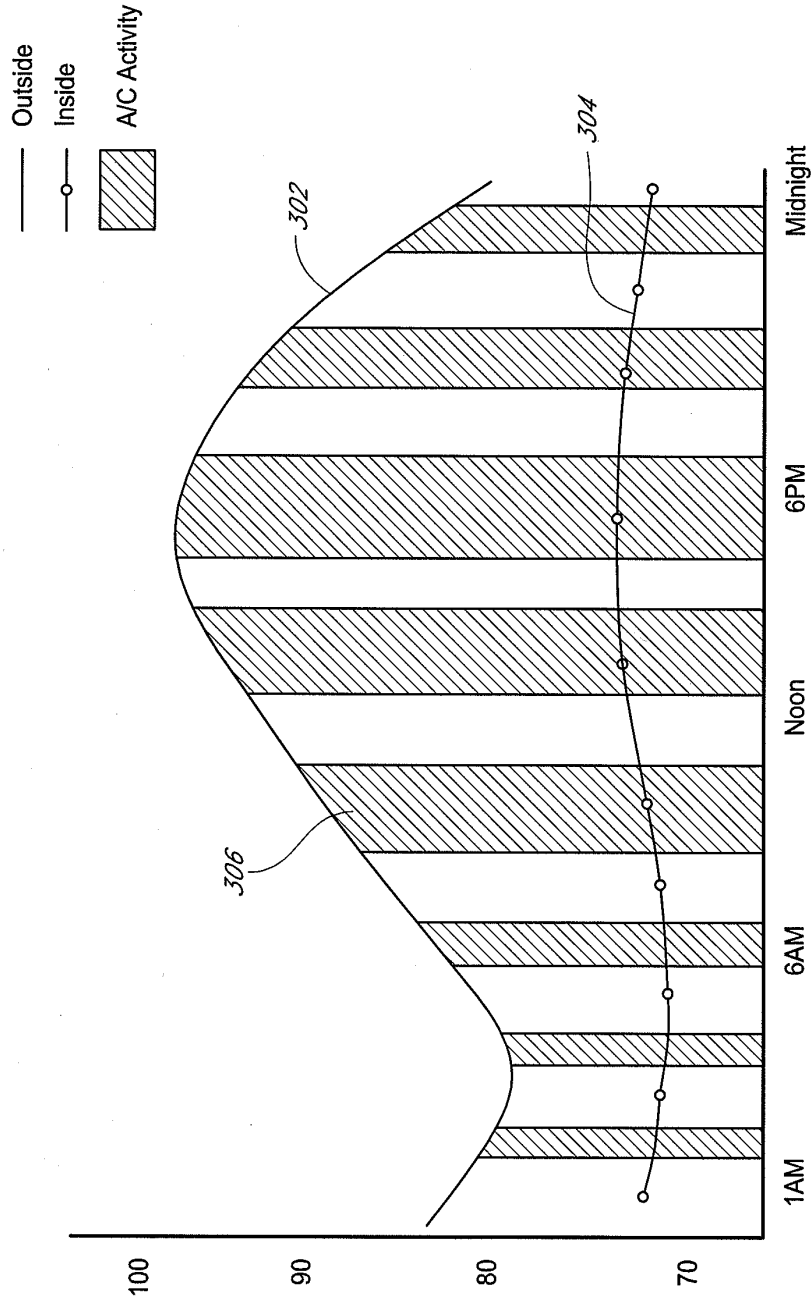

FIG. 6A

7/11

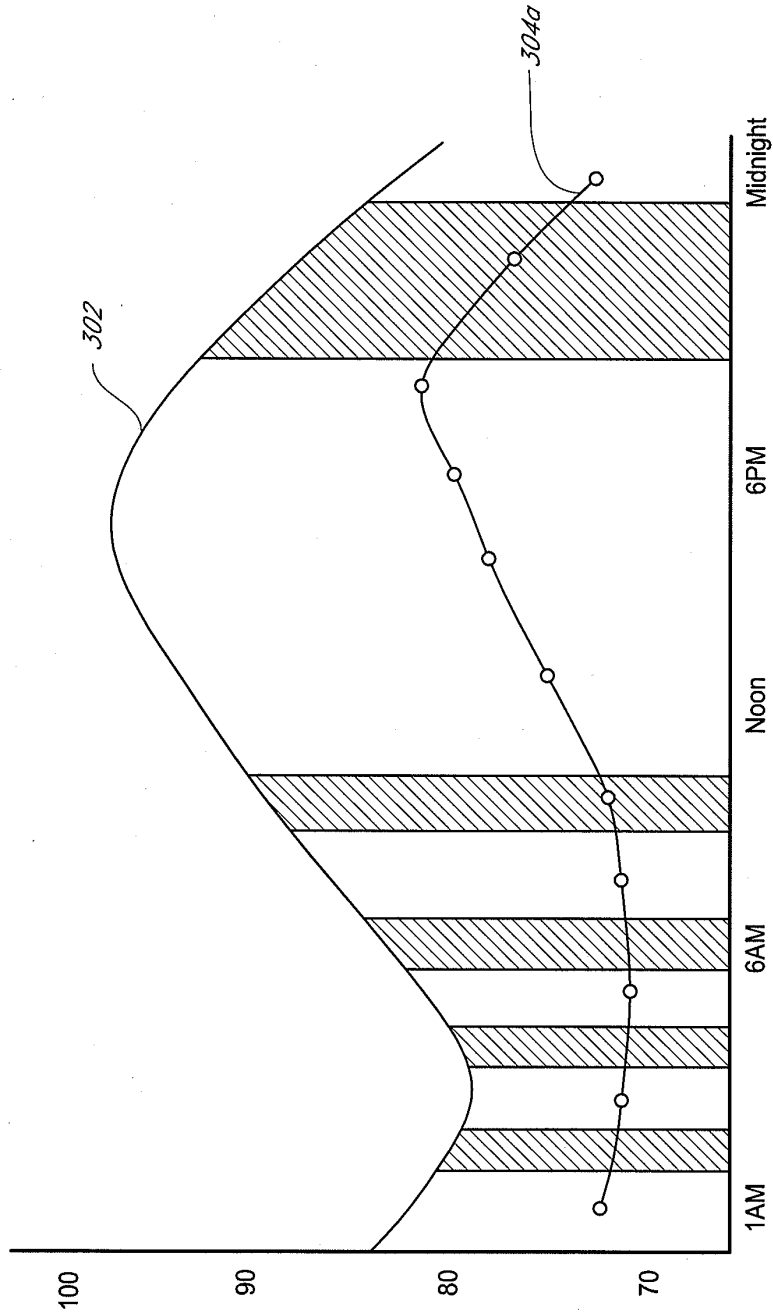

FIG. 6B

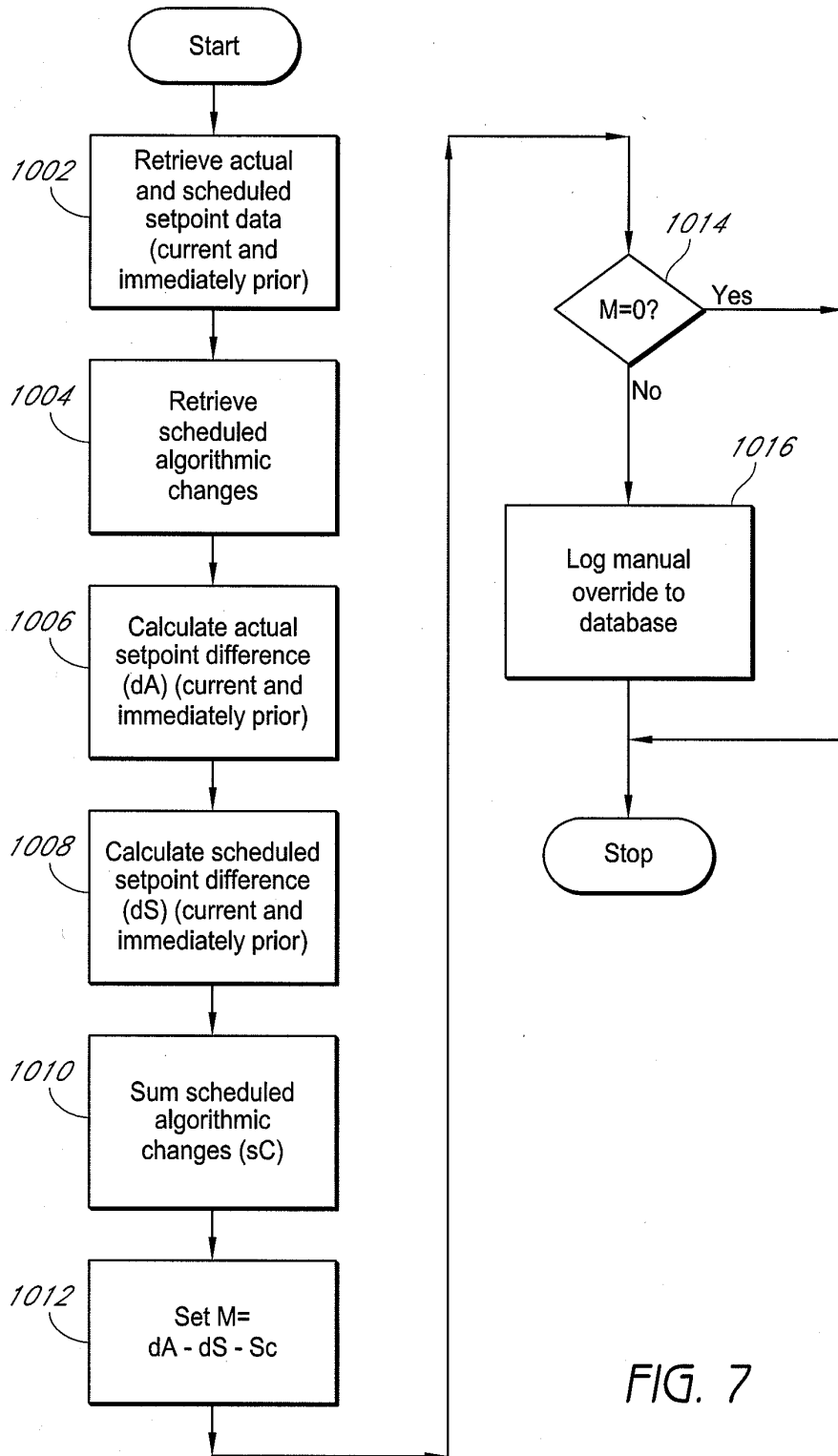

FIG. 7

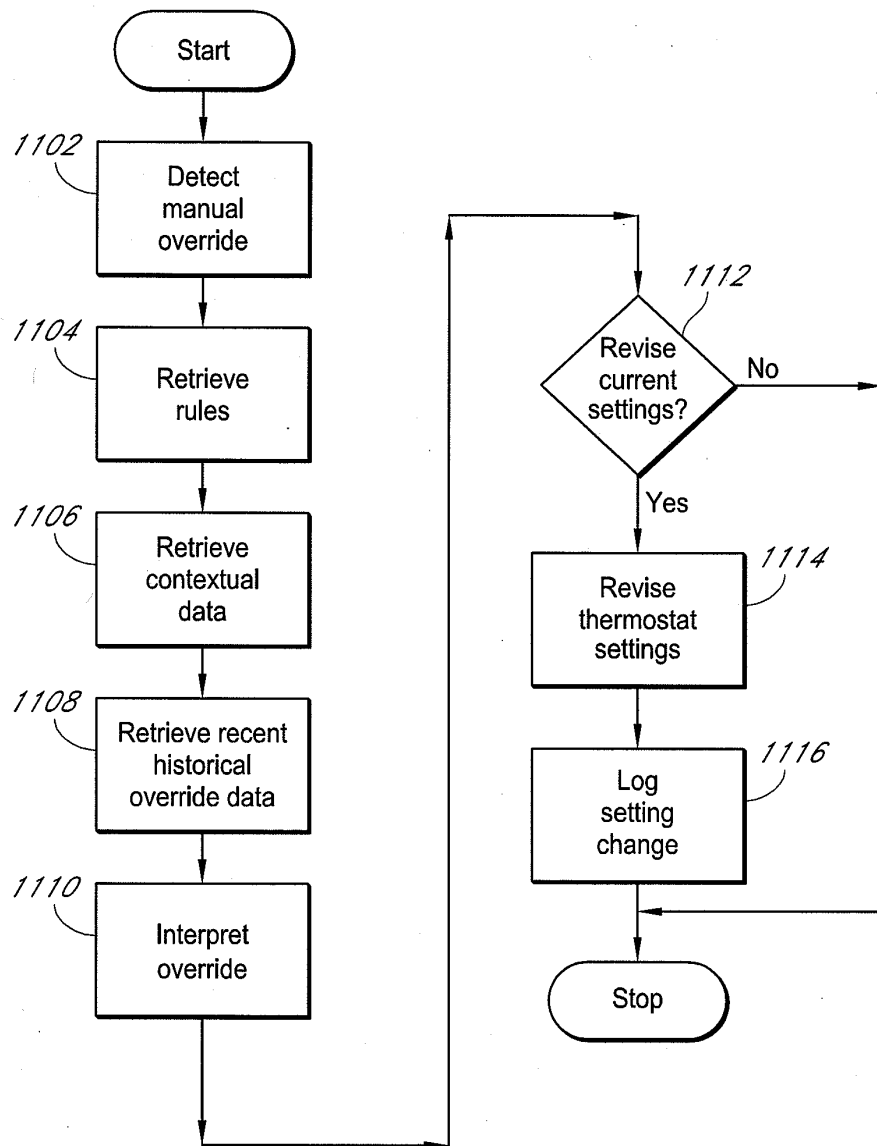

FIG. 8

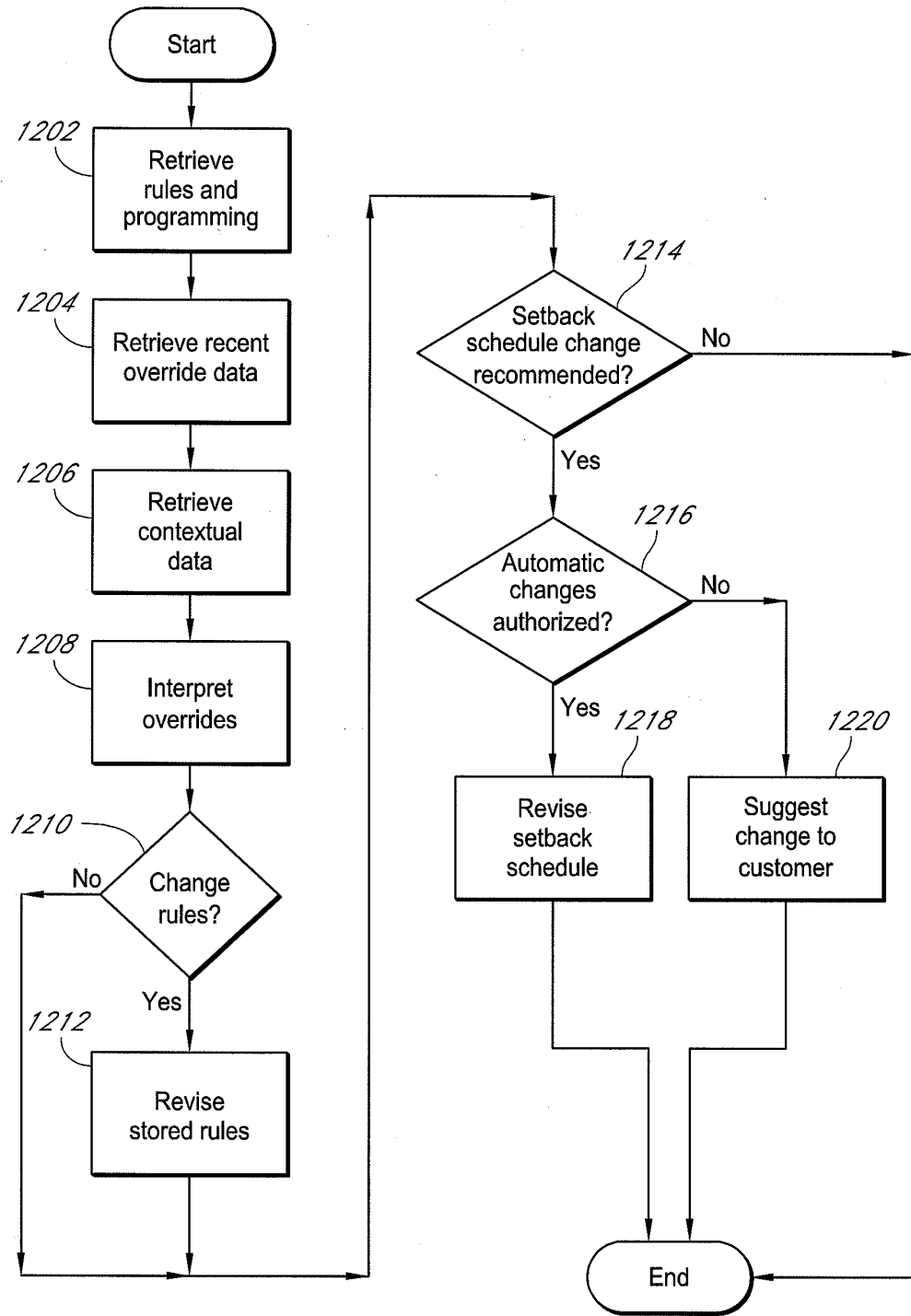

FIG. 9

Time	Temperature		Outside Conditions						Inside Conditions						
	Inside Temp.	Outside Temp.	Conditions	Humidity	Pressure	Wind Speed	Wind Direction	Cool Setting	Heat Setting	Hold Mode	Schd Setting	Schd Cool	Schd Heat	Hvac State	Hvac Mode
2009/04/10 11:00	69.70	54.00	Mostly Cloudy	74%	29.89in/ 1012.1hPa Steady	1.0mph 1.6kph	SE	80.00	71.00	Off	Out/Day	80.00	65.00	Heat	Heat
2009/04/10 11:01	69.69	54.10	Overcast	74%	29.89in/ 1012.1hPa Rising	2.0mph 3.2kph	SE	80.00	71.00	Off	Out/Day	80.00	65.00	Heat	Heat
2009/04/10 11:02	69.60	54.10	Overcast	74%	29.89in/ 1012.1hPa Steady	2.0mph 3.2kph	SE	80.00	71.00	Off	Out/Day	80.00	65.00	Heat	Heat
2009/04/10 11:03	69.70	54.10	Overcast	74%	29.89in/ 1012.1hPa Rising	2.0mph 3.2kph	SE	80.00	71.00	Off	Out/Day	80.00	65.00	Heat	Heat
2009/04/10 11:04	69.70	54.10	Overcast	74%	29.89in/ 1012.1hPa Steady	2.0mph 3.2kph	SE	80.00	71.00	Off	Out/Day	80.00	65.00	Heat	Heat
2009/04/10 11:05	69.70	54.10	Overcast	74%	29.89in/ 1012.1hPa Rising	2.0mph 3.2kph	SE	80.00	71.00	Off	Out/Day	80.00	65.00	Heat	Heat
2009/04/10 11:06	69.80	54.70	Overcast	72%	29.89in/ 1012.1hPa Steady	2.0mph 3.2kph	SE	80.00	71.00	Off	Out/Day	80.00	65.00	Heat	Heat
2009/04/10 11:07	69.80	54.70	Overcast	72%	29.89in/ 1012.1hPa Rising	2.0mph 3.2kph	SE	80.00	71.00	Off	Out/Day	80.00	65.00	Heat	Heat
2009/04/10 11:08	70.00	54.70	Overcast	72%	29.89in/ 1012.1hPa Steady	2.0mph 3.2kph	SE	80.00	71.00	Off	Out/Day	80.00	65.00	Heat	Heat
2009/04/10 11:09	70.00	54.70	Overcast	72%	29.89in/ 1012.1hPa Rising	2.0mph 3.2kph	SE	80.00	71.00	Off	Out/Day	80.00	65.00	Heat	Heat
2009/04/10 11:10	70.00	54.70	Overcast	72%	29.89in/ 1012.1hPa Steady	2.0mph 3.2kph	SE	80.00	71.00	Off	Out/Day	80.00	65.00	Heat	Heat

FIG. 10

Electronic Patent Application Fee Transmittal

Application Number:	12778052			
Filing Date:	11-May-2010			
Title of Invention:	SYSTEM, METHOD AND APPARATUS FOR IDENTIFYING MANUAL INPUTS TO AND ADAPTIVE PROGRAMMING OF A THERMOSTAT			
First Named Inventor/Applicant Name:	John Douglas Steinberg			
Filer:	John R. King/Amy Durrant			
Attorney Docket Number:	EFACT.007A			
Filed as Small Entity				
Utility under 35 USC 111 (a) Filing Fees				
Description	Fee Code	Quantity	Amount	Sub-Total in USD(\$)
Basic Filing:				
Utility filing Fee (Electronic filing)	4011	1	82	82
Utility Search Fee	2111	1	270	270
Utility Examination Fee	2311	1	110	110
Pages:				
Claims:				
Claims in excess of 20	2202	3	26	78
Miscellaneous-Filing:				
Late filing fee for oath or declaration	2051	1	65	65

Description	Fee Code	Quantity	Amount	Sub-Total in USD(\$)
Petition:				
Patent-Appeals-and-Interference:				
Post-Allowance-and-Post-Issuance:				
Extension-of-Time:				
Extension - 1 month with \$0 paid	2251	1	65	65
Miscellaneous:				
Total in USD (\$)				670

Electronic Acknowledgement Receipt

EFS ID:	8259956
Application Number:	12778052
International Application Number:	
Confirmation Number:	5650
Title of Invention:	SYSTEM, METHOD AND APPARATUS FOR IDENTIFYING MANUAL INPUTS TO AND ADAPTIVE PROGRAMMING OF A THERMOSTAT
First Named Inventor/Applicant Name:	John Douglas Steinberg
Customer Number:	20995
Filer:	John R. King/Shirley Martinez
Filer Authorized By:	John R. King
Attorney Docket Number:	EFACT.007A
Receipt Date:	20-AUG-2010
Filing Date:	11-MAY-2010
Time Stamp:	17:21:30
Application Type:	Utility under 35 USC 111(a)

Payment information:

Submitted with Payment	no
------------------------	----

File Listing:

Document Number	Document Description	File Name	File Size(Bytes)/ Message Digest	Multi Part /.zip	Pages (if appl.)
1	Applicant Response to Pre-Exam Formalities Notice	EFACT-007A_trans.pdf	36675 b3f9e5a1f2650a759167401583a29badbe0520c3	no	1

Warnings:

Information:

2	Oath or Declaration filed	EFACT-007A_decl.pdf	101337 3e19bac659e16974bdcf3a2020ae6905ede0f1e2	no	2
Warnings:					
Information:					
3	Power of Attorney	EFACT-007A_poa.pdf	54579 d89669cd1306fd094a7767087bfbfb77b079623	no	1
Warnings:					
Information:					
4	Assignee showing of ownership per 37 CFR 3.73(b).	EFACT-007A_stmnt373.pdf	212706 d9958b245de14aff10f1aa83194a754a8fdd27d	no	3
Warnings:					
Information:					
5	Drawings-only black and white line drawings	EFACT-007A_drwgs.pdf	281762 5b5e563288bea7b2152f3fe5bcde3824729db4c7	no	11
Warnings:					
Information:					
6	Fee Worksheet (PTO-875)	fee-info.pdf	40383 e4ae955b6733f160d6ca2368cb9126945a1354ed	no	2
Warnings:					
Information:					
Total Files Size (in bytes):				727442	
<p>This Acknowledgement Receipt evidences receipt on the noted date by the USPTO of the indicated documents, characterized by the applicant, and including page counts, where applicable. It serves as evidence of receipt similar to a Post Card, as described in MPEP 503.</p> <p><u>New Applications Under 35 U.S.C. 111</u> If a new application is being filed and the application includes the necessary components for a filing date (see 37 CFR 1.53(b)-(d) and MPEP 506), a Filing Receipt (37 CFR 1.54) will be issued in due course and the date shown on this Acknowledgement Receipt will establish the filing date of the application.</p> <p><u>National Stage of an International Application under 35 U.S.C. 371</u> If a timely submission to enter the national stage of an international application is compliant with the conditions of 35 U.S.C. 371 and other applicable requirements a Form PCT/DO/EO/903 indicating acceptance of the application as a national stage submission under 35 U.S.C. 371 will be issued in addition to the Filing Receipt, in due course.</p> <p><u>New International Application Filed with the USPTO as a Receiving Office</u> If a new international application is being filed and the international application includes the necessary components for an international filing date (see PCT Article 11 and MPEP 1810), a Notification of the International Application Number and of the International Filing Date (Form PCT/RO/105) will be issued in due course, subject to prescriptions concerning national security, and the date shown on this Acknowledgement Receipt will establish the international filing date of the application.</p>					

Please Direct All Correspondence to Customer Number 20,995

RESPONSE TO FORMALITIES NOTICE

Applicant : Steinberg, et al.
App. No : 12/778,052
Filed : May 11, 2010
For : SYSTEM, METHOD AND APPARATUS FOR
IDENTIFYING MANUAL INPUTS TO AND
ADAPTIVE PROGRAMMING OF A
THERMOSTAT
Art Unit : 3744

**Mail Stop Missing Parts
Commissioner for Patents
P.O. Box 1450
Alexandria, VA 22313-1450**

Dear Sir:

The above-captioned application was filed without a Declaration and/or filing fees. Enclosed in compliance with 37 CFR 1.53(f) are the following.

- (X) A Declaration in 2 pages.
- (X) General Power of Attorney and Statement Under 37 CFR 3.73(b).
- (X) Replacement Drawings in 11 pages

The present application qualifies for small entity status under 37 CFR § 1.27.

- (X) Fees will be paid via EFS Web. Extension of time is requested by payment of any extension fee.

The Commissioner is hereby authorized to charge any additional fees which may be required, now or in the future, or credit any overpayment, to Account No. 11-1410.

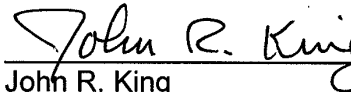

John R. King
Registration No. 34,362
Attorney of Record
Customer No. 20,995
(949) 760-0404

**DECLARATION FOR UTILITY OR DESIGN APPLICATION
UNDER 37 CFR 1.63**

Docket No.: EFACT.007A

Page 1 of 2

Title: SYSTEM, METHOD AND APPARATUS FOR IDENTIFYING MANUAL INPUTS TO
AND ADAPTIVE PROGRAMMING OF A THERMOSTAT

Inventors: John Douglas Steinberg, Scott Douglas Hublou and Leo Cheung

Please Direct All Correspondence to Customer Number 20,995

This Declaration is directed to the invention described in the application that:

Was filed as Application No. 12/778,052 filed on May 11, 2010

As a below named inventor:

I believe the inventor(s) named below to be the original and first inventor(s) of the subject matter which is described and claimed and for which a patent is sought;

I have reviewed and understand the contents of the above-identified application, including the claims, and any amendment filed herewith or identified above;

I acknowledge the duty to disclose information which is material to patentability as defined in 37 CFR 1.56;

I hereby declare that all statements made herein of my own knowledge are true and that all statements made on information and belief are believed to be true; and further that these statements were made with the knowledge that willful false statements and the like so made are punishable by fine or imprisonment, or both, under Section 1001 of Title 18 of the United States Code and that such willful, false statements may jeopardize the validity of the application or any patent issued thereon.

Full name of first inventor: John Douglas Steinberg

Signature: _____

Date: _____

7/17/2010

Citizenship: _____

United States

Mailing Address: _____

873 Hacienda Way, Millbrae, CA 94030

Residence Address: _____

Same as above.

(if different than above)

**DECLARATION FOR UTILITY OR DESIGN APPLICATION
UNDER 37 CFR 1.63**

Docket No.: EFACT.007A

Page 2 of 2

Title: SYSTEM, METHOD AND APPARATUS FOR IDENTIFYING MANUAL INPUTS TO
AND ADAPTIVE PROGRAMMING OF A THERMOSTAT

Inventors: John Douglas Steinberg, Scott Douglas Hublou and Leo Cheung

Please Direct All Correspondence to Customer Number 20,995

Full name of second inventor: Scott Douglas Hublou

Signature: _____

Date: _____

Citizenship: _____

United States

Mailing Address: _____

747 Lakeview Way, Redwood City, CA 94062

Residence Address: _____

Same as above.

(if different than above)

Full name of third inventor: Leo Cheung

Signature: _____

Date: _____

Citizenship: _____

United States

Mailing Address: _____

708 Jackpine Court, Sunnyvale, CA 94086

Residence Address: _____

Same as above.

(if different than above)

Send Correspondence To:
KNOBBE, MARTENS, OLSON & BEAR, LLP
Customer No. 20,995

9153706:ad
060410



UNITED STATES PATENT AND TRADEMARK OFFICE

UNITED STATES DEPARTMENT OF COMMERCE
United States Patent and Trademark Office
Address: COMMISSIONER FOR PATENTS
P.O. Box 1450
Alexandria, Virginia 22313-1450
www.uspto.gov

Table with 4 columns: APPLICATION NUMBER (12/778,052), FILING OR 371(C) DATE (05/11/2010), FIRST NAMED APPLICANT (John Douglas Steinberg), ATTY. DOCKET NO./TITLE (EFACT.007A)

CONFIRMATION NO. 5650

FORMALITIES LETTER



20995
KNOBBE MARTENS OLSON & BEAR LLP
2040 MAIN STREET
FOURTEENTH FLOOR
IRVINE, CA 92614

Date Mailed: 06/02/2010

NOTICE TO FILE MISSING PARTS OF NONPROVISIONAL APPLICATION

FILED UNDER 37 CFR 1.53(b)

Filing Date Granted

Items Required To Avoid Abandonment:

An application number and filing date have been accorded to this application. The item(s) indicated below, however, are missing. Applicant is given TWO MONTHS from the date of this Notice within which to file all required items and pay any fees required below to avoid abandonment.

- The oath or declaration is missing. A properly signed oath or declaration in compliance with 37 CFR 1.63, identifying the application by the above Application Number and Filing Date, is required. Note: If a petition under 37 CFR 1.47 is being filed, an oath or declaration in compliance with 37 CFR 1.63 signed by all available joint inventors, or if no inventor is available by a party with sufficient proprietary interest, is required.

The application is informal since it does not comply with the regulations for the reason(s) indicated below.

The required item(s) identified below must be timely submitted to avoid abandonment:

- Replacement drawings in compliance with 37 CFR 1.84 and 37 CFR 1.121(d) are required. The drawings submitted are not acceptable because:
- The drawings must be reasonably free from erasures and must be free from alterations, overwriting, interlineations, folds, and copy marks. See Figure(s) 1.
- The drawings have a line quality that is too light to be reproduced (weight of all lines and letters must be heavy enough to permit adequate reproduction) or text that is illegible (reference characters, sheet numbers, and view numbers must be plain and legible) see 37 CFR 1.84(l) and (p)(1)); See Figure(s) 10.
- Numbers, letters, and reference characters on the drawings must measure at least 0.32 cm (1/8 inch) in height. See Figure(s) 10.
- The drawings submitted to the Office are not electronically reproducible because portions of figures 10 are missing and/or blurry.

Applicant is cautioned that correction of the above items may cause the specification and drawings page count to exceed 100 pages. If the specification and drawings exceed 100 pages, applicant will need to submit the required application size fee.

The applicant needs to satisfy supplemental fees problems indicated below.

The required item(s) identified below must be timely submitted to avoid abandonment:

- To avoid abandonment, a surcharge (for late submission of filing fee, search fee, examination fee or oath or declaration) as set forth in 37 CFR 1.16(f) of **\$65** for a small entity in compliance with 37 CFR 1.27, must be submitted with the missing items identified in this notice.

SUMMARY OF FEES DUE:

Total additional fee(s) required for this application is **\$65** for a small entity

- **\$65** Surcharge.

Replies should be mailed to:

Mail Stop Missing Parts
Commissioner for Patents
P.O. Box 1450
Alexandria VA 22313-1450

Registered users of EFS-Web may alternatively submit their reply to this notice via EFS-Web.

<https://portal.uspto.gov/authenticate/AuthenticateUserLocalEPF.html>

For more information about EFS-Web please call the USPTO Electronic Business Center at **1-866-217-9197** or visit our website at <http://www.uspto.gov/ebc>.

If you are not using EFS-Web to submit your reply, you must include a copy of this notice.

/atesfaye/

Office of Data Management, Application Assistance Unit (571) 272-4000, or (571) 272-4200, or 1-888-786-0101



UNITED STATES PATENT AND TRADEMARK OFFICE

UNITED STATES DEPARTMENT OF COMMERCE
United States Patent and Trademark Office
Address: COMMISSIONER FOR PATENTS
P.O. Box 1450
Alexandria, Virginia 22313-1450
www.uspto.gov

Table with 6 columns: APPLICATION NUMBER, FILING or 371(c) DATE, GRP ART UNIT, FIL FEE REC'D, ATTY.DOCKET.NO, TOT CLAIMS, IND CLAIMS. Row 1: 12/778,052, 05/11/2010, 3744, 540, EFACT.007A, 23, 3

CONFIRMATION NO. 5650

FILING RECEIPT



20995
KNOBBE MARTENS OLSON & BEAR LLP
2040 MAIN STREET
FOURTEENTH FLOOR
IRVINE, CA 92614

Date Mailed: 06/02/2010

Receipt is acknowledged of this non-provisional patent application. The application will be taken up for examination in due course. Applicant will be notified as to the results of the examination. Any correspondence concerning the application must include the following identification information: the U.S. APPLICATION NUMBER, FILING DATE, NAME OF APPLICANT, and TITLE OF INVENTION. Fees transmitted by check or draft are subject to collection. Please verify the accuracy of the data presented on this receipt. If an error is noted on this Filing Receipt, please submit a written request for a Filing Receipt Correction. Please provide a copy of this Filing Receipt with the changes noted thereon. If you received a "Notice to File Missing Parts" for this application, please submit any corrections to this Filing Receipt with your reply to the Notice. When the USPTO processes the reply to the Notice, the USPTO will generate another Filing Receipt incorporating the requested corrections

Applicant(s)

John Douglas Steinberg, Millbrae, CA;
Scott Douglas Hublou, Redwood City, CA;
Leo Cheung, Sunnyvale, CA;

Assignment For Published Patent Application

ECOFACOR, INC., Millbrae, CA

Power of Attorney: None

Domestic Priority data as claimed by applicant

This appln claims benefit of 61/215,999 05/12/2009

Foreign Applications

If Required, Foreign Filing License Granted: 05/28/2010

The country code and number of your priority application, to be used for filing abroad under the Paris Convention, is US 12/778,052

Projected Publication Date: To Be Determined - pending completion of Missing Parts

Non-Publication Request: No

Early Publication Request: No

** SMALL ENTITY **

Title

SYSTEM, METHOD AND APPARATUS FOR IDENTIFYING MANUAL INPUTS TO AND ADAPTIVE PROGRAMMING OF A THERMOSTAT

Preliminary Class

236

PROTECTING YOUR INVENTION OUTSIDE THE UNITED STATES

Since the rights granted by a U.S. patent extend only throughout the territory of the United States and have no effect in a foreign country, an inventor who wishes patent protection in another country must apply for a patent in a specific country or in regional patent offices. Applicants may wish to consider the filing of an international application under the Patent Cooperation Treaty (PCT). An international (PCT) application generally has the same effect as a regular national patent application in each PCT-member country. The PCT process **simplifies** the filing of patent applications on the same invention in member countries, but **does not result** in a grant of "an international patent" and does not eliminate the need of applicants to file additional documents and fees in countries where patent protection is desired.

Almost every country has its own patent law, and a person desiring a patent in a particular country must make an application for patent in that country in accordance with its particular laws. Since the laws of many countries differ in various respects from the patent law of the United States, applicants are advised to seek guidance from specific foreign countries to ensure that patent rights are not lost prematurely.

Applicants also are advised that in the case of inventions made in the United States, the Director of the USPTO must issue a license before applicants can apply for a patent in a foreign country. The filing of a U.S. patent application serves as a request for a foreign filing license. The application's filing receipt contains further information and guidance as to the status of applicant's license for foreign filing.

Applicants may wish to consult the USPTO booklet, "General Information Concerning Patents" (specifically, the section entitled "Treaties and Foreign Patents") for more information on timeframes and deadlines for filing foreign patent applications. The guide is available either by contacting the USPTO Contact Center at 800-786-9199, or it can be viewed on the USPTO website at <http://www.uspto.gov/web/offices/pac/doc/general/index.html>.

For information on preventing theft of your intellectual property (patents, trademarks and copyrights), you may wish to consult the U.S. Government website, <http://www.stopfakes.gov>. Part of a Department of Commerce initiative, this website includes self-help "toolkits" giving innovators guidance on how to protect intellectual property in specific countries such as China, Korea and Mexico. For questions regarding patent enforcement issues, applicants may call the U.S. Government hotline at 1-866-999-HALT (1-866-999-4158).

LICENSE FOR FOREIGN FILING UNDER**Title 35, United States Code, Section 184****Title 37, Code of Federal Regulations, 5.11 & 5.15****GRANTED**

The applicant has been granted a license under 35 U.S.C. 184, if the phrase "IF REQUIRED, FOREIGN FILING LICENSE GRANTED" followed by a date appears on this form. Such licenses are issued in all applications where

the conditions for issuance of a license have been met, regardless of whether or not a license may be required as set forth in 37 CFR 5.15. The scope and limitations of this license are set forth in 37 CFR 5.15(a) unless an earlier license has been issued under 37 CFR 5.15(b). The license is subject to revocation upon written notification. The date indicated is the effective date of the license, unless an earlier license of similar scope has been granted under 37 CFR 5.13 or 5.14.

This license is to be retained by the licensee and may be used at any time on or after the effective date thereof unless it is revoked. This license is automatically transferred to any related applications(s) filed under 37 CFR 1.53(d). This license is not retroactive.

The grant of a license does not in any way lessen the responsibility of a licensee for the security of the subject matter as imposed by any Government contract or the provisions of existing laws relating to espionage and the national security or the export of technical data. Licensees should apprise themselves of current regulations especially with respect to certain countries, of other agencies, particularly the Office of Defense Trade Controls, Department of State (with respect to Arms, Munitions and Implements of War (22 CFR 121-128)); the Bureau of Industry and Security, Department of Commerce (15 CFR parts 730-774); the Office of Foreign Assets Control, Department of Treasury (31 CFR Parts 500+) and the Department of Energy.

NOT GRANTED

No license under 35 U.S.C. 184 has been granted at this time, if the phrase "IF REQUIRED, FOREIGN FILING LICENSE GRANTED" DOES NOT appear on this form. Applicant may still petition for a license under 37 CFR 5.12, if a license is desired before the expiration of 6 months from the filing date of the application. If 6 months has lapsed from the filing date of this application and the licensee has not received any indication of a secrecy order under 35 U.S.C. 181, the licensee may foreign file the application pursuant to 37 CFR 5.15(b).

INFORMATION DISCLOSURE STATEMENT

Applicant	: Steinberg, et al.
App. No	: Unknown
Filed	: Herewith
For	: SYSTEM, METHOD AND APPARATUS FOR IDENTIFYING MANUAL INPUTS TO AND ADAPTIVE PROGRAMMING OF A THERMOSTAT
Examiner	: Unknown
Art Unit	: Unknown
Conf No.	: Unknown

Commissioner for Patents
P.O. Box 1450
Alexandria, VA 22313-1450

Dear Sir:

Enclosed for filing in the above-identified application is a PTO/SB/08 Equivalent listing seventy eight (78) references, of which fourteen (14) are enclosed/submitted.

This Information Disclosure Statement is being filed within three months of the filing date and no fee is required.

The Commissioner is hereby authorized to charge any additional fees which may be required, or credit any overpayment, to Account No. 11-1410.

05/28/2010 MNGUYEN 00000009 111410 12778052

01 FC:4011	82.00 DA
02 FC:2111	270.00 DA
03 FC:2311	110.00 DA
04 FC:2202	78.00 DA

Respectfully submitted,

KNOBBE, MARTENS, OLSON & BEAR, LLP

Dated: 5-11-2010

By: John R. King

John R. King
Registration No. 34,362
Attorney of Record
Customer No. 20,995
(949) 760-0404

9021475:ad
050710

INFORMATION DISCLOSURE STATEMENT BY APPLICANT	Application No.	Unknown
	Filing Date	Herewith
	First Named Inventor	Steinberg, John Douglas et al
	Art Unit	
<i>(Multiple sheets used when necessary)</i>		Examiner
SHEET 1 OF 4		Attorney Docket No. EFACT.007A

U.S. PATENT DOCUMENTS					
Examiner Initials	Cite No.	Document Number <i>Number - Kind Code (if known)</i> Example: 1,234,567 B1	Publication Date MM-DD-YYYY	Name of Patentee or Applicant	Pages, Columns, Lines Where Relevant Passages or Relevant Figures Appear
	1	4,403,644	09-13-1983	Raymond T.	
	2	4,674,027	06-16-1987	Beckey	
	3	5,572,438	11-05-1996	Ehlers, et al.	
	4	5,717,609	02-10-1998	Packa, et al.	
	5	6,145,751	11-14-2000	Ahmed	
	6	6,178,362	01-23-2001	Woolard, et al.	
	7	6,351,693	02-26-2002	Monie	
	8	6,400,996	06-04-2002	Hoffberg, et al.	
	9	6,437,692	08-20-2002	Petite, et al.	
	10	6,478,233	11-12-2002	Shah	
	11	6,480,803	11-12-2002	Pierret, et al.	
	12	6,483,906	11-19-2002	Lggulden, et al.	
	13	6,536,675	03-25-2003	Pesko, et al.	
	14	6,542,076	04-01-2003	Joao	
	15	6,549,130	04-15-2003	Joao	
	16	6,574,537	06-02-2003	Kipersztok, et al.	
	17	6,580,950	06-17-2003	Johnson	
	18	6,594,825	07-15-2003	Goldschmidtiki, et al.	
	19	6,595,430	07-22-2003	Shah	
	20	6,598,056	07-22-2003	Hull, et al.	
	21	6,619,555	09-16-2003	Rosen	
	22	6,622,097	09-16-2003	Hunter	
	23	6,622,115	09-16-2003	Brown, et al.	
	24	6,622,925	09-23-2003	Carner, et al.	
	25	6,622,926	09-23-2003	Sartain, et al.	
	26	6,628,997	09-30-2003	Fox, et al.	
	27	6,633,823	10-14-2003	Bartone, et al.	
	28	6,643,567	11-04-2003	Kolk et al.	
	29	6,671,586	12-30-2003	Davis, et al.	

Examiner Signature	Date Considered
<p>*Examiner: Initial if reference considered, whether or not citation is in conformance with MPEP 609. Draw line through citation if not in conformance and not considered. Include copy of this form with next communication to applicant.</p>	

T¹ - Place a check mark in this area when an English language Translation is attached.

INFORMATION DISCLOSURE STATEMENT BY APPLICANT	Application No.	Unknown
	Filing Date	Herewith
	First Named Inventor	Steinberg, John Douglas et al
	Art Unit	
<i>(Multiple sheets used when necessary)</i>		Examiner
SHEET 2 OF 4		Attorney Docket No. EFACT.007A

U.S. PATENT DOCUMENTS					
Examiner Initials	Cite No.	Document Number <i>Number - Kind Code (if known)</i> Example: 1,234,567 B1	Publication Date MM-DD-YYYY	Name of Patentee or Applicant	Pages, Columns, Lines Where Relevant Passages or Relevant Figures Appear
	30	6,695,218	02-24-2004	Fleckenstein	
	31	6,726,113	04-27-2004	Guo	
	32	6,731,992	05-04-2004	Ziegler	
	33	6,734,806	05-11-2004	Cratsley	
	34	6,772,052	08-03-2004	Amundsen	
	35	6,785,592	08-31-2004	Smith	
	36	6,785,630	08-31-2004	Kolk	
	37	6,789,739	09-14-2004	Rosen	
	38	6,853,959	02-08-2005	Ikeda, et al.	
	39	6,868,293	03-15-2005	Schurr	
	40	6,868,319	03-15-2005	Kipersztok, et al.	
	41	6,882,712	04-19-2005	Iggulden, et al.	
	42	6,889,908	05-10-2005	Crippen, et al.	
	43	6,891,838	10-10-2005	Petite, et al.	
	44	6,991,029	01-31-2006	Orfield, et al.	
	45	7,009,493	03-07-2006	Howard	
	46	7,031,880	04-18-2006	Seem, et al.	
	47	7,039,532	05-02-2006	Hunter	
	48	7,089,088	08-08-2006	Terry, et al.	
	49	7,130,719	10-31-2006	Ehlers, et al.	
	50	7,130,832	10-31-2006	Bannai, et al.	
	51	7,167,079	01-23-2007	Smyth, et al.	
	52	7,187,986	03-06-2007	Johnson, et al.	
	53	7,205,892	04-17-2007	Luebke, et al.	
	54	7,215,746	05-08-2007	Iggulden, et al.	
	55	7,216,015	05-08-2007	Poth, Robert J.	
	56	7,231,424	06-11-2007	Bodin, et al.	
	57	7,232,075	06-19-2007	Rosen	
	58	2003/0040934 A1	02-27-2003	Skidmore, et al.	

Examiner Signature	Date Considered
<p>*Examiner: Initial if reference considered, whether or not citation is in conformance with MPEP 609. Draw line through citation if not in conformance and not considered. Include copy of this form with next communication to applicant.</p>	

T¹ - Place a check mark in this area when an English language Translation is attached.

INFORMATION DISCLOSURE STATEMENT BY APPLICANT	Application No.	Unknown
	Filing Date	Herewith
	First Named Inventor	Steinberg, John Douglas et al
	Art Unit	
<i>(Multiple sheets used when necessary)</i>		Examiner
SHEET 3 OF 4		Attorney Docket No. EFACT.007A

U.S. PATENT DOCUMENTS					
Examiner Initials	Cite No.	Document Number Number - Kind Code (if known) Example: 1,234,567 B1	Publication Date MM-DD-YYYY	Name of Patentee or Applicant	Pages, Columns, Lines Where Relevant Passages or Relevant Figures Appear
	59	2005/0222889 A1	10-06-2005	Lai, et al.	
	60	2005/0288822 A1	12-29-2005	Rayburn	
	61	2007/0043477 A1	02-22-2007	Elhers, et al.	
	62	2008/0083234 A1	04-10-2008	Krebs, et al.	
	63	2009/0099699 A1	04-16-2009	Steinberg, et al.	
	64	2009/0125151 A1	05-14-2009	Steinberg, et al.	

NON PATENT LITERATURE DOCUMENTS			
Examiner Initials	Cite No.	Include name of the author (in CAPITAL LETTERS), title of the article (when appropriate), title of the item (book, magazine, journal, serial, symposium, catalog, etc.), date, page(s), volume-issue number(s), publisher, city and/or country where published.	T ¹
	65	ARENS, et al., "How Ambient Intelligence Will Improve Habitability and Energy Efficiency in Buildings", 2005, research paper, Center for the Built Environment, Controls and Information Technology	
	66	Comverge SuperStat Flyer	
	67	Control4 Wireless Thermostat Brochure	
	68	Cooper Power Systems Web Page	
	69	Enernoc Web Page	
	70	Enerwise Website	
	71	Honeywell Programmable Thermostat Owner's Guide, www.honeywell.com/yourhome	
	72	JOHNSON CONTROLS, Touch4 building automation system brochure, 2007	
	73	KILICOTTE, et al., "Dynamic Controls for Energy Efficiency and Demand Response: Framework Concepts and a New Construction Study Case in New York", Proceedings of the 2006 ACEEE Summer Study of Energy Efficiency in Buildings, Pacific Grove, CA, August 13-18, 2006	
	74	LIN, et al., "Multi-Sensor Single-Actuator Control of HVAC Systems", 2002	
	75	PIER, Southern California Edison, Demand Responsive Control of Air Conditioning via Programmable Communicating Thermostats Draft Report	
	76	Proliphix Thermostat Brochure	

Examiner Signature	Date Considered
*Examiner: Initial if reference considered, whether or not citation is in conformance with MPEP 609. Draw line through citation if not in conformance and not considered. Include copy of this form with next communication to applicant.	

T¹ - Place a check mark in this area when an English language Translation is attached.

INFORMATION DISCLOSURE STATEMENT BY APPLICANT	Application No.	Unknown
	Filing Date	Herewith
	First Named Inventor	Steinberg, John Douglas et al
	Art Unit	
<i>(Multiple sheets used when necessary)</i>	Examiner	
SHEET 4 OF 4	Attorney Docket No.	EFACT.007A

NON PATENT LITERATURE DOCUMENTS			
Examiner Initials	Cite No.	Include name of the author (in CAPITAL LETTERS), title of the article (when appropriate), title of the item (book, magazine, journal, serial, symposium, catalog, etc.), date, page(s), volume-issue number(s), publisher, city and/or country where published.	T ¹
	77	WANG, et al., "Opportunities to Save Energy and Improve Comfort by Using Wireless Sensor Networks in Buildings," (2003), Center for Environmental Design Research	
	78	WETTER, et al., "A comparison of deterministic and probabilistic optimization algorithms for nonsmooth simulation-based optimization", Building and Environment 39, 2004, Pages 989-999	

9016046:ad
050710

Examiner Signature	Date Considered
<p>*Examiner: Initial if reference considered, whether or not citation is in conformance with MPEP 609. Draw line through citation if not in conformance and not considered. Include copy of this form with next communication to applicant.</p>	

T¹ - Place a check mark in this area when an English language Translation is attached.

Electronic Acknowledgement Receipt

EFS ID:	7592432
Application Number:	12778052
International Application Number:	
Confirmation Number:	5650
Title of Invention:	SYSTEM, METHOD AND APPARATUS FOR IDENTIFYING MANUAL INPUTS TO AND ADAPTIVE PROGRAMMING OF A THERMOSTAT
First Named Inventor/Applicant Name:	John Douglas Steinberg
Customer Number:	20995
Filer:	John R. King/Valerie Jones
Filer Authorized By:	John R. King
Attorney Docket Number:	EFACT.007A
Receipt Date:	11-MAY-2010
Filing Date:	
Time Stamp:	19:54:04
Application Type:	Utility under 35 USC 111(a)

Payment information:

Submitted with Payment	no
------------------------	----

File Listing:

Document Number	Document Description	File Name	File Size(Bytes)/ Message Digest	Multi Part /.zip	Pages (if appl.)
1	NPL Documents	EFACT-007A_ref1.pdf	1381846 a6f820e33865ed89ec537d2c8ad3cc47279 12700	no	16

Warnings:

Information:

2	NPL Documents	EFACT-007A_ref2.pdf	916999	no	2
			a7bda5bc18660b04ceafcd0de01b90459586b4f3		
Warnings:					
Information:					
3	NPL Documents	EFACT-007A_ref3.pdf	1950787	no	2
			61713c4551c16c88b98addbee144306d0a260430		
Warnings:					
Information:					
4	NPL Documents	EFACT-007A_ref4.pdf	1062145	no	12
			7be62096cab2874792f027aac4fb211286a2e3f		
Warnings:					
Information:					
5	NPL Documents	EFACT-007A_ref5.pdf	585007	no	3
			024c248d78ca2a0fc62a3538b02f2d1ff3e56c78		
Warnings:					
Information:					
6	NPL Documents	EFACT-007A_ref6.pdf	146665	no	2
			bcb1be25c20ad38669ac01ec3b8a296c2801a96e		
Warnings:					
Information:					
7	NPL Documents	EFACT-007A_ref7.pdf	2407105	no	64
			77ff218ab712848ce727180579d4cfd77ff728d6		
Warnings:					
Information:					
8	NPL Documents	EFACT-007A_ref8.pdf	1032531	no	4
			07ef3d192de224d336542a7d0b3545df73cdffb1		
Warnings:					
Information:					
9	NPL Documents	EFACT-007A_ref9.pdf	1002115	no	13
			69c452ab67d7cbd0f13b9ffd39583f0f78bdccb		
Warnings:					
Information:					
10	NPL Documents	EFACT-007A_ref10.pdf	575743	no	11
			b25b99696f0ac7b9481d83a8e36564222f4b98		
Warnings:					
Information:					

11	NPL Documents	EFACT-007A_ref11.pdf	8671806 6c358183b4077c029f6a77eef33ef76fe0703c75	no	93
Warnings:					
Information:					
12	NPL Documents	EFACT-007A_ref12.pdf	886141 07c807438ddb05dd658871790cd4f3fc6e29ed4e	no	2
Warnings:					
Information:					
13	NPL Documents	EFACT-007A_ref13.pdf	709717 37730ba19090be8c07c7288fca8775cee4350e3e	no	6
Warnings:					
Information:					
14	NPL Documents	EFACT-007A_ref14.pdf	977832 02867b3b2974e982568e7e591c73cd6ea9d0c011	no	11
Warnings:					
Information:					
15	Drawings-only black and white line drawings	EFACT-007A_drawings.pdf	213773 19973bfe20d1a6e68f7bfe08dda81c7622b9df9a	no	11
Warnings:					
Information:					
16	Application Data Sheet	EFACT-007A_ads.pdf	1104428 bd8c3352cc500d835e90845a17e08720e8328ed1	no	5
Warnings:					
Information:					
17		EFACT-007A_spec.pdf	778228 fc958cbdd08326b40572e58d2ae2dd8e14f38241	yes	16
	Multipart Description/PDF files in .zip description				
	Document Description		Start	End	
	Specification		1	12	
	Claims		13	15	
Abstract		16	16		
Warnings:					
Information:					

18		EFACT-007A_IDS.pdf	255117 baa30482df1fee00223ee804c562bb9cb1598e07	yes	5
Multipart Description/PDF files in .zip description					
		Document Description	Start	End	
		Transmittal Letter	1	1	
		Information Disclosure Statement (IDS) Filed (SB/08)	2	5	
Warnings:					
Information:					
Total Files Size (in bytes):			24657985		
<p>This Acknowledgement Receipt evidences receipt on the noted date by the USPTO of the indicated documents, characterized by the applicant, and including page counts, where applicable. It serves as evidence of receipt similar to a Post Card, as described in MPEP 503.</p> <p><u>New Applications Under 35 U.S.C. 111</u> If a new application is being filed and the application includes the necessary components for a filing date (see 37 CFR 1.53(b)-(d) and MPEP 506), a Filing Receipt (37 CFR 1.54) will be issued in due course and the date shown on this Acknowledgement Receipt will establish the filing date of the application.</p> <p><u>National Stage of an International Application under 35 U.S.C. 371</u> If a timely submission to enter the national stage of an international application is compliant with the conditions of 35 U.S.C. 371 and other applicable requirements a Form PCT/DO/EO/903 indicating acceptance of the application as a national stage submission under 35 U.S.C. 371 will be issued in addition to the Filing Receipt, in due course.</p> <p><u>New International Application Filed with the USPTO as a Receiving Office</u> If a new international application is being filed and the international application includes the necessary components for an international filing date (see PCT Article 11 and MPEP 1810), a Notification of the International Application Number and of the International Filing Date (Form PCT/RO/105) will be issued in due course, subject to prescriptions concerning national security, and the date shown on this Acknowledgement Receipt will establish the international filing date of the application.</p>					

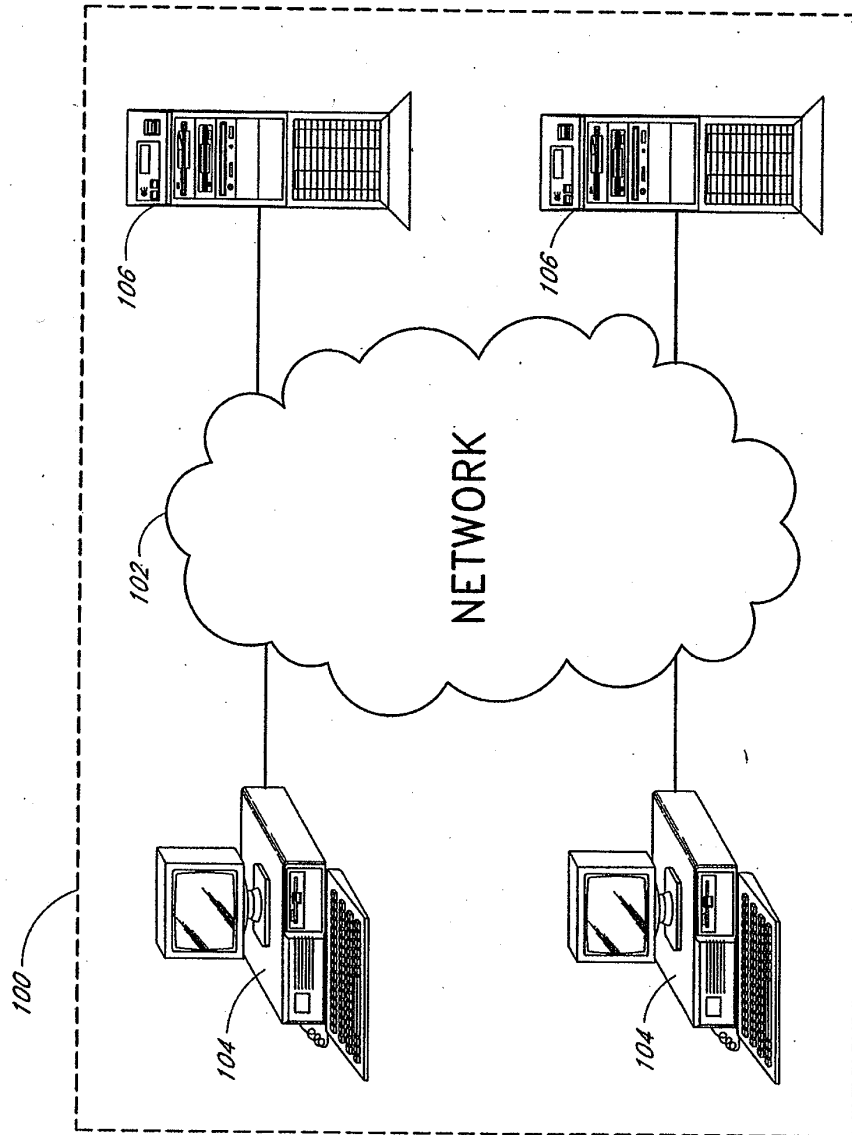

FIG. 1

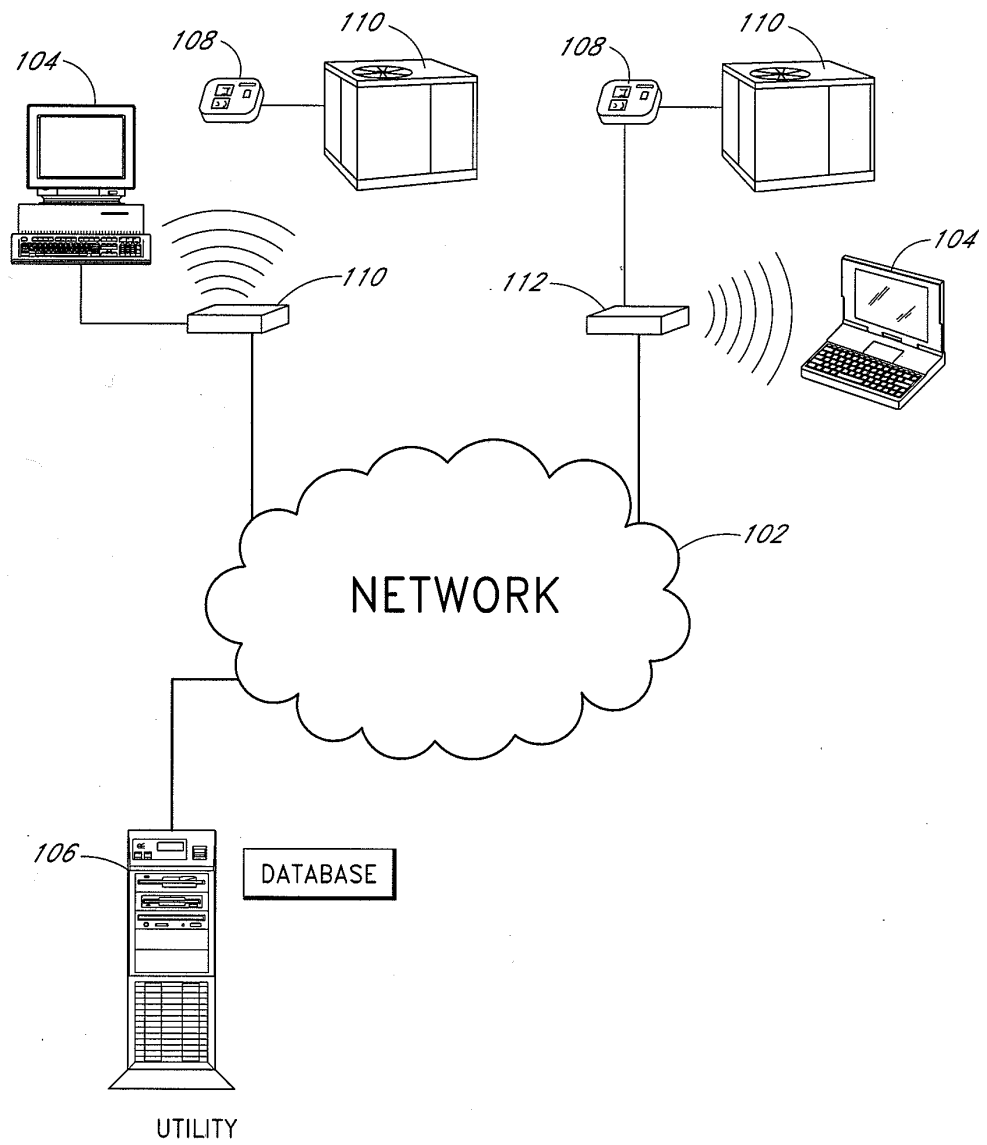

FIG. 2

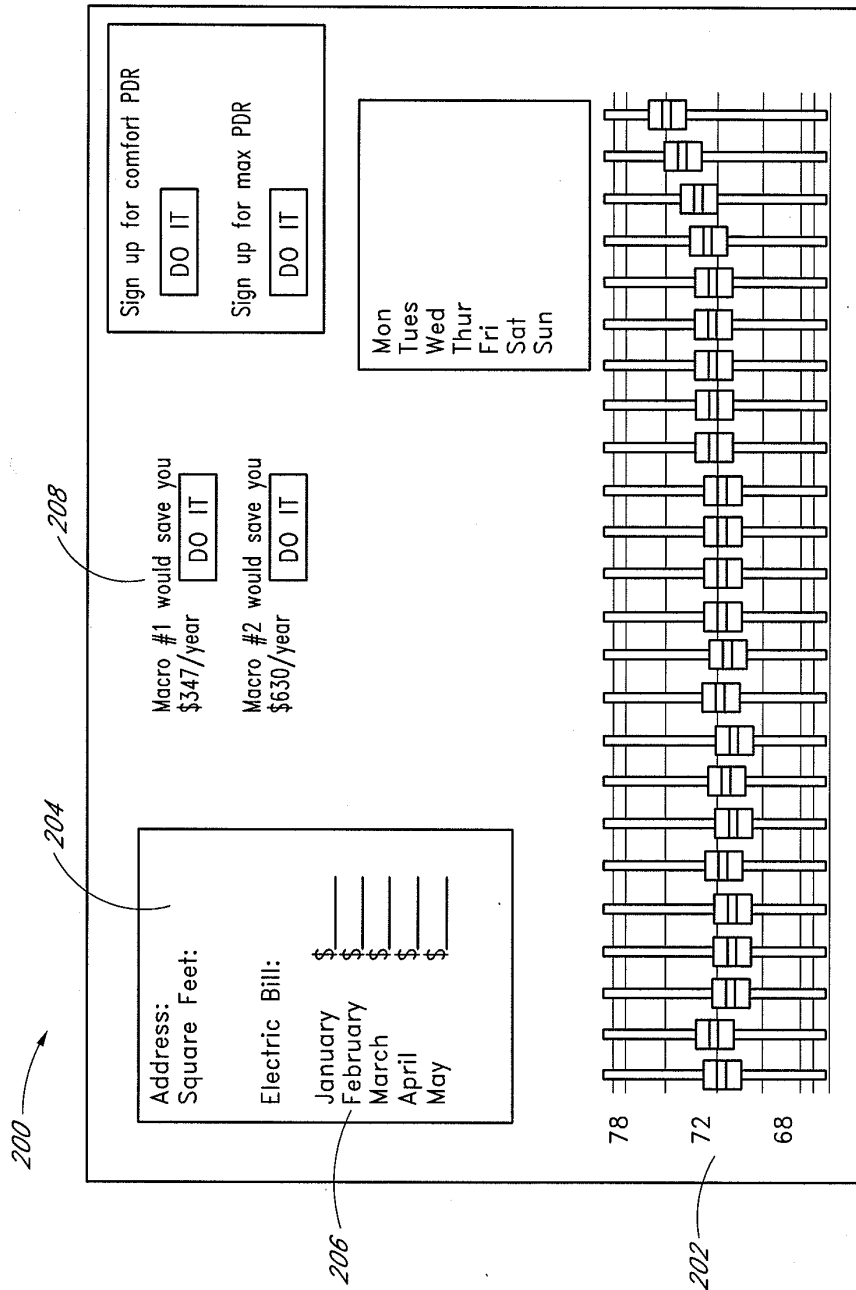

FIG. 3

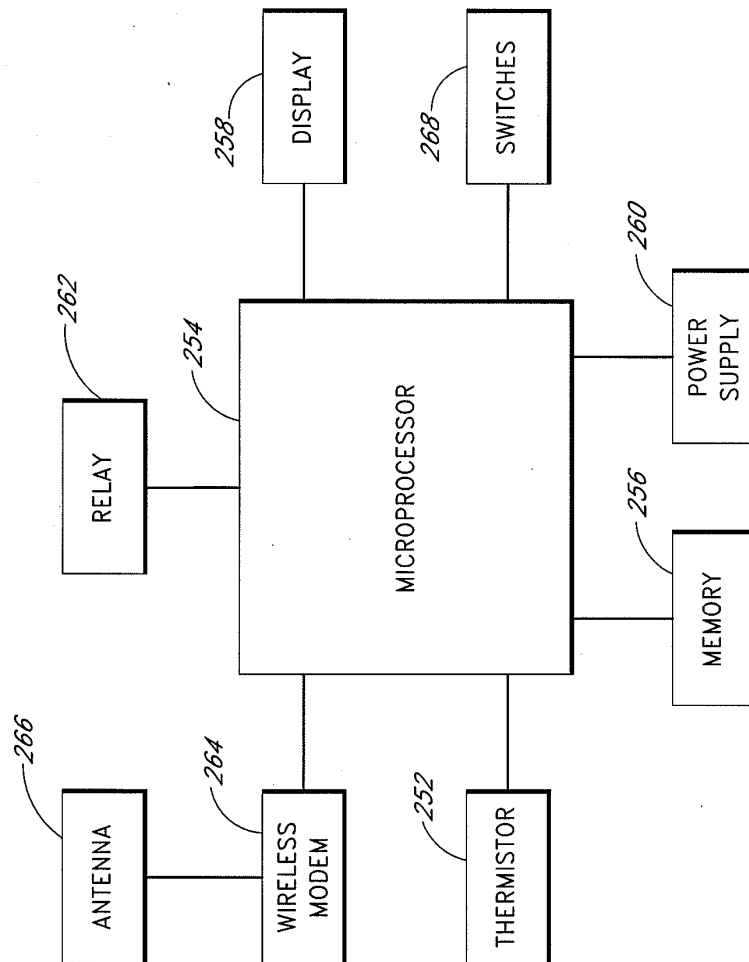

FIG. 4

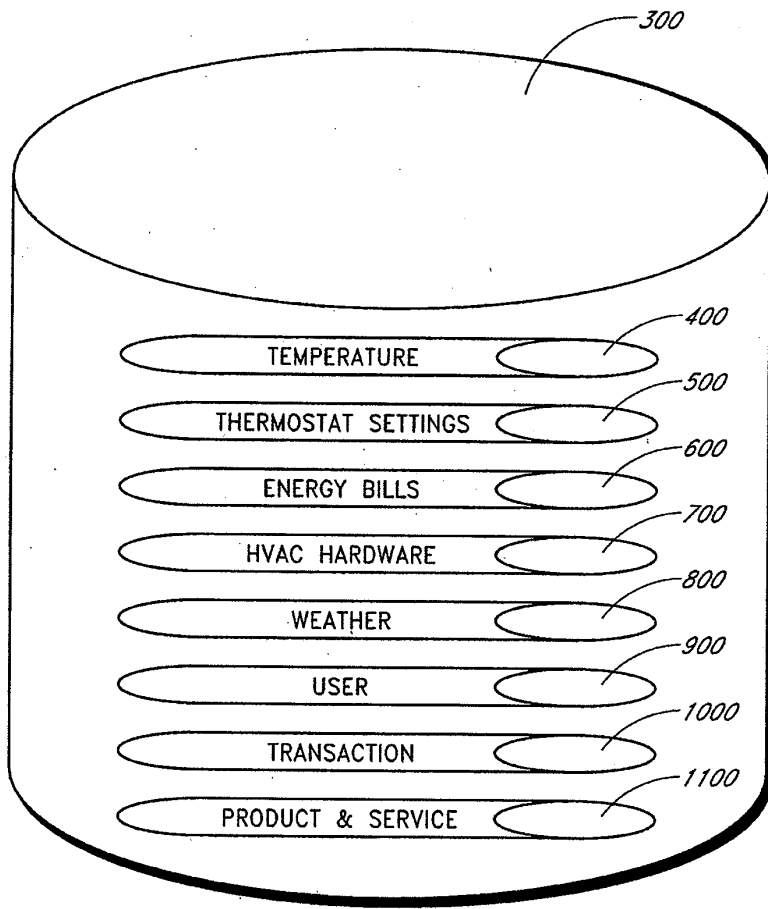

FIG. 5

FIGURE 6a

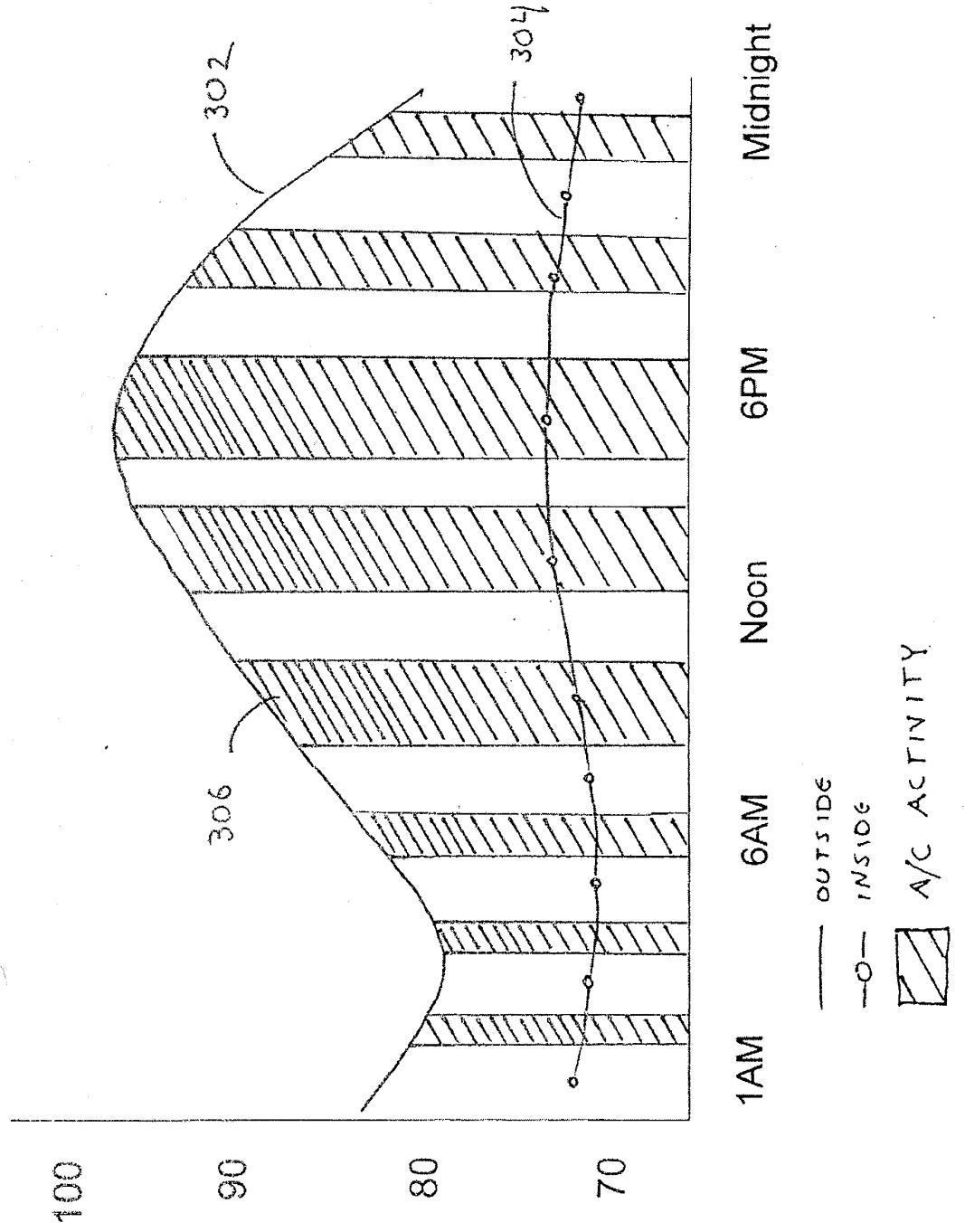

FIGURE 6b

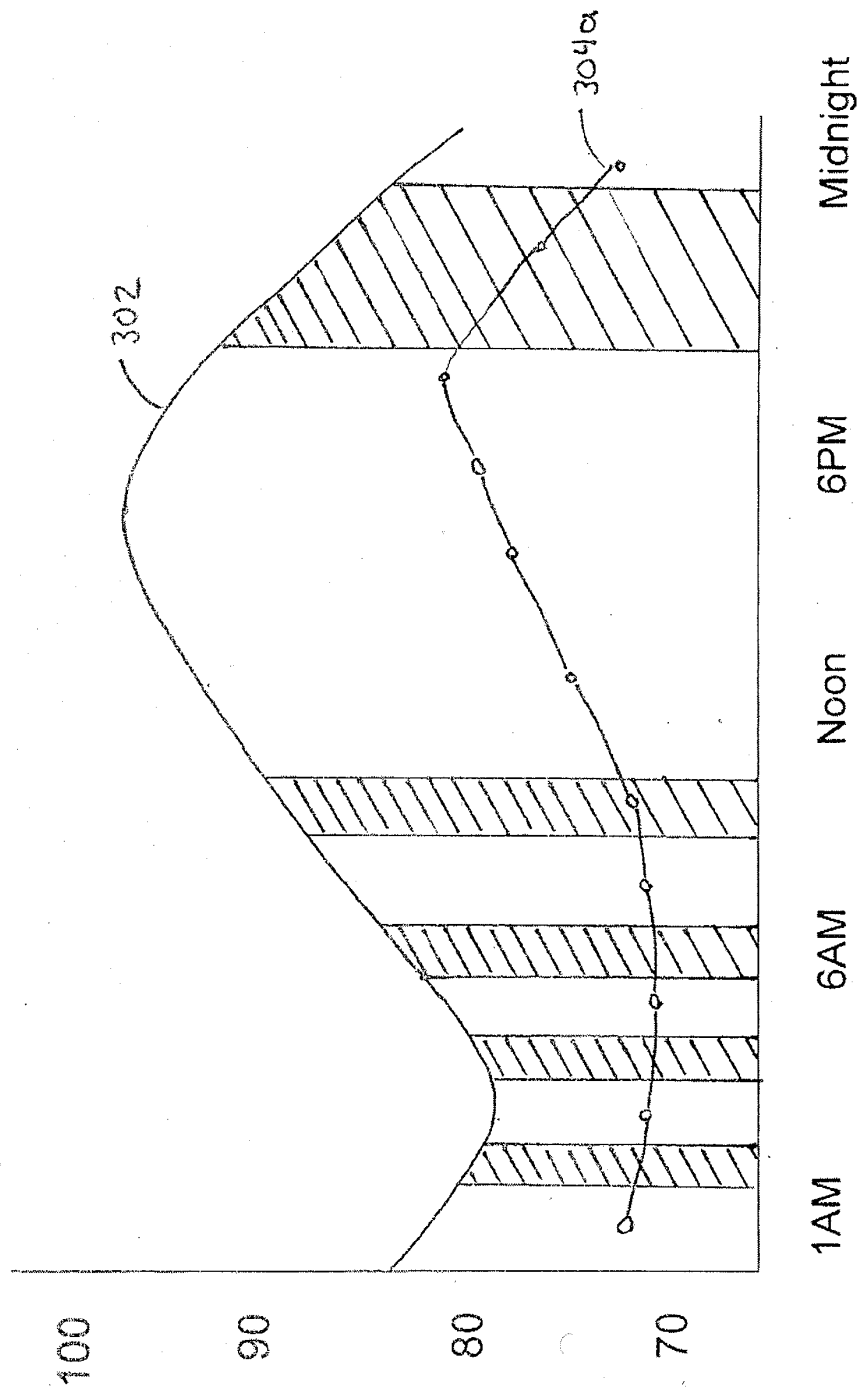

Fig 7

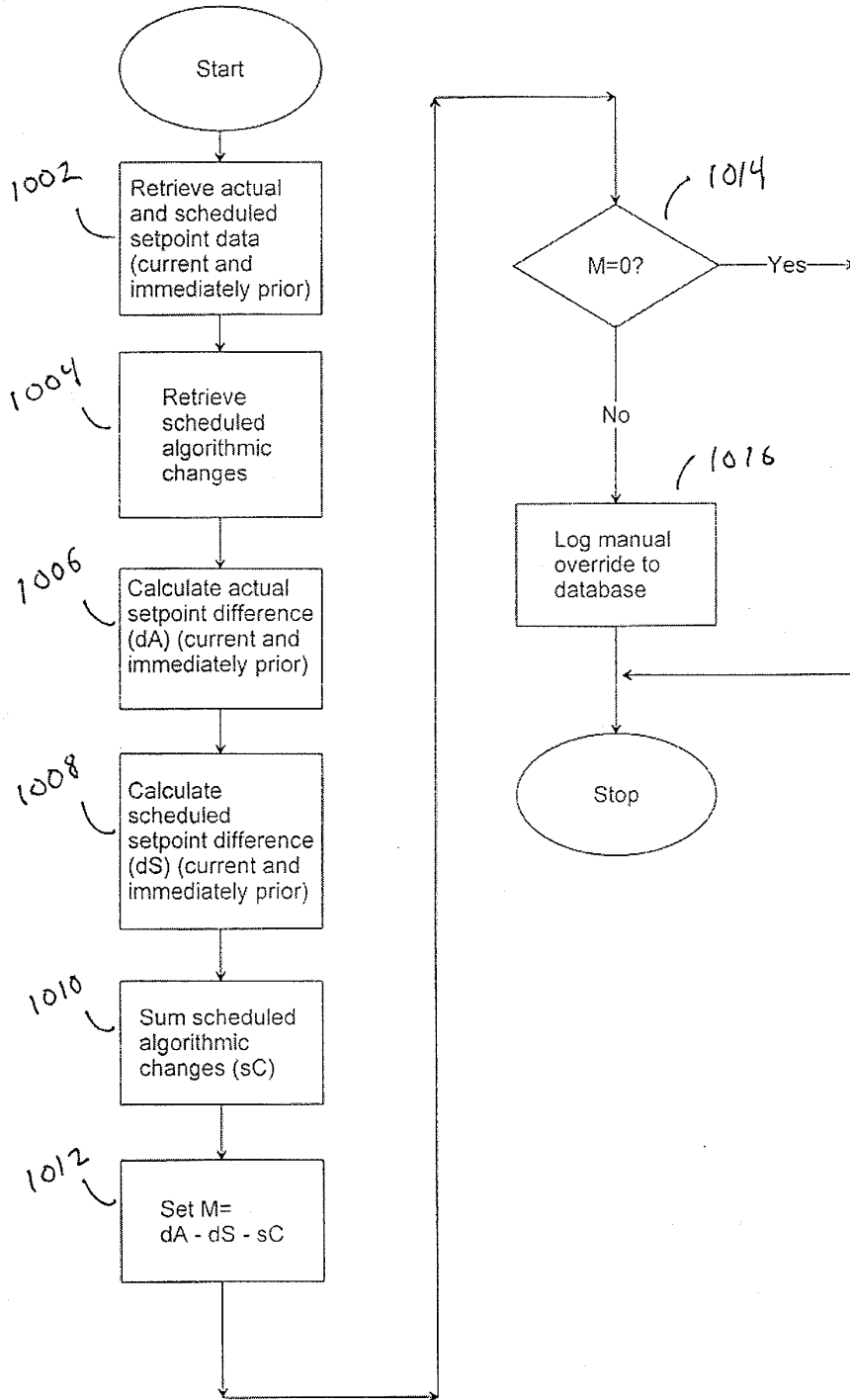

Figure 8

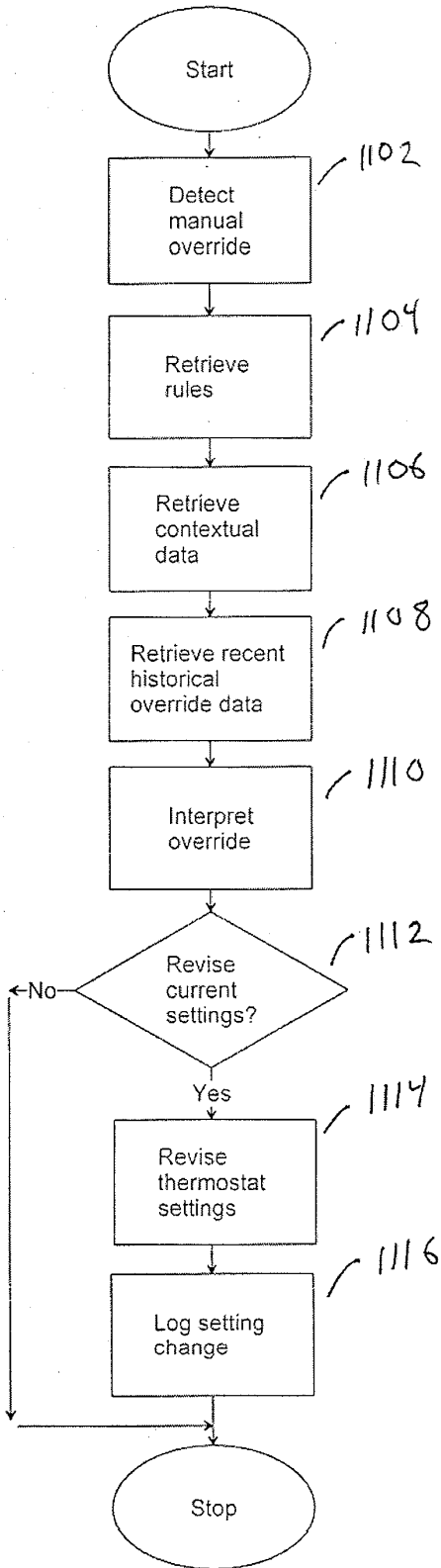

Figure 9

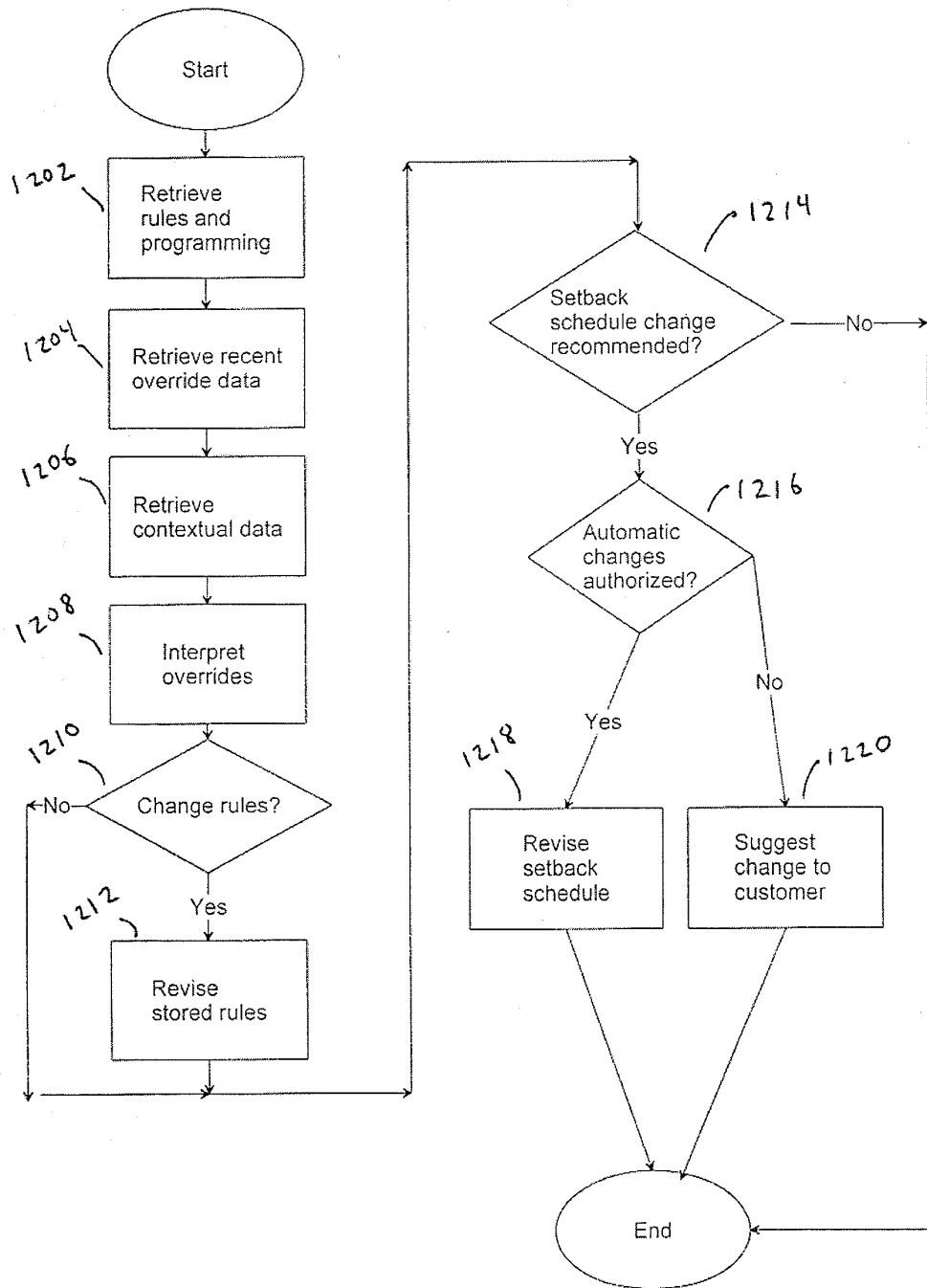

Fig. 10

Time	Temperature		Humidity	Wind	Wind Dir	Wind Speed	Wind Gust	Control Mode				Heat	Cool
	Indoor	Outdoor						Mode	Setpoint	Actual	Setpoint		
2009/04/10 11:00	68.70	54.00	74%	29.89m / 1012.1hPa (Steady)	SE	1.0mph / 1.6km/h	0.0	Off	Off/Day	60.00	65.00	Heat	Heat
2009/04/10 11:01	69.00	54.10	74%	29.89m / 1012.1hPa (Rising)	SE	2.0mph / 3.2km/h	0.0	Off	Off/Day	60.00	65.00	Heat	Heat
2009/04/10 11:02	69.60	54.10	74%	29.89m / 1012.1hPa (Rising)	SE	2.0mph / 3.2km/h	0.0	Off	Off/Day	60.00	65.00	Heat	Heat
2009/04/10 11:03	69.70	54.10	74%	29.89m / 1012.1hPa (Rising)	SE	2.0mph / 3.2km/h	0.0	Off	Off/Day	60.00	65.00	Heat	Heat
2009/04/10 11:04	69.70	54.10	73%	29.89m / 1012.1hPa (Rising)	SE	2.0mph / 3.2km/h	0.0	Off	Off/Day	60.00	65.00	Heat	Heat
2009/04/10 11:05	69.70	54.10	74%	29.89m / 1012.1hPa (Rising)	SE	2.0mph / 3.2km/h	0.0	Off	Off/Day	60.00	65.00	Heat	Heat
2009/04/10 11:05	69.80	54.70	72%	29.89m / 1012.1hPa (Rising)	SE	2.0mph / 3.2km/h	0.0	Off	Off/Day	60.00	65.00	Heat	Heat
2009/04/10 11:07	69.80	54.70	72%	29.89m / 1012.1hPa (Rising)	SE	2.0mph / 3.2km/h	0.0	Off	Off/Day	60.00	65.00	Heat	Heat
2009/04/10 11:08	70.30	54.70	72%	29.89m / 1012.1hPa (Rising)	SE	2.0mph / 3.2km/h	0.0	Off	Off/Day	60.00	65.00	Heat	Heat
2009/04/10 11:09	70.00	54.70	72%	29.89m / 1012.1hPa (Rising)	SE	2.0mph / 3.2km/h	0.0	Off	Off/Day	60.00	65.00	Heat	Heat
2009/04/10 11:10	70.00	54.70	72%	29.89m / 1012.1hPa (Rising)	SE	2.0mph / 3.2km/h	0.0	Off	Off/Day	60.00	65.00	Heat	Heat

Under the Paperwork Reduction Act of 1995, no persons are required to respond to a collection of information unless it contains a valid OMB control number.

Application Data Sheet 37 CFR 1.76		Attorney Docket Number	EFACT.007A
		Application Number	
Title of Invention	SYSTEM, METHOD AND APPARATUS FOR IDENTIFYING MANUAL INPUTS TO AND ADAPTIVE PROGRAMMING OF A THERMOSTAT		
The application data sheet is part of the provisional or nonprovisional application for which it is being submitted. The following form contains the bibliographic data arranged in a format specified by the United States Patent and Trademark Office as outlined in 37 CFR 1.76. This document may be completed electronically and submitted to the Office in electronic format using the Electronic Filing System (EFS) or the document may be printed and included in a paper filed application.			

Secrecy Order 37 CFR 5.2

Portions or all of the application associated with this Application Data Sheet may fall under a Secrecy Order pursuant to 37 CFR 5.2 (Paper filers only. Applications that fall under Secrecy Order may not be filed electronically.)

Applicant Information:

Applicant 1						Remove
Applicant Authority		<input checked="" type="radio"/> Inventor		<input type="radio"/> Legal Representative under 35 U.S.C. 117		<input type="radio"/> Party of Interest under 35 U.S.C. 118
Prefix	Given Name	Middle Name	Family Name	Suffix		
	John	Douglas	Steinberg			
Residence Information (Select One)						
		<input checked="" type="radio"/> US Residency		<input type="radio"/> Non US Residency		<input type="radio"/> Active US Military Service
City	Millbrae	State/Province	CA	Country of Residence i	US	
Citizenship under 37 CFR 1.41(b) i		US				
Mailing Address of Applicant:						
Address 1						
Address 2						
City				State/Province		
Postal Code			Countryⁱ			
Applicant 2						Remove
Applicant Authority		<input checked="" type="radio"/> Inventor		<input type="radio"/> Legal Representative under 35 U.S.C. 117		<input type="radio"/> Party of Interest under 35 U.S.C. 118
Prefix	Given Name	Middle Name	Family Name	Suffix		
	Scott	Douglas	Hublou			
Residence Information (Select One)						
		<input checked="" type="radio"/> US Residency		<input type="radio"/> Non US Residency		<input type="radio"/> Active US Military Service
City	Redwood City	State/Province	CA	Country of Residence i	US	
Citizenship under 37 CFR 1.41(b) i		US				
Mailing Address of Applicant:						
Address 1						
Address 2						
City				State/Province		
Postal Code			Countryⁱ			
Applicant 3						Remove
Applicant Authority		<input checked="" type="radio"/> Inventor		<input type="radio"/> Legal Representative under 35 U.S.C. 117		<input type="radio"/> Party of Interest under 35 U.S.C. 118
Prefix	Given Name	Middle Name	Family Name	Suffix		
	Leo		Cheung			
Residence Information (Select One)						
		<input checked="" type="radio"/> US Residency		<input type="radio"/> Non US Residency		<input type="radio"/> Active US Military Service
City	Sunnyvale	State/Province	CA	Country of Residence i	US	

Under the Paperwork Reduction Act of 1995, no persons are required to respond to a collection of information unless it contains a valid OMB control number.

Application Data Sheet 37 CFR 1.76		Attorney Docket Number	EFACT.007A
		Application Number	
Title of Invention	SYSTEM, METHOD AND APPARATUS FOR IDENTIFYING MANUAL INPUTS TO AND ADAPTIVE PROGRAMMING OF A THERMOSTAT		

Citizenship under 37 CFR 1.41(b) i	US		
Mailing Address of Applicant:			
Address 1			
Address 2			
City		State/Province	
Postal Code		Country	
All Inventors Must Be Listed - Additional Inventor Information blocks may be generated within this form by selecting the Add button.			<input type="button" value="Add"/>

Correspondence Information:

Enter either Customer Number or complete the Correspondence Information section below. For further information see 37 CFR 1.33(a).			
<input type="checkbox"/> An Address is being provided for the correspondence information of this application.			
Customer Number	20995		
Email Address	efiling@kmob.com	<input type="button" value="Add Email"/>	<input type="button" value="Remove Email"/>

Application Information:

Title of the Invention	SYSTEM, METHOD AND APPARATUS FOR IDENTIFYING MANUAL INPUTS TO AND ADAPTIVE PROGRAMMING OF A THERMOSTAT		
Attorney Docket Number	EFACT.007A	Small Entity Status Claimed	<input checked="" type="checkbox"/>
Application Type	Nonprovisional		
Subject Matter	Utility		
Suggested Class (if any)		Sub Class (if any)	
Suggested Technology Center (if any)			
Total Number of Drawing Sheets (if any)	11	Suggested Figure for Publication (if any)	

Publication Information:

<input type="checkbox"/> Request Early Publication (Fee required at time of Request 37 CFR 1.219)
<input type="checkbox"/> Request Not to Publish. I hereby request that the attached application not be published under 35 U.S.C. 122(b) and certify that the invention disclosed in the attached application has not and will not be the subject of an application filed in another country, or under a multilateral international agreement, that requires publication at eighteen months after filing.

Representative Information:

Representative information should be provided for all practitioners having a power of attorney in the application. Providing this information in the Application Data Sheet does not constitute a power of attorney in the application (see 37 CFR 1.32). Enter either Customer Number or complete the Representative Name section below. If both sections are completed the Customer Number will be used for the Representative Information during processing.			
Please Select One:	<input checked="" type="radio"/> Customer Number	<input type="radio"/> US Patent Practitioner	<input type="radio"/> Limited Recognition (37 CFR 11.9)

Under the Paperwork Reduction Act of 1995, no persons are required to respond to a collection of information unless it contains a valid OMB control number.

Application Data Sheet 37 CFR 1.76		Attorney Docket Number	EFACT.007A
		Application Number	
Title of Invention	SYSTEM, METHOD AND APPARATUS FOR IDENTIFYING MANUAL INPUTS TO AND ADAPTIVE PROGRAMMING OF A THERMOSTAT		
Customer Number	20995		

Domestic Benefit/National Stage Information:

This section allows for the applicant to either claim benefit under 35 U.S.C. 119(e), 120, 121, or 365(c) or indicate National Stage entry from a PCT application. Providing this information in the application data sheet constitutes the specific reference required by 35 U.S.C. 119(e) or 120, and 37 CFR 1.78(a)(2) or CFR 1.78(a)(4), and need not otherwise be made part of the specification.

Prior Application Status	Pending	Remove	
Application Number	Continuity Type	Prior Application Number	Filing Date (YYYY-MM-DD)
	non provisional of	61215999	2009-05-12
Additional Domestic Benefit/National Stage Data may be generated within this form by selecting the Add button.			Add

Foreign Priority Information:

This section allows for the applicant to claim benefit of foreign priority and to identify any prior foreign application for which priority is not claimed. Providing this information in the application data sheet constitutes the claim for priority as required by 35 U.S.C. 119(b) and 37 CFR 1.55(a).

Remove			
Application Number	Country ⁱ	Parent Filing Date (YYYY-MM-DD)	Priority Claimed
			<input type="radio"/> Yes <input checked="" type="radio"/> No
Additional Foreign Priority Data may be generated within this form by selecting the Add button.			Add

Assignee Information:

Providing this information in the application data sheet does not substitute for compliance with any requirement of part 3 of Title 37 of the CFR to have an assignment recorded in the Office.

Assignee 1				Remove
If the Assignee is an Organization check here. <input checked="" type="checkbox"/>				
Organization Name	EcoFactor, Inc.			
Mailing Address Information:				
Address 1	423 Broadway, #801			
Address 2				
City	Millbrae	State/Province	CA	
Country ⁱ	US	Postal Code	94030	
Phone Number		Fax Number		
Email Address				
Additional Assignee Data may be generated within this form by selecting the Add button.				Add

Signature:

A signature of the applicant or representative is required in accordance with 37 CFR 1.33 and 10.18. Please see 37 CFR 1.4(d) for the form of the signature.

Under the Paperwork Reduction Act of 1995, no persons are required to respond to a collection of information unless it contains a valid OMB control number.

Application Data Sheet 37 CFR 1.76		Attorney Docket Number		EFACT.007A	
		Application Number			
Title of Invention		SYSTEM, METHOD AND APPARATUS FOR IDENTIFYING MANUAL INPUTS TO AND ADAPTIVE PROGRAMMING OF A THERMOSTAT			
Signature		/John R. King/		Date (YYYY-MM-DD)	
				2010-05-11	
First Name	John	Last Name	King	Registration Number	34362

This collection of information is required by 37 CFR 1.76. The information is required to obtain or retain a benefit by the public which is to file (and by the USPTO to process) an application. Confidentiality is governed by 35 U.S.C. 122 and 37 CFR 1.14. This collection is estimated to take 23 minutes to complete, including gathering, preparing, and submitting the completed application data sheet form to the USPTO. Time will vary depending upon the individual case. Any comments on the amount of time you require to complete this form and/or suggestions for reducing this burden, should be sent to the Chief Information Officer, U.S. Patent and Trademark Office, U.S. Department of Commerce, P.O. Box 1450, Alexandria, VA 22313-1450. DO NOT SEND FEES OR COMPLETED FORMS TO THIS ADDRESS. **SEND TO: Commissioner for Patents, P.O. Box 1450, Alexandria, VA 22313-1450.**

Privacy Act Statement

The Privacy Act of 1974 (P.L. 93-579) requires that you be given certain information in connection with your submission of the attached form related to a patent application or patent. Accordingly, pursuant to the requirements of the Act, please be advised that: (1) the general authority for the collection of this information is 35 U.S.C. 2(b)(2); (2) furnishing of the information solicited is voluntary; and (3) the principal purpose for which the information is used by the U.S. Patent and Trademark Office is to process and/or examine your submission related to a patent application or patent. If you do not furnish the requested information, the U.S. Patent and Trademark Office may not be able to process and/or examine your submission, which may result in termination of proceedings or abandonment of the application or expiration of the patent.

The information provided by you in this form will be subject to the following routine uses:

1. The information on this form will be treated confidentially to the extent allowed under the Freedom of Information Act (5 U.S.C. 552) and the Privacy Act (5 U.S.C. 552a). Records from this system of records may be disclosed to the Department of Justice to determine whether the Freedom of Information Act requires disclosure of these records.
2. A record from this system of records may be disclosed, as a routine use, in the course of presenting evidence to a court, magistrate, or administrative tribunal, including disclosures to opposing counsel in the course of settlement negotiations.
3. A record in this system of records may be disclosed, as a routine use, to a Member of Congress submitting a request involving an individual, to whom the record pertains, when the individual has requested assistance from the Member with respect to the subject matter of the record.
4. A record in this system of records may be disclosed, as a routine use, to a contractor of the Agency having need for the information in order to perform a contract. Recipients of information shall be required to comply with the requirements of the Privacy Act of 1974, as amended, pursuant to 5 U.S.C. 552a(m).
5. A record related to an International Application filed under the Patent Cooperation Treaty in this system of records may be disclosed, as a routine use, to the International Bureau of the World Intellectual Property Organization, pursuant to the Patent Cooperation Treaty.
6. A record in this system of records may be disclosed, as a routine use, to another federal agency for purposes of National Security review (35 U.S.C. 181) and for review pursuant to the Atomic Energy Act (42 U.S.C. 218(c)).
7. A record from this system of records may be disclosed, as a routine use, to the Administrator, General Services, or his/her designee, during an inspection of records conducted by GSA as part of that agency's responsibility to recommend improvements in records management practices and programs, under authority of 44 U.S.C. 2904 and 2906. Such disclosure shall be made in accordance with the GSA regulations governing inspection of records for this purpose, and any other relevant (i.e., GSA or Commerce) directive. Such disclosure shall not be used to make determinations about individuals.
8. A record from this system of records may be disclosed, as a routine use, to the public after either publication of the application pursuant to 35 U.S.C. 122(b) or issuance of a patent pursuant to 35 U.S.C. 151. Further, a record may be disclosed, subject to the limitations of 37 CFR 1.14, as a routine use, to the public if the record was filed in an application which became abandoned or in which the proceedings were terminated and which application is referenced by either a published application, an application open to public inspections or an issued patent.
9. A record from this system of records may be disclosed, as a routine use, to a Federal, State, or local law enforcement agency, if the USPTO becomes aware of a violation or potential violation of law or regulation.

SYSTEM, METHOD AND APPARATUS FOR IDENTIFYING MANUAL INPUTS TO
AND ADAPTIVE PROGRAMMING OF A THERMOSTAT

CROSS-REFERENCE TO RELATED APPLICATIONS

[0001] This application claims priority to Provisional Application Number 61/215,999, filed May 12, 2009, the entirety of which is incorporated herein by reference and is to be considered part of this specification.

BACKGROUND OF THE INVENTION

Field of the Invention

[0002] Programmable thermostats have been available for more than 20 years. Programmable thermostats offer two types of advantages as compared to non-programmable devices. On the one hand, programmable thermostats can save energy in large part because they automate the process of reducing conditioning during times when the space is unoccupied, or while occupants are sleeping, and thus reduce energy consumption.

[0003] On the other hand, programmable thermostats can also enhance comfort as compared to manually changing setpoints using a non-programmable thermostat. For example, during the winter, a homeowner might manually turn down the thermostat from 70 degrees F to 64 degrees when going to sleep and back to 70 degrees in the morning. The drawback to this approach is that there can be considerable delay between the adjustment of the thermostat and the achieving of the desired change in ambient temperature, and many people find getting out of bed, showering, etc. in a cold house unpleasant. A programmable thermostat allows homeowners to anticipate the desired result by programming a pre-conditioning of the home. So, for example, if the homeowner gets out of bed at 7AM, setting the thermostat to change from the overnight setpoint of 64 degrees to 70 at 6AM can make the house comfortable when the consumer gets up. The drawback to this approach is that the higher temperature will cost more to maintain, so the increase in comfort is purchased at the cost of higher energy usage.

[0004] But all of the advantages of a programmable thermostat depend on the match between the preferences of the occupants and the actual settings employed. If, for

example, the thermostat is set to warm up the house on winter mornings at 7AM, but the homeowner gets up at 5:30, the homeowner is likely to be dissatisfied. If a homeowner has programmed her thermostat to cool down the house at 5PM each afternoon based on the assumption that she will come home at 6PM, but her schedule changes and she begins to arrive home at 4:30 each day, she is likely to be uncomfortable and either make frequent manual changes or go through the generally non-intuitive process of reprogramming the thermostat to match her new schedule. Because the limited interface on most thermostats, that process may take considerable effort, which leads many users to avoid reprogramming their thermostats for long periods or even to skip doing so entirely.

[0005] But even if a homeowner is able to align her schedule with the programming of her thermostat, there are additional difficulties associated with choosing proper temperatures at those times. If the temperatures programmed into a thermostat do not accurately reflect the preferences of the occupants, those occupants are likely to resort to manual overrides of the programmed settings. The need to correct the “mistakes” of the thermostat is likely to annoy many users. And because people tend to overshoot the desired temperature when they make such manual changes, these overrides are likely to result in excessive heating and cooling, and thus unnecessary energy use. That is, if a person feels uncomfortable on a summer afternoon when the setting is 73 degrees, they are likely to change it to 68 or 69 rather than 71 or 72 degrees, even if 72 degrees might have made enough of a difference.

[0006] It would therefore be advantageous to have a means for adapting to signaling from occupants in the form of manual temperature changes and incorporating the information contained in such gestures into long-term programming. It would also be desirable to take into account both outside weather conditions and the thermal characteristics of individual homes in order to improve the ability to dynamically achieve the best possible balance between comfort and energy savings.

BRIEF DESCRIPTION OF THE DRAWINGS

[0007] Figure 1 shows an example of an overall environment in which an embodiment of the invention may be used.

[0008] Figure 2 shows a high-level illustration of the architecture of a network showing the relationship between the major elements of one embodiment of the subject invention.

[0009] Figure 3 shows an embodiment of the website to be used as part of the subject invention.

[0010] Figure 4 shows a high-level schematic of the thermostat used as part of the subject invention.

[0011] Figure 5 shows one embodiment of the database structure used as part of the subject invention.

[0012] Figure 6 shows how comparing inside temperature against outside temperature and other variables permits calculation of dynamic signatures.

[0013] Figure 7 shows how manual inputs can be recognized and recorded by the subject invention.

[0014] Figure 8 shows how the subject invention uses manual inputs to interpret manual overrides and make short-term changes in response thereto.

[0015] Figure 9 shows how the subject invention uses manual inputs to alter long-term changes to interpretive rules and to setpoint scheduling.

DETAILED DESCRIPTION OF THE PREFERRED EMBODIMENT

[0016] **Figure 1** shows an example of an overall environment 100 in which an embodiment of the invention may be used. The environment 100 includes an interactive communication network 102 with computers 104 connected thereto. Also connected to network 102 are one or more server computers 106, which store information and make the information available to computers 104. The network 102 allows communication between and among the computers 104 and 106.

[0017] Presently preferred network 102 comprises a collection of interconnected public and/or private networks that are linked to together by a set of standard protocols to form a distributed network. While network 102 is intended to refer to what is now commonly referred to as the Internet, it is also intended to encompass variations which may be made in the future, including changes additions to existing standard protocols.

[0018] One popular part of the Internet is the World Wide Web. The World Wide Web contains a large number of computers 104 and servers 106, which store HyperText Markup Language (HTML) and other documents capable of displaying graphical and textual information. HTML is a standard coding convention and set of codes for attaching presentation and linking attributes to informational content within documents.

[0019] The servers 106 that provide offerings on the World Wide Web are typically called websites. A website is often defined by an Internet address that has an associated electronic page. Generally, an electronic page is a document that organizes the presentation of text graphical images, audio and video.

[0020] In addition to the Internet, the network 102 can comprise a wide variety of interactive communication media. For example, network 102 can include local area networks, interactive television networks, telephone networks, wireless data systems, two-way cable systems, and the like.

[0021] Network 102 can also comprise servers 106 that provide services other than HTML documents. Such services may include the exchange of data with a wide variety of "edge" devices, some of which may not be capable of displaying web pages, but that can record, transmit and receive information.

[0022] In one embodiment, computers 104 and servers 106 are conventional computers that are equipped with communications hardware such as modem or a network interface card. The computers include processors such as those sold by Intel and AMD. Other processors may also be used, including general-purpose processors, multi-chip processors, embedded processors and the like.

[0023] Computers 104 can also be handheld and wireless devices such as personal digital assistants (PDAs), cellular telephones and other devices capable of accessing the network.

[0024] Computers 104 may utilize a browser configured to interact with the World Wide Web. Such browsers may include Microsoft Explorer, Mozilla, Firefox, Opera or Safari. They may also include browsers used on handheld and wireless devices.

[0025] The storage medium may comprise any method of storing information. It may comprise random access memory (RAM), electronically erasable programmable read only memory (EEPROM), read only memory (ROM), hard disk, floppy disk, CD-ROM, optical memory, or other method of storing data.

[0026] Computers 104 and 106 may use an operating system such as Microsoft Windows, Apple Mac OS, Linux, Unix or the like.

[0027] Computers 106 may include a range of devices that provide information, sound, graphics and text, and may use a variety of operating systems and software optimized for distribution of content via networks.

[0028] **Figure 2** illustrates in further detail the architecture of the specific components connected to network 102 showing the relationship between the major elements of one embodiment of the subject invention. Attached to the network are thermostats 108 and computers 104 of various users. Connected to thermostats 108 are HVAC units 110. The HVAC units may be conventional air conditioners, heat pumps, or other devices for transferring heat into or out of a building. Each user may be connected to server 106 via wired or wireless connection such as Ethernet or a wireless protocol such as IEEE 802.11, and router and/or gateway or wireless access point 112 that connects the computer and thermostat to the Internet via a broadband connection such as a digital subscriber line (DSL) or other form of broadband connection to the World Wide Web. In one embodiment, thermostat management server 106 is in communication with the network 102. Server 106 contains the content to be served as web pages and viewed by computers 104, as well as databases containing information used by the servers, and applications used to remotely manage thermostats 108.

[0029] In the currently preferred embodiment, the website 200 includes a number of components accessible to the user, as shown in **Figure 3**. Those components may include a means to store temperature settings 202, a means to enter information about the user's home 204, a means to enter the user's electricity bills 206, and means to elect to enable the subject invention 208.

[0030] **Figure 4** shows a high-level block diagram of thermostat 108 used as part of the subject invention. Thermostat 108 includes temperature sensing means 252, which

may be a thermistor, thermal diode or other means commonly used in the design of electronic thermostats. It includes a microprocessor 254, memory 256, a display 258, a power source 260, and at least one relay 262, which turns the HVAC system on and off in response to a signal from the microprocessor, and contacts by which the relay is connected to the wires that lead to the HVAC system. To allow the thermostat to communicate bi-directionally with the computer network, the thermostat also includes means 264 to connect the thermostat to a local computer or to a wired or wireless network. Such means could be in the form of Ethernet, wireless protocols such as IEEE 802.11, IEEE 802.15.4, Bluetooth, or other wireless protocols. The thermostat may be connected to the computer network directly via wired or wireless Internet Protocol connection. Alternatively, the thermostat may connect wirelessly to a gateway such as an IP-to-Zigbee gateway, an IP-to-Z-wave gateway, or the like. Where the communications means enabled include wireless communication, antenna 266 will also be included. The thermostat 250 may also include controls 268 allowing users to change settings directly at the thermostat, but such controls are not necessary to allow the thermostat to function.

[0031] The data used to generate the content delivered in the form of the website and to automate control of thermostat 108 is stored on one or more servers 106 within one or more databases. As shown in **Figure 5**, the overall database structure 300 may include temperature database 400, thermostat settings database 500, energy bill database 600, HVAC hardware database 700, weather database 800, user database 900, transaction database 1000, product and service database 1100 and such other databases as may be needed to support these and additional features.

[0032] The website will allow users of connected thermostats 108 to create personal accounts. Each user's account will store information in database 900, which tracks various attributes relative to users. Such attributes may include the make and model of the specific HVAC equipment in the user's home; the age and square footage of the home, the solar orientation of the home, the location of the thermostat in the home, the user's preferred temperature settings, etc.

[0033] As shown in Figure 3, the website 200 will permit thermostat users to perform through the web browser substantially all of the programming functions traditionally performed directly at the physical thermostat, such as temperature set points, the time at which the thermostat should be at each set point, etc. Preferably the website will also allow users to accomplish more advanced tasks such as allow users to program in vacation settings for times when the HVAC system may be turned off or run at more economical settings, and set macros that will allow changing the settings of the temperature for all periods with a single gesture such as a mouse click.

[0034] In addition to using the system to allow better signaling and control of the HVAC system, which relies primarily on communication running from the server to the thermostat, the bi-directional communication will also allow the thermostat 108 to regularly measure and send to the server information about the temperature in the building. By comparing outside temperature, inside temperature, thermostat settings, cycling behavior of the HVAC system, and other variables, the system will be capable of numerous diagnostic and controlling functions beyond those of a standard thermostat.

[0035] For example, **Fig. 6a** shows a graph of inside temperature, outside temperature and HVAC activity for a 24-hour period. When outside temperature 302 increases, inside temperature 304 follows, but with some delay because of the thermal mass of the building, unless the air conditioning 306 operates to counteract this effect. When the air conditioning turns on, the inside temperature stays constant (or rises at a much lower rate or even falls) despite the rising outside temperature. In this example, frequent and heavy use of the air conditioning results in only a very slight temperature increase inside the house of 4 degrees, from 72 to 76 degrees, despite the increase in outside temperature from 80 to 100 degrees.

[0036] **Figure 6b** shows a graph of the same house on the same day, but assumes that the air conditioning is turned off from noon to 7PM. As expected, the inside temperature 304a rises with increasing outside temperatures 302 for most of that period, reaching 88 degrees at 7PM. Because server 106 logs the temperature readings from inside each house (whether once per minute or over some other interval), as well as the timing and duration of air conditioning cycles, database 300 will contain a history of the thermal performance of

each house. That performance data will allow server 106 to calculate an effective thermal mass for each such structure – that is, the speed with the temperature inside a given building will change in response to changes in outside temperature. Because the server will also log these inputs against other inputs including time of day, humidity, etc. the server will be able to predict, at any given time on any given day, the rate at which inside temperature should change for given inside and outside temperatures.

[0037] The ability to predict the rate of change in inside temperature in a given house under varying conditions may be applied by in effect holding the desired future inside temperature as a constraint and using the ability to predict the rate of change to determine when the HVAC system must be turned on in order to reach the desired temperature at the desired time.

[0038] In order to adapt programming to take into account the manual overrides entered into the thermostat, it is first necessary to determine when a manual override has in fact occurred. Most thermostats, including two-way communicating devices discussed herein, do not record such inputs locally, and neither recognize nor transmit the fact that a manual override has occurred. Furthermore, in a system as described herein, frequent changes in setpoints may be initiated by algorithms running on the server, thereby making it impossible to infer a manual override from the mere fact that the setpoint has changed. It is therefore necessary to deduce the occurrence of such events from the data that the subject invention does have access to.

[0039] **Figure 7** illustrates the currently preferred method for detecting the occurrence of a manual override event. In step 1002, the server retrieves the primary data points used to infer the occurrence of a manual override from one or more databases in overall database structure 300. The data should include each of the following: for the most recent point for which it can obtain such data (time0) the actual setpoint as recorded at the thermostat (A0); for the point immediately prior to time0, (time-1), the actual setpoint recorded for the thermostat (A-1); for time0 the setpoint as scheduled by server 106 according to the standard setpoint programming (S0), and for time0 the setpoint as scheduled by server 106 according to the standard setpoint programming (S-1). In step 1004, the server retrieves any additional automated setpoint changes C that have been scheduled for the

thermostat by server 106 at time0. Such changes may include algorithmic changes intended to reduce energy consumption, etc. In step 1006 the server calculates the difference (dA) between A0 and A-1; for example, if the setpoint at T0 is 67 degrees at T-1 and 69 at T0, dA is +2; if the setpoint at T-1 is 70 and the setpoint at T0 is 66, dA is -4. In step 1008, the server performs similar steps in order to calculate dS, the difference between S0 and S-1. This is necessary because, for example, the setpoint may have been changed because the server itself had just executed a change, such as a scheduled change from “away” to “home” mode. In step 1010 the server evaluates and sums all active algorithms and other server-initiated strategies to determine their net effect on setpoint at time0. For example, if one algorithm has increased setpoint at time0 by 2 degrees as a short-term energy savings measure, but another algorithm has decreased the setpoint by one degree to compensate for expected subjective reactions to weather conditions, the net algorithmic effect sC is +1 degree.

[0040] In step 1012, the server calculates the value for M, where M is equal to the difference between actual setpoints dA, less the difference between scheduled setpoints dS, less the aggregate of algorithmic change sC. In step 1014 the server evaluates this difference. If the difference equals zero, the server concludes that no manual override has occurred, and the routine terminates. But if the difference is any value other than zero, then the server concludes that a manual override has occurred. Thus in step 1016 the server logs the occurrence of an override to one or more databases in overall database structure 300.

[0041] The process of interpreting a manual override is shown in **Figure 8**. 1102 is the detection of an override, as described in detail in Figure 7. In step 1104 the server retrieves contextual data required to interpret the manual override. Such data may include current and recent weather conditions, current and recent inside temperatures, etc. This data is helpful because it is likely that manual overrides are at least in part deterministic: that is, that they may often be explained by such contextual data, and that such understanding can permit anticipation of the desire on the part of the occupants to override and to adjust programming accordingly, so as to anticipate and obviate the need for such changes. In step 1106 the server retrieves any override data from the period preceding the specific override being evaluated that has not yet been evaluated by and incorporated into the long-term

programming and rules engines as described below in Figure 9. The amount of data may be for a period of a few hours to as long as several days or more. Recent data will be more heavily weighted than older data in order to assure rapid adaptation to situations in which manual overrides represent stable changes such as changes in work schedules, etc. In step 1108 the server retrieves the stored rules for the subject thermostat 108. Such rules may include weather and time-related inferences such as “if outside temperature is greater than 85 degrees and inside temperature is more than 2 degrees above setpoint and manual override lowers setpoint by 3 or more degrees, then revert to original setpoint in 2 hours,” or “if heating setpoint change is scheduled from “away” to “home” within following 2 hours after detected override, and override increases setpoint by at least 2 degrees, then change to “home” setting,” or the like. In step 1110 the server applies the rules to the override and determines which rule, if any, should be applied as a result of the override. In step 1112 the server determines whether to alter the current setpoint as a result of applying the rules in step 1110. If no setpoint change is indicated, then the server proceeds to step 1118. If a setpoint change is indicated, then in step 1114 the server transmits the setpoint change to the thermostat, and in step 1116 it records that change to one or more databases in overall database structure 300.

[0042] In order to ensure that both the stored rules for interpreting manual overrides and the programming itself continue to most accurately reflect the intentions of the occupants, the server will periodically review both the rules used to interpret overrides and the setpoint scheduling employed. **Figure 9** shows the steps used to incorporate manual overrides into the long-term rules and setpoint schedule. In step 1202 the server retrieves the stored programming for a given thermostat as well as the rules for interpreting overrides for that thermostat. In step 1204 the server retrieves the recent override data as recorded in Figures 7 and 8 to be evaluated for possible revisions to the rules and the programming. In step 1206 the server retrieves the contextual data regarding overrides retrieved in step 1204 (Because the process illustrated in Figure 9 is not presently expected to be executed as a real-time process, and to be run anywhere from once per day to once per month, the range and volume of contextual data to be evaluated is likely to be greater than in the process illustrated in Figure 8). In step 1208 the server interprets the overrides in light of the existing

programming schedule, rules for overrides, contextual data, etc. In step 1210 the server determines whether, as a result of those overrides as interpreted, the rules for interpreting manual overrides should be revised. If the rules are not to be revised, the server moves to step 1214. If the rules are to be revised, then in step 1212 the server revises the rules and the new rules are stored in one or more databases in overall database structure 300. In step 1214 the server determines whether any changes to the baseline programming for the thermostat should be revised. If not the routine terminates. If revisions are warranted, then in step 1216 the server retrieves from database 900 the permissions the server has to make autonomous changes to settings. If the server has been given permission to make the proposed changes, then in step 1218 the server revises the thermostat's programming and writes the changes to one or more databases in overall database structure 300. If the server has not been authorized to make such changes autonomously, then in step 1220 the server transmits the recommendation to change settings to the customer in the manner previously specified by the customer, such as email, changes to the customer's home page as displayed on website 200, etc.

[0043] Figure 10 shows an example of some of the contextual data that may be used by the server in order to interpret manual overrides. Such data may include inside temperature 1302, outside temperature 1304, cloud cover 1306, humidity 1308, barometric pressure 1310, wind speed 1312, and wind direction 1314.

[0044] Each of these data points should be captured at frequent intervals. In the preferred embodiment, as shown in Figure 10, the interval is once every 60 seconds.

[0045] Additional means of implementing the instant invention may be achieved using variations in system architecture. For example, much or even all of the work being accomplished by remote server 106 may also be done by thermostat 108 if that device has sufficient processing capabilities, memory, etc. Alternatively, some or all of these steps may be undertaken by a local processor such as a local personal computer, gateway 112, or by a dedicated appliance having the requisite capabilities.

[0046] While certain embodiments of the inventions have been described, these embodiments have been presented by way of example only, and are not intended to limit the scope of the inventions. Indeed, the novel methods and systems described herein may be

embodied in a variety of other forms; furthermore, various omissions, substitutions and changes in the form of the methods and systems described herein may be made without departing from the spirit of the inventions. The accompanying claims and their equivalents are intended to cover such forms or modifications as would fall within the scope and spirit of the inventions.

WHAT IS CLAIMED IS:

1. A method for detecting manual changes to the setpoint for a thermostatic controller comprising:
 - comparing the actual setpoint at a given time for said thermostatic controller to the expected setpoint for said thermostatic controller in light of the scheduled programming of said thermostatic controller for said given time; and
 - determining whether said actual setpoint and said expected setpoint are the same or different.
2. A method as in Claim 1 where said thermostatic controller operates a system for changing the air temperature in a structure.
3. A method as in Claim 1 where said thermostatic controller operates a heating, ventilation and air conditioning system.
4. A method as in Claim 1 where said thermostatic controller operates a heating, ventilation and air conditioning system in a single family residence.
5. A method as in Claim 1 in which at least one remote processor is in communication with said thermostatic control device.
6. A method as in Claim 5 in which said remote processor is not located in the same structure as said thermostatic controller.
7. A method as in Claim 5 in which said remote processor sets programming for said thermostatic controller.
8. A method as in Claim 1 in which said thermostatic controller is programmable.
9. A method for incorporating manual changes to the setpoint for a thermostatic controller into long-term programming of said thermostatic controller comprising:
 - comparing the actual setpoint at a given time for said thermostatic controller to the expected setpoint for said thermostatic controller in light of the scheduled programming for said given time;
 - determining whether said actual setpoint and said expected setpoint are the same or different;

comparing a manual change to the actual setpoint for said thermostatic controller to previously recorded setpoint data for said thermostatic controller; and
applying at least one rule for the interpretation of said manual change in light of said previously recorded setpoint data.

10. A method as in Claim 9 where said thermostatic controller operates a system for changing the air temperature in a structure.

11. A method as in Claim 9 where said thermostatic controller operates a heating, ventilation and air conditioning system.

12. A method as in Claim 9 where said thermostatic controller operates a heating, ventilation and air conditioning system in a single family residence.

13. A method as in Claim 9 in which at least one remote processor is in communication with said thermostatic control device.

14. A method as in Claim 13 in which said remote processor is not located in the same structure as said thermostatic controller.

15. A method as in Claim 13 in which said remote processor sets programming for said thermostatic controller.

16. A system as in Claim 9 in which said thermostatic controller is programmable.

17. An apparatus for detecting manual changes to the setpoint for a thermostatic controller comprising:

at least a programmable communicating thermostat;

at least a remote processor;

at least a network connecting said remote processor and said communicating;

at least a database that stores scheduled setpoint programming for said programmable communicating thermostat;

at least a database that stores actual setpoint programming for said programmable communicating thermostat; and

means to compare said scheduled setpoint programming with said actual setpoint programming.

18. An apparatus as in Claim 17 where said programmable communicating thermostat operates a system for changing the air temperature in a structure.

19. An apparatus as in Claim 17 where said programmable communicating thermostat operates a heating, ventilation and air conditioning system.

20. An apparatus as in Claim 17 where said programmable communicating thermostat operates a heating, ventilation and air conditioning system in a single family residence.

21. An apparatus as in Claim 20 in which at least one remote processor is in communication with said programmable communicating thermostat.

22. An apparatus as in Claim 20 in which said remote processor is not located in the same structure as said programmable communicating thermostat.

23. An apparatus as in Claim 20 in which said remote processor sets programming for said programmable communicating thermostat.

SYSTEM, METHOD AND APPARATUS FOR IDENTIFYING MANUAL INPUTS TO
AND ADAPTIVE PROGRAMMING OF A THERMOSTAT

ABSTRACT OF THE DISCLOSURE

Systems and methods are disclosed for incorporating manual changes to the setpoint for a thermostatic controller into long-term programming of the thermostatic controller. For example, one or more of the exemplary systems compares the actual setpoint at a given time for the thermostatic controller to an expected setpoint for the thermostatic controller in light of the scheduled programming. A determination is then made as to whether the actual setpoint and the expected setpoint are the same or different. Furthermore, a manual change to the actual setpoint for the thermostatic controller is compared to previously recorded setpoint data for the thermostatic controller. At least one rule is then applied for the interpretation of the manual change in light of the previously recorded setpoint data.

8960742
042810

INFORMATION DISCLOSURE STATEMENT

Applicant	: Steinberg, et al.
App. No	: Unknown
Filed	: Herewith
For	: SYSTEM, METHOD AND APPARATUS FOR IDENTIFYING MANUAL INPUTS TO AND ADAPTIVE PROGRAMMING OF A THERMOSTAT
Examiner	: Unknown
Art Unit	: Unknown
Conf No.	: Unknown

Commissioner for Patents
P.O. Box 1450
Alexandria, VA 22313-1450

Dear Sir:

Enclosed for filing in the above-identified application is a PTO/SB/08 Equivalent listing seventy eight (78) references, of which fourteen (14) are enclosed/submitted.

This Information Disclosure Statement is being filed within three months of the filing date and no fee is required.

The Commissioner is hereby authorized to charge any additional fees which may be required, or credit any overpayment, to Account No. 11-1410.

Respectfully submitted,
KNOBBE, MARTENS, OLSON & BEAR, LLP

Dated: 5-11-2010

By: John R. King
John R. King
Registration No. 34,362
Attorney of Record
Customer No. 20,995
(949) 760-0404

9021475:ad
050710

INFORMATION DISCLOSURE STATEMENT

Applicant	: Steinberg, et al.
App. No	: Unknown
Filed	: Herewith
For	: SYSTEM, METHOD AND APPARATUS FOR IDENTIFYING MANUAL INPUTS TO AND ADAPTIVE PROGRAMMING OF A THERMOSTAT
Examiner	: Unknown
Art Unit	: Unknown
Conf No.	: Unknown

Commissioner for Patents
P.O. Box 1450
Alexandria, VA 22313-1450

Dear Sir:

Enclosed for filing in the above-identified application is a PTO/SB/08 Equivalent listing seventy eight (78) references, of which fourteen (14) are enclosed/submitted.

This Information Disclosure Statement is being filed within three months of the filing date and no fee is required.

The Commissioner is hereby authorized to charge any additional fees which may be required, or credit any overpayment, to Account No. 11-1410.

Respectfully submitted,
KNOBBE, MARTENS, OLSON & BEAR, LLP

Dated: 5-11-2010

By: John R. King
John R. King
Registration No. 34,362
Attorney of Record
Customer No. 20,995
(949) 760-0404

9021475:ad
050710

Filing Date: 05/11/10

Approved for use through 7/31/2006. OMB 0651-0032
 U.S. Patent and Trademark Office; U.S. DEPARTMENT OF COMMERCE

Under the Paperwork Reduction Act of 1995, no persons are required to respond to a collection of information unless it displays a valid OMB control number.

PATENT APPLICATION FEE DETERMINATION RECORD Substitute for Form PTO-875					Application or Docket Number 12/778,052					
APPLICATION AS FILED – PART I (Column 1) (Column 2)					SMALL ENTITY		OR		OTHER THAN SMALL ENTITY	
FOR	NUMBER FILED	NUMBER EXTRA			RATE (\$)	FEE (\$)		RATE (\$)	FEE (\$)	
BASIC FEE (37 CFR 1.16(a), (b), or (c))	N/A	N/A			N/A	82		N/A		
SEARCH FEE (37 CFR 1.16(k), (l), or (m))	N/A	N/A			N/A	270		N/A		
EXAMINATION FEE (37 CFR 1.16(o), (p), or (q))	N/A	N/A			N/A	110		N/A		
TOTAL CLAIMS (37 CFR 1.16(i))	23	minus 20 =	3		x\$26	78		x\$52		
INDEPENDENT CLAIMS (37 CFR 1.16(h))	3	minus 3 =	*		x\$110			x\$220		
APPLICATION SIZE FEE (37 CFR 1.16(s))	If the specification and drawings exceed 100 sheets of paper, the application size fee due is \$270 (\$135 for small entity) for each additional 50 sheets or fraction thereof. See 35 U.S.C. 41(a)(1)(G) and 37 CFR									
					195			390		
					TOTAL	540		TOTAL		
APPLICATION AS AMENDED – PART II (Column 1) (Column 2) (Column 3)					SMALL ENTITY		OR		OTHER THAN SMALL ENTITY	
AMENDMENT A		CLAIMS REMAINING AFTER AMENDMENT		HIGHEST NUMBER PREVIOUSLY PAID FOR	PRESENT EXTRA					
	Total (37 CFR 1.16(i))	*	Minus	**	=	X =		X =		
	Independent (37 CFR 1.16(h))	*	Minus	***	=	X =		X =		
	Application Size Fee (37 CFR 1.16(s))									
	FIRST PRESENTATION OF MULTIPLE DEPENDENT CLAIM (37 CFR 1.16(j))					N/A		N/A		
					TOTAL			TOTAL		
					ADD'T FEE			ADD'T FEE		
AMENDMENT B		CLAIMS REMAINING AFTER AMENDMENT		HIGHEST NUMBER PREVIOUSLY PAID FOR	PRESENT EXTRA					
	Total (37 CFR 1.16(i))	*	Minus	**	=	X =		X =		
	Independent (37 CFR 1.16(h))	*	Minus	***	=	X =		X =		
	Application Size Fee (37 CFR 1.16(s))									
	FIRST PRESENTATION OF MULTIPLE DEPENDENT CLAIM (37 CFR 1.16(j))					N/A		N/A		
					TOTAL			TOTAL		
					ADD'T FEE			ADD'T FEE		

* If the entry in column 1 is less than the entry in column 2, write "0" in column 3.
 ** If the "Highest Number Previously Paid For" IN THIS SPACE is less than 20, enter "20".
 *** If the "Highest Number Previously Paid For" IN THIS SPACE is less than 3, enter "3".
 The "Highest Number Previously Paid For" (Total or Independent) is the highest number found in the appropriate box in column 1.

This collection of information is required by 37 CFR 1.16. The information is required to obtain or retain a benefit by the public which is to file (and by the USPTO to process) an application. Confidentiality is governed by 35 U.S.C. 122 and 37 CFR 1.14. This collection is estimated to take 12 minutes to complete, including gathering, preparing, and submitting the completed application form to the USPTO. Time will vary depending upon the individual case. Any comments on the amount of time you require to complete this form and/or suggestions for reducing this burden, should be sent to the Chief Information Officer, U.S. Patent and Trademark Office, U.S. Department of Commerce, P.O. Box 1450, Alexandria, VA 22313-1450. DO NOT SEND FEES OR COMPLETED FORMS TO THIS ADDRESS. **SEND TO: Commissioner for Patents, P.O. Box 1450, Alexandria, VA 22313-1450.**

If you need assistance in completing the form, call 1-800-PTO-9199 and select option 2.