



US 20060092348A1

(19) **United States**

(12) **Patent Application Publication** (10) **Pub. No.: US 2006/0092348 A1**

**Park** (43) **Pub. Date: May 4, 2006**

(54) **BACKLIGHT UNIT AND LIQUID CRYSTAL DISPLAY WITH THE SAME**

**Publication Classification**

(75) Inventor: **Hee Jeong Park**, Bucheon-si (KR)

(51) **Int. Cl.**  
**G02F 1/1335** (2006.01)

(52) **U.S. Cl.** ..... **349/64**

Correspondence Address:

**BIRCH STEWART KOLASCH & BIRCH**  
**PO BOX 747**  
**FALLS CHURCH, VA 22040-0747 (US)**

(57) **ABSTRACT**

(73) Assignee: **LG, Philips LCD Co., Ltd.**

(21) Appl. No.: **11/258,954**

(22) Filed: **Oct. 27, 2005**

(30) **Foreign Application Priority Data**

Oct. 30, 2004 (KR) ..... 10-2004-0087582

A backlight unit and a liquid crystal display device including such a backlight unit are provided. According to an embodiment, there is provided a backlight unit comprising a plurality of light emitting diodes (LEDs) for generating light, a printed circuit board (PCB) for controlling the LEDs, a transparent scattering plate provided with a scattering optical pattern for scattering the light from the LEDs, and a diffusing plate for diffusing the light scattered by the scattering plate.

100

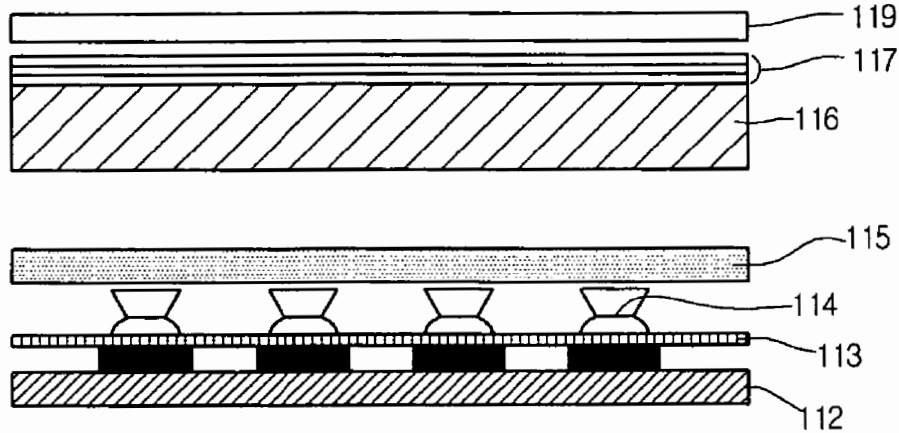

Fig. 1  
Related Art

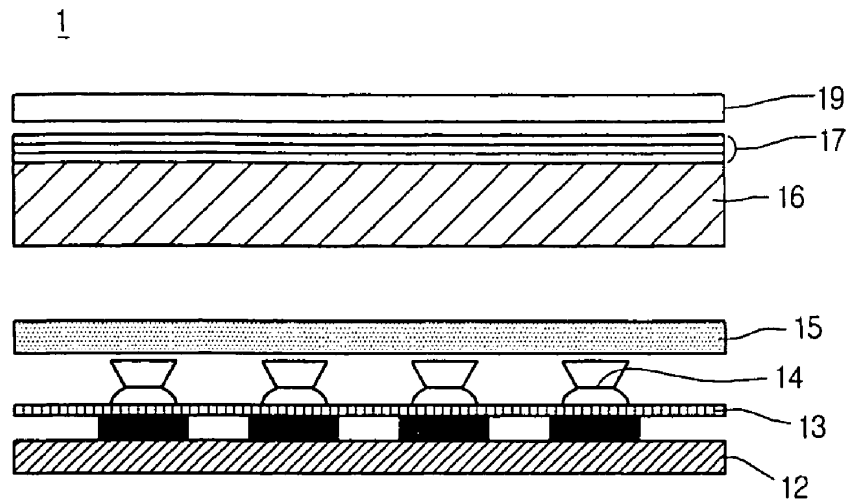

Fig. 2  
Related Art

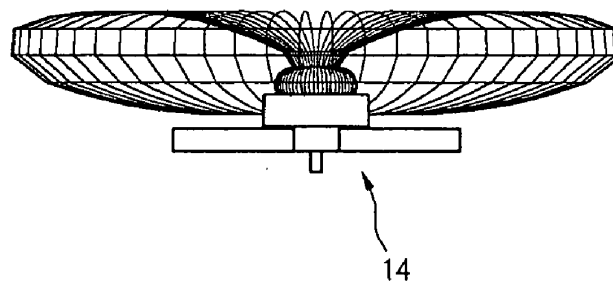

Fig.3

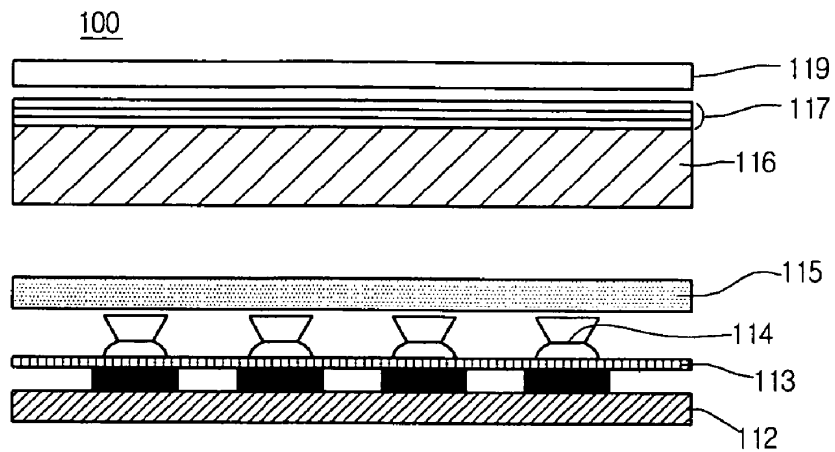
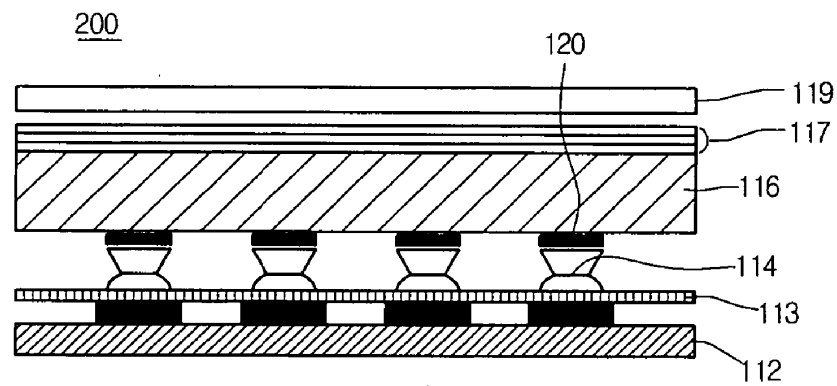

Fig.4



**BACKLIGHT UNIT AND LIQUID CRYSTAL DISPLAY WITH THE SAME**

[0001] This application claims priority under 35 U.S.C. §119 on Patent Application No. 10-2004-0087582 filed on Oct. 30, 2004 in the Republic of Korea, the entire contents of which are hereby incorporated by reference.

**BACKGROUND OF THE INVENTION**

[0002] 1. Field of the Invention

[0003] The present invention relates to a backlight unit that can reduce light losses that may be caused by leakage of the light to an external side. The present invention further relates to a liquid crystal display (LCD) with such a backlight unit.

[0004] 2. Description of the Related Art

[0005] In recent years, an LCD has increasingly gained attention as a flat display device that varies optical anisotropy by applying an electric field to liquid crystal having a fluidity property as well as a crystal optical property. Since the LCD is relatively slim, with low electric consumption and capability of being made in a large-sized display panel with a high definition, it has been widely used.

[0006] Generally, such an LCD has a liquid crystal panel that displays a desired image on a screen by adjusting an amount of light fed from a backlight unit. The liquid crystal panel includes a plurality of liquid crystal cells arranged in a matrix pattern and a plurality of control switches for converting video signals that are to be fed to the liquid crystal cells.

[0007] In order to reduce a thickness of the LCD, the backlight unit used for the LCD has been made slimmer and light-weight. To accomplish this, a light emitting diode (LED) instead of CCFL has been used for the backlight unit since the light emitting diode is favorable in an electric power consumption, weight and brightness.

[0008] **FIG. 1** is a sectional view of a related art liquid crystal display with an LED backlight unit and **FIG. 2** is a view illustrating a light emission from a related art side emitter type LED.

[0009] As shown in **FIG. 1**, a related art liquid crystal display 1 includes a liquid crystal panel 19 having upper and lower substrates between which liquid crystal disposed and a backlight unit feeding light to the liquid crystal panel 19.

[0010] The backlight unit includes a plurality of LEDs 14, a metal core printed circuit board (MCPCB) 12 disposed under the plurality of the LEDs 14, a scattering plate 15 formed of polymethylmethacrylate (PMMA) to scatter the light generated from the LEDs 14, and a diffusing plate 16 for diffusing the light that has passed through the scattering plate 15. A variety of optical sheets 17 are disposed on the diffusing plate 16. A reflecting plate 13 is disposed between the LEDs 14 and the MCPCB 12 for reflecting light, which cannot transmit the diffusing plate 16 but is directed toward the MCPCB 12, toward the scattering plate 15.

[0011] The LEDs 14 are point light sources that emit red, green and blue lights. The MCPCB 12 is provided with a circuit for controlling the LEDs 14, and has relatively high heat dissipation property as compared with a conventional

PCB. The MCPCB 12 functions to support the LEDs 14 as well as to control the light emission of the LEDs 14 using the circuit formed thereon.

[0012] A scattering optical pattern (not shown) is formed on a rear surface of the scattering plate 15. As shown in **FIG. 2**, the side emitting type LED 14 is designed to emit the light in a side direction rather than a vertical direction. However, in order to prevent the bright dot with respect to the light emitted in the vertical direction, the scattering plate 15 is provided to scatter the light as much as possible, thereby improving the brightness uniformity.

[0013] The diffusing plate 16 is spaced apart from the LEDs 14 at a predetermined distance so as to allow the light from the scattering plate 15 to have a more uniform distribution.

[0014] The reflecting plate 13 reflects the light that is reflected from the scattering plate 15 and/or the diffusing plate 16 and directed thereto or the light directly from the LEDs 14, thereby reducing the light loss.

[0015] In the above-described LCD 1, the light generated from the LEDs 14 is consecutively advanced to the scattering plate 15 and the diffusing plate 16, thereby providing the light having a uniform brightness to the liquid crystal panel 19.

[0016] As described above, the scattering plate 15 is formed of the PMMA to uniformly scatter the light generated from the LEDs 14. The PMMA is not transparent.

[0017] However, since the scattering plate formed of the PMMA has properties of a high coefficient of linear expansion and a low heat deformation temperature, it may be easily deformed under a high temperature/humidity environment.

[0018] The deformation of the scattering plate deteriorates the reliability of the backlight unit and thus the LCD.

[0019] Furthermore, the scattering plate formed of the PMMA cannot completely scatter the light generated in a vertical direction of the LEDs, thereby causing the poor bright spot.

**SUMMARY OF THE INVENTION**

[0020] Accordingly, the present invention is directed to a backlight unit/device and an LCD with the backlight unit, which substantially obviate one or more problems due to limitations and disadvantages of the related art.

[0021] An object of the present invention is to provide a backlight unit that has a scattering plate formed of tempered glass, thereby improving light transmission and reliability of an LCD even under high temperature/humidity environments.

[0022] Another object of the present invention is to provide a backlight unit in which a scattering plate is omitted, thereby reducing the manufacturing costs and thickness of an LCD.

[0023] Another object of the present invention is to provide an LCD having one of such backlight units.

[0024] Additional advantages, objects, and features of the invention will be set forth in part in the description which follows and in part will become apparent to those having

ordinary skill in the art upon examination of the following or may be learned from practice of the invention. The objectives and other advantages of the invention may be realized and attained by the structure particularly pointed out in the written description and claims hereof as well as the appended drawings.

[0025] To achieve these objects and other advantages and in accordance with the purpose of the invention, as embodied and broadly described herein, there is provided a backlight unit comprising a plurality of light emitting diodes (LEDs) for generating light, a printed circuit board (PCB) for controlling the LEDs, a transparent scattering plate provided with a scattering optical pattern for scattering the light from the LEDs, and a diffusing plate for diffusing the light scattered by the scattering plate.

[0026] In another aspect of the present invention, there is provided a liquid crystal display device comprising a liquid crystal panel having upper and lower substrates between which a liquid crystal layer is formed, a plurality of light emitting diodes (LEDs) for generating light, a printed circuit board (PCB) for controlling the LEDs, a transparent scattering plate provided with a scattering optical pattern for scattering the light from the LEDs, and a diffusing plate for diffusing the light scattered by the scattering plate and directing the diffused light towards the liquid crystal panel.

[0027] In still yet another aspect of the present invention, there is provided a backlight unit comprising a plurality of light emitting diodes (LEDs) for generating light, a printed circuit board (PCB) for controlling the LEDs, and a diffusing plate having a diverter for scattering the light generated from the LEDs.

[0028] In still another aspect of the present invention, there is provided a liquid crystal display device comprising a liquid crystal panel having upper and lower substrates between which a liquid crystal layer is formed, a plurality of light emitting diodes (LEDs) for generating light, a printed circuit board (PCB) for controlling the LEDs, and a diffusing plate having a diverter for scattering the light generated from the LEDs, wherein the diffusing plate diffuses the scattered light and directs the diffused light towards the liquid crystal panel.

[0029] In still yet another aspect of the present invention, there is provided a backlight device for a display panel, the device comprising a plurality of light emitting diodes (LEDs) configured to generate light, a scattering plate made of glass and disposed above the LEDs, the scattering plate having a scattering pattern thereon to scatter the light from the LEDs, and a diffusing plate disposed above the scattering plate with a gap between the diffusing plate and the scattering plate and configured to diffuse the scattered light and to direct the diffused light towards the display panel.

[0030] In still yet another aspect of the present invention, there is provided a backlight device for a display panel, the device comprising a plurality of light emitting diodes (LEDs) configured to generate light, and a diffusing plate disposed above the LEDs, and including a structure for scattering the light from the LEDs, wherein the scattering structure is attached on a surface of a portion of the diffusing plate, and the diffusing plate diffuses the scattered light and directs the diffused light towards the display panel.

[0031] It is to be understood that both the foregoing general description and the following detailed description of

the present invention are exemplary and explanatory and are intended to provide further explanation of the invention as claimed.

#### BRIEF DESCRIPTION OF THE DRAWINGS

[0032] The accompanying drawings, which are included to provide a further understanding of the invention and are incorporated in and constitute a part of this application, illustrate embodiment(s) of the invention and together with the description serve to explain the principle of the invention. In the drawings:

[0033] **FIG. 1** is a sectional view of a related art LCD with an LED backlight unit;

[0034] **FIG. 2** is a view illustrating a light emission from a related art side emitter type LED;

[0035] **FIG. 3** is a sectional view of an LED with an LED backlight unit according to a first embodiment of the present invention; and

[0036] **FIG. 4** is a sectional view of an LED with an LED backlight unit according to a second embodiment of the present invention.

#### DETAILED DESCRIPTION OF THE PREFERRED EMBODIMENTS

[0037] Reference will now be made in detail to the preferred embodiments of the present invention, examples of which are illustrated in the accompanying drawings. Wherever possible, the same reference numbers will be used throughout the drawings to refer to the same or like parts.

##### First Embodiment

[0038] **FIG. 3** shows an LCD with a backlight unit according to a first embodiment of the present invention.

[0039] Referring to **FIG. 3**, an LCD **100** of this embodiment includes a liquid crystal panel **119** having an upper substrate on which red, green and blue color filter layers and a black matrix are formed and a lower substrate on which pixel electrodes and thin film transistors (TFTs) are formed, and a backlight unit for supplying light to the liquid crystal panel **119**. A liquid crystal layer is formed between the upper and lower substrates of the liquid crystal panel **119**.

[0040] The backlight unit includes a transparent scattering plate **115** formed of tempered glass to scatter the light generated from a plurality of LEDs **114**, and a diffusing plate **116** for diffusing the light that has passed through the scattering plate **115**. A variety of optical sheets **117** are disposed on the diffusing plate **116**. A reflecting plate **113** is disposed between the LEDs **114** and a MCPCB **112** for reflecting light, which is directed toward the MCPCB **112**, toward the scattering plate **115**.

[0041] The LEDs **114** are point light sources that emit red, green and blue lights, and can be the side emitting type or other types.

[0042] The MCPCB **112** includes one or more circuits for controlling the LEDs **114**. An electrode unit may be formed on the circuit(s) of the MCPCB **112** to transmit control signals to the LEDs **114** and support the LEDs **114**. Therefore, the MCPCB **112** controls the light emission of the LEDs **114** using the circuit(s) and the electrode unit(s).

# Explore Litigation Insights

Docket Alarm provides insights to develop a more informed litigation strategy and the peace of mind of knowing you're on top of things.

## Real-Time Litigation Alerts



Keep your litigation team up-to-date with **real-time alerts** and advanced team management tools built for the enterprise, all while greatly reducing PACER spend.

Our comprehensive service means we can handle Federal, State, and Administrative courts across the country.

## Advanced Docket Research



With over 230 million records, Docket Alarm's cloud-native docket research platform finds what other services can't. Coverage includes Federal, State, plus PTAB, TTAB, ITC and NLRB decisions, all in one place.

Identify arguments that have been successful in the past with full text, pinpoint searching. Link to case law cited within any court document via Fastcase.

## Analytics At Your Fingertips



Learn what happened the last time a particular judge, opposing counsel or company faced cases similar to yours.

Advanced out-of-the-box PTAB and TTAB analytics are always at your fingertips.

## API

Docket Alarm offers a powerful API (application programming interface) to developers that want to integrate case filings into their apps.

## LAW FIRMS

Build custom dashboards for your attorneys and clients with live data direct from the court.

Automate many repetitive legal tasks like conflict checks, document management, and marketing.

## FINANCIAL INSTITUTIONS

Litigation and bankruptcy checks for companies and debtors.

## E-DISCOVERY AND LEGAL VENDORS

Sync your system to PACER to automate legal marketing.