

UNITED STATES PATENT AND TRADEMARK OFFICE
CERTIFICATE OF CORRECTION

PATENT NO. : 6,959,293 B2
APPLICATION NO. : 09/792436
DATED : October 25, 2005
INVENTOR(S) : Patrick Pirim

Page 1 of 1

It is certified that error appears in the above-identified patent and that said Letters Patent is hereby corrected as shown below:

Title Page, please add the following section

--(30) Foreign Application Priority Data

Feb. 24, 2000 (FR) 00 02355--.

In the drawings, Sheet 31, Fig. 40, replace each occurrence of "Apprentissage" with --Learning-- and replace "Classification automatique" with --Automatic Classification--.

Column 1, line 13, replace "and is particularly useful" with --and are particularly useful--.

Column 26, line 44, please add a ";" after "a control unit" to read --a control unit;--.

Column 27, lines 5-6, replace "two or more histogram calculation unit" with --two or more histogram calculation units--; line 16, replace "said unit" with --said at least one calculation unit--; line 66, replace "End" with --END--.

Signed and Sealed this

Twenty-first Day of September, 2010

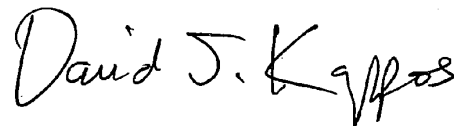

David J. Kappos
Director of the United States Patent and Trademark Office



UNITED STATES PATENT AND TRADEMARK OFFICE

UNITED STATES DEPARTMENT OF COMMERCE
United States Patent and Trademark Office
Address: COMMISSIONER FOR PATENTS
P.O. Box 1450
Alexandria, Virginia 22313-1450
www.uspto.gov

APPLICATION NUMBER	FILING OR 371(C) DATE	FIRST NAMED APPLICANT	ATTY. DOCKET NO./TITLE
09/792,436	02/23/2001	Patrick Pirim	8042-5

CONFIRMATION NO. 9956

POA ACCEPTANCE LETTER

86000
Gregory A. Nelson
Novak Druce & Quigg LLP
525 Okeechobee Blvd
Suite 1500
West Palm Beach, FL 33401



Date Mailed: 08/30/2010

NOTICE OF ACCEPTANCE OF POWER OF ATTORNEY

This is in response to the Power of Attorney filed 08/20/2010.

The Power of Attorney in this application is accepted. Correspondence in this application will be mailed to the above address as provided by 37 CFR 1.33.

/ghien-aime/

Office of Data Management, Application Assistance Unit (571) 272-4000, or (571) 272-4200, or 1-888-786-0101



UNITED STATES PATENT AND TRADEMARK OFFICE

UNITED STATES DEPARTMENT OF COMMERCE
United States Patent and Trademark Office
Address: COMMISSIONER FOR PATENTS
P.O. Box 1450
Alexandria, Virginia 22313-1450
www.uspto.gov

APPLICATION NUMBER	FILING OR 371(C) DATE	FIRST NAMED APPLICANT	ATTY. DOCKET NO./TITLE
09/792,436	02/23/2001	Patrick Pirim	20046H-000100

CONFIRMATION NO. 9956

POWER OF ATTORNEY NOTICE

20350
TOWNSEND AND TOWNSEND AND CREW, LLP
TWO EMBARCADERO CENTER
EIGHTH FLOOR
SAN FRANCISCO, CA 94111-3834



Date Mailed: 08/30/2010

NOTICE REGARDING CHANGE OF POWER OF ATTORNEY

This is in response to the Power of Attorney filed 08/20/2010.

- The Power of Attorney to you in this application has been revoked by the assignee who has intervenered as provided by 37 CFR 3.71. Future correspondence will be mailed to the new address of record(37 CFR 1.33).

/gbien-aime/

Office of Data Management, Application Assistance Unit (571) 272-4000, or (571) 272-4200, or 1-888-786-0101

Under the Paperwork Reduction Act of 1995, no persons are required to respond to a collection of information unless it displays a valid OMB control number.

**POWER OF ATTORNEY
OR
REVOCATION OF POWER OF ATTORNEY
WITH A NEW POWER OF ATTORNEY
AND
CHANGE OF CORRESPONDENCE ADDRESS**

Application Number	09/792,436
Filing Date	October 25, 2005
First Named Inventor	PIRIM, PATRICK
Title	METHOD AND DEVICE FOR AUTOMATIC VISUAL PERCEPTION
Art Unit	2121
Examiner Name	DAVIS, GEORGE B
Attorney Docket Number	8042-5

I hereby revoke all previous powers of attorney given in the above-identified application.

 A Power of Attorney is submitted herewith.

OR

 I hereby appoint Practitioner(s) associated with the following Customer Number as my/our attorney(s) or agent(s) to prosecute the application identified above, and to transact all business in the United States Patent and Trademark Office connected therewith:

86000

OR

 I hereby appoint Practitioner(s) named below as my/our attorney(s) or agent(s) to prosecute the application identified above, and to transact all business in the United States Patent and Trademark Office connected therewith:

Practitioner(s) Name	Registration Number

Please recognize or change the correspondence address for the above-identified application to:

 The address associated with the above-mentioned Customer Number.

OR

 The address associated with Customer Number:

OR

 Firm or Individual Name

Address

City

State

Zip

Country

Telephone

Email

I am the:

 Applicant/Inventor.

OR

 Assignee of record of the entire interest. See 37 CFR 3.71.

Statement under 37 CFR 3.73(b) (Form PTO/SB/96) submitted herewith or filed on _____.

SIGNATURE of Applicant or Assignee of Record

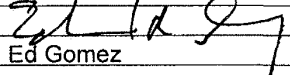
Signature		Date	8.17.10
Name	Ed Gomez	Telephone	845-368-4000 x110
Title and Company	Chief IP Counsel, General Patent Corp. / General Patent Corp. is Manager, Image Processing Technologies LLC		

NOTE: Signatures of all the inventors or assignees of record of the entire interest or their representative(s) are required. Submit multiple forms if more than one signature is required, see below*. *Total of 1 forms are submitted.

This collection of information is required by 37 CFR 1.31, 1.32 and 1.33. The information is required to obtain or retain a benefit by the public which is to file (and by the USPTO to process) an application. Confidentiality is governed by 35 U.S.C. 122 and 37 CFR 1.11 and 1.14. This collection is estimated to take 3 minutes to complete, including gathering, preparing, and submitting the completed application form to the USPTO. Time will vary depending upon the individual case. Any comments on the amount of time you require to complete this form and/or suggestions for reducing this burden, should be sent to the Chief Information Officer, U.S. Patent and Trademark Office, U.S. Department of Commerce, P.O. Box 1450, Alexandria, VA 22313-1450. DO NOT SEND FEES OR COMPLETED FORMS TO THIS ADDRESS. SEND TO: Commissioner for Patents, P.O. Box 1450, Alexandria, VA 22313-1450.

If you need assistance in completing the form, call 1-800-PTO-9199 and select option 2.

IN THE UNITED STATES PATENT AND TRADEMARK OFFICE

In re: Application of	PIRIM	Confirmation No.	9956
Patent No.	6,959,293 B2	Group:	2121
Issue Date:	October 25, 2005	Examiner:	DAVIS, GEORGE B
Application No.	09/792,436	Docket No.	8042-5
Filing Date:	February 23, 2001		

For: METHOD AND DEVICE FOR AUTOMATIC VISUAL PERCEPTION

REQUEST FOR CERTIFICATE OF CORRECTION

ATTN: Certificate of Corrections Branch
Commissioner for Patents
P.O. Box 1450
Alexandria, VA 22313-1450

Sir or Madam:

On behalf of Image Processing Technologies LLC, the assignee of record, the undersigned hereby requests that a Certificate of Correction pursuant to 37 C.F.R. §§ 1.322, 1.323 be issued on the above-entitled patent. The correction is indicated in appropriate form on attached Form PTO/SB/44.

The requested corrections either (i) relate to the omission of the priority claim to FR 00 02355 on the first page of the above-referenced patent by the United States Patent and Trademark Office (USPTO); (ii) relate to typographical errors which were made by the applicant; or (iii) relate to clerical or typographical mistakes made by the applicant during translation of the original patent application from French to English. All of the requested

corrections do not constitute new matter, do not affect the scope of any claim and do not require reexamination.

With respect to the requested correction of the priority claim, although reference to a priority claim was not made in the first paragraph of the specification of U.S. Patent No. 6,959,293, applicant did refer to the priority claim on the application transmittal letter filed with the application (09/792,436) on February 23, 2001. The applicant also identified FR 00 02355 as a prior foreign application in the Declaration and Power of Attorney filed on April 9, 2002, though the box below Priority Claimed Under 35 USC 119 is blank. In addition, the USPTO included the priority claim on the title page of the published patent application (20020169732), as well as in the Office Action mailed March 26, 2004 and the Notice of Allowability mailed on October 6, 2004. In the Office Action and Notice of Allowability, the examiner acknowledged a claim of foreign priority under 35 U.S.C. § 119(a)-(d) or (f) but indicated that the certified copy had not been received. In a response to the Notice of Allowability dated October 22, 2004, applicant stated: "The undersigned, however, respectfully asserts that a certified copy of the priority document was filed on August 26, 2004, and was indeed received by the Patent Office as evidenced by its availability through the PAIR website. Correction of this acknowledgement is respectfully requested." In the Supplemental Notice of Allowability mailed on December 30, 2004, the examiner acknowledged the claim of foreign priority and that certified copies of all priority documents had been received. Assignee notes that the priority claim to FR 00 02355 is referred to under the "foreign priority" tab on PAIR for the above-referenced patent. Subsequent to the December 30, 2004 Supplemental Notice of Allowability, the USPTO omitted the priority claim in a second Supplemental Notice of Allowability mailed on April 27, 2005. A copy of the cited documents is filed herewith. Assignee submits that the priority claim to FR 00 02355 is

clearly disclosed by the records of the USPTO; therefore a Certificate of Correction is a valid means for amending the issued patent to include the priority claim mistakenly omitted by the USPTO. *See* 35 U.S.C. § 254; 37 C.F.R. § 1.322.

For the foregoing reasons, it is respectfully requested that the Commissioner issue a Certificate of Correction making the aforementioned requested corrections. Please contact the undersigned if clarification is required.

Credit card payment in the amount of \$100.00 accompanies this Request. Although no additional fees are believed to be due, the Commissioner for Patents is hereby authorized to charge any underpayment in fees to Deposit Account No. 14-1437. In the event that the Office requires additional information regarding this Request, please contact the undersigned representative Karen Kline (direct line: 561-847-7814).

Respectfully submitted,

NOVAK DRUCE + QUIGG LLP

Date: August 19, 2010

/Gregory A. Nelson/
Gregory A. Nelson, Reg. No. 30,577
Karen C. Kline, Reg. No. 59,907
525 Okeechobee Blvd., 15th Floor
West Palm Beach, FL 33401
Tel: 561-847-7800
Fax: 561-847-7801

CITED DOCUMENTS

02-28-01

Customer No. 20350
TOWNSEND and TOWNSEND and CREW LLP
Two Embarcadero Center, 8th Floor
San Francisco, California 94111-3834
(925) 472-5000

Attorney Docket No. 20046H-000100US

Client Ref No.

"Express Mail" Label No. EL 769 991 202US

Date of Deposit: 2/23/01

U.S. PTO
09/792496
102/23/01
A

ASSISTANT COMMISSIONER FOR PATENTS
BOX PATENT APPLICATION
Washington, D.C. 20231

I hereby certify that this is being deposited with the United States
Postal Service "Express Mail Post Office to Addressee" service
under 37 CFR 1.10 on the date indicated above, addressed to:

Assistant Commissioner for Patents
Washington, D.C. 20231

By: Anthony Pilleran 2/23/01

02/23/01
U.S. PTO

Transmitted herewith for filing under 37 CFR 1.53(b) is the

- patent application of
- continuation patent application of
- divisional patent application of
- continuation-in-part patent application of

Inventor(s)/Applicant Identifier: Patrick Pirim, Paris, France

For: METHOD AND DEVICE FOR AUTOMATIC VISUAL PERCEPTION

This application claims priority from each of the following Application Nos./filing dates:

France 00 02355 filed 02/24/00

the disclosure(s) of which is (are) incorporated by reference.

Enclosed are:

- 37 page(s) of specification
- 8 page(s) of claims
- 1 page of Abstract
- 28 sheet(s) of formal informal drawing(s).
- An assignment of the invention to _____
- An unsigned Declaration & Power of Attorney
- Appendix A (8 sheets including cover sheet).
- Information Disclosure Statement with Form PTO-1449 with 3 references.
- Preliminary Amendment.
- Return postcard.

In view of the Unsigned Declaration as filed with this application and pursuant to 37 CFR §1.53(f),
Applicant requests deferral of the filing fee until submission of the Missing Parts of Application.

DO NOT CHARGE THE FILING FEE AT THIS TIME.

Gerald T. Gray
Gerald T. Gray
Reg No.: 41,797
Attorney for Applicants

Telephone:
(925) 472-5000

Facsimile:
(415) 576-0300



525 Attorney Docket No.: 20046H-000100US
328L vs

DECLARATION AND POWER OF ATTORNEY

As a below named inventor, I declare that:

My residence, post office address and citizenship are as stated below next to my name; I believe I am the original, first and sole inventor (if only one name is listed below) or an original, first and joint inventor (if plural inventors are named below) of the subject matter which is claimed and for which a patent is sought on the invention entitled: **METHOD AND DEVICE FOR AUTOMATIC VISUAL PERCEPTION** the specification of which _____ is attached hereto or _____ was filed on 02/24/00 as Application No. 09739136 and was amended on _____ (if applicable).

I have reviewed and understand the contents of the above identified specification, including the claims, as amended by any amendment referred to above. I acknowledge the duty to disclose information which is material to patentability as defined in Title 37, Code of Federal Regulations, Section 1.56. I claim foreign priority benefits under Title 35, United States Code, Section 119 of any foreign application(s) for patent or inventor's certificate listed below and have also identified below any foreign application for patent or inventor's certificate having a filing date before that of the application on which priority is claimed.

Prior Foreign Application(s)

Country	Application No.	Date of Filing	Priority Claimed Under 35 USC 119
France	00 02355	02/24/00	

I hereby claim the benefit under Title 35, United States Code § 119(e) of any United States provisional application(s) listed below:

Application No.	Filing Date

I claim the benefit under Title 35, United States Code, Section 120 of any United States application(s) listed below and, insofar as the subject matter of each of the claims of this application is not disclosed in the prior United States application in the manner provided by the first paragraph of Title 35, United States Code, Section 112, I acknowledge the duty to disclose material information as defined in Title 37, Code of Federal Regulations, Section 1.56 which occurred between the filing date of the prior application and the national or PCT international filing date of this application:

Application No.	Date of Filing	Status

POWER OF ATTORNEY: As a named inventor, I hereby appoint the following attorney(s) and/or agent(s) to prosecute this application and transact all business in the Patent and Trademark Office connected therewith.

Gerald T. Gray, Reg. No. 41,797
Babak S. Sani, Reg. No. 37,495

Send Correspondence to: Gerald T. Gray TOWNSEND and TOWNSEND and CREW LLP Two Embarcadero Center, 8 th Floor San Francisco, California 94111-3834	Direct Telephone Calls to: (Name, Reg. No., Telephone No.) Name: Gerald T. Gray Reg. No.: 41,797 Telephone: 925-472-5000
--	--

TSVP



(19) **United States**
 (12) **Patent Application Publication** (10) Pub. No.: **US 2002/0169732 A1**
 Pirim (43) Pub. Date: **Nov. 14, 2002**

(54) **METHOD AND DEVICE FOR AUTOMATIC VISUAL PERCEPTION** (30) Foreign Application Priority Data
 Feb. 24, 2000 (FR)..... 00 02355

(76) Inventor: Patrick Pirim, Paris (FR)

Publication Classification

Correspondence Address:
 TOWNSEND AND TOWNSEND AND CREW,
 LLP
 TWO EMBARCADERO CENTER
 EIGHTH FLOOR
 SAN FRANCISCO, CA 94111-3834 (US)

(51) Int. Cl.⁷ G06N 5/00; G06F 17/00
 (52) U.S. Cl. 706/45

(57) **ABSTRACT**

A visual perception processor comprises histogram calculation units, which receive the data DATA(A), DATA(B), ... DATA(E) via a single data bus and supplying classification information to a single time coincidences bus. In a preferred embodiment the histogram calculation units are organized into a matrix.

(21) Appl. No.: 09/792,436
 (22) Filed: Feb. 23, 2001

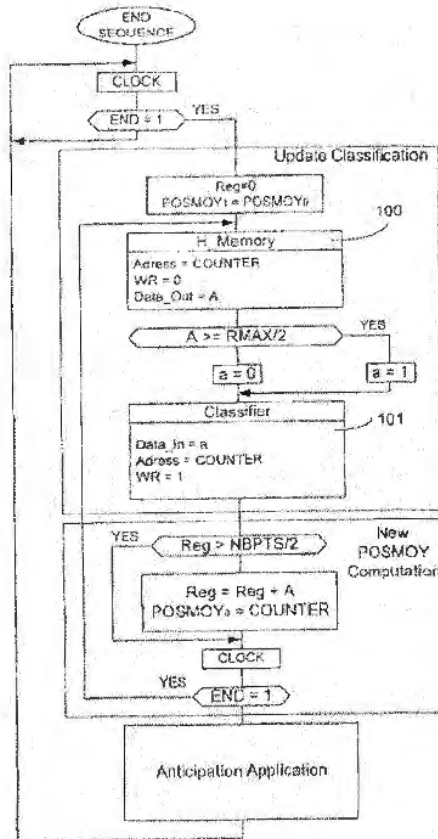



UNITED STATES PATENT AND TRADEMARK OFFICE

UNITED STATES DEPARTMENT OF COMMERCE
United States Patent and Trademark Office
Address: COMMISSIONER FOR PATENTS
P.O. Box 1450
Alexandria, Virginia 22313-1450
www.uspto.gov

APPLICATION NO.	FILING DATE	FIRST NAMED INVENTOR	ATTORNEY DOCKET NO.	CONFIRMATION NO.
09/792,436	02/23/2001	Patrick Pirin	20046H-000100	9956

20350 7590 03/26/2004

TOWNSEND AND TOWNSEND AND CREW, LLP
TWO EMBARCADERO CENTER
EIGHTH FLOOR
SAN FRANCISCO, CA 94111-3834

EXAMINER

DAVIS, GEORGE II

ART UNIT PAPER NUMBER

2121

DATE MAILED: 03/26/2004

Please find below and/or attached an Office communication concerning this application or proceeding.

PPA

Office Action Summary

Application No. 091792436	Applicant(s) Patric Dirim
Examiner George Davis	Group Art Unit 2121

--The MAILING DATE of this communication appears on the cover sheet beneath the correspondence address--

Period for Reply

A SHORTENED STATUTORY PERIOD FOR REPLY IS SET TO EXPIRE Three MONTH(S) FROM THE MAILING DATE OF THIS COMMUNICATION.

- Extensions of time may be available under the provisions of 37 CFR 1.136(a). In no event, however, may a reply be timely filed after SIX (6) MONTHS from the mailing date of this communication.
- If the period for reply specified above is less than thirty (30) days, a reply within the statutory minimum of thirty (30) days will be considered timely.
- If NO period for reply is specified above, such period shall, by default, expire SIX (6) MONTHS from the mailing date of this communication.
- Failure to reply within the set or extended period for reply will, by statute, cause the application to become ABANDONED (35 U.S.C. § 133).

Status

- Responsive to communication(s) filed on _____
- This action is FINAL.
- Since this application is in condition for allowance except for formal matters, prosecution as to the merits is closed in accordance with the practice under *Ex parte Quayle*, 1935 C.D. 11; 453 O.G. 213.

Disposition of Claims

- Claim(s) 1-28 is/are pending in the application.
- Of the above claim(s) _____ is/are withdrawn from consideration.
- Claim(s) 17-28 is/are allowed.
- Claim(s) 1-16 is/are rejected.
- Claim(s) _____ is/are objected to.
- Claim(s) _____ are subject to restriction or election requirement.

Application Papers

- See the attached Notice of Draftsperson's Patent Drawing Review, PTO-948.
- The proposed drawing correction, filed on _____ is approved disapproved.
- The drawing(s) filed on _____ is/are objected to by the Examiner.
- The specification is objected to by the Examiner.
- The oath or declaration is objected to by the Examiner.

Priority under 35 U.S.C. § 119 (a)-(d)

- Acknowledgment is made of a claim for foreign priority under 35 U.S.C. § 119(a)-(d).
- All Some* None of the CERTIFIED copies of the priority documents have been received.
- received in Application No. (Series Code/Serial Number) _____
- received in this national stage application from the International Bureau (PCT Rule 17.2(a)).

*Certified copies not received: _____

Attachment(s)

- Information Disclosure Statement(s), PTO-1449, Paper No(s) 3, 6 and 7
- Notice of Reference(s) Cited, PTO-892
- Notice of Draftsperson's Patent Drawing Review, PTO-948
- Interview Summary, PTO-413
- Notice of Informal Patent Application, PTO-152
- Other _____

Office Action Summary



UNITED STATES PATENT AND TRADEMARK OFFICE

UNITED STATES DEPARTMENT OF COMMERCE
United States Patent and Trademark Office
Address: COMMISSIONER FOR PATENTS
P.O. Box 1450
Alexandria, Virginia 22313-1450
www.uspto.gov

APPLICATION NO.	FILING DATE	FIRST NAMED INVENTOR	ATTORNEY DOCKET NO.	CONFIRMATION NO.
09/792,436	02/23/2001	Patrick Perin	2004611-000100	9936
20390	7590	10/06/2004	EXAMINER	
TOWNSEND AND TOWNSEND AND CREW, LLP TWO EMBARCADERO CENTER EIGHTH FLOOR SAN FRANCISCO, CA 94111-3834			DAVIS, GEORGE B	
			ART UNIT	PAPER NUMBER
			2121	

DATE MAILED: 10/06/2004

Notice of Fee Increase on October 1, 2004

If a reply to a "Notice of Allowance and Fee(s) Due" is filed in the Office on or after October 1, 2004, then the amount due will be higher than that set forth in the "Notice of Allowance and Fee(s) Due" because some fees will increase effective October 1, 2004. See Revision of Patent Fees for Fiscal Year 2005; Final Rule, 69 Fed. Reg. 52604, 52606 (May 10, 2004).

The current fee schedule is accessible from WEB site (<http://www.uspto.gov/main/howtofees.htm>).

If the fee paid is the amount shown on the "Notice of Allowance and Fee(s) Due" but not the correct amount in view of the fee increase, a "Notice of Pay Balance of Issue Fee" will be mailed to applicant. In order to avoid processing delays associated with mailing of a "Notice of Pay Balance of Issue Fee," if the response to the Notice of Allowance is to be filed on or after October 1, 2004 (or mailed with a certificate of mailing on or after October 1, 2004), the issue fee paid should be the fee that is required at the time the fee is paid. See Manual of Patent Examining Procedure (MPEP), Section 1306 (Eighth Edition, Rev. 2, May 2004). If the issue fee was previously paid, and the response to the "Notice of Allowance and Fee(s) Due" includes a request to apply a previously-paid issue fee to the issue fee now due, then the difference between the issue fee amount at the time the response is filed and the previously-paid issue fee should be paid. See MPEP Section 1308.01.

Effective October 1, 2004, 37 CFR 1.18 is amended by revising paragraphs (a) through (c) to read as set forth below.

Section 1.18 Patent post allowance (including issue) fees.

- (a) Issue fee for issuing each original or reissue patent, except a design or plant patent:
 - By a small entity (Sec. 1.27(a))..... \$685.00
 - By other than a small entity..... \$1,370.00
- (b) Issue fee for issuing a design patent:
 - By a small entity (Sec. 1.27(a))..... \$245.00
 - By other than a small entity..... \$490.00
- (c) Issue fee for issuing a plant patent:
 - By a small entity (Sec. 1.27(a))..... \$330.00
 - By other than a small entity..... \$660.00

Questions relating to issue and publication fee payments should be directed to the Customer Service Center of the Office of Patent Publication at (703) 305-8283.

8

Notice of Allowability	Application No.	Applicant(s)	
	09/792,436	PIRIM, PATRICK	
	Examiner	Art Unit	
	George Davis	2121	

-- The MAILING DATE of this communication appears on the cover sheet with the correspondence address--
 All claims being allowable, PROSECUTION ON THE MERITS IS (OR REMAINS) CLOSED in this application. If not included herewith (or previously mailed), a Notice of Allowance (PTOL-85) or other appropriate communication will be mailed in due course. THIS NOTICE OF ALLOWABILITY IS NOT A GRANT OF PATENT RIGHTS. This application is subject to withdrawal from issue at the initiative of the Office or upon petition by the applicant. See 37 CFR 1.313 and MPEP 1308.

1. This communication is responsive to 8/30/2004.
2. The allowed claim(s) is/are 1-29.
3. The drawings filed on _____ are accepted by the Examiner.
4. Acknowledgment is made of a claim for foreign priority under 35 U.S.C. § 119(a)-(d) or (f).
 - a) All b) Some* c) None of the:
 1. Certified copies of the priority documents have been received.
 2. Certified copies of the priority documents have been received in Application No. _____.
 3. Copies of the certified copies of the priority documents have been received in this national stage application from the international Bureau (PCT Rule 17.2(a)).

* Certified copies not received: _____.

Applicant has THREE MONTHS FROM THE "MAILING DATE" of this communication to file a reply complying with the requirements noted below. Failure to timely comply will result in ABANDONMENT of this application. THIS THREE-MONTH PERIOD IS NOT EXTENDABLE.

5. A SUBSTITUTE OATH OR DECLARATION must be submitted. Note the attached EXAMINER'S AMENDMENT or NOTICE OF INFORMAL PATENT APPLICATION (PTO-152) which gives reason(s) why the oath or declaration is deficient.
 6. CORRECTED DRAWINGS (as "replacement sheets") must be submitted.
 - (a) including changes required by the Notice of Draftsperson's Patent Drawing Review (PTO-948) attached
 - 1) hereto or 2) to Paper No./Mail Date _____.
 - (b) including changes required by the attached Examiner's Amendment / Comment or in the Office action of Paper No./Mail Date 3/26/2004.
- Identifying indicia such as the application number (see 37 CFR 1.84(c)) should be written on the drawings in the front (not the back) of each sheet. Replacement sheet(s) should be labeled as such in the header according to 37 CFR 1.121(d).
7. DEPOSIT OF and/or INFORMATION about the deposit of BIOLOGICAL MATERIAL must be submitted. Note the attached Examiner's comment regarding REQUIREMENT FOR THE DEPOSIT OF BIOLOGICAL MATERIAL.

Attachment(s)

- | | |
|---|---|
| <ol style="list-style-type: none"> 1. <input type="checkbox"/> Notice of References Cited (PTO-892) 2. <input type="checkbox"/> Notice of Draftsperson's Patent Drawing Review (PTO-948) 3. <input checked="" type="checkbox"/> Information Disclosure Statements (PTO-1449 or PTO/SB/08),
Paper No./Mail Date <u>8/22/2004</u> 4. <input type="checkbox"/> Examiner's Comment Regarding Requirement for Deposit of Biological Material | <ol style="list-style-type: none"> 5. <input type="checkbox"/> Notice of Informal Patent Application (PTO-152) 6. <input type="checkbox"/> Interview Summary (PTO-413),
Paper No./Mail Date _____ 7. <input type="checkbox"/> Examiner's Amendment/Comment 8. <input type="checkbox"/> Examiner's Statement of Reasons for Allowance 9. <input type="checkbox"/> Other _____ |
|---|---|

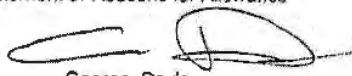
 George Davis
 Primary Examiner
 Art Unit: 2121

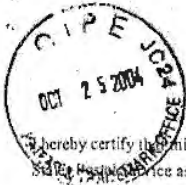

I hereby certify that this correspondence is being deposited with the United States Postal Service as first class mail in an envelope addressed to:

Commissioner for Patents
P.O. Box 1450
Alexandria, VA 22313-1450

PATENT
Attorney Docket No.: 20046H-000100US
Client Ref. No.: 308L US 3772

On October 22, 2004

TOWNSEND and TOWNSEND and CREW LLP

By: Sylvia E. Arnold
Sylvia E. Arnold

IN THE UNITED STATES PATENT AND TRADEMARK OFFICE

In re application of:

Patrick Pirim

Application No.: 09/792,436

Filed: February 23, 2001

For: METHOD AND DEVICE FOR
AUTOMATIC VISUAL PERCEPTION

Customer No.: 20350

Confirmation No. 9956

Examiner: George B. Davis

Technology Center/Art Unit: 2121

COMMUNICATION

Commissioner for Patents
P.O. Box 1450
Alexandria, VA 22313-1450

Sir:

In response to the Notice of Allowability mailed October 6, 2004, Applicants respectfully request issuance of a revised or supplemental Notice for the reasons as discussed herein in the Remarks section.

Remarks/Arguments begin on page 2 of this paper.

REMARKS/ARGUMENTS

A copy of the Notice of Allowability mailed October 6, 2004 is enclosed. In that Notice item 4 indicates that none of the certified copies of the priority documents have been received. The undersigned, however, respectfully asserts that a certified copy of the priority document was filed on August 26, 2004, and was indeed received by the Patent Office as evidenced by its availability through the PAIR website. Correction of this acknowledgement is respectfully requested.

Additionally, item 7 in the Notice indicates that the deposit of biological material is required. It is respectfully assumed that this requirement is erroneous because this application has nothing to do with biological material. Correction of this requirement is also respectfully requested.

Therefore, it is respectfully requested that a revised or supplemental Notice of Allowability be issued, and that the date for payment of the Issue Fee be reset accordingly.

CONCLUSION

In view of the foregoing, the issuance of a revised or supplemental Notice of Allowance at an early date is respectfully requested.

If the Examiner believes a telephone conference would expedite prosecution of this application, please telephone the undersigned at 925-472-5000.

Respectfully submitted,

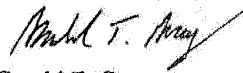

Gerald T. Gray
Reg. No. 41,797

TOWNSEND and TOWNSEND and CREW LLP
Two Embarcadero Center, Eighth Floor
San Francisco, California 94111-3834
Tel: 925-472-5000
Fax: 415-576-0300
Attachments
GTG:sea
60336930 v1



UNITED STATES PATENT AND TRADEMARK OFFICE

UNITED STATES DEPARTMENT OF COMMERCE
United States Patent and Trademark Office
Address: COMMISSIONER FOR PATENTS
P.O. Box 1450
Alexandria, Virginia 22313-1450
www.uspto.gov

APPLICATION NO.	FILING DATE	FIRST NAMED INVENTOR	ATTORNEY DOCKET NO.	CONFIRMATION NO.
09/792,436	02/23/2001	Patrick Pirim	20046H-000100	9956

20350 7590 12/30/2004
TOWNSEND AND TOWNSEND AND CREW, LLP
TWO EMBARCADERO CENTER
EIGHTH FLOOR
SAN FRANCISCO, CA 94111-3834

EXAMINER

DAVIS, GEORGE B

ART UNIT PAPER NUMBER

2121

DATE MAILED: 12/30/2004

Please find below and/or attached an Office communication concerning this application or proceeding.

Supplemental Notice of Allowability	Application No.	Applicant(s)	
	09/792,436	PIRIM, PATRICK	
	Examiner	Art Unit	
	George Davis	2121	

-- The MAILING DATE of this communication appears on the cover sheet with the correspondence address--

All claims being allowable, PROSECUTION ON THE MERITS IS (OR REMAINS) CLOSED in this application. If not included herewith (or previously mailed), a Notice of Allowance (PTOL-85) or other appropriate communication will be mailed in due course. **THIS NOTICE OF ALLOWABILITY IS NOT A GRANT OF PATENT RIGHTS.** This application is subject to withdrawal from issue at the initiative of the Office or upon petition by the applicant. See 37 CFR 1.313 and MPEP 1308.

1. This communication is responsive to _____.
2. The allowed claim(s) is/are 1-29.
3. The drawings filed on _____ are accepted by the Examiner.
4. Acknowledgment is made of a claim for foreign priority under 35 U.S.C. § 119(a)-(d) or (f).
 - a) All b) Some* c) None of the:
 1. Certified copies of the priority documents have been received.
 2. Certified copies of the priority documents have been received in Application No. _____.
 3. Copies of the certified copies of the priority documents have been received in this national stage application from the International Bureau (PCT Rule 17.2(a)).

* Certified copies not received: _____.

Applicant has THREE MONTHS FROM THE "MAILING DATE" of this communication to file a reply complying with the requirements noted below. Failure to timely comply will result in ABANDONMENT of this application. **THIS THREE-MONTH PERIOD IS NOT EXTENDABLE.**

5. A SUBSTITUTE OATH OR DECLARATION must be submitted. Note the attached EXAMINER'S AMENDMENT or NOTICE OF INFORMAL PATENT APPLICATION (PTO-152) which gives reason(s) why the oath or declaration is deficient.
6. CORRECTED DRAWINGS (as "replacement sheets") must be submitted.
 - (a) including changes required by the Notice of Draftsperson's Patent Drawing Review (PTO-948) attached
 - 1) hereto or 2) to Paper No./Mail Date _____.
 - (b) including changes required by the attached Examiner's Amendment / Comment or in the Office action of Paper No./Mail Date 3/26/2004.

Identifying indicia such as the application number (see 37 CFR 1.84(c)) should be written on the drawings in the front (not the back) of each sheet. Replacement sheet(s) should be labeled as such in the header according to 37 CFR 1.121(d).
7. DEPOSIT OF and/or INFORMATION about the deposit of BIOLOGICAL MATERIAL must be submitted. Note the attached Examiner's comment regarding REQUIREMENT FOR THE DEPOSIT OF BIOLOGICAL MATERIAL.

Attachment(s)

<ol style="list-style-type: none"> 1. <input type="checkbox"/> Notice of References Cited (PTO-892) 2. <input type="checkbox"/> Notice of Draftsperson's Patent Drawing Review (PTO-948) 3. <input type="checkbox"/> Information Disclosure Statements (PTO-1449 or PTO/SB/08), Paper No./Mail Date _____ 4. <input type="checkbox"/> Examiner's Comment Regarding Requirement for Deposit of Biological Material 	<ol style="list-style-type: none"> 5. <input type="checkbox"/> Notice of Informal Patent Application (PTO-152) 6. <input checked="" type="checkbox"/> Interview Summary (PTO-413), Paper No./Mail Date <u>12/27/2004</u>. 7. <input type="checkbox"/> Examiner's Amendment/Comment 8. <input type="checkbox"/> Examiner's Statement of Reasons for Allowance 9. <input type="checkbox"/> Other _____
---	---

 George Davis
 Primary Examiner
 Art Unit: 2121



United States Patent and Trademark Office

Home | Site Index | Search | FAQ | Glossary | Office | Contacts | eBusiness | Public Notices | News | Help

Portal Home | Patents | Trademarks | Other

Patent eBusiness

Patent Application Information Services

- Electronic Filing
- Patent Application Information (PAIR)
- Patent Ownership
- Fees
- Supplemental Resources & Support

Patent Information

Patent Guidance and General Info

- Codes, Rules & Manuals
- Employee & Office Directories
- Resources & Public Notices

Patent Resources

Patent Official Gazette

- Search Patents & Applications
- Search Biological Sequences
- Copies, Products & Services

Other

- Copyrights
- Trademarks
- Policy & Law
- Records

You can suggest USPTO webpages or material you would like featured on this section by E-mail to the webmaster@uspto.gov. While we cannot promise to accommodate all requests, your suggestions will be considered and may lead to other improvements on the website.

Home | Site Index | Search | eBusiness | Office | Privacy Policy

Order: 1364 Application: 01-1107 Order: 01/11/01 Order: 01/11/01

01/11/01 430 METHOD AND DEVICE FOR AUTOMATIC VISUAL PERCEPTION

Search	Application	Transaction	Image File	Patent Term	Continuity	Foreign	Fees	Published	Address 3
New Case	Data	History	Wrapper	Adjustments	Data	Priority		Documents	Attorney/Agent

Foreign Priority

Country	Priority	Priority Date
FRANCE	00 02355	02-24-2000

If you need help:

- Call the Patent Electronic Business Center at (866) 217-9197 (toll free) or e-mail fe@uspto.gov for specific questions about Patent Application Information Retrieval (PAIR).
- Send general questions about USPTO programs to the [USPTO Contact Center \(USPTO\)](mailto:USPTO.Contact.Center@uspto.gov).
- If you experience technical difficulties or problems with this application, please report them via e-mail to fe@uspto.gov or call 1-800-785-9199.



UNITED STATES PATENT AND TRADEMARK OFFICE

UNITED STATES DEPARTMENT OF COMMERCE
United States Patent and Trademark Office
Address: COMMISSIONER FOR PATENTS
P.O. Box 1459
Alexandria, Virginia 22313-1450
www.uspto.gov

APPLICATION NO.	FILING DATE	FIRST NAMED INVENTOR	ATTORNEY DOCKET NO.	CONFIRMATION NO.
09/192,436	02/23/2001	Patrick Finn	2004631-000100	9956
20350	7590	04/27/2005	EXAMINER	
TOWNSEND AND TOWNSEND AND CREW, LLP TWO EMBARCADERO CENTER EIGHTH FLOOR SAN FRANCISCO, CA 94111-3834			DAVIS, GEORGE B	
			ART UNIT	PAPER NUMBER
			2121	

DATE MAILED: 04/27/2005

Please find below and/or attached an Office communication concerning this application or proceeding.

Supplemental Notice of Allowability	Application No.	Applicant(s)	
	09/792,436	PIRIM, PATRICK	
	Examiner	Art Unit	
	George Davis	2121	

-- The MAILING DATE of this communication appears on the cover sheet with the correspondence address--

All claims being allowable, PROSECUTION ON THE MERITS IS (OR REMAINS) CLOSED in this application. If not included herewith (or previously mailed), a Notice of Allowance (PTOL-85) or other appropriate communication will be mailed in due course. **THIS NOTICE OF ALLOWABILITY IS NOT A GRANT OF PATENT RIGHTS.** This application is subject to withdrawal from issue at the initiative of the Office or upon petition by the applicant. See 37 CFR 1.313 and MPEP 1308.

1. This communication is responsive to 1/18/05.
2. The allowed claim(s) is/are 1-29.
3. The drawings filed on 18 January 2005 are accepted by the Examiner.
4. Acknowledgment is made of a claim for foreign priority under 35 U.S.C. § 119(a)-(d) or (f)
 - a) All b) Some* c) None of the:
 1. Certified copies of the priority documents have been received.
 2. Certified copies of the priority documents have been received in Application No. _____.
 3. Copies of the certified copies of the priority documents have been received in this national stage application from the International Bureau (PCT Rule 17.2(a)).

* Certified copies not received: _____.

Applicant has THREE MONTHS FROM THE "MAILING DATE" of this communication to file a reply complying with the requirements noted below. Failure to timely comply will result in ABANDONMENT of this application. **THIS THREE-MONTH PERIOD IS NOT EXTENDABLE.**

5. A SUBSTITUTE OATH OR DECLARATION must be submitted. Note the attached EXAMINER'S AMENDMENT or NOTICE OF INFORMAL PATENT APPLICATION (PTO-152) which gives reason(s) why the oath or declaration is deficient.
6. CORRECTED DRAWINGS (as "replacement sheets") must be submitted.
 - (a) including changes required by the Notice of Draftsperson's Patent Drawing Review (PTO-948) attached
 - 1) hereto or 2) to Paper No./Mail Date _____.
 - (b) including changes required by the attached Examiner's Amendment / Comment or in the Office action of Paper No./Mail Date _____.

Identifying indicia such as the application number (see 37 CFR 1.84(c)) should be written on the drawings in the front (not the back) of each sheet. Replacement sheet(s) should be labeled as such in the header according to 37 CFR 1.121(d).
7. DEPOSIT OF and/or INFORMATION about the deposit of BIOLOGICAL MATERIAL must be submitted. Note the attached Examiner's comment regarding REQUIREMENT FOR THE DEPOSIT OF BIOLOGICAL MATERIAL.

Attachment(s)

- | | |
|--|---|
| <ol style="list-style-type: none"> 1. <input type="checkbox"/> Notice of References Cited (PTO-892) 2. <input type="checkbox"/> Notice of Draftsperson's Patent Drawing Review (PTO-948) 3. <input checked="" type="checkbox"/> Information Disclosure Statements (PTO-1449 or PTO/SB/08), Paper No./Mail Date <u>04252005</u> 4. <input type="checkbox"/> Examiner's Comment Regarding Requirement for Deposit of Biological Material | <ol style="list-style-type: none"> 5. <input type="checkbox"/> Notice of Informal Patent Application (PTO-152) 6. <input checked="" type="checkbox"/> Interview Summary (PTO-413), Paper No./Mail Date <u>04252005</u> 7. <input checked="" type="checkbox"/> Examiner's Amendment/Comment 8. <input type="checkbox"/> Examiner's Statement of Reasons for Allowance 9. <input type="checkbox"/> Other _____ |
|--|---|

GEORGE B. DAVIS
 PRIMARY EXAMINER

**UNITED STATES PATENT AND TRADEMARK OFFICE
CERTIFICATE OF CORRECTION**

Page 1 of 1

PATENT NO. : 6,959,293 B2
APPLICATION NO.: 09/792,436
ISSUE DATE : October 25, 2005
INVENTOR(S) : Patrick Pirim

It is certified that an error appears or errors appear in the above-identified patent and that said Letters Patent is hereby corrected as shown below:

To the first page of the patent, below the Prior Publication Data section, please add the following section --

(30) Foreign Application Priority Data
Feb. 24, 2000 (FR) 00 02355 --.

In the drawings, Sheet 31, Fig. 40, replace each occurrence of "Apprentissage" with --Learning-- and replace "Classification automatique" with --Automatic Classification--.

Column 1, line 13, replace "and is particularly useful" with --and are particularly usefut--.

Column 26, line 44, please add a semi-colon after "a control unit" to read --a control unit;--.

Column 27, lines 5-6, replace "two or more histogram calculation unit" with --two or more histogram calculation units--; line 16, replace "said unit" with --said at least one calculation unit--; line 66, replace "End" with --END--.

MAILING ADDRESS OF SENDER (Please do not use customer number below):

Novak Druce + Quigg LLP
525 Okeechobee Boulevard, 15th Floor
West Palm Beach, FL 33401

This collection of information is required by 37 CFR 1.322, 1.323, and 1.324. The information is required to obtain or retain a benefit by the public which is to file (and by the USPTO to process) an application. Confidentiality is governed by 35 U.S.C. 122 and 37 CFR 1.14. This collection is estimated to take 1.0 hour to complete, including gathering, preparing, and submitting the completed application form to the USPTO. Time will vary depending upon the individual case. Any comments on the amount of time you require to complete this form and/or suggestions for reducing this burden, should be sent to the Chief Information Officer, U.S. Patent and Trademark Office, U.S. Department of Commerce, P.O. Box 1450, Alexandria, VA 22313-1450. DO NOT SEND FEES OR COMPLETED FORMS TO THIS ADDRESS. SEND TO: **Attention Certificate of Corrections Branch, Commissioner for Patents, P.O. Box 1450, Alexandria, VA 22313-1450.**

If you need assistance in completing the form, call 1-800-PTO-9199 and select option 2.

Electronic Patent Application Fee Transmittal

Application Number:	09792436
Filing Date:	23-Feb-2001
Title of Invention:	METHOD AND DEVICE FOR AUTOMATIC VISUAL PERCEPTION
First Named Inventor/Applicant Name:	Patrick Pirim
Filer:	Gregory A. Nelson/TJ FATUM
Attorney Docket Number:	20046H-000100

Filed as Large Entity

Utility under 35 USC 111(a) Filing Fees

Description	Fee Code	Quantity	Amount	Sub-Total in USD(\$)
Basic Filing:				
Pages:				
Claims:				
Miscellaneous-Filing:				
Petition:				
Patent-Appeals-and-Interference:				
Post-Allowance-and-Post-Issuance:				
Certificate of correction	1811	1	100	100

Extension-of-Time:

Description	Fee Code	Quantity	Amount	Sub-Total in USD(\$)
Miscellaneous:				
Total in USD (\$)				100

Electronic Acknowledgement Receipt

EFS ID:	8257029
Application Number:	09792436
International Application Number:	
Confirmation Number:	9956
Title of Invention:	METHOD AND DEVICE FOR AUTOMATIC VISUAL PERCEPTION
First Named Inventor/Applicant Name:	Patrick Pirim
Customer Number:	20350
Filer:	Gregory A. Nelson/TJ FATUM
Filer Authorized By:	Gregory A. Nelson
Attorney Docket Number:	20046H-000100
Receipt Date:	20-AUG-2010
Filing Date:	23-FEB-2001
Time Stamp:	13:03:55
Application Type:	Utility under 35 USC 111(a)

Payment information:

Submitted with Payment	yes
Payment Type	Credit Card
Payment was successfully received in RAM	\$100
RAM confirmation Number	6693
Deposit Account	141437
Authorized User	KLINE,KAREN

The Director of the USPTO is hereby authorized to charge indicated fees and credit any overpayment as follows:

Charge any Additional Fees required under 37 C.F.R. Section 1.16 (National application filing, search, and examination fees)

Charge any Additional Fees required under 37 C.F.R. Section 1.17 (Patent application and reexamination processing fees)

Charge any Additional Fees required under 37 C.F.R. Section 1.19 (Document supply fees)
 Charge any Additional Fees required under 37 C.F.R. Section 1.20 (Post Issuance fees)
 Charge any Additional Fees required under 37 C.F.R. Section 1.21 (Miscellaneous fees and charges)

File Listing:

Document Number	Document Description	File Name	File Size(Bytes)/ Message Digest	Multi Part /.zip	Pages (if appl.)
1	Assignee showing of ownership per 37 CFR 3.73(b).	8042-5_STATEMENT.pdf	243438	no	2
			3d4d7a687df0a54c68daa2d7d312761b5de22ea6		
Warnings:					
Information:					
2		8042-5_COC_081910.pdf	3230969	yes	20
			c24f8f6b37f1eb776f0ca4cba48db0d0c2e2ae9c		
Multipart Description/PDF files in .zip description					
		Document Description	Start	End	
		Power of Attorney	1	1	
		Request for Certificate of Correction	2	19	
		Request for Certificate of Correction	20	20	
Warnings:					
Information:					
3	Fee Worksheet (PTO-875)	fee-info.pdf	30078	no	2
			07836b4d54e64bcff672c2c12a49ffb123508665		
Warnings:					
Information:					
Total Files Size (in bytes):			3504485		

This Acknowledgement Receipt evidences receipt on the noted date by the USPTO of the indicated documents, characterized by the applicant, and including page counts, where applicable. It serves as evidence of receipt similar to a Post Card, as described in MPEP 503.

New Applications Under 35 U.S.C. 111

If a new application is being filed and the application includes the necessary components for a filing date (see 37 CFR 1.53(b)-(d) and MPEP 506), a Filing Receipt (37 CFR 1.54) will be issued in due course and the date shown on this Acknowledgement Receipt will establish the filing date of the application.

National Stage of an International Application under 35 U.S.C. 371

If a timely submission to enter the national stage of an international application is compliant with the conditions of 35 U.S.C. 371 and other applicable requirements a Form PCT/DO/EO/903 indicating acceptance of the application as a national stage submission under 35 U.S.C. 371 will be issued in addition to the Filing Receipt, in due course.

New International Application Filed with the USPTO as a Receiving Office

If a new international application is being filed and the international application includes the necessary components for an international filing date (see PCT Article 11 and MPEP 1810), a Notification of the International Application Number and of the International Filing Date (Form PCT/RO/105) will be issued in due course, subject to prescriptions concerning national security, and the date shown on this Acknowledgement Receipt will establish the international filing date of the application.

Under the Paperwork Reduction Act of 1995, no persons are required to respond to a collection of information unless it displays a valid OMB control number.

STATEMENT UNDER 37 CFR 3.73(b)

Applicant/Patent Owner: PIRIM

Application No./Patent No.: 6,959,293 Filed/Issue Date: OCTOBER 25, 2005

Titled: METHOD AND DEVICE FOR AUTOMATIC VISUAL PERCEPTION

IMAGE PROCESSING TECHNOLOGIES LLC, a CORPORATION

(Name of Assignee) (Type of Assignee, e.g., corporation, partnership, university, government agency, etc.)

states that it is:

- 1. the assignee of the entire right, title, and interest in;
 - 2. an assignee of less than the entire right, title, and interest in
(The extent (by percentage) of its ownership interest is _____ %); or
 - 3. the assignee of an undivided interest in the entirety of (a complete assignment from one of the joint inventors was made)
- the patent application/patent identified above, by virtue of either:

A. An assignment from the inventor(s) of the patent application/patent identified above. The assignment was recorded in the United States Patent and Trademark Office at Reel _____, Frame _____, or for which a copy therefore is attached.

OR

B. A chain of title from the inventor(s), of the patent application/patent identified above, to the current assignee as follows:

1. From: PIRIM To: HOLDING B.E.V.S.A.

The document was recorded in the United States Patent and Trademark Office at
Reel 012489, Frame 0149, or for which a copy thereof is attached.

2. From: HOLDING B.E.V.S.A. ET AL. To: U.S. DISTRICT COURT, S.D.FL

The document was recorded in the United States Patent and Trademark Office at
Reel 015622, Frame 0159, or for which a copy thereof is attached.

3. From: U.S. DISTRICT COURT, S.D.FL To: BROWN

The document was recorded in the United States Patent and Trademark Office at
Reel 017057, Frame 0179, or for which a copy thereof is attached.

Additional documents in the chain of title are listed on a supplemental sheet(s).

As required by 37 CFR 3.73(b)(1)(i), the documentary evidence of the chain of title from the original owner to the assignee was, or concurrently is being, submitted for recordation pursuant to 37 CFR 3.11.

[NOTE: A separate copy (i.e., a true copy of the original assignment document(s)) must be submitted to Assignment Division in accordance with 37 CFR Part 3, to record the assignment in the records of the USPTO. See MPEP 302.08]

The undersigned (whose title is supplied below) is authorized to act on behalf of the assignee.

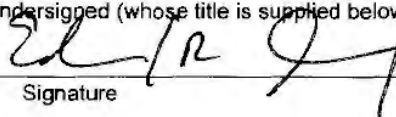

Signature

B. 20. 10

Date

Ed Gomez

Printed or Typed Name

Chief IP Counsel, General Patent Corp. / General Patent Corp. is Manager, Image Processing Technologies LLC

Title

This collection of information is required by 37 CFR 3.73(b). The information is required to obtain or retain a benefit by the public which is to file (and by the USPTO to process) an application. Confidentiality is governed by 35 U.S.C. 122 and 37 CFR 1.11 and 1.14. This collection is estimated to take 12 minutes to complete, including gathering, preparing, and submitting the completed application form to the USPTO. Time will vary depending upon the individual case. Any comments on the amount of time you require to complete this form and/or suggestions for reducing this burden, should be sent to the Chief Information Officer, U.S. Patent and Trademark Office, U.S. Department of Commerce, P.O. Box 1450, Alexandria, VA 22313-1450. DO NOT SEND FEES OR COMPLETED FORMS TO THIS ADDRESS. SEND TO: Commissioner for Patents, P.O. Box 1450, Alexandria, VA 22313-1450.

If you need assistance in completing the form, call 1-800-PTO-9199 and select option 2.

STATEMENT UNDER 37 CFR 3.73(b) (Page 2 of 2)

Applicant/Patent Owner: PIRIM

Application No./Patent No.: 6,959,293

Filed/Issue Date: OCTOBER 25, 2005

Titled: METHOD AND DEVICE FOR AUTOMATIC VISUAL PERCEPTION

IMAGE PROCESSING TECHNOLOGIES LLC, a CORPORATION

(Name of Assignee)

(Type of Assignee, e.g., corporation, partnership, university, government agency, etc)

From: U.S. DISTRICT COURT, S.D.FL

To: BROWN

The document was recorded in the United States Patent and Trademark Office at

Reel 017057, Frame 0511, or for which a copy thereof is attached.

From: BROWN

To: IMAGE PROCESSING TECHNOLOGIES LLC

The document was recorded in the United States Patent and Trademark Office at

Reel 023409, Frame 0987, or for which a copy thereof is attached.

From: _____

To: _____

The document was recorded in the United States Patent and Trademark Office at

Reel _____, Frame _____, or for which a copy thereof is attached.

IN THE UNITED STATES PATENT AND TRADEMARK OFFICE

In re: Application of	PIRIM	Confirmation No.	9956
Patent No.	6,959,293	Group:	2121
Application No.	09/792,436	Examiner:	Davis, George B
Filing Date:	February 23, 2001	Docket No.	8042-5

For: METHOD AND DEVICE FOR AUTOMATIC VISUAL PERCEPTION

ASSERTION OF SMALL ENTITY STATUS UNDER 37 C.F.R. §1.27

Mail Stop 16
Director of the U.S. Patent and Trademark Office
P.O. Box 1450
Alexandria, VA 22313

Sir:

Applicants request that the entity status of the above-referenced application be corrected to reflect entitlement to small entity fees due to a transfer of ownership of the application. The current assignee of the application is entitled to small entity status under 37 C.F.R. §1.27(a) and was entitled to small entity status on September 22, 2009 when the 3.5 year maintenance fee and surcharge were paid.

Please contact the undersigned if clarification is needed.

Respectfully submitted,

Dated: December 10, 2009

By:

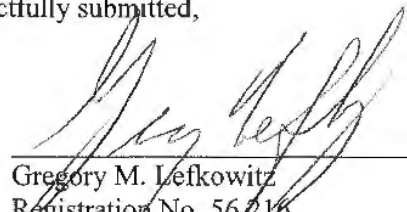

Gregory M. Lefkowitz
Registration No. 56,216
NOVAK DRUCE + QUIGG LLP
525 Okeechobee Blvd, 15th Floor
West Palm Beach, FL 33401
Phone: 561-847-7800
Fax: 561-847-7801

IN THE UNITED STATES PATENT AND TRADEMARK OFFICE

In re: Application of	PIRIM	Confirmation No.	9956
Patent No.	6,959,293	Group:	2121
Application No.	09/792,436	Examiner:	Davis, George B
Filing Date:	February 23, 2001	Docket No.	8042-5

For: METHOD AND DEVICE FOR AUTOMATIC VISUAL PERCEPTION

REQUEST FOR REFUND

Mail Stop 16
Director of the U.S. Patent and Trademark Office
P.O. Box 1450
Alexandria, VA 22313

Dear Sir:

On September 22, 2009, the undersigned submitted a payment of \$1110.00 for the maintenance fee and surcharge for late payment in regard to the above-referenced patent. The large entity fees were mistakenly paid; however, the undersigned was later advised that the Assignee in this matter qualified for small entity status at the time of payment. Accordingly, pursuant to 37 C.F.R. 1.28, a refund in the total amount of \$555.00 is requested as follows:

Maintenance Fee:	\$490.00
Late Payment Surcharge:	\$65.00
Total:	\$555.00

As this request is being filed less than three months after payment of the fee, this request for refund is timely. The Director of the U.S. Patent and Trademark Office is hereby authorized to credit the refund to the Credit Card on file for this case.

Please contact the undersigned if there are any questions or if further clarification is needed.

Respectfully submitted,

NOVAK DRUCE + QUIGG LLP

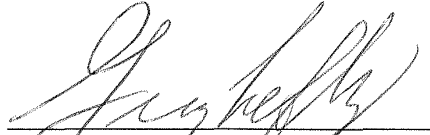
A handwritten signature in black ink, appearing to read "Gregory M. Lefkowitz", written over a horizontal line.

Date: December 10, 2009

Gregory M. Lefkowitz
Registration No. 56,216
NOVAK DRUCE + QUIGG LLP
525 Okeechobee Blvd, 15th Floor
West Palm Beach, FL 33401
Phone: 561-847-7800
Fax: 561-847-7801

Electronic Acknowledgement Receipt

EFS ID:	6611136
Application Number:	09792436
International Application Number:	
Confirmation Number:	9956
Title of Invention:	METHOD AND DEVICE FOR AUTOMATIC VISUAL PERCEPTION
First Named Inventor/Applicant Name:	Patrick Pirim
Customer Number:	20350
Filer:	Gregory Marc Lefkowitz/Nani Kim
Filer Authorized By:	Gregory Marc Lefkowitz
Attorney Docket Number:	20046H-000100
Receipt Date:	10-DEC-2009
Filing Date:	23-FEB-2001
Time Stamp:	14:58:07
Application Type:	Utility under 35 USC 111(a)

Payment information:

Submitted with Payment	no
------------------------	----

File Listing:

Document Number	Document Description	File Name	File Size(Bytes)/ Message Digest	Multi Part /.zip	Pages (if appl.)
1	Miscellaneous Incoming Letter	8042_5_SmallEntityStatus.pdf	109847 125bf8d61944a891d3b1b28ac58b4885c6a6ad54	no	1

Warnings:

Information:

2	Refund Request	8042_5_RequestRefund.pdf	154289	no	2
			27297ccfe421d4eb330feaca50683ed8a7c403ea		

Warnings:

Information:

Total Files Size (in bytes):	264136
-------------------------------------	--------

This Acknowledgement Receipt evidences receipt on the noted date by the USPTO of the indicated documents, characterized by the applicant, and including page counts, where applicable. It serves as evidence of receipt similar to a Post Card, as described in MPEP 503.

New Applications Under 35 U.S.C. 111

If a new application is being filed and the application includes the necessary components for a filing date (see 37 CFR 1.53(b)-(d) and MPEP 506), a Filing Receipt (37 CFR 1.54) will be issued in due course and the date shown on this Acknowledgement Receipt will establish the filing date of the application.

National Stage of an International Application under 35 U.S.C. 371

If a timely submission to enter the national stage of an international application is compliant with the conditions of 35 U.S.C. 371 and other applicable requirements a Form PCT/DO/EO/903 indicating acceptance of the application as a national stage submission under 35 U.S.C. 371 will be issued in addition to the Filing Receipt, in due course.

New International Application Filed with the USPTO as a Receiving Office

If a new international application is being filed and the international application includes the necessary components for an international filing date (see PCT Article 11 and MPEP 1810), a Notification of the International Application Number and of the International Filing Date (Form PCT/RO/105) will be issued in due course, subject to prescriptions concerning national security, and the date shown on this Acknowledgement Receipt will establish the international filing date of the application.



UNITED STATES PATENT AND TRADEMARK OFFICE

UNITED STATES DEPARTMENT OF COMMERCE
United States Patent and Trademark Office
Address: COMMISSIONER FOR PATENTS
P.O. Box 1450
Alexandria, Virginia 22313-1450
www.uspto.gov

APPLICATION NO.	FILING DATE	FIRST NAMED INVENTOR	ATTORNEY DOCKET NO.	CONFIRMATION NO.
09/792,436	02/23/2001	Patrick Pirim	20046H-000100	9956
20350	7590	04/27/2005	EXAMINER	
TOWNSEND AND TOWNSEND AND CREW, LLP TWO EMBARCADERO CENTER EIGHTH FLOOR SAN FRANCISCO, CA 94111-3834			DAVIS, GEORGE B	
			ART UNIT	PAPER NUMBER
			2121	

DATE MAILED: 04/27/2005

Please find below and/or attached an Office communication concerning this application or proceeding.

**Supplemental
Notice of Allowability**

Application No.

09/792,436

Examiner

George Davis

Applicant(s)

PIRIM, PATRICK

Art Unit

2121

-- The MAILING DATE of this communication appears on the cover sheet with the correspondence address--

All claims being allowable, PROSECUTION ON THE MERITS IS (OR REMAINS) CLOSED in this application. If not included herewith (or previously mailed), a Notice of Allowance (PTOL-85) or other appropriate communication will be mailed in due course. **THIS NOTICE OF ALLOWABILITY IS NOT A GRANT OF PATENT RIGHTS.** This application is subject to withdrawal from issue at the initiative of the Office or upon petition by the applicant. See 37 CFR 1.313 and MPEP 1308.

1. This communication is responsive to 1/18/05.
2. The allowed claim(s) is/are 1-29.
3. The drawings filed on 18 January 2005 are accepted by the Examiner.
4. Acknowledgment is made of a claim for foreign priority under 35 U.S.C. § 119(a)-(d) or (f).
 - a) All b) Some* c) None of the:
 1. Certified copies of the priority documents have been received.
 2. Certified copies of the priority documents have been received in Application No. _____.
 3. Copies of the certified copies of the priority documents have been received in this national stage application from the International Bureau (PCT Rule 17.2(a)).

* Certified copies not received: _____.

Applicant has THREE MONTHS FROM THE "MAILING DATE" of this communication to file a reply complying with the requirements noted below. Failure to timely comply will result in ABANDONMENT of this application.
THIS THREE-MONTH PERIOD IS NOT EXTENDABLE.

5. A SUBSTITUTE OATH OR DECLARATION must be submitted. Note the attached EXAMINER'S AMENDMENT or NOTICE OF INFORMAL PATENT APPLICATION (PTO-152) which gives reason(s) why the oath or declaration is deficient.
6. CORRECTED DRAWINGS (as "replacement sheets") must be submitted.
 - (a) including changes required by the Notice of Draftsperson's Patent Drawing Review (PTO-948) attached
 - 1) hereto or 2) to Paper No./Mail Date _____.
 - (b) including changes required by the attached Examiner's Amendment / Comment or in the Office action of Paper No./Mail Date _____.

Identifying indicia such as the application number (see 37 CFR 1.84(c)) should be written on the drawings in the front (not the back) of each sheet. Replacement sheet(s) should be labeled as such in the header according to 37 CFR 1.121(d).
7. DEPOSIT OF and/or INFORMATION about the deposit of BIOLOGICAL MATERIAL must be submitted. Note the attached Examiner's comment regarding REQUIREMENT FOR THE DEPOSIT OF BIOLOGICAL MATERIAL.

Attachment(s)

1. Notice of References Cited (PTO-892)
2. Notice of Draftsperson's Patent Drawing Review (PTO-948)
3. Information Disclosure Statements (PTO-1449 or PTO/SB/08),
Paper No./Mail Date 04252005
4. Examiner's Comment Regarding Requirement for Deposit
of Biological Material
5. Notice of Informal Patent Application (PTO-152)
6. Interview Summary (PTO-413),
Paper No./Mail Date 04252005.
7. Examiner's Amendment/Comment
8. Examiner's Statement of Reasons for Allowance
9. Other _____.

**GEORGE B. DAVIS
PRIMARY EXAMINER**

Examiner's Amendment

1. An examiner's amendment to the record appears below. Should the changes and/or additions be unacceptable to applicant, an amendment may be filed as provided by 37 CFR 1.312. To ensure consideration of such an amendment, it MUST be submitted no later than the payment of the issue fee.

IN THE CLAIMS

Claim 29, line 2, after "matrix" insert -- . --.

2. Authorization for this examiner's amendment was given in a telephone interview with Gerald T. Gray on April 22, 2005.

please enter
4/25/05
G.D.

G. Davis
G.D.
April 25, 2005



**GEORGE B. DAVIS
PRIMARY EXAMINER**

Examiner-Initiated Interview Summary	Application No. 09/792,436	Applicant(s) PIRIM, PATRICK	
	Examiner George Davis	Art Unit 2121	

All Participants:

(1) George Davis.

(2) Gerald T. Gray.

Status of Application: _____

(3) _____.

(4) _____.

Date of Interview: _____

Time: _____

Type of Interview:

- Telephonic
- Video Conference
- Personal (Copy given to: Applicant Applicant's representative)

Exhibit Shown or Demonstrated: Yes No
If Yes, provide a brief description:

Part I.

Rejection(s) discussed:

Claims discussed:

Prior art documents discussed:

Part II.

SUBSTANCE OF INTERVIEW DESCRIBING THE GENERAL NATURE OF WHAT WAS DISCUSSED:
See Examiner's Amendment.

Part III.

- It is not necessary for applicant to provide a separate record of the substance of the interview, since the interview directly resulted in the allowance of the application. The examiner will provide a written summary of the substance of the interview in the Notice of Allowability.
- It is not necessary for applicant to provide a separate record of the substance of the interview, since the interview did not result in resolution of all issues. A brief summary by the examiner appears in Part II above.

(Examiner/SPE Signature)

(Applicant/Applicant's Representative Signature – if appropriate)



Substitute for form 1449A/PTO		Complete if Known	
INFORMATION DISCLOSURE STATEMENT BY APPLICANT <i>(use as many sheets as necessary)</i>		Application Number	09/792,436
		Filing Date	February 23, 2001
		First Named Inventor	Pirim, Patrick
		Art Unit	2121
		Examiner Name	George B. Davis
Sheet 1 of 1	Attorney Docket Number	20046H-000100US	

U.S. PATENT DOCUMENTS+							
Examiner Initials*	Cite No. ¹	Document Number		Publication Date MM-DD-YYYY	Name of Patentee or Applicant of Cited Document	class <small>Pages, Columns, Lines, Where Relevant Passages or Relevant Figures Appear</small>	subclass <small>Where Relevant Passages or Relevant Figures Appear</small>
		Number	Kind Code ² (if known)				
C.D.	1	4,783,828		11-08-1988	Sadjadi	382	170
C.D.	2	5,278,921 A		01-11-1994	Nakamura et al.	382	167
C.D.	3	5,774,581 A		06-30-1998	Fassnacht et al.	382	180
C.D.	4	6,597,738 B1		07-22-2003	Park et al.	375	240.16

FOREIGN PATENT DOCUMENTS								
Examiner Initials*	Cite No. ¹	Foreign Patent Document			Publication Date MM-DD-YYYY	Name of Patentee or Applicant of Cited Document	Pages, Columns, Lines, Where Relevant Passages or Relevant Figures Appear	T
		Country Code ²	Number ³	Kind Code ⁴ (if known)				
C.D.	5	JP	06-205780	A	07-26-1994	Aloka Co. Ltd.		<input type="checkbox"/>
								<input type="checkbox"/>
								<input type="checkbox"/>
								<input type="checkbox"/>
								<input type="checkbox"/>
								<input type="checkbox"/>
								<input type="checkbox"/>

Examiner Signature	<i>George Davis</i>	Date Considered	<i>4/18/05</i>
--------------------	---------------------	-----------------	----------------

*EXAMINER: Initial if reference considered, whether or not citation is in conformance with MPEP 809. Draw line through citation if not in conformance and not considered. Include copy of this form with next communication to applicant. ¹ Applicant's unique citation designation number (optional). ² Kind Codes of U.S. Patent Documents at www.uspto.gov or MPEP 901.04. ³ Enter Office that issued the document, by the two-letter code (WIPO Standard ST.3). ⁴ For Japanese patent documents, the indication of the year of the reign of the Emperor must precede the serial number of the patent document. ⁵ Kind of document by the appropriate symbols as indicated on the document under WIPO Standard ST. 18 if possible. ⁶ Applicant is to place a check mark here if English language Translation is attached.
60342657 v1

● PRINTER RUSH ●
(PTO ASSISTANCE)

Application : <u>09/792436</u>	Examiner : <u>Davis</u>	GAU : <u>2121</u>
From : <u>T. McGill</u>	Location : <u>IDC</u> FMF FDC	Date : <u>2-22-05</u>

Tracking #: 6002350 Week Date: 1-3-05

DOC CODE	DOC DATE	MISCELLANEOUS
<input type="checkbox"/> 1449		<input type="checkbox"/> Continuing Data
<input checked="" type="checkbox"/> IDS	<u>11-1-04</u>	<input type="checkbox"/> Foreign Priority
<input checked="" type="checkbox"/> CLM	<u>8-30-04</u>	<input type="checkbox"/> Document Legibility
<input type="checkbox"/> IIFW		<input type="checkbox"/> Fees
<input type="checkbox"/> SRFW		<input type="checkbox"/> Other
<input type="checkbox"/> DRW		
<input type="checkbox"/> OATH		
<input type="checkbox"/> 312		
<input type="checkbox"/> SPEC		

[RUSH] MESSAGE: ① PTO-1449 - Please initial/line through citation.

② Patent claim 17 (original claim 29) is incomplete. It does not end with a period.

Thank You

[XRUSH] RESPONSE: ① PTO-1449 is considered

② Examiner's Amendment attached

③ Supplemental Notice of allowability needs to be mailed.

④ Interview Summary attached

INITIALS: GIV

NOTE: This form will be included as part of the official USPTO record, with the Response document coded as XRUSH.
REV 10/04

● PRINTER RUSH ●

(PTO ASSISTANCE)

Application : <u>09/792436</u>	Examiner : <u>Davis</u>	GAU : <u>2121</u>
From: <u>T. McGill</u>	Location: <u>(IDC) FMF FDC</u>	Date: <u>2-22-05</u>
Tracking #: <u>6002350</u>		Week Date: <u>1-3-05</u>

DOC CODE	DOC DATE	MISCELLANEOUS
<input type="checkbox"/> 1449		<input type="checkbox"/> Continuing Data
<input checked="" type="checkbox"/> IDS	<u>11-1-04</u>	<input type="checkbox"/> Foreign Priority
<input checked="" type="checkbox"/> CLM	<u>8-30-04</u>	<input type="checkbox"/> Document Legibility
<input type="checkbox"/> IIFW		<input type="checkbox"/> Fees
<input type="checkbox"/> SRFW		<input type="checkbox"/> Other
<input type="checkbox"/> DRW		
<input type="checkbox"/> OATH		
<input type="checkbox"/> 312		
<input type="checkbox"/> SPEC		

[RUSH] MESSAGE: ① PTO-1449 - Please initial/line through citation.

② Patent claim 17 (original claim 29) is incomplete. It does not end with a period.

Thank You

[XRUSH] RESPONSE: _____

INITIALS:

NOTE: This form will be included as part of the official USPTO record, with the Response document coded as XRUSH.
REV 10/04

94

9/8/2/5W

PTO/SB/21 (09-04)



TRANSMITTAL FORM <small>(to be used for all correspondence after initial filing)</small>	Application Number	09/792,436 ✓
	Filing Date	February 23, 2001
	First Named Inventor	Pirim, Patrick
	Art Unit	2121
	Examiner Name	George B. Davis
	Attorney Docket Number	20046H-000100US
Total Number of Pages in This Submission		

ENCLOSURES (Check all that apply)		
<input type="checkbox"/> Fee Transmittal Form <input type="checkbox"/> Fee Attached <input type="checkbox"/> Amendment/Reply <input type="checkbox"/> After Final <input type="checkbox"/> Affidavits/declaration(s) <input type="checkbox"/> Extension of Time Request <input type="checkbox"/> Express Abandonment Request <input type="checkbox"/> Information Disclosure Statement <input type="checkbox"/> Certified Copy of Priority Document(s) <input type="checkbox"/> Reply to Missing Parts/ Incomplete Application <input type="checkbox"/> Reply to Missing Parts under 37 CFR 1.52 or 1.53	<input checked="" type="checkbox"/> Replacement Drawing(s) - 31 sheets <input checked="" type="checkbox"/> Letter to Official Draftsperson <input type="checkbox"/> Petition <input type="checkbox"/> Petition to Convert to a Provisional Application <input type="checkbox"/> Power of Attorney, Revocation Change of Correspondence Address <input type="checkbox"/> Terminal Disclaimer <input type="checkbox"/> Request for Refund <input type="checkbox"/> CD, Number of CD(s) _____ <input type="checkbox"/> Landscape Table on CD	<input type="checkbox"/> After Allowance Communication to TC <input type="checkbox"/> Appeal Communication to Board of Appeals and Interferences <input type="checkbox"/> Appeal Communication to TC (Appeal Notice, Brief, Reply Brief) <input type="checkbox"/> Proprietary Information <input type="checkbox"/> Status Letter <input checked="" type="checkbox"/> Other Enclosure(s) (please identify below): Return Postcard
Remarks		The Commissioner is authorized to charge any additional fees to Deposit Account 20-1430.

SIGNATURE OF APPLICANT, ATTORNEY, OR AGENT			
Firm Name	Townsend and Townsend and Crew LLP		
Signature	<i>Gerald T. Gray</i>		
Printed name	Gerald T. Gray		
Date	January 11, 2005	Reg. No.	41,797

CERTIFICATE OF TRANSMISSION/MAILING			
I hereby certify that this correspondence is being deposited with the United States Postal Service with sufficient postage as first class mail in an envelope addressed to: Commissioner for Patents, P.O. Box 1450, Alexandria, VA 22313-1450 on the date shown below.			
Signature	<i>Sylvia E. Arnold</i>		
Typed or printed name	Sylvia E. Arnold	Date	January 11, 2005

I hereby certify that this correspondence is being deposited with the United States Postal Service as first class mail in an envelope addressed to:

PATENT
Attorney Docket No.: 20046H-000100US

Mail Stop Issue Fee
Commissioner for Patents,
P.O. Box 1450
Alexandria, VA 22313-1450, on January 11, 2005



TOWNSEND and TOWNSEND and CREW LLP

By Sylvia E. Arnold
Sylvia E. Arnold

IN THE UNITED STATES PATENT AND TRADEMARK OFFICE

In re application of:

Patrick Pirim

Examiner: George B. Davis

Application No.: 09/792,436

Art Unit: 2121

Filed: February 23, 2001

LETTER TO OFFICIAL DRAFTSPERSON

For: METHOD AND DEVICE FOR
AUTOMATIC VISUAL PERCEPTION

Mail Stop Issue Fee
Commissioner for Patents
P.O. Box 1450
Alexandria, VA 22313-1450

Sir:

Pursuant to the Supplemental Notice of Allowability dated December 30, 2004, applicant submits 31 sheets of formal, replacement drawings to be made of record in the above-identified case. These drawings include the changes required by the Examiner in the Office Action dated March 26, 2004.

Respectfully submitted,

Gerald T. Gray
Gerald T. Gray
Reg. No. 41,797

TOWNSEND and TOWNSEND and CREW LLP
Two Embarcadero Center, Eighth Floor
San Francisco, California 94111-3834
(415) 576-0200 Fax (415) 576-0300
GTG/sea
60396248 v1

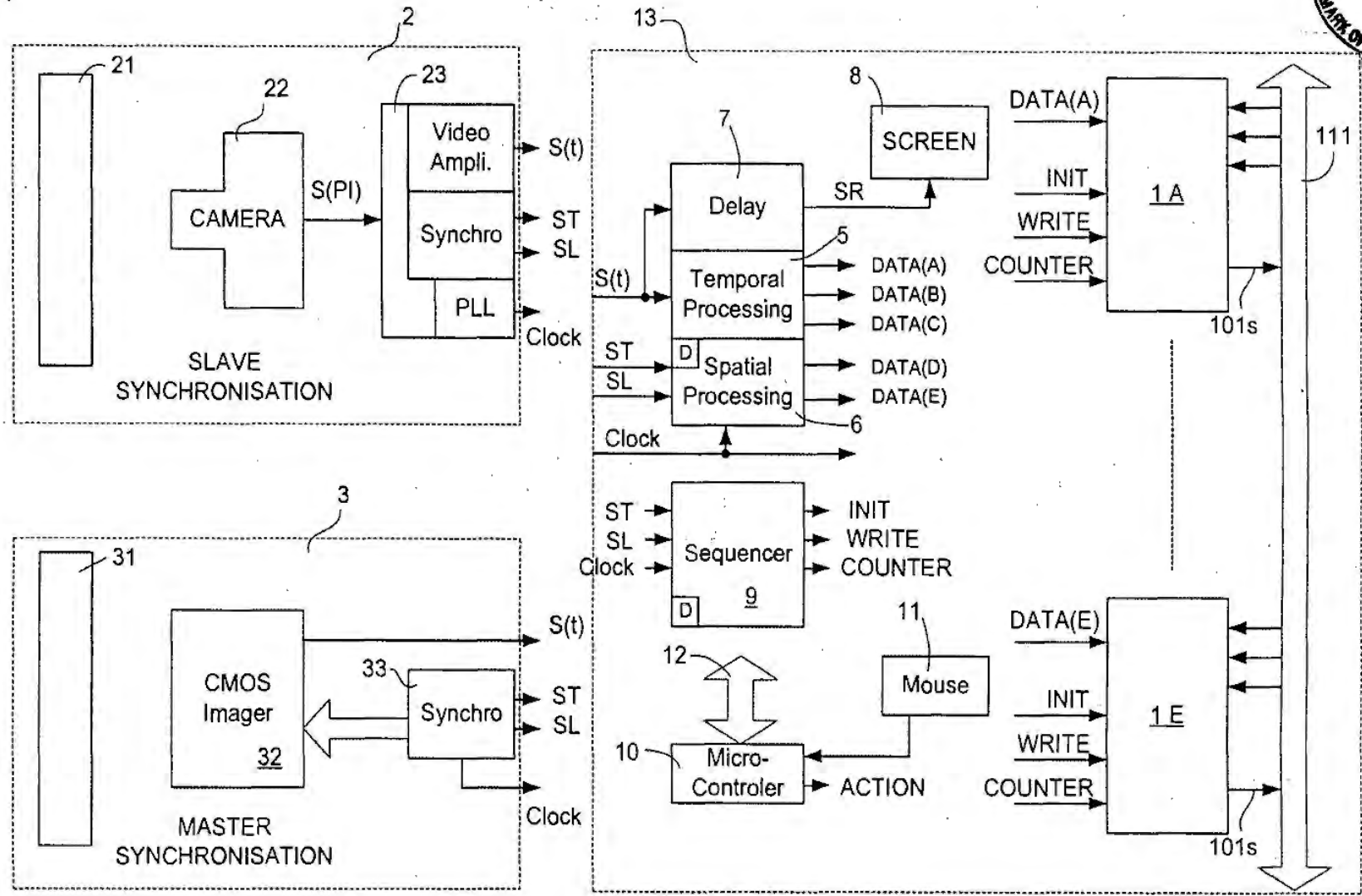

FIG. 1 PRIOR ART

Application No.: 09/792,436
 Applicant: Patrick Plim
 Title: METHOD AND DEVICE FOR AUTOMATIC VISUAL PERCEPTION
 REPLACEMENT SHEET 1 of 31



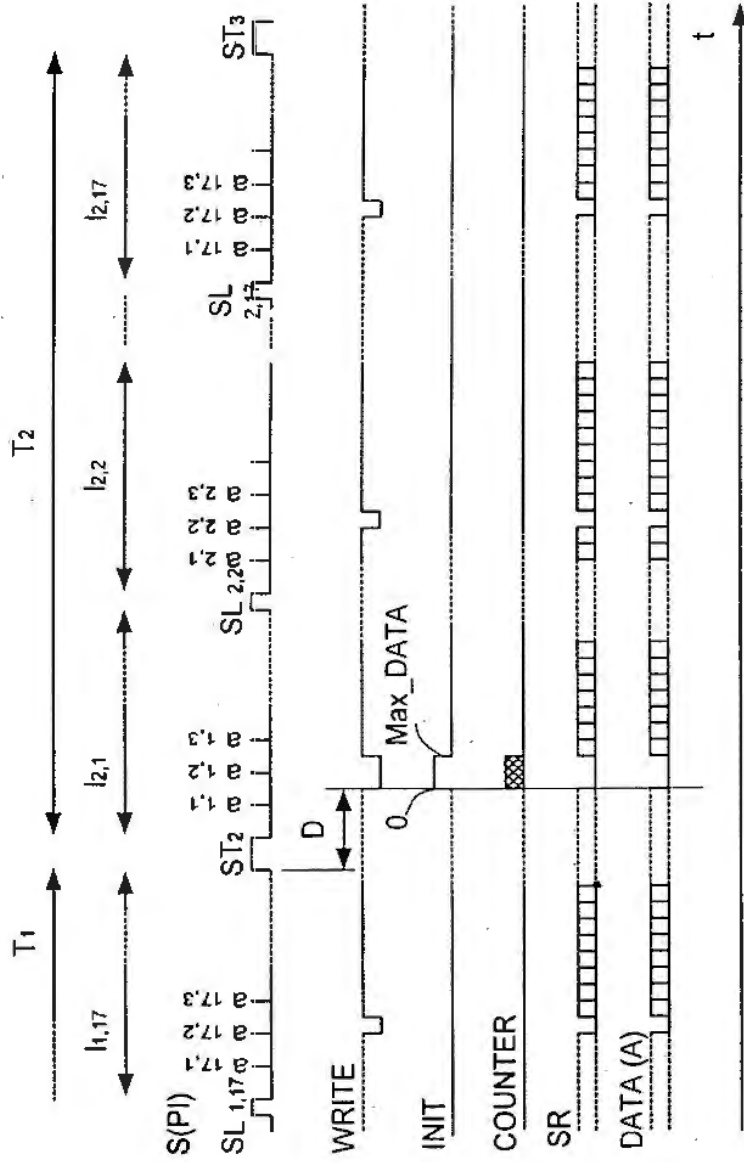

FIG. 2

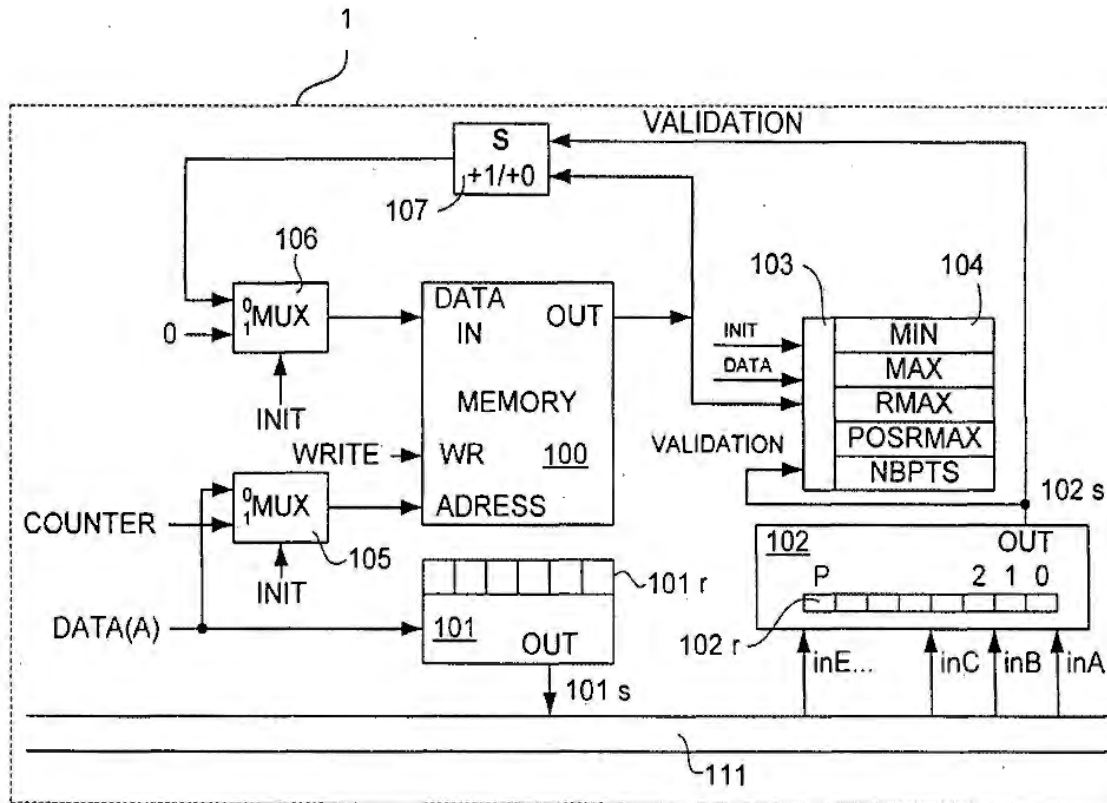

FIG. 3

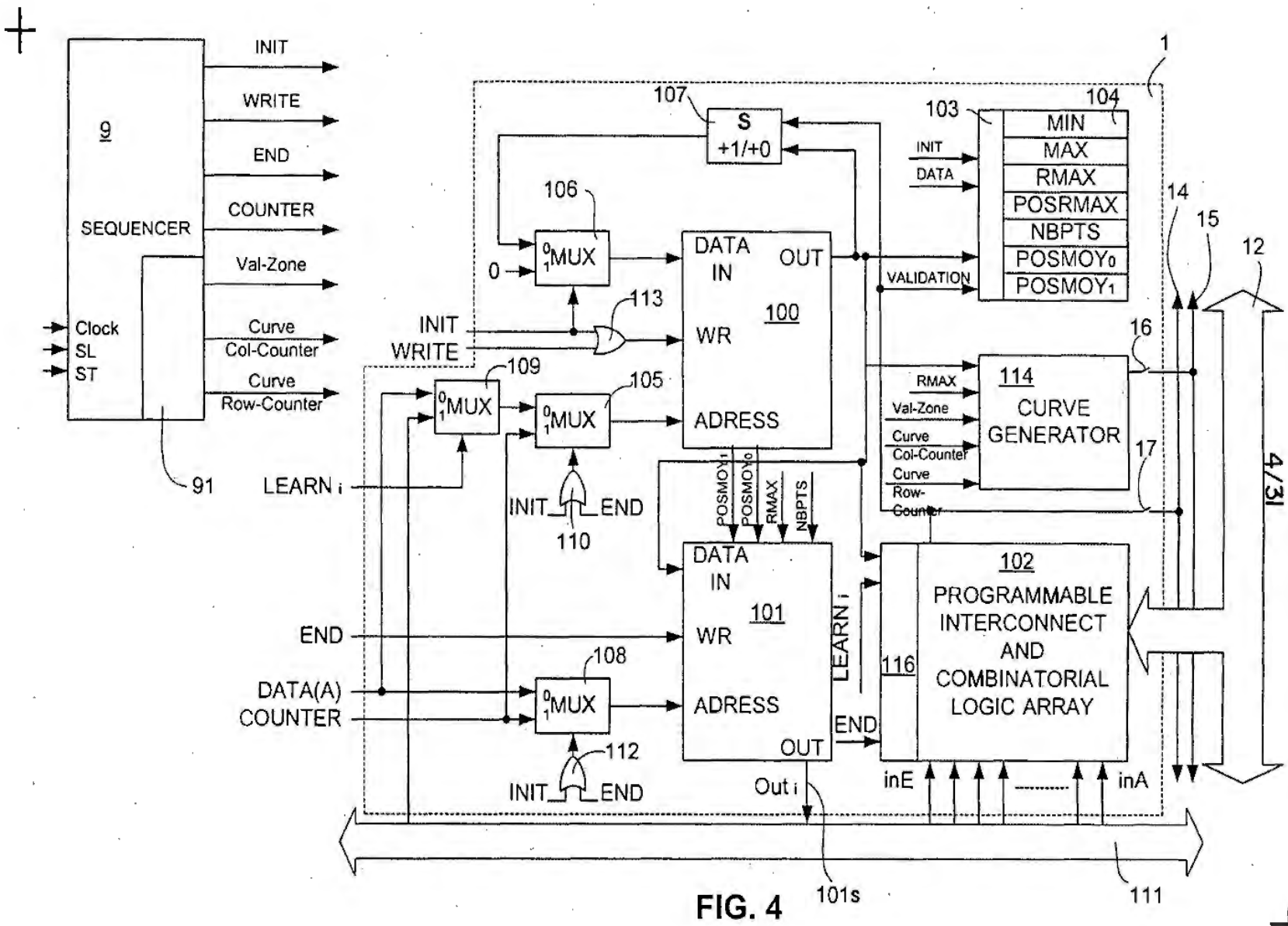

FIG. 4

Application No.: 09/792,438
 Applicant: Patrick Pflim
 Title: METHOD AND DEVICE FOR AUTOMATIC VISUAL PERCEPTION
 REPLACEMENT SHEET 4 of 31

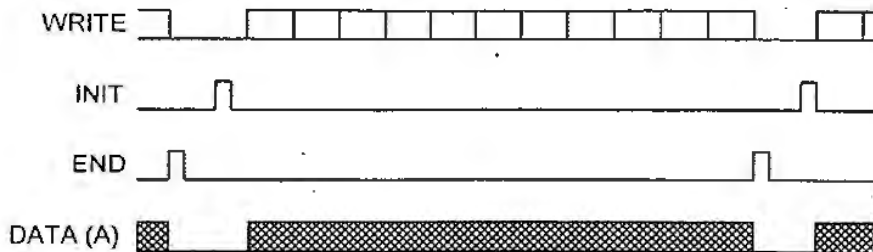

FIG. 5

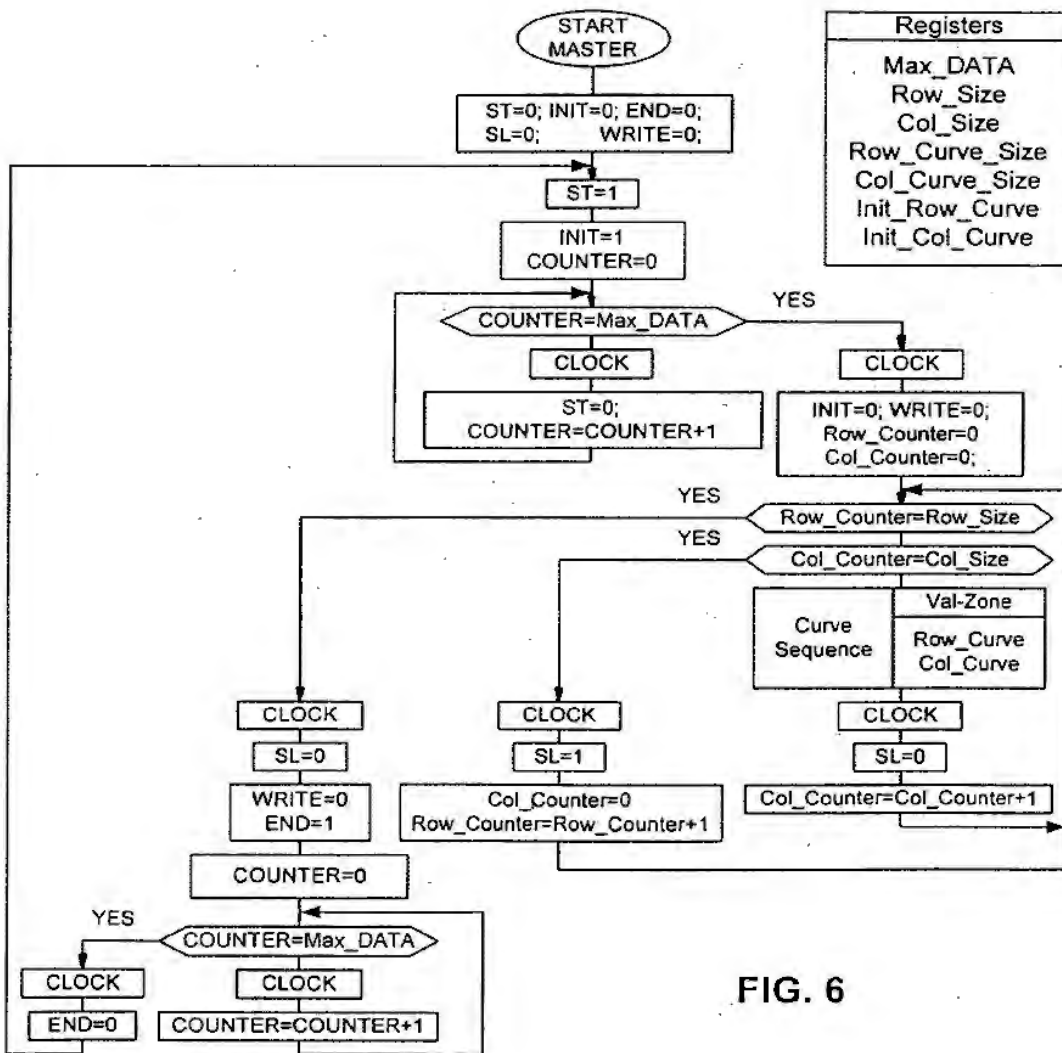
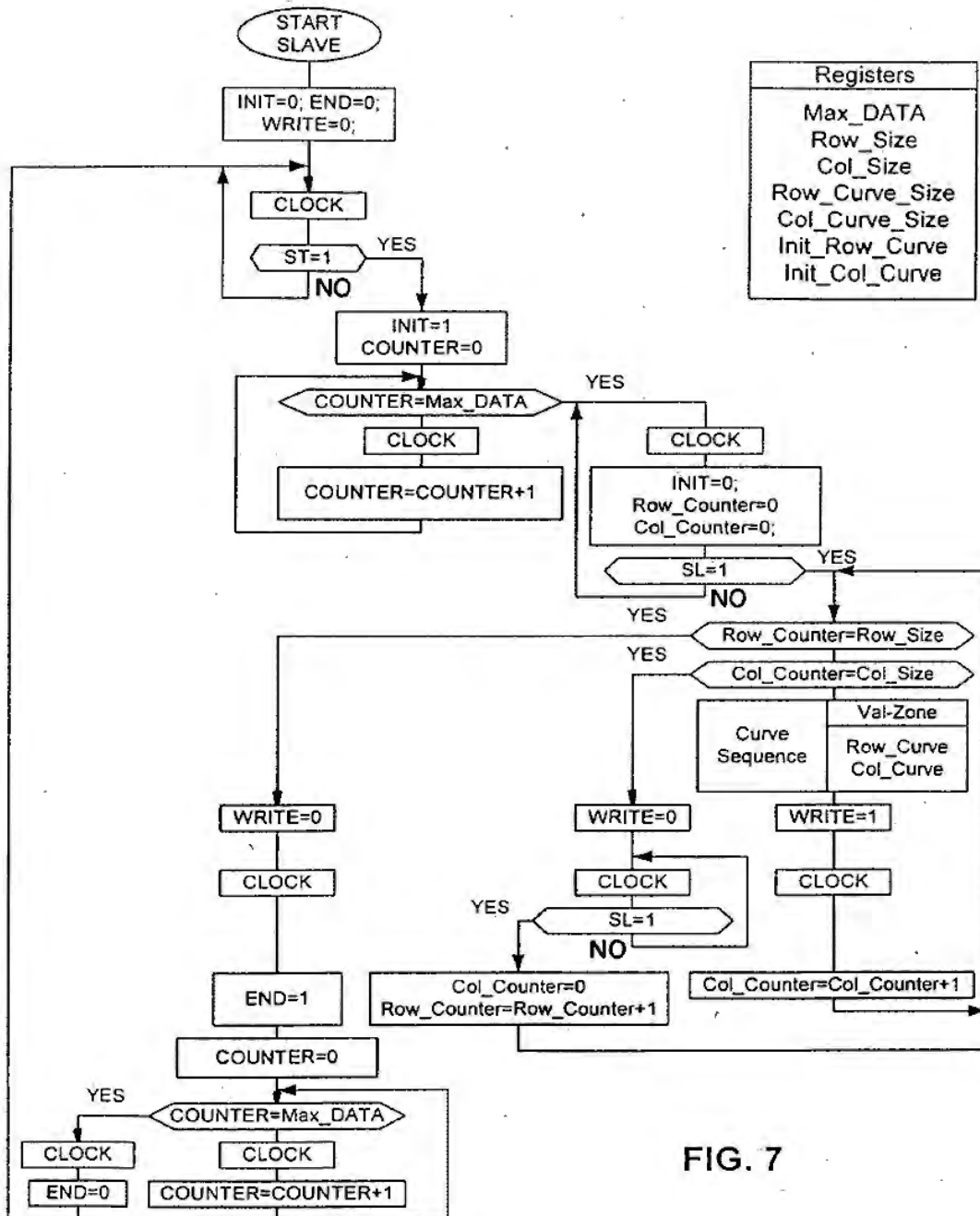

FIG. 6



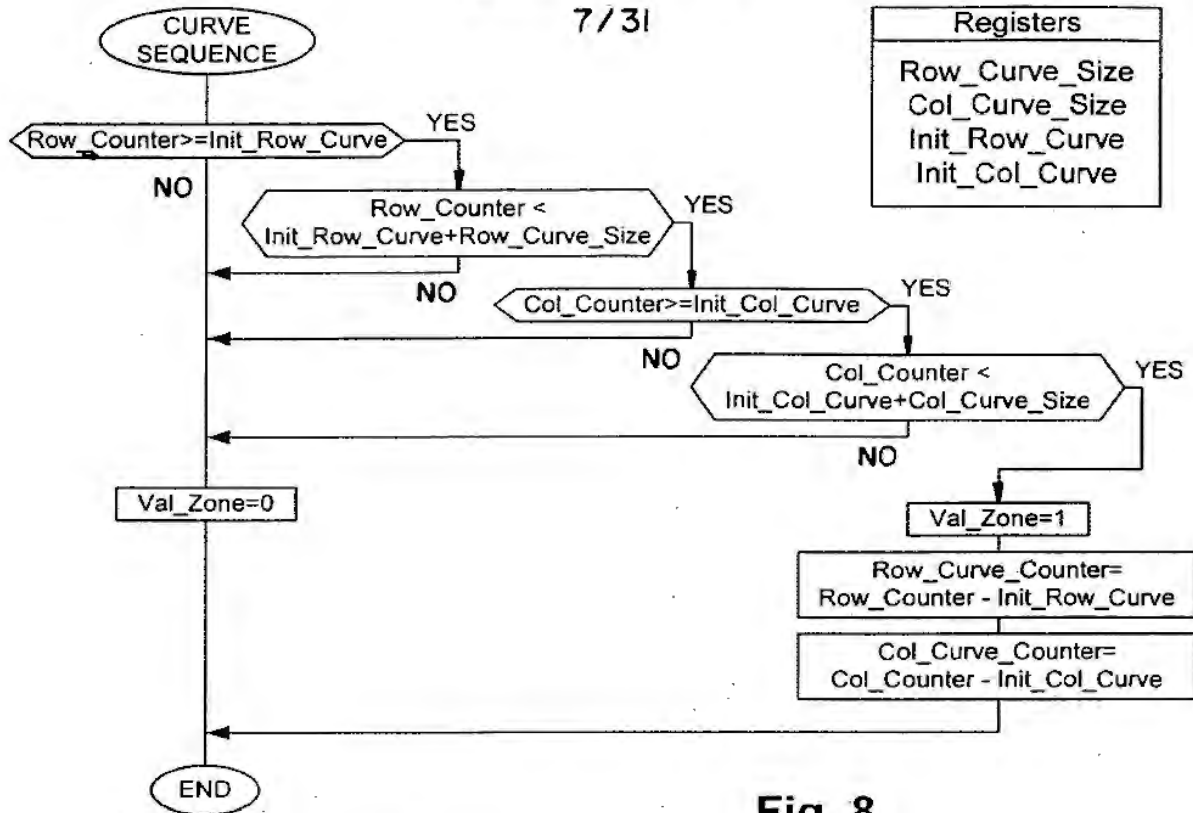

Fig. 8

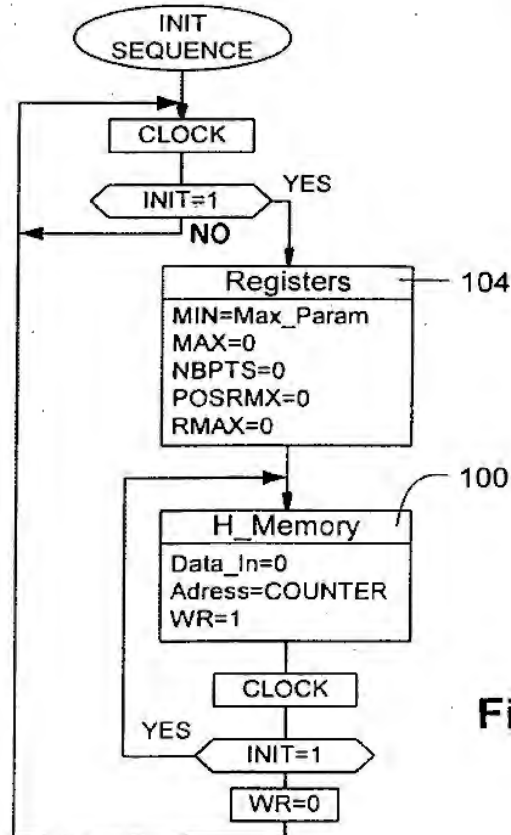

Fig. 9

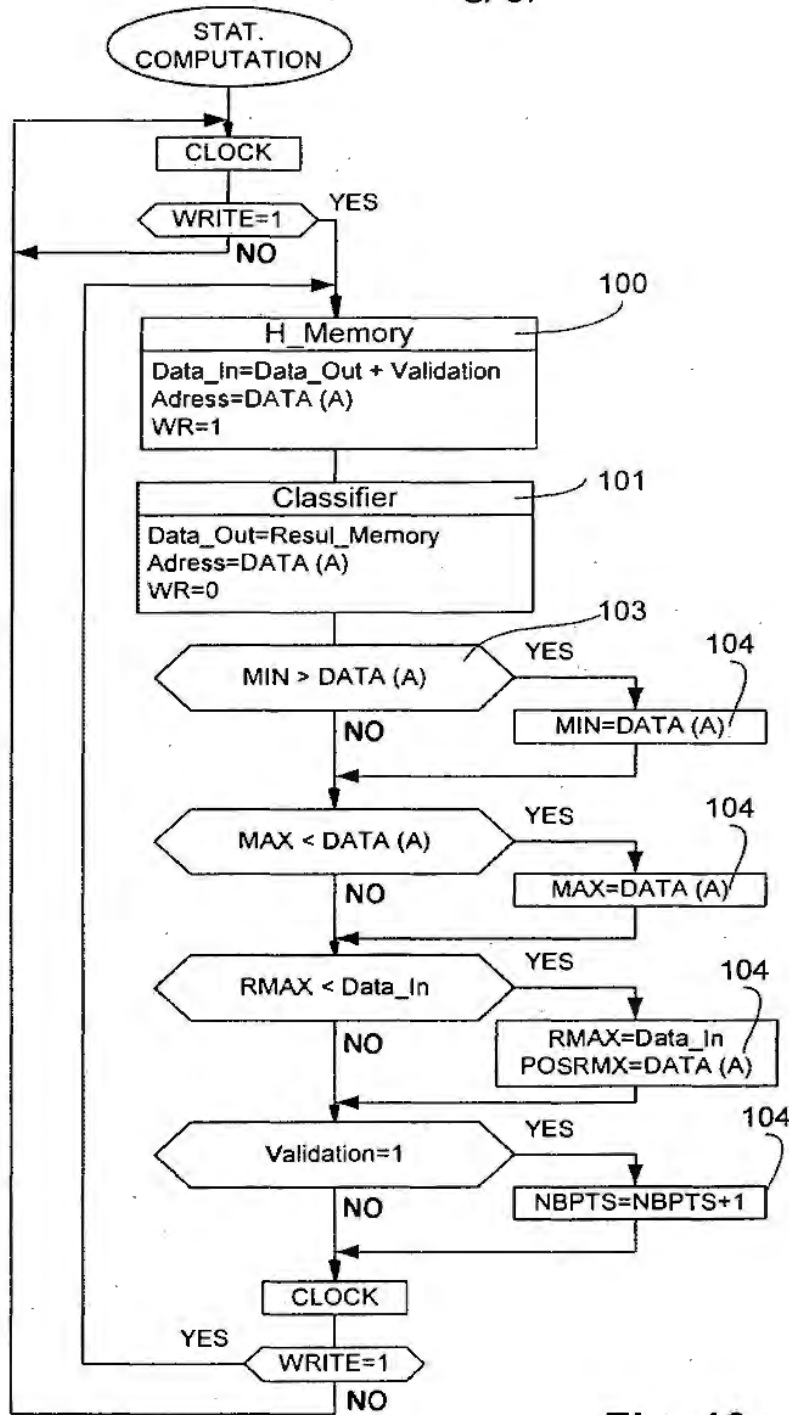

Fig. 10

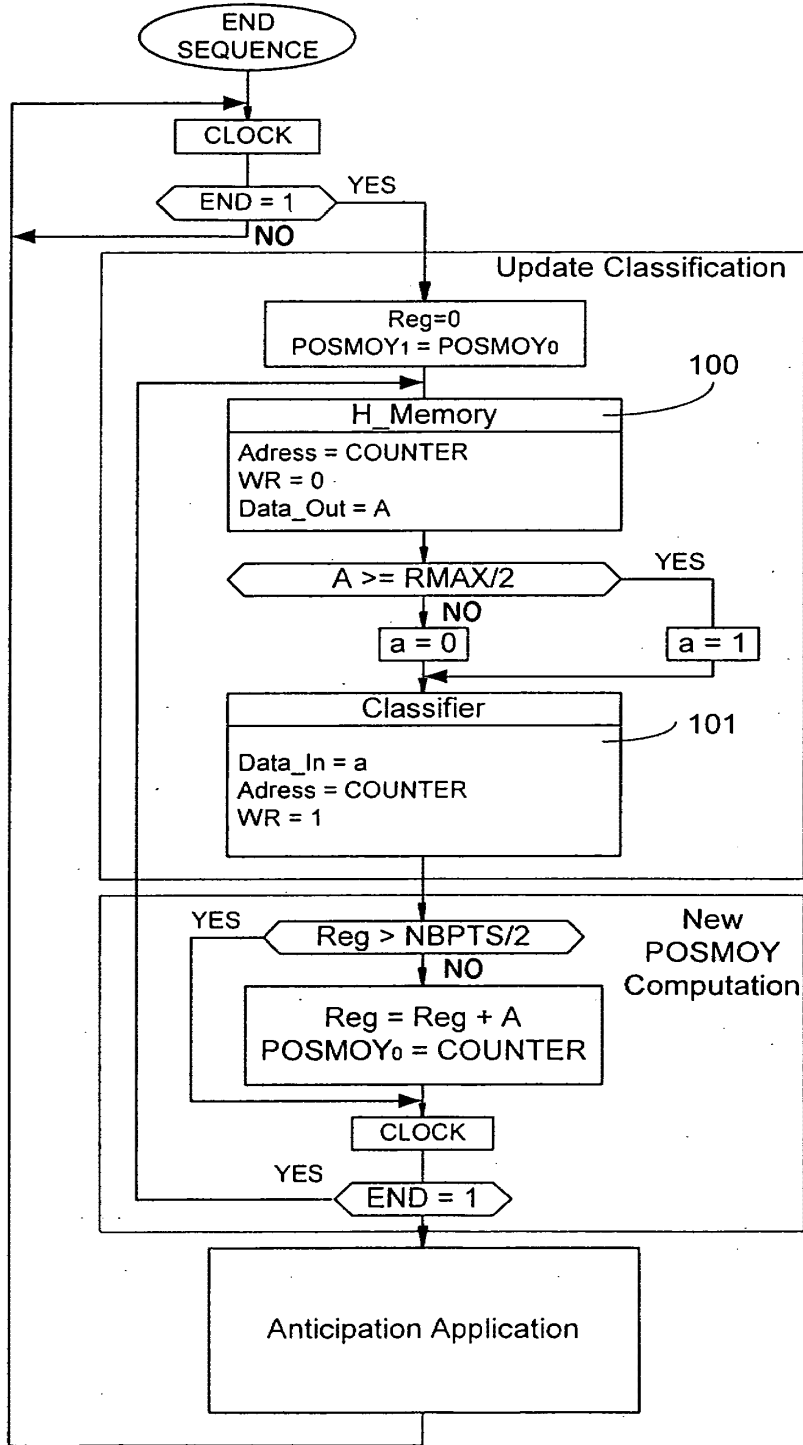

Fig. 11

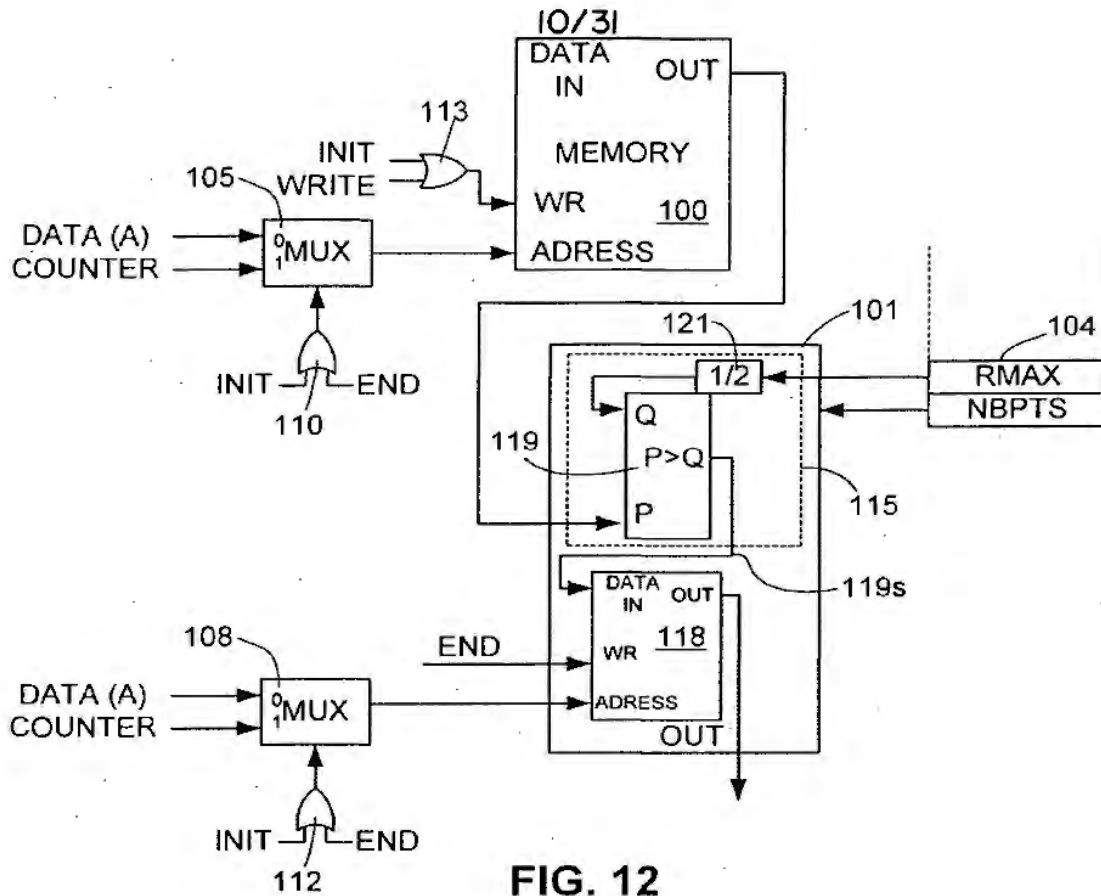

FIG. 12

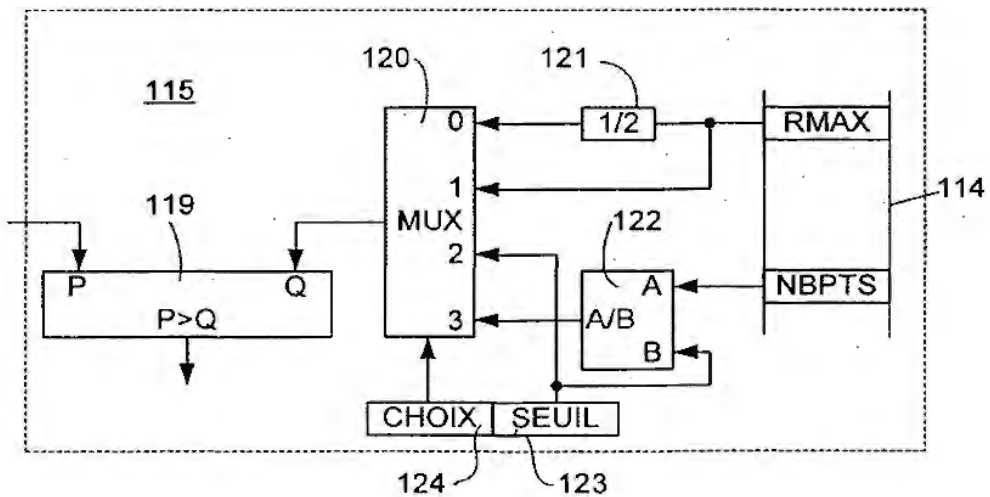

FIG. 13a

11/31

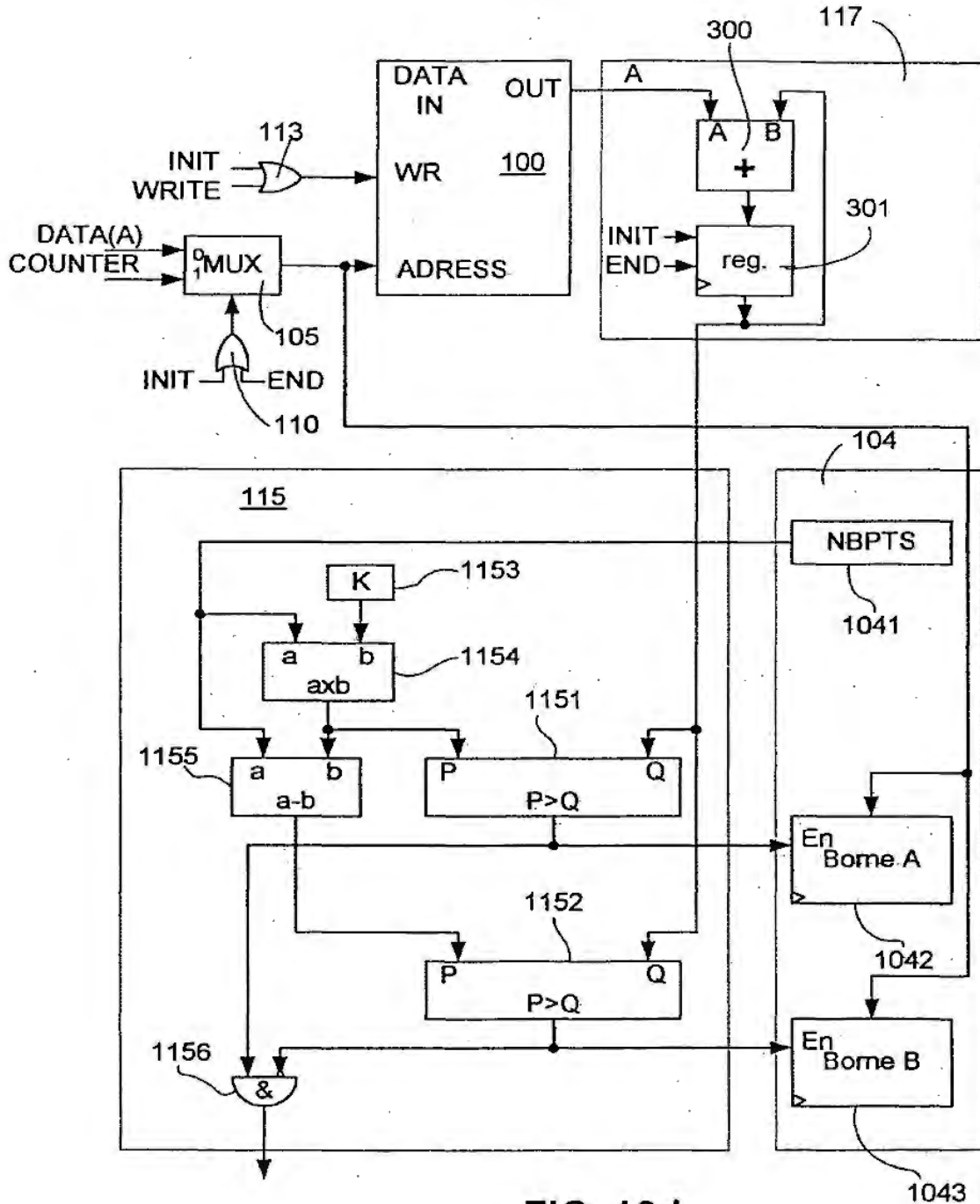
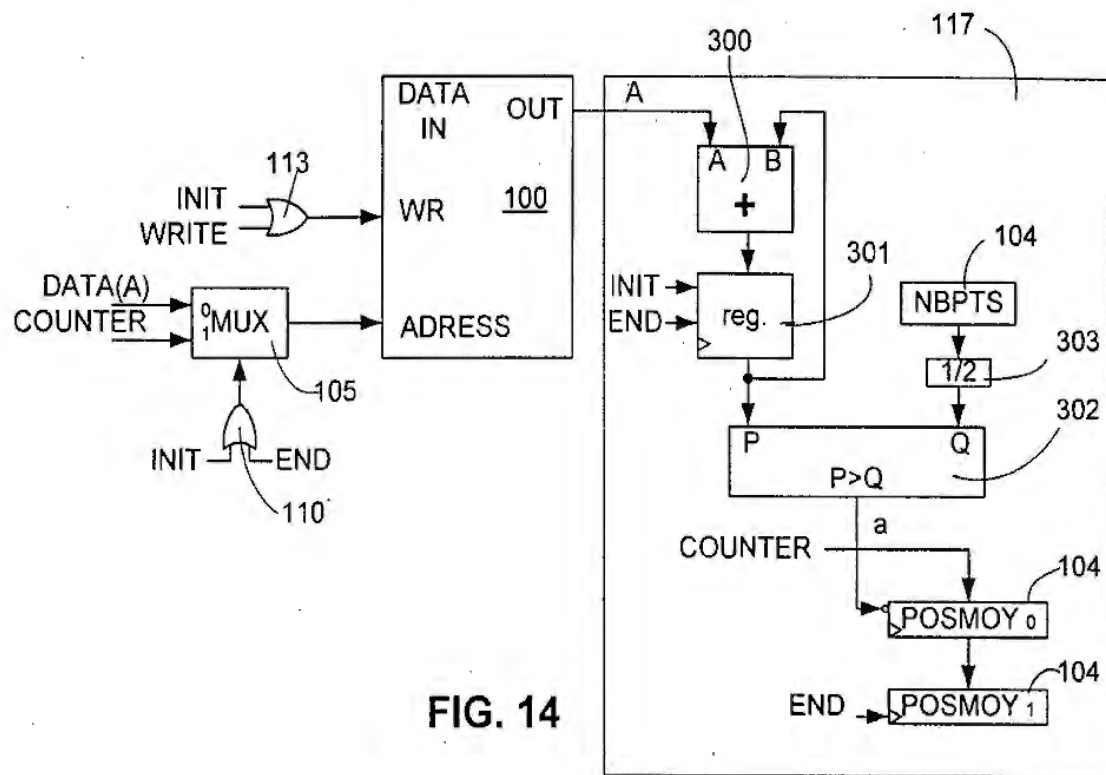

FIG. 13d

+



+

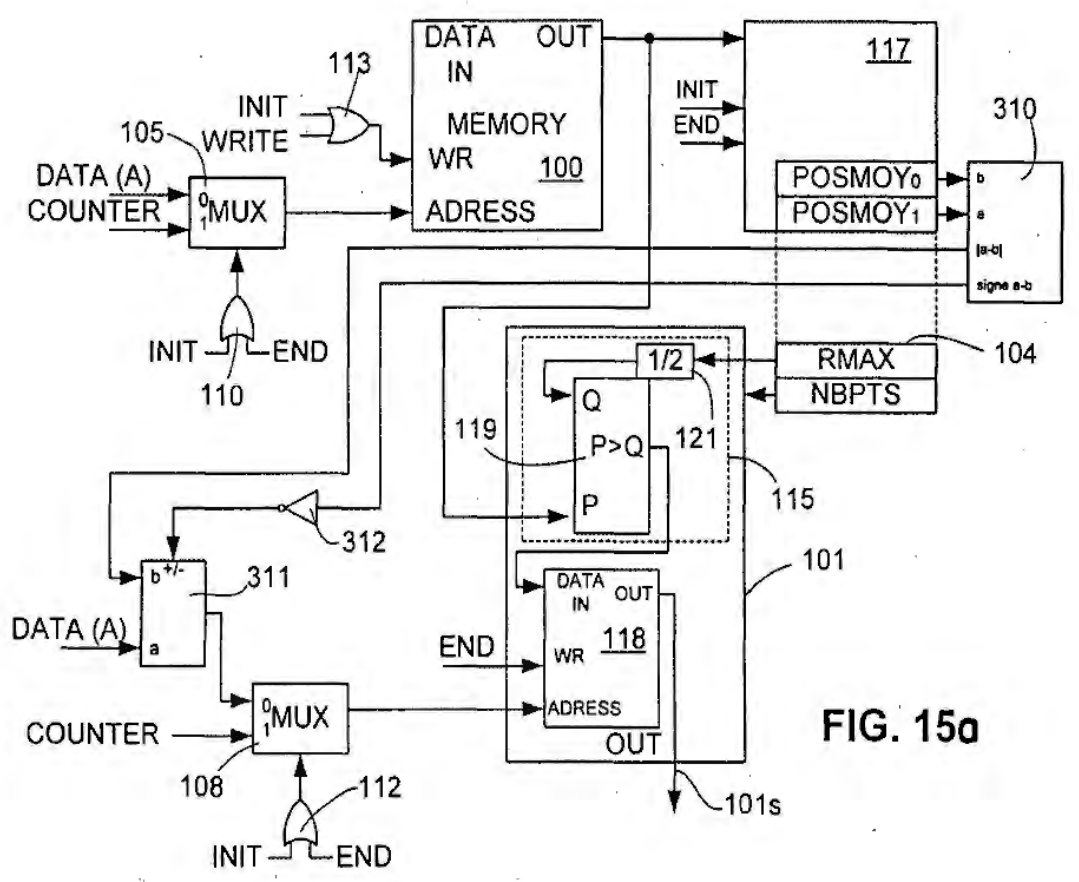

FIG. 15a

13/31

Application No.: 09/792,436
 Applicant: Patrick Pirim
 Title: METHOD AND DEVICE FOR AUTOMATIC VISUAL PERCEPTION
 REPLACEMENT SHEET 13 of 31

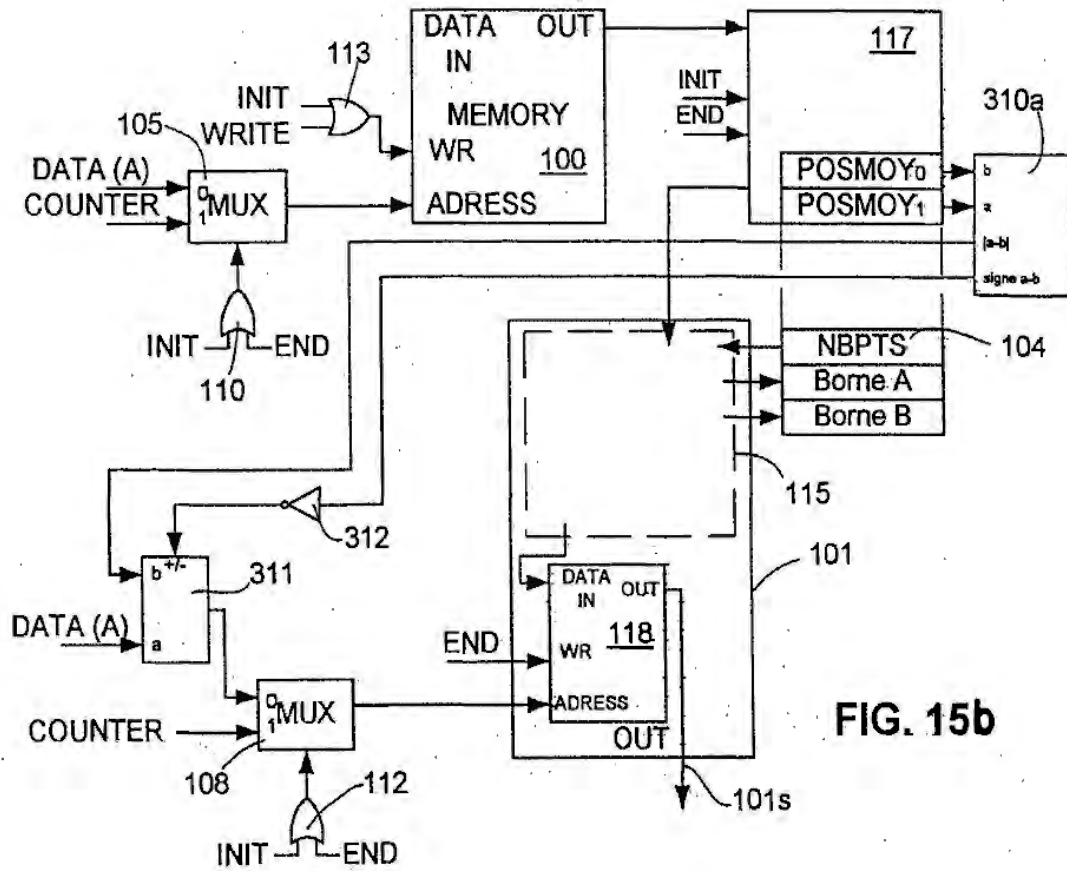

FIG. 15b

14/31

Application No.: 09/792,436
 Applicant: Patrick Pflim
 Title: METHOD AND DEVICE FOR AUTOMATIC VISUAL PERCEPTION
 REPLACEMENT SHEET 14 of 31

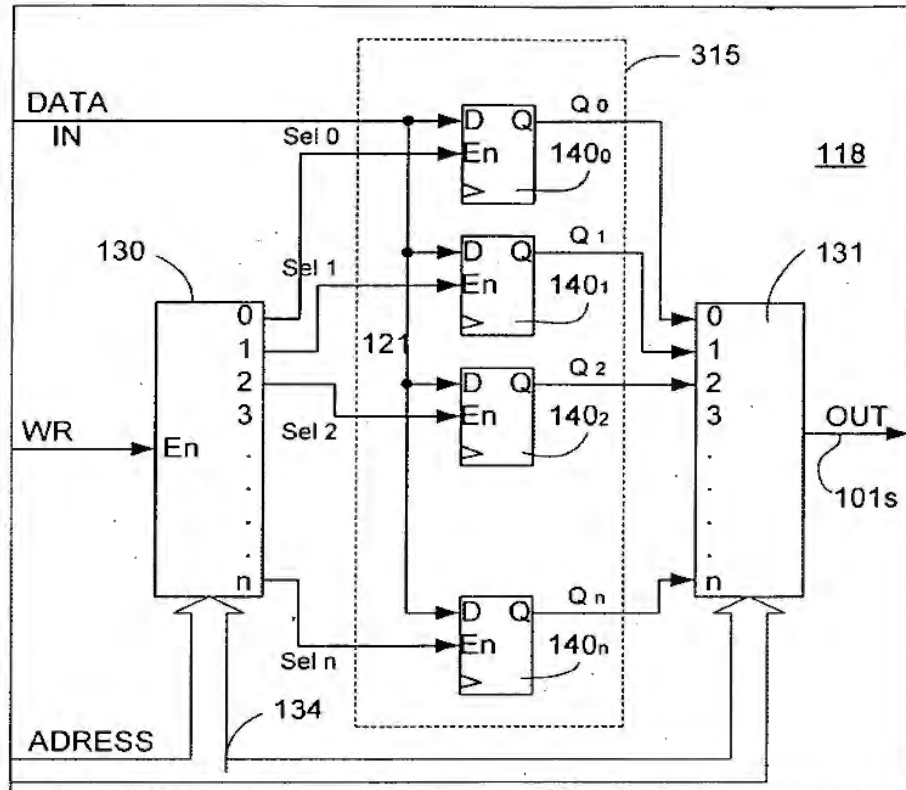
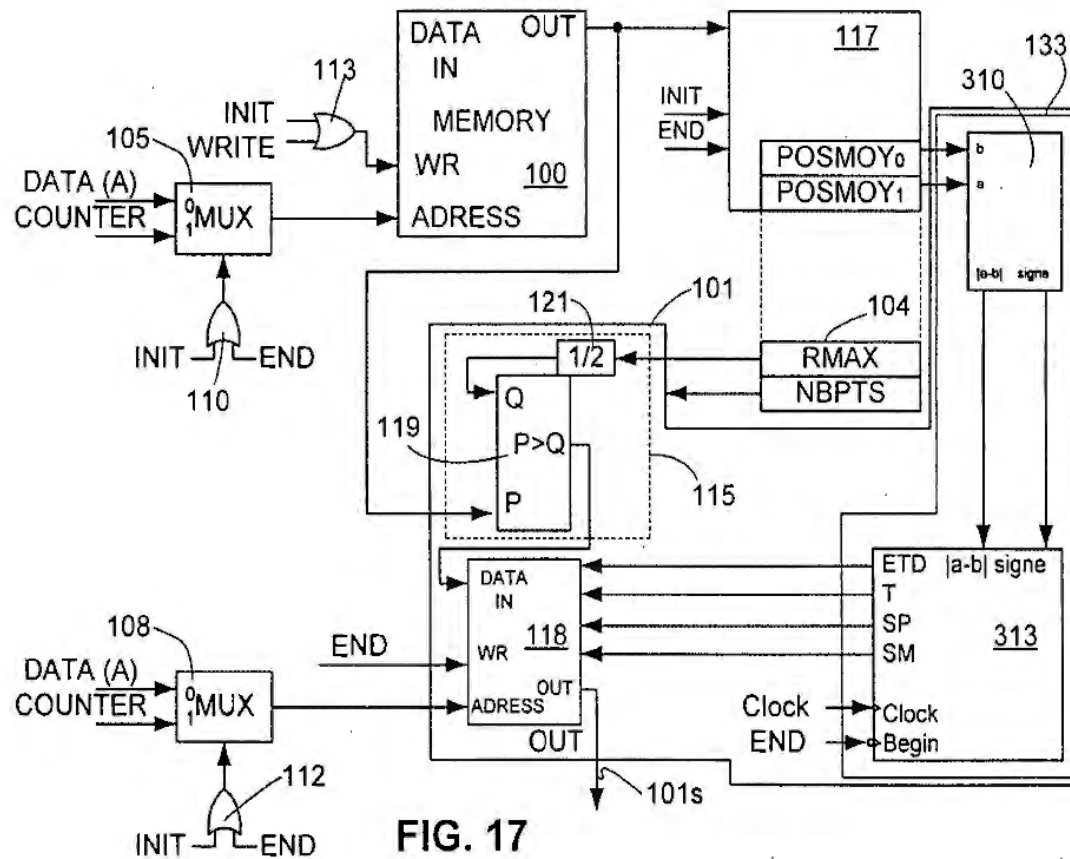

FIG. 16



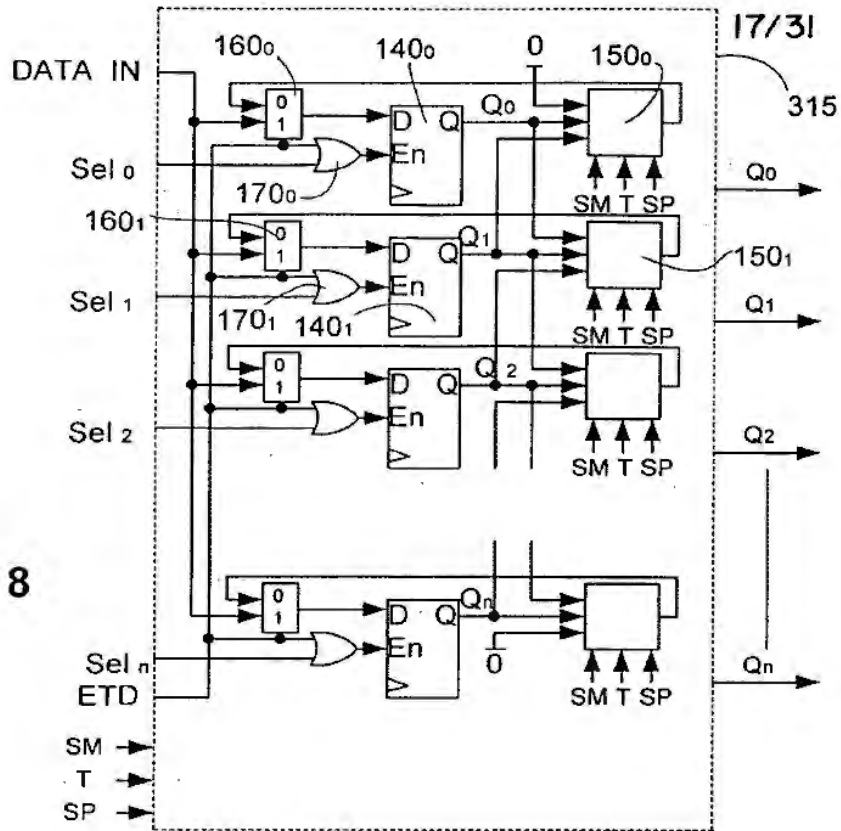

FIG. 18

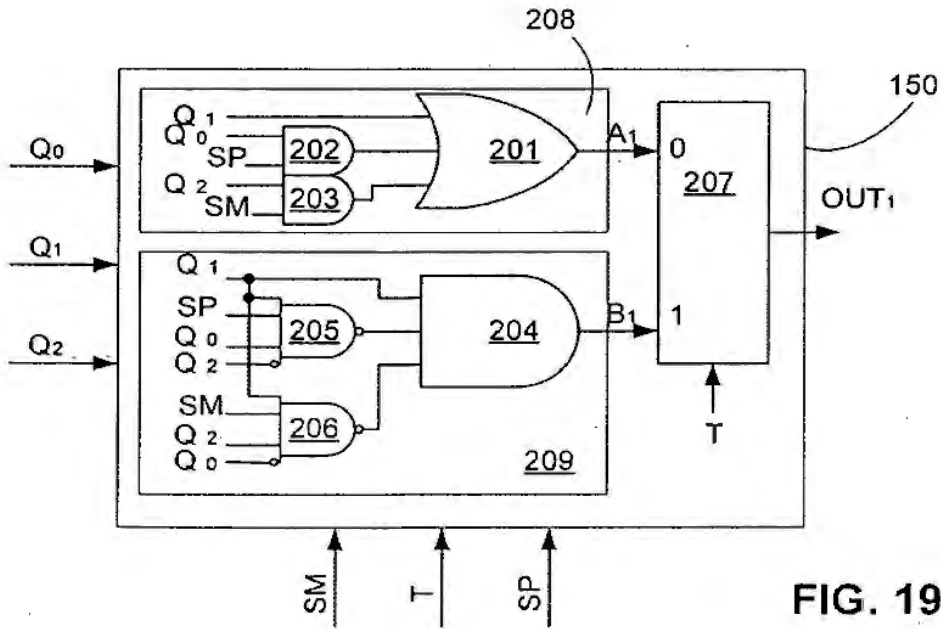

FIG. 19

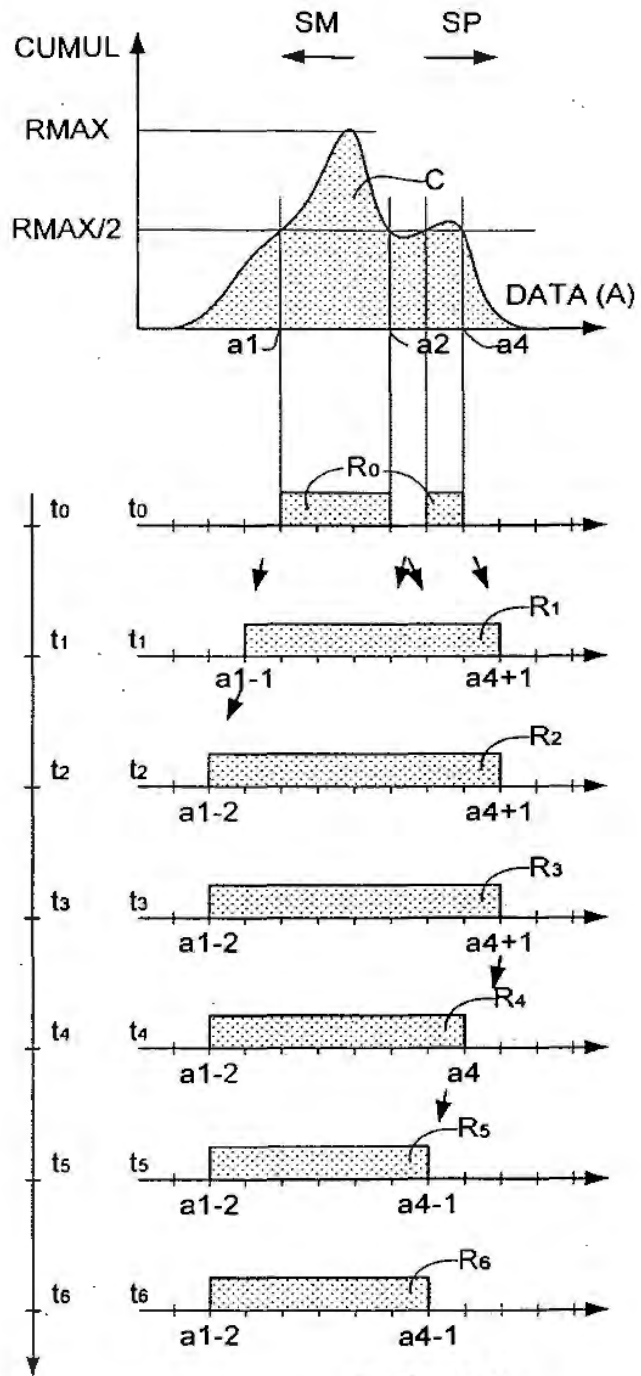
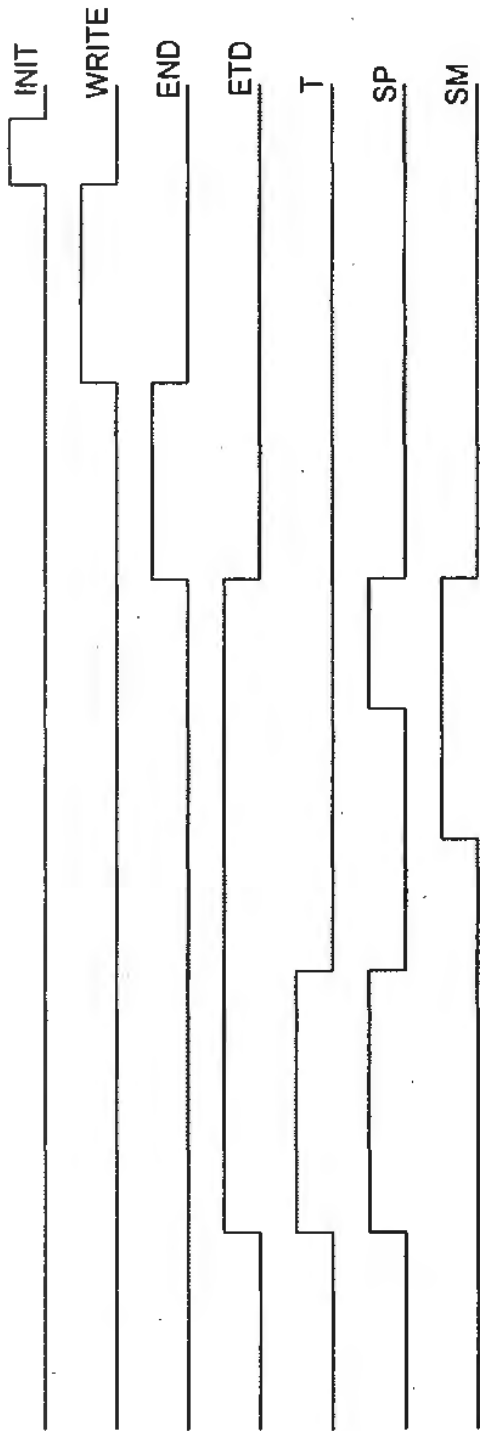

FIG. 20

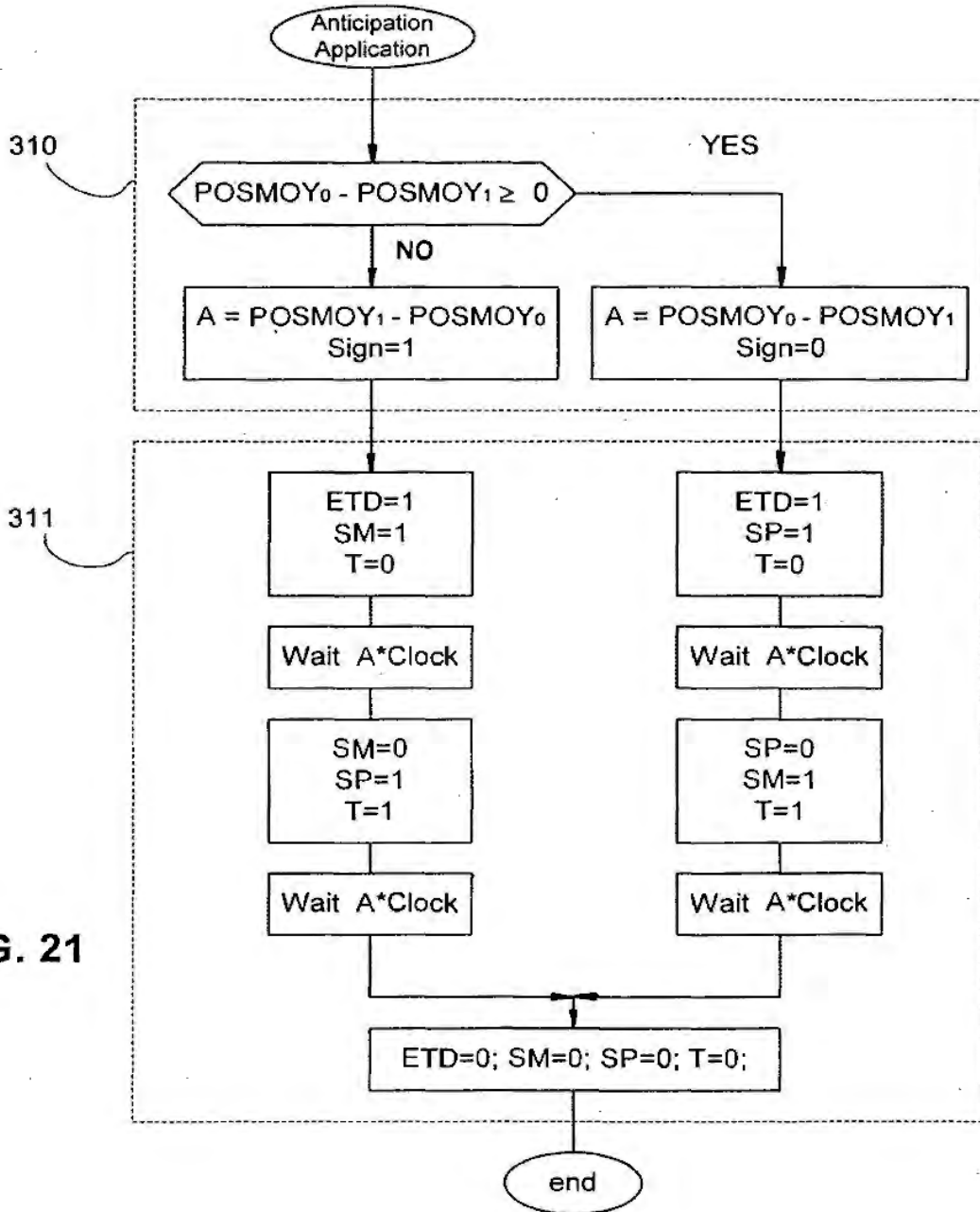

FIG. 21

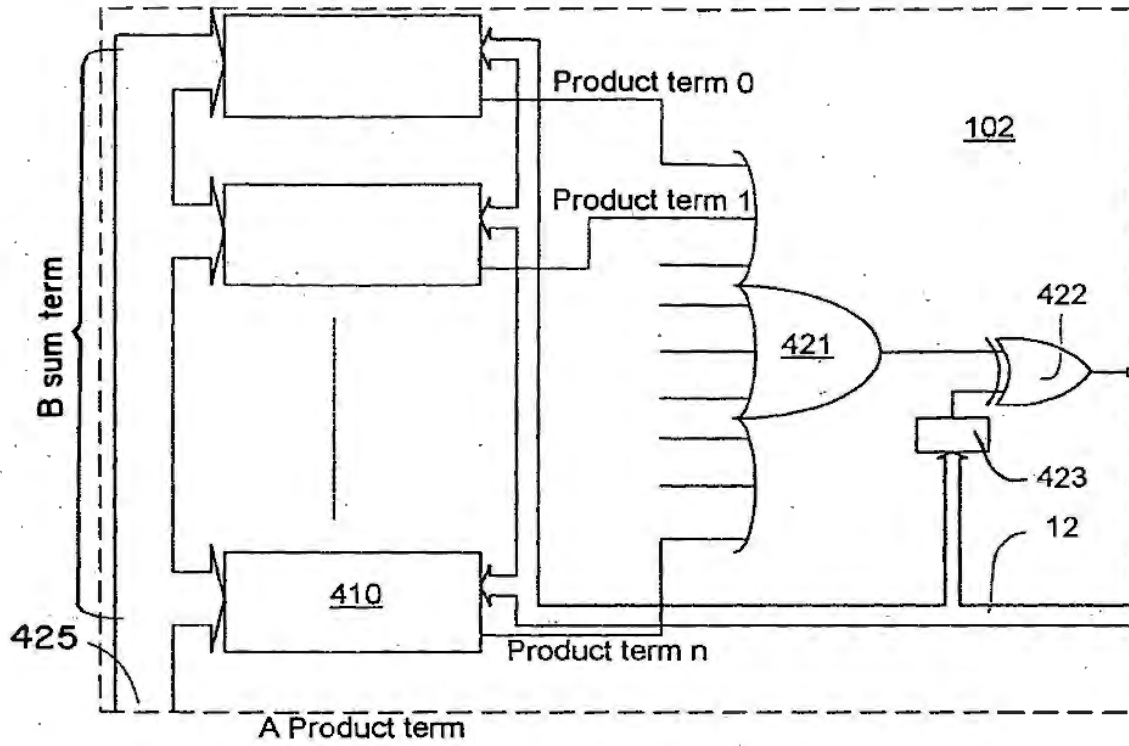

FIG 22

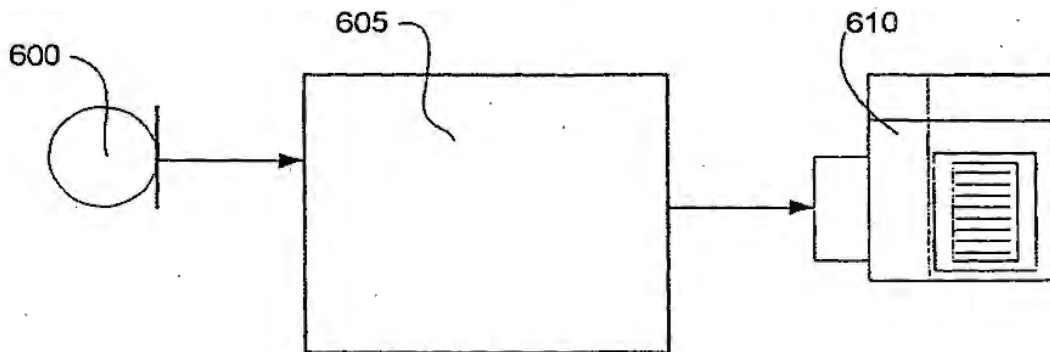

FIG. 39

21/31

400

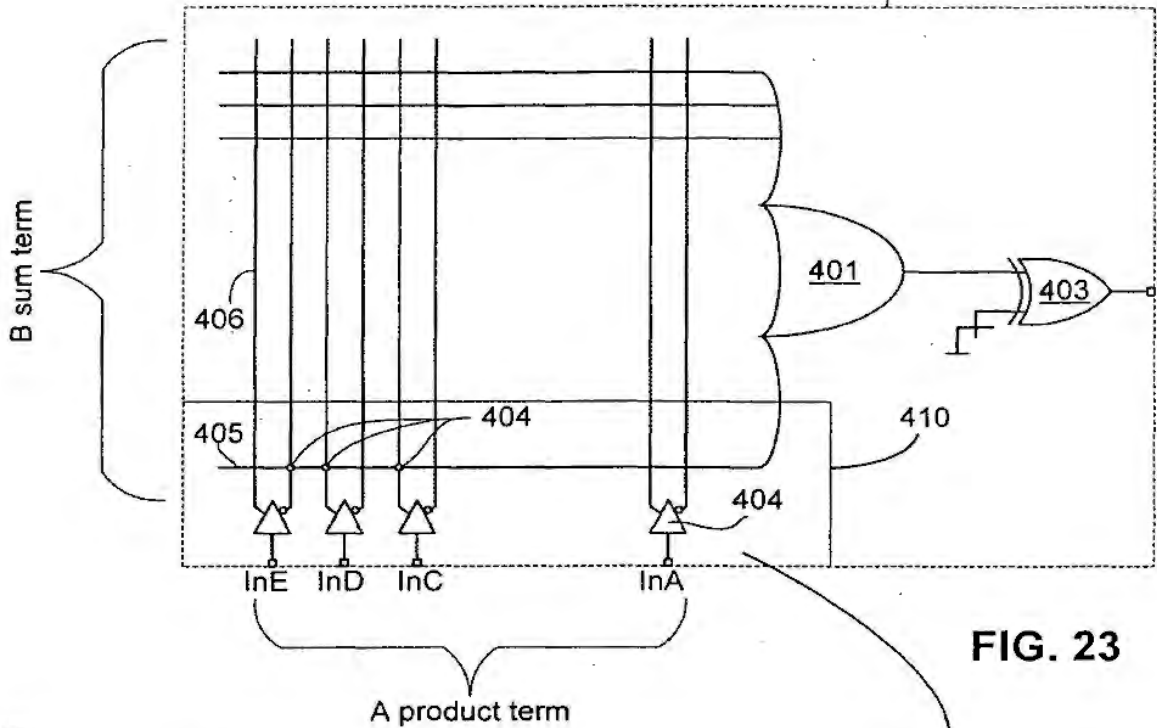

FIG. 23

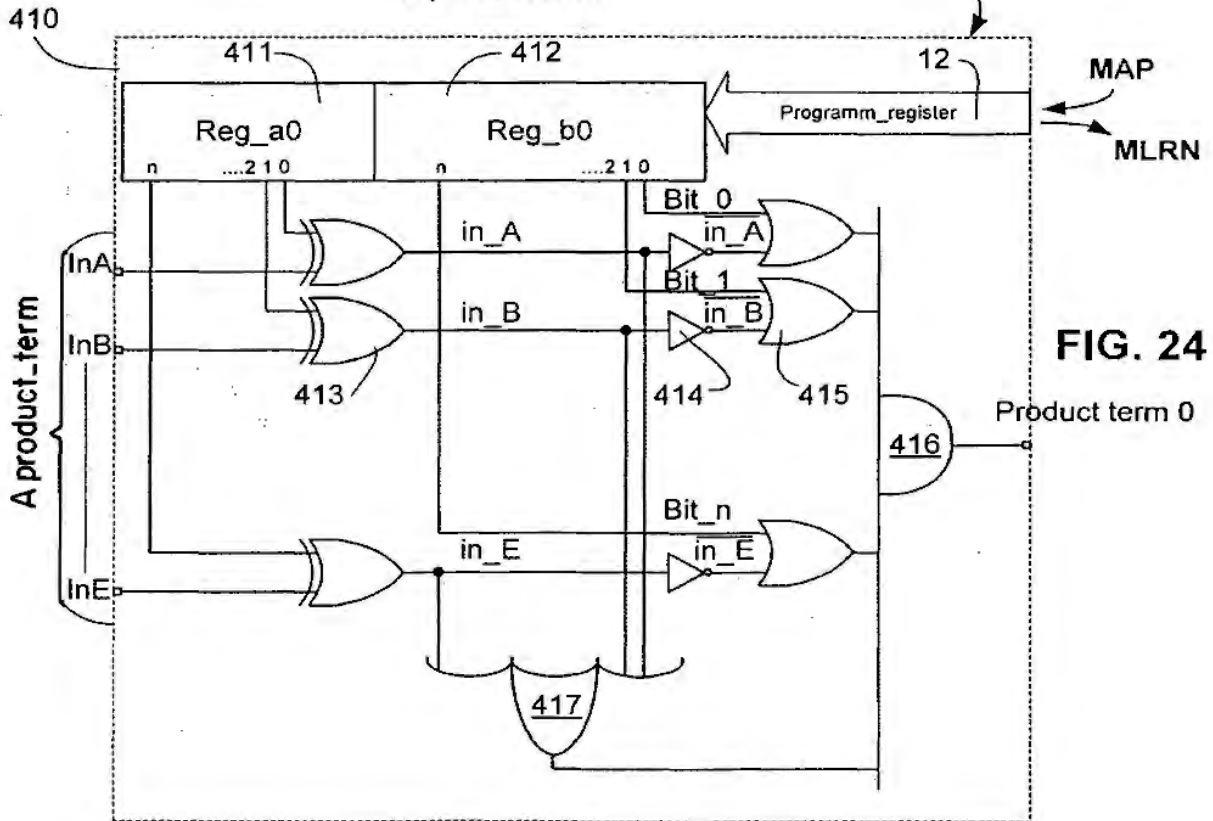

FIG. 24

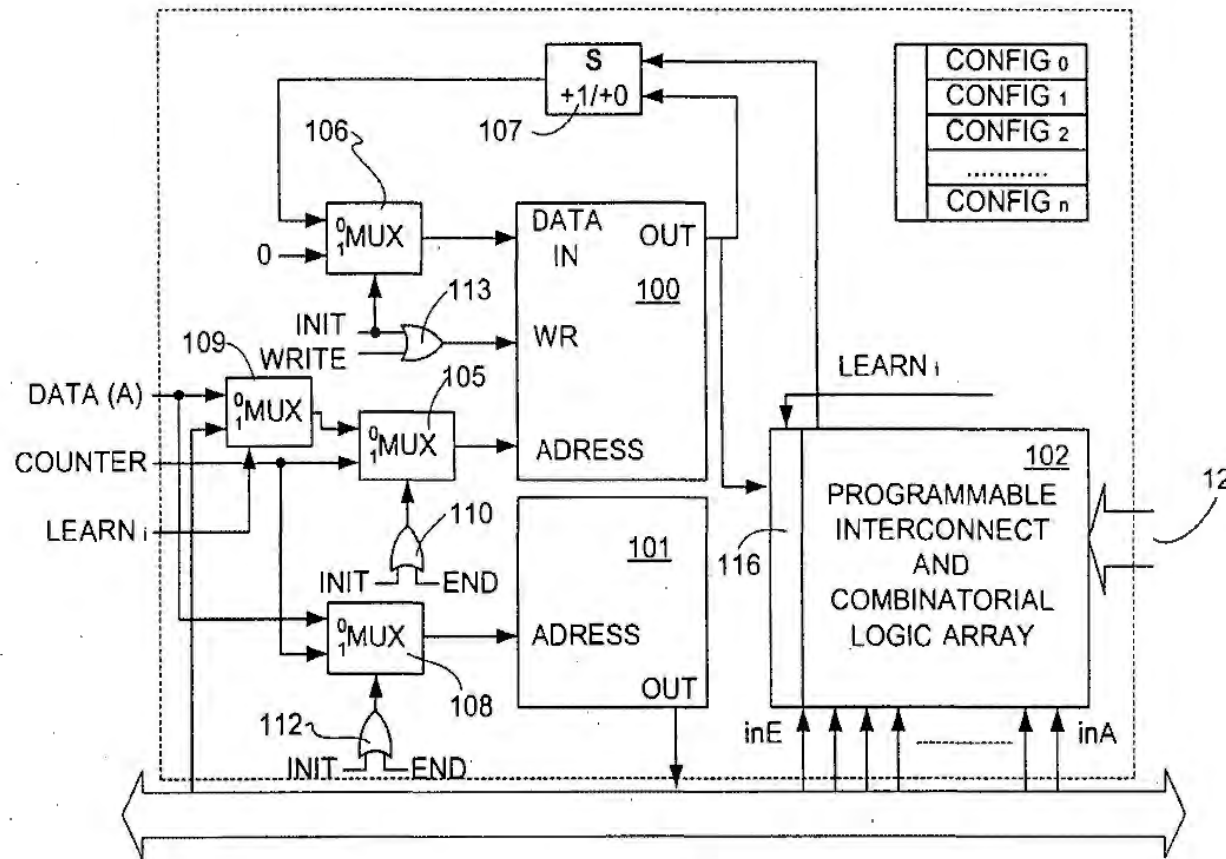

FIG. 25

23/31

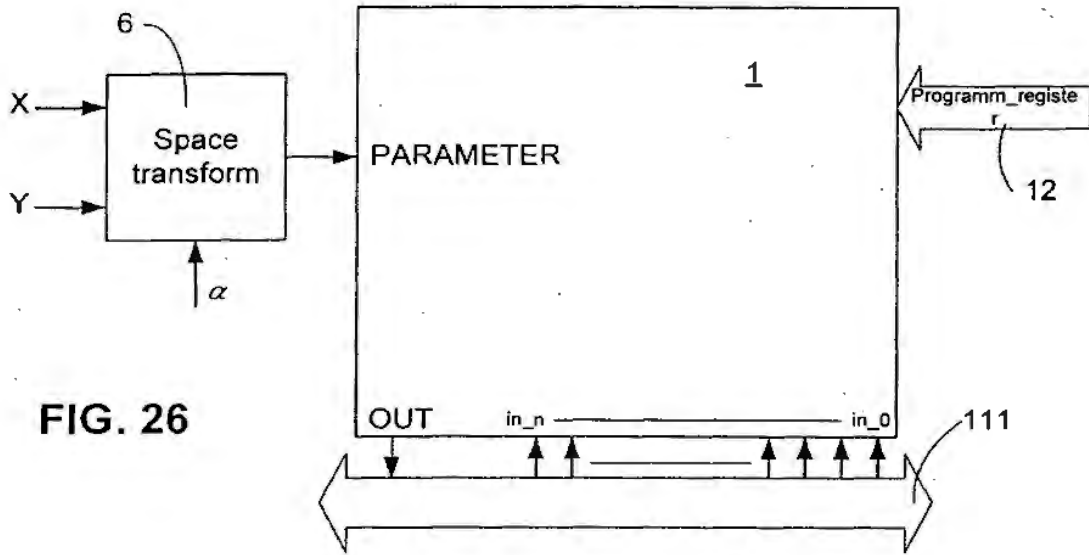

FIG. 26

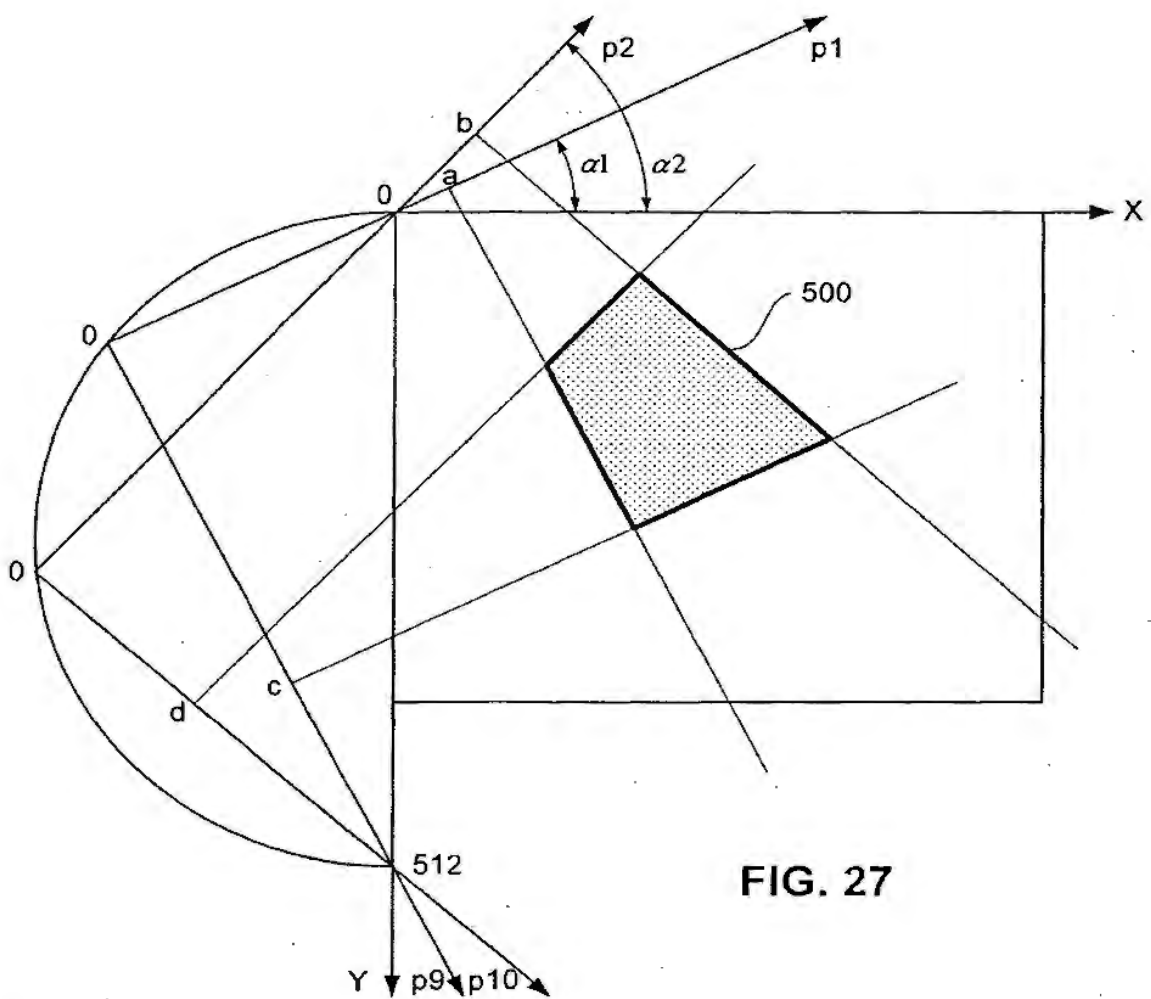

FIG. 27

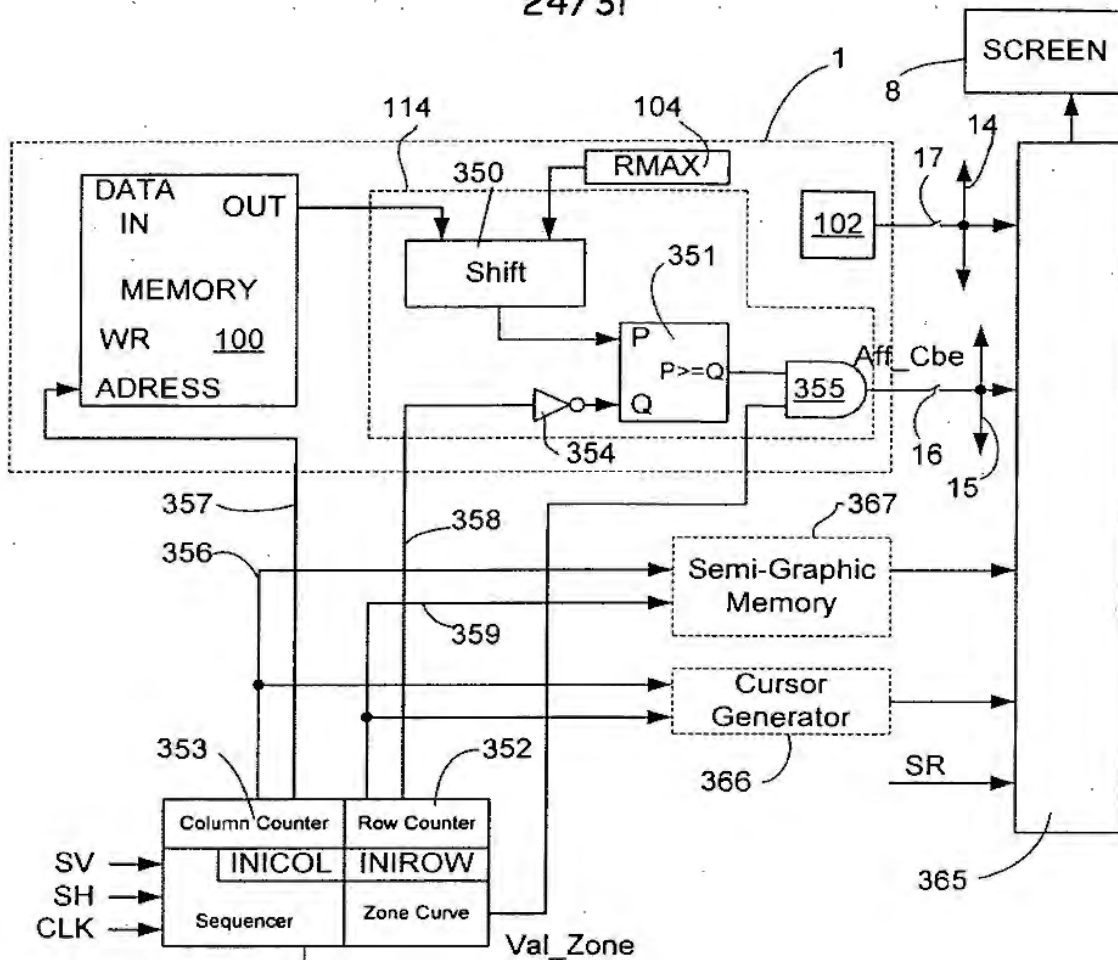

Fig. 28

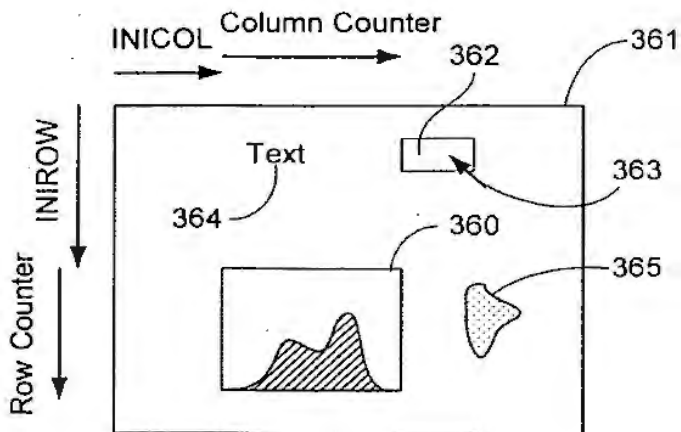

Fig. 29

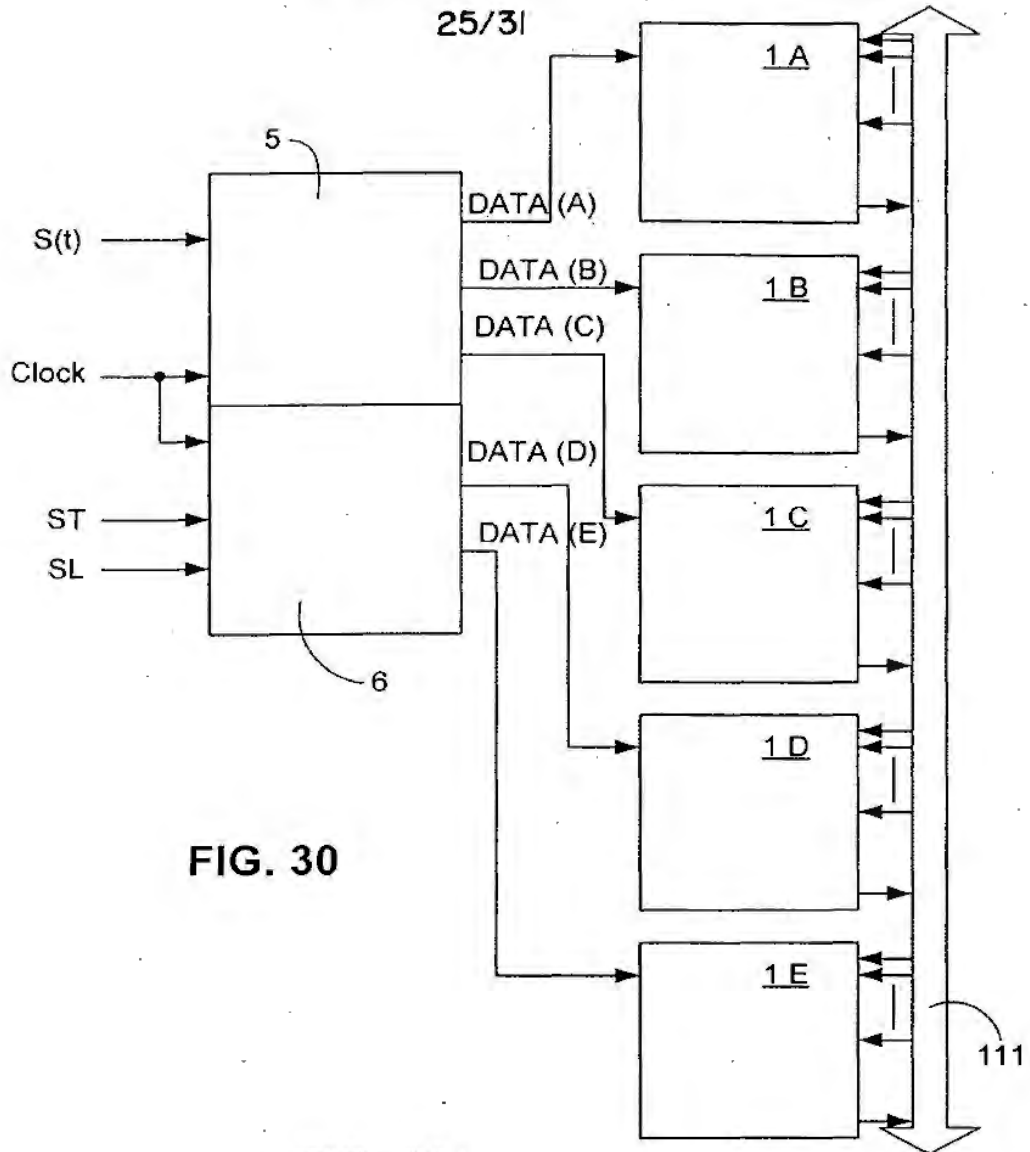
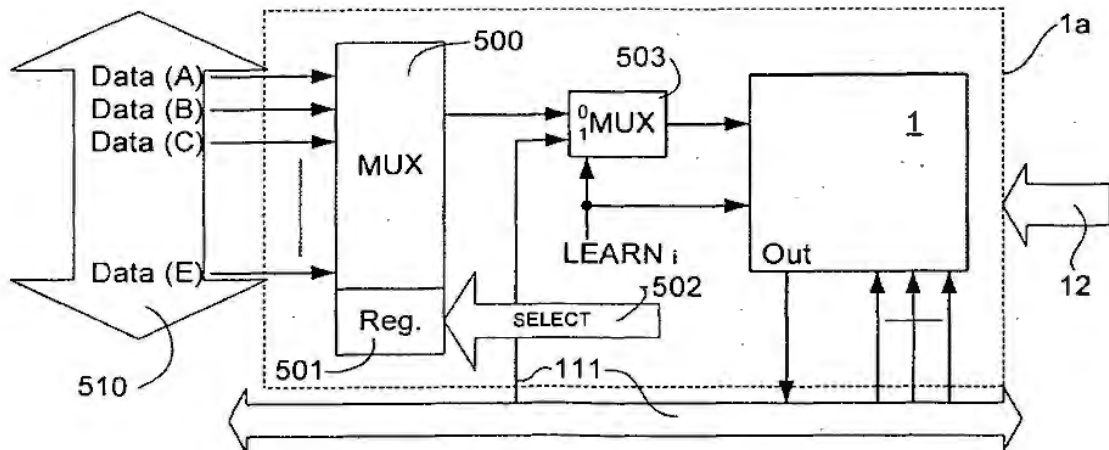

FIG. 30

FIG. 31a



26/31

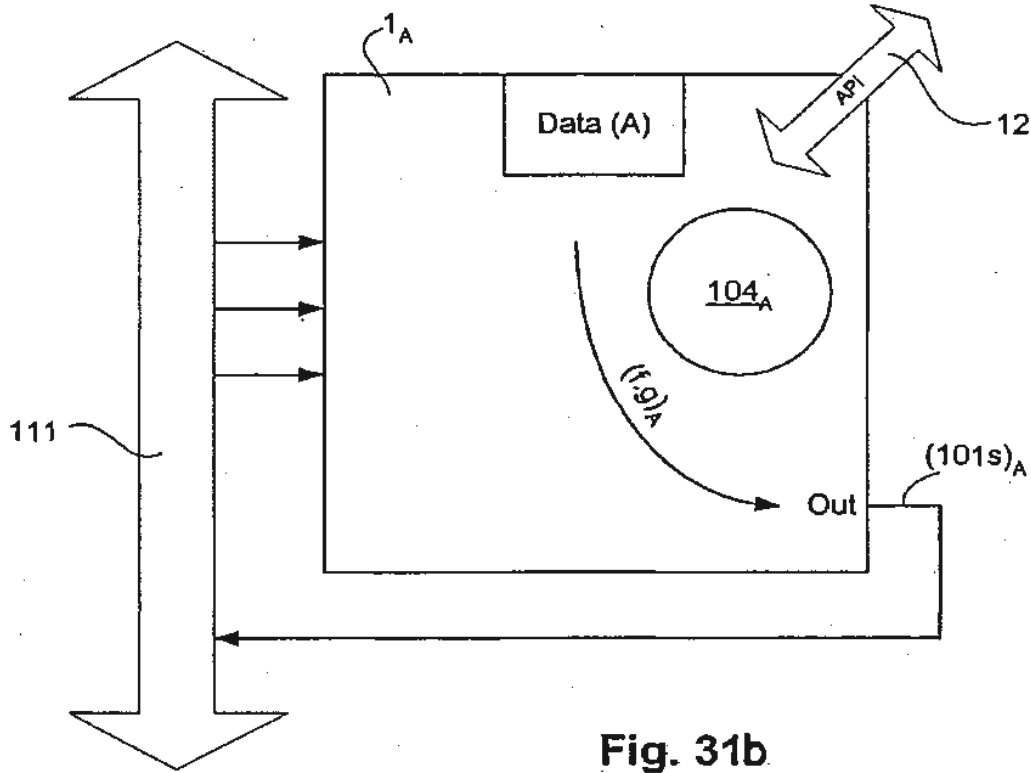

Fig. 31b

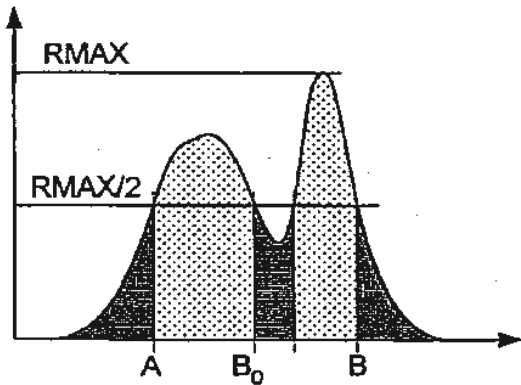

Fig 13b

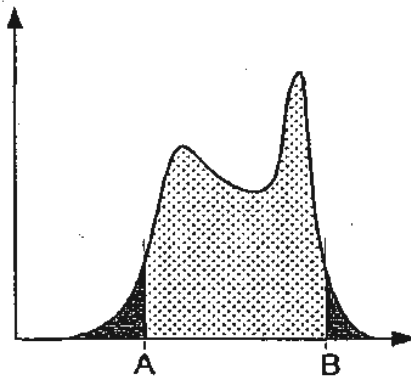

Fig 13c

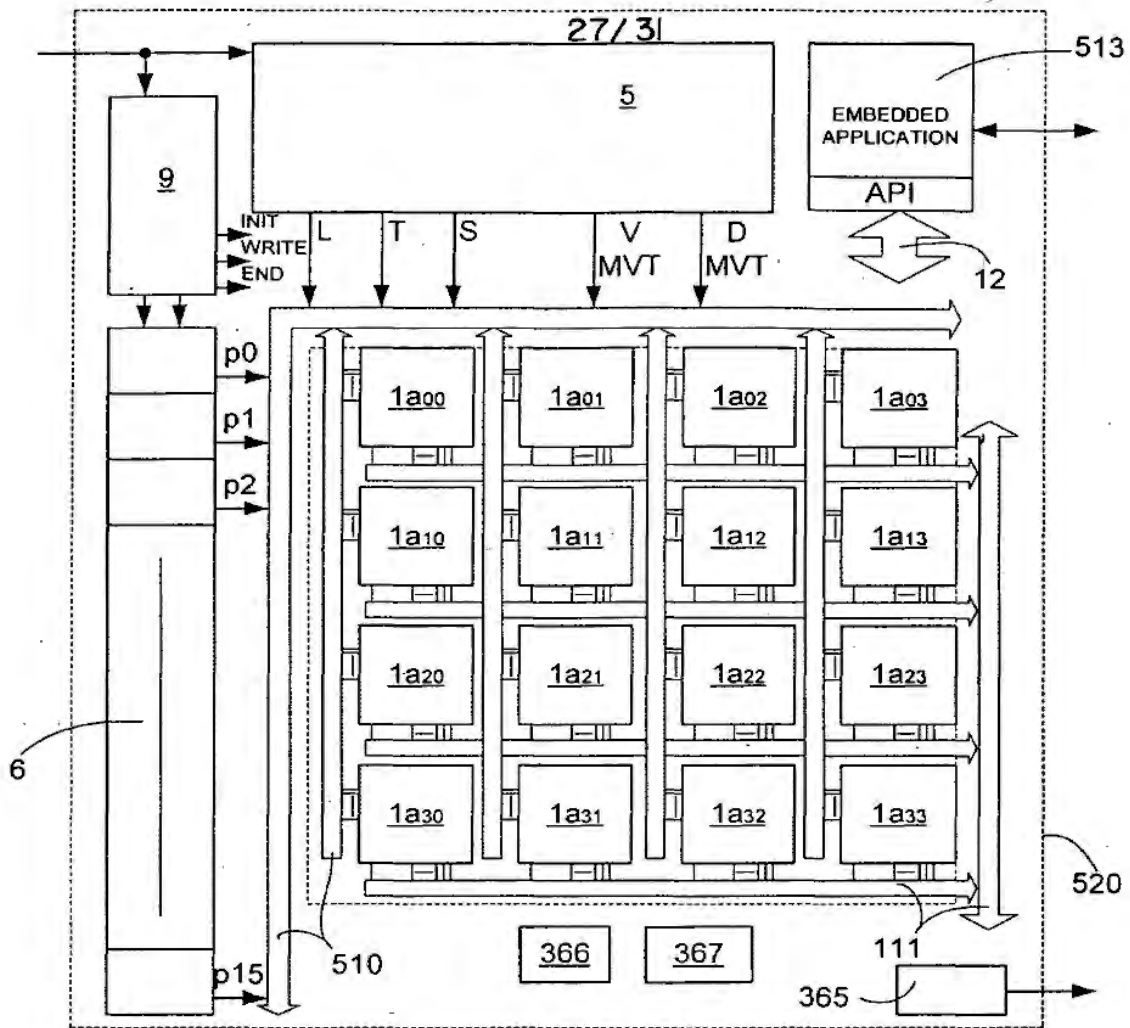

FIG. 32

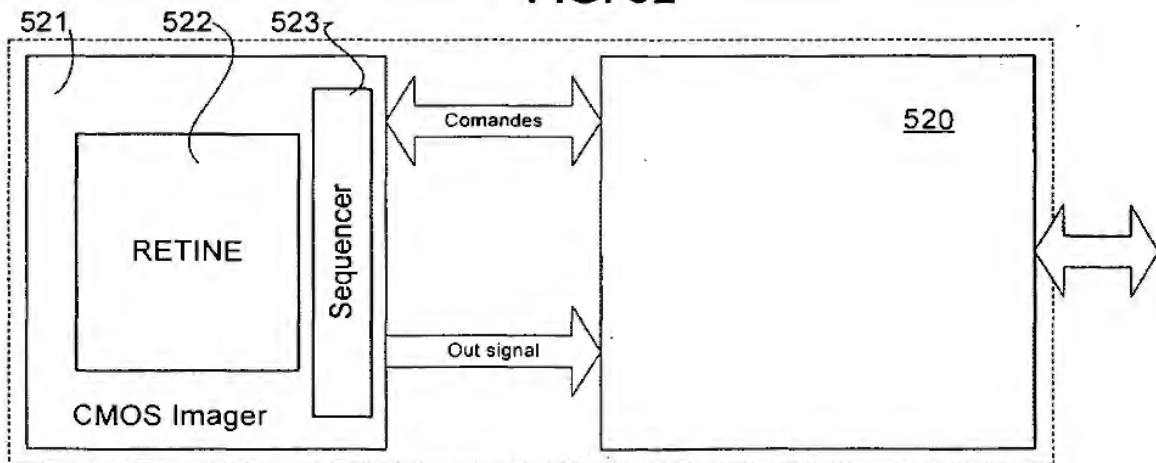

FIG. 33

28/31

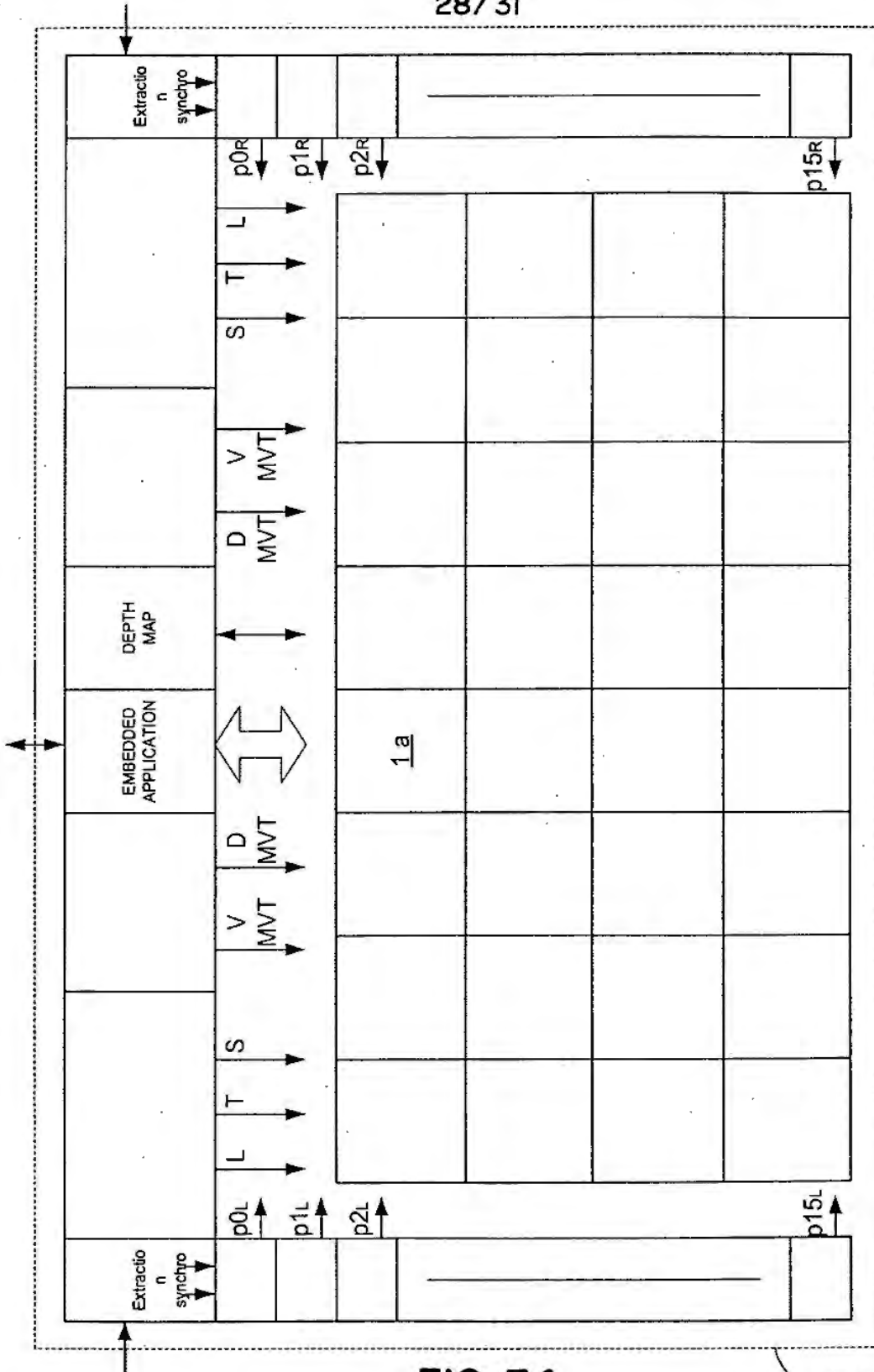

FIG. 34

530

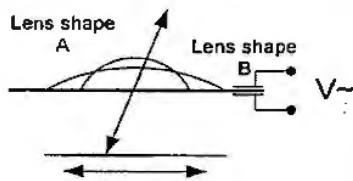
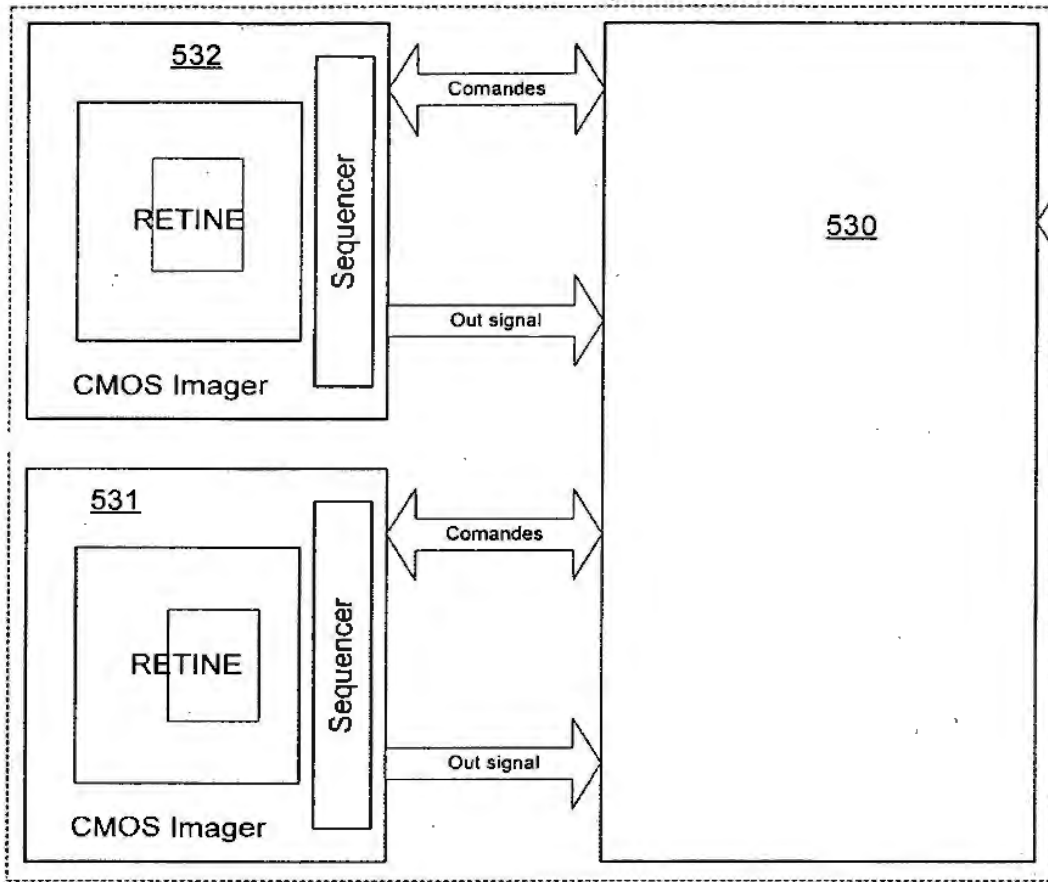
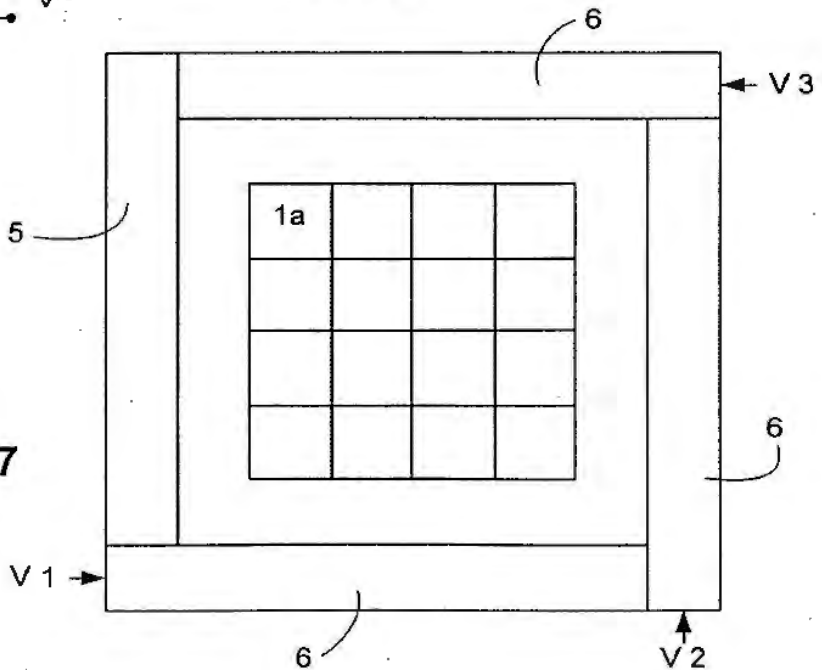

FIG. 36

FIG. 35

FIG. 37



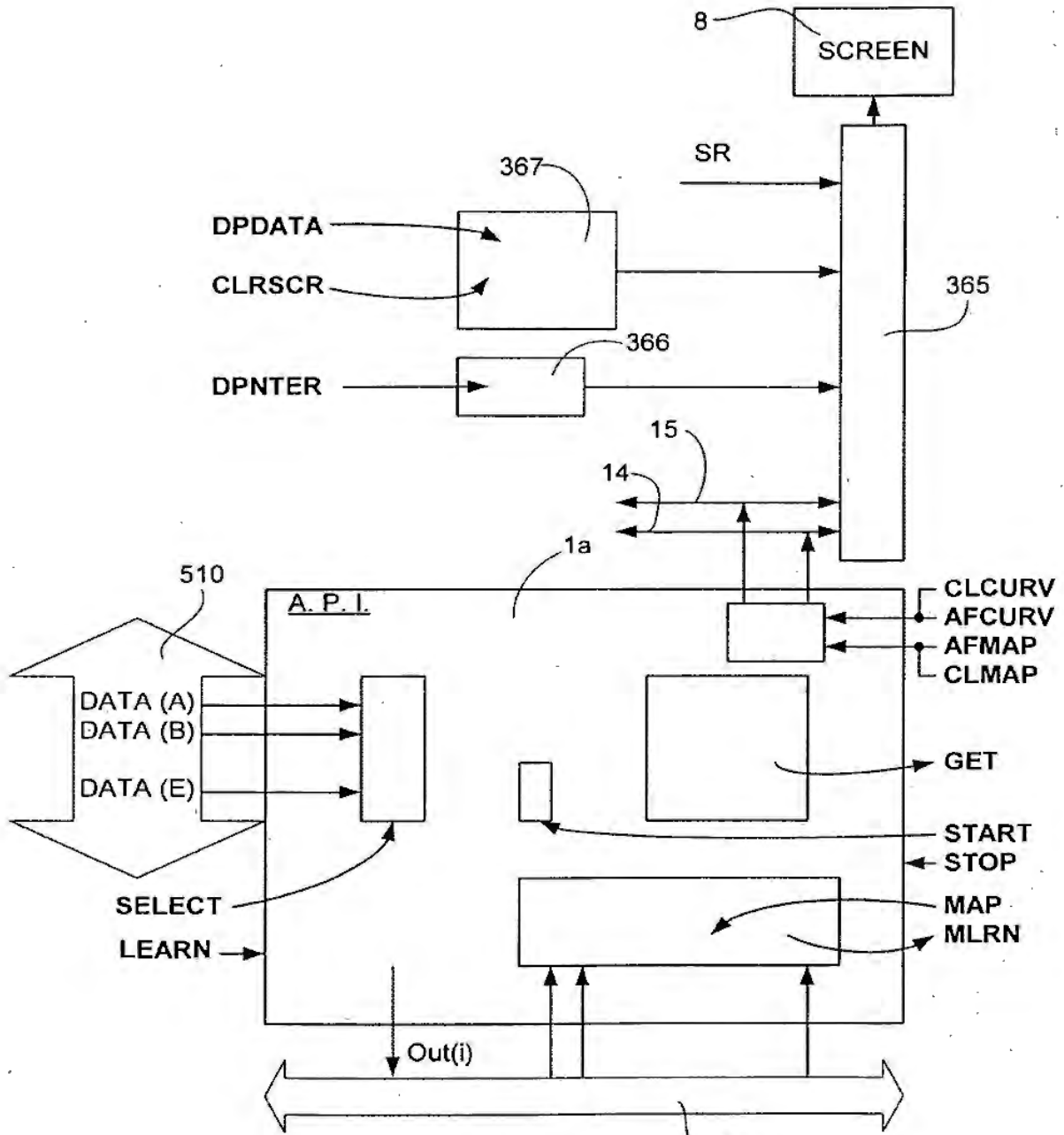

FIG. 38

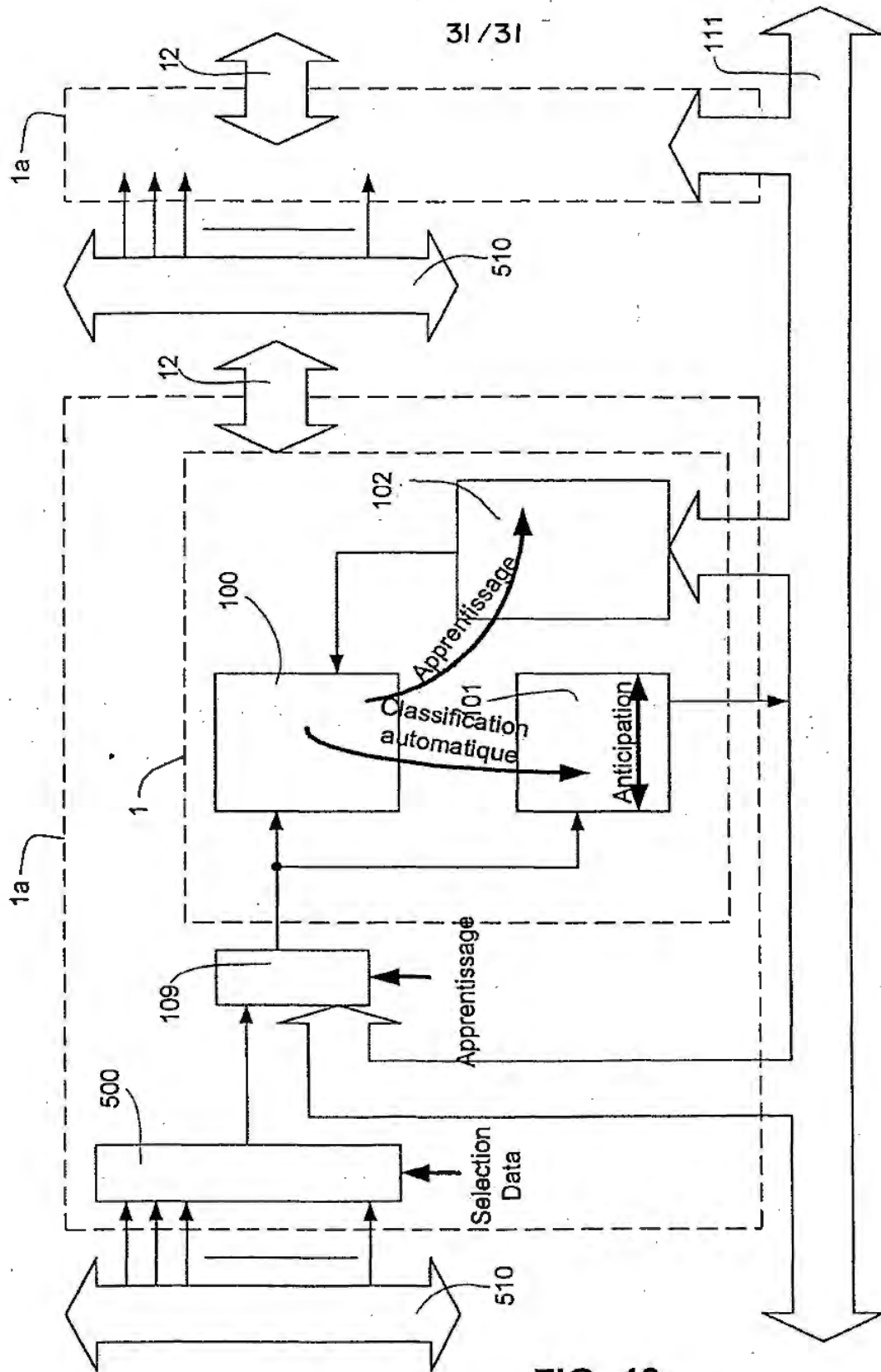

FIG. 40



PART B - FEE(S) TRANSMITTAL

Complete and send this form, together with applicable fee(s), to: **Mail** Mail Stop ISSUE FEE
Commissioner for Patents
P.O. Box 1450
Alexandria, Virginia 22313-1450
or Fax (703) 746-4000

INSTRUCTIONS: This form should be used for transmitting the ISSUE FEE and PUBLICATION FEE (if required). Blocks 1 through 5 should be completed where appropriate. All further correspondence including the Patent, advance orders and notification of maintenance fees will be mailed to the current correspondence address as indicated unless corrected below or directed otherwise in Block 1, by (a) specifying a new correspondence address; and/or (b) indicating a separate "FEE ADDRESS" for maintenance fee notifications.

CURRENT CORRESPONDENCE ADDRESS (Note: Use Block 1 for any change of address)

20350 7590 10/06/2004
TOWNSEND AND TOWNSEND AND CREW, LLP
TWO EMBARCADERO CENTER
EIGHTH FLOOR
SAN FRANCISCO, CA 94111-3834

Note: A certificate of mailing can only be used for domestic mailings of the Fee(s) Transmittal. This certificate cannot be used for any other accompanying papers. Each additional paper, such as an assignment or formal drawing, must have its own certificate of mailing or transmission.

Certificate of Mailing or Transmission
 I hereby certify that this Fee(s) Transmittal is being deposited with the United States Postal Service with sufficient postage for first class mail in an envelope addressed to the Mail Stop ISSUE FEE address above, or being facsimile transmitted to the USPTO (703) 746-4000, on the date indicated below.

Sylvia E. Arnold	(Depositor's name)
<i>Sylvia E. Arnold</i>	(Signature)
January 6, 2005	(Date)

APPLICATION NO.	FILING DATE	FIRST NAMED INVENTOR	ATTORNEY DOCKET NO.	CONFIRMATION NO.
09/792,436	02/23/2001	Patrick Pirim	20046H-000100	9956

TITLE OF INVENTION: METHOD AND DEVICE FOR AUTOMATIC VISUAL PERCEPTION

APPLN. TYPE	SMALL ENTITY	ISSUE FEE	PUBLICATION FEE	TOTAL FEE(S) DUE	DATE DUE
nonprovisional	NO	\$1,400	\$300	\$1,700	01/06/2005

EXAMINER	ART UNIT	CLASS-SUBCLASS
DAVIS, GEORGE B	2121	706-020000

1. Change of correspondence address or indication of "Fee Address" (37 CFR 1.363).
 Change of correspondence address (or Change of Correspondence Address form PTO/SB/122) attached.
 "Fee Address" indication (or "Fee Address" Indication form PTO/SB/47; Rev 03-02 or more recent) attached. Use of a Customer Number is required.
2. For printing on the patent front page, list
 (1) the names of up to 3 registered patent attorneys or agents OR, alternatively,
 (2) the name of a single firm (having as a member a registered attorney or agent) and the names of up to 2 registered patent attorneys or agents. If no name is listed, no name will be printed.
- TOWNSEND and TOWNSEND and CREW LLP
 1
 Gerald T. Gray
 2
 3

3. ASSIGNEE NAME AND RESIDENCE DATA TO BE PRINTED ON THE PATENT (print or type)

PLEASE NOTE: Unless an assignee is identified below, no assignee data will appear on the patent. If an assignee is identified below, the document has been filed for recordation as set forth in 37 CFR 3.11. Completion of this form is NOT a substitute for filing an assignment.

(A) NAME OF ASSIGNEE
 Holding B.E.V.S.A.

(B) RESIDENCE: (CITY and STATE OR COUNTRY)
 Luxembourg

01/13/2005 AMONDAF2 00000005 201430 09792436
 01 FC:1501 1400.00 DA
 02 FC:1504 300.00 DA
 03 FC:8001 30.00 DA

Please check the appropriate assignee category or categories (will not be printed on the patent): Individual Corporation or other private group entity Government

4a. The following fee(s) are enclosed:

- Issue Fee
 Publication Fee (No small entity discount permitted)
 Advance Order - # of Copies 10

4b. Payment of Fee(s):

- A check in the amount of the fee(s) is enclosed.
 Payment by credit card. Form PTO-2038 is attached.
 The Director is hereby authorized by charge the required fee(s), or credit any overpayment, to Deposit Account Number 20-1430 (enclose an extra copy of this form).

5. Change in Entity Status (from status indicated above)

- a. Applicant claims SMALL ENTITY status. See 37 CFR 1.27. b. Applicant is no longer claiming SMALL ENTITY status. See 37 CFR 1.27(g)(2).

The Director of the USPTO is requested to apply the Issue Fee and Publication Fee (if any) or to re-apply any previously paid issue fee to the application identified above. NOTE: The Issue Fee and Publication Fee (if required) will not be accepted from anyone other than the applicant, a registered attorney or agent, or the assignee or other party in interest as shown by the records of the United States Patent and Trademark Office.

Authorized Signature Gerald T. Gray Date January 6, 2005
 Typed or printed name Gerald T. Gray Registration No. 41,797

This collection of information is required by 37 CFR 1.311. The information is required to obtain or retain a benefit by the public which is to file (and by the USPTO to process) an application. Confidentiality is governed by 35 U.S.C. 122 and 37 CFR 1.14. This collection is estimated to take 12 minutes to complete, including gathering, preparing, and submitting the completed application form to the USPTO. Time will vary depending upon the individual case. Any comments on the amount of time you require to complete this form and/or suggestions for reducing this burden, should be sent to the Chief Information Officer, U.S. Patent and Trademark Office, U.S. Department of Commerce, P.O. Box 1450, Alexandria, Virginia 22313-1450. DO NOT SEND FEES OR COMPLETED FORMS TO THIS ADDRESS. SEND TO: Commissioner for Patents, P.O. Box 1450, Alexandria, Virginia 22313-1450.

Under the Paperwork Reduction Act of 1995, no persons are required to respond to a collection of information unless it displays a valid OMB control number.

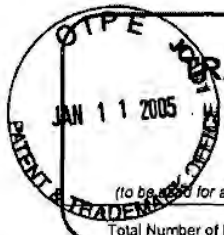

TRANSMITTAL FORM

(to be used for all correspondence after initial filing)

Total Number of Pages in This Submission

Application Number	09/792,436
Filing Date	February 23, 2001
First Named Inventor	Pirim, Patrick
Art Unit	2121
Examiner Name	George B. Davis
Attorney Docket Number	20046H-000100US

ENCLOSURES (Check all that apply)

<input type="checkbox"/> Fee Transmittal Form <input type="checkbox"/> Fee Attached	<input type="checkbox"/> Drawing(s) <input type="checkbox"/> Licensing-related Papers	<input type="checkbox"/> After Allowance Communication to TC <input type="checkbox"/> Appeal Communication to Board of Appeals and Interferences
<input type="checkbox"/> Amendment/Reply <input type="checkbox"/> After Final <input type="checkbox"/> Affidavits/declaration(s)	<input type="checkbox"/> Petition <input type="checkbox"/> Petition to Convert to a Provisional Application <input type="checkbox"/> Power of Attorney, Revocation Change of Correspondence Address	<input type="checkbox"/> Appeal Communication to TC (Appeal Notice, Brief, Reply Brief) <input type="checkbox"/> Proprietary Information <input type="checkbox"/> Status Letter
<input type="checkbox"/> Extension of Time Request <input type="checkbox"/> Express Abandonment Request <input type="checkbox"/> Information Disclosure Statement	<input type="checkbox"/> Terminal Disclaimer <input type="checkbox"/> Request for Refund <input type="checkbox"/> CD, Number of CD(s) _____ <input type="checkbox"/> Landscape Table on CD	<input checked="" type="checkbox"/> Other Enclosure(s) (please identify below): Return Postcard Communication Part B - Fee(s) Transmittal
<input type="checkbox"/> Certified Copy of Priority Document(s) <input type="checkbox"/> Reply to Missing Parts/ Incomplete Application <input type="checkbox"/> Reply to Missing Parts under 37 CFR 1.52 or 1.53	Remarks: The Commissioner is authorized to charge any additional fees to Deposit Account 20-1430.	

SIGNATURE OF APPLICANT, ATTORNEY, OR AGENT

Firm Name	Townsend and Townsend and Crew LLP		
Signature			
Printed name	Gerald T. Gray		
Date	January 6, 2005	Reg. No.	41,797

CERTIFICATE OF TRANSMISSION/MAILING

I hereby certify that this correspondence is being deposited with the United States Postal Service with sufficient postage as first class mail in an envelope addressed to: Commissioner for Patents, P.O. Box 1450, Alexandria, VA 22313-1450 on the date shown below.

Signature			
Typed or printed name	Sylvia E. Arnold	Date	January 6, 2005



I hereby certify that this correspondence is being deposited with the United States Postal Service as first class mail in an envelope addressed to:

PATENT
Attorney Docket No.: 20046H-000100US
Client Ref. No.: 308L US 3772

Mail Stop Issue Fee
Commissioner for Patents
P.O. Box 1450
Alexandria, VA 22313-1450

On January 6, 2005

TOWNSEND and TOWNSEND and CREW LLP

By: Sylvia E. Arnold
Sylvia E. Arnold

IN THE UNITED STATES PATENT AND TRADEMARK OFFICE

In re application of:

Patrick Pirim

Application No.: 09/792,436

Filed: February 23, 2001

For: METHOD AND DEVICE FOR
AUTOMATIC VISUAL PERCEPTION

Customer No.: 20350

Confirmation No. 9956

Examiner: George B. Davis

Technology Center/Art Unit: 2121

COMMUNICATION

Mail Stop Issue Fee
Commissioner for Patents
P.O. Box 1450
Alexandria, VA 22313-1450

Sir:

In view of the Supplemental Notice of Allowance mailed December 30, 2004, the required drawings will be submitted at a later date, but before the revised deadline of March 30, 2005.

Respectfully submitted,

Gerald T. Gray
Gerald T. Gray
Reg. No. 41,797

TOWNSEND and TOWNSEND and CREW LLP
Two Embarcadero Center, Eighth Floor
San Francisco, California 94111-3834
Tel: 925-472-5000
Fax: 415-576-0300
GTG:sea
60392347 v1



UNITED STATES PATENT AND TRADEMARK OFFICE

UNITED STATES DEPARTMENT OF COMMERCE
United States Patent and Trademark Office
Address: COMMISSIONER FOR PATENTS
P. O. Box 1450
Alexandria, Virginia 22313-1450
www.uspto.gov

APPLICATION NO.	FILING DATE	FIRST NAMED INVENTOR	ATTORNEY DOCKET NO.	CONFIRMATION NO.
09/792,436	02/23/2001	Patrick Pirim	20046H-000100	9956

20350 7590 12/30/2004

TOWNSEND AND TOWNSEND AND CREW, LLP
TWO EMBARCADERO CENTER
EIGHTH FLOOR
SAN FRANCISCO, CA 94111-3834

EXAMINER

DAVIS, GEORGE B

ART UNIT PAPER NUMBER

2121

DATE MAILED: 12/30/2004

Please find below and/or attached an Office communication concerning this application or proceeding.

**Supplemental
Notice of Allowability**

Application No. 09/792,436	Applicant(s) PIRIM, PATRICK	
Examiner George Davis	Art Unit 2121	

-- The MAILING DATE of this communication appears on the cover sheet with the correspondence address--
All claims being allowable, PROSECUTION ON THE MERITS IS (OR REMAINS) CLOSED in this application. If not included herewith (or previously mailed), a Notice of Allowance (PTOL-85) or other appropriate communication will be mailed in due course. **THIS NOTICE OF ALLOWABILITY IS NOT A GRANT OF PATENT RIGHTS.** This application is subject to withdrawal from issue at the initiative of the Office or upon petition by the applicant. See 37 CFR 1.313 and MPEP 1308.

1. This communication is responsive to _____.
2. The allowed claim(s) is/are 1-29.
3. The drawings filed on _____ are accepted by the Examiner.
4. Acknowledgment is made of a claim for foreign priority under 35 U.S.C. § 119(a)-(d) or (f).
 - a) All b) Some* c) None of the:
 1. Certified copies of the priority documents have been received.
 2. Certified copies of the priority documents have been received in Application No. _____.
 3. Copies of the certified copies of the priority documents have been received in this national stage application from the International Bureau (PCT Rule 17.2(a)).* Certified copies not received: _____.

Applicant has THREE MONTHS FROM THE "MAILING DATE" of this communication to file a reply complying with the requirements noted below. Failure to timely comply will result in ABANDONMENT of this application.
THIS THREE-MONTH PERIOD IS NOT EXTENDABLE.

5. A SUBSTITUTE OATH OR DECLARATION must be submitted. Note the attached EXAMINER'S AMENDMENT or NOTICE OF INFORMAL PATENT APPLICATION (PTO-152) which gives reason(s) why the oath or declaration is deficient.
6. CORRECTED DRAWINGS (as "replacement sheets") must be submitted.
 - (a) including changes required by the Notice of Draftsperson's Patent Drawing Review (PTO-948) attached
 - 1) hereto or 2) to Paper No./Mail Date _____.
 - (b) including changes required by the attached Examiner's Amendment / Comment or in the Office action of Paper No./Mail Date 3/26/2004.Identifying indicia such as the application number (see 37 CFR 1.84(c)) should be written on the drawings in the front (not the back) of each sheet. Replacement sheet(s) should be labeled as such in the header according to 37 CFR 1.121(d).
7. DEPOSIT OF and/or INFORMATION about the deposit of BIOLOGICAL MATERIAL must be submitted. Note the attached Examiner's comment regarding REQUIREMENT FOR THE DEPOSIT OF BIOLOGICAL MATERIAL.

Attachment(s)

- | | |
|---|--|
| 1. <input type="checkbox"/> Notice of References Cited (PTO-892) | 5. <input type="checkbox"/> Notice of Informal Patent Application (PTO-152) |
| 2. <input type="checkbox"/> Notice of Draftsperson's Patent Drawing Review (PTO-948) | 6. <input checked="" type="checkbox"/> Interview Summary (PTO-413),
Paper No./Mail Date <u>12/27/2004</u> . |
| 3. <input type="checkbox"/> Information Disclosure Statements (PTO-1449 or PTO/SB/08),
Paper No./Mail Date _____ | 7. <input type="checkbox"/> Examiner's Amendment/Comment |
| 4. <input type="checkbox"/> Examiner's Comment Regarding Requirement for Deposit
of Biological Material | 8. <input type="checkbox"/> Examiner's Statement of Reasons for Allowance |
| | 9. <input type="checkbox"/> Other _____. |

George Davis
Primary Examiner
Art Unit: 2121

Interview Summary	Application N .	Applicant(s)	
	09/792,436	PIRIM, PATRICK	
	Examiner	Art Unit	
	George Davis	2121	

All participants (applicant, applicant's representative, PTO personnel):

(1) George Davis. (3)_____.

(2) Gerald T. Gray. (4)_____.

Date of Interview: 27 December 2004.

Type: a) Telephonic b) Video Conference
c) Personal [copy given to: 1) applicant 2) applicant's representative]

Exhibit shown or demonstration conducted: d) Yes e) No.
If Yes, brief description: _____.

Claim(s) discussed: none.

Identification of prior art discussed: none.

Agreement with respect to the claims f) was reached. g) was not reached. h) N/A.

Substance of Interview including description of the general nature of what was agreed to if an agreement was reached, or any other comments: Examiner and Gerald T. Gray agreed to make changes shown in Supplemental Notice of Allowability.

(A fuller description, if necessary, and a copy of the amendments which the examiner agreed would render the claims allowable, if available, must be attached. Also, where no copy of the amendments that would render the claims allowable is available, a summary thereof must be attached.)

THE FORMAL WRITTEN REPLY TO THE LAST OFFICE ACTION MUST INCLUDE THE SUBSTANCE OF THE INTERVIEW. (See MPEP Section 713.04). If a reply to the last Office action has already been filed, APPLICANT IS GIVEN ONE MONTH FROM THIS INTERVIEW DATE, OR THE MAILING DATE OF THIS INTERVIEW SUMMARY FORM, WHICHEVER IS LATER, TO FILE A STATEMENT OF THE SUBSTANCE OF THE INTERVIEW. See Summary of Record of Interview requirements on reverse side or on attached sheet.

Examiner Note: You must sign this form unless it is an Attachment to a signed Office action.

Examiner's signature, if required



IFW/2121\$

PTO/SB/21 (04-04)

TRANSMITTAL FORM <small>(to be used for all correspondence after initial filing)</small>	Application Number	09/792,436 ✓	
	Filing Date	February 23, 2001	
	First Named Inventor	Pirim, Patrick	
	Art Unit	2121	
	Examiner Name	George B. Davis	
Total Number of Pages in This Submission	5	Attorney Docket Number	20046H-000100US

ENCLOSURES (Check all that apply)		
<input checked="" type="checkbox"/> Fee Transmittal Form	<input type="checkbox"/> Drawing(s)	<input type="checkbox"/> After Allowance Communication to Technology Center (TC)
<input type="checkbox"/> Fee Attached	<input type="checkbox"/> Licensing-related Papers	<input type="checkbox"/> Appeal Communication to Board of Appeals and Interferences
<input type="checkbox"/> Amendment/Reply	<input type="checkbox"/> Petition	<input type="checkbox"/> Appeal Communication to TC (Appeal Notice, Brief, Reply Brief)
<input type="checkbox"/> After Final	<input type="checkbox"/> Petition to Convert to a Provisional Application	<input type="checkbox"/> Proprietary Information
<input type="checkbox"/> Affidavits/declaration(s)	<input type="checkbox"/> Power of Attorney, Revocation Change of Correspondence Address	<input type="checkbox"/> Status Letter
<input type="checkbox"/> Extension of Time Request	<input type="checkbox"/> Terminal Disclaimer	<input checked="" type="checkbox"/> Other Enclosure(s) (please identify below):
<input type="checkbox"/> Express Abandonment Request	<input type="checkbox"/> Request for Refund	Return Postcard
<input checked="" type="checkbox"/> Information Disclosure Statement	<input type="checkbox"/> CD, Number of CD(s)	References Cited (5)
<input type="checkbox"/> Certified Copy of Priority Document(s)	Remarks: The Commissioner is authorized to charge any additional fees to Deposit Account 20-1430.	
<input type="checkbox"/> Response to Missing Parts/Incomplete Application		
<input type="checkbox"/> Response to Missing Parts under 37 CFR 1.52 or 1.53		

SIGNATURE OF APPLICANT, ATTORNEY, OR AGENT	
Firm or Individual name	Townsend and Townsend and Crew LLP Gerald T. Gray Reg. No. 41,797
Signature	<i>Gerald T. Gray</i>
Date	October 28, 2004

CERTIFICATE OF TRANSMISSION/MAILING	
I hereby certify that this correspondence is being deposited with the United States Postal Service with sufficient postage as first class mail in an envelope addressed to: Commissioner for Patents, P.O. Box 1450, Alexandria, VA 22313-1450 on the date shown below.	
Typed or printed name	Marta R. Vanegas
Signature	<i>Marta Vanegas</i>
Date	October 28, 2004



FEE TRANSMITTAL for FY 2005

Effective 10/01/2004. Patent fees are subject to annual revision.

Applicant claims small entity status. See 37 CFR 1.27

TOTAL AMOUNT OF PAYMENT (\$) 180

Complete if Known

Application Number	09/792,436
Filing Date	February 23, 2001
First Named Inventor	Pirim, Patrick
Examiner Name	George B. Davis
Art Unit	2121
Attorney Docket No.	20046H-000100US

METHOD OF PAYMENT (check all that apply)

Check Credit Card Money Order Other None

Deposit Account:

Deposit Account Number: 20-1430

Deposit Account Name: Townsend and Townsend and Crew LLP

The Director is authorized to: (check all that apply)

Charge fee(s) indicated below Credit any overpayments

Charge any additional fee(s) or any underpayment of fee(s)

Charge fee(s) indicated below, except for the filing fee to the above-identified deposit account.

FEE CALCULATION

1. BASIC FILING FEE

Large Entity		Small Entity		Fee Description	Fee Paid
Fee Code	Fee (\$)	Fee Code	Fee (\$)		
1001	790	2001	395	Utility filing fee	
1002	350	2002	175	Design filing fee	
1003	550	2003	275	Plant filing fee	
1004	790	2004	395	Reissue filing fee	
1005	160	2005	80	Provisional filing fee	
SUBTOTAL (1)					\$

2. EXTRA CLAIM FEES FOR UTILITY AND REISSUE

	Extra Claims	Fee from below	Fee Paid
Total Claims	..*	X	
Independent Claims	..*	X	
Multiple Dependent		X	

Large Entity		Small Entity		Fee Description	Fee Paid
Fee Code	Fee (\$)	Fee Code	Fee (\$)		
1202	18	2202	9	Claims in excess of 20	
1201	88	2201	44	Independent claims in excess of 3	
1203	300	2203	150	Multiple dependent claim, if not paid	
1204	88	2204	44	** Reissue independent claims over original patent	
1205	18	2205	9	** Reissue claims in excess of 20 and over original patent	
SUBTOTAL (2)					\$

*or number previously paid, if greater; For Reissues, see above

FEE CALCULATION (continued)

Large Entity		Small Entity		Fee Description	Fee Paid
Fee Code	Fee (\$)	Fee Code	Fee (\$)		
1051	130	2051	65	Surcharge - late filing fee or oath	
1052	50	2052	25	Surcharge - late provisional filing fee or cover sheet	
1053	130	1053	130	Non-English specification	
1812	2,520	1812	2,520	For filing a request for <i>ex parte</i> reexamination	
1804	920*	1804	920*	Requesting publication of SIR prior to Examiner action	
1805	1,840*	1805	1,840*	Requesting publication of SIR after Examiner action	
1251	110	2251	55	Extension for reply within first month	
1252	430	2252	215	Extension for reply within second month	
1253	980	2253	490	Extension for reply within third month	
1254	1,530	2254	785	Extension for reply within fourth month	
1255	2,080	2255	1,040	Extension for reply within fifth month	
1401	340	2401	170	Notice of Appeal	
1402	340	2402	170	Filing a brief in support of an appeal	
1403	300	2403	150	Request for oral hearing	
1451	1,510	1451	1,510	Petition to institute a public use proceeding	
1452	110	2452	55	Petition to revive - unavoidable	
1453	1,330	2453	665	Petition to revive - unintentional	
1501	1,370	2501	685	Utility issue fee (or reissue)	
1502	490	2502	245	Design issue fee	
1503	660	2503	330	Plant issue fee	
1460	130	1460	130	Petitions to the Commissioner	
1807	50	1807	50	Processing fee under 37 CFR 1.17(q)	
1806	180	1806	180	Submission of Information Disclosure Stmt	180
8021	40	8021	40	Recording each patent assignment per property (times number of properties)	
1809	790	2809	395	Filing a submission after final rejection (37 CFR § 1.129(a))	
1810	790	2810	395	For each additional invention to be examined (37 CFR § 1.129(b))	
1801	790	2801	395	Request for Continued Examination (RCE)	
1802	900	1802	900	Request for expedited examination of a design application	
Other fee (specify)					
*Reduced by Basic Filing Fee Paid				SUBTOTAL (3)	\$180

SUBMITTED BY		Complete (if applicable)			
Name (Print/Type)	Gerald T. Gray	Registration No. (Attorney/Agent)	41,797	Telephone	925-472-5000
Signature	<i>Gerald T. Gray</i>	Date	October 28, 2004		

WARNING: Information on this form may become public. Credit card information should not be included on this form. Provide credit card information and authorization on PTO-2038.



I hereby certify that this correspondence is being deposited with the United States Postal Service as first class mail in an envelope addressed to:

Commissioner for Patents
P.O. Box 1450
Alexandria, VA 22313-1450

PATENT
Attorney Docket No.: 20046H-000100US
Client Reference No.: 308L US 3772

On October 28, 2004

TOWNSEND and TOWNSEND and CREW LLP

By: Marta Vanegas

IN THE UNITED STATES PATENT AND TRADEMARK OFFICE

In re application of:

Patrick Pirim

Application No.: 09/792,436

Filed: February 23, 2001

For: METHOD AND DEVICE FOR
AUTOMATIC VISUAL PERCEPTION

Group Director: 2121

Examiner: George B. Davis

Art Unit: 2121

SUPPLEMENTAL INFORMATION
DISCLOSURE STATEMENT UNDER 37
CFR §1.97 and §1.98

Commissioner for Patents
P.O. Box 1450
Alexandria, VA 22313-1450

Sir:

The references cited on attached form PTO/SB/08A are being called to the attention of the Examiner. Copies of the references are enclosed.

It is respectfully requested that the cited references be expressly considered during the prosecution of this application, and the references be made of record therein and appear among the "references cited" on any patent to issue therefrom.

As provided for by 37 CFR 1.97(g) and (h), no inference should be made that the information and references cited are prior art merely because they are in this statement and no representation is being made that a search has been conducted or that this statement encompasses all the possible relevant information.

11/02/2004 DEKXANU1 00000003 201430 09792436

01 FC:1006 160.CO 03

This IDS is being filed on or before payment of the issue fee.

CERTIFICATION

I hereby certify that no item of information contained in the Information Disclosure Statement filed herewith was cited in a communication from a foreign patent office in a counterpart foreign application, and, to my knowledge after making reasonable inquiry, no item of information contained in this Information Disclosure Statement was known to any individual designated in 37 CFR 1.56(c) more than three months prior to the filing of this Information Disclosure Statement.

Please charge the IDS fee of \$180 to Deposit Account No. 20-1430. Please deduct any additional fees from, or credit any overpayment to, the above-noted Deposit Account.

Respectfully submitted,

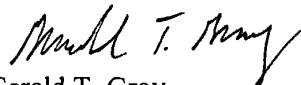
Gerald T. Gray
Reg. No. 41,797

TOWNSEND and TOWNSEND and CREW LLP
Two Embarcadero Center, Eighth Floor
San Francisco, California 94111-3834
Tel: 925-472-5000
Fax: 925-472-8895
GTG:mrv

60342657 v1

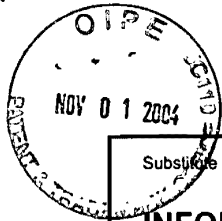

Substitute for form 1449A/PTO		Complete if Known	
INFORMATION DISCLOSURE STATEMENT BY APPLICANT <i>(use as many sheets as necessary)</i>		Application Number	09/792,436
		Filing Date	February 23, 2001
		First Named Inventor	Pirim, Patrick
		Art Unit	2121
		Examiner Name	George B. Davis
Sheet	1	of	1
		Attorney Docket Number	20046H-000100US

U.S. PATENT DOCUMENTS+						
Examiner Initials*	Cite No. ¹	Document Number		Publication Date MM-DD-YYYY	Name of Patentee or Applicant of Cited Document	Pages, Columns, Lines, Where Relevant Passages or Relevant Figures Appear
		Number	Kind Code ² (if known)			
	1	4,783,828		11-08-1988	Sadjadi	
	2	5,278,921 A		01-11-1994	Nakamura et al.	
	3	5,774,581 A		06-30-1998	Fassnacht et al.	
	4	6,597,738 B1		07-22-2003	Park et al.	

FOREIGN PATENT DOCUMENTS								
Examiner Initials*	Cite No. ¹	Foreign Patent Document			Publication Date MM-DD-YYYY	Name of Patentee or Applicant of Cited Document	Pages, Columns, Lines, Where Relevant Passages or Relevant Figures Appear	T ⁶
		Country Code ³	Number ⁴	Kind Code ⁵ (if known)				
	5	JP	06-205780	A	07-26-1994	Aloka Co. Ltd.		<input type="checkbox"/>
								<input type="checkbox"/>
								<input type="checkbox"/>
								<input type="checkbox"/>
								<input type="checkbox"/>
								<input type="checkbox"/>
								<input type="checkbox"/>

Examiner Signature		Date Considered	
--------------------	--	-----------------	--

*EXAMINER: Initial if reference considered, whether or not citation is in conformance with MPEP 809. Draw line through citation if not in conformance and not considered. Include copy of this form with next communication to applicant. ¹ Applicant's unique citation designation number (optional). ² Kind Codes of U.S. Patent Documents at www.uspto.gov or MPEP 901.04. ³ Enter Office that issued the document, by the two-letter code (WIPO Standard ST.3). ⁴ For Japanese patent documents, the indication of the year of the reign of the Emperor must precede the serial number of the patent document. ⁵ Kind of document by the appropriate symbols as indicated on the document under WIPO Standard ST. 18 if possible. ⁶ Applicant is to place a check mark here if English language Translation is attached.
60342657 v1

PATENT ABSTRACTS OF JAPAN

(11)Publication number : 06-205780
(43)Date of publication of application : 26.07.1994

(51)Int.Cl. A61B 8/14
H04N 5/31
H04N 5/57

(21)Application number : 05-003037 (71)Applicant : ALOKA CO LTD
(22)Date of filing : 12.01.1993 (72)Inventor : MURASHITA MASARU
MATSUNAKA TOSHIYUKI

(54) ULTRASONIC IMAGE PROCESSOR

(57)Abstract:

PURPOSE: To provide an ultrasonic image processor capable of retrieving the degree of the contrast of the remarked region and invariably making the contrast reinforcement suitable to the region.

CONSTITUTION: When two regions having a small density difference are to be clarified, the desired region is encircled with a frame, then a frame readout circuit 4 outputs the region extraction signal 101 to a frame memory 2. The frame memory 2 outputs the present image data of the prescribed region encircled by the frame to a histogram circuit 7 according to the region extracting signal 101. The histogram circuit 7 generates a histogram based on the present image data of the prescribed region encircled by the frame. This histogram is smoothed by a histogram smoothing circuit 11, and the peak value of the smoothed histogram is retrieved by a peak value retrieving circuit 15. A picture element value emphasizing circuit 3 determines a new density value based on the retrieved peak value and displays an image in the prescribed region centering on the remarked picture element encircled by the frame based on the new density value.

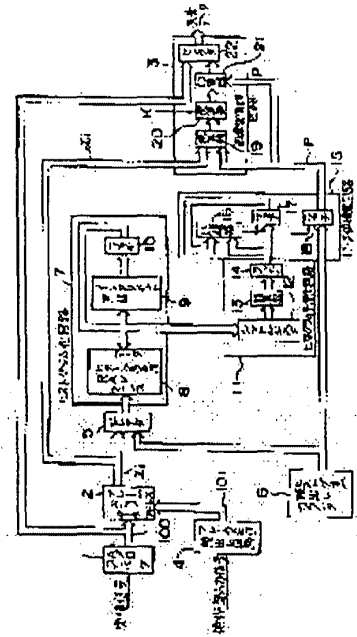

LEGAL STATUS

[Date of request for examination] 17.10.1994
[Date of sending the examiner's decision of rejection] 10.12.1996
[Kind of final disposal of application other than the examiner's decision of rejection or application converted registration]
[Date of final disposal for application]
[Patent number]
[Date of registration]
[Number of appeal against examiner's decision of rejection]
[Date of requesting appeal against examiner's decision of rejection]
[Date of extinction of right]

Copyright (C); 1998,2003 Japan Patent Office

(19)日本国特許庁(J P)

(12) 公開特許公報(A)

(11)特許出願公開番号

特開平6-205780

(43)公開日 平成6年(1994)7月26日

(51)InCl.	識別記号	庁内整理番号	F I	技術表示箇所
A 6 1 B 8/14		9361-4C		
H 0 4 N 5/31				
	5/57			

審査請求 未請求 請求項の数 1 O L (全 5 頁)

(21)出願番号	特願平5-3037	(71)出願人	390029791 アロカ株式会社 東京都三鷹市牟礼6丁目22番1号
(22)出願日	平成5年(1993)1月12日	(72)発明者	村下 賢 東京都三鷹市牟礼6丁目22番1号 アロカ株式会社内
		(72)発明者	松中 敏行 東京都三鷹市牟礼6丁目22番1号 アロカ株式会社内
		(74)代理人	弁理士 吉田 研二 (外2名)

(54)【発明の名称】 超音波画像処理装置

(57)【要約】

【目的】 注目する領域のコントラストの度合いを検索し、その領域に適したコントラスト強化を常時行える超音波画像処理装置を提供する。

【構成】 濃淡差の小さい2つの領域をはっきりさせる場合、所望の領域を枠で囲むと、フレームメモリ読出し回路4はフレームメモリ2へ領域抽出信号101を出力する。フレームメモリ2は領域抽出信号101に従い枠に囲まれた所定領域の現画像データをヒストグラム化回路7へ出力する。ヒストグラム化回路7は、枠に囲まれた所定領域の現画像データに基づきヒストグラムを作成する。このヒストグラムは、ヒストグラム平滑化回路11により平滑化され、平滑化されたヒストグラムは、ピーク値検索回路15によりそのピーク値Pが検索される。それから、画素値強調回路3は、検索されたピーク値Pに基づき新たな濃淡値を求め、新たな濃淡値により枠に囲まれた注目画素を中心とした所定領域の画像を表示する。

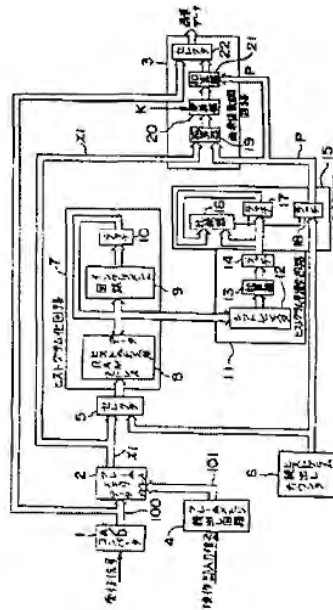

【特許請求の範囲】

【請求項1】 画素情報における注目画素を中心とした所定領域を囲む枠の範囲を選択し得る超音波画像処理装置において、前記所定領域内画素群のヒストグラムを作成するヒストグラム作成手段と、ヒストグラム作成手段により作成されたヒストグラムのピーク値を検索するピーク値検索手段と、予め記憶した濃淡値表により注目画素を中心とした所定領域のみをコントラスト強調処理を行う画素値強調手段と、を備え、枠選択手段により所定領域を枠で囲み、枠で囲んだ注目画素を中心とした所定領域のみにコントラスト強調を行うことを特徴とする超音波画像処理装置。

【発明の詳細な説明】

【0001】

【産業上の利用分野】本発明は、超音波診断装置に用いられる超音波画像処理装置に係り、特に画素情報における注目画素を中心とした所定領域を囲む枠の範囲を選択し得る超音波画像処理装置に関する。

【0002】

【従来技術】従来、超音波診断装置において、得られた超音波画像のうちで濃淡差の大きい2つの領域、例えば骨と内臓器官のように超音波の反射率が異なる場合、骨は白く表示されかつ内臓器官は灰色に表示されて濃淡差が大きいためにはっきり表示されるが、例えば肝臓と腎臓のように濃淡差の小さい2つの領域をはっきりさせる機能としてコントラスト調整やポストプロセス処理としてグレースケールバーの割当てを変化させる機能がある。

【0003】

【発明が解決しようとする課題】しかしながら、コントラスト調整やグレースケールバーの割当てを変化させる機能は、画面全体に対して行うものであり、画質が硬いという印象を与えてしまうという不具合がある。また、コントラスト調整やグレースケールバーの割当てを変化させる機能は、一度設定してしまつてそのままとなつてしまひ、時々刻々変化する超音波画像において、レベルの異なる濃淡差の小さい2つの領域をはっきりさせるためには、そのレベルに合わせて再設定しなければならず、その手間が煩雑であった。

【0004】本発明は、上記のような課題を解消するためになされたものであり、注目する領域のコントラストの度合いを検索し、その領域に適したコントラスト強化を常時行える超音波画像処理装置を提供することを目的とするものである。

【0005】

【課題を解決するための手段】本発明は、上述事情に鑑みなされたものであって、本発明に係る超音波画像処理装置は、画素情報における注目画素を中心とした所定領

域内画素群のヒストグラムを作成するヒストグラム作成手段と、ヒストグラム作成手段により作成されたヒストグラムのピーク値を検索するピーク値検索手段と、予め記憶した濃淡値表により注目画素のみをコントラスト強調処理を行う画素値強調手段と、を備え、枠選択手段により所定領域を枠で囲み、枠で囲んだ所定領域のみにコントラスト強調を行うことを特徴とするものである。

【0006】

【作用】上述構成に基づき、本発明に係る超音波画像処理装置は、枠選択手段により所定領域を枠で囲み、ヒストグラム作成手段により画素情報における注目画素を中心とした所定領域内画素群のヒストグラムを作成し、ヒストグラム作成手段により作成されたヒストグラムのピーク値をピーク値検索手段で検索し、画素値強調手段により予め記憶した濃淡値表により枠で囲んだ注目画素を中心とした所定領域のみにコントラスト強調処理を行い、リアルタイムに枠で囲んだ注目画素を中心とした所定領域に最適なコントラスト強調を行える。

【0007】

【実施例】以下、本発明の一実施例を図を用いて説明する。

【0008】図1は、本発明に係る超音波画像処理装置の構成を示すブロック図である。

【0009】超音波画像処理装置は、超音波受信信号（アナログ信号）をA/D変換するA/Dコンバータ1を有しており、A/Dコンバータ1には、A/D変換された1画面分の超音波受信信号（デジタル信号）100を記憶するフレームメモリ2と後述する画素値強調回路3とが接続されている。更に、超音波画像処理装置は、操作部（図示せず）からの入力信号により枠で囲んだ注目画素を中心とした所定領域を抽出するための領域抽出信号101をフレームメモリ2へ入力するフレームメモリ読み出し回路4を有しており、フレームメモリ2は、フレームメモリ読み出し回路4からの領域抽出信号（アドレス）に従い注目画素を中心とした所定領域のデータXiを出力する。

【0010】そして、フレームメモリ2には、後述する画素値強調回路3とセレクタ5とが接続されており、セレクタ5は、フレームメモリ2からの信号又はヒストグラム読み出しカウンタ6からの信号を選択するようになっている。更に、セレクタ5には、枠で囲んだ注目画素を中心とした所定領域のヒストグラムを作成するヒストグラム化回路7が接続されており、ヒストグラム化回路7は、ヒストグラム用RAM8と、インクリメント回路9と、ラッチ10とにより構成されている。

【0011】また、ヒストグラム化回路7には、作成したヒストグラムを平滑化するヒストグラム平滑化回路11が接続されており、ヒストグラム平滑化回路11は、シフトレジスタ12と、前後8個ずつのデータを加算する加算器13と、ラッチ14とにより構成されている。

そして、ヒストグラム平滑化回路11とヒストグラム読出しカウンタ6とは、ヒストグラム平滑化回路11により平滑化したヒストグラムのピーク値Pを検索するピーク値検索回路15が接続されており、ピーク値検索回路15は、前回のピーク値と今回のピーク値とを比較して今回のピーク値が大きい場合のみラッチ信号を出力する比較器16と、ラッチ17、18とにより構成されている。

【0012】更に、ピーク値検索回路15、フレームメモリ2及びA/Dコンバータ1には、枠で囲んだ注目画素を中心とした所定領域のコントラストを強調する画素値強調回路3が接続されており、画素値強調回路3は、枠で囲んだ注目画素を中心とした所定領域の現画像データXiからピーク値検索回路15により検索された前画像データのピーク値Pを減算する減算器19と、減算器19からの出力(Xi-P)にコントラスト強調定数Kを乗じる乗算器20と、乗算器20の出力K(Xi-P)にピーク値Pを加算する加算器21と、A/Dコンバータ1からの信号又は加算器21から出力される信号を選択するセレクタ22とにより構成されている。

【0013】なお、ヒストグラムは、図2に示すように、ガウス分布となり、このガウス分布はコントラストを上げるとガウス分布が広がり、コントラストを下げると狭くなるので、この特徴を応用して、図2に示すような現在のヒストグラムの形状を、図3に示すように、ピーク値を中心に広がるように変化させればコントラストを上げられる。すなわち、ヒストグラムの形状をピーク値を中心に広がるような濃淡値表を作成し、画像を再表示させればコントラストを上げられる。図2に示すようなヒストグラムが得られた場合、ピーク値をとる濃淡値をP、現在の各画素の濃淡値をXiとすると、新たな濃淡値Yiは次式により求められる。

$$【0014】 Y_i = K(X_i - P) + P$$

次に、本実施例の作用について説明する。

【0015】超音波診断装置により得られた超音波受信信号(アナログ信号)は、A/Dコンバータ1によりデジタル信号100に変換され、セレクタ22を介して図示しない表示装置に表示される。この際、A/Dコンバータ1によりデジタル信号に変換された超音波受信信号100はフレームメモリ2に記憶されている。

【0016】そして、表示装置に表示されている画像のうち濃淡差の小さい2つの領域をはっきりさせたい場合、オペレータは図示しない操作部により所望の領域を枠で囲む。すると、操作部からの入力信号はフレームメモリ読出し回路4へ入力され、フレームメモリ読出し回路4よりフレームメモリ2へ領域抽出信号101として出力される。それから、フレームメモリ2は領域抽出信号101により指定されるアドレスに従い1画面分のデータから枠で囲まれた注目画素を中心とした所定領域の現画像データXiを画素値強調回路3の減算器19へ出

力し、またセレクタ5を介してヒストグラム化回路7へ出力する。

【0017】更に、ヒストグラム化回路7は、枠に囲まれた注目画素を中心とした所定領域の現画像データXiに基づき図2に示すようなヒストグラムを作成する。そして、ヒストグラム化回路7により作成されたヒストグラムは、ヒストグラム平滑化回路11により平滑化される。例えば、前後8個ずつのデータを加算器13により加算することにより平滑化している。

10 【0018】それから、ヒストグラム化回路7により平滑化されたヒストグラムは、ピーク値検索回路15によりそのピーク値Pを検索される。すなわち、比較器16により前回のピーク値と今回のピーク値とを比較して今回のピーク値が大きい場合のみラッチ信号をラッチ17、18へ出力する。更に、ラッチ18より出力されるピーク値Pは減算器19に入力され、減算器19は、枠に囲まれた注目画素を中心とした所定領域の現画像データXiからピーク値Pを差し引き、差し引いた値Xi-Pを乗算器20へ出力する。

20 【0019】そして、乗算器20は、減算器19の出力Xi-Pにコントラスト強調定数Kを乗じて加算器21へ出力し、加算器21は、乗算器20の出力K(Xi-P)にピーク値検索回路15の出力Pを加算し、新たな濃淡値Yiを得る。それから、新たな濃淡値Yiにより枠に囲まれた注目画素を中心とした所定領域の画像を表示する。

【0020】例えば、K=2、P=100とした場合、図4に示すように、Xiが100より小さくなればなるほどYiはXiの値より小さくなり、Xiが100より大きくなればなるほどYiはXiの値より大きくなり、コントラストが上げられる。

【0021】

【発明の効果】以上説明したように、本発明によれば、ヒストグラム作成手段により画素情報における枠で囲んだ注目画素を中心とした所定領域内画素群のヒストグラムを作成し、ヒストグラム作成手段により作成されたヒストグラムのピーク値をピーク値検索手段により検索し、画素値強調手段により予め記憶した濃淡値表により枠で囲んだ注目画素を中心とした所定領域のみにコントラスト強調処理を行うように構成したので、リアルタイムに枠で囲んだ注目画素を中心とした所定領域に最適なコントラスト強調を行うことができる。

【図面の簡単な説明】

【図1】本発明に係る超音波画像処理装置の構成を示すブロック図である。

【図2】本発明に係るヒストグラム化回路により作成されたヒストグラムを示す図である。

【図3】本発明に係る画素値強調回路によりコントラスト強調処理を行ったヒストグラムを示す図である。

50 【図4】本発明の動作を説明するための図である。

【符号の説明】
 3 画像強調回路
 7 ヒストグラム化回路

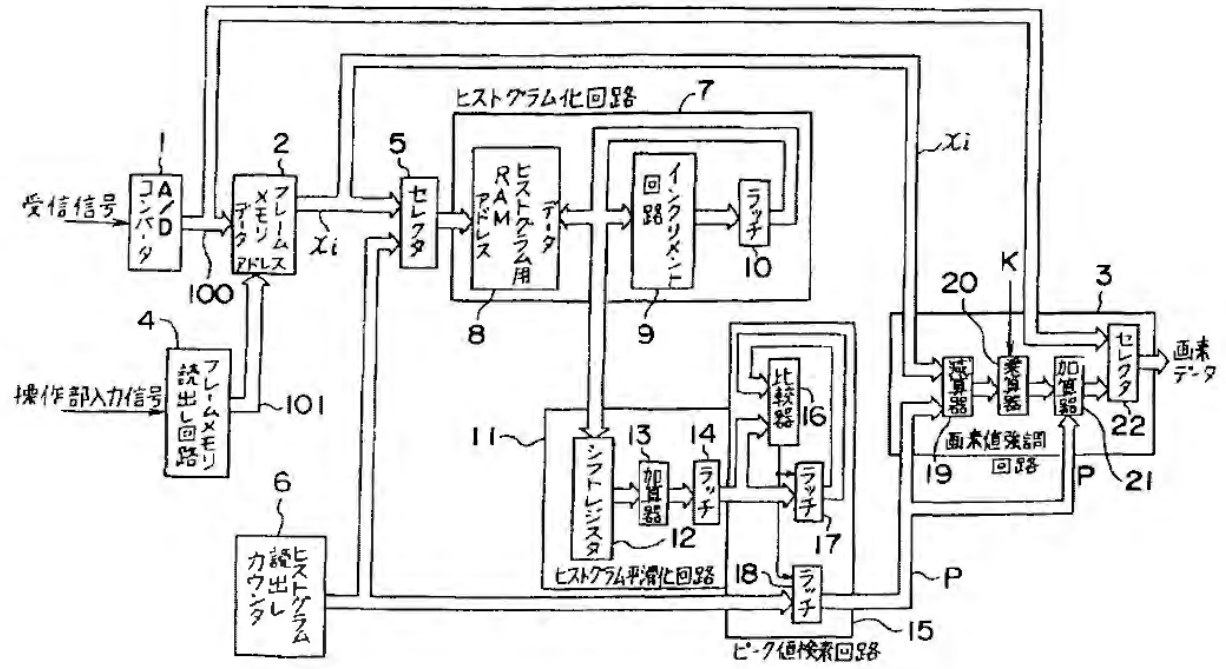

【図1】

(4)
 6
 11 ヒストグラム平滑化回路
 15 ピーク検素回路
 特開平6-205790

【図2】

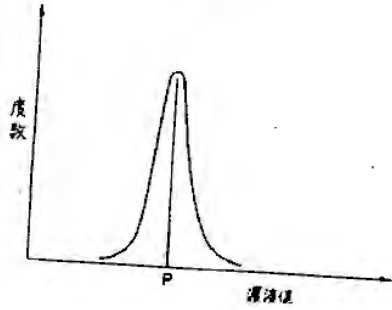

【図3】

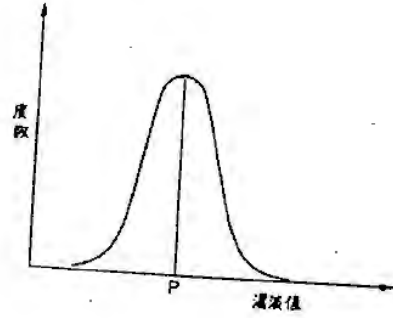

【図4】

X_i	Y_i
...	...
97	94
98	96
99	98
100	100
101	102
102	104
...	...

* NOTICES *

Japan Patent Office is not responsible for any damages caused by the use of this translation.

1. This document has been translated by computer. So the translation may not reflect the original precisely.
2. **** shows the word which can not be translated.
3. In the drawings, any words are not translated.

.....
DETAILED DESCRIPTION
.....

[Detailed Description of the Invention]

[0001]

[Industrial Application] This invention relates to the ultrasonic image processing system which can choose the range of the frame which is applied to the ultrasonic image processing system used for an ultrasonic diagnostic equipment, especially surrounds the predetermined field centering on the attention pixel in pixel information.

[0002]

[Description of the Prior Art] Although a bone is displayed white and an internal-organs organ is displayed on gray, and it is clearly displayed since the shade difference is large when the reflection factors of a supersonic wave differ among the obtained ultrasonic images in an ultrasonic diagnostic equipment conventionally like two fields where a shade difference is large, for example, a bone, and an internal-organs organ. For example, there is a function to change allocation of a gray scale bar as contrast adjustment or postprocess processing as a function of liver and the kidney to clarify two fields where a shade difference is small like.

[0003]

[Problem(s) to be Solved by the Invention] However, the function to change contrast adjustment and allocation of a gray scale bar is performed to the whole screen, and there is fault of giving the impression that image quality is hard. Moreover, in order to clarify two fields where level differs and where a shade difference is small in the ultrasonic image which will become remaining as it is once it sets up, and changes every moment, the function to change contrast adjustment and allocation of a gray scale bar had to be reset according to the level, and the time and effort was complicated.

[0004] This invention is made in order to cancel the above technical problems, it searches the degree of the contrast of the field to observe, and aims at offering the ultrasonic image processing system which can always perform contrast strengthening suitable for the field.

[0005]

[Means for Solving the Problem] The ultrasonic image processing system which this invention is made in view of the above-mentioned situation, and is applied to this invention. A histogram creation means to create the histogram of the pixel group in a predetermined field centering on the attention pixel in pixel information, A peak value retrieval means to search the peak value of the histogram created by the histogram creation means, It is characterized by performing contrast stretching only to the predetermined field which was equipped with a pixel value emphasis means by which the gray level table memorized beforehand performs contrast stretching processing only for an attention pixel, surrounded the predetermined field by the frame with the frame selection means, and was surrounded by the frame.

[0006]

[Function] Based on the above-mentioned configuration, the ultrasonic image processing system concerning this invention surround a predetermined field by the frame with a frame selection means, and the histogram of the pixel group in a predetermined field centering on the attention pixel in pixel information is created with a histogram creation means. The peak value of the histogram created by the histogram creation means is searched with a peak value retrieval means. Contrast stretching processing is performed only to the predetermined field centering on the attention pixel surrounded by the frame by the gray level table beforehand memorized with the pixel value emphasis means, and the optimal contrast stretching for the predetermined field centering on the attention pixel surrounded by the frame on real time can be performed.

[0007]

[Example] Hereafter, one example of this invention is explained using drawing.

[0008] Drawing 1 is the block diagram showing the configuration of the ultrasonic image processing system concerning this invention.

[0009] The ultrasonic image processing system has A/D converter 1 which carries out A/D conversion of the ultrasonic input signal (analog signal), and the frame memory 2 which memorizes the ultrasonic input signal 100 for one screen by which A/D conversion was carried out (digital signal), and the pixel value intensifier 3 mentioned later are connected to A/D converter 1. Furthermore, the ultrasonic image processing system has the frame memory read-out circuit 4 which inputs into a frame memory 2 the field extract signal 101 for extracting the predetermined field centering on the attention pixel surrounded by the frame with the input signal from a control unit (not shown), and a frame memory 2 outputs the data Xi of a predetermined field centering on an attention pixel according to the field extract signal (address) from the frame memory read-out circuit 4.

[0010] And the pixel value intensifier 3 and selector 5 which are mentioned later are connected to the frame memory 2, and a

selector 5 chooses the signal from a frame memory 2, or the signal from the histogram read-out counter 6. Furthermore, the histogram-ized circuit 7 which creates the histogram of the predetermined field centering on the attention pixel enclosed with a frame is connected to the selector 5, and the histogram-ized circuit 7 is constituted by RAMS for histograms, the increment circuit 9, and the latch 10.

[0011] Moreover, the histogram smoothing circuit 11 which graduates the created histogram is connected to the histogram-ized circuit 7, and the histogram smoothing circuit 11 is constituted by the shift register 12, the adder 13 which adds every eight data approximately, and the latch 14. And the histogram smoothing circuit 11 and the peak value retrieval circuit 15 which searches peak value P of the histogram graduated by the histogram smoothing circuit 11 to the histogram read-out counter 6 are connected, and the peak value retrieval circuit 15 is constituted by the comparator 16 which compares the last peak value with this peak value, and outputs a latch signal only when this peak value is large, and latches 17 and 18.

[0012] furthermore, to the peak value retrieval circuit 15, a frame memory 2, and A/D converter 1 The pixel value intensifier 3 which emphasizes the contrast of the predetermined field centering on the attention pixel enclosed with a frame is connected. The pixel value intensifier 3 The subtractor 19 which subtracts peak value P of the front image data searched by the peak value retrieval circuit 15 from the present image data Xi of the predetermined field centering on the attention pixel enclosed with a frame, The multiplier 20 which multiplies an output (Xi-P) by the contrast stretching constant K from a subtractor 19, It is constituted by the selector 22 which chooses the signal outputted from the adder 21 which adds peak value P to the output K of a multiplier 20 (Xi-P), and the signal or adder 21 from A/D converter 1.

[0013] In addition, since it becomes Gaussian distribution as a histogram is shown in drawing 2, and this Gaussian distribution will become narrow if Gaussian distribution lowers breadth and contrast if contrast is raised, this description is applied, and contrast can be raised, if the configuration of the present histogram as shown in drawing 2 is changed so that it may spread focusing on peak value as shown in drawing 3. That is, a gray level table which spreads the configuration of a histogram focusing on peak value is created, and contrast can be raised if regeneration of the image is carried out. If P and the gray level of each present pixel are set to Xi for the gray level which takes peak value when a histogram as shown in drawing 2 is obtained, the new gray level Yi will be calculated by the degree Yi.

[0014] $Y_i = K(X_i - P) + P$, next an operation of this example are explained.

[0015] The ultrasonic input signal (analog signal) obtained by the ultrasonic diagnostic equipment is changed into a digital signal 100 by A/D converter 1, and is displayed on the display which is not illustrated through a selector 22. Under the present circumstances, the ultrasonic input signal 100 changed into the digital signal by A/D converter 1 is memorized by the frame memory 2.

[0016] And when two fields where a shade difference is small want to clarify among the images currently displayed on the display, an operator surrounds a desired field by the frame by the control unit which is not illustrated. Then, the input signal from a control unit is inputted into the frame memory read-out circuit 4, and is outputted to a frame memory 2 as a field extract signal 101 from the frame memory read-out circuit 4. And a frame memory 2 outputs the present image data Xi of the predetermined field centering on the attention pixel surrounded by the frame from the data for one screen according to the address specified by the field extract signal 101 to the subtractor 19 of the pixel value intensifier 3, and outputs it to the histogram-ized circuit 7 through a selector 5.

[0017] Furthermore, the histogram-ized circuit 7 creates a histogram as shown in drawing 2 based on the present image data Xi of the predetermined field centering on the attention pixel surrounded by the frame. And the histogram created by the histogram-ized circuit 7 is graduated by the histogram smoothing circuit 11. For example, it has graduated by adding every eight data with an adder 13 approximately.

[0018] And the histogram graduated by the histogram-ized circuit 7 has the peak value P searched by the peak value retrieval circuit 15. That is, a comparator 16 compares the last peak value and this peak value, and only when this peak value is large, a latch signal is outputted to latches 17 and 18. Furthermore, peak value P outputted by latch 18 is inputted into a subtractor 19, and from the present image data Xi of the predetermined field centering on the attention pixel surrounded by the frame, a subtractor 19 deducts peak value P and outputs deducted value Xi-P to a multiplier 20.

[0019] And a multiplier 20 multiplies output Xi-P of a subtractor 19 by the contrast stretching constant K, and outputs it to an adder 21, and an adder 21 adds the output P of the peak value retrieval circuit 15 to the output K of a multiplier 20 (Xi-P), and obtains the new gray level Yi. And the image of the predetermined field centering on the attention pixel surrounded by the frame with the new gray level Yi is displayed.

[0020] For example, the more Xi becomes smaller than 100, it becomes smaller [Yi] than the value of Xi and Xi becomes larger than 100, it becomes larger [Yi] than the value of Xi, and, the more contrast is raised [when referred to as $K=2$ and $P=100$, as it is shown in drawing 4,].

[0021]

[Effect of the Invention] As explained above, according to this invention, the histogram of the pixel group in a predetermined field centering on the attention pixel surrounded by the frame in pixel information with the histogram creation means is created. The peak value of the histogram created by the histogram creation means is searched with a peak value retrieval means. Since it constituted so that contrast stretching processing might be performed only to the predetermined field centering on the attention pixel surrounded by the frame by the gray level table beforehand memorized with the pixel value emphasis means, the optimal contrast stretching for the predetermined field centering on the attention pixel surrounded by the frame on real time can be performed.

[Translation done.]

THIS PAGE BLANK (USPTO)

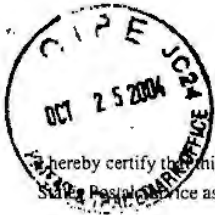

I hereby certify that this correspondence is being deposited with the United States Postal Service as first class mail in an envelope addressed to:

Commissioner for Patents
P.O. Box 1450
Alexandria, VA 22313-1450

On October 22, 2004

TOWNSEND and TOWNSEND and CREW LLP

By: Sylvia E. Arnold
Sylvia E. Arnold

PATENT
Attorney Docket No.: 20046H-000100US
Client Ref. No.: 308L US 3772

IN THE UNITED STATES PATENT AND TRADEMARK OFFICE

In re application of:

Patrick Pirim

Application No.: 09/792,436

Filed: February 23, 2001

For: METHOD AND DEVICE FOR
AUTOMATIC VISUAL PERCEPTION

Customer No.: 20350

Confirmation No. 9956

Examiner: George B. Davis

Technology Center/Art Unit: 2121

COMMUNICATION

Commissioner for Patents
P.O. Box 1450
Alexandria, VA 22313-1450

Sir:

In response to the Notice of Allowability mailed October 6, 2004, Applicants respectfully request issuance of a revised or supplemental Notice for the reasons as discussed herein in the Remarks section.

Remarks/Arguments begin on page 2 of this paper.

REMARKS/ARGUMENTS

A copy of the Notice of Allowability mailed October 6, 2004 is enclosed. In that Notice item 4 indicates that none of the certified copies of the priority documents have been received. The undersigned, however, respectfully asserts that a certified copy of the priority document was filed on August 26, 2004, and was indeed received by the Patent Office as evidenced by its availability through the PAIR website. Correction of this acknowledgement is respectfully requested.

Additionally, item 7 in the Notice indicates that the deposit of biological material is required. It is respectfully assumed that this requirement is erroneous because this application has nothing to do with biological material. Correction of this requirement is also respectfully requested.

Therefore, it is respectfully requested that a revised or supplemental Notice of Allowability be issued, and that the date for payment of the Issue Fee be reset accordingly.

CONCLUSION

In view of the foregoing, the issuance of a revised or supplemental Notice of Allowance at an early date is respectfully requested.

If the Examiner believes a telephone conference would expedite prosecution of this application, please telephone the undersigned at 925-472-5000.

Respectfully submitted,

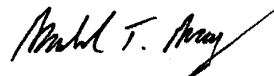

Gerald T. Gray
Reg. No. 41,797

TOWNSEND and TOWNSEND and CREW LLP
Two Embarcadero Center, Eighth Floor
San Francisco, California 94111-3834
Tel: 925-472-5000
Fax: 415-576-0300
Attachments
GTG:sea
60336930 v1



UNITED STATES PATENT AND TRADEMARK OFFICE

20046H-001005

DATA, NC

UNITED STATES DEPARTMENT OF COMMERCE
United States Patent and Trademark Office
Address: COMMISSIONER FOR PATENTS
P.O. Box 1450
Alexandria, Virginia 22313-1450
www.uspto.gov

NOTICE OF ALLOWANCE AND FEE(S) DUE

20350 7590 10/06/2004
TOWNSEND AND TOWNSEND AND CREW, LLP
TWO EMBARCADERO CENTER
EIGHTH FLOOR
SAN FRANCISCO, CA 94111-3834

EXAMINER

DAVIS, GEORGE B

ART UNIT PAPER NUMBER

2121

DATE MAILED: 10/06/2004

Issue Fee Due
(Corrected Amounts)

1/6/05

APPLICATION NO.	EXPIRING DATE	FIRST NAMED INVENTOR	ATTORNEY DOCKET NO.	CONFIRMATION NO.
09/792,436	02/23/2001	Patrick Pirim	20046H-000100	9956

TITLE OF INVENTION: METHOD AND DEVICE FOR AUTOMATIC VISUAL PERCEPTION

APPLN. TYPE	SMALL ENTITY	ISSUE FEE	PUBLICATION FEE	TOTAL FEE(S) DUE	DATE DUE
nonprovisional	NO	\$1370	\$300	\$1670	01/06/2005

THE APPLICATION IDENTIFIED ABOVE HAS BEEN EXAMINED AND IS ALLOWED FOR ISSUANCE AS A PATENT. **PROSECUTION ON THE MERITS IS CLOSED.** THIS NOTICE OF ALLOWANCE IS NOT A GRANT OF PATENT RIGHTS. THIS APPLICATION IS SUBJECT TO WITHDRAWAL FROM ISSUE AT THE INITIATIVE OF THE OFFICE OR UPON PETITION BY THE APPLICANT. SEE 37 CFR 1.313 AND MPEP 1308.

THE ISSUE FEE AND PUBLICATION FEE (IF REQUIRED) MUST BE PAID WITHIN THREE MONTHS FROM THE MAILING DATE OF THIS NOTICE OR THIS APPLICATION SHALL BE REGARDED AS ABANDONED. **THIS STATUTORY PERIOD CANNOT BE EXTENDED.** SEE 35 U.S.C. 151. THE ISSUE FEE DUE INDICATED ABOVE REFLECTS A CREDIT FOR ANY PREVIOUSLY PAID ISSUE FEE APPLIED IN THIS APPLICATION. THE PTOL-85B (OR AN EQUIVALENT) MUST BE RETURNED WITHIN THIS PERIOD EVEN IF NO FEE IS DUE OR THE APPLICATION WILL BE REGARDED AS ABANDONED.

HOW TO REPLY TO THIS NOTICE:

- I. Review the SMALL ENTITY status shown above.
- If the SMALL ENTITY is shown as YES, verify your current SMALL ENTITY status:
- A. If the status is the same, pay the TOTAL FEE(S) DUE shown above.
 - B. If the status above is to be removed, check box 5b on Part B - Fee(s) Transmittal and pay the PUBLICATION FEE (if required) and twice the amount of the ISSUE FEE shown above, or

- If the SMALL ENTITY is shown as NO:
- A. Pay TOTAL FEE(S) DUE shown above, or
 - B. If applicant claimed SMALL ENTITY status before, or is now claiming SMALL ENTITY status, check box 5a on Part B - Fee(s) Transmittal and pay the PUBLICATION FEE (if required) and 1/2 the ISSUE FEE shown above.

II. PART B - FEE(S) TRANSMITTAL should be completed and returned to the United States Patent and Trademark Office (USPTO) with your ISSUE FEE and PUBLICATION FEE (if required). Even if the fee(s) have already been paid, Part B - Fee(s) Transmittal should be completed and returned. If you are charging the fee(s) to your deposit account, section "4b" of Part B - Fee(s) Transmittal should be completed and an extra copy of the form should be submitted.

III. All communications regarding this application must give the application number. Please direct all communications prior to issuance to Mail Stop ISSUE FEE unless advised to the contrary.

IMPORTANT REMINDER: Utility patents issuing on applications filed on or after Dec. 12, 1980 may require payment of maintenance fees. It is patentee's responsibility to ensure timely payment of maintenance fees when due.

THE S



PART B - FEE(S) TRANSMITTAL

Complete and send this form, together with applicable fee(s), to: Mail Stop ISSUE FEE Commissioner for Patents P.O. Box 1450 Alexandria, Virginia 22313-1450 or Fax (703) 746-4000

INSTRUCTIONS: This form should be used for transmitting the ISSUE FEE and PUBLICATION FEE (if required). Blocks 1 through 5 should be completed where appropriate. All further correspondence including the Patent, advance orders and notification of maintenance fees will be mailed to the current correspondence address as indicated unless corrected below or directed otherwise in Block 1, by (a) specifying a new correspondence address; and/or (b) indicating a separate "FEE ADDRESS" for maintenance fee notifications.

CURRENT CORRESPONDENCE ADDRESS (Note: Use Block 1 for any change of address)

20350 7590 10/06/2004 TOWNSEND AND TOWNSEND AND CREW, LLP TWO EMBARCADERO CENTER EIGHTH FLOOR SAN FRANCISCO, CA 94111-3834

Note: A certificate of mailing can only be used for domestic mailings of the Fee(s) Transmittal. This certificate cannot be used for any other accompanying papers. Each additional paper, such as an assignment or formal drawing, must have its own certificate of mailing or transmission.

Certificate of Mailing or Transmission I hereby certify that this Fee(s) Transmittal is being deposited with the United States Postal Service with sufficient postage for first class mail in an envelope addressed to the Mail Stop ISSUE FEE address above, or being facsimile transmitted to the USPTO (703) 746-4000, on the date indicated below.

Form with fields for Depositor's name, Signature, and Date.

Table with 5 columns: APPLICATION NO., FILING DATE, FIRST NAMED INVENTOR, ATTORNEY DOCKET NO., CONFIRMATION NO. Values: 09/792,436, 02/23/2001, Patrick Pirin, 20046H-000100, 9956

TITLE OF INVENTION: METHOD AND DEVICE FOR AUTOMATIC VISUAL PERCEPTION

Table with 6 columns: APPLN. TYPE, SMALL ENTITY, ISSUE FEE, PUBLICATION FEE, TOTAL FEE(S) DUE, DATE DUE. Values: nonprovisional, NO, \$1370, \$300, \$1670, 01/06/2005

Table with 3 columns: EXAMINER, ART UNIT, CLASS-SUBCLASS. Values: DAVIS, GEORGE B, 2121, 706-020000

Form with 2 main sections: 1. Change of correspondence address or indication of "Fee Address" (37 CFR 1.363). 2. For printing on the patent front page, list (1) the names of up to 3 registered patent attorneys or agents OR, alternatively, (2) the name of a single firm (having as a member a registered attorney or agent) and the names of up to 2 registered patent attorneys or agents. If no name is listed, no name will be printed.

3. ASSIGNEE NAME AND RESIDENCE DATA TO BE PRINTED ON THE PATENT (print or type) PLEASE NOTE: Unless an assignee is identified below, no assignee data will appear on the patent. If an assignee is identified below, the document has been filed for recordation as set forth in 37 CFR 3.11. Completion of this form is NOT a substitute for filing an assignment.

(A) NAME OF ASSIGNEE (B) RESIDENCE: (CITY and STATE OR COUNTRY)

Please check the appropriate assignee category or categories (will not be printed on the patent): Individual Corporation or other private group entity Government

Form with 4a. The following fee(s) are enclosed: Issue Fee, Publication Fee, Advance Order. 4b. Payment of Fee(s): A check in the amount of the fee(s) is enclosed, Payment by credit card, The Director is hereby authorized by charge the required fee(s), or credit any overpayment, to Deposit Account Number.

5. Change in Entity Status (from status indicated above) a. Applicant claims SMALL ENTITY status. See 37 CFR 1.27. b. Applicant is no longer claiming SMALL ENTITY status. See 37 CFR 1.27(e)(2).

The Director of the USPTO is requested to apply the Issue Fee and Publication Fee (if any) or to re-apply any previously paid issue fee to the application identified above. NOTE: The Issue Fee and Publication Fee (if required) will not be accepted from anyone other than the applicant; a registered attorney or agent; or the assignee or other party in interest as shown by the records of the United States Patent and Trademark Office.

Authorized Signature, Date, Typed or printed name, Registration No.

This collection of information is required by 37 CFR 1.311. The information is required to obtain or retain a benefit by the public which is to file (and by the USPTO to process) an application. Confidentiality is governed by 35 U.S.C. 122 and 37 CFR 1.14. This collection is estimated to take 12 minutes to complete, including gathering, preparing, and submitting the completed application form to the USPTO. Time will vary depending upon the individual case. Any comments on the amount of time you require to complete this form and/or suggestions for reducing this burden, should be sent to the Chief Information Officer, U.S. Patent and Trademark Office, U.S. Department of Commerce, P.O. Box 1450, Alexandria, Virginia 22313-1450. DO NOT SEND FEES OR COMPLETED FORMS TO THIS ADDRESS. SEND TO: Commissioner for Patents, P.O. Box 1450, Alexandria, Virginia 22313-1450.

Under the Paperwork Reduction Act of 1995, no persons are required to respond to a collection of information unless it displays a valid OMB control number.



UNITED STATES PATENT AND TRADEMARK OFFICE

UNITED STATES DEPARTMENT OF COMMERCE
United States Patent and Trademark Office
Address: COMMISSIONER FOR PATENTS
P.O. Box 1450
Alexandria, Virginia 22313-1450
www.uspto.gov

APPLICATION NO.	FILING DATE	FIRST NAMED INVENTOR	ATTORNEY DOCKET NO.	CONFIRMATION NO.
09/792,436	02/23/2001	Patrick Pirm	20046H-000100	9956

20350 7590 10/06/2004
TOWNSEND AND TOWNSEND AND CREW, LLP
TWO EMBARCADERO CENTER
EIGHTH FLOOR
SAN FRANCISCO, CA 94111-3834

EXAMINER

DAVIS, GEORGE B

ART UNIT PAPER NUMBER

2121

DATE MAILED: 10/06/2004

Determination of Patent Term Adjustment under 35 U.S.C. 154 (b)
(application filed on or after May 29, 2000)

The Patent Term Adjustment to date is 335 day(s). If the issue fee is paid on the date that is three months after the mailing date of this notice and the patent issues on the Tuesday before the date that is 28 weeks (six and a half months) after the mailing date of this notice, the Patent Term Adjustment will be 335 day(s).

If a Continued Prosecution Application (CPA) was filed in the above-identified application, the filing date that determines Patent Term Adjustment is the filing date of the most recent CPA.

Applicant will be able to obtain more detailed information by accessing the Patent Application Information Retrieval (PAIR) WEB site (<http://pair.uspto.gov>).

Any questions regarding the Patent Term Extension or Adjustment determination should be directed to the Office of Patent Legal Administration at (703) 305-1383. Questions relating to issue and publication fee payments should be directed to the Customer Service Center of the Office of Patent Publication at (703) 305-8283.



UNITED STATES PATENT AND TRADEMARK OFFICE

UNITED STATES DEPARTMENT OF COMMERCE
United States Patent and Trademark Office
Address: COMMISSIONER FOR PATENTS
P.O. Box 1450
Alexandria, Virginia 22315-1450
www.uspto.gov

APPLICATION NO.	FILING DATE	FIRST NAMED INVENTOR	ATTORNEY DOCKET NO.	CONFIRMATION NO.
09/792,436	02/23/2001	Patrick Pirim	20046H-000100	9956

20350 7590 10/06/2004
TOWNSEND AND TOWNSEND AND CREW, LLP
TWO EMBARCADERO CENTER
EIGHTH FLOOR
SAN FRANCISCO, CA 94111-3834

EXAMINER

DAVIS, GEORGE B

ART UNIT PAPER NUMBER

2121

DATE MAILED: 10/06/2004

Notice of Fee Increase on October 1, 2004

If a reply to a "Notice of Allowance and Fee(s) Due" is filed in the Office on or after October 1, 2004, then the amount due will be higher than that set forth in the "Notice of Allowance and Fee(s) Due" because some fees will increase effective October 1, 2004. See Revision of Patent Fees for Fiscal Year 2005; Final Rule, 69 Fed. Reg. 52604, 52606 (May 10, 2004).

The current fee schedule is accessible from WEB site (<http://www.uspto.gov/main/howtofees.htm>).

If the fee paid is the amount shown on the "Notice of Allowance and Fee(s) Due" but not the correct amount in view of the fee increase, a "Notice of Pay Balance of Issue Fee" will be mailed to applicant. In order to avoid processing delays associated with mailing of a "Notice of Pay Balance of Issue Fee," if the response to the Notice of Allowance is to be filed on or after October 1, 2004 (or mailed with a certificate of mailing on or after October 1, 2004), the issue fee paid should be the fee that is required at the time the fee is paid. See Manual of Patent Examining Procedure (MPEP), Section 1306 (Eighth Edition, Rev. 2, May 2004). If the issue fee was previously paid, and the response to the "Notice of Allowance and Fee(s) Due" includes a request to apply a previously-paid issue fee to the issue fee now due, then the difference between the issue fee amount at the time the response is filed and the previously-paid issue fee should be paid. See MPEP Section 1308.01.

Effective October 1, 2004, 37 CFR 1.18 is amended by revising paragraphs (a) through (c) to read as set forth below.

Section 1.18 Patent post allowance (including issue) fees.

- (a) Issue fee for issuing each original or reissue patent, except a design or plant patent:
 - By a small entity (Sec. 1.27(a))..... \$685.00
 - By other than a small entity..... \$1,370.00
- (b) Issue fee for issuing a design patent:
 - By a small entity (Sec. 1.27(a))..... \$245.00
 - By other than a small entity..... \$490.00
- (c) Issue fee for issuing a plant patent:
 - By a small entity (Sec. 1.27(a))..... \$330.00
 - By other than a small entity..... \$660.00

Questions relating to issue and publication fee payments should be directed to the Customer Service Center of the Office of Patent Publication at (703) 305-8283.



Notice of Allowability

Application No. 09/792,436	Applicant(s) PIRIM, PATRICK
Examiner George Davis	Art Unit 2121

- The MAILING DATE of this communication appears on the cover sheet with the correspondence address-
 All claims being allowable, PROSECUTION ON THE MERITS IS (OR REMAINS) CLOSED in this application. If not included herewith (or previously mailed), a Notice of Allowance (PTOL-85) or other appropriate communication will be mailed in due course. **THIS NOTICE OF ALLOWABILITY IS NOT A GRANT OF PATENT RIGHTS.** This application is subject to withdrawal from issue at the initiative of the Office or upon petition by the applicant. See 37 CFR 1.313 and MPEP 1308.

1. This communication is responsive to 8/30/2004.
2. The allowed claim(s) is/are 1-29.
3. The drawings filed on _____ are accepted by the Examiner.
4. Acknowledgment is made of a claim for foreign priority under 35 U.S.C. § 119(a)-(d) or (f).
 - a) All b) Some* c) None of the:
 1. Certified copies of the priority documents have been received.
 2. Certified copies of the priority documents have been received in Application No. _____.
 3. Copies of the certified copies of the priority documents have been received in this national stage application from the International Bureau (PCT Rule 17.2(a)).

* Certified copies not received: _____

Applicant has **THREE MONTHS FROM THE "MAILING DATE"** of this communication to file a reply complying with the requirements noted below. Failure to timely comply will result in **ABANDONMENT** of this application.
THIS THREE-MONTH PERIOD IS NOT EXTENDABLE.

5. A SUBSTITUTE OATH OR DECLARATION must be submitted. Note the attached EXAMINER'S AMENDMENT or NOTICE OF INFORMAL PATENT APPLICATION (PTO-152) which gives reason(s) why the oath or declaration is deficient.
 6. CORRECTED DRAWINGS (as "replacement sheets") must be submitted.
 - (a) including changes required by the Notice of Draftsperson's Patent Drawing Review (PTO-948) attached
 - 1) hereto or 2) to Paper No./Mail Date _____.
 - (b) including changes required by the attached Examiner's Amendment / Comment or in the Office action of Paper No./Mail Date 3/26/2004.
- Identifying indicia such as the application number (see 37 CFR 1.84(c)) should be written on the drawings in the front (not the back) of each sheet. Replacement sheet(s) should be labeled as such in the header according to 37 CFR 1.121(d).
7. DEPOSIT OF and/or INFORMATION about the deposit of BIOLOGICAL MATERIAL must be submitted. Note the attached Examiner's comment regarding REQUIREMENT FOR THE DEPOSIT OF BIOLOGICAL MATERIAL.

Attachment(s)

- | | |
|---|---|
| 1. <input type="checkbox"/> Notice of References Cited (PTO-892) | 5. <input type="checkbox"/> Notice of Informal Patent Application (PTO-152) |
| 2. <input type="checkbox"/> Notice of Draftsperson's Patent Drawing Review (PTO-948) | 6. <input type="checkbox"/> Interview Summary (PTO-413),
Paper No./Mail Date _____ |
| 3. <input checked="" type="checkbox"/> Information Disclosure Statements (PTO-1449 or PTO/SB/08),
Paper No./Mail Date <u>6/22/2004</u> | 7. <input type="checkbox"/> Examiner's Amendment/Comment |
| 4. <input type="checkbox"/> Examiner's Comment Regarding Requirement for Deposit
of Biological Material | 8. <input type="checkbox"/> Examiner's Statement of Reasons for Allowance |
| | 9. <input type="checkbox"/> Other _____ |

George Davis
 Primary Examiner
 Art Unit: 2121



Substitute for form 1448A/PTO

INFORMATION DISCLOSURE STATEMENT BY APPLICANT
(Use as many sheets as necessary)

Complete if Known	
Application Number	08/792,438
Filing Date	February 23, 2001
First Named Inventor	Firm, Patrick
Art Unit	2121
Examiner Name	Davis, George B.
Attorney Docket Number	20048H-000100US

Sheet 1 of 1

U.S. PATENT DOCUMENTS					
Examiner	Cite No. ¹	Document Number	Publication Date MM-DD-YYYY	Name of Patentee or Applicant of Cited Document	Pages, Columns, Lines, Where Relevant Passages or Relevant Figures Appear
		Number Kind Code ² (if known)			class / subclass
<i>G.D.</i>	1	US-5,008,948	04-16-1991	Ando	382 / 104
<i>G.D.</i>	2	US-5,625,717	04-29-1997	Hashimoto et al.	382 / 260
					RECEIVED
					JUN 28 2004
					Technology Center 2100

FOREIGN PATENT DOCUMENTS								
Examiner Initials ¹	Cite No. ¹	Foreign Patent Document			Publication Date MM-DD-YYYY	Name of Patentee or Applicant of Cited Document	Pages, Columns, Lines, Where Relevant Passages or Relevant Figures Appear	T ²
		Country Code ³	Number ⁴	Kind Code ⁵ (if known)				
								<input type="checkbox"/>
								<input type="checkbox"/>
								<input type="checkbox"/>
								<input type="checkbox"/>
								<input type="checkbox"/>
								<input type="checkbox"/>
								<input type="checkbox"/>
								<input type="checkbox"/>

Examiner Signature	<i>George Davis</i>	Date Considered	<i>9/30/04</i>
--------------------	---------------------	-----------------	----------------

¹ EXAMINER: Initial if reference considered, whether or not citation is in conformance with MPEP 609. Draw line through citation if not in conformance and not considered. Include copy of this form with next communication to applicant. ² Applicant's unique citation designation number (optional). ³ See Kind Codes of USPTO Patent Documents at www.uspto.gov or MPEP 901.04. ⁴ Enter Office that issued the document, by the two-letter code (WIPO Standard ST.3). ⁵ For Japanese patent documents, the indication of the year of the reign of the Emperor must precede the serial number of the patent document. ⁶ Kind of document by the appropriate symbols as indicated on the document under WIPO Standard ST. 16 if possible. ⁷ Applicant is to place a check mark here if English language translation is attached.



921 921
 10012
 PTO/SS/21 (04-04)

PATENT TRANSMITTAL FORM <small>(to be used for all correspondence after initial filing)</small>	Application Number	09/792,436
	Filing Date	February 23, 2001
	First Named Inventor	Pirim, Patrick
	Art Unit	2121
	Examiner Name	George B. Davis
	Attorney Docket Number	20046H-000100US
Total Number of Pages in This Submission		

ENCLOSURES (Check all that apply)		
<input type="checkbox"/> Fee Transmittal Form	<input type="checkbox"/> Drawing(s)	<input type="checkbox"/> After Allowance Communication to Technology Center (TC)
<input type="checkbox"/> Fee Attached	<input type="checkbox"/> Licensing-related Papers	<input type="checkbox"/> Appeal Communication to Board of Appeals and Interferences
<input type="checkbox"/> Amendment/Reply	<input type="checkbox"/> Petition	<input type="checkbox"/> Appeal Communication to TC (Appeal Notice, Brief, Reply Brief)
<input type="checkbox"/> After Final	<input type="checkbox"/> Petition to Convert to a Provisional Application	<input type="checkbox"/> Proprietary Information
<input type="checkbox"/> Affidavits/declaration(s)	<input type="checkbox"/> Power of Attorney, Revocation Change of Correspondence Address	<input type="checkbox"/> Status Letter
<input type="checkbox"/> Extension of Time Request	<input type="checkbox"/> Terminal Disclaimer	<input checked="" type="checkbox"/> Other Enclosure(s) (please identify below):
<input type="checkbox"/> Express Abandonment Request	<input type="checkbox"/> Request for Refund	Return Postcard Communication
<input type="checkbox"/> Information Disclosure Statement	<input type="checkbox"/> CD, Number of CD(s)	
<input type="checkbox"/> Certified Copy of Priority Document(s)	Remarks: The Commissioner is authorized to charge any additional fees to Deposit Account 20-1430.	
<input type="checkbox"/> Response to Missing Parts/ Incomplete Application		
<input type="checkbox"/> Response to Missing Parts under 37 CFR 1.52 or 1.53		

SIGNATURE OF APPLICANT, ATTORNEY, OR AGENT	
Firm or Individual name	Townsend and Townsend and Crew LLP Gerald T. Gray Reg. No. 44,797
Signature	<i>Gerald T. Gray</i>
Date	October 22, 2004

CERTIFICATE OF TRANSMISSION/MAILING	
I hereby certify that this correspondence is being deposited with the United States Postal Service with sufficient postage as first class mail in an envelope addressed to: Commissioner for Patents, P.O. Box 1450, Alexandria, VA 22313-1450 on the date shown below.	
Typed or printed name	Sylvia E. Arnold
Signature	<i>Sylvia E. Arnold</i>
Date	October 22, 2004

2



UNITED STATES PATENT AND TRADEMARK OFFICE

UNITED STATES DEPARTMENT OF COMMERCE
United States Patent and Trademark Office
Address: COMMISSIONER FOR PATENTS
P.O. Box 1450
Alexandria, Virginia 22313-1450
www.uspto.gov

NOTICE OF ALLOWANCE AND FEE(S) DUE

20350 7590 10/06/2004
TOWNSEND AND TOWNSEND AND CREW, LLP
TWO EMBARCADERO CENTER
EIGHTH FLOOR
SAN FRANCISCO, CA 94111-3834

EXAMINER
DAVIS, GEORGE B

ART UNIT PAPER NUMBER
2121

DATE MAILED: 10/06/2004

Table with 5 columns: APPLICATION NO., FILING DATE, FIRST NAMED INVENTOR, ATTORNEY DOCKET NO., CONFIRMATION NO.
Values: 09/792,436, 02/23/2001, Patrick Pirim, 20046H-000100, 9956

TITLE OF INVENTION: METHOD AND DEVICE FOR AUTOMATIC VISUAL PERCEPTION

Table with 6 columns: APPLN. TYPE, SMALL ENTITY, ISSUE FEE, PUBLICATION FEE, TOTAL FEE(S) DUE, DATE DUE
Values: nonprovisional, NO, \$1370, \$300, \$1670, 01/06/2005

THE APPLICATION IDENTIFIED ABOVE HAS BEEN EXAMINED AND IS ALLOWED FOR ISSUANCE AS A PATENT. PROSECUTION ON THE MERITS IS CLOSED. THIS NOTICE OF ALLOWANCE IS NOT A GRANT OF PATENT RIGHTS. THIS APPLICATION IS SUBJECT TO WITHDRAWAL FROM ISSUE AT THE INITIATIVE OF THE OFFICE OR UPON PETITION BY THE APPLICANT. SEE 37 CFR 1.313 AND MPEP 1308.

THE ISSUE FEE AND PUBLICATION FEE (IF REQUIRED) MUST BE PAID WITHIN THREE MONTHS FROM THE MAILING DATE OF THIS NOTICE OR THIS APPLICATION SHALL BE REGARDED AS ABANDONED. THIS STATUTORY PERIOD CANNOT BE EXTENDED. SEE 35 U.S.C. 151. THE ISSUE FEE DUE INDICATED ABOVE REFLECTS A CREDIT FOR ANY PREVIOUSLY PAID ISSUE FEE APPLIED IN THIS APPLICATION. THE PTOL-85B (OR AN EQUIVALENT) MUST BE RETURNED WITHIN THIS PERIOD EVEN IF NO FEE IS DUE OR THE APPLICATION WILL BE REGARDED AS ABANDONED.

HOW TO REPLY TO THIS NOTICE:

I. Review the SMALL ENTITY status shown above.

If the SMALL ENTITY is shown as YES, verify your current SMALL ENTITY status:

A. If the status is the same, pay the TOTAL FEE(S) DUE shown above.

B. If the status above is to be removed, check box 5b on Part B - Fee(s) Transmittal and pay the PUBLICATION FEE (if required) and twice the amount of the ISSUE FEE shown above, or

If the SMALL ENTITY is shown as NO:

A. Pay TOTAL FEE(S) DUE shown above, or

B. If applicant claimed SMALL ENTITY status before, or is now claiming SMALL ENTITY status, check box 5a on Part B - Fee(s) Transmittal and pay the PUBLICATION FEE (if required) and 1/2 the ISSUE FEE shown above.

II. PART B - FEE(S) TRANSMITTAL should be completed and returned to the United States Patent and Trademark Office (USPTO) with your ISSUE FEE and PUBLICATION FEE (if required). Even if the fee(s) have already been paid, Part B - Fee(s) Transmittal should be completed and returned. If you are charging the fee(s) to your deposit account, section "4b" of Part B - Fee(s) Transmittal should be completed and an extra copy of the form should be submitted.

III. All communications regarding this application must give the application number. Please direct all communications prior to issuance to Mail Stop ISSUE FEE unless advised to the contrary.

IMPORTANT REMINDER: Utility patents issuing on applications filed on or after Dec. 12, 1980 may require payment of maintenance fees. It is patentee's responsibility to ensure timely payment of maintenance fees when due.

Handwritten mark

PART B - FEE(S) TRANSMITTAL

Complete and send this form, together with applicable fee(s), to: **Mail** Mail Stop ISSUE FEE
Commissioner for Patents
P.O. Box 1450
Alexandria, Virginia 22313-1450
or Fax (703) 746-4000

INSTRUCTIONS: This form should be used for transmitting the ISSUE FEE and PUBLICATION FEE (if required). Blocks 1 through 5 should be completed where appropriate. All further correspondence including the Patent, advance orders and notification of maintenance fees will be mailed to the current correspondence address as indicated unless corrected below or directed otherwise in Block 1, by (a) specifying a new correspondence address; and/or (b) indicating a separate "FEE ADDRESS" for maintenance fee notifications.

CURRENT CORRESPONDENCE ADDRESS (Note: Use Block 1 for any change of address)

20350 7590 10/06/2004
TOWNSEND AND TOWNSEND AND CREW, LLP
TWO EMBARCADERO CENTER
EIGHTH FLOOR
SAN FRANCISCO, CA 94111-3834

Note: A certificate of mailing can only be used for domestic mailings of the Fee(s) Transmittal. This certificate cannot be used for any other accompanying papers. Each additional paper, such as an assignment or formal drawing, must have its own certificate of mailing or transmission.

Certificate of Mailing or Transmission
 I hereby certify that this Fee(s) Transmittal is being deposited with the United States Postal Service with sufficient postage for first class mail in an envelope addressed to the Mail Stop ISSUE FEE address above, or being facsimile transmitted to the USPTO (703) 746-4000, on the date indicated below.

(Depositor's name)
(Signature)
(Date)

APPLICATION NO.	FILING DATE	FIRST NAMED INVENTOR	ATTORNEY DOCKET NO.	CONFIRMATION NO.
09/792,436	02/23/2001	Patrick Pirim	20046H-000100	9956

TITLE OF INVENTION: METHOD AND DEVICE FOR AUTOMATIC VISUAL PERCEPTION

APPLN. TYPE	SMALL ENTITY	ISSUE FEE	PUBLICATION FEE	TOTAL FEE(S) DUE	DATE DUE
nonprovisional	NO	\$1370	\$300	\$1670	01/06/2005

EXAMINER	ART UNIT	CLASS-SUBCLASS
DAVIS, GEORGE B	2121	706-020000

1. Change of correspondence address or indication of "Fee Address" (37 CFR 1.363).
 Change of correspondence address (or Change of Correspondence Address form PTO/SB/122) attached.
 "Fee Address" indication (or "Fee Address" Indication form PTO/SB/47; Rev 03-02 or more recent) attached. Use of a Customer Number is required.

2. For printing on the patent front page, list
 (1) the names of up to 3 registered patent attorneys or agents OR, alternatively, 1 _____
 (2) the name of a single firm (having as a member a registered attorney or agent) and the names of up to 2 registered patent attorneys or agents. If no name is listed, no name will be printed. 2 _____
 3 _____

3. ASSIGNEE NAME AND RESIDENCE DATA TO BE PRINTED ON THE PATENT (print or type)
 PLEASE NOTE: Unless an assignee is identified below, no assignee data will appear on the patent. If an assignee is identified below, the document has been filed for recordation as set forth in 37 CFR 3.11. Completion of this form is NOT a substitute for filing an assignment.

(A) NAME OF ASSIGNEE _____ (B) RESIDENCE: (CITY and STATE OR COUNTRY) _____

Please check the appropriate assignee category or categories (will not be printed on the patent): Individual Corporation or other private group entity Government

4a. The following fee(s) are enclosed:
 Issue Fee
 Publication Fee (No small entity discount permitted)
 Advance Order - # of Copies _____

4b. Payment of Fee(s):
 A check in the amount of the fee(s) is enclosed.
 Payment by credit card. Form PTO-2038 is attached.
 The Director is hereby authorized by charge the required fee(s), or credit any overpayment, to Deposit Account Number _____ (enclose an extra copy of this form).

5. Change in Entity Status (from status indicated above)
 a. Applicant claims SMALL ENTITY status. See 37 CFR 1.27. b. Applicant is no longer claiming SMALL ENTITY status. See 37 CFR 1.27(g)(2).

The Director of the USPTO is requested to apply the Issue Fee and Publication Fee (if any) or to re-apply any previously paid issue fee to the application identified above.
 NOTE: The Issue Fee and Publication Fee (if required) will not be accepted from anyone other than the applicant, a registered attorney or agent, or the assignee or other party in interest as shown by the records of the United States Patent and Trademark Office.

Authorized Signature _____ Date _____
 Typed or printed name _____ Registration No. _____

This collection of information is required by 37 CFR 1.311. The information is required to obtain or retain a benefit by the public which is to file (and by the USPTO to process) an application. Confidentiality is governed by 35 U.S.C. 122 and 37 CFR 1.14. This collection is estimated to take 12 minutes to complete, including gathering, preparing, and submitting the completed application form to the USPTO. Time will vary depending upon the individual case. Any comments on the amount of time you require to complete this form and/or suggestions for reducing this burden, should be sent to the Chief Information Officer, U.S. Patent and Trademark Office, U.S. Department of Commerce, P.O. Box 1450, Alexandria, Virginia 22313-1450. DO NOT SEND FEES OR COMPLETED FORMS TO THIS ADDRESS. SEND TO: Commissioner for Patents, P.O. Box 1450, Alexandria, Virginia 22313-1450.

Under the Paperwork Reduction Act of 1995, no persons are required to respond to a collection of information unless it displays a valid OMB control number.



UNITED STATES PATENT AND TRADEMARK OFFICE

UNITED STATES DEPARTMENT OF COMMERCE
United States Patent and Trademark Office
Address: COMMISSIONER FOR PATENTS
P.O. Box 1450
Alexandria, Virginia 22313-1450
www.uspto.gov

APPLICATION NO.	FILING DATE	FIRST NAMED INVENTOR	ATTORNEY DOCKET NO.	CONFIRMATION NO.
09/792,436	02/23/2001	Patrick Pirim	20046H-000100	9956

20350 7590 10/06/2004
TOWNSEND AND TOWNSEND AND CREW, LLP
TWO EMBARCADERO CENTER
EIGHTH FLOOR
SAN FRANCISCO, CA 94111-3834

EXAMINER

DAVIS, GEORGE B

ART UNIT PAPER NUMBER

2121

DATE MAILED: 10/06/2004

Determination of Patent Term Adjustment under 35 U.S.C. 154 (b)
(application filed on or after May 29, 2000)

The Patent Term Adjustment to date is 335 day(s). If the issue fee is paid on the date that is three months after the mailing date of this notice and the patent issues on the Tuesday before the date that is 28 weeks (six and a half months) after the mailing date of this notice, the Patent Term Adjustment will be 335 day(s).

If a Continued Prosecution Application (CPA) was filed in the above-identified application, the filing date that determines Patent Term Adjustment is the filing date of the most recent CPA.

Applicant will be able to obtain more detailed information by accessing the Patent Application Information Retrieval (PAIR) WEB site (<http://pair.uspto.gov>).

Any questions regarding the Patent Term Extension or Adjustment determination should be directed to the Office of Patent Legal Administration at (703) 305-1383. Questions relating to issue and publication fee payments should be directed to the Customer Service Center of the Office of Patent Publication at (703) 305-8283.



UNITED STATES PATENT AND TRADEMARK OFFICE

UNITED STATES DEPARTMENT OF COMMERCE
United States Patent and Trademark Office
Address: COMMISSIONER FOR PATENTS
P.O. Box 1450
Alexandria, Virginia 22313-1450
www.uspto.gov

Table with 5 columns: APPLICATION NO., FILING DATE, FIRST NAMED INVENTOR, ATTORNEY DOCKET NO., CONFIRMATION NO.
09/792,436 02/23/2001 Patrick Pirim 20046H-000100 9956

20350 7590 10/06/2004
TOWNSEND AND TOWNSEND AND CREW, LLP
TWO EMBARCADERO CENTER
EIGHTH FLOOR
SAN FRANCISCO, CA 94111-3834

EXAMINER

DAVIS, GEORGE B

ART UNIT PAPER NUMBER

2121

DATE MAILED: 10/06/2004

Notice of Fee Increase on October 1, 2004

If a reply to a "Notice of Allowance and Fee(s) Due" is filed in the Office on or after October 1, 2004, then the amount due will be higher than that set forth in the "Notice of Allowance and Fee(s) Due" because some fees will increase effective October 1, 2004. See Revision of Patent Fees for Fiscal Year 2005; Final Rule, 69 Fed. Reg. 52604, 52606 (May 10, 2004).

The current fee schedule is accessible from WEB site (http://www.uspto.gov/main/howtofees.htm).

If the fee paid is the amount shown on the "Notice of Allowance and Fee(s) Due" but not the correct amount in view of the fee increase, a "Notice of Pay Balance of Issue Fee" will be mailed to applicant. In order to avoid processing delays associated with mailing of a "Notice of Pay Balance of Issue Fee," if the response to the Notice of Allowance is to be filed on or after October 1, 2004 (or mailed with a certificate of mailing on or after October 1, 2004), the issue fee paid should be the fee that is required at the time the fee is paid. See Manual of Patent Examining Procedure (MPEP), Section 1306 (Eighth Edition, Rev. 2, May 2004). If the issue fee was previously paid, and the response to the "Notice of Allowance and Fee(s) Due" includes a request to apply a previously-paid issue fee to the issue fee now due, then the difference between the issue fee amount at the time the response is filed and the previously-paid issue fee should be paid. See MPEP Section 1308.01.

Effective October 1, 2004, 37 CFR 1.18 is amended by revising paragraphs (a) through (c) to read as set forth below.

Section 1.18 Patent post allowance (including issue) fees.

- (a) Issue fee for issuing each original or reissue patent, except a design or plant patent:
By a small entity (Sec. 1.27(a))..... \$685.00
By other than a small entity..... \$1,370.00
(b) Issue fee for issuing a design patent:
By a small entity (Sec. 1.27(a))..... \$245.00
By other than a small entity..... \$490.00
(c) Issue fee for issuing a plant patent:
By a small entity (Sec. 1.27(a))..... \$330.00
By other than a small entity..... \$660.00

Questions relating to issue and publication fee payments should be directed to the Customer Service Center of the Office of Patent Publication at (703) 305-8283.

8

Notice of Allowability	Application No.	Applicant(s)	
	09/792,436	PIRIM, PATRICK	
	Examiner	Art Unit	
	George Davis	2121	

-- The MAILING DATE of this communication appears on the cover sheet with the correspondence address--

All claims being allowable, PROSECUTION ON THE MERITS IS (OR REMAINS) CLOSED in this application. If not included herewith (or previously mailed), a Notice of Allowance (PTOL-85) or other appropriate communication will be mailed in due course. **THIS NOTICE OF ALLOWABILITY IS NOT A GRANT OF PATENT RIGHTS.** This application is subject to withdrawal from issue at the initiative of the Office or upon petition by the applicant. See 37 CFR 1.313 and MPEP 1308.

- 1. This communication is responsive to 8/30/2004.
- 2. The allowed claim(s) is/are 1-29.
- 3. The drawings filed on _____ are accepted by the Examiner.
- 4. Acknowledgment is made of a claim for foreign priority under 35 U.S.C. § 119(a)-(d) or (f).
 - a) All b) Some* c) None of the:
 - 1. Certified copies of the priority documents have been received.
 - 2. Certified copies of the priority documents have been received in Application No. _____.
 - 3. Copies of the certified copies of the priority documents have been received in this national stage application from the International Bureau (PCT Rule 17.2(a)).
 - * Certified copies not received: _____.

Applicant has THREE MONTHS FROM THE "MAILING DATE" of this communication to file a reply complying with the requirements noted below. Failure to timely comply will result in ABANDONMENT of this application.
THIS THREE-MONTH PERIOD IS NOT EXTENDABLE.

- 5. A SUBSTITUTE OATH OR DECLARATION must be submitted. Note the attached EXAMINER'S AMENDMENT or NOTICE OF INFORMAL PATENT APPLICATION (PTO-152) which gives reason(s) why the oath or declaration is deficient.
- 6. CORRECTED DRAWINGS (as "replacement sheets") must be submitted.
 - (a) including changes required by the Notice of Draftsperson's Patent Drawing Review (PTO-948) attached
 - 1) hereto or 2) to Paper No./Mail Date _____.
 - (b) including changes required by the attached Examiner's Amendment / Comment or in the Office action of Paper No./Mail Date 3/26/2004.

Identifying indicia such as the application number (see 37 CFR 1.84(c)) should be written on the drawings in the front (not the back) of each sheet. Replacement sheet(s) should be labeled as such in the header according to 37 CFR 1.121(d).
- 7. DEPOSIT OF and/or INFORMATION about the deposit of BIOLOGICAL MATERIAL must be submitted. Note the attached Examiner's comment regarding REQUIREMENT FOR THE DEPOSIT OF BIOLOGICAL MATERIAL.

Attachment(s)

- 1. Notice of References Cited (PTO-892)
- 2. Notice of Draftsperson's Patent Drawing Review (PTO-948)
- 3. Information Disclosure Statements (PTO-1449 or PTO/SB/08), Paper No./Mail Date 6/22/2004
- 4. Examiner's Comment Regarding Requirement for Deposit of Biological Material
- 5. Notice of Informal Patent Application (PTO-152)
- 6. Interview Summary (PTO-413), Paper No./Mail Date _____
- 7. Examiner's Amendment/Comment
- 8. Examiner's Statement of Reasons for Allowance
- 9. Other _____

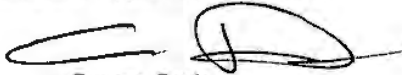
 George Davis
 Primary Examiner
 Art Unit: 2121



Substitute for form 1449A/PTO

INFORMATION DISCLOSURE STATEMENT BY APPLICANT

(Use as many sheets as necessary)

Sheet 1 of 1

Complete if Known

Application Number	09/792,436
Filing Date	February 23, 2001
First Named Inventor	Pirim, Patrick
Art Unit	2121
Examiner Name	Davis, George B.
Attorney Docket Number	20046H-000100US

U.S. PATENT DOCUMENTS						
Examiner	Cite No. ¹	Document Number		Publication Date MM-DD-YYYY	Name of Patentee or Applicant of Cited Document	Pages, Columns, Lines, Where Relevant Passages or Relevant Figures Appear
		Number	Kind Code ² (# known)			
GD	1	US-5,008,946		04-16-1991	Ando	class / subclass 382 / 104
GD	2	US-5,625,717		04-29-1997	Hashimoto et al.	382 / 260
						RECEIVED JUN 28 2004 Technology Center 2100

FOREIGN PATENT DOCUMENTS								
Examiner Initials ⁶	Cite No. ¹	Foreign Patent Document			Publication Date MM-DD-YYYY	Name of Patentee or Applicant of Cited Document	Pages, Columns, Lines, Where Relevant Passages or Relevant Figures Appear	T ⁸
		Country Code ³	Number ⁴	Kind Code ⁵ (# known)				
								<input type="checkbox"/>
								<input type="checkbox"/>
								<input type="checkbox"/>
								<input type="checkbox"/>
								<input type="checkbox"/>
								<input type="checkbox"/>

Examiner Signature	George Davis	Date Considered	9/30/04
--------------------	--------------	-----------------	---------

¹EXAMINER: Initial if reference considered, whether or not citation is in conformance with MPEP 609. Draw line through citation if not in conformance and not considered. Include copy of this form with next communication to applicant. ² Applicant's unique citation designation number (optional). ³ See Kind Codes of USPTO Patent Documents at www.uspto.gov or MPEP 901.04. ⁴ Enter Office that issued the document, by the two-letter code (WIPO Standard ST.3). ⁵ For Japanese patent documents, the indication of the year of the reign of the Emperor must precede the serial number of the patent document. ⁶ Kind of document by the appropriate symbols as indicated on the document under WIPO Standard ST. 16 if possible. ⁷ Applicant is to place a check mark here if English language Translation is attached.



UNITED STATES PATENT AND TRADEMARK OFFICE

COMMISSIONER FOR PATENTS
 UNITED STATES PATENT AND TRADEMARK OFFICE
 WASHINGTON, D.C. 20231
 www.uspto.gov



Bib Data Sheet

CONFIRMATION NO. 9956

SERIAL NUMBER 09/792,436	FILING DATE 02/23/2001 RULE	CLASS 706	GROUP ART UNIT 2124	ATTORNEY DOCKET NO. 20046H-000100	
APPLICANTS Patrick Pirim, Paris, FRANCE: <i>C.D. none</i>					
** CONTINUING DATA <i>C.D.</i>					
** FOREIGN APPLICATIONS FRANCE 00 02355 02/24/2000					
IF REQUIRED, FOREIGN FILING LICENSE GRANTED ** 03/23/2001					
Foreign Priority claimed 35 USC 119 (a-d) conditions met Verified and Acknowledged	<input checked="" type="checkbox"/> yes <input type="checkbox"/> no <input type="checkbox"/> yes <input checked="" type="checkbox"/> no <input type="checkbox"/> Met after Allowance <i>C.D.</i> Examiner's Signature Initials	STATE OR COUNTRY FRANCE	SHEETS DRAWING 31	TOTAL CLAIMS 28	INDEPENDENT CLAIMS 6
ADDRESS 20350					
TITLE Method and device for automatic visual perception					
FILING FEE RECEIVED 1266	FEES: Authority has been given in Paper No. _____ to charge/credit DEPOSIT ACCOUNT No. _____ for following:		<input type="checkbox"/> All Fees <input type="checkbox"/> 1.16 Fees (Filing) <input type="checkbox"/> 1.17 Fees (Processing Ext. of time) <input type="checkbox"/> 1.18 Fees (Issue) <input type="checkbox"/> Other _____ <input type="checkbox"/> Credit		

Index of Claims



Application No.

09/792,436

Examiner

George Davis

Applicant(s)

PIRIM, PATRICK

Art Unit

2121

√	Rejected
=	Allowed

-	(Through numeral) Cancelled
+	Restricted

N	Non-Elected
I	Interference

A	Appeal
O	Objected

10/23/04

Claim		Date	
Final	Original		
1	1	=	
2	2	=	
3	3	=	
4	4	=	
5	5	=	
6	6	=	
7	7	=	
8	8	=	
9	9	=	
10	10	=	
11	11	=	
12	12	=	
13	13	=	
14	14	=	
15	15	=	
16	16	=	
18	17	=	
19	18	=	
20	19	=	
21	20	=	
22	21	=	
23	22	=	
24	23	=	
25	24	=	
26	25	=	
27	26	=	
28	27	=	
29	28	=	
17	29	=	
	30		
	31		
	32		
	33		
	34		
	35		
	36		
	37		
	38		
	39		
	40		
	41		
	42		
	43		
	44		
	45		
	46		
	47		
	48		
	49		
	50		

Claim		Date	
Final	Original		
	51		
	52		
	53		
	54		
	55		
	56		
	57		
	58		
	59		
	60		
	61		
	62		
	63		
	64		
	65		
	66		
	67		
	68		
	69		
	70		
	71		
	72		
	73		
	74		
	75		
	76		
	77		
	78		
	79		
	80		
	81		
	82		
	83		
	84		
	85		
	86		
	87		
	88		
	89		
	90		
	91		
	92		
	93		
	94		
	95		
	96		
	97		
	98		
	99		
	100		

Claim		Date	
Final	Original		
	101		
	102		
	103		
	104		
	105		
	106		
	107		
	108		
	109		
	110		
	111		
	112		
	113		
	114		
	115		
	116		
	117		
	118		
	119		
	120		
	121		
	122		
	123		
	124		
	125		
	126		
	127		
	128		
	129		
	130		
	131		
	132		
	133		
	134		
	135		
	136		
	137		
	138		
	139		
	140		
	141		
	142		
	143		
	144		
	145		
	146		
	147		
	148		
	149		
	150		

Issue Classification 	Application No. 09/792,436	Applicant(s) PIRIM, PATRICK	
	Examiner George Davis	Art Unit 2121	

ISSUE CLASSIFICATION										
ORIGINAL					CROSS REFERENCE(S)					
CLASS		SUBCLASS			CLASS	SUBCLASS (ONE SUBCLASS PER BLOCK)				
706		20			702	78				
INTERNATIONAL CLASSIFICATION					382	133				
G	0	8	F	15/18						
G	0	1	R	23/10						
G	0	8	K	9/00						
				/						
				/						

(Assistant Examiner) (Date)	 George Davis (Primary Examiner)	Total Claims Allowed: 29	
(Legal Instruments Examiner) (Date)		O.G. Print Claim(s) 1	O.G. Print Fig. 4

<input type="checkbox"/> Claims renumbered in the same order as presented by applicant		<input type="checkbox"/> CPA		<input type="checkbox"/> T.D.		<input type="checkbox"/> R.1.47							
Final	Original	Final	Original	Final	Original	Final	Original						
1	1		31		61		91		121		151		181
2	2		32		62		92		122		152		182
3	3		33		63		93		123		153		183
4	4		34		64		94		124		154		184
5	5		35		65		95		125		155		185
6	6		36		66		96		126		156		186
7	7		37		67		97		127		157		187
8	8		38		68		98		128		158		188
9	9		39		69		99		129		159		189
10	10		40		70		100		130		160		190
11	11		41		71		101		131		161		191
12	12		42		72		102		132		162		192
13	13		43		73		103		133		163		193
14	14		44		74		104		134		164		194
15	15		45		75		105		135		165		195
16	16		46		76		106		136		166		196
18	17		47		77		107		137		167		197
19	18		48		78		108		138		168		198
20	19		49		79		109		139		169		199
21	20		50		80		110		140		170		200
22	21		51		81		111		141		171		201
23	22		52		82		112		142		172		202
24	23		53		83		113		143		173		203
25	24		54		84		114		144		174		204
26	25		55		85		115		145		175		205
27	26		56		86		116		146		176		206
28	27		57		87		117		147		177		207
29	28		58		88		118		148		178		208
17	29		59		89		119		149		179		209
	30		60		90		120		150		180		210

Search Notes



Application No.

09/792,436

Examiner

George Davis

Applicant(s)

PIRIM, PATRICK

Art Unit

2121

SEARCHED			
Class	Subclass	Date	Examiner
706	20	9/30/2004	GD
702	78	9/30/2004	GD
382	133	9/30/2004	GD

INTERFERENCE SEARCHED			
Class	Subclass	Date	Examiner
706	20	9/30/2004	GD

SEARCH NOTES (INCLUDING SEARCH STRATEGY)		
	DATE	EXMR
IEEE, EAST	9/30/2004	GD



BREVET D'INVENTION

CERTIFICAT D'UTILITÉ - CERTIFICAT D'ADDITION

COPIE OFFICIELLE

Le Directeur général de l'Institut national de la propriété industrielle certifie que le document ci-annexé est la copie certifiée conforme d'une demande de titre de propriété industrielle déposée à l'Institut.

Fait à Paris, le 27 FEV. 2007

Pour le Directeur général de l'Institut
national de la propriété industrielle
Le Chef du Département des brevets

CERTIFIED COPY OF
PRIORITY DOCUMENT

Martine PLANCHE

THIS PAGE BLANK (USPTO)



26 bis, rue de Saint Pétersbourg
75800 Paris Cedex 08
Téléphone : 01 53 04 53 04 Télécopie : 01 42 94 86 54

BREVET D'INVENTION CERTIFICAT D'UTILITÉ

Code de la propriété intellectuelle - Livre VI



N° 11354*01

REQUÊTE EN DÉLIVRANCE 1/2

Cet imprimé est à remplir lisiblement à l'encre noire.

DB 540 W 252899

REMISE DES PIÈCES DATE 24 FEV. 2000 LIEU N° D'ENREGISTREMENT 0002355 NATIONAL ATTRIBUÉ PAR L'INPI DATE DE DÉPÔT ATTRIBUÉE PAR L'INPI 24 FEV. 2000		Réservé à l'INPI 1 NOM ET ADRESSE DU DEMANDEUR OU DU MANDATAIRE À QUI LA CORRESPONDANCE DOIT ÊTRE ADRESSÉE CABINET HARLE ET PHELIP 7, rue de Madrid 75008 PARIS FRANCE	
Vos références pour ce dossier <i>(facultatif)</i>		FR 62308 L	
Confirmation d'un dépôt par télécopie		<input type="checkbox"/> N° attribué par l'INPI à la télécopie	
2 NATURE DE LA DEMANDE		Cochez l'une des 4 cases suivantes	
Demande de brevet		<input checked="" type="checkbox"/>	
Demande de certificat d'utilité		<input type="checkbox"/>	
Demande divisionnaire		<input type="checkbox"/>	
<i>Demande de brevet initiale</i>		N°	Date / /
<i>ou demande de certificat d'utilité initiale</i>		N°	Date / /
Transformation d'une demande de brevet européen <i>Demande de brevet initiale</i>		<input type="checkbox"/>	
		N°	Date / /
3 TITRE DE L'INVENTION (200 caractères ou espaces maximum)			
Procédé et dispositif de perception automatique			
4 DÉCLARATION DE PRIORITÉ OU REQUÊTE DU BÉNÉFICE DE LA DATE DE DÉPÔT D'UNE DEMANDE ANTÉRIEURE FRANÇAISE		Pays ou organisation Date / / N° Pays ou organisation Date / / N° Pays ou organisation Date / / N° <input type="checkbox"/> S'il y a d'autres priorités, cochez la case et utilisez l'imprimé «Suite»	
5 DEMANDEUR		<input type="checkbox"/> S'il y a d'autres demandeurs, cochez la case et utilisez l'imprimé «Suite»	
Nom ou dénomination sociale		HOLDING B.E.V. S.A.	
Prénoms			
Forme juridique			
N° SIREN			
Code APE-NAF			
Adresse	Rue	69, route d'Esch	
	Code postal et ville	L-2953	Luxembourg
Pays		LUXEMBOURG	
Nationalité		Luxembourgeoise	
N° de téléphone <i>(facultatif)</i>			
N° de télécopie <i>(facultatif)</i>			
Adresse électronique <i>(facultatif)</i>			



BREVET D'INVENTION
CERTIFICAT D'UTILITÉ
 Code de la propriété intellectuelle - Livre VI



DÉPARTEMENT DES BREVETS

26 bis, rue de Saint Pétersbourg
 75800 Paris Cedex 08
 Téléphone : 01 53 04 53 04 Télécopie : 01 42 94 86 54

DÉSIGNATION D'INVENTEUR(S) Page N° 1 / 1.
 (Si le demandeur n'est pas l'inventeur ou l'unique inventeur)

Cet imprimé est à remplir lisiblement à l'encre noire

DB 113 W / 260899

Vos références pour ce dossier <i>(facultatif)</i>		FR 62308 L	
N° D'ENREGISTREMENT NATIONAL		0002355	
TITRE DE L'INVENTION (200 caractères ou espaces maximum)			
Procédé et dispositif de perception automatique.			
LE(S) DEMANDEUR(S) :			
HOLDING B.E.V. S.A.			
DESIGNE(NT) EN TANT QU'INVENTEUR(S) : (Indiquez en haut à droite «Page N° 1/1» S'il y a plus de trois inventeurs, utilisez un formulaire identique et numérotez chaque page en indiquant le nombre total de pages).			
Nom		PIRIM	
Prénoms		Patrick	
Adresse	Rue	56, rue Patay	
	Code postal et ville	75013	PARIS
Société d'appartenance <i>(facultatif)</i>			
Nom			
Prénoms			
Adresse	Rue		
	Code postal et ville		
Société d'appartenance <i>(facultatif)</i>			
Nom			
Prénoms			
Adresse	Rue		
	Code postal et ville		
Société d'appartenance <i>(facultatif)</i>			
DATE ET SIGNATURE(S) DU (DES) DEMANDEUR(S) OU DU MANDATAIRE (Nom et qualité du signataire)		PARIS, LE 24 FEVRIER 2000 MICHELET Alain C.P.I. bm (92-1176 i) Cabinet HARLE & PHELIP 	

La loi n°78-17 du 6 janvier 1978 relative à l'informatique, aux fichiers et aux libertés s'applique aux réponses faites à ce formulaire. Elle garantit un droit d'accès et de rectification pour les données vous concernant auprès de l'INPI.

DOCUMENT COMPORTANT DES MODIFICATIONS

PAGE(S) DE LA DESCRIPTION OU DES REVENDEICATIONS OU PLANCHE(S) DE DESSIN			R.M.*	DATE DE LA CORRESPONDANCE	TAMPON DATEUR DU CORRECTEUR
Modifiée(s)	Supprimée(s)	Ajoutée(s)			
1				5.05.2022	15.05.2022 AL

Un changement apporté à la rédaction des revendications d'origine, sauf si celui-ci découle des dispositions de l'article R.612-36 du code de la Propriété Intellectuelle, est signalé par la mention «R.M.» (revendications modifiées).

44-11-1004-14

L'invention concerne un procédé et un dispositif de perception automatique. Le dispositif comporte une unité de calcul d'histogramme, de préférence auto-adaptative éventuellement avec anticipation et apprentissage. Ils sont plus particulièrement destinés à la perception et au
5 traitement d'images.

On connaît des procédés et des dispositifs de traitement d'images permettant, en temps réel, de reconnaître, de localiser et/ou d'extraire des objets correspondants à certains critères de leur contexte.

Les critères de sélections peuvent être extrêmement variés. Il peut
10 s'agir d'une vitesse, d'une forme, d'une couleur... ou d'une combinaison de ces critères.

Ces procédés et dispositifs peuvent être utilisés pour faciliter l'appréhension d'une scène ou d'un phénomène par un observateur ou pour commander un automatisme à partir des informations ainsi extraites.

15 De tels procédés et dispositifs sont par exemple décrits dans les publications suivantes FR-2.611.063 et WO-98/05002.

Certains de ces procédés et dispositifs mettent en œuvre une unité de traitement spatial et temporel qui, recevant un signal $S(PI)$ de type vidéo, produit un certains nombre de paramètres pour chaque pixel. Il s'agit par
20 exemple de la vitesse V , de la direction DL , d'une constante de temps CO , et d'un paramètre binaire de validation VL en plus du signal vidéo retardé VR et des différents signaux de synchronisation de trame, de ligne et de pixel regroupés sous la dénomination F .

Dans de tels dispositifs, on a déjà souligné l'intérêt de constituer des
25 histogrammes de ces paramètres permettant la constitution la manipulation et l'exploitation d'informations statistiques.

Le but de ces procédés et de ces dispositifs de traitement d'images est de fournir en sortie un signal $S'(t)$ qui porte pour chaque pixel une information significative du résultat de l'application de critères de reconnaissance ou de
30 sélection. Ces critères sont prédéfinis ou élaborés par les procédés et dispositifs de traitements d'images eux mêmes.

On connaît en particulier un tel procédé et un tel dispositif décrit dans la demande de brevet WO-98/05002, déjà citée qui est incorporée ici par référence.



2121
Jfer

PTO/SB/21 (04-04)

TRANSMITTAL FORM <small>(to be used for all correspondence after initial filing)</small>	Application Number	09/792,436
	Filing Date	February 23, 2001
	First Named Inventor	Pirim, Patrick
	Art Unit	2121
	Examiner Name	George B. Davis
	Attorney Docket Number	20046H-000100US
Total Number of Pages in This Submission		

ENCLOSURES <small>(Check all that apply)</small>		
<input checked="" type="checkbox"/> Fee Transmittal Form	<input checked="" type="checkbox"/> Drawing(s) (12 sheets) (annotated, showing changes)	<input type="checkbox"/> After Allowance Communication to Technology Center (TC)
<input type="checkbox"/> Fee Attached	<input type="checkbox"/> Licensing-related Papers	<input type="checkbox"/> Appeal Communication to Board of Appeals and Interferences
<input checked="" type="checkbox"/> Amendment/Reply	<input type="checkbox"/> Petition	<input type="checkbox"/> Appeal Communication to TC (Appeal Notice, Brief, Reply Brief)
<input type="checkbox"/> After Final	<input type="checkbox"/> Petition to Convert to a Provisional Application	<input type="checkbox"/> Proprietary Information
<input type="checkbox"/> Affidavits/declaration(s)	<input type="checkbox"/> Power of Attorney, Revocation Change of Correspondence Address	<input type="checkbox"/> Status Letter
<input checked="" type="checkbox"/> Extension of Time Request	<input type="checkbox"/> Terminal Disclaimer	<input checked="" type="checkbox"/> Other Enclosure(s) (please identify below):
<input type="checkbox"/> Express Abandonment Request	<input type="checkbox"/> Request for Refund	Return Postcard
<input type="checkbox"/> Information Disclosure Statement	<input type="checkbox"/> CD, Number of CD(s)	
<input checked="" type="checkbox"/> Certified Copy of Priority Document(s)	Remarks: The Commissioner is authorized to charge any additional fees to Deposit Account 20-1430.	
<input type="checkbox"/> Response to Missing Parts/Incomplete Application		
<input type="checkbox"/> Response to Missing Parts under 37 CFR 1.52 or 1.53		

SIGNATURE OF APPLICANT, ATTORNEY, OR AGENT	
Firm or Individual name	Townsend and Townsend and Crew LLP Gerald T. Gray Reg. No. 41,797
Signature	<i>Gerald T. Gray</i>
Date	August 26, 2004

CERTIFICATE OF TRANSMISSION/MAILING	
I hereby certify that this correspondence is being deposited with the United States Postal Service with sufficient postage as first class mail in an envelope addressed to: Commissioner for Patents, P.O. Box 1450, Alexandria, VA 22313-1450 on the date shown below.	
Typed or printed name	Sylvia E. Arnold
Signature	<i>Sylvia E. Arnold</i>
Date	August 26, 2004



Le but de l'invention est de proposer un procédé et un dispositif de perception automatique rapide et efficace et d'améliorer pour un tel dispositif les unités de constitution d'histogrammes en assurant des fonctions d'auto-adaptation et, dans des modes de réalisation préférés d'anticipation et d'apprentissage.

La présente invention concerne à cet effet un dispositif de perception automatique d'un événement intervenant dans un espace par rapport à au moins un paramètre.

Selon l'invention, ce dispositif comporte une unité de contrôle, un bus de données, un bus de rétroannotation et au moins une unité de calcul d'histogramme pour le traitement du paramètre.

La présente invention concerne également les caractéristiques qui ressortiront au cours de la description qui va suivre et qui devront être considérées isolément ou selon toutes leurs combinaisons techniques possibles :

- le dispositif comporte, pour traiter plusieurs paramètres, plusieurs unités de calcul d'histogramme organisées en matrice ;
- les unités de calcul d'histogramme traitent des données a_{ijk} associées à des pixels formant ensemble un espace multidimensionnel évoluant dans le temps et représenté à une succession de moments, les données parvenant à l'unité de calcul sous la forme d'un signal DATA(A) numérique sous forme d'une suite a_{ijk} de nombre binaire de n bits associé à des signaux de synchronisation permettant de définir le moment donné de l'espace et la position du pixel dans cet espace, auquel le signal a_{ijk} reçu à un instant donné est associé, comprenant :
 - une mémoire d'analyse comportant une mémoire avec des adresses, chacune associée à des valeurs possibles des nombres de n bits du signal DATA(A) et dont l'écriture est contrôlée par un signal " WRITE ",
 - un classifieur comportant une mémoire destinée à recevoir un critère C de sélection du paramètre DATA(A), recevant le signal DATA(A) en entrée et fournissant, en sortie, un signal binaire de classification dont la valeur dépend du résultat de la comparaison du signal DATA(A) avec le critère C de sélection,

- une unité de rétroannotation recevant le signal de sortie du classifieur et, de l'extérieur de l'unité de calcul de l'histogramme, des signaux binaires de classification individuels concernant des paramètres autres que DATA(A), ladite unité de rétroannotation fournissant en sortie
 - 5 un signal de validation global positif lorsque l'ensemble des signaux de rétroannotation individuels sont positifs,
 - une unité de test,
 - une unité de sortie d'analyse,
 - un multiplexeur d'adresses,
 - 10 - une unité de validation d'incrémentement,
- le compteur de chaque adresse de la mémoire correspondant à la valeur d de a_{ijt} à un instant donné, étant incrémentée d'une unité lorsque l'unité de rétroannotation fournit en sortie un signal de validation global positif,
- 15 l'unité de calcul et de mémorisation de données statistiques exploitant à la fin de la réception des données a_{ijt} correspondant à l'espace à un moment le contenu de la mémoire pour mettre à jour l'unité de sortie d'analyse,
- la mémoire étant effacée avant le début de chaque trame pour un
 - 20 espace à un moment par un signal d'initialisation " INIT ",
 - et en outre :
 - la mémoire du classifieur est une mémoire adressable permettant la mise à jour en temps réel du critère de sélection et ayant une entrée de données DATA IN, une commande d'adresse ADRESS et une commande
 - 25 d'écriture WR, recevant sur son entrée la sortie de la mémoire d'analyse et un signal END sur sa commande d'écriture,
 - les unités de traitement d'histogramme comportent, de plus, un multiplexeur d'entrée de données ayant deux entrées et une sortie, recevant sur l'une de ses entrées un signal de comptage COUNTER et, sur l'autre de ses entrées, la suite de données a_{ijt} et fournissant en sortie
 - 30 la suite de données a_{ijt} à la commande d'adresse de la mémoire du classifieur et un opérateur OU commandant le multiplexeur d'adresse et recevant sur ses entrées un signal d'initialisation INIT et le signal de fin END ;

- l'espace est à deux dimensions et le signal DATA(A) est associé aux pixels d'une succession d'images ;
- les unités de traitements d'histogramme comportent des moyens d'anticipation de la valeur du critère de sélection ;
- 5 - les moyens d'anticipation de la valeur du critère de sélection comportent des mémoires destinées à contenir les valeurs de paramètres statistiques relatives à deux trames successives ;
- les paramètres statistiques sont les valeurs moyennes des données a_{ijt} validées ;
- 10 - le registre de sortie d'analyse des unités de calcul d'histogramme constitue et garde en mémoire l'une au moins des valeurs suivantes : la valeur minimum " MIN ", la valeur maximum " MAX ", le nombre maximum de pixels pour lesquels le signal V_{ijt} a une valeur particulière " RMAX ", la valeur particulière correspondante POSRMAX, le nombre total de pixels validés
- 15 " NBPTS " ;
- le paramètre statistique de comparaison utilisé par le classifieur est RMAX/2 ;
- elle comporte un multiplexeur commandé, pouvant recevoir en entrée plusieurs paramètres statistiques et la nature de la comparaison faite par le
- 20 classifieur dépend de la commande de ce multiplexeur ;
- certaines unités de calcul d'histogramme, au moins, comportent un multiplexeur d'apprentissage destiné à recevoir un signal de commande extérieur et produisant un fonctionnement selon un mode d'apprentissage dans lequel les registres du classifieur et de l'unité de rétroannotation sont
- 25 effacés au début de l'exploitation d'une trame et que le registre de sortie d'analyse fournit des valeurs caractéristiques de la séquence pour chacun de ces registres ;
- dans certaines unités de calcul d'histogramme, au moins, la mémoire du classifieur est constituée d'un ensemble de registres indépendants
- 30 comportant chacun une entrée, une sortie et une commande d'écriture, le nombre de ces registres étant égal au nombre n de bits des nombres de la suite V_{ijt} , et elle comporte un décodeur permettant de sortir un signal de commande d'écriture correspondant à la valeur d'entrée (adresse) associée et un multiplexeur commandé par cette valeur d'entrée, permettant de lire le
- 35 registre choisi ;

- certaines unités de calcul d'histogramme au moins, comportent des multiplexeurs, un d'entre eux étant associé à l'entrée de chaque registre et des modules combinatoires reliant entre eux les registres, les multiplexeurs permettant le choix entre l'écriture séquentielle et une écriture commune à tous les registres liés entre eux par les modules combinatoires ;

5
- dans certaines unités de calcul d'histogramme au moins, les modules combinatoires comportent un opérateur morphologique de dilatation comportant une unité logique " OU " à trois entrées dont la première reçoit le signal de sortie du registre de rang " Q ", la deuxième est reliée à la sortie d'une unité logique " ET " à deux entrées recevant respectivement le signal de sortie du registre de rang " Q+1 " et un signal de dilatation positive, la troisième est reliée à la sortie d'une unité logique " ET " à deux entrées recevant respectivement le signal de sortie du registre de rang " Q-1 " et un signal de dilatation négative ;

15
- dans certaines unités de calcul d'histogramme au moins, les modules combinatoires comportent un opérateur morphologique d'érosion comportant une unité logique " ET " à trois entrées dont la première reçoit le signal de sortie du registre de rang " Q ", la deuxième est reliée à la sortie d'une unité logique " ET " dont une inversée à quatre entrées recevant respectivement le signal de sortie du registre de rang " Q ", le signal de sortie du registre de rang " Q-1 ", le signal de sortie du registre de rang " Q+1 " et un signal d'érosion positive, la troisième est reliée à la sortie d'une unité logique " ET " à quatre entrées dont une inversée recevant respectivement le signal de sortie du registre de rang " Q ", le signal de sortie du registre de rang " Q-1 ", le signal de sortie du registre de rang " Q+1 " et un signal d'érosion négative ;

20
- dans certaines unités de calcul d'histogramme au moins, chaque module combinatoire comporte un multiplexeur associant un opérateur morphologique d'érosion et un opérateur morphologique d'érosion ;

30
L'invention concerne un procédé de perception automatique d'un événement intervenant dans un espace par rapport à au moins un paramètre consistant à le digitaliser et à le fournir en entrée à une unité de calcul d'histogramme pour former un histogramme représentatif du paramètre et en déduire le résultat désiré.

L'invention concerne également un procédé d'analyse d'un paramètre représentatif d'un événement dans un dispositif électronique comprenant un calcul d'histogramme sur des données a_{ijt} associées à des pixels formant ensemble un espace multidimensionnel évoluant dans le temps et représenté

5 à une succession de moments, les données parvenant à l'unité de calcul sous la forme d'un signal DATA(A) numérique sous forme d'une suite a_{ijt} de nombre binaire de n bits associé à des signaux de synchronisation permettant de définir le moment donné de l'espace et la position du pixel dans cet

10 espace, auquel le signal a_{ijt} reçu à un instant donné est associé dans lequel

- on associe à chaque donnée a_{ijt} un signal binaire de classification dont la valeur dépend du résultat de la comparaison du signal DATA(A) avec le critère C de sélection,
- on constitue une répartition statistique des données a_{ijt} pour un moment donné pour lesquelles un signal de validation global est positif,

15 ledit signal de validation global étant constitué d'un ensemble de signaux de rétroannotation individuels chacun correspondant à un paramètre DATA(A), DATA(B),...DATA(E), résultant de la comparaison entre un critère de rétroannotation R et de son signal de classification et étant positif.

20 L'invention sera décrite plus en détail en référence aux dessins annexés dans lesquels :

- la figure 1 est une représentation de l'unité de calcul d'histogramme selon l'invention, dans son contexte ;
- la figure 2 est une représentation du signal vidéo d'entrée, traité par

25 le dispositif et le procédé de l'invention et des signaux de commande générés par un séquenceur ;

- la figure 3 est un diagramme représentant une unité passive de calcul d'histogramme ;
- la figure 4 est un diagramme représentant une unité de calcul

30 d'histogramme autoadaptative selon l'invention avec les fonctionnalités d'anticipation et d'apprentissage ;

- la figure 5 est un diagramme représentant des signaux exploités par l'unité de calcul de la figure 4 ;
- la figure 6 est l'organigramme du logiciel de commande de l'unité de

35 calcul de la figure 4 en mode maître ;

- la figure 7 est l'organigramme du logiciel de commande de l'unité de calcul de la figure 4 en mode esclave ;
- la figure 8 est l'organigramme du logiciel d'insertion de la zone de courbe ;
- 5 - la figure 9 est l'organigramme du logiciel d'initialisation (génération de la commande « INIT ») ;
- la figure 10 est l'organigramme du logiciel de calcul de statistiques (utilisation de la commande « WRITE ») ;
- la figure 11 est l'organigramme de fin de traitement (utilisation de la
- 10 commande « END ») ;
- la figure 12 est une représentation des éléments essentiels de l'unité de calcul d'histogramme ayant une fonctionnalité d'autoadaptation ;
- la figure 13 est une représentation d'un calculateur de validation ayant plusieurs fonctionnalités d'autoadaptation ;
- 15 - la figure 14 est une représentation des éléments d'une unité de calcul d'histogramme produisant des valeurs POSMOY ;
- la figure 15 est un schéma représentant les éléments essentiels de l'unité d'histogramme autoadaptative avec anticipation selon une première méthode ;
- 20 - la figure 15a est une représentation analogue à la figure 15 mettant en œuvre une première méthode d'anticipation généralisée ;
- la figure 16 est un schéma de la mémoire du classifieur ;
- la figure 17 est un schéma représentant les éléments essentiels de l'unité d'histogramme autoadaptative avec anticipation selon une deuxième
- 25 méthode ;
- la figure 18 est une représentation détaillée de la mémoire du classifieur avec un automate de calcul élémentaire par bit ;
- la figure 19 est une représentation d'un automate élémentaire de calcul de l'anticipation ;
- 30 - la figure 20 est une représentation schématique de l'anticipation ;
- la figure 21 est l'organigramme du logiciel de mise en œuvre de l'anticipation ;
- la figure 22 est une représentation de l'unité de rétroannotation ;
- la figure 23 est une représentation synoptique d'une unité
- 35 reprogrammable logique (FPGA) utilisée comme unité de rétroannotation ;

- la figure 24 est la représentation par registre, limitée à une rangée du circuit, de la figure 23 ;
- la figure 25 est une représentation des éléments essentiels d'une unité de calcul d'histogramme permettant l'apprentissage ;
- 5 - les figures 26 et 27 sont des représentations schématiques d'un choix d'axe particulier ;
- la figure 28 est une représentation schématique du dispositif de visualisation statistique ;
- la figure 29 est un exemple du résultat de la visualisation produite par
- 10 le dispositif de la figure 28 ;
- la figure 30 est la représentation de la mise en œuvre d'une pluralité d'unités de calcul d'histogramme ;
- la figure 31 est la représentation de l'utilisation d'une unité de calcul d'histogramme unique programmable avec un multiplexeur permettant son
- 15 exploitation pour une pluralité de paramètres ;
- la figure 32 représente un ensemble d'unités de calcul d'histogramme à contrôle d'entrée programmable dans leur contexte d'utilisation constituant une unité fonctionnelle ;
- la figure 33 est une représentation synthétique d'une unité
- 20 fonctionnelle avec le générateur de signal associé ;
- la figure 34 correspond à la figure 32 dans le cas d'une acquisition à deux sources ;
- la figure 35 correspond à la figure 33 dans le cas d'une acquisition binoculaire ;
- 25 - la figure 36 schématise un générateur de signal équipé d'une optique commandée ;
- la figure 37 présente le cas d'une acquisition à trois sources ;
- la figure 38 est une représentation de l'interface de gestion de l'application (API) ;
- 30 - la figure 39 représente un dispositif de traitement d'un signal sonore selon l'invention ;
- la figure 40 est une représentation simplifiée d'un dispositif selon l'invention.

L'invention peut être l'objet de réalisations nombreuses. Les
35 informations exploitées peuvent être de natures variées et représenter des

données ou paramètres multiples. Toutefois, sa première application est le traitement d'images, celles-ci constituant l'espace considéré. Il est bien entendu, alors, à deux dimensions. La description détaillée qui suit correspond à ce mode de réalisation particulier.

5 L'unité de calcul d'histogramme 1 de l'invention est représentée dans son contexte par les figures 1 et 2.

Cette unité de calcul d'histogramme 1 fait partie d'une unité de perception visuelle 13 qui reçoit et exploite un signal $S(t)$ ou $S(PI)$. L'unité de calcul d'histogramme exploite et génère une information dite rétroannotation
10 $S'(t)$ sur un bus 111. Plus précisément, la figure 1 représente plusieurs unités de calcul d'histogramme 1A, 1B,..., 1E associées dans une même unité de perception visuelle.

Dans un mode de réalisation, l'unité de perception visuelle 13 traite différents signaux concernant une ou des scènes visuelles. Dans d'autres
15 modes de réalisation, l'unité de perception 13 traite d'autres paramètres de perception, par exemple des sons, des odeurs... La description qui suit concerne principalement la perception visuelle, l'adaptation à d'autres paramètres est possible.

Un séquenceur 9 génère, à partir de signaux de synchronisation ST, SL, CLOCK, des signaux de séquence INIT, WRITE et COUNTER qui
20 commandent les unités de calcul d'histogramme.

Tels que représentés sur la figure 1, les signaux d'entrée du séquenceur 9 (SL, ST, CLOCK) peuvent provenir d'un ensemble générateur de signaux 2 comportant une caméra 22 ou d'un ensemble générateur de
25 signaux 3 comportant un imageur CMOS 32.

Lorsque les signaux d'entrée proviennent d'un ensemble 2 comportant une caméra, cet ensemble impose des signaux de synchronisation de trames et de lignes de telle sorte que l'unité de calcul d'histogramme et son séquenceur 9 fonctionnent en mode esclave ou - synchronisation esclave -.

30 Au contraire, dans le cas où ces signaux proviennent d'un ensemble 3 comportant un imageur CMOS, le séquenceur 9 fonctionne en mode maître et génère lui-même les signaux de synchronisation.

Plus précisément, l'ensemble 2 permet l'acquisition de données provenant d'une scène 21 par une caméra 22. La caméra 22 produit un signal

S(PI) dont la forme, du type de celle représentée sur la figure 2, sera décrite en détail plus loin.

L'unité électronique de commande 23 de la caméra 22 fournit alors les signaux S(t) résultant de l'extraction des signaux de synchronisation de S(PI),
5 ST, SL et le signal d'horloge CLOCK issu d'une boucle à verrouillage de phase, qui sont utilisés par l'unité de calcul d'histogramme.

Dans le cas d'un ensemble 3 comportant un imageur CMOS, cet imageur 32 est utilisé pour l'acquisition de données de la scène 31, il fournit S(t) et est piloté par une unité de synchronisation 33 qui produit les signaux
10 de synchronisation de trames ST et de synchronisation de lignes SL, ainsi que le signal d'horloge CLOCK utilisé aussi bien par l'imageur CMOS 32 que par les autres éléments de l'unité de perception visuelle 13.

Les unités de calcul d'histogramme 1 sont avantageusement coordonnées à une unité de traitement spatial 6 et temporel 5 qui a été
15 décrite dans la demande de brevet WO-98/05002, et à une ligne à retard 7. L'unité de traitement spatial et temporel 5, 6 correspond au dispositif référencé 11 dans la demande de brevet citée. Il reçoit le signal S(PI) et génère des paramètres V (vitesse), DI (direction) correspondant chacun à l'une des données identifiées par DATA(A)... DATA(E) dans la présente
20 demande.

Ces paramètres peuvent aussi être la résolution spatiale, la structure de l'image (variation du contraste multi-échelle en coordonnées polaires...), tels qu'ils résultent d'une analyse par ondelettes de Gabor et décrits dans
l'article de Daugman, 1988, Complete Discrete 2D Gabor Transform..., IEEE
25 Trans. Acoust. Speech Signal Process, 36 :1169-1179.

Cet ensemble, constitué par une unité de calcul d'histogramme 1, l'unité de traitement spatial et temporel 5, 6 et la ligne à retard 7, fournit soit des informations, généralement sous forme numérique, dites - de
rétroannotation - exploitables par un dispositif aval, soit un signal permettant
30 la visualisation des informations sur un écran 8 par l'intermédiaire du bus 111.

Une unité de calcul d'histogramme passive (non autoadaptative) et sans anticipation est représentée sur la figure 3.

Cette unité de calcul d'histogramme est destinée à traiter les valeurs
35 d'un paramètre A qui sont affectées à chaque pixel dans un signal

$S(t) = \{a_{ijT}\}$ de type vidéo

Plus précisément, on appelle - signal S de type vidéo - un signal qui est composé d'une succession de trames, chaque trame consistant en une succession de pixels dont l'ensemble forme un espace, par exemple une
 5 image pour un espace à deux dimensions. Dans ce cas, les trames sont elles-mêmes décomposées en lignes et colonnes. Ce signal S(t) porte une valeur a_{ij} du paramètre A pour chacun des pixels (i,j). La succession des trames représente donc la succession d'images dans le temps. Dans la notation $\{a_{ijT}\}$, T représente la trame, i est le numéro d'une ligne dans la trame T, j est le
 10 numéro de la colonne du pixel dans cette ligne, a est la valeur du paramètre A associée au pixel ijT.

Le signal S peut être un signal analogique. Toutefois, il est de préférence numérique et composé, tel que représenté sur la figure 2 d'une succession de trames T_1 et T_2 , chacune étant formée d'une succession de
 15 lignes horizontales balayées telles que $l_{1,1}, l_{1,2}, \dots, l_{1,17}$ pour T_1 et $l_{2,1} \dots$ pour T_2 . Chaque ligne consiste en une succession de pixels ou de points-images PI.

S(PI) comprend un signal (ST) de synchronisation de trames au début de chaque trame, un signal (SL) de synchronisation de lignes au début de chaque ligne qui n'est pas également un début de trame. Ainsi, S(PI)
 20 comprend une succession de trames qui représente le domaine temporel et, à l'intérieur de chaque trame, une série de lignes et de pixels en colonnes qui sont représentatifs du domaine spatial.

Dans le domaine temporel, " des trames successives " désignent des trames se succédant dans le temps et " des pixels successifs à la même
 25 position " désignent les valeurs successives a_{ij} associées respectivement aux pixels (i, j) placés au même endroit dans les trames successives, c'est-à-dire par exemple (1, 1) de $l_{1,1}$ dans la trame T_1 et (1, 1) de $l_{2,1}$ dans la trame suivante correspondante $T_2 \dots$

A partir du S(PI), tel qu'indiqué plus haut par référence à la demande
 30 PCT/FR-97/01354, l'unité de traitement spatial 6 et temporel 5 génère un ou plusieurs signaux DATA(A)... DATA(E).

L'unité de calcul d'histogramme passive et sans anticipation, telle que représentée sur la figure 3, exploite un signal DATA(A) dont la structure est représentée sur la figure 2. Ce signal peut provenir soit directement d'une
 35 caméra ou d'un système quelconque d'acquisition d'images, ou avoir

préalablement subi un premier traitement, par exemple un traitement spatial et/ou temporel.

Elle génère un signal 101s de même structure qui porte pour chaque pixel une information significative du résultat de l'application des critères de reconnaissance ou de sélection.

Tel que représenté sur la figure 3, l'unité de calcul d'histogramme 1 comporte une mémoire d'analyse 100, un multiplexeur d'adresses 105, un multiplexeur d'entrées de données 106, une unité de validation d'incréméntation 107, un classifieur 101, une unité de rétroannotation 102 et une unité de test 103 dont les fonctionnements seront décrits plus loin.

L'ensemble des éléments constituant l'unité de calcul d'histogramme sont commandés et synchronisés par un signal d'horloge (clock).

I. La mémoire d'analyse 100

Cette unité de calcul d'histogramme 1 comporte une mémoire d'analyse 100.

Cette mémoire d'analyse 100 est de préférence une mémoire numérique classique synchrone ou asynchrone telle qu'une DRAM ou une SDRAM. Cette mémoire a un nombre n d'adresses d égal au nombre de niveaux possibles pour les valeurs du paramètre A qui doivent être discriminées.

Chacune de ces adresses peut stocker au moins le nombre de pixels contenu dans une trame (c'est-à-dire dans une image).

A chaque trame, après une remise à zéro rapide par le signal de commande INIT, un signal WRITE valide, pendant toute la trame, le traitement de la donnée DATA(A). Ainsi, la mémoire d'analyse 100 est susceptible de recevoir le signal DATA(A). Pour chaque trame reçue, les pixels pour lesquels la valeur du paramètre A a une valeur $a_{ij} = d$ (s'ils sont validés par le signal de validation 102s qui sera décrit plus loin), incrémentent le contenu de l'adresse de rang d de la mémoire 100 d'une valeur 1. Ainsi, après avoir reçu une trame complète, la mémoire 100 comporte, à chacune de ses adresses d , le nombre de pixels qui sont validés et pour lesquels le paramètre A a une valeur d .

II. Les multiplexeurs d'adresses et d'entrées de données

L'unité de calcul d'histogramme 1 comprend aussi un multiplexeur d'adresses 105, un multiplexeur d'entrées de données 106.

Chacun de ces multiplexeurs comporte une commande de sélection
5 binaire, deux entrées et une sortie.

La sortie du multiplexeur a pour valeur celle de l'une des entrées lorsque la commande de sélection vaut 1 et l'autre lorsqu'elle vaut zéro.

Lorsque le signal de commande INIT est égal à zéro, le multiplexeur
10 d'adresses 105 sélectionne une adresse dans la mémoire d'analyse 100 en fonction du niveau d du signal (a_{iT}) reçu, le multiplexeur d'entrées de données 106 transfère l'incrément de la valeur contenue dans cette mémoire en fonction de l'état de sa commande de sélection.

Lorsque le signal de commande INIT est égal à 1, le multiplexeur
15 d'adresses 105 transfère le signal du compteur qui incrémente l'adresse de zéro à la valeur maximum de DATA(A). Le multiplexeur d'entrées de données 106 force zéro sur l'entrée de la mémoire 100.

III. L'unité d'incrément

L'unité de calcul d'histogramme comporte également une unité
d'incrément 107.

20 Il s'agit d'un incrémenteur commandé comportant une entrée, une commande et une sortie.

La sortie de l'unité d'incrément est égale à la sortie de la mémoire d'analyse 100 si le signal de validation 102s est égal à zéro, elle est égale à cette même valeur augmentée de 1 dans le cas contraire.

25 IV. Le classifieur

L'unité passive de calcul d'histogramme comporte également un classifieur passif 101 qui comporte un registre 101r susceptible de mémoriser certaines des valeurs de niveaux possibles (d_1, d_2, \dots) des niveaux du paramètre A.

30 Le classifieur 101 reçoit le signal DATA(A) et effectue un tri des pixels fournissant, sur sa sortie 101s, une valeur 1 lorsque le paramètre A associé audit pixel a un niveau correspondant à celui contenu dans le registre 101r (d_1, d_2, \dots) et la valeur zéro dans le cas contraire.

La sortie du classifieur 101 est reliée à un bus 111.

V. L'unité de rétroannotation

L'unité de calcul d'histogramme comporte encore une unité de rétroannotation 102.

- 5 Cette unité de rétroannotation 102 est reliée au bus 111. Elle comporte au moins un registre 102r et reçoit pour chaque pixel des signaux DATA(A), les valeurs $(in_E, \dots, in_B, in_A)$ de sortie des classifieurs 101 des différentes unités de calcul d'histogramme auto-adaptatives reliées au bus 111.

- 10 Cette unité de rétroannotation compare les valeurs ainsi reçues à celles contenues dans son registre 102r et émet, sur sa sortie 102s, pour chaque pixel, un signal de validation égal à 1 lorsqu'il y a coïncidence entre les valeurs du registre égales à 1 et les données correspondantes reçues du bus 111, et une valeur zéro dans le cas contraire, ce qui correspond à la fonction booléenne suivante :

15
$$\text{out} = (\overline{in_0} + \text{Reg}_0) \cdot (\overline{in_1} + \text{Reg}_1) \dots (\overline{in_n} + \text{Reg}_n) (in_0 + in_1 + \dots in_n)$$

VI. L'unité de test et le registre de sortie d'analyse

L'unité de calcul d'histogramme comprend également une unité de test 103 recevant les informations sortant de la mémoire d'analyse 100 et reliée à des registres de sortie d'analyse 104.

- 20 Les registres de sortie d'analyse 104 sont destinés à recevoir des informations statistiques élaborées sur les valeurs du paramètre A du signal DATA(A) pour chaque trame.

- 25 Il peut s'agir par exemple des valeurs minimum (MIN) et maximum (MAX) du paramètre A, du nombre d'occurrences (RMAX) de la valeur la plus représentée et de la position (POSRMAX) de cette valeur, ainsi que du nombre (NBPTS) de points pour lesquels des informations ont été reçues.

L'unité de test 103 met à jour les registres de sortie d'analyse 104 en fonction des informations qu'il reçoit.

- 30 L'unité de validation d'incrémentation 107 produit également en sortie un signal adressé sur l'unité de test 103 lui permettant d'incrémenter le registre de sortie d'analyse 104 dans l'hypothèse favorable.

On comprend ainsi qu'après l'exploitation d'une trame complète, l'unité de calcul d'histogramme 1 a produit des informations statistiques

représentatives de cette trame, disponibles dans le registre de sortie d'analyse 104 et exploitables à toutes fins utiles, soit pour une visualisation accessible à l'opérateur, soit pour exploitation par tout autre programme ou automate.

- 5 Les registres de sortie d'analyse 104 comportent des mémoires pour chacune des caractéristiques-clés qui incluent le minimum (MIN) de l'histogramme, le maximum (MAX) de l'histogramme, le nombre de points (NBPTS) de l'histogramme, la position (POSRMAX) du maximum de l'histogramme et le nombre de points (RMAX) au maximum de l'histogramme.
- 10 Ces caractéristiques sont déterminées en parallèle avec la formation de l'histogramme par l'unité de test 103, de la manière suivante :
- Pour chaque pixel qui est validé :
- (a) si la valeur du paramètre DATA(A) du pixel < MIN (qui est initialement fixée à la valeur maximale de DATA(A) possible de l'histogramme), alors la valeur du paramètre est inscrite dans MIN ;
- 15 (b) si la valeur du paramètre DATA(A) du pixel > MAX (qui est initialement fixée à la valeur minimale de DATA(A) possible de l'histogramme), alors la valeur du paramètre est inscrite dans MAX ;
- (c) si le contenu de la mémoire 100 à l'adresse de la valeur du paramètre du pixel > RMAX (qui est initialement fixée à la valeur minimale DATA(A) possible de l'histogramme), alors i) écrire la valeur du paramètre dans POSRMAX et ii) écrire la sortie de la mémoire dans RMAX ;
- 20 (d) augmenter NBPTS (qui est initialement fixé à la valeur zéro) d'une unité.

25 VII. Fonctionnement d'ensemble de l'unité de calcul d'histogramme passive.

Plusieurs unités de calcul d'histogramme 1A, 1B...1E sont donc reliées au même bus de rétroannotation 111. La présente description est faite en référence à cinq unités de calcul d'histogramme A à E. On comprend que la

30 généralisation à un nombre quelconque d'unités peut être faite.

A. Signal WRITE

Pendant chaque signal WRITE, chacune d'elles fournit au bus, pour chaque pixel, le signal de sortie 101s de son classifieur 101 et elles reçoivent

chacune l'ensemble de ces signaux sur l'entrée in_A, \dots, in_E de leur unité de rétroannotation 102.

La valeur du paramètre, par exemple DATA(A) pour l'unité 1A, est comparée au contenu du registre 101r du classifieur 101. Le résultat
 5 $in_A = 101s$ de cette comparaison est un signal binaire qui est adressé en même temps que ses homologues $in_B \dots in_E$ provenant des autres unités 1B...1E.

L'unité de rétroannotation 102 compare ces valeurs prises ensemble au contenu de son registre 102r constituant un critère R de rétroannotation et
 10 génère, sur sa sortie 102s, un signal binaire dont la valeur dépend du résultat de la comparaison.

Ce signal 102s commande l'incrémenteur 107. Lorsqu'il est égal à 1, il produit, par l'intermédiaire du multiplexeur de données 106, l'incrémementation d'une unité du contenu du registre de la mémoire 100 correspondant à la
 15 valeur du paramètre DATA(A), simultanément l'unité de test 103 assure l'exploitation statistique du contenu de la mémoire 100 et en transfère le contenu dans le registre de sortie d'analyse 104.

A la fin du signal WRITE, les registres de la mémoire 100 contiennent chacun pour valeur d, le nombre de pixels pour lesquels le signal DATA (A)
 20 avait la valeur d correspondante et que l'unité de rétroannotation a validé.

B. Signal INIT

Pendant le signal INIT, le signal COUNTER qui balaie les valeurs de 0 à n, assure la remise à zéro des registres de la mémoire 100.

VIII. L'auto-adaptation

25 Dans la description faite jusqu'à présent, la mémoire du classifieur 101 est un registre 101r dont le contenu déterminé de l'extérieur du système est fixe. Ce classifieur est alors dit passif.

L'autoadaptation consiste en l'actualisation automatique, par le système lui-même, du contenu de la mémoire du classifieur, ce contenu étant
 30 alors une table de transcodage (LUT - Look Up Table). On obtient ainsi une unité de calcul d'histogramme 1 autoadaptative.

Pour assurer la fonction d'autoadaptation, c'est-à-dire de mise à jour en temps réel du classifieur, l'unité de calcul d'histogramme de la figure 3 est perfectionnée conformément à la figure 4.

Au lieu d'avoir un simple registre 101r écrit de l'extérieur du système, le classifieur 101 a une mémoire adressable dont l'écriture est commandée par un signal END.

Le séquenceur 9 génère ce signal END représenté sur la figure 5.
 5 L'unité de calcul d'histogramme comporte un opérateur de sélection OU 110 recevant en entrée les signaux INIT et END et relié en sortie à la commande du multiplexeur d'adresses 105.

La mémoire du classifieur 101 est commandée par le système lui-même. Son contenu est modifiable, elle comporte une entrée de données
 10 DATA IN, une commande d'écriture WR et une entrée d'adresses ADRESS.

Cette entrée d'adresses est reliée à la sortie d'un multiplexeur d'anticipation 108. Ce multiplexeur 108 de type "deux vers un" comporte une commande d'anticipation reliée à la sortie d'un opérateur OU 112 recevant en entrée les signaux INIT et END.

15 Les entrées du multiplexeur d'anticipation reçoivent les mêmes signaux que les entrées du multiplexeur d'adresses 105 (DATA(A) et COUNTER).

Lorsque le signal END vaut 1, la mémoire du classifieur est écrite par un signal résultant de la comparaison entre la valeur de la mémoire 100 d'histogramme et une valeur issue du registre de sortie d'analyse 104
 20 (RMAX/2) pour toutes les valeurs possibles de DATA(A)).

A. Classifieur premier mode de réalisation

En référence à la figure 12, le classifieur 101 assurant l'autoadaptation comporte une mémoire 118 dont l'entrée d'écriture WR reçoit le signal END, l'entrée d'adresses ADRESS reçoit le signal de sortie du multiplexeur
 25 d'adresses 108. Il comporte de plus un comparateur 119 comportant deux entrées et une sortie, celle-ci étant reliée à l'entrée de données DATA IN de la mémoire 118.

La première entrée du comparateur 119 reçoit la valeur RMAX/2 produite par un registre de sortie d'analyse 104 et, sa deuxième entrée reçoit
 30 la sortie de la mémoire 100.

Le fonctionnement de la mémoire 118 du classifieur est alors le suivant.

Elle comporte le même nombre de mots que la mémoire d'analyse 100 mais dans la mémoire 118, chaque mot ne comporte qu'un seul bit.

A la fin (signal END = 1) de la réception d'un nouveau flux de données DATA(A) d'une trame, une séquence d'écriture commence.

Lorsque pour une mémoire donnée d de la mémoire d'analyse 100, la valeur lue est supérieure à $RMAX/2$, une valeur 1 est inscrite dans la mémoire
 5 118 à la position correspondante. Dans le cas contraire, la valeur 0 est inscrite à cette position. L'ensemble des mémoires d est balayé de 0 à n. La mémoire 118 du classifieur 101 a ainsi été mise à jour.

B. Classifieur second mode de réalisation

La figure 13 représente un mode de réalisation alternatif du classifieur
 10 dans lequel un multiplexeur 120 est commandé par une commande de choix 124 et permet la comparaison du paramètre P à une valeur statistique Q, qui peut être élaborée de différentes manières en fonction des paramètres statistiques reçus sur ses différentes entrées 0, 1, 2, 3 qui sont sélectionnées par la commande de choix 124. La commande de choix dépend du contenu
 15 du registre " CHOIX ". L'entrée 0 du multiplexeur 120 reçoit la valeur $RMAX/2$ produite à partir des données du registre de sortie d'analyse 104 par le diviseur par 2, 121, l'entrée 1 du multiplexeur 120 reçoit directement la valeur RMAX, l'entrée 2 du multiplexeur 120 reçoit une valeur de seuil contenu dans un registre " SEUIL " 123 dont le contenu est programmé de l'extérieur du
 20 système, l'entrée 4 de ce multiplexeur reçoit le quotient du nombre de points NBPTS par le SEUIL produit par le diviseur 122.

Donc tel que représenté sur la figure 13, le paramètre P peut être comparé aux valeurs respectives $RMAX/2$, RMAX, à un seuil B entré depuis l'extérieur et au rapport du nombre de points NBPTS rapporté à ce seuil par
 25 le diviseur 122.

Le contenu de la mémoire 118 est mis à jour, en fonction des signaux fournis par le comparateur 119 de manière analogue à la mise à jour décrite dans le premier mode de réalisation.

IX. La mémoire 118 du classifieur 101

30 La figure 16 est une représentation détaillée de la mémoire 118 faisant apparaître un démultiplexeur avec validation d'entrée 130 et un multiplexeur de sortie 131. Le démultiplexeur d'entrée 130 recevant le signal d'écriture WR est donc à même de valider le choix du registre de la mémoire 118, sélectionné par la commande d'adresse ADRESS, pour l'écriture de la valeur

binaire de la comparaison DATA IN. Le multiplexeur 131 de sortie adresse la valeur d'un registre particulier, sélectionné par la commande d'adresse ADRESS, sur la sortie 101s de la mémoire 118 du classifieur.

5 Le démultiplexeur d'entrée 130 et le multiplexeur de sortie 131 sont commandés par le bus 134 issu du multiplexeur d'anticipation 108.

10 Plus précisément, le démultiplexeur 1/n d'entrée 130, commandé par l'adresse transmise par le bus 134, envoie le signal WR (WRITE), respectivement sous la forme des signaux Sel₀, Sel₁, Sel₂,..., Sel_n sur les registres 140₀, 140₁, 140₂,..., 140_n de rang 0, 1..., n et détermine celui de ces registres dans lequel le contenu de l'information transmise par le signal DATA IN est adressé. En sortie, les informations provenant de ces registres 140₀, 140₁, 140₂,..., 140_n sont adressées sur le multiplexeur 131 qui les dirige sur sa sortie OUT.

X. L'anticipation

15 Dans une forme de réalisation préférée, en plus de la mise à jour en temps réel, l'unité 1 de constitution d'histogramme assure une fonction d'anticipation.

20 Cette anticipation de l'autoadaptation du classifieur 101 améliore le fonctionnement de ce système bouclé et le rapproche d'un fonctionnement d'un système physiologique.

Le but de l'anticipation est, comme son nom l'indique, d'anticiper la valeur contenue dans la mémoire 118 du classifieur de façon à accélérer le traitement et, par là, à faciliter le suivi d'un objet ou de son évolution.

25 A cet effet on recourt d'abord à un calcul de la variation global de l'histogramme dont le résultat est, ensuite, utilisé pour appliquer l'anticipation selon l'une ou l'autre de deux méthodes.

A. Calcul de la variation globale de l'histogramme

30 L'unité de test 103 et les registres 104 de sortie d'analyse génère alors une valeur statistique POSMOY dont les valeurs POSMOY₀ et POSMOY₁ pour deux trames successives sont mémorisées. POSMOY est la valeur du paramètre DATA(A) par rapport à laquelle, dans une trame donnée, ledit paramètre a une valeur supérieure ou égale pour la moitié des points validés de la trame et une valeur inférieure pour l'autre moitié.

Préparation

Lorsque le signal END vaut 1, la nouvelle valeur POSMOY_o est calculée et la valeur précédente de POSMOY_o est sauvegardée en POSMOY₁.

5 POSMOY

En référence à la figure 14, on décrira maintenant l'élaboration de la variable POSMOY_o.

Cette variable POSMOY_o est produite par un comparateur 302.

10 Ce comparateur 302 reçoit, sur l'une de ses entrées Q, le paramètre NBPTS qui est divisé par deux par le diviseur 303.

Sa deuxième entrée P est alimentée par la sortie d'un registre 301 qui est commandé par les signaux d'initialisation INIT et de fin END, et reçoit en entrée la sortie d'un additionneur 300 qui reçoit lui-même en entrée, la valeur de sortie du registre 301 et sur sa deuxième entrée, la valeur de sortie de la
15 mémoire 100 qui a été précédemment décrite.

Ainsi, le registre 301, initialement remis à zéro, mémorise le cumul du contenu des registres de la mémoire qui sont balayés par le signal COUNTER de zéro à n.

20 Tant que ce cumul est inférieur à NBPTS/2, la valeur du COUNTER est mémorisée dans POSMOY_o. A la fin du cycle END, POSMOY_o contient donc la dernière valeur COUNTER pour laquelle le cumul est inférieur à NBPTS/2.

B. Application de la variation de l'histogramme à l'anticipation (1ère méthode)

25 Cette première méthode est représentée sur la figure 15. La mémoire 118 est celle décrite précédemment en référence à la figure 16.

Un automate 310 dit - unité de calcul de valeur absolue avec extraction de signe - fournit les valeurs $|\text{POSMOY}_o - \text{POSMOY}_1|$ et le signe de cette différence.

30 Ces paramètres commandent un translateur 311 après inversion du signe par l'inverseur 312.

La valeur du paramètre alimentant la mémoire 118 est ainsi décalée de la valeur $|\text{POSMOY}_o - \text{POSMOY}_1|$ par rapport au fonctionnement passif, dans le sens opposé à la variation de POSMOY calculée dans l'unité 310.

35 La figure 15a représente un circuit alternatif permettant la mise en œuvre de la première méthode d'application de la variation de l'histogramme

à l'anticipation. Dans ce mode de réalisation, l'unité de calcul 310a est analogue à l'unité de calcul 310 mais elle permet des possibilités plus souples de décalage de la valeur du paramètre fourni à la mémoire 118. Alors que l'unité de calcul 310 de la figure 5 produit un décalage déterminé par une

5 fonction de la forme $y = x$ où x est $(\text{POSMOY}_0 - \text{POSMOY}_1)$, l'unité de calcul 310a fournit un décalage déterminé par des fonctions de la forme $y = ax + b$, dans laquelle a (par exemple k_1 et k_2) et b (par exemple c_1 et c_2) sont des constantes ajustables qui peuvent être fournies par un processeur.

On comprend qu'ainsi, toute autre fonction agissant sur les valeurs

10 POSMOY peuvent être utilisées si voulu tel que $y = ax^2$. Sur la figure 15a, le multiplexeur 127 reçoit en entrée les deux fonctions de POSMOY, c'est-à-dire $k_1 \times (P_0 - P_1) + c_1$ et $k_2 \times (P_0 - P_1) + c_2$, et fournit une sortie fondée sur la valeur du signal de contrôle « CLOCK ».

Pour augmenter le domaine de classification, le circuit OU 125 et le

15 circuit de retard 126 peuvent être utilisés. Le circuit de retard est contrôlé par le même signal d'horloge qui contrôle le multiplexeur 127. Les valeurs de sortie de la mémoire 118 reliées aux deux fonctions différentes de décalage sont alors fournies à la porte OU 125 dont la sortie est le signal 102s avec un domaine de classification amélioré, ce qui améliore l'anticipation.

20 ***C. Application de la variation de l'histogramme à l'anticipation (2ème méthode)***

Cette deuxième méthode est représentée sur la figure 17. La mémoire 118 est alors celle représentée sur la figure 18.

L'architecture générale de la mémoire 118 est celle déjà décrite plus

25 haut. Nous décrivons une séquence pour 1 bit donnée, les autres étant analogues. Les éléments communs à la figure 16 portent les mêmes références.

Le registre 140_1 est associé à un multiplexeur d'entrées 2/1 160_1 qui reçoit sur l'une de ses entrées, le signal binaire sortant du comparateur 119

30 et sur l'autre de ses entrées, le signal de sortie de l'automate de calcul d'anticipation 150_1 .

Le multiplexeur d'entrée 160_1 est commandé par le signal ETD qui commande également l'écriture.

A cet effet, la commande d'écriture du registre 140_1 est reliée à un opérateur OU 170_1 qui reçoit, sur l'une de ses entrées, le signal ETD et sur l'autre, un signal Sel.

5 En sortie du registre 140_1 , un automate de calcul d'anticipation 150_1 reçoit en entrée les trois signaux Q_0 , Q_1 et Q_2 de sortie des registres 140_0 , 140_1 , 140_2 de rang respectivement 0, 1, 2, il est commandé par les signaux SM, SP et T.

Dans les automates 150_0 , $150_1, \dots$, l'anticipation est réalisée par la succession d'opérations de dilatation suivie d'opérations d'érosion.

10 L'automate de calcul d'anticipation 150 est décrit en détail sur la figure 19, il comporte un multiplexeur 207 comportant une sortie et deux entrées commandé par le signal T.

L'une de ses entrées est reliée à un opérateur de dilatation 208 qui fournit un signal A_1 et l'autre à un opérateur d'érosion 209 qui fournit un
15 signal B_1 .

L'opérateur de dilatation 208 comporte un circuit OU 201 à trois entrées et une sortie. Sa sortie est reliée au multiplexeur 207.

Sa première entrée est alimentée par le signal Q_1 , sa deuxième entrée est alimentée par la sortie d'un circuit ET 202 à deux entrées dont l'une des
20 entrées est le signal Q_0 et l'autre entrée est le signal SP. La troisième entrée du circuit OU 201 est alimentée par la sortie d'un circuit ET 203 à deux entrées, l'une de ces entrées étant le signal Q_2 et l'autre étant le signal SM.

La fonction réalisée par l'opération de dilatation 208 est ainsi

$$A_1 = Q_1 + Q_0 \times SP + Q_2 \times SM$$

25 L'opérateur d'érosion 209 comporte un circuit ET 204 à trois entrées et une sortie. Sa sortie est reliée au multiplexeur 207.

Sa première entrée est alimentée par le signal Q_1 .

Sa deuxième entrée est reliée à un circuit NON-ET à quatre entrées et une sortie 205.

30 La première entrée de ce circuit NON-ET 205 est reliée au signal SP, la deuxième au signal Q_1 . La troisième entrée est reliée au signal Q_0 et la quatrième inversée au signal Q_2 .

Un deuxième opérateur NON-ET 206 a quatre entrées et une sortie reliée à la troisième entrée du circuit ET 204, la première de ses entrées étant

alimentée par le signal Q_1 , la deuxième par le signal SM, la troisième par le signal Q_2 et la quatrième inversée par le signal Q_0 .

La fonction réalisée par l'opérateur d'érosion 209 est ainsi

$$5 \quad B_1 = Q_1 \times \overline{(SM \times Q_2 \times \overline{Q_0})} \times \overline{(SP \times \overline{Q_2} \times Q_0)}$$

Le fonctionnement de l'opérateur d'anticipation est illustré par la figure 20.

10 Sur cette figure, à gauche en référence à l'axe des temps t, sont représentés les signaux INIT, WRITE, END, ETD, T, SP, SM.

Le signal INIT généré par le séquenceur 9 démarre le cycle de traitement d'une trame. Pendant sa durée, tous les mémoires et registres sont initialisés.

15 Le signal WRITE également généré par le séquenceur 9 suit le signal INIT et commande les calculs statistiques pour la trame considérée dont les données sont représentées par la courbe C, dont les axes représentent en abscisse les valeurs du paramètre et en ordonnée le nombre d'occurrences.

L'unité de test 103 recherche le nombre d'occurrences maximum RMAX.

20 A la fin du signal WRITE, le signal END encore généré par le séquenceur 9 valide la mise à jour de la mémoire du classifieur 118. Les nouvelles données sont générées par le comparateur 119.

A la fin du signal END au temps t_0 , le contenu de la mémoire 118 est représenté par la répartition R_0 .

25 La fin du signal END démarre le signal ETD dont la durée est déterminée par le générateur de commande 313. Ce signal ETD valide le calcul de l'étendue dans la mémoire 118 du classifieur.

30 Les signaux SP (Sens Plus) et SM (Sens Moins) compris dans ETD commandent respectivement le traitement dans le sens positif ($SP=1$) et dans le sens négatif ($SM=1$) de l'étendue de la répartition R_0 qui devient R_1 à t_1 , R_2 à t_2 et R_3 à t_3 ...

Ainsi, les durées respectives de SP et SM déterminent l'étendue et la position de la répartition R_5 à la fin du signal ETD.

35 Le multiplexeur 207 commandé par la commande T ayant deux entrées alimentées respectivement par les sorties des opérateurs de dilatation et

d'érosion et une sortie permet de mettre en oeuvre l'un ou l'autre de ces opérateurs en fonction de la commande T.

La sortie du multiplexeur 207 est OUT_1 ,

$$5 \quad OUT_1 = A_1 \times \bar{T} + B_1 \times T$$

XI. La rétroannotation

Dans un mode de réalisation simplifié décrit jusqu'à présent, le bloc de rétroannotation 102 comporte un seul registre contenant une seule valeur de rétroannotation constituant le critère R de rétroannotation.

10 **A. Critères complexes de rétroannotation**

Dans un mode de réalisation préféré, le bloc de rétroannotation est une mémoire pouvant contenir plusieurs valeurs formant ensemble le critère R de rétroannotation, l'une ou l'autre d'entre elles pouvant valider l'information portée par un pixel. Chacune de ces valeurs est mise en mémoire dans un
15 registre terme produit 410.

La figure 22 représente un tel bloc de rétroannotation 102 dans son ensemble. Il est composé d'un ensemble de termes produits 410 alimentés par le bus 425 A « PRODUCT TERM » et commandés par le bus Programm Register 12.

20 Chacun de ces termes produits 410 a une sortie qui alimente un opérateur OU 421 qui fournit lui-même en sortie un signal entrant sur l'une des entrées d'un inverseur commandé 422, qui reçoit sur sa deuxième entrée les signaux provenant du bus Programm Register 12 par l'intermédiaire du registre 423.

25 Les figures 23 et 24 illustrent une unité mémoire (FPGA - Field Programmable Gate Area) reprogrammable 400 mise en oeuvre pour la réalisation de l'unité de rétroannotation 102.

Une telle mémoire comporte un inverseur commandé 403 dont la sortie est la sortie de l'unité reprogrammable 400 et dont l'une des entrées est un
30 opérateur OU 401 relié aux B lignes 405, ces lignes coupant les A colonnes 406 qui sont reliées à des amplificateurs 402 fournissant des signaux s et \bar{s} .

Les intersections 404 des lignes 405 et des colonnes 406 sont des connexions programmables permettant de déterminer l'ensemble du fonctionnement de l'unité reprogrammable 400.

5 La figure 24 représente une ligne unique 410 d'une telle unité reprogrammable 400.

Une telle ligne comporte des registres 411 et 412 destinés à recevoir des variables Reg-a0 et Reg-b0 de programmation.

10 Cette ligne est décomposable en A fonctions élémentaires dont chacune comporte un inverseur commandé 413, un opérateur OU 415 et un inverseur 414. L'une des entrées de l'inverseur commandé 413 est reliée à l'entrée A et l'autre de ces entrées au bit i du registre Reg-a0.

La sortie de cet inverseur commandé 413 est reliée à l'entrée de l'inverseur 414 qui alimente, par sa sortie, l'une des entrées de l'opérateur OU 415.

15 L'autre entrée de cet opérateur OU 415 est alimentée par le bit i du registre Reg-b0.

20 La sortie de l'inverseur commandé 413 alimente également l'une des entrées d'un opérateur OU 417 qui reçoit encore l'ensemble des signaux correspondants produits par les différentes sorties des fonctions élémentaires.

Un opérateur ET 416 dont la sortie est product term0 reçoit en entrée d'une part la sortie de l'opérateur OU 417 et d'autre part les sorties des différentes fonctions élémentaires.

B. L'apprentissage

25 Le bloc de rétroannotation peut être programmé de l'extérieur par une instruction d'une interface de gestion d'application. Cette interface charge les registres 411 et 412.

30 Dans un mode de réalisation encore préféré, l'unité 1 de constitution d'histogramme, en plus de la mise à jour du classifieur et de l'anticipation a une fonction d'apprentissage.

A cet effet, l'unité 1 de constitution d'histogramme comporte un multiplexeur d'apprentissage 108 qui permet la programmation automatique de l'unité de rétroannotation 102.

35 Le multiplexeur d'apprentissage 108 sélectionne l'un ou l'autre des deux modes de fonctionnement possibles (exploitation et apprentissage). En

mode d'exploitation, les valeurs contenues dans le registre de l'unité de rétroannotation 102 sont fixées, au contraire, en mode d'apprentissage, ces valeurs sont mises à jour.

Le mode d'exploitation

5 Lors du fonctionnement en mode d'exploitation, le multiplexeur d'apprentissage 109 émet, sur sa sortie, un signal de valeur 1 signifiant que les valeurs contenues dans les registres du bloc de rétroannotation 102 ne sont pas modifiées pendant la séquence de fonctionnement en mode d'exploitation.

10 Les valeurs stockées dans ces registres ont donc soit été choisies et mises en mémoire par l'utilisateur, soit ont résulté d'une phase d'apprentissage préalable que nous analyserons plus loin.

L'unité de rétroannotation 102 reçoit également, des autres unités de calcul d'histogramme coopérant avec celle décrite ici, des signaux comparables inE...inA.

Remplissant son rôle déjà décrit plus haut, cette unité de rétroannotation compare les valeurs ainsi reçues aux valeurs mises en mémoire dans son ou dans ses registre(s) et produit en sortie un signal 102s égal à 1 en cas de coïncidence et à zéro dans le cas contraire. Ce signal de validation est adressé à l'unité de validation d'incrément et lorsque sa valeur est égale à 1, autorise la prise en compte de la valeur du paramètre DATA(A) du pixel concerné dans la mémoire d'analyse 100 et, dans le cas contraire, autorise le traitement du pixel suivant.

Le mode d'apprentissage

25 Le fonctionnement de l'unité de calcul d'histogramme est alors commandé par des signaux représentés sur la figure 5, c'est-à-dire un signal d'initialisation (INIT), un signal d'écriture (WRITE), qui portent les informations correspondant à chaque pixel de la trame (ou de l'image) et un signal de fin END.

30 Dans le mode d'apprentissage, le multiplexeur d'apprentissage 109 fournit en sortie la valeur du signal de rétroannotation qui est alors utilisée comme donnée DATA(A).

Lors de l'apprentissage d'une unité de calcul d'histogramme de rang i, un signal LEARN_i valide durant toute une séquence trame le traitement en mode apprentissage.

Pendant cette séquence, les registres d'apprentissage 116 sont mis à jour. Simultanément, le bloc de rétroannotation 102 assure la transparence des signaux, validant la donnée DATA(A), alors égale au signal de rétroannotation 111 dès qu'une au moins des entrées inA,..., in E est active (=1).

A la fin du signal WRITE, la mémoire d'histogramme 100 représente la distribution du signal de rétroannotation.

L'unité de test 103 produit alors un classement des occurrences par valeur décroissante en nombre égal au B « SUM TERM ».

Pendant le signal END, les valeurs du signal de rétroannotation ainsi sélectionnées sont écrites dans les registres 411 et 412 de chacun des blocs 410 du bloc de rétroannotation 102.

Le registre 412 correspond à la valeur du signal de rétroannotation et le registre 411 correspond à son complément. En pratique, on peut utiliser deux sorties d'un même registre fournissant ces deux valeurs.

On réalise ainsi une élaboration statistique automatique des paramètres caractéristiques dans la trame étudiée.

Ainsi, l'apprentissage nécessite, pour n paramètres d'entrée, n+1 unités calcul d'histogramme. Les n blocs traitant l'un des paramètres et le bloc restant traitant l'information de rétroannotation pour assurer l'apprentissage. En pratique, l'information de rétroannotation ayant un nombre de digits important, l'unité d'apprentissage est dédiée et est de grande dimension.

Les organigrammes des différents logiciels requis pour assurer les fonctions d'autoadaptation, d'anticipation et d'apprentissage représentés sur les figures sont lisibles en eux-mêmes et ne nécessitent pas d'explications complémentaires pour être compris de l'homme du métier. Lorsque, de manière interne, ils font appel à des variables, celles-ci ont été représentées dans un cadre. Certaines fonctions étant réalisées dans un composant particulier décrit par ailleurs, la référence numérique de ce composant a aussi été affectée à la fonction.

synchrone. Ce sont de préférence des signaux numériques. Le signal complexe F comprend alors un certain nombre de signaux de sortie générés par le système comprenant de préférence des signaux signifiant la présence et la localisation d'une zone ou d'un objet en mouvement, la vitesse V est la direction orientée du déplacement DI de chaque pixel de l'image. Egalement, de préférence, une sortie du système est constituée par le signal vidéo numérique d'entrée qui est retardé (SR) de façon à le synchroniser avec la sortie ZH de la trame, en prenant en compte le temps de calcul du signal de données composite F (pour une trame). Le signal retardé SR est utilisé pour représenter l'image reçue par la caméra sur un moniteur ou un écran de télévision qui peut aussi être utilisé pour représenter l'information contenue dans le signal composite ZH. Le signal composite ZH peut aussi être transmis à une unité de traitement distincte 10a qui poursuit le traitement de ce signal.

XIII. Traitement spatial : Choix d'axes

La position d'un pixel dans l'espace est représentée par rapport à un système d'axes. Selon la forme, l'orientation,... des objets dans la scène, certains systèmes d'axes fournissent de meilleurs résultats que les autres.

Les figures 26 et 27 présentent le procédé de choix des axes permettant d'obtenir des histogrammes optimisés, c'est-à-dire présentant un maximum particulièrement marqué.

L'unité Space transform reçoit en entrée les données spatiales x, y qui peuvent être soit des données cartésiennes, soit des données polaires. Cette unité Space transform est commandée par un signal α et fournit en sortie, pour chacune des valeurs de α , un paramètre qui alimente une unité de constitution d'histogramme selon l'invention.

Le programme de commande de cette unité d'histogramme introduit par le Programm Register permet de sélectionner la valeur α produisant un histogramme optimisé.

Un tel procédé de choix des axes a été décrit en détail dans la demande PCT WO-98/05002 (voir la figure 11 et la description correspondante, l'unité « Space Transform » y étant référencée 37).

XIV. Traitement temporel

Au traitement colorimétrique qui exploite les valeurs des signaux de teinte, de saturation et de luminance, aux signaux de vitesse, direction et intensité, on peut adjoindre une fonction de filtrage spatial produisant un
 5 paramètre de résolution spatiale (méthode de Gabor) et une fonction binoculaire qui, par un automate de calcul de distance, fournit un paramètre de profondeur.

Des applications complètes peuvent être réalisées en exploitant tout ou partie de l'ensemble de ces paramètres.

10 XV. Visu courbe statistique

Dans un mode de réalisation préféré, un générateur de courbe 114 permet l'incrustation à l'écran d'une courbe des valeurs DATA pour la trame antérieurement traitée.

De même, une incrustation du signal de rétroannotation est possible.

15 Ces incrustations sont adressées respectivement par les lignes 14 et 15 vers un écran. Des interrupteurs 16 et 17 permettent de sélectionner une unité de calcul d'histogramme particulière parmi l'ensemble de celles-ci.

Les figures 28 et 29 décrivent plus précisément les moyens de visualisation de la courbe d'histogramme.

20 La mémoire 100 adressée par la valeur du compteur de colonnes 353 alimente l'une des entrées d'un registre à décalage 350 dont l'autre entrée est alimentée par le paramètre RMAX produit par le registre d'analyse 104.

La sortie de ce registre à décalage 350 alimente l'une des entrées d'un comparateur 351 dont l'autre entrée est alimentée par un compteur de lignes
 25 352 au travers d'un inverseur 354. Un opérateur ET 355 recevant, d'une part, le résultat de la comparaison $P \geq Q$ et, d'autre part, la variable Val_Zone, fournit en sortie la variable Aff_Cbe.

Le compteur de colonnes 353 qui génère les variables « Col-Counter » 356 et « Col_Curve_Counter » 357, le compteur de lignes 352 qui génère les
 30 variables « Row_Curve_Counter » 358 et « Row_Counter » 359 et le générateur de la variable Val_Zone sont un sous-ensemble 91 du séquenceur 9.

De plus, le bloc de commande de visualisation 365 de l'écran 8 reçoit le signal vidéo retardé SR, une commande de curseur produite par le bloc curseur 366, une commande produite par la mémoire semi-graphique 367.

La figure 29 est le résultat de la vignette obtenue 360 validé par le commutateur 16 qui transfère le signal d'affichage courbe sur la commande d'incrustation 15 dans l'écran 361 qui comporte de plus une zone de commande 362, un curseur 363 et une zone texte 364.

Ainsi, cet écran et la souris associée constituent une interface graphique utilisateur (GUI) permettant à l'utilisateur de générer et de commander l'application.

De même, la fonction de rétroannotation peut être visualisée, en dynamique, sous forme de pixels 365, par commutation du commutateur 17 sur la commande d'incrustation de la rétroannotation 14.

XVI. APPLICATIONS

Sur les figures 30 et suivantes, on a représenté la mise en œuvre d'un ensemble d'unités de calcul d'histogramme permettant la gestion d'un nombre aussi grand que nécessaire de paramètres A, B, C, D, E... L'association de paramètres à la fois spatiaux (en principe au nombre de deux) et temporels (au moins un) permet de modéliser un neurone spatio-temporel. Les unités de traitement respectivement temporelles 5 et spatiales 6 reçoivent d'une part le signal $S(t)$, d'autre part les signaux horloge CLOCK et de synchronisation ST, synchronisation de trames et SL, synchronisation de lignes.

Tel que représenté sur les figures 4 et 30, chacun des paramètres A, B, C, D, E... sortant de ces unités de traitement temporel 5 et spatial 6 alimente une unité de calcul d'histogramme, respectivement $1_A, 1_B, \dots, 1_E$. La rétroannotation produite par l'ensemble des classifieurs est disponible sur le bus 111 et utilisée dans son ensemble par chacune des unités de calcul d'histogramme, respectivement $1_A, 1_B, \dots, 1_E$.

A titre d'exemple, A, B, C, ..., E peuvent représenter respectivement les composantes couleur du pixel d'entrée sous la forme luminance L, teinte T et saturation S. D et E seraient les coordonnées P_1 et P_2 du pixel considéré dans un système d'axes optimisé.

Dans le mode de réalisation de la figure 31, les différents paramètres DATA(A)... DATA(E) alimentent un multiplexeur d'entrée 500 qui est commandé par un registre 501. Le registre 501 est mis à jour par la commande SELECT référencée 502. Le multiplexeur commandé
 5 d'apprentissage 503 reçoit, selon l'état de la commande d'apprentissage de l'unité de calcul d'histogramme i , LEARN $_i$, soit l'information de rétroannotation transmise par le bus 111, soit les informations provenant du multiplexeur d'entrée 500.

Il est ainsi possible d'utiliser une seule unité de calcul d'histogramme 1
 10 pour traiter l'un quelconque des différents paramètres A, B, C,..., E qui lui sont adressés par un bus 510 en fonction de la commande SELECT.

Selon l'état de la commande d'apprentissage LEARN, l'unité de calcul d'histogramme fonctionnera soit en exploitation, soit en apprentissage.

L'ensemble 1a ainsi formé par une unité de calcul d'histogramme 1, un
 15 multiplexeur d'entrée 500, son registre associé 501, et éventuellement un multiplexeur d'apprentissage constitue une unité de calcul d'histogramme polyvalente.

La figure 32 représente un dispositif complet comprenant à titre
 20 d'exemple un ensemble de seize unités de calcul d'histogramme polyvalentes.

Ces unités constituent une matrice, elles sont reliées à un bus 510 sur lequel les paramètres D, V, S, T, L, p_0 , p_1 , p_2 ,..., p_{15} sont disponibles (p_0 , p_1 , p_2 ,..., p_{15} sont des pentes d'axes de référence). Le bus 111 porte l'information de rétroannotation.

L'ensemble de l'application est commandé par l'unité de contrôle 513
 25 qui détermine ceux des paramètres L, T, S, V, D, p_0 , p_1 ,... p_{15} qui sont traités à un instant donné par une ou un groupe d'unités d'histogramme polyvalentes dédié et, par le séquenceur 9.

La figure 40 représente un diagramme fonctionnel d'un ensemble
 30 comportant plusieurs unités de calcul d'histogramme (tel que représenté sur la figure 31) conformément à un mode de réalisation de la présente invention. Chaque unité 1a de calcul d'histogramme est reliée à un bus de données 510 qui fournit les différents paramètres à traiter, et à un bus 11 qui fournit le signal de classification 101s et les signaux de fonction d'apprentissage aux
 35 différentes unités 1a. Chaque unité de calcul d'histogramme comporte une

mémoire 100, un classifieur 101 et une unité de rétroannotation 102. Chaque unité 1a est susceptible d'avoir des fonctions de classification automatique d'anticipation et d'apprentissage telles que décrites plus haut.

5 L'ensemble d'unités de calcul d'histogramme 1 peut fonctionner en mode de traitement pendant qu'une ou plusieurs d'entre elles sont en mode d'apprentissage.

10 Dans un mode de réalisation particulier, une unité de calcul d'histogramme est utilisée en temps partagé par plusieurs paramètres pendant chaque trame, éventuellement mémorisés dans une mémoire non représentée.

Par exemple, en référence à la figure 31, l'unité de calcul d'histogramme 1 calcule des histogrammes et les statistiques correspondantes pour deux ou plus paramètres (par exemple DATA(A) et DATA(C)) pendant chaque trame.

15 Un multiplexeur 500 prévu dans ce mode de réalisation est susceptible de multiplexer les différents paramètres. De cette façon, un nombre limité d'unités de calcul d'histogramme est nécessaire pour traiter un plus grand nombre de paramètres, ce qui permet de diminuer la quantité de silicium nécessaire pour fabriquer le nombre utile d'unités de calcul d'histogramme.

20 Le processeur de perception visuelle générique (GVPP) 520 ainsi constitué peut être intégré sur un seul substrat semi-conducteur.

Le nombre d'unités de calcul d'histogramme polyvalentes 1a dépend de l'application et des technologies de fabrications de composants semi-conducteurs disponibles.

25 La technologie 0,5 μm actuellement accessible permet l'intégration de 32 unités de façon économique. Avec les techniques avancées de semi-conducteurs, il devient impossible de fabriquer de plus en plus d'unités de calcul d'histogramme (par exemple les blocs 1a de la figure 32) sur le même composant et de réaliser des calculs plus nombreux sur plus d'échantillons (c'est-à-dire des nombres de plus en plus importants d'échantillonnage par paramètre).

30 Une telle augmentation des capacités de calcul peut être réalisée sans augmentation de la complexité de l'API, qui est présentée plus loin et représentée en détail sur l'annexe A. Par exemple, le même ensemble d'instructions peut commander un ensemble de 20 unités comme un

ensemble de 200 ou même de 2000 unités sans que sa complexité ne soit accrue.

Dans un autre mode de réalisation représenté sur la figure 39, une unité de calcul 605 conforme à la présente invention, c'est-à-dire similaire à l'unité de calcul 520 de la figure 32, est utilisée pour traiter les paramètres associés à un domaine de perception autre que le domaine visuel. Sur la figure 39, la technique de la présente invention est appliquée à l'analyse orale ou de son, par exemple pour la reconnaissance vocale ou l'utilisation de la voix pour entrer un texte dans un ordinateur. Sur la figure 39, un dispositif générant un signal sonore fournit un signal sonore au calculateur 605 qui produit un signal de sortie.

Dans un mode de réalisation, le dispositif générant le signal comporte un microphone 600 mais peut aussi comprendre n'importe quel dispositif susceptible de fournir des signaux analogues ou digitaux, par exemple un lecteur CD ou DVD... Le dispositif générateur de signal fournit de préférence des signaux digitaux et peut fonctionner dans un mode esclave ou dans un mode maître de la même manière que l'ensemble générateur de signal 2 de la figure 1. Le calculateur 605 reçoit les signaux et traite différents paramètres du signal sonore. Ces paramètres comportent la fréquence, l'amplitude et la phase. Les paramètres de phase et d'amplitude sont respectivement analogues aux signaux spatiaux et temporels exploités pour le traitement de scènes visuelles. Le calculateur 605 fournit des signaux au dispositif 610 de façon à permettre la représentation des résultats. Par exemple, dans un mode de réalisation, le dispositif 610 comporte une imprimante permettant l'impression de textes associés aux signaux fournis par le générateur de signal 600. De la même manière, le dispositif 610 peut comporter un moniteur ou n'importe quel autre dispositif générateur de texte.

La figure 33 est la représentation d'un processeur de perception visuelle générique 520 ou 530 recevant des informations d'un imageur CMOS 521 comportant une rétine 522 et un séquenceur 523.

La figure 34 représente un système complet susceptible de constituer une application complète et fonctionnant avec plusieurs imageurs CMOS. L'association de deux imageurs CMOS 531, 532 représentés sur la figure 35 permettant d'acquérir des informations sur la profondeur dans la scène observée.

Dans certaines utilisations, il est souhaitable de pouvoir observer certains plans, en profondeur, d'une scène et c'est la raison pour laquelle la rétine peut être équipée d'un dispositif à focale variable tel que représenté sur la figure 36.

- 5 La figure 37 schématise un système constitué d'un ensemble d'unités de calcul d'histogramme polyvalente susceptible de traiter des informations provenant de trois directions, respectivement V1, V2 et V3 pouvant représenter un espace tridimensionnel. On peut ainsi gérer des données de perception volumique et les utiliser dans le domaine de la robotique.

10 **XVII. Interface de gestion de l'application (A.P.I.)**

L'interface de gestion de l'application (A.P.I. - Application Programm Interface) représentée sur la figure 38 permet de fournir à système complet ou processeur de perception visuelle générique composé d'un certain nombre de d'unités de calcul d'histogramme polyvalentes, l'ensemble des paramètres
15 extérieurs dont il a besoin. On assure ainsi sa configuration dynamique. L'annexe A qui est jointe, fait partie intégrante de la description de la présente demande, elle fournit un diagramme fonctionnel de l'unité spatio-temporelle API, l'interface graphique utilisatrice (GUI) API, la souris API et le I/O API, ainsi que les différentes commandes API associées.

20 Chacun des mnémoniques de commande est associé à un indice *i* correspondant au numéro de l'unité de calcul d'histogramme polyvalente à laquelle il est destiné. Il peut être accompagné de paramètres de configuration.

Elle permet d'affecter les paramètres DATA(A)... DATA(E) à des
25 paramètres réels de la scène observée.

SELECT permet d'attribuer un paramètre DATA(A) à une unité déterminée.

LEARN_{*i*} permet d'effectuer l'apprentissage pour une d'unité de calcul d'histogramme polyvalente *i*.

30 START assure l'initialisation d'une unité de calcul d'histogramme polyvalente. Cette commande configure la mémoire 118 de classifieur 101.

STOP assure l'arrêt de l'unité de calcul d'histogramme polyvalente. Elle est utilisée dès qu'une unité de calcul d'histogramme est inactive. On réduit ainsi la consommation d'énergie de l'ensemble.

AFCURV est la commande d'affichage de courbe commandant le commutateur 16 représenté sur la figure 4. Sa commande inverse est CLCURV.

5 AFMAP est la commande d'affichage de la rétroannotation commandant le commutateur 17. Sa commande inverse est CLRMAP.

MAP est la commande d'écriture des registres 411 et 412 de l'unité de rétroannotation 102.

GETLRN est la commande assurant la récupération du contenu des registres de rétroannotation 411 et 412 après l'apprentissage.

36
ANNEXE A

Spécifications API
(Application Programming Interface)

interface de programmation applicative (API)
pour le Processeur de Perception Visuelle Générique : (GVPP)

L'interface comporte 4 subdivisions pour GVPP :

- Une API Bloc spatio-temporel
- Une API graphique
- Une API de gestion de la souris
- Une API de gestion de la communication avec les périphériques

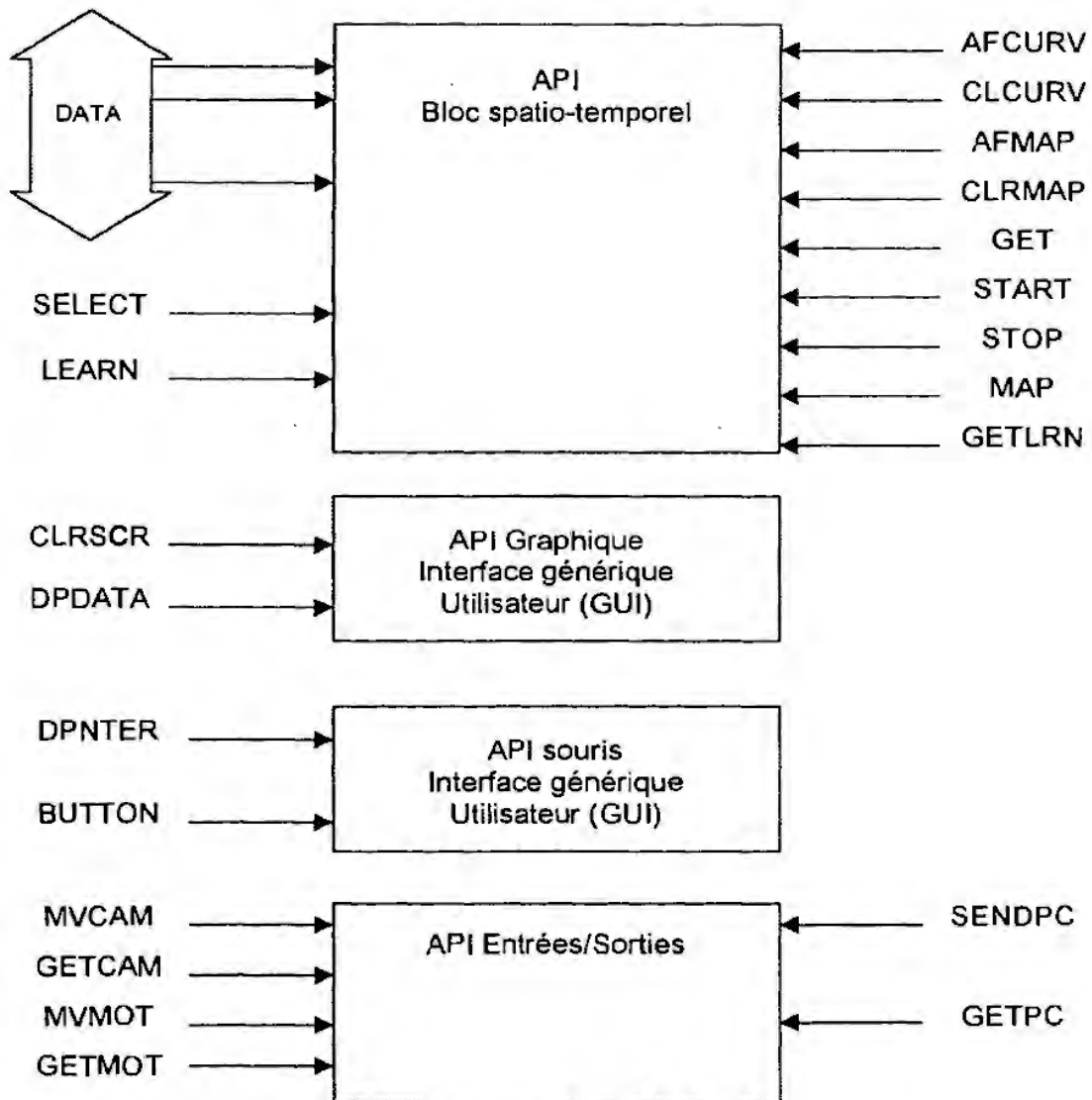

Description des commandes de programmation applicatives

API Bloc Spatio-temporel

Elle regroupe l'ensemble des fonctions génériques utilisées pour initialiser, paramétrer ou apprendre et démarrer le bloc ainsi que les fonctions pour récupérer les résultats de calcul. Le nom de la commande est suivi des paramètres nécessaires écrit dans des registres définis.

Fonctions :

START :

Rôle : Démarrage du calcul d'un bloc.

Paramètres : Numéro du bloc concerné, valeur MIN, valeur MAX pour initialisation

Prototype :

```
Bloc3 equ 03
MIN equ 10
MAX equ 100
```

START Bloc3 MIN MAX

```
Entrée - R0 : numéro du bloc
          R1 : valeur MIN
          R2 : valeur MAX
```

Sortie -

STOP :

Rôle : Arrêt du calcul d'un bloc.

Paramètres : Numéro du bloc concerné.

Prototype :

```
Bloc3 equ 03 : equivalence Bloc3 est egal à la valeur 3
```

STOP Bloc3

```
Entrée - R0 : numéro du bloc
```

Sortie -

SELECT :

Rôle : Sélection du signal d'entrée d'un bloc. Par exemple la luminance, la teinte, la saturation, l'orientation de lignes dans le plan...etc.

Paramètres : Numéro du bloc concerné, signal a sélectionner.

Prototype :

Bloc3 equ 03
LUM equ 00

SELECT Bloc3 LUM

Entrée - R0 : Numéro du bloc
R1 : Parametre d'entrée
Sortie -

GET :

Rôle : Récupération des résultats de calcul.

Paramètres : Numéro du bloc concerné, paramètre(s) a recuperer.

Prototype :

Bloc3 equ 03
MIN equ 00
MAX equ 01
RMAX equ 02
POSRMX equ 03
POSMOY equ 04
NBPTS equ 05
.....

GET Bloc3 NBPTS

Entrée - R0 : Numéro du bloc
R1 : Parametre d'entrée
Sortie - R0 : valeur résultante de ce parametre

LEARN :

Rôle : Passage d'un bloc en mode apprentissage.

Paramètres : Numéro du bloc concerné.

Prototype :

Bloc3 equ 03

LEARN Bloc3

Entrée - R0 : Numéro du bloc
Sortie -

MAP :

Rôle : Programmation du bloc en fonction d'un apprentissage précédent pour changer de contexte. Recherche d'un autre événement ou objet :
écriture de la matrice de rétro annotation du bloc.

Paramètres : Numéro du bloc concerné, Combinaison logique des autres blocs associés ; somme de termes produits (ET et OU).

Prototype :

Bloc3 equ 03

MAP Bloc3 0F3 1AB 007

Entrée- R0 : Numéro du bloc
 R1 : Premier terme produit
 R2 : Second terme produit
 R3 : suite

Sortie-

GETLRN :

Rôle : Lecture des résultats de l'apprentissage .

Paramètres : Numéro du bloc concerné.

Prototype :

GETLRN

Entrée - R0 : Numéro du bloc
 Sortie - R0 : MIN classification
 R1 : MAX Classification
 R2 : Première majeure association (terme produit)
 R3 : Seconde association
 R4 : suite

AFCURV :

Rôle : Affichage de la courbe d'un bloc.

Paramètres : Numéro du bloc concerné.

Prototype :

Bloc3 equ 03

AFCURV Bloc3

Entrée - R0 : Numéro du bloc
 Sortie -

CLCURV :

Rôle : Effacement de la courbe d'un bloc.

Paramètres : Numéro du bloc concerné.

40

Prototype :

Bloc3 equ 03

CLCURV Bloc3

Entrée - R0 : Numéro du bloc

Sortie -

AFMAP :

Rôle : Affichage de la table de rétro-annotation d'un bloc.

Paramètres : Numéro du bloc concerné.

Prototype :

Bloc3 equ 03

AFMAP Bloc3

Entrée - R0 : Numéro du bloc

Sortie -

CLRMAP :

Rôle : Effacement de l'écran de la table de rétro-annotation d'un bloc.

Paramètres : Numéro du bloc concerné.

Prototype :

Bloc3 equ 03

CLRMAP Bloc3

Entrée - R0 : Numéro du bloc

Sortie -

API Graphique

CLRSCR :

Rôle : Effacement de l'écran.

Paramètres : Aucun.

Prototype :

CLRSCR

Entrée -

Sortie -

DPDATA :

Rôle : Affichage des données à l'écran.
 Paramètres : Donnée à afficher et position à l'écran.

Prototype :

DPDATA
 Entrée- R0 : Code ASCII
 R1 : position ligne
 R2 : position colonne
 Sortie-

API de gestion de la souris**DPNTER :**

Rôle : Déplacer et afficher curseur.
 Paramètres : Coordonnées.

Prototype :

DPNTER
 Entrée- R0 : position ligne
 R1 : position colonne
 Sortie-

BUTTON :

Rôle : Générer un click curseur.
 Paramètres : Boutton.

Prototype :

BUTTON
 Entrée-
 Sortie-R0 : nouvelle position des boutons

API de gestion de la communication avec les périphériques**MVCAM :**

Rôle : Déplacer la caméra.
 Paramètres : Position et focus.

Prototype :

MVCAM

42
Entrée - R0 : X position
R1 : Y position
R2 : Focus
Sortie -

GETCAM :

Rôle : Récuperer la position de la caméra.
Paramètres : Aucun.

Prototype :

GETCAM
Entrée-
Sortie- R0 : X position
R1 : Y position
R2 : Focus

MVMOT :

Rôle : Action moteur.
Parametre : Sens+nombre de pas.

Prototype :

MVCAM
Entrée - R0 : Sens+nombre de pas
Sortie -

GETMOT :

Rôle : Recupere la position actuelle du moteur.
Parametre : Non

Prototype :

GETMOT
Entrée -
Sortie - R0 : position

SENDPC :

Rôle : Envoyer une information au PC.
Paramètres : pointer sur l'information et nombre d'informations.

Prototype :

SENDPC
Entrée- R0 : pointeur information
R1 : nombre d'informations
Sortie-

GETPC :

Rôle : Récupérer une information du PC.
Paramètres : Aucun.

Prototype :

GETPC
Entrée-
Sortie-R0 : information

REVENDICATIONS

1. Dispositif de perception automatique d'un événement intervenant dans un espace par rapport à au moins un paramètre, caractérisé en ce qu'il comporte une unité de contrôle (513), un bus de données (510), un bus de
- 5 rétroannotation et au moins une unité de calcul d'histogramme pour le traitement dudit paramètre.
2. Dispositif de perception automatique selon la revendication 1, caractérisé en ce qu'il comporte, pour traiter plusieurs paramètres, plusieurs unités de calcul d'histogramme organisées en matrice.
- 10 3. Dispositif de perception automatique selon l'une des revendications 1 et 2, caractérisé en ce que les unités de calcul d'histogramme traitent des données a_{ijt} associées à des pixels formant ensemble un espace (i, j) multidimensionnel évoluant dans le temps et représenté à une succession de moments (T), lesdites données parvenant à ladite unité de calcul sous la
- 15 forme d'un signal DATA(A) numérique sous forme d'une suite a_{ijt} de nombre binaire de n bits associé à des signaux de synchronisation permettant de définir le moment donné (T) de l'espace et la position (i, j) du pixel dans cet espace, auquel le signal a_{ijt} reçu à un instant donné (t) est associé, comprenant :
- 20 - une mémoire d'analyse (100) comportant une mémoire avec des adresses, chacune associée à des valeurs possibles des nombres de n bits du signal DATA(A) et dont l'écriture est contrôlée par un signal " WRITE ",
- un classifieur (101) comportant une mémoire destinée à recevoir un critère C de sélection du paramètre DATA(A), recevant le signal DATA(A) en
- 25 entrée et fournissant, en sortie, un signal binaire de classification dont la valeur dépend du résultat de la comparaison du signal DATA(A) avec le critère (C) de sélection,
- une unité de rétroannotation (102) recevant le signal de sortie du classifieur et, de l'extérieur de l'unité de calcul de l'histogramme, des signaux
- 30 binaires de classification individuels concernant des paramètres autres que DATA(A), ladite unité de rétroannotation fournissant en sortie un signal de validation global positif lorsque l'ensemble des signaux de rétroannotation individuels sont positifs,
- une unité de test (103),
- 35 - une unité de sortie d'analyse (104),

- un multiplexeur d'adresses (105),
- une unité de validation d'incrémentation (107),

le compteur de chaque adresse de la mémoire correspondant à la valeur (d) de a_{ijt} à un instant donné, étant incrémentée d'une unité lorsque
 5 l'unité de rétroannotation fournit en sortie un signal de validation global positif,

l'unité (103) de calcul et de mémorisation de données statistiques exploitant à la fin de la réception des données a_{ijt} correspondant à l'espace à un moment (T) le contenu de la mémoire (100) pour mettre à jour l'unité de
 10 sortie d'analyse 104,

la mémoire (100) étant effacée avant le début de chaque trame pour un espace à un moment (T) par un signal d'initialisation " INIT ",

et qu'en outre :

- la mémoire du classifieur (101) est une mémoire adressable
 15 permettant la mise à jour en temps réel du critère de sélection (C) et ayant une entrée de données DATA IN, une commande d'adresse ADRESS et une commande d'écriture WR, recevant sur son entrée la sortie de la mémoire d'analyse et un signal END sur sa commande d'écriture,

- les unités de traitement d'histogramme comportent, de plus, un
 20 multiplexeur d'entrées de données (108) ayant deux entrées et une sortie, recevant sur l'une de ses entrées un signal de comptage COUNTER et, sur l'autre de ses entrées, la suite de données a_{ijt} et fournissant en sortie la suite de données a_{ijt} à la commande d'adresse de la mémoire du classifieur et un opérateur OU commandant le multiplexeur d'adresses (105) et recevant sur
 25 ses entrées un signal d'initialisation INIT et le signal de fin END.

4. Dispositif de perception automatique selon la revendication 3, caractérisé en ce que l'espace (i, j) est à deux dimensions et que le signal DATA(A) est associé aux pixels d'une succession d'images.

5. Dispositif de perception automatique selon l'une quelconque des
 30 revendications 3 et 4, caractérisé en ce que les unités de traitement d'histogramme comportent des moyens d'anticipation de la valeur du critère de sélection (C).

6. Dispositif de perception automatique selon la revendication 5, caractérisé en ce que les moyens d'anticipation de la valeur du critère de

sélection (C) comportent des mémoires destinées à contenir les valeurs de paramètres statistiques relatives à deux trames successives (T_0 et T).

5 7. Dispositif de perception automatique selon la revendication 6, caractérisé en ce que les paramètres statistiques sont les valeurs moyennes des données a_{ijt} validées.

8. Dispositif de perception automatique selon l'une quelconque des revendications 3 à 7, caractérisé en ce que le registre de sortie d'analyse (104) des unités de calcul d'histogramme constitue et garde en mémoire l'une au moins des valeurs suivantes : la valeur minimum " MIN ", la valeur
10 maximum " MAX ", le nombre maximum de pixels pour lesquels le signal V_{ijt} a une valeur particulière " RMAX ", la valeur particulière correspondante POSRMAX, le nombre total de pixels validés " NBPTS ".

9. Dispositif de perception automatique selon l'une quelconque des revendications 3 à 8, caractérisé en ce que le paramètre statistique de
15 comparaison utilisé par le classifieur est $RMAX/2$.

10. Dispositif de perception automatique selon l'une quelconque des revendications 3 à 8, caractérisé en ce qu'il comporte un multiplexeur commandé, pouvant recevoir en entrée plusieurs paramètres statistiques et que la nature de la comparaison faite par le classifieur dépend de la
20 commande de ce multiplexeur.

11. Dispositif de perception automatique selon l'une quelconque des revendications 3 à 10 caractérisé en ce que certaines unités de calcul d'histogramme, au moins, comportent un multiplexeur d'apprentissage destiné à recevoir un signal de commande extérieur et produisant un
25 fonctionnement selon un mode d'apprentissage dans lequel les registres du classifieur et de l'unité de rétroannotation sont effacés au début de l'exploitation d'une trame et que le registre de sortie d'analyse fournit des valeurs caractéristiques de la séquence pour chacun de ces registres.

12. Dispositif de perception automatique selon l'une quelconque des revendications 3 à 11, caractérisé en ce que dans certaines unités de calcul
30 d'histogramme, au moins, la mémoire du classifieur (101) est constituée d'un ensemble de registres (D) indépendants comportant chacun une entrée, une sortie et une commande d'écriture, le nombre de ces registres (D) étant égal au nombre n de bits des nombres de la suite V_{ijt} , et qu'elle comporte un
35 décodeur permettant de sortir un signal de commande d'écriture

correspondant à la valeur d'entrée (adresse) associée et un multiplexeur commandé par cette valeur d'entrée, permettant de lire le registre choisi.

5 13. Dispositif de perception automatique selon l'une quelconque des revendications 3 à 12, caractérisé en ce que certaines unités de calcul d'histogramme au moins, comportent des multiplexeurs, un d'entre eux étant associé à l'entrée de chaque registre et des modules combinatoires reliant entre eux les registres, lesdits multiplexeurs permettant le choix entre l'écriture séquentielle et une écriture commune à tous les registres liés entre eux par les modules combinatoires.

10 14. Dispositif de perception automatique selon l'une quelconque des revendications 3 à 13, caractérisé en ce que dans certaines unités de calcul d'histogramme au moins, les modules combinatoires comportent un opérateur morphologique de dilatation comportant une unité logique " OU " à trois entrées dont la première reçoit le signal de sortie du registre de rang " Q ", la deuxième est reliée à la sortie d'une unité logique " ET " à deux entrées recevant respectivement le signal de sortie du registre de rang " Q+1 " et un signal de dilatation positive, la troisième est reliée à la sortie d'une unité logique " ET " à deux entrées recevant respectivement le signal de sortie du registre de rang " Q-1 " et un signal de dilatation négative.

20 15. Dispositif de perception automatique selon l'une quelconque des revendications 3 à 13, caractérisé en ce que dans certaines unités de calcul d'histogramme au moins, les modules combinatoires comportent un opérateur morphologique d'érosion comportant une unité logique " ET " à trois entrées dont la première reçoit le signal de sortie du registre de rang " Q ", la deuxième est reliée à la sortie d'une unité logique " ET " dont une inversée à quatre entrées recevant respectivement le signal de sortie du registre de rang " Q ", le signal de sortie du registre de rang " Q-1 ", le signal de sortie du registre de rang " Q+1 " et un signal d'érosion positive, la troisième est reliée à la sortie d'une unité logique " ET " à quatre entrées dont une inversée recevant respectivement le signal de sortie du registre de rang " Q ", le signal de sortie du registre de rang " Q-1 ", le signal de sortie du registre de rang " Q+1 " et un signal d'érosion négative.

35 16. Dispositif de perception automatique selon l'une quelconque des revendications 14 et 15, caractérisé en ce que dans certaines unités de calcul d'histogramme au moins, chaque module combinatoire comporte un

multiplexeur associant un opérateur morphologique d'érosion et un opérateur morphologique d'érosion.

5 17. Procédé de perception automatique d'un événement intervenant dans un espace par rapport à au moins un paramètre consistant à le digitaliser et à le fournir en entrée à une unité de calcul d'histogramme pour former un histogramme représentatif du paramètre et en déduire le résultat désiré.

10 18. Procédé selon la revendication 17, caractérisé en ce que l'événement est représenté par plusieurs paramètres et que le résultat provient de plusieurs unités de calcul d'histogramme.

15 19. Procédé d'analyse conforme à l'une des revendications 17 et 18 d'un paramètre représentatif d'un événement dans un dispositif électronique comprenant un calcul d'histogramme sur des données a_{ijt} associées à des pixels formant ensemble un espace (i, j) multidimensionnel évoluant dans le temps et représenté à une succession de moments (T) , lesdites données parvenant à ladite unité de calcul sous la forme d'un signal $DATA(A)$ numérique sous forme d'une suite a_{ijt} de nombre binaire de n bits associé à des signaux de synchronisation permettant de définir le moment donné (T) de l'espace et la position (i, j) du pixel dans cet espace, auquel le signal a_{ijt} reçu
20 à un instant donné (t) est associé dans lequel

- on associe à chaque donnée a_{ijt} un signal binaire de classification dont la valeur dépend du résultat de la comparaison du signal $DATA(A)$ avec le critère (C) de sélection,

25 - on constitue une répartition statistique des données a_{ijt} pour un moment (T) donné pour lesquelles un signal de validation global est positif, ledit signal de validation global étant constitué d'un ensemble de signaux de rétroannotation individuels chacun correspondant à un paramètre $DATA(A)$, $DATA(B)$,... $DATA(E)$, résultant de la comparaison entre un critère de rétroannotation R et de son signal de classification et étant positif.

30 20. Procédé d'analyse d'un paramètre selon la revendication 19, caractérisé en ce que l'espace (i, j) est à deux dimensions et que le signal $DATA(A)$ est associé aux pixels d'une succession d'images.

35 21. Procédé d'analyse d'un paramètre selon l'une des revendications 19 et 20, caractérisé en ce que le critère de classification (C) est mis à jour, en temps réel, en fonction de la répartition statistique.

22. Procédé d'analyse d'un paramètre selon la revendication 21, caractérisé en ce que la mise à jour du critère de classification (C) dépend de l'évolution de la valeur moyenne du paramètre a_{ijt} validé entre deux trames successives (T_0 et T_1).

5 23. Procédé d'analyse d'un paramètre selon l'une quelconque des revendications 20 à 22, caractérisé en ce que la mise à jour du critère de classification (C) est anticipée.

10 24. Procédé d'analyse d'un paramètre selon la revendication 23, caractérisé en ce que l'anticipation de la mise à jour du critère de classification (C) résulte d'applications successives d'un opérateur de dilatation et d'un opérateur d'érosion, chacun d'eux, un nombre de fois et dans un sens dépendant de l'évolution de la valeur moyenne du paramètre a_{ijt} validé entre deux trames successives (T_0 et T_1).

15 25. Procédé d'analyse d'un paramètre selon l'une quelconque des revendications 19 à 24, caractérisé en ce que le critère de rétroannotation (R) est complexe.

20 26. Procédé d'analyse d'un paramètre selon l'une quelconque des revendications 19 à 25, caractérisé en ce que le critère de rétroannotation (R) est automatiquement proposé à la suite d'une étape d'apprentissage.



Le Mandataire
Cabinet HARLE & PHELIP

L'invention concerne un procédé et un dispositif de perception automatique. Le dispositif comporte une unité de calcul d'histogramme, de préférence auto-adaptative éventuellement avec anticipation et apprentissage. Ils sont plus particulièrement destinés à la perception et au
5 traitement d'images.

On connaît des procédés et des dispositifs de traitement d'images permettant, en temps réel, de reconnaître, de localiser et/ou d'extraire des objets correspondants à certains critères de leur contexte.

Les critères de sélections peuvent être extrêmement variés. Il peut
10 s'agir d'une vitesse, d'une forme, d'une couleur... ou d'une combinaison de ces critères.

Ces procédés et dispositifs peuvent être utilisés pour faciliter l'appréhension d'une scène ou d'un phénomène par un observateur ou pour commander un automatisme à partir des informations ainsi extraites.

De tels procédés et dispositifs sont par exemple décrits dans les
15 publications suivantes FR-2.611.063 et WO-98/05002.

Certains de ces procédés et dispositifs mettent en œuvre une unité de traitement spatial et temporel qui, recevant un signal $S(PI)$ de type vidéo, produit un certains nombre de paramètres pour chaque pixel. Il s'agit par
20 exemple de la vitesse V , de la direction DL , d'une constante de temps CO , et d'un paramètre binaire de validation VL en plus du signal vidéo retardé VR et des différents signaux de synchronisation de trame, de ligne et de pixel regroupés sous la dénomination F .

Dans de tels dispositifs, on a déjà souligné l'intérêt de constituer des
25 histogrammes de ces paramètres permettant la constitution la manipulation et l'exploitation d'informations statistiques.

Le but de ces procédés et de ces dispositifs de traitement d'images est de fournir en sortie un signal $S'(t)$ qui porte pour chaque pixel une information significative du résultat de l'application de critères de reconnaissance ou de
30 sélection. Ces critères sont prédéfinis ou élaborés par les procédés et dispositifs de traitements d'images eux mêmes.

On connaît en particulier un tel procédé et un tel dispositif décrit dans la demande de brevet WO-98/05002, déjà citée

ART ANTERIEUR

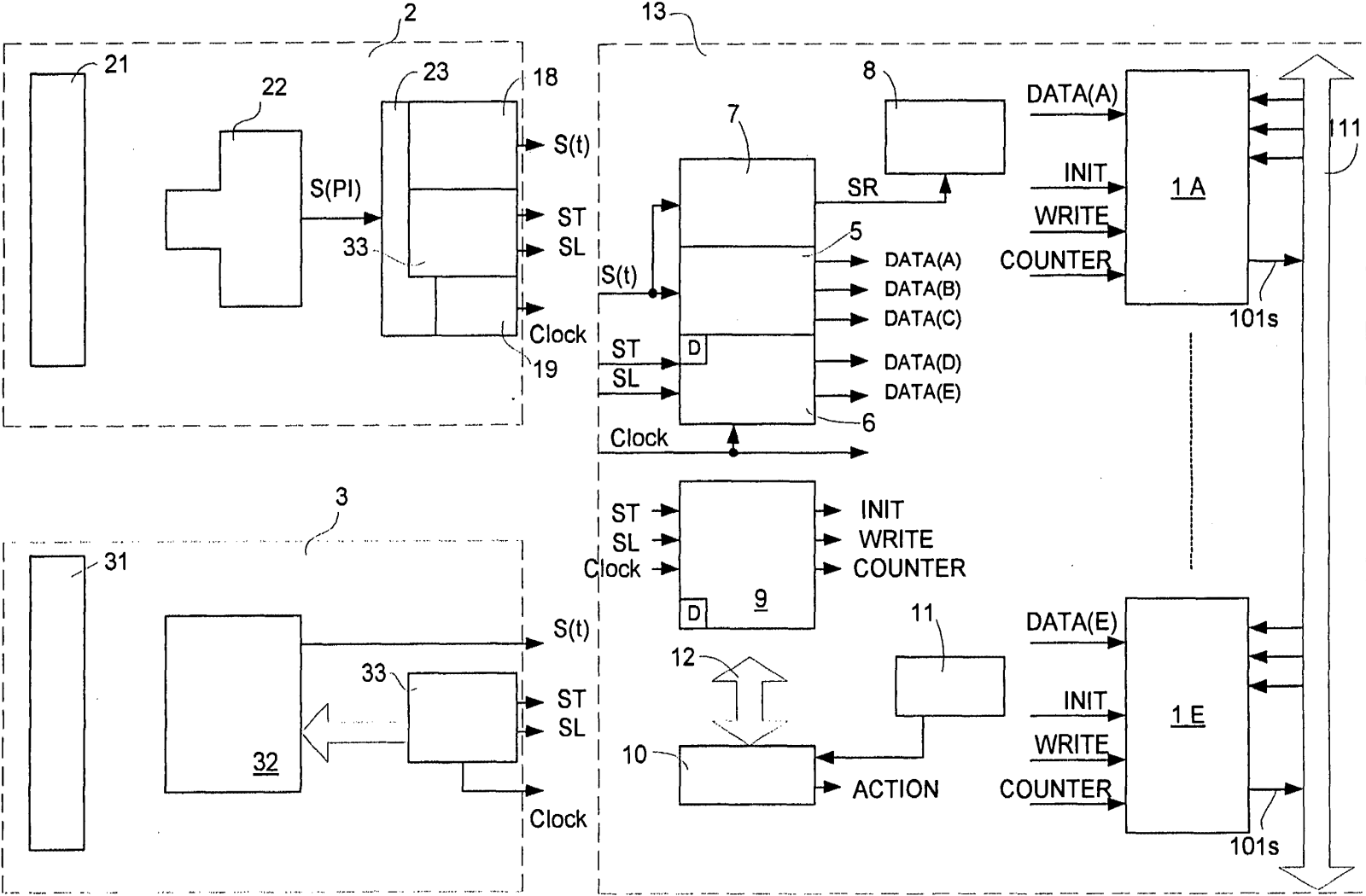

FIG. 1

1/26

ORIGINAL

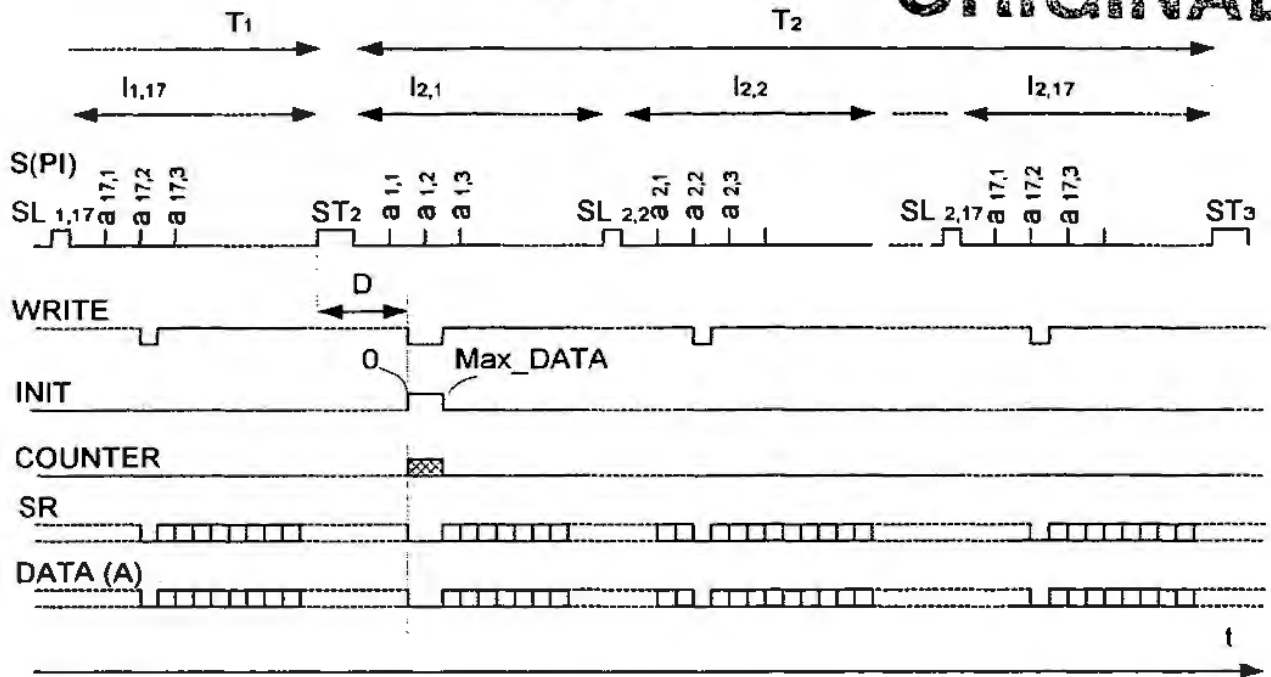

FIG. 2

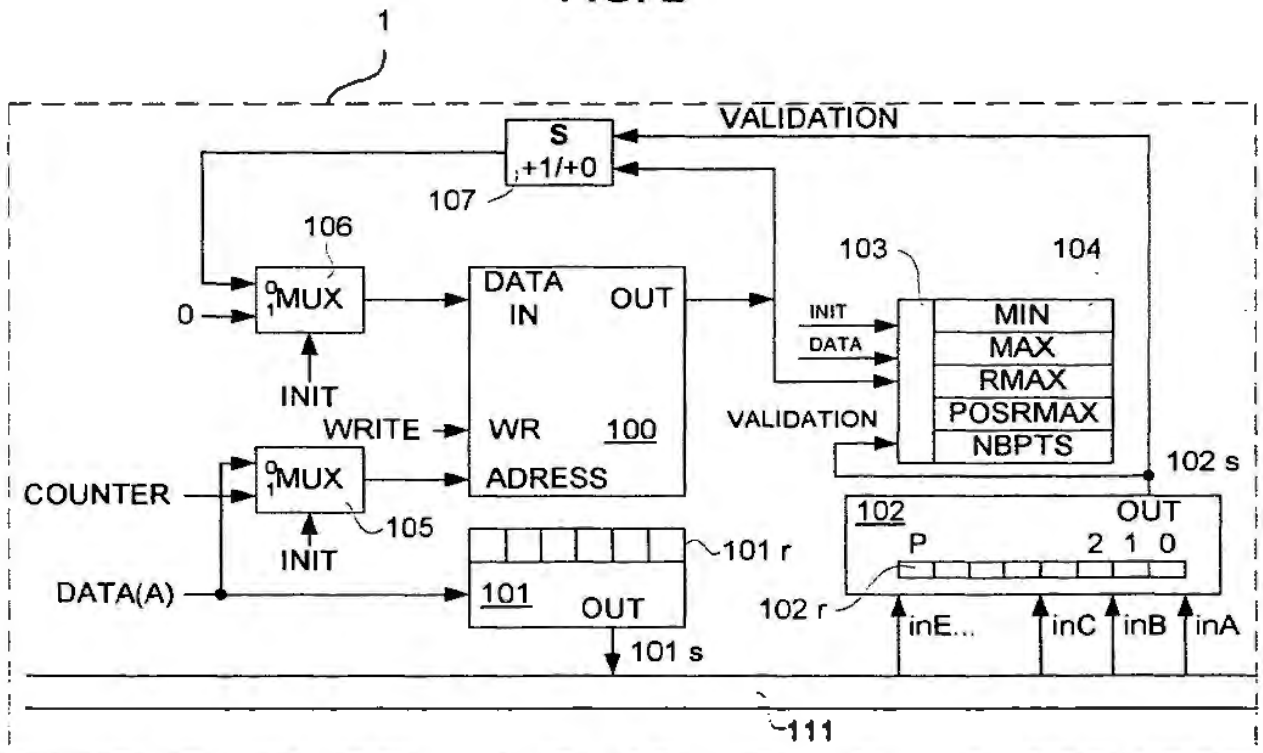

FIG. 3

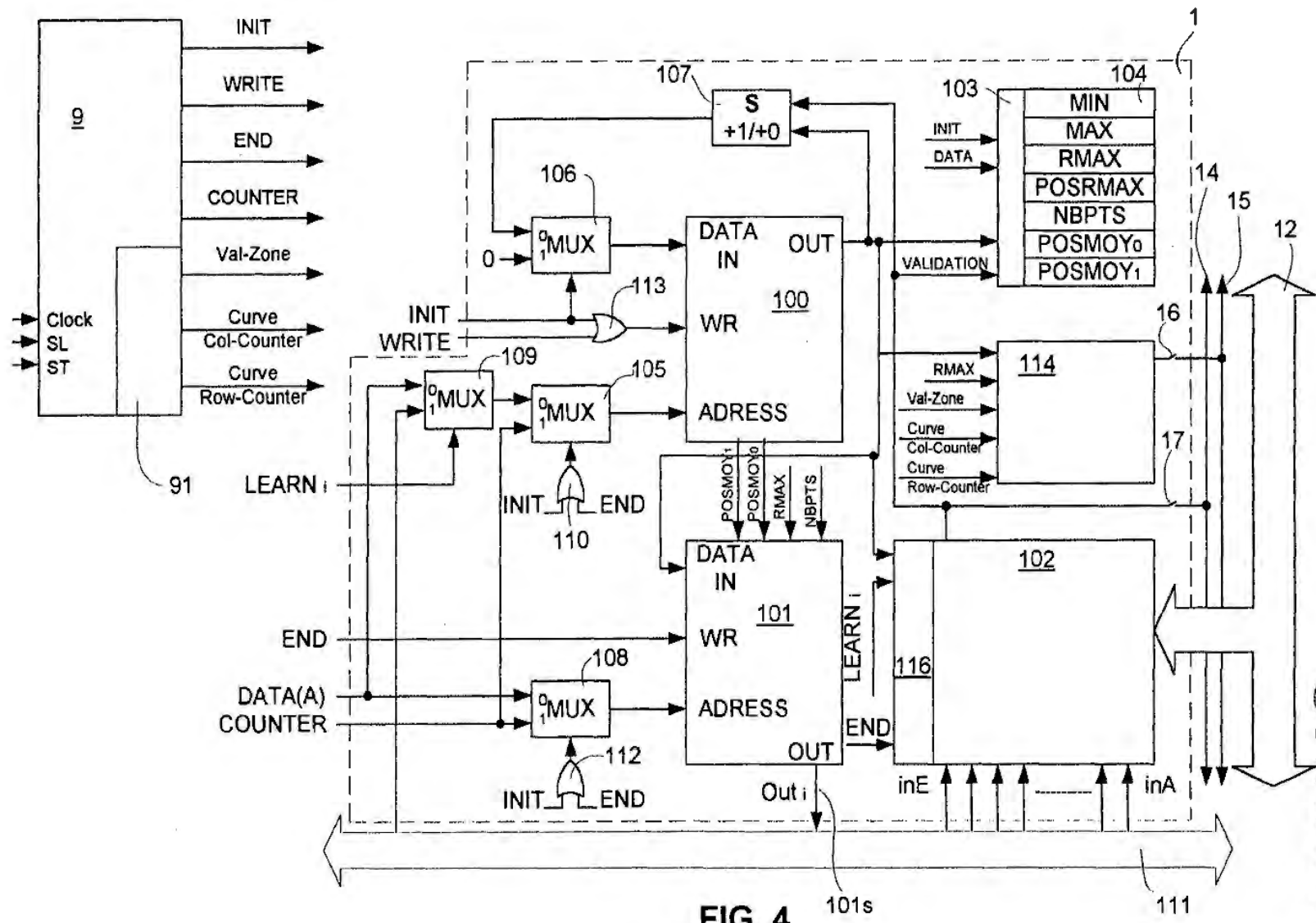

FIG. 4

3/26

ORIGINAL

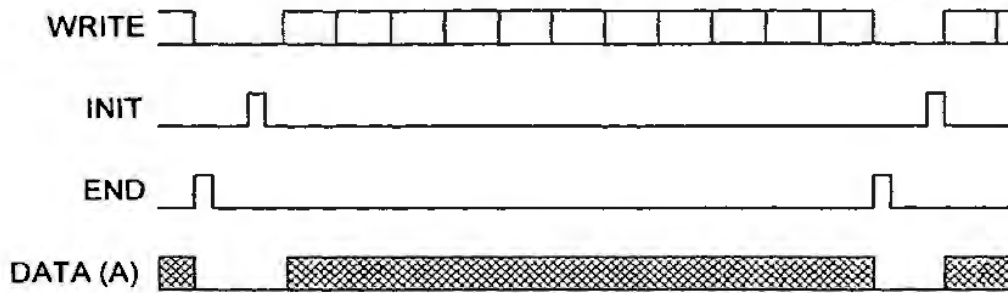

FIG. 5

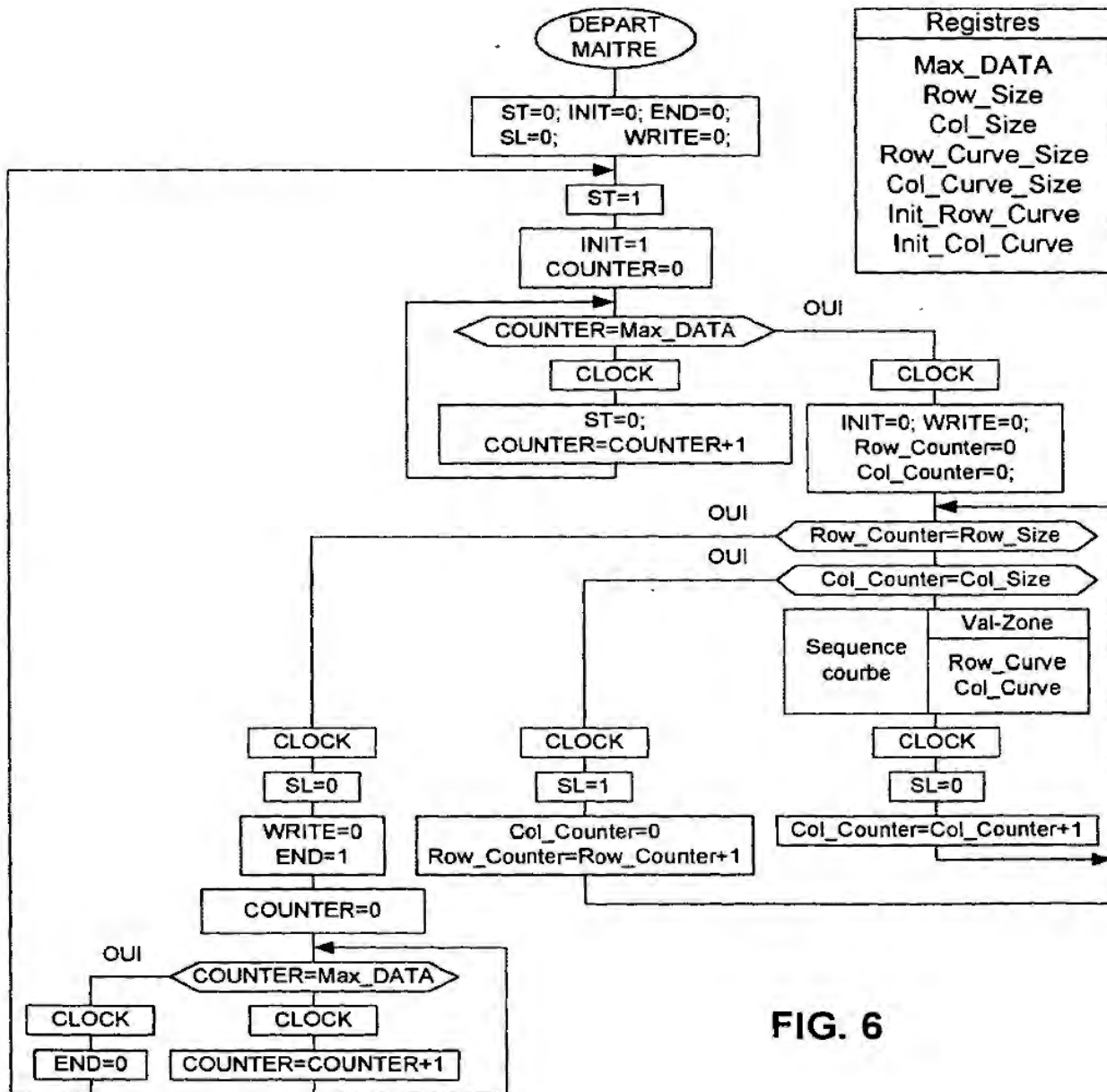

FIG. 6

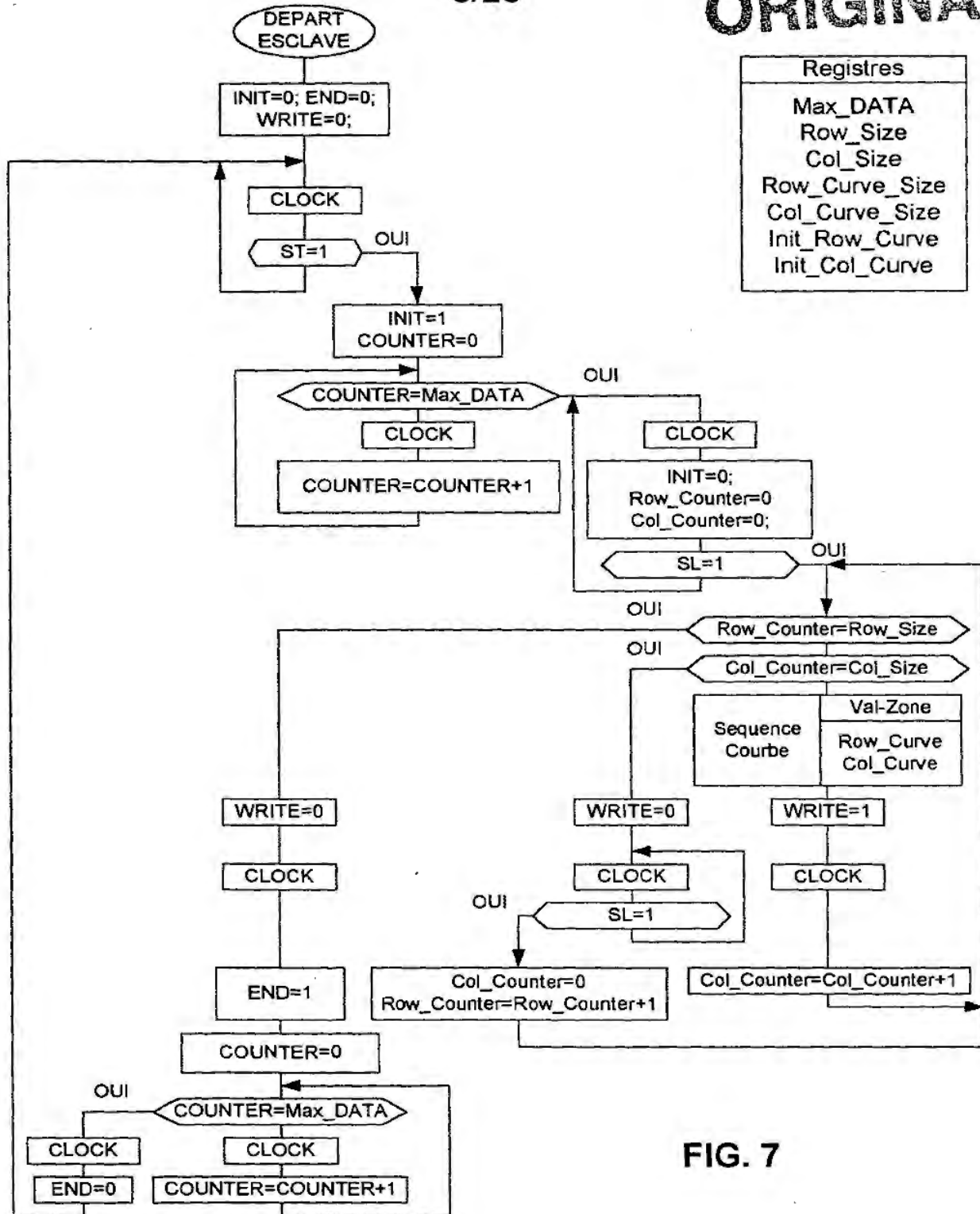

FIG. 7

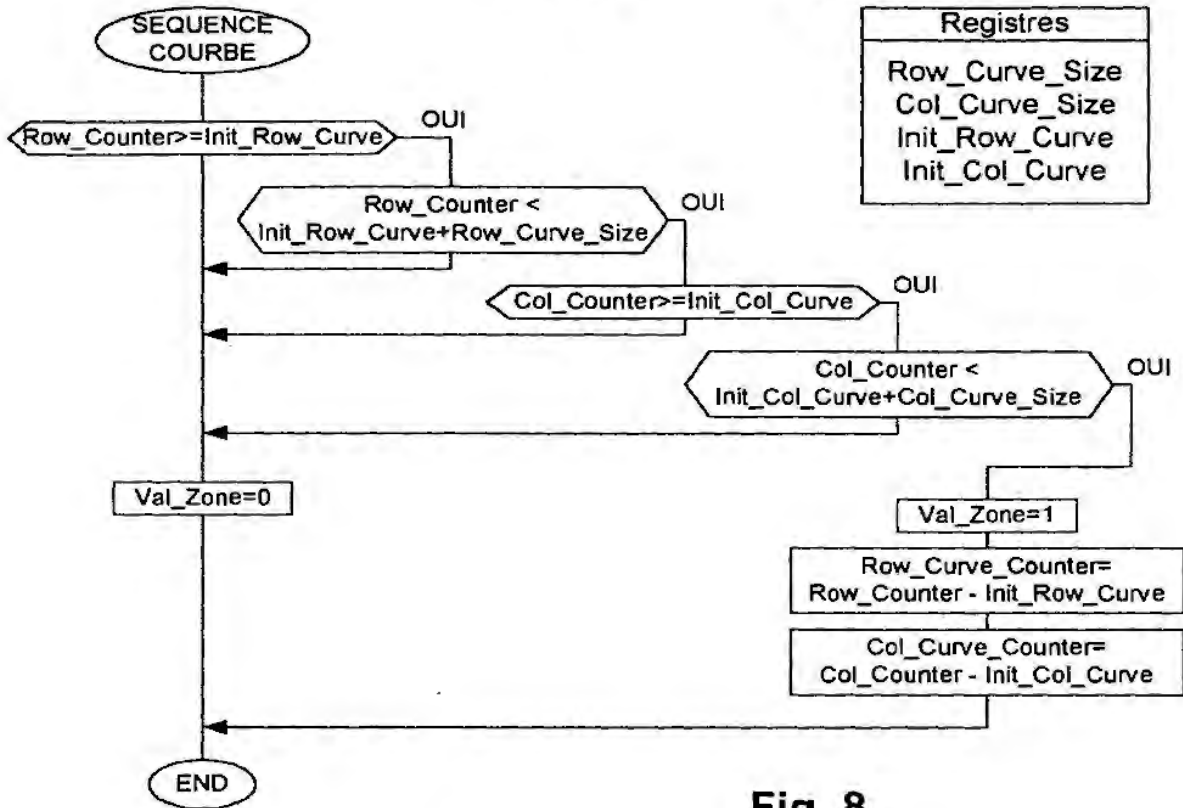

Fig. 8

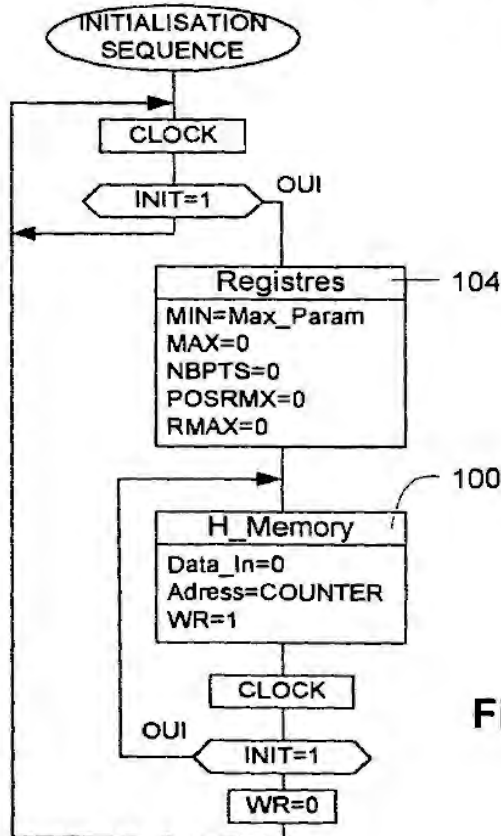

Fig. 9

ORIGINAL

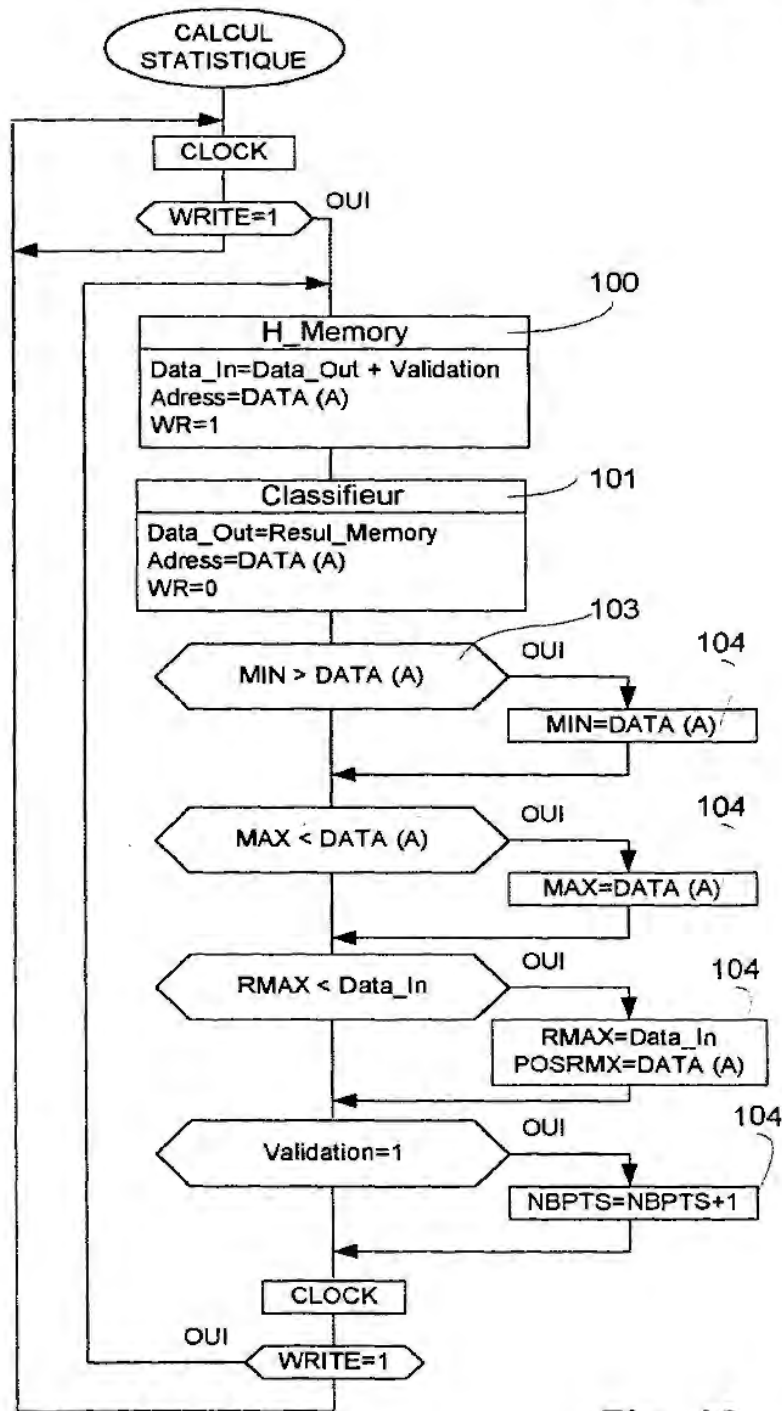

Fig. 10

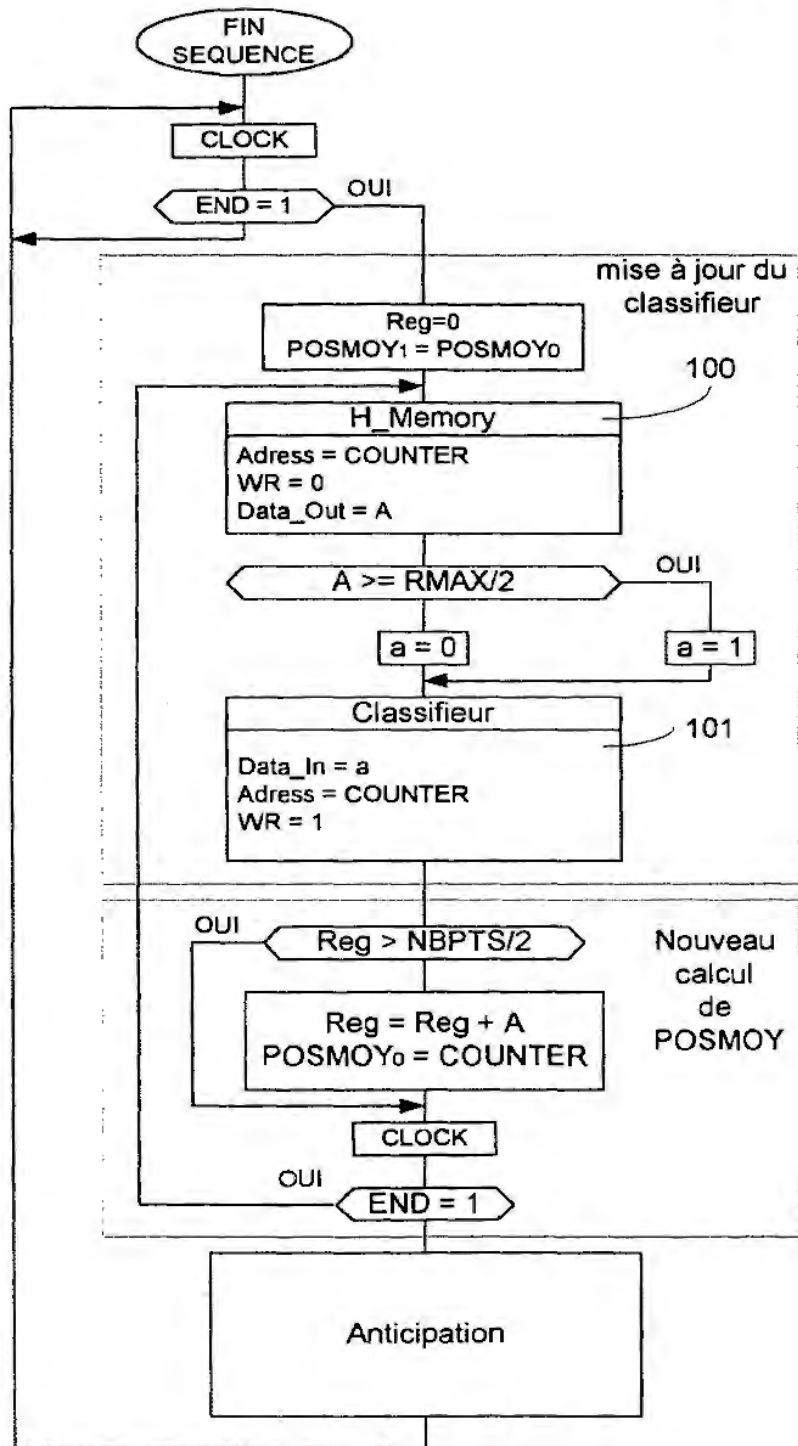

Fig. 11

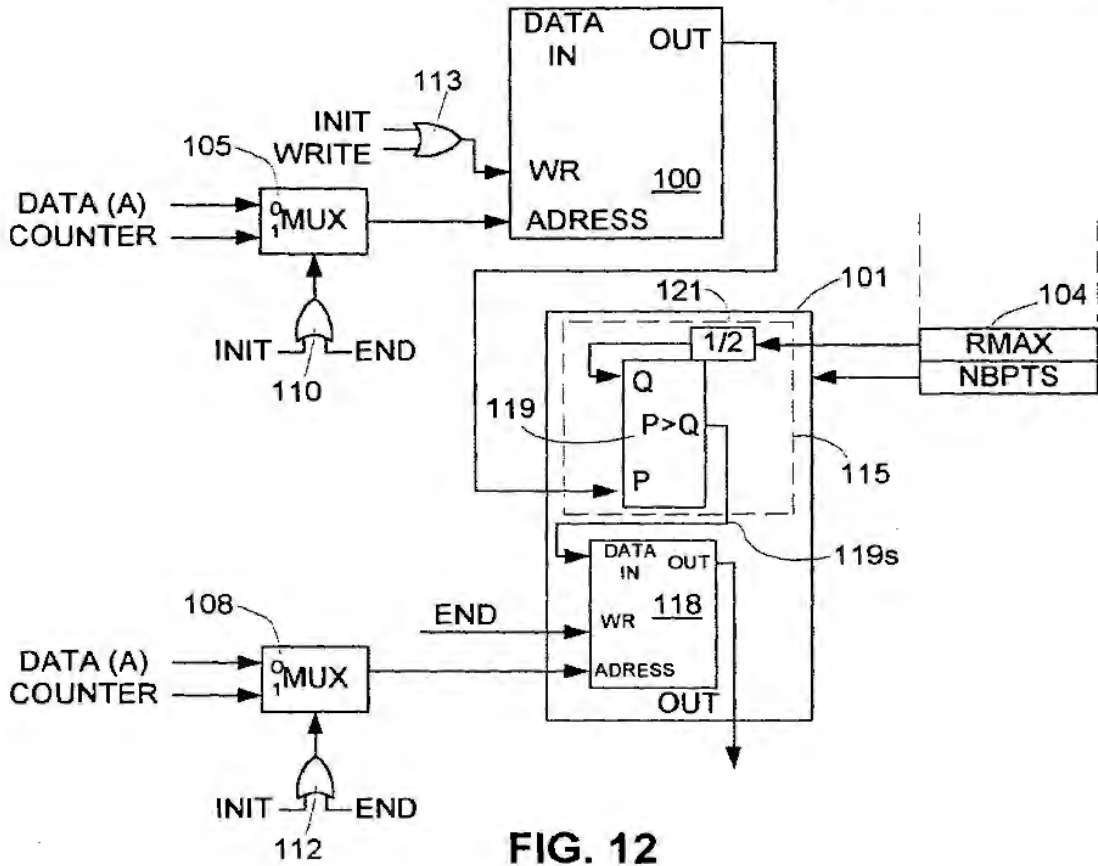

FIG. 12

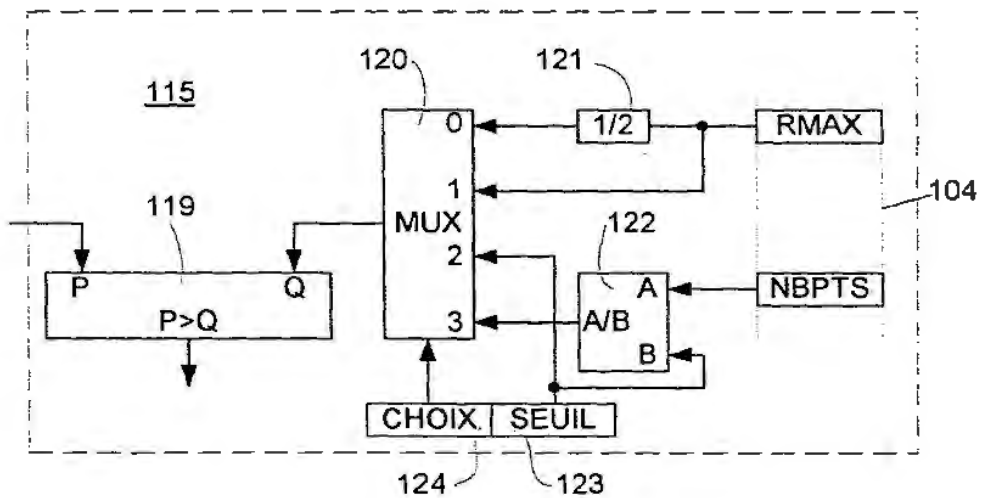

FIG. 13

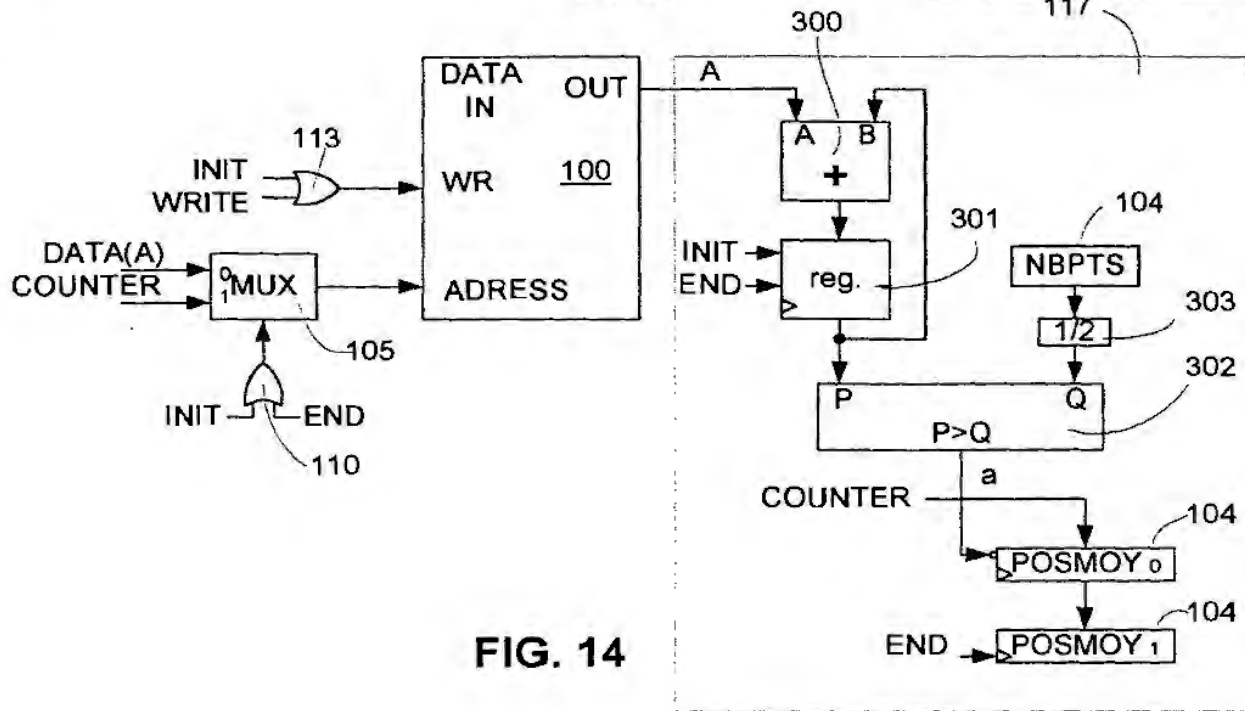

FIG. 14

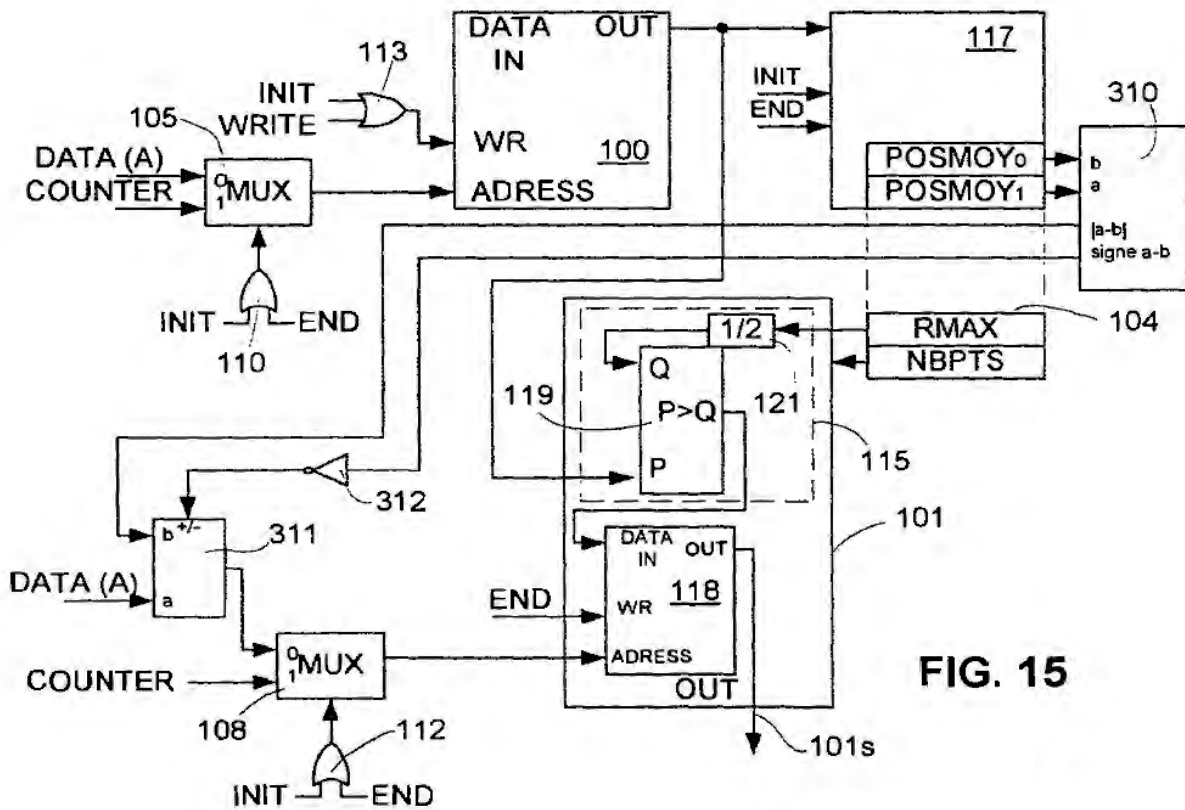

FIG. 15

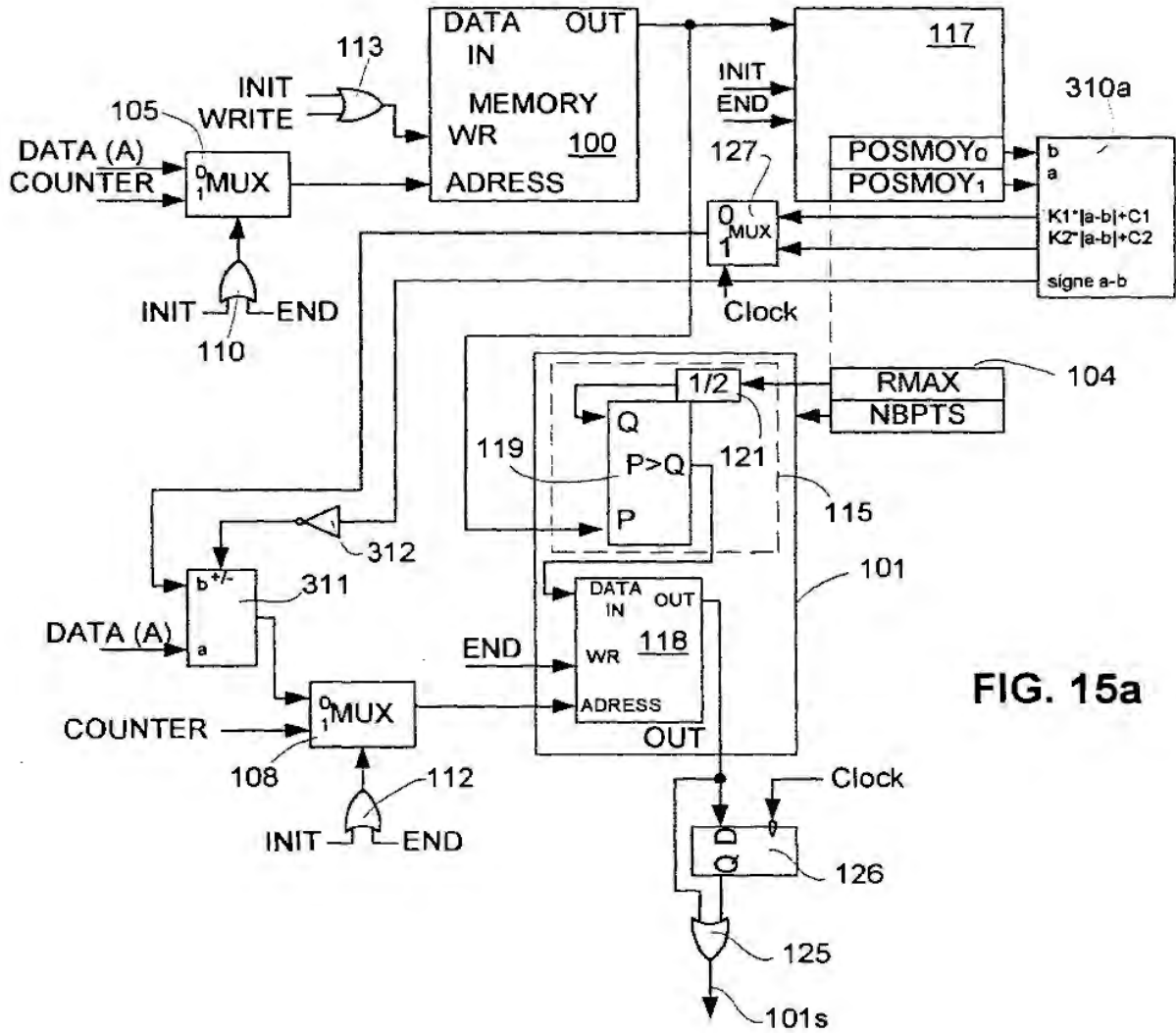

FIG. 15a

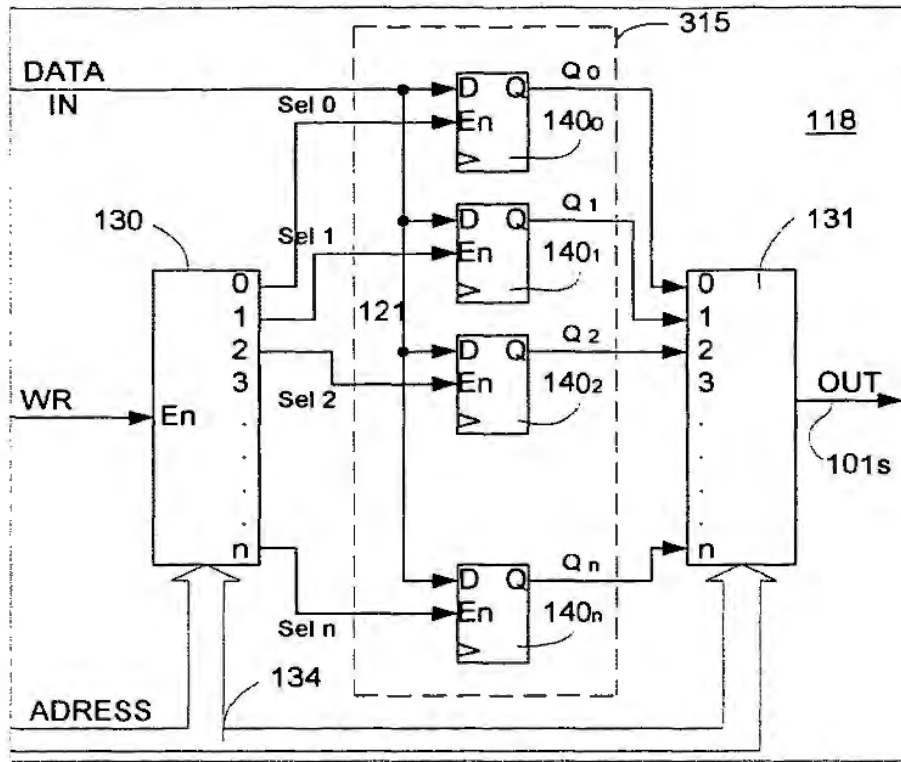

FIG. 16

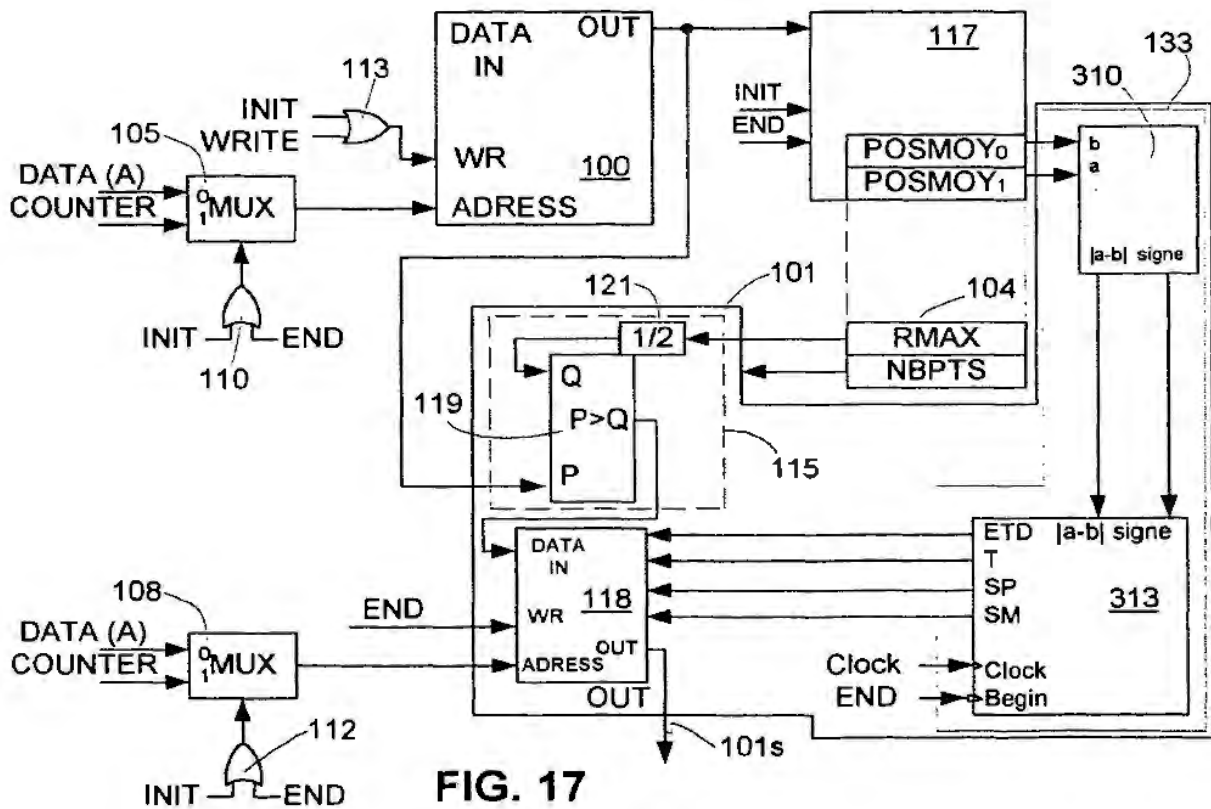

FIG. 17

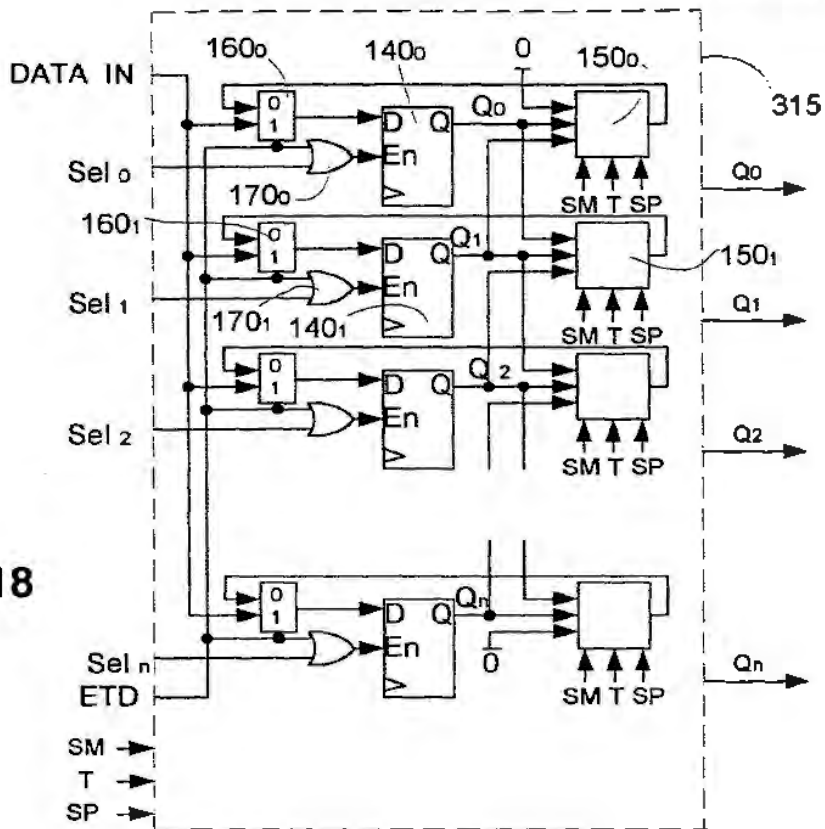

FIG. 18

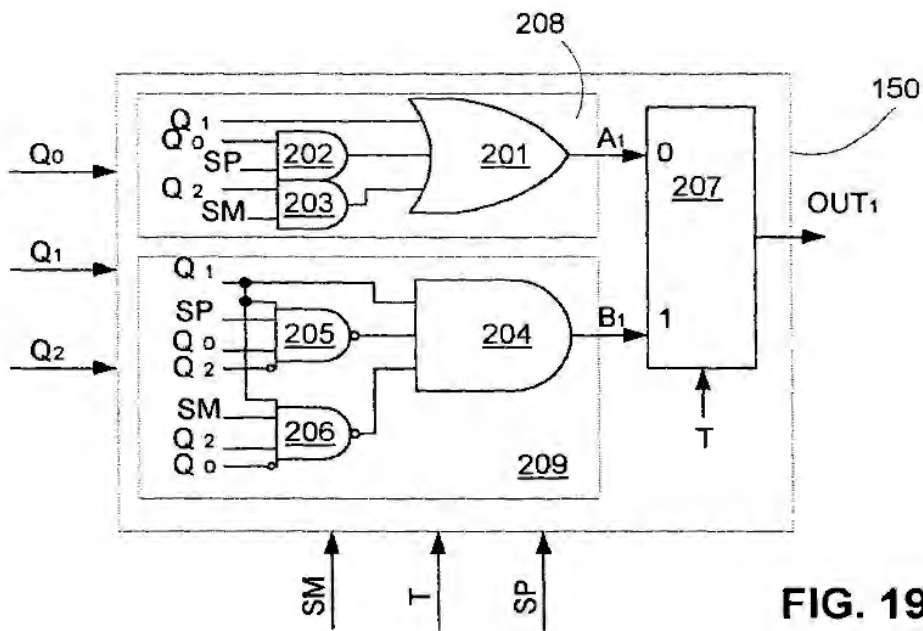

FIG. 19

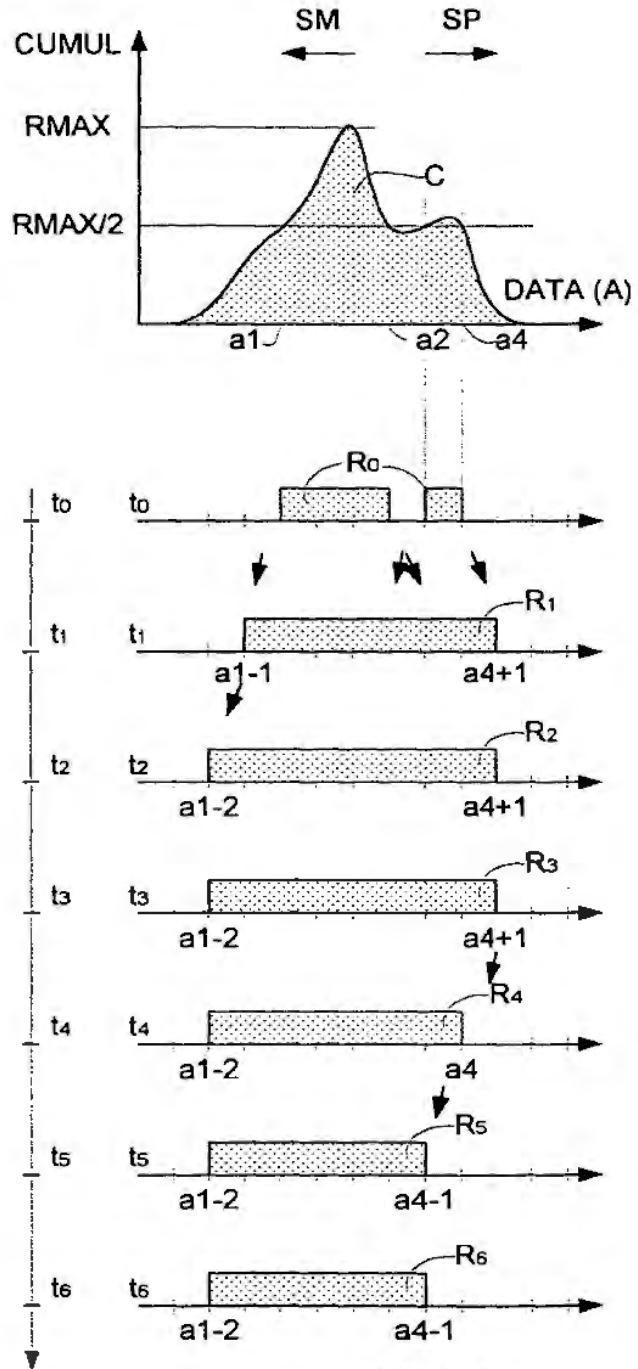
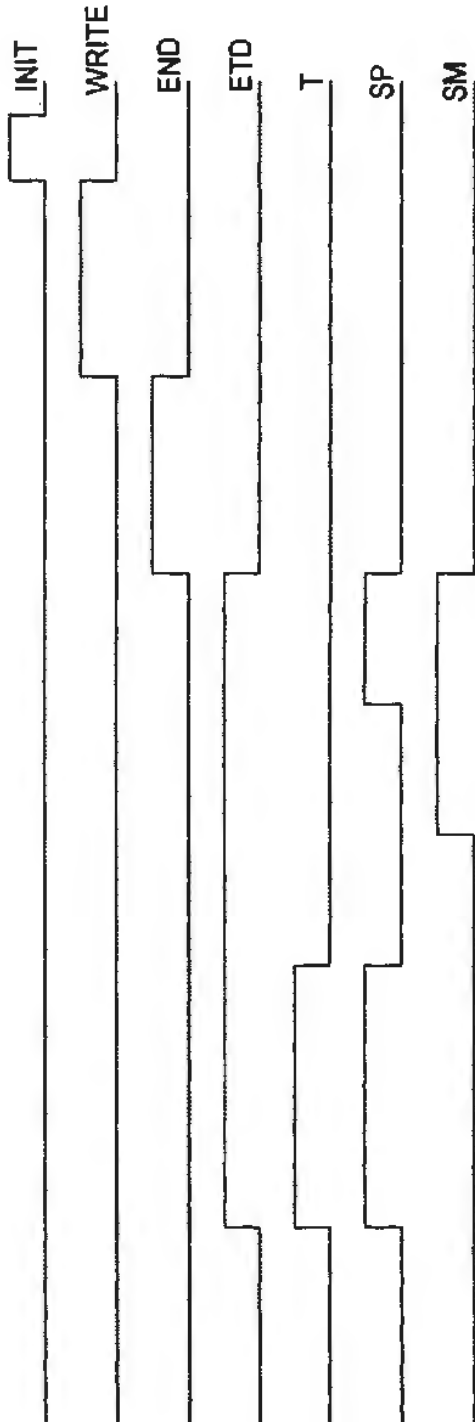

FIG. 20

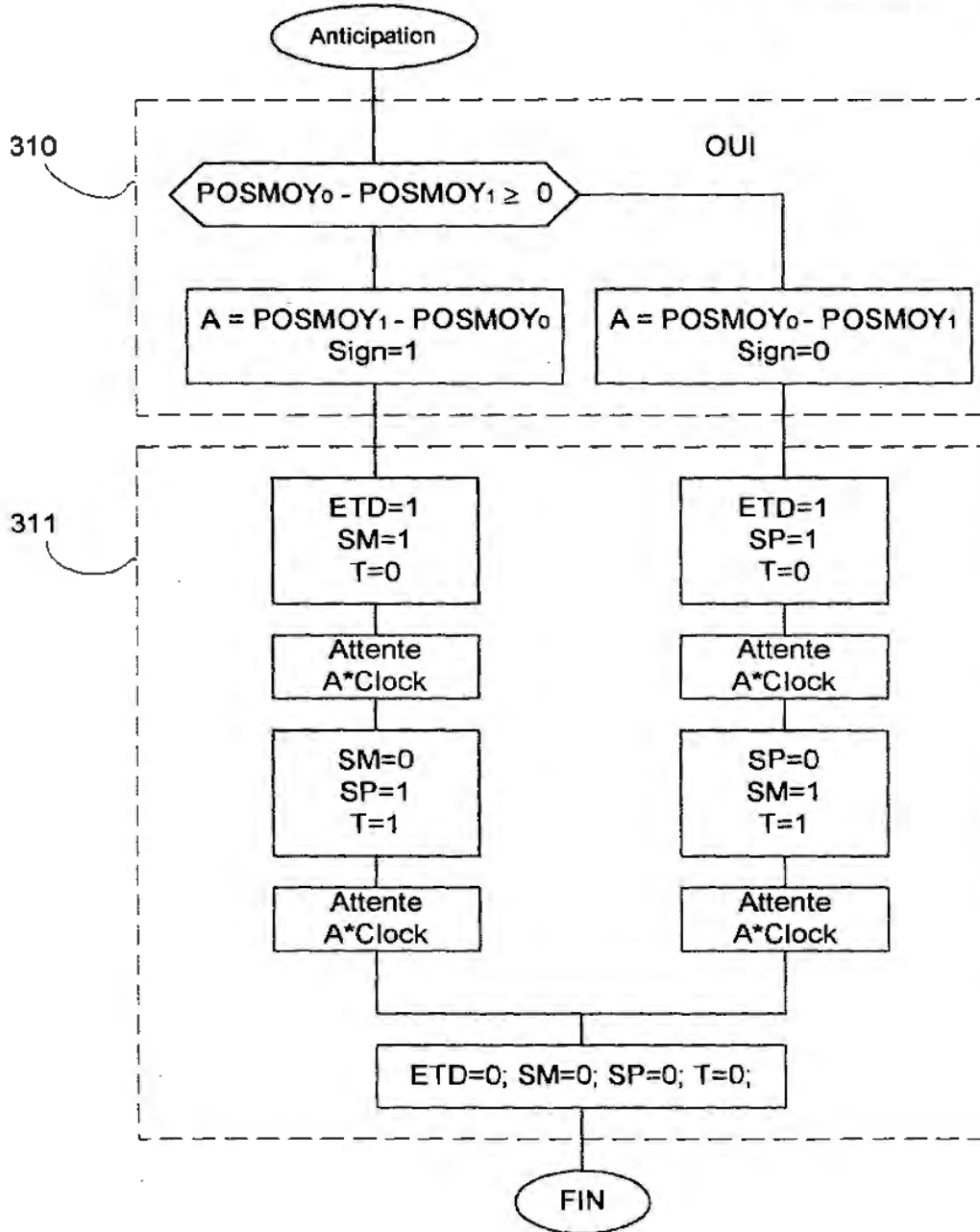

FIG. 21

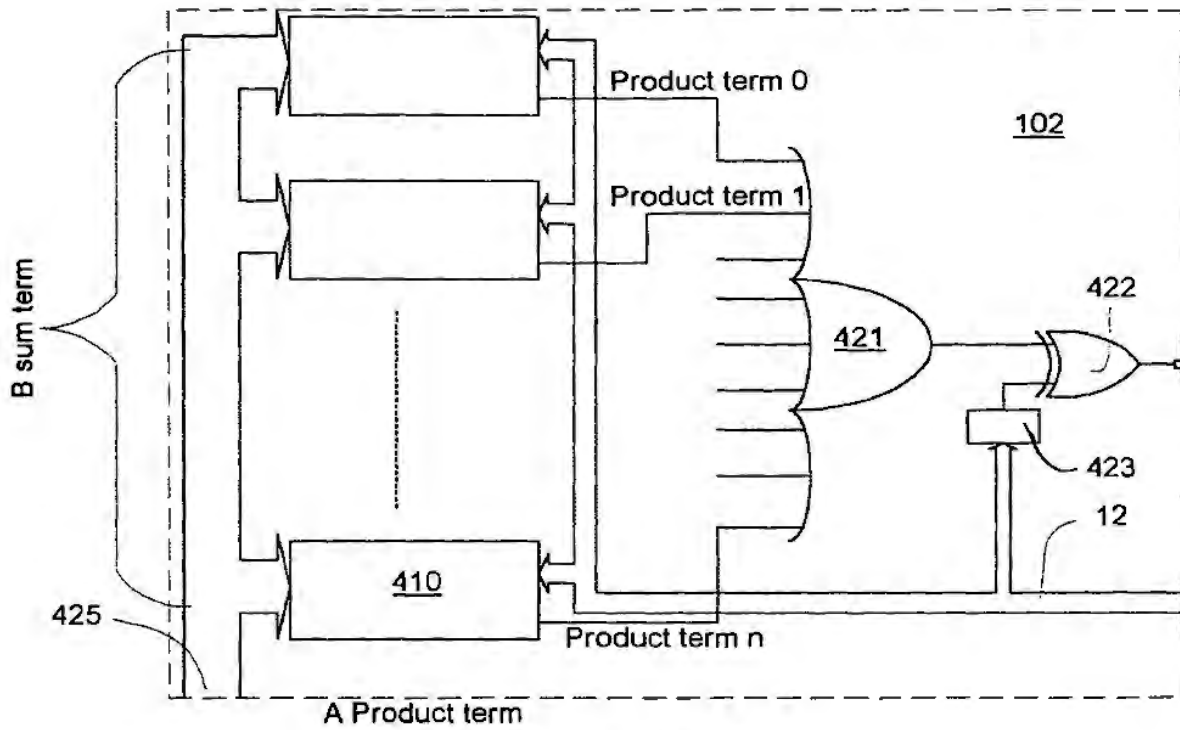

FIG. 22

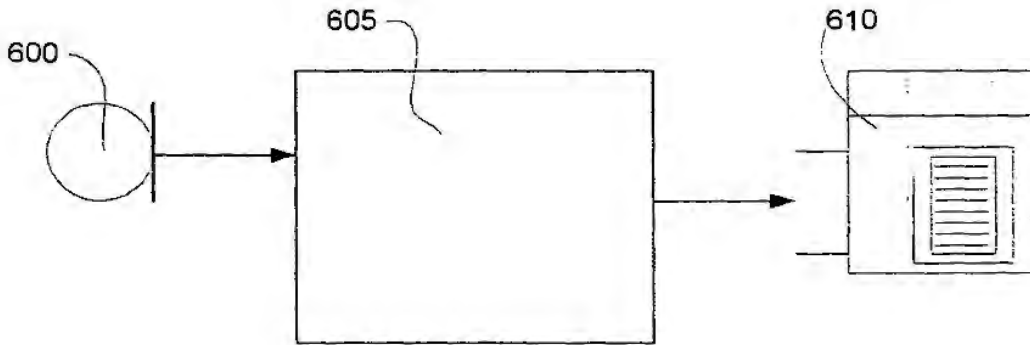

FIG. 39

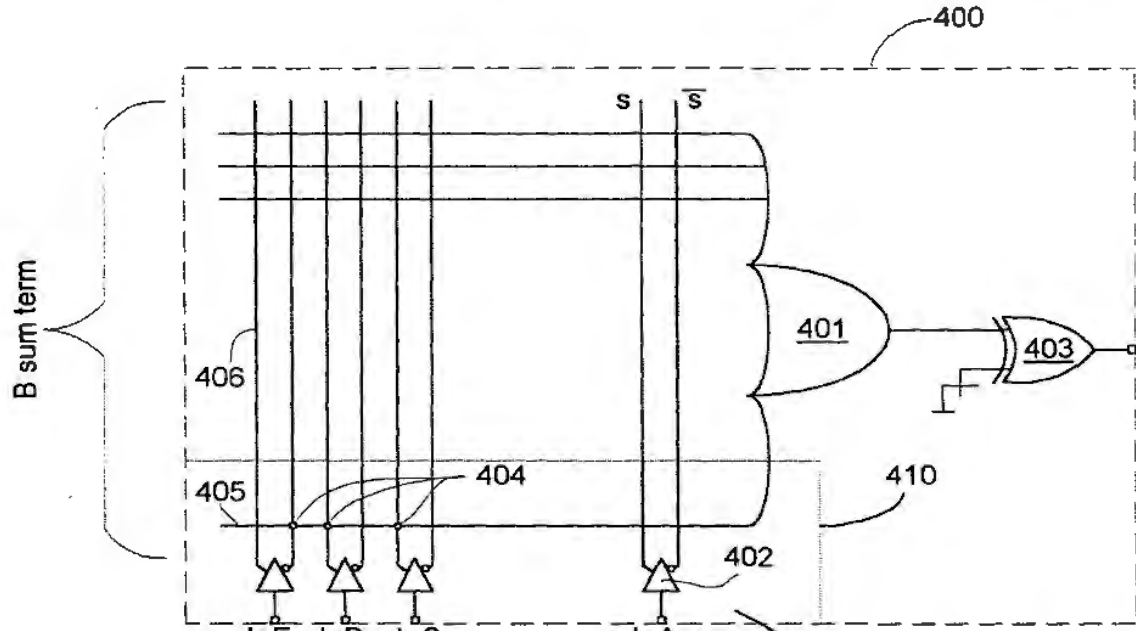

FIG. 23

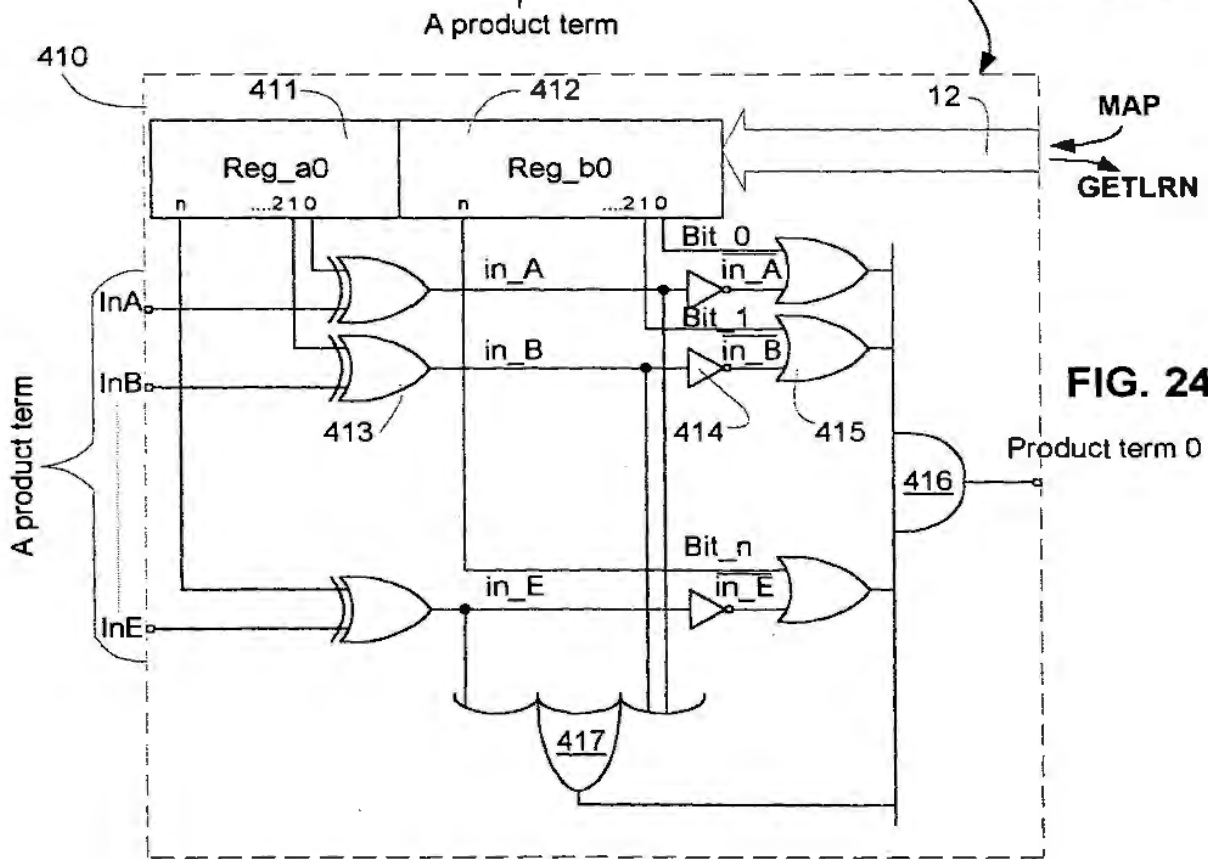

FIG. 24

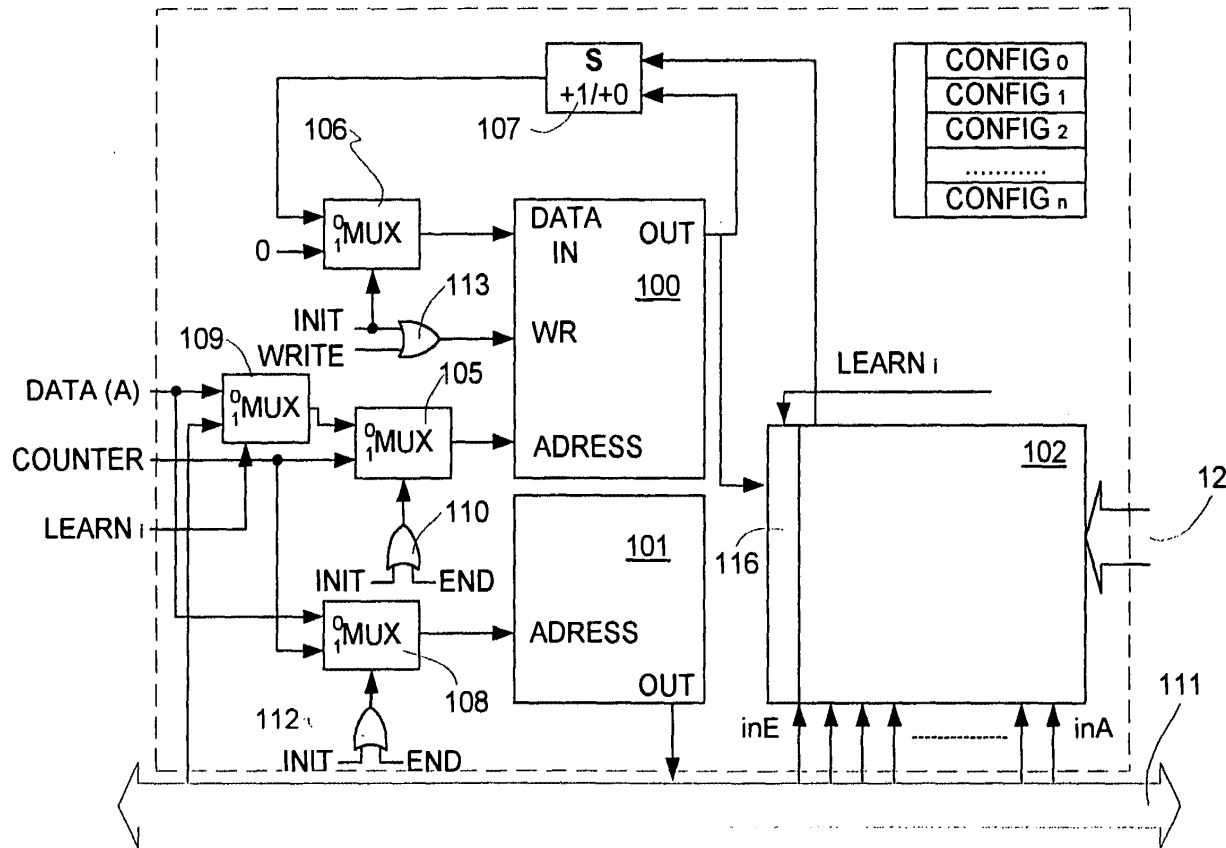

FIG. 25

18/26

ORIGINAL

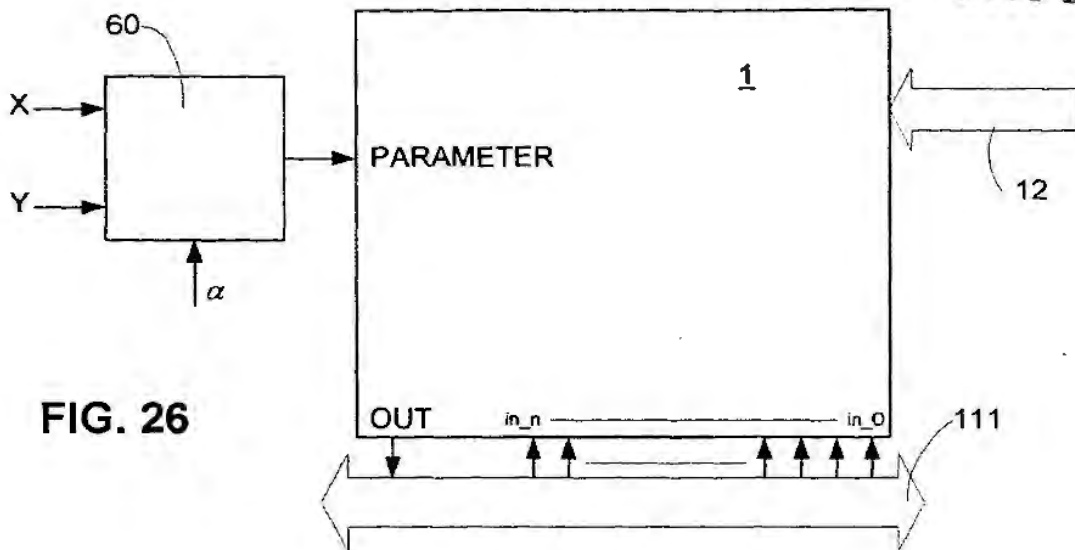

FIG. 26

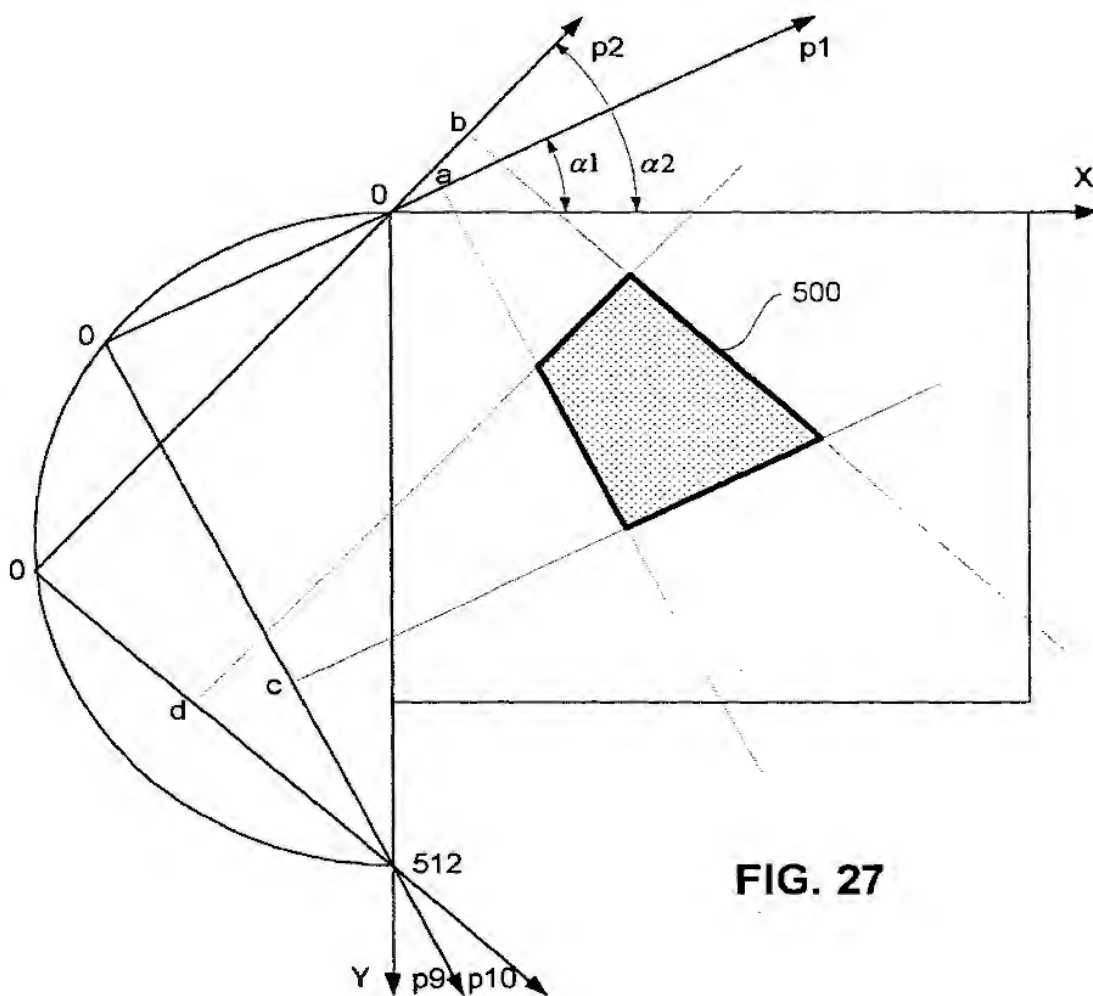

FIG. 27

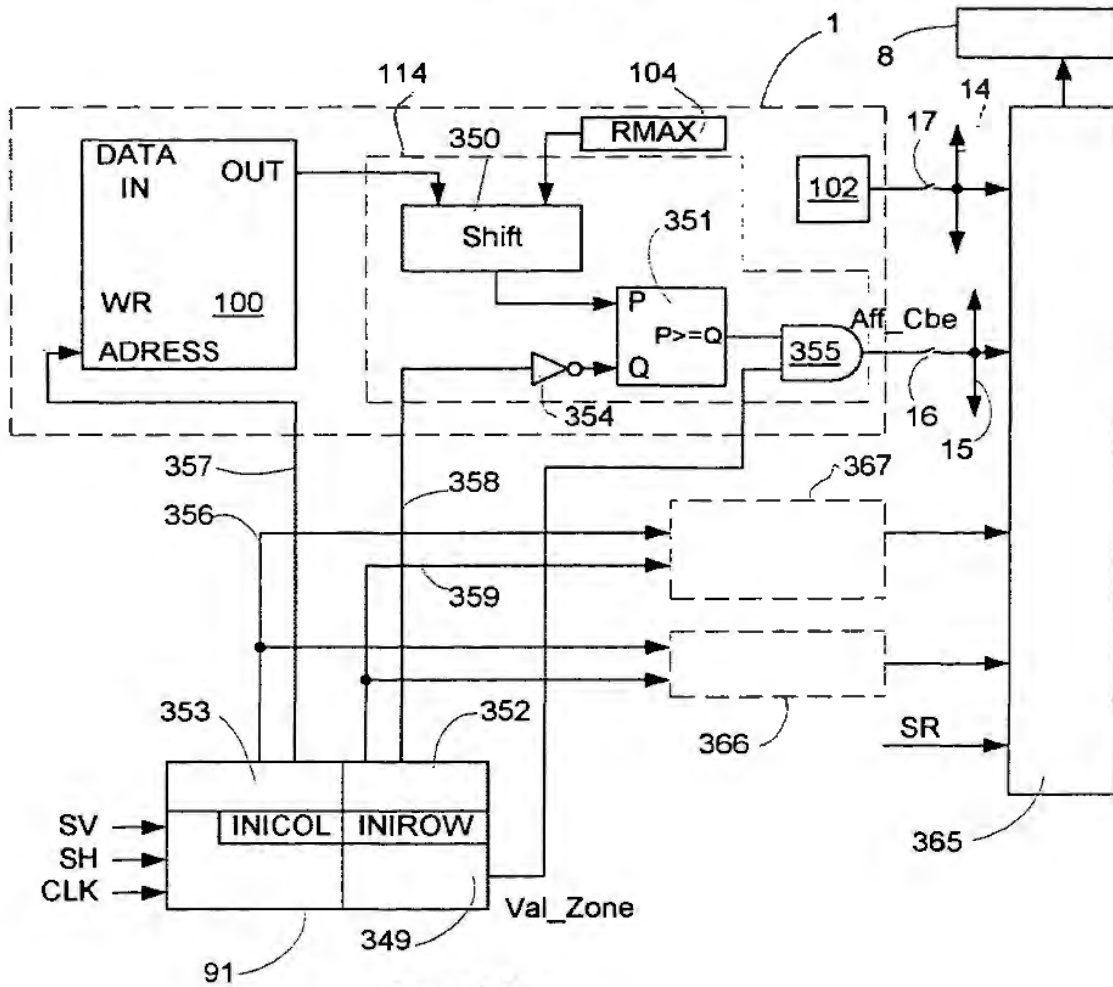

Fig. 28

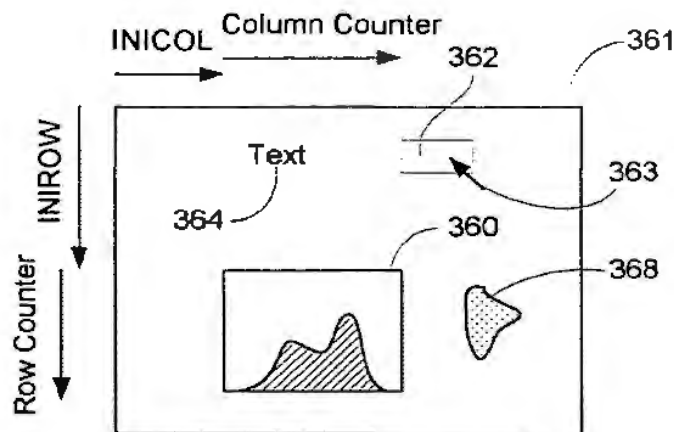

Fig. 29

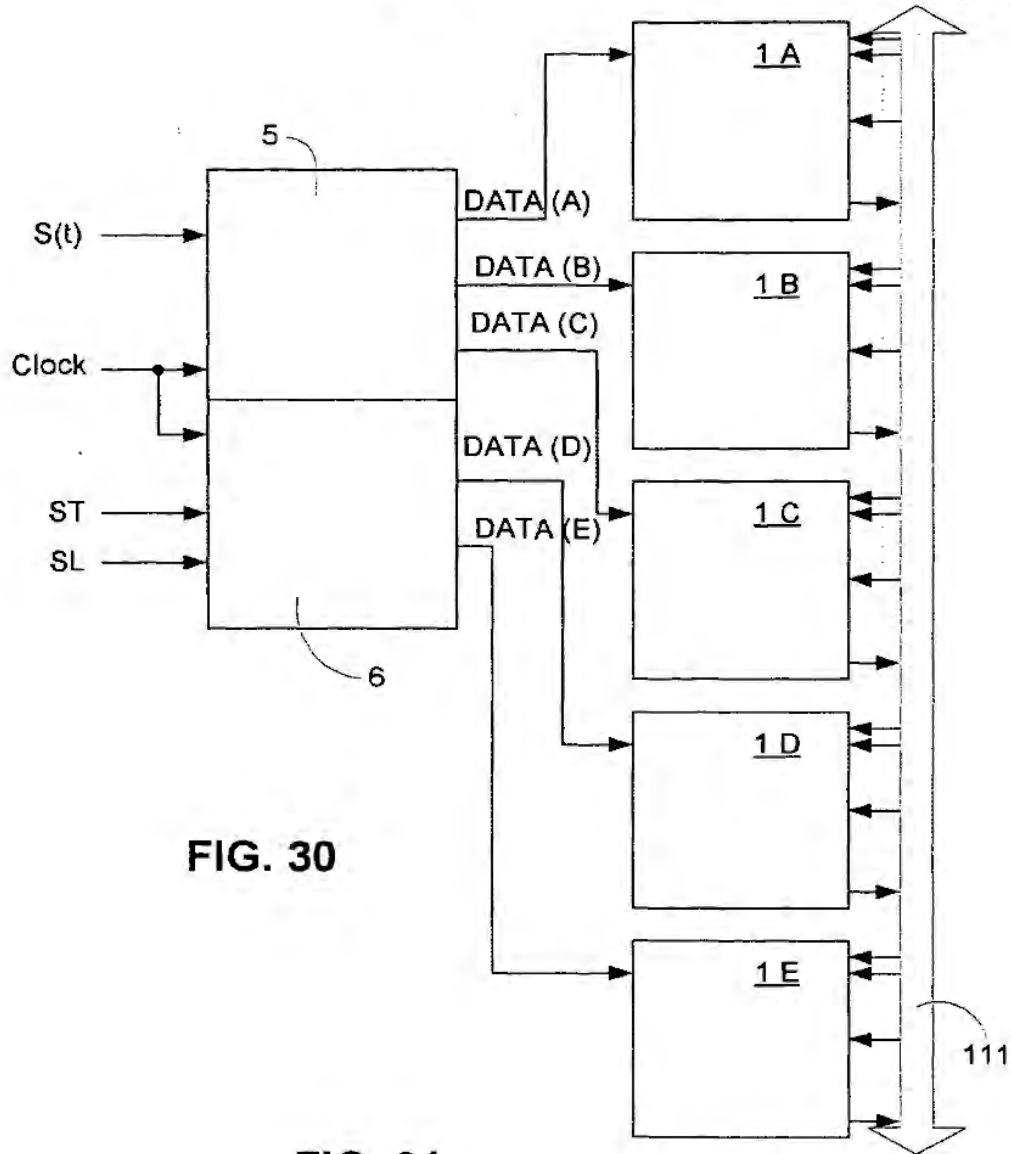
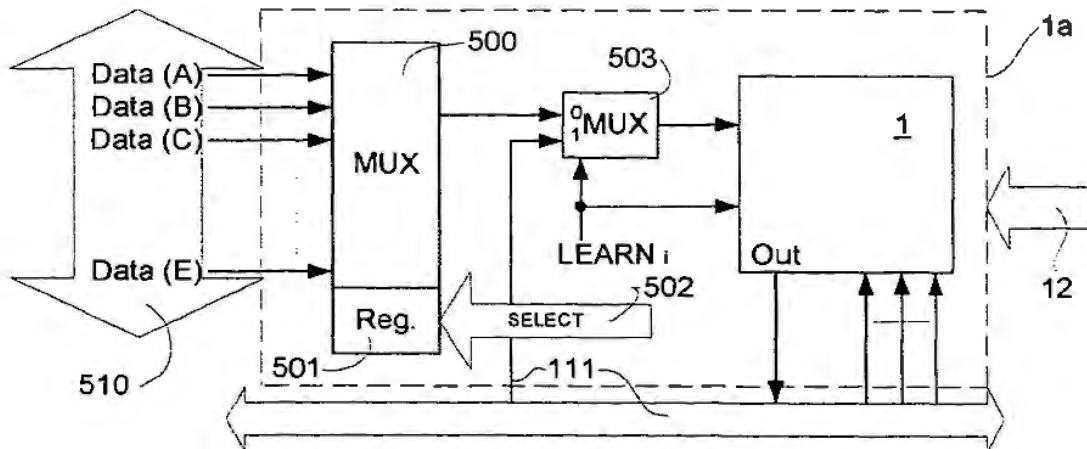

FIG. 30

FIG. 31



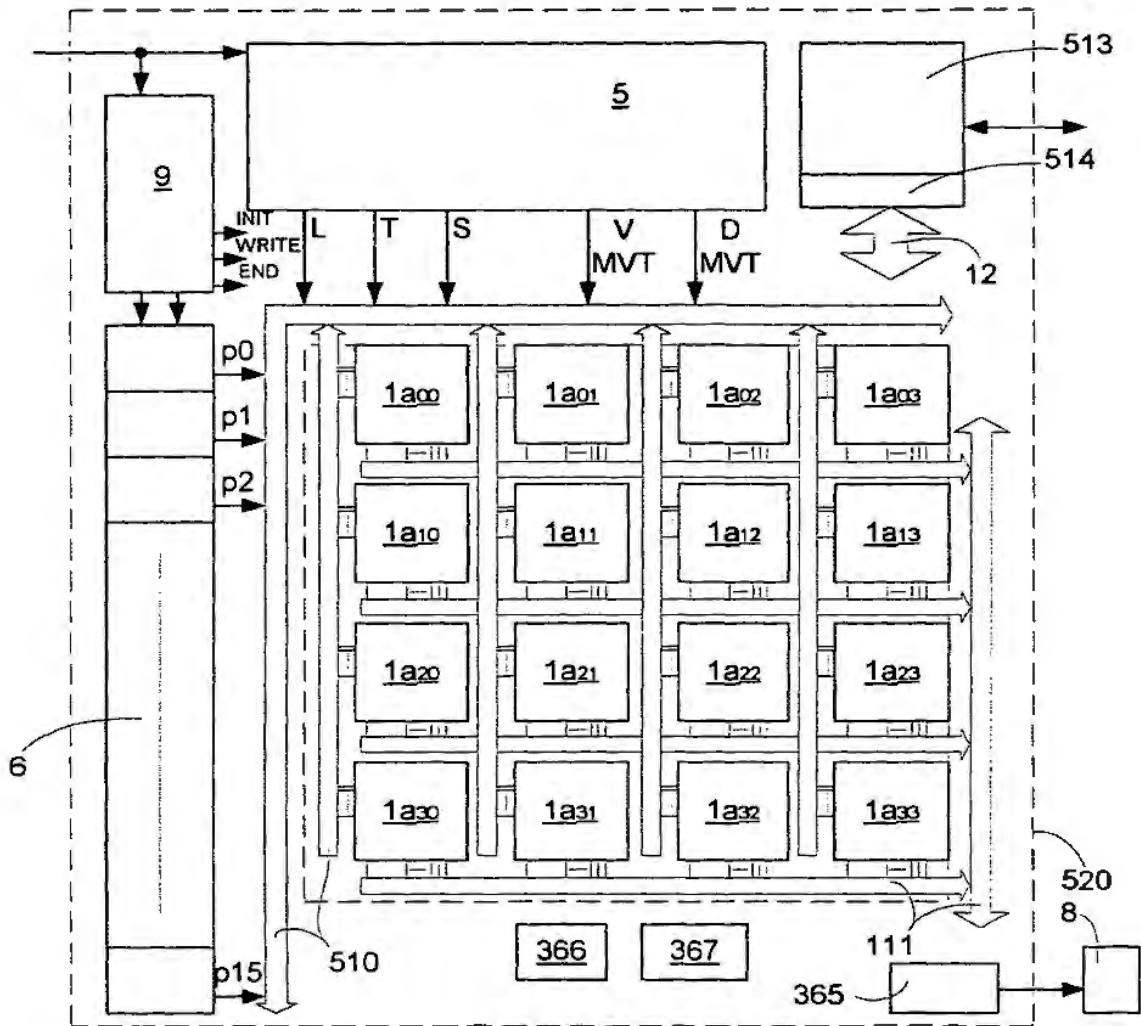

FIG. 32

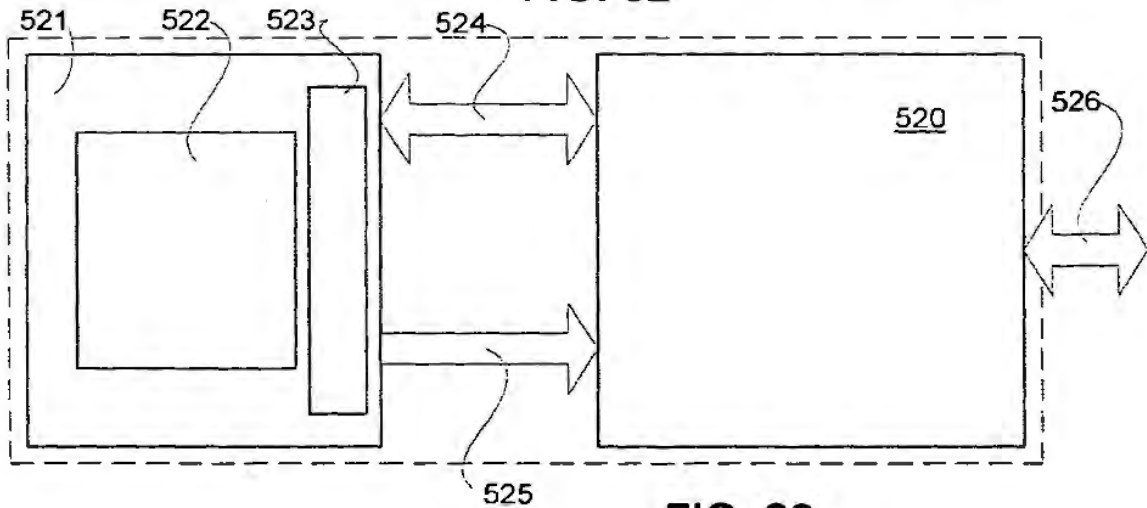
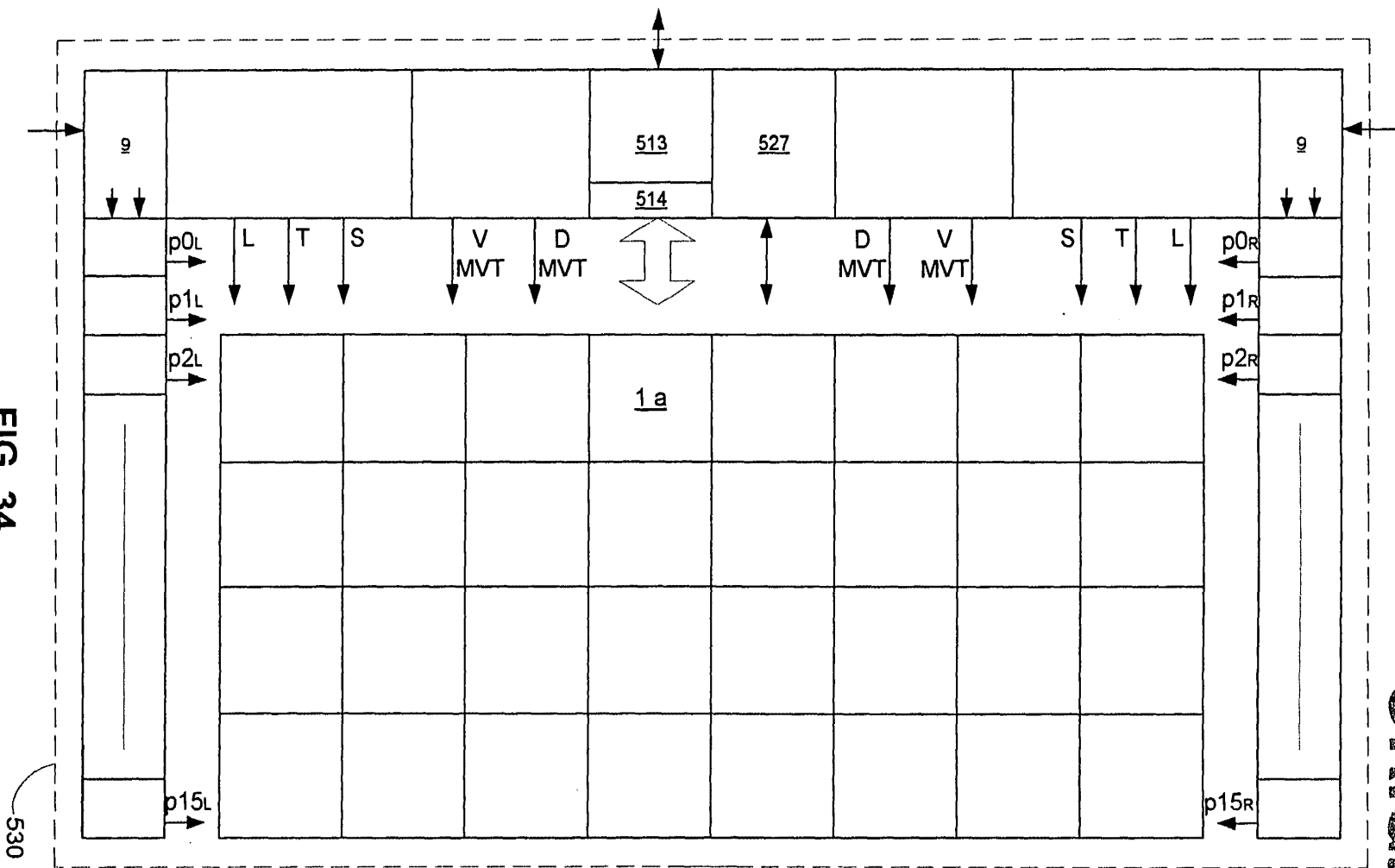

FIG. 33

FIG. 34



23/26

ORIGINAL

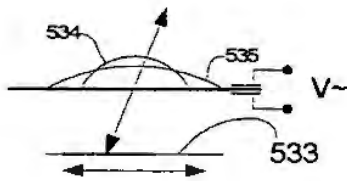
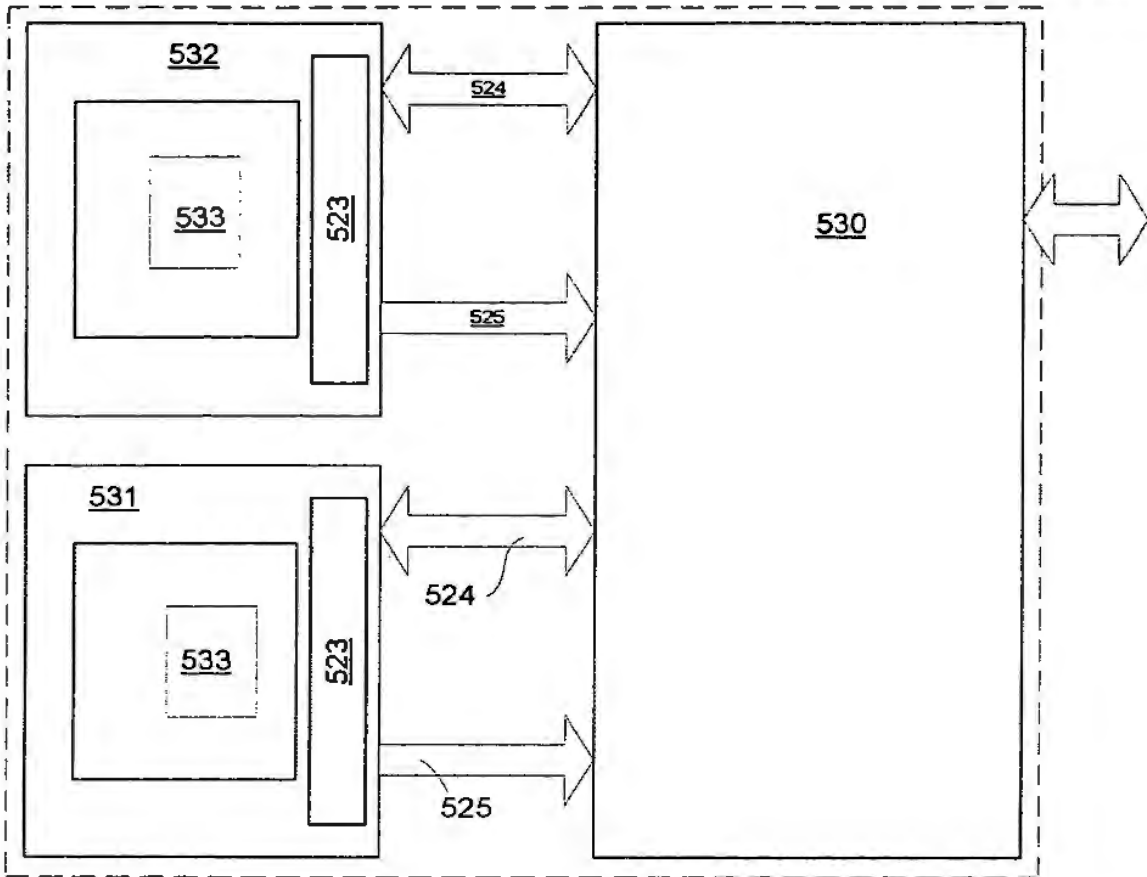
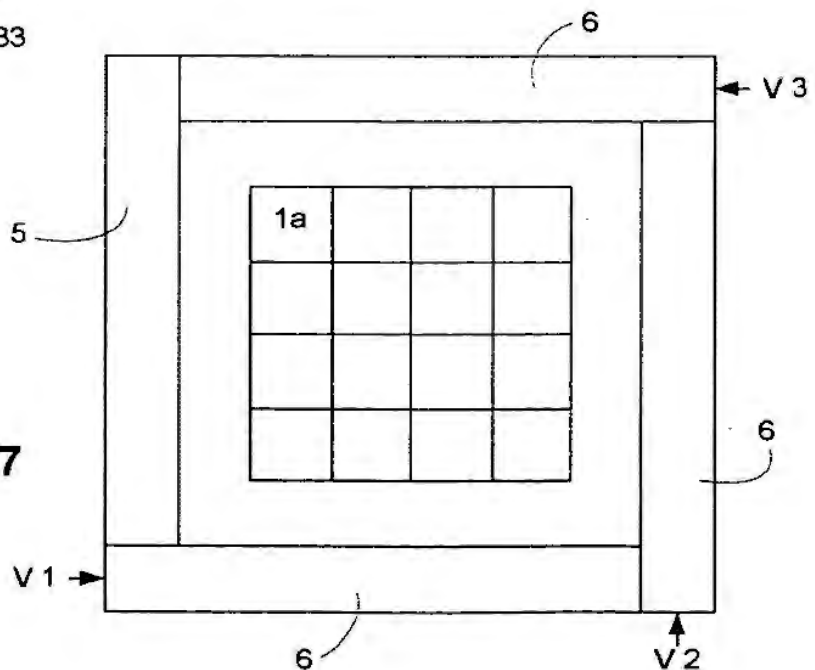

FIG. 36

FIG. 35

FIG. 37



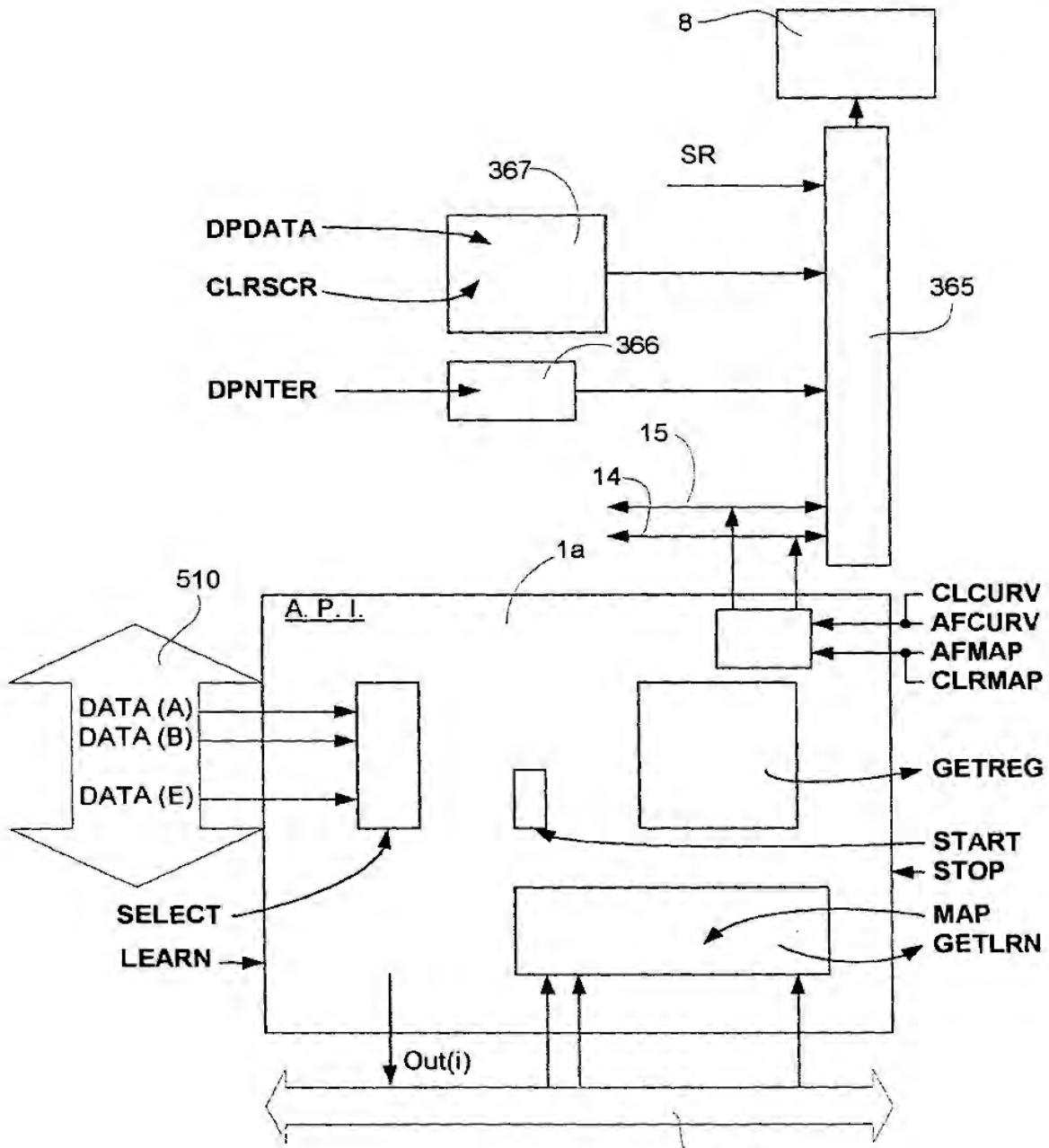

FIG. 38

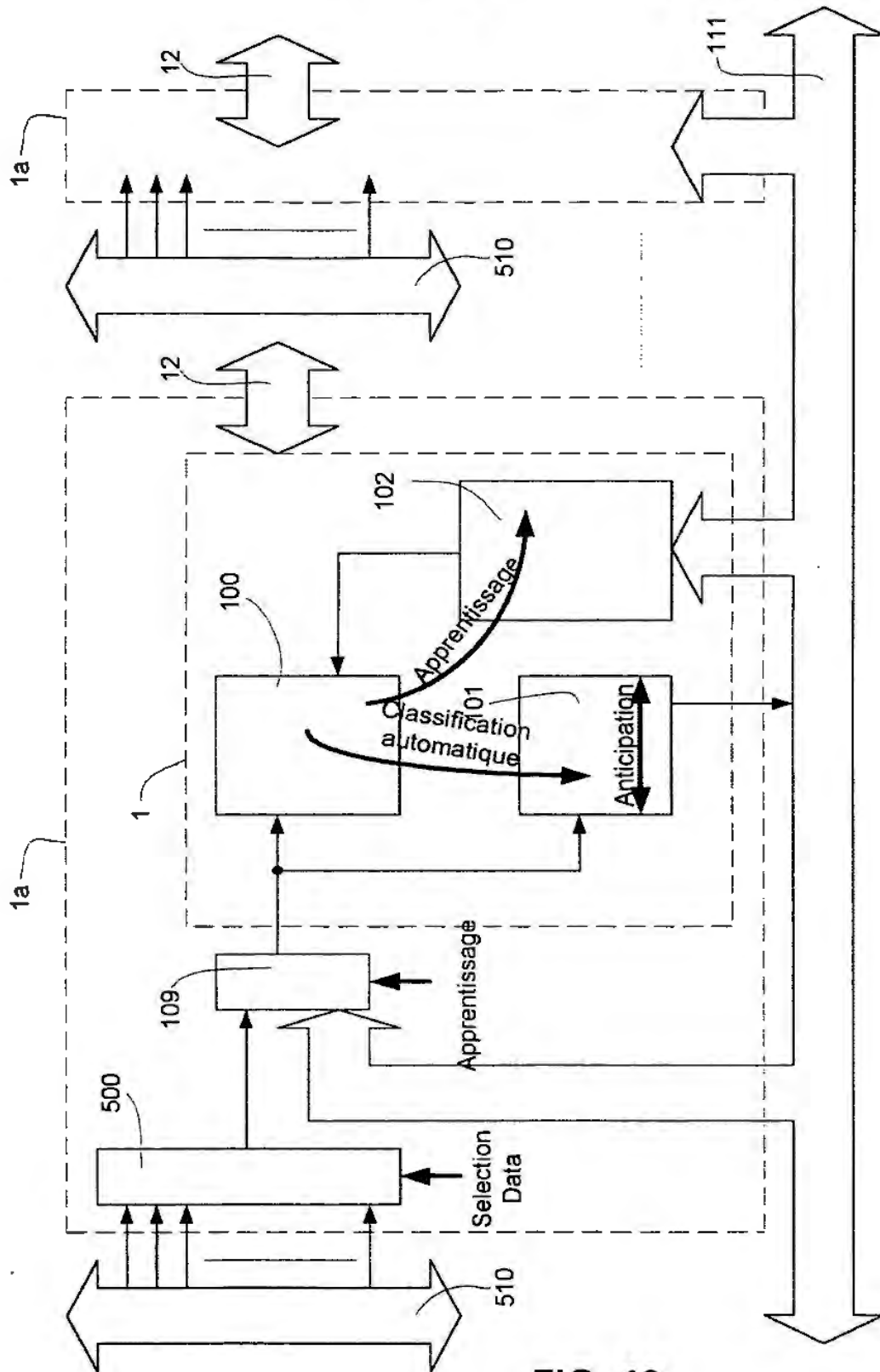

FIG. 40

THIS PAGE BLANK (USPTO)



FEE TRANSMITTAL for FY 2004

Effective 10/01/2003. Patent fees are subject to annual revision.

Applicant claims small entity status. See 37 CFR 1.27

TOTAL AMOUNT OF PAYMENT (\$) 524

Complete if Known

Application Number	09/792,436
Filing Date	February 23, 2001
First Named Inventor	Pirim, Patrick
Examiner Name	George B. Davis
Art Unit	2121
Attorney Docket No.	20046H-000100US

METHOD OF PAYMENT (check all that apply)

Check Credit Card Money Order Other None

Deposit Account:

Deposit Account Number: 20-1430

Deposit Account Name: Townsend and Townsend and Crew LLP

The Director is authorized to: (check all that apply)

Charge fee(s) indicated below Credit any overpayments

Charge any additional fee(s) or any underpayment of fee(s)

Charge fee(s) indicated below, except for the filing fee to the above-identified deposit account.

FEE CALCULATION

1. BASIC FILING FEE

Large Entity	Small Entity	Fee Code	Fee (\$)	Fee Description	Fee Paid
		1001	770	2001 385 Utility filing fee	
		1002	340	2002 170 Design filing fee	
		1003	530	2003 285 Plant filing fee	
		1004	770	2004 385 Reissue filing fee	
		1005	160	2005 80 Provisional filing fee	
SUBTOTAL (1)					(\$)

2. EXTRA CLAIM FEES FOR UTILITY AND REISSUE

Total Claims	Extra Claims	Fee from below	Fee Paid
29	-28** = 1	X\$18	\$18
7	-6** = 1	X\$86	\$86
Multiple Dependent	X		

Large Entity	Small Entity	Fee Code	Fee (\$)	Fee Description
		1202	18	2202 9 Claims in excess of 20
		1201	86	2201 43 Independent claims in excess of 3
		1203	290	2203 145 Multiple dependent claim, if not paid
		1204	86	2204 43 ** Reissue independent claims over original patent
		1205	18	2205 9 ** Reissue claims in excess of 20 and over original patent

SUBTOTAL (2) (\$104)

**or number previously paid, if greater; For Reissues, see above

FEE CALCULATION (continued)

3. ADDITIONAL FEES

Large Entity	Small Entity	Fee Code	Fee (\$)	Fee Description	Fee Paid
		1051	130	2051 65 Surcharge - late filing fee or oath	
		1052	50	2052 25 Surcharge - late provisional filing fee or cover sheet.	
		1053	130	1053 130 Non-English specification	
		1812	2,520	1812 2,520 For filing a request for reexamination	
		1804	920*	1804 920* Requesting publication of SIR prior to Examiner action	
		1805	1,840*	1805 1,840* Requesting publication of SIR after Examiner action	
		1251	110	2251 55 Extension for reply within first month	
		1252	420	2252 210 Extension for reply within second month	420
		1253	950	2253 475 Extension for reply within third month	
		1254	1,480	2254 740 Extension for reply within fourth month	
		1255	2,010	2255 1,005 Extension for reply within fifth month	
		1401	330	2401 165 Notice of Appeal	
		1402	330	2402 165 Filing a brief in support of an appeal	
		1403	290	2403 145 Request for oral hearing	
		1451	1,510	1451 1,510 Petition to institute a public use proceeding	
		1452	110	2452 55 Petition to revive - unavoidable	
		1453	1,330	2453 665 Petition to revive - unintentional	
		1501	1,330	2501 665 Utility issue fee (or reissue)	
		1502	480	2502 240 Design issue fee	
		1503	640	2503 320 Plant issue fee	
		1460	130	1460 130 Petitions to the Commissioner	
		1807	50	1807 50 Petitions related to provisional applications	
		1808	180	1808 180 Submission of Information Disclosure Statement	
		8021	40	8021 40 Recording each patent assignment per property (times number of properties)	
		1809	770	2809 385 Filing a submission after final rejection (37 CFR § 1.129(a))	
		1810	770	2810 385 For each additional invention to be examined (37 CFR § 1.129(b))	
		1801	770	2801 385 Request for Continued Examination (RCE)	
		1802	900	1802 900 Request for expedited examination of a design application	

Other fee (specify)

*Reduced by Basic Filing Fee Paid SUBTOTAL (3) (\$420)

SUBMITTED BY

Name (Print/Type)	Gerald T. Gray	Registration No. (Attorney/Agent)	41,797	Telephone	925-472-5000
Signature	<i>Gerald T. Gray</i>			Date	August 26, 2004

WARNING: Information on this form may become public. Credit card information should not be included on this form. Provide credit card information and authorization on PTO-2038.



I hereby certify that this correspondence is being deposited with the United States Postal Service as first class mail in an envelope addressed to:

Commissioner for Patents
P.O. Box 1450
Alexandria, VA 22313-1450

On August 26, 2004

TOWNSEND and TOWNSEND and CREW LLP

By: Sylvia E. Arnold
Sylvia E. Arnold

PATENT
Attorney Docket No.: 20046H-000100US
Client Ref. No.: 308L US 3772

IN THE UNITED STATES PATENT AND TRADEMARK OFFICE

In re application of:

Patrick Pirim

Application No.: 09/792,436

Filed: February 23, 2001

For: METHOD AND DEVICE FOR
AUTOMATIC VISUAL PERCEPTION

Customer No.: 20350

Confirmation No. 9956

Examiner: George B. Davis

Technology Center/Art Unit: 2122

AMENDMENT

09/01/2004 WASFAW1 00000042 201430 09792436
01 FC:1201 86.00 DA
02 FC:1202 18.00 DA

Commissioner for Patents
P.O. Box 1450
Alexandria, VA 22313-1450

Sir:

In response to the Office Action mailed March 26, 2004, please enter the following amendments and remarks:

Amendments to the Specification begin on page 2 of this paper.

Amendments to the Claims are reflected in the listing of claims which begins on page 7 of this paper.

Amendments to the Drawings begin on page 16 of this paper and include both an attached replacement sheet and an annotated sheet showing changes.

Remarks/Arguments begin on page 17 of this paper.

An **Appendix** including amended drawing figures is attached following page 17 of this paper.

Amendments to the Specification:

Please amend the paragraph beginning at page 7, line 6 as follows:

- Figures ~~13 and 13e~~ 13a and 13d are representations of an enabling counter fitted with several adapting modules according to alternate embodiments of the present invention;

Please amend the paragraph beginning at page 7, line 8 as follows:

- Figures ~~13a and 13b~~ 13b and 13c are representations of statistical distributions of a parameter and classification criteria;

Please amend the paragraph beginning at page 7, line 12 as follows:

- Figure ~~[[15]]~~ 15a is a diagram representing the elements of a self-adapting histogram calculation unit with anticipation according to a first embodiment;

Please amend the paragraph beginning at page 7, line 14 as follows:

- Figure ~~[[15a]]~~ 15b is a diagram representing the elements of a self-adapting histogram calculation unit with anticipation according to an alternate embodiment;

Please amend the paragraph beginning at page 8, line 17 as follows:

- Figure ~~[[31]]~~ 31a is the representation of the use of a single programmable histogram calculation unit with a multiplexer enabling the calculation unit to process any of a number of parameters according to one embodiment of the present invention;

Please amend the paragraph beginning at page 8, line 20 as follows:

- Figure ~~[[31a]]~~ 31b is a representation of a histogram calculation unit called as well an electronic spatio-temporal neuron;

Please amend the paragraph beginning at page 19, line 2 as follows:

Figure ~~[[13]]~~ 13a represents an alternative embodiment of the classifier 101 including a multiplexer 120 that is controlled by a selection control signal 124. Classifier 101 enables comparison of the parameter P to a statistical value Q, which can be prepared in various ways in relation to the statistical parameters received on the different inputs 0, 1, 2, 3 of multiplexer 120,

which are selected by the selection control signal 124, which depends on the content of the register 'SELECTION'. The input 0 of the multiplexer 120 receives the value $RMAX/2$ produced on the basis of the data in the analysis output register 104 by the divider circuit 121, the input 1 of the multiplexer 120 receives directly the value $RMAX$, the input 2 of the multiplexer 120 receives a threshold value contained in a register 'THRESHOLD' 123 whose content is programmed outside the system, and the input 3 of multiplexer 120 receives the quotient of the number of points $NBPTS$ by the $THRESHOLD$ 123 produced by the divider circuit 122.

Please amend the paragraph beginning at page 19, line 14 as follows:

Therefore, as represented on Figure [[13]] 13a, the parameter P can be compared to the respective values $RMAX/2$, $RMAX$, at a threshold B input from the outside and in proportion to the number of points $NBPTS$ attached to this threshold by the divider 122. It will be apparent that other input values may be used, e.g., any values from registers 104.

Please amend the paragraph beginning at page 19, line 23 as follows:

~~Figures 13a, 13b, 13c~~ represents 13b, 13c and 13d represent another embodiment of a classifier in which the cumulative total of events is used in a histogram instead of the levels. The classification boundaries are defined, for example, by the use of a register $RMAX$, corresponding to a maximum of events for the analyzed parameter, and in searching for the parameter values for $RMAX/2$. On both sides of the $RMAX$ position, these values correspond to limit A and limit B of the classifier.

Please amend the paragraph beginning at page 19, line 29 as follows:

Hence, the $RMAX$ register such as it is operated in the second embodiment of the classifier, is replaced here by the register $NBPTS$, corresponding to the total cumulative result of events (Figure [[13a]] 13b). By removing a percentage k of $NBPTS$ on both sides of the histogram, the limits A and B become more stable (Figure [[13b]] 13c).

Please amend the paragraph beginning at page 20, line 1 as follows:

The device represented in Figure [[13c]] 13d carries out this function.

Please amend the paragraph beginning at page 20, line 2 as follows:

In Figure [[13c]] 13d, the analysis memory 100 and the command of the address multiplexer 105 are present. The analysis output register 104 operates as described above using the number of points NBPTS 1041 and, in general, the limit A 1042 and the limit B 1043 as well.

Please amend the paragraph beginning at page 23, line 2 as follows:

Figure [[15]] 15a illustrates a circuit according to one embodiment that is configured to implement anticipation. The memory 118 is that described previously with reference to Figure 16.

Please amend the paragraph beginning at page 23, line 11 as follows:

Figure [[15a]] 15b illustrates a circuit according to an alternate embodiment that is configured to implement anticipation. In this embodiment, calculation unit 310a is similar to calculation unit 310, but with improved performance by providing different functionality with respect to the offset of the value of the parameter supplying memory 118. Calculation unit 310 of Figure [[15]] 15a provides an offset determined by a function of the form $y=x$, where x is $|\text{POSMOY}_0 - \text{POSMOY}_1| (P_0 - P_1)$. Calculation unit 310 of Figure 15a or 310a of Figure [[15]] 15b can provide for an offset determined by functions of the form $y=ax+b$, where a (e.g., k_1 and k_2) and b (e.g., c_1 and c_2) are adjustable constants provided, for example, by an on-chip controller. It will, of course, be apparent that any other function of the POSMOY values can be used as desired, such as $y=ax^2$. In one embodiment, for example, a multiplexer unit can be implemented to receive as input to the two functions of POSMOY, namely $k_1 * |P_0 - P_1| + c_1$ and $k_2 * |P_0 - P_1| + c_2$, and provides one as output based on the value of the control signal "Clock" to control translator 311.

Please amend the paragraph beginning at page 33, line 5 as follows:

In summary, as represented on Figure [[31a]] 31b, for the parameter A, each histogram calculation unit $1_A, 1_B, \dots, 1_E$ processes one of the data DATA(A), DATA(B), ..., DATA(E) by the corresponding function $(fog)_A \dots$ to produce individually an output value $(1015)_A \dots$ and all together, the time coincidence available on the bus 111. At the same time, the analysis output register 104_A is fed.

Please amend the paragraph beginning at page 33, line 13 as follows:

In the embodiment shown on Figure [[31]] 31a, the different parameters DATA(A) ... DATA(E) feed an input multiplexer 500 that is controlled by a register 501. The register 501 is updated by the command SELECT 502. In one embodiment, a learning multiplexer 503 is optionally provided for implementing the learning function as previously described. In this embodiment, It is thus possible to use a single histogram calculation unit 1 to process any of the different parameters A, B, C ... E that are addressed by a bus 510 in relation to the SELECT command 502. The controlled learning multiplexer 503 receives, according to the status of the learning command of the histogram calculation unit i , $LEARN_i$, either the time coincidences information transmitted by the bus 111, or the information originating from the input multiplexer 500. Figure 40 illustrates a functional block diagram of multiple histogram calculation units 1a (e.g., from Figure [[31]] 31a) according to an embodiment of the present invention. As shown, each histogram calculation unit 1a is connected to data bus 510, which provides the various parameters for processing, and to bus 11 which provides the classification signals 101s and the learning function signals to the various units 1a. Each histogram calculation unit 1a includes memory 100, classifier 101 and time coincidences unit 102, and each unit 1a is capable of implementing the automatic classification, anticipation and/or learning functionality as previously described herein. It will be apparent that multiple histogram calculation units 1 can be operating in the operation mode while one or several of the remaining histogram calculation units 1 are operating in the learning mode.

Please amend the paragraph beginning at page 34, line 3, as follows:

In one embodiment, a histogram calculation unit is time-shared among different parameters during each frame. For example, with reference to Figure [[31]] 31a, histogram calculation unit

Appl. No. 09/792,436
Amdt. dated August 26, 2004
Reply to Office Action of March 26, 2004

PATENT

1 according to this embodiment calculates histograms and associated statistics for two or more parameters (e.g., Data (A) and Data (C)) during each frame. Multiplexer 500, in this embodiment, is capable of time multiplexing the various parameters. In this manner, fewer histogram calculation units are needed for processing the desired parameters, thereby reducing the amount of silicon required for producing the required number of histogram calculation units.

Amendments to the Claims:

This listing of claims will replace all prior versions, and listings of claims in the application:

Listing of Claims:

1 1. (Currently Amended) A visual perception processor for automatically
2 detecting an event occurring in a multidimensional space (i,j) evolving over time with respect to
3 at least one digitized parameter in the form of a digital signal on a data bus, said digital signal
4 being in the form of a succession a_{ijT} of binary numbers associated with synchronization signals
5 enabling to define a given instant (T) of the multidimensional space and the position (i,j) in this
6 space, the visual perception processor comprising:

7 [[a]] the data bus;
8 a control unit
9 a time coincidences bus carrying at least a time coincidence signal; and
10 at least two or more histogram calculation units for the treatment of the at least
11 one parameter, that receive the data DATA(A), DATA(B),... DATA(E) via the data bus and
12 supply classification information to the single time coincidences bus
13 the histogram calculation units being configured to form a histogram
14 representative of the parameter as a function of a validation signal and to determine by
15 classification a binary classification signal resulting from a comparison of the parameter and a
16 selection criterion C, wherein the classification signal is sent to the time coincidences bus, and
17 wherein the validation signal is produced from time coincidences signals from the time
18 coincidence bus so that the calculation of the histogram depends on the classification signals
19 carried by the time coincidence bus.

1 2. (Currently Amended) A visual perception processor according to claim 1,
2 further comprising, to process several parameters, several histogram calculation units organized
3 into a matrix, wherein each of the calculation units is connected to the data bus and to the time
4 coincidences bus wherein the histogram calculation units are organized into a matrix.

1 3. (Currently Amended) A visual perception processor, comprising:
2 ~~according to claim 1,~~
3 a data bus;
4 a time coincidences bus; and
5 two or more histogram calculation units that receive the data DATA(A),
6 DATA(B),... DATA(E) via the data bus and supply classification information to the single time
7 coincidences bus,
8 wherein at least one of said two or more histogram calculation unit processes data
9 a_{ijT} associated with pixels forming together a multidimensional space (i, j) evolving over with the
10 ~~course of~~ time and represented at a succession of instants (T), wherein said data reaches said at
11 least one calculation unit in the form of a digital signal DATA(A) in the form of a succession a_{ijT}
12 of binary numbers of n bits associated with synchronization signals enabling to define the given
13 instant (T) of the multidimensional space and the position (i, j) of the ~~pixel~~ pixels in this space, to
14 which the signal a_{ijT} received at a given instant (T) is associated, said unit comprising:
15 an analysis memory including a memory with addresses, each address
16 associated with possible values of the numbers of n bits of the signal DATA(A) and whose
17 writing process is controlled by a WRITE signal;
18 a classifier unit comprising a memory intended for receiving a selection
19 criterion C of the parameter DATA(A), said classifier unit receiving the signal DATA(A) at the
20 input and outputting a binary output signal having a value that ~~the value of which~~ depends on
21 ~~[[the]]~~ a result of the comparison of the signal DATA(A) with the selection criterion C;
22 a time coincidences unit that receives the output signal from the classifier
23 unit and, from outside the histogram calculation unit, individual binary enabling signals affecting
24 parameters other than DATA(A), wherein said time coincidences unit outputs a positive global
25 enabling signal when all the individual time coincidences signals are positive;
26 a test unit;
27 an analysis output unit including output memory;
28 an address multiplexer;

29 an incrementation enabling unit; and
30 a learning multiplexer;
31 wherein [[the]] a counter of each address in the memory corresponds to the value
32 d of [[a_{ij,t}]] a_{ijT} at a given instant, which is incremented by one unit when the time coincidences
33 unit outputs a positive global enabling signal;
34 wherein the test unit intended is provided for calculating and storing statistical
35 data processes, after receiving the data [[a_{ij,t}]] a_{ijT} corresponding to the space at an instant T,
36 [[the]] a content of the analysis memory in order to update the output memory of the analysis
37 output unit, wherein the output memory is deleted before [[the]] a beginning of each frame for a
38 space at an instant T by an initialization signal;
39 wherein the learning multiplexer is configured to receive an external command
40 signal and initiate an operation according to a learning mode in which registers of the classifier
41 unit and of the time coincidences unit are deleted when starting to process a frame, wherein the
42 analysis output register unit supplies values typical of [[the]] a sequence of each of these
43 registers.

1 4. (Currently Amended) A visual perception processor according to claim 3,
2 wherein the memory of the classifier is an addressable memory enabling real time updating of
3 the selection criterion C and having a data input register, an address command register and a
4 writing command register, receiving on its input register the output from the analysis memory
5 and a signal End on its writing command register, the processor further comprising a data input
6 multiplexer with two inputs and one output, receiving on one of its inputs a counting signal and
7 on its other input the succession of data [[a_{ij,t}]] a_{ijT} to the address command of the memory of the
8 classifier and an operator OR controlling the address multiplexer and receiving on its inputs an
9 initialization signal and the end signal END.

1 5. (Original) A visual perception processor according to claim 4, wherein
2 the space (i, j) is two-dimensional and wherein the signal DATA(A) is associated with the pixels
3 of a succession of images.

1 6. (Original) A visual perception processor according to claim 3, further
2 comprising means for anticipating the value of the classification criterion C.

1 7. (Original) A visual perception processor according to claim 6, wherein
2 the means for anticipating the value of the classification criterion C comprises memories
3 intended for containing the values of statistical parameters relating to two successive frames T_0
4 and T_1 .

1 8. (Currently Amended) A visual perception processor according to claim 7,
2 wherein the statistical parameters are the average values of the data $[[a_{ijt}]]$ a_{ijt} enabled.

1 9. (Currently Amended) A visual perception processor according to ~~claims~~
2 claim 3, wherein the analysis output register stores in its memory at least one of the following
3 values: the minimum 'MIN', the maximum 'MAX', the maximum number of pixels for which
4 the signal V_{ijt} has a particular value 'RMAX', the particular value corresponding POSRMAX,
5 and the total number of enables pixels 'NBPTS'.

1 10. (Original) A visual perception processor according to claim 3, wherein
2 the statistical comparison parameter used by the classifier is $RMAX/2$.

1 11. (Original) A visual perception processor according to claim 3, further
2 comprising a control multiplexer configured to receive at its input several statistical parameters
3 and wherein the comparison made by the classifier depends on a command issued by the control
4 multiplexer.

1 12. (Original) A visual perception processor according to claim 3, wherein
2 the memory of the classifier includes a set of independent registers D, each comprising one
3 input, one output and one writing command register, wherein the number of these registers D is
4 equal to the number n of bits of the numbers of the succession V_{ijt} , the classifier further
5 comprising a decoder configured to output a command signal corresponding to the related input

6 value (address) and a multiplexer controlled by this input value, thus enabling to read the chosen
7 register.

1 13. (Original) A visual perception processor according to claim 12, further
2 comprising register input multiplexers, each being associated with the input of a register, and
3 combinatory modules connecting the registers to one another, wherein the register input
4 multiplexers are configured to choose between a sequential writing mode and a writing mode
5 common to all the registers connected together by the combinatory modules.

1 14. (Original) A visual perception processor according to claim 13, wherein
2 the combinatory modules comprise a morphological expansion operator including a three-input
3 logic unit 'OR', wherein the first input unit receives the output signal of the 'Q'-order register,
4 wherein the second input unit is connected to the output of a two-input logic unit 'AND'
5 receiving respectively the output signal of the 'Q+1'-order register and a positive expansion
6 signal, and wherein the third input unit is connected to the output of a two-input logic unit
7 'AND' receiving respectively the output signal of the 'Q-1'-order register and a negative
8 expansion signal.

1 15. (Original) A visual perception processor according to claim 14, wherein
2 the combinatory modules comprise a morphological erosion operator including a three-input
3 logic unit 'AND', wherein the first input unit receives the output signal of the 'Q'-order register,
4 wherein the second input unit is connected to the output of a logic unit 'AND', wherein one four-
5 input reverse receives respectively the output signal of the 'Q'-order register, the output signal of
6 the 'Q-1'-order register, the output signal of the 'Q+1'-order register and a negative erosion
7 signal, and wherein the third input unit is connected to the output of a four-input logic unit
8 'AND', wherein one reverse receives respectively the output signal of the 'Q'-order register, the
9 output signal of the 'Q-1'-order register, the output signal of the 'Q+1'-order register and a
10 negative erosion signal.

1 16. (Original) A histogram calculation unit according to claim 14, wherein
2 each combinatory module comprises a multiplexer associating a morphological expansion
3 operator and a morphological erosion operator.

1 17. (Original) A device for detecting one or more events including aural
2 and/or visual phenomena, the device comprising:

3 a controller coupled to a controller bus and a transfer bus;

4 an input portal adapted to receive data describing one or more parameters of the
5 event being detected; and

6 a data processing block coupled to the input portal, the transfer bus and the
7 controller bus, the data processing block including:

8 a histogram unit coupled to the input portal and configured to calculate a
9 histogram for a selected parameter;

10 a classification unit coupled to the input portal and the histogram unit, and
11 configured to determine the data in the histogram that satisfy a selected criterion, and to generate
12 an output accordingly, the classification unit supplying the output to the transfer bus; and

13 a coincidence unit coupled to receive the output of the classification unit from the
14 transfer bus and to receive selected coincidence criteria from the controller bus, the coincidence
15 unit being configured to generate an enable signal for the histogram unit when the output of the
16 classification unit satisfies the selected coincidence criterion,

17 wherein classification is performed automatically by processing statistical
18 information associated with the calculated histogram.

1 18. (Original) The device of claim 17, wherein the classification unit includes
2 a memory table for storing selection criteria, and wherein automatic classification involves
3 updating the selection criteria in the memory table based on the processed statistical information.

1 19. (Original) The device of claim 18, wherein the processed statistical
2 information includes a value RMAX defining the number of data points at the maximum of the

3 calculated histogram, and wherein automatic classification involves updating the selection
4 criteria in the memory table based on the value RMAX.

1 20. (Original) The device of claim 17, wherein the classification unit includes
2 a memory table for storing selection criteria, and wherein automatic classification involves
3 changing an address input to the memory table based on the processed statistical information.

1 21. (Original) A device for detecting one or more events including aural
2 and/or visual phenomena, the device comprising:
3 a controller coupled to a controller bus and a transfer bus;
4 an input multiplexer adapted to receive data describing one or more parameters of
5 the event being detected, and to output data describing a selected one of the one or more
6 parameters in response to a selection signal; and
7 a data processing block coupled to the multiplexer, the transfer bus and the
8 controller bus, the data processing block including:
9 a histogram unit coupled to the input portal and configured to calculate a
10 histogram for the selected parameter;
11 a classification unit coupled to the input portal and the histogram unit, and
12 configured to determine the data in the histogram that satisfy a selected criterion, and to generate
13 an output accordingly, the classification unit supplying the output to the transfer bus; and
14 a coincidence unit coupled to receive the output of the classification unit from the
15 transfer bus and to receive selected coincidence criteria from the controller bus, the coincidence
16 unit being configured to generate an enable signal for the histogram unit when the output of the
17 classification unit satisfies the selected coincidence criterion.

1 22. (Original) A device for detecting one or more events including aural
2 and/or visual phenomena, the device comprising:
3 a controller coupled to a controller bus and a transfer bus;
4 an input portal adapted to receive data sets describing one or more parameters of
5 the event being detected, each data set being associated with an instant of time; and

6 a data processing block coupled to the input portal, the transfer bus and the
7 controller bus, the data processing block including:
8 a histogram unit coupled to the input portal and configured to calculate a
9 histogram for a selected parameter for a particular instant of time T1;
10 a classification unit coupled to the input portal and the histogram unit, and
11 configured to determine the data in the histogram that satisfy a selected criterion, and to generate
12 an output accordingly, the classification unit supplying the output to the transfer bus; and
13 a coincidence unit coupled to receive the output of the classification unit from the
14 transfer bus and to receive selected coincidence criteria from the controller bus, the coincidence
15 unit being configured to generate an enable signal for the histogram unit when the output of the
16 classification unit satisfies the selected coincidence criterion,
17 wherein the classification unit automatically anticipates values associated with the
18 selected parameter at a next instant of time T2 based on statistical information associated with
19 the calculated histograms at time T1 and at a previous time T0.

1 23. (Original) The device of claim 22, wherein the statistical information at
2 each time T0 and T1 includes a value POSMOY defined as the value, for a set of parameters,
3 which is greater than or equal to half of the values of the set of parameters.

1 24. (Original) The device of claim 23, wherein automatic anticipation is
2 based on a function of POSMOY at T0 minus POSMOY at T1 (P0-P1).

1 25. (Original) The device of claim 24, wherein the function includes one of
2 $Y=(P0-P1)$, $Y=a(P0-P1)+b$, and $Y=a(P0-P1)^2$, where a and b are predetermined constants.

1 26. (Original) The device of claim 25, wherein two or more of the functions
2 are multiplexed.

1 27. (Original) A method of analyzing parameters associated with an event by
2 an electronic device, comprising:

- 3 a) receiving data sets representative of one or more parameters of the event being
4 detected, each data set being associated with an instant of time;
- 5 b) calculating, for each instant of time, a statistical distribution, defined as a
6 histogram, of a selected parameter of the event being detected;
- 7 c) classifying the data set by comparing its parameter values to classification
8 criteria stored in a classification memory;
- 9 d) enabling the calculating step when classified data satisfies predetermined time
10 coincidence criteria; and
- 11 e) anticipating values associated with the selected parameter for a next instant of
12 time T2 based on statistical information associated with the calculated histograms at an instant of
13 time T1 and at a previous instant of time T0.

1 28. (Original) A method of analyzing parameters associated with an event by
2 an electronic device, comprising:

- 3 a) receiving data representative of one or more parameters of the event being
4 detected;
- 5 b) calculating, for a given instant of time, a statistical distribution, defined as a
6 histogram, of a selected parameter of the event being detected;
- 7 c) classifying the data by comparing its value to classification criteria stored in a
8 classification memory;
- 9 d) enabling the calculating step when classified data satisfies predetermined time
10 coincidence criteria; and
- 11 e) automatically updating, for each instant of time, the classification criteria
12 stored in the classification memory based on statistical information associated with the
13 histogram.

1 29. A visual perception processor according to claim 3, wherein the histogram
2 calculation units are organized into a matrix

REMARKS/ARGUMENTS

Claims 1-28 were pending. Claims 1-4, 8 and 9 have been amended, and new claim 29 has been added. Therefore, upon entry of this amendment, which is respectfully requested, claims 1-29 will be pending.

The drawings were objected to for various reasons. For Figures 6-11 and 21 it was stated that arrow heads at the input and output of devices, and the word "NO", were missing from connections. Additionally, it was stated that Figures 13, 15 and 31 should be renumbered as indicated. Appropriate correction has been made in the form of proposed amendments to the drawings. A red-lined version is included to show proposed changes. Additionally, correction to the specification to keep Figure numbers in conformity with the drawing changes has been made.

Claims 3-16 were objected to because it was believed that claim 3 at line 29 required a "wherein" before "the". Appropriate correction has been made.

Claims 3-16 were rejected under 35 USC §112, second paragraph, as being indefinite as many limitations were alleged to lack antecedent basis. Appropriate correction has been made by amendments to claim 3. Additionally, amendments were made to claims 3, 4 and 8 to correct for minor typographical errors.

Applicant thanks the examiner for the allowance of claims 17-28.

Claims 3-16 were indicated as being allowable if rewritten or amended to overcome the rejection under 35 USC §112, second paragraph. Responsive to this indication, appropriate correction has been made by way of amendments to claim 3. Additionally, claim 3 has been rewritten in independent form. Accordingly, it is respectfully asserted that these claims are in condition for allowance.

Claims 1 and 2 were rejected under 35 USC §102(b) as being anticipated by Ric Ka et al., U.S. patent No. 5,359,533 ("Ric Ka").

Applicant respectfully asserts that Ric Ka fails to teach or suggest the limitations as presently recited in claims 1 and 2. For example, Ric Ka fails to teach or suggest two or more histogram calculation units wherein the histogram calculation units are configured to form a histogram representative of the parameter as a function of a validation signal and to determine a

Appl. No. 09/792,436
Amdt. dated August 26, 2004
Reply to Office Action of March 26, 2004

PATENT

binary classification signal resulting from a comparison of the parameter and a selection criterion C, wherein the classification signal is sent to a time coincidences bus, and wherein the validation signal is produced from time coincidences signals such that the calculation of the histogram depends on the classification signals carried by the time coincidences bus, as is recited in claim 1. The "start" and "hit" signals of Ric Ka do not suggest the digital signal a_{jT} of the present invention. Also, there is no time coincidences bus between multiple units and the MTIA of Ric Ka cannot interact with another MTIA through such a time coincidences bus. Moreover, there is no teaching or motivation in Ric Ka to create a system in which the computation of a histogram in a histogram calculation unit may depend on the computations in other such units. Advantageously, in the present invention, the use of a time coincidences bus, which is shared between the histogram calculation units, allows for a time dependent amplification effect. Accordingly, it is respectfully asserted that Ric Ka, as well as the other cited references, fail to teach or suggest limitations of claim 1, and that this claim and dependent claim 2 are therefore novel and non-obvious.

CONCLUSION

In view of the foregoing, Applicants believe all claims now pending in this Application are in condition for allowance. The issuance of a formal Notice of Allowance at an early date is respectfully requested.

If the Examiner believes a telephone conference would expedite prosecution of this application, please telephone the undersigned at 925-472-5000.

Respectfully submitted,

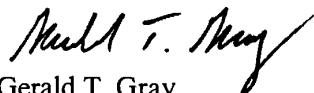
Gerald T. Gray
Reg. No. 41,797

TOWNSEND and TOWNSEND and CREW LLP
Two Embarcadero Center, Eighth Floor
San Francisco, California 94111-3834
Tel: 925-472-5000
Fax: 415-576-0300
Attachments
GTG:sea
60190347 v1

Appl. No. 09/792,436
Amdt. dated August 26, 2004
Reply to Office Action of March 26, 2004

PATENT

Amendments to the Drawings:

The attached sheets of drawings includes changes to Figs. 6-11,13, 13a, 13b, 13c, 15, 15a, 21, 31 and 31a. These sheets, which include Figs. 5-13, 13a, 13b, 13c, 15, 15a, 21, 30, 31 and 31a replace the original sheets including Figs. 5-13, 13a, 13b, 13c, 15, 15a, 21, 30, 31 and 31a.

Attachment: Replacement Sheets
Annotated Sheets Showing Changes

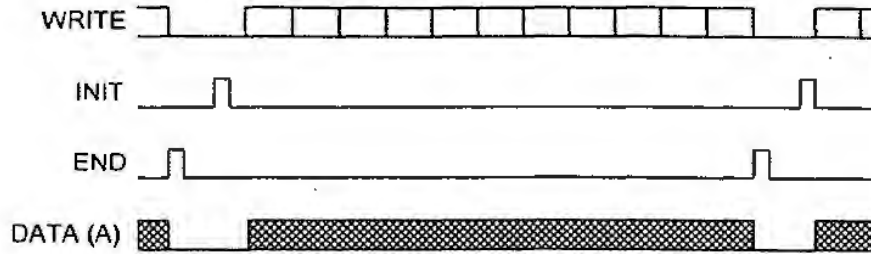

FIG. 5

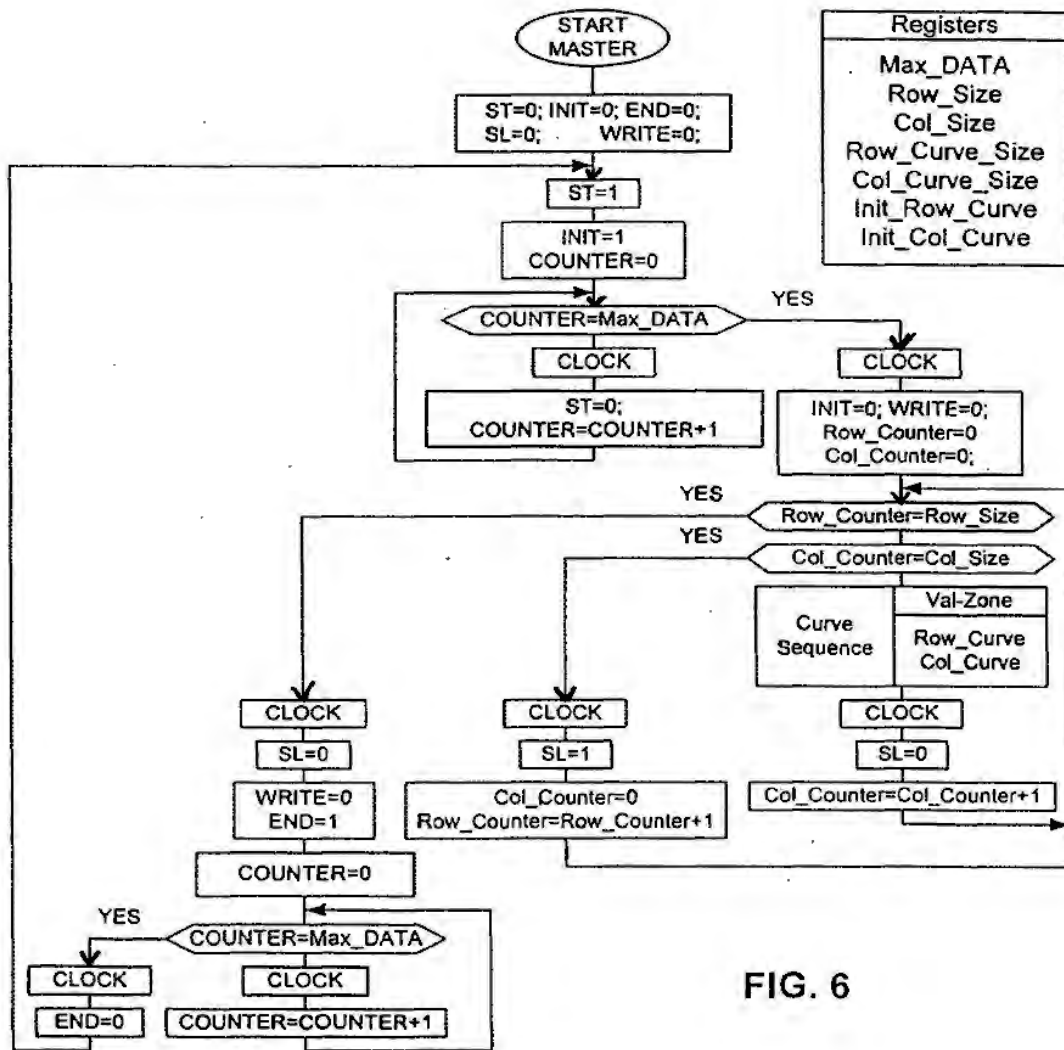

FIG. 6



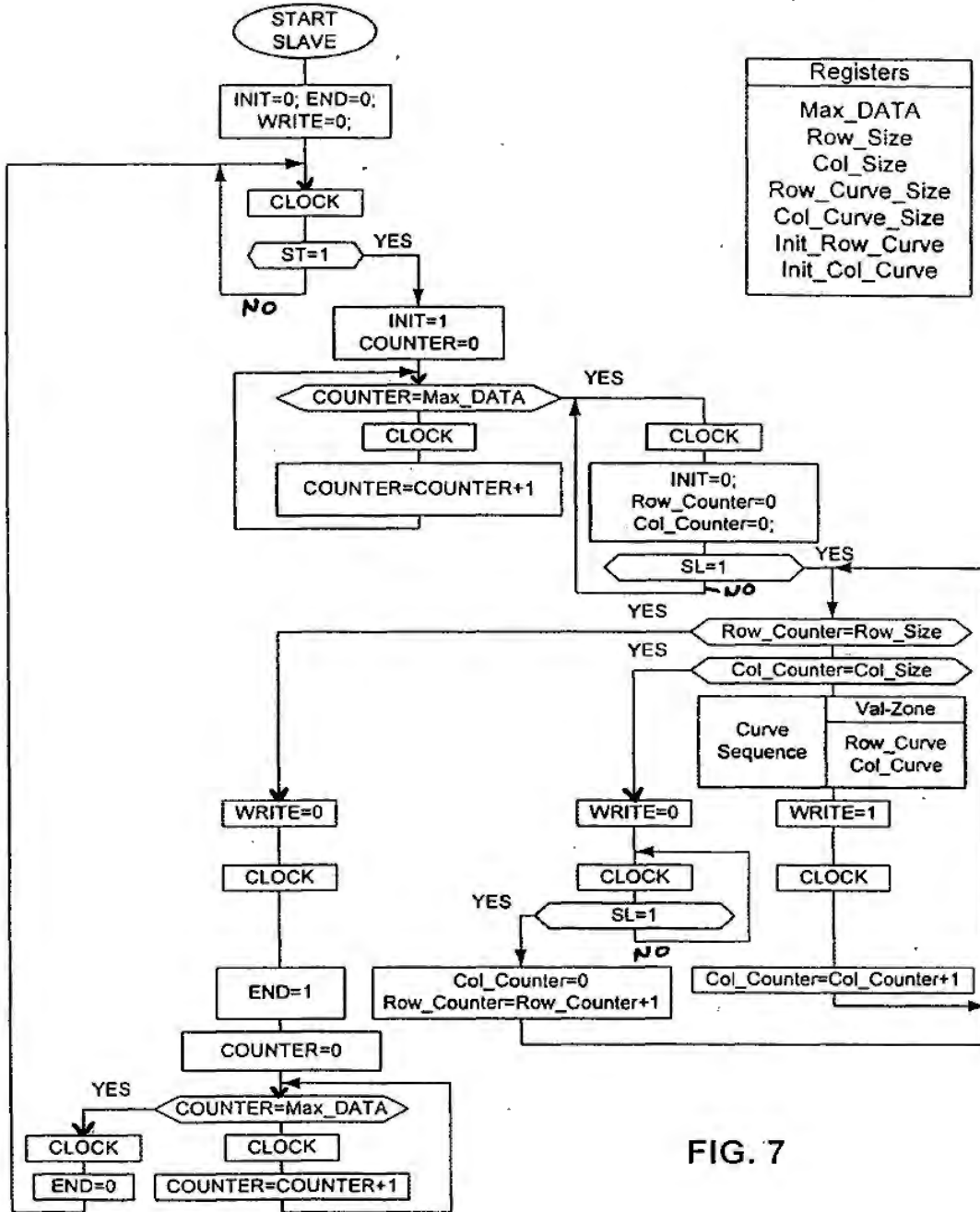

FIG. 7





7/31

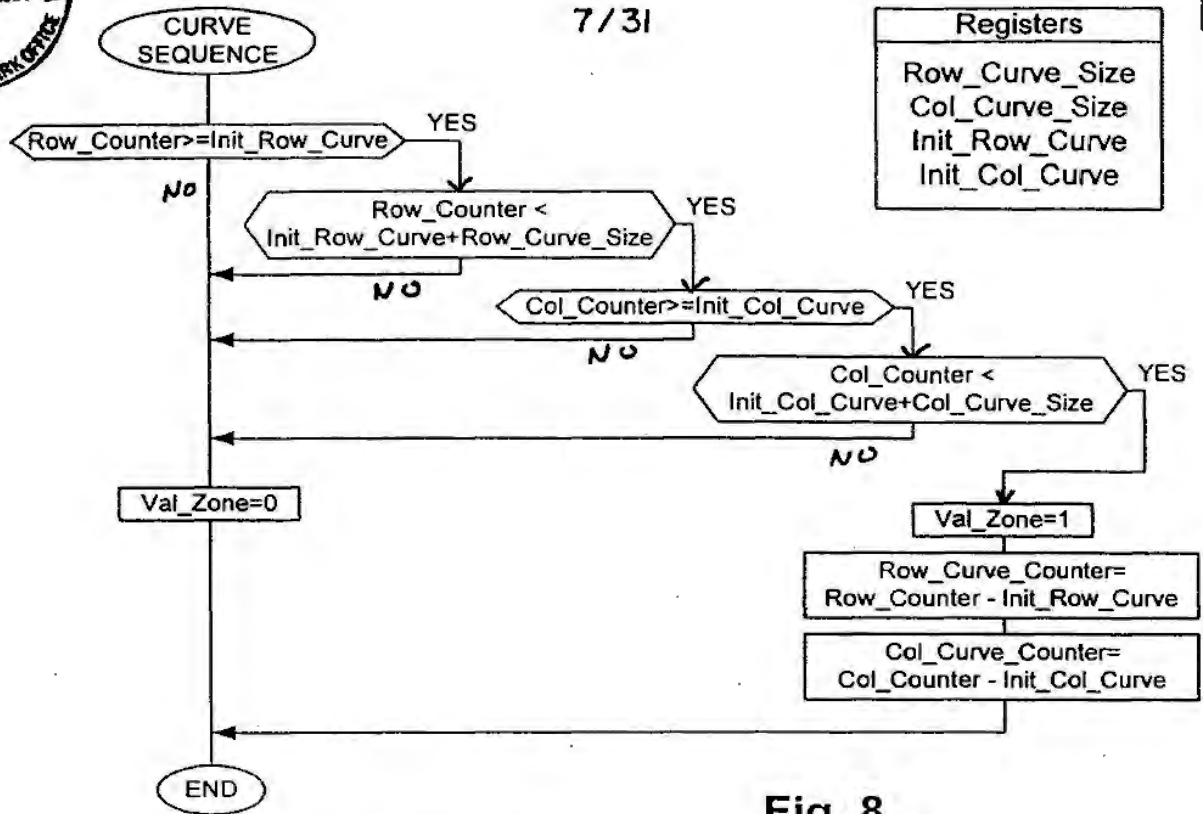

Fig. 8

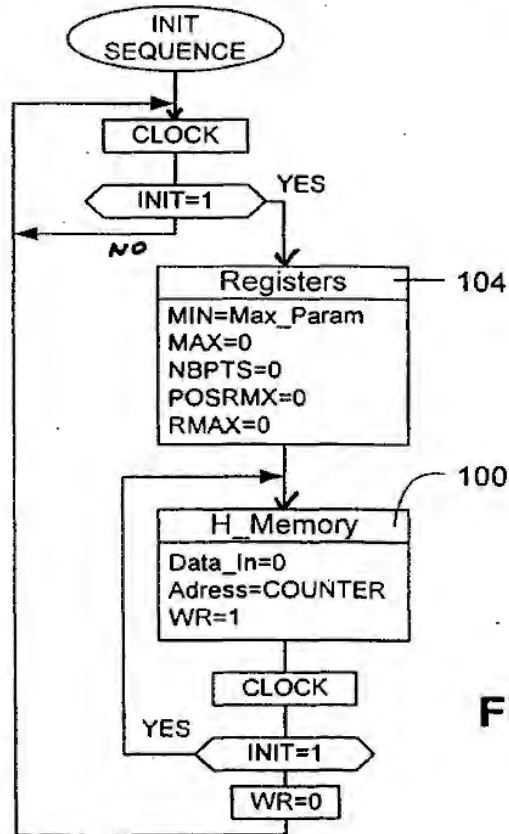

Fig. 9



8/31

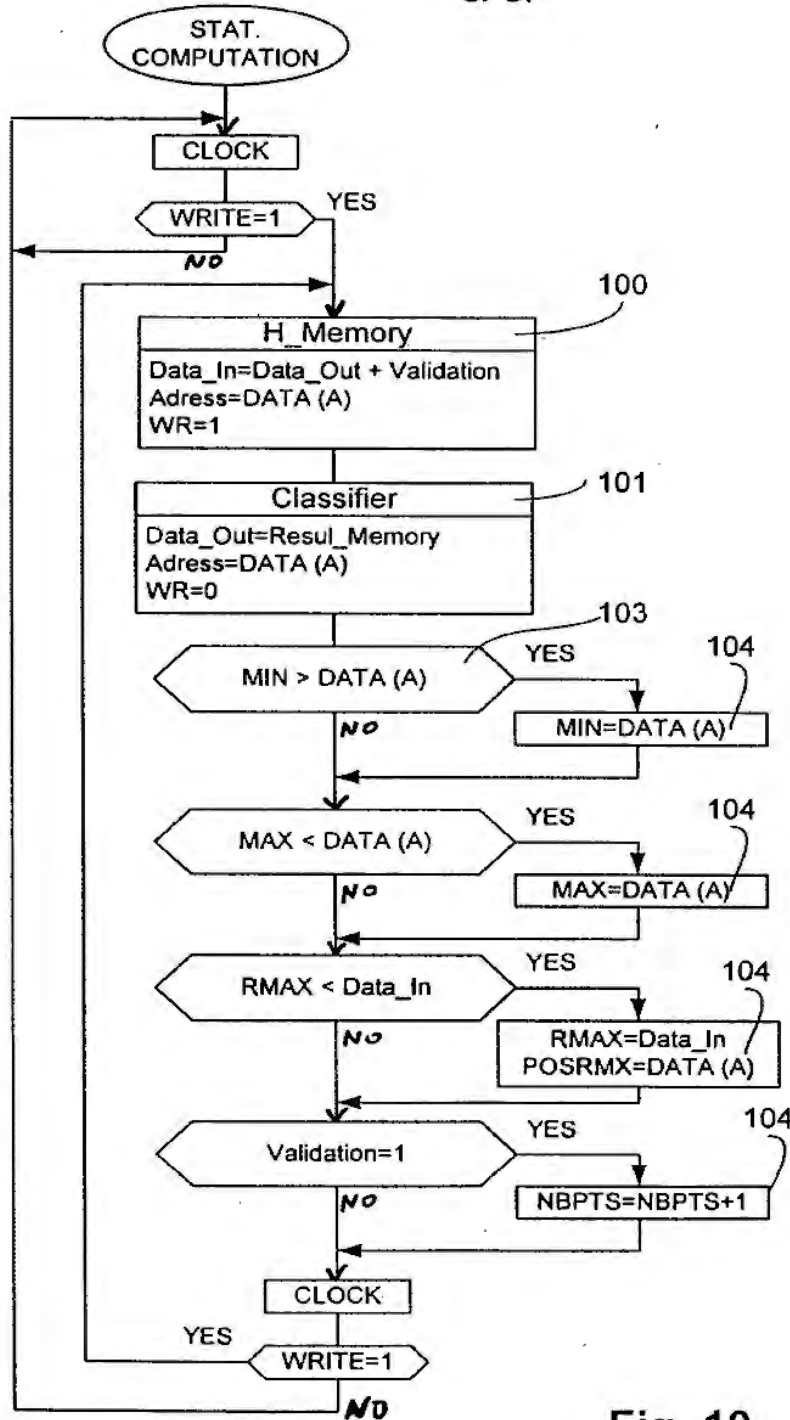

Fig. 10





9/31

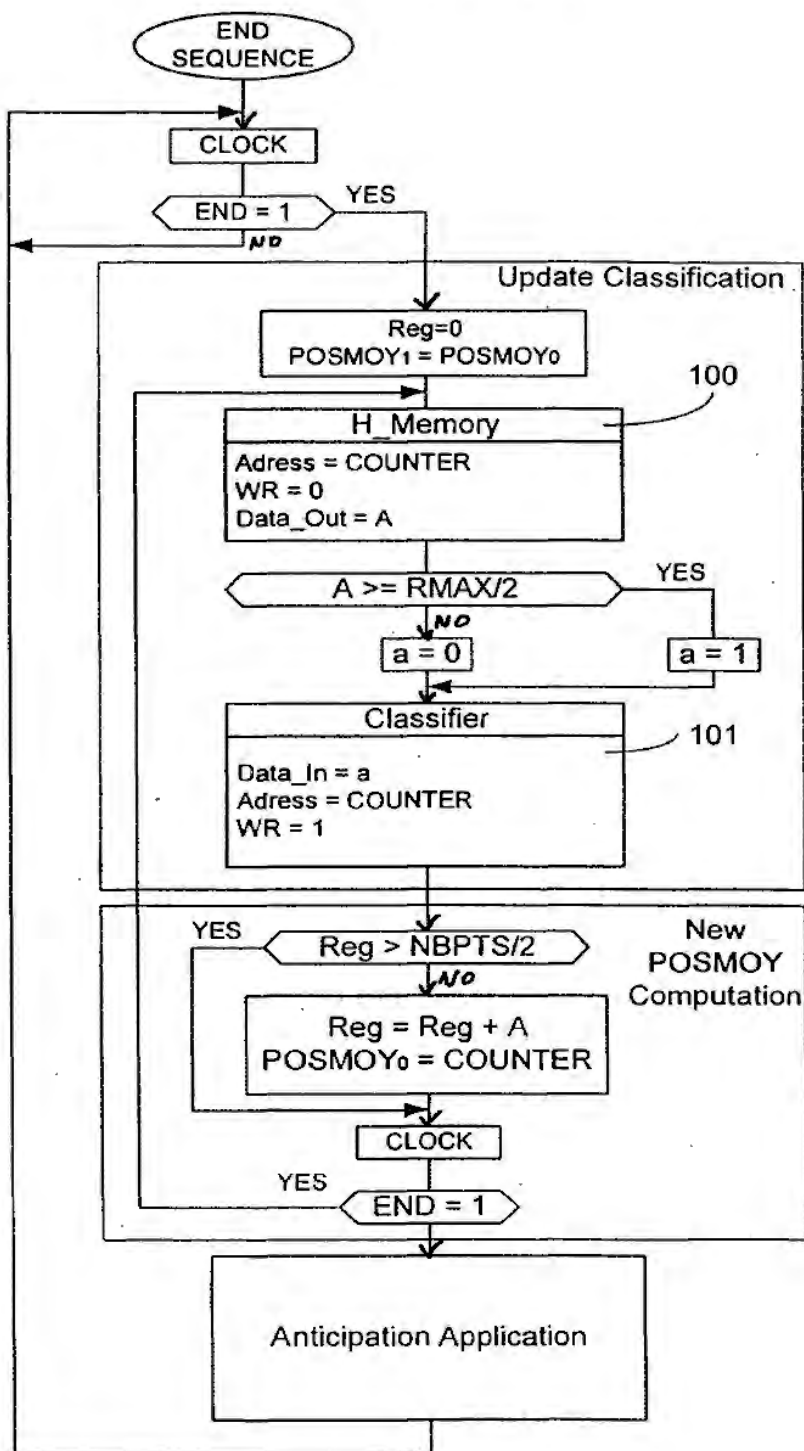

Fig. 11



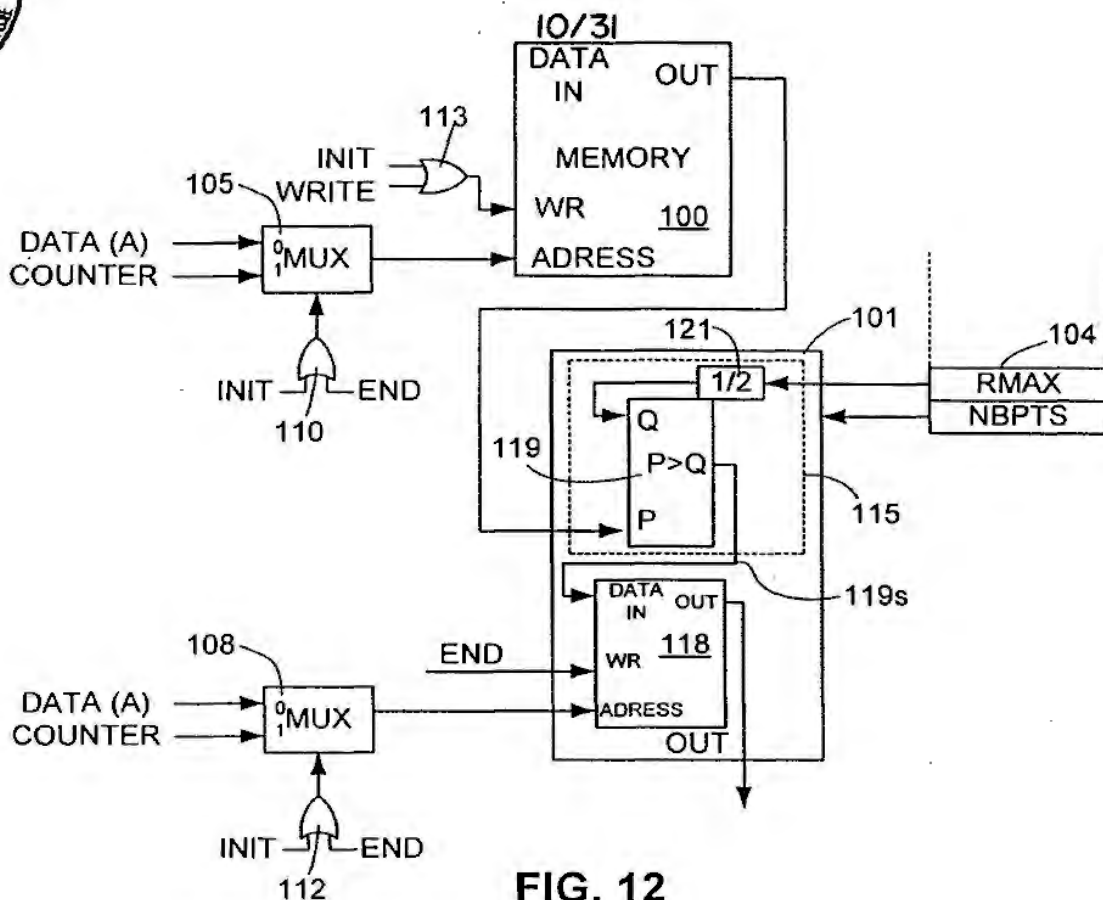

FIG. 12

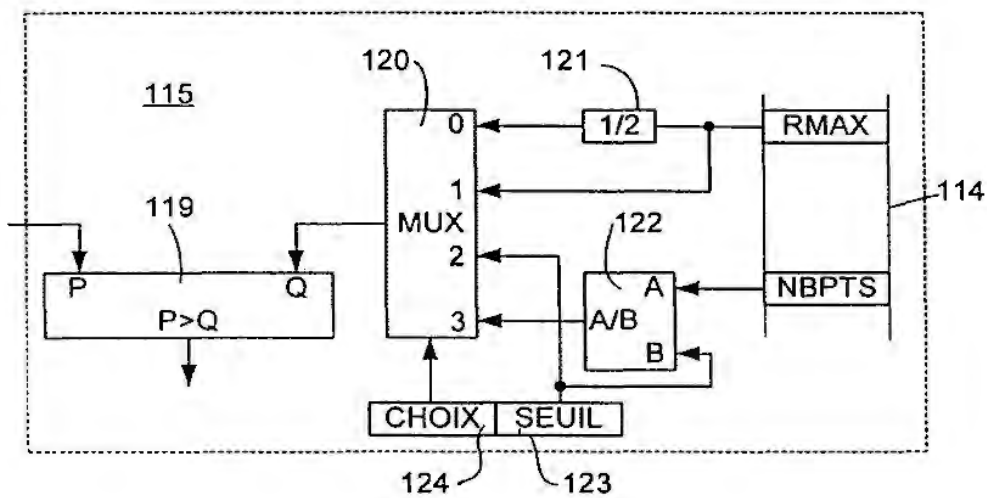

FIG. 13a



11/31

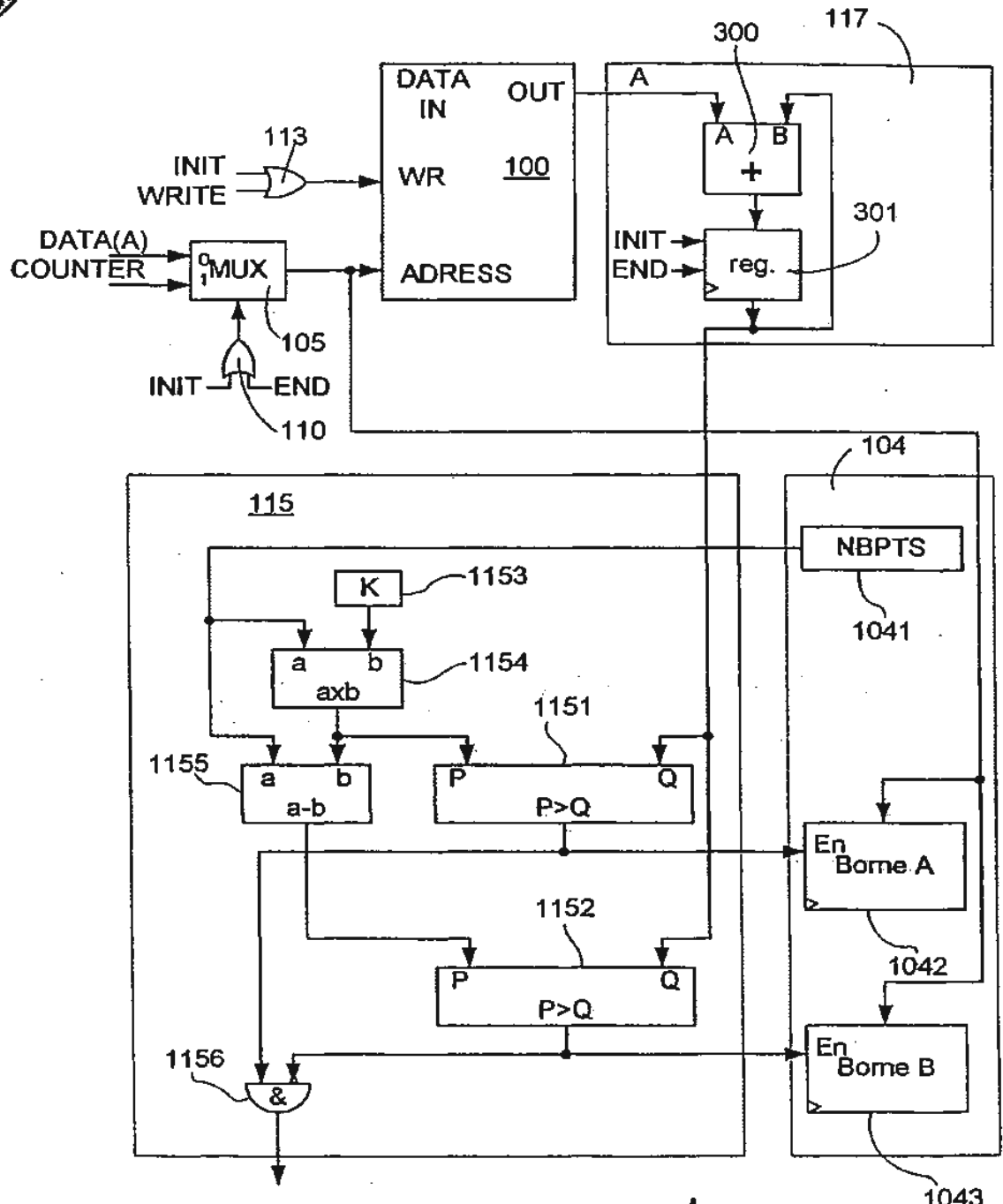

FIG. 13d



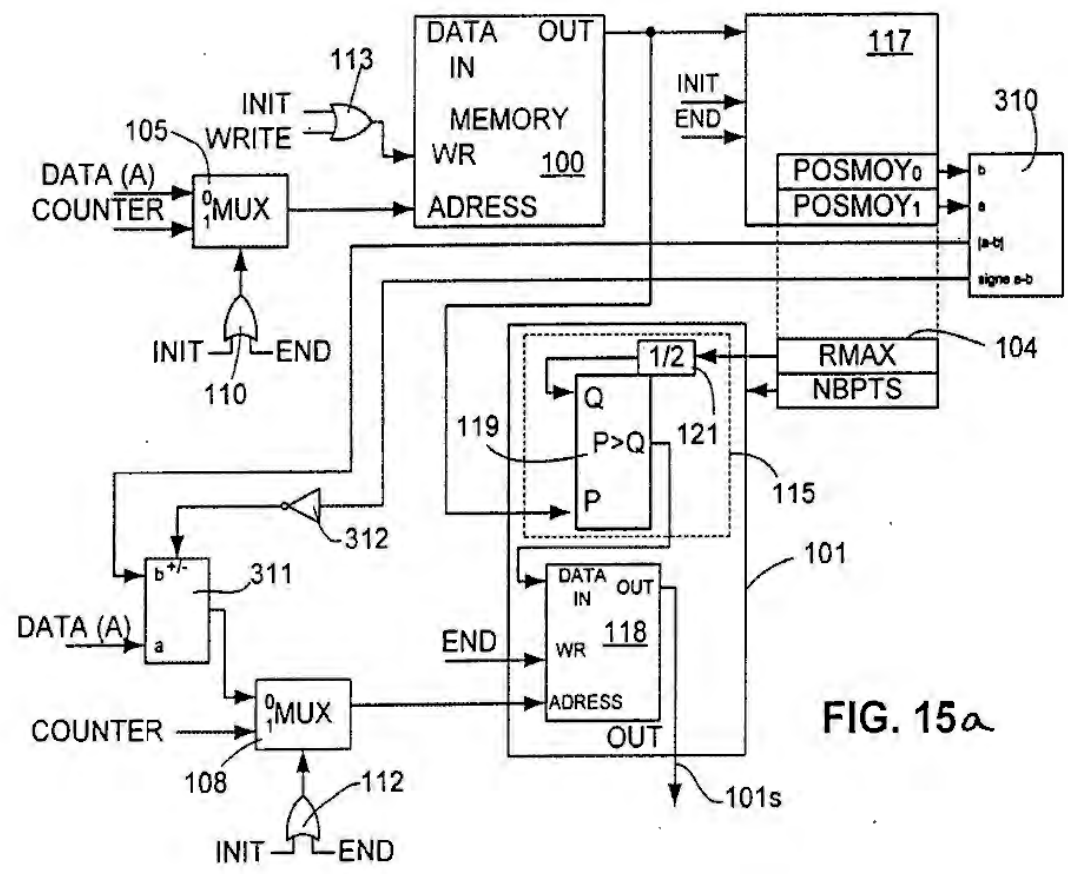
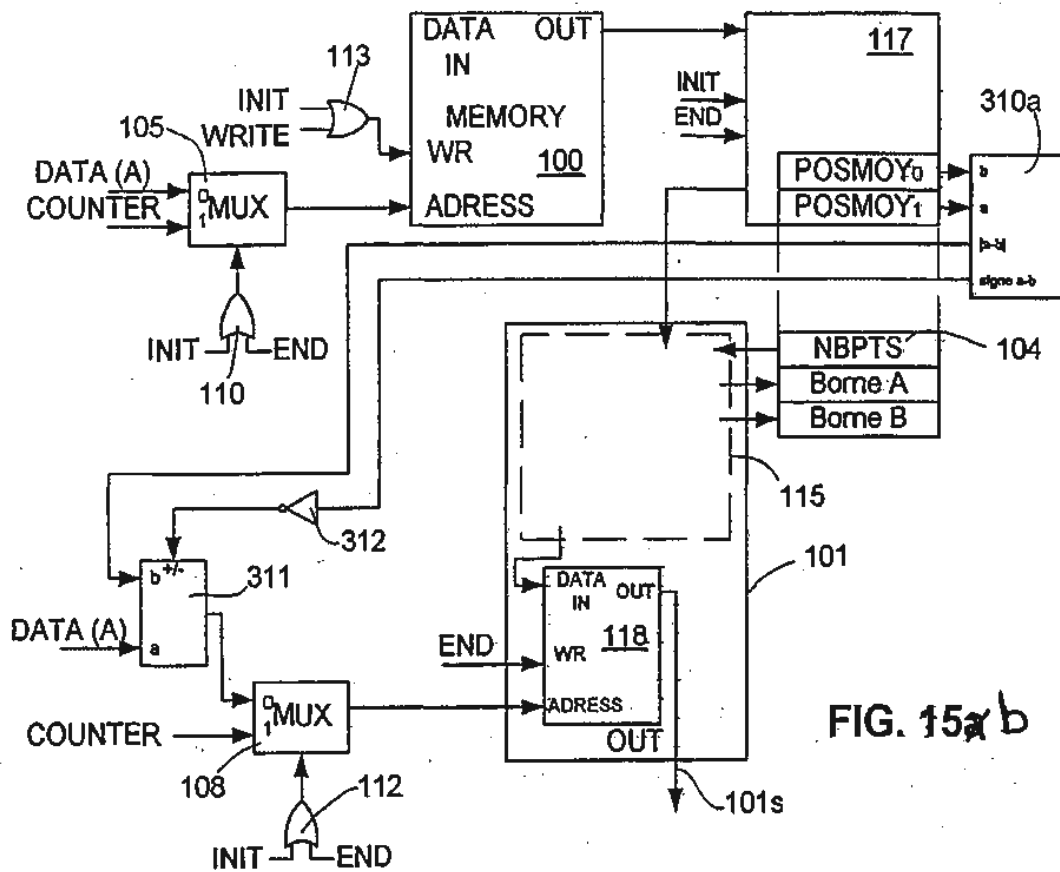

FIG. 15a

13/31



14/31

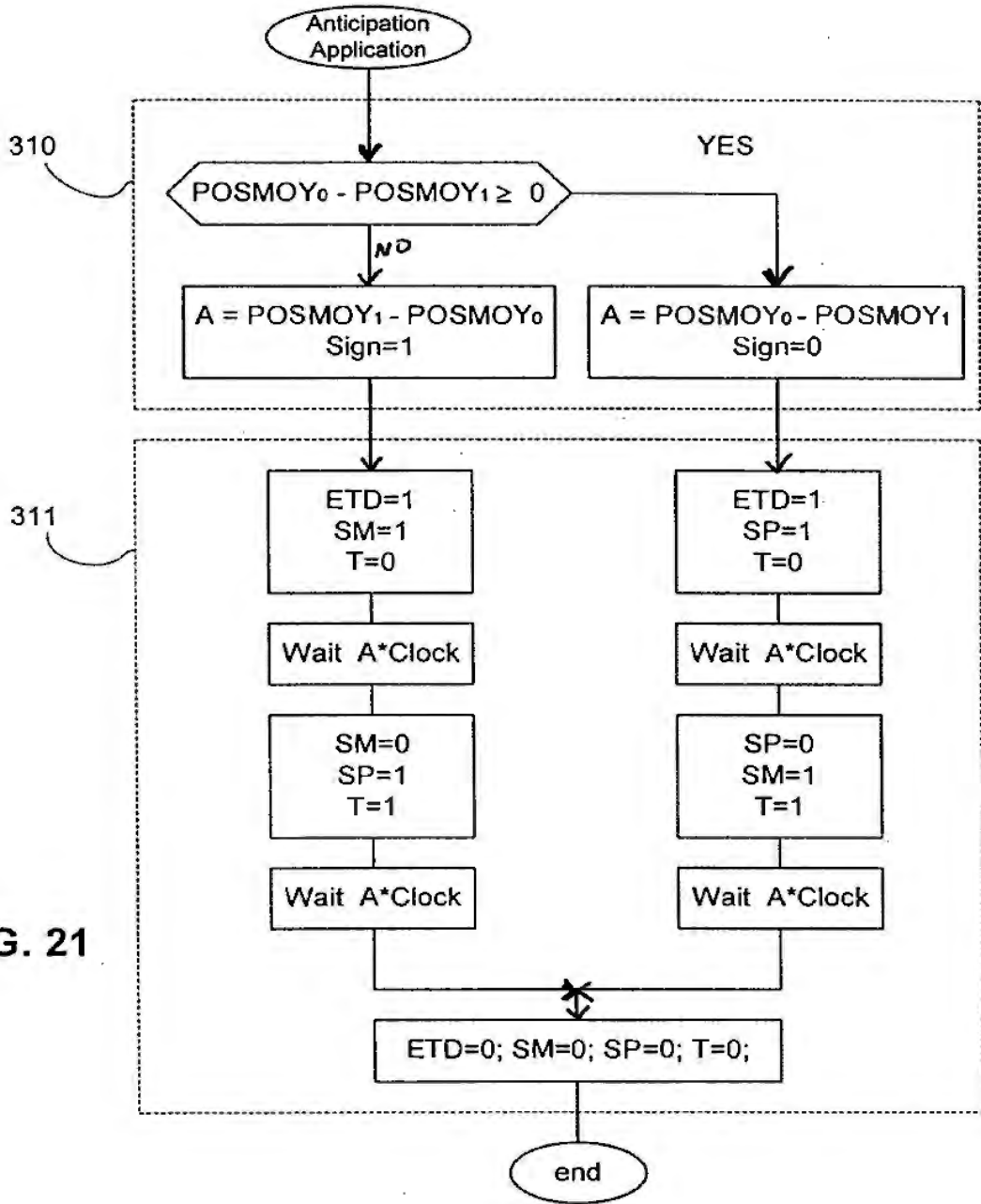

FIG. 21



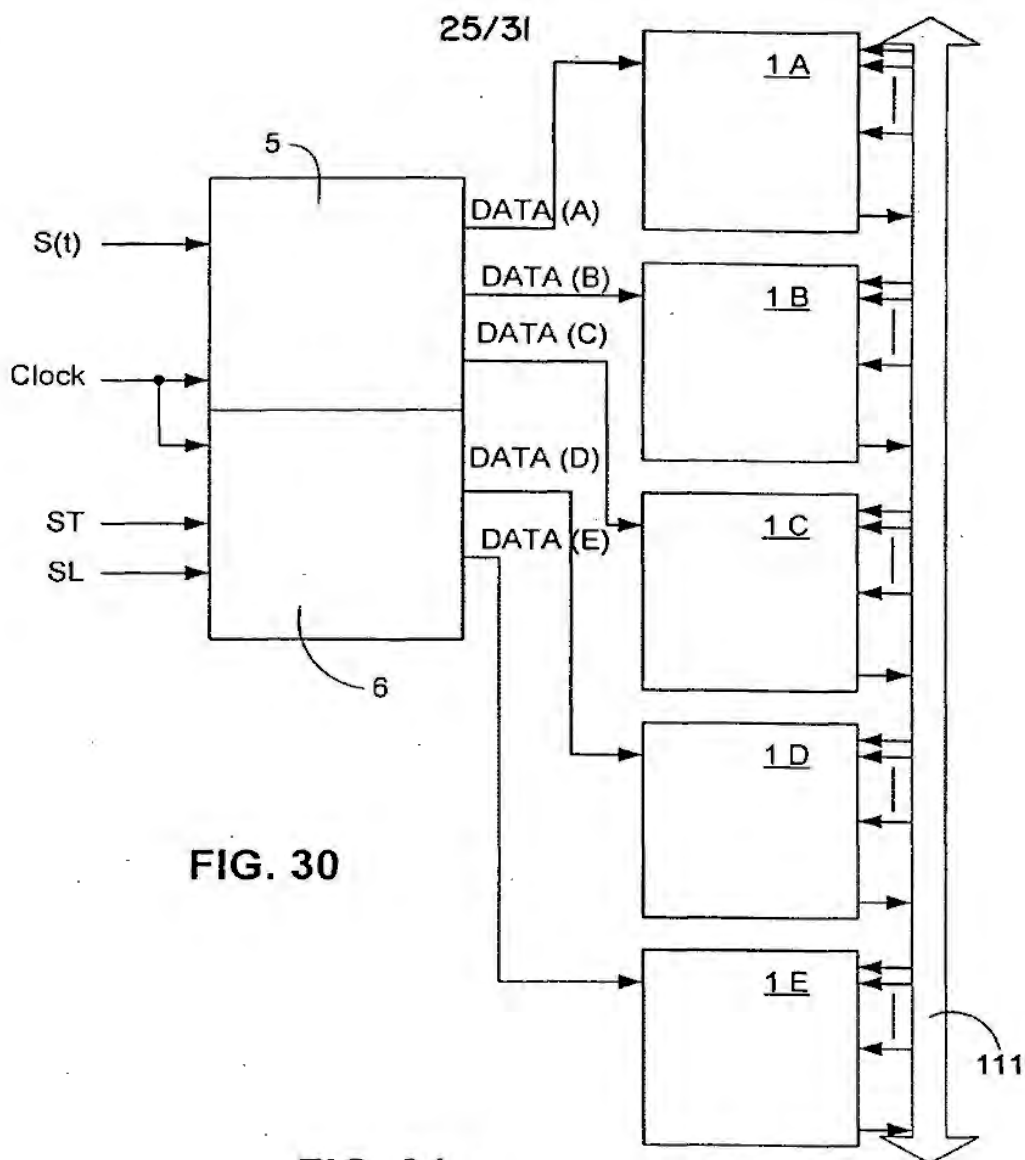
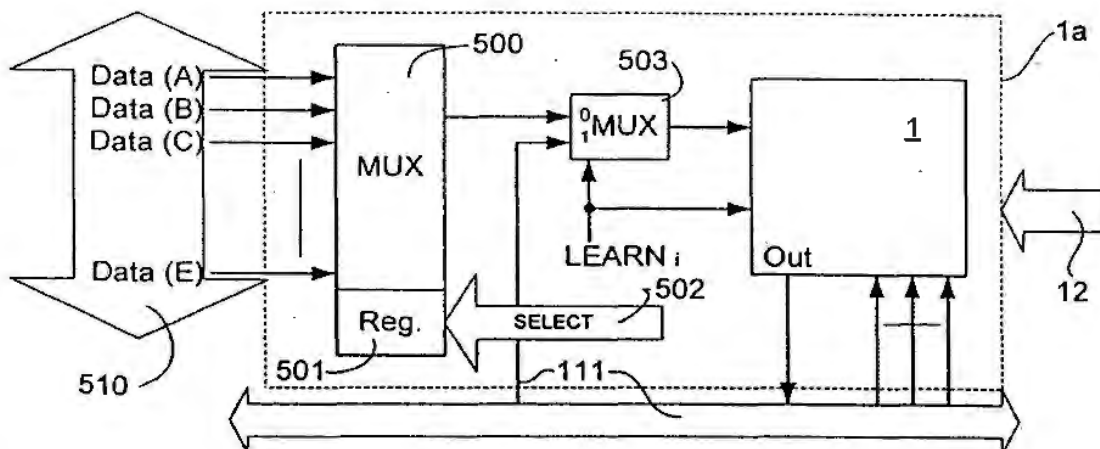

FIG. 30

FIG. 31a





26/31

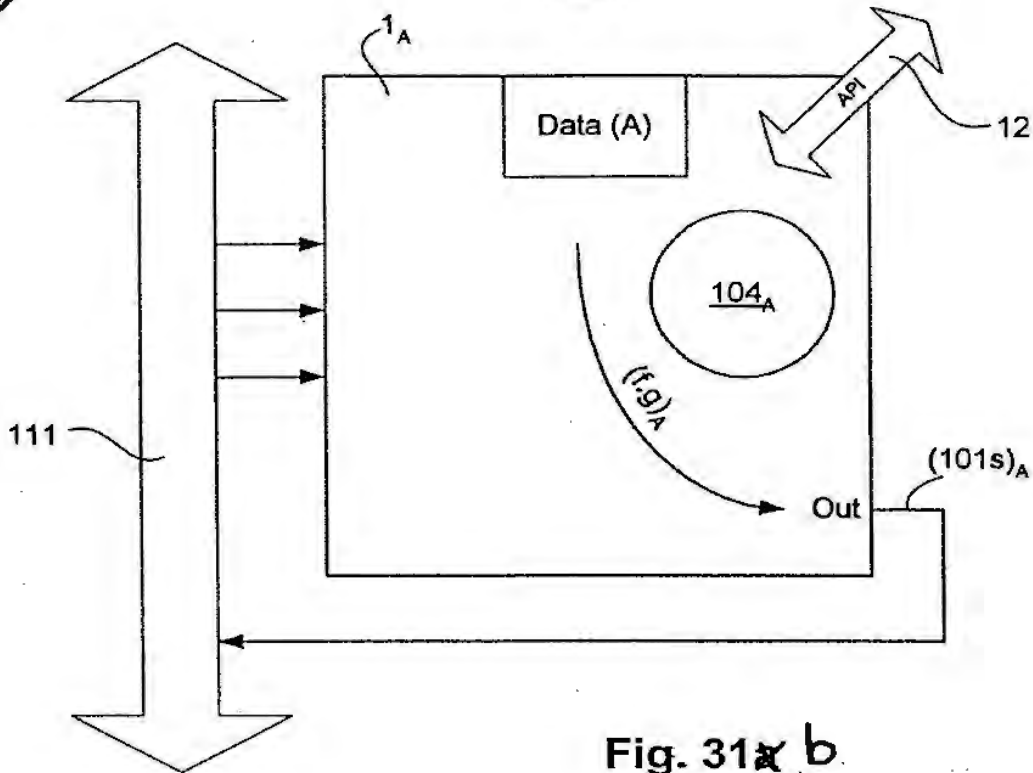

Fig. 31a b

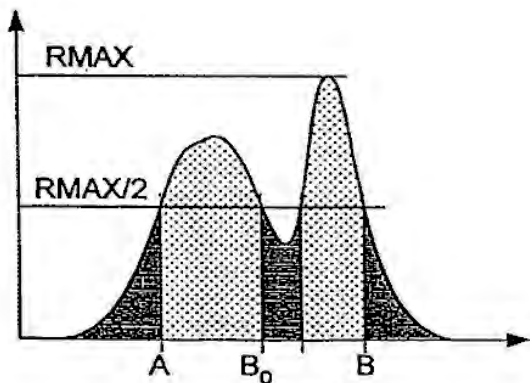

Fig 13a b

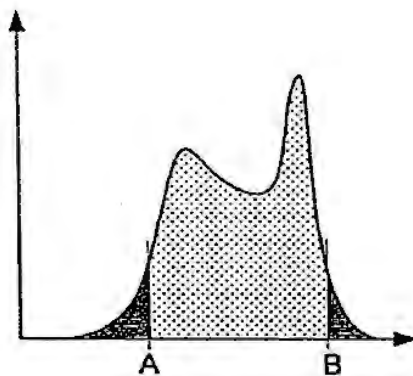

Fig 13a c





PETITION FOR EXTENSION OF TIME UNDER 37 CFR 1.136(a)	Docket Number (Optional) 20046H-000100US
---	---

In re Application of Patrick Pirim	
Application Number 09/792,436	Filed February 23, 2001
For METHOD AND DEVICE FOR AUTOMATIC VISUAL PERCEPTION	
Art Unit 2121	Examiner George B. Davis

This is a request under the provisions of 37 CFR 1.136(a) to extend the period for filing a reply in the above identified application.

The requested extension and appropriate non-small-entity fee are as follows (check time period desired):

- One month (37 CFR 1.17(a)(1)) \$
- Two months (37 CFR 1.17(a)(2)) \$420
- Three months (37 CFR 1.17(a)(3)) \$
- Four months (37 CFR 1.17(a)(4)) \$
- Five months (37 CFR 1.17(a)(5)) \$
- Applicant claims small entity status. See 37 CFR 1.27. Therefore, the fee amount shown above is reduced by one-half, and the resulting fee is: \$.
- A check in the amount of the fee is enclosed.
- Payment by credit card. Form PTO-2038 is attached.
- The Director has already been authorized to charge fees in this application to a Deposit Account.
- The Director is hereby authorized to charge any fees which may be required, or credit any overpayment, to Deposit Account Number 20-1430.

I have enclosed a duplicate copy of this sheet.

- I am the applicant/inventor.
- assignee of record of the entire interest. See 37 CFR 3.71
Statement under 37 CFR 3.73(b) is enclosed. (Form PTO/SB/96).
- attorney or agent of record.. Registration Number 41,797
- attorney or agent under 37 CFR 1.34(a).
Registration number if acting under 37 CFR 1.34(a) _____.

WARNING: Information on this form may become public. Credit card information should not be included on this form. Provide credit card information and authorization on PTO-2038.

August 26, 2004
Date

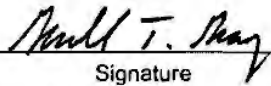
Signature
Gerald T. Gray, Reg. No. 41,797
Typed or printed name

NOTE: Signatures of all the inventors or assignees of record of the entire interest or their representative(s) are required. Submit multiple forms if more than one signature is required, see below*.

*Total of _____ forms are submitted.

60293767 v1

08/31/2004 WASFAM1 00000044 201430 09792436

01 FC:1252 420.00 DA

PATENT APPLICATION FEE DETERMINATION RECORD
Effective October 1, 2000

Application or Docket Number

09/792436

CLAIMS AS FILED - PART I

	(Column 1)	(Column 2)
TOTAL CLAIMS		
FOR	NUMBER FILED	NUMBER EXTRA
TOTAL CHARGEABLE CLAIMS	28 minus 20 =	
INDEPENDENT CLAIMS	6 minus 3 =	
MULTIPLE DEPENDENT CLAIM PRESENT		<input type="checkbox"/>

* If the difference in column 1 is less than zero, enter "0" in column 2

SMALL ENTITY TYPE OR OTHER THAN SMALL ENTITY

RATE	FEE	OR	RATE	FEE
BASIC FEE	355.00	OR	BASIC FEE	710.00
X\$ 9=		OR	X\$18=	
X40=		OR	X80=	
+135=		OR	+270=	
TOTAL		OR	TOTAL	

CLAIMS AS AMENDED - PART II

	(Column 1)	(Column 2)	(Column 3)
AMENDMENT A	CLAIMS REMAINING AFTER AMENDMENT	HIGHEST NUMBER PREVIOUSLY PAID FOR	PRESENT EXTRA
Total	27	28	
Independent	7	6	
FIRST PRESENTATION OF MULTIPLE DEPENDENT CLAIM			<input type="checkbox"/>

SMALL ENTITY OR OTHER THAN SMALL ENTITY

RATE	ADDITIONAL FEE	OR	RATE	ADDITIONAL FEE
X\$ 9=		OR	X\$18=	
X40=		OR	X80=	
+135=		OR	+270=	
TOTAL ADDIT. FEE		OR	TOTAL ADDIT. FEE	

	(Column 1)	(Column 2)	(Column 3)
AMENDMENT B	CLAIMS REMAINING AFTER AMENDMENT	HIGHEST NUMBER PREVIOUSLY PAID FOR	PRESENT EXTRA
Total			
Independent			
FIRST PRESENTATION OF MULTIPLE DEPENDENT CLAIM			<input type="checkbox"/>

RATE	ADDITIONAL FEE	OR	RATE	ADDITIONAL FEE
X\$ 9=		OR	X\$18=	
X40=		OR	X80=	
+135=		OR	+270=	
TOTAL ADDIT. FEE		OR	TOTAL ADDIT. FEE	

	(Column 1)	(Column 2)	(Column 3)
AMENDMENT C	CLAIMS REMAINING AFTER AMENDMENT	HIGHEST NUMBER PREVIOUSLY PAID FOR	PRESENT EXTRA
Total			
Independent			
FIRST PRESENTATION OF MULTIPLE DEPENDENT CLAIM			<input type="checkbox"/>

RATE	ADDITIONAL FEE	OR	RATE	ADDITIONAL FEE
X\$ 9=		OR	X\$18=	
X40=		OR	X80=	
+135=		OR	+270=	
TOTAL ADDIT. FEE		OR	TOTAL ADDIT. FEE	

If the entry in column 1 is less than the entry in column 2, write "0" in column 3.
 ** If the "Highest Number Previously Paid For" IN THIS SPACE is less than 20, enter "20."
 *** If the "Highest Number Previously Paid For" IN THIS SPACE is less than 3, enter "3."
 The "Highest Number Previously Paid For" (Total or independent) is the highest number found in the appropriate box in column 1.

Best Available Copy



2121
41

PTO/SB/21 (02-04)

TRANSMITTAL FORM <small>(to be used for all correspondence after initial filing)</small>	Application Number	09/792,436	
	Filing Date	February 23, 2001	
	First Named Inventor	Pirim, Patrick	
	Art Unit	2121	
	Examiner Name	George B. Davis	
Total Number of Pages in This Submission	4	Attorney Docket Number	20046H-000100US

ENCLOSURES <small>(Check all that apply)</small>		
<input type="checkbox"/> Fee Transmittal Form <input type="checkbox"/> Fee Attached <input type="checkbox"/> Amendment/Reply <input type="checkbox"/> After Final <input type="checkbox"/> Affidavits/declaration(s) <input type="checkbox"/> Extension of Time Request <input type="checkbox"/> Express Abandonment Request <input checked="" type="checkbox"/> Information Disclosure Statement <input type="checkbox"/> Certified Copy of Priority Document(s) <input type="checkbox"/> Response to Missing Parts/Incomplete Application <input type="checkbox"/> Response to Missing Parts under 37 CFR 1.52 or 1.53	<input type="checkbox"/> Drawing(s) <input type="checkbox"/> Licensing-related Papers <input type="checkbox"/> Petition <input type="checkbox"/> Petition to Convert to a Provisional Application <input type="checkbox"/> Power of Attorney, Revocation Change of Correspondence Address <input type="checkbox"/> Terminal Disclaimer <input type="checkbox"/> Request for Refund <input type="checkbox"/> CD, Number of CD(s)	<input type="checkbox"/> After Allowance Communication to Group <input type="checkbox"/> Appeal Communication to Board of Appeals and Interferences <input type="checkbox"/> Appeal Communication to Group (Appeal Notice, Brief, Reply Brief) <input type="checkbox"/> Proprietary Information <input type="checkbox"/> Status Letter <input checked="" type="checkbox"/> Other Enclosure(s) (please identify below): Return Postcard; References Cited (2)
Remarks: The Commissioner is authorized to charge any additional fees to Deposit Account 20-1430.		
<p>RECEIVED JUN 28 2004 Technology Center 2100</p>		

SIGNATURE OF APPLICANT, ATTORNEY, OR AGENT	
Firm or Individual name	Townsend and Townsend and Crew LLP Gerald T. Gray Reg. No. 41,797
Signature	<i>Gerald T. Gray</i>
Date	June 17, 2004

CERTIFICATE OF TRANSMISSION/MAILING			
I hereby certify that this correspondence is being facsimile transmitted to the USPTO or deposited with the United States Postal Service with sufficient postage as first class mail in an envelope addressed to: Commissioner for Patents, P.O. Box 1450, Alexandria, VA 22313-1450 on the date shown below.			
Typed or printed name	Marta R. Vanegas		
Signature	<i>Marta Vanegas</i>	Date	June 17, 2004

60242565 v1

I hereby certify that this correspondence is being deposited with the United States Postal Service as first class mail in an envelope addressed to:

PATENT
Attorney Docket No.: 20046H-000100US
Client Reference No.: 308L US 3772

Commissioner for Patents
P.O. Box 1450
Alexandria, VA 22313-1450

On

June 17, 2004



TOWNSEND and TOWNSEND and CREW LLP

By:

Marta Vanegas

IN THE UNITED STATES PATENT AND TRADEMARK OFFICE

In re application of:

Patrick Pirim

Application No.: 09/792,436

Filed: February 23, 2001

For: METHOD AND DEVICE FOR
AUTOMATIC VISUAL PERCEPTION

Examiner: George B. Davis

Art Unit: 2121

SUPPLEMENTAL INFORMATION
DISCLOSURE STATEMENT UNDER 37
CFR §1.97 and §1.98

RECEIVED

JUN 28 2004

Technology Center 2100

Commissioner for Patents
P.O. Box 1450
Alexandria, VA 22313-1450

Sir:

The references cited on attached form PTO/SB/08A are being called to the attention of the Examiner. Copies of the references are enclosed.

It is respectfully requested that the cited references be expressly considered during the prosecution of this application, and the references be made of record therein and appear among the "references cited" on any patent to issue therefrom.

As provided for by 37 CFR 1.97(g) and (h), no inference should be made that the information and references cited are prior art merely because they are in this statement and no representation is being made that a search has been conducted or that this statement encompasses all the possible relevant information.

This IDS is being filed before the mailing date of the final Office Action or Notice of Allowance.

CERTIFICATION

I hereby certify that no item of information contained in the Information Disclosure Statement filed herewith was cited in a communication from a foreign patent office in a counterpart foreign application, and, to my knowledge after making reasonable inquiry, no item of information contained in this Information Disclosure Statement was known to any individual designated in 37 CFR 1.56(c) more than three months prior to the filing of this Information Disclosure Statement.

Applicant believes that no fee is required for submission of this statement. However, if a fee is required, the Commissioner is authorized to deduct such fee from the undersigned's Deposit Account No. 20-1430. Please deduct any additional fees from, or credit any overpayment to, the above-noted Deposit Account.

Respectfully submitted,

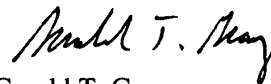

Gerald T. Gray
Reg. No. 41,797

TOWNSEND and TOWNSEND and CREW LLP
Two Embarcadero Center, Eighth Floor
San Francisco, California 94111-3834
Tel: 925-472-5000
Fax: 925-472-8895
GTG:mrv

60242432 v1



UNITED STATES PATENT AND TRADEMARK OFFICE

UNITED STATES DEPARTMENT OF COMMERCE
United States Patent and Trademark Office
Address: COMMISSIONER FOR PATENTS
P.O. Box 1480
Alexandria, Virginia 22313-1450
www.uspto.gov

APPLICATION NO.	FILING DATE	FIRST NAMED INVENTOR	ATTORNEY DOCKET NO.	CONFIRMATION NO.
09/792,436	02/23/2001	Patrick Pirim	20046H-000100	9956

20350 7590 03/26/2004

TOWNSEND AND TOWNSEND AND CREW, LLP
TWO EMBARCADERO CENTER
EIGHTH FLOOR
SAN FRANCISCO, CA 94111-3834

EXAMINER

DAVIS, GEORGE B

ART UNIT PAPER NUMBER

2121

DATE MAILED: 03/26/2004

Please find below and/or attached an Office communication concerning this application or proceeding.

PR4

Office Action Summary

Application No. 091792436	Applicant(s) PATRIC DIRIM
Examiner George Davis	Group Art Unit 2121

—The MAILING DATE of this communication appears on the cover sheet beneath the correspondence address—

Period for Reply

A SHORTENED STATUTORY PERIOD FOR REPLY IS SET TO EXPIRE Three MONTH(S) FROM THE MAILING DATE OF THIS COMMUNICATION.

- Extensions of time may be available under the provisions of 37 CFR 1.136(a). In no event, however, may a reply be timely filed after SIX (6) MONTHS from the mailing date of this communication.
- If the period for reply specified above is less than thirty (30) days, a reply within the statutory minimum of thirty (30) days will be considered timely.
- If NO period for reply is specified above, such period shall, by default, expire SIX (6) MONTHS from the mailing date of this communication.
- Failure to reply within the set or extended period for reply will, by statute, cause the application to become ABANDONED (35 U.S.C. § 133).

Status

- Responsive to communication(s) filed on _____
- This action is FINAL.
- Since this application is in condition for allowance except for formal matters, prosecution as to the merits is closed in accordance with the practice under *Ex parte Quayle*, 1935 C.D. 111; 453 O.G. 213.

Disposition of Claims

- Claim(s) 1-28 is/are pending in the application.
- Of the above claim(s) _____ is/are withdrawn from consideration.
- Claim(s) 17-28 is/are allowed.
- Claim(s) 1-16 is/are rejected.
- Claim(s) _____ is/are objected to.
- Claim(s) _____ are subject to restriction or election requirement.

Application Papers

- See the attached Notice of Draftsperson's Patent Drawing Review, PTO-948.
- The proposed drawing correction, filed on _____ is approved disapproved.
- The drawing(s) filed on _____ is/are objected to by the Examiner.
- The specification is objected to by the Examiner.
- The oath or declaration is objected to by the Examiner.

Priority under 35 U.S.C. § 119 (a)-(d)

- Acknowledgment is made of a claim for foreign priority under 35 U.S.C. § 119(a)-(d).
 - All Some* None of the CERTIFIED copies of the priority documents have been received.
 - received in Application No. (Series Code/Serial Number) _____
 - received in this national stage application from the International Bureau (PCT Rule 1.7.2(a)).
- *Certified copies not received: _____

Attachment(s)

- Information Disclosure Statement(s), PTO-1449, Paper No(s) 3, 6 and 7 Interview Summary, PTO-413
- Notice of Reference(s) Cited, PTO-892 Notice of Informal Patent Application, PTO-152
- Notice of Draftsperson's Patent Drawing Review, PTO-948 Other _____

Office Action Summary

Art Unit: 2121

DETAILED ACTION

Drawings

1. The drawings are objected to because Figures 6-11 and 21 should show arrow heads at the input and output of devices and the word "NO" is missing from connections. Fig. 13 should read "Fig. 13a". Fig. 13a should read "Fig. 13b". Fig. 13b should read "Fig. 13c". Fig. 13c should read "Fig. 13d". Fig. 15 should read "Fig. 15a". Fig. 15a should read "Fig. 15b". Fig. 31 should read "Fig. 31a". Fig. 31a should read "Fig. 31b". A proposed drawing correction or corrected drawings are required in reply to the Office action to avoid abandonment of the application. The objection to the drawings will not be held in abeyance.

Claim Objections

2. Claims 3-16 are objected to because of the following informalities: claim 3, line 29, before "the" insert -- wherein --. Appropriate correction is required.

Claim Rejections - 35 U.S.C. § 112

3. The following is a quotation of the second paragraph of 35 U.S.C. 112:

The specification shall conclude with one or more claims particularly pointing out and distinctly claiming the subject matter which the applicant regards as his invention.

Art Unit: 2121

Claims 3-16 are rejected under 35 U.S.C. 112, second paragraph, as being indefinite for failing to particularly point out and distinctly claim the subject matter which applicant regards as the invention.

Claim 3 recites the limitation "the course of time" in lines 3 and 4.

Claim 3 recites the limitation "the space" and "the pixal" in line 7.

Claim 3 recites the limitation "the value" and "the result of comparison" in lines 15 and 16.

Claim 3 recites the limitation "the classifier" in line 17.

Claim 3 recites the limitation "the counter" in line 26.

Claim 3 recites the limitation "the content of analysis memory" in lines 30 and 31.

Claim 3 recites the limitation "the beginning of each frame" in line 32.

Claim 3 recites the limitation "the analysis output register" and "the sequence" in line 37.

There are insufficient antecedent basis for these limitations in the claim.

4. The following is a quotation of the appropriate paragraphs of 35 U.S.C. 102 that form the basis for the rejections under this section made in this Office action:

A person shall be entitled to a patent unless -

(b) the invention was patented or described in a printed publication in this or a foreign country or in public use or on sale in this country, more than one year prior to the date of application for patent in the United States.

Claims 1 and 2 rejected under 35 U.S.C. 102(b) as being clearly anticipated by Ric Ka et al, U.S. Pat. No. 5359533.

Art Unit: 2121

As per claim 1, Ric discloses data bus, time coincidences bus and a histogram unit (column 5, lines 59-68 and column 6, lines 1-10).

As per claim , Ric discloses histogram matrix (device 7).

Allowable Subject Matter

5. Claims 3-16 would be allowable if rewritten or amended to overcome the rejection(s) under 35 U.S.C. 112, 2nd paragraph, set forth in this Office action.

6. Claims 17-28 are allowed.

7. Any inquiry concerning this communication or earlier communications from the examiner should be directed to George Davis whose telephone number is (703) 305-3891. The examiner can normally be reached on Monday through Thursday from 8:00 am to 6:30 pm.

If attempts to reach the examiner by telephone are unsuccessful, the examiner's supervisor, Anil Khatri, can be reached on (703) 305-0282. The fax phone number for the organization where this application or proceeding is assigned is (703) 746-7240.

Any inquiry of a general nature or relating to the status of this application or proceeding should be directed to the receptionist whose telephone number is (703) 305-3900.

Application/Control Number: 09/792436

Page 5

Art Unit: 2121

March 20, 2004

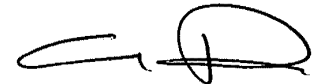

GEORGE B. DAVIS

PRIMARY PATENT EXAMINER

09/792436

FORM PTO-1449 (Modified)		Attorney Docket No.: 20046H-000100US		Application No.: Unassigned		
LIST OF PATENTS AND PUBLICATIONS FOR APPLICANT'S INFORMATION DISCLOSURE STATEMENT (Use several sheets if necessary)				Applicant: Patrick Pirim		
				Filing Date: Herewith 2/23/01		
				Group: Unassigned 2121		
Reference Designation		U.S. PATENT DOCUMENTS			Page 1	
Examiner Initial	Document No.	Date	Name	Class	Sub-class	Filing Date (If Appropriate)
GAA	5,793,888	08/11/98	Delanoy	382	219	
AB						
AC						
AD						
AE						
AF						
AG						
AH						
AI						
AJ						
AK						
AL						
FOREIGN PATENT DOCUMENTS						
	Document No.	Date	Country	Class	Sub-class	Translation (Yes/No)
GAM	EP 0 046 110	02/17/82	European			no
GAN	2 751 772	01/30/98	France			no
AO						
AP						
AQ						
AR						
OTHER ART (Including Author, Title, Date, Pertinent Pages, Etc.)						
AS						
AT						
AU						
AV						
AW						
EXAMINER	George Davis			DATE CONSIDERED		3/19/04

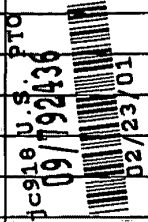

EXAMINER: Initial if reference considered, whether or not citation is in conformance with MPEP 609; Draw line through citation if not in conformance and not considered. Include copy of this form with next communication to applicant.

O I P E J C A E
JUN 14 2001

FORM PTO-1449 (Modified)		Attorney Docket No.: 20046H-000100US		Application No.: 09/792,436		
LIST OF PATENTS AND PUBLICATIONS FOR APPLICANT'S INFORMATION DISCLOSURE STATEMENT (Use several sheets if necessary)		Applicant: Patrick Pirim		Filing Date: February 23, 2001		
Reference Designation		U.S. PATENT DOCUMENTS			Page 1	
Examiner Initial	Document No.	Date	Name	Class	Sub-class	Filing Date (If Appropriate)
C.D	AA 5,712,729	01/27/98	Hashimoto	359	562	
C.D	AB 5,694,495	12/02/97	Hara et al.	382	324	
C.D	AC 5,488,430	01/30/96	Hong	348	699	
FOREIGN PATENT DOCUMENTS						
	Document No.	Date	Country	Class	Sub-class	Translation (Yes/No)
C.D	AD WO 00/11610	03/02/00	PCT			
C.D	AE WO 98/05002	02/05/98	PCT			
C.D	AF 2 611 063 A1	08/19/88	France			no
OTHER ART (Including Author, Title, Date, Pertinent Pages, Etc.)						
C.D	AG	Stephane G. Mallat, "A Theory for Multiresolution Signal Decomposition: The Wavelet Representation", IEEE Transactions on Pattern Analysis and Machine Intelligence, Vol. 11, No. 7, July 1989, pages 674-693.				
C.D	AH	John G. Daugman, "Complete Discrete 2-D Gabor Transforms by Neural Networks for Image Analysis and Compression", IEEE Transaction on Acoustics, Speech and Signal Processing, Vol. 36, No. 7, July 1988, pages 1169-1179.				
C.D	AI	Alberto Tomita, Jr., et al., "Hand Shape Extraction from a Sequence of Digitized Gray-Scale Images", IECON '94, 20th International Conference on Industrial Electronics, Control and Instrumentation, Vol. 3 of 3, Special Sessions, Signal Processing and Control, pages 1925-1930				
C.D	AJ	Giacomo Indiveri et al., "System Implementations of Analog VLSI Velocity Sensors", 1996 IEEE Proceedings of MicroNeuro '96, pages 15-22				
C.D	AK	Pierre-Francois Ruedi, "Motion Detection Silicon Retina Based on Event Correlations", 1996 IEEE Proceedings of MicroNeuro '96, pages 23-29				
C.D	AL	Revue Trimestrielle Des «Techniques de Lingenieur», "Instantanés Technique" Techniques De ingénieur, Mars 1997-N°5 (40F), ISSN 0994-0758,				
C.D	AM	Es Professionnels de Linformatique En Entreprise Magazine, "Objectif Securite Des Reseaux", N° 24, Janvier, 1997				
C.D	AN	Electronique International Hebdo, 5 Decembre 1996-N° 245, "Premier... oeil", Francoise Gru svelet (with translation)				
C.D	AO	Nabeel Al Adsani, "For Immediate Release The Generic Visual Perception Processor", October 10, 1997, page 1				
C.D	AP	Colin Johnson, "Vision Chip's Circuitry Has Its Eye Out For You", http://192.215.107.74/wire/news/1997/09/0913vision.html , pages 1-3				
C.D	AQ	The Japan Times, "British firm has eye on the future", Business & Technology, Tuesday, November 18, 1997, 4th Edition				
C.D	AR	Inside the Pentagon's, Inside Missile Defense, an exclusive biweekly report on U.S. missile defense programs, procurement and policymaking, "Missile Technology" Vol. 3, No. 16-August 13, 1997, page 5				
C.D	AS	Electronique, "Le Mechanisme de la Vision Humaine Dans Le Silicium", Electronique Le Mensuel Des Ingenieurs De Conception, Number 68, Mars 1997, ISSN 1157-1151 (with translation)				
C.D	AT	"Elektronik Revue" ER, Eine Elsevier-Thomas-Publikation, Jahrgang 8, Marz 1997, NR.3, ISSN0939-1134				
C.D	AU	"Un Processor de Perception Visuelle", LeHAUT PARLEUR, 25F Des solutions électroniques pour tous, N° 1856, 15 janvier 1997 (with translation)				
C.D	AV	"Realiser Un Decodeur Pour TV Numerique", Electronique, Le Mensuel Des Ingenieurs De Conception, Number 66, Janvier 1997				
C.D	AW	Groupe Revenu Français, Air & Cosmos Aviation International, "Un Calculateur De Perception Visuelle", Hebdomadaire, vendredi 6 decembre 1996, 34 Année, No 1590, 22F.				
EXAMINER		George Davis			DATE CONSIDERED 3/19/04	

EXAMINER: Initial if reference considered, whether or not citation is in conformance with MPEP 609; Draw line through citation if not in conformance and not considered. Include copy of this form with next communication to applicant. SF 1235257 v1



Under the Paperwork Reduction Act of 1995, no persons are required to respond to a collection of information unless it contains a valid OMB control number.

INFORMATION DISCLOSURE STATEMENT BY APPLICANT (use as many sheets as necessary)		Complete if Known	
Application Number	09/792,436	Filing Date	February 23, 2001
First Named Inventor	Pirim, Patrick	Art Unit	2121
Examiner Name	Unassigned	Attorney Docket Number	20046H-000100US
Sheet 1	of 2		

U.S. PATENT DOCUMENTS					
Examiner	Cite No. ¹	Document Number Number Kind Code ² (if known)	Publication Date MM-DD-YYYY	Name of Patentee or Applicant of Cited Document	Class/subclass Pages, Columns, Lines, Where Relevant Passages or Relevant Figures Appear
L.O.	AA	US-6,486,909 B1	11/28/02	Patrick Pirim	348/143
L.O.	AB	US-6,304,187 B1	10/16/01	Patrick Pirim	340/576
L.O.	AC	US-5,384,865	01/24/95	Jennifer C. Lovenidge	382/262
L.O.	AD	US-5,488,430	01/30/96	Sun H. Hong	348/1699
L.O.	AE	US-5,109,425	04/28/92	Teri B. Lawton	382/107
	AF	US-			
	AG	US-			
	AH	US-			
	AI	US-			
	AJ	US-			
	AK	US-			
	AL	US-			
	AM	US-			
	AN	US-			
	AO	US-			
	AP	US-			
	AQ	US-			
	AR	US-			
	AS	US-			
	AT	US-			

RECEIVED

APR 15 2003

Technology Center 2100

FOREIGN PATENT DOCUMENTS							
Examiner Initials*	Cite No. ¹	Foreign Patent Document		Publication Date MM-DD-YYYY	Name of Patentee or Applicant of Cited Document	Pages, Columns, Lines, Where Relevant Passages or Relevant Figures Appear	7 ⁶
		Country Code ²	Number ³ Kind Code ⁴ (if known)				
L.O.	AU	WO	99/36894	07/22/99	Patrick Pirim		<input type="checkbox"/>
L.O.	AV	EP	0 380 659 A1	08/08/90	Makoto Nagao et al.		<input type="checkbox"/>
L.O.	AW	EP	0 394 959 A2	10/31/90	Axel Korn		<input type="checkbox"/>
L.O.	AX	WO	99/36893	07/22/99	Patrick Pirim et al.		<input type="checkbox"/>
	AY						<input type="checkbox"/>
	AZ						<input type="checkbox"/>
	BA						<input type="checkbox"/>
	BB						<input type="checkbox"/>

Examiner Signature	George Davis	Date Considered	3/19/04
-----------------------	--------------	--------------------	---------

*EXAMINER: Initial if reference considered, whether or not citation is in conformance with MPEP 609. Draw line through citation if not in conformance and not considered. Include copy of this form with next communication to applicant.

¹ Applicant's unique citation designation number (optional). ² Kind Codes of U.S. Patent Documents at www.uspto.gov or MPEP 901.04. ³ Enter Office that issued the document, by the two-letter code (WIPO Standard ST.3). ⁴ For Japanese patent documents, the indication of the year of the reign of the Emperor must precede the serial number of the patent document. ⁵ Kind of document by the appropriate symbols as indicated on the document under WIPO Standard ST. 16 if possible. ⁶ Applicant is to place a check mark here if English language Translation is attached.

Burden Hour Statement: This form is estimated to take 2.0 hours to complete. Time will vary depending upon the needs of the individual case. Any comments on the amount of time you are required to complete this form should be sent to the Chief Information Officer, U.S. Patent and Trademark Office, Washington, DC 20231. DO NOT SEND FEES OR COMPLETED FORMS TO THIS ADDRESS. SEND TO: Assistant Commissioner for Patents, Washington, DC 20231
 WC 9055673 v1



PTO/SB/08B (10-01)

Approved for use through 10/31/2002. OMB 0651-0031
 U.S. Patent and Trademark Office: U.S. DEPARTMENT OF COMMERCE

Under the Paperwork Reduction Act of 1995, no persons are required to respond to a collection of information unless it contains a valid OMB control number

Substitute for form 1449B/PTO		Complete If Known	
INFORMATION DISCLOSURE STATEMENT BY APPLICANT (use as many sheets as necessary)		Application Number	09/792,436
		Filing Date	February 23, 2001
		First Named Inventor	Pirim, Patrick
		Art Unit	2621 2121
		Examiner Name	Unassigned
		Attorney Docket Number	20046H-000100US
Sheet	2	of	2

OTHER PRIOR ART -- NON PATENT LITERATURE DOCUMENTS			
Examiner Initials *	Cite No. ¹	Include name of the author (in CAPITAL LETTERS), title of the article (when appropriate), title of the item (book, magazine, journal, serial, symposium, catalog, etc.), date, page(s), volume-issue number(s), publisher, city and/or country where published.	T ²
C.D.	BC	KENICHI YAMADA, et al; "Image Understanding Based on Edge Histogram Method for Rear-End Collision Avoidance System", Vehicle Navigation & Information Systems Conference Proceedings; (1994), pp. 445-450 published 08/31/94; XP 000641348	
	BD		
	BE		
	BF		
	BG		
	BH		
	BI		
	BJ		
	BK		
	BL		
	BM		

RECEIVED
 APR 15 2003
 Technology Center 2100

Examiner Signature	George Davis	Date Considered	3/19/04
--------------------	--------------	-----------------	---------

*EXAMINER: Initial if reference considered, whether or not citation is in conformance with MPEP 809. Draw line through citation if not in conformance and not considered. Include copy of this form with next communication to applicant.

¹ Applicant's unique citation designation number (optional). ² Applicant is to place a check mark here if English language Translation is attached.

Burden Hour Statement: This form is estimated to take 2.0 hours to complete. Time will vary depending upon the needs of the individual case. Any comments on the amount of time you are required to complete this form should be sent to the Chief Information Officer, U.S. Patent and Trademark Office, Washington, DC 20231. DO NOT SEND FEES OR COMPLETED FORMS TO THIS ADDRESS. SEND TO: Assistant Commissioner for Patents, Washington, DC 20231.
 WC 9055673 v1

Notice of References Cited

Application No. 09/192436 Applicant(s) Patric Pirim
 Examiner George Davil Group Art Unit 2121 Page 1 of 1

U.S. PATENT DOCUMENTS

☆	DOCUMENT NO.	DATE	NAME	CLASS	SUBCLASS
A	US2002/0101432A	8/02	Ohara et al	345	589
B	5592237	1/97	Greenway et al	348	716
C	5359533	10/94	Ric Ka et al	702	78
D	5163095	11/92	Kosaka	382	133
E	5088488	2/92	Markowitz et al	607	27
F					
G					
H					
I					
J					
K					
L					
M					

FOREIGN PATENT DOCUMENTS

☆	DOCUMENT NO.	DATE	COUNTRY	NAME	CLASS	SUBCLASS
N						
O						
P						
Q						
R						
S						
T						

NON-PATENT DOCUMENTS

☆	DOCUMENT (Including Author, Title, Source, and Pertinent Pages)	DATE
U		
V		
W		
X		

* A copy of this reference is not being furnished with this Office action.
 (See Manual of Patent Examining Procedure, Section 707.05(a).)



Welcome to IEEE Xplore®

- Home
- What Can I Access?
- Log-out

Tables of Contents

- Journals & Magazines
- Conference Proceedings
- Standards

Search

- By Author
- Basic
- Advanced

Member Services

- Establish IEEE Web Account
- Access the IEEE Member Digital Library

Your search matched **2** of **1013964** documents.
A maximum of **500** results are displayed, **15** to a page, sorted by **Relevance** in **Descending** order.

Refine This Search:

You may refine your search by editing the current search expression or entering a new one in the text box.

(data <phrase> bus) and histogram

Check to search within this result set

Results Key:

JNL = Journal or Magazine **CNF** = Conference **STD** = Standard

1 An O(1) time algorithms for computing histogram and Hough transform on a cross-bridge reconfigurable array of processors

Kao, T.-W.; Horng, S.-J.; Wang, Y.-L.;
Systems, Man and Cybernetics, IEEE Transactions on , Volume: 25 , Issue: 4 , April 1995
Pages:681 - 687

[\[Abstract\]](#) [\[PDF Full-Text \(640 KB\)\]](#) **IEEE JNL**

2 PASIC. A sensor/processor array for computer vision

Chen, K.; Danielsson, P.E.; Astrom, A.;
Application Specific Array Processors, 1990. Proceedings of the International Conference on , 5-7 Sept. 1990
Pages:352 - 366

[\[Abstract\]](#) [\[PDF Full-Text \(472 KB\)\]](#) **IEEE CNF**

IEEE HOME | SEARCH IEEE | SHOP | WEB ACCOUNT | CONTACT IEEE



Membership Publications/Services Standards Conferences Careers/Jobs

IEEE Xplore®
RELEASE 1.6

Welcome
United States Patent and Trademark
Office

IEEE Xplore®
1 Million Documents
1 Million Users
...and counting

Help FAQ Terms IEEE Quick Links

» Search Results

Welcome to IEEE Xplore®

- Home
- What Can I Access?
- Log-out

Tables of Contents

- Journals & Magazines
- Conference Proceedings
- Standards

Search

- By Author
- Basic
- Advanced

Member Services

- Join IEEE
- Establish IEEE Web Account
- Access the IEEE Member Digital Library

Your search matched **0** of **1013964** documents.
A maximum of **500** results are displayed, **15** to a page, sorted by **Relevance** in **Descending** order.

Refine This Search:

You may refine your search by editing the current search expression or entering a new one in the text box.

(time <phrase> BUS) and (data <phrase> bus)

Search

Check to search within this result set

Results Key:

JNL = Journal or Magazine **CNF** = Conference **STD** = Standard

Results:

No documents matched your query.

[Home](#) | [Log-out](#) | [Journals](#) | [Conference Proceedings](#) | [Standards](#) | [Search by Author](#) | [Basic Search](#) | [Advanced Search](#) | [Join IEEE](#) | [Web Account](#) | [New this week](#) | [OPAC Linking Information](#) | [Your Feedback](#) | [Technical Support](#) | [Email Alerting](#) | [No Robots Please](#) | [Release Notes](#) | [IEEE Online Publications](#) | [Help](#) | [FAQ](#) | [Terms](#) | [Back to Top](#)

Copyright © 2004 IEEE — All rights reserved

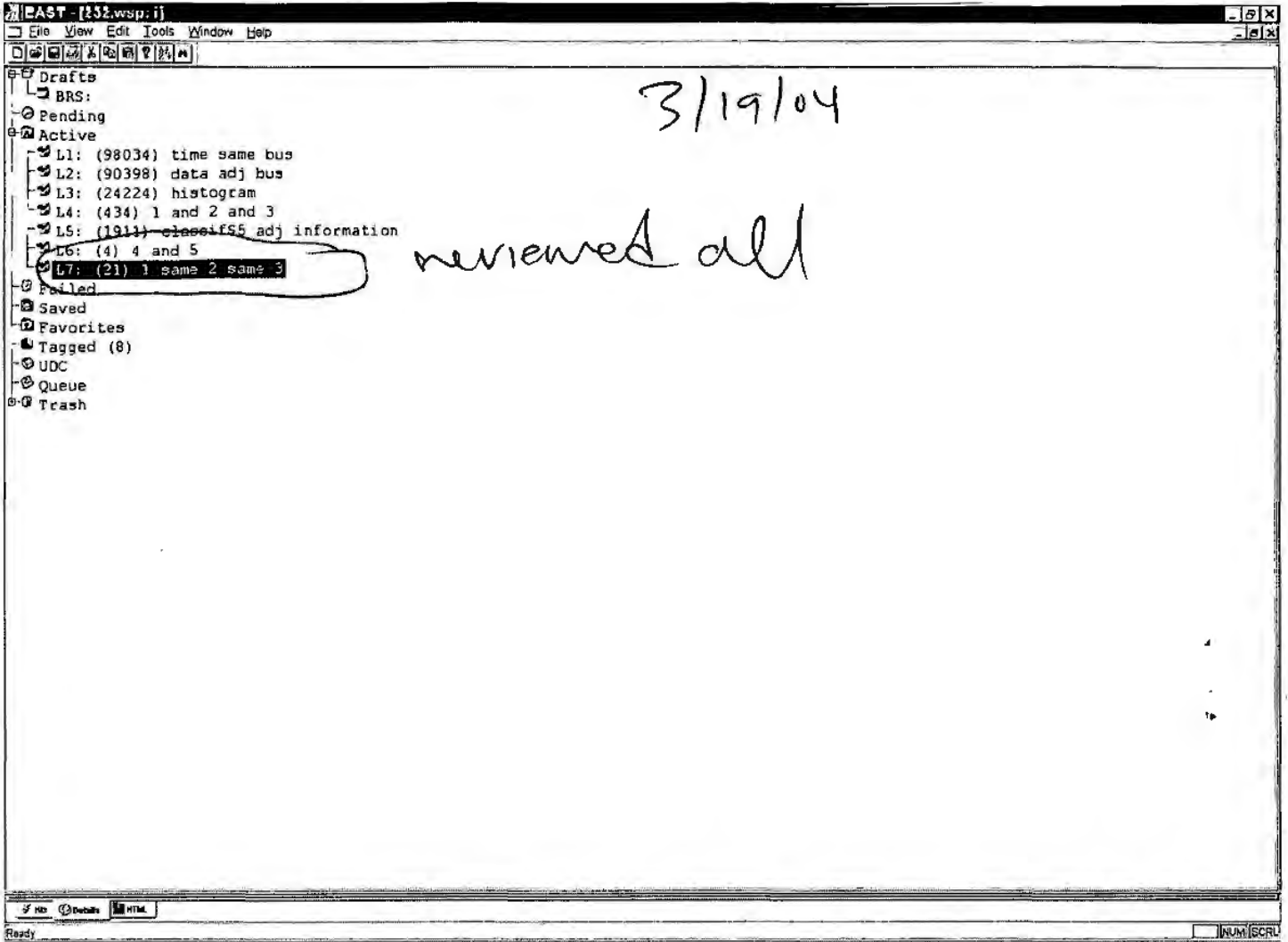



I hereby certify that this correspondence is being deposited with the United States Postal Service as first class mail in an envelope addressed to:

Commissioner for Patents
Washington, D.C. 20231

On April 9, 2003

TOWNSEND and TOWNSEND and CREW LLP

By Lawanna J. Baird

PATENT
Attorney Docket No.: 20046H-000100US
Client Reference No.: 308L US 3772

2122
#17
15T
5-2-03

IN THE UNITED STATES PATENT AND TRADEMARK OFFICE

In re application of:

Patrick Pirim

Application No.: 09/792,436

Filed: February 23, 2001

For: METHOD AND DEVICE FOR
AUTOMATIC VISUAL PERCEPTION

Examiner: Unassigned

Art Unit: 2122

RECEIVED

APR 15 2003

Technology Center 2100

SUPPLEMENTAL INFORMATION
DISCLOSURE STATEMENT UNDER 37
CFR §1.97 and §1.98

Commissioner for Patents
Washington, D.C. 20231

Sir:

The references cited on attached form PTO/SB/08A and PTO/SB/08B are being called to the attention of the Examiner. Copies of the references are enclosed. It is respectfully requested that the cited references be expressly considered during the prosecution of this application, and the references be made of record therein and appear among the "references cited" on any patent to issue therefrom.

As provided for by 37 CFR 1.97(g) and (h), no inference should be made that the information and references cited are prior art merely because they are in this statement and no representation is being made that a search has been conducted or that this statement encompasses all the possible relevant information.

Patrick Pirim
Application No.: 09/792,436
Page 2

PATENT

Applicant believes that no fee is required for submission of this statement. However, if a fee is required, the Commissioner is authorized to deduct such fee from the undersigned's Deposit Account No. 20-1430. Please deduct any additional fees from, or credit any overpayment to, the above-noted Deposit Account.

Respectfully submitted,

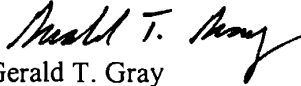
Gerald T. Gray
Reg. No. 41,797

TOWNSEND and TOWNSEND and CREW LLP
Two Embarcadero Center, 8th Floor
San Francisco, California 94111-3834
Tel: 925-472-5000
Fax: 925-472-8895
GTG/ljb
WC 9055673 v1

This Page Is Inserted by IFW Operations
and is not a part of the Official Record

BEST AVAILABLE IMAGES

Defective images within this document are accurate representations of the original documents submitted by the applicant.

Defects in the images may include (but are not limited to):

- BLACK BORDERS
- TEXT CUT OFF AT TOP, BOTTOM OR SIDES
- FADED TEXT
- ILLEGIBLE TEXT
- SKEWED/SLANTED IMAGES
- COLORED PHOTOS
- BLACK OR VERY BLACK AND WHITE DARK PHOTOS
- GRAY SCALE DOCUMENTS

IMAGES ARE BEST AVAILABLE COPY.

**As rescanning documents *will not* correct images,
please do not report the images to the
Image Problems Mailbox.**

PCT

ORGANISATION MONDIALE DE LA PROPRIÉTÉ INTELLECTUELLE
Bureau international

DEMANDE INTERNATIONALE PUBLIÉE EN VERTU DU TRAITE DE COOPERATION EN MATIÈRE DE BREVETS (PCT)

(51) Classification internationale des brevets ⁶ : G08B 21/00	A1	(11) Numéro de publication internationale: WO 99/36894 (43) Date de publication internationale: 22 juillet 1999 (22.07.99)
<p>(21) Numéro de la demande internationale: PCT/FR99/00060</p> <p>(22) Date de dépôt international: 14 janvier 1999 (14.01.99)</p> <p>(30) Données relatives à la priorité: 98/00378 15 janvier 1998 (15.01.98) FR</p> <p>(71) Déposant (pour tous les Etats désignés sauf US): CARLUS MAGNUS LIMITED [GB/GB]; Victoria House, Main Street (GI).</p> <p>(71)(72) Déposant et inventeur: PIRIM, Patrick [FR/FR]; 56, rue Pamy, F-75013 Paris (FR).</p> <p>(74) Mandataires: PHELIP, Bruno etc.; Cabinet Harlé & Pélip, 7, rue de Madrid, F-75008 Paris (FR).</p>	<p>(81) Etats désignés: AL, AM, AT, AU, AZ, BA, BB, BG, BR, BY, CA, CH, CN, CU, CZ, DE, DK, EE, ES, FI, GB, GD, GE, GH, GM, HR, HU, ID, IL, IN, IS, JP, KE, KG, KP, KR, KZ, LC, LK, LR, LS, LT, LU, LV, MD, MG, MK, MN, MW, MX, NO, NZ, PL, PT, RO, RU, SD, SE, SG, SI, SK, SL, TJ, TM, TR, TT, UA, UG, US, UZ, VN, YU, ZW, brevet ARIPO (GH, GM, KE, LS, MW, SD, SZ, UG, ZW), brevet eurasien (AM, AZ, BY, KG, KZ, MD, RU, TJ, TM), brevet européen (AT, BE, CH, CY, DE, DK, ES, FI, FR, GB, GR, IE, IT, LU, MC, NL, PT, SE), brevet OAPI (BF, BJ, CF, CG, CI, CM, GA, GN, GW, ML, MR, NE, SN, TD, TG).</p> <p>Publiée Avec rapport de recherche internationale.</p>	
(54) Titre: METHOD AND DEVICE FOR DETECTING DROWSINESS AND PREVENTING A DRIVER OF A MOTOR VEHICLE FROM FALLING ASLEEP		
(54) Titre: PROCÉDE ET DISPOSITIF POUR DETECTER ET PREVENIR L'ENDORMISSEMENT DU CONDUCTEUR D'UN VEHICULE AUTOMOBILE		
(57) Abstract		
<p>The invention relates to a method and device using an optoelectronic sensor (10) in combination with an electronic unit (19), in accordance with French patent application no. 96.09420, filed on 25 July 1996 and International patent application (PCT) PCT/FR97/01354 filed on 22 July 1997, arranged inside the motor vehicle. The sensor is adjusted in line with the head of the driver sitting in said motor vehicle at the same time as the inner rear-view mirror, which comprises a one-way mirror (9) behind which the sensor (10) is positioned. After detecting the presence of a driver seated in the motor vehicle they frame first the whole face and then the eyes of the driver in the video signal raster emitted by the sensor (10) aided by the electronic unit (19) and then determine the successive durations of blinking episodes, which are compared with a limit value situated between one duration typical of an awake person and another duration typical of a drowsy person. A signal (transmitted by an alarm unit 22) suitable for waking the driver is triggered when the duration of blinking exceeds the limit.</p>		

(57) Abrégé

Le procédé et le dispositif selon l'invention mettent en oeuvre un ensemble capteur optoélectronique (10) - unité électronique (19), selon la demande de brevet français N° 96.09420 déposée le 26 juillet 1996 et la demande de brevet international (P.C.T.) PCT/FR97/01354 déposée le 22 juillet 1997, disposé à l'intérieur du véhicule automobile, le capteur étant orienté vers la tête du conducteur en place dans celui-ci en même temps que le rétroviseur intérieur qui comporte un miroir sans tain (9) derrière lequel est disposé le capteur (10). Ils réalisent, après détection de la présence d'un conducteur en place dans le véhicule, le cadrage d'abord du visage entier, puis des yeux, de celui-ci dans les trames du signal vidéo débité par le capteur (10), grâce à l'unité électronique (19), et ensuite la détermination des durées successives des clignements des yeux, celles-ci étant comparées à un seuil compris entre une telle durée pour une personne éveillée et une telle durée pour une personne somnolente et un signal (émis par une alarme (22) apte à éveiller le conducteur étant déclenché lorsque la durée de ses clignements dépasse ledit seuil.

UNIQUEMENT A TITRE D'INFORMATION

Codes utilisés pour identifier les Etats parties au PCT, sur les pages de couverture des brochures publiant des demandes internationales en vertu du PCT.

AL	Albanie	ES	Espagne	LS	Lesotho	SI	Slovénie
AM	Arménie	FI	Finlande	LT	Lituanie	SK	Slovaquie
AT	Autriche	FR	France	LU	Luxembourg	SN	Sénégal
AU	Australie	GA	Gabon	LV	Lettonie	SZ	Swaziland
AZ	Azerbaïdjan	GB	Royaume-Uni	MC	Monaco	TD	Tchad
BA	Bosnie-Herzégovine	GE	Géorgie	MD	République de Moldova	TG	Togo
BB	Barbade	GH	Ghana	MG	Madagascar	TJ	Tadjikistan
BE	Belgique	GN	Guinée	MK	Ex-République yougoslave de Macédoine	TM	Turkménistan
BF	Burkina Faso	GR	Grèce	ML	Mali	TR	Turquie
BG	Bulgarie	HU	Hongrie	MN	Mongolie	TT	Trinité-et-Tobago
BJ	Bénin	IE	Irlande	MR	Mauritanie	UA	Ukraine
BR	Brésil	IL	Israël	MW	Malawi	UG	Ouganda
BY	Bélarus	IS	Islande	MX	Mexique	US	Etats-Unis d'Amérique
CA	Canada	IT	Italie	NE	Niger	UZ	Ouzbékistan
CF	République centrafricaine	JP	Japon	NL	Pays-Bas	VN	Viet Nam
CG	Congo	KE	Kenya	NO	Norvège	YU	Yougoslavie
CH	Suisse	KG	Kirghizistan	NZ	Nouvelle-Zélande	ZW	Zimbabwe
CI	Côte d'Ivoire	KP	République populaire démocratique de Corée	PL	Pologne		
CM	Cameroun	KR	République de Corée	PT	Portugal		
CN	Chine	KZ	Kazakhstan	RO	Roumanie		
CU	Cuba	LC	Sainte-Lucie	RU	Fédération de Russie		
CZ	République tchèque	LJ	Liechtenstein	SD	Soudan		
DE	Allemagne	LK	Sri Lanka	SE	Suède		
DK	Danemark	LR	Libéria	SG	Singapour		
EE	Estonie						

PROCEDE ET DISPOSITIF POUR DETECTER ET PREVENIR L'ENDORMISSEMENT DU CONDUCTEUR D'UN VEHICULE AUTOMOBILE

La présente invention a pour objet un procédé et un dispositif pour surveiller en continu l'état de vigilance du conducteur d'un véhicule automobile, afin de détecter et prévenir une tendance éventuelle à l'endormissement de celui-ci.

On sait qu'une proportion non négligeable, sinon importante, des accidents, sur route résultent de l'endormissement, total ou partiel (sommolence), du conducteur d'un véhicule automobile (auto particulière, auto utilitaire, camionnette, camion), avec pour résultat de nombreux morts et blessés.

On voit donc l'intérêt, humain et économique, à éviter l'endormissement d'un conducteur en provoquant une alarme, notamment sonore, dès que celui-ci tend à s'assoupir, afin de l'éveiller.

Pour détecter la tendance à l'endormissement d'un conducteur, on a proposé sur un véhicule automobile

- d'une part, de détecter la variation de l'actionnement du volant par un conducteur qui tend à s'endormir et
- d'autre part, de détecter la variation des déplacements verticaux des paupières d'un conducteur qui tend à s'endormir.

La présente invention met en œuvre une détection du second type (surveillance des déplacements des paupières) et elle est basée sur une constatation physiologique, à savoir la modification de la durée des clignements des yeux, ainsi qu'éventuellement des intervalles de temps entre deux clignements successifs, donc la cadence des clignements, lorsqu'une personne passe de l'état éveillé à l'état de somnolence précédant l'endormissement de celui-ci : la durée des clignements d'œil d'une personne est de l'ordre de 100 à 200 ms (millisecondes) lorsqu'elle est éveillée et de l'ordre de 500 à 800 ms lorsqu'elle somnole, tandis que l'intervalle de temps séparant deux clignements successifs, qui est sensiblement constant à l'état éveillé, varie dans une plage relativement large à l'état somnolent. C'est la variation de la durée des clignements qui est essentiellement mise en œuvre dans le cadre de l'invention.

Le procédé et le dispositif selon l'invention décèlent l'augmentation de la durée des clignements des yeux du conducteur et déclenchent une alarme, sonore ou autre, lorsque cette durée dépasse un seuil déterminé, compris en particulier entre 200 et 500 ms, par exemple égal à 350 ms, ce seuil étant éventuellement modifiable en fonction de la physiologie du conducteur.

Dans la demande de brevet français N° 96.09420 déposée le 26 juillet 1996 et la demande de brevet international (P.C.T.) PCT/FR97 /01354 déposée le 22 juillet 1997, en invoquant la priorité de ladite demande de brevet français, l'inventeur de ces deux demandes étant également l'inventeur de la présente invention, on a décrit un procédé et un dispositif, fonctionnant en temps réel, pour le repérage et la localisation d'une zone en mouvement relatif dans une scène, ainsi que pour la détermination de la vitesse et de la direction du déplacement.

Parmi les applications envisagées de ce procédé et ce dispositif, on a décrit, dans lesdites demandes de brevet, la mise en œuvre de ceux-ci pour l'observation et la surveillance d'une zone constituée par la tête d'un conducteur automobile, afin de détecter et prévenir l'endormissement de celui-ci.

Selon cette application particulière des procédé et dispositif desdites demandes de brevet :

- on produisait un signal vidéo représentatif, en temps réel, des images successives des yeux du conducteur ;
- on traitait ce signal vidéo pour, successivement et en continu,
 - détecter, dans l'image des yeux de ce conducteur, les déplacements verticaux des paupières représentatifs du clignement de celles-ci ;
 - déterminer la cadence de ces déplacements verticaux et
 - repérer les cadences inférieures à un certain seuil, qui correspond sensiblement à la cadence de clignement à l'état éveillé du conducteur ; et
- on déclenchait une alarme en cas de franchissement de ce seuil vers le bas par lesdites cadences, afin d'éveiller le conducteur.

La présente invention a pour objet des perfectionnements aux procédé et dispositif des demandes de brevet précitées, en ce qui concerne leur application à la surveillance d'un conducteur automobile, afin de détecter sa tendance éventuelle à l'endormissement.

Ainsi l'article de Hiroshi Ueno et al. intitulé « Development of drowsiness detection system », publié dans la revue de l'Institute of Electrical and Electronics Engineers (IEEE) du 31 août 1994 pages 15-20, analyse les différentes techniques de détection de l'assoupissement du conducteur d'un véhicule automobile au volant. En particulier on mentionne la mise en œuvre d'une caméra vidéo associée à un calculateur de traitement de l'image vidéo, au moyen d'un logiciel réalisant, d'une part, la détection du visage du con-

ducteur, notamment d'un rectangle englobant un oeil, et, d'autre part, du rapport des durées des yeux ouverts et des yeux fermés pour déterminer des critères d'endormissement.

- 5 La demande de brevet allemand publiée DE 197 15519 et la demande de brevet français publiée correspondante n° 2.747.346 décrivent un appareil et un procédé d'estimation du niveau de somnolence du conducteur d'un véhicule mettant en oeuvre une caméra vidéo disposée aux pieds du conducteur du véhicule et un
- 10 calculateur de traitement de l'image fournie par la caméra, avec un logiciel qui détecte les clignements des yeux par détermination du temps écoulé entre le début et la fin des clignements. En particulier, une unité 10 du calculateur réalise
- 15 ◦ la mémorisation de l'image vidéo et le traitement de celle-ci afin de déterminer une région comprenant les yeux du conducteur,
 - la détection de l'intervalle de temps entre la fermeture des paupières du conducteur et l'ouverture complète de celles-ci; et
 - 20 ◦ un traitement dans une mémoire 11 et une unité de calcul 22, en combinaison avec l'unité 10, afin de calculer un rapport d'apparition de clignements lents.

- La demande de brevet internationale publiée WO 97/01246 a pour objet un système de sécurité comportant une caméra vidéo disposée dans le rétroviseur
- 20 intérieur d'un véhicule automobile et un écran vidéo déporté pour l'analyse de ce qui se passe dans le véhicule et autour de celui-ci, ainsi que de ce qui s'est passé grâce à l'enregistrement du signal vidéo de sortie de la caméra. Il s'agit en fait d'une caméra cachée (dans le rétroviseur), afin d'échapper aux regards des intrus, et qui observe une aire étendue couvrant l'intérieur et l'environnement du véhicule, l'enregistrement permettant de repérer plus tard ce qui s'est passé dans cette aire
- 25 (page 6, lignes 13 à 19), et non pas d'un capteur dont l'angle de vision est sensiblement limité au visage du conducteur afin de détecter son endormissement éventuel et provoquer son éveil.

- Ces documents antérieurs mettent en oeuvre une véritable caméra vidéo et un calculateur externe, la détection du clignement des yeux dans ledit article et
- 30 lesdites demandes française et allemande requérant une unité complexe de traitement, tandis que ladite demande internationale ne résout pas le problème de la détection de l'endormissement. le conducteur s'il sommeille n'étant capable de regarder ni l'écran vidéo, ni l'enregistrement des images vidéo. On voit donc que ce document ne concerne pas le même domaine technique que les deux documents
- 35 précédents.

Par rapport à ces documents antérieurs, la présente invention réalise une meilleure approche de la prise de mesure du clignement des yeux du conducteur ; en effet

- elle permet de mettre en œuvre dans le rétroviseur du véhicule un simple capteur (éventuellement le capteur d'une caméra vidéo miniature), notamment un capteur MOS, qui n'est pas forcément au format vidéo classique ;
- elle réalise un mouvement de l'axe optique du capteur lié au déplacement du rétroviseur par le conducteur afin de diriger ledit axe vers le visage du conducteur ;
- elle permet une perception visuelle intégrée, un circuit intégré assurant une détection immédiate des mouvements des paupières ;
- elle met en œuvre un processeur très simple pour le traitement des informations fournies par le capteur ;
- elle permet l'intégration possible dans une puce électronique (chip) du capteur, de l'électronique associée à celui-ci et du calculateur, le tout disposé dans le rétroviseur ;
- elle donne la possibilité d'associer une telle puce disposée à l'intérieur du rétroviseur au processeur prévu dans le tableau de bord, le rétroviseur constituant ainsi un appareil intelligent de détection de l'endormissement, d'un coût raisonnable du fait qu'il comporte, par rapport à un rétroviseur intérieur classique, simplement une puce et un dispositif mécanique d'orientation de cette puce supplémentaire.

Dans ces conditions, l'invention a tout d'abord pour objet un procédé pour surveiller en continu l'état de vigilance du conducteur d'un véhicule automobile, afin de détecter et prévenir une tendance éventuelle à l'endormissement de celui-ci,

qui consiste

- à produire un signal vidéo représentatif, en temps réel, des images successives d'au moins le visage du conducteur ;
- à traiter ce signal, successivement et en continu, pour
 - détecter, dans ce signal, la portion correspondant effectivement à l'image de la tête du conducteur,
 - déterminer la valeur d'un paramètre relatif au clignement des paupières, qui se modifie notablement lors du passage de l'état éveillé à l'état somnolent du conducteur de part et d'autre d'un seuil, et
 - repérer, en temps réel, le franchissement, par la valeur de ce paramètre, de ce seuil représentatif du passage de l'état éveillé à l'état somnolent du conducteur ; et

- à déclencher, en réponse au franchissement de ce seuil, une alarme apte à réveiller le conducteur ;

et qui est caractérisé en ce que

- d'une part, le signal vidéo est produit en utilisant un capteur optoélectronique solidaire d'un rétroviseur du véhicule automobile, dimensionné et disposé pour recevoir
5 essentiellement l'image du visage du conducteur en place sur son siège et ayant son axe optique de réception des rayons lumineux dirigé vers la tête du conducteur lorsque le rétroviseur est correctement orienté ; et

- d'autre part, le traitement dudit signal vidéo consiste, après avoir détecté la présence du
10 conducteur à sa place, à, successivement et en continu ,

- détecter, à partir d'une analyse des pixels en déplacement entre deux trames successives de même nature dudit signal vidéo, les déplacements horizontaux du conducteur, afin de cadrer le visage de celui-ci dans les trames correspondantes successives du signal vidéo,

- 15 • détecter, à partir d'une analyse des pixels en déplacement entre deux trames successives de même nature dudit signal vidéo, les déplacements verticaux dans le visage, ainsi cadré, du conducteur, afin de cadrer les yeux de celui-ci,

- déterminer, à partir d'une analyse des pixels en déplacement entre deux trames successives de même nature dudit signal vidéo, les durées successives des
20 clignements des yeux, ainsi cadrés, de celui-ci, ces durées constituant le dit paramètre,

- comparer ces durées successives des clignements, ainsi déterminées, à un seuil représentatif du passage de l'état éveillé à l'état somnolent du conducteur, et

- 25 • déclencher, lorsque les durées de clignement dépassent vers le haut le dit seuil, une alarme apte réveiller le conducteur.

Avantageusement ledit capteur est placé dans le boîtier du rétroviseur derrière la glace de celui-ci qui est constituée par un miroir sans tain, l'axe optique de réception dudit capteur étant symétrique à un axe orienté dans le plan vertical médian dudit véhicule, par rapport à un axe orthogonal au dit miroir sans tain.

30 De préférence, on détecte la présence du conducteur à sa place en déterminant le nombre de pixels correspondants dans les trames successives de même nature du signal vidéo pour lesquels un déplacement significatif est détecté et en comparant ce nombre au nombre total de pixels par trame du signal vidéo, afin de déterminer si le rapport entre le

nombre de pixels représentant un déplacement et le nombre total de pixels par trame dépasse un seuil représentatif du passage de l'absence de conducteur à sa place à la présence d'un conducteur à sa place.

- Le procédé peut, dans des modes de réalisation préférés, comprendre en outre une ou plusieurs des caractéristiques suivantes :
- 5 - entre les phases de détection des déplacements horizontaux, afin de cadrer le visage du conducteur, et de détection des déplacements verticaux, afin de cadrer les yeux de celui-ci, on prévoit une phase de cadrage large des yeux en se limitant à une portion du visage cadré englobant les yeux et leur environnement immédiat, par application du rapport anthropométrique entre ladite portion et le visage entier d'une personne ;
 - 10 - simultanément à la phase de détermination des durées de clignement des yeux, on prévoit une phase de détermination des intervalles de temps séparant deux clignements successifs de ceux-ci et on déclenche une alarme renforcée dès que ces intervalles de temps présentent une irrégularité qui dépasse un seuil déterminé ;
 - 15 - on réactualise en continu les données concernant au moins un des paramètres suivants : déplacements horizontaux, déplacements verticaux, durées des clignements des yeux, intervalles entre clignements successifs, afin de perfectionner les approximations des valeurs normales de ces paramètres pour le conducteur effectivement présent et à l'état éveillé ;
 - 20 - les différentes phases successives du procédé sont réalisées au moyen de programmes informatiques successifs portant sur le traitement des valeurs successives des pixels correspondants des trames de même nature du signal vidéo obtenu à partir dudit capteur.

La présente invention a également pour objet un dispositif pour surveiller en continu l'état de vigilance du conducteur d'un véhicule automobile, afin de détecter et prévenir une tendance éventuelle à l'endormissement de celui-ci, qui met en œuvre le procédé susvisé et qui est caractérisé en ce qu'il comprend, en combinaison :

- a) un capteur optoélectronique, qui, en combinaison avec une électronique associée, élabore, en réponse à la réception de rayons lumineux, un signal vidéo à trames de même nature, ou correspondantes, successives, ledit capteur étant solidaire d'un rétroviseur du véhicule automobile et dimensionné et disposé pour recevoir essentiellement l'image du visage du conducteur en place sur son siège et ayant son axe

optique de réception des rayons lumineux dirigé vers la tête du conducteur lorsque le rétroviseur est correctement orienté; et

b) au moins un circuit intégré comportant

- des moyens pour détecter la présence du conducteur à sa place dans le véhicule, et pour
5 élaborer un signal de présence ;
- des moyens, activés par ce signal de présence, pour détecter, à partir d'une analyse des pixels en déplacement entre deux trames successives de même nature dudit signal vidéo, les déplacements horizontaux de dit conducteur, afin de cadrer le visage de celui-ci dans les trames successives de même nature dudit signal vidéo, et pour élaborer
10 un signal de fin de cadrage de visage ;
- des moyens, activés par ledit signal de fin de cadrage du visage, pour détecter, à partir d'une analyse des pixels en déplacement entre deux trames successives de même nature de la portion des trames successives de même nature dudit signal vidéo correspondant au cadrage du visage, les déplacements verticaux dans le visage, ainsi cadré, du conducteur, afin de cadrer les yeux de celui-ci dans ladite portion des trames de ce signal,
15 et pour élaborer un signal de fin de cadrage des yeux du conducteur ;
- des moyens, activés par ledit signal de fin de cadrage des yeux, pour déterminer, à partir d'une analyse des pixels en déplacement entre deux trames successives de même nature de la portion des trames successives de même nature dudit signal vidéo correspondant au cadrage des yeux, les durées successives des clignements des yeux du conducteur ;
20
- des moyens pour comparer ces durées successives des clignements, ainsi déterminées, à un seuil représentatif du passage de l'état éveillé à l'état somnolent du conducteur ; et
- des moyens pour déclencher, lorsque les durées des clignements dépassent ledit seuil,
25 une alarme apte à réveiller le conducteur.

Avantageusement, dans ledit dispositif, ledit capteur est placé dans le boîtier du rétroviseur derrière le miroir de celui-ci, qui est un miroir sans tain, ledit capteur étant porté par une première extrémité d'une première tige traversant, à travers une rotule, un étrier porté par le boîtier du rétroviseur, à l'intérieur de celui-ci, la seconde extrémité de
30 cette tige étant articulée librement, au moyen d'un joint, à la première extrémité d'une seconde tige traversant, à travers une rotule, le boîtier du rétroviseur, tandis que la seconde extrémité de ladite seconde tige est fixée à la carrosserie du véhicule au dessus du pare-brise, de manière que l'axe optique de réception du dit capteur soit symétrique à un axe

orienté dans le plan vertical médian dudit véhicule, par rapport à un axe orthogonal au dit miroir sans tain.

De préférence, lesdits moyens pour détecter la présence du conducteur à sa place et pour élaborer un signal de présence sont constitués par des moyens pour déterminer le nombre de pixels dans les trames successives de même nature dudit signal vidéo pour lesquels un déplacement significatif est détecté, des moyens pour comparer ledit nombre au nombre total de pixels par trame du signal vidéo, afin de déterminer si le rapport entre le nombre de pixels correspondant à un déplacement et le nombre total de pixels par trame dépasse un seuil représentatif du passage de l'état d'absence de conducteur à sa place à l'état de présence d'un conducteur à sa place.

Le dispositif peut, dans des modes de réalisation préférés, comprendre en outre un ou plusieurs des moyens suivants, à savoir :

- des moyens, activés par ledit signal de fin de cadrage du visage, pour sélectionner, dans ladite portion des trames successives dudit signal vidéo correspondant au cadrage du visage, une portion réduite correspondant à un cadrage large, ou grossier, des yeux du conducteur englobant les yeux et leur environnement immédiat par application du rapport anthropométrique entre ledit cadrage large et le visage entier d'une personne et des moyens pour élaborer un signal de fin de cadrage large des yeux, ce signal activant lesdits moyens pour détecter les déplacements verticaux dans le visage du conducteur ;
- des moyens, fonctionnant en parallèle avec lesdits moyens pour déterminer les durées successives des clignements des yeux et donc activés par ledit signal de fin de cadrage des yeux, pour déterminer les intervalles de temps séparant deux clignements successifs et pour déclencher une alarme renforcée dès que ces intervalles de temps présentent une irrégularité qui dépasse un seuil déterminé ;
- des moyens pour réactualiser en continu les données concernant au moins un des paramètres suivants : déplacements horizontaux, déplacements verticaux, durées des clignements des yeux, intervalles entre clignements successifs, afin de perfectionner les approximations des valeurs normales du paramètre impliqué pour le conducteur effectivement présent et à l'état éveillé.

Avantageusement l'ensemble capteur – unité électronique de traitement est réalisé comme décrit et illustré dans les deux demandes de brevet susmentionnées ayant le même inventeur que la présente.

L'invention a également pour objet, à titre de produit industriel nouveau, un rétroviseur de véhicule automobile, caractérisé en ce que son miroir est constitué par une glace sans tain et en ce qu'il comporte, derrière cette glace, un capteur optoélectronique qui coopère avec une unité électronique telle que décrite dans la demande de brevet français N° 96.09420 déposée le 26 juillet 1996 et la demande de brevet international (P.C.T.) PCT/FR97 /01354 déposée le 22 juillet 1997, cette unité étant également disposée à l'intérieur du rétroviseur et étant apte à déclencher un dispositif d'alarme dès que ladite unité détermine que les mouvements verticaux des paupières d'une personne regardant la face avant de ladite glace correspondent à une durée des clignements des yeux qui dépasse un seuil prédéterminé inclus dans l'intervalle temporel compris entre la durée des clignements d'une personne éveillée et celle d'une personne qui somnole.

De préférence ledit rétroviseur porte au moins une diode électroluminescente au moins dans l'infra-rouge qui est activée au moins lorsque la luminosité ambiante devient insuffisante pour éclairer le visage du conducteur, ledit capteur optoélectronique étant sensible, entre autres, aux radiations infra-rouges émises par ladite diode.

Avantageusement, dans le dispositif ainsi que le rétroviseur selon l'invention, le capteur, ladite électronique associée et ledit circuit intégré sont constituées par une puce électronique (chip) disposée à l'intérieur du boîtier du rétroviseur.

On va décrire maintenant un mode de réalisation préféré d'un dispositif selon l'invention, mettant en œuvre le procédé selon l'invention, ainsi que certaines variantes de celui-ci, avec référence aux dessins annexés, sur lesquels :

Les figures 1 et 2 sont des vues, respectivement de côté et par-dessus, illustrant schématiquement la tête d'un conducteur de véhicule automobile et ses axes de vision vers l'avant et vers l'arrière.

La figure 3 illustre schématiquement la disposition classique du miroir d'un rétroviseur intérieur dans un véhicule automobile et les différents axes de vision du conducteur, cette figure correspondant à l'état de la technique.

Les figures 4 et 5 représentent respectivement l'ensemble et les articulations d'un rétroviseur avec le capteur optoélectronique et son électronique associée dans le cadre de l'invention.

La figure 6 illustre le champ du capteur optoélectronique prévu dans le rétroviseur des figures 4 et 5.

Les figures 7 et 8 représentent la manière de cadrer le visage du conducteur en place.

Les figures 9 et 10 représentent la manière de cadrer les yeux du conducteur en place.

5 Les figures 11 et 12 sont relatives à la mesure de la durée des clignements des yeux du conducteur et des intervalles temporels séparent deux clignements successifs.

La figure 13 représente l'ordinogramme des phases successives de fonctionnement.

La figure 14 illustre les avantages de la mise en œuvre, comme capteur, d'un capteur de type MOS.

10 La figure 15, enfin, est une variante de la figure 9, la zone d'observation privilégiée englobant le nez, en plus des yeux.

En se référant tout d'abord aux figures 1 à 6, on va commencer la description détaillée du mode de réalisation préféré de l'invention par celle du dispositif optique et mécanique avec le capteur optoélectronique (micro-caméra vidéo ou capteur MOS avec
15 lentille incorporée) et son ensemble électronique associé, constitué essentiellement par une ou plusieurs puces, qui transforme l'image captée par le capteur en un signal vidéo qui est traité afin de détecter une tendance à l'endormissement du conducteur en place, observé par ledit capteur.

En effet l'invention utilise essentiellement la variation de la durée des clignements
20 des yeux d'une personne lors du passage de l'état éveillé à l'état somnolent ou assoupi de celle-ci : une personne éveillée cligne, à intervalles relativement réguliers, des paupières, et donc des cils, en 100 à 200 ms environ, tandis que la durée des clignements de cette personne à l'état somnolent passe à 500 à 800 ms environ, les intervalles entre clignements augmentant et étant variables.

25 Dans le signal vidéo en provenance du capteur optoélectronique à 50 ou 60 trames correspondantes (de même nature) par seconde, on réalise une détection toutes les 20 ms ou 16,66 ms respectivement, ce qui permet de distinguer facilement des durées de 100 à 200 ms ou de 500 à 800 ms (5 à 10 trames pour l'état éveillé ou au contraire 25 à 40 trames pour l'état somnolent dans le cas de 50 trames de même nature par seconde) et donc
30 distinguer l'état éveillé de l'état somnolent ou assoupi d'une personne.

Pour une utilisation d'une telle distinction dans le cas du conducteur d'un véhicule automobile, il est désirable de visualiser au mieux la face du conducteur, c'est-à-dire de diriger l'axe optique d'entrée ou réception dudit capteur vers le visage de celui-ci. Le moyen

prévu dans le mode de réalisation préféré de l'invention consiste à profiter du fait qu'un conducteur dirige le rétroviseur de son véhicule vers son visage de manière qu'il ait une vue vers l'arrière du véhicule par réflexion sur le miroir du rétroviseur.

On rappelle, avec référence aux figures 1 à 3, le fonctionnement des rétroviseurs classiques logés à l'intérieur d'un véhicule en position centrale, en étant fixés, avec possibilité d'ajustement de l'orientation de leur miroir, sur une portion de la carrosserie à l'intérieur du véhicule.

Les figures schématiques 1 et 2 montrent, vue de côté et de dessus respectivement, la tête *T* d'un conducteur qui peut observer la rue ou route sur laquelle se trouve son véhicule, d'une part, devant lui (flèche 1) et, d'autre part, derrière lui (flèches *2a* et *2b*) grâce au miroir 3 du rétroviseur convenablement orienté. Lesdites flèches 1, *2a*, *2b* représentent le parcours des rayons lumineux, *2b* correspondant au rayon réfléchi sur le miroir 3.

En considérant maintenant la figure schématique 3, qui représente le miroir 3 du rétroviseur, miroir fixé par un bras 4 sur une portion 5 de la carrosserie à l'intérieur du véhicule, avec possibilité d'orientation, on retrouve les axes de visée ou flèches 1, *2a*, *2b* des figures 1 et 2. On peut noter que les axes ou flèches 1 et *2b* sont parallèles et sont dirigés suivant la direction de la rue ou de la route.

Sur cette figure 3, on a également représenté, mais en traits interrompus, l'axe optique 6 perpendiculaire à la face *3a* du miroir 3 d'un rétroviseur intérieur qui divise l'angle formé par les directions *2a* et *2b* en deux moitiés égales (angles *a* et *b* égaux) d'après les lois de la réflexion, et l'axe 7 perpendiculaire à l'axe *2b* et donc parallèle à la portion de support 5, l'angle *c* entre les directions 7 et *3a* étant égal aux angles *b* et *a*.

Ces principes de fonctionnement des rétroviseurs intérieurs étant rappelés, on va maintenant avec référence aux figures 4 et 5, exposer le montage mécanique permettant de diriger effectivement l'axe optique d'entrée du capteur optoélectronique vers le visage du conducteur en place, en profitant du fait que le miroir 3 d'un rétroviseur est orienté par le conducteur en place, lorsque cela n'est pas déjà le cas, pour que l'axe *2a* de visée par le conducteur soit dirigé vers la tête *T* de celui-ci. En effet, si l'axe optique d'entrée du capteur est effectivement dirigé vers la face de conducteur, le signal vidéo produit par celui-ci contiendra les informations nécessaires pour déterminer la durée des clignements des yeux de celui-ci.

Tout d'abord dans le cadre du mode de réalisation préféré de l'invention, le rétroviseur 8 comprend, contrairement au rétroviseurs classiques, une glace sans tain 9 (figure 4) dont la face 9a dirigée vers le conducteur joue le même rôle que la face 3a du miroir 3 d'un rétroviseur classique (figure 3), mais qui permet à un capteur 10 (constitué par une micro-caméra électronique ou un capteur MOS à lentille incorporée), porté par un support 11 (tournant avec le miroir sans tain 9), de recevoir au moins l'image du visage du conducteur en place lorsque le miroir sans tain 9 (avec le rétroviseur 8) est convenablement orienté par le conducteur pour percevoir la rue ou la route derrière lui ou est déjà ainsi orienté (comme c'est le cas pour le miroir classique 3 de la figure 3).

L'articulation mécanique type Cardan, illustrée sur les figures 4 et 5 (cette dernière figure étant une vue plus détaillée d'une portion de la figure 4), permet l'orientation automatique correcte du support 11, avec le capteur 10, par le conducteur lorsqu'il règle son rétroviseur ou lorsque celui-ci est déjà réglé, et donc de la face réceptrice 10a du capteur 10 pour qu'elle reçoive l'image du visage du conducteur en place, son axe optique d'entrée 10b étant dirigé vers la tête du conducteur en place du fait de l'angle entre le miroir 9 et le support 11 du capteur 10.

A cet effet l'articulation pour le support 11 comprend deux tiges 12 et 13 articulées librement entre elles par une rotule 14a (figure 4) ou un manchon 14b (figure 5.). La tige 12 est fixée à une portion 5 de la carrosserie par une de ses extrémités et traverse le boîtier du rétroviseur 8 grâce à la rotule 15 (constituée par une bille et deux calottes sensiblement hémisphériques) avant de pénétrer par son autre extrémité dans le manchon 14b ou être fixée à la rotule 14a, tandis que la tige 13 porte rigidement, à une extrémité, le support 11 du capteur 10 et traverse l'étrier 16 du rétroviseur 8 grâce à une rotule creuse 17 (à bille traversée par un canal dans lequel est engagée la tige 13 et tournant dans deux calottes sensiblement hémisphériques portées par l'étrier 16) avant de rejoindre par son autre extrémité la rotule 14a ou le manchon 14b.

Une telle articulation, qui maintient en permanence un angle approprié entre le miroir 9 et le support 11, permet à la fois l'orientation habituelle du rétroviseur intérieur par le conducteur et l'orientation du support 11 du capteur 10 pour que la face 10a de ce capteur reçoive l'image d'au moins le visage du conducteur en place lorsque le rétroviseur est convenablement orienté.

Le capteur optoélectronique 10 débite par un conducteur 18 dans une unité électronique d'analyse 19 (avantageusement constituée par un boîtier à puce ou puces logé

à l'intérieur du rétroviseur 8) le signal vidéo qu'il élabore à partir de l'image qu'il reçoit sur sa face 10a.

On peut prévoir des diodes électroluminescentes 20 pour émettre, en direction du conducteur en place, lorsque le rétroviseur est correctement orienté, un rayonnement infrarouge apte à éclairer au moins le visage de conducteur en place, lorsque la lumière d'ambiance (y compris celle du tableau de bord) est insuffisante pour le fonctionnement correct du capteur 10, qui dans ce cas doit être sensible au rayonnement infrarouge, et de son unité électronique 19 ; l'excitation, éventuellement progressive, de ces diodes est, par exemple, contrôlée par l'unité électronique 19 grâce à une cellule photoélectrique (non représentée) ou en réponse à des signaux de pixels (dans le signal vidéo) d'intensité insuffisante (comme représenté schématiquement par le conducteur 21).

L'alarme activée, en cas d'endormissement du conducteur, par l'unité électronique 19 est illustrée schématiquement en 22 sur le figure 4, sur laquelle on n'a pas illustré les alimentations du capteur 10, de l'unité électronique 19 et des diodes 20, pour simplifier cette figure.

L'unité 19 pourrait, en variante, être disposée hors du boîtier du rétroviseur.

On va maintenant exposer le traitement, dans l'unité électronique d'analyse 19, du signal vidéo issu du capteur optoélectronique 10 (à micro-caméra électronique ou capteur MOS avec lentille incorporée suivie d'une unité électronique), ce signal vidéo comportant une succession de trames correspondantes (de même nature) à la cadence de 50 ou 60 telles trames par seconde (soit les trames paires ou bien impaires dans le cas d'un signal à deux trames entrelacées par image, soit les trames uniques dans le cas d'un signal à une seule trame par image) ; ce traitement a pour objet de réaliser la surveillance de la vigilance du conducteur en place en déterminant, en temps réel et en continu, la durée des clignements de ses yeux et en déclenchant, en cas de tendance du conducteur à l'endormissement (révélée par la variation de cette durée), un signal d'alarme apte à éveiller celui-ci.

Le procédé et le dispositif, selon la présente invention mettant en œuvre, pour repérer et localiser une zone en mouvement (à savoir successivement le conducteur, son visage et ses yeux, en particulier ses paupières) et déterminer la direction et éventuellement la vitesse de ce mouvement, le procédé et le dispositif selon les demandes de brevet susvisées, dont les descriptions sont incorporées dans la présente description détaillée par référence, il est utile de résumer le processus décrit dans ces demandes de brevet.

Dans ces demandes, le signal vidéo (produit par une caméra vidéo ou autre capteur), qui comprend une succession de trames de même nature (constituées par les trames correspondantes, soit paires, soit impaires, dans le cas d'un système vidéo à deux trames entrelacées par image, soit les trames successives dans le cas d'un système vidéo à

5 trame unique par image), est traité pour successivement

- déduire, des variations de la valeur ou intensité de chaque pixel entre une trame et la trame correspondante antérieure,
 - d'une part, un signal binaire, noté *DP*, dont les deux valeurs possibles sont représentatives, l'une, d'une variation significative de la valeur du pixel et, l'autre,

10 d'une non-variation significative de cette valeur, valeurs notées par exemple «1» et «0» respectivement, et
 - d'autre part, un signal numérique, noté *CO*, à nombre réduit de valeurs possibles, ce signal étant représentatif de la grandeur de cette variation de la valeur du pixel ;
- répartir suivant une matrice, par roulement, des valeurs de ces deux signaux *DP* et *CO*

15 pour une même trame qui défile à travers la matrice ; et
- déduire, de cette répartition matricielle, le déplacement recherché et ses paramètres (localisation, direction et vitesse).

Cette dernière opération de détection du déplacement met en préférence en œuvre, selon ces demandes de brevet précitées,

- 20
- la formation d'histogrammes, suivant deux axes, par exemple O_x et O_y orthogonaux, d'au moins les signaux *DP* et *CO*, répartis matriciellement dans l'opération précédente, et
 - le repérage, dans chacun des histogrammes relatifs à *DP* et *CO*, d'un domaine de variation significative de *CO* avec simultanément $DP = \text{«1»}$.

25 La présente invention, réalise successivement, par mise en œuvre du procédé et dispositif selon les demandes de brevet précitées, dont on vient de résumer le processus,

- dans une phase préliminaire, la détection de la présence d'un conducteur en place ;
- dans une première phase, le cadrage du visage du conducteur dans les trames de même nature, ou correspondantes, successives du signal vidéo ;

30

- dans une deuxième phase, le cadrage des yeux du conducteur à l'intérieur du cadrage du visage ;

- dans une troisième phase, la détermination des durées successives des clignements des yeux du conducteur, et éventuellement la détermination des intervalles de temps séparant deux clignements successifs ;
- dans une quatrième phase, la comparaison des durées des clignements à un certain seuil, avec génération d'un signal d'alarme apte à éveiller le conducteur dès que cette comparaison révèle le dépassement vers le haut de ce seuil par cette durée, et éventuellement la comparaison des variations temporelle des intervalles de temps entre deux clignements successifs à un autre seuil, avec génération d'un signal d'alarme renforcé dès que cette comparaison révèle le dépassement vers le haut de ce dernier seuil.

10

On va décrire maintenant plus en détail la réalisation de chacune de ces cinq phases par le procédé et le dispositif selon l'invention.

La phase préliminaire, qui détecte la présence d'un conducteur en place et amorce la première phase de cadrage du visage, est déclenchée par un contacteur actionné manuellement ou autrement, notamment par mise en œuvre des procédé et dispositif des demandes de brevet précitées ; elle commence effectivement avec le réglage du rétroviseur pour orienter la face avant 9a du miroir sans tain 9 de celui-ci (figure 4) vers le conducteur afin qu'il aperçoive dans ce miroir la rue ou route derrière lui, au cas il y a besoin d'un tel réglage.

20

La figure 6 illustre, entre les directions 23a et 23b, le champ 23 du capteur 10, la tête T du conducteur devant se trouver, du fait du réglage du rétroviseur intérieur 8, tel que décrit avec référence aux figures 4 et 5, à l'intérieur et dans la zone centrale de ce champ conique 23. Ce champ peut être relativement étroit, étant donné que les déplacements de la tête T du conducteur au cours de la conduite sont limités (sauf rares exceptions) ; la limitation du champ améliore la sensibilité du dispositif étant donné que l'image du visage du conducteur, qui est reçue par la face 10a du capteur correctement orienté en même temps que le miroir 9, occupe alors une place relativement importante dans les trames du signal vidéo ; elle est donc représentée par un nombre de pixels qui est une fraction notable du nombre total des pixels par trame.

25

Sur la figure 6 on retrouve les directions ou rayons lumineux 1, 2a et 2b de la figure 3.

30

La mise en place du conducteur est avantageusement détectée par les déplacements de sa tête, en particulier de son visage, pour venir en position de conduite, par mise en

œuvre du procédé et du dispositif selon les deux demandes de brevet précitées qui permettent de détecter les déplacements, comme rappelé brièvement ci-dessus.

En fait l'arrivée du conducteur à sa place et le déplacement de sa tête *T* en résultant sont révélés par le nombre important de pixels du signal vidéo pour lesquels le signal binaire *DP* a la valeur «1» correspondant à une variation significative de la valeur du pixel entre deux trames correspondantes successives et le signal numérique *CO* a une valeur relativement élevée.

Le rapport du nombre de tels pixels (avec *DP* et *CO* ayant les valeurs définies ci-dessus) au nombre total de pixels d'une trame, lors de la mise en place du conducteur, dépend de la dimension du champ de vision du capteur de part et d'autre de la tête *T* en place pour la conduite. En cas de champ de vision étroit (angle réduit entre 23*a* et 23*b* figure 6), on peut considérer par exemple, que si plus de la moitié des pixels «en déplacement» d'une trame ont un *DP* et un *CO* avec les valeurs sus-avancées, il y a mise en place du conducteur. On peut alors considérer un seuil de 50 % entre le nombre de pixels «en déplacement» et le nombre total de pixels d'une trame et dans ce cas la phase préliminaire se termine par la production, lorsque ce seuil est dépassé vers le haut, d'un drapeau «1» de présence qui amorce la suite du traitement du signal vidéo, en commençant par la première phase. Bien entendu le seuil retenu pour le déclenchement du drapeau «1» peut être différent de 50 %, en tenant compte du champ de vision du capteur 10.

En variante, le drapeau «1» de présence amorçant la première phase peut être produit par une commande externe à l'unité électronique 19, mais déclenchant celle-ci, par exemple provoquée par l'actionnement de la clé de contact, le bouclage de la ceinture de sécurité du conducteur ou le fléchissement du siège du conducteur sous son poids.

Lorsque la présence du conducteur a été révélée et le drapeau «1» de présence généré, la première phase de traitement du signal vidéo peut commencer. Elle consiste, comme indiqué précédemment, à cadrer le visage du conducteur dans le signal vidéo en éliminant les portions superflues, en haut, en bas, à droite et à gauche de la tête dans l'image perçue par le détecteur 10.

A cet effet, par mise en œuvre du procédé et du dispositif selon l'invention, ce sont les déplacements horizontaux, c'est-à-dire de la droite vers la gauche et inversement, qui sont détectés, car la tête d'un conducteur a tendance à se déplacer horizontalement plutôt que verticalement, c'est-à-dire de haut en bas et inversement.

On extrait, donc, du flot des données représentées dans les trames correspondantes successives du signal vidéo, un signal de déplacement horizontal, en position, sens et éventuellement vitesse, grâce à la matrice roulante des valeurs de DP et CO , et on l'analyse par sélection suivant deux axes de coordonnées privilégiés, par exemple les axes classiques Ox et Oy des coordonnées cartésiennes, par mise en œuvre des moyens de formation
5 d'histogrammes des demandes de brevet précitées.

La comptabilisation, en fin de trames, des pixels représentatifs d'un déplacement horizontal permet de détecter des pics de déplacement le long des bords du visage, pour lesquels les variations de luminosité, donc de valeur de pixel, sont les plus importantes,
10 aussi bien en projection horizontale suivant Ox qu'en projection verticale suivant Oy par exemple.

Ceci est illustré sur la figure 7 sur laquelle on a représenté les axes Ox et Oy , ainsi que les histogrammes $24x$, suivant Ox , et $24y$, suivant Oy , c'est-à-dire en projection horizontale et verticale respectivement.

15 Les pics $25a$ et $25b$, de l'histogramme $24x$, et $25c$ et $25d$, de l'histogramme $24y$, délimitent, par leur coordonnées respectives $26a$, $26b$, $26c$, $26d$, un cadre limité par les droites Ya , Yb , Xc , Xd qui renferme le visage V du conducteur entouré par les ondulations respectives $27a$, $27b$, $27c$, $27d$ qui illustrent les légers mouvements du conducteur dans les zones de plus grande variation des intensités des pixels, lors de ses mouvements.

20 Le repérage des coordonnées $26a$, $26b$, $26c$ et $26d$, correspondant aux quatre pics $25a$, $25b$, $25c$ et $25d$ des deux histogrammes $24x$ et $24y$, permet donc de mieux définir et cadrer l'emplacement du visage V du conducteur dans la zone Z et d'éliminer, pour la suite du traitement du signal vidéo, les portions supérieure, inférieure, de droite et de gauche par rapport au cadre Xc , Xd , Ya , Yb , comme illustré sur la figure 8 par des zones hachurées
25 encadrant le visage V , ce qui permet d'accroître la précision, et éventuellement la cadence, de l'analyse portant sur la zone centrale Z , non hachurée, encadrée par les droites Xc , Xd , Ya , Yb et contenant le visage V .

Cette opération de cadrage du visage entier est renouvelée à intervalles réguliers, par exemple toutes les dix trames du signal vidéo, et les valeurs moyennes (au cours du
30 temps) des coordonnées $26a$, $26b$, $26c$, $26d$, sont déterminées, en redéfinissant le cadre, légèrement variable, mais relativement stable, Xc , Xd , Ya , Yb autour du visage V . On constate donc que la position dudit cadre (avec la zone limitée pour l'analyse ultérieure) est très robuste, c'est-à-dire stable au cours du temps.

Un nouveau drapeau «1» de visage cadré est produit après établissement du cadrage du visage V du conducteur.

La production de ce drapeau déclenche la deuxième phase, qui consiste à réduire encore plus le cadre du traitement, à savoir à celui des yeux du conducteur.

5 Cette deuxième phase comporte, de préférence, une opération préliminaire consistant à utiliser, dans l'unité électronique 19, le rapport anthropométrique habituel entre la zone des yeux et l'ensemble du visage chez un être humain, notamment dans le sens vertical, la zone des yeux occupant seulement une portion limitée du visage entier.

10 L'unité électronique 19 détermine alors, dans cette opération préliminaire, par ratio un cadre Z' plus limité, incluant les yeux U du conducteur, dans le cadre précédent Z du visage V , limité par Ya, Yb, Xc, Xd , ce cadre Z' étant, comme illustré sur la figure 9 défini par les droites $Y'a, Y'b, X'c$ et $X'd$ à l'intérieur du cadre Ya, Yb, Xc, Xd (zone Z).

15 On élimine ainsi les zones hachurées externes (simples hachures) sur la figure 9 pour ne conserver que le cadre Z' , ce qui facilite le cadrage définitif des yeux dans la deuxième phase et augmente sa précision et la vitesse de sa détermination.

Après la fin de cette opération préliminaire si elle existe, ce qui génère un drapeau «1» de cadrage grossier des yeux, ou directement après la première phase de traitement, c'est-à-dire respectivement en réponse à l'apparition du drapeau «1» de cadrage grossier des yeux ou du drapeau «1» de visage cadré respectivement, l'unité électronique 19
20 effectue la deuxième phase de cadrage effectif plus serré des yeux du conducteur en détectant, dans la matrice des DP et CO , les emplacements de pixels pour lesquels $DP = 1$ et CO présente une valeur élevée, notamment pour des déplacements dans le sens vertical du fait que les paupières clignent de haut en bas et inversement.

25 Lorsque le nombre de tels emplacements de pixels atteint un certain seuil dans le cadre $Y'a, Y'b, X'c, X'd$ (zone Z') dans le cas où l'opération préliminaire est prévue ou dans le cadre Ya, Yb, Xc, Xd (zone Z) en l'absence d'une telle opération préliminaire, ce seuil étant par exemple de 20 % par rapport au nombre total de pixels dans le cadre $Y'a, Y'b, X'c, X'd$ dans le premier cas et de 10 % par rapport au nombre total de pixels dans le cadre Ya, Yb, Xc, Xd dans le second cas, un drapeau «1» de cadrage fin des yeux est généré ; ce
30 drapeau indique en fait que les paupières du conducteur sont actives, car il est provoqué par les clignements des yeux du conducteur ; mouvements dans le sens vertical repérés de la même manière que les déplacements horizontaux du visage du conducteur dans la première phase.

Sur la figure 10 on a illustré le cadre éventuel $Y'a, Y'b, X'c, X'd$, définissent la zone Z' de cadrage grossier des yeux du conducteur, ainsi que les histogrammes $28x$ selon l'axe Ox et $28y$ suivant l'axe Oy des déplacements verticaux des paupières du conducteur, c'est-à-dire des pixels de la matrice révélant, par leur DP et leur CO , de tels déplacements. Ces

5 histogrammes $28x$ et $28y$, qui correspondent aux histogrammes $24x$ et $24y$ des déplacements horizontaux du visage du conducteur, illustrés sur la figure 7, déterminent, par leurs pics $29a, 29b, 29c, 29d$, des droites horizontales $X'c$ et $X'd$ et des droites verticales $Y'a$ et $Y'b$ définissant, à l'intérieur de la zone Z' , une zone Z'' qui encadre les yeux du conducteur dont les déplacements des bords sont indiqués en $30a$ et $30b$ pour un

10 œil et $30c$ et $30d$ pour l'autre œil.

La position du cadre $Y'a, Y'b, X'c, X'd$ est réactualisée par détermination des valeurs moyennes au cours du temps, par exemple toutes les dix trames, des coordonnées des pics $29a, 29b, 29c, 29d$ et, à partir de la production du drapeau «1» de cadrage fin des yeux, ce sont seulement les pixels compris dans le cadre limité de la zone Z'' qui sont

15 traités dans la troisième phase déclenchée par ce drapeau (la zone Z'' étant figurée en blanc sur la figure 9).

Dans cette troisième phase sont déterminées les durées des clignements des yeux, et éventuellement les intervalles de temps séparant deux clignements successifs, en perfectionnant l'analyse des déplacements verticaux des paupières dans la zone Z'' par traitement

20 dans l'unité électronique 19 des portions des trames successives du signal vidéo correspondant à cette zone Z'' , ce qui permet une grande précision.

Sur la figure 11 on a illustré dans un système de coordonnées suivant trois directions orthogonales entre elles, à savoir OQ sur laquelle on a porté CO , c'est-à-dire les intensités de la variation de la valeur de pixel, correspondant au mouvement vertical des

25 paupières, Ot sur laquelle on a porté les intervalles de temps entre deux clignements successifs et Oz sur laquelle on a porté les durées des clignements, donc trois paramètres différents permettant de déterminer le passage de l'état éveillé à l'état endormi du conducteur. Deux clignements successifs C_1 et C_2 sont représentés sur la figure 11.

La figure 12 illustre par la courbe C , sur la portion (a), la variation, dans le temps

30 suivant Ot du nombre de pixels par trame en mouvement vertical significatif (pour lesquels $DP = 1$ et CO a une valeur relativement importante), les pics successifs P_1, P_2, P_3 du nombre de pixels en mouvement correspondant à des clignements.

Les trames correspondantes successives relatives à la courbe C sont représentées, schématiquement et en partie, sur la portion (b) de la figure 12, par des traits verticaux, tels que 31, dont les pics P_1, P_2, P_3 sont encadrés par des rectangles R_1, R_2, R_3 respectivement, les deux portions (a) et (b) de la figure 12 étant disposées, l'une sous l'autre, en synchronisme temporel. Sur cette figure 12 on a représenté enfin les durées des clignements (5,6,5) et les intervalles de temps (14, 17) entre clignements successifs, en nombre de trames, valeurs qui correspondent à l'état éveillé du conducteur.

L'unité électronique 19, dans cette troisième phase, calcule les durées successives des clignements des yeux et les intervalles de temps successifs entre deux clignements consécutifs et fait une analyse statistique bi-dimensionnelle entre les durées successives des clignements et les intervalles entre clignements. Elle établit si les durées des clignements dépassent un certain seuil, par exemple 350 ms, et dans ce cas déclenchent un drapeau «1» de seuil de clignement dépassé et éventuellement si les intervalles de temps entre deux clignements successifs sont relativement constants ou au contraire significativement variables dans le temps, et dans le second cas déclenchent un drapeau «1» d'intervalles entre clignements variables.

Le premier drapeau sert à déclencher une alarme, sonore par exemple, apte à réveiller le conducteur, tandis que le second drapeau renforce l'alarme, par exemple en augmentant le niveau sonore.

L'ordinogramme annexé à titre de planche 6 (figure 13) résume les différentes phases successives.

Le dialogue avec l'extérieur est réalisé, de préférence en mode série (CAN – VAN).

L'ensemble du capteur, de l'électronique associée et du processeur ou calculateur peut-être avantageusement intégré dans une puce électronique (chip) logée dans le rétroviseur interne du véhicule.

Le rétroviseur des figures 4 et 5 convient aussi bien pour un conducteur occupant le siège gauche que le siège droit, pour les pays à conduite à droite, et peut éventuellement être un rétroviseur extérieur, notamment du côté du conducteur.

Il est particulièrement intéressant d'utiliser un capteur de type MOS, qui permet une détermination de la valeur de pixel, position par position de pixel, sans être obligé, comme dans le cas d'un capteur CCD d'extraire les valeurs de pixels ligne par lignes et position par position dans chaque ligne.

Comme représenté sur la figure 14, il est alors possible de réaliser une sélection variable des positions de pixels : au lieu (a) d'examiner toutes les positions pp de pixels sur la totalité de l'image (grand nombre de traitements), on peut (b) examiner seulement certains pixels maillés PP formant un réseau régulier représentant la globalité de l'image du visage du conducteur et son environnement immédiat (effet de zoom) ; enfin on peut (c) sélectionner une zone particulière ZP, à savoir celle des yeux en traitant seulement les pixels de cette zone. (puissance de traitement constante)

Sur la figure 15, qui est une variante de la figure 9, dont elle reprend les références, on a prévu de sélectionner pour la phase finale de surveillance du conducteur, non seulement la région des yeux (comme le cas de la figure 9), mais également des narines n du nez N, l'observation des déplacements du contour ou taches sombres des narines permettent d'améliorer le maintien de la zone d'observation incluant les yeux.

Comme il va de soi, l'invention n'est pas limitée au mode de réalisation préféré décrit et illustré, ni à ses variantes mentionnées ci-dessus ; l'invention englobe au contraire les modifications, variantes et perfectionnement entrant dans le cadre des définitions de l'invention données dans le préambule et les revendications jointes.

REVENDICATIONS

1. Procédé pour surveiller en continu l'état de vigilance du conducteur d'un véhicule automobile, afin de détecter et prévenir une tendance éventuelle à l'endormissement de celui-ci,
- 5 qui consiste
- à produire un signal vidéo représentatif, en temps réel, des images successives d'au moins le visage du conducteur ;
 - à traiter ce signal, successivement et en continu, pour
- 10
- détecter, dans ce signal, la portion correspondant effectivement à l'image de la tête du conducteur,
 - déterminer la valeur d'un paramètre relatif au clignement des paupières, qui se modifie notablement lors du passage de l'état éveillé à l'état somnolent du conducteur de part et d'autre d'un seuil, et
- 15
- repérer, en temps réel, le franchissement, par la valeur de ce paramètre, de ce seuil représentatif du passage de l'état éveillé à l'état somnolent du conducteur ; et
 - à déclencher, en réponse au franchissement de ce seuil, une alarme apte à réveiller le conducteur ;
- 20 et qui est caractérisé en ce que
- d'une part, le signal vidéo est produit en utilisant un capteur optoélectronique solidaire d'un rétroviseur du véhicule automobile, dimensionné et disposé pour recevoir essentiellement l'image du visage du conducteur en place sur son siège et ayant son axe optique de réception des rayons lumineux dirigé vers la tête du
- 25
- conducteur lorsque le rétroviseur est correctement orienté ; et
 - d'autre part, le traitement dudit signal vidéo consiste, après avoir détecté la présence du conducteur à sa place, à, successivement et en continu ,
- 30
- détecter, à partir d'une analyse des pixels en déplacement entre deux trames successives de même nature dudit signal vidéo, les déplacements horizontaux du conducteur, afin de cadrer le visage de celui-ci dans les trames correspondantes successives du signal vidéo,

- détecter, à partir d'une analyse des pixels en déplacement entre deux trames successives de même nature dudit signal vidéo, les déplacements verticaux dans le visage, ainsi cadré, du conducteur, afin de cadrer les yeux de celui-ci,
 - déterminer, à partir d'une analyse des pixels en déplacement entre deux trames successives de même nature dudit signal vidéo, les durées successives des clignements des yeux, ainsi cadrés, de celui-ci, ces durées constituant le dit paramètre,
 - comparer ces durées successives des clignements, ainsi déterminées, à un seuil représentatif du passage de l'état éveillé à l'état somnolent du conducteur, et
 - déclencher, lorsque les durées de clignement dépassent vers le haut le dit seuil, une alarme apte réveiller le conducteur.
2. Procédé selon la revendication 1, caractérisé en ce que ledit capteur est placé dans le boîtier du rétroviseur derrière la glace de celui-ci qui est constituée par un miroir sans tain, l'axe optique de réception (2a) dudit capteur étant symétrique à un axe (2b) orienté dans le plan vertical médian dudit véhicule, par rapport à un axe (6) orthogonal au dit miroir sans tain.
3. Procédé selon la revendication 1 ou 2, caractérisé en ce qu'on détecte la présence du conducteur à sa place en déterminant le nombre de pixels correspondants dans les trames successives de même nature du signal vidéo pour lesquels un déplacement significatif est détecté et en comparant ce nombre au nombre total de pixels par trame du signal vidéo, afin de déterminer si le rapport entre le nombre de pixels représentant un déplacement et le nombre total de pixels par trame dépasse un seuil représentatif du passage de l'absence de conducteur à sa place à la présence d'un conducteur à sa place.
4. Procédé selon la revendication 1, 2, ou 3 caractérisé en ce qu'entre les phases de détection des déplacements horizontaux, afin de cadrer le visage du conducteur, et de détection des déplacements verticaux, afin de cadrer les yeux de celui-ci, on prévoit une phase de cadrage large des yeux en se limitant à une portion du visage cadré englobant les yeux et leur environnement immédiat, par application du rapport anthropométrique entre ladite portion et le visage entier d'une personne.
5. Procédé selon l'une quelconque des revendications précédentes, caractérisé en ce, simultanément à la phase de détermination des durées des clignements des yeux, on prévoit une phase de détermination des intervalles de temps séparant deux clignements

successifs de ceux-ci et on déclenche une alarme renforcée dès que ces intervalles de temps présentent une irrégularité qui dépasse un seuil déterminé.

6. Procédé selon l'une quelconque des revendications précédentes, caractérisé en ce qu'on réactualise en continu les données concernant au moins un des paramètres suivants :
 - 5 déplacements horizontaux, déplacements verticaux, durées des clignements des yeux, intervalles entre clignements successifs, afin de perfectionner les approximations des valeurs normales de ces paramètres pour le conducteur effectivement présent et à l'état éveillé.
7. Procédé selon l'une quelconque des revendications précédentes, caractérisé en ce que
10 les différentes phases successives du procédé sont réalisées au moyen de programmes informatiques successifs portant sur le traitement des valeurs successives des pixels correspondants des trames de même nature du signal vidéo obtenu à partir dudit capteur.
8. Dispositif pour surveiller en continu l'état de vigilance du conducteur d'un véhicule
15 automobile, afin de détecter et prévenir une tendance éventuelle à l'endormissement de celui-ci, qui met en œuvre le procédé selon l'une quelconque des revendications 1 à 7 et qui est caractérisé en ce qu'il comprend, en combinaison :
 - a) un capteur optoélectronique (10), qui, en combinaison avec une électronique associée (19), élabore, en réponse à la réception de rayons lumineux, un signal vidéo à trames de
20 même nature, ou correspondantes, successives, ledit capteur étant solidaire d'un rétroviseur (8) du véhicule automobile et dimensionné et disposé pour recevoir essentiellement l'image du visage du conducteur en place sur son siège et ayant son axe optique (10b) de réception des rayons lumineux dirigé vers la tête (T) du conducteur lorsque le rétroviseur est correctement orienté ; *et*
 - 25 b) au moins d'un circuit intégré comportant
 - des moyens pour détecter la présence du conducteur à sa place dans le véhicule, et pour élaborer un signal de présence ;
 - des moyens, activés par ce signal de présence, pour détecter, à partir d'une analyse des pixels en déplacement entre deux trames successives de même nature dudit
30 signal vidéo, les déplacements horizontaux de dit conducteur, afin de cadrer le visage (V) de celui-ci dans les trames successives de même nature dudit signal vidéo, et pour élaborer un signal de fin de cadrage de visage ;

- des moyens, activés par ledit signal de fin de cadrage du visage, pour détecter, à partir d'une analyse des pixels en déplacement entre deux trames successives de même nature de la portion des trames successives de même nature dudit signal vidéo correspondant au cadrage du visage, les déplacements verticaux dans le visage, ainsi cadré, du conducteur, afin de cadrer les yeux (U) de celui-ci dans ladite portion des trames de ce signal, et pour élaborer un signal de fin de cadrage des yeux du conducteur ;
 - des moyens, activés par ledit signal de fin de cadrage des yeux, pour déterminer, à partir d'une analyse des pixels en déplacement entre deux trames successives de même nature de la portion des trames successives de même nature dudit signal vidéo correspondant au cadrage des yeux, les durées successives des clignements des yeux du conducteur ;
 - des moyens pour comparer ces durées successives des clignements, ainsi déterminées, à un seuil représentatif du passage de l'état éveillé à l'état somnolent du conducteur ; et
 - des moyens pour déclencher, lorsque les durées des clignements dépassent ledit seuil, une alarme (22) apte à réveiller le conducteur.
9. Dispositif selon la revendication 8, caractérisé en ce que ledit capteur (10) est placé dans le boîtier du rétroviseur (8) derrière le miroir de celui-ci, qui est un miroir (9) sans tain, ledit capteur (10) étant porté par une première extrémité d'une première tige (13) traversant, à travers une rotule (17), un étrier (16) porté par le boîtier du rétroviseur (8), à l'intérieur de celui-ci, la seconde extrémité de cette tige (13) étant articulée librement, au moyen d'un joint (14a,14b), à la première extrémité d'une seconde tige (12) traversant, à travers une rotule (15), le boîtier du rétroviseur (8), tandis que la seconde extrémité de ladite seconde tige (12) est fixée à la carrosserie du véhicule (en 5) au dessus du pare-brise, de manière que l'axe optique de réception (2a) du dit capteur soit symétrique à un axe (2b) orienté dans le plan vertical médian dudit véhicule, par rapport à un axe orthogonal (6) au dit miroir sans tain.
10. Dispositif selon la revendication 8 ou 9, caractérisé en ce que lesdits moyens pour détecter la présence du conducteur à sa place et pour élaborer un signal de présence sont constitués par des moyens pour déterminer le nombre de pixels dans les trames successives de même nature dudit signal vidéo pour lesquels un déplacement significatif est détecté, des moyens pour comparer ledit nombre au nombre total de

pixels par trame du signal vidéo, afin de déterminer si le rapport entre le nombre de pixels correspondant à un déplacement et le nombre total de pixels par trame dépasse un seuil représentatif du passage de l'état d'absence de conducteur à sa place à l'état de présence d'un conducteur à sa place.

- 5 11. Dispositif selon la revendication 8, 9 ou 10, caractérisé en ce qu'il comprend en outre des moyens, activés par ledit signal de fin de cadrage du visage, pour sélectionner, dans ladite portion des trames successives dudit signal vidéo correspondant au cadrage du visage, une portion réduite correspondant à un cadrage large, ou grossier, des yeux du conducteur englobant les yeux et leur environnement immédiat par application du rapport anthropométrique entre ledit cadrage large et le visage entier d'une personne et
- 10 rapport anthropométrique entre ledit cadrage large et le visage entier d'une personne et des moyens pour élaborer un signal de fin de cadrage large des yeux, ce signal activant lesdits moyens pour détecter les déplacements verticaux dans le visage du conducteur.
12. Dispositif selon l'une quelconque des revendications 8 à 11, caractérisé en ce qu'il comporte des moyens, fonctionnant en parallèle avec lesdits moyens pour déterminer
- 15 les durées successives des clignements des yeux et donc activés par ledit signal de fin de cadrage des yeux, pour déterminer les intervalles de temps séparant deux clignements successifs et pour déclencher une alarme renforcée dès que ces intervalles de temps présentent une irrégularité qui dépasse un seuil déterminé.
13. Dispositif selon l'une quelconque des revendications 8 à 12, caractérisé en ce qu'il
- 20 comporte des moyens pour réactualiser en continu les données concernant au moins un des paramètres suivants : déplacements horizontaux, déplacements verticaux, durées des clignements des yeux, intervalles entre clignements successifs, afin de perfectionner les approximations des valeurs normales du paramètre impliqué pour le conducteur effectivement présent et à l'état éveillé.
- 25 14. Dispositif selon l'une quelconque des revendications 8 à 13, caractérisé en ce que ledit ensemble capteur opto-électronique(10) – unité électronique (19) produit un signal vidéo comportant une succession de trames correspondantes de même nature à succession de lignes constituées par une succession de pixels et traite le dit signal video pour successivement :
- 30 - déduire, des variations de la valeur ou intensité de chaque pixel entre une trame et la trame correspondante antérieure,

- d'une part, un signal binaire, noté DP, dont les deux valeurs possibles sont représentatives, l'une, d'une variation significative de la valeur du pixel et, l'autre, d'une non-variation significative de cette valeur, et
 - d'autre part, un signal numérique, noté CO, à nombre réduit de valeurs possibles, ce signal étant représentatif de la grandeur de cette variation de la valeur du pixel ;
- 5 - répartir suivant une matrice, par roulement, des valeurs de ces deux signaux DP et CO pour une même trame qui défile à travers la matrice ; et
- déduire, de cette répartition matricielle, le déplacement recherché et ses paramètres de localisation et de direction.
- 10 15. Dispositif selon l'une quelconque des revendications 8 à 14, caractérisé en ce que ledit capteur (10), ladite électronique associée (19) et ledit circuit intégré sont constituées par une puce électronique (chip) disposée à l'intérieur du boîtier du rétroviseur (8).
16. Rétroviseur de véhicule automobile, caractérisé en ce que son miroir est constitué par une glace sans tain (9) et en ce qu'il comporte, derrière cette glace, un capteur opto-
- 15 électronique (10) qui coopère avec une unité électronique (19), produit un signal vidéo comportant une succession de trames correspondantes de même nature à succession de lignes constitué par une succession de pixels et traite le dit signal video pour successivement :
- déduire, des variations de la valeur ou intensité de chaque pixel entre une trame et la
- 20 trame correspondante antérieure,
- d'une part, un signal binaire, noté DP, dont les deux valeurs possibles sont représentatives, l'une, d'une variation significative de la valeur du pixel et, l'autre, d'une non-variation significative de cette valeur, et
 - d'autre part, un signal numérique, noté CO, à nombre réduit de valeurs possibles, ce
- 25 signal étant représentatif de la grandeur de cette variation de la valeur du pixel ;
- répartir suivant une matrice, par roulement, des valeurs de ces deux signaux DP et CO pour une même trame qui défile à travers la matrice ;
- déduire, de cette répartition matricielle, le déplacement recherché et ses paramètres de localisation et de direction ; et
- 30 - déclencher un dispositif d'alarme (22) dès que ladite unité détermine que les mouvements verticaux des paupières d'une personne regardant la face avant (9a) de ladite glace correspondent à une durée des clignements des yeux qui dépasse un seuil

prédéterminé inclus dans l'intervalle temporel compris entre la durée des clignements d'une personne éveillée et celle d'une personne qui somnole..

- 5 17. Rétroviseur de véhicule automobile selon la revendication 16, caractérisé en ce que ledit capteur (10), ladite électronique associée (19) et ledit circuit intégré sont constituées par une puce électronique (chip) disposée à l'intérieur du boîtier du rétroviseur (8).
- 10 18. Rétroviseur de véhicule automobile selon la revendication 16 ou 17, caractérisé en ce qu'il porte en outre au moins une diode (20) électroluminescente au moins dans l'infra-rouge qui est activée au moins lorsque la luminosité ambiante devient insuffisante pour éclairer le visage du conducteur et en ce que ledit capteur optoélectronique (10) est sensible entre autres, aux radiations infra-rouges émises par ladite diode.

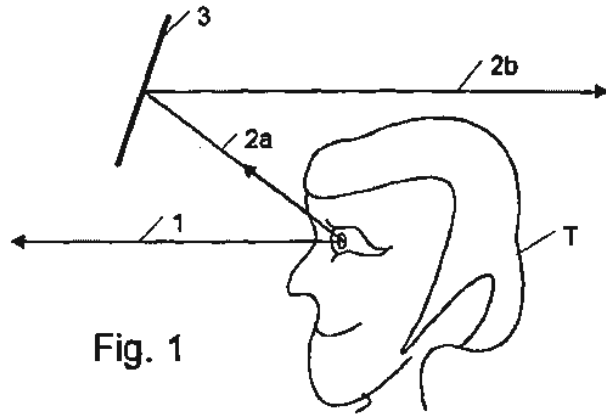

Fig. 1

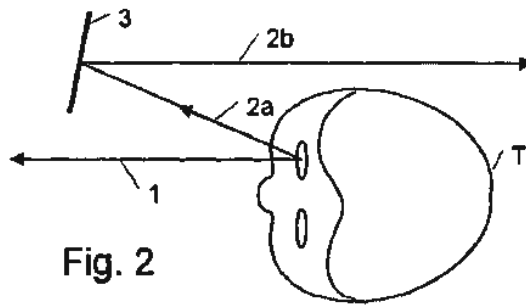

Fig. 2

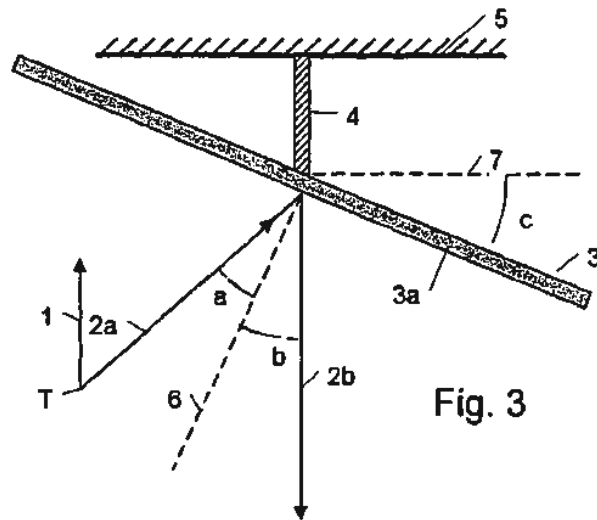

Fig. 3

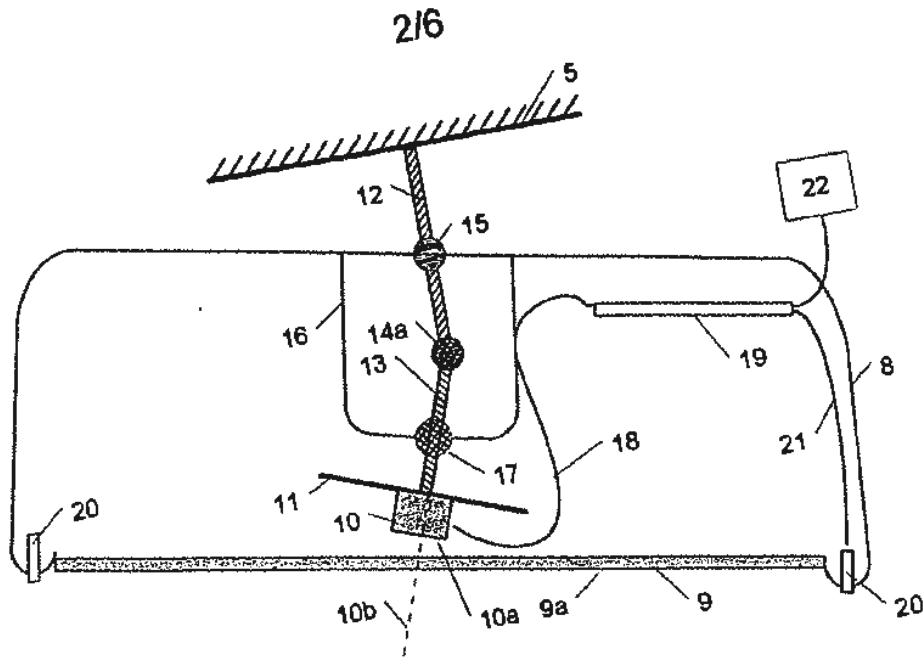

Fig. 4

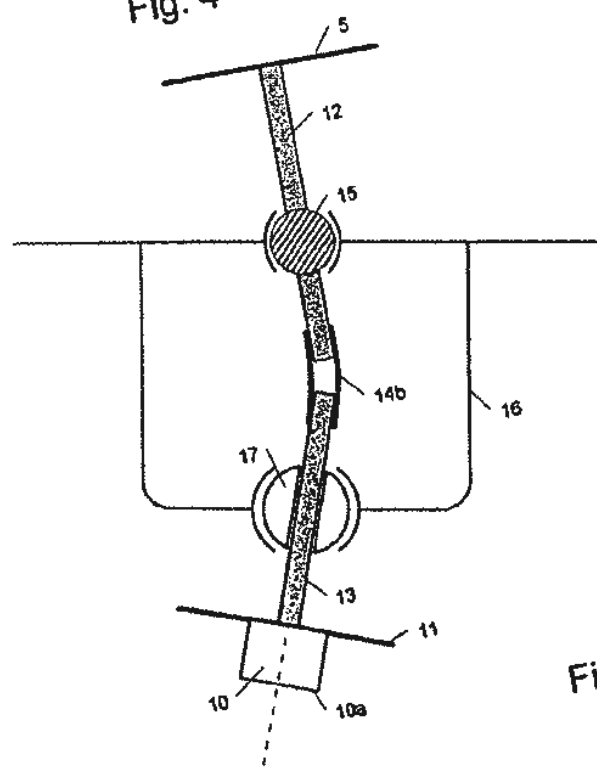

Fig. 5

3/6

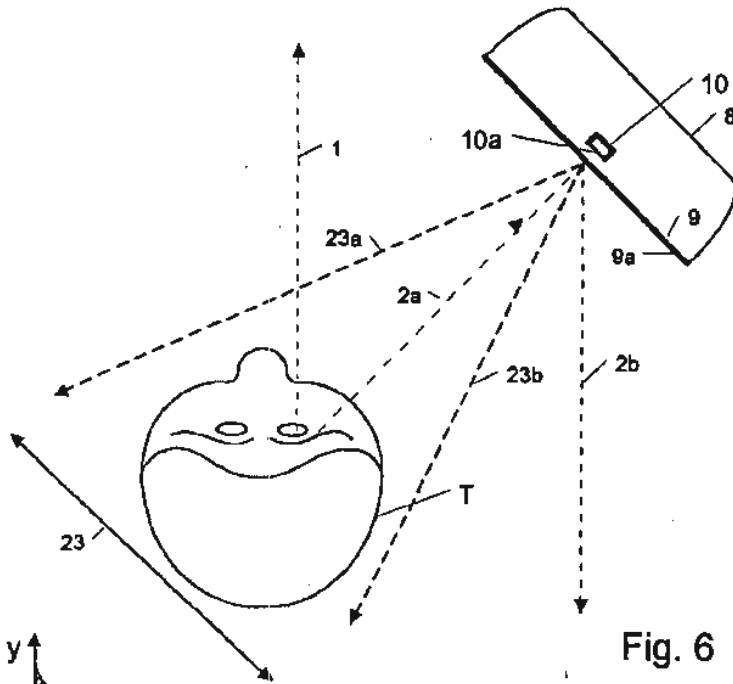

Fig. 6

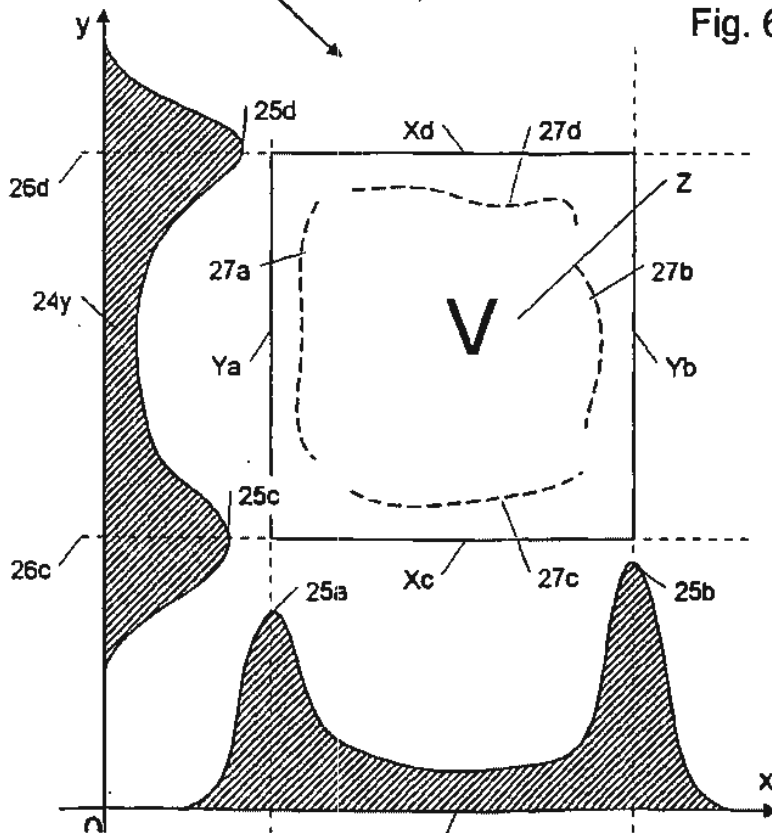

Fig. 7

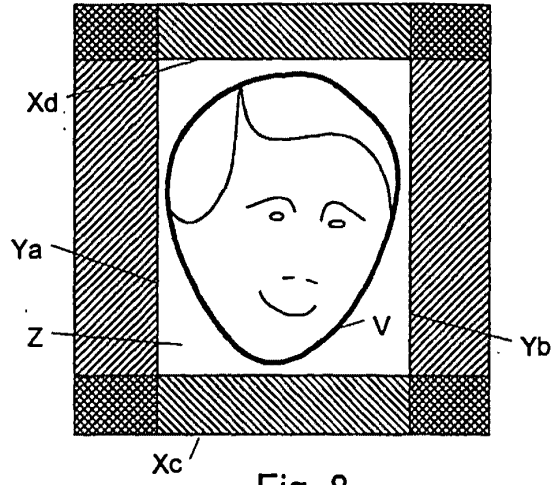

Fig. 8

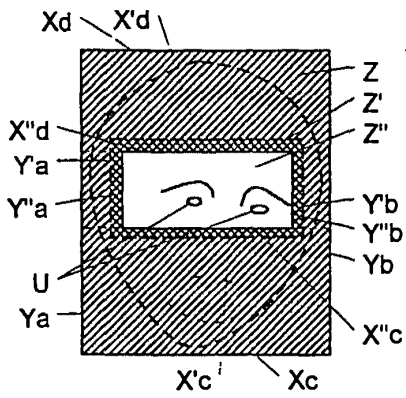

Fig. 9

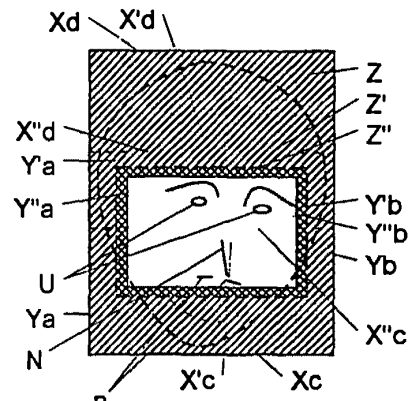

Fig. 15

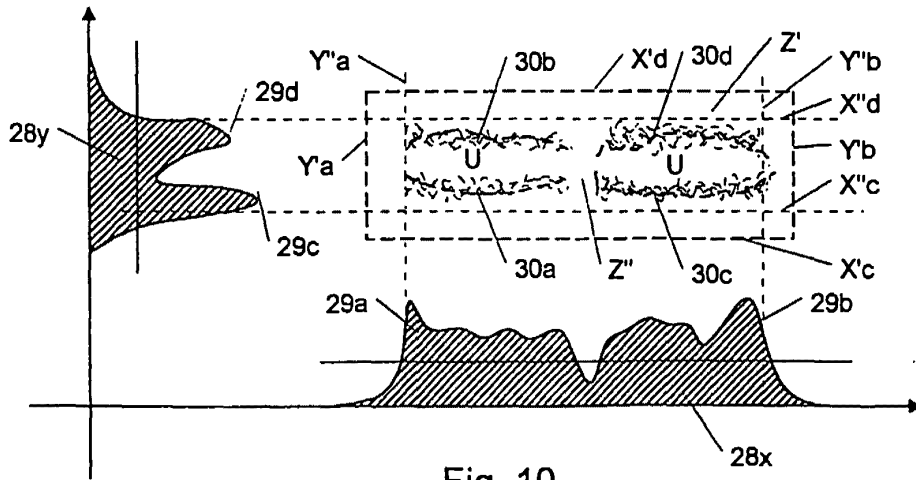

Fig. 10

5/6

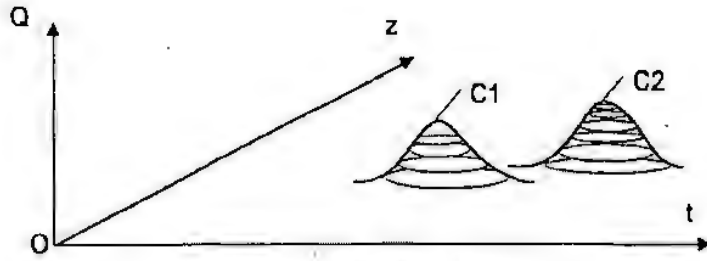

Fig. 11

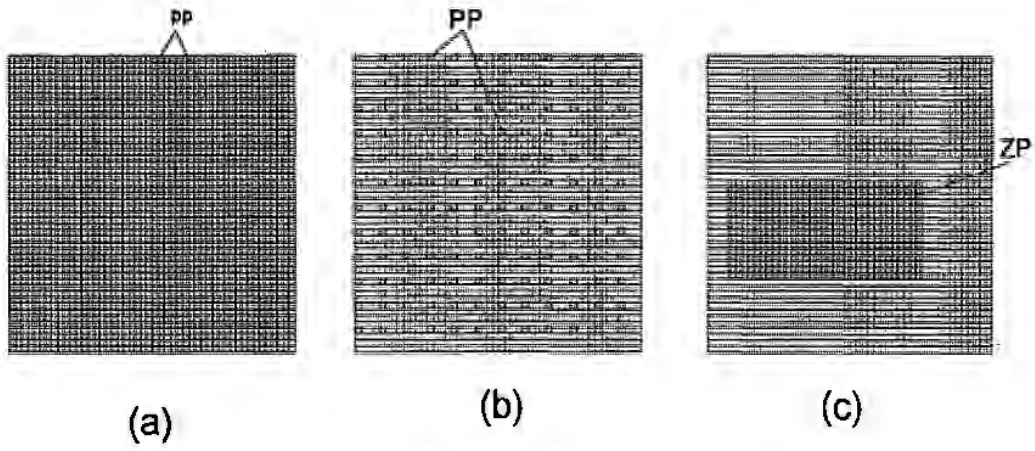

Fig. 14

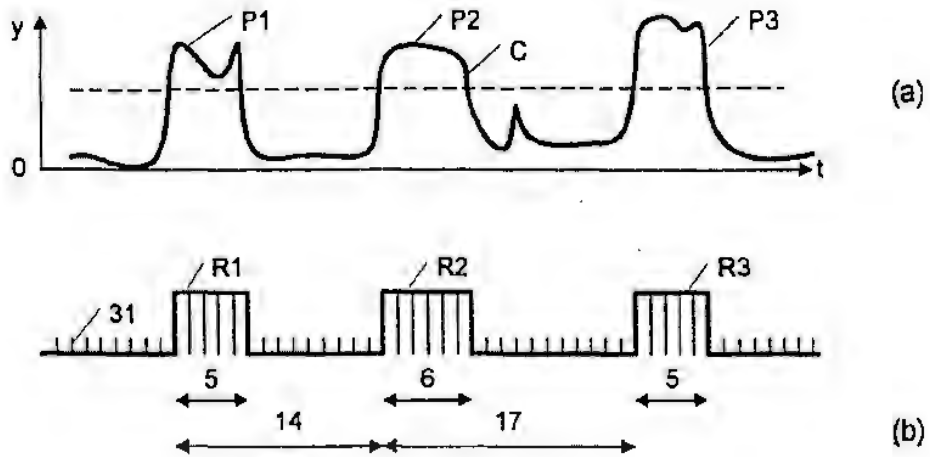

Fig. 12

ORGANIGRAMME DE L'INVENTION

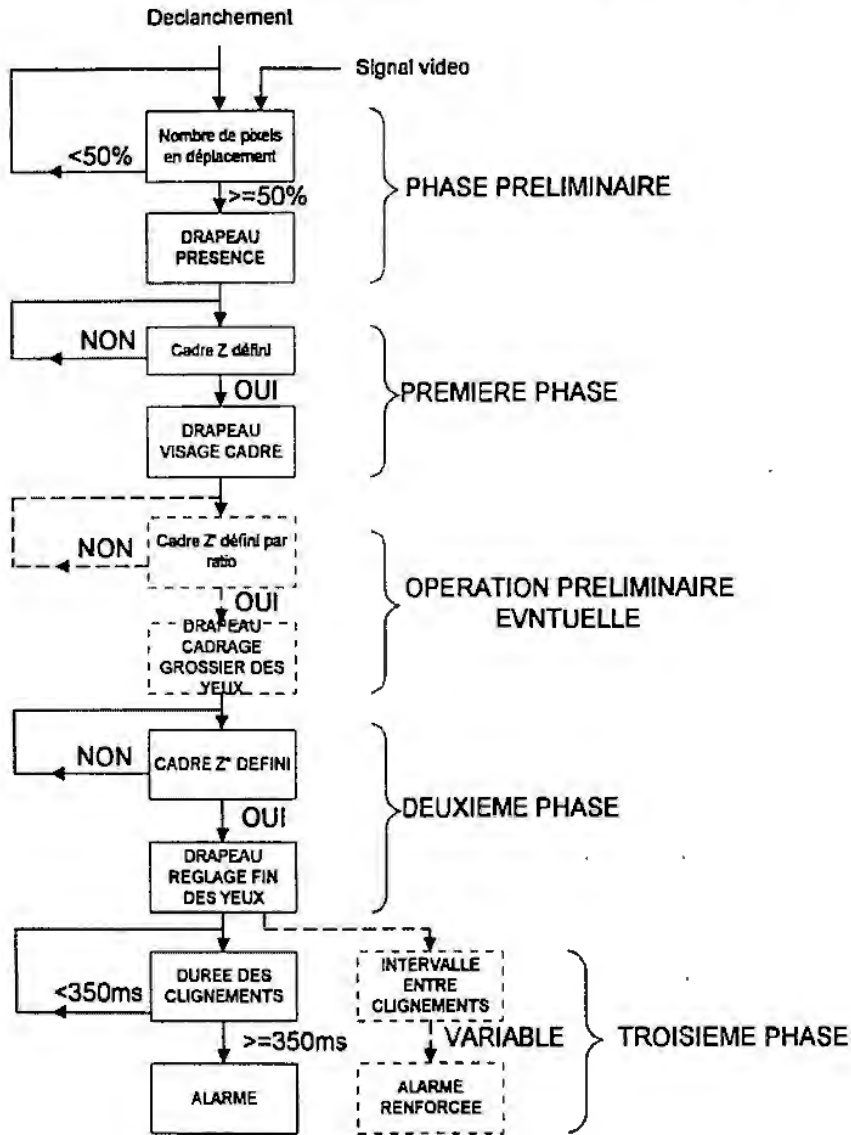

Fig. 13

INTERNATIONAL SEARCH REPORT

Intern. Application No
PCT/FR 99/00060

A. CLASSIFICATION OF SUBJECT MATTER IPC 6 G08B21/00		
According to International Patent Classification (IPC) or to both national classification and IPC		
B. FIELDS SEARCHED		
Minimum documentation searched (classification system followed by classification symbols) IPC 6 G08B		
Documentation searched other than minimum documentation to the extent that such documents are included in the fields searched		
Electronic data base consulted during the international search (name of data base and, where practical, search terms used)		
C. DOCUMENTS CONSIDERED TO BE RELEVANT		
Category*	Citation of document, with indication, where appropriate, of the relevant passages	Relevant to claim No.
Y	DE 197 15 519 A (MITSUBISHI) 6 November 1997 see the whole document	1-18
Y	WO 97 01246 A (STEED VAN P.) 9 January 1997 see abstract	1-18
A	UENO H ET AL: "DEVELOPMENT OF DROWSINESS DETECTION SYSTEM" PROCEEDINGS OF THE VEHICLE NAVIGATION AND INFORMATION SYSTEMS CONFERENCE, YOKOHAMA, AUG. 31 - SEPT. 2, 1994, 31 August 1994, pages 15-20, XP000641294 INSTITUTE OF ELECTRICAL AND ELECTRONICS ENGINEERS	1-18
<input type="checkbox"/> Further documents are listed in the continuation of box C.		
<input checked="" type="checkbox"/> Patent family members are listed in annex.		
* Special categories of cited documents :		
"A" document defining the general state of the art which is not considered to be of particular relevance "E" earlier document but published on or after the international filing date "L" document which may throw doubts on priority claim(s) or which is cited to establish the publication date of another citation or other special reason (as specified) "O" document referring to an oral disclosure, use, exhibition or other means "P" document published prior to the international filing date but later than the priority date claimed "T" later document published after the international filing date or priority date and not in conflict with the application but cited to understand the principle or theory underlying the invention "X" document of particular relevance; the claimed invention cannot be considered novel or cannot be considered to involve an inventive step when the document is taken alone "Y" document of particular relevance; the claimed invention cannot be considered to involve an inventive step when the document is combined with one or more other such documents, such combination being obvious to a person skilled in the art. "S" document member of the same patent family		
Date of the actual completion of the international search:		Date of mailing of the international search report
19 April 1999		23/04/1999
Name and mailing address of the ISA European Patent Office, P.O. 5818 Patentstein 2 NL - 2280 HV Rijswijk Tel. (+31-70) 340-2040, Tx. 31 651 epo nl Fax: (+31-70) 340-3016		Authorized officer Sgura, S

INTERNATIONAL SEARCH REPORT

Information on patent family members

International Application No
PCT/FR 99/00060

Patent document cited in search report	Publication date	Patent family member(s)	Publication date
DE 19715519 A	06-11-1997	JP 9277849 A FR 2747346 A US 5786765 A	28-10-1997 17-10-1997 28-07-1998
WO 9701246 A	09-01-1997	AU 6480896 A	22-01-1997

Form PCT/ISA/210 (patent family annex) (July 1992)

RAPPORT DE RECHERCHE INTERNATIONALE

Dem. Internationale No
PCT/FR 99/00060

A. CLASSEMENT DE L'OBJET DE LA DEMANDE CIB 6 G08B21/00		
Selon la classification internationale des brevets (CIB) ou à la fois selon la classification nationale et la CIB		
B. DOMAINES SUR LESQUELS LA RECHERCHE A PORTE Documentation minimale consultée (système de classification suivi des symboles de classement) CIB 6 G08B		
Documentation consultée autre que la documentation minimale dans la mesure où ces documents relèvent des domaines sur lesquels a porté la recherche		
Base de données électronique consultée au cours de la recherche internationale (nom de la base de données, et si réalisable, termes de recherche utilisés)		
C. DOCUMENTS CONSIDERES COMME PERTINENTS		
Catégorie *	Identification des documents cités, avec, le cas échéant, l'indication des passages pertinents	no. des revendications visées
Y	DE 197 15 519 A (MITSUBISHI) 6 novembre 1997 voir le document en entier ---	1-18
Y	WO 97 01246 A (STEED VAN P.) 9 janvier 1997 voir abrégé ---	1-18
A	UENO H ET AL: "DEVELOPMENT OF DROWSINESS DETECTION SYSTEM" PROCEEDINGS OF THE VEHICLE NAVIGATION AND INFORMATION SYSTEMS CONFERENCE, YOKOHAMA, AUG. 31 - SEPT. 2, 1994, 31 août 1994, pages 15-20, XP000641294 INSTITUTE OF ELECTRICAL AND ELECTRONICS ENGINEERS -----	1-18
<input type="checkbox"/> Voir la suite du cadre C pour la fin de la liste des documents <input checked="" type="checkbox"/> Les documents de familles de brevets sont indiqués en annexe		
* Catégories spéciales de documents cités:		
"A" document définissant l'état général de la technique, non considéré comme particulièrement pertinent "E" document antérieur, mais publié à la date de dépôt international ou après cette date "L" document pouvant jeter un doute sur une revendication de priorité ou cité pour déterminer la date de publication d'une autre citation ou pour une raison spéciale (telle qu'indiquée) "O" document se référant à une divulgation orale, à un usage, à une exposition ou tous autres moyens "P" document publié avant la date de dépôt international, mais postérieurement à la date de priorité revendiquée		"T" document ultérieur publié après la date de dépôt international ou la date de priorité et n'appartenant pas à l'état de la technique pertinent, mais cité pour comprendre le principe ou la théorie constituant la base de l'invention "X" document particulièrement pertinent; l'invention revendiquée ne peut être considérée comme nouvelle ou comme impliquant une activité inventive par rapport au document considéré isolément "Y" document particulièrement pertinent; l'invention revendiquée ne peut être considérée comme impliquant une activité inventive lorsque le document est associé à un ou plusieurs autres documents de même nature, cette combinaison étant évidente pour une personne du métier "Z" document qui fait partie de la même famille de brevets
Date à laquelle la recherche internationale a été effectivement achevée 19 avril 1999		Date d'expédition du présent rapport de recherche internationale 23/04/1999
Nom et adresse postale de l'administration chargée de la recherche internationale Office Européen des Brevets, P.B. 5818 Patentlaan 2 NL - 2280 HV Rijswijk Tel. (+31-70) 340-2040, Tx. 31 651 epo nl, Fax: (+31-70) 340-3016		Fonctionnaire autorisé Sgura, S

1

Formulaire PCT/ISA/210 (deuxième feuille) (J48et 1992)

RAPPORT DE RECHERCHE INTERNATIONALE

Renseignements relatifs aux membres de familles de brevets

Dems. Internationale No
PCT/FR 99/00060

Document brevet cité au rapport de recherche	Date de publication	Membre(s) de la famille de brevet(s)	Date de publication
DE 19715519 A	06-11-1997	JP 9277849 A FR 2747346 A US 5786765 A	28-10-1997 17-10-1997 28-07-1998
WO 9701246 A	09-01-1997	AU 6480896 A	22-01-1997

Formulaire PCT/ISA/210 (annexe familles de brevets) (juillet 1992)

This Page Is Inserted by IFW Operations
and is not a part of the Official Record

BEST AVAILABLE IMAGES

Defective images within this document are accurate representations of the original documents submitted by the applicant.

Defects in the images may include (but are not limited to):

- BLACK BORDERS
- TEXT CUT OFF AT TOP, BOTTOM OR SIDES
- FADED TEXT
- ILLEGIBLE TEXT
- SKEWED/SLANTED IMAGES
- COLORED PHOTOS
- BLACK OR VERY BLACK AND WHITE DARK PHOTOS
- GRAY SCALE DOCUMENTS

IMAGES ARE BEST AVAILABLE COPY.

**As rescanning documents *will not* correct images,
please do not report the images to the
Image Problems Mailbox.**

CORRECTED
VERSION*

PCT

WORLD INTELLECTUAL PROPERTY ORGANIZATION
International Bureau



INTERNATIONAL APPLICATION PUBLISHED UNDER THE PATENT COOPERATION TREATY (PCT)

(51) International Patent Classification ⁶ : G08B 21/00	A1	(11) International Publication Number: WO 99/36893 (43) International Publication Date: 22 July 1999 (22.07.99)
(21) International Application Number: PCT/EP99/00300 (22) International Filing Date: 15 January 1999 (15.01.99) (30) Priority Data: 98/00378 15 January 1998 (15.01.98) FR PCT/EP98/05383 25 August 1998 (25.08.98) EP (63) Related by Continuation (CON) or Continuation-in-Part (CIP) to Earlier Application US PCT/EP98/05383 (CIP) Filed on 25 August 1998 (25.08.98) (71) Applicant (for all designated States except US): HOLDING B.E.V. S.A. [LU/LU]; 69, route d'Esch, L-Luxembourg (LU). (71)(72) Applicants and Inventors: PIRIM, Patrick [FR/FR]; 56, rue Patay, F-75013 Paris (FR). BINFORD, Thomas [US/US]; 16012 Flintlock Road, Cupertino, CA 95014 (US). (74) Agent: PHELIP, Bruno; Cabinet Harlé & Phélip, 7, rue de Madrid, F-75008 Paris (FR).	(81) Designated States: AL, AM, AT, AU, AZ, BA, BB, BG, BR, BY, CA, CH, CN, CU, CZ, DE, DK, EE, ES, FI, GB, GD, GE, GH, GM, HR, HU, ID, IL, IN, IS, JP, KE, KG, KP, KR, KZ, LC, LK, LR, LS, LT, LU, LV, MD, MG, MK, MN, MW, MX, NO, NZ, PL, PT, RO, RU, SD, SE, SG, SI, SK, SL, TJ, TM, TR, TT, UA, UG, US, UZ, VN, YU, ZW, ARIPO patent (GH, GM, KE, LS, MW, SD, SZ, UG, ZW), Eurasian patent (AM, AZ, BY, KG, KZ, MD, RU, TJ, TM), European patent (AT, BE, CH, CY, DE, DK, ES, FI, FR, GB, GR, IE, IT, LU, MC, NL, PT, SE), OAPI patent (BF, BJ, CF, CG, CI, CM, GA, GN, GW, ML, MR, NE, SN, TD, TG). Published <i>With international search report. Before the expiration of the time limit for amending the claims and to be republished in the event of the receipt of amendments.</i>	
(54) Title: METHOD AND APPARATUS FOR DETECTION OF DROWSINESS		
(57) Abstract <p>In a process of detecting a person falling asleep, an image of the face of the person is acquired. Pixels of the image having characteristics corresponding to an eye of the person are selected and a histogram is formed of the selected pixels. The histogram is analyzed over time to identify each opening and closing of the eye, and characteristics indicative of the person falling asleep are determined. A sub-area of the image including the eye may be determined by identifying the head or a facial characteristic of the person, and then identifying the sub-area using an anthropomorphic model. To determine openings and closings of the eyes, histograms of shadowed pixels of the eye are analyzed to determine the width and height of the shadowing, or histograms of movement corresponding to blinking are analyzed. An apparatus for detecting a person falling asleep includes a sensor for acquiring an image of the face of the person, a controller, and a histogram formation unit for forming a histogram on pixels having selected characteristics. Also disclosed is a rear-view mirror assembly incorporating the apparatus.</p>		

* (Referred to in PCT Gazette No. 39/1999, Section II)

FOR THE PURPOSES OF INFORMATION ONLY

Codes used to identify States party to the PCT on the front pages of pamphlets publishing international applications under the PCT.

AL	Albania	ES	Spain	LS	Lesotho	SI	Slovenia
AM	Armenia	FI	Finland	LT	Lithuania	SK	Slovakia
AT	Austria	FR	France	LU	Luxembourg	SN	Senegal
AU	Australia	GA	Gabon	LV	Latvia	SZ	Swaziland
AZ	Azerbaijan	GB	United Kingdom	MC	Monaco	TD	Chad
BA	Bosnia and Herzegovina	GE	Georgia	MD	Republic of Moldova	TG	Togo
BB	Barbados	GH	Ghana	MG	Madagascar	TJ	Tajikistan
BE	Belgium	GN	Guinea	MK	The former Yugoslav Republic of Macedonia	TM	Turkmenistan
BF	Burkina Faso	GR	Greece	ML	Mali	TR	Turkey
BG	Bulgaria	HU	Hungary	MN	Mongolia	TT	Trinidad and Tobago
BJ	Benin	IE	Ireland	MR	Mauritania	UA	Ukraine
BR	Brazil	IL	Israel	MW	Malawi	UG	Uganda
BY	Belarus	IS	Iceland	MX	Mexico	US	United States of America
CA	Canada	IT	Italy	NE	Niger	UZ	Uzbekistan
CF	Central African Republic	JP	Japan	NL	Netherlands	VN	Viet Nam
CG	Congo	KE	Kenya	NO	Norway	YU	Yugoslavia
CH	Switzerland	KG	Kyrgyzstan	NZ	New Zealand	ZW	Zimbabwe
CI	Côte d'Ivoire	KP	Democratic People's Republic of Korea	PL	Poland		
CM	Cameroun	KR	Republic of Korea	PT	Portugal		
CN	China	KZ	Kazakistan	RO	Romania		
CU	Cuba	LC	Saint Lucia	RU	Russian Federation		
CZ	Czech Republic	LI	Liechtenstein	SD	Sudan		
DE	Germany	LK	Sri Lanka	SE	Sweden		
DK	Denmark	LR	Liberia	SG	Singapore		
EE	Estonia						

METHOD AND APPARATUS FOR DETECTION OF DROWSINESS

5 BACKGROUND OF THE INVENTION

1. Field of the Invention.

The present invention relates generally to an image processing system, and more particularly to the use of a generic image processing system to detect drowsiness.

10 1. Description of the Related Art.

It is well known that a significant number of highway accidents result from drivers becoming drowsy or falling asleep, which results in many deaths and injuries. Drowsiness is also a problem in other fields, such as for airline pilots and power plant operators, in which great damage may result from failure to stay alert.

15 A number of different physical criteria may be used to establish when a person is drowsy, including a change in the duration and interval of eye blinking. Normally, the duration of blinking is about 100 to 200 ms when awake and about 500 to 800 ms when drowsy. The time interval between successive blinks is generally constant while awake, but varies within a relatively broad range when drowsy.

20 Numerous devices have been proposed to detect drowsiness of drivers. Such devices are shown, for example, in U.S. Patent Nos. 5,841,354; 5,813,99; 5,689,241; 5,684,461; 5,682,144; 5,469,143; 5,402,109; 5,353,013; 5,195,606; 4,928,090; 4,555,697; 4,485,375; and 4,259,665. In general, these devices fall into three categories: i) devices that detect movement of the head of the driver, e.g., tilting; ii)
25 devices that detect a physiological change in the driver, e.g., altered heartbeat or breathing, and iii) devices that detect a physical result of the driver falling asleep, e.g., a reduced grip on the steering wheel. None of these devices is believed to have met with commercial success.

Commonly-owned PCT Application Serial Nos. PCT/FR97/01354 and
30 PCT/EP98/05383 disclose a generic image processing system that operates to localize

objects in relative movement in an image and to determine the speed and direction of the objects in real-time. Each pixel of an image is smoothed using its own time constant. A binary value corresponding to the existence of a significant variation in the amplitude of the smoothed pixel from the prior frame, and the amplitude of the variation, are determined, and the time constant for the pixel is updated. For each particular pixel, two matrices are formed that include a subset of the pixels spatially related to the particular pixel. The first matrix contains the binary values of the subset of pixels. The second matrix contains the amplitude of the variation of the subset of pixels. In the first matrix, it is determined whether the pixels along an oriented direction relative to the particular pixel have binary values representative of significant variation, and, for such pixels, it is determined in the second matrix whether the amplitude of these pixels varies in a known manner indicating movement in the oriented direction. In domains that include luminance, hue, saturation, speed, oriented direction, time constant, and x and y position, a histogram is formed of the values in the first and second matrices falling in user selected combinations of such domains. Using the histograms, it is determined whether there is an area having the characteristics of the selected combinations of domains.

It would be desirable to apply such a generic image processing system to detect the drowsiness of a person.

SUMMARY OF THE INVENTION

The present invention is a process of detecting a driver falling asleep in which an image of the face of the driver is acquired. Pixels of the image having characteristics corresponding to characteristics of at least one eye of the driver are selected and a histogram is formed of the selected pixels. The histogram is analyzed over time to identify each opening and closing of the eye, and from the eye opening and closing information, characteristics indicative of a driver falling asleep are determined.

In one embodiment, a sub-area of the image comprising the eye is determined prior to the step of selecting pixels of the image having characteristics corresponding to characteristics of an eye. In this embodiment, the step of selecting pixels of the image having characteristics of an eye involves selecting pixels within the sub-area of the image. The step of identifying a sub-area of the image preferably involves identifying the head of

the driver, or a facial characteristic of the driver, such as the driver's nostrils, and then identifying the sub-area of the image using an anthropomorphic model. The head of the driver may be identified by selecting pixels of the image having characteristics corresponding to edges of the head of the driver. Histograms of the selected pixels of the edges of the driver's head are projected onto orthogonal axes. These histograms are then analyzed to identify the edges of the driver's head.

The facial characteristic of the driver may be identified by selecting pixels of the image having characteristics corresponding to the facial characteristic. Histograms of the selected pixels of the facial characteristic are projected onto orthogonal axes. These histograms are then analyzed to identify the facial characteristic. If desired, the step of identifying the facial characteristic in the image involves searching sub-images of the image until the facial characteristic is found. In the case in which the facial characteristic is the nostrils of the driver, a histogram is formed of pixels having low luminance levels to detect the nostrils. To confirm detection of the nostrils, the histograms of the nostril pixels may be analyzed to determine whether the spacing between the nostrils is within a desired range and whether the dimensions of the nostrils fall within a desired range. In order to confirm the identification of the facial characteristic, an anthropomorphic model and the location of the facial characteristic are used to select a sub-area of the image containing a second facial characteristic. Pixels of the image having characteristics corresponding to the second facial characteristic are selected and a histograms of the selected pixels of the second facial characteristic are analyzed to confirm the identification of the first facial characteristic.

In order to determine openings and closings of the eyes of the driver, the step of selecting pixels of the image having characteristics corresponding to characteristics of an eye of the driver involves selecting pixels having low luminance levels corresponding to shadowing of the eye. In this embodiment, the step analyzing the histogram over time to identify each opening and closing of the eye involves analyzing the shape of the eye shadowing to determine openings and closings of the eye. The histograms of shadowed pixels are preferably projected onto orthogonal axes, and the step of analyzing the shape of the eye shadowing involves analyzing the width and height of the shadowing.

An alternative method of determining openings and closings of the eyes of the driver involves selecting pixels of the image having characteristics of movement corresponding to blinking. In this embodiment, the step analyzing the histogram over time to identify each opening and closing of the eye involves analyzing the number of pixels in movement corresponding to blinking over time. The characteristics of a blinking eye are preferably selected from the group consisting of i) DP=1, ii) CO indicative of a blinking eyelid, iii) velocity indicative of a blinking eyelid, and iv) up and down movement indicative of a blinking eyelid.

An apparatus for detecting a driver falling asleep includes a sensor for acquiring an image of the face of the driver, a controller, and a histogram formation unit for forming a histogram on pixels having selected characteristics. The controller controls the histogram formation unit to select pixels of the image having characteristics corresponding to characteristics of at least one eye of the driver and to form a histogram of the selected pixels. The controller analyzes the histogram over time to identify each opening and closing of the eye, and determines from the opening and closing information on the eye, characteristics indicative of the driver falling asleep.

In one embodiment, the controller interacts with the histogram formation unit to identify a sub-area of the image comprising the eye, and the controller controls the histogram formation unit to select pixels of the image having characteristics corresponding to characteristics of the eye only within the sub-area of the image. In order to select the sub-area of the image, the controller interacts with the histogram formation unit to identify the head of the driver in the image, or a facial characteristic of the driver, such as the driver's nostrils. The controller then identifies the sub-area of the image using an anthropomorphic model. To identify the head of the driver, the histogram formation unit selects pixels of the image having characteristics corresponding to edges of the head of the driver and forms histograms of the selected pixels projected onto orthogonal axes. To identify a facial characteristic of the driver, the histogram formation unit selects pixels of the image having characteristics corresponding to the facial characteristic and forms histograms of the selected pixels projected onto orthogonal axes. The controller then analyzes the histograms of the selected pixels to

identify the edges of the head of the driver or the facial characteristic, as the case may be. If the facial characteristic is the nostrils of the driver, the histogram formation unit selects pixels of the image having low luminance levels corresponding to the luminance level of the nostrils. The controller may also analyze the histograms of the nostril pixels to
5 determine whether the spacing between the nostrils is within a desired range and whether dimensions of the nostrils fall within a desired range. If desired, the controller may interact with the histogram formation unit to search sub-images of the image to identify the facial characteristic.

In order to verify identification of the facial characteristic, the controller uses an
10 anthropomorphic model and the location of the facial characteristic to cause the histogram formation unit to select a sub-area of the image containing a second facial characteristic. The histogram formation unit selects pixels of the image in the sub-area having characteristics corresponding to the second facial characteristic and forms a histogram of such pixels. The controller then analyzes the histogram of the selected
15 pixels corresponding to the second facial characteristic to identify the second facial characteristic and to thereby confirm the identification of the first facial characteristic.

In one embodiment, the histogram formation unit selects pixels of the image having low luminance levels corresponding to shadowing of the eyes, and the controller then analyzes the shape of the eye shadowing to identify shapes corresponding to
20 openings and closings of the eye. The histogram formation unit preferably forms histograms of the shadowed pixels of the eye projected onto orthogonal axes, and the controller analyzes the width and height of the shadowing to determine openings and closings of the eye.

In an alternative embodiment, the histogram formation unit selects pixels of the
25 image in movement corresponding to blinking and the controller analyzes the number of pixels in movement over time to determine openings and closings of the eye. The characteristics of movement corresponding to blinking are preferably selected from the group consisting of i) DP=1, ii) CO indicative of a blinking eyelid, iii) velocity indicative of a blinking eyelid, and iv) up and down movement indicative of a blinking eyelid.

If desired, the sensor may be integrally constructed with the controller and the histogram formation unit. The apparatus may comprise an alarm, which the controller operates upon detection of the driver falling asleep, and may comprise an illumination source, such as a source of IR radiation, with the sensor being adapted to view the driver when illuminated by the illumination source.

A rear-view mirror assembly comprises a rear-view mirror and the described apparatus for detecting driver drowsiness mounted to the rear-view mirror. In one embodiment, a bracket attaches the apparatus to the rear-view mirror. In an alternative embodiment, the rear-view mirror comprises a housing having an open side and an interior. The rear-view mirror is mounted to the open side of the housing, and is see-through from the interior of the housing to the exterior of the housing. The drowsiness detection apparatus is mounted interior to the housing with the sensor directed toward the rear-view mirror. If desired, a joint attaches the apparatus to the rear-view mirror assembly, with the joint being adapted to maintain the apparatus in a position facing the driver during adjustment of the mirror assembly by the driver. The rear-view mirror assembly may include a source of illumination directed toward the driver, with the sensor adapted to view the driver when illuminated by the source of illumination. The rear-view mirror assembly may also include an alarm, with the controller operating the alarm upon detection of the driver falling asleep. Also disclosed is a vehicle comprising the drowsiness detection device.

BRIEF DESCRIPTION OF THE DRAWINGS

Fig. 1 is a diagrammatic illustration of the system according to the invention.

Fig. 2 is a block diagram of the temporal and spatial processing units of the invention.

Fig. 3 is a block diagram of the temporal processing unit of the invention.

Fig. 4 is a block diagram of the spatial processing unit of the invention.

Fig. 5 is a diagram showing the processing of pixels in accordance with the invention.

Fig. 6 illustrates the numerical values of the Freeman code used to determine movement direction in accordance with the invention.

Fig. 7 illustrates nested matrices as processed by the temporal processing unit.

Fig. 8 illustrates hexagonal matrices as processed by the temporal processing unit.

Fig. 9 illustrates reverse-L matrices as processed by the temporal processing unit.

5 Fig. 10 illustrates angular sector shaped matrices as processed by the temporal processing unit.

Fig. 11 is a block diagram showing the relationship between the temporal and spatial processing units, and the histogram formation units.

10 Fig. 12 is a block diagram showing the interrelationship between the various histogram formation units.

Fig. 13 shows the formation of a two-dimensional histogram of a moving area from two one-dimensional histograms.

Fig. 14 is a block diagram of an individual histogram formation unit.

15 Figs. 15A and 15B illustrate the use of a histogram formation unit to find the orientation of a line relative to an analysis axis.

Fig. 16 illustrates a one-dimensional histogram.

Fig. 17 illustrates the use of semi-graphic sub-matrices to selected desired areas of an image.

20 Fig. 18 is a side view illustrating a rear view mirror in combination with the drowsiness detection system of the invention.

Fig. 19 is a top view illustrating operation of a rear view mirror.

Fig. 20 is a schematic illustrating operation of a rear view mirror.

Fig. 21 is a cross-sectional top view illustrating a rear view mirror assembly incorporating the drowsiness detection system of the invention.

25 Fig. 22 is a partial cross-sectional top view illustrating a joint supporting the drowsiness detection system of the invention in the mirror assembly of Fig. 21.

Fig. 23 is a top view illustrating the relationship between the rear view mirror assembly of Fig. 21 and a driver.

30 Fig. 24 illustrates detection of the edges of the head of a person using the system of the invention.

Fig. 25 illustrates masking outside of the edges of the head of a person.

Fig. 26 illustrates masking outside of the eyes of a person.

Fig. 27 illustrates detection of the eyes of a person using the system of the invention.

5 Fig. 28 illustrates successive blinks in a three-dimensional orthogonal coordinate system.

Figs. 29A and 29B illustrate conversion of peaks and valleys of eye movement histograms to information indicative of blinking.

10 Fig. 30 is a flow diagram illustrating the use of the system of the invention to detect drowsiness.

Fig. 31 illustrates the use of sub-images to search a complete image.

Fig. 32 illustrates the use of the system of the invention to detect nostrils and to track eye movement.

Fig. 33 illustrates the use of the system of the invention to detect an open eye.

15 Fig. 34 illustrates the use of the system of the invention to detect a closed eye.

Fig. 35 is a flow diagram of an alternative method of detecting drowsiness.

Fig. 36 illustrates use of the system to detect a pupil.

DETAILED DESCRIPTION OF THE INVENTION

20 The present invention discloses an application of the generic image processing system disclosed in commonly-owned PCT Application Serial Nos. PCT/FR97/01354 and PCT/EP98/05383, the contents of which are incorporated herein by reference for detection of various criteria associated with the human eye, and especially to detection that a driver is falling asleep while driving a vehicle.

25 The apparatus of the invention is similar to that described in the aforementioned PCT Application Serial Nos. PCT/FR97/01354 and PCT/EP98/05383, which will be described herein for purposes of clarity. Referring to Figs. 1 and 10, the generic image processing system 22 includes a spatial and temporal processing unit 11 in combination with a histogram formation unit 22a. Spatial and temporal processing unit 11 includes an input 12 that receives a digital video signal S originating from a video camera or other
30 imaging device 13 which monitors a scene 13a. Imaging device 13 is preferably a

conventional CMOS-type CCD camera, which for purposes of the presently-described invention is mounted on a vehicle facing the driver. It will be appreciated that when used in non-vehicular applications, the camera may be mounted in any desired fashion to detect the specific criteria of interest. It is also foreseen that any other appropriate
5 sensor, e.g., ultrasound, IR, Radar, etc., may be used as the imaging device. Imaging device 13 may have a direct digital output, or an analog output that is converted by an A/D converter into digital signal S. Imaging device 13 may also be integral with generic image processing system 22, if desired.

While signal S may be a progressive signal, it is preferably composed of a
10 succession of pairs of interlaced frames, TR_1 and TR'_1 and TR_2 and TR'_2 , each consisting of a succession of horizontal scanned lines, e.g., $l_{1,1}, l_{1,2}, \dots, l_{1,17}$ in TR_1 , and 2_1 in TR_2 . Each line consists of a succession of pixels or image-points PI, e.g., $a_{1,1}, a_{1,2}$ and $a_{1,3}$ for line $l_{1,1}$; $a_{17,1}$ and $a_{17,2}$ for line $l_{1,17}$; $a_{1,1}$ and $a_{1,2}$ for line $l_{2,1}$. Signal S(PI) represents signal S composed of pixels PI.

15 S(PI) includes a frame synchronization signal (ST) at the beginning of each frame, a line synchronization signal (SL) at the beginning of each line, and a blanking signal (BL). Thus, S(PI) includes a succession frames, which are representative of the time domain, and within each frame, a series of lines and pixels, which are representative of the spatial domain.

20 In the time domain, "successive frames" shall refer to successive frames of the same type (i.e., odd frames such as TR_1 or even frames such as TR'_1), and "successive pixels in the same position" shall denote successive values of the pixels (PI) in the same location in successive frames of the same type, e.g., $a_{1,1}$ of $l_{1,1}$ in frame TR_1 and $a_{1,1}$ of $l_{1,1}$ in the next corresponding frame TR_2 .

25 Spatial and temporal processing unit 11 generates outputs ZH and SR 14 to a data bus 23 (Fig. 11), which are preferably digital signals. Complex signal ZH comprises a number of output signals generated by the system, preferably including signals indicating the existence and localization of an area or object in motion, and the speed V and the oriented direction of displacement DI of each pixel of the image. Also preferably
30 output from the system is input digital video signal S, which is delayed (SR) to make it

synchronous with the output ZH for the frame, taking into account the calculation time for the data in composite signal ZH (one frame). The delayed signal SR is used to display the image received by camera 13 on a monitor or television screen 10, which may also be used to display the information contained in composite signal ZH. Composite signal ZH may also be transmitted to a separate processing assembly 10a in which further processing of the signal may be accomplished.

Referring to Fig. 2, spatial and temporal processing unit 11 includes a first assembly 11a, which consists of a temporal processing unit 15 having an associated memory 16, a spatial processing unit 17 having a delay unit 18 and sequencing unit 19, and a pixel clock 20, which generates a clock signal HP, and which serves as a clock for temporal processing unit 15 and sequencing unit 19. Clock pulses HP are generated by clock 20 at the pixel rate of the image, which is preferably 13.5 MHz.

Fig. 3 shows the operation of temporal processing unit 15, the function of which is to smooth the video signal and generate a number of outputs that are utilized by spatial processing unit 17. During processing, temporal processing unit 15 retrieves from memory 16 the smoothed pixel values LI of the digital video signal from the immediately prior frame, and the values of a smoothing time constant CI for each pixel. As used herein, LO and CO shall be used to denote the pixel values (L) and time constants (C) stored in memory 16 from temporal processing unit 15, and LI and CI shall denote the pixel values (L) and time constants (C) respectively for such values retrieved from memory 16 for use by temporal processing unit 15. Temporal processing unit 15 generates a binary output signal DP for each pixel, which identifies whether the pixel has undergone significant variation, and a digital signal CO, which represents the updated calculated value of time constant C.

Referring to Fig. 3, temporal processing unit 15 includes a first block 15a which receives the pixels PI of input video signal S. For each pixel PI, the temporal processing unit retrieves from memory 16 a smoothed value LI of this pixel from the immediately preceding corresponding frame, which was calculated by temporal processing unit 15 during processing of the immediately prior frame and stored in memory 16 as LO. Temporal processing unit 15 calculates the absolute value AB of the difference between

each pixel value PI and LI for the same pixel position (for example $a_{1,1}$, of $l_{1,1}$ in TR_1 and of $l_{1,1}$ in TR_2):

$$AB = |PI-LI$$

Temporal processing unit 15 is controlled by clock signal HP from clock 20 in order to maintain synchronization with the incoming pixel stream. Test block 15b of temporal processing unit 15 receives signal AB and a threshold value SE. Threshold SE may be constant, but preferably varies based upon the pixel value PI, and more preferably varies with the pixel value so as to form a gamma correction. Known means of varying SE to form a gamma correction is represented by the optional block 15e shown in dashed lines. Test block 15b compares, on a pixel-by-pixel basis, digital signals AB and SE in order to determine a binary signal DP. If AB exceeds threshold SE, which indicates that pixel value PI has undergone significant variation as compared to the smoothed value LI of the same pixel in the prior frame, DP is set to "1" for the pixel under consideration. Otherwise, DP is set to "0" for such pixel.

When $DP = 1$, the difference between the pixel value PI and smoothed value LI of the same pixel in the prior frame is considered too great, and temporal processing unit 15 attempts to reduce this difference in subsequent frames by reducing the smoothing time constant C for that pixel. Conversely, if $DP = 0$, temporal processing unit 15 attempts to increase this difference in subsequent frames by increasing the smoothing time constant C for that pixel. These adjustments to time constant C as a function of the value of DP are made by block 15c. If $DP = 1$, block 15c reduces the time constant by a unit value U so that the new value of the time constant CO equals the old value of the constant CI minus unit value U.

$$CO=CI-U$$

If $DP = 0$, block 15c increases the time constant by a unit value U so that the new value of the time constant CO equals the old value of the constant CI plus unit value U.

$$CO=CI+U$$

Thus, for each pixel, block 15c receives the binary signal DP from test unit 15b and time constant CI from memory 16, adjusts CI up or down by unit value U, and

generates a new time constant CO which is stored in memory 16 to replace time constant CI.

In a preferred embodiment, time constant C, is in the form 2^p , where p is incremented or decremented by unit value U, which preferably equals 1, in block 15c. Thus, if DP = 1, block 15c subtracts one (for the case where U=1) from p in the time constant 2^p which becomes 2^{p-1} . If DP = 0, block 15c adds one to p in time constant 2^p , which becomes 2^{p+1} . The choice of a time constant of the form 2^p facilitates calculations and thus simplifies the structure of block 15c.

Block 15c includes several tests to ensure proper operation of the system. First, CO must remain within defined limits. In a preferred embodiment, CO must not become negative ($CO \geq 0$) and it must not exceed a limit N ($CO \leq N$), which is preferably seven. In the instance in which CI and CO are in the form 2^p , the upper limit N is the maximum value for p.

The upper limit N may be constant, but is preferably variable. An optional input unit 15f includes a register of memory that enables the user, or controller 42 to vary N. The consequence of increasing N is to increase the sensitivity of the system to detecting displacement of pixels, whereas reducing N improves detection of high speeds. N may be made to depend on PI (N may vary on a pixel-by-pixel basis, if desired) in order to regulate the variation of LO as a function of the level of PI, i.e., $N_{ijt} = f(PI_{ijt})$, the calculation of which is done in block 15f, which in this case would receive the value of PI from video camera 13.

Finally, a calculation block 15d receives, for each pixel, the new time constant CO generated in block 15c, the pixel values PI of the incoming video signal S, and the smoothed pixel value LI of the pixel in the previous frame from memory 16. Calculation block 15d then calculates a new smoothed pixel value LO for the pixel as follows:

$$LO = LI + (PI - LI)/CO$$

If $CO = 2^p$, then

$$LO = LI + (PI - LI)/2^{p^o}$$

where "po", is the new value of p calculated in unit 15c and which replaces previous value of "pi" in memory 16.

The purpose of the smoothing operation is to normalize variations in the value of each pixel PI of the incoming video signal for reducing the variation differences. For each pixel of the frame, temporal processing unit 15 retrieves LI and CI from memory 16, and generates new values LO (new smoothed pixel value) and CO (new time constant) that are stored in memory 16 to replace LI and CI respectively. As shown in Fig. 2, temporal processing unit 15 transmits the CO and DP values for each pixel to spatial processing unit 17 through the delay unit 18.

The capacity of memory 16 assuming that there are R pixels in a frame, and therefore 2R pixels per complete image, must be at least $2R(e+f)$ bits, where e is the number of bits required to store a single pixel value LI (preferably eight bits), and f is the number of bits required to store a single time constant CI (preferably 3 bits). If each video image is composed of a single frame (progressive image), it is sufficient to use $R(e+f)$ bits rather than $2R(e+f)$ bits.

Spatial processing unit 17 is used to identify an area in relative movement in the images from camera 13 and to determine the speed and oriented direction of the movement. Spatial processing unit 17, in conjunction with delay unit 18, co-operates with a control unit 19 that is controlled by clock 20, which generates clock pulse HP at the pixel frequency. Spatial processing unit 17 receives signals DP_{ij} and CO_{ij} (where i and j correspond to the x and y coordinates of the pixel) from temporal processing unit 15 and processes these signals as discussed below. Whereas temporal processing unit 15 processes pixels within each frame, spatial processing unit 17 processes groupings of pixels within the frames.

Fig. 5 diagrammatically shows the temporal processing of successive corresponding frame sequences TR_1 , TR_2 , TR_3 and the spatial processing in these frames of a pixel PI with coordinates x, y, at times t_1 , t_2 , and t_3 . A plane in Fig. 5 corresponds to the spatial processing of a frame, whereas the superposition of frames corresponds to the temporal processing of successive frames.

Signals DP_{ij} and CO_{ij} from temporal processing unit 15 are distributed by spatial processing unit 17 into a first matrix 21 containing a number of rows and columns much smaller than the number of lines L of the frame and the number of pixels M per line.

Matrix 21 preferably includes $2l + 1$ lines along the y axis and $2m+1$ columns along the x axis (in Cartesian coordinates), where l and m are small integer numbers. Advantageously, l and m are chosen to be powers of 2, where for example l is equal to 2^a and m is equal to 2^b , a and b being integer numbers of about 2 to 5, for example. To
 5 simplify the drawing and the explanation, m will be taken to be equal to l (although it may be different) and $m=l=2^3=8$. In this case, matrix 21 will have $2 \times 8 + 1 = 17$ rows and 17 columns. Fig. 4 shows a portion of the 17 rows $Y_0, Y_1, \dots, Y_{15}, Y_{16}$, and 17 columns $X_0, X_1, \dots, X_{15}, X_{16}$ which form matrix 21.

Spatial processing unit 17 distributes into $l \times m$ matrix 21 the incoming flows of
 10 DP_{ijt} and CO_{jt} from temporal processing unit 15. It will be appreciated that only a subset of all DP_{ijt} and CO_{jt} values will be included in matrix 21, since the frame is much larger, having L lines and M pixels per row (e.g., 312.5 lines and 250-800 pixels), depending upon the TV standard used.

In order to distinguish the $L \times M$ matrix of the incoming video signal from the $l \times$
 15 m matrix 21 of spatial processing unit 17, the indices i and j will be used to represent the coordinates of the former matrix and the indices x and y will be used to represent the coordinates of the latter. At a given instant, a pixel with an instantaneous value PI_{ijt} is characterized at the input of the spatial processing unit 17 by signals DP_{ijt} and CO_{jt} . The $(2l+1) \times (2m + 1)$ matrix 21 is formed by scanning each of the $L \times M$ matrices for DP
 20 and CO .

In matrix 21, each pixel is defined by a row number between 0 and 16 (inclusive), for rows Y_0 to Y_{16} respectively, and a column number between 0 and 16 (inclusive), for columns X_0 to X_{16} respectively, in the case in which $l = m = 8$. In this case, matrix 21 will be a plane of $17 \times 17 = 289$ pixels.

In Fig. 4, elongated horizontal rectangles Y_0 to Y_{16} (only four of which have been
 25 shown, i.e., Y_0, Y_1, Y_{15} and Y_{16}) and vertical lines X_0 to X_{16} (of which only four have been shown, i.e., X_0, X_1, X_{15} and X_{16}) illustrate matrix 21 with 17×17 image points or pixels having indices defined at the intersection of an ordinate row and an abscissa column. For example, the P_{88} is at the intersection of column 8 and row 8 as illustrated
 30 in Fig. 4 at position e, which is the center of matrix 21.

In response to the HP and BL signals from clock 20 (Fig. 2), a rate control or sequencing unit 19: i) generates a line sequence signal SL at a frequency equal to the quotient of 13.5 MHz (for an image with a corresponding number of pixels) divided by the number of columns per frame (for example 400) to delay unit 18, ii) generates a frame signal SC, the frequency of which is equal to the quotient 13.5/400 MHz divided by the number of rows in the video image, for example 312.5, iii) and outputs the HP clock signal. Blanking signal BL is used to render sequencing unit 19 non-operational during synchronization signals in the input image.

A delay unit 18 carries out the distribution of portions of the $L \times M$ matrix into matrix 21. Delay unit 18 receives the DP, CO, and incoming pixel S(PI) signals, and distributes these into matrix 21 using clock signal HP and line sequence and column sequence signals SL and SC.

In order to form matrix 21 from the incoming stream of DP and CO signals, the successive row, Y_0 to Y_{16} for the DP and CO signals must be delayed as follows:

- row Y_0 - not delayed;
- row Y_1 - delayed by the duration of a frame line TP;
- row Y_2 - delayed by 2 TP;
- and so on until
- row Y_{16} - delayed by 16 TP.

The successive delays of the duration of a frame row TP, are carried out in a cascade of sixteen delay circuits r_1, r_2, \dots, r_{16} that serve rows Y_1, Y_2, \dots, Y_{16} , respectively, row Y_0 being served directly by the DP and CO signals without any delay upon arriving from temporal processing unit 15. All delay circuits r_1, r_2, \dots, r_{16} may be built up by a delay line with sixteen outputs, the delay imposed by any section thereof between two successive outputs being constant and equal to TP.

Rate control unit 19 controls the scanning of the entire $L \times M$ frame matrix over matrix 21. The circular displacement of pixels in a row of the frame matrix on the 17×17 matrix, for example from X_0 to X_{16} on row Y_0 , is done by a cascade of sixteen shift registers d on each of the 17 rows from Y_0 to Y_{16} (giving a total of $16 \times 17 = 272$ shift registers) placed in each row between two successive pixel positions, namely the register

d₀₁ between positions PI₀₀ and PI₀₁ register d₀₂ between positions PI₀₁ and PI₀₂, etc. Each register imposes a delay TS equal to the time difference between two successive pixels in a row or line, using column sequence signal SC. Because rows l₁, l₂ ... l₁₇ in a frame TR₁ (Fig. 1), for S(PI) and for DP and CO, reach delay unit 18 shifted by TP (complete duration of a row) one after the other, and delay unit 18 distributes them with gradually increasing delays of TP onto rows Y₀, Y₁ ... Y₁₇, these rows display the DP and CO signals at a given time for rows l₁, l₂ ... l₁₇ in the same frame portion. Similarly in a given row, e.g., l₁, successive pixel signals a_{1,1}, a_{1,2} ... arrive shifted by TS and shift registers d impose a delay also equal to TS. As a result, the pixels of the DP and CO signals in a given row Y₀ to Y₁₆ in matrix 21, are contemporary, i.e., they correspond to the same frame portion.

The signals representing the COs and DPs in matrix 21 are available at a given instant on the 16 x 17 = 272 outputs of the shift registers, as well as upstream of the registers ahead of the 17 rows, i.e., registers d_{0,1}, d_{1,1}... d_{16,1}, which makes a total of 16 x 17 + 17 = 17 x 17 outputs for the 17 x 17 positions P_{0,0}, P_{0,1}, ... P_{8,8}... P_{16,16}.

In order to better understand the process of spatial processing, the system will be described with respect to a small matrix M3 containing 3 rows and 3 columns where the central element of the 9 elements thereof is pixel e with coordinates x = 8, y = 8 as illustrated below:

20	a b c	
	d e f	(M3)
	g h i	

In matrix M3, positions a, b, c, d, f, g, h, i around the central pixel e correspond to eight oriented directions relative to the central pixel. The eight directions may be identified using the Freeman code illustrated in Fig. 6, the directions being coded 0 to 7 starting from the x axis, in steps of 45°. In the Freeman code, the eight possible oriented directions, may be represented by a 3-bit number since 2³ = 8.

Considering matrix M3, the 8 directions of the Freeman code are as follows:

30

17

3	2	1
4	e	0
5	6	7

5 Returning to matrix 21 having 17 x 17 pixels, a calculation unit 17a examines at the same time various nested square second matrices centered on e, with dimensions 15 x 15, 13 x 13, 11 x 11, 9 x 9, 7 x 7, 5 x 5 and 3 x 3, within matrix 21, the 3 x 3 matrix being the M3 matrix mentioned above. Spatial processing unit 17 determines which matrix is the smallest in which pixels with DP = 1 are aligned along a straight line which
10 determines the direction of movement of the aligned pixels.

For the aligned pixels in the matrix, the system determines if CO varies on each side of the central position in the direction of alignment, from +a in an oriented direction and -a in the opposite oriented direction, where $1 < a < N$. For example, if positions g, e, and c of M3 have values -1, 0, +1, then a displacement exists in this matrix from right to left in the (oriented) direction 1 in the Freeman code (Fig. 6). However, positions g, e,
15 and c must at the same time have DP = 1. The displacement speed of the pixels in motion is greater when the matrix, among the 3 x 3 to 15 x 15 nested matrices, in which CO varies from +1 or -1 between two adjacent positions along a direction is larger. For example, if positions g, e, and c in the 9 x 9 matrix denoted M9 have values -1, 0, +1 in
20 oriented direction 1, the displacement will be faster than for values -1, 0, +1 in 3 x 3 matrix M3 (Fig. 7). The smallest matrix for which a line meets the test of DP=1 for the pixels in the line and CO varies on each side of the central position in the direction of alignment, from +a in an oriented direction and -a in the opposite oriented direction, is chosen as the principal line of interest.

25 Within a given matrix, a greater value of ΔCO indicates slower movement. For example, in the smallest matrix, i.e., the 3x3 matrix, $CO = \Delta 2$ with $DPs=1$ determines subpixel movement i.e. one half pixel per image, and $CO = \Delta 3$, indicates slower movement, i.e. one third of a pixel per image. In order to reduce the calculation power in the system and to simplify the hardware, preferably only those values of CO which are
30 symmetrical relative to the central pixel are considered.

Since CO is represented as a power of 2 in a preferred embodiment, an extended range of speeds may be identified using only a few bits for CO, while still enabling identification of relatively low speeds. Varying speed may be detected because, for example -2, 0, +2 in positions g, e, c in 3 x 3 matrix M3 indicates a speed half as fast as the speed corresponding to 1, 0, +1 for the same positions in matrix M3.

Two tests are preferably performed on the results to remove uncertainties. The first test chooses the strongest variation, in other words the highest time constant, if there are variations of CO along several directions in one of the nested matrices. The second test arbitrarily chooses one of two (or more) directions along which the variation of CO is identical, for example by choosing the smallest value of the Freeman code, in the instance when identical lines of motion are directed in a single matrix in different directions. This usually arises when the actual direction of displacement is approximately between two successive coded directions in the Freeman code, for example between directions 1 and 2 corresponding to an (oriented) direction that can be denoted 1.5 (Fig. 6) of about 67.5° with the x axis direction (direction 0 in the Freeman code).

The scanning of an entire frame of the digital video signal S preferably occurs in the following sequence. The first group of pixels considered is the first 17 rows or lines of the frame, and the first 17 columns of the frame. Subsequently, still for the first 17 rows of the frame, the matrix is moved column by column from the left of the frame to the right, as shown in Fig. 5, i.e., from portion TM₁ at the extreme left, then TM₂ offset by one column with respect to TM₁, until TM_M (where M is the number of pixels per frame line or row) at the extreme right. Once the first 17 rows have been considered for each column from left to right, the process is repeated for rows 2 to 18 in the frame. This process continues, shifting down one row at a time until the last group of lines at the bottom of the frame, i.e., lines L - 16 ... L (where L is the number of lines per frame) are considered.

Spatial processing unit 17 generates the following output signals for each pixel: i) a signal V representing the displacement speed for the pixel, based upon the amplitude of the maximum variation of CO surrounding the pixel, the value of which may be, for example, represented by an integer in the range 0 - 7 if the speed is in the form of a

power of 2, and therefore may be stored in 3 bits, ii) a signal DI representing the direction of displacement of the pixel, which is calculated from the direction of maximum variation, the value of DI being also preferably represented by an integer in the range 0 - 7 corresponding to the Freeman code, stored in 3 bits, iii) a binary validation signal VL which indicates whether the result of the speed and oriented direction is valid, in order to be able to distinguish a valid output with $V = 0$ and $DI = 0$, from the lack of an output due to an incident, this signal being 1 for a valid output or 0 for an invalid output, iv) a time constant signal CO, stored in 3 bits, for example, and v) a delayed video signal SR consisting of the input video signal S delayed in the delay unit 18 by 16 consecutive line durations TR and therefore by the duration of the distribution of the signal S in the 17x 17 matrix 21, in order to obtain a video signal timed to matrix 21, which may be displayed on a television set or monitor. Also output are the clock signal HP, line sequence signal SL and column sequence signal SC from control unit 19.

Nested hexagonal matrices (Fig 8) or an inverted L-shaped matrix (Fig. 9) may be substituted for the nested rectangular matrices in Figs. 4 and 7. In the case shown in Fig. 8, the nested matrices (in which only the most central matrices MRI and MR2 have been shown) are all centered on point MR0 which corresponds to the central point of matrices M3, M9 in Fig. 7. The advantage of a hexagonal matrix system is that it allows the use of oblique coordinate axes x_1, y_1 , and a breakdown into triangles with identical sides, to carry out an isotropic speed calculation.

The matrix in Fig. 9 is composed of a single row (L_u) and a single column (C_u) starting from the central position MR_u in which the two signals DP and CO respectively are equal to "1" for DP and increase or decrease by one unit for CO, if movement occurs.

If movement is in the direction of the x coordinate, the CO signal is identical in all positions (boxes) in column C_u , and the binary signal DP is equal to 1 in all positions in row L_u , from the origin MR_u , with the value CO_u , up to the position in which CO is equal to $CO_u + 1$ or -1 inclusive. If movement is in the direction of the y coordinate, the CO signal is identical in all positions (boxes) in row L_u , and the binary signal DP is equal to 1 in all positions in column C_u , from the origin MR_u , with the value CO_u , up to the

position in which CO is equal to $CO_u + 1$ or -1 inclusive. If movement is oblique relative to the x and y coordinates, the binary signal DP is equal to 1 and CO is equal to CO_u in positions (boxes) of L_u and in positions (boxes) of C_u , the slope being determined by the perpendicular to the line passing through the two positions in which the signal CO_u changes by the value of one unit, the DP signal always being equal to 1.

Fig. 9 shows the case in which $DP = 1$ and CO_u changes value by one unit in the two specific positions L_{u3} and C_{u3} and indicates the corresponding slope P_p . In all cases, the displacement speed is a function of the position in which CO changes value by one unit. If CO changes by one unit in L_u or C_u only, it corresponds to the value of the CO variation position. If CO changes by one unit in a position in L_u and in a position in C_u , the speed is proportional to the distance between MR_u and E_x (intersection of the line perpendicular to $C_u - L_u$ passing through MR_u).

Fig. 10 shows an imaging device with sensors located at the intersections of concentric lines c and radial lines d that correspond to the rows and columns of a rectangular matrix imaging device. The operation of such an imaging device is controlled by a circular scanning sequencer. In this embodiment, angular sector shaped n x n matrices MC are formed, (a 3x3 matrix MC3 and a 5x5 matrix MC5 are shown) and except for sequencing differences, the matrices are processed identical to the square matrix embodiments discussed above.

As shown in Figs. 11-16, spatial and temporal processing unit 11 is used in connection with a histogram processor 22a for identifying objects within the input signal based upon user specified criteria for identifying such objects. A bus Z-Z₁ (See Figs. 2, 11 and 12) transfers the output signals of spatial and temporal processing unit 11 to histogram processor 22a. Histogram processor 22a generates composite output signal ZH which contains information on the areas in relative movement in the scene.

Referring to Fig. 12, histogram processor 22a includes a bus 23 for communicating signals between the various components thereof, for receiving input commands from a controller 42 and for transmitting output signals to controller 42. Histogram formation and processing blocks 24 - 29 receive the various input signals, i.e., delayed digital video signal SR, speed V, oriented directions (in Freeman code) DI, time

constant CO, first axis x(m) and second axis y(m), which are discussed in detail below. The function of each histogram formation block is to enable a histogram to be formed for the domain associated with that block. For example, histogram formation block 24 receives the delayed digital video signal SR and enables a histogram to be formed for the luminance values of the video signal. Since the luminance of the signal will generally be represented by a number in the range of 0-255, histogram formation block 24 is preferably a memory addressable with 8 bits, with each memory location having a sufficient number of bits to correspond to the number of pixels in a frame.

Histogram formation block 25 receives speed signal V and enables a histogram to be formed for the various speeds present in a frame. In a preferred embodiment, the speed is an integer in the range 0-7. Histogram formation block 25 is then preferably a memory addressable with 3 bits, with each memory location having a sufficient number of bits to correspond to the number of pixels in a frame.

Histogram formation block 26 receives oriented direction signal DI and enables a histogram to be formed for the oriented directions present in a frame. In a preferred embodiment, the oriented direction is an integer in the range 0-7, corresponding to the Freeman code. Histogram formation block 26 is then preferably a memory addressable with 3 bits, with each memory location having a sufficient number of bits to correspond to the number of pixels in a frame.

Histogram formation block 27 receives time constant signal CO and enables a histogram to be formed for the time constants of the pixels in a frame. In a preferred embodiment, the time constant is an integer in the range 0-7. Histogram formation block 27 is then preferably a memory addressable with 3 bits, with each memory location having a sufficient number of bits to correspond to the number of pixels in a frame.

Histogram formation blocks 28 and 29 receive the x and y positions respectively of pixels for which a histogram is to be formed, and form histograms for such pixels, as discussed in greater detail below. Histogram formation block 28 is preferably addressable with the number of bits corresponding to the number of pixels in a line, with each memory location having a sufficient number of bits to correspond to the number of lines in a frame, and histogram formation block 29 is preferably addressable with the

number of bits corresponding to the number of lines in a frame, with each memory location having a sufficient number of bits to correspond to the number of pixels in a line.

Referring to Figs. 12 and 14, each of the histogram formation blocks 24 - 29 has an associated validation block 30 - 35 respectively, which generates a validation signal V1 - V6 respectively. In general, each of the histogram formation blocks 24-29 is identical to the others and functions in the same manner. For simplicity, the invention will be described with respect to the operation of histogram formation block 25, it being appreciated that the remaining histogram formation blocks operate in a like manner. Histogram formation block 25 includes a histogram forming portion 25a, which forms the histogram for that block, and a classifier 25b, for selecting the criteria of pixels for which the histogram is to be formed. Histogram forming portion 25a and classifier 25b operate under the control of computer software in an integrated circuit (not shown), to extract certain limits of the histograms generated by the histogram formation block, and to control operation of the various components of the histogram formation units.

Referring to Fig. 14, histogram forming portion 25a includes a memory 100, which is preferably a conventional digital memory. In the case of histogram formation block 25 which forms a histogram of speed, memory 100 is sized to have addresses 0-7, each of which may store up to the number of pixels in an image. Between frames, memory 100 is initiated, i.e., cleared of all memory, by setting *init*=1 in multiplexors 102 and 104. This has the effect, with respect to multiplexor 102 of selecting the "0" input, which is output to the Data In line of memory 100. At the same time, setting *init*=1 causes multiplexor 104 to select the Counter input, which is output to the Address line of memory 100. The Counter input is connected to a counter (not shown) that counts through all of the addresses for memory 100, in this case $0 \leq \text{address} \leq 7$. This has the effect of placing a zero in all memory addresses of memory 100. Memory 100 is preferably cleared during the blanking interval between each frame. After memory 100 is cleared, the *init* line is set to zero, which in the case of multiplexor 102 results in the content of the Data line being sent to memory 100, and in the case of multiplexor 104 results in the data from spatial processing unit 117, i.e., the V data, being sent to the Address line of memory 100.

Classifier 25b enables only data having selected classification criteria to be considered further, meaning to possibly be included in the histograms formed by histogram formation blocks 24-29. For example, with respect to speed, which is preferably a value in the range of 0-7, classifier 25b may be set to consider only data within a particular speed category or categories, e.g., speed 1, speeds 3 or 5, speed 3-6, etc. Classifier 25b includes a register 106 that enables the classification criteria to be set by the user, or by a separate computer program. By way of example, register 106 will include, in the case of speed, eight registers numbered 0-7. By setting a register to "1", e.g., register number 2, only data that meets the criteria of the selected class, e.g., speed 2, will result in a classification output of "1". Expressed mathematically, for any given register in which $R(k) = b$, where k is the register number and b is the boolean value stored in the register:

$$\text{Output} = R(\text{data}(V))$$

So for a data point V of magnitude 2, the output of classifier 25b will be "1" only if $R(2)=1$. The classifier associated with histogram formation block 24 preferably has 256 registers, one register for each possible luminance value of the image. The classifier associated with histogram formation block 26 preferably has 8 registers, one register for each possible direction value. The classifier associated with histogram formation block 27 preferably has 8 registers, one register for each possible value of CO. The classifier associated with histogram formation block 28 preferably has the same number of registers as the number of pixels per line. Finally, the classifier associated with histogram formation block 29 preferably has the same number of registers as the number of lines per frame. The output of each classifier is communicated to each of the validation blocks 30-35 via bus 23, in the case of histogram formation blocks 28 and 29, through combination unit 36, which will be discussed further below.

Validation units 30-35 receive the classification information in parallel from all classification units in histogram formation blocks 24 - 29. Each validation unit generates a validation signal which is communicated to its associated histogram formation block 24 - 29. The validation signal determines, for each incoming pixel, whether the histogram formation block will utilize that pixel in forming its histogram. Referring again to Fig. 14,

which shows histogram formation block 25, validation unit 31 includes a register block 108 having a register associated with each histogram formation block, or more generally, a register associated with each data domain that the system is capable of processing, in this case, luminance, speed, direction, CO, and x and y position. The content of each register in register block 108 is a binary value that may be set by a user or by a computer controller. Each validation unit receive via bus 23 the output of each of the classifiers, in this case numbered 0 ... p, keeping in mind that for any data domain, e.g., speed, the output of the classifier for that data domain will only be "1" if the particular data point being considered is in the class of the registers set to "1" in the classifier for that data domain. The validation signal from each validation unit will only be "1" if for each register in the validation unit that is set to "1", an input of "1" is received from the classifier for the domain of that register. This may be expressed as follows:

$$out = (\overline{in_0 + Reg_0}) \cdot (\overline{in_1 + Reg_1}) \dots (\overline{in_n + Reg_n}) (in_0 + in_1 + \dots in_n)$$

where Reg_0 is the register in the validation unit associated with input in_0 . Thus, using the classifiers in combination with validation units 30 - 35, the system may select for processing only data points in any selected classes within any selected domains. For example, the system may be used to detect only data points having speed 2, direction 4, and luminance 125 by setting each of the following registers to "1": the registers in the validation units for speed, direction, and luminance, register 2 in the speed classifier, register 4 in the direction classifier, and register 125 in the luminance classifier. In order to form those pixels into a block, the registers in the validation units for the x and y directions would be set to "1" as well.

Referring again to Fig. 13, validation signal V2 is updated on a pixel-by-pixel basis. If, for a particular pixel, validation signal V2 is "1", adder 110 increments the output of memory 100 by one. If, for a particular pixel, validation signal V2 is "0", adder 100 does not increments the output of memory. In any case, the output of adder 100 is stored in memory 100 at the address corresponding to the pixel being considered. For example, assuming that memory 100 is used to form a histogram of speed, which may be categorized as speeds 0-7, and where memory 100 will include 0-7 corresponding memory locations, if a pixel with speed 6 is received, the address input to

5 multiplexor 104 through the data line will be 6. Assuming that validation signal V2 is "1", the content in memory at location 6 will be incremented. Over the course of an image, memory 100 will contain a histogram of the pixels for the image in the category associated with the memory. If, for a particular pixel, validation signal V2 is "0" because that pixel is not in a category for which pixels are to be counted (e.g., because that pixel does not have the correct direction, speed, or luminance), that pixel will not be used in forming the histogram.

10 For the histogram formed in memory 100, key characteristics for that histogram are simultaneously computed in a unit 112. Referring to Fig. 14, unit 112 includes memories for each of the key characteristics, which include the minimum (MIN) of the histogram, the maximum (MAX) of the histogram, the number of points (NBPTS) in the histogram, the position (POSRMAX) of the maximum of the histogram, and the number of points (RMAX) at the maximum of the histogram. These characteristics are determined in parallel with the formation of the histogram as follows:

15 For each pixel with a validation signal V2 of "1":

- (a) if the data value of the pixel < MIN (which is initially set to the maximum possible value of the histogram), then write data value in MIN;
- (b) if the data value of the pixel > MAX (which is initially set to the minimum possible value of the histogram), then write data value in MAX;
- 20 (c) if the content of memory 100 at the address of the data value of the pixel > RMAX (which is initially set to the minimum possible value of the histogram), then i) write data value in POSRMAX and ii) write the memory output in RMAX.
- (d) increment NBPTS (which is initially set to zero).

25 At the completion of the formation of the histogram in memory 100 at the end of each frame, unit 112 will contain important data characterizing the histogram. The histogram in each memory 100, and the characteristics of the histogram in units 112 are read during the scanning spot of each frame by controller 42, and the memories 100 are cleared and units 112 are re-initialized for processing the next frame.

30 The system of the invention includes a semi-graphic masking function to select pixels to be considered by the system. Fig. 16 shows a typical image 53 consisting of

pixels arranged in a $Q \times R$ matrix, which is divided into sub-matrices 51 each having a dimension of $s \times t$, wherein each $s \times t$ sub-matrix includes $s \times t$ number of pixels of the image. Each sub-matrix shown in Fig. 17 is a 3×4 matrix. In a preferred embodiment, $s=9$ and $t=12$, although any appropriate sub-matrix size may be used, if desired, including 1×1 . Referring to Fig. 12, histogram processor 22a includes a semi-graphic memory 50, which includes a one-bit memory location corresponding to each $s \times t$ matrix. For any given sub-matrix 51, the corresponding bit in memory 50 may be set to "0", which has the effect of ignoring all pixels in such sub-matrix 50, or may be set to "1" in which case all pixels in such sub-matrix will be considered in forming histograms. Thus, by using semi-graphic memory 50, it is possible to limit those areas of the image to be considered during histogram formation. For example, when an image of a road taken by a camera facing forward on a vehicle is used to detect the lanes of the road, the pixel information of the road at the farthest distances from the camera generally does not contain useful information. Accordingly, in such an application, the semi-graphic memory is used to mask off the distant portions of the road by setting semi-graphic memory 50 to ignore such pixels. Alternatively, the portion of the road to be ignored may be masked by setting the system to track pixels only within a detection box that excludes the undesired area of the screen, as discussed below.

In operation, for any pixel under consideration, an AND operation is run on the validation signal for such pixel and the content of semi-graphic memory 50 for the sub-matrix in which that pixel is located. If the content of semi-graphic memory 50 for the sub-matrix in which that pixel is located contains "0", the AND operation will yield a "0" and the pixel will be ignored, otherwise the pixel will be considered in the usual manner. It is foreseen that the AND operation may be run on other than the validation signal, with the same resultant functionality. Also, it is foreseen that memory 50 may be a frame size memory, with each pixel being independently selectable in the semi-graphic memory. This would enable any desired pixels of the image to be considered or ignored as desired. Semi-graphic memory 50 is set by controller 42 via data bus 23.

Fig. 16 shows an example of the successive classes $C_1, C_2 \dots C_{n-1}, C_n$, each representing a particular velocity, for a hypothetical velocity histogram, with their being

categorization for up to 16 velocities (15 are shown) in this example. Also shown is envelope 38, which is a smoothed representation of the histogram.

In order to locate the position of an object having user specified criteria within the image, histogram blocks 28 and 29 are used to generate histograms for the x and y positions of pixels with the selected criteria. These are shown in Fig. 13 as histograms
5 along the x and y coordinates. These x and y data are output to moving area formation block 36 which combines the abscissa and ordinate information $x(m)_2$ and $y(m)_2$ respectively into a composite signal $xy(m)$ that is output onto bus 23. A sample composite histogram 40 is shown in Fig. 13. The various histograms and composite
10 signal $xy(m)$ that are output to bus 23 are used to determine if there is a moving area in the image, to localize this area, and/or to determine its speed and oriented direction. Because the area in relative movement may be in an observation plane along directions x and y which are not necessarily orthogonal, as discussed below with respect to Fig. 18, a data change block 37 may be used to convert the x and y data to orthogonal coordinates.
15 Data change block 37 receives orientation signals $x(m)_1$ and $y(m)_1$ for $x(m)_0$ and $y(m)_0$ axes, as well as pixel clock signals HP, line sequence and column sequence signals SL and SC (these three signals being grouped together in bundle F in Figs. 2, 4, and 10) and generates the orthogonal $x(m)_1$ and $y(m)_1$ signals that are output to histogram formation blocks 28 and 29 respectively.

20 In order to process pixels only within a user-defined area, the x-direction histogram formation unit 28 may be programmed to process pixels only in a class of pixels defined by boundaries, i.e. XMIN and XMAX. This is accomplished by setting the XMIN and XMAX values in a user-programmable memory in x-direction histogram formation unit 28 or in linear combination units 30-35. Any pixels outside of this class
25 will not be processed. Similarly, y-direction histogram formation unit 29 may be set to process pixels only in a class of pixels defined by boundaries YMIN and YMAX. This is accomplished by setting the YMIN and YMAX values in a user-programmable memory in y-direction histogram formation unit 29 or in linear combination units 30-35. Thus, the system can process pixels only in a defined rectangle by setting the XMIN and
30 XMAX, and YMIN and YMAX values as desired. Of course, the classification criteria

and validation criteria from the other histogram formation units may be set in order to form histograms of only selected classes of pixels in selected domains within the selected rectangular area. The XMIN and XMAX memory locations have a sufficient number of bits to represent the maximum number of pixels in the x dimension of the image under consideration, and the YMIN and YMAX memory locations have a sufficient number of bits to represent the maximum number of pixels in the y dimension the image under consideration. As discussed further below, the x and y axes may be rotated in order to create histograms of projections along the rotated axes. In a preferred embodiment, the XMIN, XMAX, YMIN and YMAX memory locations have a sufficient number of bits to represent the maximum number of pixels along the diagonal of the image under consideration (the distance from "Origin" to "Stop" in Fig. 15). In this way, the system may be used to search within a user-defined rectangle along a user-defined rotated axis system.

In order for a pixel $PI(a,b)$ to be considered in the formation of x and y direction histograms, whether on the orthogonal coordinate axes or along rotated axes, the conditions $XMIN < a < XMAX$ and $YMIN < b < YMAX$ must be satisfied. The output of these tests may be ANDed with the validation signal so that if the conditions are not satisfied, a logical "0" is ANDed with the validation signal for the pixel under consideration, thereby avoiding consideration of the pixel in the formation of x and y direction histograms.

Fig. 13 diagrammatically represents the envelopes of histograms 38 and 39, respectively in x and y coordinates, for velocity data. In this example, x_M and y_M represent the x and y coordinates of the maxima of the two histograms 38 and 39, whereas l_a and l_b for the x axis and l_c and l_d for the y axis represent the limits of the range of significant or interesting speeds, l_a and l_c being the longer limits and l_b and l_d being the upper limited of the significant portions of the histograms. Limits l_a , l_b , l_c and l_d may be set by the user or by an application program using the system, may be set as a ratio of the maximum of the histogram, e.g., $x_M/2$, or may be set as otherwise desired for the particular application.

The vertical lines L_a and L_b of abscissas l_a and l_b and the horizontal lines L_c and L_d of ordinates l_c and l_d form a rectangle that surrounds the cross hatched area 40 of significant speeds (for all x and y directions). A few smaller areas 41 with longer speeds, exist close to the main area 40, and are typically ignored. In this example, all that is necessary to characterize the area with the largest variation of the parameter for the histogram, the speed V in this particular case, is to identify the coordinates of the limits l_a , l_b , l_c and l_d and the maxima X_M and Y_M , which may be readily derived for each histogram from memory 100, the data in units 112, and the $xy(m)$ data block.

Thus, the system of the invention generates in real time, histograms of each of the parameters being detected. Assuming that it were desired to identify an object with a speed of "2" and a direction of "4", the validation units for speed and direction would be set to "1", and the classifiers for speed "2" and direction "4" would be set to "1". In addition, since it is desired to locate the object(s) with this speed and direction on the video image, the validation signals for histogram formation blocks 28 and 29, which correspond to the x and y coordinates, would be set to "1" as well. In this way, histogram formation blocks 28 and 29 would form histograms of only the pixels with the selected speed and direction, in real-time. Using the information in the histogram, and especially POSRMAX, the object with the greatest number of pixels at the selected speed and direction could be identified on the video image in real-time. More generally, the histogram formation blocks can localize objects in real-time meeting user-selected criteria, and may produce an output signal if an object is detected. Alternatively, the information may be transmitted, e.g., by wire, optical fiber or radio relay for remote applications, to a control unit, such as unit 10a in Fig. 1, which may be near or remote from spatial and temporal processing unit 11.

While the system of the invention has been described with respect to formation of histograms using an orthogonal coordinate system defined by the horizontal and vertical axes of the video image, the system may be used to form histograms using non-orthogonal axes that are user-defined. Figs. 15A and 15B show a method of using rotation of the analysis axis to determine the orientation of certain points in an image, a method which may be used, for example to detect lines. In a preferred embodiment, the

x-axis may be rotated in up to 16 different directions ($180^\circ/16$), and the y-axis may be independently rotated by up to 16 different directions. Rotation of the axes is accomplished using data line change block 37 which receives as an input the user-defined axes of rotation for each of the x and y axes, and which performs a Hough transform to convert the x and y coordinate values under consideration into the rotated coordinate axis system for consideration by the x and y histogram formation units 28 and 29. The operation of conversion between coordinate systems using a Hough transform is known in the art. Thus, the user may select rotation of the x-coordinate system in up to 16 different directions, and may independently rotate the y-coordinate system in up to 16 different directions. Using the rotated coordinate systems, the system may perform the functionality described above, including searching within user-defined rectangles (on the rotated axes), forming histograms on the rotated axes, and searching using velocity, direction, etc.

As discussed above, each histogram formation unit calculates the following values for its respective histogram.

MIN, MAX, NBPTS, RMAX, POSRMAX

Given that these values are calculated in real-time, the use of these values allows the system to rapidly identify lines on an image. While this may be accomplished in a number of different ways, one of the easier methods is to calculate R, where $R = \text{NBPTS}/\text{RMAX}$, i.e., the ratio of the number of points in the histogram to the number of points in the maximal line. The smaller this ratio, i.e., the closer R approaches 1, the more perpendicularly aligned the data points under consideration are with the scanning axis.

Fig. 15A shows a histogram of certain points under consideration, where the histogram is taken along the x-axis, i.e., projected down onto the x-axis. In this example, the ratio R, while not calculated, is high, and contains little information about the orientation of the points under consideration. As the x-axis is rotated, the ratio R increases, until, as shown in Fig. 15B, at approximately 45° the ratio R would reach a maximum. This indicates that the points under consideration are most closely aligned perpendicular to the 45° x-axis. In operation, on successive frames, or on the same

frame if multiple x-direction histogram formation units are available, it is advantageous to calculate R at different angles, e.g., 33.75° and 57.25° (assuming the axes are limited to 16 degrees of rotation), in order to constantly ensure that R is at a minimum. For applications in which it is desirable to detect lines, and assuming the availability of 16 x-direction histogram formation units, it is advantageous to carry out the calculation of R simultaneously along all possible axes to determine the angle with the minimum R to determine the direction of orientation of the line. Because the x and y axes may be rotated independently, the x and y histogram formation units are capable of simultaneously independently detecting lines, such as each side line of a road, in the same manner.

As discussed above, the system of the invention may be used to search for objects within a bounded area defined by XMIN, XMAX, YMIN and YMAX. Because moving object may leave the bounded area the system preferably includes an anticipation function which enables XMIN, XMAX, YMIN and YMAX to be automatically modified by the system to compensate for the speed and direction of the target. This is accomplished by determining values for O-MVT, corresponding to orientation (direction) of movement of the target within the bounded area using the direction histogram, and I-MVT, corresponding to the intensity (velocity) of movement. Using these parameters, controller 42 may modify the values of XMIN, XMAX, YMIN and YMAX on a frame-by-frame basis to ensure that the target remains in the bounded box being searched. These parameters also enable the system to determine when a moving object, e.g., a line, that is being tracked based upon its axis of rotation, will be changing its axis of orientation, and enable the system to anticipate a new orientation axis in order to maintain a minimized value of R.

Referring to Fig. 12, a controller 42, which is preferably a conventional microprocessor-based controller, is used to control the various elements of the system and to enable user input of commands and controls, such as with a computer mouse and keyboard (not shown), or other input device. Components 11a and 22a, and controller 42, are preferably formed on a single integrated circuit. Controller 42 is in communication with data bus 23, which allows controller 42 to run a program to control

various parameters that may be set in the system and to analyze the results. In order to select the criteria of pixels to be tracked, controller 42 may also directly control the following: i) content of each register in classifiers 25b, ii) the content of each register in validation units 31, iii) the content of XMIN, XMAX, YMIN and YMAX, iv) the orientation angle of each of the x and y axes, and v) semi-graphic memory 50. Controller 42 may also retrieve i) the content of each memory 100 and ii) the content of registers 112, in order to analyze the results of the histogram formation process. In addition, in general controller 42 may access and control all data and parameters used in the system.

10 The system of the invention may be used to detect the driver of a vehicle falling asleep and to generate an alarm upon detection thereof. While numerous embodiments of the invention will be described, in general the system receives an image of the driver from a camera or the like and processes the image to detect one or more criteria of the eyes of the driver to determine when the driver's eyes are open and when they are closed. As discussed above, a wide-awake person generally blinks at relatively regular intervals of about 100 to 200 ms. When a person becomes drowsy, the length of each eye blink increases to approximately 500 to 800 ms, with the intervals between blinks becoming longer and variable. Using the information on the opening and closing of the driver's eyes, the system measures the duration of each blink and/or the intervals between blinks to determine when the driver is falling asleep. This is possible because the video signal coming from the sensor in use, e.g., sensor 310 of Fig. 21, preferably generates 50 or 60 frames per second, i.e., a frame every 20 ms or 16.66 ms respectively. This makes it possible for the system, which processes each image in real time, to distinguish between blink lengths of 100 to 200 ms for an awake person from blink lengths of 500 to 800 ms for a drowsy person, i.e., a blink length of 5 to 10 frames for an awake person or a blink length of 25 to 40 frames for a drowsy person, in the case of a 50 frames per second video signal.

 The system of the invention utilizes a video camera or other sensor to receive images of the driver T in order to detect when the driver is falling asleep. While various methods of positioning the sensor shall be described, the sensor may generally be

position by any means and in any location that permits acquisition of a continuous image of the face of the driver when seated in the driver's seat. Thus, it is foreseen that sensor 10 may be mounted to the vehicle or on the vehicle in any appropriate location, such as in or on the vehicle dashboard, steering wheel, door, rear-view mirror, ceiling, etc., to enable sensor 10 to view the face of the driver. An appropriate lens may be mounted on the sensor 10 to give the sensor a wider view if required to see drivers of different sizes.

Figs. 18 and 19 show a conventional rear-view mirror arrangement in which a driver T can see ahead along direction 301 and rearward (via rays 302a and 302b) through a rear-view mirror 303. Referring to Fig. 20, mirror 303 is attached to the vehicle body 305 through a connecting arm 304 which enables adjustment of vision axes 302a and 302b. Axes 302a and 302b are generally parallel and are oriented in the direction of the vehicle. Optical axis 306, which is perpendicular to the face 303a of mirror 303, divides the angle formed by axes 302a and 302b into equal angles a and b. Axis 307, which is perpendicular to axis 302b and therefore generally parallel to the attachment portion of vehicle body 305, defines an angle c between axis 307 and mirror face 303a which is generally equal to angles a and b. A camera or sensor 310 is preferably mounted to the mirror by means of a bracket 299. The camera may be mounted in any desired position to enable the driver to have a clear view of the road while enabling sensor 310 to acquire images of the face of the driver. Bracket 299 may be an adjustable bracket, enabling the camera to be faced in a desired direction, i.e., toward the driver, or may be at a fixed orientation such that when the mirror is adjusted by drivers of different sizes, the camera continues to acquire the face of the driver. The signal from the camera is communicated to the image processing system, which operates as described below, by means of lead wires or the like (not shown in Figs. 18-20).

Figs. 21 and 22 show a rear-view mirror assembly 308 in which sensor 310 is mounted interior to the mirror assembly. Mirror assembly 308 is adapted so that as assembly 308 is adjusted by a driver, sensor 310 remains directed toward the face of the driver. Rear-view mirror assembly 308 includes a two-way mirror 309 having a face 309a, movably oriented to provide a rear view to the driver. Sensor 310, which is preferably an electronic mini-camera or MOS sensor with a built-in lens, is affixed to a

5 bracket 311, is oriented facing the driver using mechanical arrangement that enables sensor 310 to receive an image of the face of the driver when mirror 309 adjusted so that the driver has a rear view of the vehicle. The mechanical arrangement consists of a Cardan type mechanical joint, which causes automatic adjustment of the bracket 311 when the driver when the driver adjusts the rear view mirror so that the receiving face 310a of sensor 310 receives the image of the face of the driver, i.e., optical axis 310b remains aligned toward the head of the driver.

10 Bracket 311 includes rods 312 and 313 that are movably coupled together by a pivot pin 314a (Fig. 21) or a sleeve 314b (Fig. 22). Rod 312 is attached at one end to a mounting portion of the vehicle 305. A pivot pin 315, which preferably consists of a ball and two substantially hemispherical caps, facilitates movement of mirror assembly 308. Rod 312 extends through pivot pin 315, and attaches to rod 313 via a sleeve 314b or another pivot pin 314a. At one end, rod 313 rigidly supports bracket 311 on which sensor 310 is mounted. Rod 313 extends through clamp 316 of mirror assembly 308 via
15 a hollow pivot 317. Pivot 317 includes a ball having a channel therethrough in which rod 313 is engaged, and which rotates in substantially hemispherical caps supported by clamp 316. The joint constantly maintains a desired angle between mirror 309 and bracket 311, thereby permitting normal adjustment of rear-view mirror 309 while bracket 311 adjusts the direction of sensor 310 so that the face 310a of the sensor will receive an image of
20 the face of the driver. If desired, it is foreseen that sensor 310 may be mounted interior to rear-view mirror assembly 308 at a fixed angle relative to the face 309a of the mirror assembly, provided that sensor 310 is able to receive an image of the face of the driver when the mirror is adjusted to drivers of different sizes. A wide angle lens may be mounted to sensor 310 to better enable the sensor to be used under different adjustment
25 circumstances.

Sensor 310 is connected by means of one or more lead wires to image processor 319, which is preferably an image processing system of the type discussed above and is preferably in the form of an integrated circuit inside rear-view mirror assembly 308. In a preferred embodiment, image processing system 319 is integrally constructed with sensor
30 310. Alternatively, image processing system 319 may be located exterior to mirror

assembly 308 by means of conventional lead wires. While controller 310 is preferably a microprocessor, it is foreseen that controller 310 may be an ASIC or simple controller designed to perform the functions specified herein, particularly if the system is embedded, e.g. contained in a mirror assembly or integral with a vehicle.

5 Electroluminescent diodes 320 may be incorporated in mirror assembly 308 to illuminate the face of the driver with infrared radiation when ambient light is insufficient for image processing system 319 to determine the blinking characteristics of the driver. When such diodes are in use, sensor 310 must be of the type capable of receiving infrared radiation. Illumination of electroluminescent diodes 320 may be controlled by
10 controller 42 (Fig. 12) of image processing system 319, if desired. For example, controller 42 may illuminate electroluminescent diodes 320 in the event that the histograms generated by image processing system 319 do not contain sufficient useful information to detect the features of the driver's face required, e.g., NBPTS is below a threshold. Electroluminescent diodes 320 may be illuminated gradually, if desired, and
15 may operate in connection with one or more photocells (not shown) that generate a signal as to the ambient lighting near the driver, and which may be used to control electroluminescent diodes 320, either alone or in combination with controller 42 or another control circuit. If desired, an IR or other source of EMF radiation may be used to illuminate the face of the driver at all times, provided that sensor 310 is compatible
20 with the illumination source. This eliminates many problems that may be associated with the use of ambient lighting to detect drowsiness.

 An optional alarm 322, which may be for example a buzzer, bell or other notification means, may be activated by controller 42 upon detecting that the driver is falling asleep. All of the components contained in mirror assembly 308, and image
25 processing system 319, are preferably powered by the electrical system of the vehicle.

 Image processing system 319 monitors the alertness of the driver by detecting, in real time and on a continuous basis, the duration of the blinks of the driver's eyes and/or intervals between blinks, and by triggering alarm 322 to wake up the driver in the event the driver is detected falling asleep. Image processing system 319 receives an image of
30 the face of the driver from sensor 310. The image may be of the complete face of the

driver, or of a selected area of the driver's face that includes at least one eye of the driver. Image processing system 319 is capable of detecting numerous criteria that are associated with blinking eyes. These include any feature of the face that may be used to discern the closing of an eye, including detection of the pupil, retina, white, eyelids, skin adjacent to the eye, and others. The eye may also be detected by detecting either
5 changes in the appearance of the eye when blinking or by detecting motion of the eyelid during blinking.

Referring to Fig. 30, as an initial step, the system of the invention preferably detects the presence of a driver in the driver's seat (402). This may be accomplished in
10 any number of ways, such as by an electrical weight sensor switch in the driver's seat or by interfacing with a signal generated by the vehicle indicating that the vehicle is in use in motion, e.g., a speed sensor, a switch detecting that the vehicle is in gear, a switch detecting that closing of the seat belt, etc. Upon detection of such a signal, the system enters into a search mode for detecting the driver's face or driver's eye(s). Alternatively,
15 since the system is powered by the electrical system of the vehicle, and more preferably by a circuit of the electrical system that is powered only when the vehicle is turned on, the system turns on only when the engine is turned on, and enters into a search mode in which it operates until the face or eye(s) of the driver are detected. Upon detection of a driver in the vehicle (404), a Driver Present flag is set to "1" so that controller 42 is
20 aware of the presence of the driver.

As an alternative method of detecting the presence of the driver, if sensor 10 is mounted in a manner that enables (or requires) that the sensor be adjusted toward the face of the driver prior to use, e.g., by adjustment of the rear-view mirror shown in Fig. 21, the system may activate an alarm until the sensor has acquired the face of the driver.

25 The driver may also be detected by using the image processing system to detect the driver entering the driver's seat. This assumes that the image processing system and sensor 10 are already powered when the driver enters the vehicle, such as by connecting the image processing system and sensor to a circuit of the vehicle electrical system that has constant power. Alternatively, the system may be powered upon detecting the
30 vehicle door open, etc. When the driver enters the driver's seat, the image from sensor

10 will be characterized by many pixels of the image being in motion (DP=1), with CO having a relatively high value, moving in a lateral direction away from the driver's door. The pixels will also have hue characteristics of skin. In this embodiment, in a mode in which the system is trying to detect the presence of the driver, controller 42 sets the validation units to detect movement of the driver into the vehicle by setting the histogram formation units to detect movement characteristic of a driver entering the driver's seat. Most easily, controller 42 may set the validation units to detect DP=1, and analyze the histogram in the histogram formation unit for DP to detect movement indicative of a person entering the vehicle, e.g., NBPTS exceeding a threshold.

10 Fig. 23 shows the field of view 323 of sensor 310 between directions 323a and 323b where the head T of the driver is within, and is preferably centered in, conical field 323. Field 323 may be kept relatively narrow, given that the movements of the head T of the driver during driving are limited. Limitation of field 23 improves the sensitivity of the system since the driver's face will be represented in the images received from sensor 15 10 by a greater number of pixels, which improves the histogram formation process discussed below.

In general the number of pixels in motion will depend upon the field of view of the sensor. The ratio of the number of pixels characteristic of a driver moving into the vehicle to the total number of pixels in a frame is a function of the size of the field of vision of the sensor. For a narrow field of view (a smaller angle between 323a and 323b in Fig. 23), a greater number, and possibly more than 50% of the pixels will be "in movement" as the driver enters the vehicle, and the threshold will be greater. For a wide field of view (a greater angle between 323a and 323b in Fig. 23), a smaller number of pixels will be "in movement" as the driver enters the vehicle. The threshold is set 25 corresponding to the particular location and type of sensor, and based upon other characteristics of the particular installation of the system. If NBPTS for the DP histogram exceeds the threshold, the controller has detected the presence of the driver.

As discussed above, other characteristics of the driver entering the vehicle may be detected by the system, including a high CO, hue, direction, etc., in any combinations, as 30 appropriate, to make the system more robust. For example, controller 42 may set the

linear combination units of the direction histogram formation unit to detect pixels moving into the vehicle, may set the linear combination unit for CO to detect high values, and/or may set the linear combination unit for hue to detect hues characteristic of human skin. Controller 42 may then set the validation units to detect DP, CO, hue, and/or direction, as appropriate. The resultant histogram may then be analyzed to determine whether NBPTS exceeds a threshold, which would indicate that the driver has moved into the driver's seat. It is foreseen that characteristics other than NBPTS of the resultant histogram may be used to detect the presence of the driver, e.g., RMAX exceeding a threshold.

10 When the driver has been detected, i.e., the Driver Present flag has been set to "1", the system detects the face of the driver in the video signal and eliminates from further processing those superfluous portions of the video signal above, below, and to the right and left of the head of the driver. In the image of the drivers head, the edges of the head are detected based upon movements of the head. The edges of the head will normally be characterized by DP=1 due to differences in the luminance of the skin and the background, even due to minimal movements of the head while the head is still. Movement of the head may be further characterized by vertical movement on the top and bottom edges of the head, and left and right movement on the vertical edges of the head. The pixels of the head in movement will also be characterized by a hue corresponding to human skin and relatively slow movement as compared to eyelid movement for example. Controller 42 preferably sets the linear combination unit of DP to detect DP=1 and sets the linear combination unit for direction to detect vertical and horizontal movement only (406). Optionally, the linear combination units for velocity and hue may be set to detect low velocities and human skin hues to make the system more robust. Also, the linear combination unit for CO may be set to eliminate the very fast movements characteristic of eye blinking in order to prevent the eyes from being considered at this stage of processing during which the head is being detected. Finally, controller 42 sets the validation units for DP, direction, and x and y position to be "on" (406). Optionally, the validation units for velocity, hue, and CO may be set "on" if these criteria are being detected.

As illustrated in Fig. 24, the pixels having the selected characteristics are formed into histograms 324x and 324y along axes Ox and Oy, i.e., horizontal and vertical projections, respectively. Slight movements of the head of the driver having the characteristics selected are indicated as ripples 327a, 327b, 327c and 327d, which are shown in line form but which actually extend over a small area surrounding the periphery of the head. Peaks 325a and 325b of histogram 324x, and 325c and 325d of histogram 324y delimit, by their respective coordinates 326a, 326b, 326c and 326d, a frame bounded by straight lines *Ya*, *Yb*, *Xc*, *Xd*, which generally correspond to the area in which the face V of the driver located. Controller 42 reads the histograms 324x and 324y from the histogram formation units, preferably during the blanking interval, and detects the locations of peaks 325a, 325b, 325c and 325d (408). In order to ensure that the head has been identified, the distance between peaks 325a and 325b and between peaks 325b and 325c are preferably tested to fall with a range corresponding to the normal ranges of human head sizes.

Once the location of coordinates 326a, 326b, 326c and 326d has been established, the area surrounding the face of the driver is masked from further processing (410). Referring to Fig. 25, this is accomplished by having controller 42 set XMIN, XMAX, YMIN and YMAX to correspond to *Xc*, *Xd*, *Ya*, and *Yb* respectively. This masks the cross-hatched area surrounding face V from further consideration, which helps to eliminate background movement from affecting the ability of the system to detect the eye(s) of the driver. Thus, for subsequent analysis, only pixels in central area Z, framed by the lines *Xc*, *Xd*, *Ya*, *Yb* and containing face V are considered. As an alternative method of masking the area outside central area Z, controller 42 may set the semi-graphic memory to mask off these areas. As indicated above, the semi-graphic memory may be used to mask off selected pixels of the image in individual or small rectangular groups. Since head V is not rectangular, use of the semi-graphic memory enables better masking around the rounded edges of the face to better eliminate background pixels from further consideration.

The process of detecting the head of the driver and masking background areas is repeated at regular intervals, and preferably once every ten frames or less. It is foreseen

that this process may be repeated every frame, if desired, particularly if more than one set of histogram formation units is available for use. Controller 42 may also compute average values over time for coordinates 326a, 326b, 326c and 326d and use these values to set mask coordinates X_c , X_d , Y_a , Y_b , if desired. This will establish a nearly
5 fixed position for the frame over time.

Once the frame has been established, a Centered-Face flag is set to "1" (412), and controller 42 initiates the process of reducing the frame size to more closely surround the eyes of the driver. Referring to Fig. 26, in which frame Z denotes the area bounded by Y_a , Y_b , X_c , X_d determined in the prior step, controller 42 initially uses the usual
10 anthropomorphic ratio between the zone of the eyes and the entire face for a human being, especially in the vertical direction, to reduce the area under consideration to cover a smaller zone Z' bounded by lines $Y'a$, $Y'b$, $X'c$ and $X'd$ that includes the eyes U of the driver. Thus, the pixels in the outer cross-hatched area of Fig. 27 is eliminated from consideration and only the area within frame Z' is further considered. This is
15 accomplished by having controller 42 set X_{MIN} , X_{MAX} , Y_{MIN} and Y_{MAX} to correspond to $X'c$, $X'd$, $Y'a$, and $Y'b$ respectively (414). This masks the pixels in the area outside Z' from further consideration. Thus, for subsequent analysis, only pixels in area Z' containing eyes U are considered. As an alternative method of masking the area outside area Z' , controller 42 may set the semi-graphic memory to mask off these areas.
20 It is foreseen that an anthropomorphic ratio may be used to set frame Z' around only a single eye, with detection of blinking being generally the same as described below, but for one eye only.

Once the area Z' is determined using the anthropomorphic ratio, a Rough Eye-Centering flag is set to "1" (416), and controller 42 performs the step of analyzing the
25 pixels within the area Z' to identify movement of the eyelids. Movement of eyelids is characterized by criteria that include high speed vertical movement of pixels with the hue of skin. In general, within the area Z' , formation of histograms for $DP=1$ may be sufficient to detect eyelid movement. This detection may be made more robust by detection of high values of CO , by detection of vertical movement, by detection of high
30 velocity, and by detection of hue. As an alternative to detection of hue, movement of the

pixels of the eye may be detected by detecting pixels with $DP=1$ that do not have the hue of skin. This will enable detection of changes in the number of pixels associated with the pupil, retina, iris, etc.

Controller 42 sets the linear combination unit for DP to detect $DP=1$ and sets the validation units for DP, and x and y position to be on (418). Optionally, the linear combination units and validation units may be set to detect other criteria associated with eye movement, such as CO, velocity, and hue. Initially, controller 42 also sets XMIN, XMAX, YMIN and YMAX to correspond to $X'c$, $X'd$, $Y'a$, and $Y'b$ respectively. Referring to Fig. 27, a histogram is formed of the selected criteria, which is analyzed by controller 42 (420). If desired, a test is performed to ensure that the eyes have been detected. This test may, for example, consist of ensuring that NBTS in the histogram exceeds a threshold e.g., 20% of the total number of pixels in the frame $Y'a$, $Y'b$, $X'c$, $X'd$. Once the eyes have been detected an Eye-Detected flag is set to "1" (422).

Fig. 27 illustrates histogram 28x along axis Ox and histogram 28y along axis Oy of the pixels with the selected criteria corresponding to the driver's eyelids, preferably $DP=1$ with vertical movement. Controller 42 analyzes the histogram and determines peaks 29a, 29b, 29c and 29d of the histogram. These peaks are used to determine horizontal lines $X''c$ and $X''d$ and vertical lines $Y''a$ and $Y''b$ which define an area of movement of the eyelids Z'' , the movements of the edges of which are indicated at 30a and 30b for one eye and 30c and 30d for the other eye (424). The position of the frame bounded by $Y''a$, $Y''b$, $X''c$, $X''d$ is preferably determined and updated by time-averaging the values of peaks 29a, 29b, 29c and 29d, preferably every ten frames or less. Once the eyes have been detected and frame Z'' has been established an Eye Centered flag is set to "1" (426) and only pixels within frame Z'' are thereafter processed.

Controller 42 then determines the lengths of the eye blinks, and, if applicable, the time interval between successive blinks. Fig. 28 illustrates in a three-dimensional orthogonal coordinate system: OQ, which corresponds to the number of pixels in area Z'' having the selected criteria; T_o , which corresponds to the time interval between successive blinks; and Oz which corresponds to the length of each blink. From this

information, it is possible to determine when a driver is falling asleep. Two successive blinks C1 and C2 are shown on Fig. 28.

Fig. 29A illustrates on curve C the variation over time of the number of pixels in each frame having the selected criteria, e.g., $DP = 1$, wherein successive peaks P1, P2, P3 correspond to successive blinks. This information is determined by controller 42 by reading NBPTS of the x and/or y histogram formation units. Alternatively, controller 42 may analyze the x and/or y histograms of the histogram formation units (Fig. 27) to detect peaks 29a and 29b and/or 29c and 29d, which over time will exhibit graph characteristics similar to those shown in Fig. 29A.

Controller 42 analyzes the data in Fig. 29A over time to determine the location and timing of peaks in the graph (428). This may be done, for example, as shown in Fig. 29B, by converting the graph shown in Fig. 29A into a binary data stream, in which all pixels counts over a threshold are set to "1", and all pixel counts below the threshold are set to "0" (vertical dashes 31), in order to convert peaks P1, P2, P3 to framed rectangles R1, R2 R3, respectively. Finally, Fig. 29B shows the lengths of each blink (5, 6, and 5 frames respectively for blinks P1, P2 and P3) and the time intervals (14 and 17 frames for the intervals between blinks P1 and P2, and P2 and P3 respectively). This information is determined by controller 42 through an analysis of the peak data over time.

Finally, controller 42 calculates the lengths of successive eye blinks and the interval between successive blinks (430). If the length of the blinks exceeds a threshold, e.g., 350 ms, a flag is set to "1" indicating that the blink threshold has been exceeded. If the time interval between successive blinks is found to vary significantly over time, a flag is set to "1" indicting a variable intervals between blinks. Upon setting the first flag, which indicates that the driver is blinking at a rate indicative of falling asleep, controller 42 triggers alarm 322 for waking up the driver. The second flag may be used either to generate an alarm in the same manner as with the first flag, or to reinforce the first flag to, for example, increase the alarm sound level.

Figs. 31 - 36 show an alternative method by which the generic image processing system may be used to detect a driver falling asleep. Initially, controller 42 is placed in a search mode (350), in which controller 42 is scans the image to detect one or more

characteristics of the face, and preferably the nostrils of the nose. Nostrils are generally shadowed, and as such are usually defined by low luminance. Referring to Fig. 31, the area of the image is broken up into a number of sub-images 352, in this case six, labelled A-F, which are sequentially analyzed by controller 42 to locate the nostrils. As shown, each of the sub-images 352 preferably overlaps each adjacent sub-image by an amount 353 equal to at least the normal combined width of the nostrils and the spacing therebetween to minimize the likelihood of missing the nostrils while in the search mode.

Controller 42 sets XMIN, XMAX, YMIN, and YMAX to correspond to the first sub-image A (354). Controller 42 then sets the registers 106 in the luminance linear combination unit to detect low luminance levels (356). The actual luminance level selected will vary depending upon various factors, such as ambient lighting, time of day, weather conditions, etc. Keeping in mind that controller 42 is able to access the histogram calculated for luminance from histogram formation unit 24, controller 42 may use a threshold or other desired technique to select the desired luminances to search for the nostrils, e.g., selecting the lowest 15% of luminance values for consideration, and may adapt the threshold as desired. Controller 42 also sets the validation units for luminance and x and y histogram on (358), thereby causing x and y histograms to be formed of the selected low luminance levels. Controller 42 then analyzes the x and y direction histograms to identify characteristics indicative of the nostrils, as discussed below (360). If nostrils are not identified (362), controller 42 repeats this process on the next sub-image, i.e., sub-image B, and each subsequent sub-image, until nostrils are identified, repeating the process starting with sub-image A if required. Each sub-image is analyzed by controller 42 in a single frame. Accordingly, the nostrils may generally be acquired by the system in less than six frames. It is foreseen that additional sub-images may be used, if desired. It is also foreseen that the area in which the sub-images are searched may be restricted to an area in which the nostrils are most likely to be present, either as determined from past operation of the system, or by use of an anthropomorphic model. For example, the outline of the head of the driver may be determined as described above, and the nostril search may then be restricted to a small sub-area of the

image. It is also foreseen that the entire image may be search at once for the nostrils, if desired.

While the invention is being described with respect to identification of the nostrils as a starting point to locating the eyes, it is foreseen that any other facial characteristic, e.g., the nose, ears, eyebrows, mouth, etc., and combinations thereof, may be detected as a starting point for locating the eyes. These characteristics may be discerned from any characteristics capable of being searched by the system, including CO, DP, velocity, direction, luminance, hue and saturation. It is also foreseen that the system may locate the eyes directly, e.g., by simply searching the entire image for DP=1 with vertical movement (or any other searchable characteristics of the eye), without the need for using another facial criteria as a starting point. In order to provide a detailed view of the eye while enabling detection of the head or other facial characteristic of the driver, it is foreseen that separate sensors may be used for each purpose.

Fig. 32 shows sample x and y histograms of a sub-image in which the nostrils are located. Nostrils are characterized by a peak 370 in the y-direction histogram, and two peaks 372 and 374 in the x-direction histogram. Confirmation that the nostrils have been identified may be accomplished in several ways. First, the histograms are analyzed to ensure that the characteristics of each histogram meets certain conditions. For example, NBPTS in each histogram should exceed a threshold associated with the normal number of pixels detectable for nostrils. Also, RMAX in the y histogram, and each peak of the x histogram should exceed a similar threshold. Second, the distance between nostrils d is fairly constant. The x histogram is analyzed by controller 42 and d is measured to ensure that it falls within a desired range. Finally, the width of a nostril is also fairly constant, although subject to variation due to shadowing effects. Each of the x and y histograms is analyzed by controller 42 to ensure that the dimensions of each nostril fall within a desired range. If the nostrils are found by controller 42 to meet these criteria, the nostrils have been acquired and the search mode is ended. If the nostrils have not been acquired, the search mode is continued. Once the nostrils are acquired, the x position of the center of the face (position $d/2$ within the sub- image under consideration) is

determined, as is the y location of the nostrils in the image (POSRMAX of the y histogram) (364).

In the present example, only a single eye is analyzed to determine when the driver is falling asleep. In this case the shadow of the eye in the open and closed positions is used to determine from the shape of the shadow whether the eye is open or closed. As discussed above, for night-time applications, the invention is preferably used in combination with a short-wave IR light source. For the presently described example, the IR light source is preferably positioned above the driver at a position to cast a shadow having a shape capable of detected by the system. The anthropomorphic model is preferably adaptive to motion, to features of the driver, and to angular changes of the driver relative to the sensor.

Referring to Fig. 32, having determined the location of the nostrils 272 of the driver having a center position X_N , Y_N , a search box 276 is established around an eye 274 of the driver (366). The location of search box 276 is set using an anthropomorphic model, wherein the spatial relationship between the eyes and nose of humans is known. Controller 42 sets X_{MIN} , X_{MAX} , Y_{MIN} , and Y_{MAX} to search within the area defined by search box 276. Controller 42 further sets the luminance and x and y direction histograms to be on, with the linear combination unit for luminance set to detect low histogram levels relative to the rest of the image, e.g., the lowest 15% of the luminance levels (368). As a confirmation of the detection of the nostrils or other facial feature being detected, search box 276, which is established around an eye 274 of the driver using an anthropomorphic model, may be analyzed for characteristics indicative of an eye present in the search box. These characteristics may include, for example, a moving eyelid, a pupil, iris or cornea, a shape corresponding to an eye, a shadow corresponding to an eye, or any other indica indicative of an eye. Controller 42 sets the histogram formation units to detect the desired criteria. For example, Fig. 36 shows a sample histogram of a pupil 432, in which the linear combination units and validation units are set to detect pixels with very low luminance levels and high gloss that are characteristic of a pupil. The pupil may be verified by comparing the shapes of the x and y histograms to known characteristics of the pupil, which are generally symmetrical, keeping in mind

that the symmetry may be affected by the angular relationship between the sensor and the head of the driver.

Upon detection of the desired secondary facial criteria, identification of the nostrils is confirmed and detection of eye openings and closings is initiated. Alternatively, the criteria being detected to confirm identification of the nostrils may be eye blinking using the technique described below. If no blinking is detected in the search box, the search mode is reinitiated.

Blinking of the eye is detected during a tracking mode 400. In the tracking mode controller 42 sets XMIN, XMAX, YMIN, and YMAX to search within the area defined by search box 276. Controller 42 further sets the luminance and x and y direction histograms to be on, with the linear combination unit for luminance set to detect low histogram levels relative to the rest of the image, e.g., the lowest 15% of the luminance levels (368), in order to detect shadowing of the eye. During the tracking mode, the system monitors the location of nostrils 272 to detect movement of the head. Upon detected movement of the head, and a resultant shift in the position of X_N , Y_N , search box 276 is shifted according to the anthropomorphic model to retain the search box over the eye of the driver.

Fig. 33 shows the shapes of the x and y histograms 376, 378 with the eye open, and Fig. 34 shows the shapes of the x and y histograms 380, 382 with the eye closed. The shapes of the shadows, and especially the shape of the shadow with the eye closed will vary depending upon the location of the camera and the location of the light source creating the shadow, e.g., the sun or the IR light source. In any case, the width $MAX_x - MIN_x$ and the height $MAX_y - MIN_y$ of each histogram will generally be significantly greater for an open eye than for a closed eye. Controller 42 analyzes the width and height of each histogram to determine when the eye is open and when it is closed (382). An open eye may be determined by any number of characteristics of the x and y histograms, including width $MAX_x - MIN_x$ and height $MAX_y - MIN_y$, exceeding thresholds, NBPTS of each histogram exceeding a threshold, RMAX of each histogram exceeding a threshold, change in position of POSRMAX as compared to a closed eye, etc. Similarly, a closed eye may be determined by any number of characteristics of the x

and y histograms, including width $MAX_x - MIN_x$ and height $MAX_y - MIN_y$, being below thresholds, NBPTS of each histogram being below a threshold, RMAX of each histogram being below a threshold, change in position of POSRMAX as compared to an open eye, etc., In a preferred embodiment, controller 42 calculates the width $MAX_x - MIN_x$ and height $MAX_y - MIN_y$ of each histogram and utilizes thresholds to determine whether the eye is open or closed. If each width $MAX_x - MIN_x$ and height $MAX_y - MIN_y$ exceed thresholds, the eye is determined to be open. If each of width $MAX_x - MIN_x$ and height $MAX_y - MIN_y$ fall below thresholds (which may be different from the thresholds used to determine an open eye), the eye is determined to be closed (384). MAX and MIN are preferably the MAX and MIN calculated in the histogram formation units. On the other hand, MAX and MIN may be other thresholds, e.g., the points on the histograms corresponding to $RMAX/2$ or some other threshold relative to RMAX.

Controller 42 analyzes the number of frames the eye is open and closed over time to determine the duration of each blink and/or the interval between blinks (386). Using this information, controller 42 determines whether the driver is drowsy (388). Upon determining that the driver is drowsy, controller 42 generates an alarm to awaken the driver (390) or another signal indicative that the driver is sleeping.

Controller 42 constantly adapts operation of the system, especially in varying lighting levels. Controller 42 may detect varying lighting conditions by periodically monitoring the luminance histogram and adapting the gain bias of the sensor to maintain as broad a luminance spectrum as possible. Controller 42 may also adjust the thresholds that are used to determine shadowing, etc. to better distinguish eye and nostril shadowing from noise, e.g. shadowing on the side of the nose, and may also adjust the sensor gain to minimize this effect. If desired controller 42 may cause the histogram formation units to form a histogram of the iris. This histogram may also be monitored for consistency, and the various thresholds used in the system adjusted as necessary.

It will be appreciated that while the invention has been described with respect to detection of the eyes of a driver using certain criteria, the invention is capable of detecting any criteria of the eyes using any possible measurable characteristics of the pixels, and that the characteristics of a driver falling asleep may be discerned from any other information in the histograms formed by the invention. Also, while the invention

has been described with respect to detecting driver drowsiness, it is applicable to any application in which drowsiness is to be detected. More generally, although the present invention has been described with respect to certain embodiments and examples, variations exist that are within the scope of the invention as described in the following
5 claims.

CLAIMS

1. A process of detecting a person falling asleep, the process comprising the steps of:

- 5 acquiring an image of the face of the person;
 selecting pixels of the image having characteristics corresponding to
characteristics of at least one eye of the person;
 forming at least one histogram of the selected pixels;
 analyzing the at least one histogram over time to identify each opening
10 and closing of the eye; and
 determining from the opening and closing information on the eye,
characteristics indicative of a person falling asleep.

2. The process according to claim 1 further comprising the step of identifying a
sub-area of the image comprising the at least one eye prior to the step of selecting pixels
15 of the image having characteristics corresponding to characteristics of at least one eye,
and wherein the step of selecting pixels of the image having characteristics corresponding
to characteristics of at least one eye comprises selecting pixels within the sub-area of the
image.

3. The process according to claim 2 wherein the step of identifying a sub- area
20 of the image comprising the at least one eye comprises the steps of:
 identifying the head of the person in the image; and
 identifying the sub-area of the image using an anthropomorphic model.

4. The process according to claim 3 wherein the step of identifying head of the
person in the image comprises the steps of:
25 selecting pixels of the image having characteristics corresponding to
edges of the head of the person;
 forming histograms of the selected pixels projected onto orthogonal axes;
and
 analyzing the histograms of the selected pixels to identify the edges of the
30 head of the person.

5. The process according to claim 2 wherein the step of identifying a sub- area of the image comprising the at least one eye comprises the steps of:

identifying the location of a facial characteristic of the person in the image; and

5 identifying the sub-area of the image using an anthropomorphic model and the location of the facial characteristic.

6. The process according to claim 5 wherein the step of identifying the location of a facial characteristic of the person in the image comprises the steps of:

10 selecting pixels of the image having characteristics corresponding to the facial characteristic;

forming histograms of the selected pixels projected onto orthogonal axes; and

analyzing the histograms of the selected pixels to identify the position of the facial characteristic in the image.

15 7. The process according to claim 6 wherein the facial characteristic is the nostrils of the person, and wherein the step of selecting pixels of the image having characteristics corresponding to the facial characteristic comprises selecting pixels having low luminance levels.

20 8. The process according to claim 7 further comprising the step of analyzing the histograms of the nostril pixels to determine whether the spacing between the nostrils is within a desired range and whether the dimensions of the nostrils fall within a desired range.

9. The process according to claim 1 wherein:

25 the step of selecting pixels of the image having characteristics corresponding to characteristics of at least one eye of the person comprises selecting pixels having low luminance levels corresponding to shadowing of the eye; and

wherein the step analyzing the at least one histogram over time to identify each opening and closing of the eye comprises analyzing the shape of the eye shadowing to determine openings and closings of the eye.

10. The process according to claim 9 wherein the step of forming at least one histogram of the selected pixels comprises forming histograms of shadowed pixels of the eye projected onto orthogonal axes, and wherein the step of analyzing the shape of the eye shadowing comprises analyzing the width and height of the shadowing.

5 11. The process according to claim 1 wherein:

the step of selecting pixels of the image having characteristics corresponding to characteristics of at least one eye of the person comprises selecting pixels in movement corresponding to blinking; and

10 wherein the step analyzing the at least one histogram over time to identify each opening and closing of the eye comprises analyzing the number of pixels in movement over time to determine openings and closings of the eye.

12. The process according to claim 11 wherein the step of selecting pixels of the image having characteristics corresponding to characteristics of at least one eye of the person comprises selecting having characteristics selected from the group consisting of i) DP=1, ii) CO indicative of a blinking eyelid, iii) velocity indicative of a blinking eyelid, and iv) up and down movement indicative of a blinking eyelid.

13. The process according to claim 5 wherein the step of identifying a facial characteristic of the person in the image comprises the step of searching sub-images of the image to identify the facial characteristic.

20 14. The process according to claim 7 wherein the step of identifying a facial characteristic of the person in the image comprises the step of searching sub-images of the image to identify the nostrils.

15. The process according to claim 13 wherein the facial characteristic is a first facial characteristic and further comprising the steps of:

25 using an anthropomorphic model and the location of the first facial characteristic to select a sub-area of the image containing a second facial characteristic;

selecting pixels of the image having characteristics corresponding to the second facial characteristic; and

30 analyzing the histograms of the selected pixels of the second facial characteristic to confirm the identification of the first facial characteristic.

16. An apparatus for detecting a person falling asleep, the apparatus comprising:

a sensor for acquiring an image of the face of the person, the image comprising pixels corresponding to the eye of the person;

5 a controller; and

a histogram formation unit for forming a histogram on pixels having selected characteristics,

the controller controlling the histogram formation unit to select pixels of the image having characteristics corresponding to characteristics of at least one eye of the person and to form a histogram of the selected pixels, the controller analyzing the histogram over time to identify each opening and closing of the eye, and determining from the opening and closing information on the eye, characteristics indicative of a person falling asleep.

17. The apparatus according to claim 16 wherein the controller interacts with the histogram formation unit to identify a sub-area of the image comprising the at least one eye, and the controller controls the histogram formation unit to select pixels of the image having characteristics corresponding to characteristics of at least one eye only within the sub-area of the image.

18. The apparatus according to claim 17 wherein:

20 the controller interacts with the histogram formation unit to identify the head of the person in the image; and

the controller identifies the sub-area of the image using an anthropomorphic model.

19. The apparatus according to claim 18 wherein:

25 the histogram formation unit selects pixels of the image having characteristics corresponding to edges of the head of the person and forms histograms of the selected pixels projected onto orthogonal axes; and

the controller analyzes the histograms of the selected pixels to identify the edges of the head of the person.

30 20. The apparatus according to claim 17 wherein:

the controller interacts with the histogram formation unit to identify the location of a facial characteristic of the person in the image; and

the controller identifies the sub-area of the image using an anthropomorphic model and the location of the facial characteristic.

5 21. The apparatus according to claim 20 wherein:

the histogram formation unit selects pixels of the image having characteristics corresponding to the facial characteristic and forms histograms of the selected pixels projected onto orthogonal axes;

10 the controller analyzes the histograms of the selected pixels to identify the position of the facial characteristic in the image.

22. The apparatus according to claim 21 wherein the facial characteristic is the nostrils of the person, and wherein the histogram formation unit selects pixels of the image having low luminance levels corresponding to the luminance level of the nostrils.

15 23. The apparatus according to claim 22 wherein the controller analyzes the histograms of the nostril pixels to determine whether the spacing between the nostrils is within a desired range and whether the dimensions of the nostrils fall within a desired range.

24. The apparatus according to claim 16 wherein:

20 the histogram formation unit selects pixels of the image having low luminance levels corresponding to shadowing of the eye; and

wherein the controller analyzes the shape of the eye shadowing to determine openings and closings of the eye.

25 25. The apparatus according to claim 24 wherein histogram formation unit forms histograms of shadowed pixels of the eye projected onto orthogonal axes, and wherein the controller analyzes the width and height of the shadowing to determine openings and closings of the eye.

26. The apparatus according to claim 16 wherein:

the histogram formation unit selects pixels of the image in movement corresponding to blinking; and

the controller analyzes the number of pixels in movement over time to determine openings and closings of the eye.

27. The apparatus according to claim 26 wherein the histogram formation unit selects pixels of the image having characteristics of movement corresponding to blinking, such characteristics being selected from the group consisting of i) DP=1, ii) CO
5 such characteristics being selected from the group consisting of i) DP=1, ii) CO indicative of a blinking eyelid, iii) velocity indicative of a blinking eyelid, and iv) up and down movement indicative of a blinking eyelid.

28. The apparatus according to claim 20 wherein the controller interacts with the histogram formation unit to search sub-images of the image to identify the facial
10 characteristic.

29. The apparatus according to claim 22 wherein the controller interacts with the histogram formation unit to search sub-images of the image to identify the nostrils.

30. The apparatus according to claim 28 wherein the facial characteristic is a first facial characteristic and further comprising:

15 the controller using an anthropomorphic model and the location of the first facial characteristic to cause the histogram formation unit to select a sub-area of the image containing a second facial characteristic, the histogram formation unit selecting pixels of the image in the sub-area having characteristics corresponding to the second facial characteristic and forming a histogram of such pixels; and

20 the controller analyzing the histogram of the selected pixels corresponding to the second facial characteristic to confirm the identification of the first facial characteristic.

31. The apparatus according to claim 16 wherein the sensor is integrally constructed with the controller and the histogram formation unit.

25 32. The apparatus according to claim 16 further comprising an alarm, the controller operating the alarm upon detection of the person falling asleep.

33. The apparatus according to claim 16 further comprising an illumination source, the sensor being adapted to view the person when illuminated by the illumination source.

34. The apparatus according to claim 33 wherein the illumination source is a source of IR radiation.

35. A rear-view mirror assembly for a vehicle which comprises:

a rear-view mirror; and

5 the apparatus according to claim 16 mounted to the rear-view mirror.

36. The rear-view mirror assembly according to claim 35 further comprising a bracket attaching the apparatus to the rear-view mirror.

37. The rear-view mirror assembly according to claim 35 further comprising a housing having an open side and an interior, the rear-view mirror being mounted to the open side of the housing, the rear view mirror being see-through from the interior of the housing to an exterior of the housing, the apparatus being mounted interior to the housing with the sensor directed toward the rear-view mirror.

38. The rear-view mirror assembly according to claim 37 further comprising a joint attaching the apparatus to the rear-view mirror assembly, the joint adapted to maintain the apparatus in a position facing a driver of the vehicle during adjustment of the mirror assembly by the driver.

39. The rear-view mirror assembly according to claim 35 further comprising a source of illumination directed toward the person, the sensor being adapted to view the person when illuminated by the source of illumination.

20 40. The rear-view mirror assembly according to claim 35 further comprising an alarm, the controller operating the alarm upon detection of the person falling asleep.

41. A rear-view mirror assembly which comprises:

a rear-view mirror; and

25 the apparatus according to claim 16, the sensor being mounted to the rear-view mirror, the controller and the histogram formation unit being located remote from the sensor.

42. A vehicle comprising the apparatus according to claim 16.

43. A process of detecting a feature of an eye, the process comprising the steps of:

acquiring an image of the face of the person, the image comprising pixels corresponding to the feature to be detected;

selecting pixels of the image having characteristics corresponding to the feature to be detected;

5 forming at least one histogram of the selected pixels;

analyzing the at least one histogram over time to identify characteristics indicative of the feature to be detected.

44. The process according to claim 43 wherein the feature is the iris, pupil or cornea.

10 45. An apparatus for detecting a feature of an eye, the apparatus comprising:

a sensor for acquiring an image of the eye, the image comprising pixels corresponding to the feature to be detected;

a controller; and

15 a histogram formation unit for forming a histogram on pixels having selected characteristics,

the controller controlling the histogram formation unit to select pixels of the image having characteristics corresponding to characteristics of at least one eye of the person and to form a histogram of the selected pixels, the controller analyzing the histogram over time to identify each opening and closing of the eye, and determining
20 from the opening and closing information on the eye, characteristics indicative of a person falling asleep.

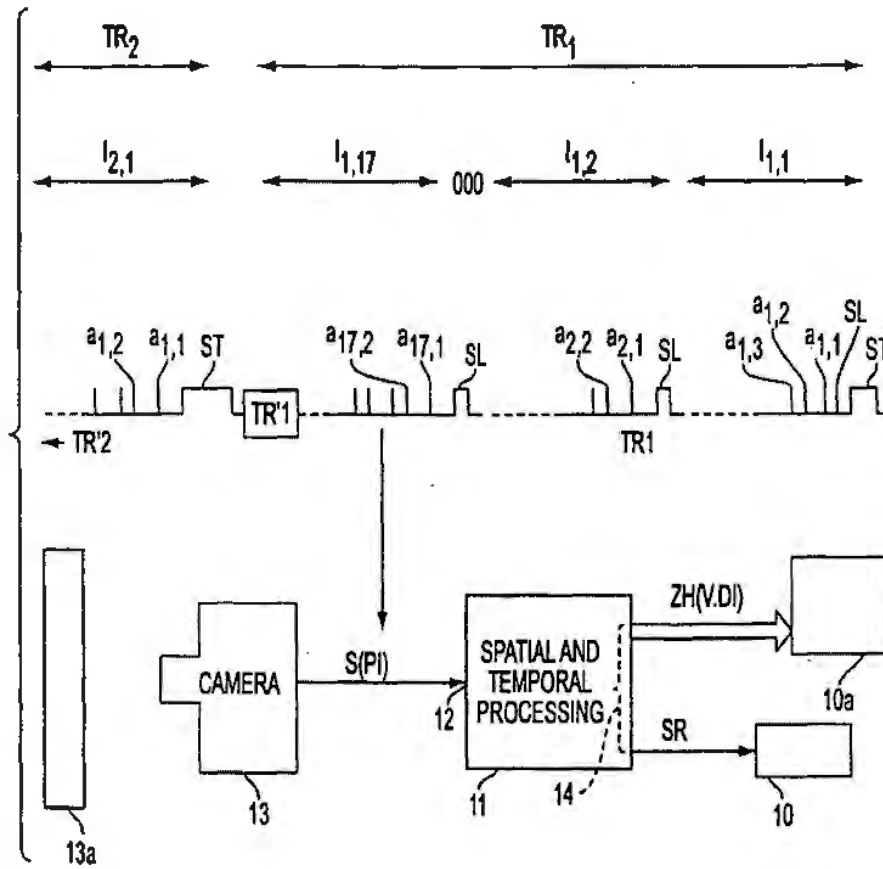

FIG. 1

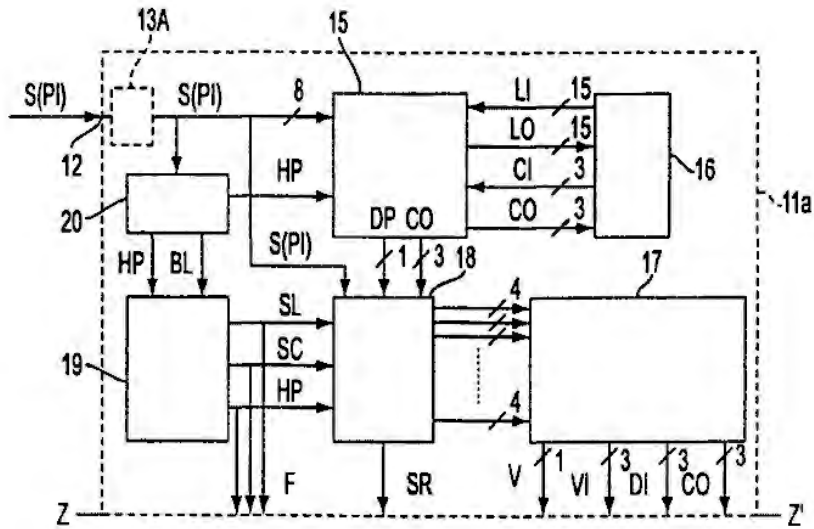

FIG. 2

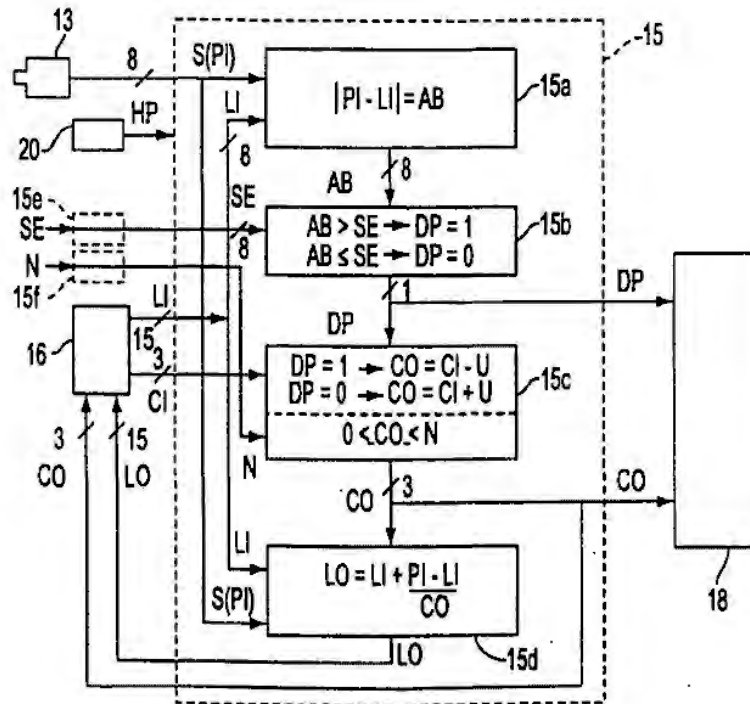

FIG. 3

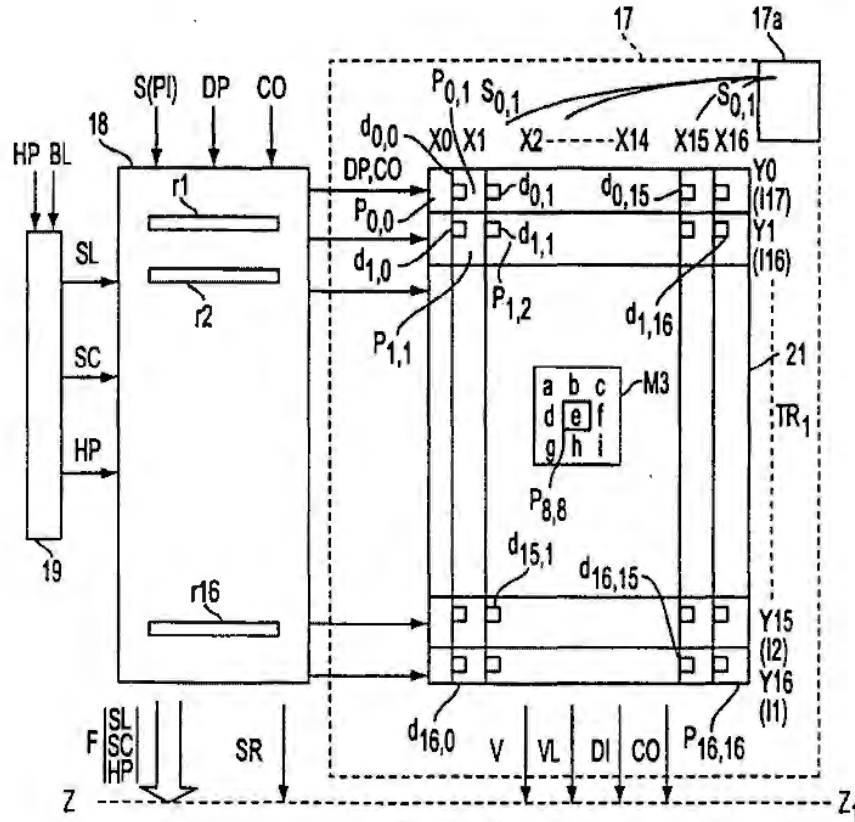

FIG. 4

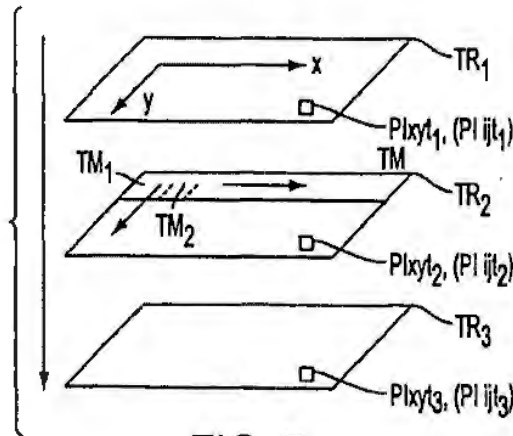

FIG. 5

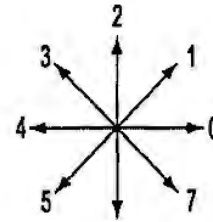

FIG. 6

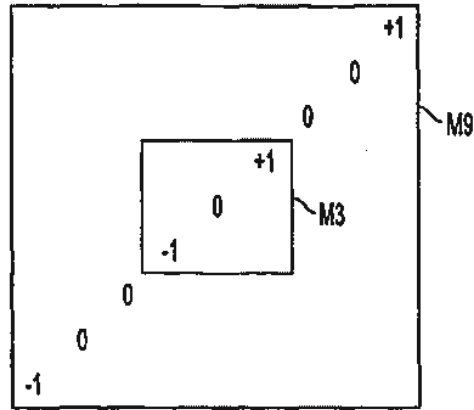

FIG. 7

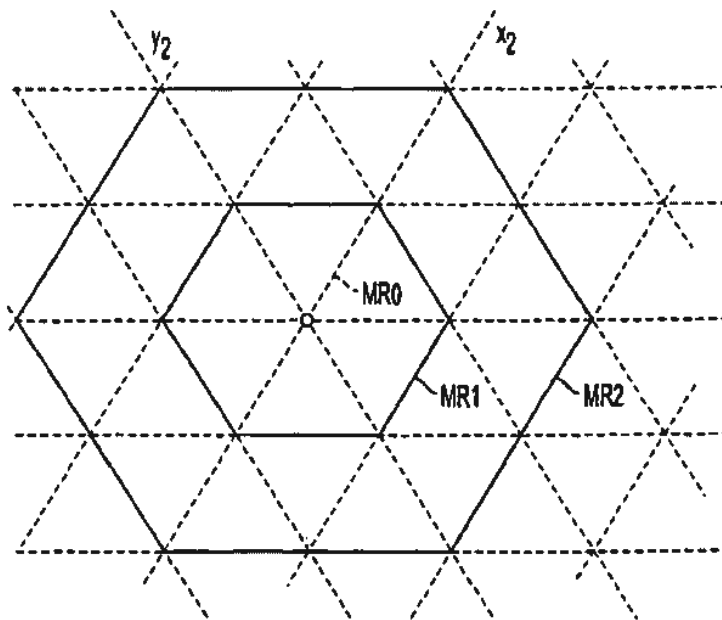

FIG. 8

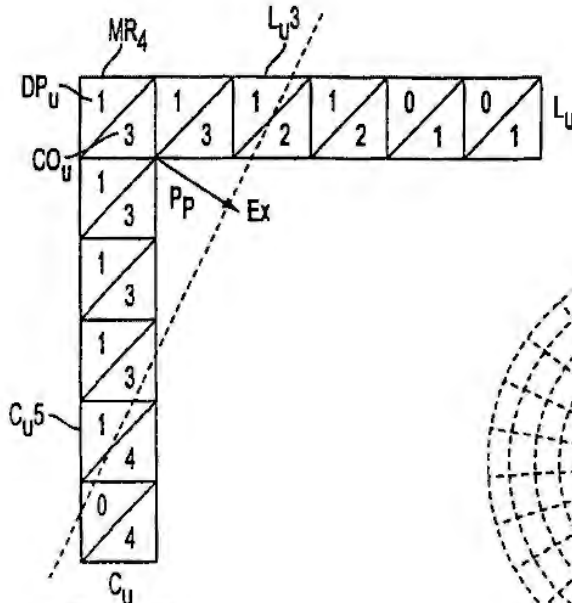

FIG. 9

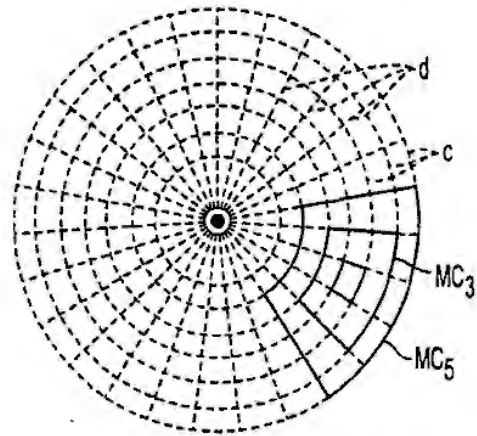
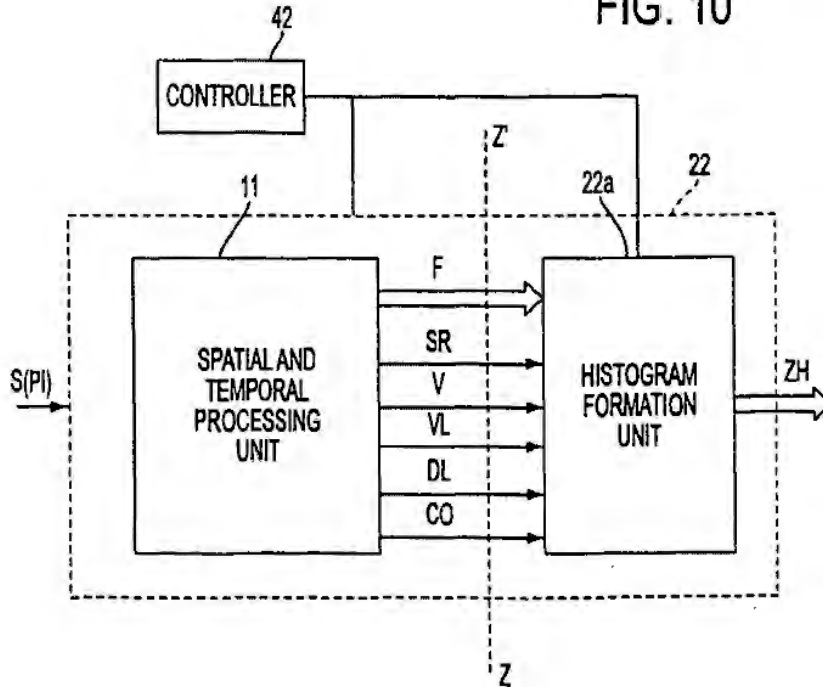

FIG. 10



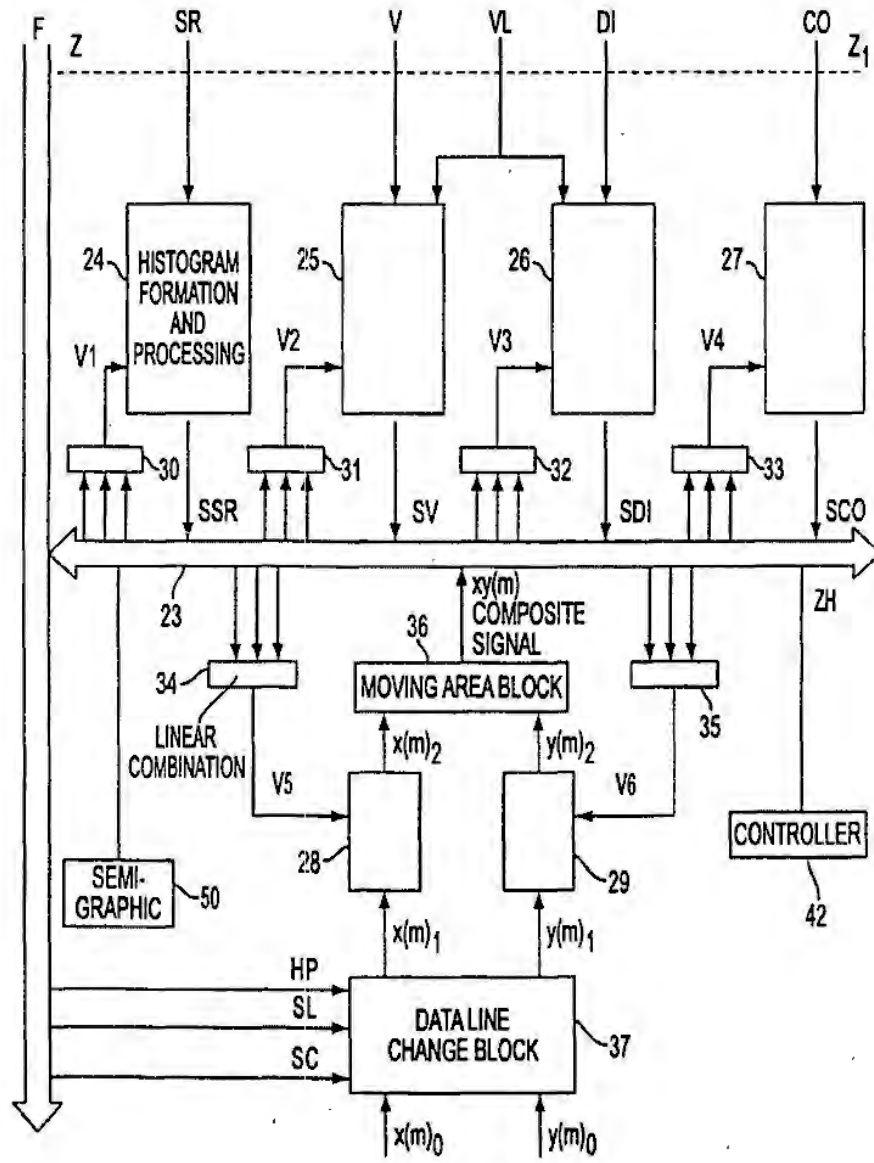

FIG. 12

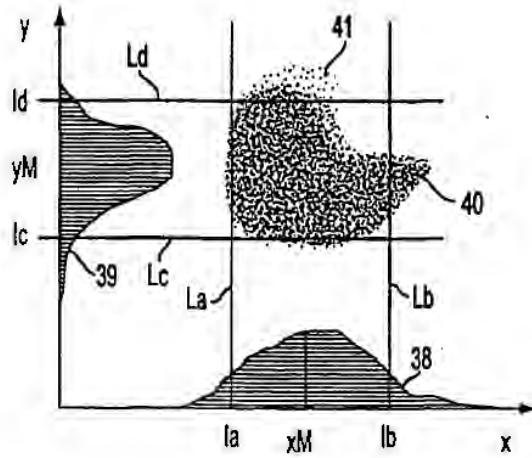

FIG. 13

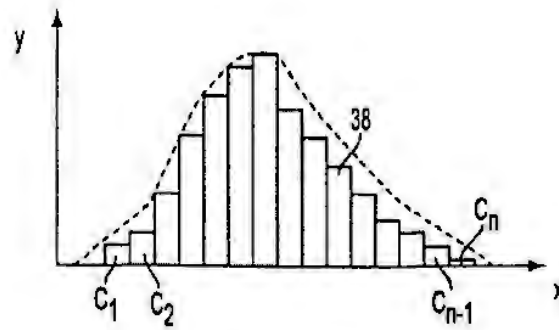

FIG. 16

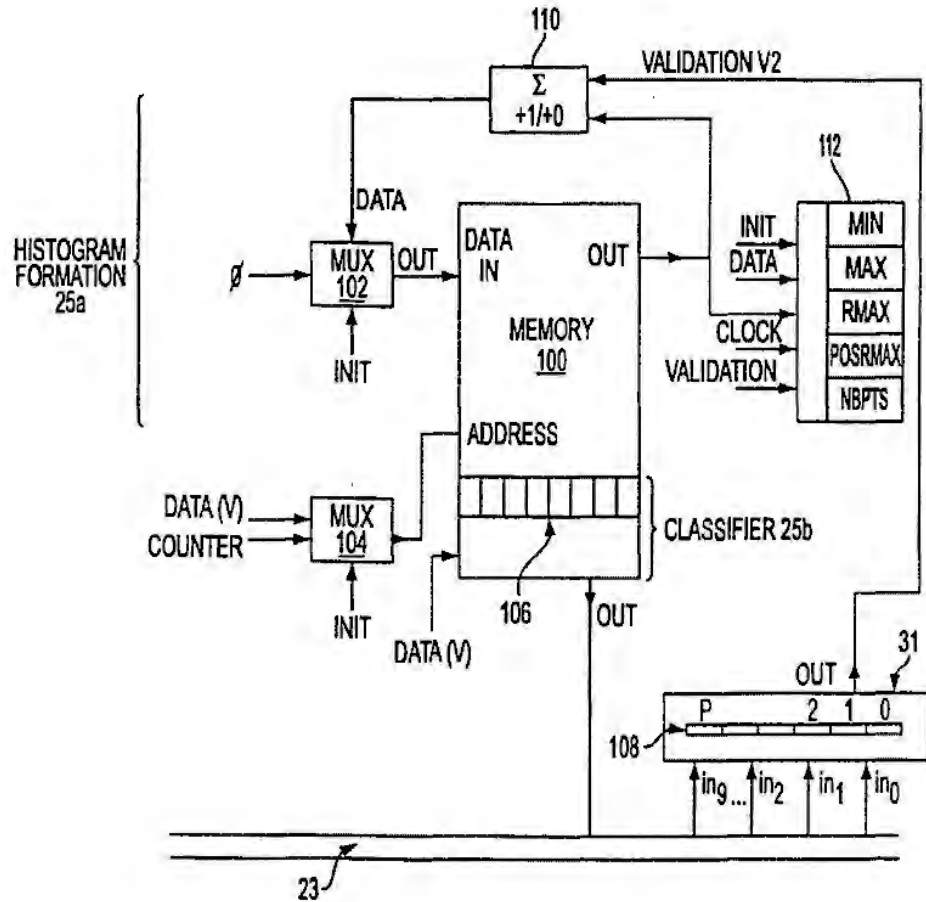

FIG. 14

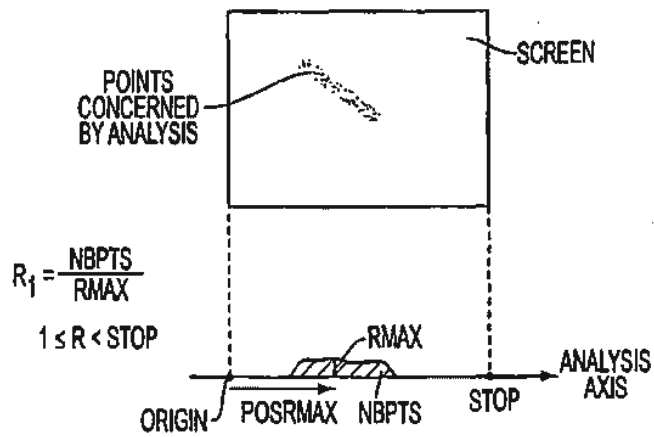

FIG. 15A

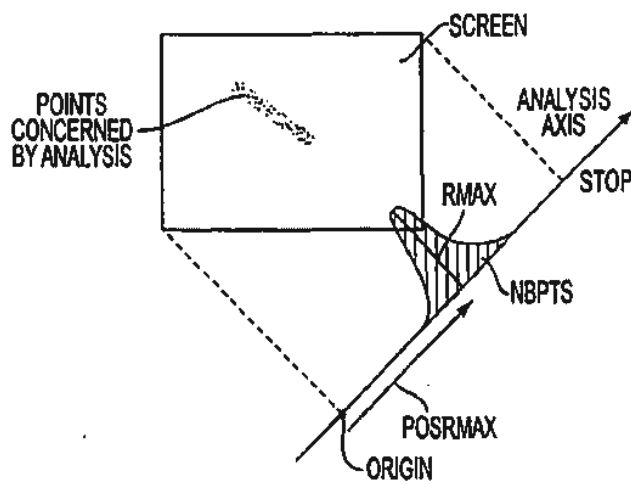

FIG. 15B

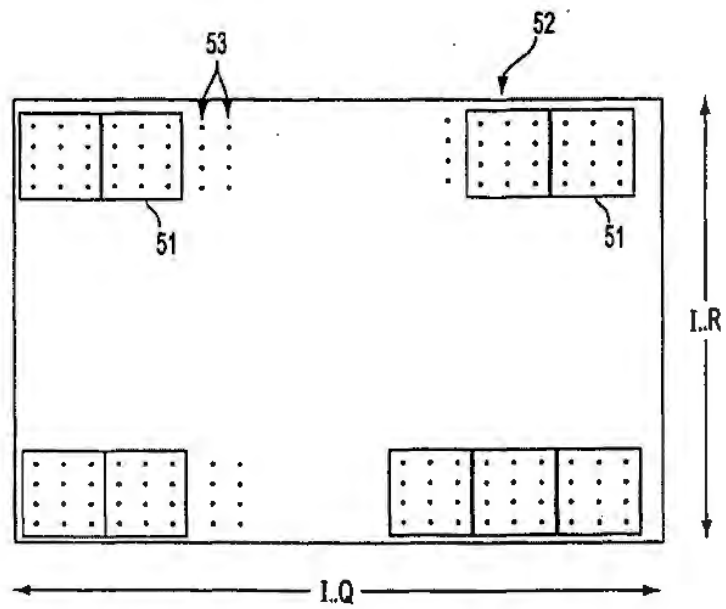
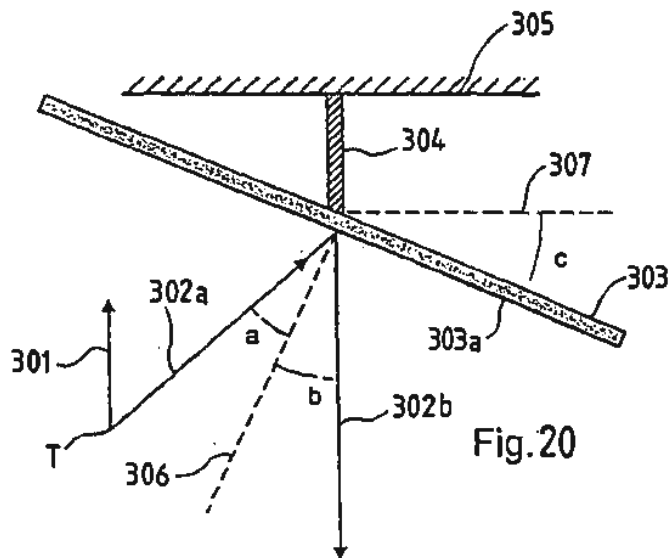
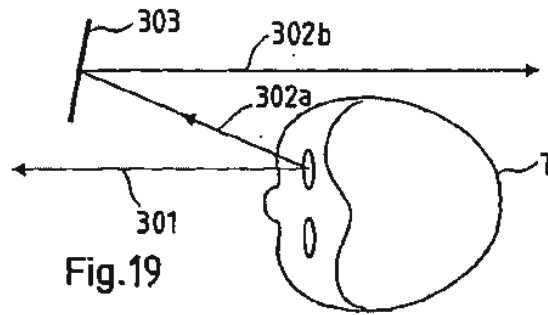
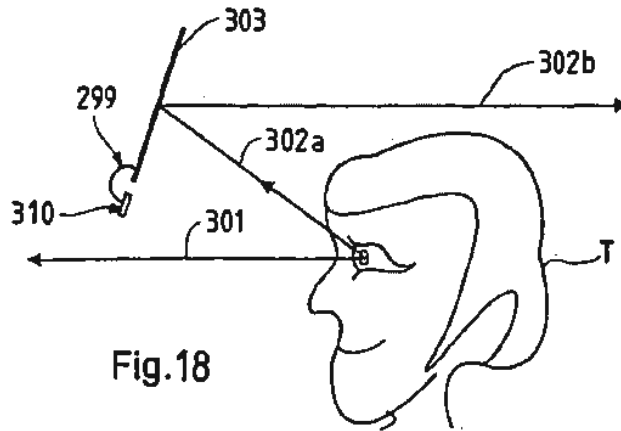

FIG. 17

11/20



SUBSTITUTE SHEET (RULE 26)

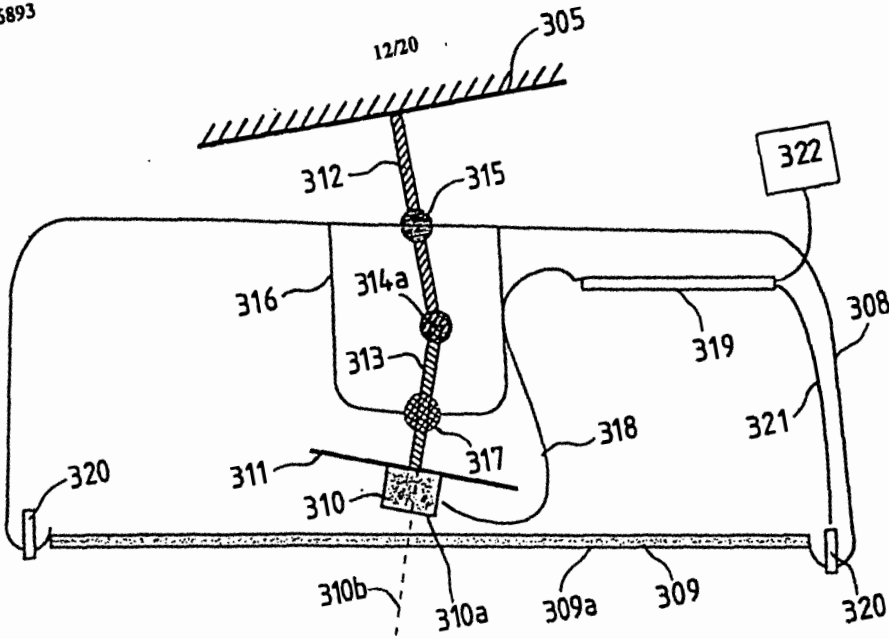

Fig. 21

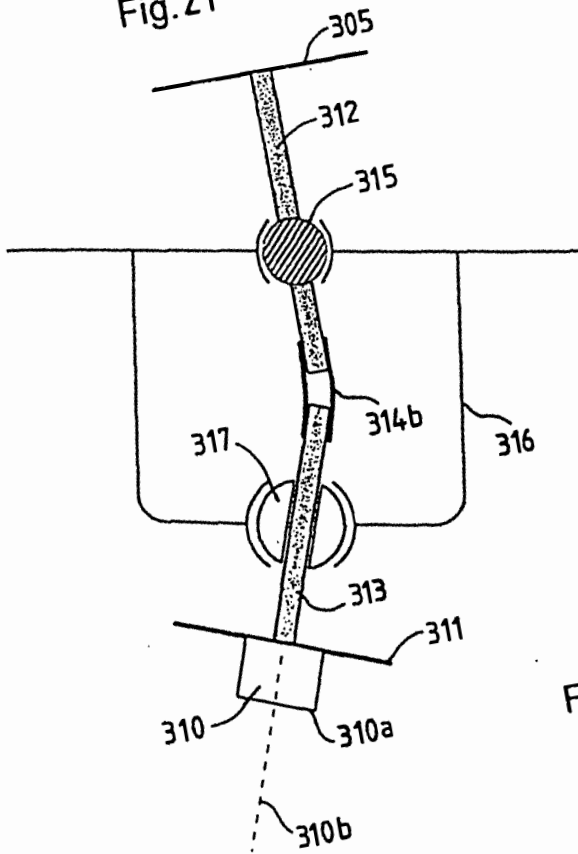
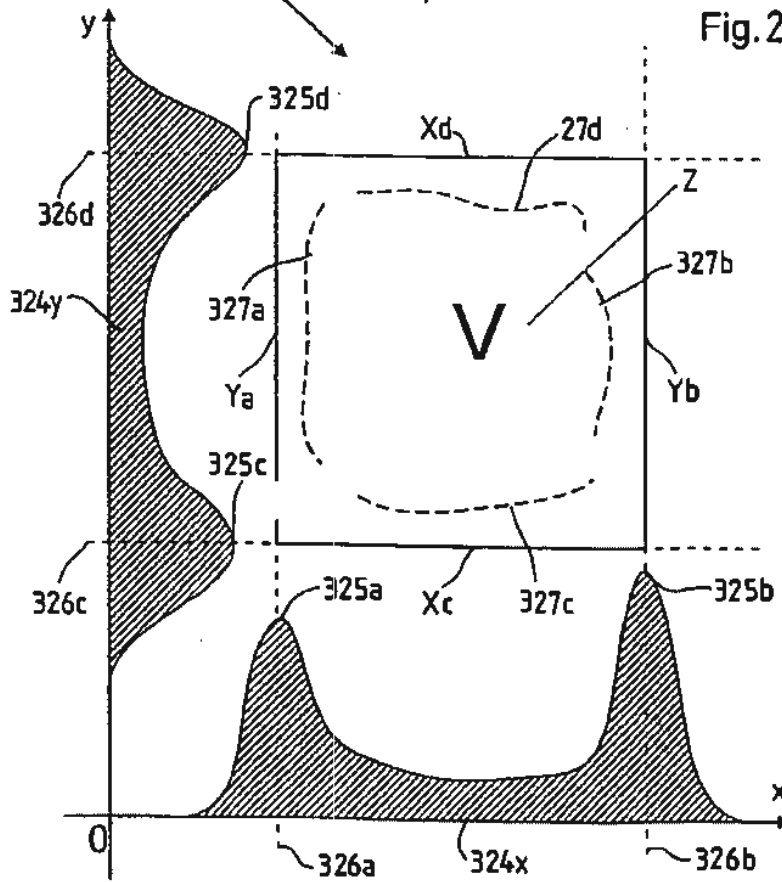
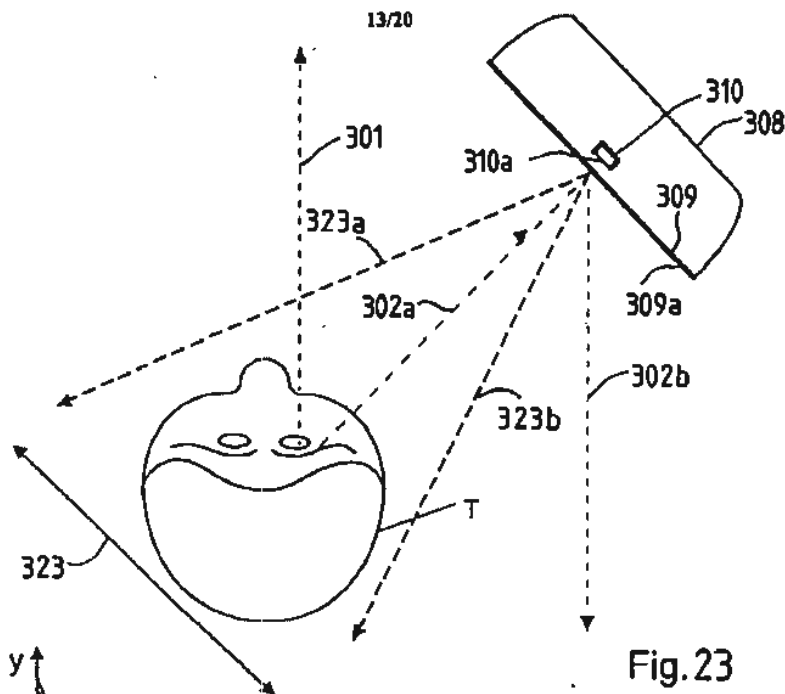

Fig. 22

SUBSTITUTE SHEET (RULE 26)



SUBSTITUTE SHEET (RULE 26)

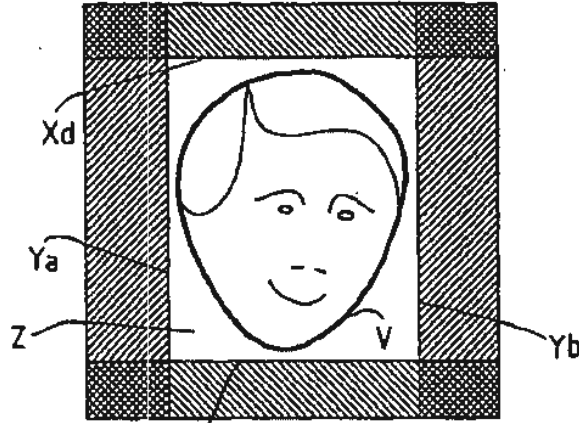

Fig. 25

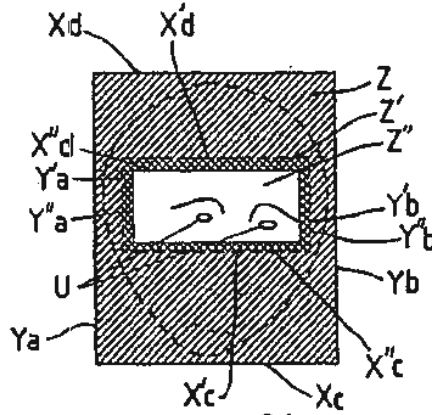

Fig. 26

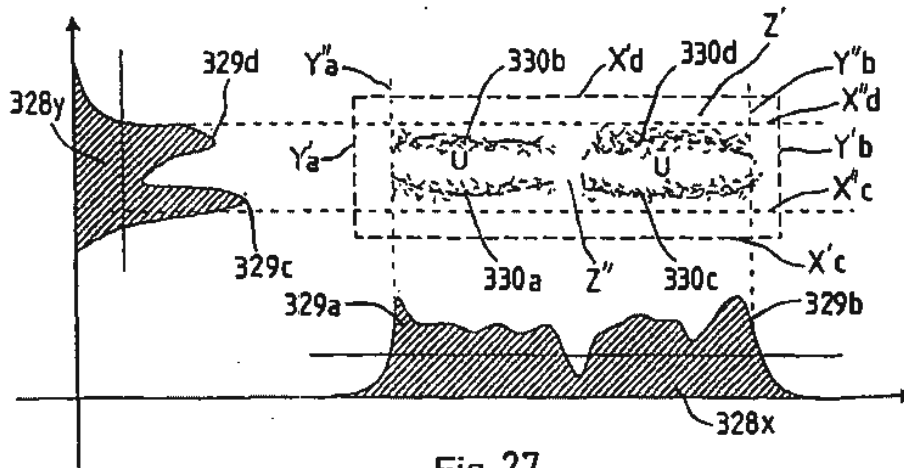

Fig. 27

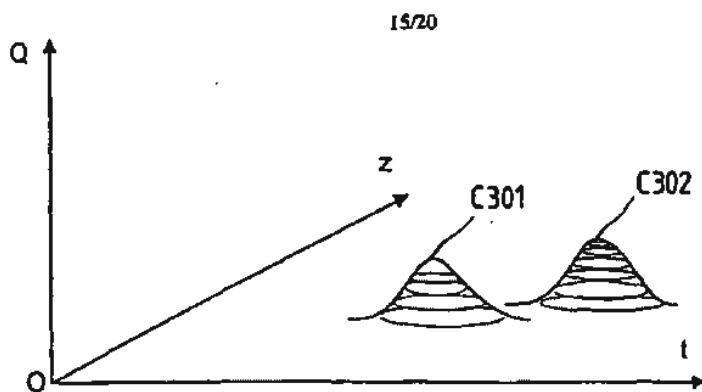

Fig. 28

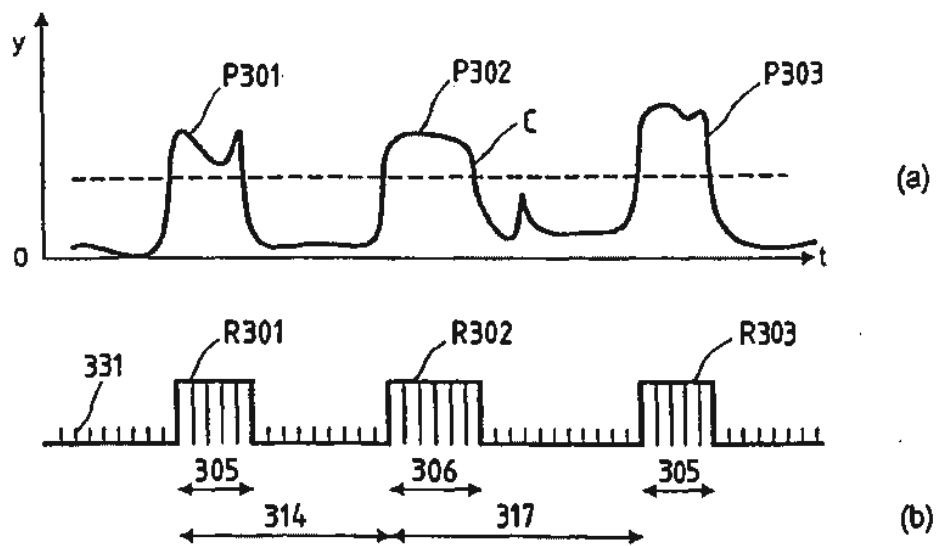

Fig. 29

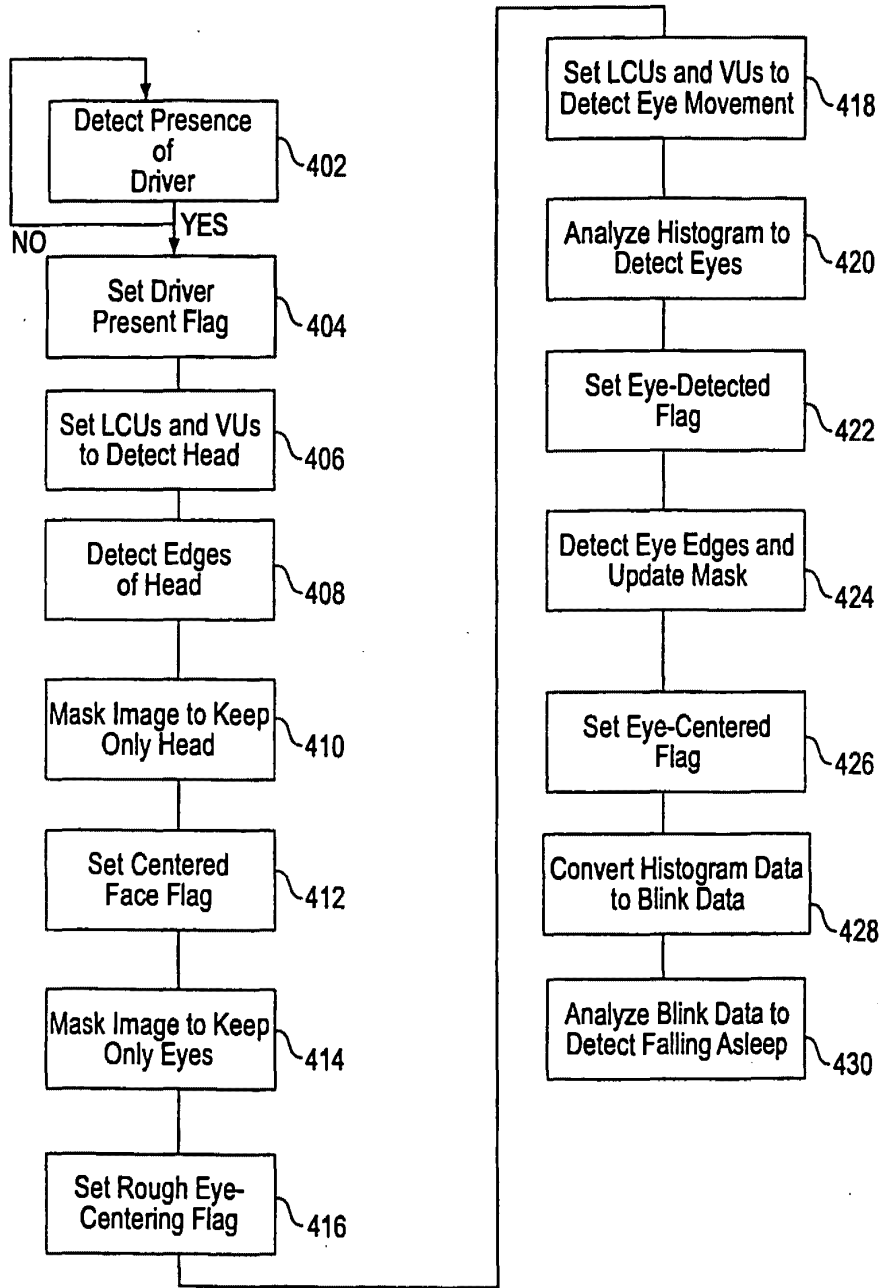

FIG. 30

17/20

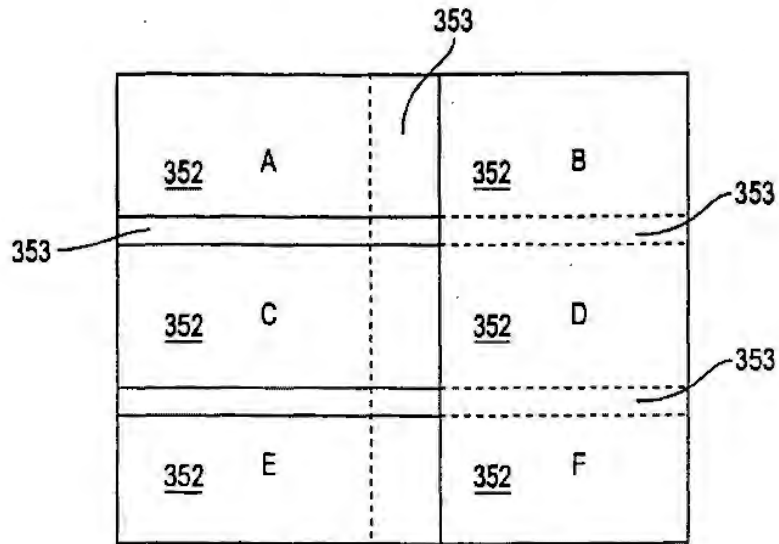

FIG. 31

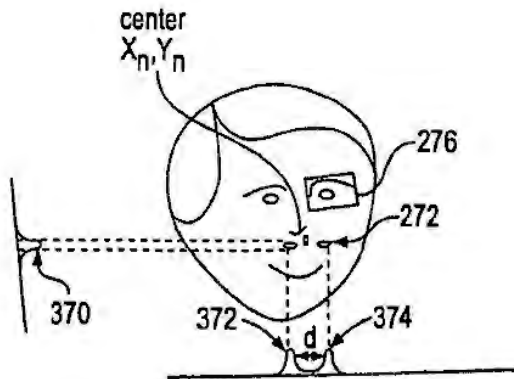

FIG. 32

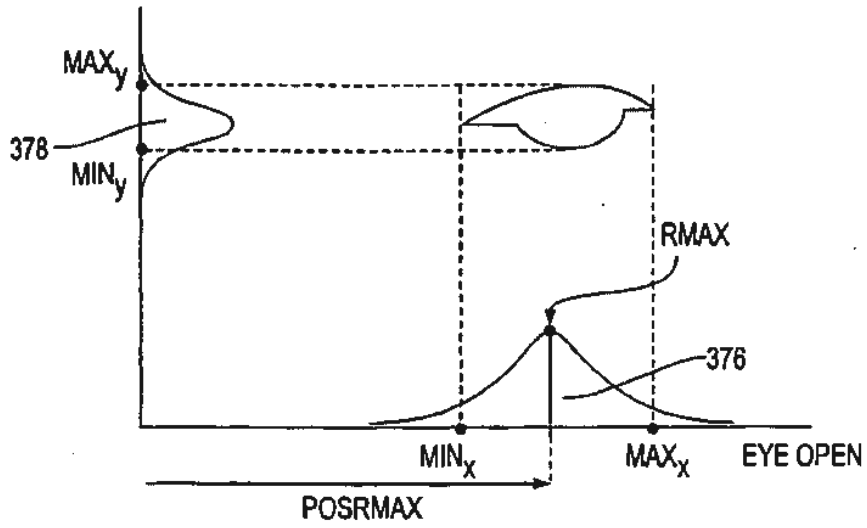

FIG. 33

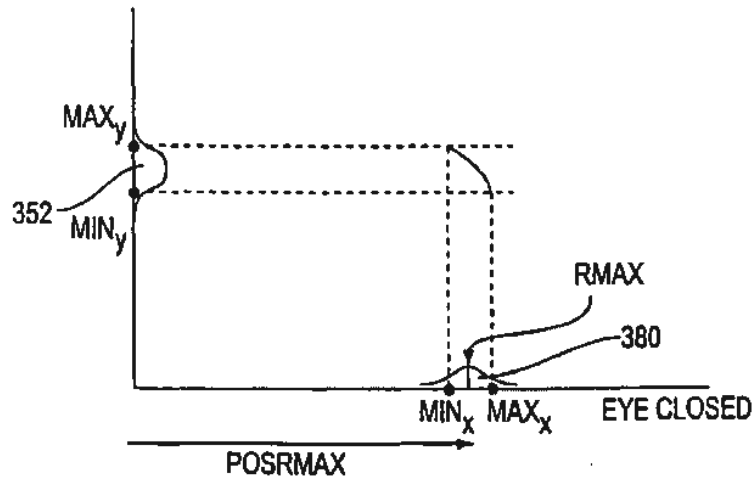

FIG. 34

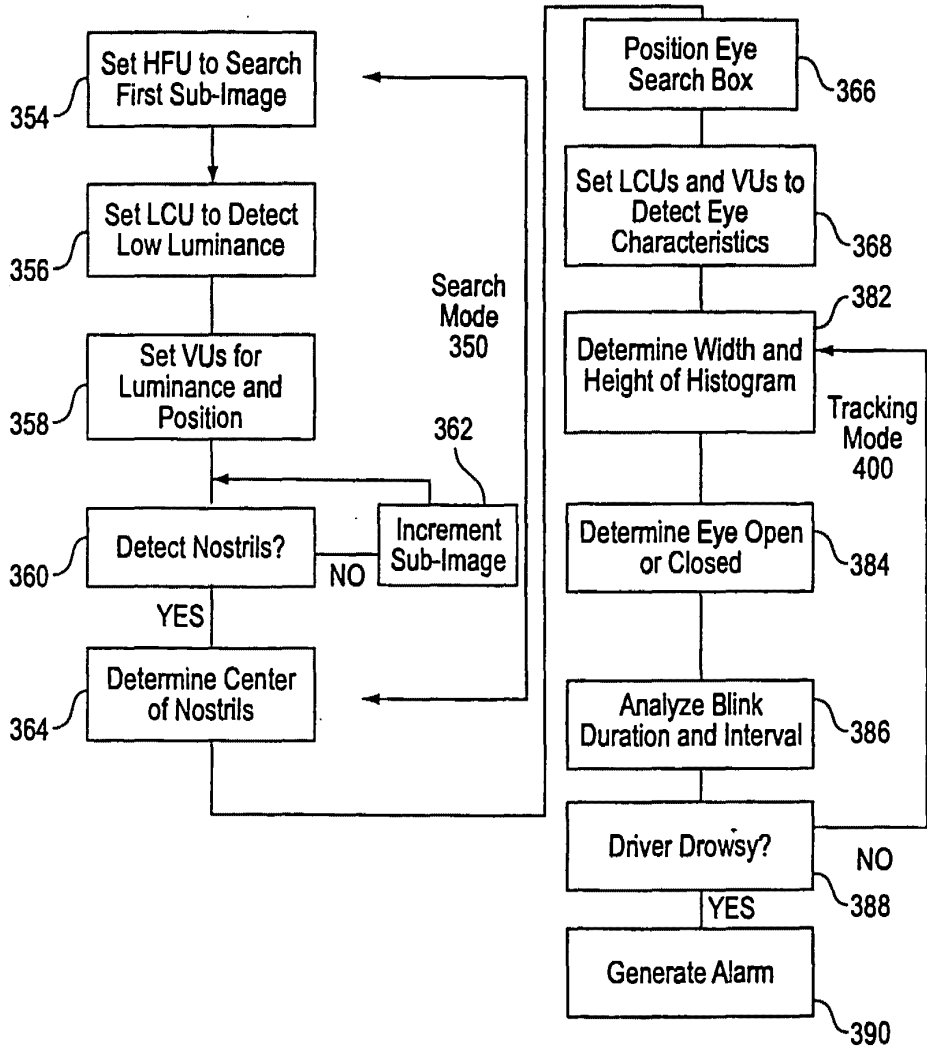

FIG. 35

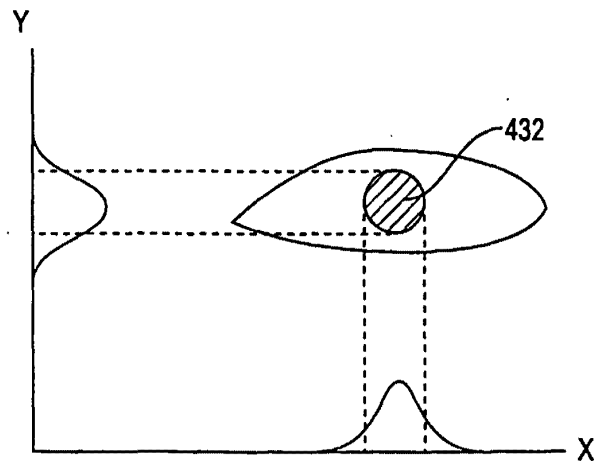

FIG. 36

INTERNATIONAL SEARCH REPORT

International Application No

PCT/EP 99/00300

A. CLASSIFICATION OF SUBJECT MATTER IPC 6 G08B21/00		
According to International Patent Classification (IPC) or to both national classification and IPC		
B. FIELDS SEARCHED		
Minimum documentation searched (classification system followed by classification symbols) IPC 6 G08B G06T		
Documentation searched other than minimum documentation to the extent that such documents are included in the fields searched		
Electronic data base consulted during the international search (name of data base and, where practical, search terms used)		
C. DOCUMENTS CONSIDERED TO BE RELEVANT		
Category	Citation of document, with indication, where appropriate, of the relevant passages	Relevant to claim No.
X,P	WO 98 05002 A (CARLUS MAGNUS LIMITED ;PRIM PATRICK (FR)) 5 February 1998 cited in the application see claims 1-14 ---	1-45
A	DE 197 15 519 A (MITSUBISHI MOTORS CORP) 6 November 1997 see the whole document ---	1-45
A	WO 97 01246 A (STEED VAN P ;CEJKA ROBERT K (US)) 9 January 1997 see abstract -----	1-45
<input type="checkbox"/> Further documents are listed in the continuation of box C.		
<input checked="" type="checkbox"/> Patent family members are listed in annex.		
* Special categories of cited documents :		
"A" document defining the general state of the art which is not considered to be of particular relevance "E" earlier document but published on or after the international filing date "L" document which may throw doubts on priority claim(s) or which is cited to establish the publication date of another citation or other special reason (as specified) "O" document referring to an oral disclosure, use, exhibition or other means "P" document published prior to the international filing date but later than the priority date claimed		
"T" later document published after the international filing date or priority date and not in conflict with the application but cited to understand the principle or theory underlying the invention "X" document of particular relevance; the claimed invention cannot be considered novel or cannot be considered to involve an inventive step when the document is taken alone "Y" document of particular relevance; the claimed invention cannot be considered to involve an inventive step when the document is combined with one or more other such documents, such combination being obvious to a person skilled in the art. "&" document member of the same patent family		
Date of the actual completion of the international search	Date of mailing of the international search report	
28 May 1999	04/06/1999	
Name and mailing address of the ISA European Patent Office, P.B. 5818 Patentlaan 2 NL - 2280 HW Rijswijk Tel. (+31-70) 340-2040, Tx. 31 651 epo nl, Fax: (+31-70) 340-3016		Authorized officer Sgura, S

INTERNATIONAL SEARCH REPORT

Information on patent family members

International application No
PCT/EP 99/00300

Patent document cited in search report	Publication date	Patent family member(s)	Publication date
WO 9805002 A	05-02-1998	FR 2751772 A	30-01-1998
		AU 3775397 A	20-02-1998
		EP 0912964 A	06-05-1999
DE 19715519 A	06-11-1997	JP 9277849 A	28-10-1997
		FR 2747346 A	17-10-1997
		US 5786765 A	28-07-1998
WO 9701246 A	09-01-1997	AU 6480896 A	22-01-1997

Form PCT/ISA-W/210 (patent family annex) (July 1997)

This Page Is Inserted by IFW Operations
and is not a part of the Official Record

BEST AVAILABLE IMAGES

Defective images within this document are accurate representations of the original documents submitted by the applicant.

Defects in the images may include (but are not limited to):

- BLACK BORDERS
- TEXT CUT OFF AT TOP, BOTTOM OR SIDES
- FADED TEXT
- ILLEGIBLE TEXT
- SKEWED/SLANTED IMAGES
- COLORED PHOTOS
- BLACK OR VERY BLACK AND WHITE DARK PHOTOS
- GRAY SCALE DOCUMENTS

IMAGES ARE BEST AVAILABLE COPY.

**As rescanning documents *will not* correct images,
please do not report the images to the
Image Problems Mailbox.**

This Page Blank (us

This Page Blank (uspto)



Europäisches Patentamt
 European Patent Office
 Office européen des brevets

D 1

Publication number:

**0 380 659
 A1**

12

**EUROPEAN PATENT APPLICATION
 published in accordance with Art.
 158(3) EPC**

21 Application number: 87906460.8

51 Int. Cl.⁵: G06F 15/70

22 Date of filing: 02.10.87

66 International application number:
 PCT/JP87/00735

87 International publication number:
 WO 89/03094 (06.04.89 89/08)

43 Date of publication of application:
 08.08.90 Bulletin 90/32

71 Applicant: KABUSHIKI KAISHA KOMATSU
 SEISAKUSHO
 3-6, Akasaka 2-chome
 Minato-ku Tokyo 107(JP)

94 Designated Contracting States:
 DE FR GB SE

72 Inventor: NAGAO, Makoto
 9-11, Asahigaoka-cho Hirakata-shi
 Osaka 573(JP)
 Inventor: TERADA, Keiji
 18, Manda
 Hiratsuka-shi Kanagawa-ken 254(JP)

74 Representative: Setling, Günther, Dipl.-Ing. et
 al
 Patentanwälte von Kreisler, Setling, Werner
 Delchmannhaus am Hauptbahnhof
 D-5000 Köln 1(DE)

94 **METHOD OF RECOGNIZING LINEAR PATTERN.**

57 A method of recognizing linear pattern contained
 in the video data stored in an original video memory.
 A memory region of the original video memory is
 divided into a plurality of regions, projective
 waveforms at a plurality of different projection angles
 are found out for each of the regions from the video
 data of the divisions, the projection waveforms are
 analyzed to determine the presence or absence of
 any linear pattern, direction (θ) of line, line width (W)
 and line length (L) in each of the divisions, and a line
 segment corresponding to the linear pattern is pic-
 ked up for each of the divisions based upon the
 results of determination.

EP 0 380 659 A1

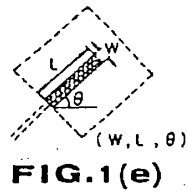
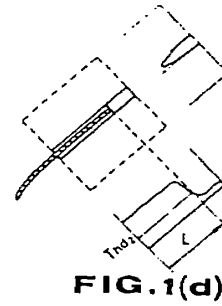
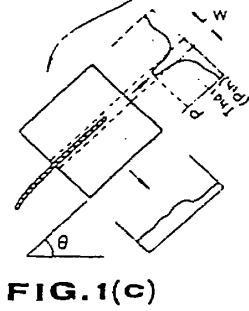
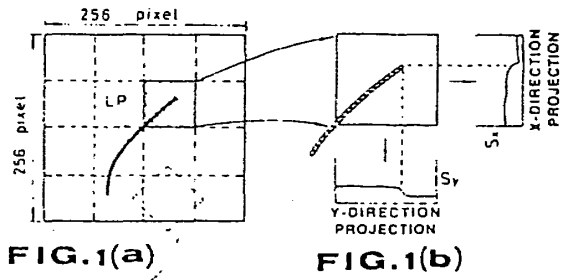

D E S C R I P T I O N

LINEAR PATTERN RECOGNIZING METHOD

TECHNICAL FIELD

This invention relates to a linear pattern recognizing method of automatically recognizing and extracting a linear pattern included in the image data which are stored in an original image memory.

BACKGROUND ART

A variety of methods have been proposed in the art to automatically detect cracks, uneven parts, etc. of a road surface or tunnel wall, which are heretofore detected visually. For instance Japanese Patent Application No's 229563/1983 and 233923/1984 have disclosed the following method: As shown in FIGS. 15 and 16, a laser scanning system comprising a laser oscillator 2, a mirror 3 and an electric motor 4, and a light receiving sensor 5, a distance recorder (not shown) are mounted on a vehicle 1. The road is scanned with the laser beam in a road crossing direction, and light scattered from the road is received by the light receiving sensor 5. When, in this case, there are no cracks or the like in the road surface to which the laser beam is applied, as shown in the part (a) of FIG. 17 a predetermined quantity of scattered light is received by the light receiving sensor 5. When, on the other hand, there are cracks or the like in the road surface, as shown in the part (b)

of FIG. 7, the quantity of light received by the light receiving sensor 5 is greatly reduced because of a shadow effect. In addition, in the method proposed, the output of the light receiving sensor 5 together with the output of the distance recorder is recorded by a video tape recorder (VTR) or the like, and then stored in a special purpose image memory. The data stored in the image memory are as shown in FIG. 18: that is, the X-direction address represents a vehicle traveling direction, the Y-direction address, a road crossing direction, and the Z-direction address, data (multi-gradation or binary data) on cracks. That is, the magnitude, position and configuration of an uneven part such as a crack can be detected by analyzing the data thus stored.

On the other hand, the method of automatically recognizing cracks using such as a road surface image has demanded for provision of a technique of detecting a linear pattern such as a crack with high accuracy because of the following reasons:

(I) There are a lot of noises because a road includes aggregate etc.

(II) Cracks are locally changed in direction and in width.

(III) There are a number of uncontinuous parts, cracks occurring intermittently.

(IV) The road surface condition depending greatly on the environmental conditions, construction method, etc. of the road, a variety of noises are superposed on one another. And formed crack patterns are not uniform; there may be formed lateral cracks, or honeycomb cracks.

Examples of a conventional linear pattern recognizing method are as follows:

(1) An image different in density is converted into binary data, to extract the region of dark (or light) lines, and thereafter a line thinning operation is carried out, to recognize the line.

(2) It is determined through correlation with a line detecting operator that there is a line in the high correlation region.

(3) The densities of picture elements in a plurality of directions of a point is summed up to obtain a line existing direction with respect to the point. This operation is repeatedly carried out in a follow-up mode, to recognize the line.

In addition, in the field of a character recognizing technique, the following methods are available:

(4) The black signal of a binary image is counted both in the X-direction and in the Y-direction, and a projection waveform is formed with the count values as waveform values, and collation is made with the reference pattern, to recognize the character.

(5) The region where lines are concentrated as in a character region is extracted from the result of projection of a wide region, and after each character is taken out of it, the projection waveform is collated with the reference pattern, to recognize the character.

The above-described conventional techniques (1), (2) and (3) are still disadvantageous in the following points: In general, they are weak against noise, and they are low in recognition accuracy although performing intricate operations. Hence, they are not applicable to the field of detecting cracks etc. of a road surface where a lot of noise components are generated, and

the lines formed therein are intricate in configuration.

In general, an operation of projection has an effect that density is averaged in the direction of projection. Therefore, in the above-described conventional techniques (4) and (5) in which a wide region is projected, it is difficult to recognize a thin linear pattern, and even if the projection is made in the line existing direction, it is impossible to recognize an intricate line such as a crack. Those techniques suffer further from the difficulty that it is necessary to provide the reference pattern for recognition.

Accordingly, an object of this invention is to eliminate the above-described difficulties. More specifically, an object of the invention is to provide a linear pattern recognizing method which can detect an intricate linear pattern such as cracks in a road surface with high accuracy.

Another object of the invention is to provide a linear pattern recognizing method which can detect especially a branch of an intricate linear pattern such as cracks in a road surface.

A further object of the invention is to provide a linear pattern recognizing method which can accurately perform a line detecting operation even in the case of a directional image which is formed for instance by a flying spot method.

DISCLOSURE OF THE INVENTION

In the invention, the memory region of an original image memory in which original image data have been stored is divided into a plurality of smaller regions, and the image data of the smaller regions are utilized to obtain projection waveforms at a plurality of projection angles for each smaller region. The

projection waveforms thus obtained are analyzed to detect the presence or absence, line direction, line width and line length of a linear pattern in each smaller region. According to the results of detection, a linear segment corresponding to the linear pattern is extracted for each smaller region.

The projection waveforms at the plurality of projection angles are obtained for each smaller region as follows: A dividing slit is provided for dividing the memory region of the original image memory into a plurality of smaller region, and the dividing slit is rotated with the image fixed, or the image is rotated with the dividing slit fixed. With respect to the rotated slit region thus obtained, projection waveforms in the x-direction and in the y-direction for instance are obtained. Those projection waveforms are analyzed to determine the line direction, line width and line length of a linear pattern for defining the configuration and direction of a linear segment.

Hence, according to the invention, a linear pattern can be recognized with high accuracy which is included in an image which has intricate lines such as cracks and has a lot of noise components. In addition, even a linear patter which is changed locally in width and in direction can be readily recognized as a linear segment by analysis of the projection waveforms without complicated operations. Furthermore, it is unnecessary to use a standard pattern such as a line detecting matching pattern, as a result of which a linear pattern to be recognized is not limited in width, length and direction. If the smaller regions are defined in such a manner that each of them overlaps the smaller

regions adjacent thereto, then the difficulty can be eliminated that a linear pattern is not completely detected because of the rotation of the slit.

Furthermore, in the invention, in analyzing of the projection waveforms, the projection waveforms obtained at the projection angles are normalized with predetermined functions having at least the projection angles as variables, and the projection waveforms thus normalized are utilized to determine the line direction, line width and line length of the linear pattern in each smaller region. As a result, the directional effect of the measured image is corrected. That is, in the case where the image data are directional, or directional background noise components are included, or the image (density and contrast) of a linear object differs depending on directions, the line direction and line width can be detected with high accuracy, and the difficulty is eliminated that the background noise components are recognized as linear objects. Thus, the line detecting operation is carried out with high stability.

Furthermore, in the invention, after extraction of the linear segments, the positional relationships of the smaller regions including a linear pattern are determined, and the results of determination are utilized to select interpolation regions for reprojection, and for each of the interpolation regions thus selected an operation of extracting the linear segment is carried out, so that the difficulty is positively eliminated that the line in the region boundary is not completely detected because of rotation of the image or the slit. In other words, first the image data is divided coarsely, and the projection waveforms are

analyzed; and thereafter according to the positional relationships of the regions which are determined to include a linear pattern, interpolation regions for reprojection are selected, and for the interpolation regions thus selected the projection waveforms are analyzed.

Furthermore, in the invention, in association with the extraction of the linear segments, for each region the standard deviation of the projection waveform in the line direction determined before is obtained and utilized to determine whether or not the object to be recognized therein is a branch. When it is determined that a region has a branch, the region is further divided into smaller parts, and for each of the smaller parts the projection waveforms are analyzed in the same manner. Thus, the branch can be accurately detected with the smoothing effect maintained unchanged. In order to detect the branch with high accuracy, the region should be divided into smaller parts in such a manner that each of the smaller parts overlaps with the smaller parts adjacent thereto.

BRIEF DESCRIPTION OF THE DRAWINGS

FIG. 1 is an explanatory diagram for a description of the fundamental technical concept of this invention. FIG. 2 is an explanatory diagram showing two methods of obtaining a rotated slit region. FIG. 3 is an explanatory diagram showing examples of images obtained according to a flying spot method. FIG. 4 is an explanatory diagram for a description of a method of correction which is employed in the case where image data is directional. FIG. 5 is an explanatory diagram for a description of one

example of an operation of obtaining a line width W . FIG. 6 is an explanatory diagram for a description of a method of interpolating line lacks by overlapping. FIG. 7 is an explanatory diagram for a description of a method of interpolating line lacks according to an interpolation position determining method/ FIG. 8 is an explanatory diagram for a description of extracting a linear segments in a region including a branch. FIGS. 9 and 10 are explanatory diagrams showing examples of the classification of projection waveform patterns for decision of the presence of a branch. FIG. 11 is a block diagram showing the arrangement of an apparatus for practicing the method according to the invention. FIG. 12 is a flow chart for a description of one example of the operation of the apparatus shown in FIG. 11. FIG. 13 is an explanatory diagram for a description of a method of reading data from an original image memory. FIG. 14 is an explanatory diagram for a description of one example of a method of obtaining projection waveforms using one example of a slit. FIG. 15 is a perspective view showing a measuring vehicle for detecting cracks in a road surface. FIG. 16 is an explanatory diagram outlining a method of forming the image of cracks in a road surface. FIG. 17 is an explanatory diagram showing the scattering of a laser beam. FIG. 18 is an explanatory diagram showing images data stored in an image memory.

BEST MODE FOR CARRYING OUT THE INVENTION

Embodiments of this invention will be described with reference to the accompanying drawings.

First, the fundamental technical concept of one embodiment of the invention will be described with reference to FIG. 1.

Let us consider an image which, as shown in the part (a) of FIG. 1, is made up of 256 picture elements x 256 picture elements including a linear pattern LP. In this case, each picture element consists of 8 bits for instance, and it is multi-density data capable of representing 1 through 256 gradations. As indicated by the broken line in the part (a) of FIG. 1, 4x4 square slits are applied to the image, so that the latter is divided into 4x4 square mesh regions. Then, as shown in the part (b) of FIG. 1, the projection waveforms of the divided mesh regions (hereinafter referred to as "slit regions", when applicable) are obtained in the X-direction and in the Y-direction. In this case, the projection waveform values S_x and S_y are represented by $\sum D_i/n$ (D_i is the density data). If it is assumed that the linear pattern is larger in density than the background, the projection waveform values of the region of the linear pattern are larger than those of the other regions as shown in the part (b) of FIG. 1.

Next, in each slit region, the slit is repeatedly turned about the slit center through a predetermined angle in the range of 0 to 90°, and the projection waveforms thereof are obtained every turn of the slit. There are available two methods of obtaining the projection waveforms of the slit thus turned; in the first method, the slit is turned with the image fixed, and in the second method, the image is turned in the opposite direction with the slit fixed, as shown in FIG. 2. In the two methods, the resultant projection waveforms are the same. The term "slit" as used herein is intended to mean what is used to recognize the

region for projection waveform calculation. In obtaining the slit projection waveforms, irrespective of the rotation of the slit (or image) the average densities of picture trains in parallel with the sides of the slit are obtained. In this case, the dots of the slit region turned do not coincide with those of the image before turned. Therefore, the densities of the dots of the slit region turned are determined by the interpolation of obtaining the weighted mean of the densities of four picture elements, for instance, surrounding each dot.

When the projection waveforms are obtained every angle of rotation, then the projection waveform along the linear pattern LP is such that, as shown in the part (c) of FIG. 1, its peak P becomes maximum when the slit turns through a predetermined angle θ , whereby the linear pattern existing direction θ can be determined.

It is determined according to the value of the peak P whether or not the linear pattern is truly located in the line direction θ thus obtained.

For instance, the peak value P is compared with a predetermined threshold value P_{th} :

When $P \geq P_{th}$, it is determined that the linear pattern is located in the line direction, and

When $P < P_{th}$, it is determined that the linear pattern is not located in the line direction.

The threshold value P_{th} is determined according to the following equation (1) for instance:

$$P_{th} = \alpha \cdot S_{av} + \beta \quad (\alpha \geq 1) \text{ ----- (1)}$$

where S_{av} is the average density of the entire image (256 x

256 picture elements), and α and β are the weight coefficient and the correction coefficient which have been obtained through experiments, respectively.

Next, the line width W of the linear pattern is determined as follows: That is, as shown in the part (c) of FIG. 1, with the projection waveform processed with a predetermined threshold value Thd_1 , the length of the cut line of to the peak is the line width W . The threshold value Thd_1 may be the above-described threshold value P_{th} which is used for determination of whether or not the linear pattern is located in the line direction, or it may be set to a suitable value other than those.

The length L of the linear pattern is determined as follows: As shown in the part (d) of FIG. 1, the width of the slit region is limited to the crack width W which has been detected, and the projection waveforms of the slit region thus limited are obtained. The projection waveform along the length of the slit region is processed with a predetermined threshold value Thd_2 , so as to determined the linear pattern length L in the slit region. This is based on the fact that, with a simple square slit, the waveform along the line shows the peak clearly, while in the waveform in the widthwise direction the peak is low in contrast. The threshold value Thd_2 may be, for instance, the above-described threshold value P_{th} used for determination of whether or not the linear pattern is located in the line direction, or it may be the average density S_{av} of the entire image.

By analyzing the projection waveform in the above-described manner, the linear patter in one slit region can be recognized as

a rectangular pattern the width W , length L and direction θ of which have been known, as shown in the part (e) of FIG. 1. This pattern will be referred to as "a linear segment", when applicable. When all the mesh regions in the part (a) of FIG. 1 are processed in the above-described manner, then for each mesh region, the linear segment whose width W , length L and location θ are known can be obtained.

For determination of the above-described direction θ , linear width W and the presence or absence of a line, a standard deviation σ may be employed.

In this case, when the slit region is repeatedly turned through a predetermined angle, the standard deviation σ of the projection waveforms is obtained for each slit region turn, and the angle of rotation θ provided when the standard deviation becomes maximum is determined as the line direction.

In order to determine the presence or absence of a line in the direction thus determined, the standard deviation of the projection waveform in the direction θ is compared with a predetermined threshold value σ_{th1} :

When $\sigma \geq \sigma_{th1}$, a line is present; and

when $\sigma < \sigma_{th1}$, no line is present.

The threshold value σ_{th1} is determined according to the following equation (2) for instance:

$$\sigma_{th1} = \Gamma \cdot \sigma_{av} + \delta \quad (\Gamma \geq 1) \text{ ----- (2)}$$

where σ_{av} is the average of the standard deviations of the projection waveforms obtained with the meshes of the entire image, and Γ and δ are the weight coefficient and the correction coefficient, respectively, which are obtained through experi-

ments.

As was described above, the line direction θ is obtained from the slit turn angle provided when the standard deviation of the projection waveform becomes maximum. However, in the case where the invention is applied to the road surface image measurement which has been described with reference to FIGS. 15 through 18, it is preferable to perform the following correction: The road surface image measurement is based on the principal of the flying spot method in which a laser beam scans a road in such manner that it go across the road, and it is so designed that the unevenness is emphasized in the road crossing direction because of the geometrical positional relationship between the laser and the detector. The part (a) of FIG. 3 shows the state of a road surface. When a crack CR and large recesses g in the part (a) of FIG. 3 are image-formed by the flying spot method, they appear as shown in the part (b) of FIG.3; that is, the crack CR and the recesses g are elongated laterally. In the part (b) of FIG. 3, reference character m designates the shadows of very small recesses. Hence, the standard deviation of the projection waveform in the road crossing direction is larger than that of the projection waveform in the direction of longitudinally traversing the road. Therefore, in order to obtain a crack direction from the standard deviation, the correction should be provided depending on the direction.

As for the correction, as shown in the parts (a) and (b) of FIG. 4 for each projection slit region not turned, the standard deviations $\sigma_x(i, j)$ and $\sigma_y(i, j)$ in the horizontal direction and

in the vertical direction of the image are obtained, and the average values σ_x and σ_y of them with respect to the entire image are obtained according to the following equations (3) and (4):

$$\sigma_x = \Sigma\Sigma\sigma_x(i,j)/(4 \times 4) \text{ ----- (3)}$$

$$\sigma_y = \Sigma\Sigma\sigma_y(i,j)/(4 \times 4) \text{ ----- (4)}$$

Next, the slit is turned through an angle θ , and the estimated value $\sigma(\theta)$ of the standard deviation of the projection waveform in that direction is obtained according to the following equation (5) with the average values σ_x and σ_y distributed proportionally with the angle of rotation θ :

$$\sigma(\theta) = ((90 - \theta) \sigma_x + \theta \sigma_y)/90 \text{ -----(5)}$$

Then, the standard deviation σ of the slit projection waveform is normalized according to the following equation 6 by using the estimated standard deviation $\sigma(\theta)$ with the θ as a variable:

$$\epsilon = \sigma/(\sigma(\theta)) \text{ ----- (6)}$$

In the above-described equation, $\sigma(\theta)$ and σ are obtained with one and the same angle of rotation.

The value ϵ of each angle of rotation is obtained, and the angle of rotation θ provided when the value ϵ becomes maximum is determined as the crack direction. In this case, the crack direction can be determined without being affected by the directivity of the measured image.

After the crack existing direction θ is obtained, the presence or absence of the crack is determined as follows: That is, only when the normalized standard deviation ϵ is equal to or higher than 1 for instance, it is determined that the crack exists. The value one (1) has been obtained experimentally and statistically, and it can be represented by the following general

equation:

$$\epsilon = \sigma / \sigma_{av} = \Gamma + \delta / \sigma_{av}$$

$$(\epsilon = 1 \text{ when } \Gamma = 1 \text{ and } \delta = 0)$$

That is, only when it is larger than the average waveform dispersion attributing to the noise components of the image, it is determined that there exists an object.

The line width W may be determined according to a procedure shown in FIG. 5. That is, the projection waveform in the direction θ is processed with the threshold value $(P - \Delta P)$ which is obtained by subtracting ΔP from its peak value P , and the standard deviation σ is obtained with respect to the waveform which is formed by replacing the part larger than the threshold value $(P - \Delta P)$ with the value $(P - \Delta P)$. When the σ meets the following condition, then the length of the cut line of the peak is selected as the line width W :

$$\sigma \leq \sigma_{th2} \quad (\sigma_{th2} \text{ is the width determining threshold value})$$

However, when $\sigma > \sigma_{th2}$, then the processing is carried out with a threshold value $(P - 2\Delta P)$. The same processing is performed repeatedly until the condition $\sigma \leq \sigma_{th2}$ is satisfied. And the length of the cut line of the peak is employed as the line width W . The step ΔP of the threshold value may be for instance the quantized step (one gradation per 256 gradations) of a digital image, and the threshold value σ_{th2} may be the above-described threshold value $\sigma_{th1} (= \Gamma \sigma_{av} + \delta)$. In determining the line width, the threshold value σ_{th2} should be corrected by the normalization described with reference to FIG. 4, because the line width W can be determined more accurately independently of the

effect of the directivity of the measured image.

In addition, the line width W may be determined as follows: The average value of the waveforms processed with a threshold value $(P - i/P)$, where $i = 1, 2, \dots$ is obtained. And the processing substantially equal to that which has been described above is carried out until the average value becomes lower than a predetermined threshold value, so that the length of the cut line of the peak provided when the condition is met is employed as the line width W .

Now, let us consider the recognition of a linear pattern LP as shown in the part (a) of FIG. 6. When, with a 4x4 square mesh as shown in the part (b) of FIG. 6 as a slit region, the analysis is carried out in the above-described manner with each dot as a slit rotation center, the linear pattern is often recognized as discontinuous linear segments as shown in the part (c) of FIG. 6. This is due to the fact that, when each slit is turned, parts not included by the slit region occur in the vicinity of the slit's boundary. Therefore, even if a line exists in the parts, the resultant image is incomplete. In order to eliminate this difficulty, in the embodiment, as shown in the part (d) of FIG. 6 the slit rotation centers are arranged at intervals of a half ($1/2$) of the slit length with the slit length maintained unchanged, so that the projection regions are overlapped with one another. In this case, the resultant image is provided as continuous linear pattern as shown in the part (e) of FIG. 6.

Thus, all the parts of the linear pattern can be recognized with the slit projection positions overlapped completely. In this connection, the operating time can be reduced by a method as

shown in FIG. 7.

In the method, first for a linear pattern LP as shown in the part (a) of FIG. 7, a coarse slit projection is carried out without overlapping as shown in the part (b) of FIG. 7, thereby to detect linear segments as shown in the part (c) of FIG. 7. And at each interpolation position, a projection is performed again. For instance in the case where, in the part (d) of FIG. 7, linear patterns are detected with the slits A and B, then the reprojection is performed with the position i. Similarly, when linear patterns are detected with the slits A and C, the reprojection is performed with the position j; and when linear patterns are detected with the slits A and D, the reprojection is carried out with the position k. In this case, the reprojection is carried out at the three positions as shown in the part (e) of FIG. 7, and a continuous linear pattern as shown in the part (f) of FIG. 7 is obtained through the reprojections. Thus, the method can reduce the operating time with the detecting capacity maintained unchanged.

For instance in the case where the overlap method shown in FIG. 6 is employed, the projection is carried out 49 (7×7) times; whereas in the case where the interpolation method shown in FIG. 7 is used, it is carried out only 19 ($4 \times 4 + 3$) times.

Now, a branch determining method and a slit projection method in the case where a linear pattern has a branch will be described.

If, in the case where a linear pattern has a branch as shown in the part (a) of FIG. 8, the slit size is large, the rectangu-

lar linear segment obtained through recognition is as shaded in the part (b) of FIG 8; that is, sometimes it is impossible to clearly express the branch. This difficulty may be overcome by decreasing the slit size. However, if the image is processed, in its entirety, with the slit size reduced, then in proportion to the slit size the smoothing effect of the projection is decreased, so that noises are recognized erroneously. Therefore, in the embodiment, it is determined whether or not a linear pattern has a branch in each slit region, and only for the slit region having a branch the reprojection is carried out with the slit size reduced.

With the slit turned in the line existing direction θ , the projection waveforms in the x- and y- directions of the slit are obtained. And the smaller of the standard deviations of those projection waveforms is represented by σ_H , and the other by σ_L . Under this condition, those standard deviations σ_H and σ_L have been investigated with respect to a variety of images, and it has been found that the images patterns in the slit regions can be classified as shown in FIG. 9 according to the standard deviations σ_H and σ_L . That is, the part (a) of FIG. 9 shows the background having no linear pattern nor branch. In this case, σ_H is small, and is substantially equal to σ_L ($\sigma_H/\sigma_L \doteq 1$). The part (b) of FIG. 9 shows a pit. In this case, σ_H is middle, and $\sigma_H/\sigma_L \doteq 1$. The part (c) of FIG. 9 shows a simple line such as a crack. In this case, σ_H is large, and therefore σ_H/σ_L is also large. The part (d) of FIG. 9 shows a branch. In this case σ_H is large, and σ_H/σ_L is one (1). These relationships are can be indicated in a $\sigma_x - \sigma_y$ coordinate system as shown in FIG. 10.

Therefore, it can be determined according to the relationships whether or not there is branch in the slit region. More specifically, the standard deviations σ_x and σ_y of the slit projection waveform in the line existing direction are obtained, and it is detected where those values are located in the graph of FIG. 10. When it is detected that they are located in the "branch" region of the graph, then it is determined that the object in the slit region is a branch. The boundaries of the regions in the graph are determined statistically and experimentally.

When it is determined by the above-described method that a slit region has a branch, then a slit which is 1/4 of the initial slit (shown in the parts (a) and (b) of FIG. 8) is used for it, and the reprojection is carried out with the projection regions overlapped turning about the dots shown in the part (c) of FIG. 8. With the reprojection, the branch pattern as shown in the part (a) of FIG. 8 can be recognized as the combination (logic OR) of rectangular linear segments SG_1 through SG_5 (shaded) as shown in the part (e) of FIG. 8; that is, the branch can be reproduced with high accuracy.

FIG. 11 shows the arrangement of one example of a system for practicing the above-described linear pattern recognizing method which is applied to the detection of cracks in the road surface in FIGS. 15 through 18.

The image data obtained by sampling the road surface with a predetermined pitch (for instance 1 mm) in the longitudinal direction are recorded in a VTR 10, and transferred to an image memory 11 off-line, and then recorded in a magnetic tape 12. The

image data stored in the magnetic tape 12 are inputted into a linear pattern recognizing unit 20 off-line. It is assumed in this connection that, with 256x256 picture elements as one unit, image data having 8 bits per picture element is inputted from the magnetic tape 12 into an original image memory 21.

The linear pattern recognizing unit 20 comprises: the original image memory 21 in which image data of 256x256 picture elements (one picture element: 8 bits) is stored; a slit image memory 22 for storing the image data which are read out of the original image memory 21 substantially per slit; an image rotating circuit 23 for repeatedly rotating the image data of the slit image memory 22 through a predetermined angle according to an instruction from a system controller 31 and outputting them; a rotated image memory 24 for storing the image data thus rotated; a projection waveform operating circuit 25 for reading image data from the rotated image memory 24 to obtain the projection waveforms in two directions, the x-direction and the y-direction, in a slit region; a projection waveform memory 26 for storing the projection waveforms provided with each angle of rotation; an identifying parameter operating and storing circuit 27 for operating and storing identifying parameters such as the average density S_{av} of the entire image necessary for analysis of the projection waveforms, and the average standard deviation σ_{av} of the entire image, and calculating and storing the necessary threshold value P_{th} , Thd_1 , Thd_2 , σ_{th1} or σ_{th2} ; a waveform parameter operating circuit 28 for obtaining a standard deviation σ or peak value P from the projection waveform provided with each angle of rotation, to calculate a line direction θ , line width W

and line length L ; a comparison circuit 29 for subjecting the outputs of the waveform parameter operating circuit 28 and the identifying parameter operating circuit 27 to comparison; a feature table storing circuit 30 for storing feature parameters such as a line direction θ , line width W and line length L obtained from the results of comparison; a coordinate forming circuit 33 for forming addresses (coordinates) for the original image memory 21 and a processed image memory 32; the processed image memory 32 for display which stores the binary image data of rectangular linear segments recognized; and the system controller 31 made up of MPU or the like for controlling the operations of the above-described circuit elements.

One example of the operation of the system thus organized will be described with reference to FIG. 12, a flow chart. In this connection, it is assumed that the image data of 256×256 picture elements (one picture element consisting of 8 bits) as shown in FIG. 1 is stored in the original image memory, and similarly the 4×4 square slit is applied thereto. In this case, in obtaining rotated projection waveforms, the image is rotated in the $-\theta$ direction with the slit fixed. In addition, the method of using the standard deviation σ is employed for determination of the line direction θ and for determination of the presence or absence of a line. The method described with reference to FIG. 5 is employed to determine the line width W . In determining the line length L , the peak threshold value P_{th} for determination of the presence or absence of a line is used as the threshold Thd_2 . Furthermore, the interpolation method described with reference to

FIG. 7 is employed so as to detect a linear pattern in its entirety.

Before analyzing the projection waveforms of an image rotated, the system controller 31 operates to obtain identifying parameters such as an average density S_{av} and an average standard deviation σ_{av} (Step 100). The system controller 31 controls the coordinate forming circuit 33 to output a memory address so that image data corresponding to a slit region are transferred from the original image memory 21 into the slit image memory 22. In the identifying parameter operation, the image rotating circuit 23 operates to cause the data stored in the slit image memory 22 to be stored in the rotated image memory 22 without rotation. The projection waveform operating circuit 25 reads the not rotated image data from the rotated image memory 24, obtains the x-direction and y-direction projection waveforms in the slit region in the manner described with reference to the part (b) of FIG. 1, and stores the resultant projection images in the projection waveform memory 26. The waveform parameter operating circuit 28 obtains the average density $d(1,1)$ and standard deviations $\sigma(1,1)$ according to the contents of the projection waveform memory 26. This operation is carried out for all the slit regions (not overlapped). That is, the waveform parameter operating circuit 28 obtains the average densities $d(1,1)$, $d(1,2)$and $d(4,4)$ and the standards deviations $\sigma(1,1)$, $\sigma(1,2)$and $\sigma(4,4)$ of all the slit regions (cf. the part (b) of FIG. 4). These average densities and standard deviations are applied to the identifying parameter operating circuit 27, where they are averaged to provide the average density S_{av} and average

standard deviation σ_{av} of the entire original image. The identifying parameter operating circuit 27 stores those average values S_{av} and σ_{av} , and obtains the peak threshold value P_{th} and the standard deviation threshold value σ_{th1} , which are used for analysis of the projection waveforms.

Next, the system controller 31 operates to analyze the projection waveforms of the rotated image. In this case, the system controller 31 operates to cause the coordinate forming circuit 33 to provide coordinates with which, as shown in FIG. 13, the image data of a slightly larger region (as indicated by the solid line) is read out of the original image memory 21; that is, when an image VD is rotated, the image data is contained in the region of the fixed slit SL (indicated by the broken line) at all times. The image data thus read is stored in the slit image memory 22. The image rotating circuit 23 operates to rotate the image data stored in the slit image memory through a predetermined angle in response to an instruction from the system controller 31, and transmits the image data thus rotated to the rotated image memory 24. In this operation, the image rotating circuit 23 carries out the above-described interpolation utilizing the weighted density means of four picture elements adjacent thereto in order to correct the shift of the grid point due to the rotation. The projection waveform operating circuit 25 reads the stored data from the rotated image memory 24, to obtain x-direction and y-direction projection waveforms in the slit region in the manner described with reference to the part (b) of FIG. 1 and causes the projection waveform memory 26 to store the projec-

tion waveforms thus obtained. Thereafter, the system controller 31 applies the next angle of rotation to the image rotating circuit 23. And the same operations are carried out, so that the projection waveforms with the angle of rotation are stored in the projection waveform memory 26. The above-described operations are performed repeatedly until the image has been rotated stepwise in the range of 0° to 90° , so that the projection waveforms with all the angles of rotation are stored in the projection waveform memory 26.

According to the projection waveforms with all the angles of rotation which have been stored in the projection waveform memory 26, the following operation is carried out, to recognize a crack or branch as a linear segment.

First, the waveform parameter operating circuit 28 uses the projection waveforms with all the angles of rotation which have been stored in the projection waveform memory 26, to obtain the standard deviation σ for each angle of rotation, and reads the average standard deviations σ_x and σ_y in the x-direction and y-direction of the whole image from the identifying parameter operating and storing circuit 17, to obtain the estimated standard deviation $\sigma(\theta)$ for each angle of rotation, and utilizes these calculated values σ and $\sigma(\theta)$ to obtain the normalized standard deviation $\epsilon (= \sigma/\sigma(\theta))$, and determines as the line direction the angle of rotation θ provided when the value ϵ becomes maximum. Thus, by determining the line direction in the above-described manner, the crack direction can be determined correctly without being affected by the directivity of the image measured in the flying spot method. The angle of rotation θ thus determined is

stored in the feature table storing circuit 30. The waveform parameter operating circuit 28 applies the value ϵ corresponding to the angle of rotation θ thus determined to the comparison circuit 29, to which a value "1" for instance has been applied by the identifying parameter operating circuit 27. The comparison circuit 29 subjects these values ϵ and "1" to comparison, and applies the result of comparison to the feature table storing circuit 30. The system controller 31 determines it from the result of comparison that there is a crack when $\epsilon \geq 1$.

In the case where the presence of a crack is determined, the system controller 31 operates to detect a line width W and a line length as follows:

The determination of the line width W is achieved by the method described with reference to FIG. 5. That is, the waveform parameter operating circuit 28 obtains the peak value P of the projection waveform in the crack existing direction θ , processes it with a threshold value $(P - \Delta P)$, obtains a standard deviation σ concerning the waveform which is obtained by replacing the part larger than the threshold value $(P - \Delta P)$ with the value $(P - \Delta P)$, and applies the standard deviation thus obtained to the comparison circuit 29. In this operation, the comparison circuit 29 has receives a width determining threshold value σ_{th2} from the identifying parameter operating circuit 27 (in this case, instead of σ_{th2} , the threshold value $\sigma_{th1} (= \Gamma \sigma_{av} + \delta)$ for determining the presence or absence of a linear object being used). The comparison circuit 29 subjects those values σ and σ_{th2} to comparison, and applies the result of comparison to the feature table storing

circuit 30. When $\sigma \leq \sigma_{th2}$, the system controller 31 applies an instruction signal to the waveform parameter operating circuit 28 to cause the latter to obtain the length of the cut line of the peak at that time, and causes the feature table storing circuit 30 to store it as a line width W . In the case where $\sigma > \sigma_{th2}$, the system controller operates in the same manner with a threshold value $(P - 2/P)$. That is, the above-described operation is carried out repeatedly until $\sigma \leq \sigma_{th2}$ is satisfied. The length of the cut line of the peak provided when the condition is satisfied is regarded as the line width W , and it is stored in the feature table storing circuit 30. If, in this case, the threshold value σ_{th2} is subjected to directional correction by the above-described normalization, then the line width W can be detected with higher accuracy.

In order to determine the line length L , the system controller 31 reads the image data of the region which is limited to the line width W only in the direction of line width, out of the image data stored in the slit image memory 22, and causes the image rotating circuit 23 to rotate it through $-\theta$. The image data thus rotated is stored in the rotated image memory 24. The projection waveform operating circuit 25 obtains the x-direction and y-direction projection waveforms of the image data, and applies them to the projection waveform memory 26 so that they are stored therein. The waveform parameter operating circuit 28 uses a threshold value $T_{th2} (= P_{th} = \alpha \cdot S_{wh} + \beta)$ read out of the identifying parameter operating and storing circuit 27, to process one of the x-direction and y-direction projection waveforms, which is different in direction from the projection waveform

whose peak has been obtained, to determine the line length L , and applies the line length to the feature parameter storing circuit 30 so that it is stored therein. In the above-described manner, the width W , length L and direction θ of the linear pattern in a slit region are detected, and they are stored in the feature table storing circuit 30 (Steps 110 and 120). In the case where, after the direction θ is determined, it is determined that no line exists, the operations of determining the line width W and the line length L are not carried out, and the projection waveforms of the next slit regions are analyzed.

Next, the system controller 31 operates according to the method described with reference to FIGS. 9 and 10, to determine whether the image recognized in the slit region is a line, or a branch, or others (Steps 130 and 140). When it is a simple linear pattern, the system controller 31 operates to write the rectangular linear segment, which is defined by the line width W , line length L and direction θ stored in the feature table storing circuit 30, in the corresponding region in the processed image memory 32. In this operation, when the linear segment thus recognized is written in the processed image memory 32, its rotated angle is corrected, so that the image data in the original image memory 21 correspond to those stored in the processed image memory.

When, on the other hand, the object is determined as a branch, the system controller 31 operates to subdivide the image data of the slit region stored in the slit image memory 22 by overlapping in the manner described with reference to FIG. 8, and

to make analysis for each of the image data thus subdivided with respect to the rotated projection waveforms thereof similarly as in the above-described case (Step 150). The feature parameters (direction θ , width W and length L) of the subdivided regions are stored in the feature table storing circuit 30 (Step 160). According to those feature parameters, the system controller operates to reconstruct the linear segment in the slit region, and to write it in the corresponding region in the processed image memory 31. Thus, an intricate branch pattern can be reproduced with high accuracy.

The above-described operations are carried out for all of the 4x4 slit regions (Step 180), the linear pattern stored in the original image memory 21 is reproduced as the sum (OR) of the rectangular linear segments in the processed image memory 32.

Next, the system controller 31 operates to reproduce a line pattern completely. First, the system controller 31 identifies, of the 4x4 slit regions, the region in which a linear object exists, and determine, in response to the identification, an interpolation position for reprojection in the manner described with reference to the part (e) of FIG. 7 (Step 190) And the system controller 31 reads the image data from the original image memory which corresponds to the one interpolation position thus determined, and operates to analyze the image data thus read with the projection waveform rotated similarly as in the above-described case. The results of analysis (W , L and θ) are stored in the feature table storing circuit 30 (Step 200). The system controller 31 writes the rectangular linear segment defined by the feature parameters (W , L and θ) in the corresponding interpo-

lation position in the processed image memory 32. The above-described operation is carried out for all the reprojection interpolation positions (Step 220), as a result of which a rectangular linear pattern which is continuous as one linear pattern is reproduced in the processed image memory 32.

In the above-described method, in the case where the original image has no linear pattern at all, or noises are superposed on the original image, noises may be detected from other than lines even if the identifying parameters such as a total average standard deviation σ_{av} necessary for processing are determined from the original image data. However, such noises appear individually, being not connected to one another. For instance in detecting a road surface for cracks, the road surface is made uneven because of aggregate (small pebbles) in the asphalt concrete, and the uneven parts are observed dark similarly as in the case of a crack in the road surface. However, the uneven parts are not connected to one another, occurring individually. Hence, such noises can be separated from the linear object by removing the linear segments detected individually.

According to the above-described embodiment,

(1) The memory region is divided into a plurality of square regions, and for every square region the projection waveforms are obtained. And the square region is repeatedly rotated through a predetermined angle to obtain projection waveforms in a plurality of directions. These projection waveforms are analyzed to recognize a linear pattern as a rectangular linear segment. Therefore, intricate lines such as cracks can be recognized with high

accuracy.

(2) The identifying parameters such as average densities and average standards deviations are determined according to the image data stored in the original image memory. Therefore, even if the image data are fluctuated in density or in background noise, the line recognizing operation is stably carried out at all times.

(3) It is unnecessary to use a standard pattern such as a line detecting matching pattern. That is, since such a standard pattern is not used, the recognition of a linear pattern is not limited by the width, length and direction thereof.

(4) Even if a linear pattern to be recognized is locally changed in width or direction, its projection waveforms can be analyzed without intricate operation, whereby it can be readily recognized as a linear segment.

(5) The slit regions are defined in such a manner as to overlap with the adjacent ones. This will eliminate the difficulty that a line is not completely detected when the image or the slit is rotated.

(6) First, with the image data divided coarsely, the projection waveforms are analyzed, and then an interpolation region to be reprojected is determined according to the positional relationship of the region which has a linear pattern. And only for the region thus determined, the projection waveform analysis is carried out. Hence, the operating time is greatly reduced, and the difficulty can be positively prevented that a line is not completely detected.

(7) In the case of directional image data, correction is

made according to the directivity of the image data to determine the line existing direction and the line width. Hence, even when directional background noises are included, or the image (density and contrast) of a linear object differs depending on directions, the line direction and width can be accurately detected. Furthermore, the background noises will not be recognized as linear objects; that is, the line detecting operation is carried out with high stability.

(8) The presence or absence of branch is detected, and only for the region having the branch, the slit dividing operation is carried out, and the reprojection waveforms thereof are analyzed to extract a linear segment. Hence, the branch can be accurately detected with the averaging effect maintained unchanged.

The invention is not limited to the above-described embodiment; that is, it can be changed or modified. For instance, the method of obtaining projection waveforms in different projection angles may be modified as follows: In the case of an octagonal slit as shown in FIG. 14, the projection waveforms in three directions can be obtained without rotation of the slit or the image. In addition, the number of division and the configuration of the slit are optional. Furthermore, if, after analysis, the centers of the linear segments are extracted and connected with a line, then a linear pattern having no line width can be reproduced.

In the above-described embodiment, for a directional image, the estimated standard deviation $\sigma(\theta)$ is obtained by the linear interpolation that the average standard deviations σ_x and σ_y are

proportionally distributed with respect to angle θ , and the standard deviation σ is normalized according to the value $\sigma(\theta)$, whereby the image directional in one direction is processed as in the case of an image according to the flying spot method. However, in the case where noises are intricate in directivity as in the case of detecting cracks in a metal surface or tears in a paper or cloth surface in which fibers are extended in a number of directions, instead of the above-described estimated value $\sigma(\theta)$, a non-linear function $f(\theta, \sigma_x, \sigma_y)$ consisting of three variables θ , σ_x and σ_y may be used to normalize the standard deviation σ . The above-described directivity correction by the linear interpolation may be applied not only to the image obtained by the flying spot method, but also to the image provided by an image-pickup element which has noises in one direction as in the case of the image obtained by scanning with a CCD line sensor and to the image of the object whose material itself is directional as in the case of a wood surface or fibers.

INDUSTRIAL APPLICABILITY

The linear pattern recognizing method according to the invention can be effectively applied to recognize not only cracks in road surfaces, but also linear patterns such as cracks, tears, stripes, bends in structures such as asphalt roads, concrete roads, airport runaways, building outer walls, vertical concrete walls, and tunnel inner walls, and of industrial products such as metal plates, plastic plates and vinyl sheets, and linear patterns such as bar-shaped workpieces and introducing while lines which are visual means in robots or in conveying systems.

CLAIMS

1. A linear pattern recognizing method comprising:

a first step in which the memory region of an original image memory in which image data have been stored is divided into a plurality of smaller regions, and according to the image data in said plurality of regions, projection waveforms at a plurality of different projection angles are obtained for each of said smaller regions;

a second step of obtaining, according to said projection waveforms obtained in said first step, the line direction of a linear pattern existing in the image data of each of said smaller regions;

a third step of determining, according to said projection waveforms obtained for said smaller regions in said first step, whether or not a linear pattern exist in the image data of each of said smaller regions;

a fourth step of obtaining, according to said projection waveforms obtained for said smaller regions in said first step, the line width of a linear pattern existing in the image data of each of said smaller regions;

a fifth step of obtaining, according to said projection waveforms obtained for said smaller regions in said first step, the line length of a linear pattern existing in the image data of each of said smaller regions; and

a sixth step of extracting, according to the results of operations in said second through fifth steps, extracting a linear segment corresponding to a linear pattern existing in the image data of each of said smaller regions.

2. A linear pattern recognizing method as claimed in claim 1, in said first step of which an $n \times m$ matrix slit is used to divide said memory region of said original image memory into a plurality of square regions.

3. A linear pattern recognizing method as claimed in claim 1, in said first step of which each projection waveform is obtained with the average value of the densities of a plurality of picture elements existing in a projection direction in each of said smaller regions as a waveform value.

4. A linear pattern recognizing method as claimed in claim 3, in said second step of which, of the projection waveforms obtained in said first step, one which has a projection angle with which a projection waveform is made maximum in peak value is selected, and the projection angle of said projection waveform thus selected is determined as the line direction of said linear pattern.

5. A linear pattern recognizing method as claimed in claim 4, in said third step of which the maximum peak value of said projection waveform in said line direction obtained in said second step is compared with a predetermined threshold value, to determine whether or not a linear pattern exists in said smaller region.

6. A linear pattern recognizing method as claimed in claim 5, in said third step of which said threshold value for determining the presence or absence of a linear pattern is set using the average density of all the image data in said original image memory.

7. A linear pattern recognizing method as claimed in claim 4, in said fourth step of which said projection waveform having the maximum peak value obtained in said second step is cut with the line of a predetermined threshold value, and the distance between the two intersections of said cutting line and said projection waveform is determined as the line width of said linear pattern.

8. A linear pattern recognizing method as claimed in claim 7, in said fifth step of which, from said image data corresponding to said projection angle providing a maximum peak value which is obtained in said second step, a part is extracted which is between two straight lines which are extended from said two intersections of said cutting line and said projection waveform which are obtained in said fourth step, with respect to said image data thus extracted a projection waveform is obtained in a direction perpendicular to said line direction, and compared with a predetermined threshold value, and the length of the part of said projection waveform which is larger than said threshold value is determined as the line length of said linear pattern.

9. A linear pattern recognizing method as claimed in claim 4, in said fourth step of which said projection waveform having a maximum peak value which is obtained in said second step is processed with a plurality of first threshold values, standard deviation are obtained for a plurality of combination waveforms which are combination of projection waveforms smaller than said first threshold values and straight lines corresponding to said first threshold values and compared with a second threshold value, so that, of said combination waveforms with which said

standard deviations are smaller than said second threshold value, one whose first threshold value is largest is selected, and the distance between the two intersections of a straight line corresponding to said first threshold value of said combination waveform and said projection waveform is determined as the line width of said linear pattern.

10. A linear pattern recognizing method as claimed in claim 9, in said fourth step of which a plurality of values which are provided by repeatedly subtracting a predetermined value from the peak value of said projection waveform are employed as said first threshold values.

11. A linear pattern recognizing method as claimed in claim 4, in said fourth step of which said projection waveform having a maximum peak value which is obtained in said second step is processed with a plurality of first threshold values, average values are obtained for a plurality of combination waveforms which are combination of projection waveforms smaller than said first threshold values and straight lines corresponding to said first threshold values and compared with a second threshold value, so that, of said combination waveforms with which said average values are smaller than said second threshold value, one whose first threshold value is largest is selected, and the distance between the two intersections of a straight line corresponding to said first threshold value of said combination waveform and said projection waveform is determined as the line width of said linear pattern.

12. A linear pattern recognizing method as claimed in claim

11, in said fourth step of which a plurality of values which are provided by repeatedly subtracting a predetermined value from the peak value of said projection waveform are employed as said first threshold values.

13. A linear pattern recognizing method as claimed in claim 1, in said first step of which the memory region of said original image memory is divided into said plurality of smaller regions in such a manner that each of said smaller regions overlap with said smaller region adjacent thereto.

14. A linear pattern recognizing method as claimed in claim 1, in which said linear segments extracted in said sixth step are rectangular.

15. A linear pattern recognizing method as claimed in claim 1, in which said linear segments extracted in said sixth step are linear.

16. A linear pattern recognizing method comprising:

a first step in which the memory region of an original image memory in which image data have been stored is divided into a plurality of smaller regions, and according to the image data in said plurality of regions, projection waveforms at a plurality of different projection angles and standard deviations for said projection waveforms are obtained for each of said smaller regions;

a second step of obtaining, according to said standard deviations of said projection waveforms obtained in said first step, the line direction of a linear pattern existing in the image data of each of said smaller regions;

a third step of determining, according to said standard

deviations of said projection waveforms obtained in said first step, whether or not a linear pattern exists in the image data of each of said smaller regions;

a fourth step of obtaining, according to said projection waveforms obtained for said smaller regions in said first step, the line width of a linear pattern existing in the image data of each of said smaller regions;

a fifth step of obtaining, according to said projection waveforms obtained for said smaller regions in said first step, the line length of a linear pattern existing in the image data of each of said smaller regions; and

a sixth step of extracting, according to the results of operations in said second through fifth steps, extracting a linear segment corresponding to a linear pattern existing in the image data of each of said smaller regions.

17. A linear pattern recognizing method as claimed in claim 16, in said second step of which said plurality of standard deviations at said plurality of projection angles which are obtained in said first step are subjected to comparison, and the projection angle providing the largest said standard deviation is determined as the line direction of said linear pattern.

18. A linear pattern recognizing method as claimed in claim 17, in said third step of which the standard deviation of said projection waveform having maximum in standard deviation which is obtained in said second step is compared with a predetermined threshold value to determine whether or not a linear pattern exists in said smaller region.

19. A linear pattern recognizing method as claimed in claim 18, in said third step of which said threshold value for determining the presence or absence of a linear pattern is set using the average value of said standard deviations of said projection waveforms which are obtained for all the smaller regions in said original image memory.

20. A linear pattern recognizing method as claimed in claim 16, in which said second step comprises:

a first process of obtaining, according to the standard deviations of projection waveforms in two-dimensional directions provided when said projection angle obtained in said first step is zero, an average value of standard deviations in two-dimensional directions in said original image memory;

a second process in which said average value of said standard deviations in two-dimensional directions which is obtained in said first process is distributed in proportion to said projection angles;

a third process in which said standard deviations of said projection waveforms at said projection angles which are obtained in said first step are normalized with the values calculated in said second process; and

a fourth process in which said standard deviations at said projection angles which have been normalized in said third process are subjected to comparison, so that, of said projection angles, one which provides a maximum normalization is determined as the line direction of said linear pattern.

21. A linear pattern recognizing method as claimed in claim 20, in said third step of which said normalization obtained in

said third process is compared with a predetermined value to determined whether or not a linear pattern exists therein.

22. A linear pattern recognizing method comprising:

a first step in which the memory region of an original image memory in which image data have been stored is divided into a plurality of smaller regions, and according to the image data in said plurality of regions, projection waveforms at a plurality of different projection angles are obtained for each of said smaller regions;

a second step of obtaining, according to said projection waveforms obtained in said first step, the line direction of a linear pattern existing in the image data of each of said smaller regions;

a third step of determining, according to said projection waveforms obtained for said smaller regions in said first step, whether or not a linear pattern exist in the image data of each of said smaller regions;

a fourth step of obtaining, according to said projection waveforms obtained for said smaller regions in said first step, the line width of a linear pattern existing in the image data of each of said smaller regions;

a fifth step of obtaining, according to said projection waveforms obtained for said smaller regions in said first step, the line length of a linear pattern existing in the image data of each of said smaller regions;

a sixth step of extracting, according to the results of operations in said second through fifth steps, extracting a

linear segment corresponding to a linear pattern existing in the image data of each of said smaller regions;

a seventh step of determining, according to the result of operation in said third step, the positional relationship of said smaller region having a linear pattern, and determining, according to said positional relationship thus determined, an interpolation position on said original image memory for reprojection;

an eighth step of obtaining projection waveforms at a plurality of different projection angles again at each interpolation position on said original image memory which is determined in said seventh step;

a ninth step of operating, according to said projection waveforms obtained in said eighth step, the presence or absence, line direction, line width and line length of a linear pattern in said interpolation region; and

a tenth step of extracting, according to the results of operation in said ninth step, a linear segment corresponding to a linear pattern which exists in each interpolation region, and combining said linear segment thus extracted with said line segment obtained in said sixth step.

23. A linear pattern recognizing method comprising:

a first step in which the memory region of an original image memory in which image data have been stored is divided into a plurality of smaller regions, and according to the image data in said plurality of regions, projection waveforms at a plurality of different projection angles are obtained for each of said smaller regions;

a second step of obtaining, according to said projection waveforms obtained in said first step, the line direction of a linear pattern existing in the image data of each of said smaller regions;

a third step of determining, according to said projection waveforms obtained for said smaller regions in said first step, whether or not a linear pattern exist in the image data of each of said smaller regions;

a fourth step of obtaining, according to said projection waveforms obtained for said smaller regions in said first step, the line width of a linear pattern existing in the image data of each of said smaller regions;

a fifth step of obtaining, according to said projection waveforms obtained for said smaller regions in said first step, the line length of a linear pattern existing in the image data of each of said smaller regions;

a sixth step of extracting, according to the results of operations in said second through fifth steps, extracting a linear segment corresponding to a linear pattern existing in the image data of each of said smaller regions;

a seventh step of obtaining for each smaller region the standard deviations of said projection waveforms in said line direction obtained in said second step and in a direction perpendicular to said line direction, and determining from said standard deviations whether or not a branch exists in each smaller region;

an eighth step of further dividing each of the smaller

regions which are determined to have branches in said seventh step into a plurality of much smaller regions, and obtaining projection waveforms at a plurality of different projection angles again for each of said much smaller regions;

a ninth step of determining, according to said projection waveforms obtained for said much smaller regions in said eighth step, the presence or absence, line direction, line width and line length of a linear pattern; and

a tenth step of extracting, according to the results of operation in said ninth step, linear segments corresponding to branches existing in said regions.

24. A linear pattern recognizing method as claimed in claim 23, in said seventh step of which, when the larger of said standard deviations in said two directions is larger in value, and the ratio of said standard deviations in said two directions is substantially equal to one, the existence of a branch in said smaller region is determined.

25. A linear pattern recognizing method as claimed in claim 23, in said eighth step of which each smaller region is divided into said plurality of much smaller regions in such a manner that each of said much smaller regions overlaps with said much smaller regions adjacent thereto.

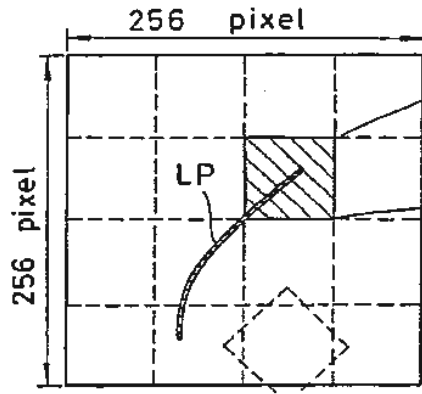

FIG. 1(a)

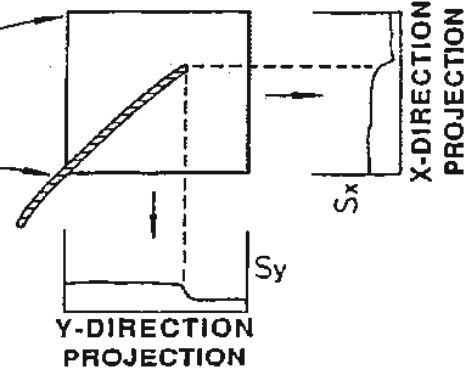

FIG. 1(b)

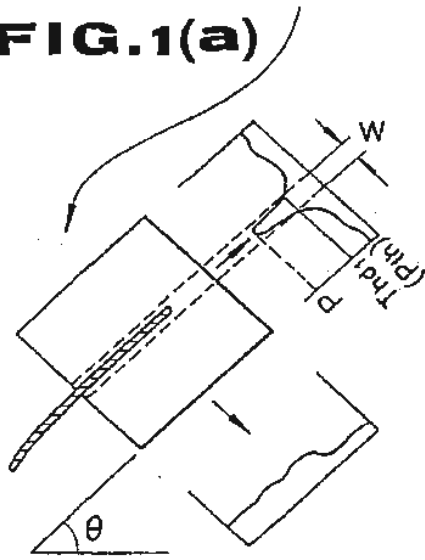

FIG. 1(c)

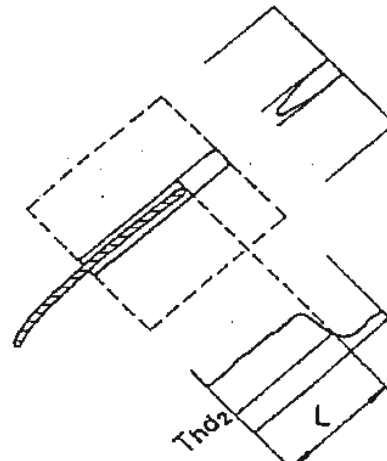

FIG. 1(d)

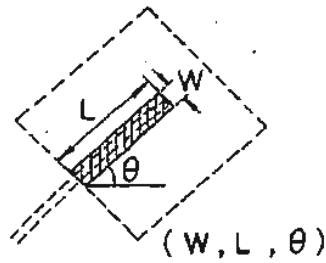

FIG. 1(e)

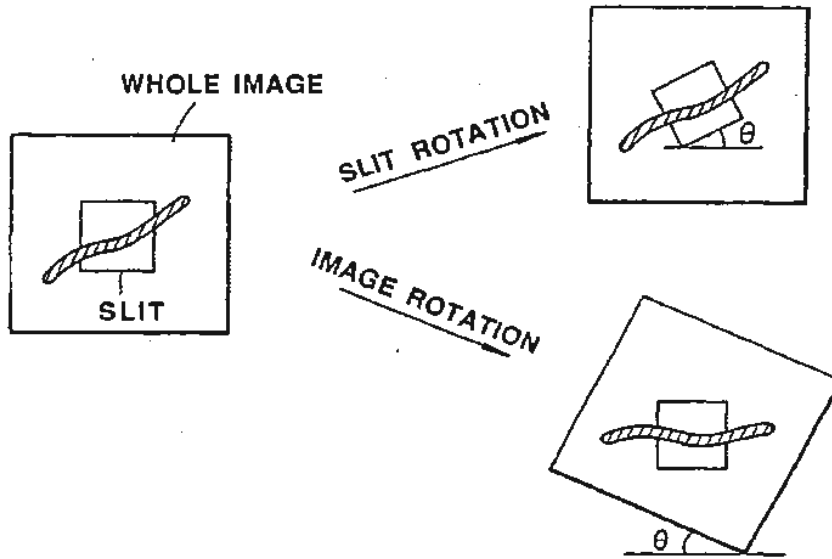

FIG. 2

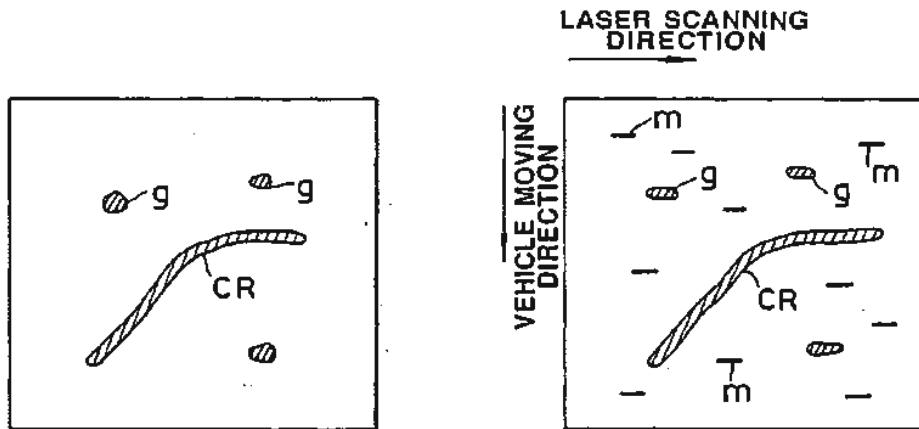

FIG. 3(a)

FIG. 3(b)

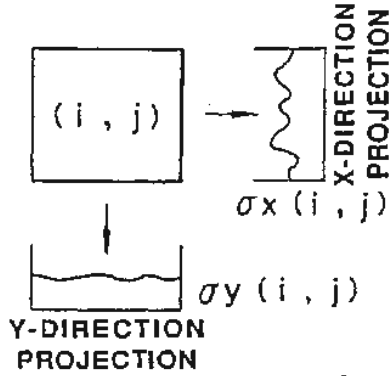

FIG. 4(a)

$\sigma_x(1-1)$ $\sigma_y(1-1)$	$\sigma_x(2-1)$ $\sigma_y(2-1)$	---	---
---	---	$\sigma_x(3-4)$ $\sigma_y(3-4)$	$\sigma_x(4-4)$ $\sigma_y(4-4)$

FIG. 4(b)

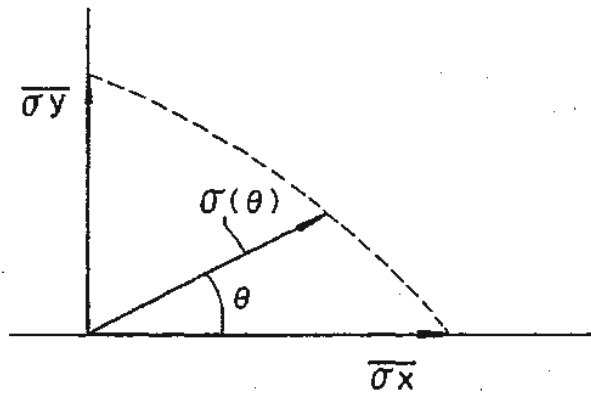
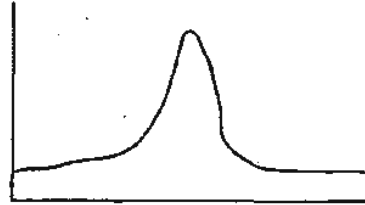

FIG. 4(c)



ORIGINAL WAVEFORM

FIG. 5(a)

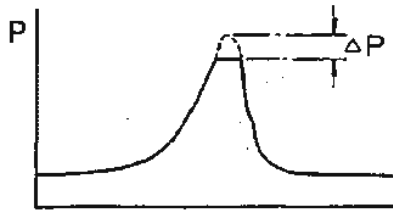

FIG. 5(b)

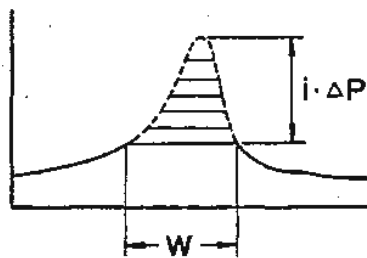

FIG. 5(c)

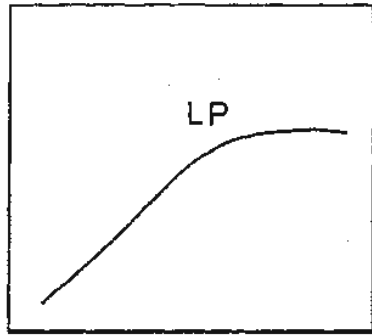

FIG. 6(a)

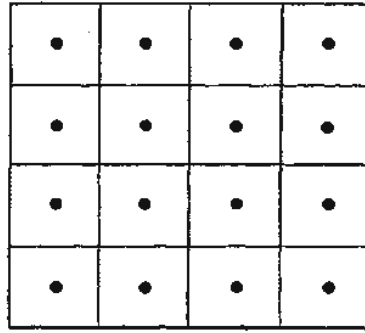

FIG. 6(b)

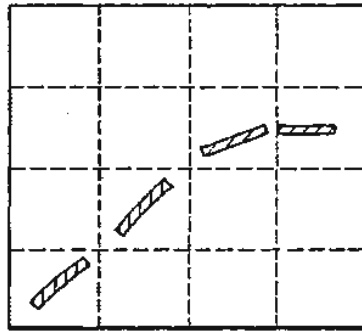

FIG. 6(c)

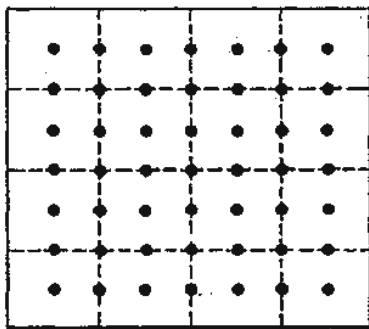

FIG. 6(d)

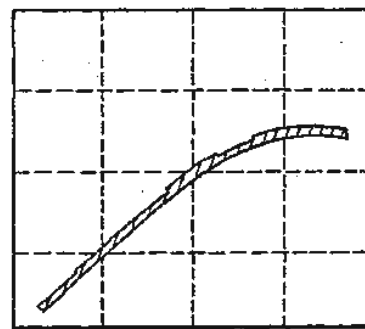

FIG. 6(e)

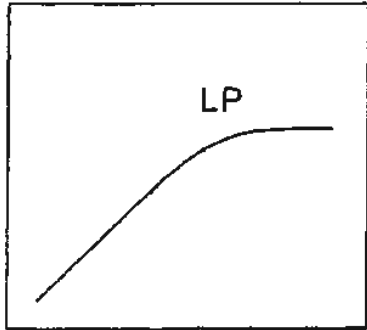

FIG. 7 (a)

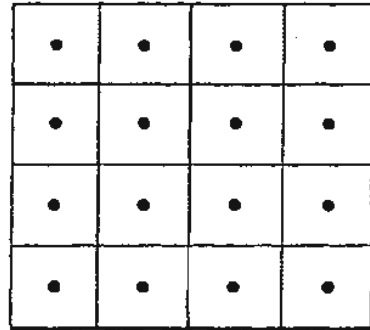

FIG. 7 (b)

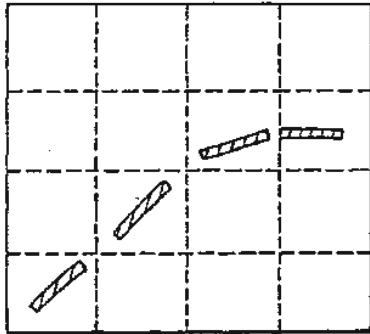

FIG. 7 (c)

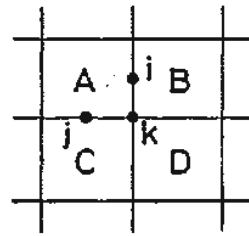

FIG. 7 (d)

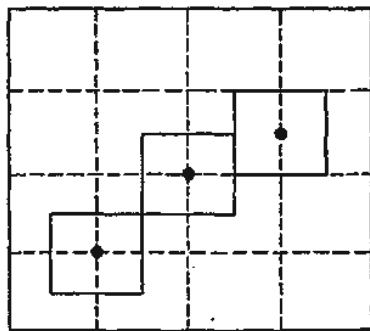

FIG. 7 (e)

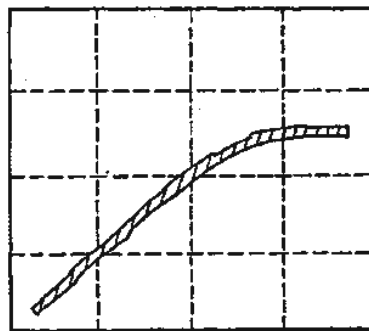

FIG. 7 (f)

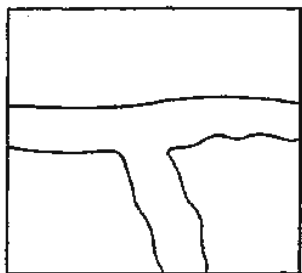

FIG. 8(a)

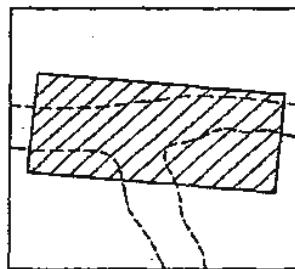

FIG. 8(b)

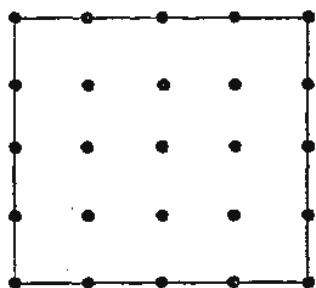

FIG. 8(c)



FIG. 8(d)

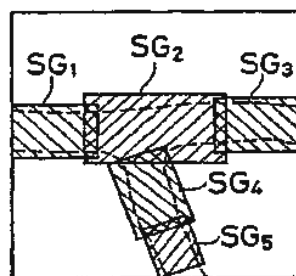

FIG. 8(e)

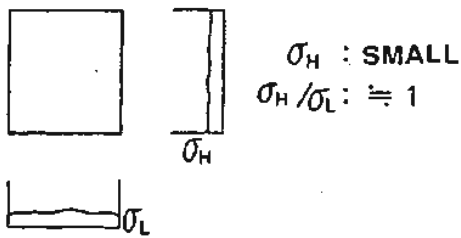

FIG. 9(a) BACKGROUND

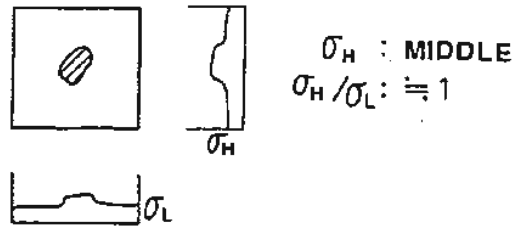

FIG. 9(b) PIT

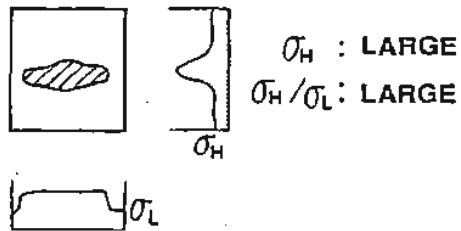

FIG. 9(c) SIMPLE LINE

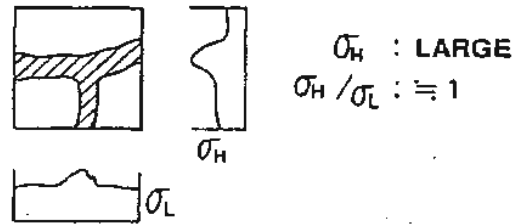

FIG. 9(d) BRANCH

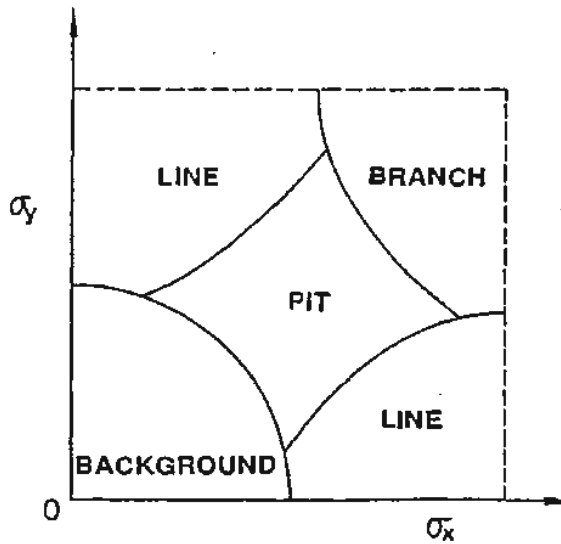

FIG. 10

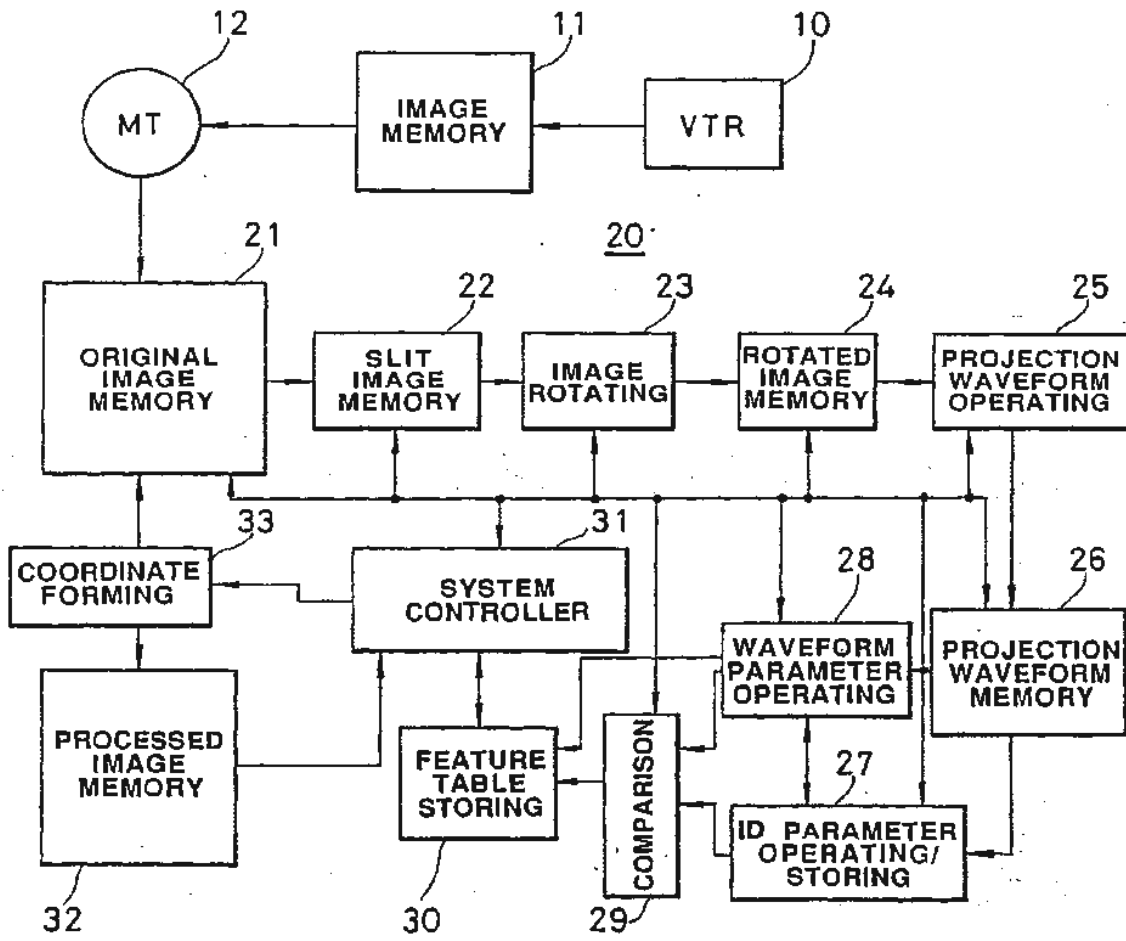

FIG.11

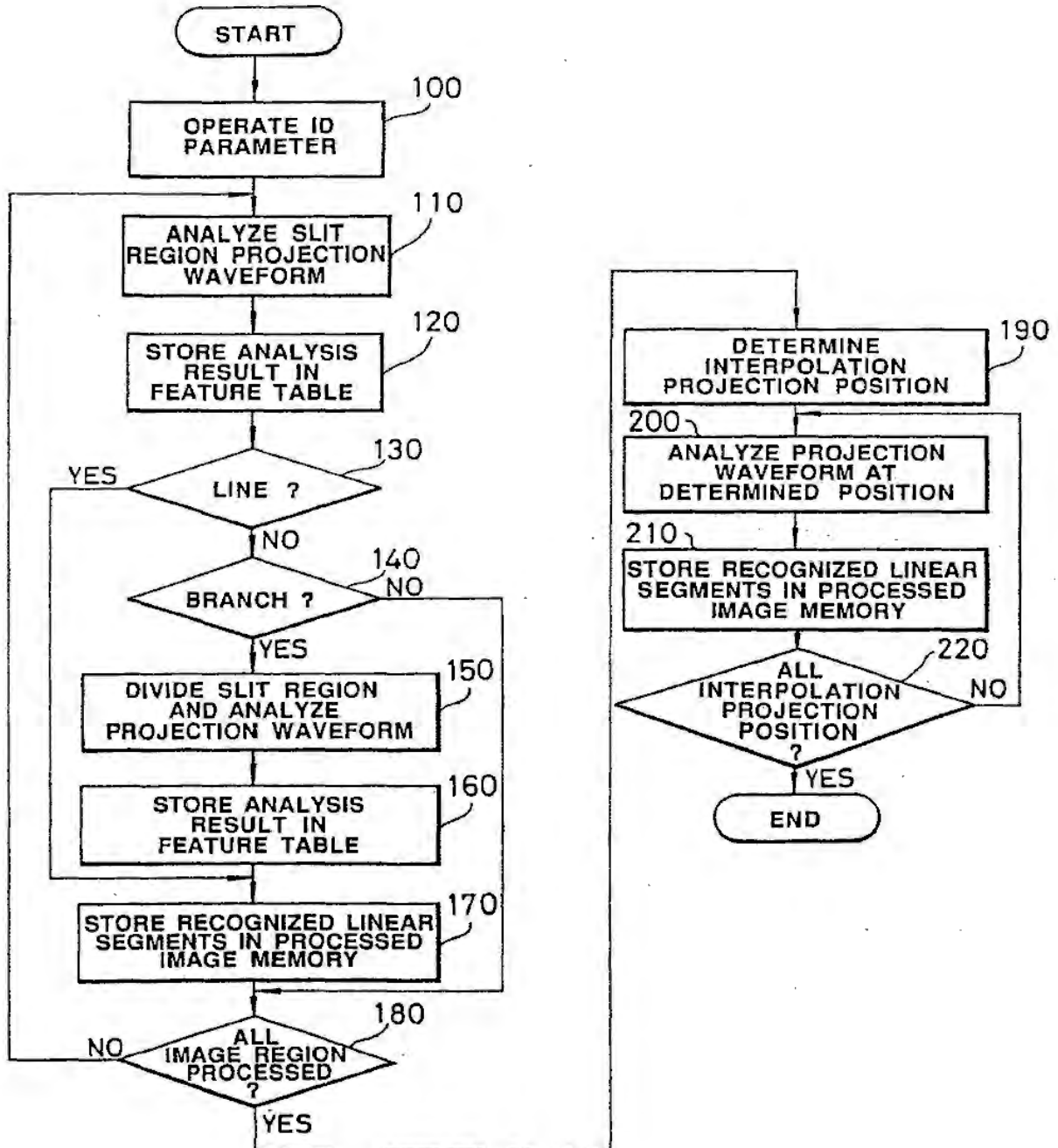

FIG.12

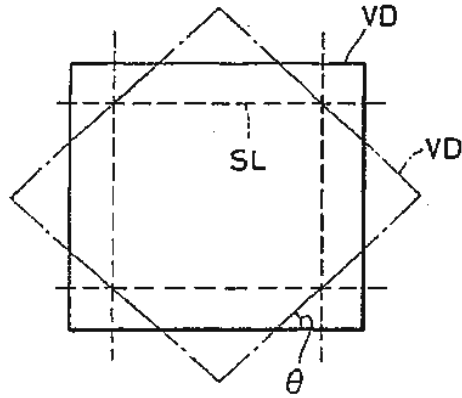

FIG.13

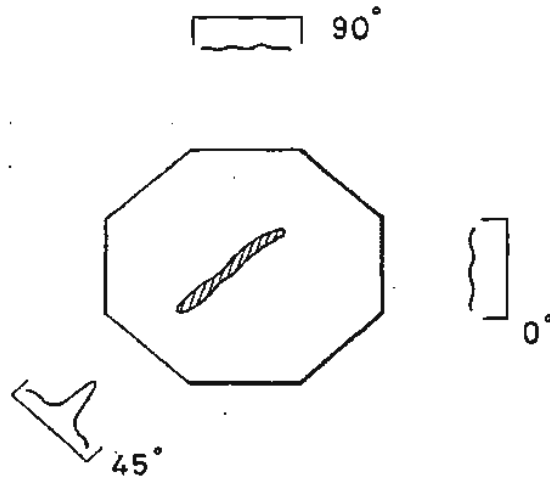

FIG.14

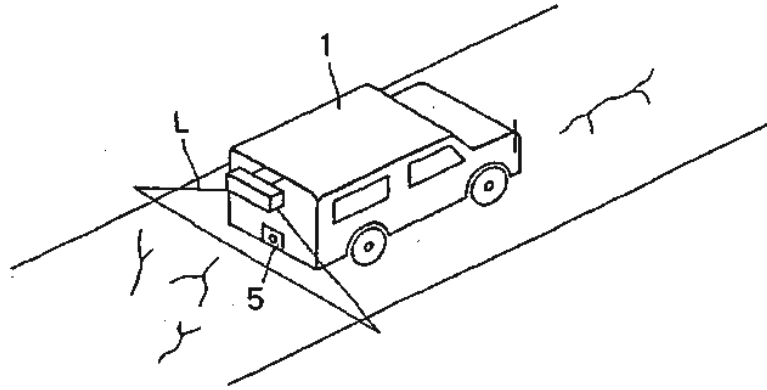

FIG. 15

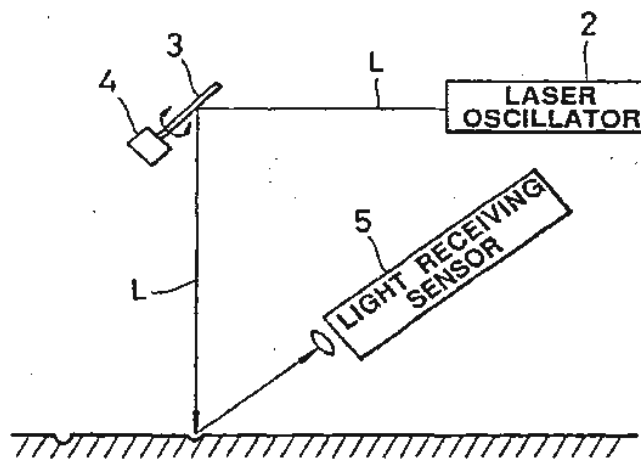

FIG. 16

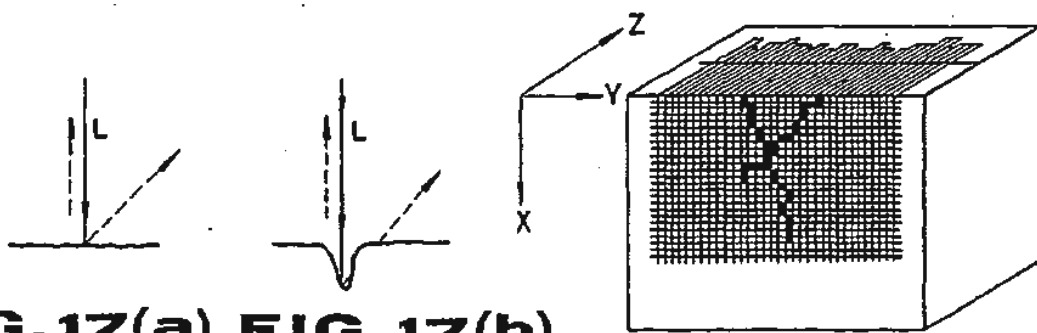

FIG. 17(a) FIG. 17(b)

FIG. 18

INTERNATIONAL SEARCH REPORT

International Application No **PCT/JP87/00735**

I. CLASSIFICATION OF SUBJECT MATTER (if several classification symbols apply, indicate all) ²		
According to International Patent Classification (IPC) or to both National Classification and IPC		
Int.Cl ⁴	G06F15/70	
II. FIELDS SEARCHED		
Minimum Documentation Searched ⁴		
Classification System	Classification Symbols	
IPC	G06F15/62-15/70, G06K9/36-9/52	
Documentation Searched other than Minimum Documentation to the Extent that such Documents are Included in the Fields Searched ⁵		
Jitsuyo Shinan Koho	1971 - 1987	
Kokai Jitsuyo Shinan Koho	1971 - 1987	
III. DOCUMENTS CONSIDERED TO BE RELEVANT ¹⁴		
Category ⁸	Citation of Document, ¹⁰ with indication, where appropriate, of the relevant passages ¹¹	Relevant to Claim No. ¹⁸
Y	JP, A, 61-193004 (Hitachi, Ltd.) 27 August 1986 (27. 08. 86) (Family: none)	1-15
Y	JP, A, 57-162059 (Fujitsu Ltd.) 5 October 1982 (05. 10. 82) (Family: none)	1-15
<p>¹ Special categories of cited documents:</p> <p>"A" document defining the general state of the art which is not considered to be of particular relevance</p> <p>"E" earlier document but published on or after the international filing date</p> <p>"L" document which may throw doubts on priority claim(s) or which is cited to establish the publication date of another citation or other special reason (as specified)</p> <p>"O" document referring to an oral disclosure, use, exhibition or other means</p> <p>"P" document published prior to the international filing date but later than the priority date claimed</p> <p>"T" later document published after the international filing date or priority date and not in conflict with the application but cited to understand the principle or theory underlying the invention</p> <p>"X" document of particular relevance: the claimed invention cannot be considered novel or cannot be considered to involve an inventive step</p> <p>"Y" document of particular relevance: the claimed invention cannot be considered to involve an inventive step when the document is combined with one or more other such documents, such combination being obvious to a person skilled in the art</p> <p>"&" document member of the same patent family</p>		
IV. CERTIFICATION		
Date of the Actual Completion of the International Search ²	Date of Mailing of this International Search Report ²	
November 2, 1987 (02. 11. 87)	November 16, 1987 (16. 11. 87)	
International Searching Authority ¹	Signature of Authorized Officer ²⁰	
Japanese Patent Office		

12 **EUROPÄISCHE PATENTANMELDUNG**

21 Anmeldenummer: 90107763.6

51 Int. Cl.⁵: G06F 15/70

22 Anmeldetag: 24.04.90

10 Priorität: 25.04.89 DE 3913620

43 Veröffentlichungstag der Anmeldung:
31.10.90 Patentblatt 90/44

84 Benannte Vertragsstaaten:
BE CH DE FR GB IT LI NL SE

71 Anmelder: **FRAUNHOFER-GESELLSCHAFT
ZUR FÖRDERUNG DER ANGEWANDTEN
FORSCHUNG E.V.**
Leonrodstrasse 54
D-8000 München 19(DE)

72 Erfinder: Korn, Axel, Dr.
Am Pfinztor 8
D-7500 Karlsruhe 41(DE)

54 Verfahren zur Bildauswertung.

57 Die Erfindung betrifft ein Verfahren zur Bildauswertung von Bildern einer Videokamera oder eines Fernsehbildes mittels einer Auswerteeinrichtung durch Analyse der Richtungen von Grauwertgradienten, wobei gespeicherte Bildmuster, z.B. Textilmuster oder Fahrzeuge, in dem auszuwertenden Bild ermittelt werden, wobei die Grauwertgradienten des Bildes normiert werden, das Histogramm der Gradientenrichtungen gebildet wird, indem die Häufigkeit der Gradientenwinkelwerte in Prozent gegen den Winkelwert, z.B. in einer Tabelle, festgelegt werden, die Kreuzkorrelation mit dem Histogramm des gespeicherten Bildmusters durchgeführt wird, der Winkelwert des Bildmusters um 1 oder einen beliebigen anderen Wert erhöht (modulo 360) und dieses neue Histogramm mit dem Bild kreuzkorreliert wird, diese Maßnahme 360 mal oder entsprechend weniger oft wiederholt wird und das Bild mit der höchsten Übereinstimmung der Kreuzkorrelation ermittelt wird.

EP 0 394 959 A2

Verfahren zur Bildauswertung

Die Erfindung bezieht sich auf ein Verfahren zur Bildauswertung nach dem Oberbegriff des Anspruch 1, wie er aus IEEE Transactions on PATTERN Analysis and machineintelligence PAMI-10 1988 p610-625 bekannt ist.

Auf dem Gebiet des "Maschinensehens" gibt es zahlreiche Verfahren zur Berechnung struktureller Merkmale wie Kanten, Ecken und Flächen aus Grauwertbildern, die z.B. über Produktionsregeln mit bekannten Testmustern verglichen werden können. Daneben gibt es statistische Verfahren, die sich insbesondere bei der Textur- und Schriftzeichenerkennung bewährt haben. Weit verbreitet ist die Korrelationsmethode für den Bildvergleich, wobei meistens eine zweidimensionale Korrelation der Grauwerte von zwei Bildern durchgeführt wird. Der Nachteil der geschilderten Methoden ist, daß entweder der Aufwand bei der Anwendung auf beliebige natürliche Bilder zu groß ist oder die oben geschilderten Invarianzeigenschaften nicht vorhanden sind.

Mittels des o.a. bekannten Verfahrens ist jedoch eine Analyse von Bildern nur beschränkt möglich, insbesondere sind einzelne zu erkennende Objekte im Bild, z.B. Texturunterscheidungen in Textilmustern, Fehler in bearbeiteten Oberflächen, fahrende Fahrzeuge in Videoaufzeichnungen, nicht zu ermitteln.

Aufgabe der Erfindung ist es, das bekannte Verfahren dahingehend zu verbessern, daß Testmuster in auszuwertenden Bildern erkannt werden, wobei die Umgebung der Testmuster zu keiner Verschlechterung der Ergebnisse führen soll.

Diese Aufgabe wird durch das Verfahren nach Anspruch 1 gelöst, vorteilhafte Ausgestaltungen sind in den Unteransprüchen gekennzeichnet.

Das erfindungsgemäße Verfahren baut auf dem o.a. Verfahren auf; dabei werden Bilddaten durch Anwendung eines speziellen Gradientenoperators auf beliebige Grauwertbilder erzeugt. Man erhält ein Bild, in welchem für jeden Bildpunkt der Betrag und die Richtung des Grauwertgradienten mit jeweils 8 bit Auflösung vorliegen. Die Gradientenrichtung ist invariant gegenüber Addition und Multiplikation der Bildfunktion mit Konstanten. Kontrastumkehr bedeutet Addition von 180 Grad zu jedem Richtungswert.

Für den Bildvergleich wird zunächst das Histogramm der Gradientenrichtungen in einem interessierenden Bildfenster gebildet, wobei auf die Gesamtzahl der verwendeten Bildpunkte in diesem Fenster normiert wird. Man erhält eine eindimensionale Funktion: Häufigkeit von Winkelwerten in Prozent vs. Winkelwert. Zur Reduktion von Rauschen wird das Histogramm durch Faltung mit einer eindimensionalen Gaußfunktion geglättet. Die Standardabweichung wird interaktiv eingelesen.

Danach wird der Vergleich mit anderen Bildfenstern durch Kreuzkorrelation der eindimensionalen Histogramme durchgeführt. Nach jeder Korrelation werden die Winkelwerte auf der Abzisse des Referenzhistogramms jeweils um $1 = 2^\circ$ (oder einen beliebigen Wert modulo 360) erhöht und mit diesem Histogramm erneut eine Kreuzkorrelation durchgeführt und das 180 mal. Mit Hilfe dieses wichtigen Schrittes werden mögliche Drehungen des Vergleichs - gegen das Referenzmuster quantitativ erfaßt durch Bestimmung des maximalen Kreuzkorrelationskoeffizienten in Abhängigkeit vom Drehwinkel. Hierdurch wird auch Invarianz gegenüber Kontrastumkehr erreicht (s.o.). Durch Normierung auf die Gesamtzahl der berücksichtigten Bildpunkte - die Häufigkeit bestimmten Richtungen wird in Prozent angegeben - wird eine Größeninvarianz erreicht.

Bei der Suche in Bildern durch einstellbare Verschiebung von Bildfenstern, deren Histogramme mit der Referenz korreliert werden, wird für jede Fensterposition der Kreuzkorrelationskoeffizient berechnet. Anschließend wird vorzugsweise das Bildfenster mit dem größten Zahlenwert (oberhalb einer einstellbaren Schwelle) ausgewertet oder auch benachbarte mit ähnlichen Werten.

Das geschilderte Verfahren hat folgende Vorteile gegenüber bestehenden technischen Verfahren:

1. Es werden nicht zweidimensionale, sondern eindimensionale Funktionen (Histogramme) korreliert, die sich leicht berechnen lassen und deren Wertebereich unabhängig von der Größe der verwendeten Bilder ist. Dadurch ergibt sich eine erhebliche Aufwandsreduktion, welche technische Anwendungen in Echtzeit mit Hilfe heute verfügbarer elektronischer Bausteine ermöglicht.

2. Dadurch, daß nicht (wie beim Bildvergleich üblich) Grauwerte sondern die geglätteten Häufigkeiten von Winkelwerten korreliert werden, ergeben sich Invarianzen gegenüber Drehungen, Größen- und Kontraständerungen. Dadurch erhält man ein robustes Detektionsverfahren, bei welchem auch der Einfluß der Umgebung der zu detektierenden Objekte bisher zu keiner nennenswerten Verschlechterung der Ergebnisse geführt hat.

Im folgenden wird das bekannte Verfahren zum besseren Verständnis der Erfindung anhand der Abb. 1 erläutert. Die Erfindung wird dann anhand der Abb. 2 dargestellt.

In der o.a. Literaturstelle wird ausführlich auf die Problematik der Beschreibung von Grauwertänderun-

gen mit Hilfe von Gradientenfiltern variabler Größe eingegangen. Es wurde eine Filterbank vorgeschlagen, in welcher über ein Auswahlkriterium automatisch die jeweils beste Maskengröße bestimmt werden kann. Aus Aufwandsgründen sollte man sich jedoch auf wenige Maskengrößen beschränken, welche mit Hilfe von a priori Wissen bez. der zu bearbeitenden Szene festgelegt werden können. Der Grundgedanke für das im folgenden beschriebene Verfahren besteht darin, durch eine relativ große Filtermaske Bildrauschen und Texturen soweit zu eliminieren, daß zusammenhängende Flächen mit möglichst homogenen Gradientenrichtungen entstehen. Diese Flächen sollten wesentlich grösser sein als der verwendete Faltungskern. Örtlich sich langsam ändernde Grauwertverläufe werden aufgrund ihrer niedrigen Ortsfrequenz kaum beeinflusst und lassen sich in dem bandpaßgefilterten Bild relativ einfach durch die einheitliche Gradienteneinrichtung innerhalb des ansteigenden bzw. abfallenden Bereiches der Grauwertfläche detektieren. Schatten und Schattierungen führen zu einem signifikanten Maximum im Histogramm der Gradientenrichtungen. Dieses Maximum kann in Verbindung mit einem gewissen Toleranzbereich dazu benutzt werden, zusammenhängende Flächen im Bildbereich zu gewinnen und als mögliche Schatten- oder Schattierungsbereiche zu charakterisieren.

Zur Gradientenberechnung bei den in Abb. 1 gezeigten Beispielen wurden 11×13 Masken verwendet, das entspricht einer Standardabweichung von $\sigma = 2.0$ für das Gradientenfilter (normierte Ableitung einer Gaußfunktion).

Bei dieser Maskengröße wird das Digitalisierungsrauschen stark vermindert. Die Maske dient zusätzlich zur Reduktion störender Texturen innerhalb von Schatten-/Schattierungsbereichen, wobei die Größe der Abschwächung von den betreffenden Ortsfrequenzen abhängt.

Den weiteren Überlegungen wird die Häufigkeitsverteilung von Winkelwerten in verschiedenen Bildfeldstern zugrundegelegt, deren Größe und Position einstellbar ist. Für Schatten und Schattierungen wird eine Vorzugsrichtung der Gradientenrichtung in einem Bildbereich erwartet, der deutlich größer als der Faltungskern sein sollte.

Für das Beispiel des PKW in Abb. 1a veranschaulichen Abb. 1b und c) die beschriebene Vorgehensweise. In b) sind die helligkeitskodierte Gradientenrichtungen (siehe Beschreibung weiter unten) dargestellt. Die Konvention für den Gradientenwinkel geht aus Abb. 1d hervor. Die Gradientenrichtung ist so festgelegt, daß der Vektor stets von dunkel nach hell zeigt, wobei der Winkel im Uhrzeigersinn zunimmt.

In Abb. 1c ist zusätzlich die Maßnahme b) des Anspruchs 1 bildlich dargestellt.

Die Auswertung des Histogramms für den markierten Bildausschnitt in b) ergibt, daß 95 % der Bildpunkte Winkelwerte im Bereich 88 ± 16 Grad haben. Diese Winkelwerte sind in c) weiß dargestellt. Als größter zusammenhängender Bereich ergibt sich der Schatten vor dem PKW. Wie aufgrund der Beleuchtungsbedingungen zu erwarten war, ergeben sich zusätzliche Bereiche, z.B. auf der Kühleroberfläche, welche Hinweise auf das Vorhandensein langsam veränderlicher Grauwertänderungen liefern.

Im Unterschied zu der bekannten Vorgehensweise werden erfindungsgemäß nicht signifikante Maxima des Winkelhistogramms ausgewertet, sondern das vollständige Histogramm der Gradientenrichtungen eines vorgegebenen Grauwertmusters als Modell oder Referenzmuster verwendet. Die größte Ähnlichkeit mit einem solchen Referenzmuster wird durch eine Kreuzkorrelation mit den Winkelhistogrammen anderer Grauwertmuster (Vergleichsmuster in einem Suchbild) ermittelt. Zunächst wird das Histogramm der Gradientenrichtungen in einem interessierenden Bildbereich berechnet. Man erhält eine eindimensionale Funktion: Häufigkeit von Winkelwerten vs. Winkel (Grad). Zur Rauschverminderung wird das Histogramm durch Faltung mit einer eindimensionalen Gaußfunktion, deren Breite einstellbar ist, geglättet. In Abb. 2b ist ein solches geglättetes Histogramm für die Gradientenrichtungen ($\sigma = 1.0$) des Kastenwagens in a) dargestellt. Die Glättung erfolgte mit einer 1×9 Maske ($\sigma = 2.0$). Die vier Maxima des Histogramms bei 92, 180, 270 und 360 Grad repräsentieren die vertikal und horizontal orientierten Vorzugsrichtungen des Fahrzeugs.

Drehungen des Vergleichs gegenüber dem Referenzmuster lassen sich sehr einfach dadurch berücksichtigen, daß nach jeder Korrelation die Winkelwerte auf der Abzisse eines der beiden zu korrelierenden Histogramme jeweils um 1 oder einen beliebigen anderen Wert modulo 360 Grad erhöht werden und mit diesem Histogramm erneut eine Kreuzkorrelation durchgeführt wird. Mit Hilfe dieses Schrittes werden mögliche Drehungen der o.g. Muster quantitativ erfaßt durch Bestimmung des maximalen Wertes des Kreuzkorrelationskoeffizienten in Abhängigkeit von der oben durchgeführten Translation, welche dem Drehwinkel entspricht.

Zur Verdeutlichung der beschriebenen Vorgehensweise soll das folgende Beispiel dienen. Abb. 2a ist ein Ausschnitt aus dem 1. Bild einer Bildserie, in welcher sich der Kastenwagen weg von der Kamera bewegt. Das geglättete Histogramm der Gradientenrichtungen von a) ist in Abb. 2b dargestellt. Dieses Histogramm wurde als Referenzmuster verwendet, um das Fahrzeug im 300. Bild dieser Bildfolge automatisch zu lokalisieren. Trotz einer Größenänderung von 3:1 des Fahrzeugs und einer (künstlich) durchgeführ-

ten Drehung von 45 Grad, befindet sich der Kastenwagen weitgehend innerhalb des Fensters mit dem größten Kreuzkorrelationskoeffizienten $r = 0.869$. Die Mitte dieses 90 Spalten und 150 Zeilen großen Vergleichsmusters ist in Abb. 2c durch ein weißes Rechteck markiert. Zusätzlich erhält man das Ergebnis, daß der höchste Kreuzkorrelationskoeffizient mit dem um 46 Grad verschobenen Referenzhistogramm erzielt wurde. Die übrigen Rechtecke markieren die Mitten weiterer Vergleichsmuster in diesem 343 Spalten x 256 Zeilen großen Suchbild, in welchem mit einer Schrittweite von 70 Spalten und 80 Zeilen ein 90 x 150 Bildfenster zur Erzeugung von 8 (sich überlappenden) Vergleichsmustern automatisch verschoben wurde. Der Kreuzkorrelationskoeffizient r wird nach folgender bekannten Vorschrift ermittelt, wobei sich die x -Werte auf die Daten des Referenzmusters und die y -Werte auf die Daten des Vergleichsmusters beziehen:

$$r = \frac{\sum_i (x(i) - \bar{x}) \cdot (y(i) - \bar{y})}{\sqrt{\sum_i (x(i) - \bar{x})^2 \sum_i (y(i) - \bar{y})^2}} \quad ; \bar{x}, \bar{y}: \text{Mittelwerte}$$

Ansprüche

1. Verfahren zur Bildauswertung von Bildern einer Videokamera oder eines Fernsehbildes mittels einer Auswerteinrichtung durch Analyse der Richtungen von Grauwertgradienten, wobei gespeicherte Bildmuster, z.B. Textilmuster oder Fahrzeuge, in dem auszuwertenden Bild ermittelt werden und die Grauwertgradienten des Bildes normiert werden, **dadurch gekennzeichnet**, daß
 - a) das Histogramm der Gradientenrichtungen gebildet wird, indem die Häufigkeit der Gradientenwinkelwerte in Prozent gegen den Winkelwert, z.B. in einer Tabelle, festgelegt werden,
 - b) die Kreuzkorrelation mit dem Histogramm des gespeicherten Bildmusters durchgeführt wird,
 - c) der Winkelwert des Bildmusters um 1 oder einen beliebigen anderen Wert erhöht (modulo 360) und dieses neue Histogramm mit dem Bild kreuzkorreliert wird,
 - d) Maßnahme d 360 mal oder entsprechend weniger oft wiederholt wird,
 - e) das Bild mit der höchsten Übereinstimmung der Kreuzkorrelation ermittelt wird.
2. Verfahren nach Anspruch 1, **dadurch gekennzeichnet**, daß das Histogramm durch Faltung mit einer Gaußfunktion geglättet wird.
3. Verfahren nach Anspruch 2, **dadurch gekennzeichnet**, daß Faltungskerne von 5 x 7 oder 11 x 13 Elemente verwendet werden.
4. Verfahren nach Anspruch 1, **dadurch gekennzeichnet**, daß zusätzlich das Histogramm des Betrages des Grauwertgradienten und/oder des Grauwertes gebildet und die Kreuzkorrelation durchgeführt wird.

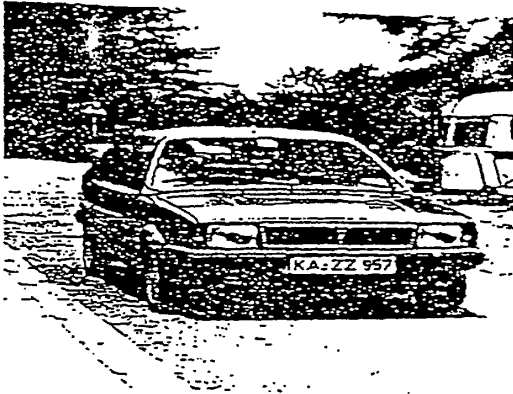

a) Original

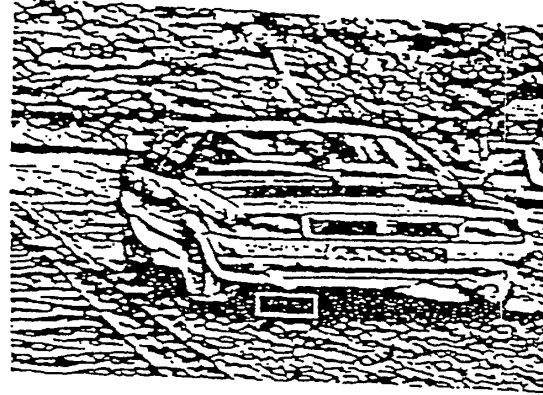

b) Gradientenrichtung ($\sigma=2.0$)



c) Weiß: 88 ± 16 Grad Bereiche

Winkelkonvention

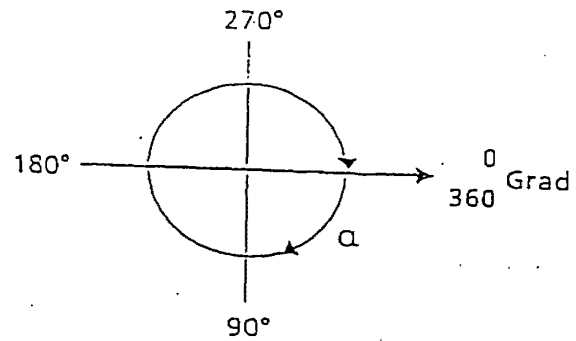

d) Dem 360 Grad Winkelbereich werden 180 Grauwerte zugeordnet

Abb. 1

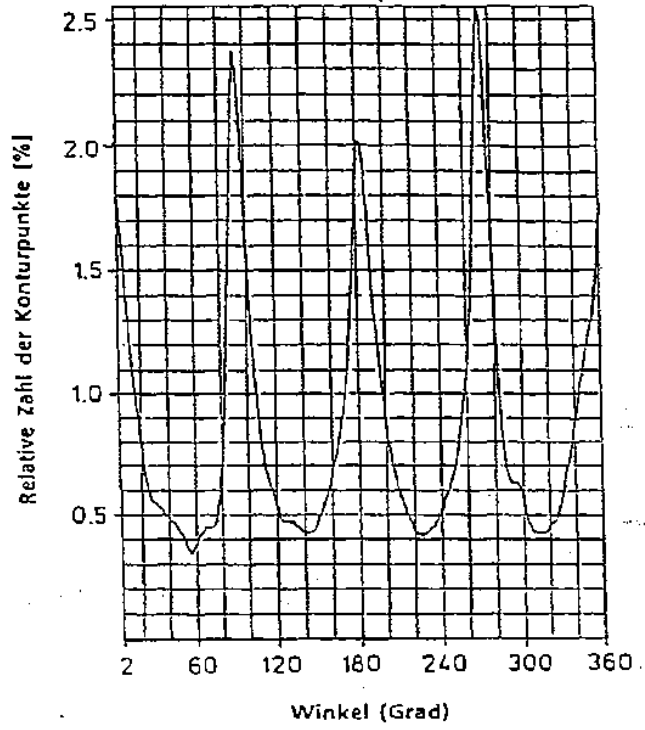
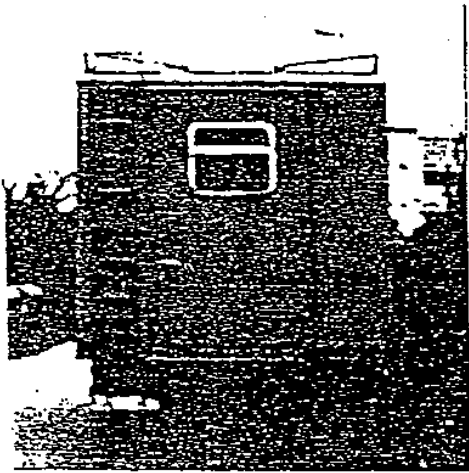

a) Grauwerte des Referenzbildes

b) Winkelhistogramm von a)

Abb. 2



c) Weißes Quadrat:
max. Korrelation



EUROPÄISCHE PATENTANMELDUNG

Anmeldenummer: 90107763.6

Int. Cl.⁵: **G06F 15/70**

Anmeldetag: 24.04.90

Priorität: 25.04.89 DE 3913620

Anmelder: **FRAUNHOFER-GESELLSCHAFT
ZUR FÖRDERUNG DER ANGEWANDTEN
FORSCHUNG E.V.**
Leonrodstrasse 54
W-8000 München 19(DE)

Veröffentlichungstag der Anmeldung:
31.10.90 Patentblatt 90/44

Benannte Vertragsstaaten:
BE CH DE FR GB IT LI NL SE

Erfinder: Korn, Axel, Dr.
Am Pflinztor 8
W-7500 Karlsruhe 41(DE)

Veröffentlichungstag des später veröffentlichten
Recherchenberichts: 03.02.93 Patentblatt 93/05

Verfahren zur Bildauswertung.

Die Erfindung betrifft ein Verfahren zur Bildauswertung von Bildern einer Videokamera oder eines Fernsehbildes mittels einer Auswerteinrichtung durch Analyse der Richtungen von Grauwertgradienten, wobei gespeicherte Bildmuster, z.B. Textilmuster oder Fahrzeuge, in dem auszuwertenden Bild ermittelt werden, wobei die Grauwertgradienten des Bildes normiert werden, das Histogramm der Gradientenrichtungen gebildet wird, indem die Häufigkeit der Gradientenwinkelwerte in Prozent gegen den Winkelwert, z.B. in einer Tabelle, festgelegt werden, die Kreuzkorrelation mit dem Histogramm des gespeicherten Bildmusters durchgeführt wird, der Winkelwert des Bildmusters um 1 oder einen beliebigen anderen Wert erhöht (modulo 360) und dieses neue Histogramm mit dem Bild kreuzkorreliert wird, diese Maßnahme 360 mal oder entsprechend weniger oft wiederholt wird und das Bild mit der höchsten Übereinstimmung der Kreuzkorrelation ermittelt wird.

EP 0 394 959 A3



Europäisches
Patentamt

EUROPÄISCHER RECHERCHENBERICHT

Nummer der Anmeldung

EP 90 10 7763

EINSCHLÄGIGE DOKUMENTE			
Kategorie	Kennzeichnung des Dokuments mit Angabe, soweit erforderlich, der maßgeblichen Teile	Betrifft Anspruch	KLASSIFIKATION DER ANMELDUNG (Int. Cl.5)
A	WO-A-8 706 376 (VARTEC CORPORATION) * Seite 35, Zeile 3 - Zeile 17 * * Seite 40, Zeile 7 - Zeile 15 * -----	1	G06F15/70
A	PATENT ABSTRACTS OF JAPAN vol. 10, no. 52 (P-432)28. Februar 1986 & JP-A-60 195 685 (FUJITSU KK) 4. Oktober 1985 * Zusammenfassung * -----	1	
			RECHERCHIERTE SACHGEBIETE (Int. Cl.5)
			G06F G06K
Der vorliegende Recherchenbericht wurde für alle Patentansprüche erstellt			
Recherchenamt DEN HAAG		Abschließdatum der Recherche 07 DEZEMBER 1992	Prüfer CHATEAU J.P.
KATEGORIE DER GENANNTEN DOKUMENTE			
X : von besonderer Bedeutung allein betrachtet Y : von besonderer Bedeutung in Verbindung mit einer anderen Veröffentlichung derselben Kategorie A : technologischer Hintergrund O : mündliche Offenbarung P : Zwischenliteratur		T : der Erfindung zugrunde liegende Theorien oder Grundsätze E : älteres Patentdokument, das jedoch erst am oder nach dem Anmeldedatum veröffentlicht worden ist D : in der Anmeldung angeführtes Dokument L : aus andern Gründen angeführtes Dokument A : Mitglied der gleichen Patentfamilie, übereinstimmendes Dokument	

EPO FORM 150 (03.82 (P/04))

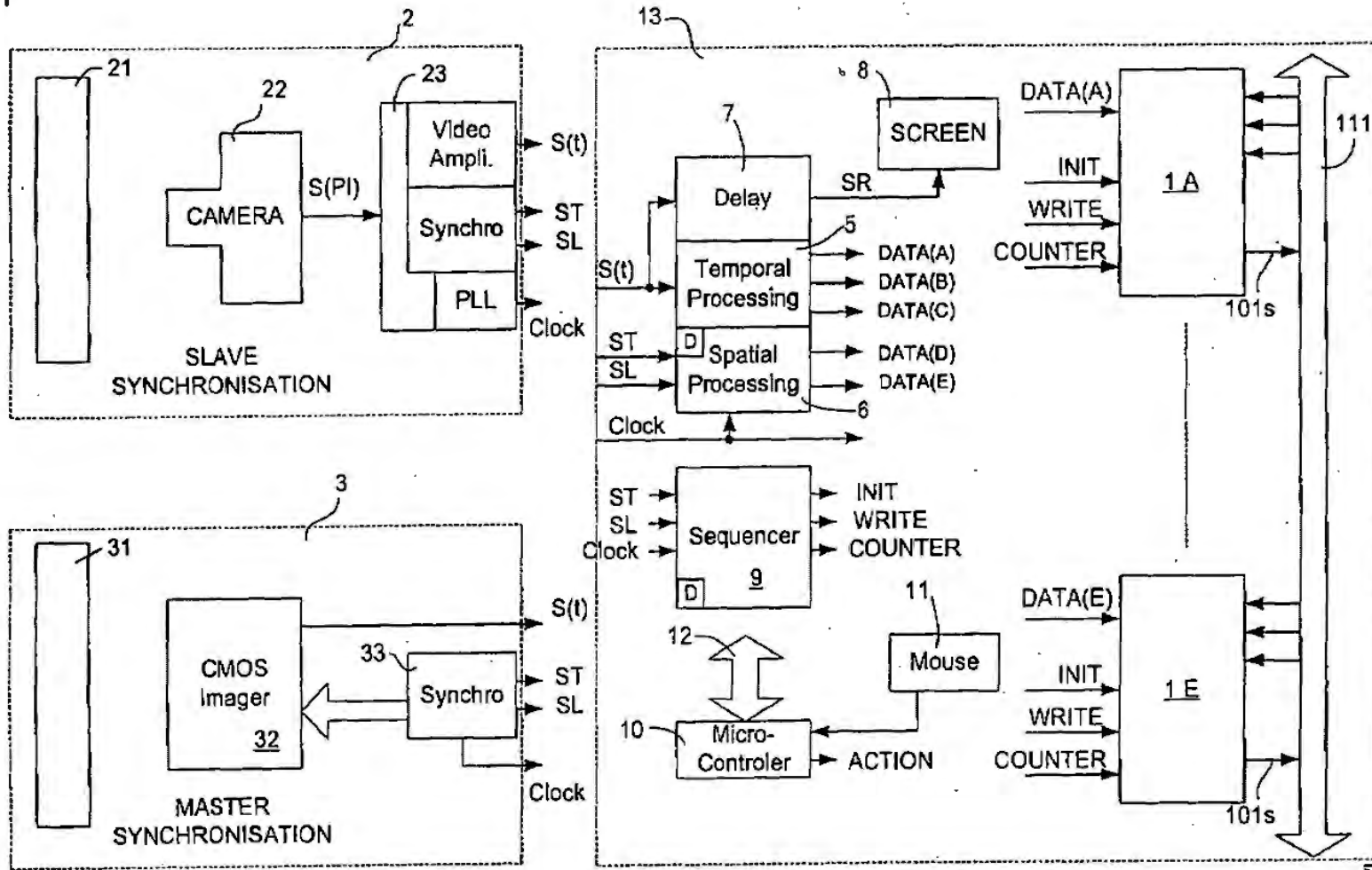

FIG. 1 PRIOR ART

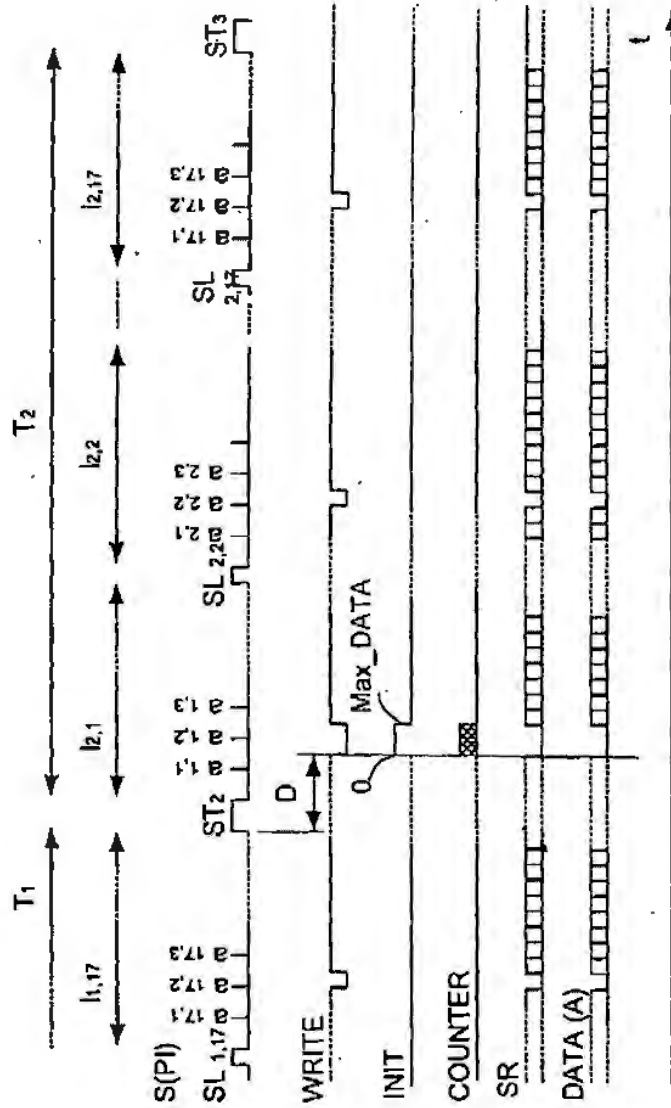

FIG. 2

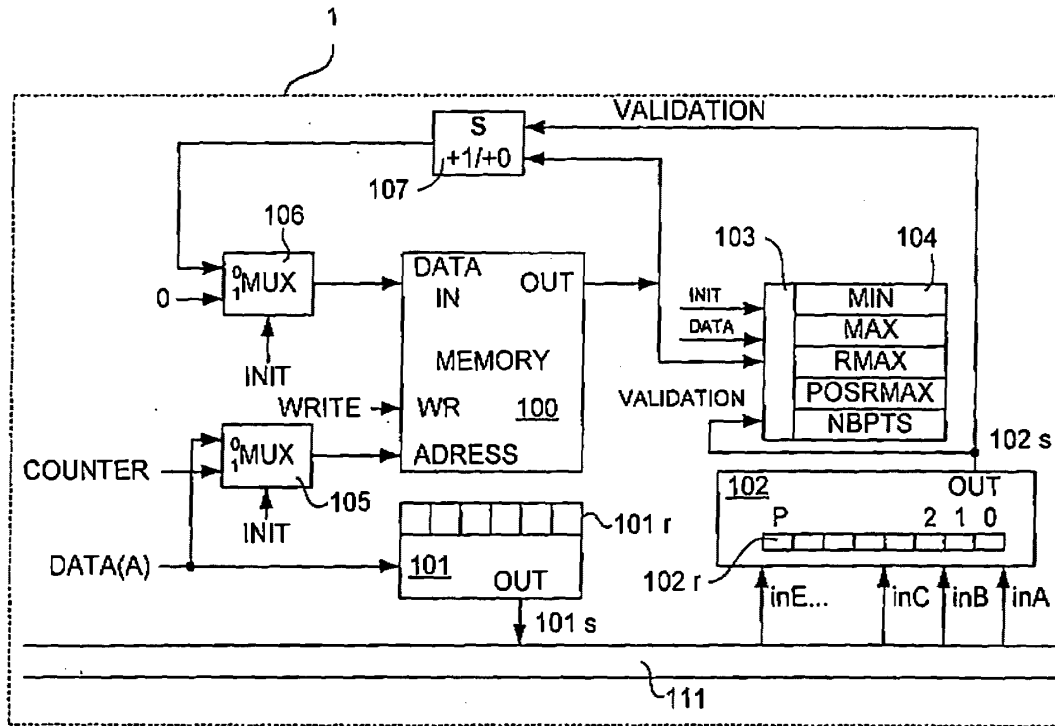

FIG. 3

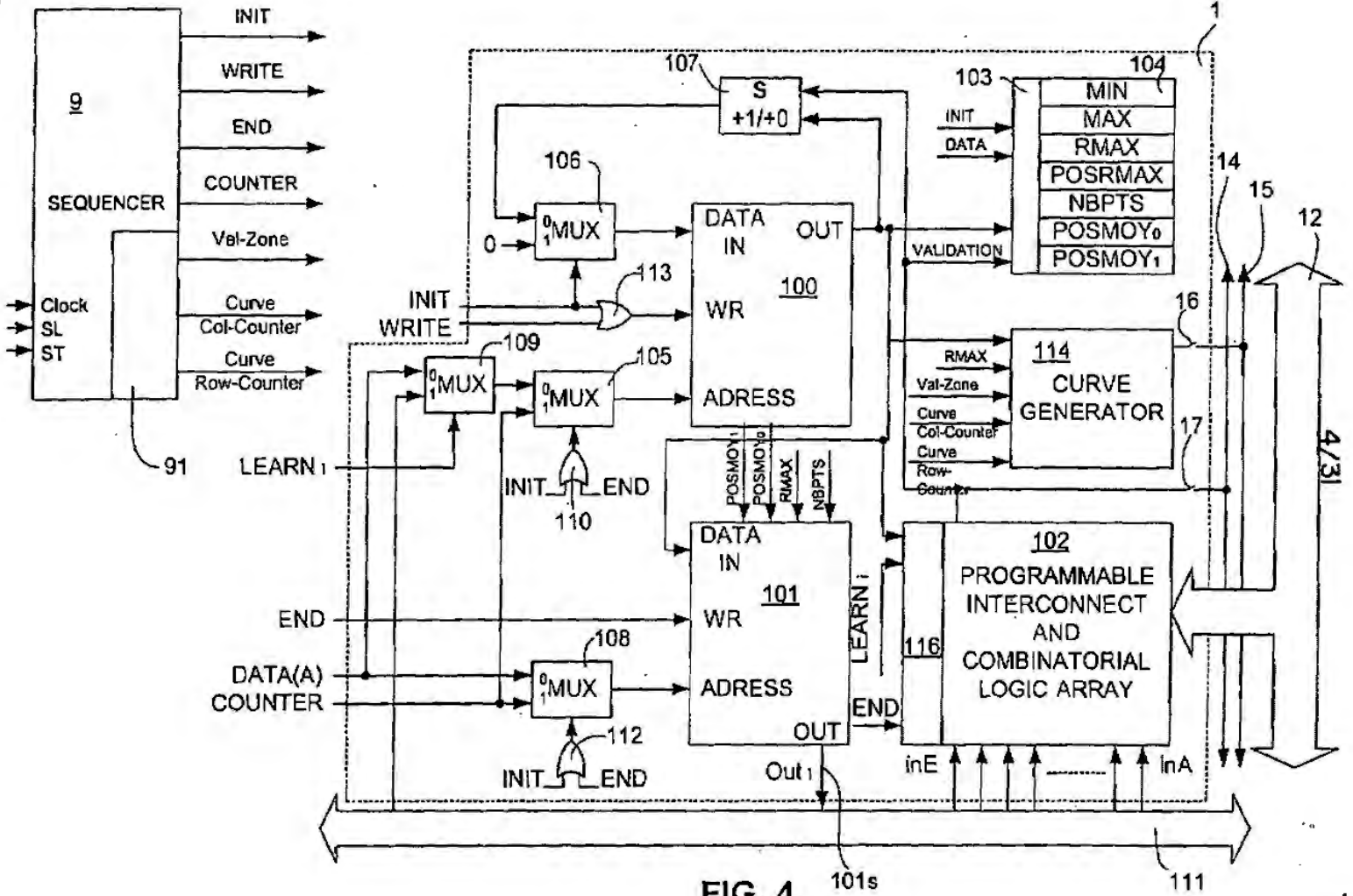

FIG. 4

5/31

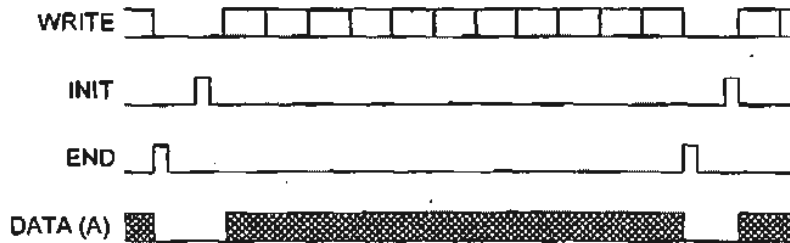

FIG. 5

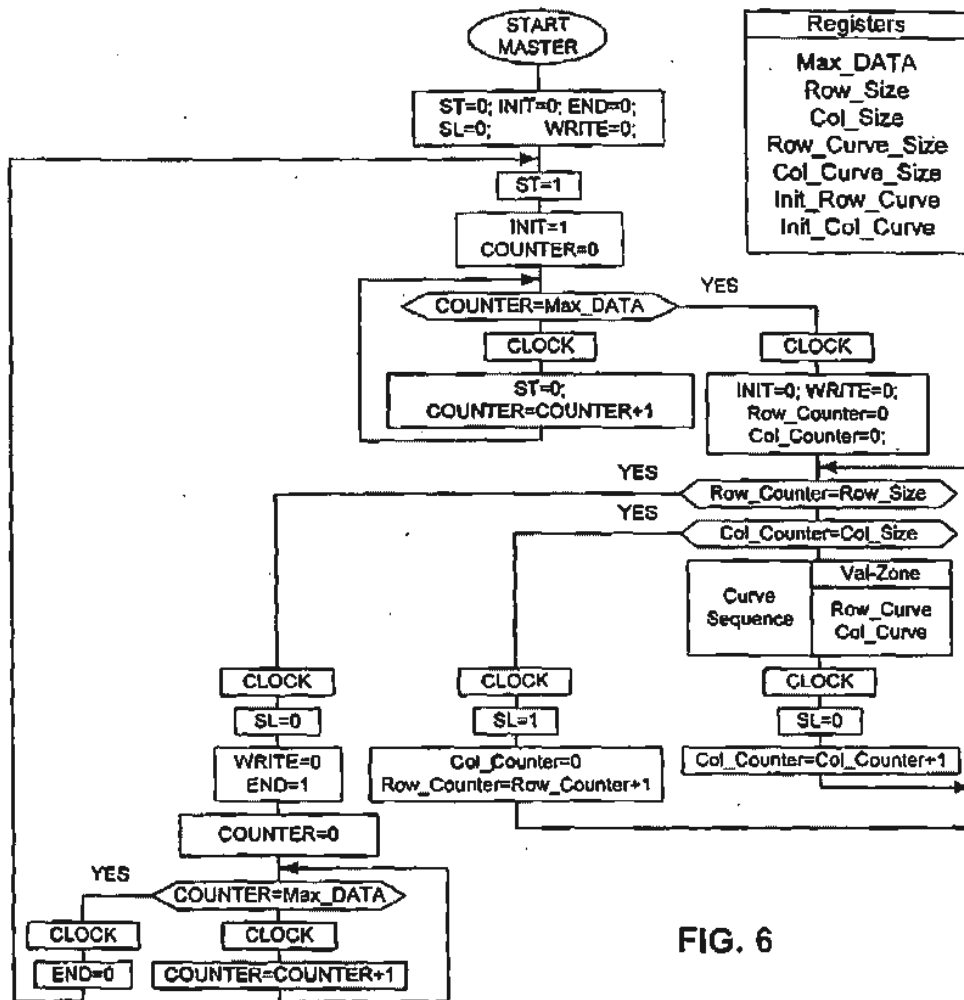

FIG. 6

6/31

+

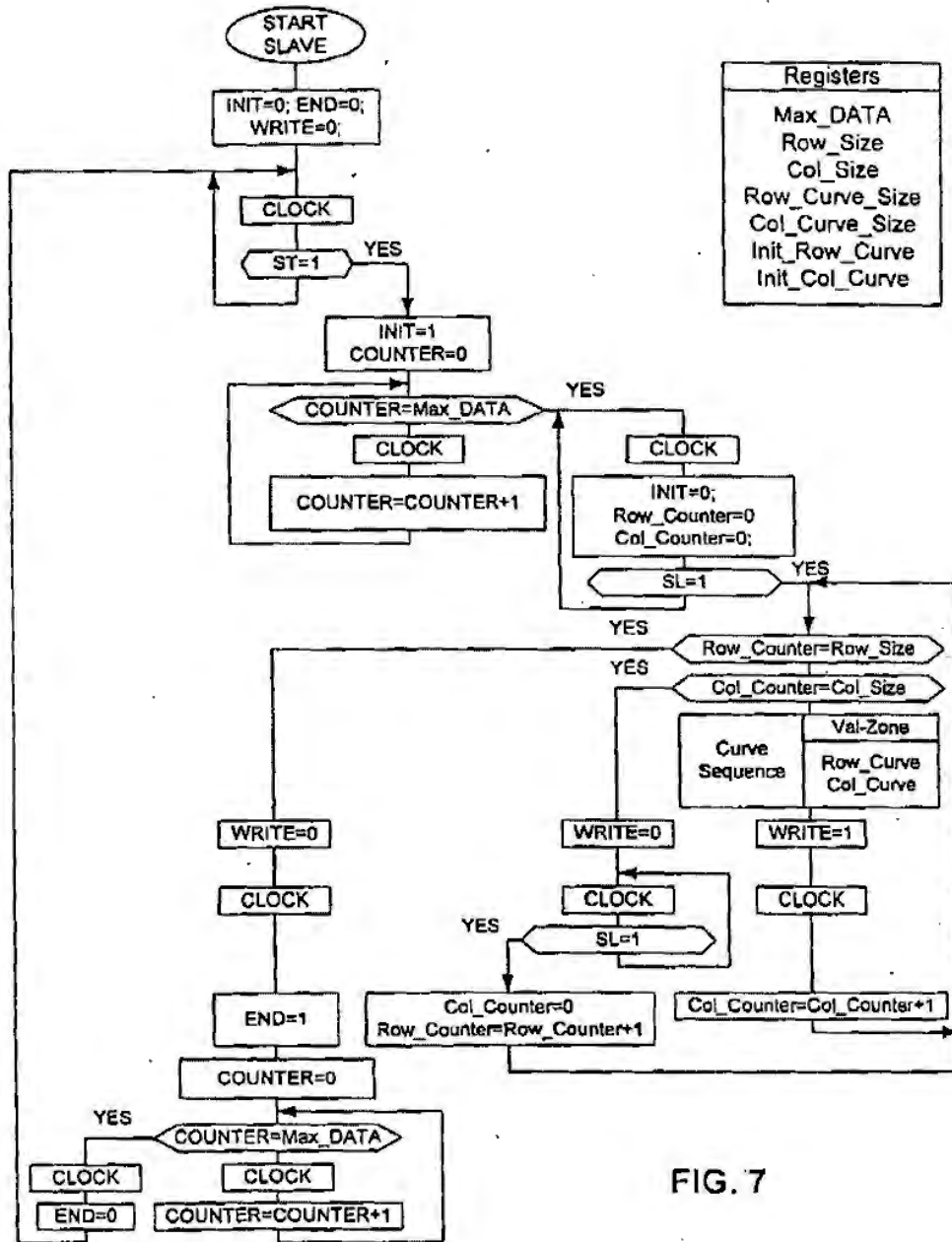
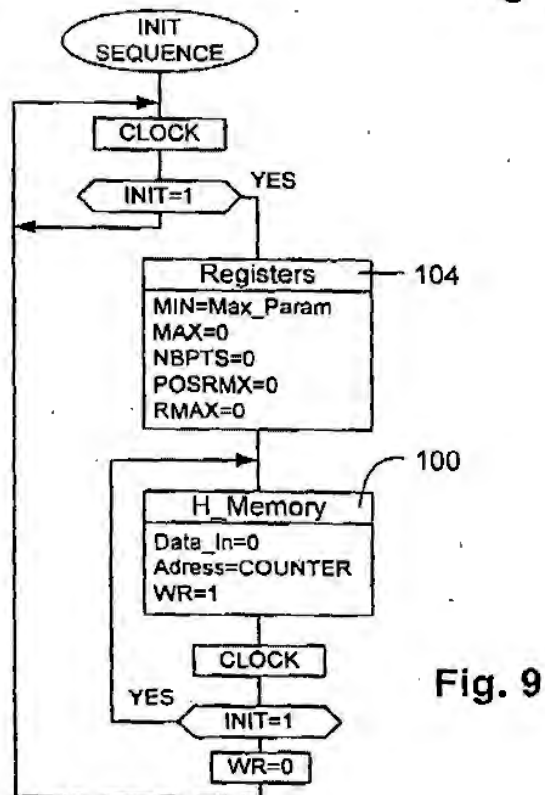
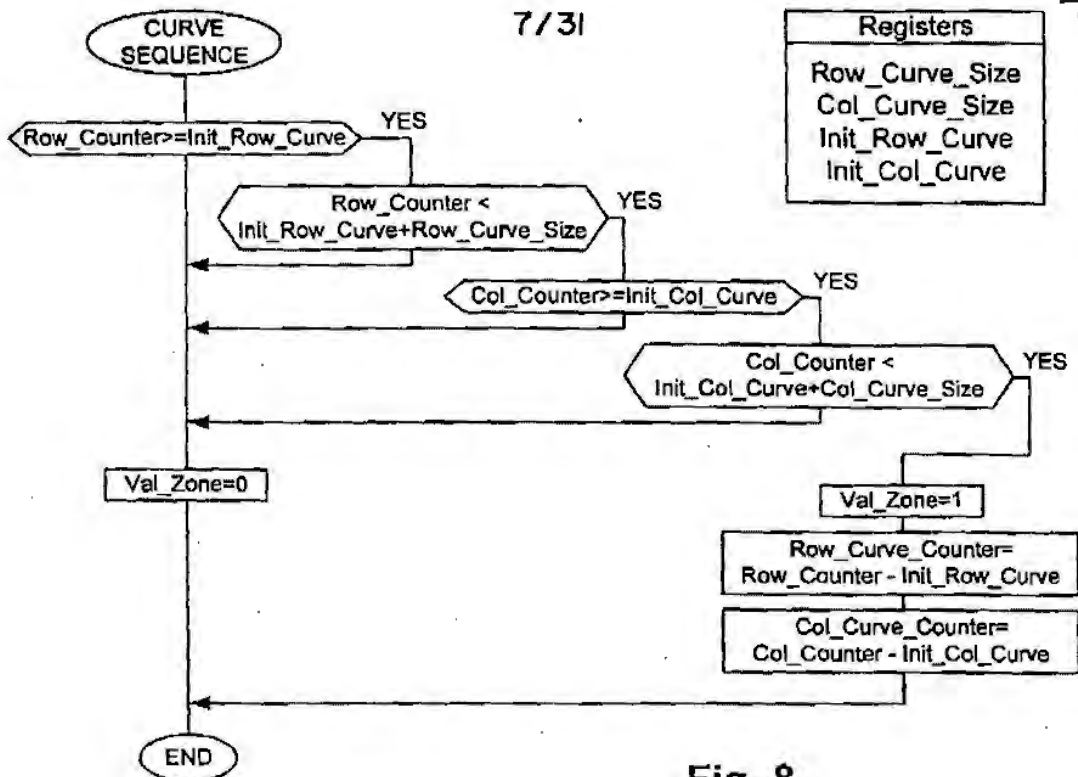

FIG. 7



8/31

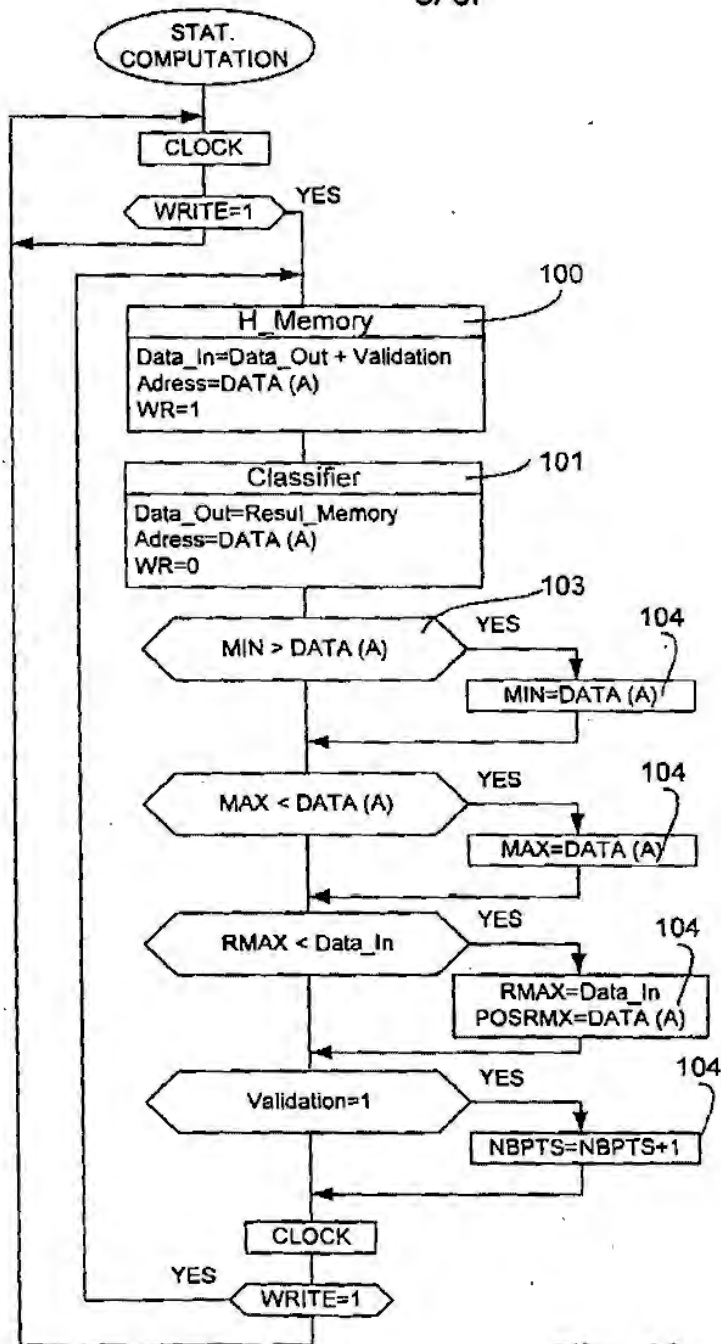

Fig. 10

9/31

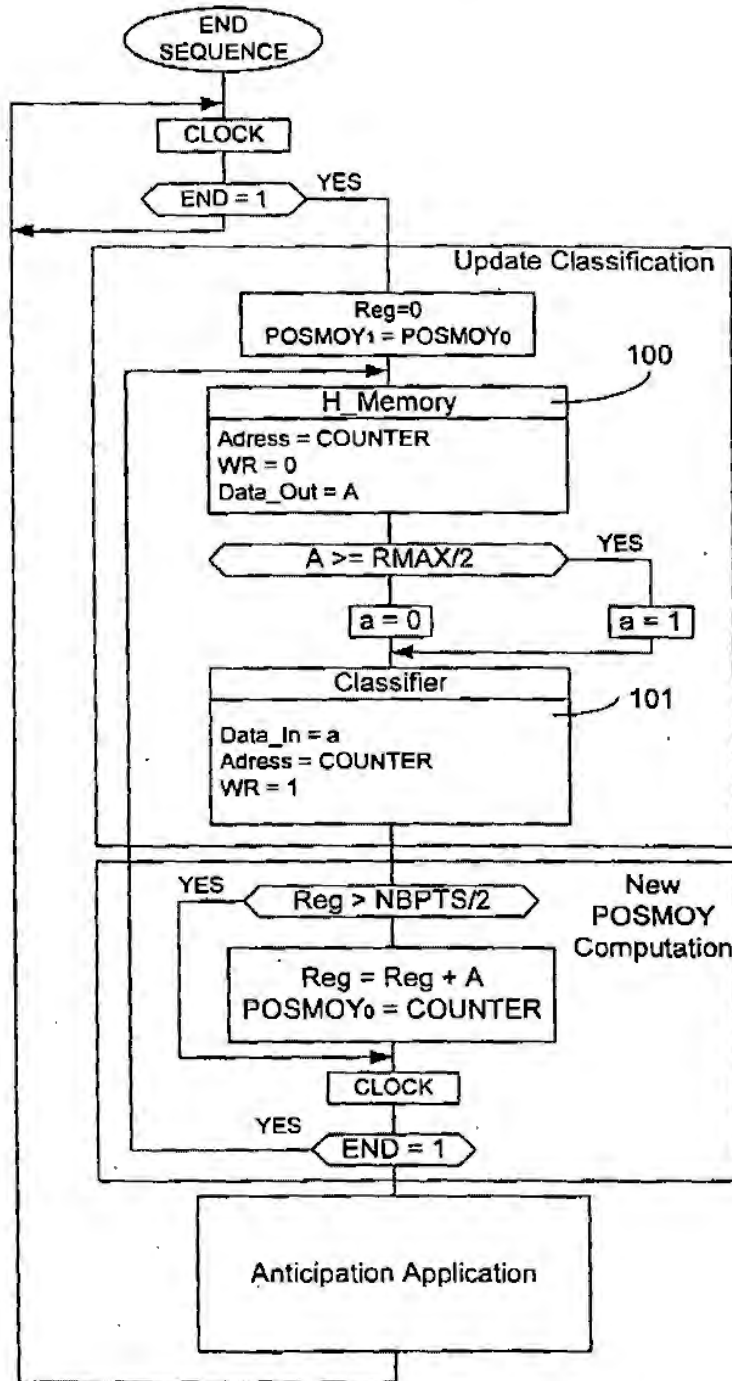

Fig. 11

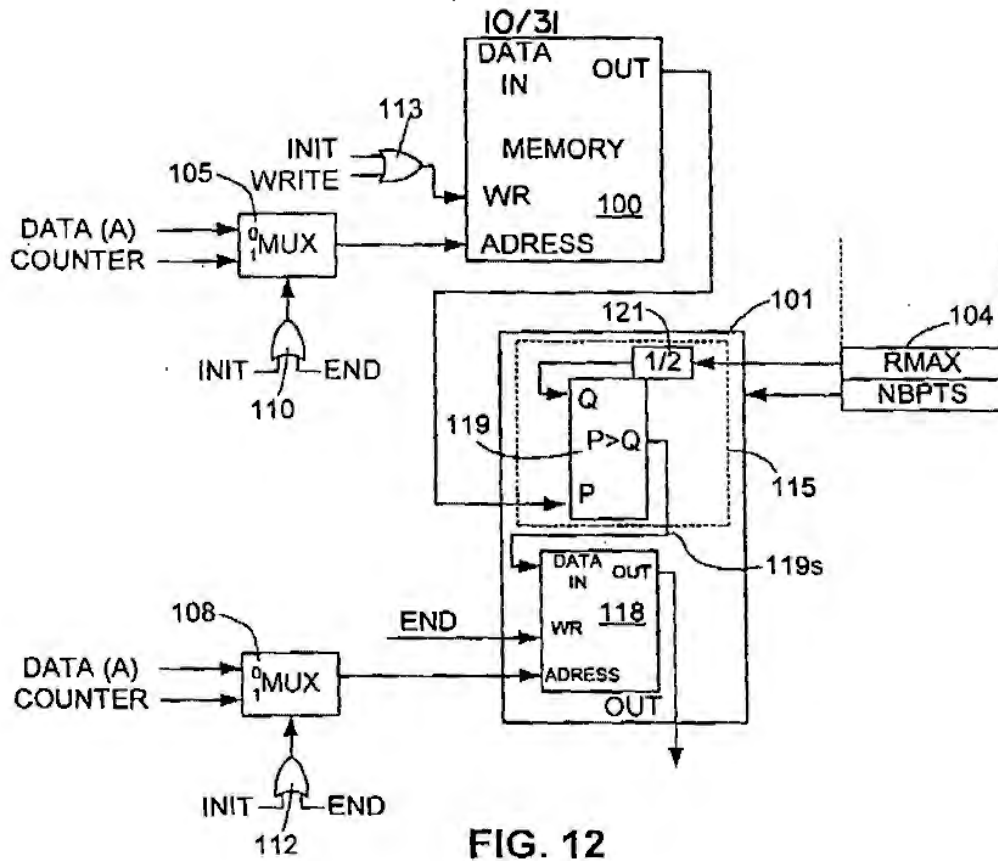

FIG. 12

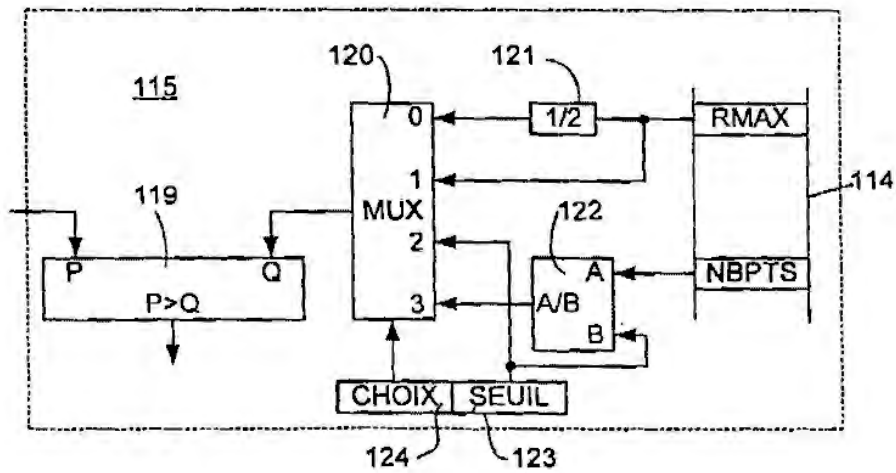

FIG. 13

11/31

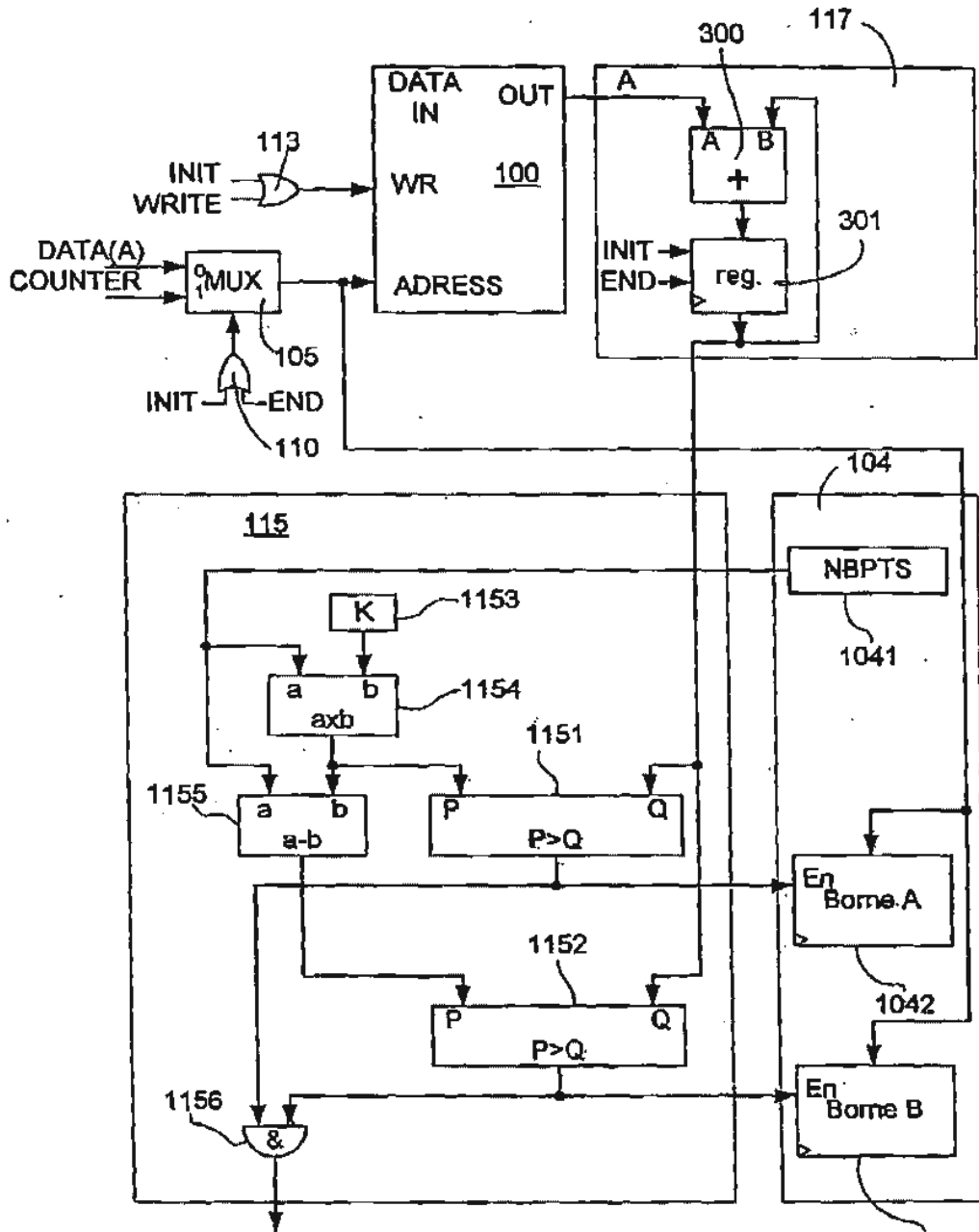

FIG. 13c

12/31

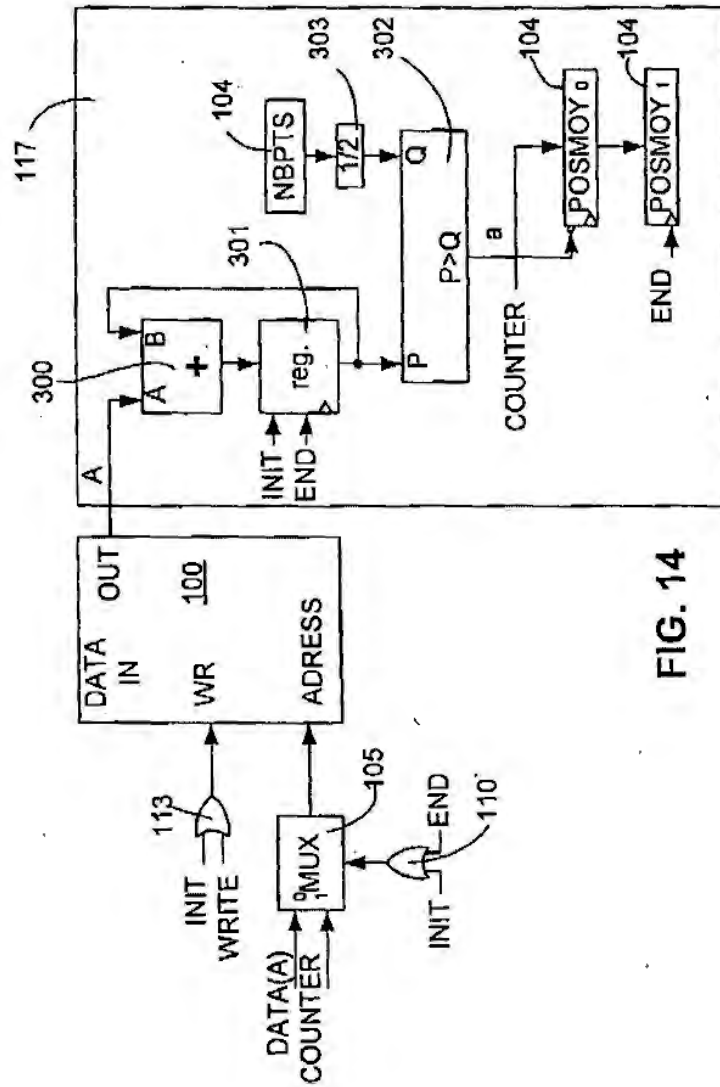

FIG. 14

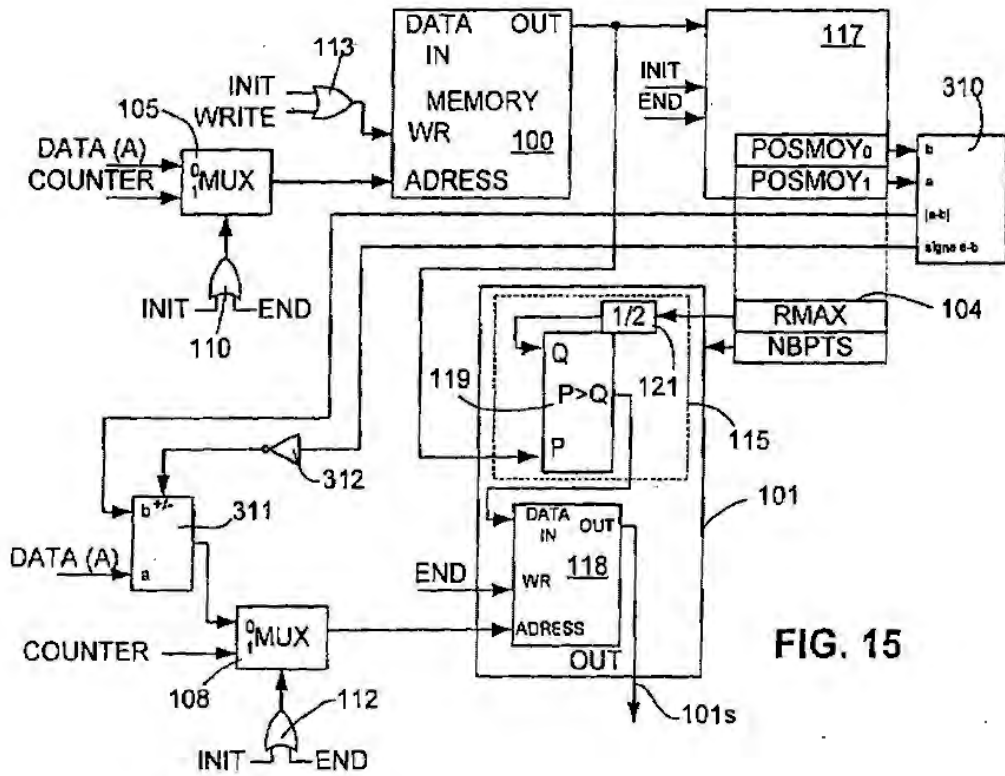

FIG. 15

13/31

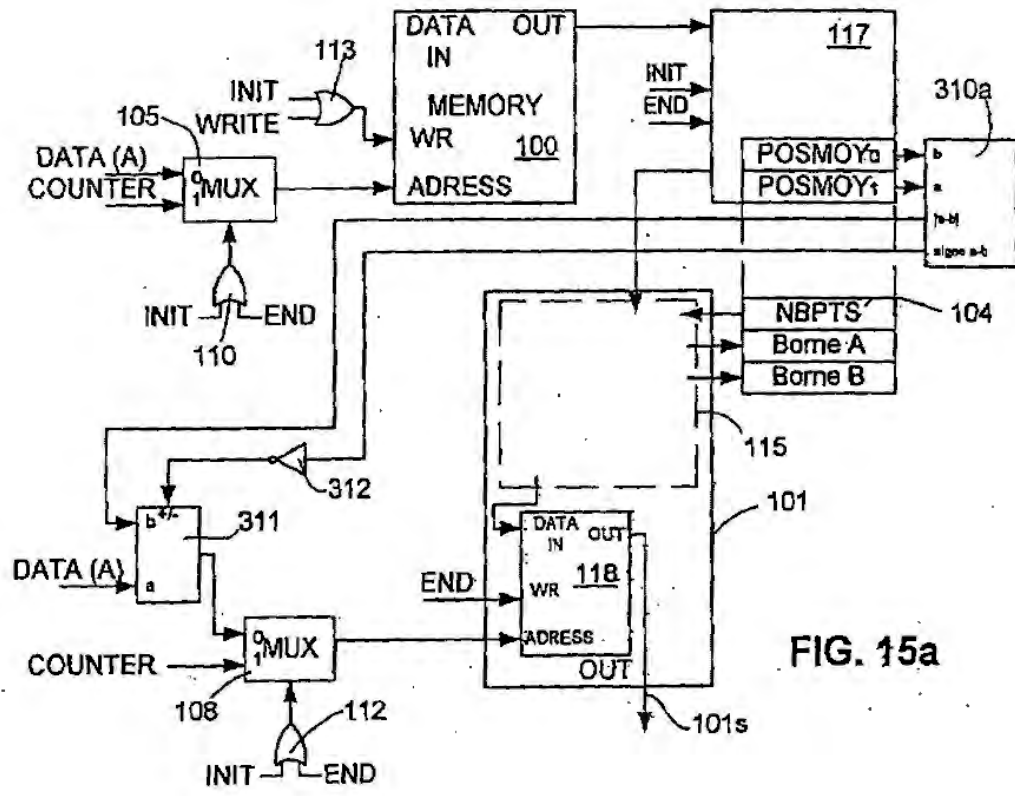

FIG. 15a

14/31

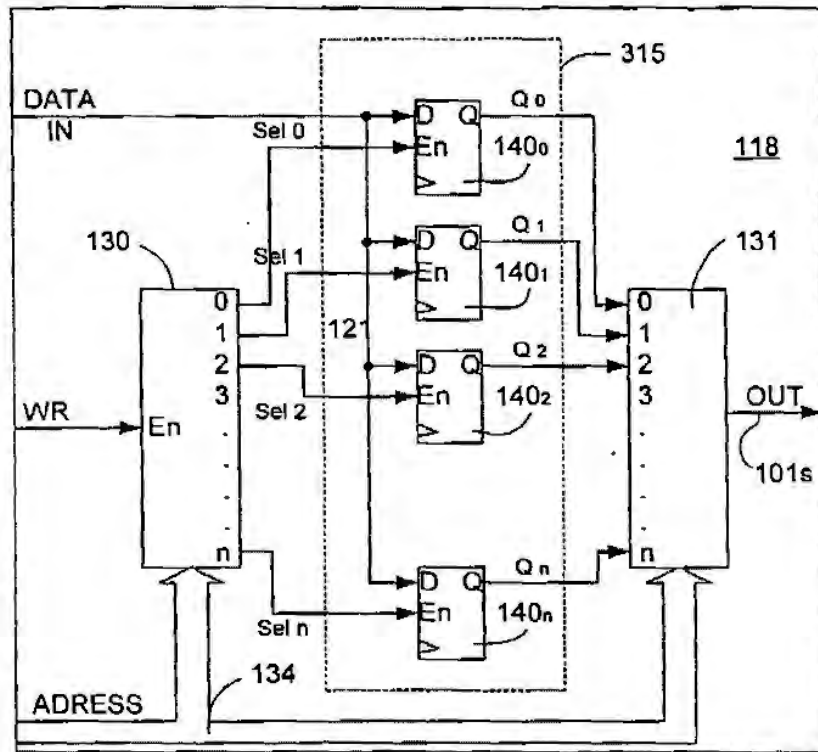

FIG. 16



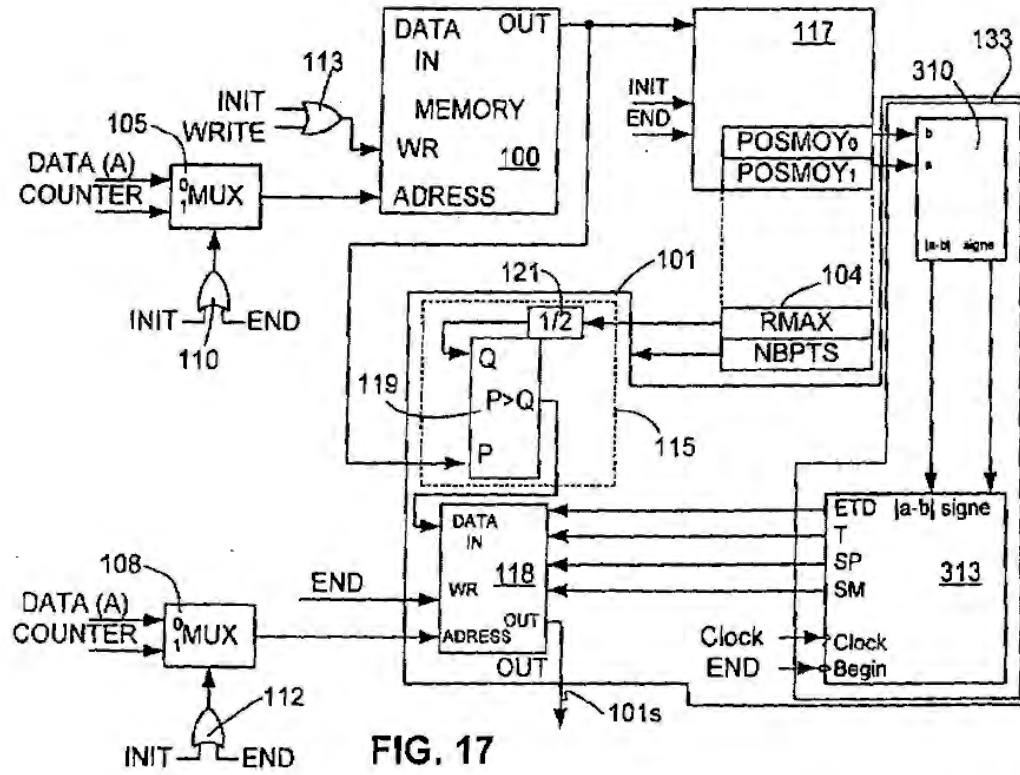

FIG. 17

16/31

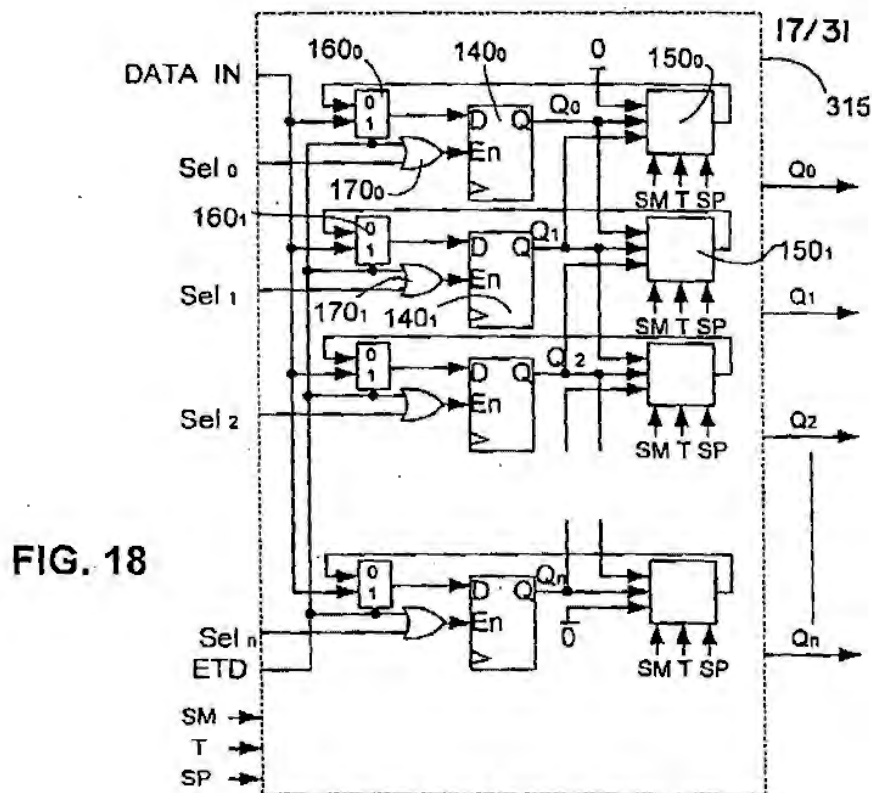

FIG. 18

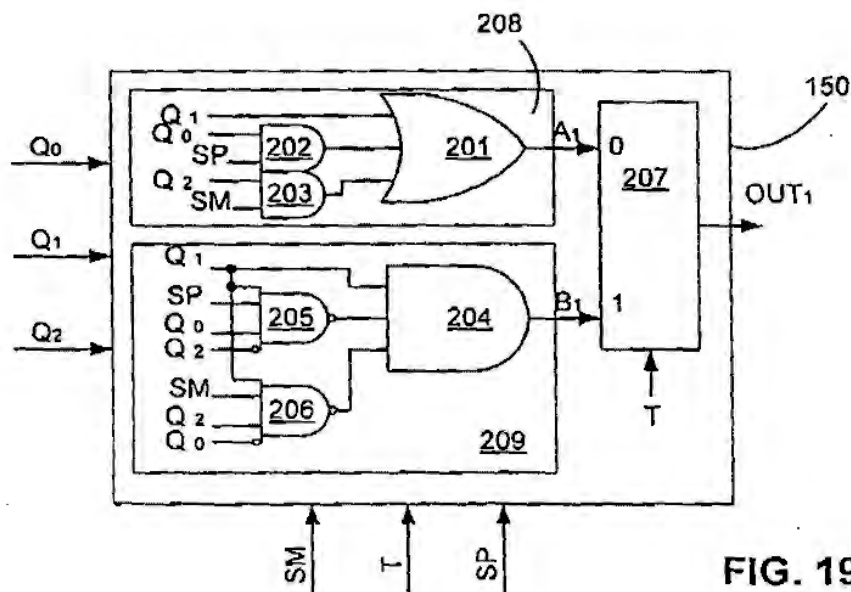

FIG. 19

18/31

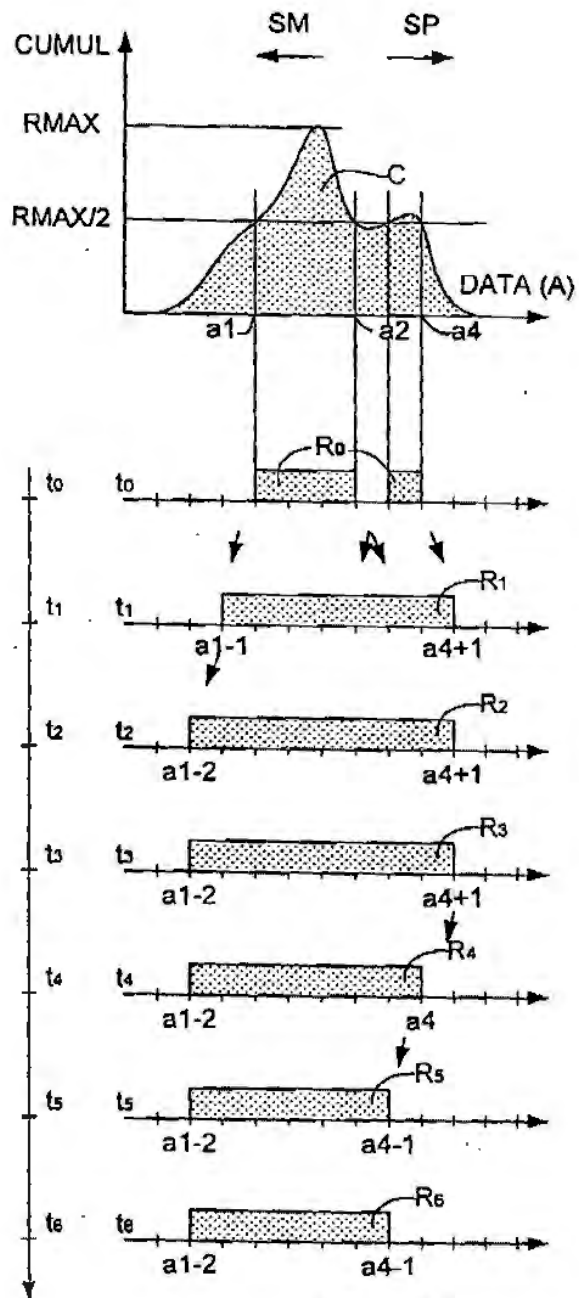
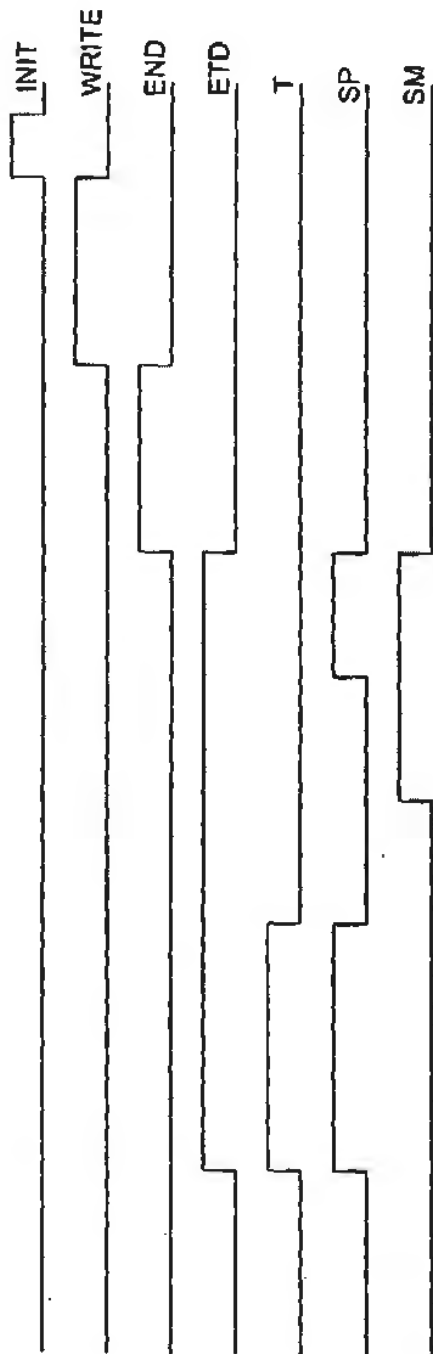

FIG. 20

19/31

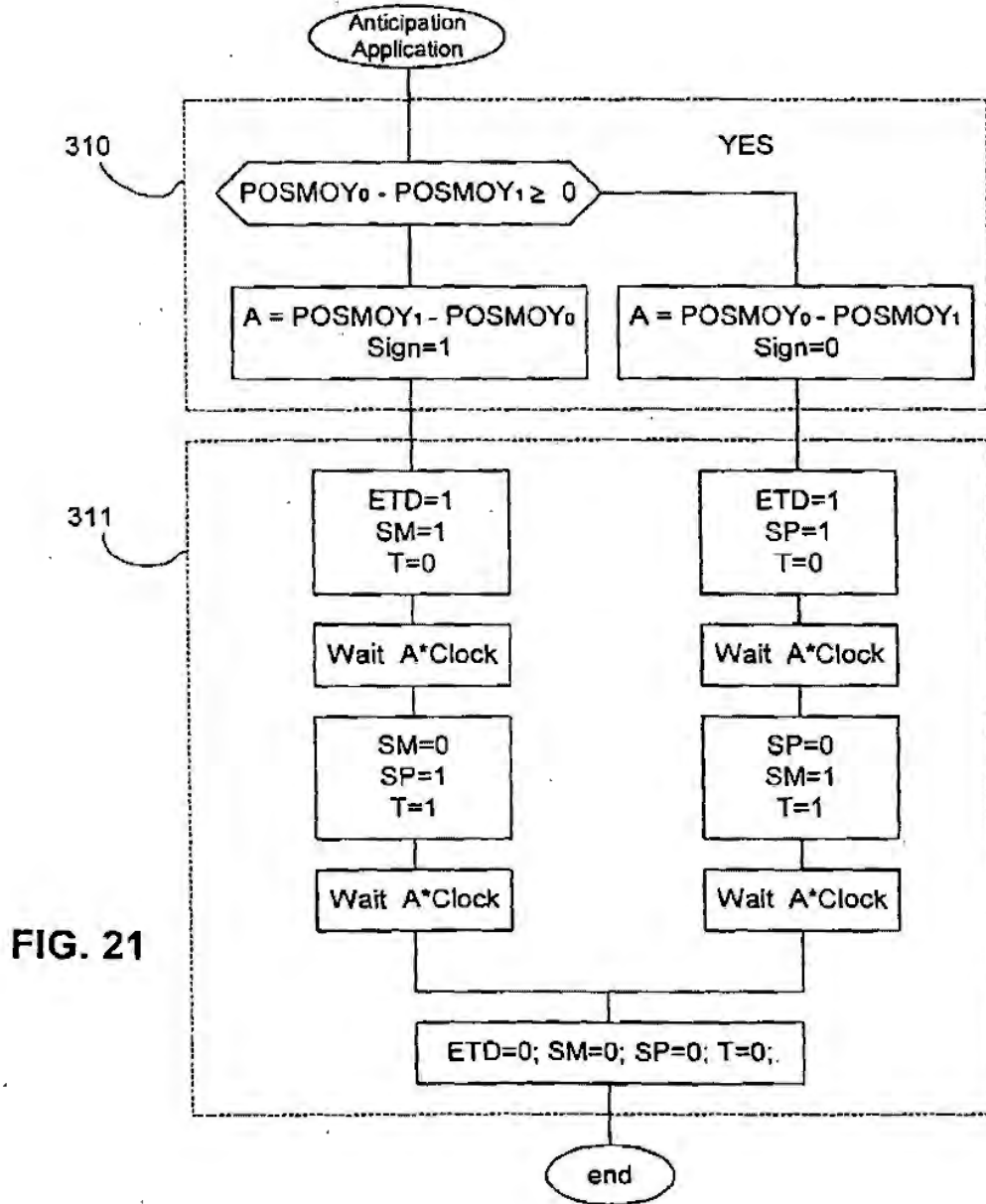

FIG. 21

20/31

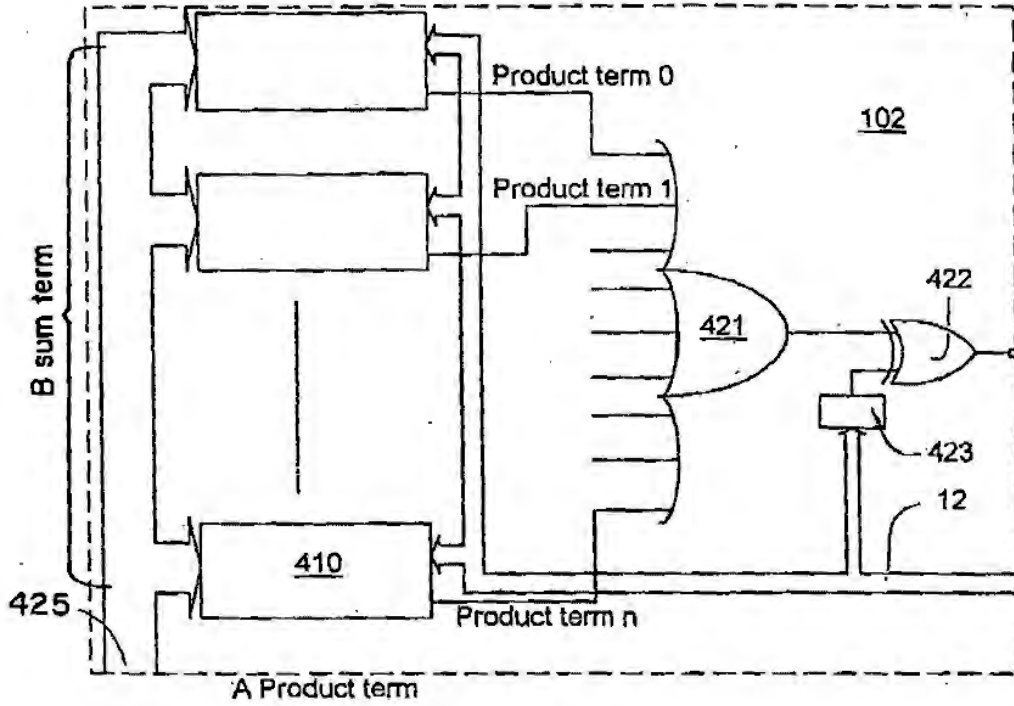

FIG. 22

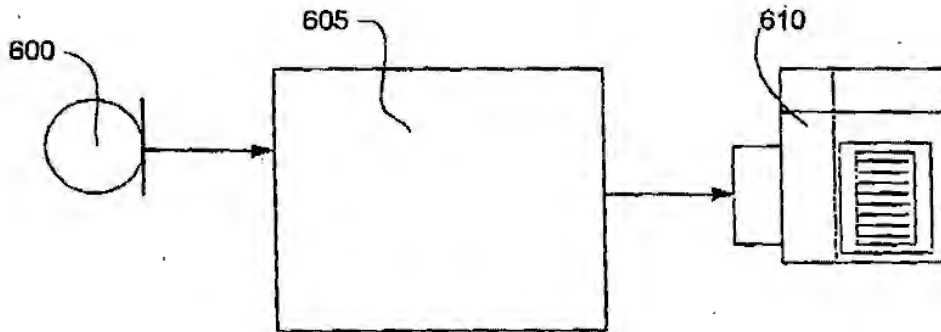

FIG. 39

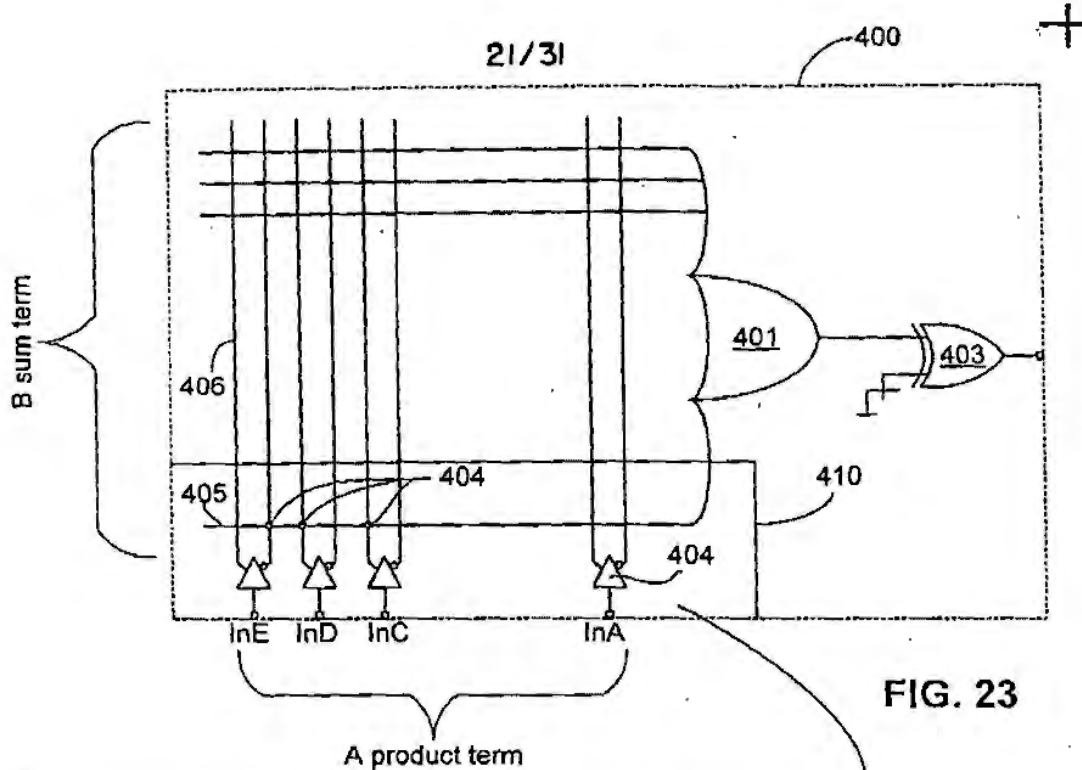

FIG. 23

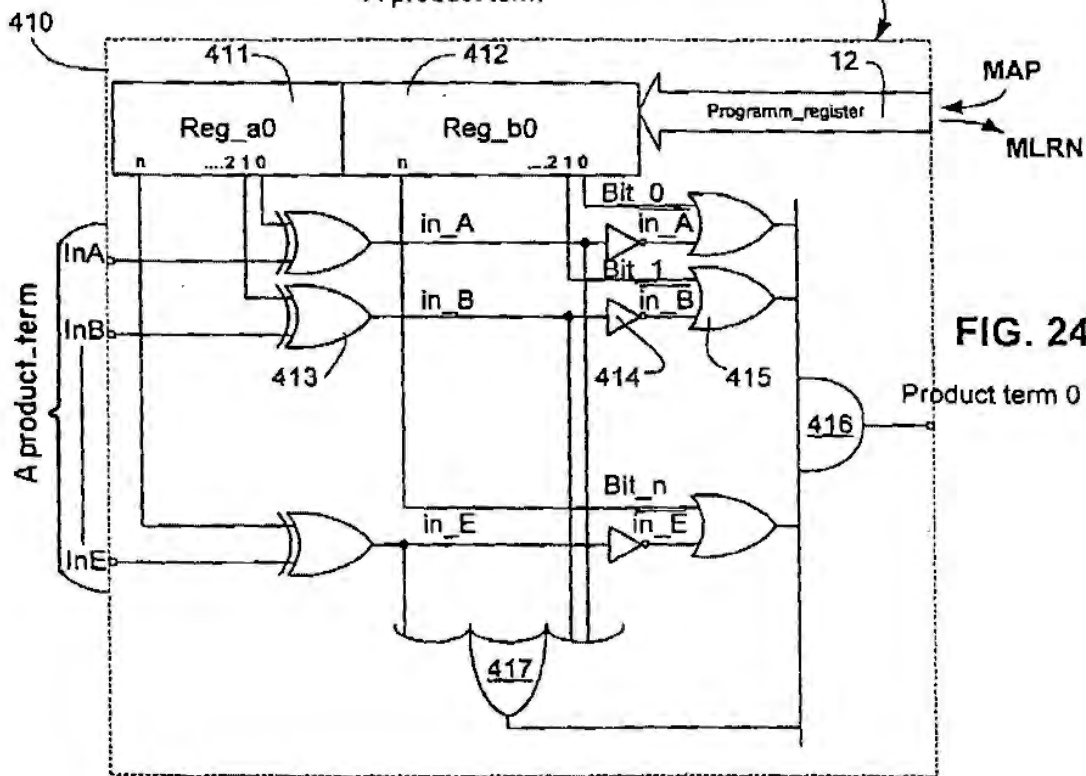

FIG. 24

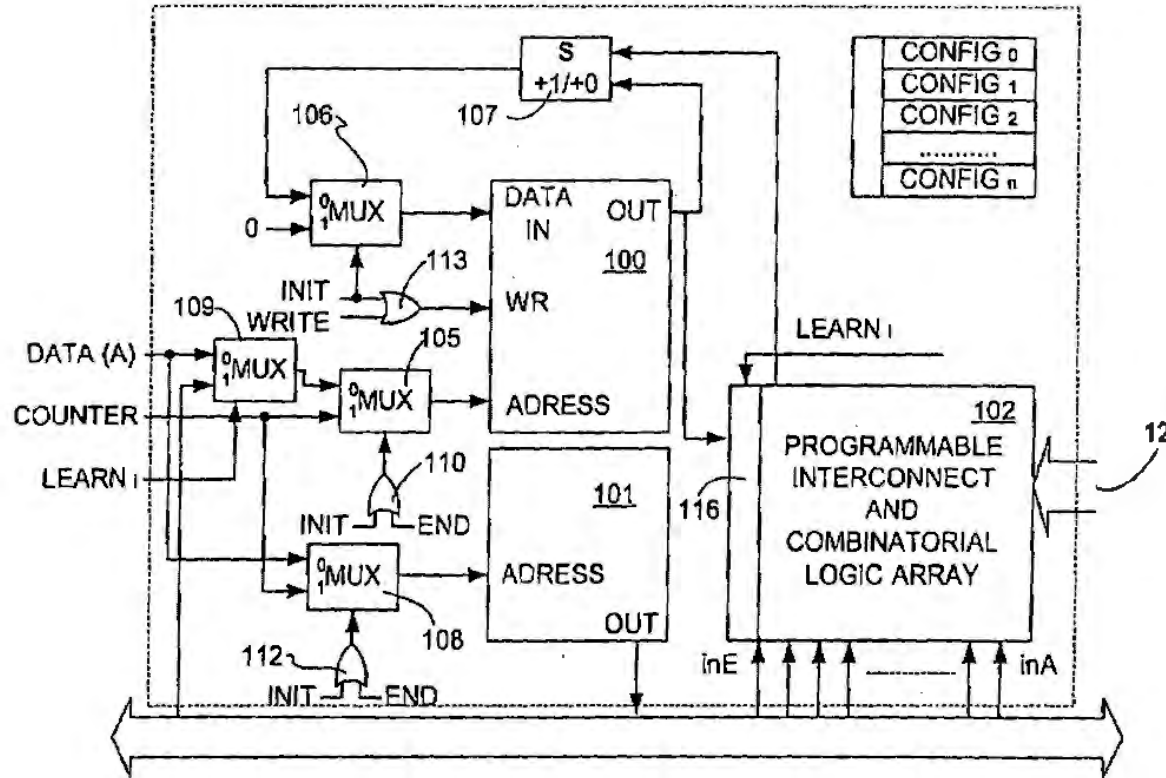
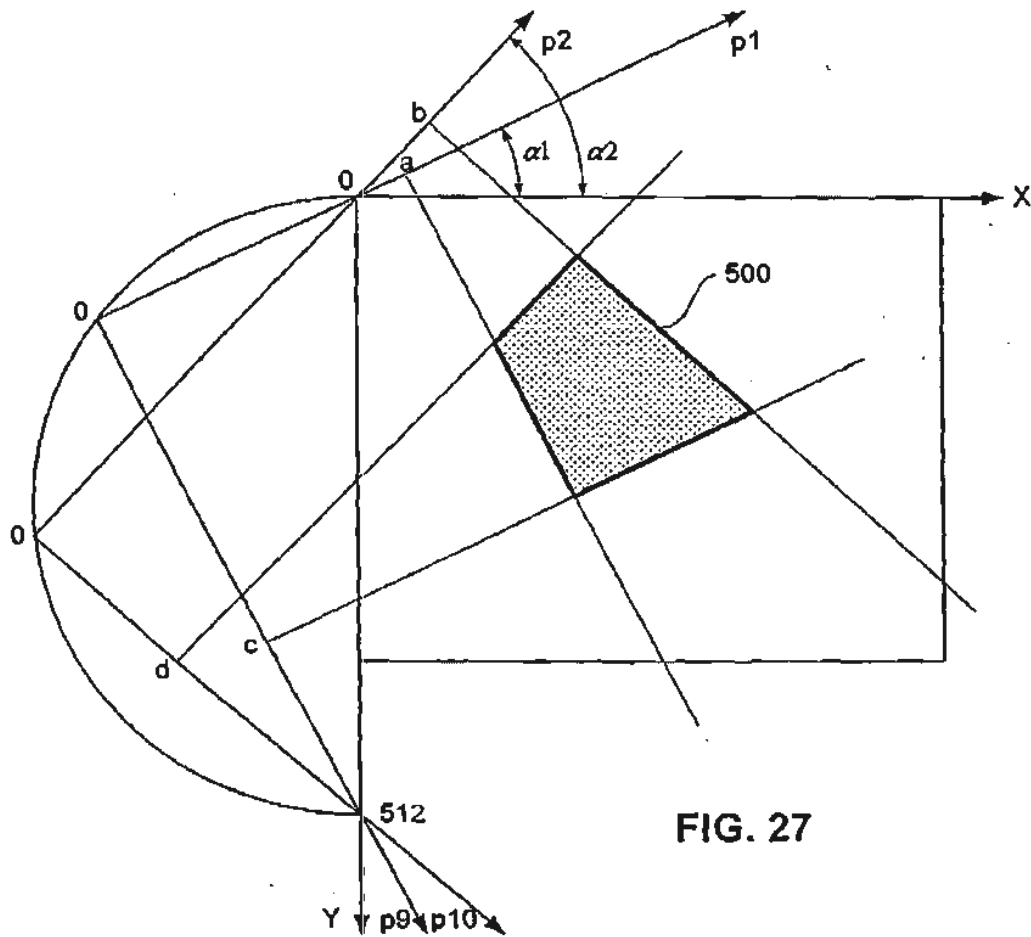
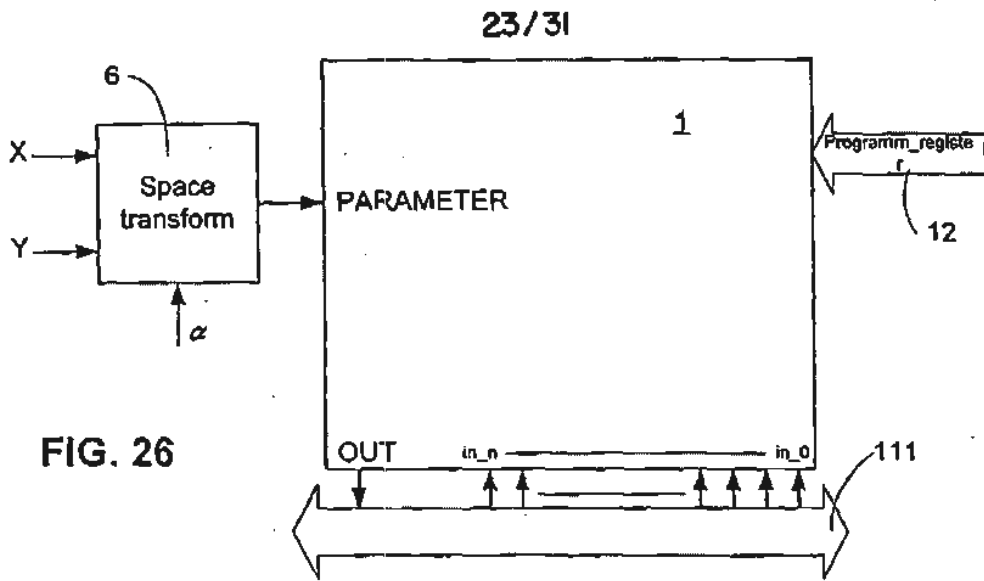

FIG. 25

22/31



24/31

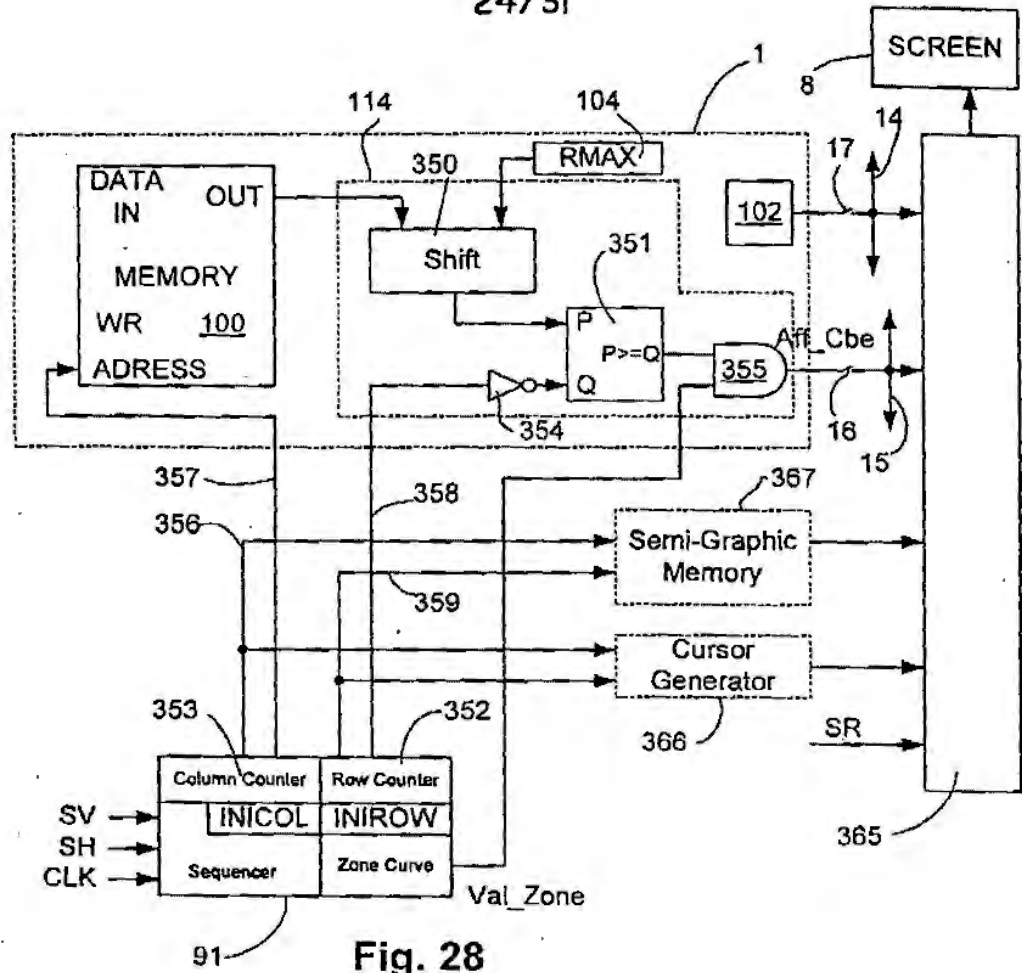

Fig. 28

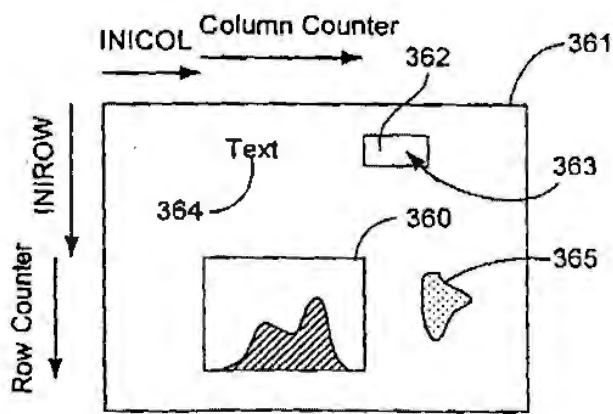
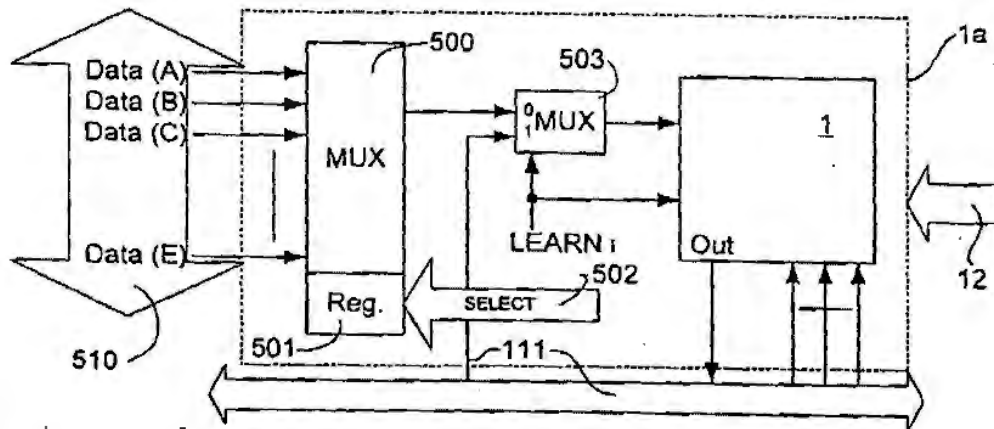
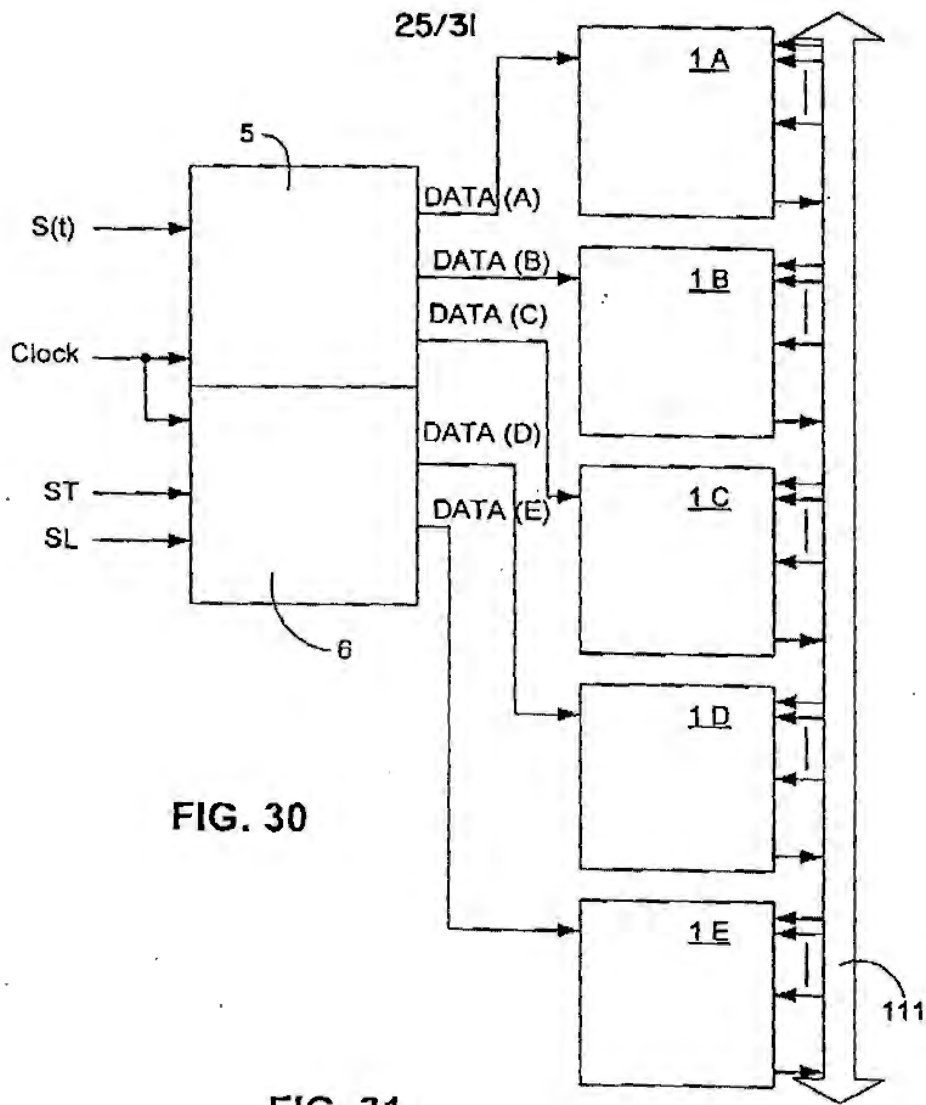

Fig. 29



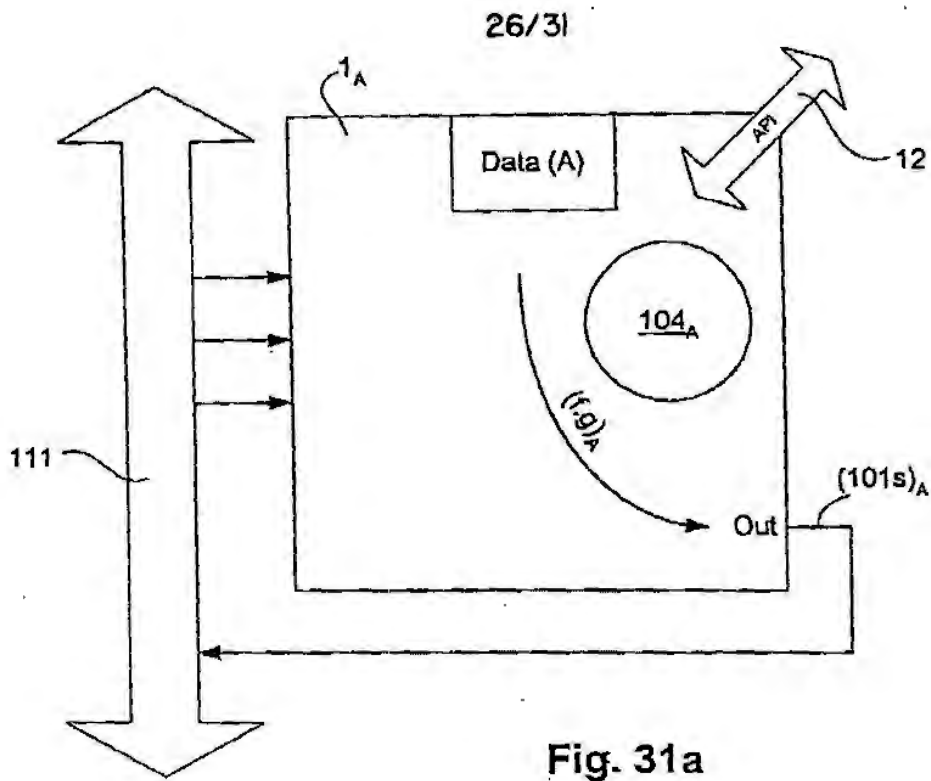

Fig. 31a

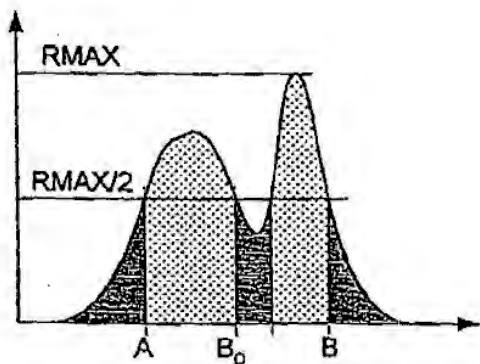

Fig 13a

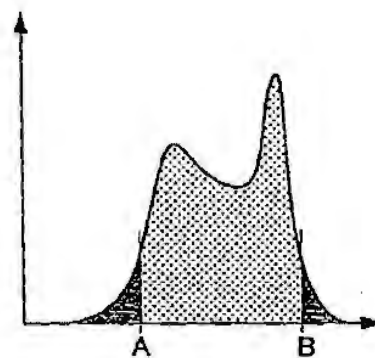

Fig 13b

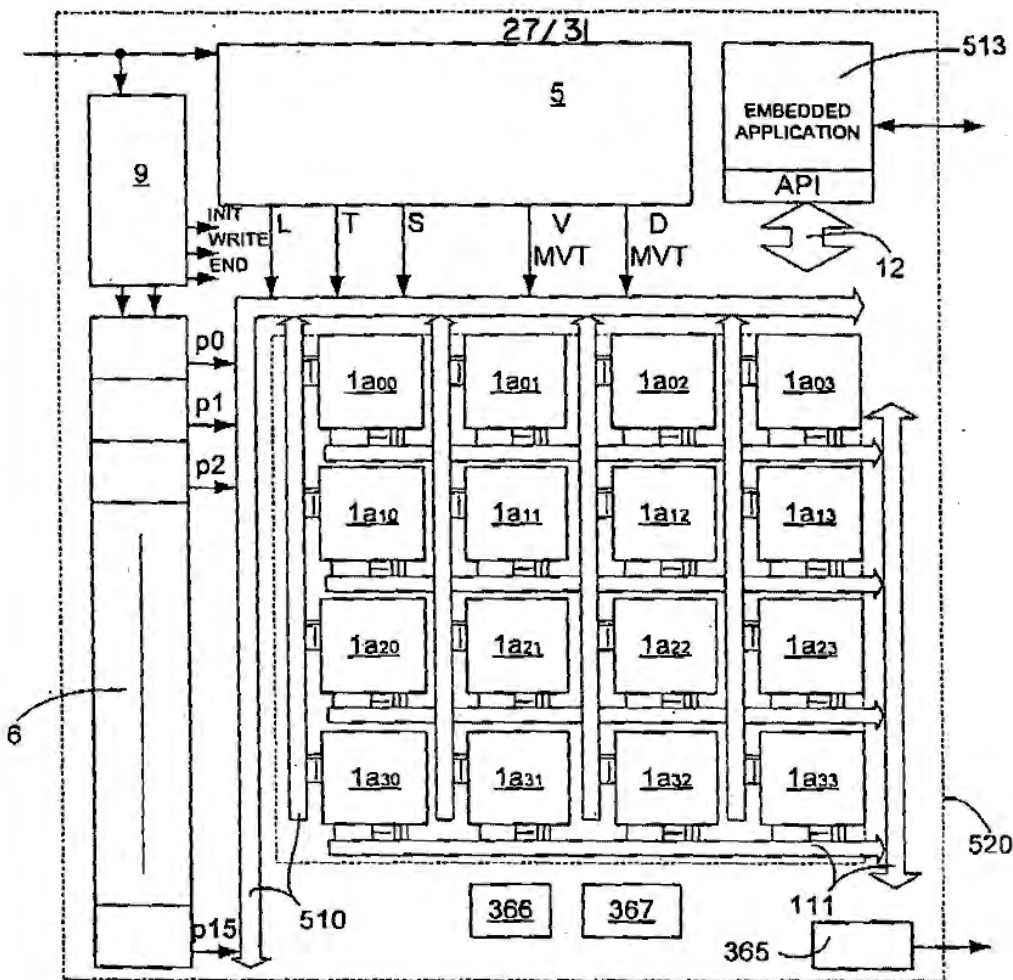

FIG. 32

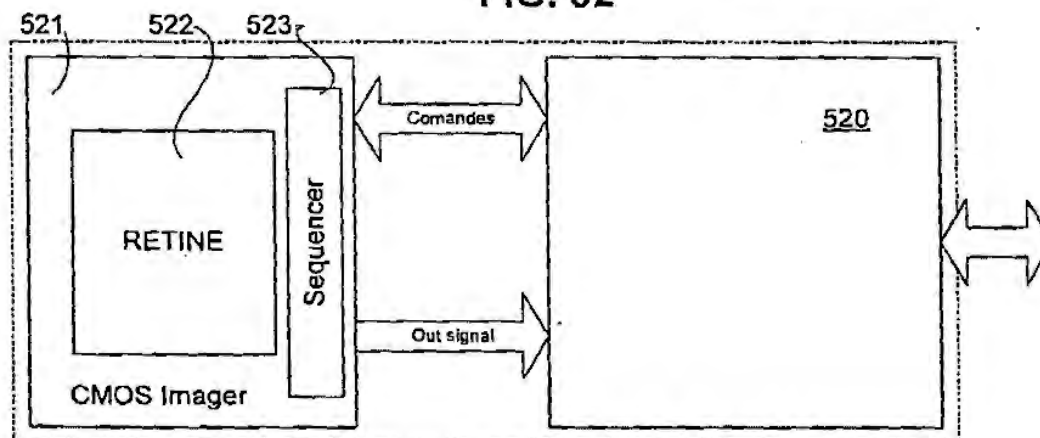

FIG. 33

28/31

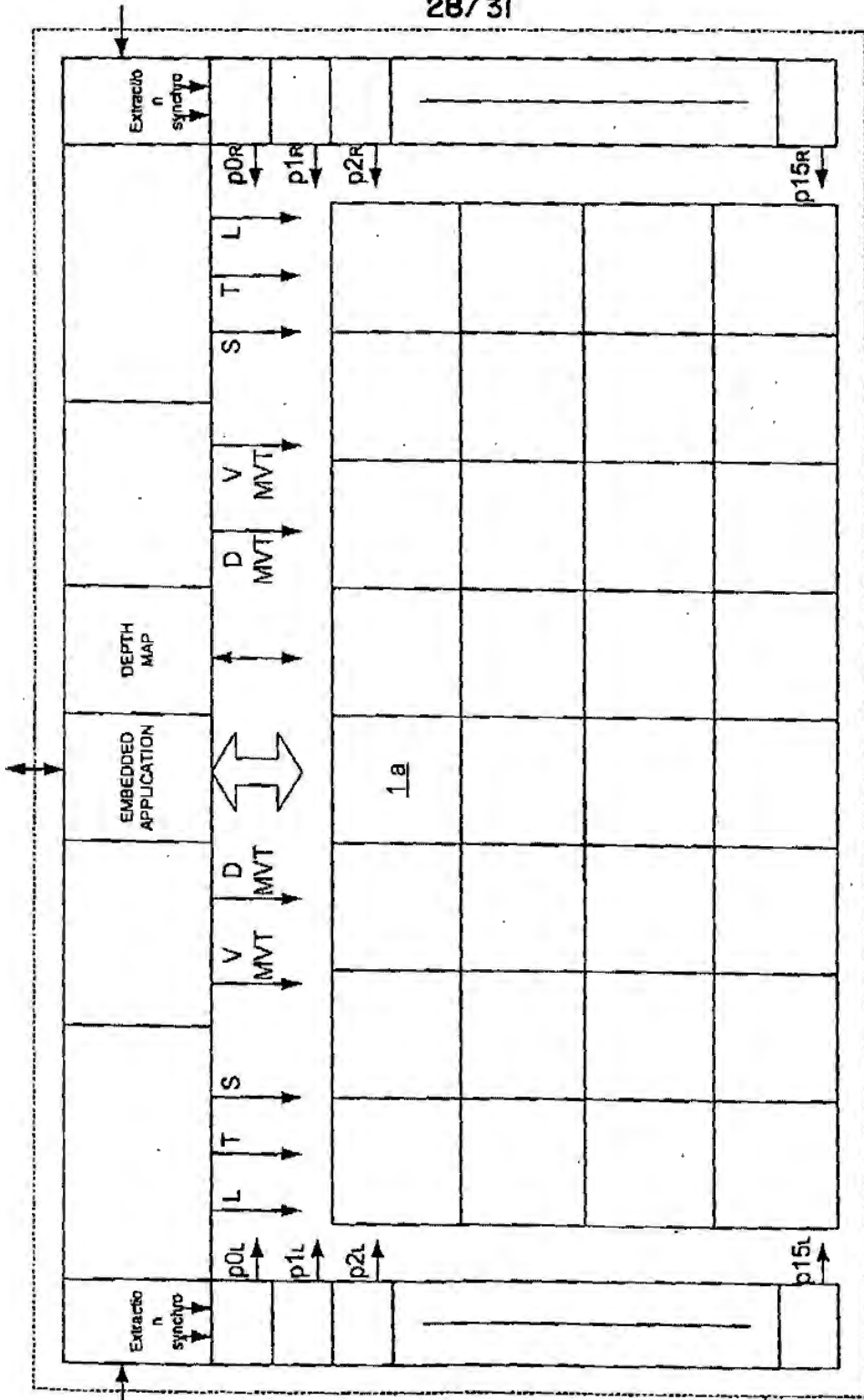

FIG. 34

530

Received from <9254728893> at 4/9/02 5:12:19 PM [Eastern Daylight Time]

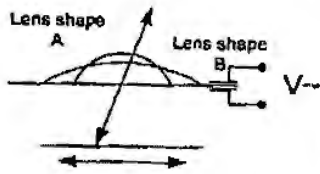
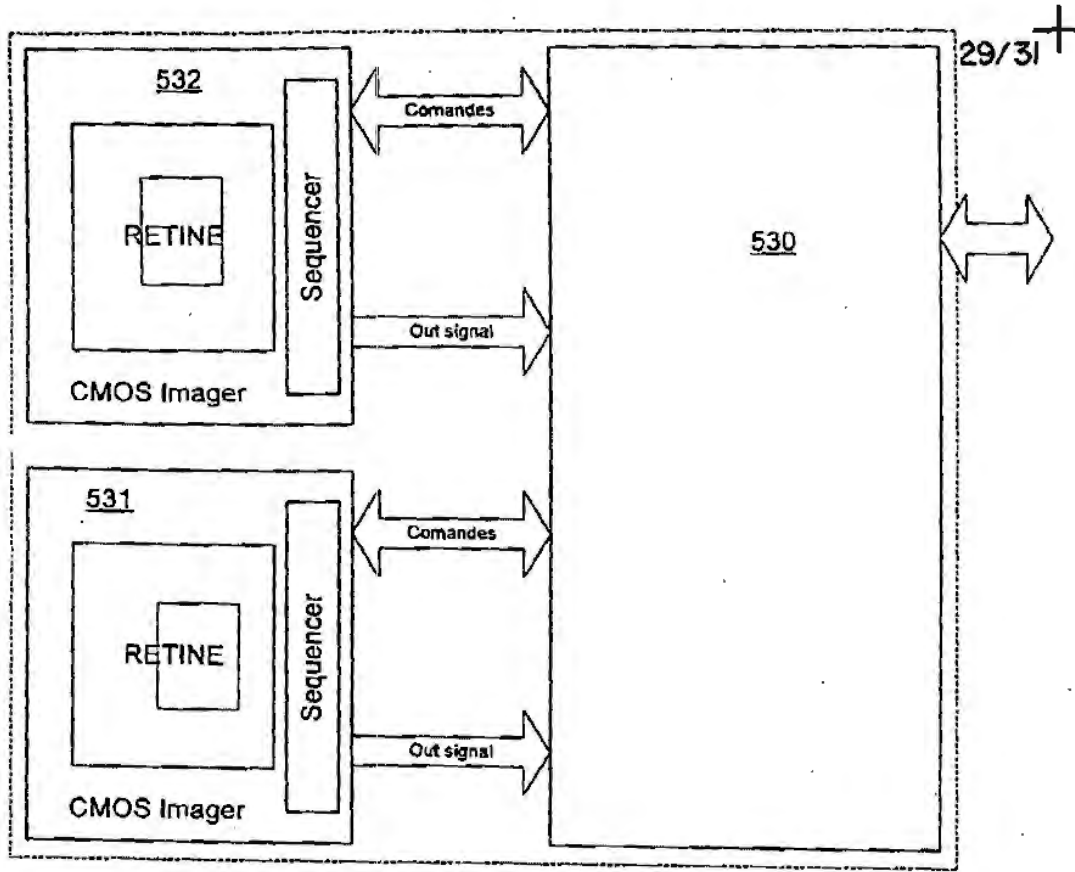

FIG. 36

FIG. 35

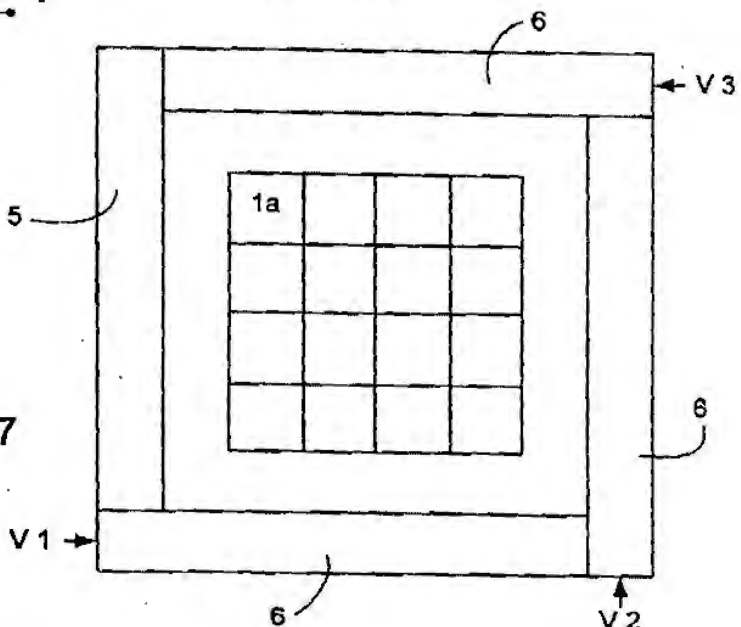

FIG. 37

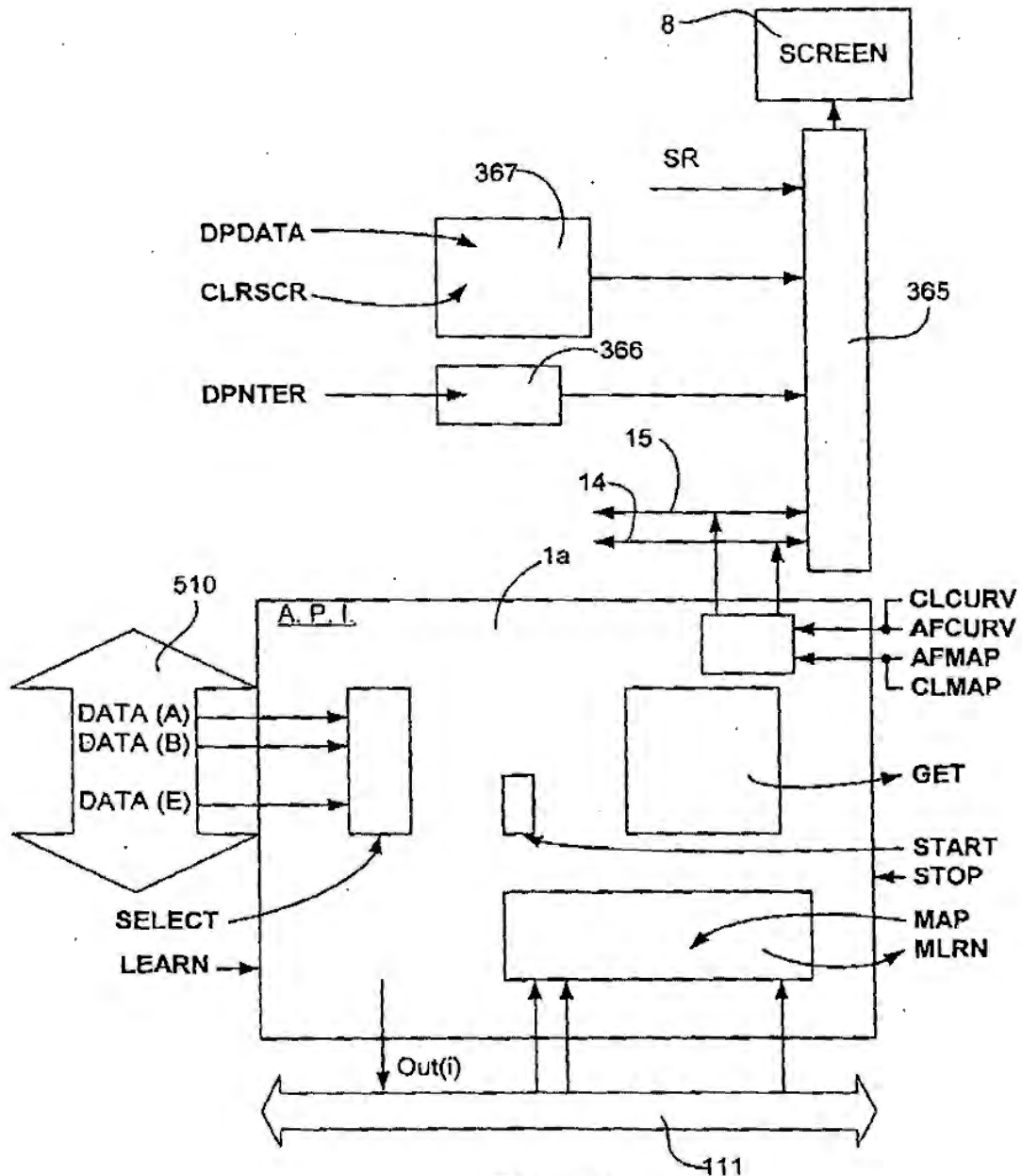

FIG. 38

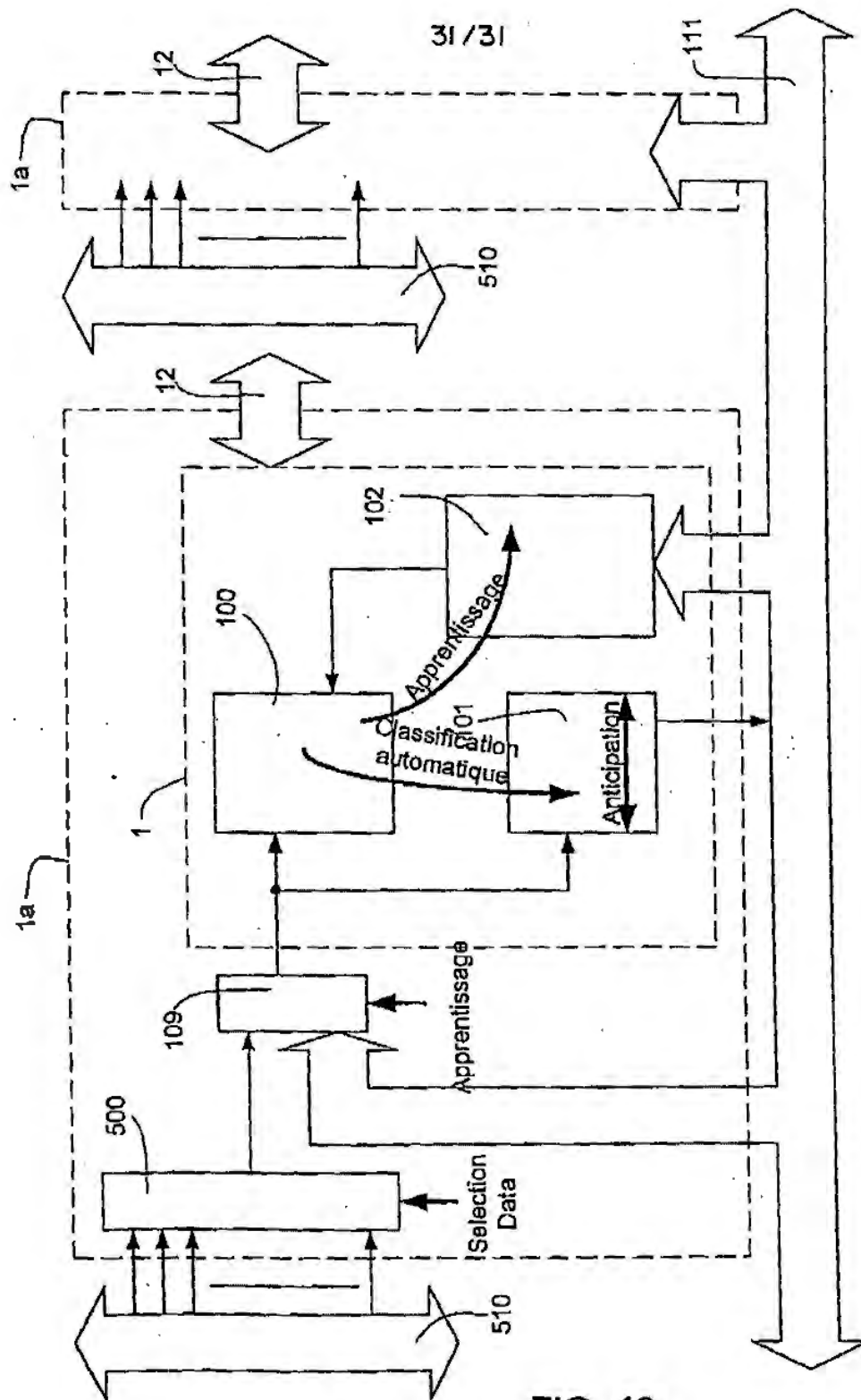

FIG. 40



525

Attorney Docket No.: 20046H-000100US

308L vs

DECLARATION AND POWER OF ATTORNEY

As a below named inventor, I declare that:

My residence, post office address and citizenship are as stated below next to my name; I believe I am the original, first and sole inventor (if only one name is listed below) or an original, first and joint inventor (if plural inventors are named below) of the subject matter which is claimed and for which a patent is sought on the invention entitled: **METHOD AND DEVICE FOR AUTOMATIC VISUAL PERCEPTION** the specification of which _____ is attached hereto or _____ was filed on 02/23/00 as Application No. 09/799136 and was amended on _____ (if applicable).

I have reviewed and understand the contents of the above identified specification, including the claims, as amended by any amendment referred to above. I acknowledge the duty to disclose information which is material to patentability as defined in Title 37, Code of Federal Regulations, Section 1.56. I claim foreign priority benefits under Title 35, United States Code, Section 119 of any foreign application(s) for patent or inventor's certificate listed below and have also identified below any foreign application for patent or inventor's certificate having a filing date before that of the application on which priority is claimed.

Prior Foreign Application(s)

Country	Application No.	Date of Filing	Priority Claimed Under 35 USC 119
France	00 02355	02/24/00	

I hereby claim the benefit under Title 35, United States Code § 119(e) of any United States provisional application(s) listed below:

Application No.	Filing Date

I claim the benefit under Title 35, United States Code, Section 120 of any United States application(s) listed below and, insofar as the subject matter of each of the claims of this application is not disclosed in the prior United States application in the manner provided by the first paragraph of Title 35, United States Code, Section 112, I acknowledge the duty to disclose material information as defined in Title 37, Code of Federal Regulations, Section 1.56 which occurred between the filing date of the prior application and the national or PCT international filing date of this application:

Application No.	Date of Filing	Status

POWER OF ATTORNEY: As a named inventor, I hereby appoint the following attorney(s) and/or agent(s) to prosecute this application and transact all business in the Patent and Trademark Office connected therewith.

Gerald T. Gray, Reg. No. 41,797
Babak S. Sani, Reg. No. 37,495

Send Correspondence to: Gerald T. Gray TOWNSEND and TOWNSEND and CREW LLP Two Embarcadero Center, 8 th Floor San Francisco, California 94111-3834	Direct Telephone Calls to: (Name, Reg. No., Telephone No.) Name: Gerald T. Gray Reg. No.: 41,797 Telephone: 925-472-5000
--	--

TSV

Attorney Docket No.: 20046H-000100US

Full Name of Inventor 1:	Last Name: PIRIM	First Name: PATRICK	Middle Name or Initial:	
Residence & Citizenship:	City: 75013 Paris	State/Foreign Country: France	Country of Citizenship: France	
Post Office Address:	Post Office Address: 56 Rue Patay	City: 75013 Paris	State/Country: France	Postal Code:

I further declare that all statements made herein of my own knowledge are true and that all statements made on information and belief are believed to be true; and further that these statements were made with the knowledge that willful false statements and the like so made are punishable by fine or imprisonment, or both, under Section 1001 of Title 18 of the United States Code, and that such willful false statements may jeopardize the validity of the application or any patent issuing thereon.

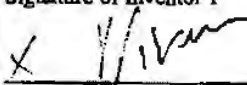
Signature of Inventor 1 
Patrick Pirim
Date: <u>4-25-02-1001</u>

SF 1193098 v1

2 of 2

Received from <9254728893> at 4/9/02 5:12:19 PM [Eastern Daylight Time]

Petitioner LG Ex-1004, 0475

Approved through 10/31/2002, OMB 065-1-0031
U.S. Patent and Trademark Office, U.S. DEPARTMENT OF COMMERCE
Under the Paperwork Reduction Act of 1995, no persons are required to respond to a collection of information unless it displays a valid OMB control number.

PETITION FOR EXTENSION OF TIME UNDER 37 CFR 1.136(a)		Docket Number (Optional) 20046H-000100US
In re Application of Patrick Pirim		
Application Number 09/792,436	Filed February 23, 2001	
For METHOD AND DEVICE FOR AUTOMATIC VISUAL PERCEPTION		
Group Art Unit 2122	Examiner	

OIP E
APR 09 2002
T.R. BADEL, P.K. DEE

This is a request under the provisions of 37 CFR 1.136(a) to extend the period for filing a reply in the above identified application.

The requested extension and appropriate non-small-entity fee are as follows (check time period desired):

- One month (37 CFR 1.17(a)(1)) \$
- Two months (37 CFR 1.17(a)(2)) \$
- Three months (37 CFR 1.17(a)(3)) \$
- Four months (37 CFR 1.17(a)(4)) \$
- Five months (37 CFR 1.17(a)(5)) \$1960

Applicant claims small entity status. See 37 CFR 1.27. Therefore, the fee amount shown above is reduced by one-half, and the resulting fee is: \$.

A check in the amount of the fee is enclosed.

Payment by credit card. Form PTO-2038 is attached.

The Commissioner has already been authorized to charge fees in this application to a Deposit Account.

The Commissioner is hereby authorized to charge any fees which may be required, or credit any overpayment, to Deposit Account Number 20-1430.

I have enclosed a duplicate copy of this sheet.

I am the applicant/inventor.

assignee of record of the entire interest. See 37 CFR 3.71
Statement under 37 CFR 3.73(b) is enclosed. (Form PTO/SB/96).

attorney or agent of record.

attorney or agent under 37 CFR 1.34(a).
Registration number if acting under 37 CFR 1.34(a): 41,797.

WARNING: Information on this form may become public. Credit card information should not be included on this form. Provide credit card information and authorization on PTO-2038.

10/22/01
Date

Gerald T. Gray
Signature
Gerald T. Gray, Reg. No. 41,797
Typed or printed name

NOTE: Signatures of all the inventors or assignees of record of the entire interest or their representative(s) are required. Submit multiple forms if more than one signature is required, see below.

Total of _____ forms are submitted.

Burden Hour Statement: This form is estimated to take 0.1 hours to complete. Time will vary depending upon the needs of the individual case. Any comments on the amount of time you are required to complete this form should be sent to the Chief Information Officer, U.S. Patent and Trademark Office, Washington, DC 20231. DO NOT SEND FEES OR COMPLETED FORMS TO THIS ADDRESS. SEND TO: Assistant Commissioner for Patents, Washington, DC 20231.

AK



UNITED STATES PATENT AND TRADEMARK OFFICE

COMMISSIONER FOR PATENTS
UNITED STATES PATENT AND TRADEMARK OFFICE
WASHINGTON, D.C. 20231
www.uspto.gov

APPLICATION NUMBER	FILING/RECEIPT DATE	FIRST NAMED APPLICANT	ATTORNEY DOCKET NUMBER
09/792,436	02/23/2001	Patrick Pirim	20046H-000100US

CONFIRMATION NO. 9956

20350
TOWNSEND AND TOWNSEND AND CREW
TWO EMBARCADERO CENTER
EIGHTH FLOOR
SAN FRANCISCO, CA 94111-3834



FORMALITIES LETTER



Date Mailed: 03/23/2001

NOTICE TO FILE MISSING PARTS OF NONPROVISIONAL APPLICATION

FILED UNDER 37 CFR 1.53(b)

Filing Date Granted

COPY OF PAPERS
ORIGINALLY FILED
01/27/02

An application number and filing date have been accorded to this application. The item(s) indicated below, however, are missing. Applicant is given TWO MONTHS from the date of this Notice within which to file all required items and pay any fees required below to avoid abandonment. Extensions of time may be obtained by filing a petition accompanied by the extension fee under the provisions of 37 CFR 1.136(a).

- The statutory basic filing fee is missing.
Applicant must submit \$ 710 to complete the basic filing fee and/or file a small entity statement claiming such status (37 CFR 1.27).
- Total additional claim fee(s) for this application is \$384.
 - \$144 for 8 total claims over 20.
 - \$240 for 3 independent claims over 3 .
- The oath or declaration is unsigned.
- To avoid abandonment, a late filing fee or oath or declaration surcharge as set forth in 37 CFR 1.16(e) of \$130 for a non-small entity, must be submitted with the missing items identified in this letter.
- The balance due by applicant is \$ 1224.

The application is informal since it does not comply with the regulations for the reason(s) indicated below. Applicant is given TWO MONTHS from the date of this Notice within which to correct the informalities indicated below.

The required item(s) identified below must be timely submitted to avoid abandonment:

- Substitute drawings in compliance with 37 CFR 1.84 because:
 - drawing sheets do not have the appropriate margin(s) (see 37 CFR 1.84(g)). Each sheet must include a top margin of at least 2.5 cm. (1 inch), a left side margin of at least 2.5 cm. (1 inch), a right side margin of at least 1.5 cm. (5/8 inch), and a bottom margin of at least 1.0 cm. (3/8 inch);

*A copy of this notice **MUST** be returned with the reply.*

Customer Service Center
Initial Patent Examination Division (703) 308-1202
PART 2 - COPY TO BE RETURNED WITH RESPONSE

20020409 13:05 FAX 92547288

09792436 0500 001



Atty Docket No. 20046H-000100
Serial No. 09/792,436

PTO FAX NO.: 703-746-4060 (OIPE)
ATTENTION: BOX DUPLICATE OIPE

**OFFICIAL COMMUNICATION
FOR THE PERSONAL ATTENTION OF
BOX DUPLICATE OIPE**

CERTIFICATION OF FACSIMILE TRANSMISSION

I hereby certify that the following documents, in re Application of Patrick Pirim, Application No. 09/792,436 filed 02/23/01, for METHOD AND DEVICE FOR AUTOMATIC VISUAL PERCEPTION are being facsimile transmitted to the Patent and Trademark Office, **Box Duplicate OIPE** on the date shown below.

Documents Attached

1. Transmittal
2. Fee Transmittal
3. Petition to Extend Time
4. Declaration
5. Copy of Notice to be returned (Notice to File Missing Parts)
6. 31 Sheets of Substitute Drawings
7. Request for Substitute Papers copy to be returned
8. Copy of acknowledgement postcard

Number of pages being transmitted, including this page: 41

Dated: April 9, 2002

Jennifer K. Hardin

**PLEASE CONFIRM RECEIPT OF THIS PAPER BY
RETURN FACSIMILE AT (925-) 472-8895**

TOWNSEND and TOWNSEND and CREW LLP
Two Embarcadero Center, 8th Floor
San Francisco, CA 94111-3834
Telephone: (415) 576-0200 / Fax: (415) 576-0300

Received from < 9254728893 > at 4/9/02 5:12:19 PM [Eastern Daylight Time]

200-464-000100 6TG



UNITED STATES PATENT AND TRADEMARK OFFICE

UNITED STATES DEPARTMENT OF COMMERCE
United States Patent and Trademark Office
Address: COMMISSIONER OF PATENTS AND TRADEMARKS
Washington, D.C. 20231
www.uspto.gov

Application Number	Filing Date	First Named Applicant	Atty. Docket No.
09/792,436	02/23/2001	Pirim, Patrick	20046H-000100US

20350
TOWNSEND AND TOWNSEND AND CREW, LLP
TWO EMBARCADERO CENTER
EIGHTH FLOOR
SAN FRANCISCO CA 94111-3834

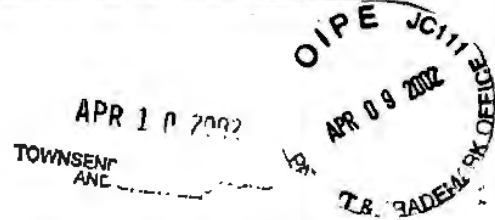

Title: Method and device for automatic visual perception

Date Mailed: 03/22/2002

Request for Substitute Papers

The papers filed on 01/22/02 (certificate of mailing dated 10/22/01) are no longer in condition to become part of the permanent records of the United States Patent and Trademark Office (USPTO) for this application (37 CFR 1.52(a)) due to the United States Postal Service sanitization process.

The USPTO requests that applicant provide a copy of the above-identified papers (except for any U.S. or foreign patent documents submitted with the above-identified papers) with a statement that such copy is a complete and accurate copy of the above-identified papers (signing and returning a copy of this notice will provide such a statement). The reply to this letter should be submitted to the USPTO by facsimile at the number indicated **703-746-4060(OIPE)**.

Alternatively, the reply to this letter may be hand-carried to the Customer Service Window located in Room 1B03 of Crystal Plaza Building 2, Arlington, Virginia, 22202.

The USPTO **strongly** prefers that the reply to this letter be submitted by facsimile. However, if applicant cannot submit the reply to this letter by facsimile (or hand-delivery), the reply may be mailed to: Box Duplicate OIPE, U.S. Patent and Trademark Office, P.O. Box 2327, Arlington, VA 22202-2327.

This letter is not a notice under 37 CFR 1.251. However, failure to timely replay to this notice within **two (2) weeks** of the date of receipt of this letter may result in the USPTO issuing a notice under 37 CFR 1.251. **A copy of this notice should be included with the reply.**

The enclosed papers are a complete and accurate copy of the above-identified papers.

Name: Gerald T. Gray Registration No.: 41,797

Signature: *Gerald T. Gray* Date: 04/09/02

MISSING PARTS
TO THE U.S. PATENT AND TRADEMARK OFFICE
Please stamp the date of receipt of the following document(s) and return this card to us

RE: PATRICK PIRIM
TITLE OF DOCUMENT(S): Fee Transmittal (+ copy), Transmittal, Executed Declaration, Part 2- copy to be returned, Petition to Extend Time (+ copy)
31 Sheets - Substitute Drawings
Application No.: 09/792,436
File No. 22046H-000100
Date Due 10/23/01
Date Mailed: 10/22/01
Atty/Secty. GTG/ikh
SF 1018344 v1



MISSING PARTS
TO THE U.S. PATENT AND TRADEMARK OFFICE
Please stamp the date of receipt of the following document(s) and return this card to us

RE: PATRICK PIRIM
TITLE OF DOCUMENT(S): Fee Transmittal (+ copy), Transmittal, Executed Declaration, Part 2- copy to be returned, Petition to Extend Time (+ copy)
31 Sheets - Substitute Drawings
Application No.: 09/792,436
File No. 22046H-000100
Date Due 10/23/01
Date Mailed: 10/22/01
Atty/Secty. GTG/ikh
SF 1018344 v1

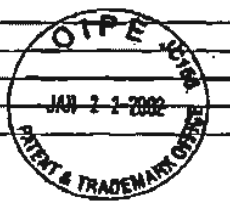

APR 02 2002

Handwritten initials and a circled '6'.

PTO/SB/21 (08-00)

Please type a plus sign (+) inside this box →

Approved for use through 10/31/2002. OMB 0651-0031
U.S. Patent and Trademark Office: U.S. DEPARTMENT OF COMMERCE

Under the Paperwork Reduction Act of 1995, no persons are required to respond to a collection of information unless it displays a valid OMB control number.

TRANSMITTAL FORM (to be used for all correspondence after initial filing)	Application Number	09/792,436	
	Filing Date	February 23, 2001	
	First Named Inventor	Pirm, Patrick	
	Group Art Unit	2122	
	Examiner Name		
Total Number of Pages in This Submission	38	Attorney Docket Number	20046H-000100

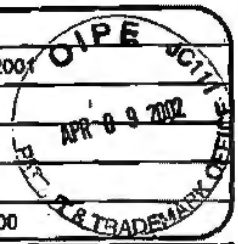

ENCLOSURES (check all that apply)		
<input checked="" type="checkbox"/> Fee Transmittal Form <input type="checkbox"/> Fee Attached <input type="checkbox"/> Amendment / Response <input type="checkbox"/> After Final <input type="checkbox"/> Affidavits/declaration(s) <input checked="" type="checkbox"/> Extension of Time Request <input type="checkbox"/> Express Abandonment Request <input type="checkbox"/> Information Disclosure Statement <input type="checkbox"/> Certified Copy of Priority Document(s) <input type="checkbox"/> Response to Missing Parts/ Incomplete Application <input checked="" type="checkbox"/> Response to Missing Parts under 37 CFR 1.52 or 1.63	<input type="checkbox"/> Assignment Papers (for an Application) <input checked="" type="checkbox"/> Drawing(s) Substitute 31 pages <input type="checkbox"/> Licensing-related Papers <input type="checkbox"/> Petition Routing Slip (PTO/SB/89) and Accompanying Petition <input type="checkbox"/> Petition to Convert to a Provisional Application <input type="checkbox"/> Power of Attorney, Revocation Change of Correspondence Address <input type="checkbox"/> Terminal Disclaimer <input type="checkbox"/> Request for Refund <input type="checkbox"/> CD, Number of CD(s)	<input type="checkbox"/> After Allowance Communication to Group <input type="checkbox"/> Appeal Communication to Board of Appeals and Interferences <input type="checkbox"/> Appeal Communication to Group (Appeal Notice, Brief, Reply Brief) <input type="checkbox"/> Proprietary Information <input type="checkbox"/> Status Letter <input checked="" type="checkbox"/> Other Enclosure(s) (please identify below): Return Postcard Executed Declaration Part 2- Copy to be returned
Remarks		The Commissioner is authorized to charge any additional fees to Deposit Account 20-1430.

COPY OF PAPERS ORIGINALLY FILED 01/12/02

SIGNATURE OF APPLICANT, ATTORNEY, OR AGENT		
Firm and individual name	Townsend and Townsend and Crew LLP Gerald T. Gray Reg No. 41,797	
Signature	<i>Gerald T. Gray</i>	
Date	10/22/01	

CERTIFICATE OF MAILING			
I hereby certify that this correspondence is being deposited with the United States Postal Service with sufficient postage as first class mail in an envelope addressed to: Assistant Commissioner for Patents, Washington, D.C. 20231 on this date:			
			10/22/01
Typed or printed name	Jennifer K. Hardin		
Signature	<i>Jennifer K. Hardin</i>	Date	10/22/01

Burden Hour Statement: This form is estimated to take 0.2 hours to complete. Time will vary depending upon the needs of the individual case. No comments on the amount of time you are required to complete this form should be sent to the Chief Information Officer, U.S. Patent and Trademark Office, Washington, DC 20231. DO NOT SEND FEES OR COMPLETED FORMS TO THIS ADDRESS. SEND TO: Assistant Commissioner for Patents, Washington, DC 20231.

PTOGBM7 (09-00)
 Appr. for use through 10/3/2002. OMB 0651-0032
 Patent and Trademark Office: U.S. DEPARTMENT OF COMMERCE

Under the Paperwork Reduction Act of 1995, no persons are required to respond to a collection of information unless it displays a valid OMB control number.

<h2>FEE TRANSMITTAL for FY 2001</h2> <p><i>Patent fees are subject to annual revision.</i></p>	Complete if Known		
	Application Number	06782,436	
	Filing Date	February 23, 2001	
	First Named Inventor	Pirim, Patrick	
	Examiner Name		
	Group Art Unit	2122	
TOTAL AMOUNT OF PAYMENT (\$)	3226	Attorney Docket No.	20048H-000100US



METHOD OF PAYMENT 1. <input checked="" type="checkbox"/> The Commissioner is hereby authorized to charge indicated fees and credit any over payments to: Deposit Account Number: 20-1430 Deposit Account Name: Townsend and Townsend and Crew LLP <input checked="" type="checkbox"/> Change Any Additional Fee Required Under 37 CFR 1.16 and 1.17 <input type="checkbox"/> Applicant claims small entity status. See 37 CFR 1.27		3. ADDITIONAL FEES <table border="1"> <thead> <tr> <th>Large Fee Code</th> <th>Entity Fee (\$)</th> <th>Small Fee Code</th> <th>Entity Fee (\$)</th> <th>Fee Description</th> <th>Fee Paid</th> </tr> </thead> <tbody> <tr><td>105</td><td>130</td><td>205</td><td>65</td><td>Surcharge - late filing fee or oath</td><td>130</td></tr> <tr><td>127</td><td>50</td><td>227</td><td>25</td><td>Surcharge - late provisional filing fee or cover sheet</td><td></td></tr> <tr><td>139</td><td>130</td><td>139</td><td>130</td><td>Non-English specification</td><td></td></tr> <tr><td>147</td><td>2,520</td><td>147</td><td>2,520</td><td>For filing a request for reexamination</td><td></td></tr> <tr><td>112</td><td>920*</td><td>112</td><td>920*</td><td>Requesting publication of SIR prior to Examiner action</td><td></td></tr> <tr><td>113</td><td>1,840*</td><td>113</td><td>1,840*</td><td>Requesting publication of SIR after Examiner action</td><td></td></tr> <tr><td>115</td><td>110</td><td>215</td><td>55</td><td>Extension for reply within first month</td><td></td></tr> <tr><td>116</td><td>390</td><td>216</td><td>195</td><td>Extension for reply within second month</td><td></td></tr> <tr><td>117</td><td>660</td><td>217</td><td>445</td><td>Extension for reply within third month</td><td></td></tr> <tr><td>118</td><td>1,190</td><td>218</td><td>695</td><td>Extension for reply within fourth month</td><td></td></tr> <tr><td>128</td><td>1,890</td><td>228</td><td>945</td><td>Extension for reply within fifth month</td><td>1890</td></tr> <tr><td>119</td><td>310</td><td>219</td><td>155</td><td>Notice of Appeal</td><td></td></tr> <tr><td>120</td><td>310</td><td>220</td><td>155</td><td>Filing a brief in support of an appeal</td><td></td></tr> <tr><td>121</td><td>270</td><td>221</td><td>135</td><td>Request for oral hearing</td><td></td></tr> <tr><td>138</td><td>1,510</td><td>138</td><td>1,510</td><td>Petition to institute a public use proceeding</td><td></td></tr> <tr><td>140</td><td>110</td><td>240</td><td>55</td><td>Petition to revive - unavoidable</td><td></td></tr> <tr><td>141</td><td>1,240</td><td>241</td><td>620</td><td>Petition to revive - unintentional</td><td></td></tr> <tr><td>142</td><td>1,240</td><td>242</td><td>620</td><td>Utility issue fee (or rehear)</td><td></td></tr> <tr><td>143</td><td>440</td><td>243</td><td>220</td><td>Design issue fee</td><td></td></tr> <tr><td>144</td><td>600</td><td>244</td><td>300</td><td>Plant issue fee</td><td></td></tr> <tr><td>122</td><td>130</td><td>122</td><td>130</td><td>Petitions to the Commissioner</td><td></td></tr> <tr><td>123</td><td>50</td><td>123</td><td>50</td><td>Petitions related to provisional applications</td><td></td></tr> <tr><td>129</td><td>180</td><td>129</td><td>180</td><td>Submission of Information Disclosure Sheet</td><td></td></tr> <tr><td>581</td><td>40</td><td>581</td><td>40</td><td>Recording each patent assignment per property (times number of properties)</td><td></td></tr> <tr><td>146</td><td>710</td><td>246</td><td>355</td><td>Filing a submission after final rejection (37 CFR § 1.129(a))</td><td></td></tr> <tr><td>149</td><td>710</td><td>249</td><td>355</td><td>For each additional invention to be examined (37 CFR § 1.129(b))</td><td></td></tr> <tr><td>178</td><td>710</td><td>279</td><td>355</td><td>Request for Continued Examination (RCE)</td><td></td></tr> <tr><td>169</td><td>900</td><td>169</td><td>900</td><td>Request for expedited examination of a design application</td><td></td></tr> </tbody> </table>		Large Fee Code	Entity Fee (\$)	Small Fee Code	Entity Fee (\$)	Fee Description	Fee Paid	105	130	205	65	Surcharge - late filing fee or oath	130	127	50	227	25	Surcharge - late provisional filing fee or cover sheet		139	130	139	130	Non-English specification		147	2,520	147	2,520	For filing a request for reexamination		112	920*	112	920*	Requesting publication of SIR prior to Examiner action		113	1,840*	113	1,840*	Requesting publication of SIR after Examiner action		115	110	215	55	Extension for reply within first month		116	390	216	195	Extension for reply within second month		117	660	217	445	Extension for reply within third month		118	1,190	218	695	Extension for reply within fourth month		128	1,890	228	945	Extension for reply within fifth month	1890	119	310	219	155	Notice of Appeal		120	310	220	155	Filing a brief in support of an appeal		121	270	221	135	Request for oral hearing		138	1,510	138	1,510	Petition to institute a public use proceeding		140	110	240	55	Petition to revive - unavoidable		141	1,240	241	620	Petition to revive - unintentional		142	1,240	242	620	Utility issue fee (or rehear)		143	440	243	220	Design issue fee		144	600	244	300	Plant issue fee		122	130	122	130	Petitions to the Commissioner		123	50	123	50	Petitions related to provisional applications		129	180	129	180	Submission of Information Disclosure Sheet		581	40	581	40	Recording each patent assignment per property (times number of properties)		146	710	246	355	Filing a submission after final rejection (37 CFR § 1.129(a))		149	710	249	355	For each additional invention to be examined (37 CFR § 1.129(b))		178	710	279	355	Request for Continued Examination (RCE)		169	900	169	900	Request for expedited examination of a design application	
Large Fee Code	Entity Fee (\$)	Small Fee Code	Entity Fee (\$)	Fee Description	Fee Paid																																																																																																																																																																												
105	130	205	65	Surcharge - late filing fee or oath	130																																																																																																																																																																												
127	50	227	25	Surcharge - late provisional filing fee or cover sheet																																																																																																																																																																													
139	130	139	130	Non-English specification																																																																																																																																																																													
147	2,520	147	2,520	For filing a request for reexamination																																																																																																																																																																													
112	920*	112	920*	Requesting publication of SIR prior to Examiner action																																																																																																																																																																													
113	1,840*	113	1,840*	Requesting publication of SIR after Examiner action																																																																																																																																																																													
115	110	215	55	Extension for reply within first month																																																																																																																																																																													
116	390	216	195	Extension for reply within second month																																																																																																																																																																													
117	660	217	445	Extension for reply within third month																																																																																																																																																																													
118	1,190	218	695	Extension for reply within fourth month																																																																																																																																																																													
128	1,890	228	945	Extension for reply within fifth month	1890																																																																																																																																																																												
119	310	219	155	Notice of Appeal																																																																																																																																																																													
120	310	220	155	Filing a brief in support of an appeal																																																																																																																																																																													
121	270	221	135	Request for oral hearing																																																																																																																																																																													
138	1,510	138	1,510	Petition to institute a public use proceeding																																																																																																																																																																													
140	110	240	55	Petition to revive - unavoidable																																																																																																																																																																													
141	1,240	241	620	Petition to revive - unintentional																																																																																																																																																																													
142	1,240	242	620	Utility issue fee (or rehear)																																																																																																																																																																													
143	440	243	220	Design issue fee																																																																																																																																																																													
144	600	244	300	Plant issue fee																																																																																																																																																																													
122	130	122	130	Petitions to the Commissioner																																																																																																																																																																													
123	50	123	50	Petitions related to provisional applications																																																																																																																																																																													
129	180	129	180	Submission of Information Disclosure Sheet																																																																																																																																																																													
581	40	581	40	Recording each patent assignment per property (times number of properties)																																																																																																																																																																													
146	710	246	355	Filing a submission after final rejection (37 CFR § 1.129(a))																																																																																																																																																																													
149	710	249	355	For each additional invention to be examined (37 CFR § 1.129(b))																																																																																																																																																																													
178	710	279	355	Request for Continued Examination (RCE)																																																																																																																																																																													
169	900	169	900	Request for expedited examination of a design application																																																																																																																																																																													
2. EXTRA CLAIM FEES Total Claims: 28 -20** = 8 Extra Claims X \$18 = \$144 Independent Claims: 8 -3** = 3 X \$84 = \$252 Multiple Dependent: X =		FEE CALCULATION (continued) 1. BASIC FILING FEE <table border="1"> <thead> <tr> <th>Large Fee Code</th> <th>Entity Fee (\$)</th> <th>Small Fee Code</th> <th>Entity Fee (\$)</th> <th>Fee Description</th> <th>Fee Paid</th> </tr> </thead> <tbody> <tr><td>101</td><td>710</td><td>201</td><td>355</td><td>Utility filing fee</td><td>710</td></tr> <tr><td>106</td><td>320</td><td>206</td><td>160</td><td>Design filing fee</td><td></td></tr> <tr><td>107</td><td>490</td><td>207</td><td>245</td><td>Plant filing fee</td><td></td></tr> <tr><td>108</td><td>710</td><td>208</td><td>355</td><td>Reissue filing fee</td><td></td></tr> <tr><td>114</td><td>150</td><td>214</td><td>75</td><td>Provisional filing fee</td><td></td></tr> <tr><td colspan="5">SUBTOTAL (1)</td><td>\$740</td></tr> </tbody> </table>		Large Fee Code	Entity Fee (\$)	Small Fee Code	Entity Fee (\$)	Fee Description	Fee Paid	101	710	201	355	Utility filing fee	710	106	320	206	160	Design filing fee		107	490	207	245	Plant filing fee		108	710	208	355	Reissue filing fee		114	150	214	75	Provisional filing fee		SUBTOTAL (1)					\$740																																																																																																																																				
Large Fee Code	Entity Fee (\$)	Small Fee Code	Entity Fee (\$)	Fee Description	Fee Paid																																																																																																																																																																												
101	710	201	355	Utility filing fee	710																																																																																																																																																																												
106	320	206	160	Design filing fee																																																																																																																																																																													
107	490	207	245	Plant filing fee																																																																																																																																																																													
108	710	208	355	Reissue filing fee																																																																																																																																																																													
114	150	214	75	Provisional filing fee																																																																																																																																																																													
SUBTOTAL (1)					\$740																																																																																																																																																																												
2. EXTRA CLAIM FEES <table border="1"> <thead> <tr> <th>Large Fee Code</th> <th>Entity Fee (\$)</th> <th>Small Fee Code</th> <th>Entity Fee (\$)</th> <th>Fee Description</th> <th>Fee Paid</th> </tr> </thead> <tbody> <tr><td>103</td><td>18</td><td>203</td><td>9</td><td>Claims in excess of 20</td><td></td></tr> <tr><td>102</td><td>80</td><td>202</td><td>40</td><td>Independent claims in excess of 3</td><td></td></tr> <tr><td>104</td><td>270</td><td>204</td><td>135</td><td>Multiple dependent claim, if not paid</td><td></td></tr> <tr><td>109</td><td>80</td><td>209</td><td>40</td><td>** Reissue independent claims over original patent</td><td></td></tr> <tr><td>110</td><td>18</td><td>210</td><td>9</td><td>** Reissue claims in excess of 20 and over original patent</td><td></td></tr> <tr><td colspan="5">SUBTOTAL (2)</td><td>\$788</td></tr> </tbody> </table>		Large Fee Code	Entity Fee (\$)	Small Fee Code	Entity Fee (\$)	Fee Description	Fee Paid	103	18	203	9	Claims in excess of 20		102	80	202	40	Independent claims in excess of 3		104	270	204	135	Multiple dependent claim, if not paid		109	80	209	40	** Reissue independent claims over original patent		110	18	210	9	** Reissue claims in excess of 20 and over original patent		SUBTOTAL (2)					\$788	Other fee (specify): The Commissioner is authorized to charge any additional fees to the above noted Deposit Account. *Reduced by Basic Filing Fee Paid SUBTOTAL (3) \$2090																																																																																																																																					
Large Fee Code	Entity Fee (\$)	Small Fee Code	Entity Fee (\$)	Fee Description	Fee Paid																																																																																																																																																																												
103	18	203	9	Claims in excess of 20																																																																																																																																																																													
102	80	202	40	Independent claims in excess of 3																																																																																																																																																																													
104	270	204	135	Multiple dependent claim, if not paid																																																																																																																																																																													
109	80	209	40	** Reissue independent claims over original patent																																																																																																																																																																													
110	18	210	9	** Reissue claims in excess of 20 and over original patent																																																																																																																																																																													
SUBTOTAL (2)					\$788																																																																																																																																																																												

SUBMITTED BY		Complete if applicable			
Name (Print/Type)	Gerald T. Gray	Registration No. (Attorney/Agent)	41,787	Telephone	825-472-5000
Signature	<i>Gerald T. Gray</i>	Date	10/09/01		

WARNING: Information on this form may become public. Credit card information should not be included on this form. Provide credit card information and authorization on PTO-2038.

Burden Hour Statement: This form is estimated to take 0.2 hours to complete. Time will vary depending upon the needs of the individual case. Any comments on the amount of time you are required to complete this form should be sent to the Chief Information Officer, Patent and Trademark Office, Washington, DC 20231. DO NOT SEND TO: Assistant Commissioner for Patents, Washington, DC 20231. V

Received from <9254728893> at 4/9/02 5:12:19 PM [Eastern Daylight Time]



525

Attorney Docket No.: 20046H-000100US

308 COPY OF PAPERS
ORIGINALLY FILED
01/22/02

DECLARATION AND POWER OF ATTORNEY

As a below named inventor, I declare that:

My residence, post office address and citizenship are as stated below next to my name; I believe I am the original, first and sole inventor (if only one name is listed below) or an original, first and joint inventor (if plural inventors are named below) of the subject matter which is claimed and for which a patent is sought on the invention entitled: **METHOD AND DEVICE FOR AUTOMATIC VISUAL PERCEPTION** the specification of which is attached hereto or was filed on 02/23/2002 as Application No. 097492136 and was amended on (if applicable).

I have reviewed and understand the contents of the above identified specification, including the claims, as amended by any amendment referred to above. I acknowledge the duty to disclose information which is material to patentability as defined in Title 37, Code of Federal Regulations, Section 1.56. I claim foreign priority benefits under Title 35, United States Code, Section 119 of any foreign application(s) for patent or inventor's certificate listed below and have also identified below any foreign application for patent or inventor's certificate having a filing date before that of the application on which priority is claimed.

Prior Foreign Application(s)

Country	Application No.	Date of Filing	Priority Claimed Under 35 USC 119
France	00 02355	02/24/00	

hereby claim the benefit under Title 35, United States Code § 119(e) of any United States provisional application(s) listed below:

Application No.	Filing Date

I claim the benefit under Title 35, United States Code, Section 120 of any United States application(s) listed below and, insofar as the subject matter of each of the claims of this application is not disclosed in the prior United States application in the manner provided by the first paragraph of Title 35, United States Code, Section 112, I acknowledge the duty to disclose material information as defined in Title 37, Code of Federal Regulations, Section 1.56 which occurred between the filing date of the prior application and the national or PCT international filing date of this application:

Application No.	Date of Filing	Status

POWER OF ATTORNEY: As a named inventor, I hereby appoint the following attorney(s) and/or agent(s) to prosecute this application and transact all business in the Patent and Trademark Office connected therewith.

Gerald T. Gray, Reg. No. 41,797
Babak S. Sani, Reg. No. 37,495

Send Correspondence to: Gerald T. Gray TOWNSEND and TOWNSEND and CREW LLP Two Embarcadero Center, 8 th Floor San Francisco, California 94111-3834	Direct Telephone Calls to: (Name, Reg. No., Telephone No.) Name: Gerald T. Gray Reg. No.: 41,797 Telephone: 925-472-5000
--	--

TSVP

Attorney Docket No.: 2004GH-000100US

Full Name of Inventor 1:	Last Name: PIRIM	First Name: PATRICK	Middle Name or Initial:	
Residence & Citizenship:	City: 75013 Paris	State/Foreign Country: France	Country of Citizenship: France	
Post Office Address:	Post Office Address: 56 Rue Patay	City: 75013 Paris	State/Country: France	Postal Code:

I further declare that all statements made herein of my own knowledge are true and that all statements made on information and belief are believed to be true; and further that these statements were made with the knowledge that willful false statements and the like so made are punishable by fine or imprisonment, or both, under Section 1001 of Title 18 of the United States Code, and that such willful false statements may jeopardize the validity of the application or any patent issuing thereon.

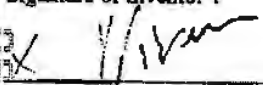
Signature of Inventor 1 
Patrick Pirim
Date 25-03-2001

SF 1183098 v1

RECEIVED

2002070-00426263

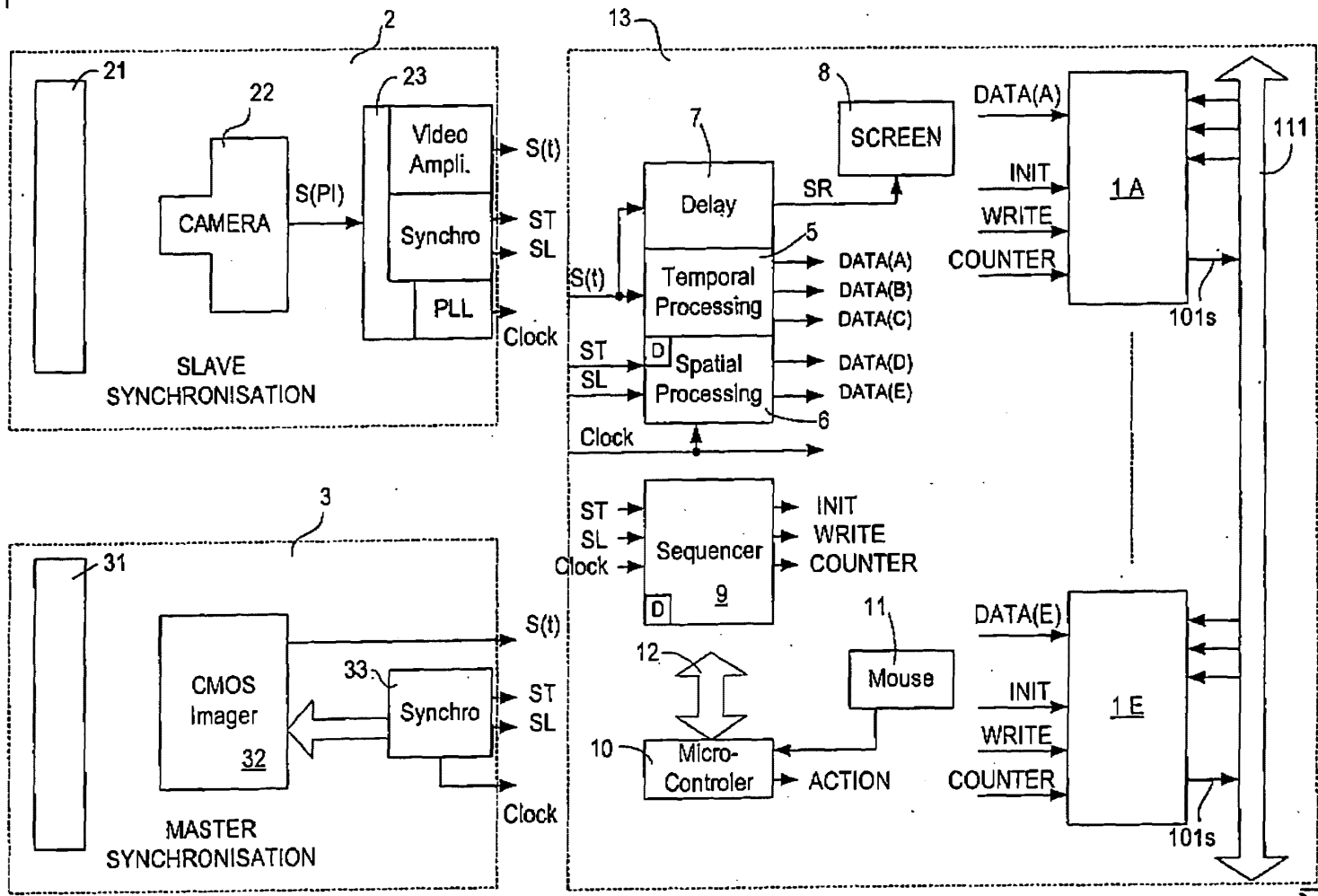

FIG. 1 PRIOR ART

202210 92547288

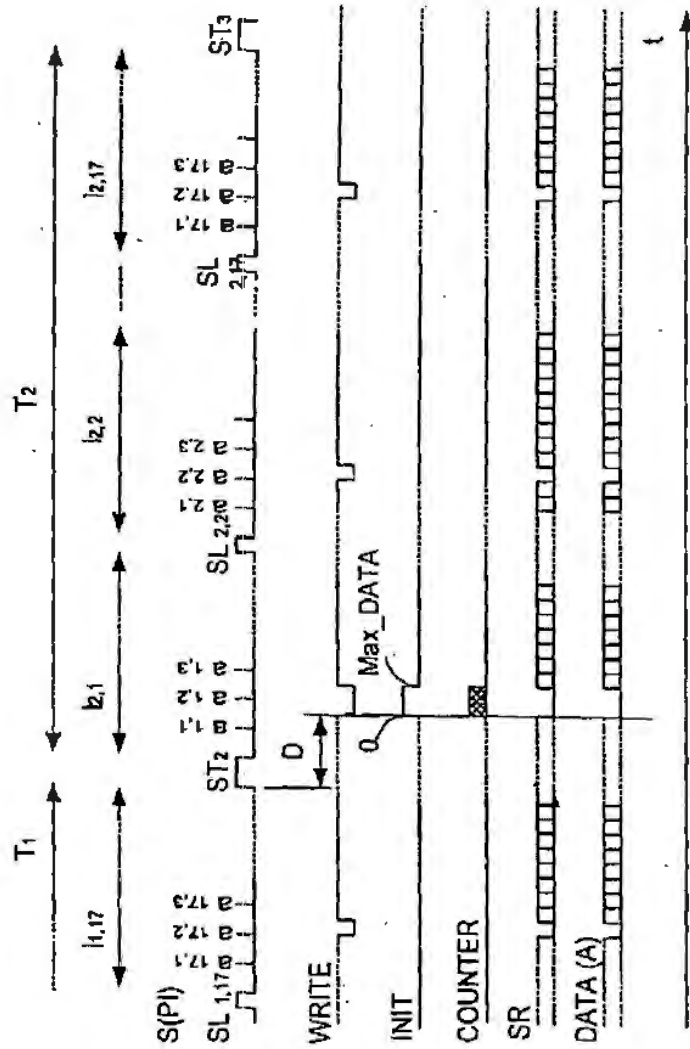

FIG. 2

20270-061260

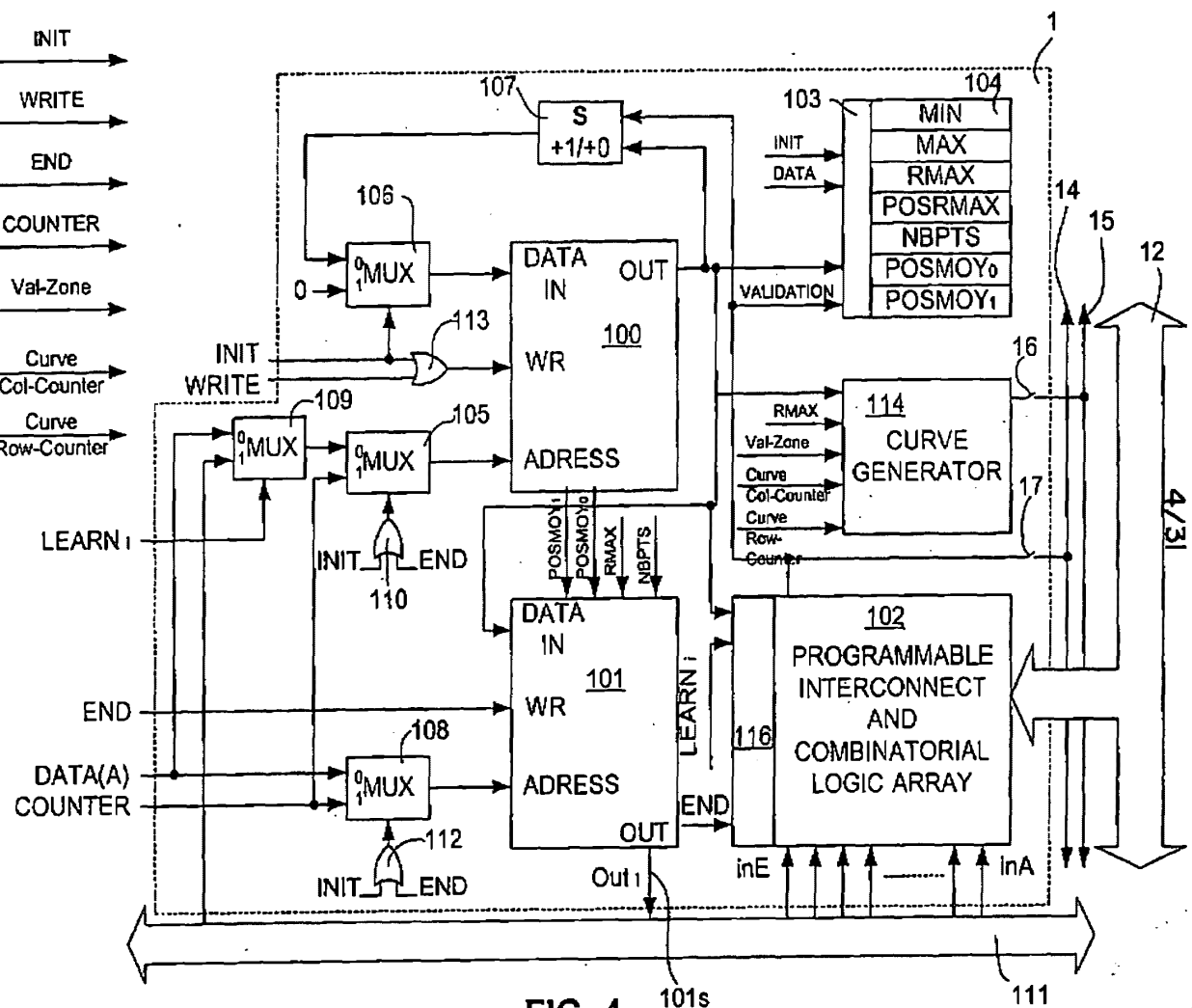

FIG. 4

5/31

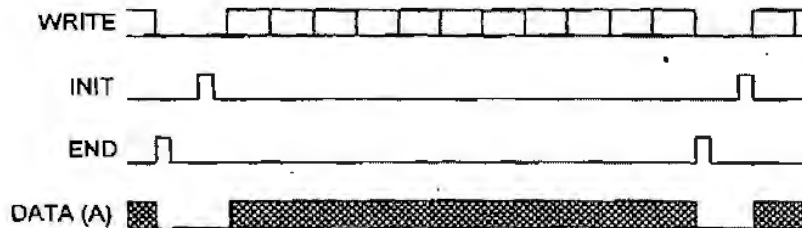

FIG. 5

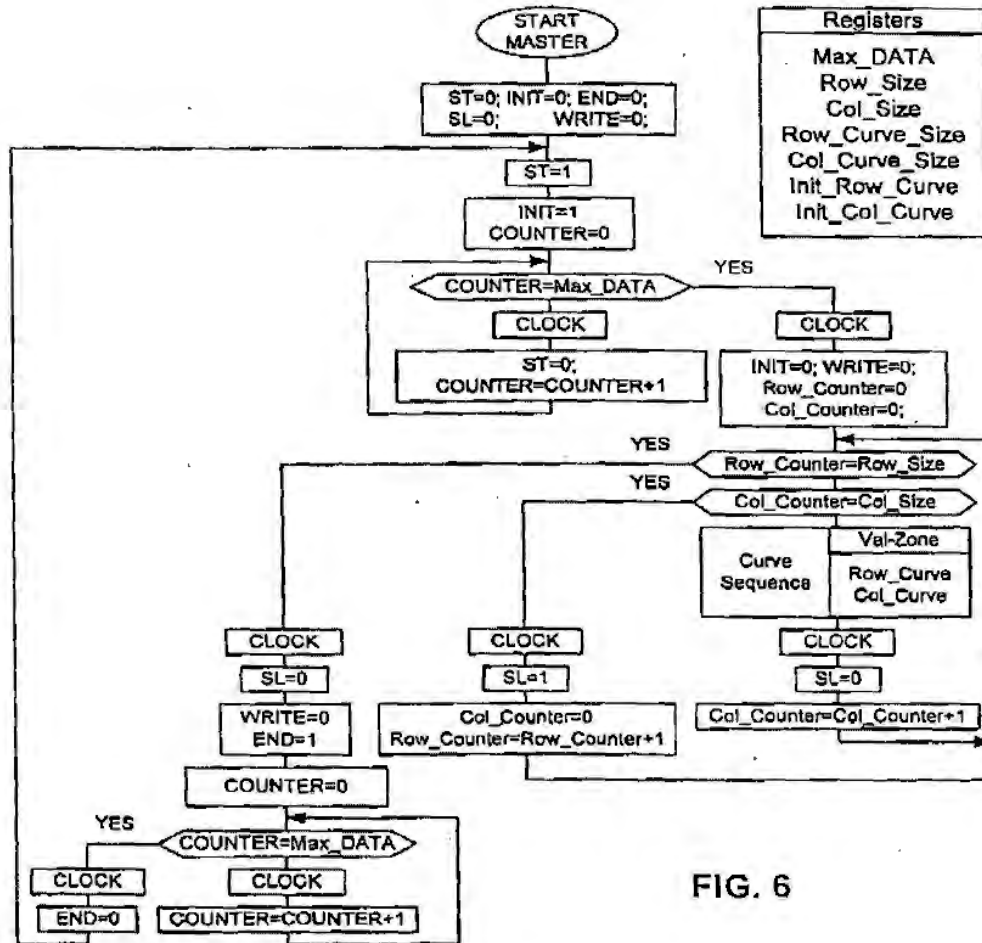

FIG. 6

20250709 09:25:50

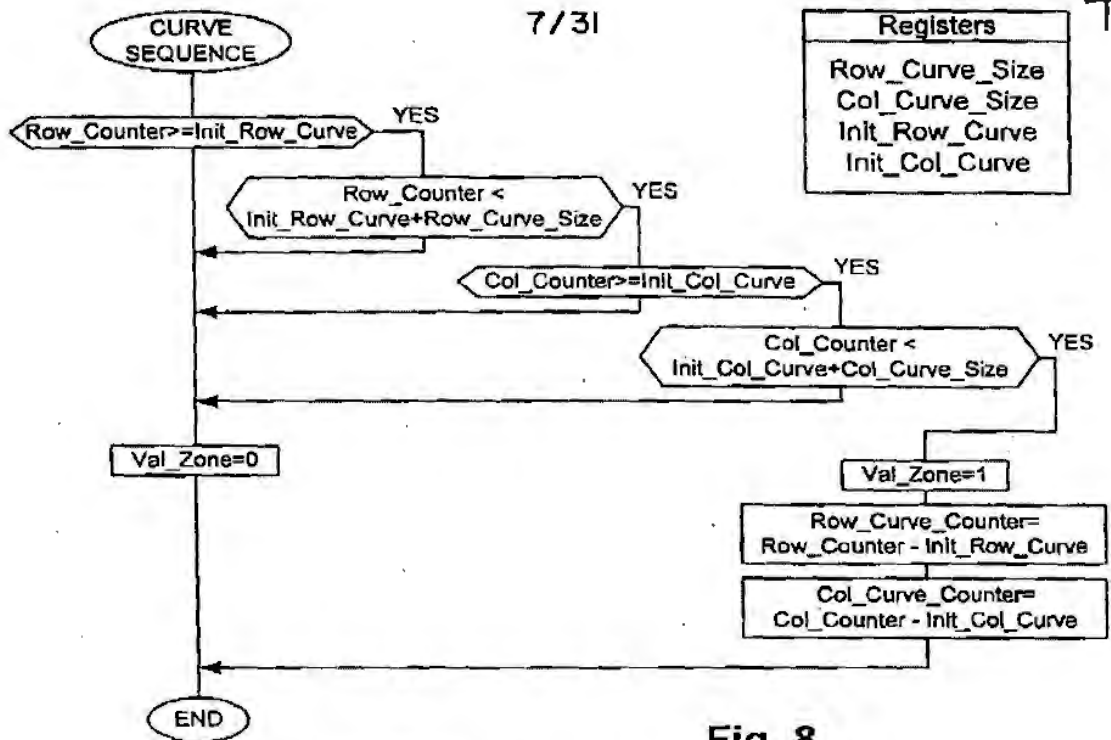

Fig. 8

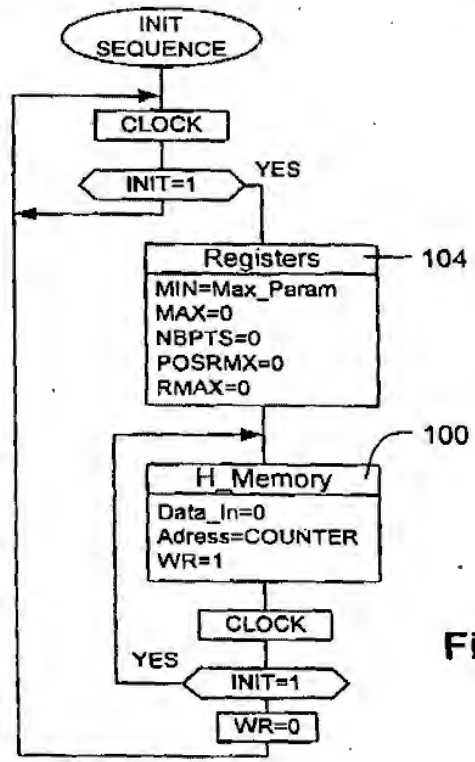

Fig. 9

20020408 09:24:30

8/31

00210" 92547288

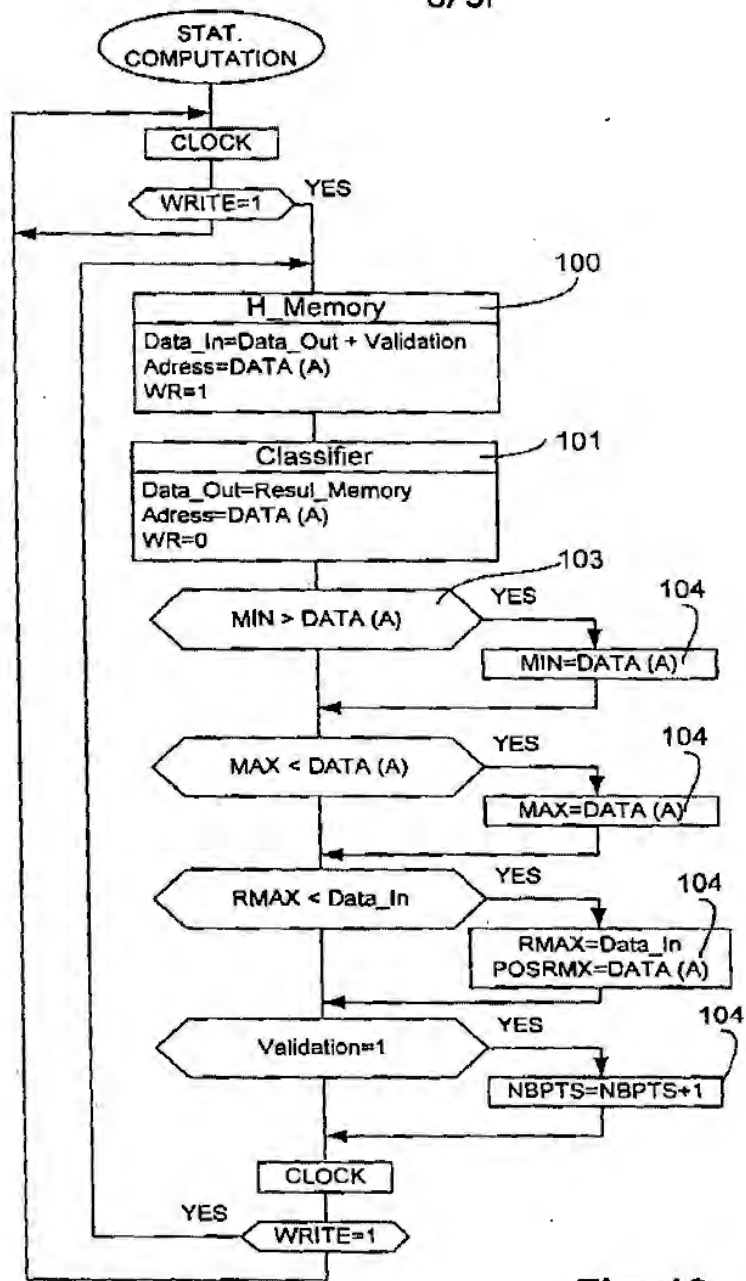

Fig. 10

9/31



2025472890

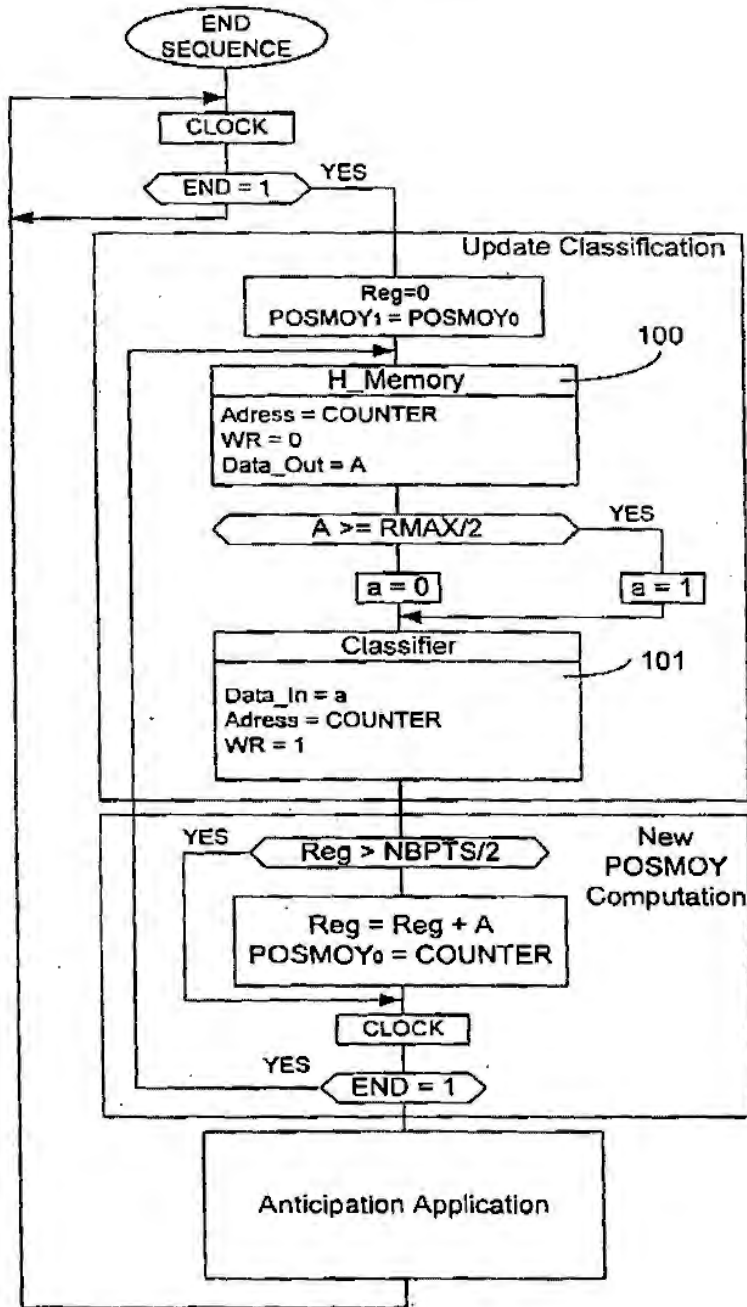

Fig. 11

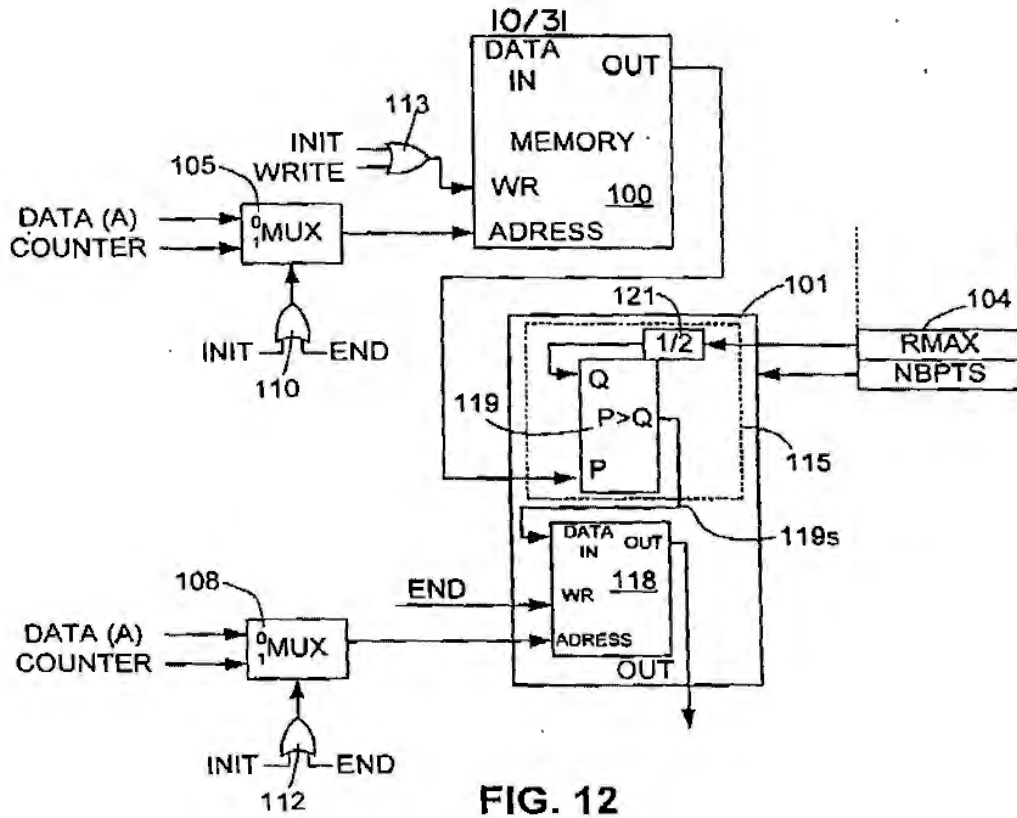

FIG. 12

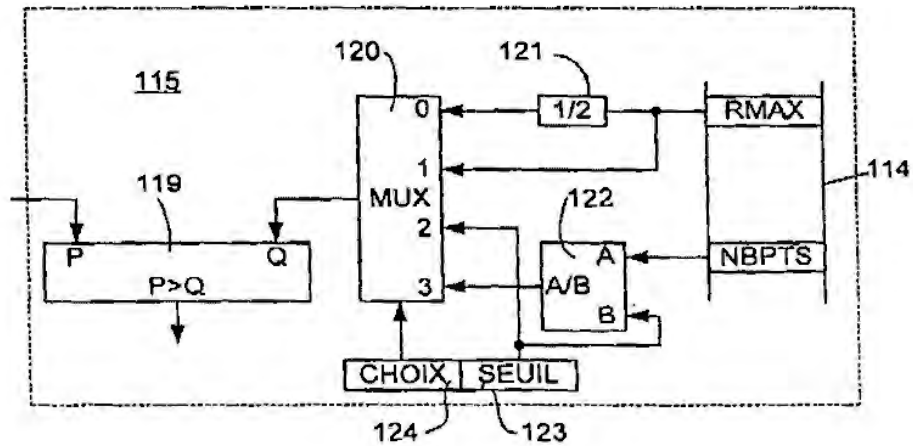

FIG. 13

11/31

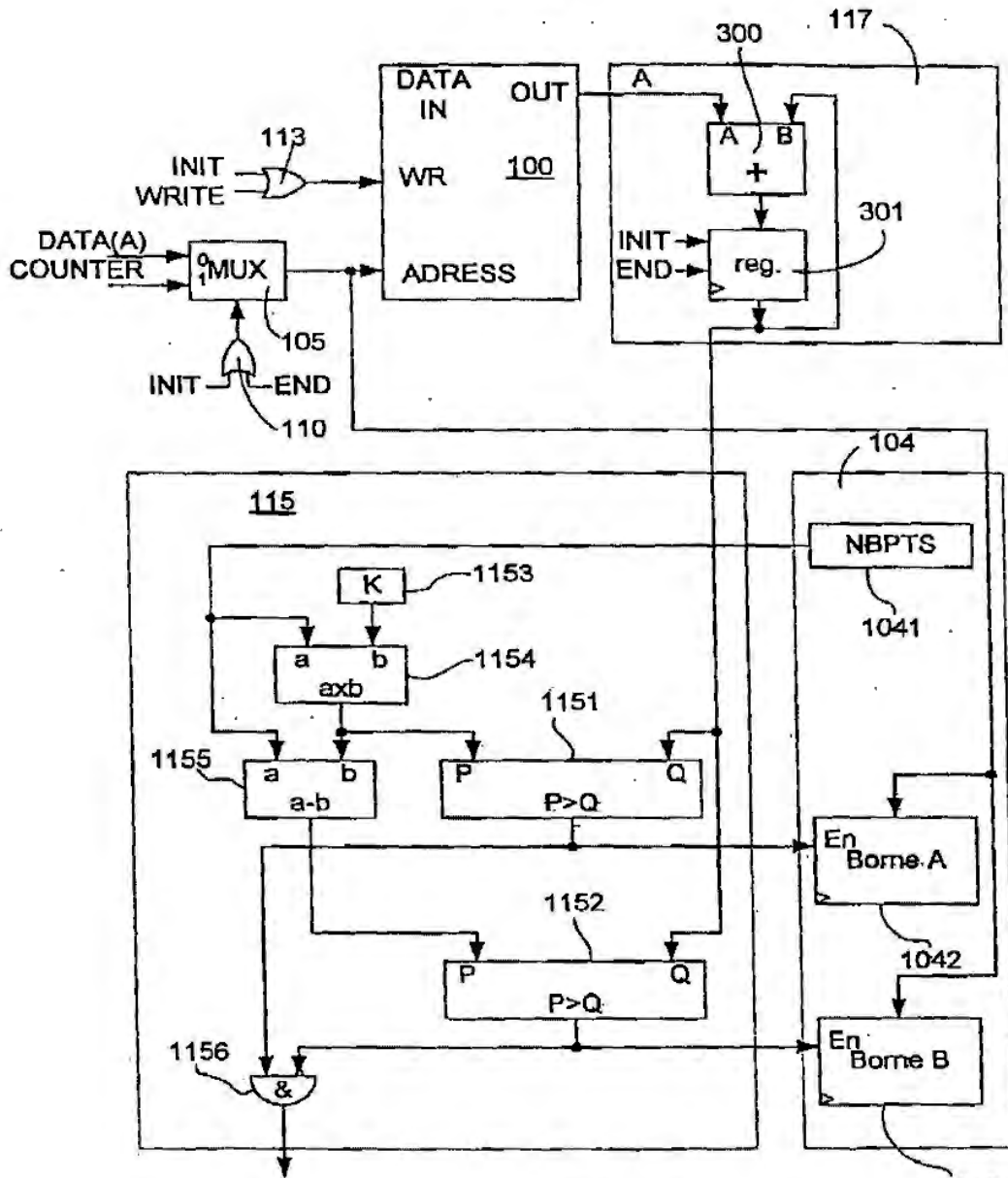

FIG. 13c

92547288



202270 95472893

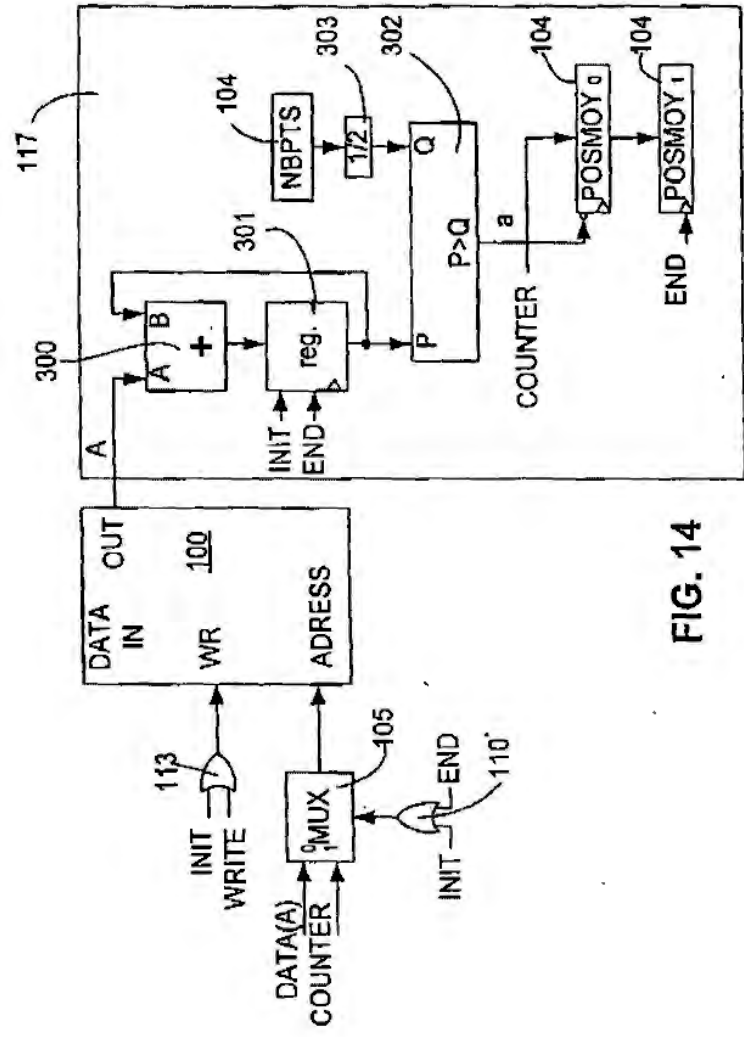

FIG. 14

09792436 54728893

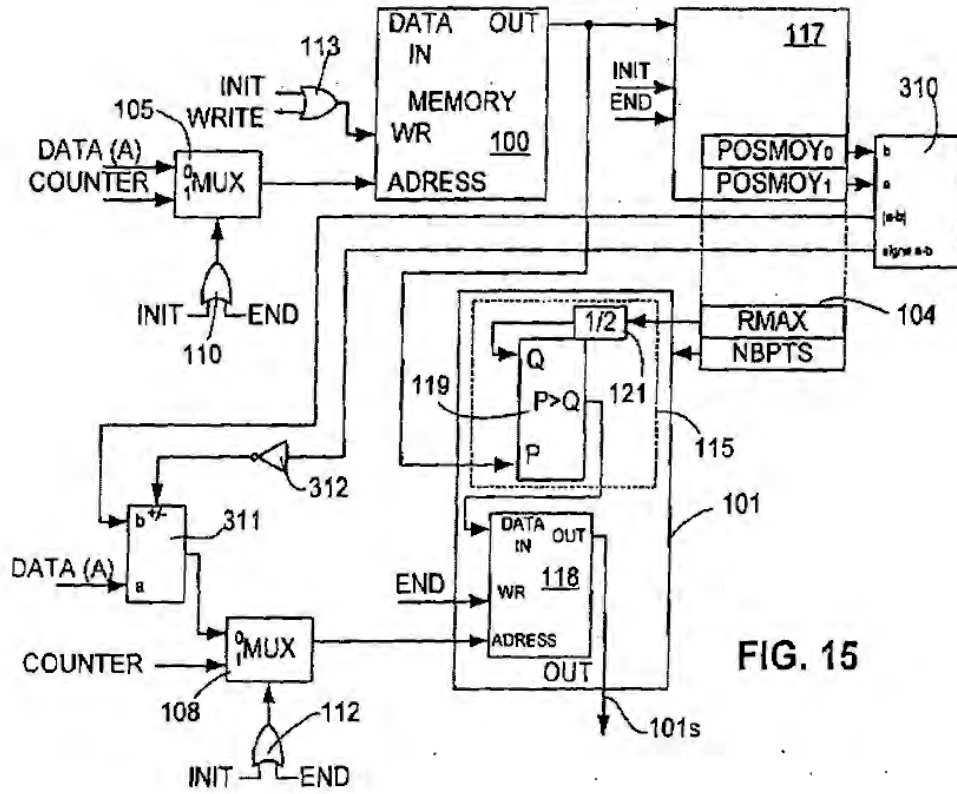

FIG. 15

13/31

002020 36426200

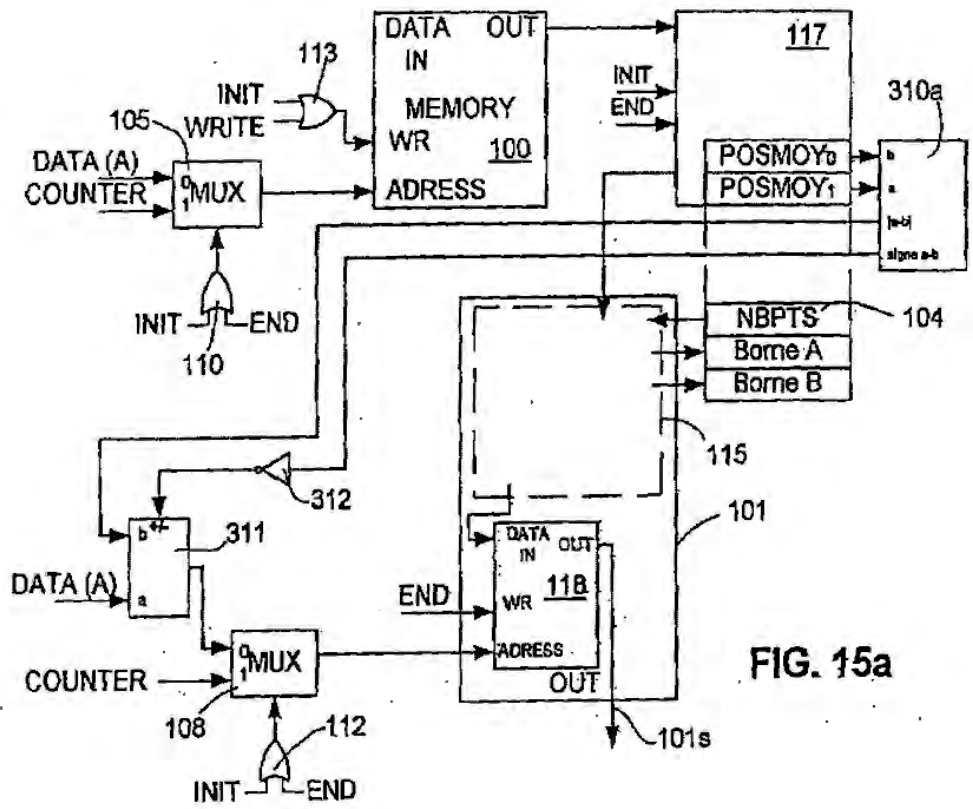

FIG. 15a

14/31

097992438 - 012202

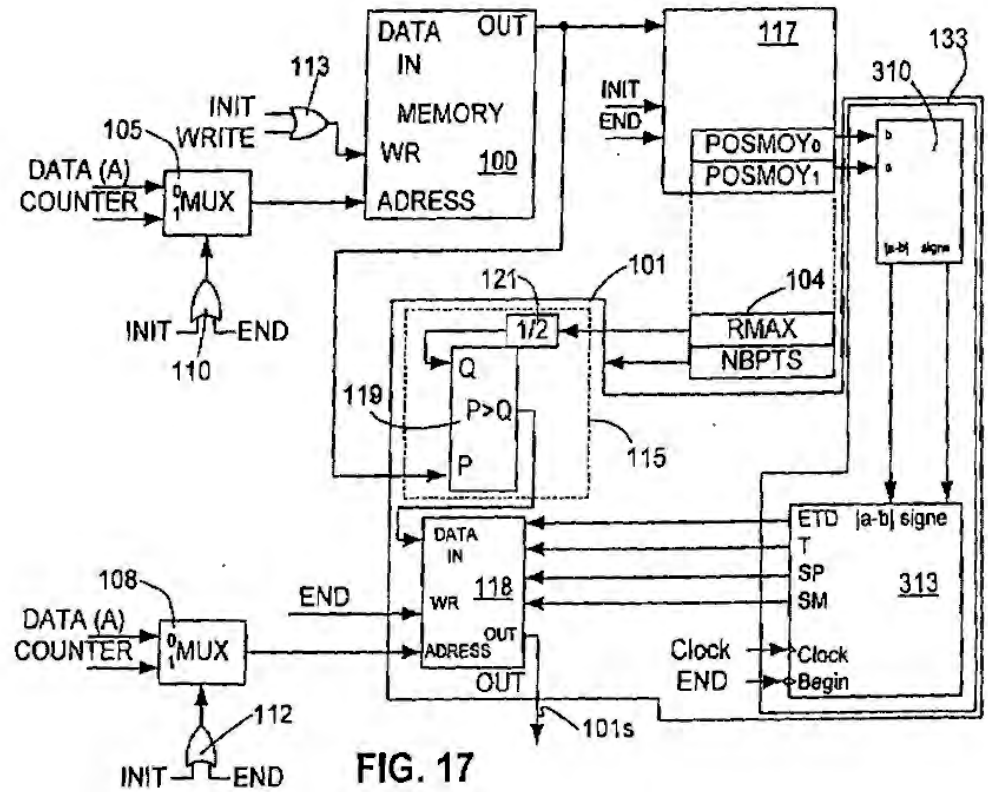

FIG. 17

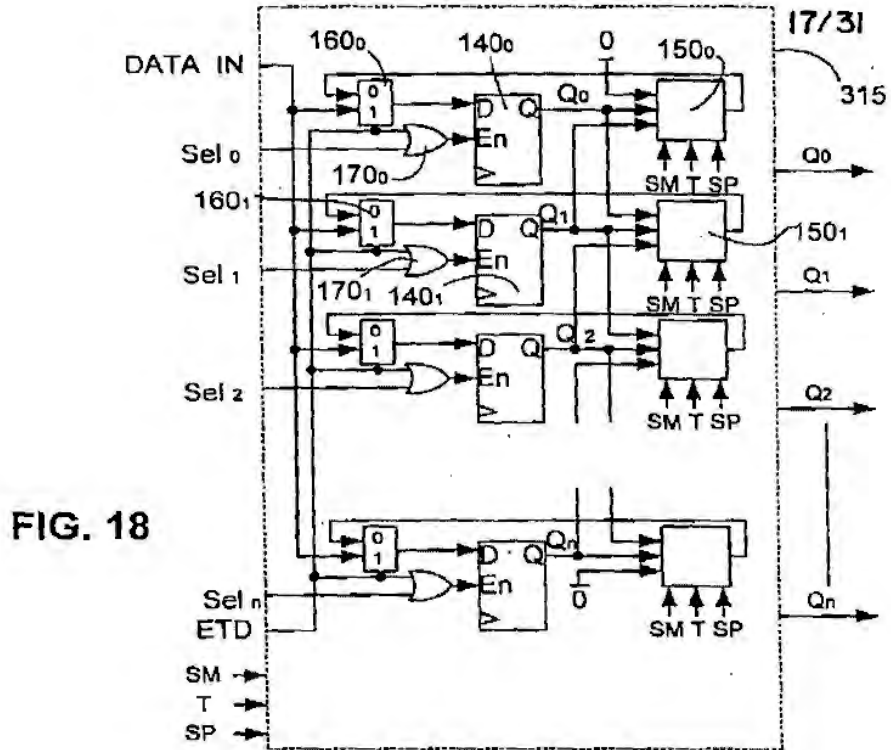

FIG. 18

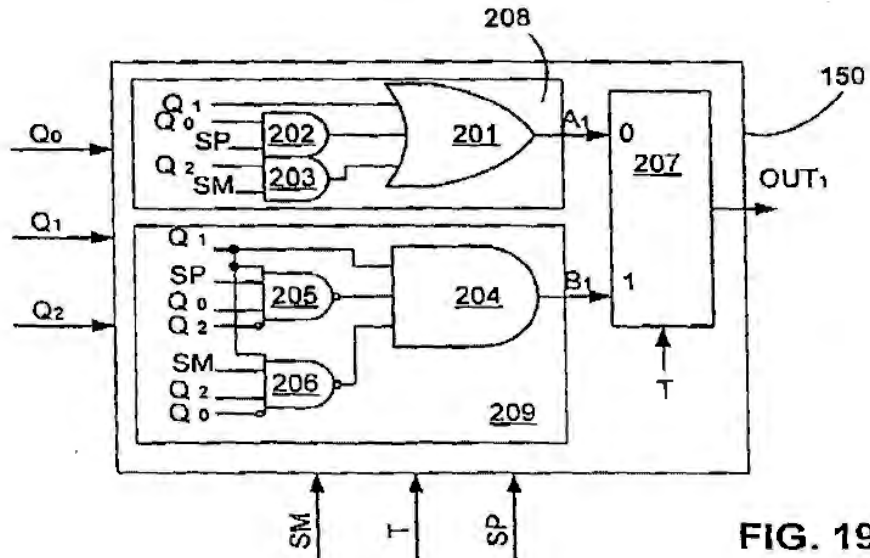

FIG. 19

18/31



04/09/2002 13:09 FAX 92547286

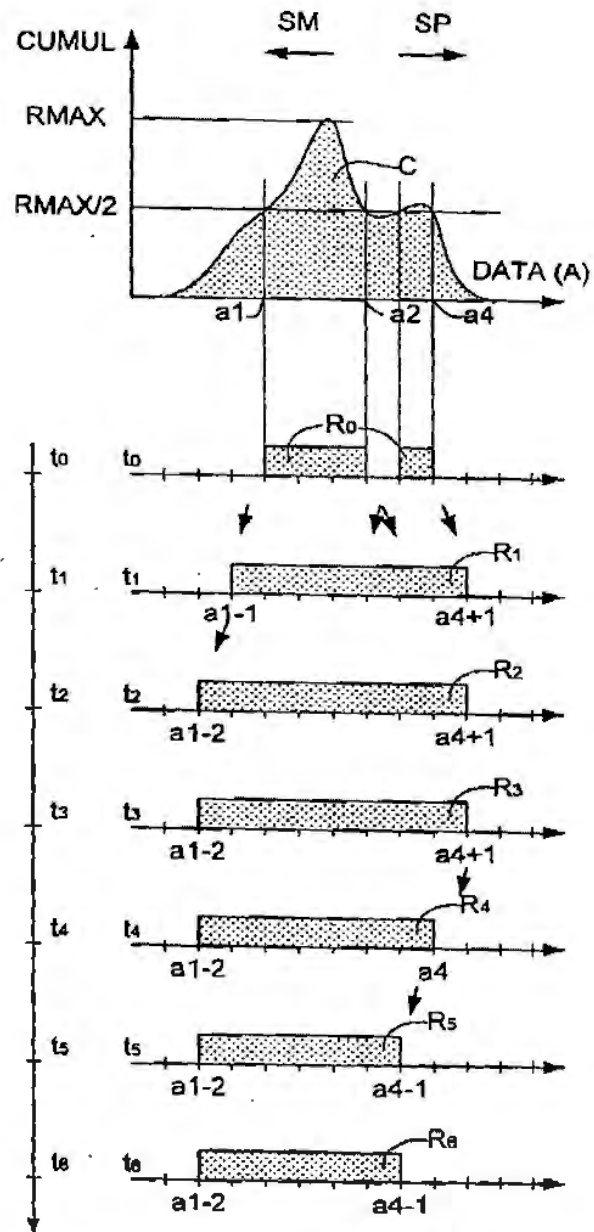
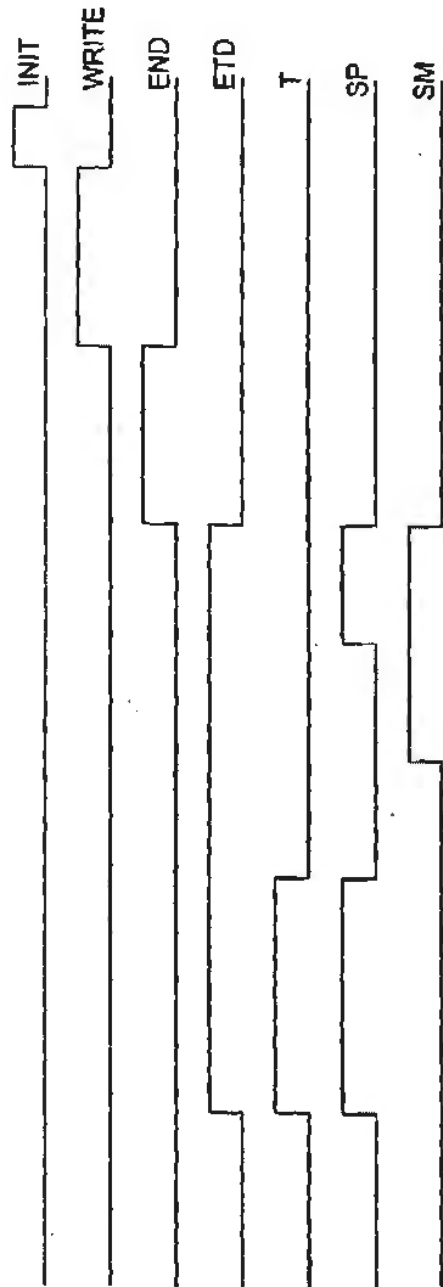

FIG. 20

19/31



0272436 0220

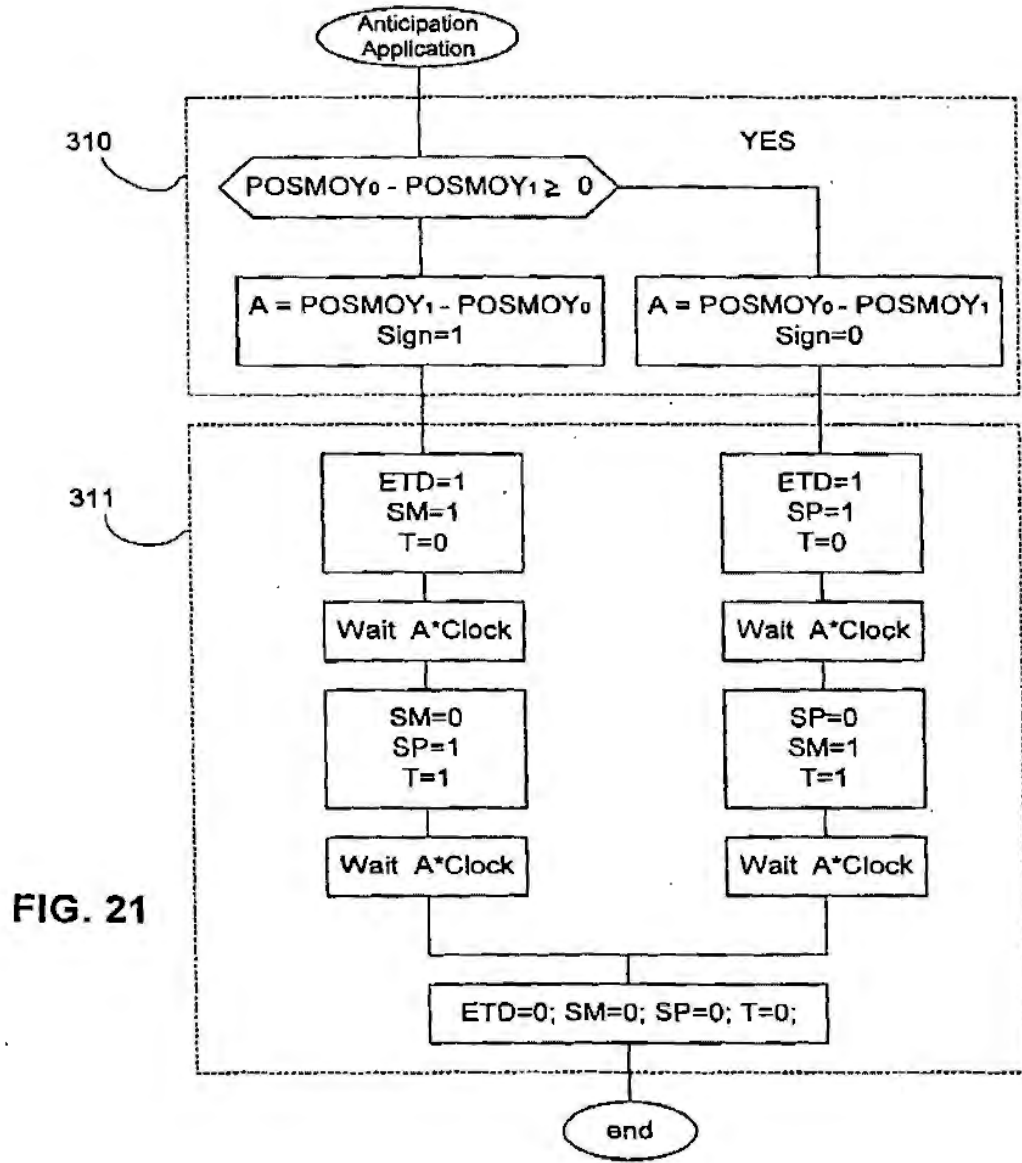
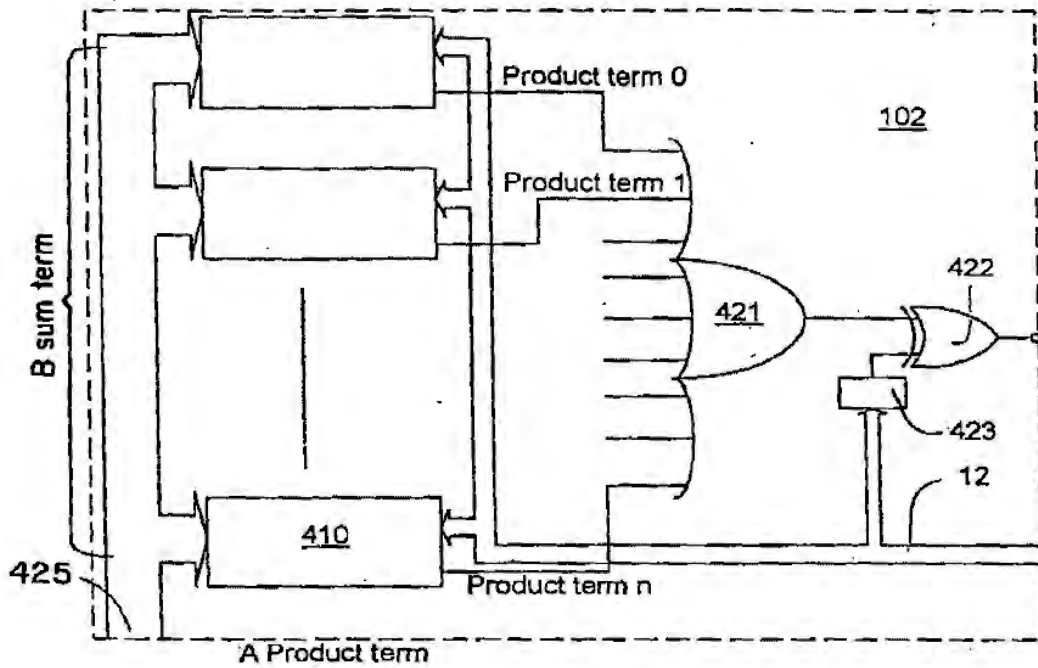

FIG. 21

20/31



A Product term

FIG 22

RECEIVED: 9/26/02

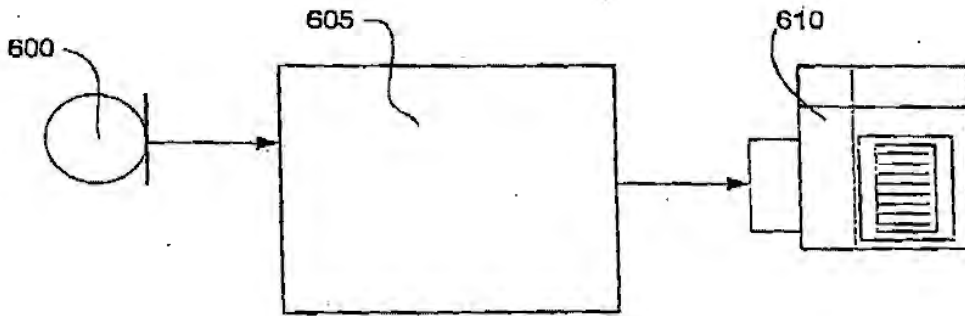

FIG. 39



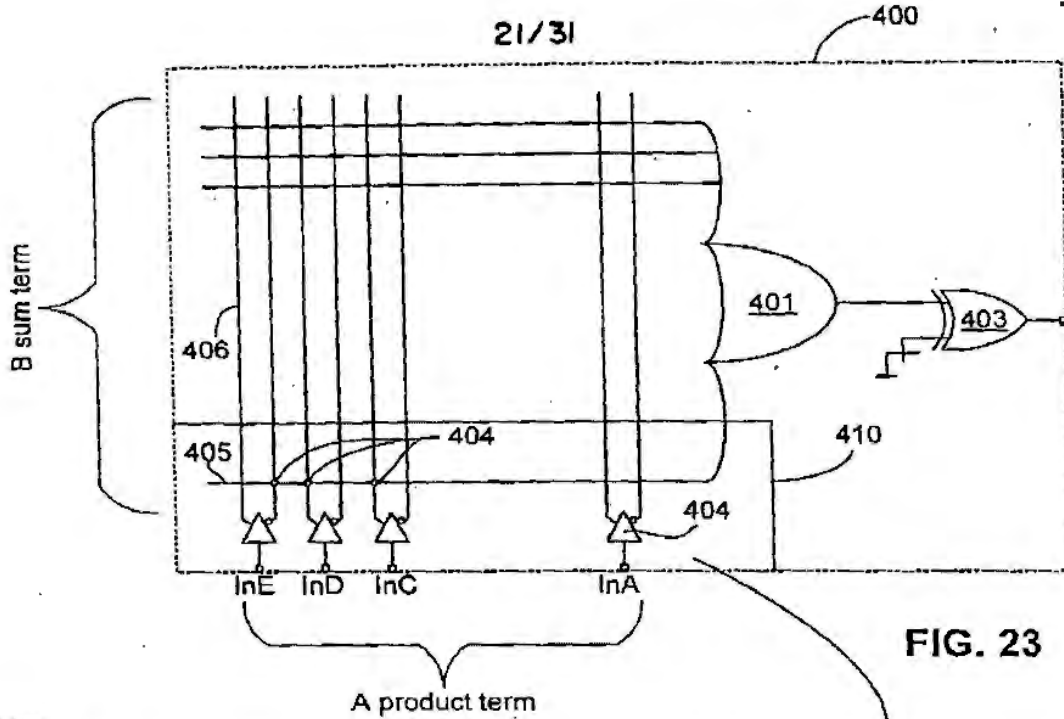

FIG. 23

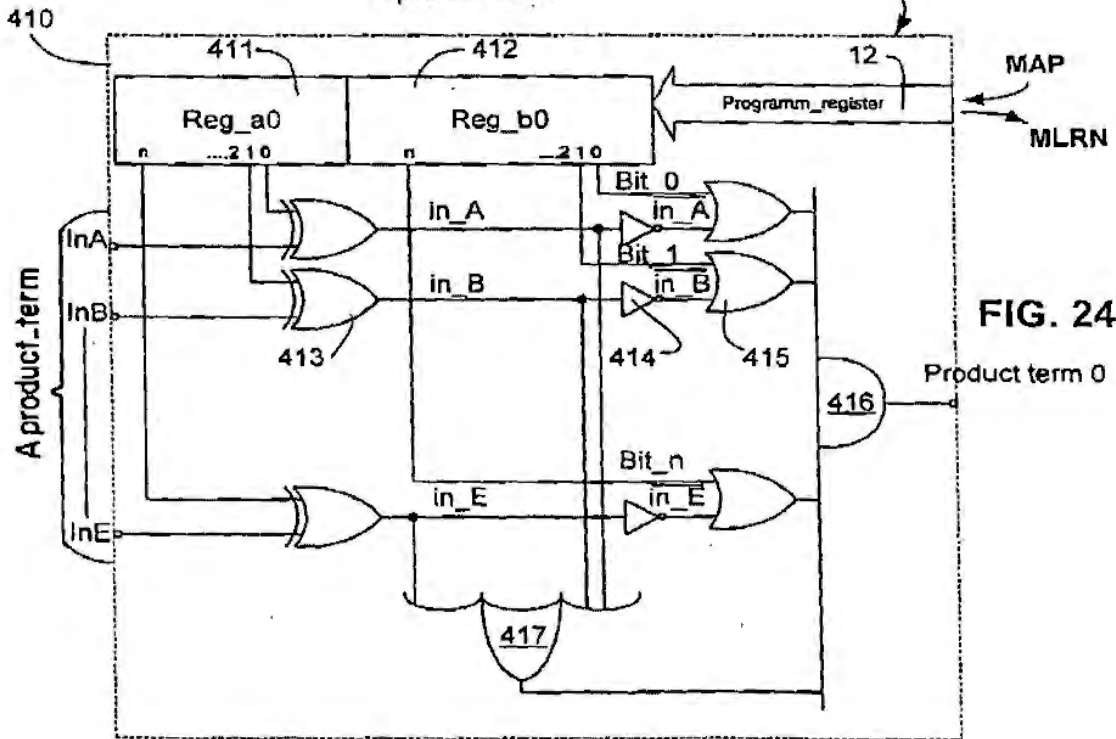

FIG. 24

0 2 7 9 2 1 4 3 6 . 0 1 4 2 2 0 2

Received from < 925472883 > at 4/9/02 5:17:19 PM [Eastern Daylight Time]

04/09/2002 13:10 FAX 925472883

TOWNSEND & TOWNSEND CREW

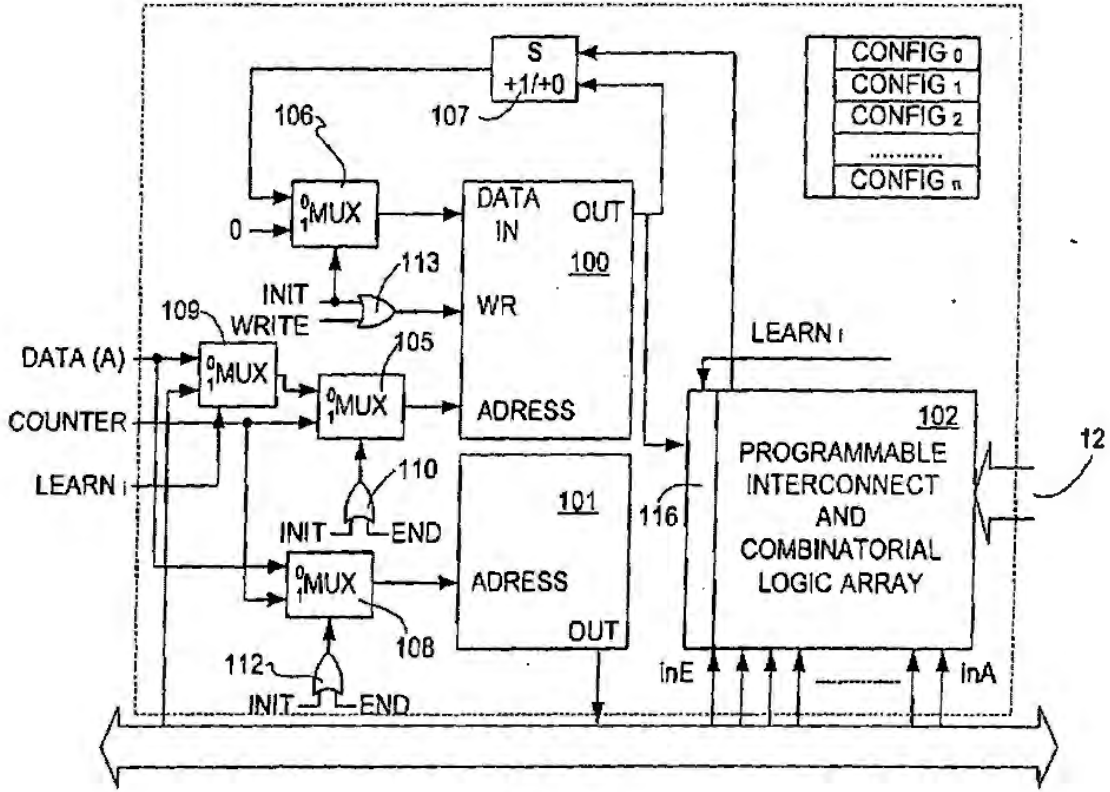

FIG. 25

22 / 31

20032

24/31

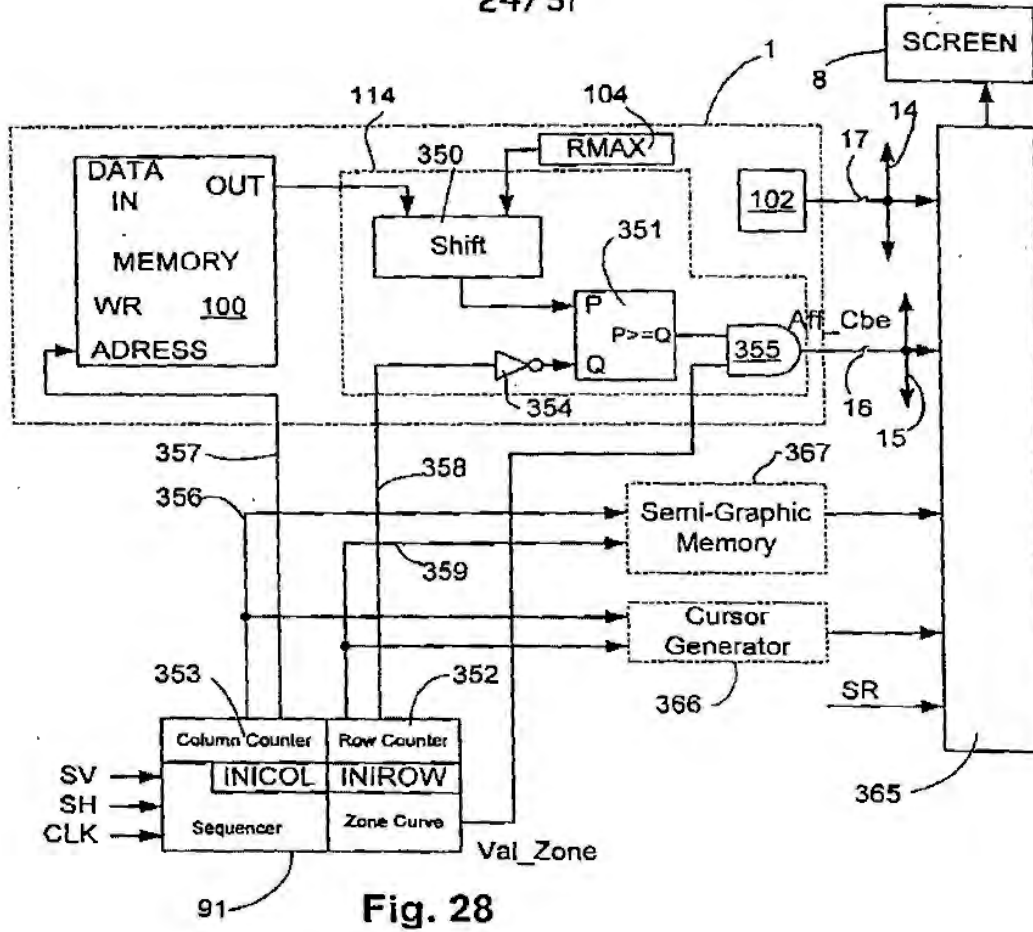

Fig. 28

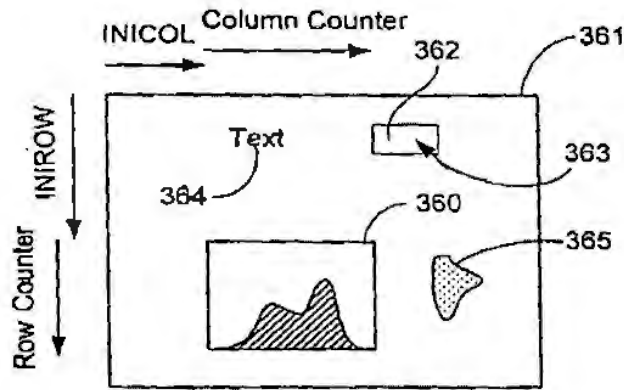
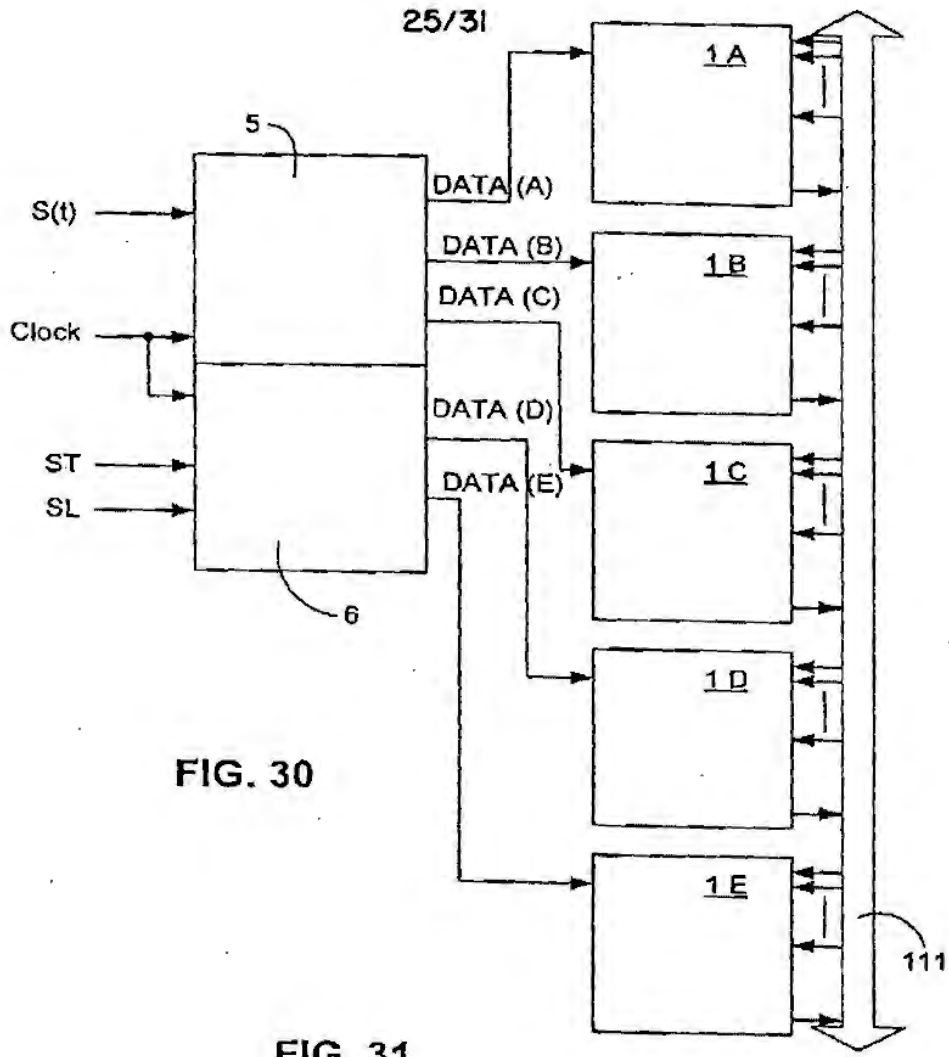

Fig. 29

RECEIVED



00924260

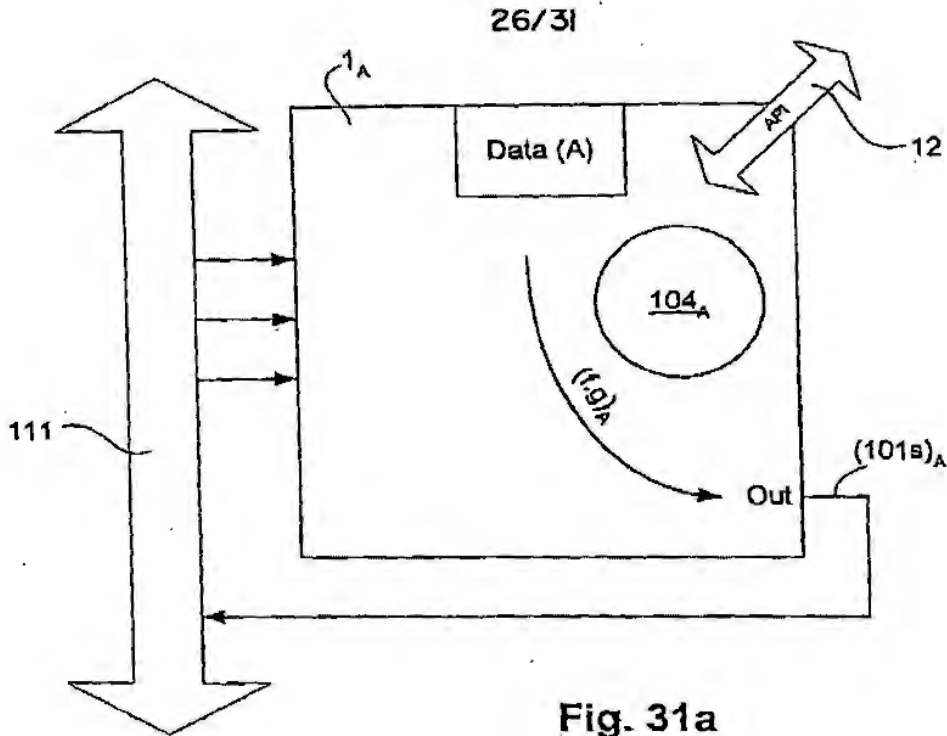

Fig. 31a

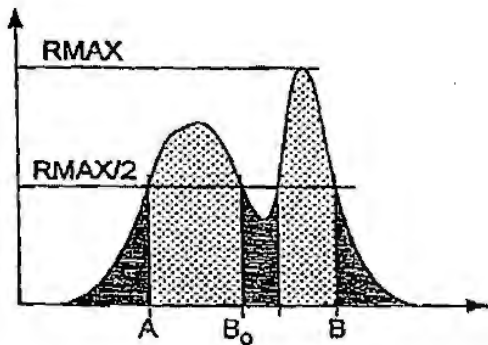

Fig 13a

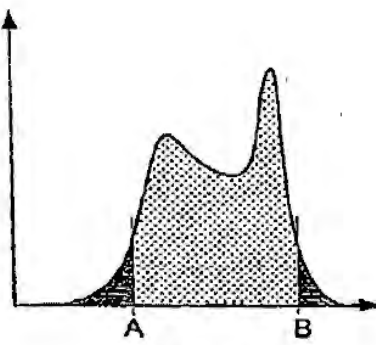

Fig 13b

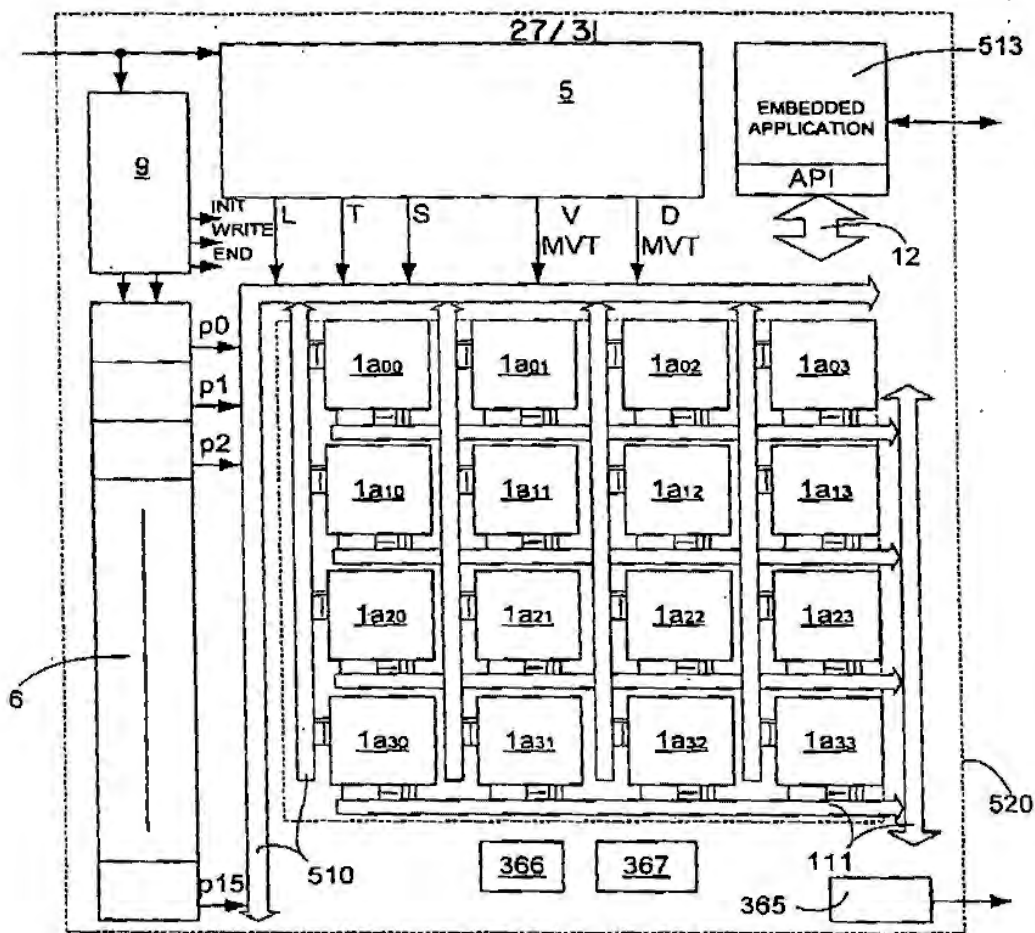

FIG. 32

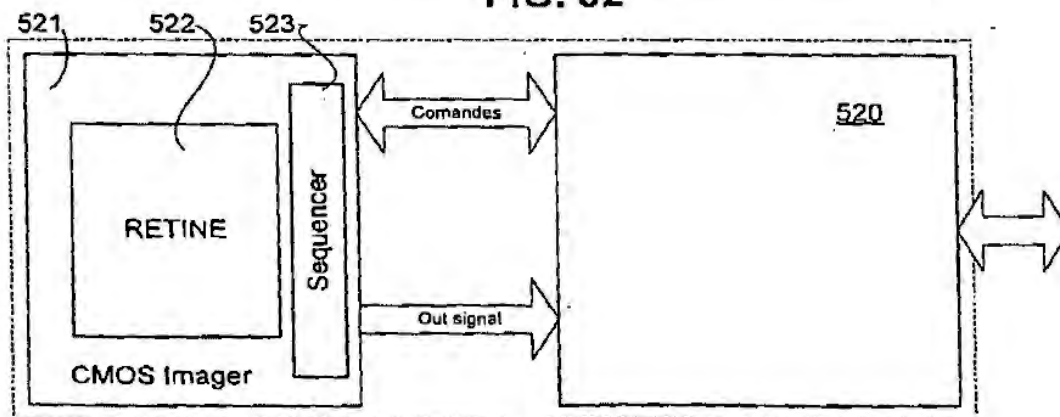

FIG. 33

28/31

202210 95426260

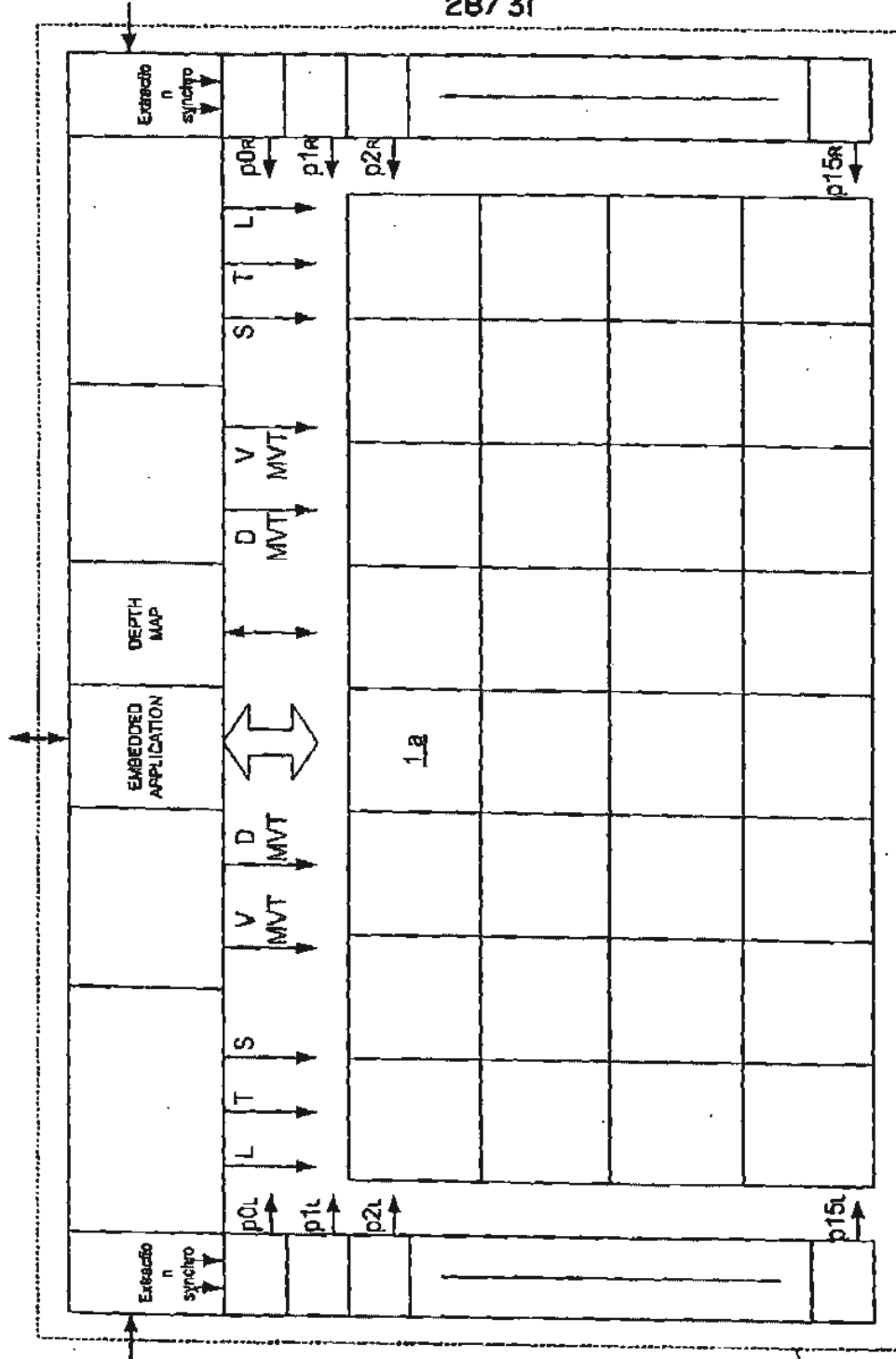

FIG. 34

530

202210 06125460

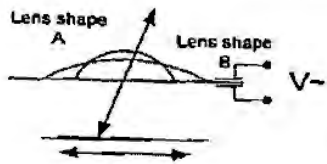
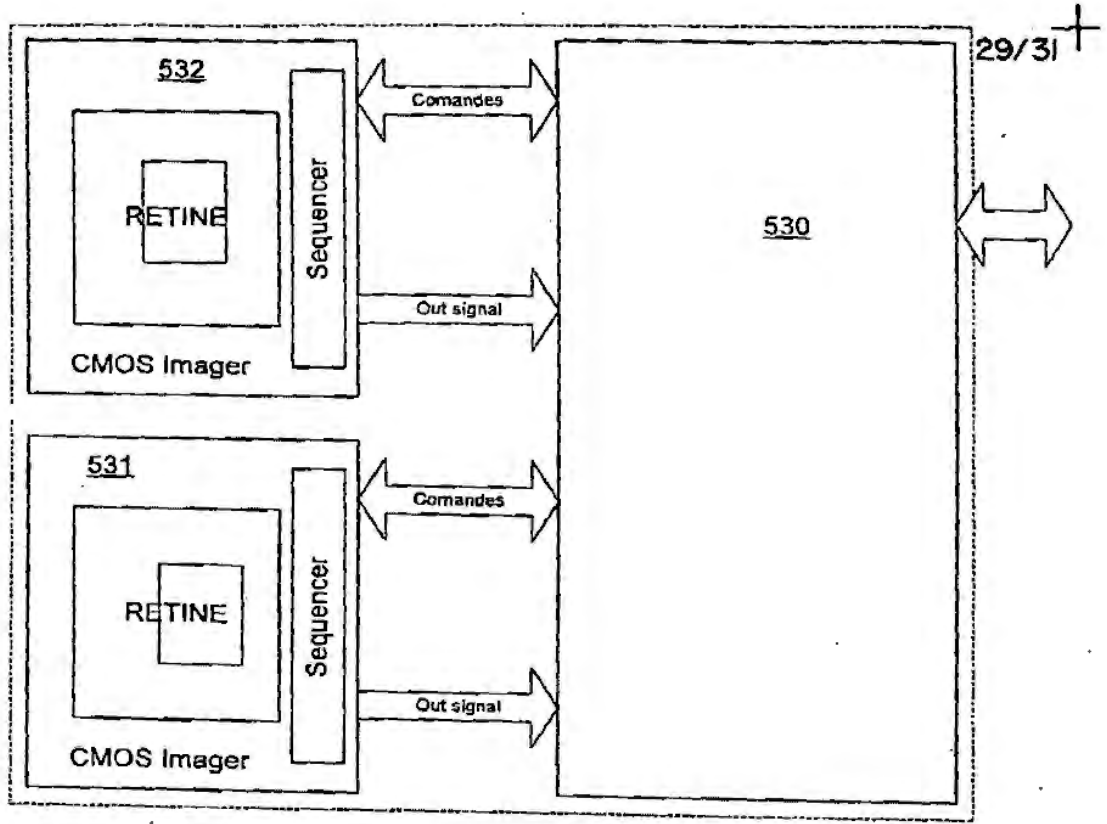

FIG. 36

FIG. 35

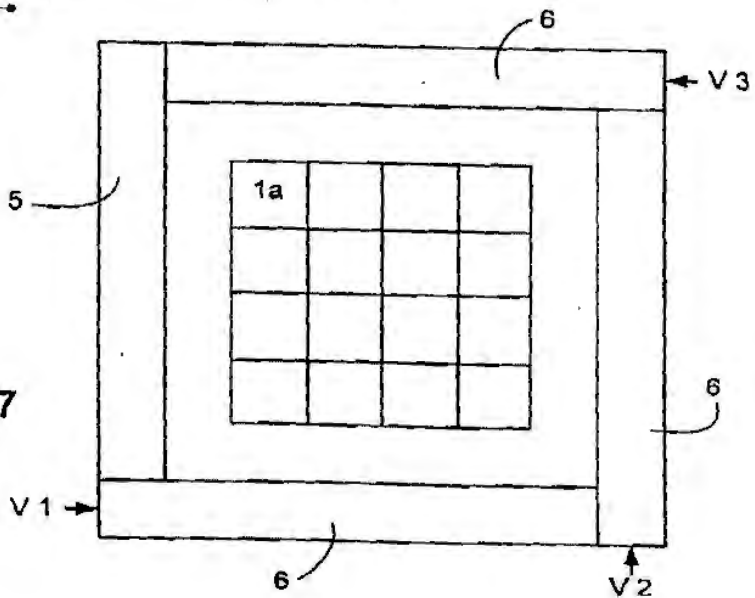

FIG. 37

30/31



20270 92547289

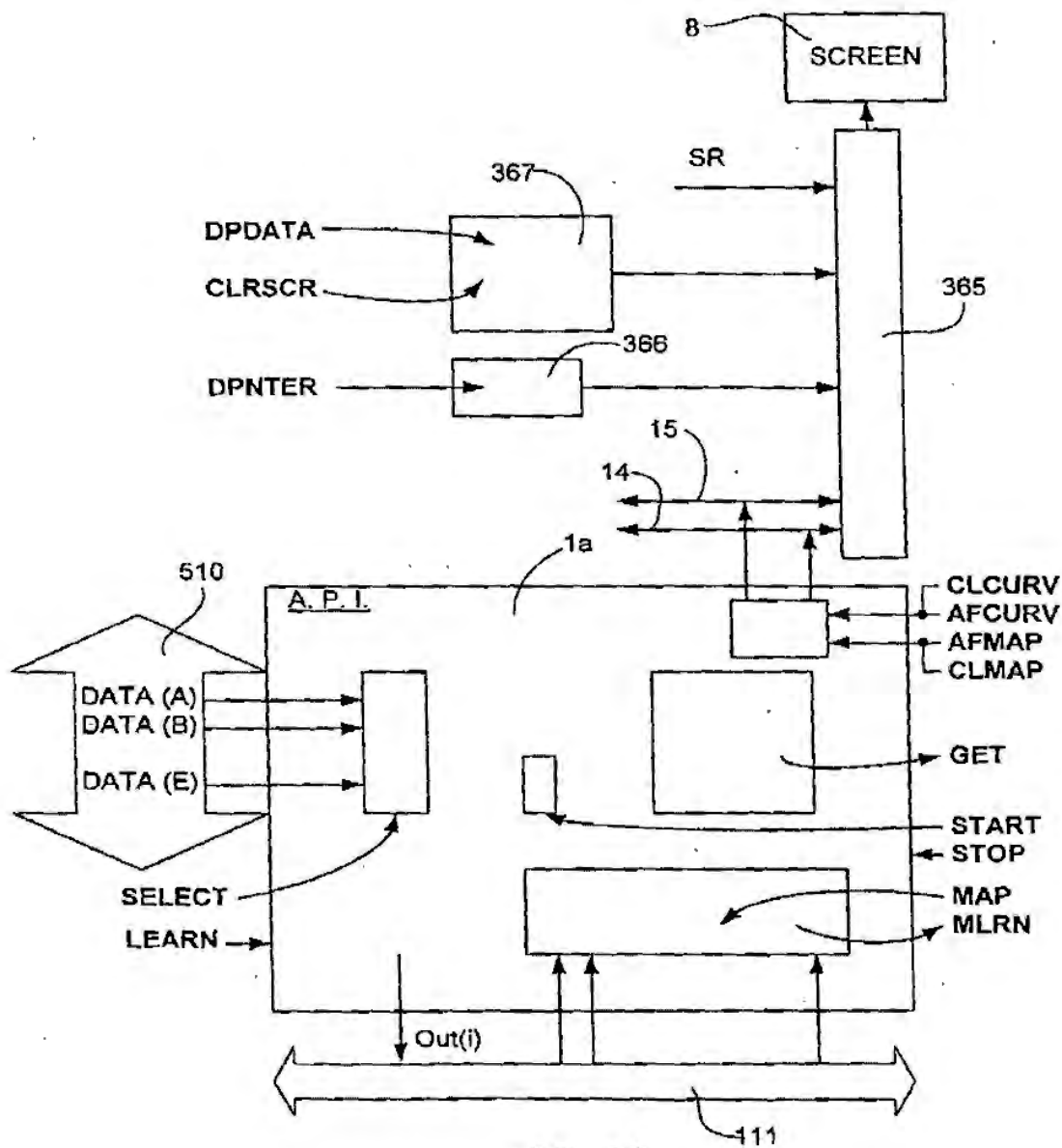

FIG. 38

202210 92547288

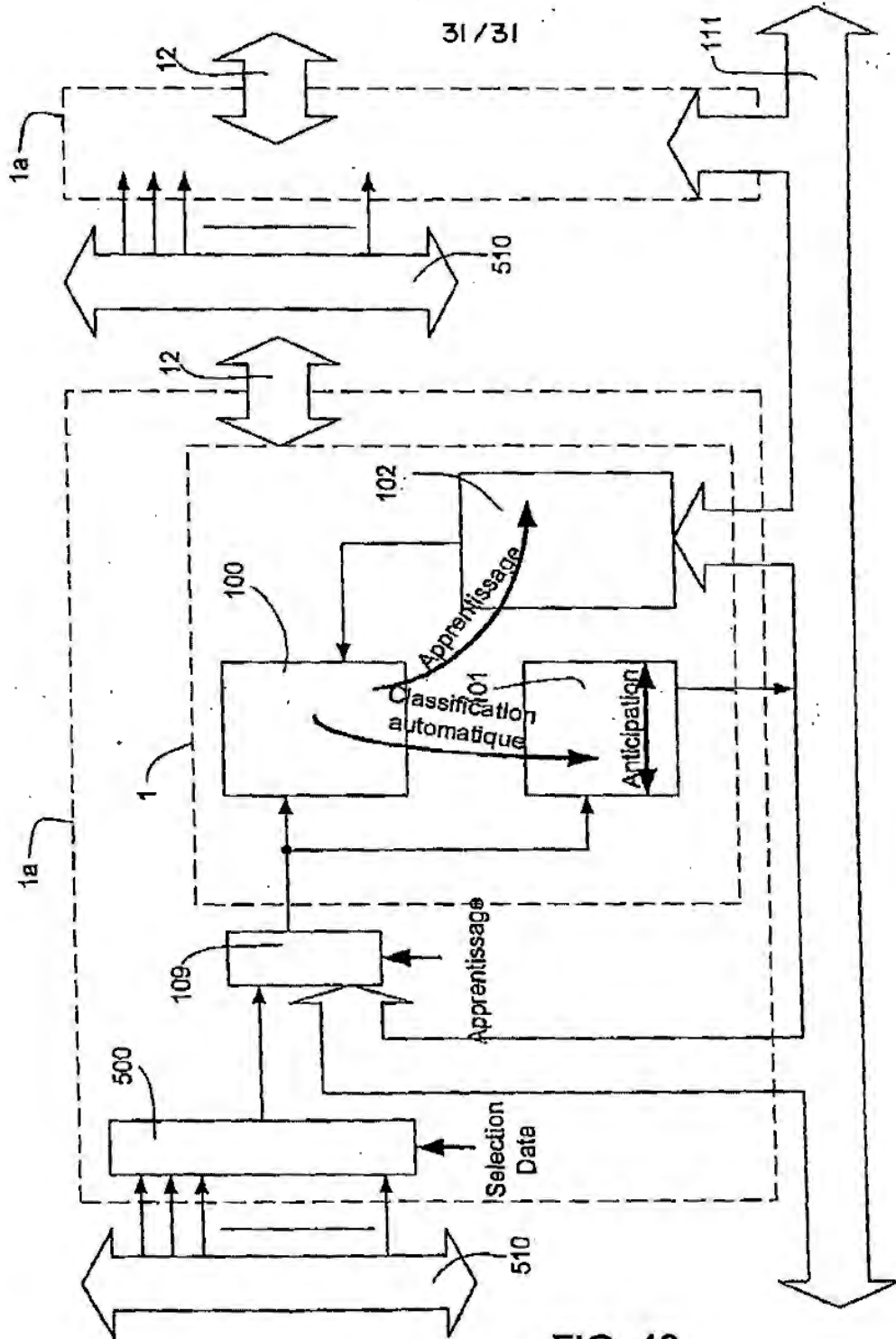

FIG. 40



UNITED STATES PATENT AND TRADEMARK OFFICE

UNITED STATES DEPARTMENT OF COMMERCE
United States Patent and Trademark Office
Address: COMMISSIONER OF PATENTS AND TRADEMARKS
Washington, D.C. 20231
www.uspto.gov

Application Number	Filing Date	First Named Applicant	Atty. Docket No.
09/792,436	02/23/2001	Pirim, Patrick	20046H-000100US

20350
TOWNSEND AND TOWNSEND AND CREW, LLP
TWO EMBARCADERO CENTER
EIGHTH FLOOR
SAN FRANCISCO CA 94111-3834

Title: Method and device for automatic visual perception

Date Mailed: 03/22/2002

Request for Substitute Papers

The papers filed on 01/22/02 (certificate of mailing dated 10/22/01) are no longer in condition to become part of the permanent records of the United States Patent and Trademark Office (USPTO) for this application (37 CFR 1.52(a)) due to the United States Postal Service sanitization process.

The USPTO requests that applicant provide a copy of the above-identified papers (except for any U.S. or foreign patent documents submitted with the above-identified papers) with a statement that such copy is a complete and accurate copy of the above-identified papers (signing and returning a copy of this notice will provide such a statement). The reply to this letter should be submitted to the USPTO by facsimile at the number indicated **703-746-4060(OIPE)**.

Alternatively, the reply to this letter may be hand-carried to the Customer Service Window located in Room 1B03 of Crystal Plaza Building 2, Arlington, Virginia, 22202.

The USPTO **strongly** prefers that the reply to this letter be submitted by facsimile. However, if applicant cannot submit the reply to this letter by facsimile (or hand-delivery), the reply may be mailed to: Box Duplicate OIPE, U.S. Patent and Trademark Office, P.O. Box 2327, Arlington, VA 22202-2327.

This letter is not a notice under 37 CFR 1.251. However, failure to timely replay to this notice within **two (2) weeks** of the date of receipt of this letter may result in the USPTO issuing a notice under 37 CFR 1.251. **A copy of this notice should be included with the reply.**

The enclosed papers are a complete and accurate copy of the above-identified papers.

Name: _____ Registration No.: _____

Signature: _____ Date: _____