



(19) **United States**

(12) **Patent Application Publication**
Ketchum et al.

(10) **Pub. No.: US 2004/0179627 A1**

(43) **Pub. Date: Sep. 16, 2004**

(54) **PILOTS FOR MIMO COMMUNICATION SYSTEMS**

Publication Classification

(76) Inventors: **John W. Ketchum**, Harvard, MA (US);
Mark S. Wallace, Bedford, MA (US);
J. Rodney Walton, Carlisle, MA (US);
Steven J. Howard, Ashland, MA (US)

(51) **Int. Cl.⁷ H04L 1/02**

(52) **U.S. Cl. 375/267**

(57) **ABSTRACT**

Correspondence Address:
Qualcomm Incorporated
Patents Department
5775 Morehouse Drive
San Diego, CA 92121-1714 (US)

(21) Appl. No.: **10/610,446**

(22) Filed: **Jun. 30, 2003**

Related U.S. Application Data

(60) Provisional application No. 60/421,309, filed on Oct. 25, 2002. Provisional application No. 60/421,462, filed on Oct. 25, 2002. Provisional application No. 60/421,428, filed on Oct. 25, 2002. Provisional application No. 60/432,617, filed on Dec. 10, 2002. Provisional application No. 60/438,601, filed on Jan. 7, 2003.

Pilots suitable for use in MIMO systems and capable of supporting various functions are described. The various types of pilot include—a beacon pilot, a MIMO pilot, a steered reference or steered pilot, and a carrier pilot. The beacon pilot is transmitted from all transmit antennas and may be used for timing and frequency acquisition. The MIMO pilot is transmitted from all transmit antennas but is covered with different orthogonal codes assigned to the transmit antennas. The MIMO pilot may be used for channel estimation. The steered reference is transmitted on specific eigenmodes of a MIMO channel and is user terminal specific. The steered reference may be used for channel estimation. The carrier pilot may be transmitted on designated subbands/antennas and may be used for phase tracking of a carrier signal. Various pilot transmission schemes may be devised based on different combinations of these various types of pilot.

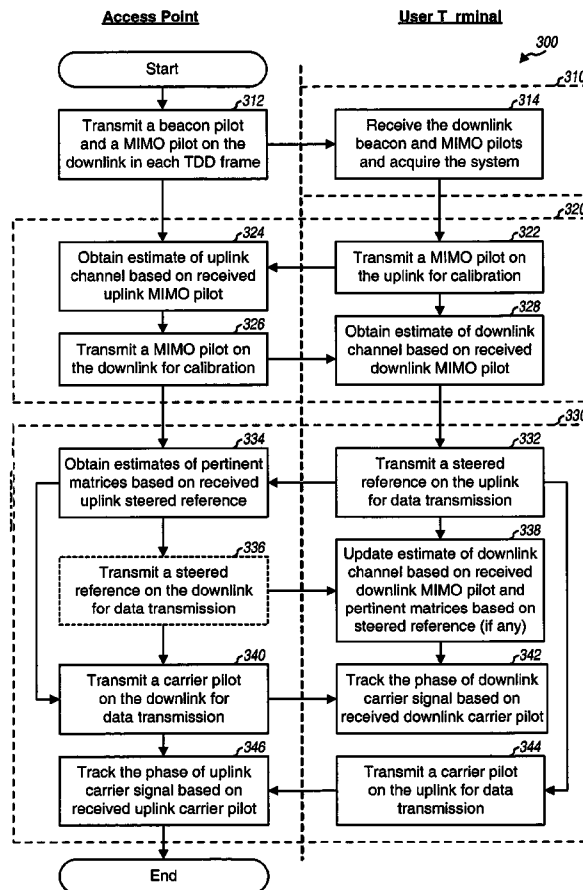

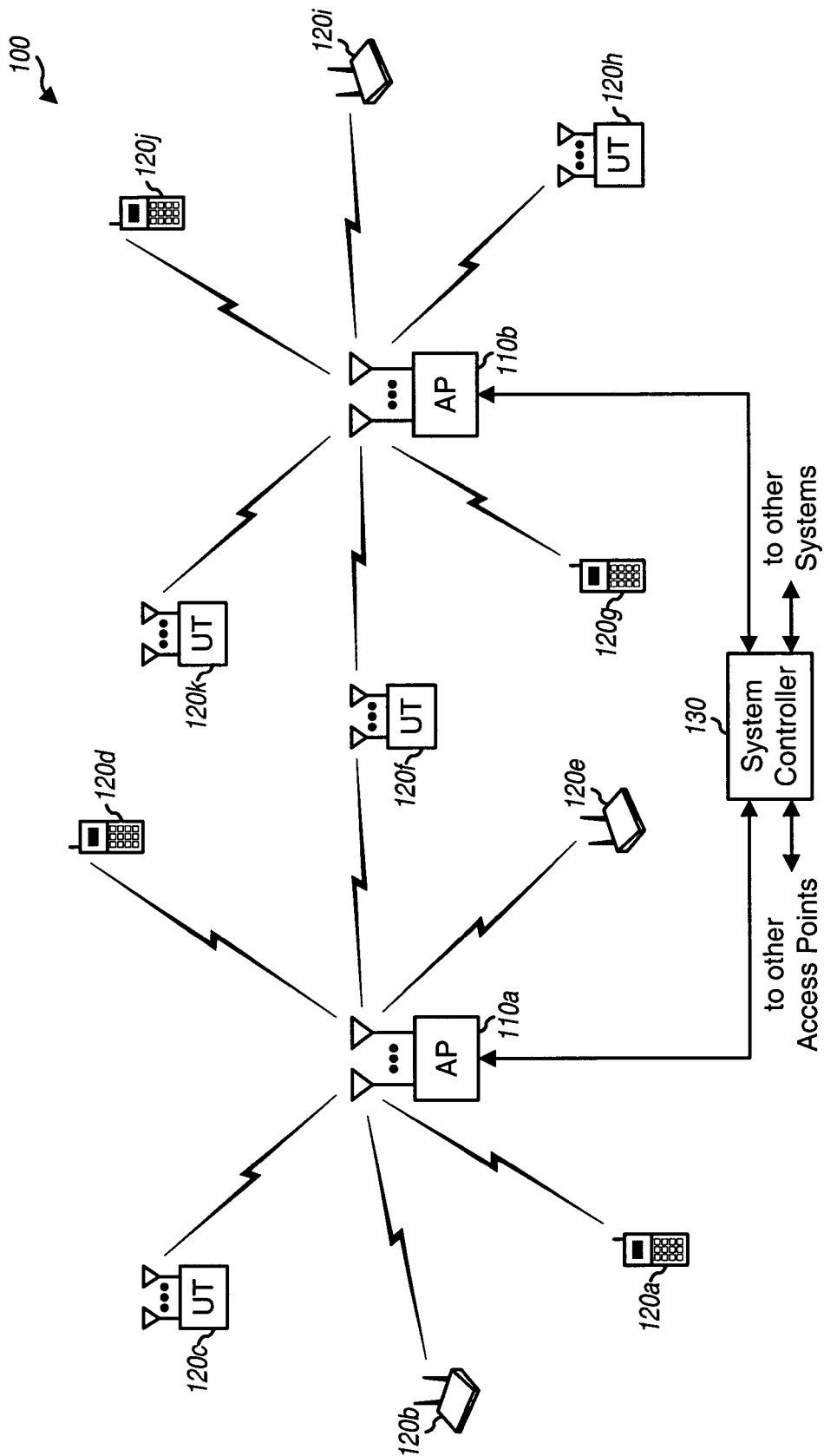

FIG. 1

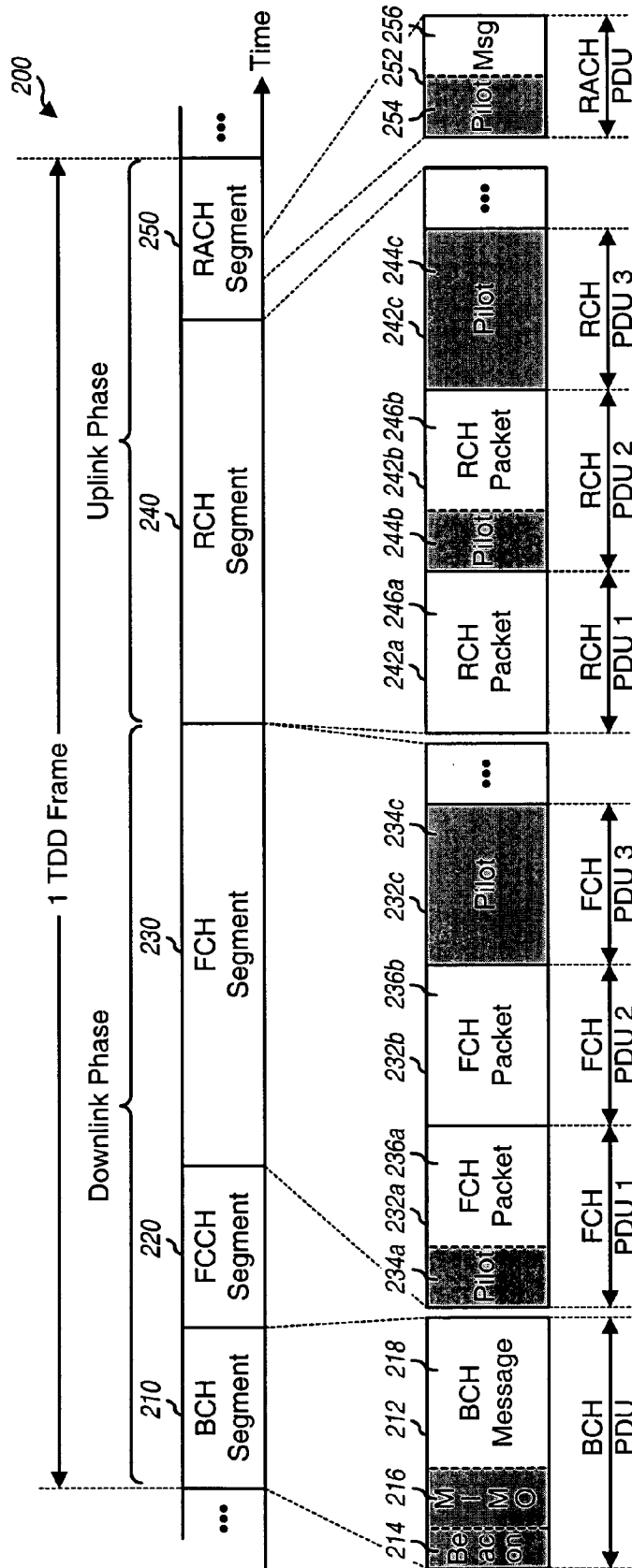

FIG. 2

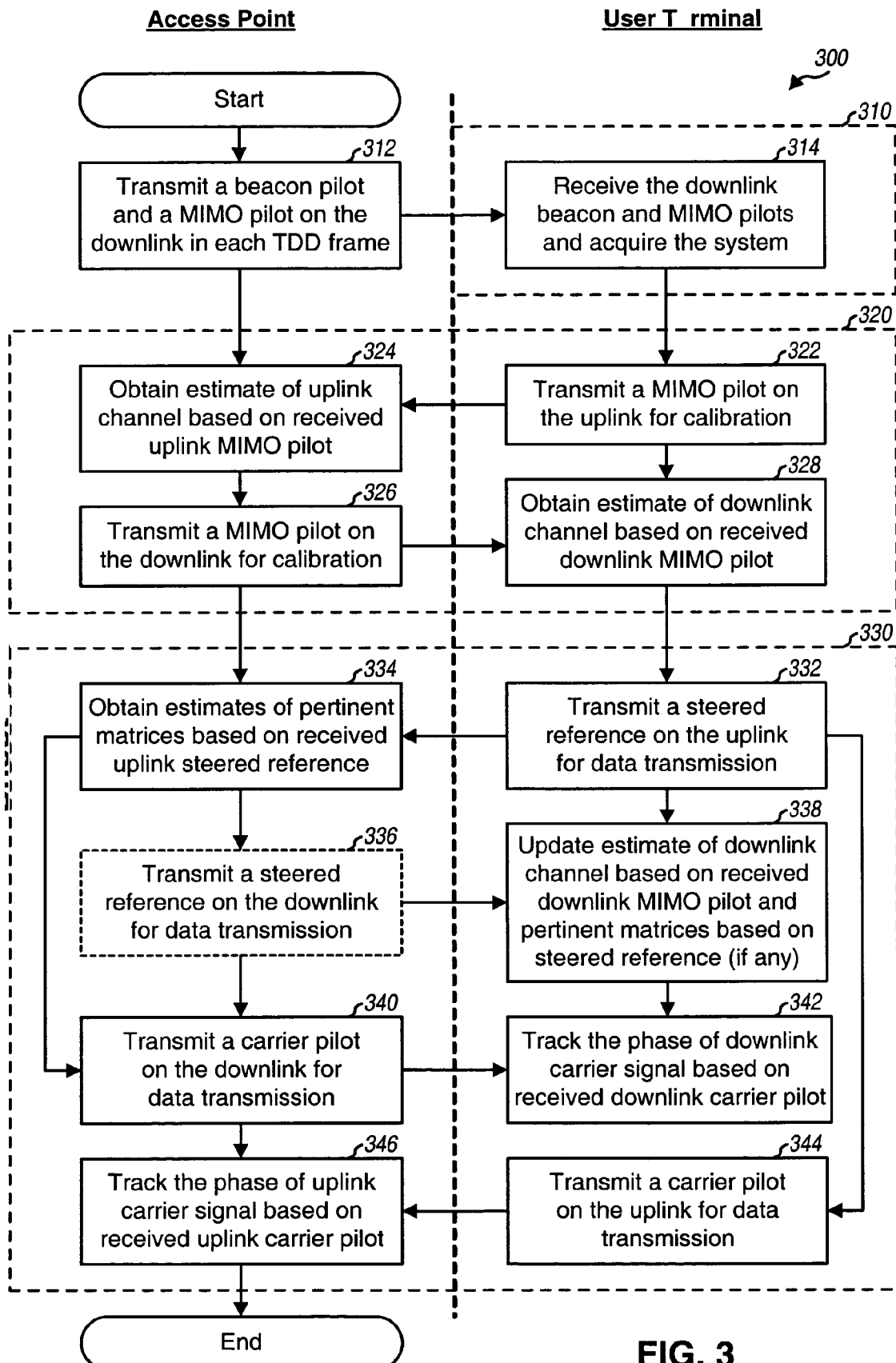

FIG. 3

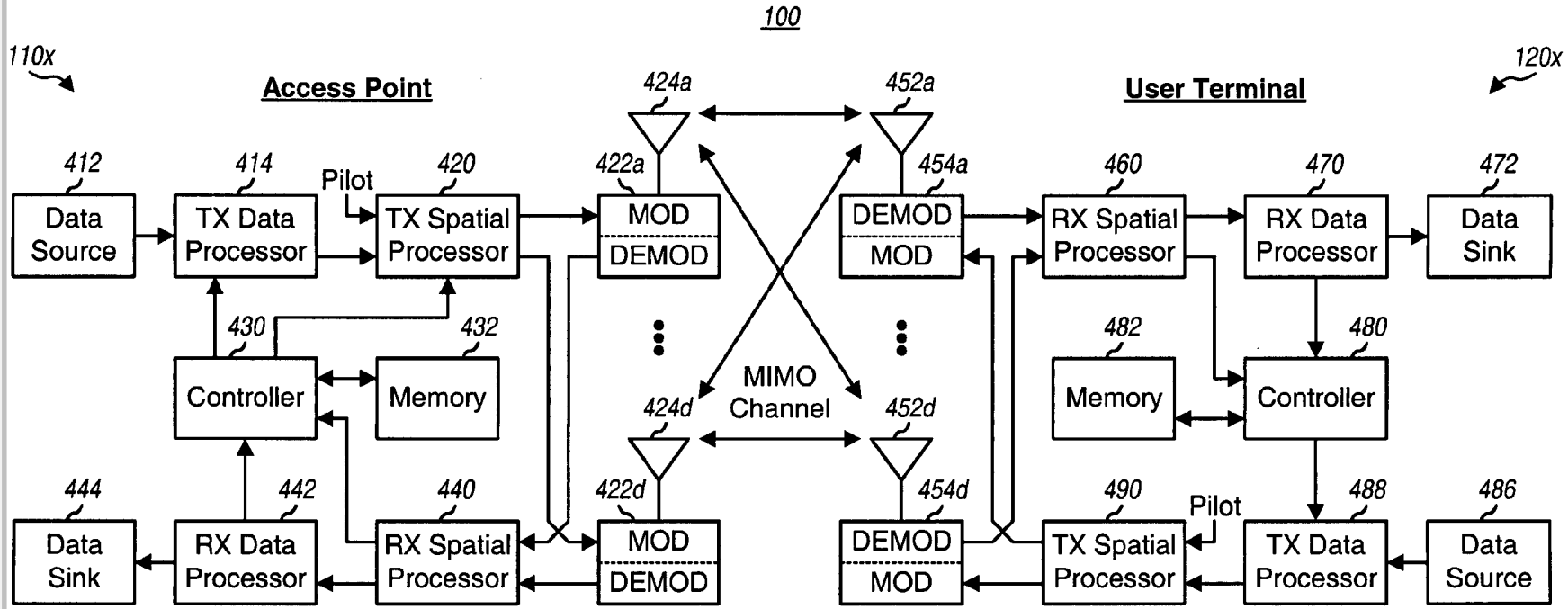

FIG. 4

Explore Litigation Insights

Docket Alarm provides insights to develop a more informed litigation strategy and the peace of mind of knowing you're on top of things.

Real-Time Litigation Alerts



Keep your litigation team up-to-date with **real-time alerts** and advanced team management tools built for the enterprise, all while greatly reducing PACER spend.

Our comprehensive service means we can handle Federal, State, and Administrative courts across the country.

Advanced Docket Research



With over 230 million records, Docket Alarm's cloud-native docket research platform finds what other services can't. Coverage includes Federal, State, plus PTAB, TTAB, ITC and NLRB decisions, all in one place.

Identify arguments that have been successful in the past with full text, pinpoint searching. Link to case law cited within any court document via Fastcase.

Analytics At Your Fingertips



Learn what happened the last time a particular judge, opposing counsel or company faced cases similar to yours.

Advanced out-of-the-box PTAB and TTAB analytics are always at your fingertips.

API

Docket Alarm offers a powerful API (application programming interface) to developers that want to integrate case filings into their apps.

LAW FIRMS

Build custom dashboards for your attorneys and clients with live data direct from the court.

Automate many repetitive legal tasks like conflict checks, document management, and marketing.

FINANCIAL INSTITUTIONS

Litigation and bankruptcy checks for companies and debtors.

E-DISCOVERY AND LEGAL VENDORS

Sync your system to PACER to automate legal marketing.