



(12) **United States Patent**  
**Catchpole**

(10) **Patent No.:** **US 10,971,140 B2**  
(45) **Date of Patent:** **Apr. 6, 2021**

(54) **SPEECH RECOGNITION CIRCUIT USING PARALLEL PROCESSORS**

(71) Applicant: **Zentian Limited**, Cambridge (GB)  
(72) Inventor: **Mark Catchpole**, Prickwillow (GB)  
(73) Assignee: **Zentian Limited**, Cambridge (GB)  
(\* ) Notice: Subject to any disclaimer, the term of this patent is extended or adjusted under 35 U.S.C. 154(b) by 0 days.

(21) Appl. No.: **16/266,265**

(22) Filed: **Feb. 4, 2019**

(65) **Prior Publication Data**  
US 2019/0172447 A1 Jun. 6, 2019

**Related U.S. Application Data**

(63) Continuation of application No. 15/392,396, filed on Dec. 28, 2016, now Pat. No. 10,217,460, which is a (Continued)

(30) **Foreign Application Priority Data**

Feb. 4, 2002 (GB) ..... 0202546

(51) **Int. Cl.**  
**G10L 15/32** (2013.01)  
**G10L 15/187** (2013.01)  
(Continued)

(52) **U.S. Cl.**  
CPC ..... **G10L 15/187** (2013.01); **G10L 15/05** (2013.01); **G10L 15/34** (2013.01)

(58) **Field of Classification Search**  
CPC ..... G10L 15/32; G10L 15/34  
See application file for complete search history.

(56) **References Cited**

U.S. PATENT DOCUMENTS

4,977,599 A \* 12/1990 Bahl ..... G10L 15/02 704/256.4  
4,980,918 A \* 12/1990 Bahl ..... G10L 15/08 704/240

(Continued)

FOREIGN PATENT DOCUMENTS

GB 2 112 194 A 7/1983  
GB 2 331 392 A 5/1999

(Continued)

OTHER PUBLICATIONS

R.M. Woodward et al., "Tissue Classification Using Terahertz Pulsed Imaging", Proceedings of the SPIE—The International Society for Optical Engineering SPIE-INT. Soc. Opt. Eng. USA, vol. 5318, No. 1, 2004, pp. 23-33. Abstract also attached.

(Continued)

*Primary Examiner* — Daniel Abebe

(74) *Attorney, Agent, or Firm* — Finnegan Henderson Farabow Garrett & Dunner LLP

(57) **ABSTRACT**

A speech recognition circuit comprises an input buffer for receiving processed speech parameters. A lexical memory contains lexical data for word recognition. The lexical data comprises a plurality of lexical tree data structures. Each lexical tree data structure comprises a model of words having common prefix components. An initial component of each lexical tree structure is unique. A plurality of lexical tree processors are connected in parallel to the input buffer for processing the speech parameters in parallel to perform parallel lexical tree processing for word recognition by accessing the lexical data in the lexical memory. A results memory is connected to the lexical tree processors for storing processing results from the lexical tree processors and lexical tree identifiers to identify lexical trees to be processed by the lexical tree processors. A controller controls the lexical tree processors to process lexical trees

(Continued)

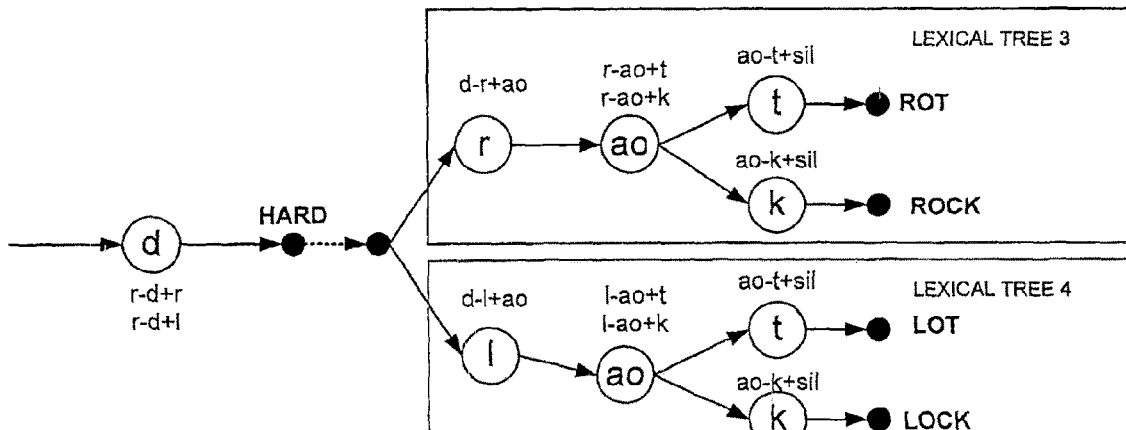

identified in the results memory by performing parallel processing on a plurality of said lexical tree data structures.

**8 Claims, 6 Drawing Sheets**

**Related U.S. Application Data**

continuation of application No. 14/309,476, filed on Jun. 19, 2014, now Pat. No. 9,536,516, which is a continuation of application No. 13/253,223, filed on Oct. 5, 2011, now Pat. No. 8,768,696, which is a continuation of application No. 12/554,607, filed on Sep. 4, 2009, now Pat. No. 8,036,890, which is a continuation of application No. 10/503,463, filed as application No. PCT/GB03/00459 on Feb. 4, 2003, now Pat. No. 7,587,319.

- (51) **Int. Cl.**  
*G10L 15/34* (2013.01)  
*G10L 15/05* (2013.01)

- (56) **References Cited**

U.S. PATENT DOCUMENTS

5,293,213 A	3/1994	Klein et al.	
5,349,645 A	9/1994	Zhao	
5,457,768 A	10/1995	Tsuboi	
5,579,436 A *	11/1996	Chou .....	G10L 15/063 704/236
5,621,859 A	4/1997	Schwartz	
5,710,866 A *	1/1998	Alleva .....	G10L 15/10 704/246
5,832,428 A	11/1998	Chow	
5,881,312 A	3/1999	Dulong	
5,960,395 A	9/1999	Tzirkel-Hanock	
5,983,180 A *	11/1999	Robinson .....	G10L 15/142 704/254
5,995,930 A	11/1999	Hab-Umbach et al.	
6,047,283 A	4/2000	Braun	
6,374,222 B1	4/2002	Kao	
6,526,380 B1	2/2003	Thelen	
7,024,359 B2 *	4/2006	Chang .....	G10L 15/065 704/251
7,035,802 B1	4/2006	Rigazio	
7,065,488 B2 *	6/2006	Yajima .....	G10L 15/20 704/226
7,120,582 B1	10/2006	Young et al.	
7,174,037 B2	2/2007	Arnone et al.	
7,899,669 B2	3/2011	Gadbois	
2001/0011218 A1	8/2001	Phillips et al.	
2002/0143531 A1	10/2002	Kahn	

2003/0178584 A1	9/2003	Arnone et al.	
2005/0119883 A1 *	6/2005	Miyazaki .....	G10L 15/142 704/231
2008/0255839 A1	10/2008	Larri et al.	

FOREIGN PATENT DOCUMENTS

GB	2 347 835 A	9/2000
GB	2 380 920 A	4/2003
WO	WO 00/50859	8/2000
WO	WO-03/067572 A2	8/2003

OTHER PUBLICATIONS

V.P. Wallace et al., "Biomedical Applications of THz Imaging", Microwave Symposium Digest, 2004, IEEE MTT-S International Fort Worth, TX, USA, Jun. 6-11, 2004, Piscataway, NJ, USA, IEEE, vol. 3, Jun. 6, 2004 (Jun. 6, 2004), pp. 1579-1581.

V.P. Wallace et al., "Biomedical Applications of Terahertz Pulse Imaging", Second Joint EMBS-BMES Conference 2002. Conference Proceedings. 24th Annual International Conference of the Engineering in Medicinal and Biology Society. Annual Fall Meeting of the Biomedical Engineering Society, Houston, TX, Oct. 23-26, 2002, Annual vol. 1 of 3. Conf. 24, Oct. 23, 2002 (Oct. 23, 2002), pp. 2333-2334.

A.J. Fitzgerald et al., "Terahertz Imaging of Breast Cancer, a Feasibility Study", Conference Digest of the 2004 Joint 29th International Conference on Infrared and Millimeter Waves and 12th International Conference on Terahertz Electronics IEEE Piscataway, NJ, USA, 2004, pp. 823-824.

B.E. Cole et al., "Terahertz Imaging and Spectroscopy of Human Skin, In-vivo", Proceedings of SPIE, vol. 4276, pp. 1-10.

S. Glinski et al., "Spoken Language Recognition on a DSP Array Processor", IEEE Transactions on Parallel and Distributed Systems, Jul. 5, 1994, No. 7, New York, USA, pp. 697-703.

S. Chatterjee et al., "Connected Speech Recognition on a Multiple Processor Pipeline", ICASSP 89, May 23, 1989, Glasgow, UK, pp. 774-777.

S. H. Chung et al. "A Parallel Phoneme Recognition Algorithm Based on Continuous Hidden Markov Model", Proceedings 13th International Parallel Processing Symposium and 10th Symposium on Parallel and Distributed Processing, IPPS/SPDP 1999, Proceedings of 13th International Parallel Processing Symposium and 10th Symposium on Parallel and Distributed Pro, IEEE Comput. Soc. pp. 453-457 (1999).

S.H. Chung et al. "A Parallel Computation Model for Integrated Speech and Natural Language Understanding", IEEE Transactions on Computers, vol. 42, No. 10, Oct. 1, 1993.

N. Deshmukh et al. "Hierarchical Search for Large-Vocabulary Conversational Speech Recognition: Working Toward a Solution to the Decoding Problem", IEEE Signal Processing Magazine, vol. 16, No. 5, pp. 84-107 (Sep. 1999).

\* cited by examiner

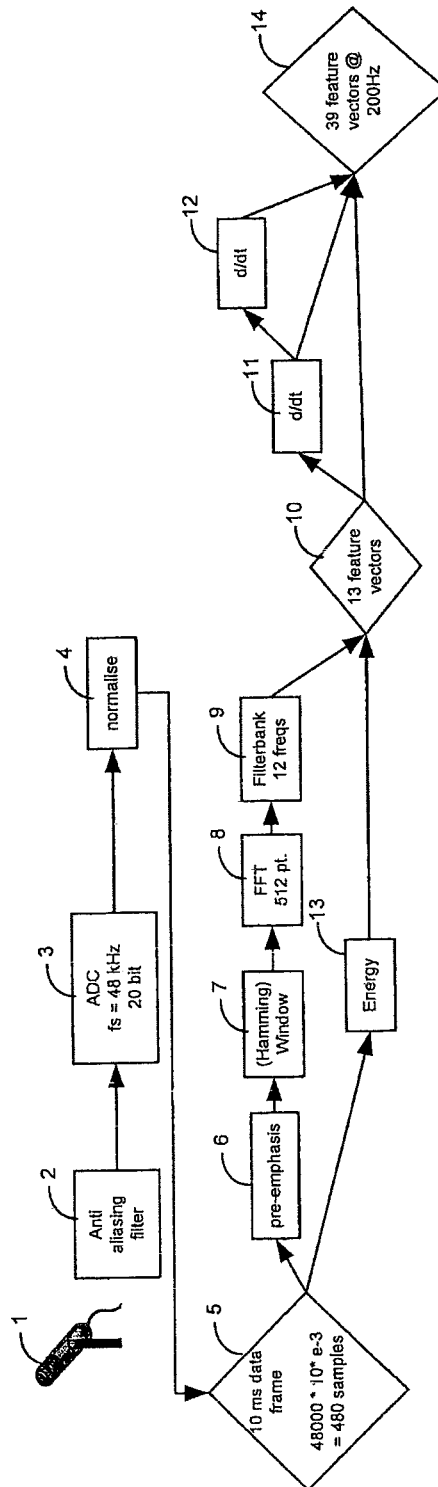

Fig 1

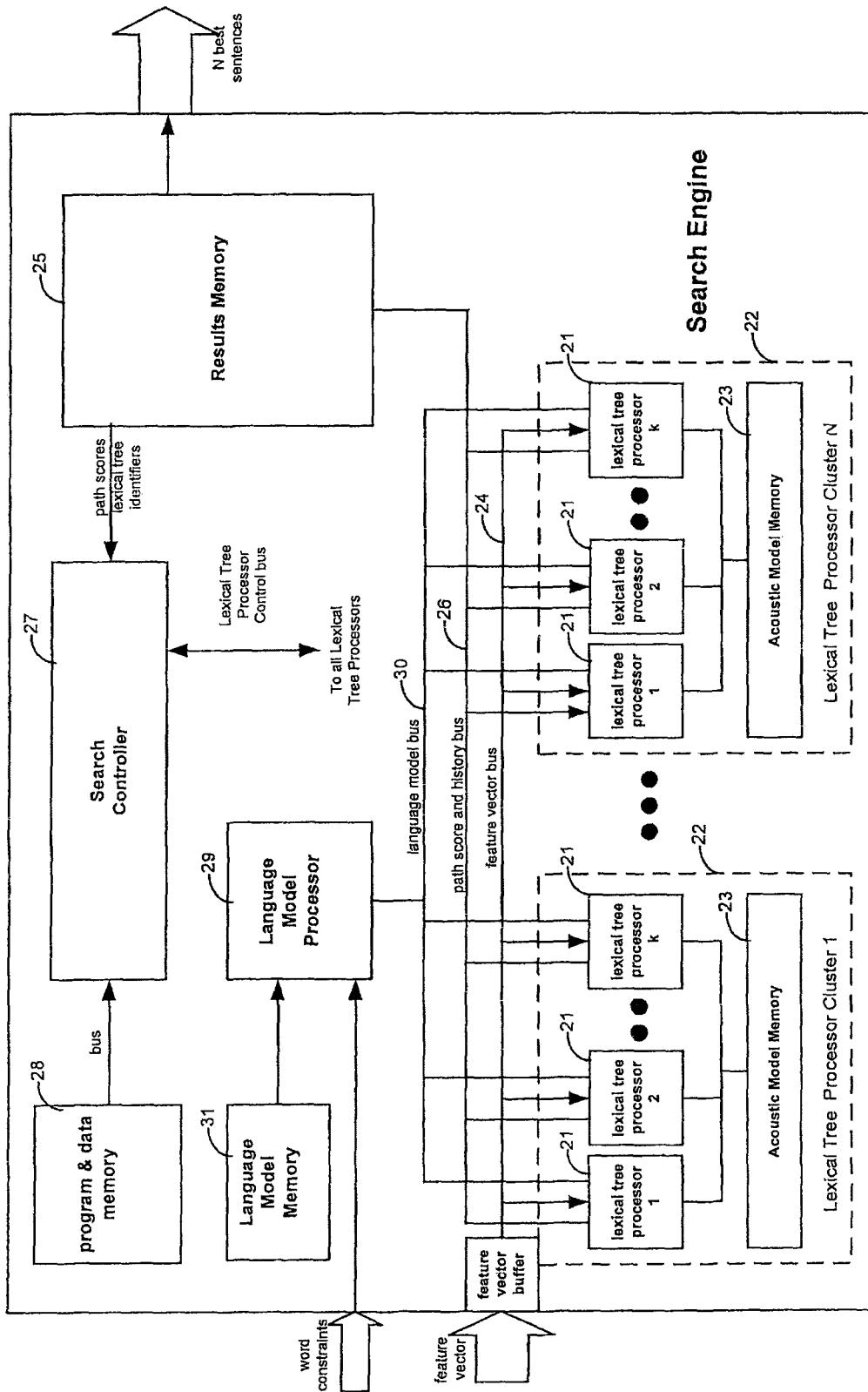
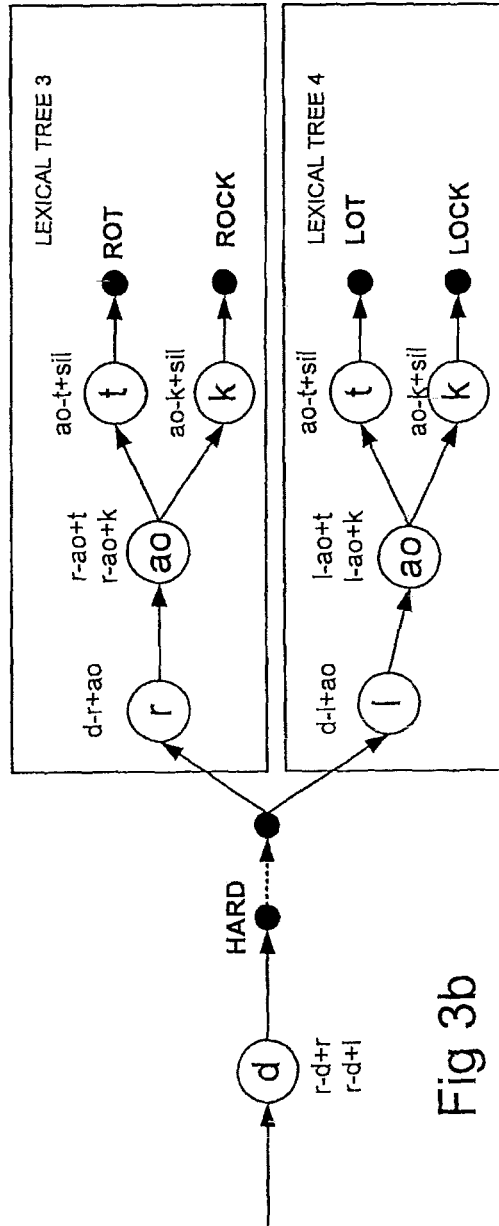
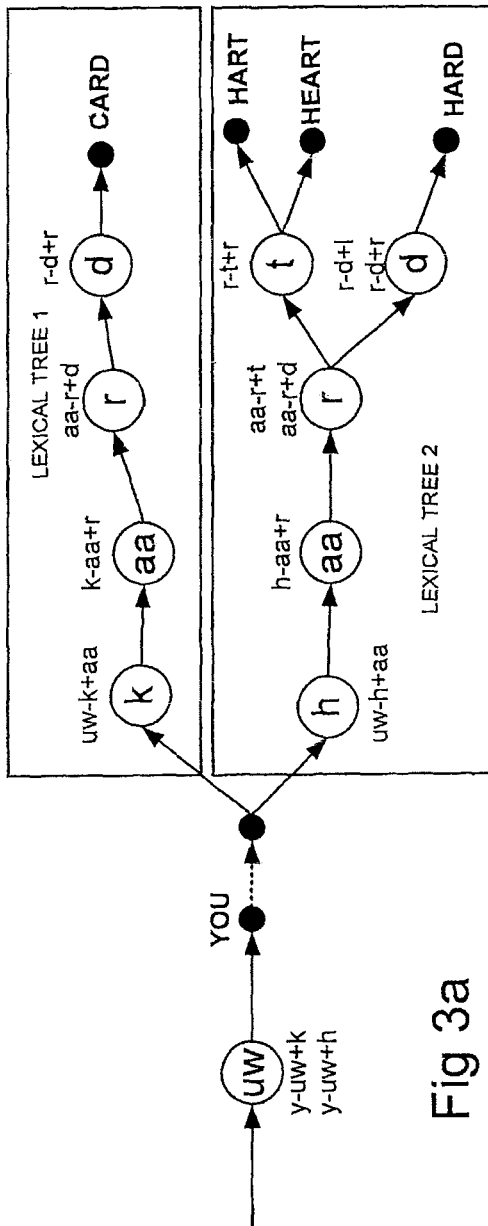

Fig 2



# Explore Litigation Insights

Docket Alarm provides insights to develop a more informed litigation strategy and the peace of mind of knowing you're on top of things.

## Real-Time Litigation Alerts



Keep your litigation team up-to-date with **real-time alerts** and advanced team management tools built for the enterprise, all while greatly reducing PACER spend.

Our comprehensive service means we can handle Federal, State, and Administrative courts across the country.

## Advanced Docket Research



With over 230 million records, Docket Alarm's cloud-native docket research platform finds what other services can't. Coverage includes Federal, State, plus PTAB, TTAB, ITC and NLRB decisions, all in one place.

Identify arguments that have been successful in the past with full text, pinpoint searching. Link to case law cited within any court document via Fastcase.

## Analytics At Your Fingertips



Learn what happened the last time a particular judge, opposing counsel or company faced cases similar to yours.

Advanced out-of-the-box PTAB and TTAB analytics are always at your fingertips.

## API

Docket Alarm offers a powerful API (application programming interface) to developers that want to integrate case filings into their apps.

## LAW FIRMS

Build custom dashboards for your attorneys and clients with live data direct from the court.

Automate many repetitive legal tasks like conflict checks, document management, and marketing.

## FINANCIAL INSTITUTIONS

Litigation and bankruptcy checks for companies and debtors.

## E-DISCOVERY AND LEGAL VENDORS

Sync your system to PACER to automate legal marketing.