



US006141441A

United States Patent [19]

[11] Patent Number: **6,141,441**

Cass et al.

[45] Date of Patent: **Oct. 31, 2000**

[54] **DECODING DATA FROM PATTERNED COLOR MODULATED IMAGE REGIONS IN A COLOR IMAGE**

[75] Inventors: **Todd A. Cass**, San Francisco, Calif.; **Xin Tong**, Jacksonville, Fla.

[73] Assignee: **Xerox Corporation**, Stamford, Conn.

[21] Appl. No.: **09/162,257**

[22] Filed: **Sep. 28, 1998**

[51] Int. Cl.⁷ **G06K 9/00**

[52] U.S. Cl. **382/166; 382/232; 235/494**

[58] Field of Search **382/166, 167, 382/232, 183, 233; 235/469, 494**

Johnston, R.B.; Yap, A. K. C. Two Dimensional Bar Code as a Medium for Electronic Data Interchange. *Two Dimensional Bar Code*. pp. 1–10. <http://www.bs.monash.edu.au/staff/johnno/BARCOPAW.html>.

Nelson, B. Secret Codes? *Automatic I.D. News* . pp. 1–2. <http://www.autoidnews.com/technologies/concepts/secret.htm>.

The ‘Big 3’ Dominate 2D Symboloty Use. *Automatic I.D. News*. pp. 1–2. <http://www.autoidnews.com/technologies/concepts/big3.htm>.

Primary Examiner—Amelia Au
Assistant Examiner—Jingge Wu

[57] ABSTRACT

A technique for decoding message data that has been encoded into a printed color image locates small image regions called signal cells that carry the encoded message. Each signal cell is composed of a spatial pattern of colored subregions that collectively have an overall average color. The colors of the subregions are defined as changes (modulations) to the average color in one or more directions in a multi-dimensional color space. The decoding technique uses a set of valid signal blocks, each of which is a unique pattern of color modulated subregions. There is a valid signal block for each valid message value defined in the coding scheme. The decoding operation first locates the positions of the signal cells in the acquired image and then subtracts the local average color of each signal cell from the cell to produce a received signal block. Then the decoding operation determines which valid signal block each received signal block is by comparing each valid signal block to a received signal block. One implementation of the decoding technique decodes signal cells that have been arranged in the acquired image in a 2D array by synchronizing an imaginary grid-like structure with the most likely position of all of the signal cells. In one embodiment, a color space direction is selected for the color modulations that results in the differently colored subregions of a signal cell being substantially imperceptible to a human viewer, thus making the pattern that carries the message substantially imperceptible in an encoded image.

[56] References Cited

U.S. PATENT DOCUMENTS

4,443,694	4/1984	Sanford	235/465
5,221,833	6/1993	Hecht	235/494
5,245,165	9/1993	Zhang	235/454
5,278,400	1/1994	Appel	235/494
5,315,098	5/1994	Tow	235/494
5,369,261	11/1994	Shamir	235/469
5,619,026	4/1997	Chou et al.	235/462
5,684,885	11/1997	Cass et al.	382/100
6,070,805	6/2000	Kaufman et al.	235/494

FOREIGN PATENT DOCUMENTS

63-254586	10/1988	Japan
WO 95/14289	5/1995	WIPO

OTHER PUBLICATIONS

Cox, I. J.; Kilian, J.; Leighton, T.; Shamoon, T. Secure Spread Spectrum Watermarking for Multimedia. NEC Research Institute, Technical Repot 95–10, pp. 1–33.

Antognini, T.; Antognini, W. A Flexibly Configurable 2D Bar Code. pp. 1–26. <http://www.paperdisk.com/ibippa-pr.htm>.

Aurora bar code technologies ltd. Two-Dimensional Bar Codes. The Biggest Advance in Bar Code Technology in Recent Years. *Code Facts*. pp. 1–2. <http://www.dimension-x.com/cf-2d.htm>.

13 Claims, 22 Drawing Sheets

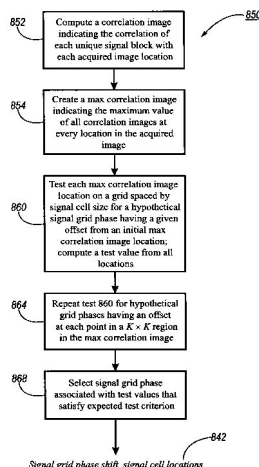

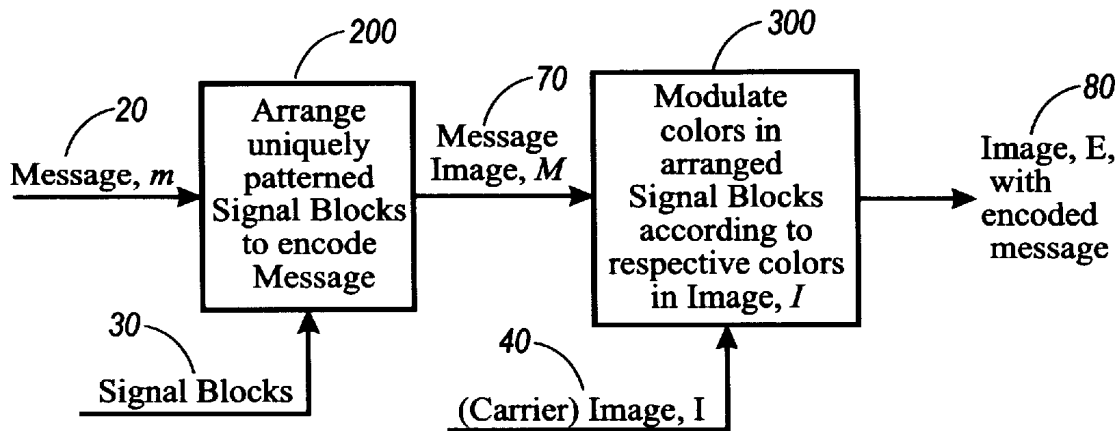

FIG. 1

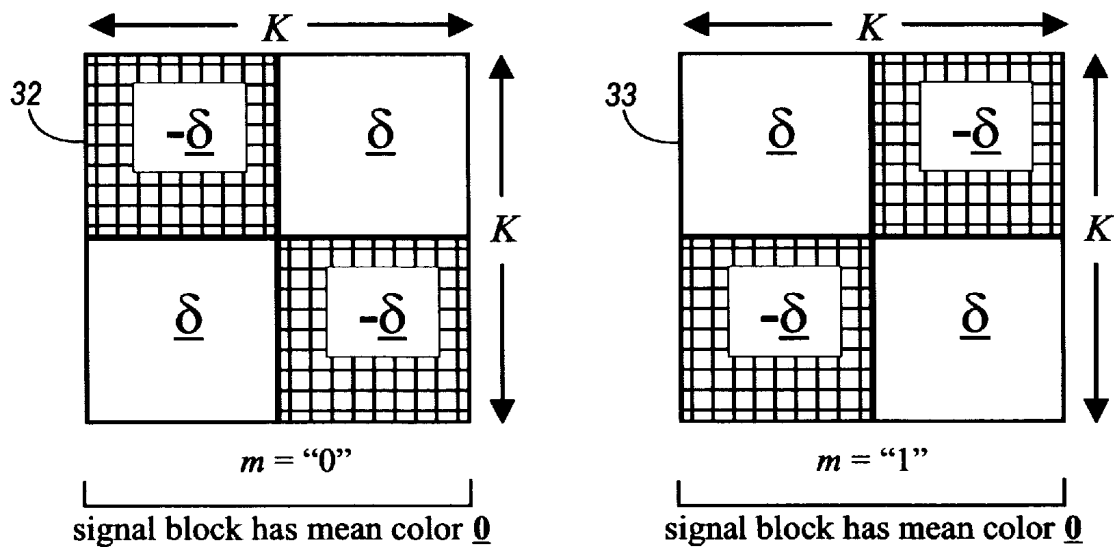

FIG. 2

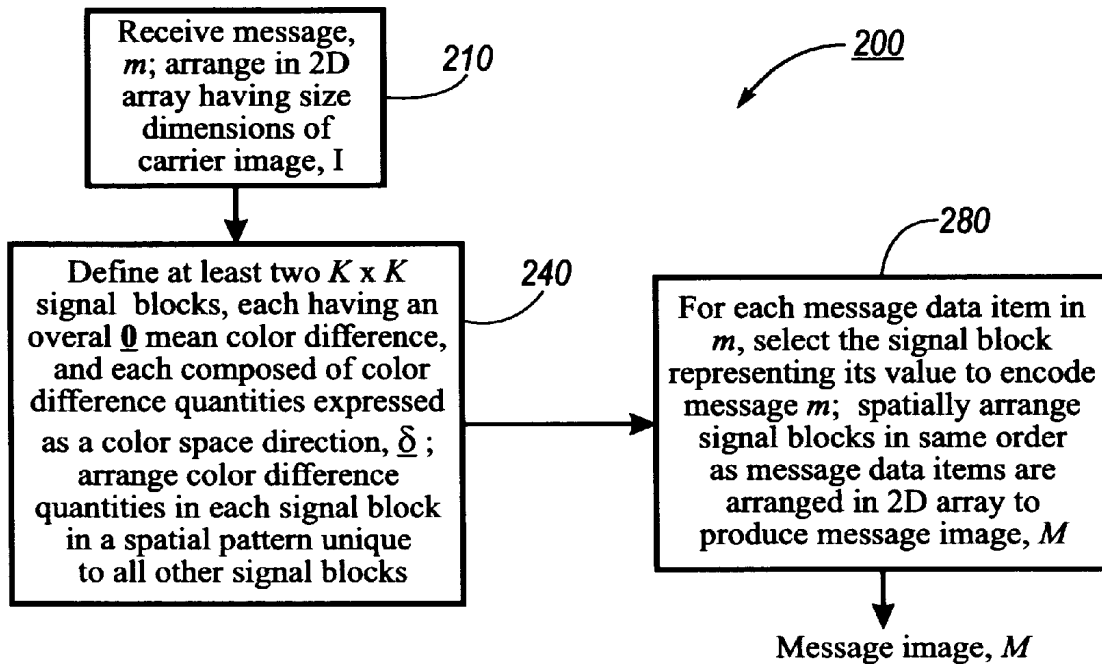

FIG. 3

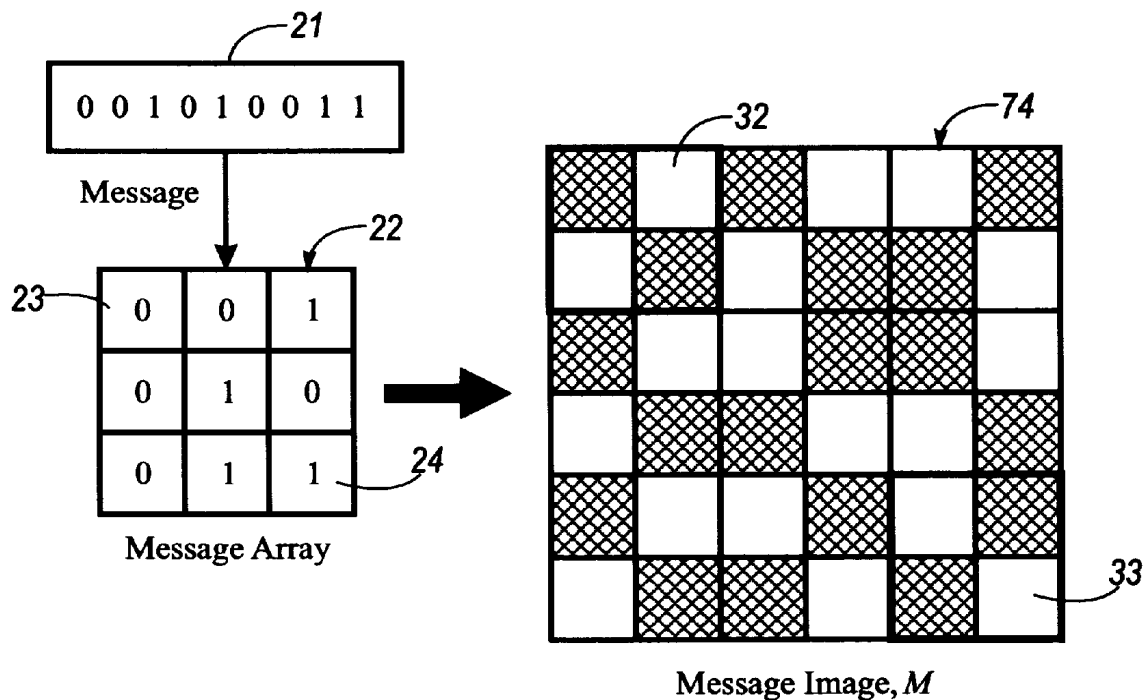

FIG. 4

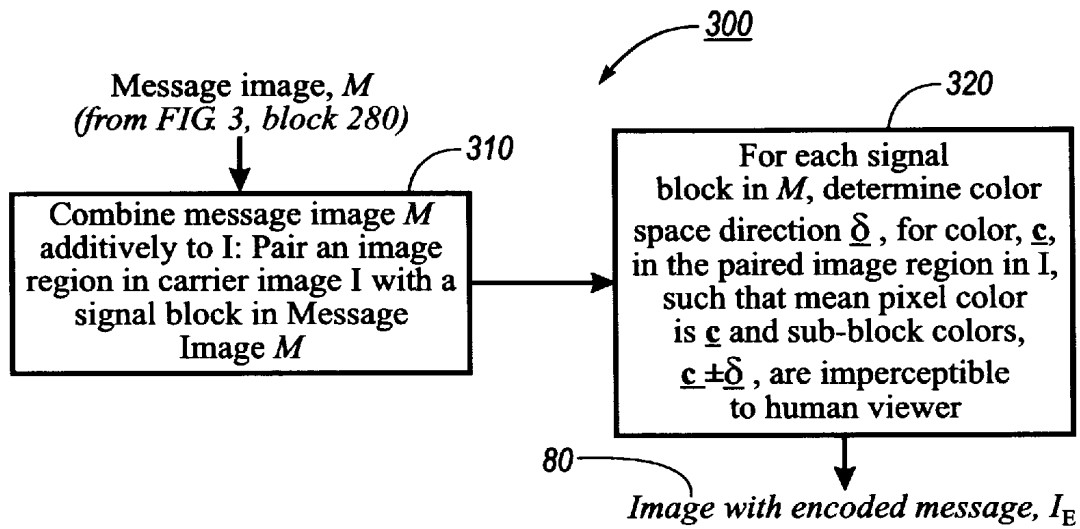

FIG. 5

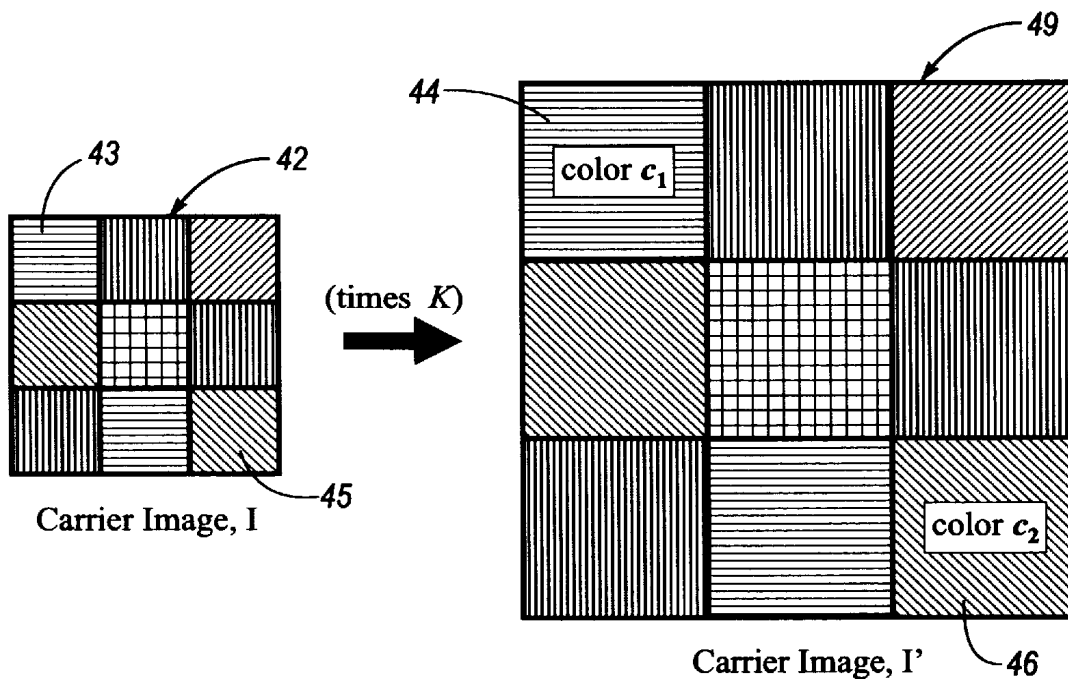

FIG. 6

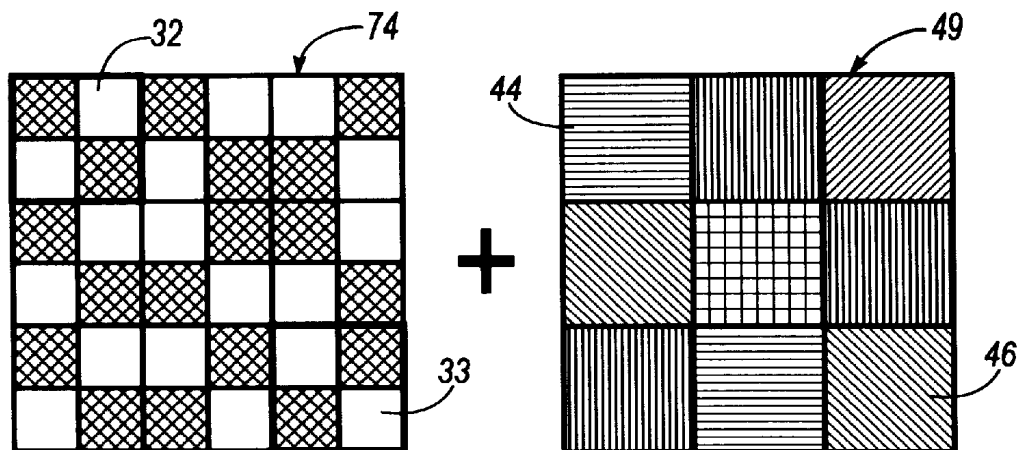

FIG. 7

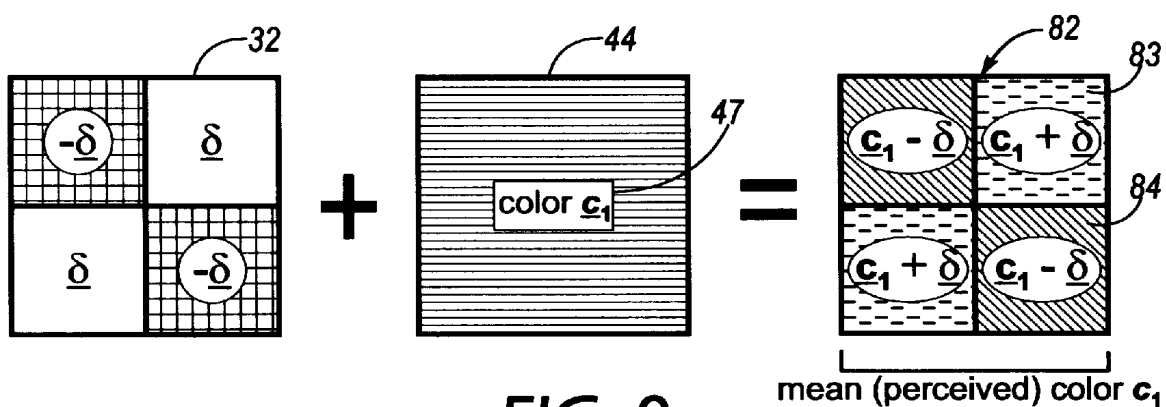

FIG. 8

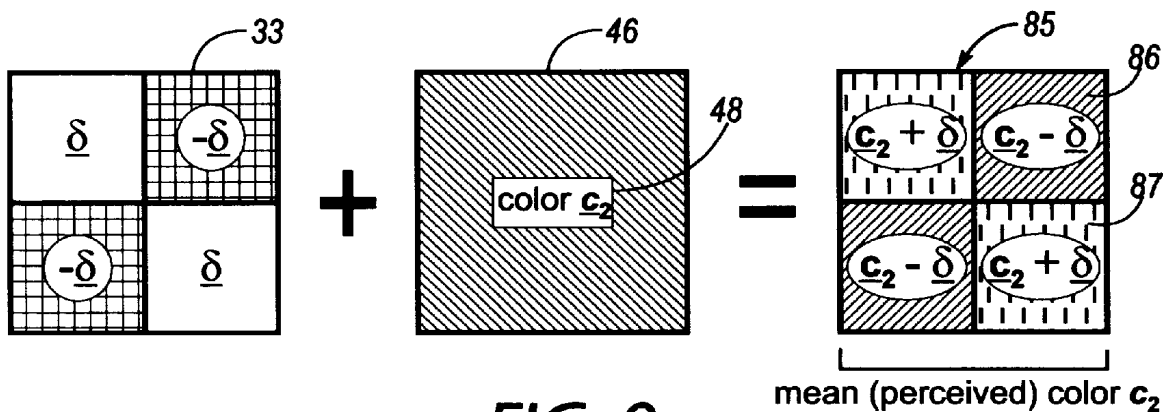

FIG. 9

Explore Litigation Insights

Docket Alarm provides insights to develop a more informed litigation strategy and the peace of mind of knowing you're on top of things.

Real-Time Litigation Alerts



Keep your litigation team up-to-date with **real-time alerts** and advanced team management tools built for the enterprise, all while greatly reducing PACER spend.

Our comprehensive service means we can handle Federal, State, and Administrative courts across the country.

Advanced Docket Research



With over 230 million records, Docket Alarm's cloud-native docket research platform finds what other services can't. Coverage includes Federal, State, plus PTAB, TTAB, ITC and NLRB decisions, all in one place.

Identify arguments that have been successful in the past with full text, pinpoint searching. Link to case law cited within any court document via Fastcase.

Analytics At Your Fingertips



Learn what happened the last time a particular judge, opposing counsel or company faced cases similar to yours.

Advanced out-of-the-box PTAB and TTAB analytics are always at your fingertips.

API

Docket Alarm offers a powerful API (application programming interface) to developers that want to integrate case filings into their apps.

LAW FIRMS

Build custom dashboards for your attorneys and clients with live data direct from the court.

Automate many repetitive legal tasks like conflict checks, document management, and marketing.

FINANCIAL INSTITUTIONS

Litigation and bankruptcy checks for companies and debtors.

E-DISCOVERY AND LEGAL VENDORS

Sync your system to PACER to automate legal marketing.