



(51) International Patent Classification:  
A61B 5/00 (2006.01)

(21) International Application Number:  
PCT/IB2010/054858

(22) International Filing Date:  
27 October 2010 (27.10.2010)

(25) Filing Language: English

(26) Publication Language: English

(30) Priority Data:  
09174732.9 2 November 2009 (02.11.2009) EP

(71) Applicant (for all designated States except US): **KONINKLIJKE PHILIPS ELECTRONICS N.V.** [NL/NL]; Groenewoudseweg 1, NL-5621 BA Eindhoven (NL).

(72) Inventors; and

(75) Inventors/Applicants (for US only): **ACKERMANS, Paul, Anton, Josef** [NL/NL]; c/o High Tech Campus Building 44, NL-5656 AE Eindhoven (NL). **KASSIES, Roelf** [NL/NL]; c/o High Tech Campus Building 44, NL-5656 AE Eindhoven (NL).

(74) Agents: **VAN VELZEN, Maaïke, M.** et al.; High Tech Campus, Building 44, NL-5656 AE Eindhoven (NL).

(81) Designated States (unless otherwise indicated, for every kind of national protection available): AE, AG, AL, AM, AO, AT, AU, AZ, BA, BB, BG, BH, BR, BW, BY, BZ, CA, CH, CL, CN, CO, CR, CU, CZ, DE, DK, DM, DO, DZ, EC, EE, EG, ES, FI, GB, GD, GE, GH, GM, GT, HN, HR, HU, ID, IL, IN, IS, JP, KE, KG, KM, KN, KP, KR, KZ, LA, LC, LK, LR, LS, LT, LU, LY, MA, MD, ME, MG, MK, MN, MW, MX, MY, MZ, NA, NG, NI, NO, NZ, OM, PE, PG, PH, PL, PT, RO, RS, RU, SC, SD, SE, SG, SK, SL, SM, ST, SV, SY, TH, TJ, TM, TN, TR, TT, TZ, UA, UG, US, UZ, VC, VN, ZA, ZM, ZW.

(84) Designated States (unless otherwise indicated, for every kind of regional protection available): ARIPO (BW, GH, GM, KE, LR, LS, MW, MZ, NA, SD, SL, SZ, TZ, UG, ZM, ZW), Eurasian (AM, AZ, BY, KG, KZ, MD, RU, TJ, TM), European (AL, AT, BE, BG, CH, CY, CZ, DE, DK, EE, ES, FI, FR, GB, GR, HR, HU, IE, IS, IT, LT, LU, LV, MC, MK, MT, NL, NO, PL, PT, RO, RS, SE, SI, SK, SM, TR), OAPI (BF, BJ, CF, CG, CI, CM, GA, GN, GQ, GW, ML, MR, NE, SN, TD, TG).

**Declarations under Rule 4.17:**

— as to applicant's entitlement to apply for and be granted a patent (Rule 4.17(ii))

[Continued on next page]

(54) Title: MEDICAL OPTICAL SENSOR

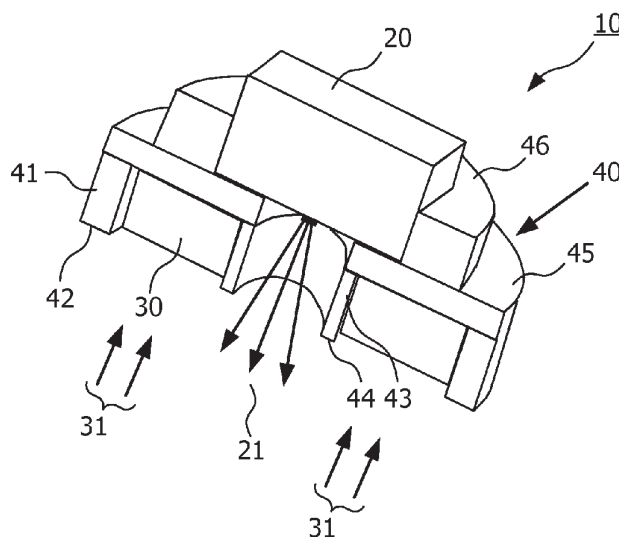

FIG. 1

(57) Abstract: The medical optical sensor (10) comprises at least one light emitter (20) for emitting light (21) directed to a part of the skin (50) of a patient and at least one photo-detector (30) for detecting light (31) reflected from the skin (50). A housing (40) for carrying the at least one light emitter (20) and the at least one photo-detector (30) is provided, where the housing (40) has a contact area with the skin (50). The at least one light emitter (20) is positioned within the housing (40) such that emitted light (21) impinges on the skin (50) in a central part of the contact area. The at least one photo-detector (30) is positioned in a peripheral part of the housing (40) such that light reflected (31) from the skin (50) to the outer part of the contact area is detectable by the at least one photo-detector (30).

WO 2011/051888 A2



---

**Published:**

- *without international search report and to be republished upon receipt of that report (Rule 48.2(g))*

Medical optical sensor

#### FIELD OF THE INVENTION

The invention relates to the field of medical sensors, and in particular to the field of medical optical sensors and systems that make use of one or more of these sensors. The invention further relates to methods for measuring the blood oxygenation level by using  
5 these sensors.

#### BACKGROUND OF THE INVENTION

Optical sensors are widely used to determine physiological parameters of patients in medical care. The non-invasive measurement of the oxygen saturation in arterial  
10 blood, also called pulse oximetry, is an application of optical medical sensors of particular importance. In pulse oximeters the oxygen saturation in arterial blood ( $SpO_2$ ), sometimes also referred to as blood oxygenation level, is determined by measuring the absorption of light caused by oxy- ( $HbO_2$ ) and deoxyhemoglobin (HHb). Usually, the absorption is measured at two different wavelengths where the extinction coefficients of  $HbO_2$  and HHb differ  
15 significantly, for example at wavelengths of 660 nanometers (nm) and 940 nm. In addition to measuring the oxygenation level of blood, pulse oximeters also provide a pulse signal for determining a heart rate of a patient.

The light emitter and photo-detector that are used as the light source and the light detector in a pulse oximeter can either be placed opposite of each other for measuring  
20 the transmission of light through the skin tissue, or adjacent to each other, measuring the diffuse reflection of light from the skin tissue. Suitable measurement locations are for example finger tips, toes, earlobes and the forehead.

With an increasing integration level of signal processing electronics and the recent advances in wireless transmission technology, wearable pulse oximeters are available  
25 that allow measurements to be taken while a patient is free to move around. An example of a wearable pulse oximeter is disclosed in the document US 2009/0240125 A1. The document describes a pulse oximeter that uses an optical sensor of the transmission type. An integrated circuit including signal processing elements required to convert the detected light signals into a pulse oximetry measurement is integrated into a carriage housing of the optical sensor.

In optical measurements on the skin, motion artifacts are a serious point of concern. Movements of a patient could lead to a movement of the sensor with respect to the skin, which, in turn, leads to a change in the optical coupling between the sensor and the skin. Sensor movements can also lead to pressure variations between the sensor and the skin,  
5 which could cause perfusion variations in the skin underneath the sensor, resulting in signal artifacts. Furthermore, the signal quality is inherently position sensitive for physiological reasons, for example due to the small size of blood vessels.

It would therefore be advantageous to provide for medical optical sensors and medical optical sensor systems that are less sensitive to motion artifacts.

10

#### SUMMARY OF THE INVENTION

The present application contemplates a medical optical sensor, a medical optical sensor unit, a medical optical sensor system, and a method of measuring the blood oxygenation level with a medical optical sensor address the abovementioned objects.

15

According to the invention, a medical optical sensor comprises at least one light emitter for emitting light directed to a part of the skin of a patient and at least one photo-detector for detecting light reflected from the skin. A housing for carrying the at least one light emitter and the at least one photo-detector is provided, where the housing has a contact area with the skin. The at least one light emitter is positioned within the housing such that  
20 emitted light impinges on the skin in a central part of the contact area. The at least one photo-detector is positioned in a peripheral part of the housing such that light reflected from the skin to the outer part of the contact area is detectable by the at least one photo-detector. This way, a compact and lightweight sensor can be built.

In a preferred embodiment, the housing comprises an outer ring and an inner  
25 ring. Both rings are concentric to each other. The outer ring has a rim that defines the outer perimeter of the contact area with the skin. The inner ring has a rim that defines the perimeter of the central part of the contact area with the skin. The housing further comprises a base plate for supporting the rings at a side of the rings opposite of the respective rims and wherein the at least one photo-detector is mounted between the outer ring and the inner ring.  
30 This way, the light emitter and the photo-detector are arranged concentric to each other in a compact way that allows obtaining a high signal quality.

Further according to the invention, a medical optical sensor unit comprises a plurality of sensors as described above, which are arranged in form of a matrix and are

connected to each other by web members, such that the sensors and the web members form a web-like structure with openings.

Further according to the invention, a medical optical sensor system comprises at least one sensor as described above or at least one sensor unit as described above. The  
5 medical optical sensor system furthermore comprises a control unit for operating the sensor or the sensor unit. Flexible electrical connectors are present for connecting the sensor or the sensor unit with the control unit.

Further according to the invention, a method of measuring the blood oxygen level with a medical optical sensor comprises the following steps. Light is emitted by at least  
10 one light emitter and directed to a part of a patient's skin. The light is then reflected by the patient's skin and received by at least one photo-detector. Electrical signals from the at least one photo-detector are processed in order to determine an oximetry value.

The basic idea behind all mentioned aspects of the invention is that mechanical forces acting on the sensor which lead to pressure variations between the sensor  
15 and the skin or even to a dislocation of the sensor with respect to the skin are minimized. One type of force acting on the sensor is inertial force. Inertial forces result from an acceleration of the inert mass of the sensor. Acceleration of the sensor is unavoidable if a patient moves. For a given acceleration, the force acting on the sensor is proportional to the mass of the sensor. The small and compact design of the medical optical sensor according to the  
20 invention allows building a lightweight sensor that accordingly only experiences small acceleration forces and is well suited for wearable systems. Furthermore, the separation of the electronic control unit and the sensor in the medical optical sensor system according to the invention also minimizes the weight of the sensor and thus the acceleration forces that act on the sensor. A coupling of a plurality of sensors to form a sensor unit according to the  
25 invention opens the possibility to have a lightweight sensor arrangement with a low position sensitivity, i.e. the performance of the sensor arrangement is less influenced by the position of the sensor on the patient.

Another type of force acting on the sensor arises from the electrical connections use for operating the sensor. The mechanical decoupling of the sensor from the  
30 electronic control unit due to the flexible electrical connection furthermore minimizes the forces acting on the sensor.

Advantageous embodiments are provided in the respective dependent claims. Still further advantages and benefits of the present invention will become apparent from and

# Explore Litigation Insights

Docket Alarm provides insights to develop a more informed litigation strategy and the peace of mind of knowing you're on top of things.

## Real-Time Litigation Alerts



Keep your litigation team up-to-date with **real-time alerts** and advanced team management tools built for the enterprise, all while greatly reducing PACER spend.

Our comprehensive service means we can handle Federal, State, and Administrative courts across the country.

## Advanced Docket Research



With over 230 million records, Docket Alarm's cloud-native docket research platform finds what other services can't. Coverage includes Federal, State, plus PTAB, TTAB, ITC and NLRB decisions, all in one place.

Identify arguments that have been successful in the past with full text, pinpoint searching. Link to case law cited within any court document via Fastcase.

## Analytics At Your Fingertips



Learn what happened the last time a particular judge, opposing counsel or company faced cases similar to yours.

Advanced out-of-the-box PTAB and TTAB analytics are always at your fingertips.

## API

Docket Alarm offers a powerful API (application programming interface) to developers that want to integrate case filings into their apps.

## LAW FIRMS

Build custom dashboards for your attorneys and clients with live data direct from the court.

Automate many repetitive legal tasks like conflict checks, document management, and marketing.

## FINANCIAL INSTITUTIONS

Litigation and bankruptcy checks for companies and debtors.

## E-DISCOVERY AND LEGAL VENDORS

Sync your system to PACER to automate legal marketing.