



US006483976B2

(12) **United States Patent**  
**Shie et al.**

(10) **Patent No.:** **US 6,483,976 B2**  
(45) **Date of Patent:** **Nov. 19, 2002**

(54) **OPTICAL ELEMENT HAVING AN INTEGRAL SURFACE DIFFUSER**

(75) Inventors: **Rick L. Shie**, Westlake Village, CA (US); **Jeffrey A. Laine**, Redondo Beach, CA (US); **Gajendra D. Savant**, Torrance, CA (US); **Tomasz P. Jansson**, Torrance, CA (US)

(73) Assignee: **Physical Optics Corporation**, Torrance, CA (US)

(\* ) Notice: Subject to any disclaimer, the term of this patent is extended or adjusted under 35 U.S.C. 154(b) by 0 days.

(21) Appl. No.: **09/851,815**

(22) Filed: **May 9, 2001**

(65) **Prior Publication Data**

US 2001/0017970 A1 Aug. 30, 2001

**Related U.S. Application Data**

(62) Division of application No. 09/139,488, filed on Aug. 25, 1998, now Pat. No. 6,266,476.

(51) **Int. Cl.<sup>7</sup>** ..... **G02B 6/00**

(52) **U.S. Cl.** ..... **385/133; 385/146; 359/566**

(58) **Field of Search** ..... 385/146-147, 385/133, 141; 359/443, 566, 707, 742

(56) **References Cited**

**U.S. PATENT DOCUMENTS**

5,339,179 A \* 8/1994 Rudisill et al. .... 359/49  
5,854,872 A \* 12/1998 Tai ..... 385/133  
6,266,476 B1 \* 7/2001 Shie et al. .... 385/147

\* cited by examiner

*Primary Examiner*—Ellen E. Kim

(74) *Attorney, Agent, or Firm*—Nilles & Nilles; Leonard Tachner

(57) **ABSTRACT**

A monolithic element has a substrate body and at least one macro-optical characteristic integral in a first portion of the optical element. A plurality of surface micro-structures are integral in a portion of the optical element. The micro-structures are designed to homogenize light passing through the optical element to produce a predetermined pattern of smoothly varying, non-discontinuous light exiting the optical element. The light exiting the optical element is therefore altered according to both the macro-optical characteristic of the optical element as well as the homogenizing characteristics of the micro-structures.

**15 Claims, 3 Drawing Sheets**

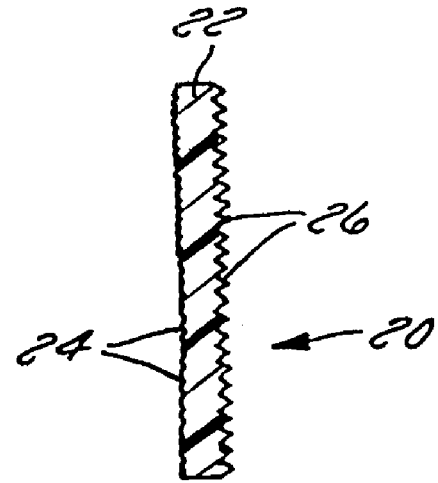
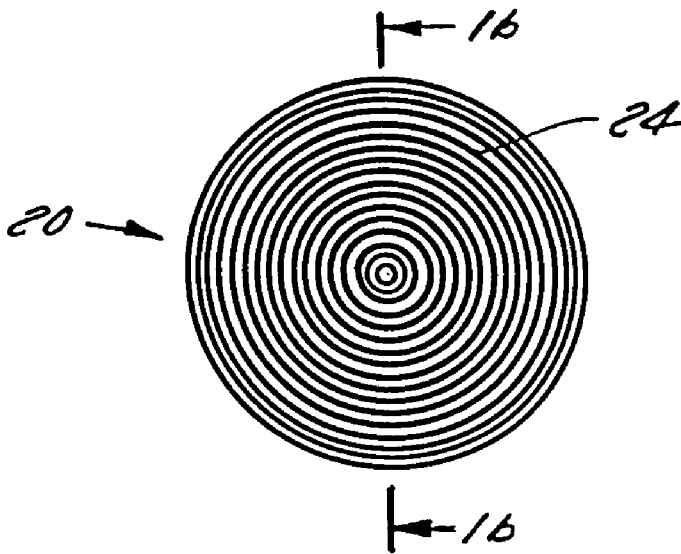

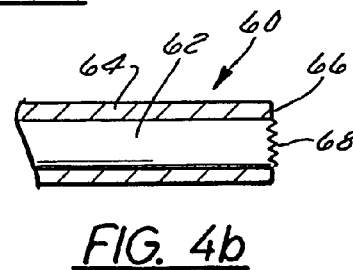
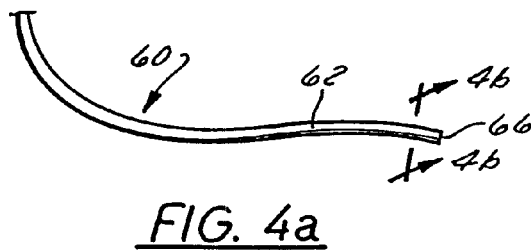
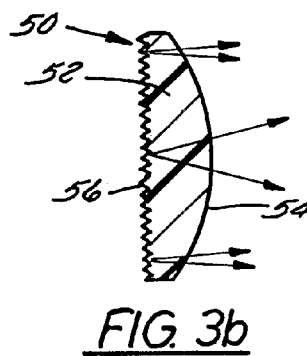
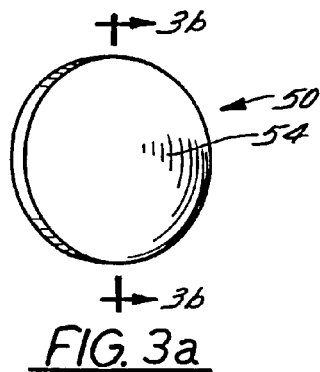
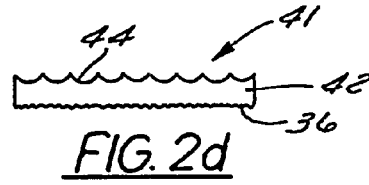
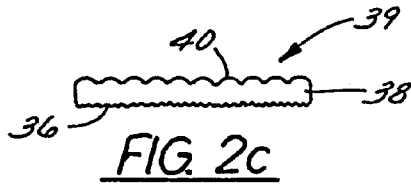
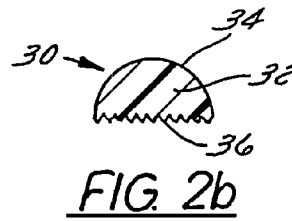
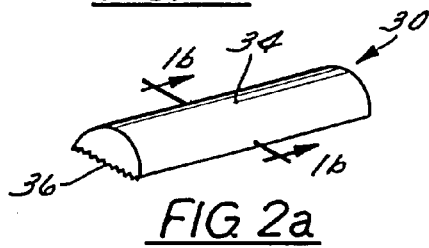
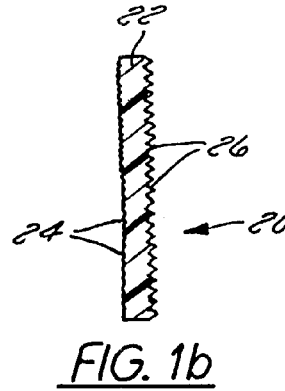
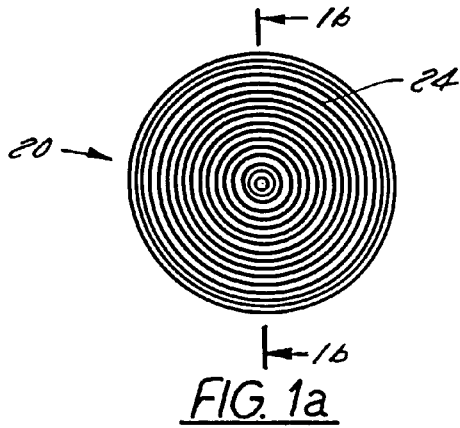

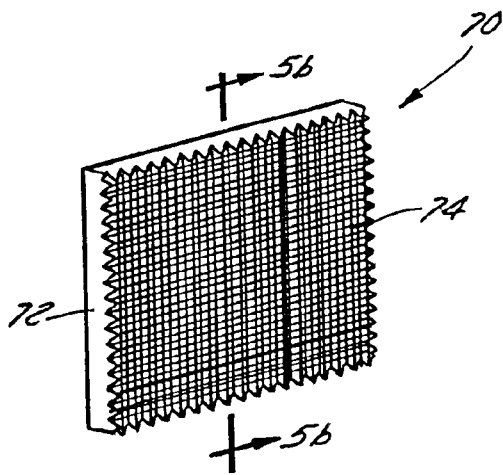

FIG. 5a

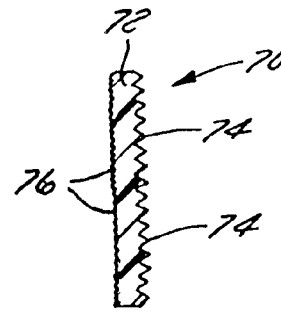

FIG. 5b

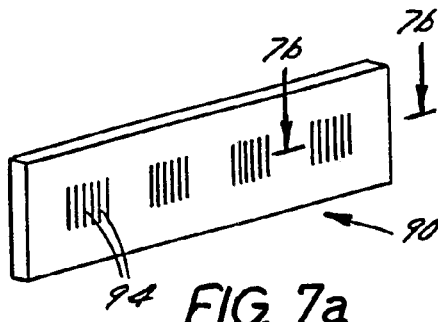

FIG. 7a

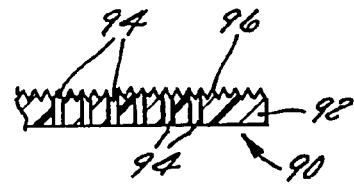

FIG. 7b

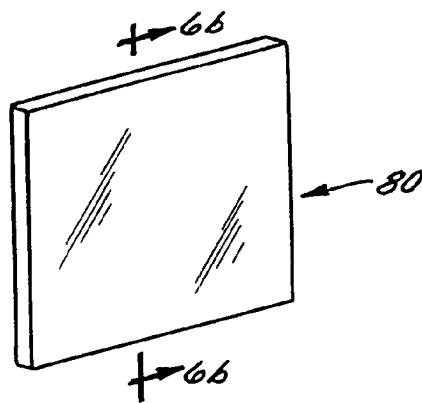

FIG. 6a

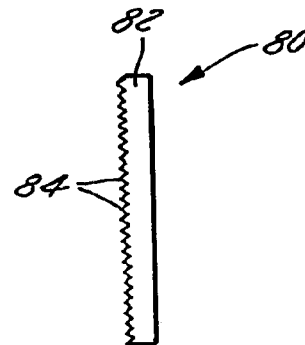

FIG. 6b

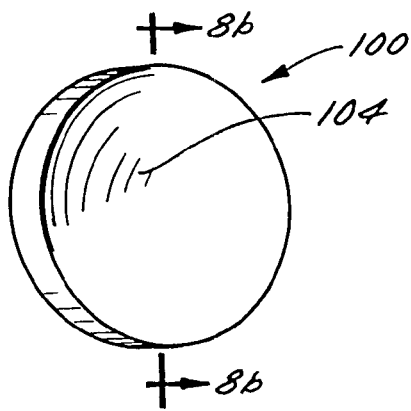

FIG. 8a

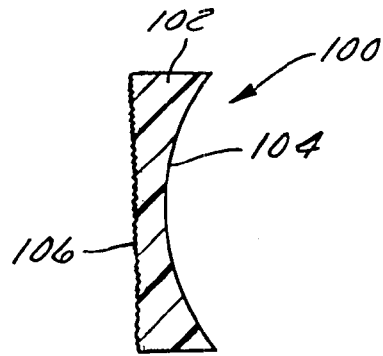

FIG. 8b

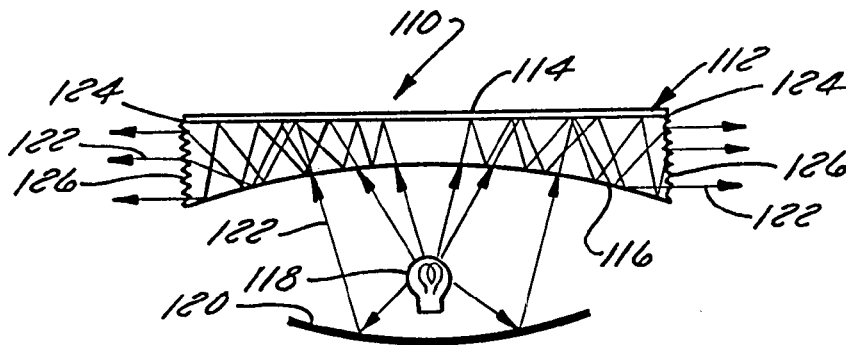

FIG. 9

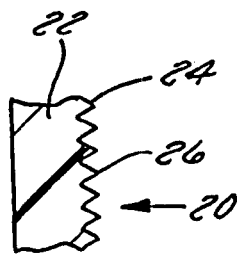

FIG. 10a

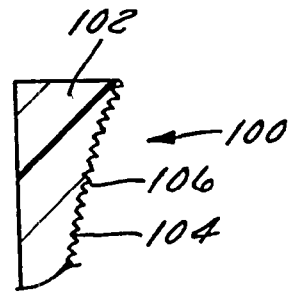

FIG. 10b

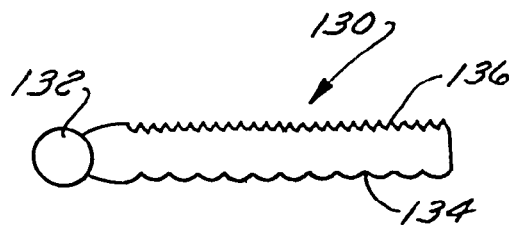

FIG. 11

**OPTICAL ELEMENT HAVING AN INTEGRAL SURFACE DIFFUSER**

The present application is a divisional application of U.S. patent application Ser. No. 09/139,488, filed Aug. 25, 1998, now patented with U.S. Pat. No. 6,266,476.

**BACKGROUND OF THE INVENTION**

1. Field of the Invention

The present invention relates generally to the field of optics, and more particularly to various optical elements incorporating an integral surface diffuser as a portion of the optical element.

2. Description of the Related Art

There are many types of optical elements useful for an endless number of current and new applications. These optical elements are placed in a beam or path of light to change the characteristics of the light passing through the optical elements. Such optical elements may be as simple as a conventional cylindrical lens where a beam of light entering the lens remains unaffected in its width and is spread by the cylindrical lens contour in a direction perpendicular to its width. An example of another optical element is a transparent medium having a flat surface on one side and a concave or convex surface on the other side which changes the characteristics of light passing through the lens. Such lenses are commonly used for eyeglasses, magnifying glasses, film projectors and similar objects.

Other types of optical elements are known and may include Fresnel structures, grating structures, filters, Total internal reflection (TIR) structures, nonlinear optical elements such as GRIN lenses, prismatic structures, polarizers, pillow optic formations, fiber optic cables and other types of optical wave guides. All of these structures receive a light input from a light source and transmit or reflect the light through the structure or element and then permit the light to exit from the structure or element in a somewhat altered state. All of these types of optical elements either transmit, reflect, diffract, refract, or filter out certain wavelengths of the light as it exits the structure or element.

Each of these optical elements receives light from a light source having particular characteristics defined by the properties of the light source and then alter the light propagating through the optical element. However, none of these optical elements is capable of improving the optical qualities of the light in a manner which evens or smoothes out the light by eliminating high-intensity spots and low-intensity spots within the source. By evenly diffusing the light traveling in or through the optical element the output is made smooth and non-discontinuous. Additionally, none of these types of optical elements is capable of substantially reducing or eliminating scatter of light and directing substantially all or most of the light photons in a particular desired direction, pattern, or envelope. Virtually all of these known optical elements merely perform a particular optical function as light passes through or reflects off of the element.

For example, a fiber optic cable is designed to take in light energy at one end and via the predetermined refractive index of the fiber materials (core and cladding) continually and internally reflects the light as it passes through the fiber so that essentially all the light exits the fiber optic cable in substantially the same form in which it was received (ignoring modal variations). Convex lenses used in such objects as eyeglasses and projector lenses (which use multiple lenses) slightly bend the light as it enters one side of the lens according to the amount of curvature or shape of the

lens or lenses and the materials utilized to manufacture the lens. A Fresnel lens includes a plurality of Fresnel structures provided on a surface of the lens which bend or refract the light in order to collimate or focus light passing through the lens. Many other optical elements are available which perform a particular optical function on light. These optical elements are not capable of smoothing out or "homogenizing" the light intensity variations exiting the optical element or directing substantially all of the light in a particular direction and in a particular shape, envelope, or pattern. Consequently, in prior art optical elements, a significant amount of light is lost or wasted.

Diffusers have been applied as a separate layer to optical elements in order to add both light diffusing and directing characteristics. In such a construction, a laminate is formed including a sheet or a layer of diffuser material applied or adhered to a surface of an optical element, such as for example, a Fresnel lens. One problem with such a construction is that the sheet material is not very durable and is easily damaged, scratched or otherwise deformed during use. Another problem is that the diffuser sheet metal may simply peel away from the optical element over time or under certain conditions. Another even more critical problem with such a laminate construction is that the mating surfaces between the two portions of the laminate create an interface which refracts or reflects a portion of light entering the optical element. This Fresnel reflection causes a minimum loss of 4% of the incident light at each mating surface which therefore does not pass through the diffuser and optical element or is otherwise altered in an undesirable manner. A further problem with such a construction is that an index matching optical grade epoxy or adhesive must be used in order to adhere the two parts of the laminate together. The optical grade epoxy permits passage of light through itself but creates an additional layer or refractive surface at each contact point, and hence additional Fresnel losses, both between the diffuser layer and the epoxy and between the optical element and the epoxy. The epoxy layer also adds cost to the laminate construction as well as manufacturing complexity. Another problem with the epoxy is that there may be instances where the epoxy is not in complete contact with one surface of the laminate or has air bubbles between the epoxy and one of the laminate layers or within the epoxy itself. Such irregularities cause further problems (i.e., scattering) with light passing within the laminate optical element. All the above problems greatly reduce the performance and desirability of laminated optical elements.

The assignee of the present invention has invented several ways of forming a plurality of surface micro-structures in various materials to form a surface diffuser on such materials. These methods are described in a number of issued patents and co-pending patent applications listed below. Many of these methods involve creating a master diffuser by exposing a photoresist material to a source of light and then replicating this master diffuser into one or more submasters of a more durable nature. There are also other methods of making replicas of a master diffuser which contain the optical features in the master. With some of these methods, the master diffuser is initially created optically. With others, it is created mechanically. Submasters are created from these master diffusers utilizing a number of methods whereby the master diffuser surface is replicated into a submaster surface. These other methods are described in one or more pending U.S. applications, referenced below, which are assigned to the assignee of the present invention.

Other commonly assigned U.S. patents and pending applications disclose related methods for making and

# Explore Litigation Insights

Docket Alarm provides insights to develop a more informed litigation strategy and the peace of mind of knowing you're on top of things.

## Real-Time Litigation Alerts



Keep your litigation team up-to-date with **real-time alerts** and advanced team management tools built for the enterprise, all while greatly reducing PACER spend.

Our comprehensive service means we can handle Federal, State, and Administrative courts across the country.

## Advanced Docket Research



With over 230 million records, Docket Alarm's cloud-native docket research platform finds what other services can't. Coverage includes Federal, State, plus PTAB, TTAB, ITC and NLRB decisions, all in one place.

Identify arguments that have been successful in the past with full text, pinpoint searching. Link to case law cited within any court document via Fastcase.

## Analytics At Your Fingertips



Learn what happened the last time a particular judge, opposing counsel or company faced cases similar to yours.

Advanced out-of-the-box PTAB and TTAB analytics are always at your fingertips.

## API

Docket Alarm offers a powerful API (application programming interface) to developers that want to integrate case filings into their apps.

## LAW FIRMS

Build custom dashboards for your attorneys and clients with live data direct from the court.

Automate many repetitive legal tasks like conflict checks, document management, and marketing.

## FINANCIAL INSTITUTIONS

Litigation and bankruptcy checks for companies and debtors.

## E-DISCOVERY AND LEGAL VENDORS

Sync your system to PACER to automate legal marketing.