



US 20090097129A1

(19) **United States**

(12) **Patent Application Publication**
NAITO et al.

(10) **Pub. No.: US 2009/0097129 A1**

(43) **Pub. Date: Apr. 16, 2009**

(54) **OPTICAL ARTICLE AND PROCESS FOR PRODUCING OPTICAL ARTICLE**

Aug. 12, 2008 (JP) 2008-208121

Publication Classification

(75) Inventors: **Shuji NAITO**, Inashi (JP); **Yosuke SUGIHARA**, Suwashi (JP)

(51) **Int. Cl.**
G02B 1/04 (2006.01)
B32B 5/22 (2006.01)
B32B 18/00 (2006.01)
B32B 23/08 (2006.01)
B32B 27/06 (2006.01)
B29D 11/00 (2006.01)

Correspondence Address:
HOGAN & HARTSON L.L.P.
1999 AVENUE OF THE STARS, SUITE 1400
LOS ANGELES, CA 90067 (US)

(73) Assignee: **SEIKO EPSON CORPORATION**, Tokyo (JP)

(52) **U.S. Cl.** **359/653**; 428/425.9; 428/419; 428/212; 428/218; 428/414; 428/404; 427/164

(21) Appl. No.: **12/247,073**

(57) **ABSTRACT**

(22) Filed: **Oct. 7, 2008**

An optical article includes a plastic substrate, wherein a primer layer and a hard coat layer are formed on a surface of the plastic substrate, and the primer layer is formed from a coating composition containing the following components (A) to (C): (A) a polyurethane resin; (B) metal oxide fine particles; and (C) an organosilicon compound.

(30) **Foreign Application Priority Data**

Oct. 15, 2007 (JP) 2007-267774
Jan. 28, 2008 (JP) 2008-016342

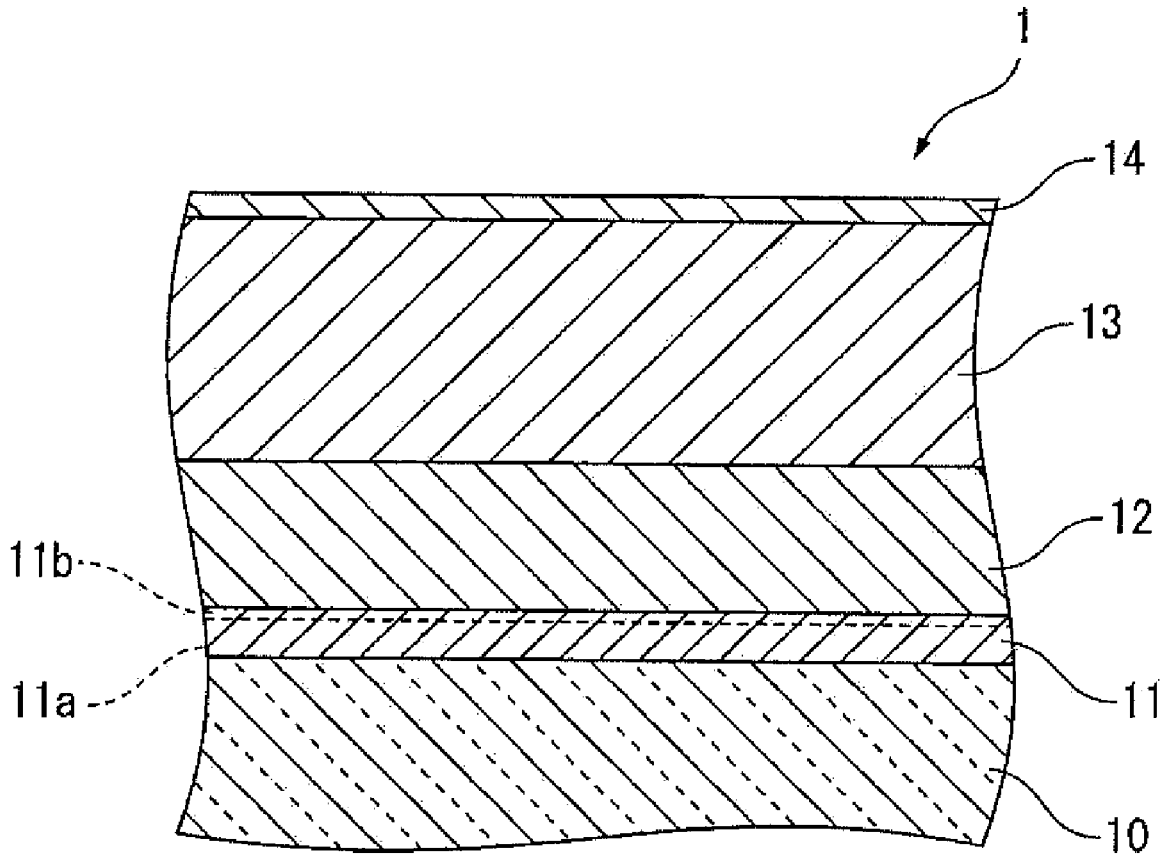

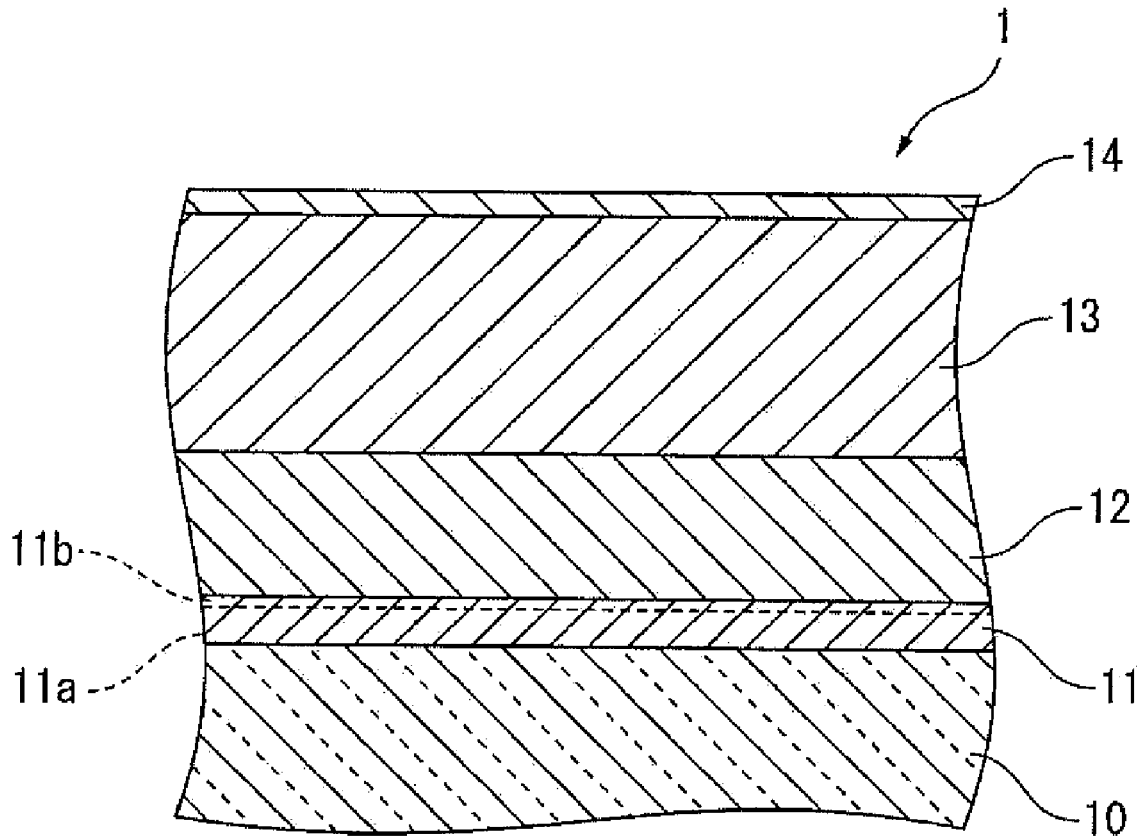

FIG. 1

OPTICAL ARTICLE AND PROCESS FOR PRODUCING OPTICAL ARTICLE

BACKGROUND

[0001] 1. Technical Field

[0002] The present invention relates to an optical article to be used as a plastic lens for spectacles, cameras, and the like, and a process for producing an optical article.

[0003] 2. Related Art

[0004] Plastic lenses are lightweight and excellent in moldability, processability, dyeability, etc. and less likely to crack and have high safety as compared with glass lenses. Therefore, their use has rapidly spread in the field of lenses for spectacles and they make up a large portion thereof. Further, recently, in order to meet an additional demand of reducing the thickness and weight, a material having a high refractive index such as a thiourethane resin or an episulfide resin has been developed. For example, a process for producing an episulfide resin having a very high refractive index by polymerization of a compound having an epithio group (an episulfide compound) in the presence of sulfur has been proposed (see JP-A-2004-002712 and JP-A-2005-281527). Such an episulfide resin can easily exhibit a high refractive index of 1.7 or higher and is effective in reducing the thickness of lenses for spectacles.

[0005] On the other hand, when the refractive index of a lens substrate is increased, a primer layer and a hard coat layer should have a refractive index equal to that of the lens substrate for preventing the occurrence of interference fringe. For example, in general, any of various metal oxides is incorporated in the hard coat layer as a filler thereby increasing the refractive index. As the metal oxide, fine particles of a simple substance such as titanium oxide, zirconium oxide, antimony oxide or tin oxide or composite fine particles thereof are used. However, such a metal oxide is generally poor in light resistance and tends to be colored. Therefore, from the viewpoint of transparency and stability in the visible light range and the like, titanium oxide is mainly used. However, titanium oxide has a property of exhibiting a photocatalytic action under ultraviolet radiation. Therefore, when titanium oxide is used as a filler in the hard coat layer, it decomposes a binder component composed of an organic resin therearound, and the coat layer is often peeled off. As one of the measures for this problem, it is often the case that anatase-type titanium oxide which is likely to exhibit a photocatalytic action, but rutile-type titanium oxide which exhibits a relatively less photocatalytic action is adopted as titanium oxide (for example, see JP-A-2007-102096).

[0006] However, such rutile-type titanium oxide do not completely have a photocatalytic action, and an attempt that the photocatalytic action is reduced by coating the surface thereof with an insulating material such as silicon dioxide has also been made, but is not sufficient. Accordingly, when light resistance is considered, a method of increasing the content of rutile-type titanium oxide in the coating layer could not simply increase the refractive index of a hard coat layer or a primer layer, and when a lens substrate has a refractive index of 1.7 or higher, the occurrence of interference fringe could not completely be prevented. Further, a problem has also arisen that the impact resistance is decreased as the thickness of a lens substrate is reduced.

SUMMARY

primer layer, and a hard coat layer, causes almost no interference fringe, and is excellent in impact resistance, and a process for producing an optical article.

[0008] A first aspect of the invention is directed to an optical article composed of a plastic substrate, wherein a primer layer and a hard coat layer are formed on a surface of the plastic substrate, and the primer layer is formed from a coating composition containing the following components (A) to (C):

[0009] (A) a polyurethane resin;

[0010] (B) metal oxide fine particles; and

[0011] (C) an organosilicon compound.

[0012] In accordance with the aspect of the invention, as the coating composition for forming the primer layer, not only a polyurethane resin and metal oxide fine particles are used, but also an organosilicon compound is used in combination. Therefore, a space portion in the primer layer is filled with the organosilicon compound (component (C)), and thus the density of the entire primer layer is increased. Accordingly, even without using titanium oxide, or by incorporating only a small amount of titanium oxide therein, the refractive index of the primer layer can be improved, and the occurrence of interference fringe can be prevented. Further, when the used amount of titanium oxide is decreased, the photocatalytic action is also decreased, and the light resistance is improved. Further, a polyurethane resin is contained in the primer layer, therefore the impact resistance is also superior.

[0013] As the plastic substrate, a plastic substrate which is obtained by polymerizing and curing a polymerizable composition containing an episulfide compound as a main component, and has a refractive index of 1.7 or higher is preferred. Because the plastic substrate has a high refractive index of 1.7 or higher, the reduction of the thickness of the substrate for an optical article is easy, and further, an optical article having few interference fringes can be easily provided.

[0014] It is preferred that the average particle diameters of the component (A) and the component (B) in the coating composition are from 5 to 50 nm, respectively, and the average particle diameter of the component (C) is 5 nm.

[0015] In accordance with this configuration, the average particle diameters of the component (A) and the component (B), and the average particle diameter of the component (C) each fall within a predetermined range, and therefore, the refractive index of the primer layer can be further improved. As a result, even when a plastic substrate having a high refractive index of 1.7 or higher is used, the occurrence of interference fringe can be effectively prevented.

[0016] The mechanism of this action is presumed as follows. In the absence of the component (C), even when the refractive index of metal oxide fine particles as the component (B) is increased or the ratio thereof is increased, the refractive index of the primer layer is not improved so much. Therefore, as the mechanism of action for achieving the above-mentioned effect, because the average particle diameters of the above-mentioned respective particles fall within a predetermined range, the component (C) enters a space (a space portion) formed by the particles composed of the component (A) and the particles composed of the component (B), resulting in forming a dense layer at such a portion and contributing to the improvement of refractive index. The average particle diameters of the above-mentioned respective particles can be obtained by a light scattering method.

the plastic substrate and has a refractive index which decreases in the direction away from the plastic substrate; a second layer which is in contact with the first layer and has a refractive index not higher than that of the surface layer of the first layer; and a hard coat layer which is in contact with the second layer and has a refractive index lower than that of the plastic substrate.

[0018] In accordance with this configuration, the optical article basically includes a plastic substrate, a hard coat layer, and first and second layers, both of which are sandwiched between the plastic substrate and the hard coat layer. Therefore, the first and second layers can be allowed to serve as a primer layer, that is, a function including adhesion and impact resistance. Further, by allowing the first layer having a refractive index which decreases in the direction away from the plastic substrate to have a function to prevent the occurrence of interference fringe through adjustment of the refractive index, the need of increasing the refractive index of the second layer can be relieved. Due to this, in the second layer, the need of increasing the ratio of metal oxide fine particles can be relieved, therefore, the second layer can sufficiently exhibit an impact absorbing function. Further, because the need of increasing the refractive index of the second layer can be relieved, the need of increasing the refractive index of the hard coat layer can also be relieved.

[0019] That is, in this optical article, by the first layer, adhesion and a function to prevent the occurrence of interference fringe through adjustment of the refractive index can mainly be imparted. By the second layer, impact resistance, that is, impact absorbing function can be mainly imparted. Further, by providing a hard coat layer which is harder than the first and second layers on the second layer, scratch resistance and abrasion resistance can be imparted. Further, because the need of increasing the refractive index of the second layer and also the need of increasing the refractive index of the hard coat layer can be relieved by the first layer, the refractive indices of the second layer and the hard coat layer to be laminated to the first layer can be lower than that of the plastic substrate. Accordingly, the constitutions of these layers, choices of compositions for forming these layers and the degree of freedom of the designing are increased. As described above, according to the aspect of the invention, the occurrence of interference fringe can be prevented, and an optical article which has high durability including impact resistance, scratch resistance, and abrasion resistance and also has a high refractive index can be provided.

[0020] It is preferred that the second layer is formed from a second material containing a urethane, ester, epoxy, acrylic or silicone organic resin and metal oxide fine particles.

[0021] In accordance with this configuration, the second layer is formed from the second material containing a urethane, ester, epoxy, acrylic, or silicone organic resin and metal oxide fine particles. Therefore, adhesion becomes more favorable. Further, among these organic resins, a urethane or ester organic resin is preferred. The second layer can be formed by, for example, a dip coating method, a spin coating method, a spray coating method or the like.

[0022] It is preferred that a first material for forming the first layer, the second material for forming the second layer and a third material for forming the hard coat layer each

contained in the first material is greater than the ratio of the metal oxide fine particles to the organic resin contained in the second material.

[0023] In accordance with this configuration, the first layer having a high refractive index in the vicinity of the plastic substrate can be obtained and also the second layer having high impact resistance can be obtained. Further, in this case, the ratio of the metal oxide fine particles to the organic resin contained in the third material may be set greater than the ratio of the metal oxide fine particles to the organic resin contained in the second material.

[0024] It is preferred that the refractive index of the primer layer decreases continuously or stepwise from the side of the plastic substrate toward the side of the hard coat layer.

[0025] In accordance with this configuration, the refractive index of the primer layer decreases continuously or stepwise from the side of the plastic substrate toward the side of the hard coat layer, therefore, the refractive index of the hard coat layer can be decreased. That is, even when the refractive index of the hard coat layer is low, a difference in the refractive index with the primer layer can be made small, therefore, the occurrence of interference fringe can be prevented.

[0026] In the past, in the case where a hard coat layer was formed on a surface of an optical article such as an optical lens, when the refractive index of a substrate was high, it was necessary that the a primer layer and the hard coat layer should have a high refractive index in response thereto. In accordance with the aspect of the invention, the refractive index of the hard coat layer should not be increased, and therefore, the degree of freedom of designing of the hard coat layer is increased.

[0027] It is preferred that a difference between the refractive index of the primer layer in the vicinity of the plastic substrate and the refractive index of the plastic substrate is 0.01 or less.

[0028] In accordance with this configuration, a difference between the refractive index of the primer layer in the vicinity of the plastic substrate and the refractive index of the plastic substrate is a predetermined value or less, therefore, the occurrence of interference fringe can be effectively prevented.

[0029] It is preferred that a difference between the refractive index of the primer layer in the vicinity of the hard coat layer and the refractive index of the hard coat layer is 0.01 or less.

[0030] In accordance with this configuration, a difference between the refractive index of the primer layer in the vicinity of the hard coat layer and the refractive index of the hard coat layer is a predetermined value or less, therefore, the occurrence of interference fringe can be effectively prevented.

[0031] It is preferred that the component (C) is an organo-silicon compound having an epoxy group.

[0032] In accordance with this configuration, the organo-silicon compound has an epoxy group, therefore, the adhesion of the primer layer to the plastic substrate and the hard coat layer is excellent. Further, the crosslink density of the primer layer is not increased too much and is appropriately controlled, therefore, the optical article is excellent in impact resistance.

[0033] It is preferred that the component (C) is an organoalkoxysilane compound and the organoalkoxysilane compound is used in the form of an unhydrolyzed monomer.

lyzed monomer, therefore, it is easily filled in a space portion in the primer layer as compared with the case where it is polymerized by hydrolysis. Accordingly, the refractive index of the primer layer is further improved, and the occurrence of interference fringe can be prevented although an episulfide plastic substrate having a refractive index of 1.7 or higher is used.

[0035] It is preferred that the ratio of the component (C) to the total components (A) to (C) is from 0.1 to 10% by mass.

[0036] In accordance with this configuration, the ratio of the organosilicon compound as the component (C) is 0.1% by mass or more, therefore, the adhesion to the plastic substrate and the hard coat layer is superior. In addition, because the ratio of the organosilicon compound is 10% by mass or less, a decrease in the refractive index and abrasion resistance is not caused. The upper limit of the component (C) is preferably 7% by mass or less; and more preferably 5% by mass or less.

[0037] It is preferred that the component (B) is metal oxide fine particles surface-treated with an organosilicon compound having an alkyl group.

[0038] In accordance with this configuration, by using a polyurethane resin and metal oxide fine particles surface-treated with an organosilicon compound having an alkyl group such as a methyl group, the compatibility between the resin component and the metal oxide fine particle component is improved in the primer layer, and as a result, the homogeneity is improved. Therefore, the occurrence of interference fringe is prevented and the impact resistance is also improved. Further, when the homogeneity of the primer layer is improved, the homogeneity of spaces to be filled with an organosilicon compound as the component (C) is also improved at the same time, and as a result, the refractive index of the primer layer is further improved and the occurrence of interference fringe can be more effectively prevented.

[0039] It is preferred that the component (B) is metal oxide fine particles containing titanium oxide having a rutile-type crystal structure as a main component.

[0040] In accordance with this configuration, metal oxide fine particles containing titanium oxide having a rutile-type crystal structure as a main component are used as the component (B), therefore, not only the refractive index of the primer layer is improved, but also the light resistance is improved. In particular, a polyurethane resin to be used as the component (A) greatly contributes to the improvement of light resistance.

[0041] It is preferred that the ratio of the component (B) to the total components (A) to (C) is from 40 to 80% by mass.

[0042] In accordance with this configuration, the ratio of the metal oxide particles as the component (B) to the total components (A) to (C) falls within a predetermined range of from 40 to 80% by mass, therefore, the refractive index of the primer layer can be sufficiently increased, and also the crosslink density of the primer layer can be appropriately maintained, and further, the hardness and impact resistance are not impaired.

[0043] It is preferred that the optical article according to an aspect of the invention is a plastic lens.

[0044] In accordance with this configuration, a substrate having a refractive index of 1.7 or higher, i.e., having a high refractive index is used, and moreover, a primer layer is formed from the above-mentioned components (A) to (C),

can be provided. Accordingly, the plastic lens according to the aspect of the invention can be widely used as a variety of thin-type optical lenses such as lenses for spectacles, lenses for cameras, lenses for telescopes, lenses for microscopes and collective lenses for steppers.

[0045] A second aspect of the invention is directed to a process for producing an optical article composed of a plastic substrate includes a substrate production step of producing a plastic substrate by polymerizing and curing a polymerizable composition; and a surface treatment step of forming a primer layer and a hard coat layer on a surface of the plastic substrate, wherein in the formation of the primer layer in the surface treatment step, a coating composition containing the following components (A) to (C) is used:

[0046] (A) a polyurethane resin;

[0047] (B) metal oxide fine particles; and

[0048] (C) an organosilicon compound.

[0049] In accordance with the aspect of the invention, a plastic substrate is produced by polymerizing and curing a polymerizable composition, therefore, a substrate having a different refractive index can be easily obtained. For example, when a polymerizable composition containing an episulfide compound as a main component is used, a substrate having a high refractive index of 1.7 or higher can be easily obtained. Further, because the production process includes a surface treatment step of forming a given primer layer and hard coat layer, an optical article which has few interference fringes and is excellent in scratch resistance and impact resistance can easily be produced.

BRIEF DESCRIPTION OF THE DRAWING

[0050] The invention will be described with reference to the accompanying drawing, wherein like numbers reference like elements.

[0051] The FIG. 1 is a view schematically showing a plastic lens as an optical article according to a second embodiment of the present invention.

DESCRIPTION OF EXEMPLARY EMBODIMENTS

[0052] Hereinafter, embodiments of an optical article and a process for producing an optical article of the present invention will be described in detail.

First Embodiment

[0053] An optical article of this embodiment is a plastic lens for spectacles and has a plastic lens substrate (hereinafter also referred to as merely a "lens substrate"), a primer layer formed on a surface of the lens substrate and a hard coat layer formed on the upper surface of the primer layer. Further, in the plastic lens of this embodiment, further an antireflection layer is formed on the upper surface of the hard coat layer. Hereinafter, the lens substrate, primer layer, hard coat layer and antireflection layer will be described.

1. Lens Substrate

[0054] The lens substrate is not particularly limited as long as it is a plastic resin, however, in light of reduction of the thickness of a lens for spectacles or for obtaining a difference in the refractive index with the antireflection layer formed on

Explore Litigation Insights

Docket Alarm provides insights to develop a more informed litigation strategy and the peace of mind of knowing you're on top of things.

Real-Time Litigation Alerts



Keep your litigation team up-to-date with **real-time alerts** and advanced team management tools built for the enterprise, all while greatly reducing PACER spend.

Our comprehensive service means we can handle Federal, State, and Administrative courts across the country.

Advanced Docket Research



With over 230 million records, Docket Alarm's cloud-native docket research platform finds what other services can't. Coverage includes Federal, State, plus PTAB, TTAB, ITC and NLRB decisions, all in one place.

Identify arguments that have been successful in the past with full text, pinpoint searching. Link to case law cited within any court document via Fastcase.

Analytics At Your Fingertips



Learn what happened the last time a particular judge, opposing counsel or company faced cases similar to yours.

Advanced out-of-the-box PTAB and TTAB analytics are always at your fingertips.

API

Docket Alarm offers a powerful API (application programming interface) to developers that want to integrate case filings into their apps.

LAW FIRMS

Build custom dashboards for your attorneys and clients with live data direct from the court.

Automate many repetitive legal tasks like conflict checks, document management, and marketing.

FINANCIAL INSTITUTIONS

Litigation and bankruptcy checks for companies and debtors.

E-DISCOVERY AND LEGAL VENDORS

Sync your system to PACER to automate legal marketing.