



# Patent Owner Masimo's Trial Hearing Demonstratives

*Apple Inc. v. Masimo Corp.*  
IPR2022-01291, IPR2022-01465  
U.S. Pat. No. 10,687,745

## Notes

---

- All emphases, highlighting, and annotations in exhibits and figures are added unless noted otherwise.
- Citations refer to the filing in IPR2022-01291, unless noted otherwise.
- Arguments common to both IPR2022-01291 and -01465 are cited with reference to the 1291 filing.

## Abbreviations

**POPR**

Patent Owner's Preliminary Response

**POR**

Patent Owner's Response

**Reply**

Petitioner's Reply

**Sur-Reply**

Patent Owner's Sur-Reply

**PRET**

Petitioner's Response to Expert Testimony

**SpO2**

Oxygen saturation measured by pulse oximetry

# PUBLIC SESSION

DEMONSTRATIVE EXHIBIT – NOT EVIDENCE

4

# BACKGROUND

DEMONSTRATIVE EXHIBIT – NOT EVIDENCE

5

# '745 Patent

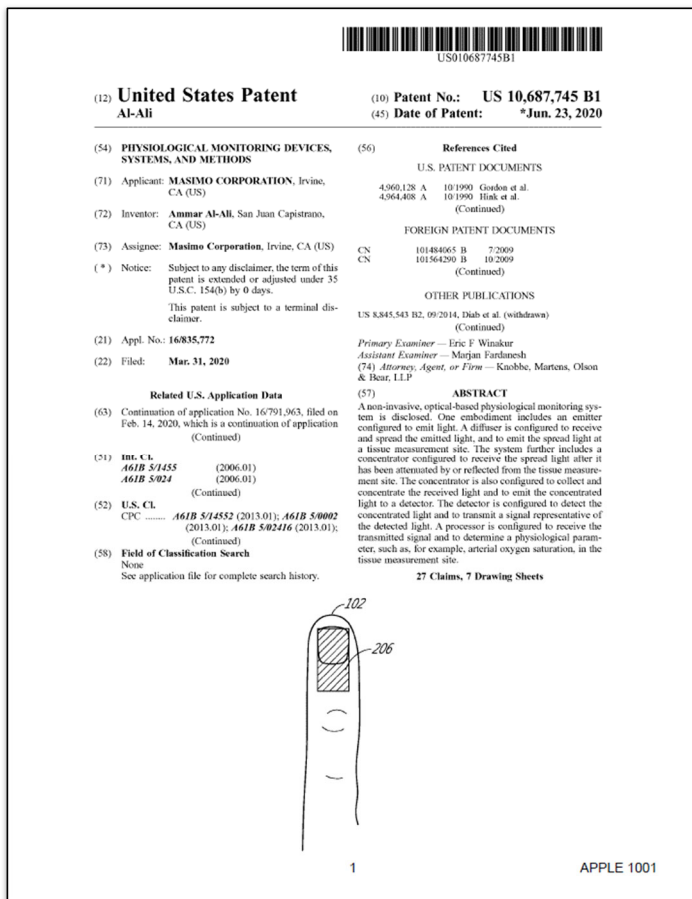

- ⊙ Result of Ammar Al-Ali's research on pulse oximetry at the wrist around 2014-2015
- ⊙ Patent discloses various enhancements that improve signals typically obscured by noise
- ⊙ Applies unconventional 3D analytical model
- ⊙ Claims novel combination of features
- ⊙ Claims 9 and 18 – oxygen saturation at the wrist

1291 POR, 7-10; EX2008, 248:24-249:8; EX1001, 5:41-7:3, 7:4-62, 8:54-9:10, 10:40-11:66, Figs. 7A-7B

DEMONSTRATIVE EXHIBIT – NOT EVIDENCE

6

## Masimo's Wrist-Worn Sensor Uses '745 Patent's Technology



# ITC Investigation 337-TA-1276

DEMONSTRATIVE EXHIBIT – NOT EVIDENCE

8



**2021**  
Masimo files ITC  
complaint against Apple  
EX1031

**June 6-10, 2022**  
ITC Hearing  
EX2008

**July 11, 2022**  
ITC post-hearing  
briefing complete  
EX2051

**July 22, 2022**  
Apple files IPR2022-01291

**August 26, 2022**  
Apple files IPR2022-01465

**January 10, 2023**  
ITC Final Initial Determination:  
Claims 9, 18, 27 not obvious  
EX1033

**October 26, 2023**  
ITC Commission Opinion affirms  
Initial Determination validity findings

2021

2022

2023

## ITC Made Key Findings

Apple also has not clearly and convincingly shown that one of ordinary skill in the art would have had a reasonable expectation of success in modifying Iwamiya to measure oxygen saturation—the record contains testimony from multiple Apple engineers expressing skepticism regarding the implementation of pulse oximetry in a wrist-worn device. *See* Tr. (Mannheimer) at 1012:12-16; CX-0299C (Waydo Dep. Tr.) at 166:4-167:5; CX-0295C (Shui Dep. Tr.) at 108:15-21.

ITC Final Initial Determination (EX1033/EX2093) at 231

ITC Final Commission Opinion (October 26, 2023) **affirmed** the January 10, 2023 Initial Determination that the '745 Patent claims are not invalid as obvious

## Petitioner's Grounds (1291)

Ground	Claims	Basis for Rejection (35 U.S.C. § 103)
1A	1, 9	Iwamiya in view of Sarantos
1B	15, 18, 20, 27	Iwamiya and Sarantos in view of Venkatraman
2A	1, 9, 15, 18	Sarantos in view of Shie
2B	15, 18, 20, 27	Sarantos and Shie in view of Venkatraman

Already rejected by the ITC

Apple briefed and then withdrew these arguments in the ITC

## Petitioner's Grounds (1465)

Ground	Claims	Basis for Rejection (35 U.S.C. § 103)
1A	2-3, 5-6, 8, 10-12, 14	Iwamiya in view of Sarantos
1B	4, 17, 19, 21-26	Iwamiya in view of Sarantos and Venkatraman
2A	2, 5-6, 8, 10-11, 13-14, 17, 19	Sarantos in view of Shie
2B	3-4, 17, 19, 21-26	Sarantos in view of Shie and Venkatraman
2C	12	Sarantos in view of Shie and Savant

## Claim Construction Disputes

“determine ... oxygen saturation”

Claims 9 and 18

“arranged in an array having a spatial configuration corresponding to a shape of the portion of the tissue measurement site encircled by the light block”

Claims 15, 6, 26

## Claims 9 and 18: “Determine ... Oxygen Saturation” Requires Calculating Oxygen Saturation

### **Both experts agree:**

The claim requires the device to calculate oxygen saturation.

EX2100, ¶¶8-10; EX2101, 69:4-9; Sur-Reply 3

### **Apple’s Shifting Position:**

Response to Expert Testimony: “no construction is necessary”

PRET, 1

Apple’s Reply: satisfied by “rudimentary functions,” and “might not even need to be a measurement”

Reply, 21; EX1042, ¶41; Sur-Reply 3

## Claims 15, 6, 26: “Spatial Configuration ... Corresponding To” Requires Sufficient Detectors To Match Shape

Parent prosecution history addressed limitation “arranged in an array having a spatial configuration corresponding to the shape of the irradiated portion of the tissue measurement site.”

- Requires “a sufficient number of detectors” in an array to “match” the “irradiated portion of the tissue measurement site.”
- Six or more detectors could correspond to a circular shape. Two or three cannot.

Iwamiya + Sarantos  
(Claims 1, 20, and Dependents):  
No Surface Comprising  
A Dark-Colored Coating



## No Dark-Colored Coating

### Iwamiya:

Uses “metal with a light shielding property”

### Duckworth:

Apple “assumed a problem with the light shielding frame that did not exist.”

EX2070, ¶59.

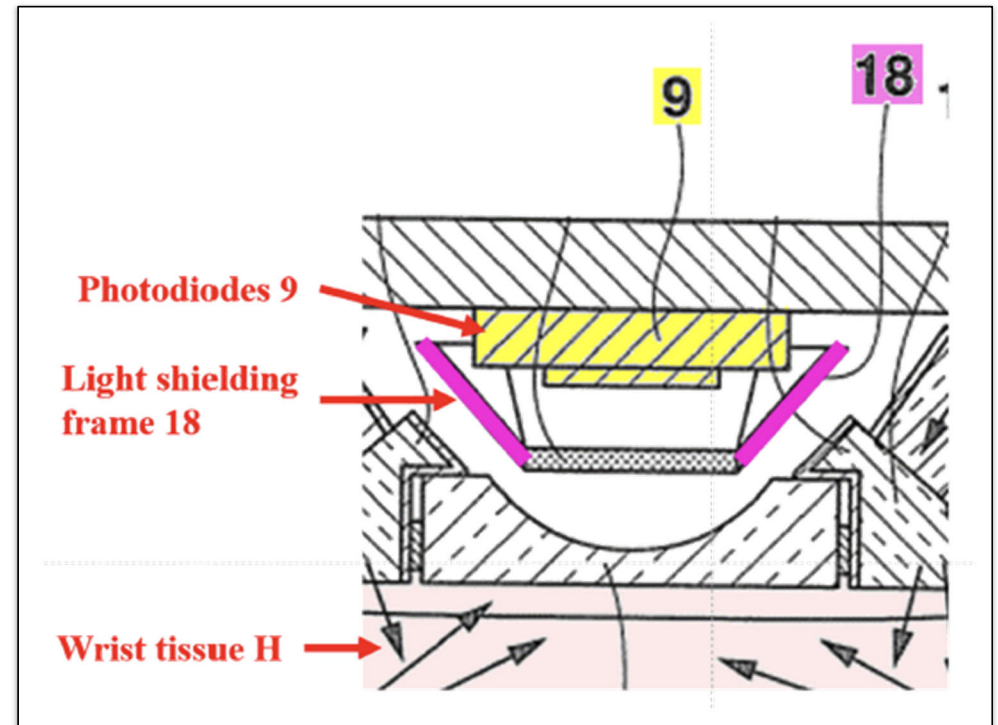

1291 Pet., 15 (Apple’s annotations of EX1004, Fig. 4)

# Dark-Colored Coating Reduces Received Signal

## Experts agree:

Using a dark-colored coating on Iwamiya's light shielding frame would reduce the light signal reflected back to the photodetector.

EX1042, ¶9; EX2100, ¶17.

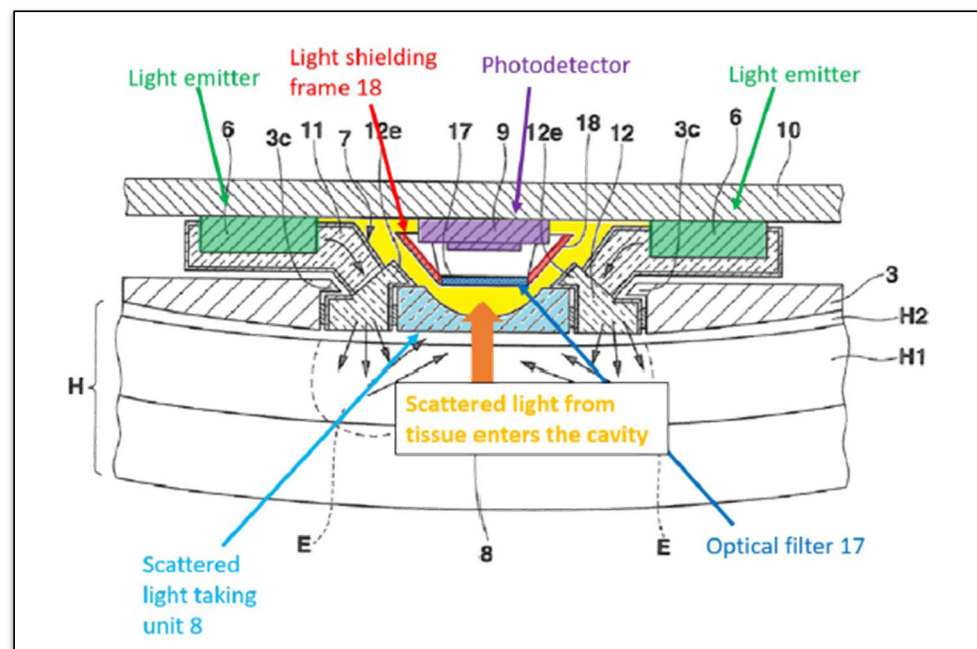

EX2100, ¶17 (annotating EX1004, Fig. 4)

Iwamiya + Sarantos  
(Claims 6, 15, 26, and Dependents):  
No Photodiode “Array” With  
Claimed “Spatial Configuration”

# Petition Did Not Identify Photodiode Arrangement Reply Makes Iwamiya Substantially Worse

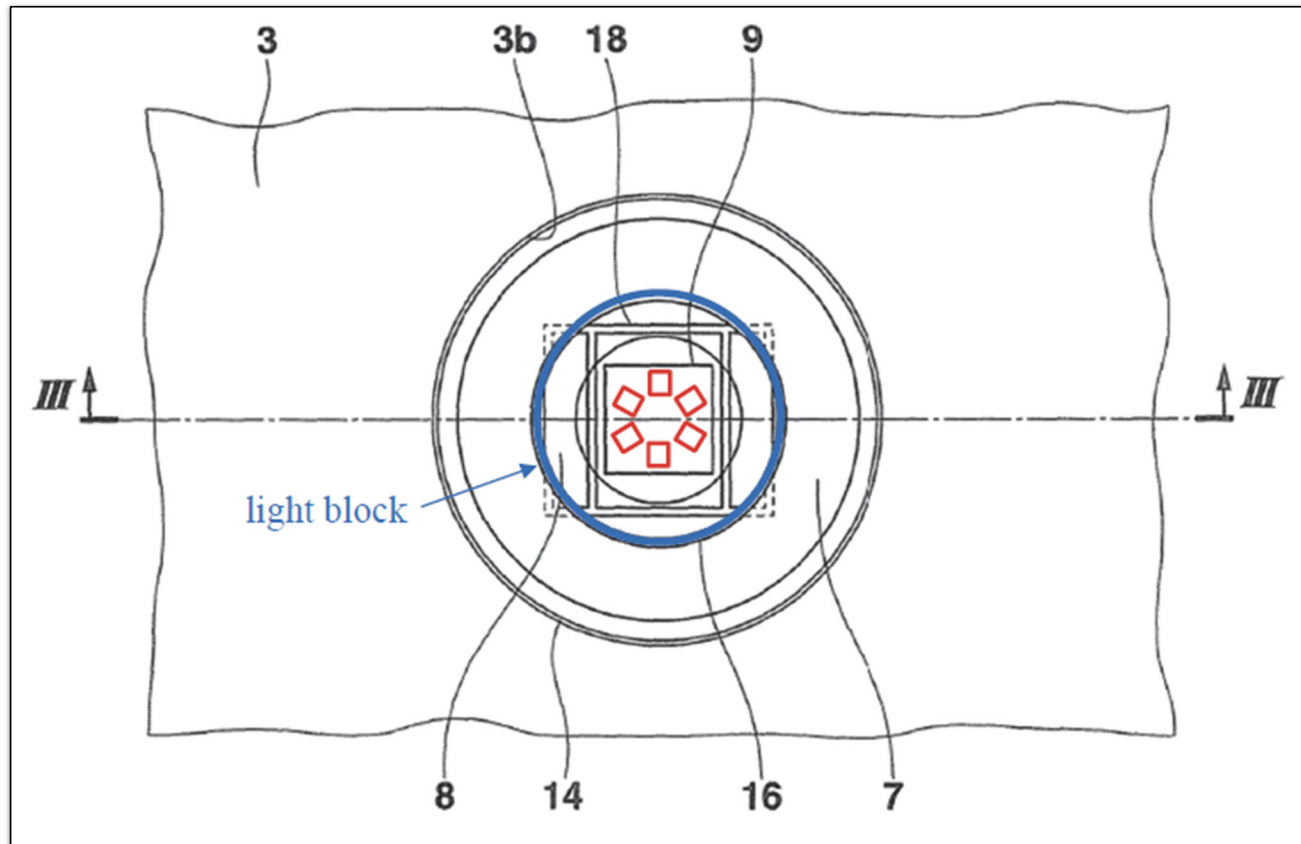

1291 Reply, 9 (Apple's annotations of EX1004, Fig. 2)

# Apple Asserts Modification Increases Detection Area But Actually Does The Opposite

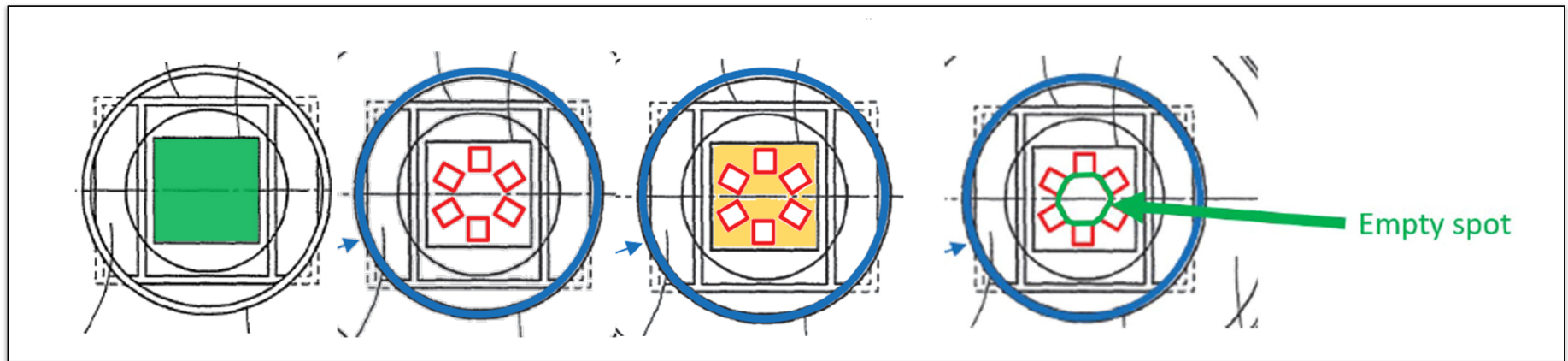

- ⦿ Substantially decreases light sensitivity
- ⦿ Worse signal-to-noise ratio
- ⦿ No light detection at center

# Apple's Alleged Motivation Applies To Opposite Configuration

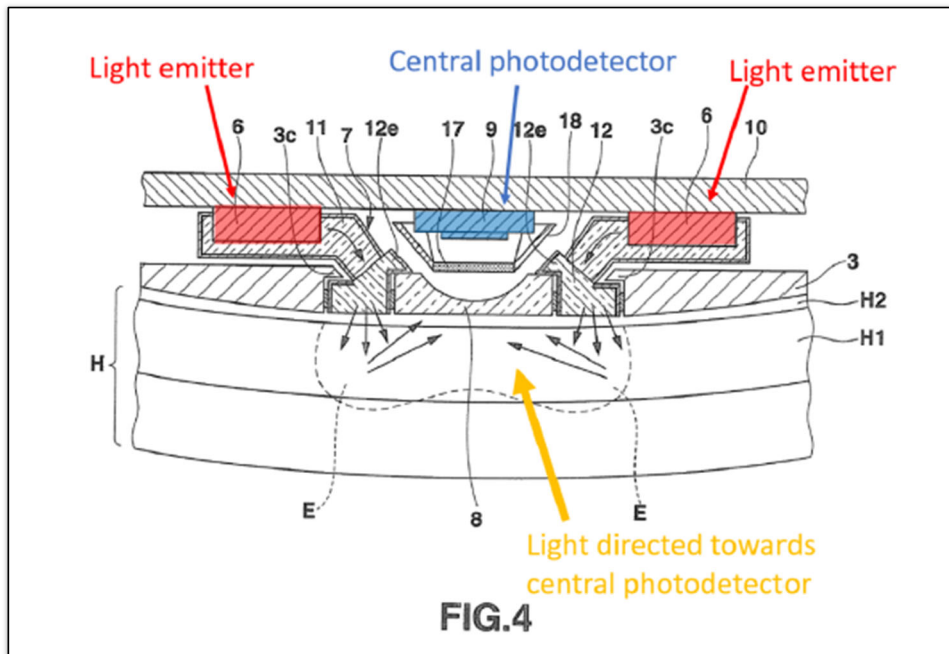

Iwamiya (EX1004):  
Central photodetector, peripheral light emitters

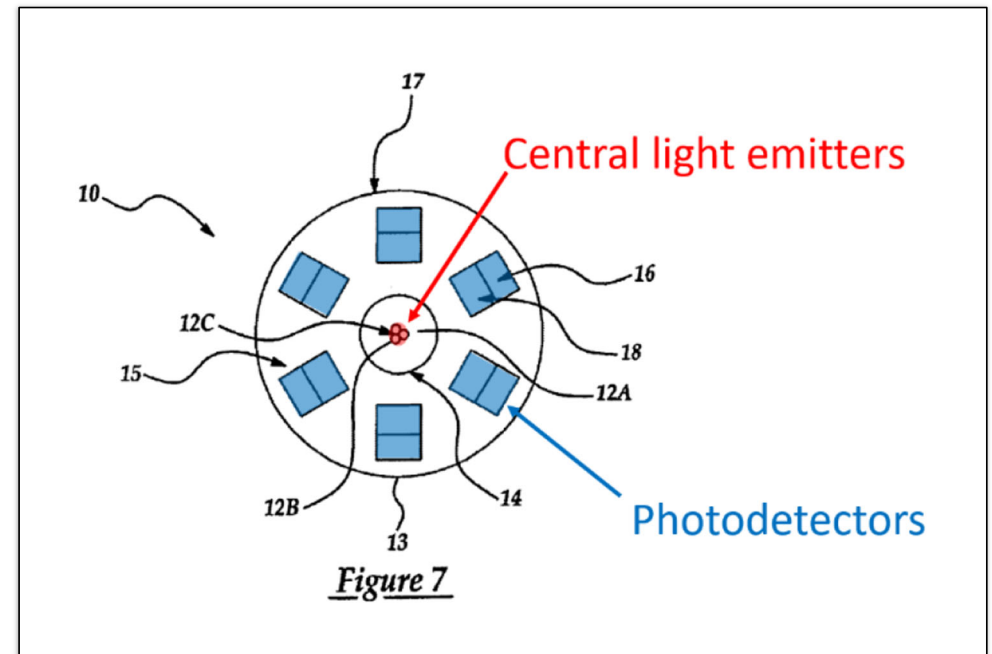

Mendelson (EX1008):  
Central light emitters, peripheral photodetectors

# Iwamiya's "Circumference": Does Not Teach Reduced Signal Strength

**IWAMIYA: DO THIS**

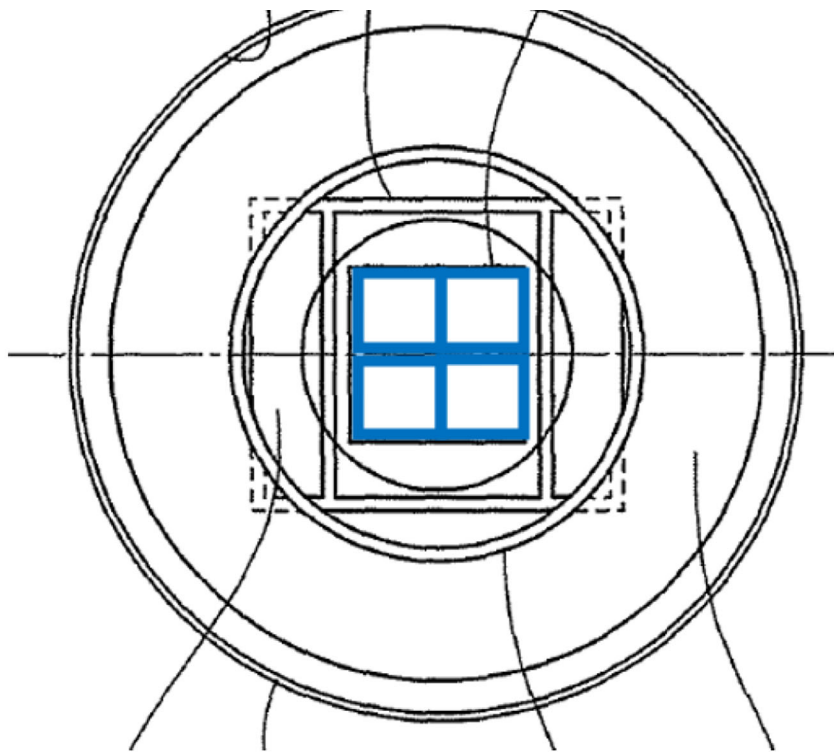

**NOT THIS**

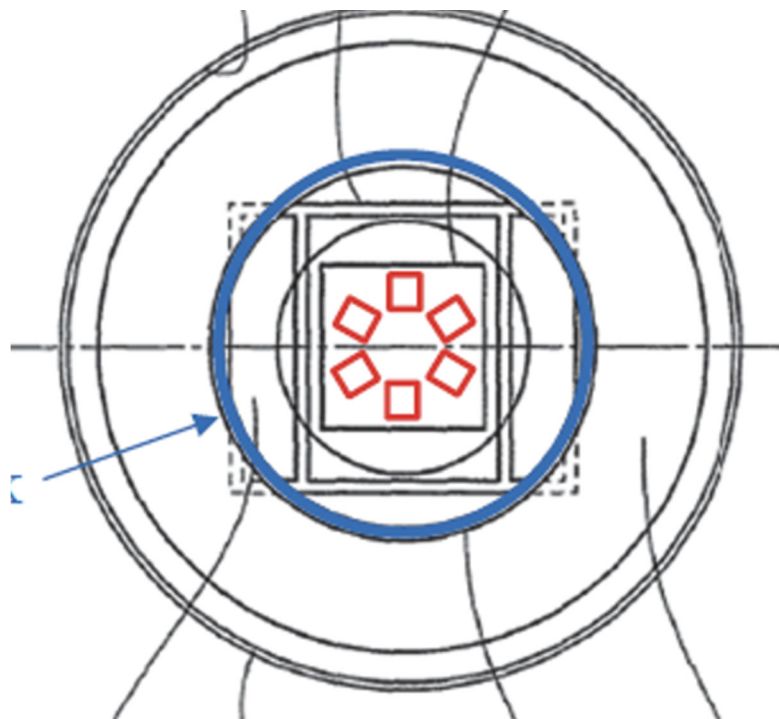

# Iwamiya + Sarantos (Claims 9, 18): No Oxygen Saturation



# Iwamiya Teaches Away From Both Oxygen Saturation And Combination With Sarantos

- ⊙ Iwamiya teaches away from using visible light
- ⊙ Iwamiya + Sarantos inoperable
  - Iwamiya's optical filter blocks light <900 nm
- ⊙ Also applies to claims 2, 27

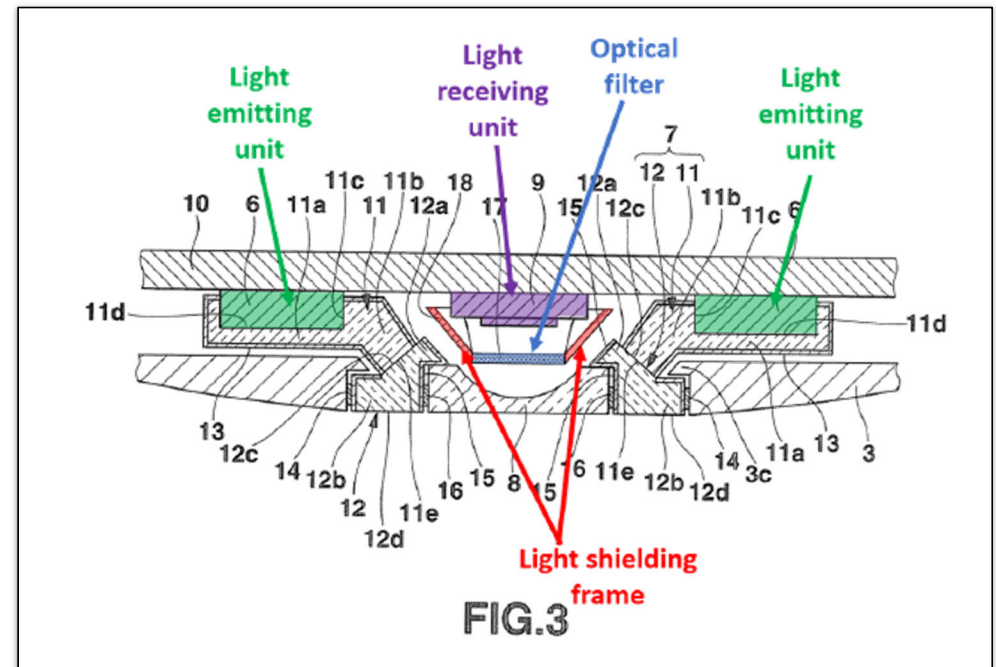

EX1004, Fig. 3; EX2002-1291, ¶94

## Iwamiya Teaches Away From Visible Light Used For Oxygen Saturation

That is, the melanine pigment has extraordinarily high absorbance in a wavelength band from ultraviolet light to visible light. When the large amount of melanine pigment is contained in the epidermis (for example, in the case of a person of a dark skin color), even though observation light having a wavelength of 600 nm or less is irradiated onto the skin, the observation light that reaches the dermis including the blood capillary, repeats scattering and absorption in a dermis tissue, passes through the epidermis again, and arrives at the light receiving unit is weak light and cannot be sufficiently received. Therefore, biological information, such as a pulse wave, cannot be detected.

EX1004, 1:62-2:6

In Iwamiya's sensor design, visible light is "weak" and "biological information ... cannot be detected." EX1004, 10:34-38

# Iwamiya Teaches Away From Using Visible Light

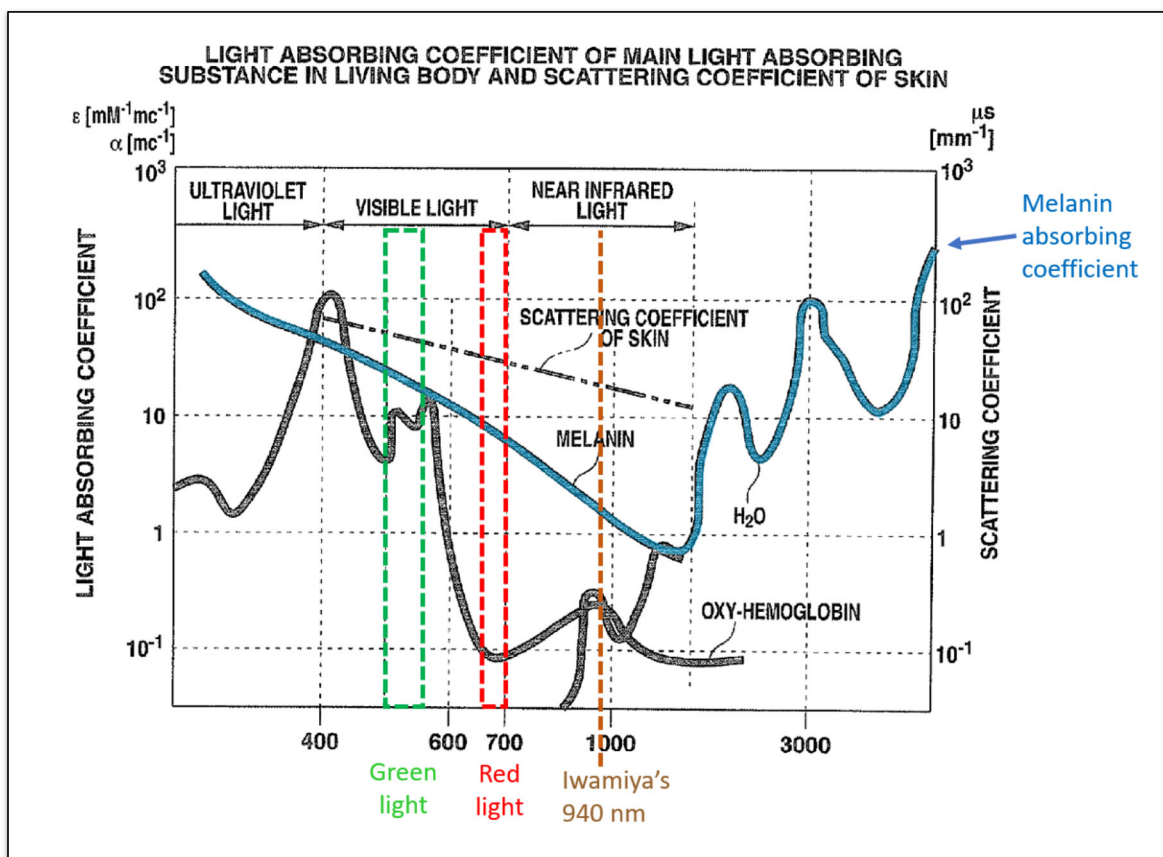

EX2070, ¶47 (annotating EX1004, Fig. 6)

# The Petition's Combination Is Inoperable Because Iwamiya Cannot Measure Light Below 900 nm

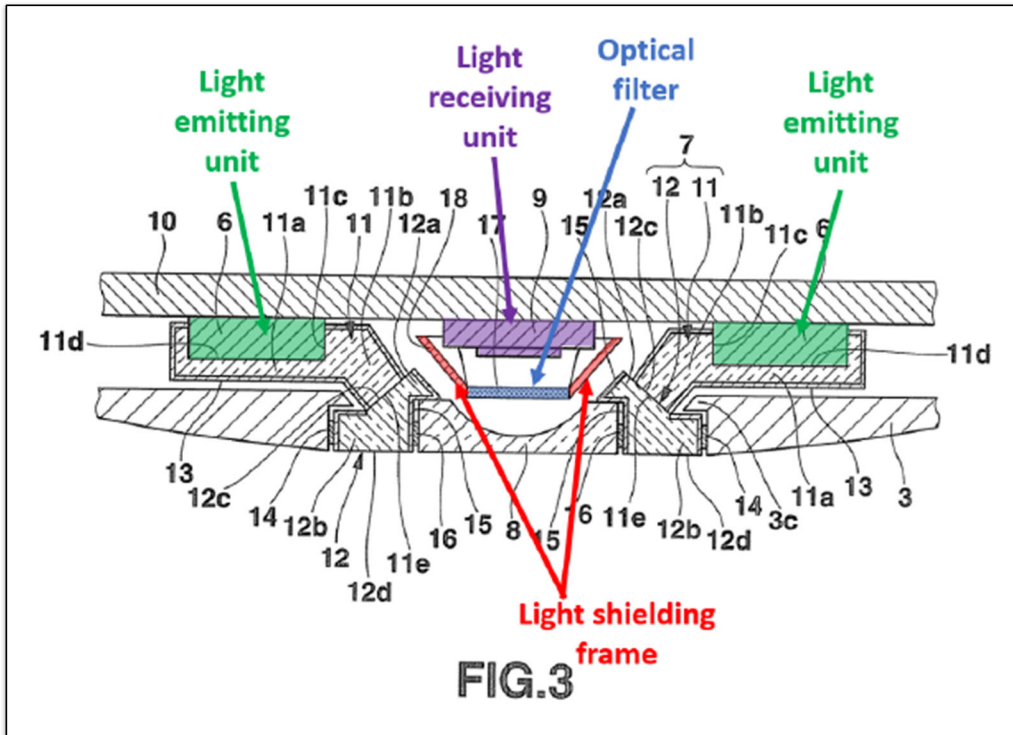

EX1004, Fig. 3; EX2002-1291, ¶194

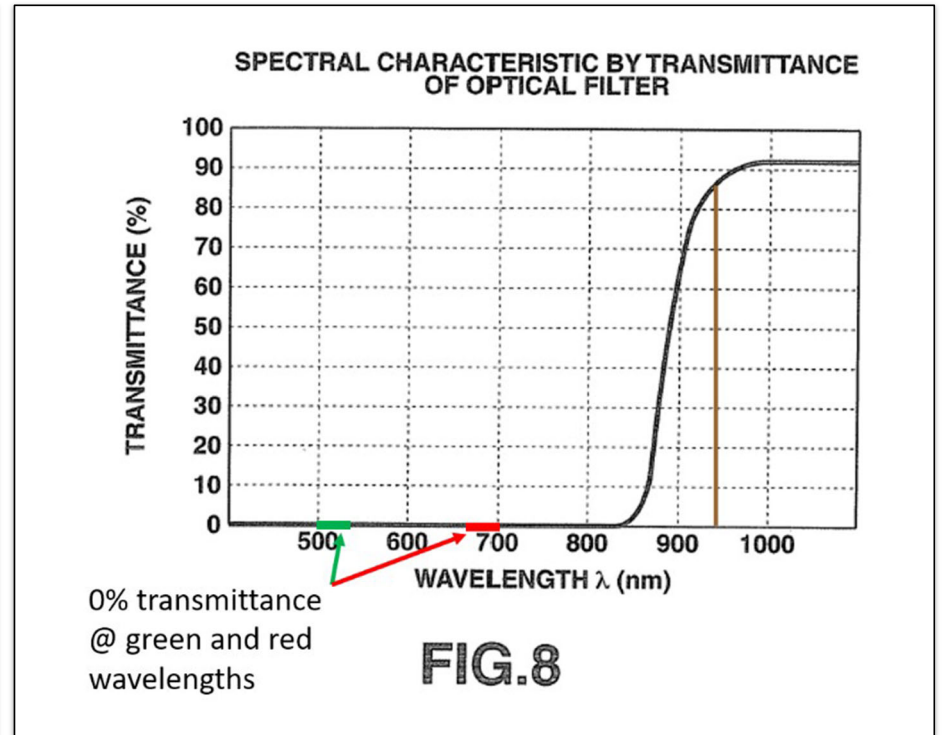

EX1004, Fig. 8; EX2070, ¶49

# Iwamiya's Photodetector Is Insensitive To Red Light

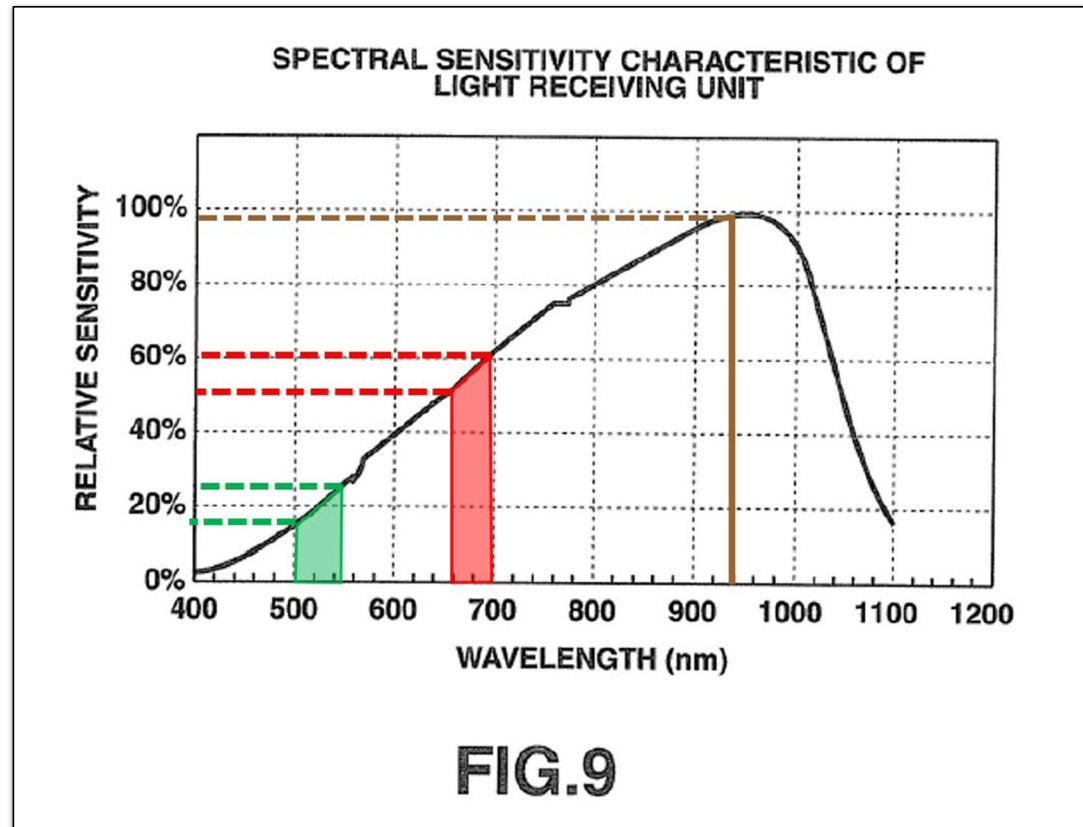

EX1004, Fig. 9

## Sarantos Uses Light From The Visible Spectrum

The above concepts have been discussed primarily with respect to light sources that emit green light, e.g., wavelengths in the range of 500 nm to 550 nm, although it is contemplated that the photodetector element concepts discussed herein may see similar performance with light sources that emit light predominantly in the 500 nm to 600 nm range, which includes yellow light as well as some light orange light. Light sources emitting light in the green spectrum are particularly well-suited for photoplethysmographic techniques for measuring heart rate. In contrast, other photoplethysmo-

EX1005, 18:35-44

## Sarantos: Sensor “Not Tailored” For “Dramatically Different” Red & Infrared Light

for measuring heart rate. In contrast, other photoplethysmographic techniques, such as techniques for measuring blood oxygenation levels, may be most effective using light of dramatically different wavelengths, such as in the red wavelengths, e.g., 660 nm, or in the infrared spectrum. The aspect ratios and dimensional values discussed herein are tailored based on the green/yellow light spectrum and are not tailored for use in other spectrums, such as the red or infrared spectra.

EX1005, 18:44-51

# Fitbit (Sarantos Assignee) Did Not Release A Wrist SpO2 Device Until 2020

Petition: “[W]rist-worn pulse oximetry sensors, **such as that described in Sarantos**, were well-known in the art.” 1291 Pet., 20.

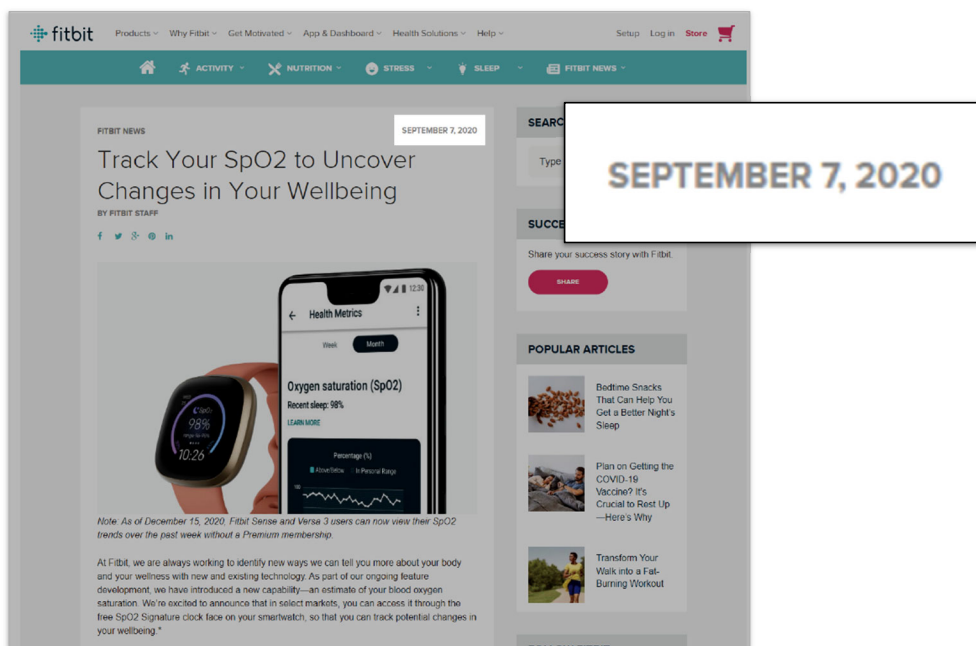

EX2092

## Duckworth:

“[B]ased on my research, it apparently took Fitbit more than five years before it announced (in late 2020) that some of its devices might be able to measure SpO<sub>2</sub>.”

EX2070, ¶154.



## Fitbit In 2020: SpO<sub>2</sub> At Wrist Is A “Hard Technical Problem”

**The Washington Post** *Democracy Dies in Darkness*

### The new Apple Watch says my lungs may be sick. Or perfect. It can't decide.

Both the Apple Watch Series 6 and Fitbit Sense have new blood-oxygen apps. They're mostly useless.

By Geoffrey A. Fowler

Columnist

September 23, 2020

### Fitbit's director of research in 2020:

“It's a pretty hard technical problem to measure SpO<sub>2</sub> on the wrist.”

## Motivation Illusory Because Modification Would Not Expand Iwamiya's Parameters

levels. APPLE-1005, 13:40-14:22; APPLE-1003, [49]. To the extent not disclosed by Iwamiya, a POSITA would have been motivated to determine oxygen saturation using Iwamiya's physiological sensor, based on the teachings of Sarantos, in order to expand the range of physiological parameters measured by Iwamiya's sensor, thereby improving the functionality and utility of the sensor. APPLE-1003, [49]; *see, e.g.*, APPLE-1005, 13:40-14:22. A POSITA would have reasonably expected success in adapting Iwamiya's sensor to this purpose because wrist-worn pulse oximetry sensors, such as that described in Sarantos, were well-known in the art. APPLE-1003, [49]; *see, e.g.*, APPLE-1005, 13:40-14:22, FIG. 2.

## Wrist-Worn Pulse Oximetry Sensors Were Not “Well-Known”

levels. APPLE-1005, 13:40-14:22; APPLE-1003, [49]. To the extent not disclosed by Iwamiya, a POSITA would have been motivated to determine oxygen saturation using Iwamiya’s physiological sensor, based on the teachings of Sarantos, in order to expand the range of physiological parameters measured by Iwamiya’s sensor, thereby improving the functionality and utility of the sensor. APPLE-1003, [49]; *see, e.g.*, APPLE-1005, 13:40-14:22. A POSITA would have reasonably expected success in adapting Iwamiya’s sensor to this purpose because wrist-worn pulse oximetry sensors, such as that described in Sarantos, were well-known in the art. APPLE-1003, [49]; *see, e.g.*, APPLE-1005, 13:40-14:22, FIG. 2.

## Petitioner's Reply Makes New Modifications To Iwamiya

- Modify Iwamiya with one or more red LEDs, which Iwamiya **discourages**. EX2100, ¶34
- Reply changes or removes Iwamiya's optical filter, which Iwamiya requires for improving signal and removing external light. EX2100, ¶¶34-35
- Eliminates the filter and light-shielding frame, which removes the structure in Iwamiya that the Petition modifies with a dark coating. EX2100, ¶35.
- Change Iwamiya's photodiodes to be sensitive to red light, but Iwamiya taught away from visible light. POR, 22-26
- Iwamiya requires IR light to obtain a measurable signal, discourages and filters out visible light, and accordingly teaches away. POR, 22-26

Iwamiya +Sarantos (Claim 25):  
No Second Shape Comprising A Width and  
Different Length

# Iwamiya's Symmetric Shape Does Not Have A Different Width And Length

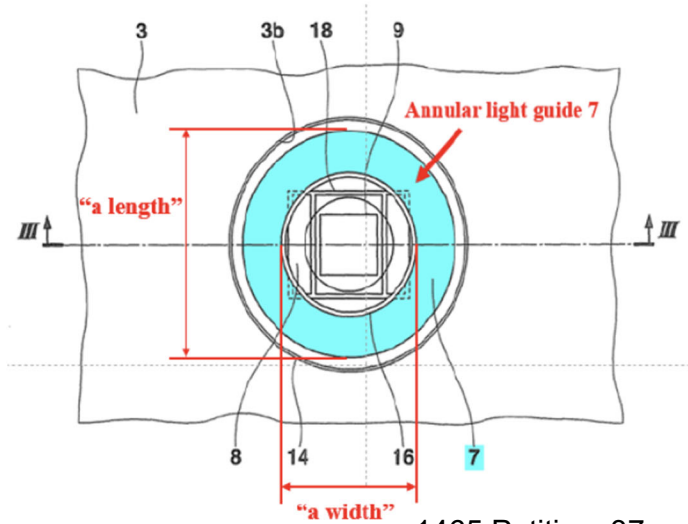

1465 Petition, 37

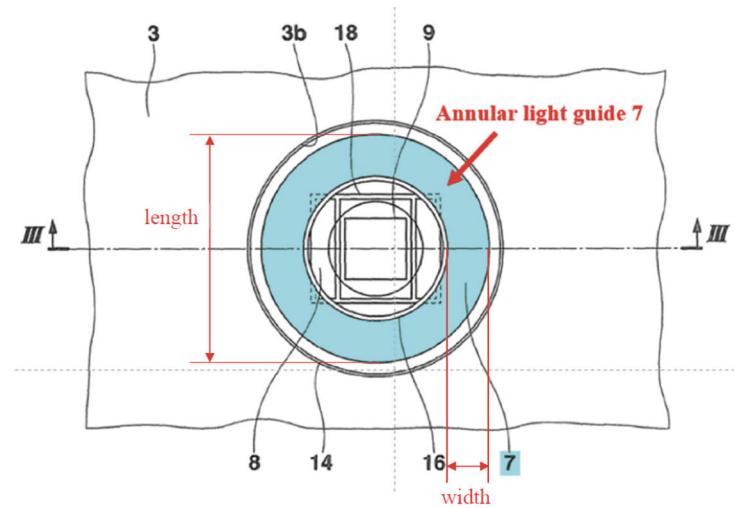

1465 Reply, 22

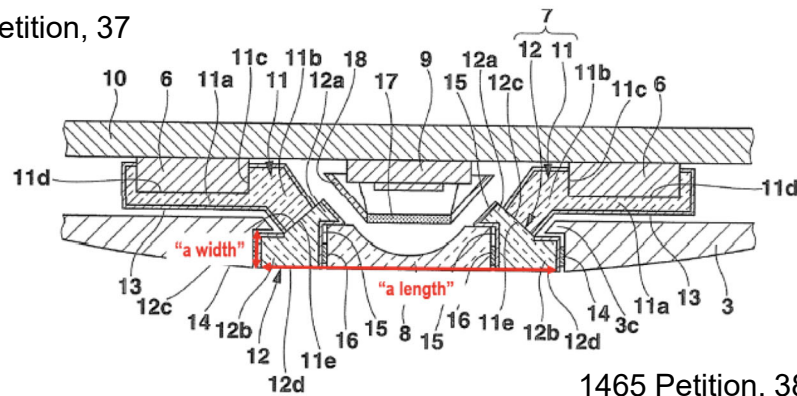

1465 Petition, 38

**Sarantos + Shie**  
**(Claims 1, 19, 20 and Dependents):**  
**No Change From First Shape To Second Shape**

## Petition Provided No Details For Combination

### **Petition:**

“Shie describes a diffuser that has a ‘light diffusing and shaping advantages’ and changes a first shape of light into a second shape.”

1291 Pet., 32

- ⦿ Petition did not identify which “diffuser” to use with Sarantos
- ⦿ Petition did not identify how any diffuser would be implemented



# Sarantos + Shie: What Is The Combination?

## Sarantos + ?

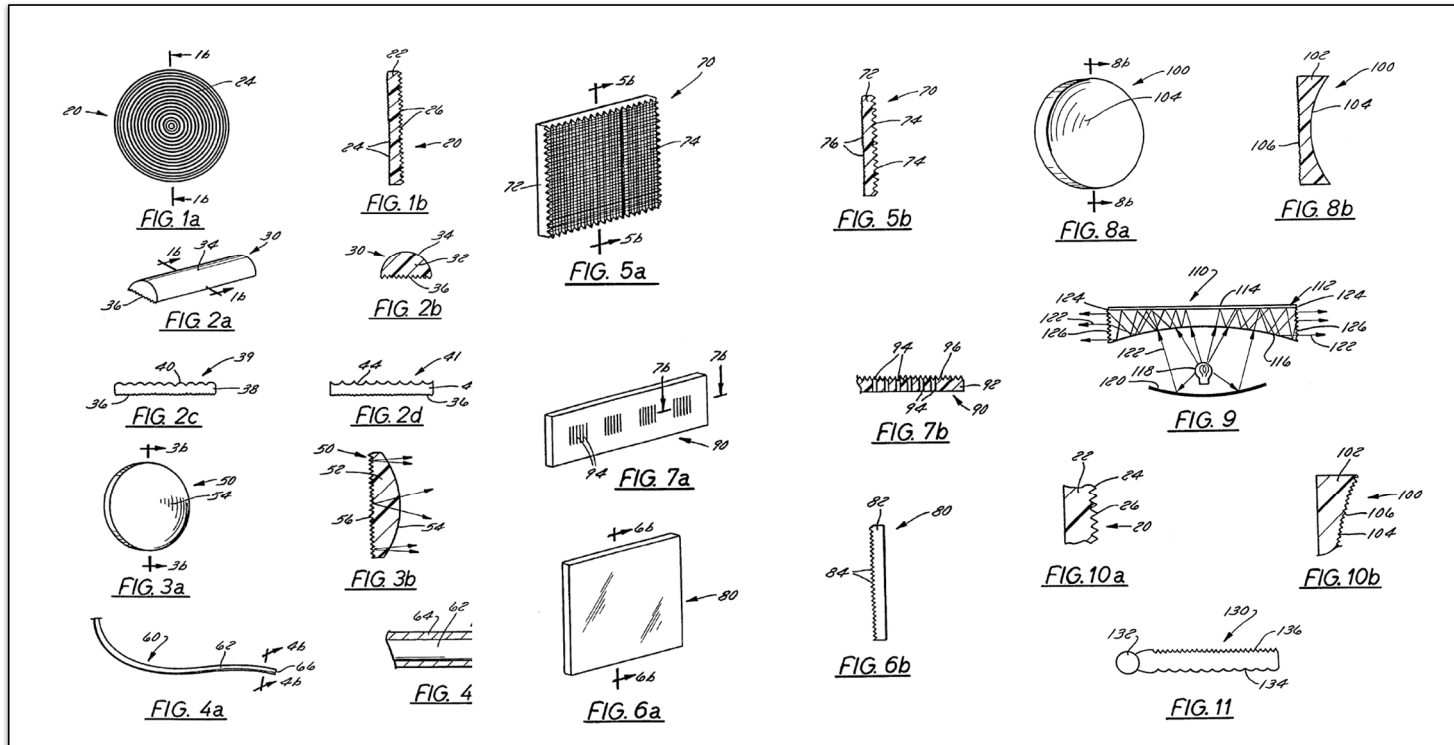

EX1007 (Shie), Figs. 1-11

# “Change The First Shape Into A Second Shape” Change in Size $\neq$ Change in Shape (Claims 1, 20)

At the ITC, Apple agreed that a change in size is not a change in shape

Apple did not give Dr. Anthony Apple’s ITC construction and Dr. Anthony incorrectly understood the first and second shapes could be “the exact same shape.”

EX2071, 76:10-16, 79:8-84:10, 97:17-98:5, 107:18-109:5; 104:3-113:6.

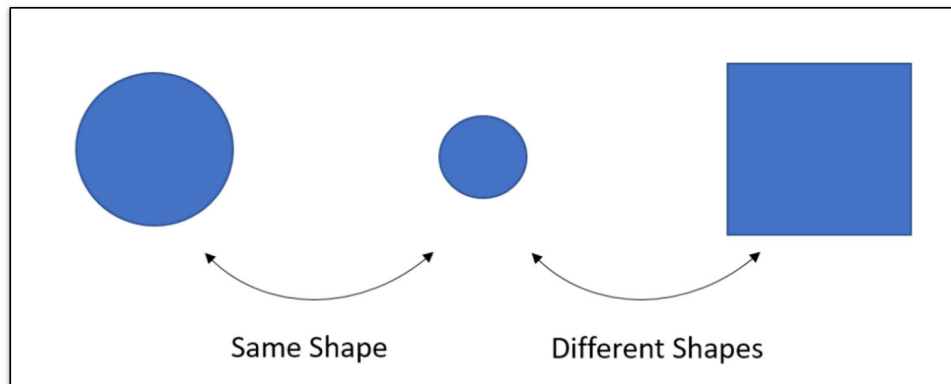

Duckworth Decl. (EX2070) ¶9

# Apple's Reply Changes Theory From Unknown Diffuser To Lenses (But Not Any Of Shie's Optical Elements)

## Petition

Also in the combination, Shie describes a **diffuser** that has a “light diffusing and shaping advantages” and changes a first shape of light into a second shape.

APPLE-1007, 6:61-7:7; APPLE-1003, [76]. It would have been obvious to a POSITA to use the **light shape changing material of Shie** in the wristwatch sensor of Sarantos in between LEDs 2208 and the user's wrist tissue, shown in Fig. 22

above, in order to change the shape of light emitted by the light source into a second shape projected onto the tissue. APPLE-1005, 7:12-16; APPLE-1003, [76]. A POSITA would have been motivated to use a

## Reply

The proposed Sarantos-Shie relies on Shie's general teaching of an optical element that shapes the light output, **not any of Shie's particular optical elements.** Pet., 32. A POSITA would have known that various “optical elements” such as **lenses** “are used routinely to manipulate light in optical instrumentation” and “for **directing the light** from the light source.” APPLE-1046, 10; APPLE-1042, ¶60.

## None Of The Petition's Three Alleged Motivations Have Contemporaneous Evidentiary Support (All Claims)

1. “precisely direct the light emitted toward the tissue”
2. “direct light towards a larger area”
3. “obscure the LED's appearance from a user”

Petition's motivation theory relied solely on Dr. Anthony

# The “Collaborative Writing Effort”: Copy And Paste Apple’s ITC Brief

Anthony relied on documents that he never reviewed and could not identify

the tissue. APPLE-1005, 7:12-16, Fig. 22. A POSITA would have been motivated to use a light shape changing material, such as Shie’s, in order to precisely direct the light emitted toward the tissue so as to increase power efficiency by shining light closer to photodiodes, to increase accuracy of measurements by directing light towards a larger area to decrease irregular readings caused by moles or other aberrations on the skin, and/or to obscure the LED’s appearance from a user. Light shape changing materials were known to be used for such purposes in the prior art, so a POSITA would have reasonably expected Shie’s light shape changing material to work successfully in Sarantos’s sensor. *Id.* ¶¶ 400, 418, 425-28.

Anthony Declaration (EX2002-1291, ¶76)

onto the tissue. RX-0366 [Sarantos] at 7:12-16, Fig. 22; Sarrafzadeh Op. ¶ 403. A POSITA would have been motivated to use a light shape changing material to precisely direct the light emitted toward the tissue so as to increase power efficiency by shining light closer to photodiodes, to increase accuracy of measurements by directing light towards a larger area to decrease irregular readings caused by moles or other aberrations on the skin, and/or to obscure the LED’s appearance from a user. Sarrafzadeh Op. ¶¶ 409-17, 419-24. Light shape changing materials were known to be used for such purposes in the prior art, so a POSITA would have reasonably expected Shie’s light shape changing material to work successfully in Sarantos’s sensor. *Id.* ¶¶ 400, 418, 425-28.

Apple’s ITC  
Pre-Hearing Brief  
(EX2052, 175)

# Apple's Alleged Motivation To Direct Light Towards The Tissue Does Not Make Sense For Sarantos

Sarantos' LED light is already directed toward the tissue

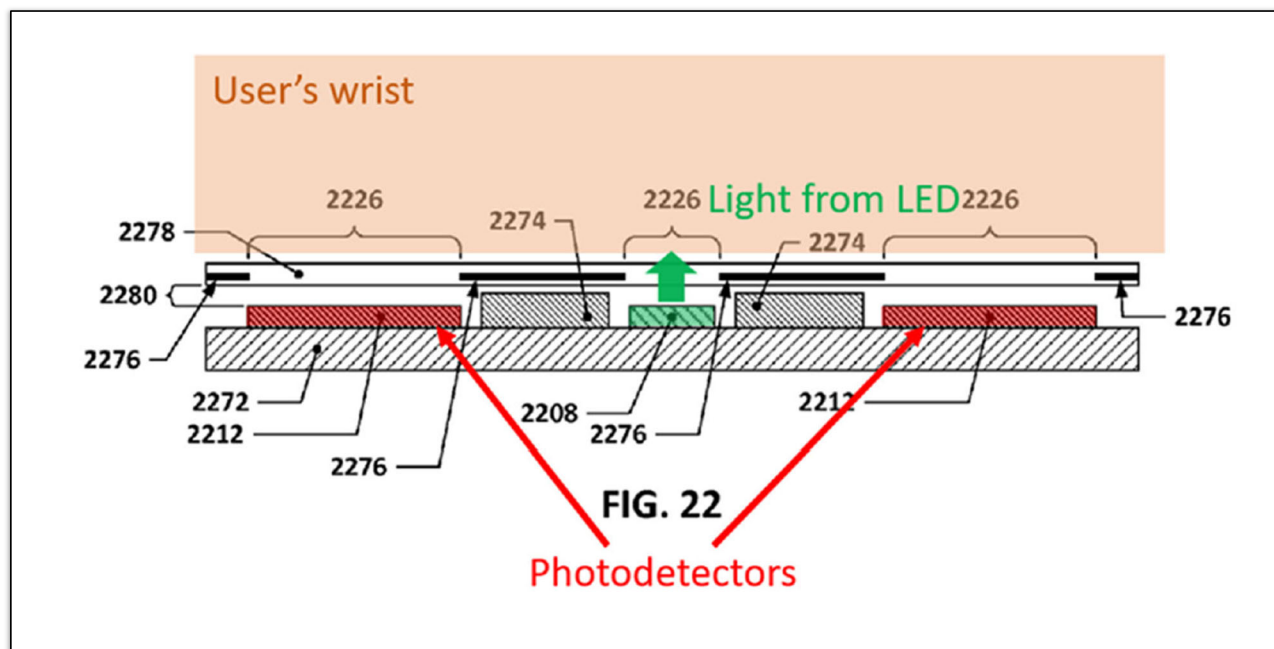

# No Need To Redirect Light In Sarantos Because HAR Detectors Already Capture Nearly All Light

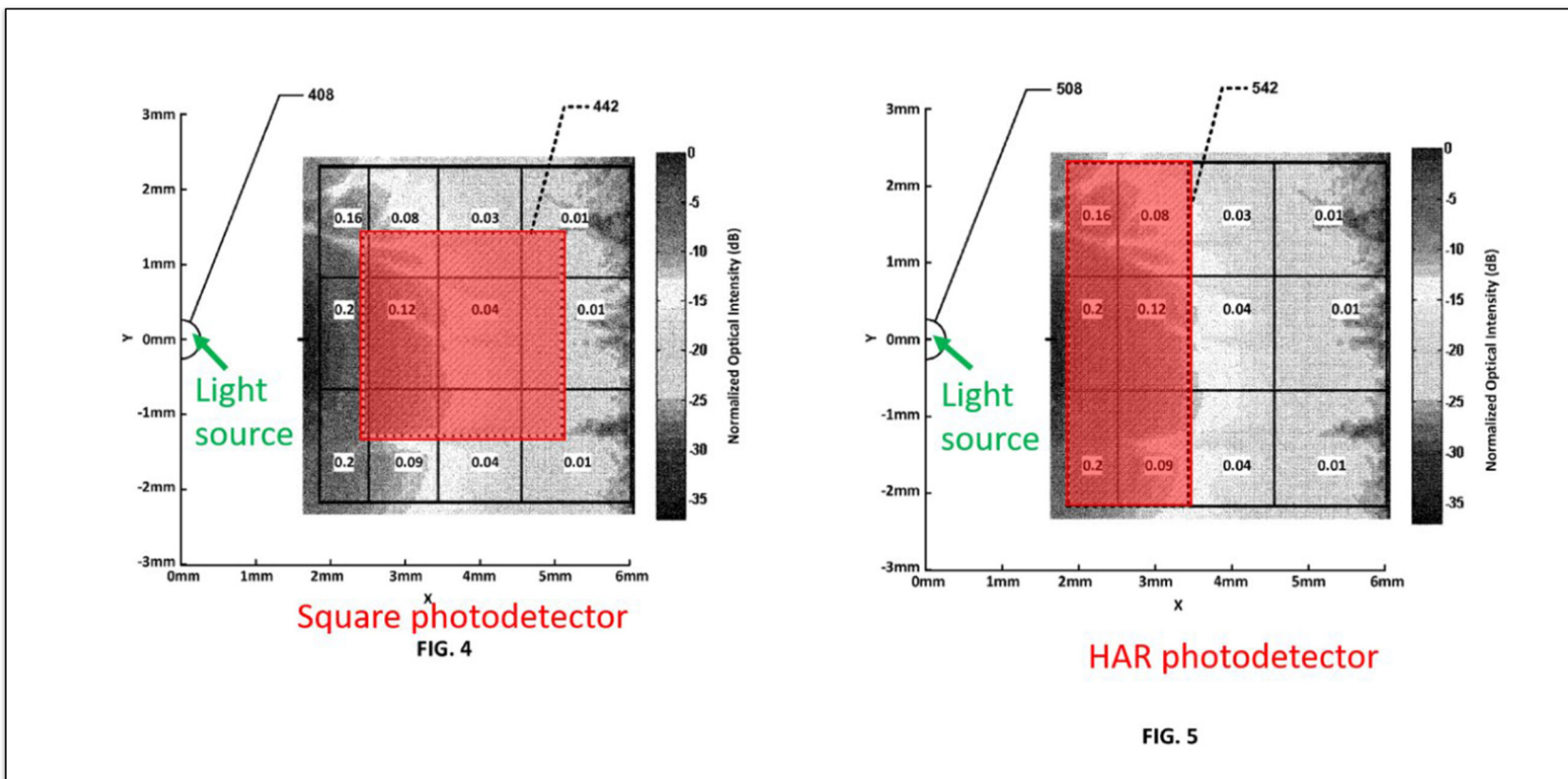

# Sarantos Discourages Apple's "Spreading" Motivation

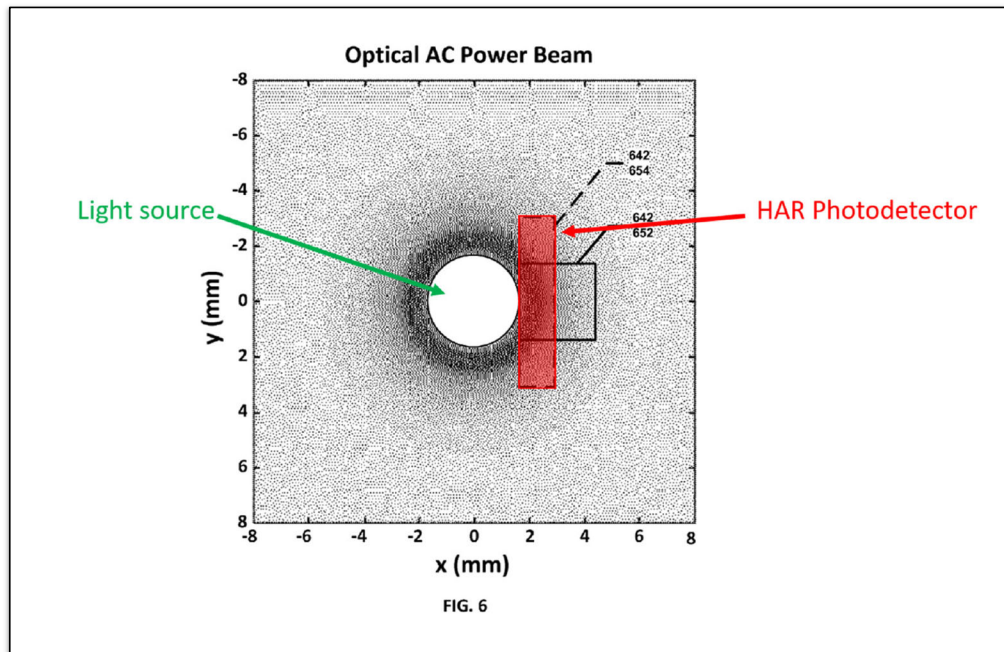

- ⊙ Spreading contrary to Sarantos's teaching
- ⊙ Apple's "spreading" motivation opposite to "directing" motivation
- ⊙ No cited art supports theory that "spreading" helps (e.g., "mole" problem)



## Apple Imagines Shape Of Light After It Passes Through Tissue

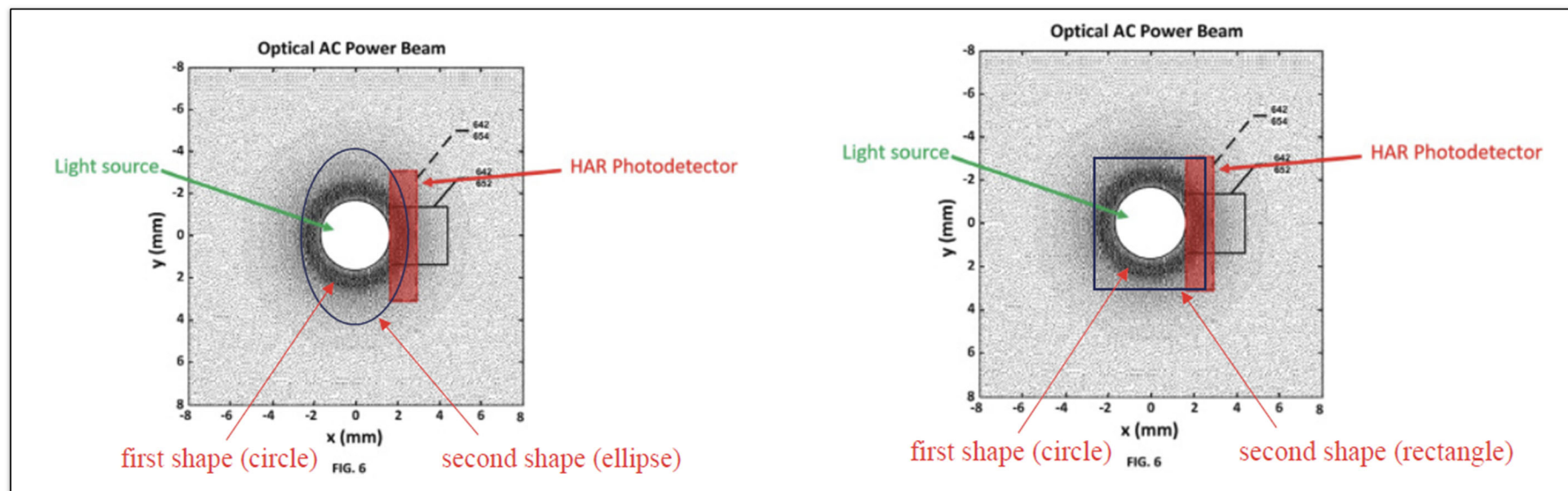

EX1042 (Anthony), ¶164

- ⊙ Apple's annotated figures show the light **after** it passes through **tissue**; provides little insight to change in shape caused by material
- ⊙ No evidence reflected light would provide "ellipse" or "rectangle"

## Dr. Anthony's Reply Declaration Applies A Theory That Conflicts With Apple's ITC Position

There is no change in shape according to Apple's ITC arguments and expert

**Dr. Anthony's Reply Declaration** assumed, *e.g.*, that light from a square LED is square, with

“no change in shape between the LEDs and the diffuser.”

EX1042, ¶¶53, 58.

But before the ITC, **Apple argued:**

- Relevant comparison is between light when it reaches material and emerges from material

EX2074 at 65:18-23

- Light from LED “changes from a square to a circular shape without passing through any material....”

EX2050, 160, 166-168.

## Apple Tried and Failed to Implement the Alleged “Obvious” Modification

Apple’s Reply: modify Sarantos’s pulse sensor with an LED and “Fresnel-type lens[.]” 1291 Reply, 24-25

- ⦿ Dr. Mannheimer determined that Apple could not measure oxygen saturation by adding LEDs to a “Series 0” pulse sensor with a Fresnel lens
- ⦿ Dr. Mannheimer concluded: “Invention is required” for optical properties
- ⦿ Apple replaced Fresnel lens with microlens array in Series 6
- ⦿ No motivation to obscure LED when result non-functional
- ⦿ LEDs not visible regardless

Sarantos + Shie  
(Claim 15 and Dependents):  
No Light Block Having a Circular Shape And  
No Claimed “Array” of Photodiodes

## Sarantos' Figures 22 and 25 Are Not Cohesive

- Reply combines embodiments for the first time.
- Proposed combination includes features not found in Sarantos or Shie

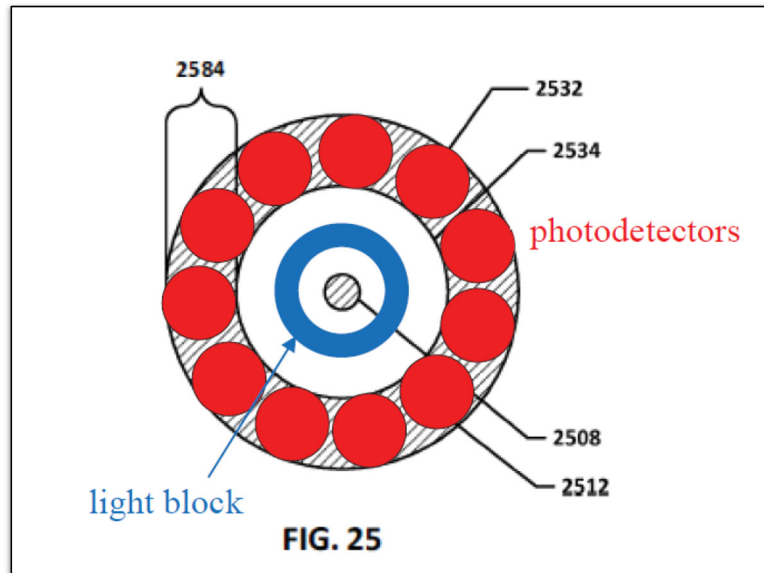

Reply, 28

(Apple's added annotations to EX1005, Fig. 25)

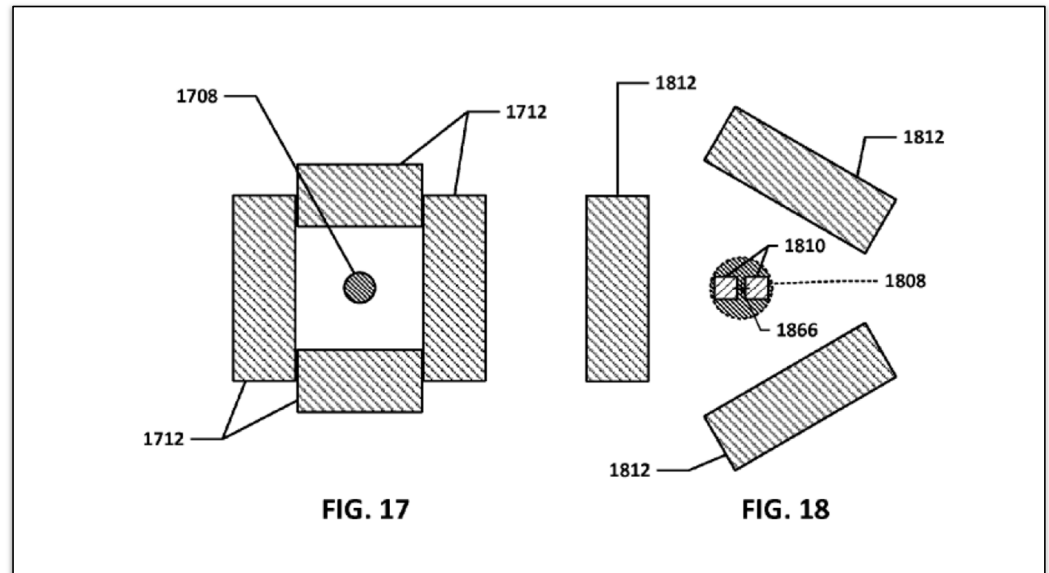

EX1005, Figs. 17, 18

Claims 9, 18 (All Grounds):  
Determining Oxygen Saturation At The Wrist  
Was Not Obvious in 2015  
(Public Session Evidence)

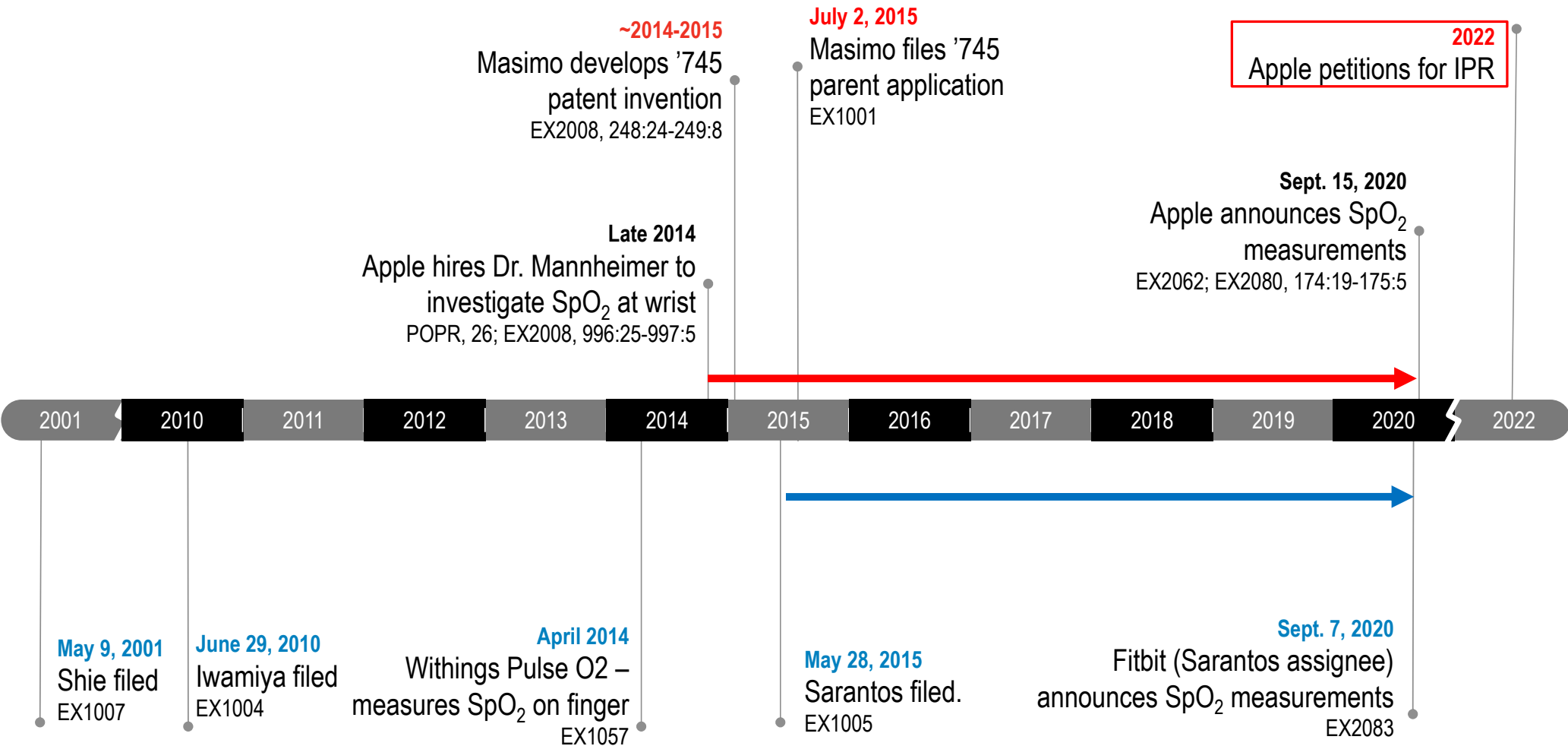

## Iwamiya Teaches Away From Oxygen Saturation Measurements

- **Never** mentions oxygen saturation
- Measures **only** one wavelength in non-visible spectrum (940 nm infrared)
  - EX1004, 10:34-38, 11:19-23, EX2002-1291, ¶80
- ⊙ **Filters out** visible light, including red light used for oxygen saturation
  - EX1004, 8:37-47, Figs. 3-4, 8; EX2002-1291, ¶83, EX2070, ¶49
- ⊙ **Experts agree**: no known method to measure oxygen saturation with one wavelength.
  - EX2002-1291, ¶80; EX2071, 41:10-17



## Sarantos: Sensor “Not Tailored” For “Dramatically Different” Red & Infrared Light

for measuring heart rate. In contrast, other photoplethysmographic techniques, such as techniques for measuring blood oxygenation levels, may be most effective using light of dramatically different wavelengths, such as in the red wavelengths, e.g., 660 nm, or in the infrared spectrum. The aspect ratios and dimensional values discussed herein are tailored based on the green/yellow light spectrum and are not tailored for use in other spectrums, such as the red or infrared spectra.

EX1005, 18:44-51

# Fitbit (Sarantos Assignee) Did Not Release A Wrist SpO2 Device Until 2020

Petition: “[W]rist-worn pulse oximetry sensors, **such as that described in Sarantos**, were well-known in the art.” 1291 Pet., 20.

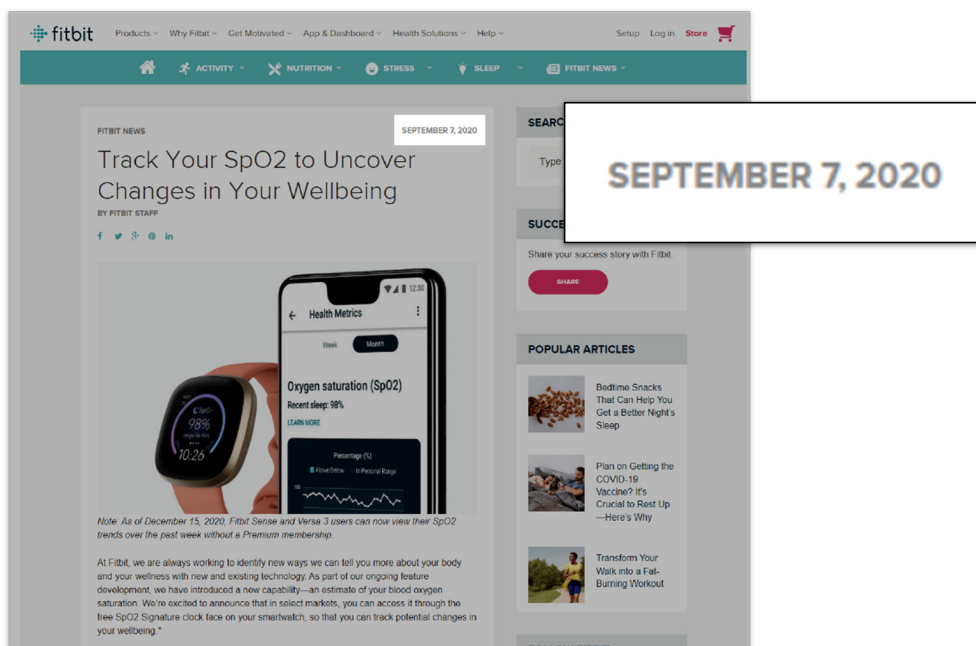

EX2092

## Duckworth:

“[B]ased on my research, it apparently took Fitbit more than five years before it announced (in late 2020) that some of its devices might be able to measure SpO<sub>2</sub>.”

EX2070, ¶154.

# Fitbit In 2020: SpO<sub>2</sub> At Wrist Is A “Hard Technical Problem”

**The Washington Post** *Democracy Dies in Darkness*

## The new Apple Watch says my lungs may be sick. Or perfect. It can't decide.

Both the Apple Watch Series 6 and Fitbit Sense have new blood-oxygen apps. They're mostly useless.

By Geoffrey A. Fowler

Columnist

September 23, 2020

### Fitbit's director of research in 2020:

“It's a pretty hard technical problem to measure SpO<sub>2</sub> on the wrist.”

## Withings Pulse O2 (April 2014): “Seriously Annoying”

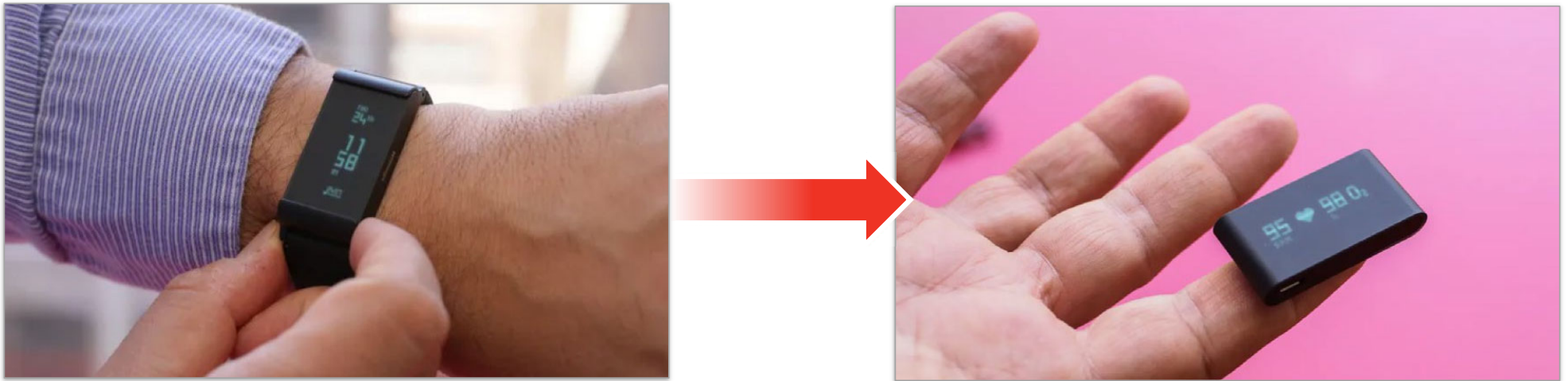

- ⦿ Must remove from wrist because it “requires your finger to use”
- ⦿ “Seriously annoying” design shows determining oxygen saturation at the wrist was not well-known and was still an unsolved challenge. EX2100, ¶80.

# Objective Evidence Confirms Nonobviousness

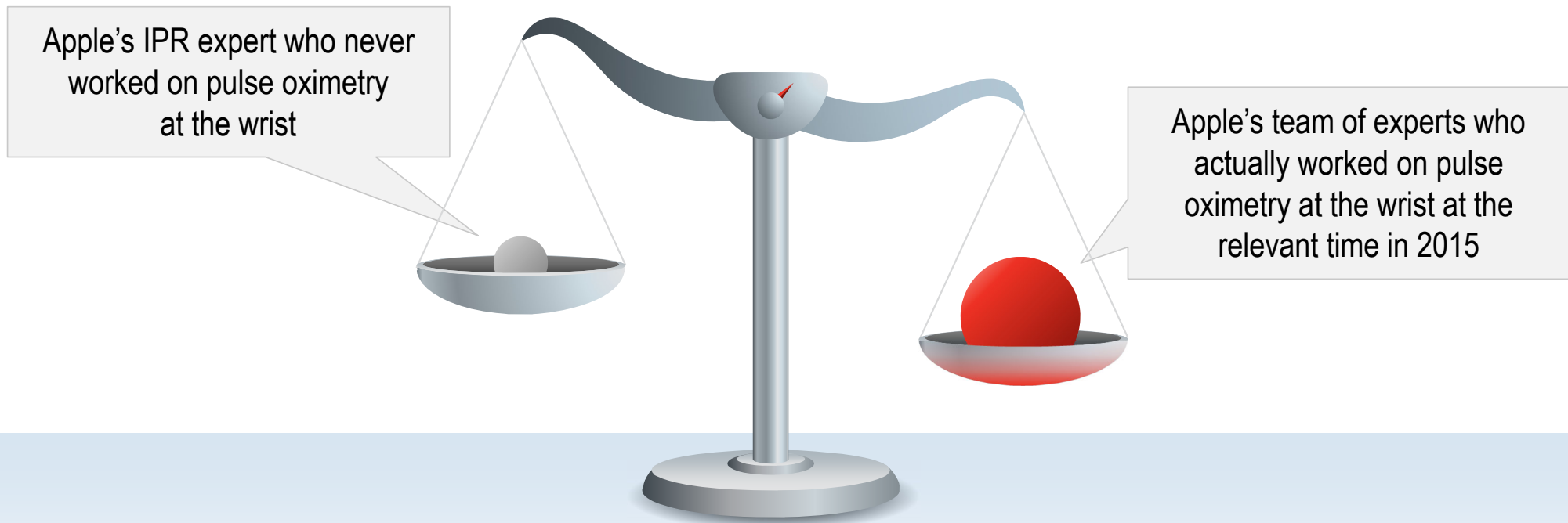

**CONFIDENTIAL SESSION**

DEMONSTRATIVE EXHIBIT – NOT EVIDENCE

62









































































