



(19) **United States**

(12) **Patent Application Publication** (10) **Pub. No.: US 2004/0117330 A1**
Ehlers et al. (43) **Pub. Date: Jun. 17, 2004**

(54) **SYSTEM AND METHOD FOR CONTROLLING USAGE OF A COMMODITY**

(60) Provisional application No. 60/368,963, filed on Mar. 28, 2002. Provisional application No. 60/383,027, filed on May 24, 2002.

(76) Inventors: **Gregory A. Ehlers**, Bradenton, FL (US); **James H. Turner**, Chesterfield, VA (US); **Joseph Beaudet**, Prince George, VA (US); **Ronald Strich**, Pueblo West, CO (US); **George Loughmiller**, Scottsdale, AZ (US)

Publication Classification

(51) **Int. Cl.⁷** **G06F 17/00**
(52) **U.S. Cl.** **705/412**

Correspondence Address:
HOWARD & HOWARD ATTORNEYS, P.C.
THE PINEHURST OFFICE CENTER, SUITE #101
39400 WOODWARD AVENUE
BLOOMFIELD HILLS, MI 48304-5151 (US)

(57) **ABSTRACT**

A system and method manage delivery of energy from a distribution network to one or more sites. Each site has at least one device coupled to the distribution network. The at least one device controllably consumes energy. The system includes a node and a control system. The node is coupled to the at least one device for sensing and controlling energy delivered to the device. A control system is coupled to the node and distribution network for delivering to the node at least one characteristic of the distribution network. The node for controls the supply of energy to the device as a function of the at least one characteristic.

(21) Appl. No.: **10/628,644**

(22) Filed: **Jul. 28, 2003**

Related U.S. Application Data

(63) Continuation of application No. 10/402,370, filed on Mar. 28, 2003, now abandoned.

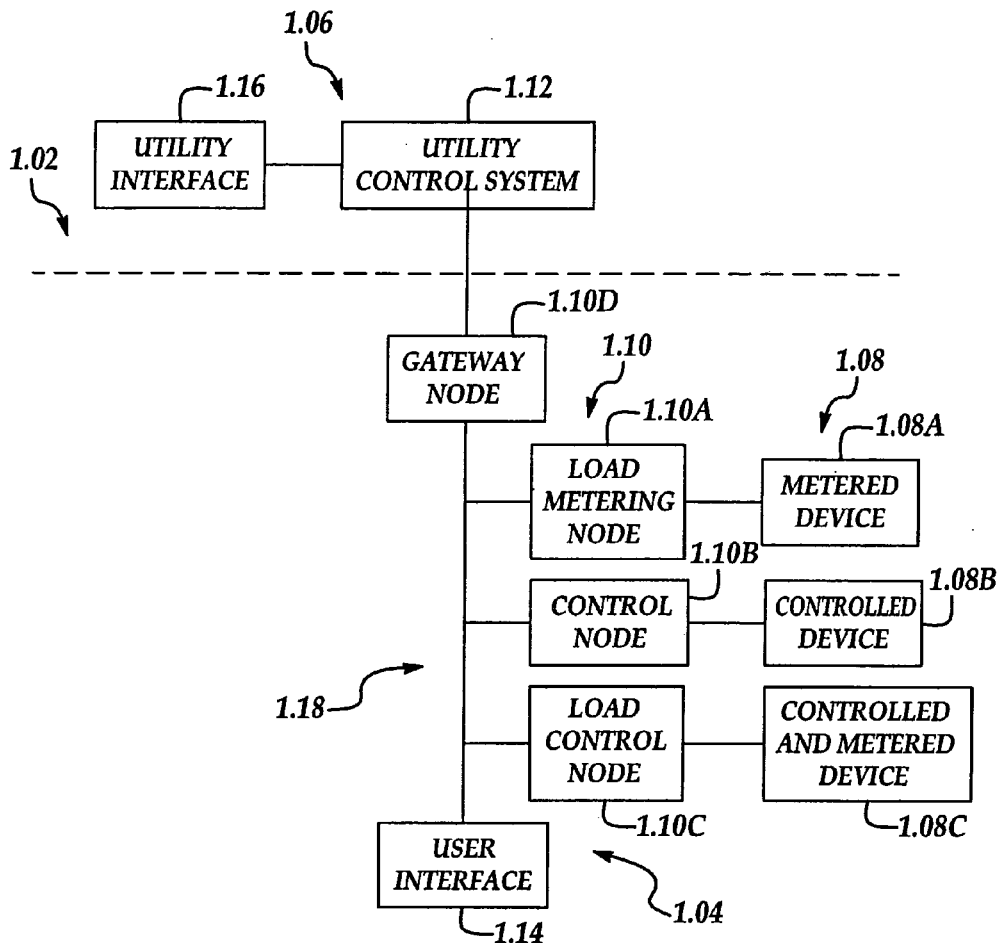

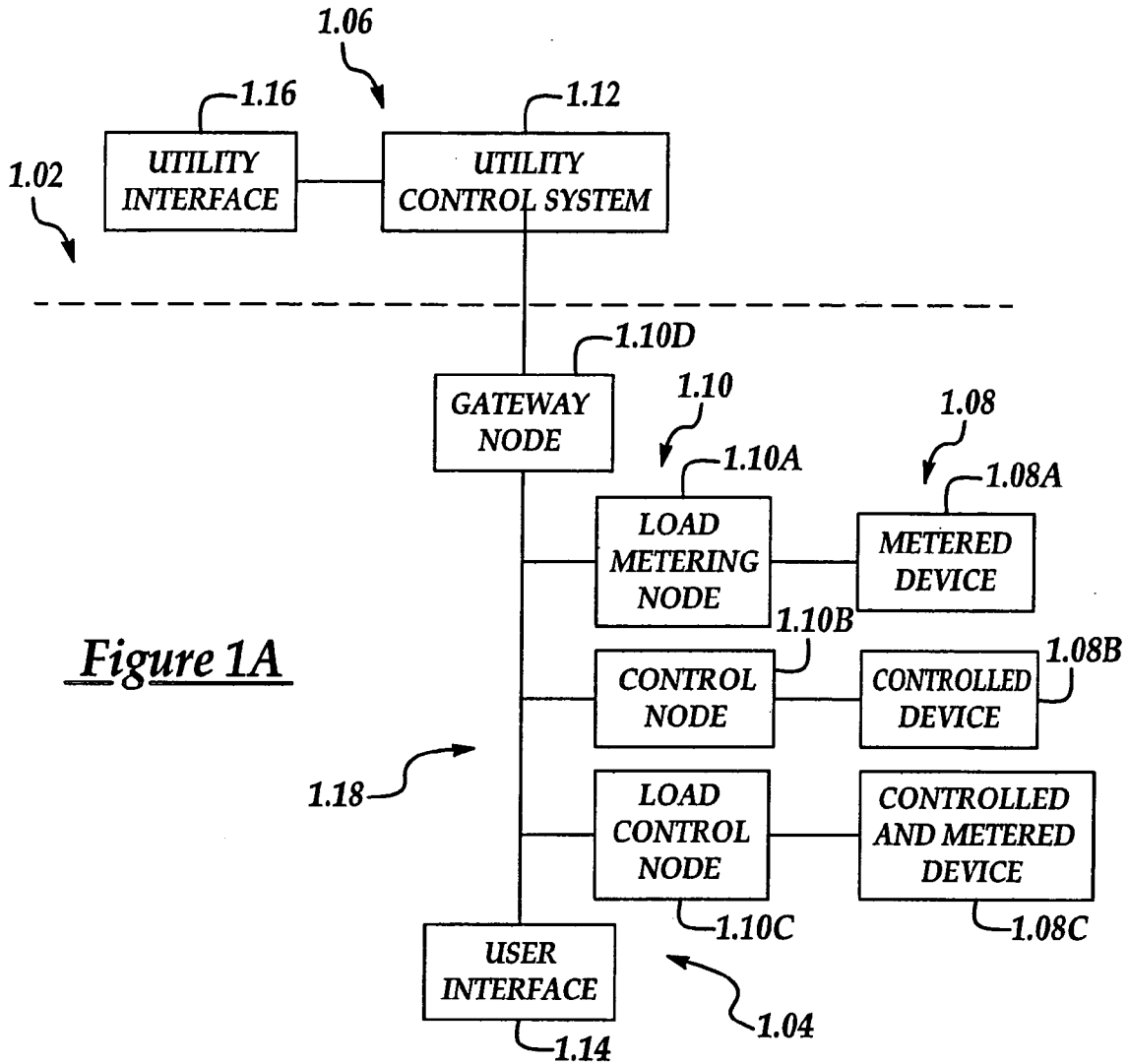

Figure 1A

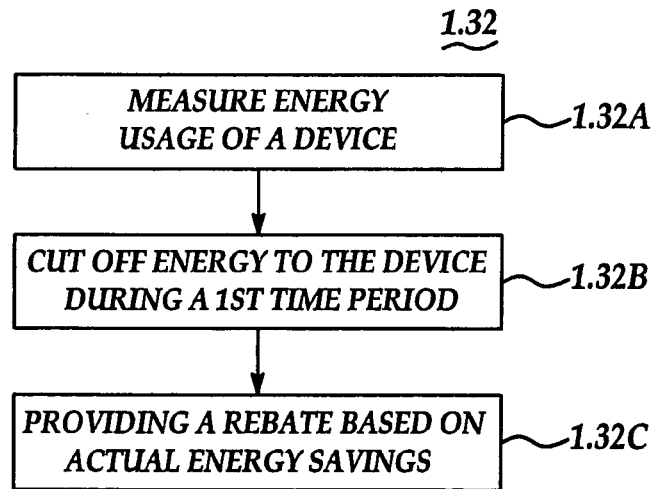

Figure 1C

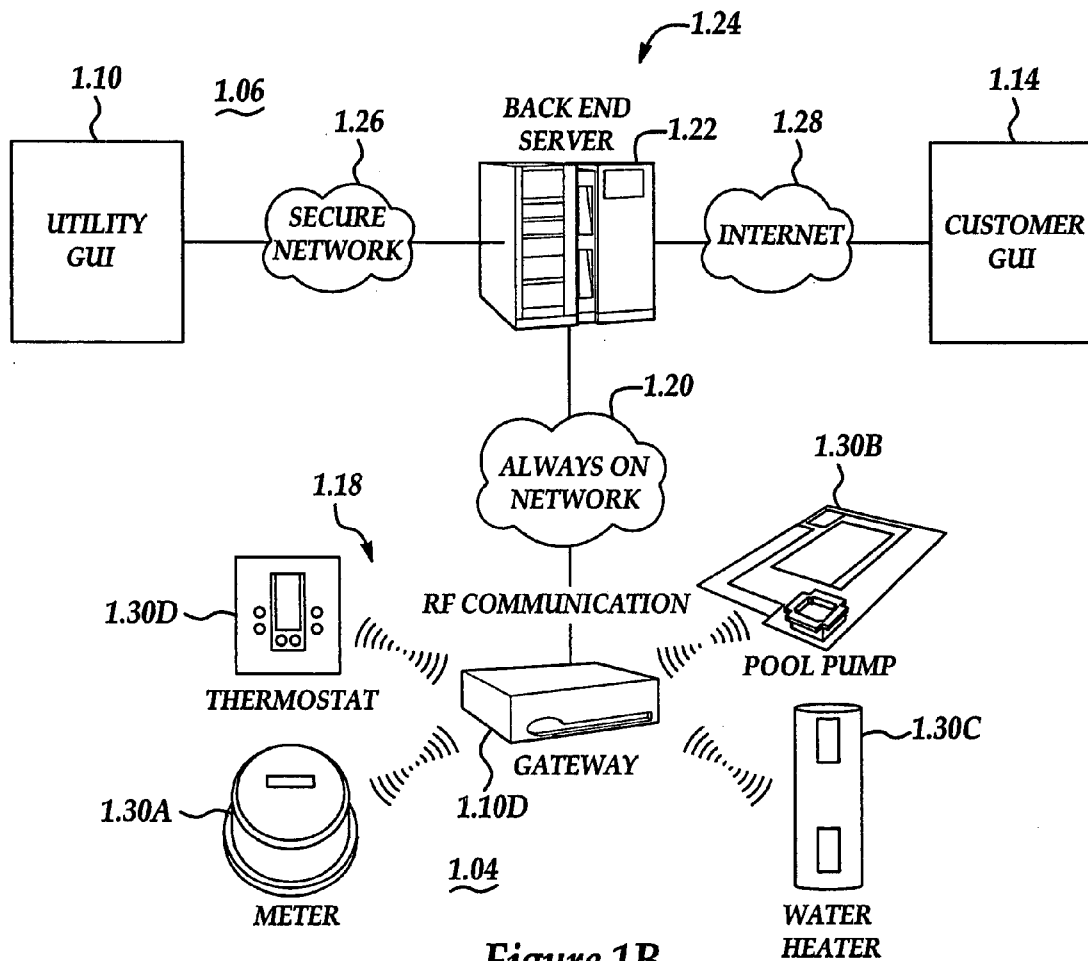

Figure 1B

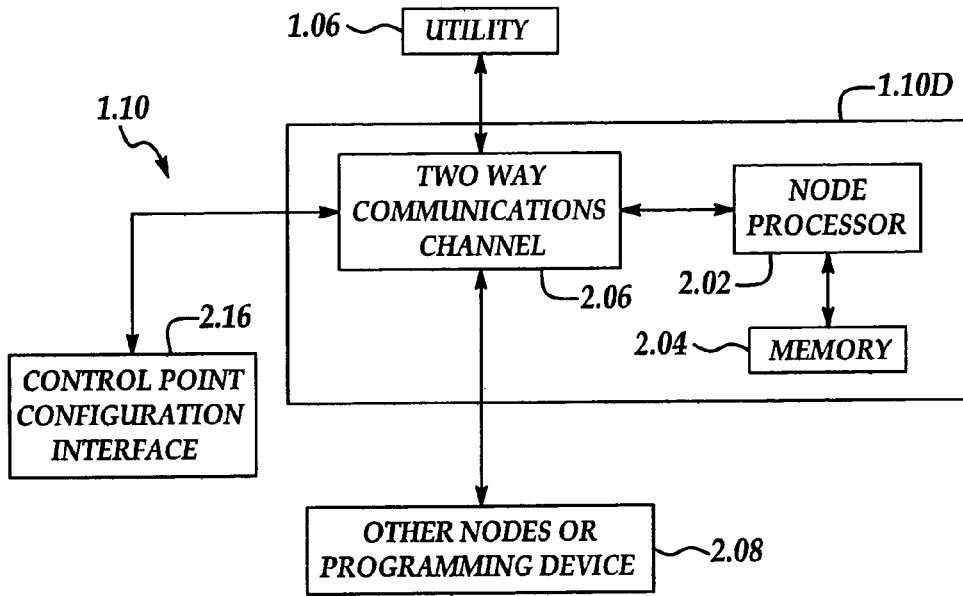

Figure 2A

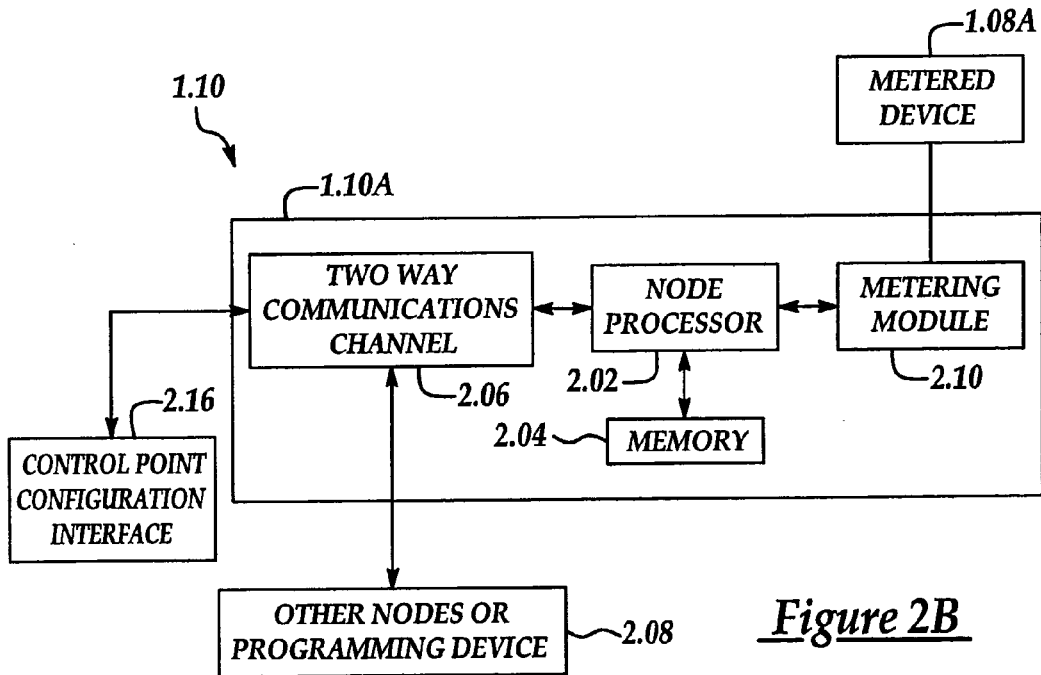

Figure 2B

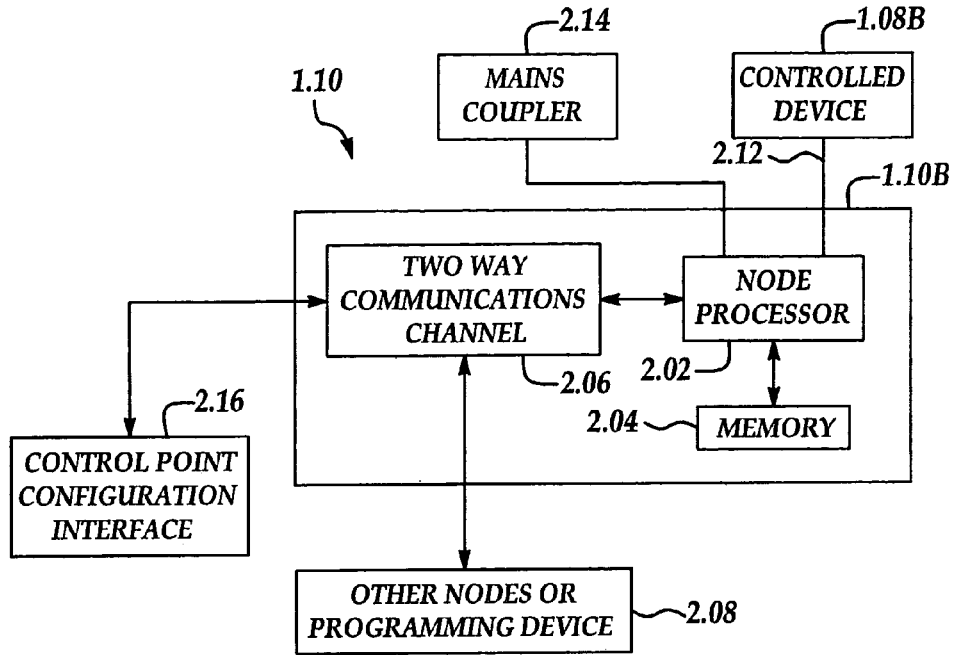

Figure 2C

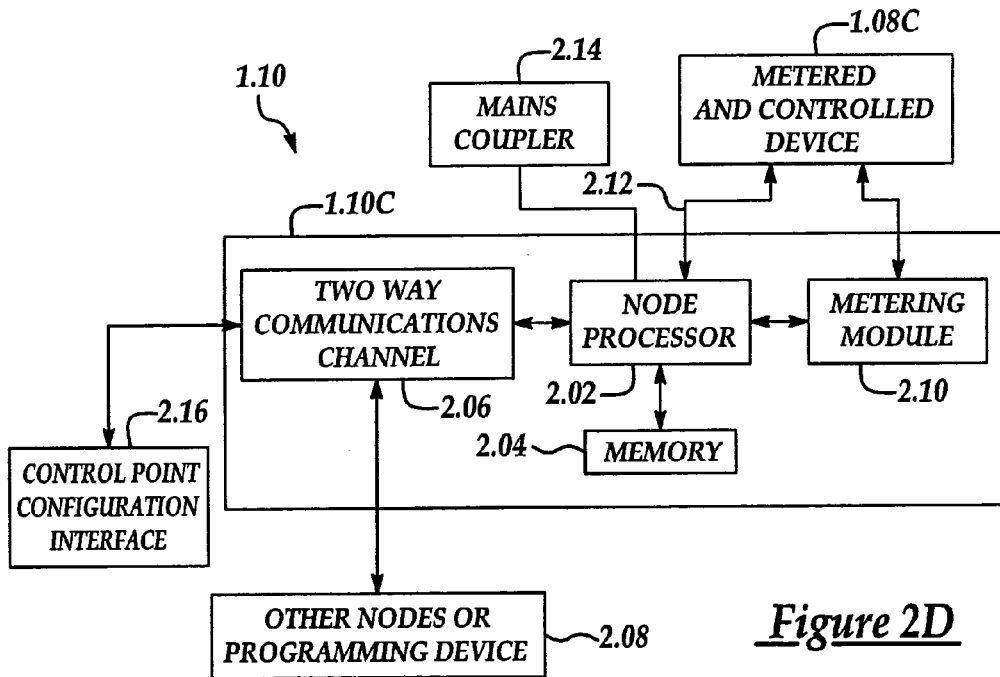

Figure 2D

Explore Litigation Insights

Docket Alarm provides insights to develop a more informed litigation strategy and the peace of mind of knowing you're on top of things.

Real-Time Litigation Alerts



Keep your litigation team up-to-date with **real-time alerts** and advanced team management tools built for the enterprise, all while greatly reducing PACER spend.

Our comprehensive service means we can handle Federal, State, and Administrative courts across the country.

Advanced Docket Research



With over 230 million records, Docket Alarm's cloud-native docket research platform finds what other services can't. Coverage includes Federal, State, plus PTAB, TTAB, ITC and NLRB decisions, all in one place.

Identify arguments that have been successful in the past with full text, pinpoint searching. Link to case law cited within any court document via Fastcase.

Analytics At Your Fingertips



Learn what happened the last time a particular judge, opposing counsel or company faced cases similar to yours.

Advanced out-of-the-box PTAB and TTAB analytics are always at your fingertips.

API

Docket Alarm offers a powerful API (application programming interface) to developers that want to integrate case filings into their apps.

LAW FIRMS

Build custom dashboards for your attorneys and clients with live data direct from the court.

Automate many repetitive legal tasks like conflict checks, document management, and marketing.

FINANCIAL INSTITUTIONS

Litigation and bankruptcy checks for companies and debtors.

E-DISCOVERY AND LEGAL VENDORS

Sync your system to PACER to automate legal marketing.