



[54] SYSTEM FOR JUST-IN-TIME RETRIEVAL OF MULTIMEDIA FILES OVER COMPUTER NETWORKS BY TRANSMITTING DATA PACKETS AT TRANSMISSION RATE DETERMINED BY FRAME SIZE

[75] Inventors: Huey-Shiang Chen; Mon-Song Chen, both of Katonah, N.Y.; Shiow-Laang Huang, Herndon, Va.; Deyang Song, Oradell, N.J.

[73] Assignee: Infovalue Computing, Inc., Elmsford, N.Y.

[21] Appl. No.: 505,488

[22] Filed: Jul. 21, 1995

[51] Int. Cl.⁶ G06F 13/00

[52] U.S. Cl. 395/200.33

[58] Field of Search 395/600, 200.33, 395/200.47, 200.49, 200.61, 200.76; 358/468; 370/60.1, 84, 94, 60; 364/200; 360/73; 235/375; 381/41; 375/13, 357; 348/7, 10, 12, 13, 14

[56] References Cited

U.S. PATENT DOCUMENTS

4,001,690	1/1977	Mack et al.	370/316
4,027,337	5/1977	De Loye et al.	360/73
4,051,530	9/1977	Kuroda et al.	348/415
4,606,044	8/1986	Kudo	375/13
4,630,196	12/1986	Bednar, Jr. et al.	364/200
4,729,020	3/1988	Schaphorst et al.	358/133
4,833,535	5/1989	Ozeki et al.	348/400
4,839,891	6/1989	Kobayashi et al.	370/94
5,025,457	6/1991	Ahmed	370/507
5,029,164	7/1991	Goldstein et al.	370/235
5,126,845	6/1992	Yamashita	358/160
5,136,655	8/1992	Bronson	381/41
5,208,810	5/1993	Park	370/230
5,237,156	8/1993	Konishi et al.	235/375
5,262,875	11/1993	Mincer et al.	348/6
5,319,638	6/1994	Lin	370/60
5,428,774	6/1995	Takahashi et al.	395/600
5,446,734	8/1995	Goldstein	370/397
5,457,687	10/1995	Newman	370/232

5,463,422	10/1995	Simpson et al.	348/390
5,491,565	2/1996	Naper	358/468
5,491,801	2/1996	Jain et al.	395/200.71
5,497,404	3/1996	Grover et al.	375/357
5,515,511	5/1996	Nguyen et al.	395/200.49
5,521,630	5/1996	Chen et al.	348/7
5,533,021	7/1996	Branstad et al.	370/60.1
5,541,919	7/1996	Yong et al.	370/61
5,544,170	8/1996	Kasahara	370/253
5,550,982	8/1996	Long et al.	395/200.13
5,566,175	10/1996	Davis	370/84
5,583,561	12/1996	Baker et al.	348/7
5,621,660	4/1997	Chaddha et al.	395/200.77
5,633,859	5/1997	Jain et al.	370/234
5,644,355	7/1997	Koz et al.	348/17
5,666,161	9/1997	Kohiyama et al.	348/408
5,721,878	2/1998	Ottesen et al.	348/7

FOREIGN PATENT DOCUMENTS

62-299148	12/1987	Japan	H04L 13/00
02-092153	3/1990	Japan	H04N 1/32
03-133255	6/1991	Japan	H04N 1/32
04-72838	3/1992	Japan	H04L 7/00
06-014080	1/1994	Japan	H04L 29/06

Primary Examiner—Moustafa M. Meky
Attorney, Agent, or Firm—Eliot S. Gerber

[57] ABSTRACT

A method in computer networks in which a client machine (playback client computer) requests multimedia files, such as compressed video clips, from a server (storage server computer). The transmission uses digital data packets. In the case of video files, the packet headers identify the video frame and the sequence number of each packet derived from the frame. The transmission timing is not based on a steady byte stream or an average of bytes to be transmitted. Instead, in the case of video, the frame rate determines normal transmission and a frame is transmitted during each frame time. The client agent has a normal packet buffer, normally holding 1-5 video frames. The transmission rate is adjusted to keep that buffer filled within its normal range. The timing information required for transmission, in one embodiment, is stored in a separate index file associated with each multimedia file.

42 Claims, 6 Drawing Sheets

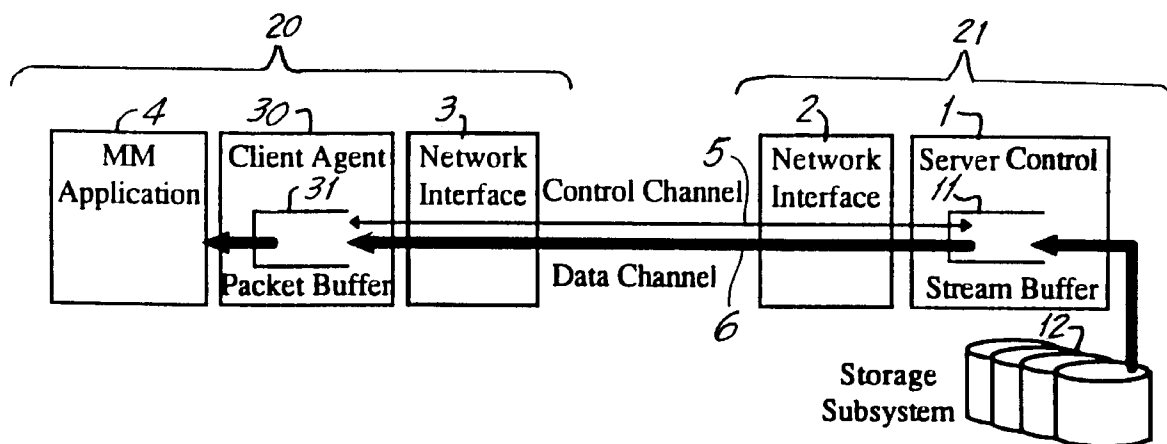

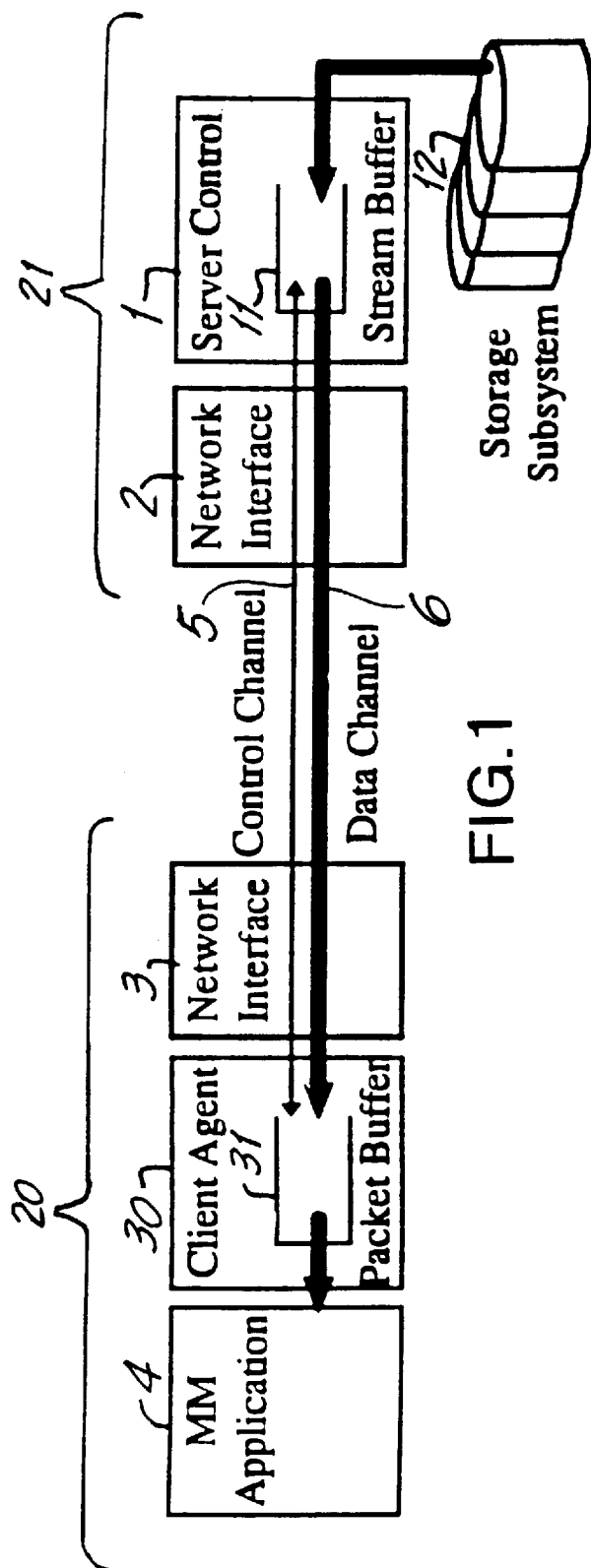

FIG. 1

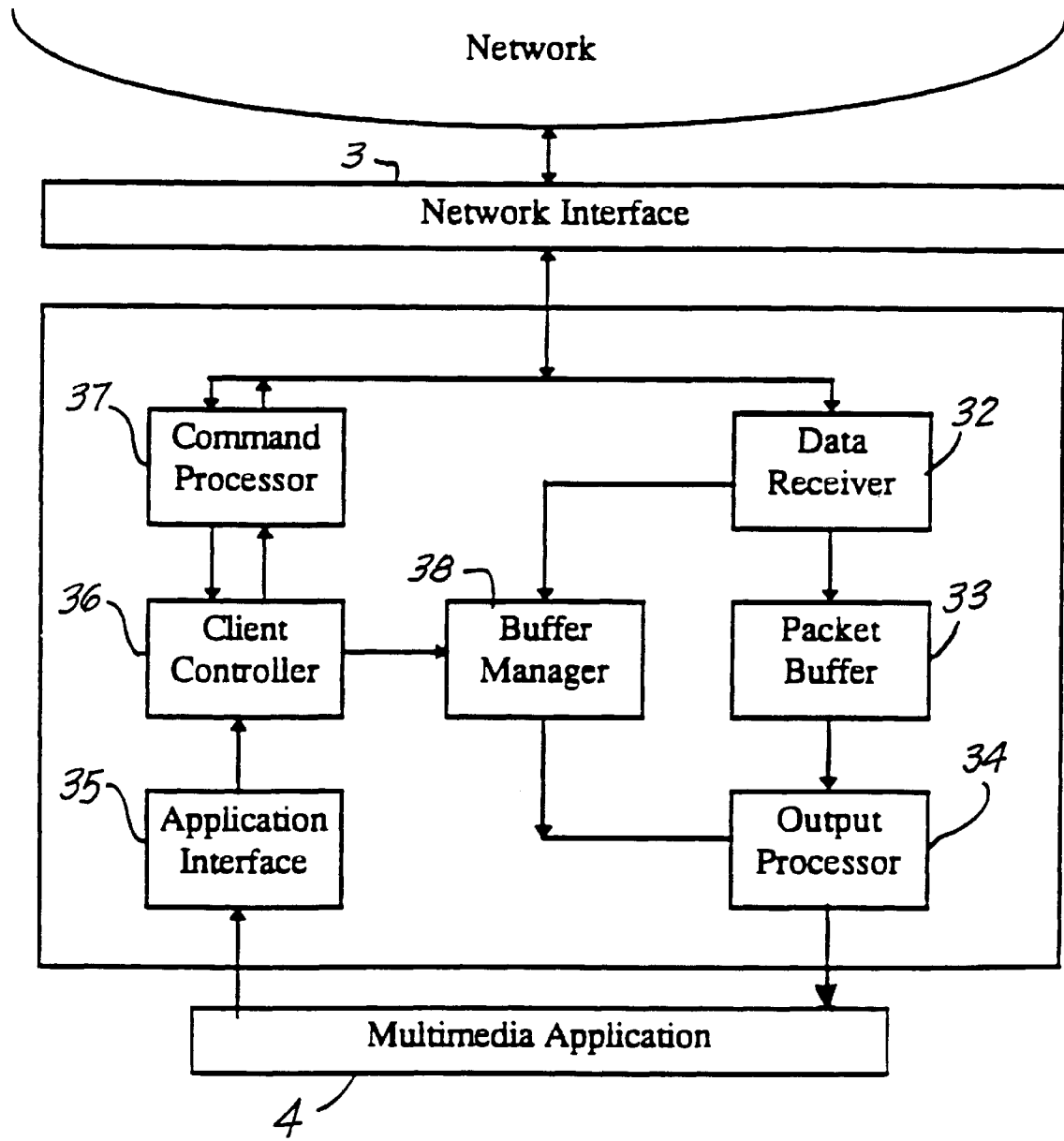

FIG.2

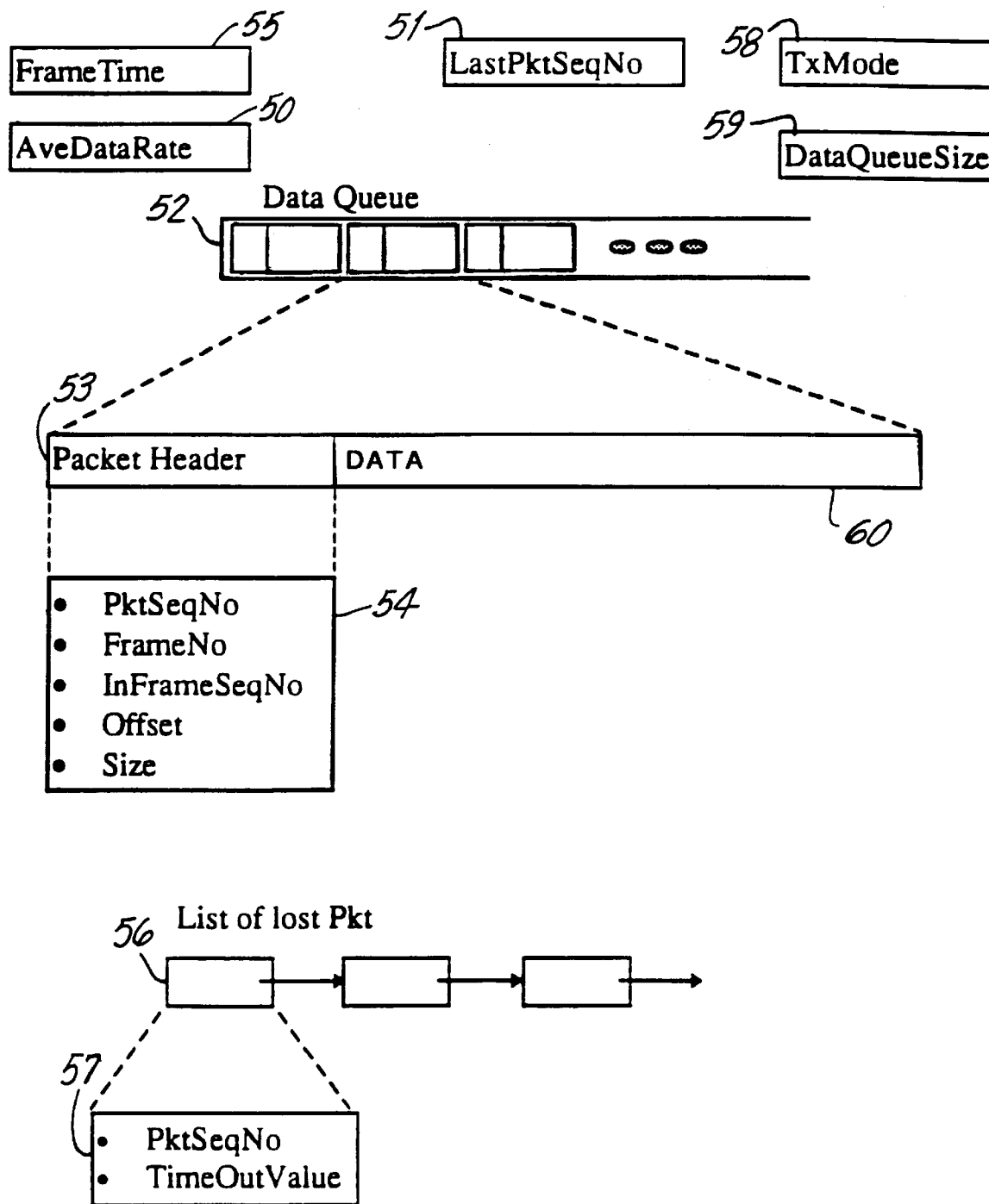

FIG.3

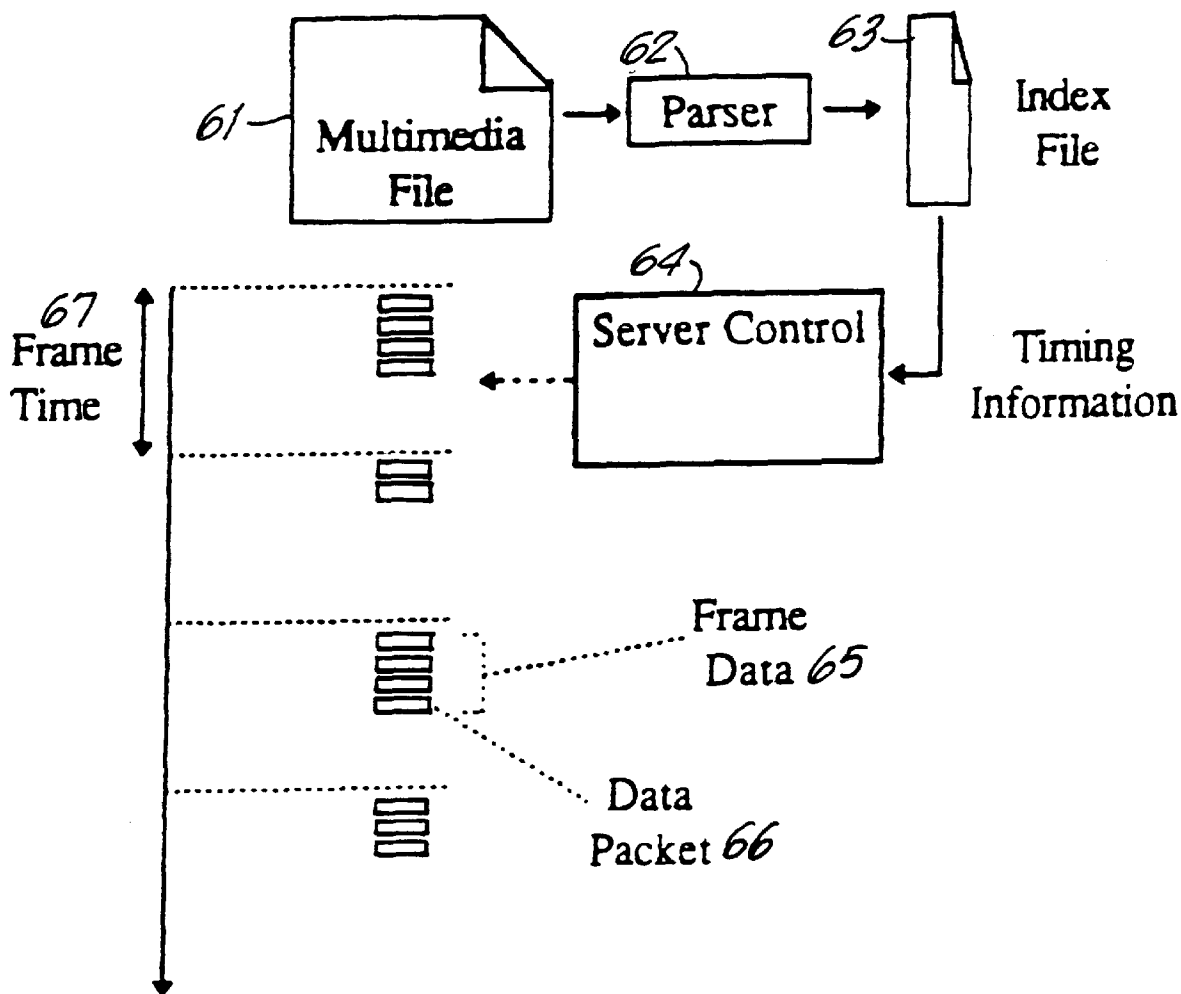

FIG.4

Explore Litigation Insights

Docket Alarm provides insights to develop a more informed litigation strategy and the peace of mind of knowing you're on top of things.

Real-Time Litigation Alerts



Keep your litigation team up-to-date with **real-time alerts** and advanced team management tools built for the enterprise, all while greatly reducing PACER spend.

Our comprehensive service means we can handle Federal, State, and Administrative courts across the country.

Advanced Docket Research



With over 230 million records, Docket Alarm's cloud-native docket research platform finds what other services can't. Coverage includes Federal, State, plus PTAB, TTAB, ITC and NLRB decisions, all in one place.

Identify arguments that have been successful in the past with full text, pinpoint searching. Link to case law cited within any court document via Fastcase.

Analytics At Your Fingertips



Learn what happened the last time a particular judge, opposing counsel or company faced cases similar to yours.

Advanced out-of-the-box PTAB and TTAB analytics are always at your fingertips.

API

Docket Alarm offers a powerful API (application programming interface) to developers that want to integrate case filings into their apps.

LAW FIRMS

Build custom dashboards for your attorneys and clients with live data direct from the court.

Automate many repetitive legal tasks like conflict checks, document management, and marketing.

FINANCIAL INSTITUTIONS

Litigation and bankruptcy checks for companies and debtors.

E-DISCOVERY AND LEGAL VENDORS

Sync your system to PACER to automate legal marketing.