



US006879823B1

(12) **United States Patent**
Raaf

(10) **Patent No.:** **US 6,879,823 B1**
(45) **Date of Patent:** **Apr. 12, 2005**

(54) **MOBILE STATION, BASE STATION AND METHOD FOR DATA TRANSMISSION IN A MOBILE RADIO SYSTEM**

(75) Inventor: **Bernhard Raaf**, Munich (DE)

(73) Assignee: **Siemens Aktiengesellschaft**, Munich (DE)

(*) Notice: Subject to any disclaimer, the term of this patent is extended or adjusted under 35 U.S.C. 154(b) by 0 days.

(21) Appl. No.: **09/831,179**

(22) PCT Filed: **Nov. 2, 1999**

(86) PCT No.: **PCT/DE99/03484**

§ 371 (c)(1),
(2), (4) Date: **May 4, 2001**

(87) PCT Pub. No.: **WO00/27150**

PCT Pub. Date: **May 11, 2000**

(30) **Foreign Application Priority Data**

Nov. 4, 1998 (DE) 198 50 866
Nov. 9, 1998 (DE) 198 51 600

(51) **Int. Cl.⁷** **H04B 17/00**

(52) **U.S. Cl.** **455/414; 455/53.1; 455/56.1; 455/115; 455/415; 455/67.1**

(58) **Field of Search** 455/414, 412, 455/413, 53.1, 56.1, 67.1; 375/316, 346, 348

(56) **References Cited**

U.S. PATENT DOCUMENTS

5,475,870 A * 12/1995 Weaver et al. 455/67.11
5,933,465 A * 8/1999 Ozaki 375/346
6,085,107 A * 7/2000 Persson et al. 455/522
6,389,300 B2 * 5/2002 Raaf 455/561

FOREIGN PATENT DOCUMENTS

WO WO 92/10886 6/1992
WO WO 94/29981 12/1994
WO WO 97/25827 7/1997

* cited by examiner

Primary Examiner—Allan Hoosain
(74) *Attorney, Agent, or Firm*—Bell Boyd & Lloyd LLC

(57) **ABSTRACT**

A mobile station, base station and method for data transmission in a mobile radio system, wherein for the purpose of observing GSM base stations, interruption phases are inserted in a UMTS transmission. To reduce the number of these interruption phases, the maximum effective duration of the interruption phases is chosen to be shorter than is needed under optimum transmission conditions for secure detection of a data packet which is to be detected and is sent from a GSM base station. A shrewd choice of parameters provides a better ratio of effort (effective duration of the interruption phase) to result (detection probability).

17 Claims, 2 Drawing Sheets

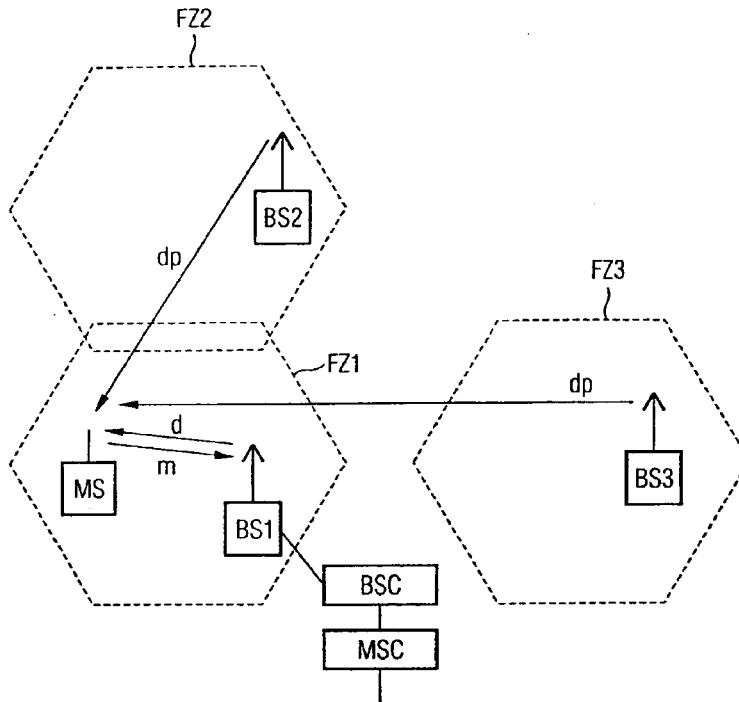

FIG 1

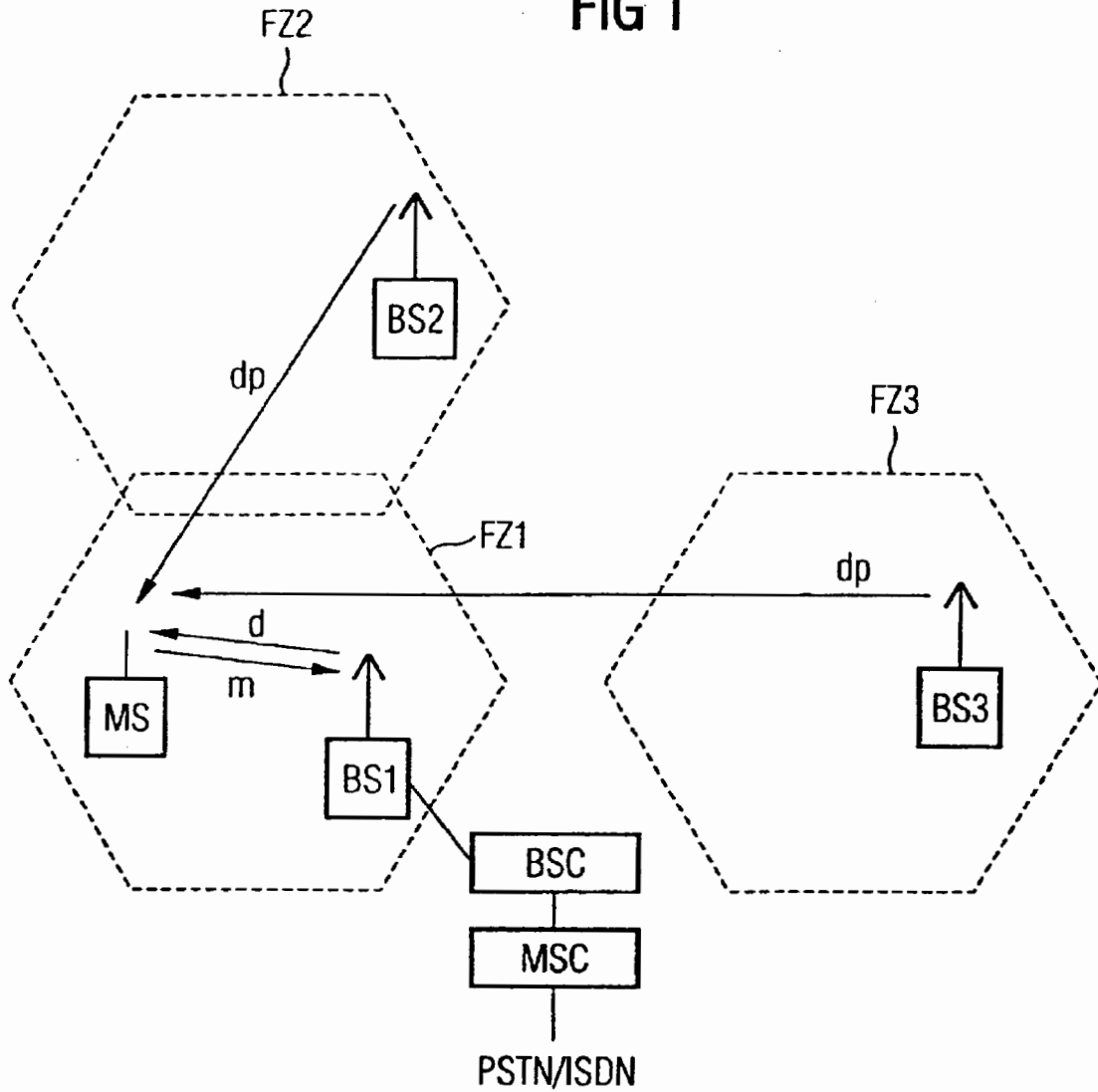

FIG 2

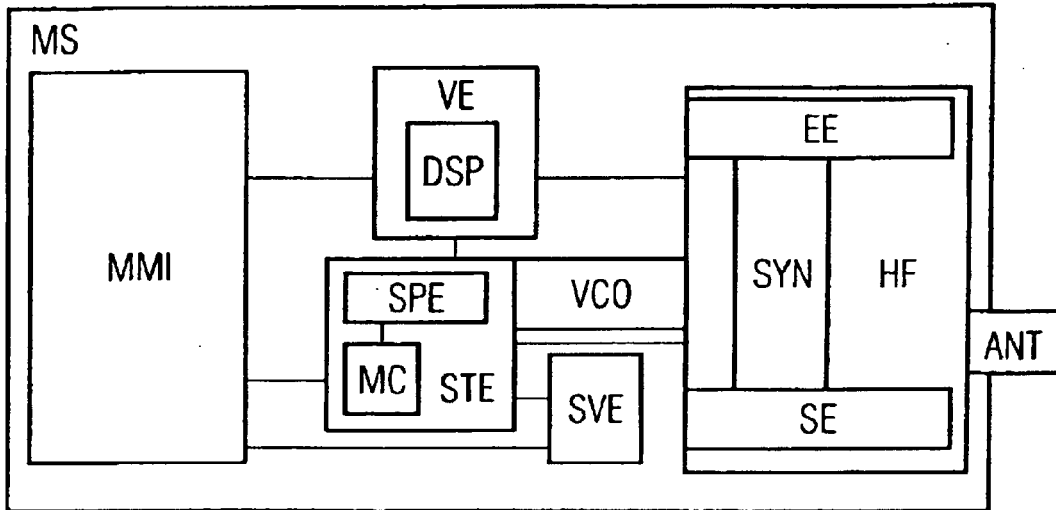
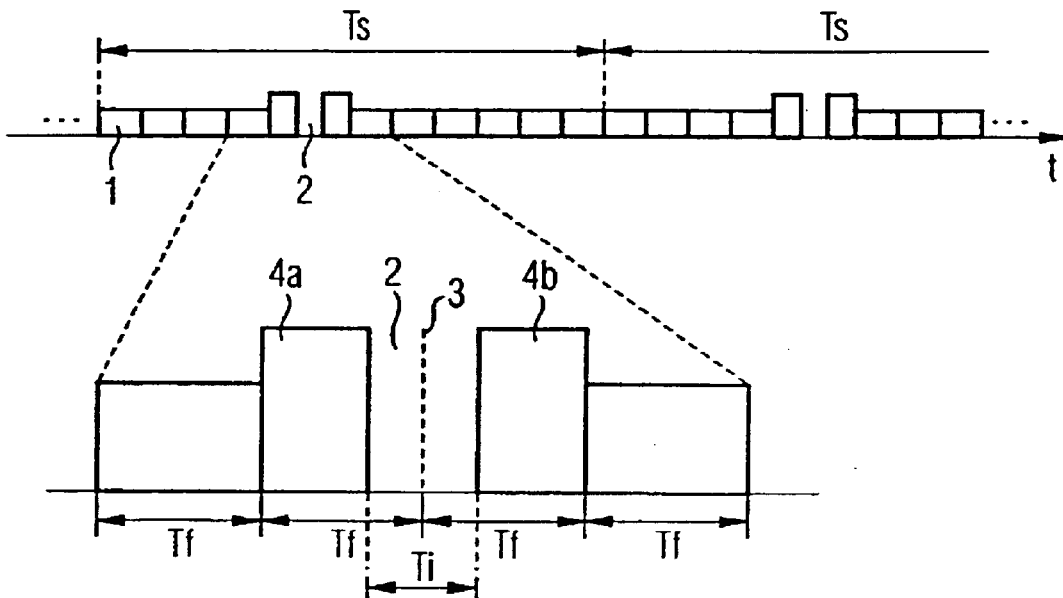

FIG 3



MOBILE STATION, BASE STATION AND METHOD FOR DATA TRANSMISSION IN A MOBILE RADIO SYSTEM

BACKGROUND OF THE INVENTION

1. Field of the Invention

The present invention relates to a base station, a mobile station and a method for data transmission in a communication system, in particular in a CDMA mobile radio system, where the data, structured in frames, is transmitted such that a mobile station is able to perform other functions; in particular, to carry out tests using a reception device, during one or more interruption phases in which it interrupts the reception (of the previous source or of the data from the base station) and/or the processing of received data or sending. "Transmission" is to be understood as sending and/or receiving below.

2. Description of the Prior Art

In communication systems, data (for example voice data, image data or system data) is transmitted on transmission links between base stations and mobile stations. In radio communication systems, this is done using electromagnetic waves via an air or radio interface. In this context, carrier frequencies are used which are situated in the frequency band provided for the respective system. In the case of the GSM (Global System for Mobile Communication), the carrier frequencies are in the range of 900 MHz. For future radio communication systems, for example the UMTS (Universal Mobile Telecommunication System) or other third generation systems, frequencies in the frequency band of 2000 MHz are provided.

Particularly in future CDMA systems, a base station basically sends continuously in the downlink direction, for example, that is to say in the direction from the base station to a mobile station. The data transmitted during sending is usually structured in frames which each have a prescribed length. Particularly with different services such as voice data transmission and video data transmission, the frames may also have different structures and lengths. The structure and/or length of each frame in a continuous series of frames is prescribed and/or is recognized by the mobile station, however.

Particularly in cellular mobile radio systems, the mobile station occasionally also needs to perform functions other than data reception which cannot be performed at the same time, at least during the operation of only a single reception device. By way of example, from time to time the mobile station in a radio communication system of cellular design in which the base stations in various cells send on different frequencies needs to test whether it is able to receive radio signals from another base station with good reception quality. For this purpose, the mobile station sets its reception device to a frequency other than the frequency on which it currently receives data.

In order to be able to send from the base station to the mobile station without interruption, it has already been proposed that the mobile station be equipped with a second reception device. In practice, however, this solution is usually rejected for cost reasons.

Another proposal is known according to which the base station interrupts sending at prescribed times in order to allow the receiving station to carry out an adjacent channel

packets also may be understood below to be synchronization, frequency correction or pilot signal bursts) using its individual reception device.

To prevent a loss of data, the base station sends the data beforehand at a higher transmission rate than the fundamentally constant permanent transmission rate. So that this does not result in higher bit error rates (BER), the transmission power additionally needs to be increased during this time.

The frequency at which the interruption phases recur and the length of the interruption phases depend on the particular system and also on the particular operating state of the system. By way of example, interruption phases each having a length of 5 to 6 ms, respectively, are sufficient for an adjacent channel search by a mobile station in a radio communication system organized on a cellular basis. WO-A-97 25827 discloses a method for data transmission, in which interruption phases for observing an adjacent base station are inserted during transmission. However, provision is made in this case for the interruption phases to be inserted at regular intervals, which entails the disadvantage that the efficiency of the data transmission is reduced with each interruption phase.

Since the losses in transmission quality also increase with the number of interruption phases inserted, it is desirable for the smallest possible number of interruption phases to be inserted.

By way of example, a GSM frame transmitted by the GSM base station contains eight timeslots which each contain a data packet. The data packets transmitted by the GSM base station BS2, such as synchronization data packets (data packets to be detected, synchronization burst), frequency correction data packets (characteristic data packets, frequency correction burst) and normal data packets, are all subordinate to the same time frame. The GSM base stations transmit all 10 time frames (GSM frames) 4 times and, after a subsequent 11 time frames (GSM frames) (51 time frames in total), a frequency correction data packet, and one respective time frame later, a synchronization data packet.

If interruption phases based on the GSM standard were now inserted with a period of 26 time frames (GSM frames), the fact that the period of 51 time frames and the period of 26 time frames have no common denominator would cause a cyclic shift in the two time frame periods, so that after a maximum of 11 times 26 time frames, that is to say after 11 observation frames, the sought data packet which is to be detected would be received if the mobile station is not too distant from the respective adjacent base station BS2, BS3 or if no interference which is too intense arises during transmission.

It is an object of the present invention, therefore, to specify a method for data transmission, a mobile station and a base station which permit second base stations to be reliably observed while transmission quality is good.

SUMMARY OF THE INVENTION

Accordingly, the present invention is based, in particular, on the concept of, contrary to the prior art, inserting interruption phases in which the mobile station interrupts the transmission, in particular the reception, of the data sent by the first base station and/or the processing of the received data not with a maximum effective total duration which would be needed under optimum transmission conditions for secure detection of a data packet which is to be detected, but instead inserting fewer and/or shorter interruption phases.

tive total duration of the interruption phases is shortened, contrary to the prior art, to a duration of a maximum of 9 or a maximum of 10 observation frames, the effective total duration of the interruption phases can be reduced by a much greater proportion than, in return, the theoretical detection probability for a data packet which is to be detected decreases. The effect of this is that the transmission quality from the first base station to a mobile station is improved, but in return the detection probability for a data packet which is to be detected remains comparatively high with respect thereto.

In this case, the data can be sent, by way of example, from the first base station to the mobile station, in which case, at least during particular transmission phases, interruption phases are inserted in which the first base station interrupts sending, and the mobile station interrupts the reception and/or the processing of received data, for example. In addition, the mobile station is switched to the reception of the characteristic data packets and/or data packets which are to be detected, which are sent cyclically by a second base station, and the maximum effective total duration of the interruption phases is shorter than would be needed under optimum transmission conditions for secure detection of a data packet which is to be detected.

The data packets sent by the second base station also may be data packets which are to be detected (synchronization data packets) or characteristic data packets (frequency correction data packets).

In this context, a first transmission method, used by a first base station, may be a CDMA method, and a second transmission method, used by a second base station, may be a GSM method.

Within the context of the application, GSM frame is also understood to be a frame which contains 8 time slots and has a duration of 4.6 ms.

Within the context of the application, observation frame is also understood to be a minimum time period required in order to observe a GSM frame. In this case, the exact duration of an observation frame is implementation-dependent; however, in order to ensure full detection of a GSM frame and to allow for the time needed for changing over the synthesizer frequency, it is generally longer than the duration of a GSM frame and may thus also have a duration of 9 time slots, 10 time slots (5.7 ms), 11 time slots or 12 time slots (6.9 ms).

Since many different variants are possible for inserting the interruption phases for the purpose of the adjacent channel search, the term "maximum effective total duration of the interruption phases" within the context of this application denotes the sum of all the interruption phases inserted as a maximum in order to observe an adjacent base station. However, this does not preclude further interruption phases from being inserted during subsequent repetition of the adjacent channel search, although a new effective total duration of the interruption phases is formed in this case. Under these circumstances, the individual interruption phases each may have the duration of an observation frame, but also may have any other duration. The duration of an interruption phase also may have a multiple or a fraction of the duration of an observation frame. It is also possible for the individual interruption phases to have different durations.

In one embodiment of the present invention, a period of 52 GSM frames lies between the start of a first interruption phase and the start of a second interruption phase.

reduced to 91%, with a mere loss of 2% needing to be accepted for the detection probability in return, as well as a halving of the search speed in comparison with the GSM search speed.

In another embodiment of the present invention, a period of 6 GSM frames is inserted between the start of a first interruption phase and the start of a first interruption phase and the start of a second interruption phase, and a period of 46 GSM frames is inserted between the start of a second interruption phase and the start of a third interruption phase.

In this case, simulations have been able to show that, at GSM search speed, the maximum effective total duration of the interruption phases can be reduced by 9% for a comparatively very small detection possibility loss of 2%.

In another embodiment of the present invention, the insertion of further interruption phases is ended, restricted or continued under control before the maximum effective total duration of the interruption phases is actually reached. To this end, after reception of a data packet which is to be detected or possibly of another data packet, indicating the end of the adjacent channel search, such as a characteristic data packet, an appropriate message is transmitted from the mobile station to the first base station.

Thus, while data is transmitted from a first base station to a mobile station in the downlink direction, for example, interruption phases are inserted, at least during particular send phases, in which the mobile station interrupts the reception of the data sent by the first base station and/or the processing of the received data and in which the mobile station is switched to the reception of data packets sent by a second base station. Depending on a reception result for these data packets sent by a second base station, information which influences the insertion of interruption phases is sent from the mobile station to the first base station.

In this way, it is possible for the insertion of interruption phases to be ended as soon as possible, and hence to be restricted as far as possible, as soon as sufficient information is known about the second base stations which are to be observed, and hence for the transmission quality to be improved. The effect of this is that the total duration of the interruption phases can be reduced further.

Additional features and advantages of the present invention are described in, and will be apparent from, the following Detailed Description of the Preferred Embodiments and the Drawings.

DESCRIPTION OF THE DRAWINGS

FIG. 1 shows a basic circuit diagram of a mobile radio system;

FIG. 2 shows a basic circuit diagram of a mobile station; and

FIG. 3 shows a schematic illustration of the insertion of interruption phases during a send phase.

DETAILED DESCRIPTION OF THE PREFERRED EMBODIMENTS

FIG. 1 shows a cellular mobile radio network including, by way of example, a combination of a GSM (Global System for Mobile Communication) system with a UMTS (Universal Mobile Telecommunication System) system, which includes a multiplicity of mobile switching centers MSC which are interlinked and set up access to a landline network PSTN/ISDN. In addition, these mobile switching centers MSC are connected to at least one respective base station.

Explore Litigation Insights

Docket Alarm provides insights to develop a more informed litigation strategy and the peace of mind of knowing you're on top of things.

Real-Time Litigation Alerts



Keep your litigation team up-to-date with **real-time alerts** and advanced team management tools built for the enterprise, all while greatly reducing PACER spend.

Our comprehensive service means we can handle Federal, State, and Administrative courts across the country.

Advanced Docket Research



With over 230 million records, Docket Alarm's cloud-native docket research platform finds what other services can't. Coverage includes Federal, State, plus PTAB, TTAB, ITC and NLRB decisions, all in one place.

Identify arguments that have been successful in the past with full text, pinpoint searching. Link to case law cited within any court document via Fastcase.

Analytics At Your Fingertips



Learn what happened the last time a particular judge, opposing counsel or company faced cases similar to yours.

Advanced out-of-the-box PTAB and TTAB analytics are always at your fingertips.

API

Docket Alarm offers a powerful API (application programming interface) to developers that want to integrate case filings into their apps.

LAW FIRMS

Build custom dashboards for your attorneys and clients with live data direct from the court.

Automate many repetitive legal tasks like conflict checks, document management, and marketing.

FINANCIAL INSTITUTIONS

Litigation and bankruptcy checks for companies and debtors.

E-DISCOVERY AND LEGAL VENDORS

Sync your system to PACER to automate legal marketing.