

AO 120 (Rev. 08/10)

TO: <b>Mail Stop 8 Director of the U.S. Patent and Trademark Office P.O. Box 1450 Alexandria, VA 22313-1450</b>	<b>REPORT ON THE FILING OR DETERMINATION OF AN ACTION REGARDING A PATENT OR TRADEMARK</b>
---	---

In Compliance with 35 U.S.C. § 290 and/or 15 U.S.C. § 1116 you are hereby advised that a court action has been filed in the U.S. District Court Western District of Texas on the following  
 Trademarks or  Patents. (  the patent action involves 35 U.S.C. § 292.):

DOCKET NO. <b>6:21-cv-694</b>	DATE FILED <b>7/1/2021</b>	U.S. DISTRICT COURT <b>Western District of Texas</b>
PLAINTIFF <b>XR COMMUNICATIONS, LLC, dba VIVATO TECHNOLOGIES</b>		DEFENDANT <b>HP INC.,</b>
PATENT OR TRADEMARK NO.	DATE OF PATENT OR TRADEMARK	HOLDER OF PATENT OR TRADEMARK
1 10,715,235	7/14/2020	XR Communications, LLC
2		
3		
4		
5		

In the above—entitled case, the following patent(s)/ trademark(s) have been included:

DATE INCLUDED	INCLUDED BY <input type="checkbox"/> Amendment <input type="checkbox"/> Answer <input type="checkbox"/> Cross Bill <input type="checkbox"/> Other Pleading	
PATENT OR TRADEMARK NO.	DATE OF PATENT OR TRADEMARK	HOLDER OF PATENT OR TRADEMARK
1		
2		
3		
4		
5		

In the above—entitled case, the following decision has been rendered or judgement issued:

DECISION/JUDGEMENT
--------------------

CLERK	(BY) DEPUTY CLERK	DATE
-------	-------------------	------

Copy 1—Upon initiation of action, mail this copy to Director Copy 3—Upon termination of action, mail this copy to Director  
 Copy 2—Upon filing document adding patent(s), mail this copy to Director Copy 4—Case file copy

**Print**

**Save As...**

**Reset**

**Samsung et al. v. XR Commc'ns.  
IPR2022-01362  
Exhibit 1002**

AO 120 (Rev. 08/10)

TO: <b>Mail Stop 8</b> <b>Director of the U.S. Patent and Trademark Office</b> <b>P.O. Box 1450</b> <b>Alexandria, VA 22313-1450</b>	<b>REPORT ON THE</b> <b>FILING OR DETERMINATION OF AN</b> <b>ACTION REGARDING A PATENT OR</b> <b>TRADEMARK</b>
---	---

In Compliance with 35 U.S.C. § 290 and/or 15 U.S.C. § 1116 you are hereby advised that a court action has been filed in the U.S. District Court Western District of Texas on the following

Trademarks or  Patents. (  the patent action involves 35 U.S.C. § 292.);

DOCKET NO. <b>6:21-cv-695</b>	DATE FILED 7/1/2021	U.S. DISTRICT COURT Western District of Texas
PLAINTIFF XR COMMUNICATIONS, LLC, dba VIVATO TECHNOLOGIES		DEFENDANT MICROSOFT CORPORATION,
PATENT OR TRADEMARK NO.	DATE OF PATENT OR TRADEMARK	HOLDER OF PATENT OR TRADEMARK
1 10,715,235	7/14/2020	XR Communications, LLC
2		
3		
4		
5		

In the above—entitled case, the following patent(s)/ trademark(s) have been included:

DATE INCLUDED	INCLUDED BY <input type="checkbox"/> Amendment <input type="checkbox"/> Answer <input type="checkbox"/> Cross Bill <input type="checkbox"/> Other Pleading	
PATENT OR TRADEMARK NO.	DATE OF PATENT OR TRADEMARK	HOLDER OF PATENT OR TRADEMARK
1		
2		
3		
4		
5		

In the above—entitled case, the following decision has been rendered or judgement issued:

DECISION/JUDGEMENT
--------------------

CLERK	(BY) DEPUTY CLERK	DATE
-------	-------------------	------

Copy 1—Upon initiation of action, mail this copy to Director Copy 3—Upon termination of action, mail this copy to Director  
 Copy 2—Upon filing document adding patent(s), mail this copy to Director Copy 4—Case file copy



AO 120 (Rev. 08/10)

TO: <b>Mail Stop 8</b> <b>Director of the U.S. Patent and Trademark Office</b> <b>P.O. Box 1450</b> <b>Alexandria, VA 22313-1450</b>	<b>REPORT ON THE</b> <b>FILING OR DETERMINATION OF AN</b> <b>ACTION REGARDING A PATENT OR</b> <b>TRADEMARK</b>
---	---

In Compliance with 35 U.S.C. § 290 and/or 15 U.S.C. § 1116 you are hereby advised that a court action has been filed in the U.S. District Court Western District of Texas on the following

Trademarks or  Patents. (  the patent action involves 35 U.S.C. § 292.);

DOCKET NO. 6:21-cv-619	DATE FILED 6/18/2021	U.S. DISTRICT COURT Western District of Texas
PLAINTIFF XR COMMUNICATIONS, LLC, dba VIVATO TECHNOLOGIES		DEFENDANT AMAZON.COM, INC., AMAZON.COM SERVICES LLC, EERO LLC
PATENT OR TRADEMARK NO.	DATE OF PATENT OR TRADEMARK	HOLDER OF PATENT OR TRADEMARK
1 10,715,235	7/14/2020	XR Communications, LLC
2 10,594,376	3/17/2020	XR Communications, LLC
3	Format m/d/yyyy	
4		
5		

In the above—entitled case, the following patent(s)/ trademark(s) have been included:

DATE INCLUDED	INCLUDED BY <input type="checkbox"/> Amendment <input type="checkbox"/> Answer <input type="checkbox"/> Cross Bill <input type="checkbox"/> Other Pleading	
PATENT OR TRADEMARK NO.	DATE OF PATENT OR TRADEMARK	HOLDER OF PATENT OR TRADEMARK
1		
2		
3		
4		
5		

In the above—entitled case, the following decision has been rendered or judgement issued:

DECISION/JUDGEMENT
--------------------

CLERK	(BY) DEPUTY CLERK	DATE
-------	-------------------	------

Copy 1—Upon initiation of action, mail this copy to Director Copy 3—Upon termination of action, mail this copy to Director  
 Copy 2—Upon filing document adding patent(s), mail this copy to Director Copy 4—Case file copy



AO 120 (Rev. 08/10)

TO: <b>Mail Stop 8</b> <b>Director of the U.S. Patent and Trademark Office</b> <b>P.O. Box 1450</b> <b>Alexandria, VA 22313-1450</b>	<b>REPORT ON THE</b> <b>FILING OR DETERMINATION OF AN</b> <b>ACTION REGARDING A PATENT OR</b> <b>TRADEMARK</b>
---	---

In Compliance with 35 U.S.C. § 290 and/or 15 U.S.C. § 1116 you are hereby advised that a court action has been filed in the U.S. District Court Western District of Texas on the following

Trademarks or  Patents. (  the patent action involves 35 U.S.C. § 292.);

DOCKET NO. 6:21-cv-00646	DATE FILED 6/22/2021	U.S. DISTRICT COURT Western District of Texas
PLAINTIFF XR COMMUNICATIONS, LLC, dba VIVATO TECHNOLOGIES		DEFENDANT DELL TECHNOLOGIES INC. AND DELL INC.
PATENT OR TRADEMARK NO.	DATE OF PATENT OR TRADEMARK	HOLDER OF PATENT OR TRADEMARK
1 10,715,235	7/14/2020	XR Communications, LLC
2	Format m/d/yyyy	
3		
4		
5		

In the above—entitled case, the following patent(s)/ trademark(s) have been included:

DATE INCLUDED	INCLUDED BY <input type="checkbox"/> Amendment <input type="checkbox"/> Answer <input type="checkbox"/> Cross Bill <input type="checkbox"/> Other Pleading	
PATENT OR TRADEMARK NO.	DATE OF PATENT OR TRADEMARK	HOLDER OF PATENT OR TRADEMARK
1		
2		
3		
4		
5		

In the above—entitled case, the following decision has been rendered or judgement issued:

DECISION/JUDGEMENT
--------------------

CLERK	(BY) DEPUTY CLERK	DATE
-------	-------------------	------

Copy 1—Upon initiation of action, mail this copy to Director Copy 3—Upon termination of action, mail this copy to Director  
 Copy 2—Upon filing document adding patent(s), mail this copy to Director Copy 4—Case file copy



AO 120 (Rev. 08/10)

TO: <b>Mail Stop 8</b> <b>Director of the U.S. Patent and Trademark Office</b> <b>P.O. Box 1450</b> <b>Alexandria, VA 22313-1450</b>	<b>REPORT ON THE</b> <b>FILING OR DETERMINATION OF AN</b> <b>ACTION REGARDING A PATENT OR</b> <b>TRADEMARK</b>
---	---

In Compliance with 35 U.S.C. § 290 and/or 15 U.S.C. § 1116 you are hereby advised that a court action has been filed in the U.S. District Court Western District of Texas on the following

Trademarks or  Patents. (  the patent action involves 35 U.S.C. § 292.);

DOCKET NO. 6:21-CV-00619	DATE FILED 6/16/2021	U.S. DISTRICT COURT Western District of Texas
PLAINTIFF XR COMMUNICATIONS, LLC, dba VIVATO TECHNOLOGIES		DEFENDANT AMAZON.COM, INC., AMAZON.COM SERVICES LLC, EERO LLC, AND RING LLC
PATENT OR TRADEMARK NO.	DATE OF PATENT OR TRADEMARK	HOLDER OF PATENT OR TRADEMARK
1 10,715,235	7/14/2020	XR Communications, LLC
2 10,594,376	3/17/2020	XR Communications, LLC
3	Format m/d/yyyy	
4		
5		

In the above—entitled case, the following patent(s)/ trademark(s) have been included:

DATE INCLUDED	INCLUDED BY <input type="checkbox"/> Amendment <input type="checkbox"/> Answer <input type="checkbox"/> Cross Bill <input type="checkbox"/> Other Pleading	
PATENT OR TRADEMARK NO.	DATE OF PATENT OR TRADEMARK	HOLDER OF PATENT OR TRADEMARK
1		
2		
3		
4		
5		

In the above—entitled case, the following decision has been rendered or judgement issued:

DECISION/JUDGEMENT
--------------------

CLERK	(BY) DEPUTY CLERK	DATE
-------	-------------------	------

Copy 1—Upon initiation of action, mail this copy to Director Copy 3—Upon termination of action, mail this copy to Director  
 Copy 2—Upon filing document adding patent(s), mail this copy to Director Copy 4—Case file copy



AO 120 (Rev. 08/10)

TO: <b>Mail Stop 8</b> <b>Director of the U.S. Patent and Trademark Office</b> <b>P.O. Box 1450</b> <b>Alexandria, VA 22313-1450</b>	<b>REPORT ON THE</b> <b>FILING OR DETERMINATION OF AN</b> <b>ACTION REGARDING A PATENT OR</b> <b>TRADEMARK</b>
---	---

In Compliance with 35 U.S.C. § 290 and/or 15 U.S.C. § 1116 you are hereby advised that a court action has been filed in the U.S. District Court Western District of Texas on the following

Trademarks or  Patents. (  the patent action involves 35 U.S.C. § 292.);

DOCKET NO.	DATE FILED 6/16/2021	U.S. DISTRICT COURT Western District of Texas
PLAINTIFF XR COMMUNICATIONS, LLC, dba VIVATO TECHNOLOGIES		DEFENDANT APPLE, INC.
PATENT OR TRADEMARK NO.	DATE OF PATENT OR TRADEMARK	HOLDER OF PATENT OR TRADEMARK
1 10,715,235	7/14/2020	XR Communications, LLC
2		
3		
4		
5		

In the above—entitled case, the following patent(s)/ trademark(s) have been included:

DATE INCLUDED	INCLUDED BY	<input type="checkbox"/> Amendment <input type="checkbox"/> Answer <input type="checkbox"/> Cross Bill <input type="checkbox"/> Other Pleading
PATENT OR TRADEMARK NO.	DATE OF PATENT OR TRADEMARK	HOLDER OF PATENT OR TRADEMARK
1		
2		
3		
4		
5		

In the above—entitled case, the following decision has been rendered or judgement issued:

DECISION/JUDGEMENT
--------------------

CLERK	(BY) DEPUTY CLERK	DATE
-------	-------------------	------

Copy 1—Upon initiation of action, mail this copy to Director    Copy 3—Upon termination of action, mail this copy to Director  
 Copy 2—Upon filing document adding patent(s), mail this copy to Director    Copy 4—Case file copy



AO 120 (Rev. 08/10)

TO: <b>Mail Stop 8</b> <b>Director of the U.S. Patent and Trademark Office</b> <b>P.O. Box 1450</b> <b>Alexandria, VA 22313-1450</b>	<b>REPORT ON THE</b> <b>FILING OR DETERMINATION OF AN</b> <b>ACTION REGARDING A PATENT OR</b> <b>TRADEMARK</b>
---	---

In Compliance with 35 U.S.C. § 290 and/or 15 U.S.C. § 1116 you are hereby advised that a court action has been filed in the U.S. District Court Western District of Texas on the following

Trademarks or  Patents. (  the patent action involves 35 U.S.C. § 292.);

DOCKET NO.	DATE FILED 6/16/2021	U.S. DISTRICT COURT Western District of Texas
PLAINTIFF XR COMMUNICATIONS, LLC, dba VIVATO TECHNOLOGIES		DEFENDANT ASUSTEK COMPUTER INC.
PATENT OR TRADEMARK NO.	DATE OF PATENT OR TRADEMARK	HOLDER OF PATENT OR TRADEMARK
1 7,729,728	6/1/2010	XR Communications, LLC
2 10,594,376	3/17/2020	XR Communications, LLC
3 10,715,235	7/14/2020	XR Communications, LLC
4		
5		

In the above—entitled case, the following patent(s)/ trademark(s) have been included:

DATE INCLUDED	INCLUDED BY	<input type="checkbox"/> Amendment <input type="checkbox"/> Answer <input type="checkbox"/> Cross Bill <input type="checkbox"/> Other Pleading
PATENT OR TRADEMARK NO.	DATE OF PATENT OR TRADEMARK	HOLDER OF PATENT OR TRADEMARK
1		
2		
3		
4		
5		

In the above—entitled case, the following decision has been rendered or judgement issued:

DECISION/JUDGEMENT
--------------------

CLERK	(BY) DEPUTY CLERK	DATE
-------	-------------------	------

Copy 1—Upon initiation of action, mail this copy to Director    Copy 3—Upon termination of action, mail this copy to Director  
 Copy 2—Upon filing document adding patent(s), mail this copy to Director    Copy 4—Case file copy



AO 120 (Rev. 08/10)

TO: <b>Mail Stop 8</b> <b>Director of the U.S. Patent and Trademark Office</b> <b>P.O. Box 1450</b> <b>Alexandria, VA 22313-1450</b>	<b>REPORT ON THE</b> <b>FILING OR DETERMINATION OF AN</b> <b>ACTION REGARDING A PATENT OR</b> <b>TRADEMARK</b>
---	---

In Compliance with 35 U.S.C. § 290 and/or 15 U.S.C. § 1116 you are hereby advised that a court action has been filed in the U.S. District Court Western District of Texas on the following

Trademarks or  Patents. (  the patent action involves 35 U.S.C. § 292.);

DOCKET NO. 6:21-cv-625	DATE FILED 6/16/2021	U.S. DISTRICT COURT Western District of Texas
PLAINTIFF XR COMMUNICATIONS, LLC, dba VIVATO TECHNOLOGIES		DEFENDANT GOOGLE LLC
PATENT OR TRADEMARK NO.	DATE OF PATENT OR TRADEMARK	HOLDER OF PATENT OR TRADEMARK
1 10,715,235	7/14/2020	XR Communications, LLC
2 10,594,376	3/17/2020	XR Communications, LLC
3		
4		
5		

In the above—entitled case, the following patent(s)/ trademark(s) have been included:

DATE INCLUDED	INCLUDED BY <input type="checkbox"/> Amendment <input type="checkbox"/> Answer <input type="checkbox"/> Cross Bill <input type="checkbox"/> Other Pleading	
PATENT OR TRADEMARK NO.	DATE OF PATENT OR TRADEMARK	HOLDER OF PATENT OR TRADEMARK
1		
2		
3		
4		
5		

In the above—entitled case, the following decision has been rendered or judgement issued:

DECISION/JUDGEMENT
--------------------

CLERK	(BY) DEPUTY CLERK	DATE
-------	-------------------	------

Copy 1—Upon initiation of action, mail this copy to Director Copy 3—Upon termination of action, mail this copy to Director  
 Copy 2—Upon filing document adding patent(s), mail this copy to Director Copy 4—Case file copy





AO 120 (Rev. 08/10)

TO: <b>Mail Stop 8</b> <b>Director of the U.S. Patent and Trademark Office</b> <b>P.O. Box 1450</b> <b>Alexandria, VA 22313-1450</b>	<b>REPORT ON THE</b> <b>FILING OR DETERMINATION OF AN</b> <b>ACTION REGARDING A PATENT OR</b> <b>TRADEMARK</b>
---	---

In Compliance with 35 U.S.C. § 290 and/or 15 U.S.C. § 1116 you are hereby advised that a court action has been filed in the U.S. District Court Western District of Texas on the following

Trademarks or  Patents. (  the patent action involves 35 U.S.C. § 292.);

DOCKET NO. 6:21-cv-619	DATE FILED 6/18/2021	U.S. DISTRICT COURT Western District of Texas
PLAINTIFF XR COMMUNICATIONS, LLC, dba VIVATO TECHNOLOGIES		DEFENDANT AMAZON.COM, INC., AMAZON.COM SERVICES LLC, EERO LLC
PATENT OR TRADEMARK NO.	DATE OF PATENT OR TRADEMARK	HOLDER OF PATENT OR TRADEMARK
1 10,715,235	7/14/2020	XR Communications, LLC
2 10,594,376	3/17/2020	XR Communications, LLC
3	Format m/d/yyyy	
4		
5		

In the above—entitled case, the following patent(s)/ trademark(s) have been included:

DATE INCLUDED	INCLUDED BY <input type="checkbox"/> Amendment <input type="checkbox"/> Answer <input type="checkbox"/> Cross Bill <input type="checkbox"/> Other Pleading	
PATENT OR TRADEMARK NO.	DATE OF PATENT OR TRADEMARK	HOLDER OF PATENT OR TRADEMARK
1		
2		
3		
4		
5		

In the above—entitled case, the following decision has been rendered or judgement issued:

DECISION/JUDGEMENT
--------------------

CLERK	(BY) DEPUTY CLERK	DATE
-------	-------------------	------

Copy 1—Upon initiation of action, mail this copy to Director Copy 3—Upon termination of action, mail this copy to Director  
 Copy 2—Upon filing document adding patent(s), mail this copy to Director Copy 4—Case file copy



AO 120 (Rev. 08/10)

TO: <b>Mail Stop 8</b> <b>Director of the U.S. Patent and Trademark Office</b> <b>P.O. Box 1450</b> <b>Alexandria, VA 22313-1450</b>	<b>REPORT ON THE</b> <b>FILING OR DETERMINATION OF AN</b> <b>ACTION REGARDING A PATENT OR</b> <b>TRADEMARK</b>
---	---

In Compliance with 35 U.S.C. § 290 and/or 15 U.S.C. § 1116 you are hereby advised that a court action has been filed in the U.S. District Court Western District of Texas on the following

Trademarks or  Patents. (  the patent action involves 35 U.S.C. § 292.);

DOCKET NO. 6:21-cv-626	DATE FILED 6/16/2021	U.S. DISTRICT COURT Western District of Texas
PLAINTIFF XR COMMUNICATIONS, LLC, dba VIVATO TECHNOLOGIES		DEFENDANT SAMSUNG ELECTRONICS CO., LTD. AND SAMSUNG ELECTRONICS AMERICA, INC
PATENT OR TRADEMARK NO.	DATE OF PATENT OR TRADEMARK	HOLDER OF PATENT OR TRADEMARK
1 10,715,235	7/14/2020	XR Communications, LLC
2 10,594,376	3/17/2020	XR Communications, LLC
3		
4		
5		

In the above—entitled case, the following patent(s)/ trademark(s) have been included:

DATE INCLUDED	INCLUDED BY <input type="checkbox"/> Amendment <input type="checkbox"/> Answer <input type="checkbox"/> Cross Bill <input type="checkbox"/> Other Pleading	
PATENT OR TRADEMARK NO.	DATE OF PATENT OR TRADEMARK	HOLDER OF PATENT OR TRADEMARK
1		
2		
3		
4		
5		

In the above—entitled case, the following decision has been rendered or judgement issued:

DECISION/JUDGEMENT
--------------------

CLERK	(BY) DEPUTY CLERK	DATE
-------	-------------------	------

Copy 1—Upon initiation of action, mail this copy to Director Copy 3—Upon termination of action, mail this copy to Director  
 Copy 2—Upon filing document adding patent(s), mail this copy to Director Copy 4—Case file copy





# UNITED STATES PATENT AND TRADEMARK OFFICE

UNITED STATES DEPARTMENT OF COMMERCE  
United States Patent and Trademark Office  
Address: COMMISSIONER FOR PATENTS  
P.O. Box 1450  
Alexandria, Virginia 22313-1450  
[www.uspto.gov](http://www.uspto.gov)

APPLICATION NO.	ISSUE DATE	PATENT NO.	ATTORNEY DOCKET NO.	CONFIRMATION NO.
15/495,539	07/14/2020	10715235	1640-001.203	1050

22145 7590 06/24/2020  
KLEIN, O'NEILL & SINGH, LLP  
16755 VON KARMAN AVENUE  
SUITE 275  
IRVINE, CA 92606

## ISSUE NOTIFICATION

The projected patent number and issue date are specified above.

### **Determination of Patent Term Adjustment under 35 U.S.C. 154 (b)** (application filed on or after May 29, 2000)

The Patent Term Adjustment is 0 day(s). Any patent to issue from the above-identified application will include an indication of the adjustment on the front page.

If a Continued Prosecution Application (CPA) was filed in the above-identified application, the filing date that determines Patent Term Adjustment is the filing date of the most recent CPA.

Applicant will be able to obtain more detailed information by accessing the Patent Application Information Retrieval (PAIR) WEB site (<http://pair.uspto.gov>).

Any questions regarding the Patent Term Extension or Adjustment determination should be directed to the Office of Patent Legal Administration at (571)-272-7702. Questions relating to issue and publication fee payments should be directed to the Application Assistance Unit (AAU) of the Office of Data Management (ODM) at (571)-272-4200.

APPLICANT(s) (Please see PAIR WEB site <http://pair.uspto.gov> for additional applicants):

Marcus Da Silva, Spokane, WA;  
XR Communications, LLC D/B/A Vivato Technologies, Solana Beach, CA;  
William J. Crilly JR., Liberty Lake, WA;  
James Brennan, Sammamish, WA;  
Robert J. Conley, Liberty Lake, WA;  
Siavash Alamouti, Spokane, WA;  
Eduardo Casas, Vancouver, CANADA;  
Hujun Yin, Spokane, WA;  
Bobby Jose, Veradale, WA;  
Yang-Seok Choi, Liberty Lake, WA;  
Vahid Tarokh, Cambridge, MA;  
Praveen Mehrotra, Spokane, WA;

The United States represents the largest, most dynamic marketplace in the world and is an unparalleled location for business investment, innovation, and commercialization of new technologies. The USA offers tremendous resources and advantages for those who invest and manufacture goods here. Through SelectUSA, our nation works to encourage and facilitate business investment. To learn more about why the USA is the best country in the world to develop technology, manufacture products, and grow your business, visit [SelectUSA.gov](http://SelectUSA.gov).

IR103 (Rev. 10/09)



UNITED STATES PATENT AND TRADEMARK OFFICE

UNITED STATES DEPARTMENT OF COMMERCE  
**United States Patent and Trademark Office**  
Address: COMMISSIONER FOR PATENTS  
P.O. Box 1450  
Alexandria, Virginia 22313-1450  
www.uspto.gov

APPLICATION NO.	FILING DATE	FIRST NAMED INVENTOR	ATTORNEY DOCKET NO.	CONFIRMATION NO.
15/495,539	04/24/2017	Marcus Da Silva	1640-001.203	1050
22145	7590	06/17/2020	EXAMINER	
KLEIN, O'NEILL & SINGH, LLP 16755 VON KARMAN AVENUE SUITE 275 IRVINE, CA 92606			MCKIE, GINA M	
			ART UNIT	PAPER NUMBER
			2631	
			NOTIFICATION DATE	DELIVERY MODE
			06/17/2020	ELECTRONIC

**Please find below and/or attached an Office communication concerning this application or proceeding.**

The time period for reply, if any, is set in the attached communication.

Notice of the Office communication was sent electronically on above-indicated "Notification Date" to the following e-mail address(es):

KOS\_Docketing@koslaw.com

<b>Supplemental Notice of Allowability</b>	<b>Application No.</b> 15/495,539	<b>Applicant(s)</b> Da Silva et al.	
	<b>Examiner</b> GINA M MCKIE	<b>Art Unit</b> 2631	<b>AIA (FITF) Status</b> No

**-- The MAILING DATE of this communication appears on the cover sheet with the correspondence address--**

All claims being allowable, PROSECUTION ON THE MERITS IS (OR REMAINS) CLOSED in this application. If not included herewith (or previously mailed), a Notice of Allowance (PTOL-85) or other appropriate communication will be mailed in due course. **THIS NOTICE OF ALLOWABILITY IS NOT A GRANT OF PATENT RIGHTS.** This application is subject to withdrawal from issue at the initiative of the Office or upon petition by the applicant. See 37 CFR 1.313 and MPEP 1308.

- 1.  This communication is responsive to the IDS filed June 05, 2020.
  - A declaration(s)/affidavit(s) under **37 CFR 1.130(b)** was/were filed on \_\_\_\_\_.
- 2.  An election was made by the applicant in response to a restriction requirement set forth during the interview on \_\_\_\_\_; the restriction requirement and election have been incorporated into this action.
- 3.  The allowed claim(s) is/are 2-8,10-18 and 21-23 . As a result of the allowed claim(s), you may be eligible to benefit from the **Patent Prosecution Highway** program at a participating intellectual property office for the corresponding application. For more information , please see [http://www.uspto.gov/patents/init\\_events/pph/index.jsp](http://www.uspto.gov/patents/init_events/pph/index.jsp) or send an inquiry to [PPHfeedback@uspto.gov](mailto:PPHfeedback@uspto.gov).
- 4.  Acknowledgment is made of a claim for foreign priority under 35 U.S.C. § 119(a)-(d) or (f).

**Certified copies:**

- a)  All      b)  Some      \*c)  None of the:
  - 1.  Certified copies of the priority documents have been received.
  - 2.  Certified copies of the priority documents have been received in Application No. \_\_\_\_\_ .
  - 3.  Copies of the certified copies of the priority documents have been received in this national stage application from the International Bureau (PCT Rule 17.2(a)).

\* Certified copies not received: \_\_\_\_\_ .

Applicant has THREE MONTHS FROM THE "MAILING DATE" of this communication to file a reply complying with the requirements noted below. Failure to timely comply will result in ABANDONMENT of this application.

**THIS THREE-MONTH PERIOD IS NOT EXTENDABLE.**

- 5.  CORRECTED DRAWINGS (as "replacement sheets") must be submitted.
  - including changes required by the attached Examiner's Amendment / Comment or in the Office action of Paper No./Mail Date \_\_\_\_\_ .

**Identifying indicia such as the application number (see 37 CFR 1.84(c)) should be written on the drawings in the front (not the back) of each sheet. Replacement sheet(s) should be labeled as such in the header according to 37 CFR 1.121(d).**
- 6.  DEPOSIT OF and/or INFORMATION about the deposit of BIOLOGICAL MATERIAL must be submitted. Note the attached Examiner's comment regarding REQUIREMENT FOR THE DEPOSIT OF BIOLOGICAL MATERIAL.

**Attachment(s)**

- 1.  Notice of References Cited (PTO-892)
- 2.  Information Disclosure Statements (PTO/SB/08), Paper No./Mail Date \_\_\_\_\_.
- 3.  Examiner's Comment Regarding Requirement for Deposit of Biological Material \_\_\_\_\_.
- 4.  Interview Summary (PTO-413), Paper No./Mail Date \_\_\_\_\_.
- 5.  Examiner's Amendment/Comment
- 6.  Examiner's Statement of Reasons for Allowance
- 7.  Other \_\_\_\_\_.

/GINA M MCKIE/ Examiner, Art Unit 2631	/SHUWANG LIU/ Supervisory Patent Examiner, Art Unit 2631
---	---

PTO/SB/08 Equivalent

<b>INFORMATION DISCLOSURE STATEMENT BY APPLICANT</b>	Application No.	15/495,539	
	Filing Date	April 24, 2017	
	First Named Inventor	Marcus Da Silva	
	Art Unit	2631	
<i>(Multiple sheets used when necessary)</i>		Examiner	McKie, Gina M.
SHEET 1 OF 2		Attorney Docket No.	1640-001.203

U.S. PATENT DOCUMENTS					
Examiner Initials	Cite No.	Document Number <i>Number - Kind Code (if known)</i> Example: 1,234,567 B1	Publication Date MM-DD-YYYY	Name of Patentee or Applicant	Pages, Columns, Lines Where Relevant Passages or Relevant Figures Appear
	1	5,933,421 A	08-03-1999	Alamouti et al.	
	2	6,414,986 B1	07-02-2002	Usui	
	3	6,982,968 B1	01-03-2006	Barratt et al.	
	4	8,412,106 B2	04-02-2013	da Silva et al.	
	5	2001/0003443 A1	06-14-2001	VELAZQUEZ et al.	
	6	2002/0097700 A1	07-25-2002	Alastalo et al.	
	7	2004/0014429 A1	01-22-2004	Guo	

NON PATENT LITERATURE DOCUMENTS			
Examiner Initials	Cite No.	Include name of the author (in CAPITAL LETTERS), title of the article (when appropriate), title of the item (book, magazine, journal, serial, symposium, catalog, etc.), date, page(s), volume-issue number(s), publisher, city and/or country where published.	T <sup>1</sup>
	8	Decision to Institute; CISCO SYSTEMS, INC. v. XR COMMUNICATIONS LLC; Case No. IPR2018-00764; Paper 10; 39 pages.	no date
<del>NO DATES</del>	<del>9</del>	<del>Decision Institution of IPR; RUCKUS WIRELESS, INC. et al. v. XR COMMUNICATIONS LLC; Case No. IPR2018-01018; Paper 12; 39 pages.</del>	
	<del>10</del>	<del>Decision to Institute; RUCKUS WIRELESS, INC. et al. v. XR COMMUNICATIONS LLC; Case No. IPR2018-01017; 41 pages.</del>	
	<del>11</del>	<del>Decision to Institute, ARUBA NETWORKS, INC. v. XR COMMUNICATIONS, LLC, Case No. IPR2018-00725, U.S. Patent No. 7,062,296, 31 pages.</del>	
	<del>12</del>	<del>Decision Instituting IPR; ARUBA NETWORKS, INC. v. XR COMMUNICATIONS, LLC, Case No. IPR2018-00726, Paper 15, pages 33.</del>	
	<del>13</del>	<del>Decision Institution of IPR; CISCO SYSTEMS, INC. v. XR COMMUNICATIONS LLC; Case No. IPR2018-00763; Paper 9; 35 pages.</del>	
	<del>14</del>	<del>Decision to Institute IPR; CISCO SYSTEMS, INC. v. XR COMMUNICATIONS LLC; Case No. IPR2018-00762; Paper 10; 53 pages.</del>	
	<del>15</del>	<del>Decision Denying Institution; RUCKUS WIRELESS, INC. et al. v. XR COMMUNICATIONS LLC; Case No. IPR2018-01016; Paper 17, 22 pages.</del>	
	<del>16</del>	<del>Decision Denying Institution, ARUBA NETWORKS, INC. v. XR COMMUNICATIONS, LLC, Case No. IPR2018-00701, U.S. Patent No. 6,611,231, Paper 10; 16 pages.</del>	
	<del>17</del>	<del>Patent Owner's Preliminary Response; RUCKUS WIRELESS, INC. et al. v. XR COMMUNICATIONS LLC; Case No. IPR2018-01016; 31 pages.</del>	
	<del>18</del>	<del>Patent Owner's Preliminary Response; RUCKUS WIRELESS, INC. et al. v. XR COMMUNICATIONS LLC; Case No. IPR2018-01016; 61 pages.</del>	
	<del>19</del>	<del>Patent Owner's Preliminary Response; ARUBA NETWORKS, INC. v. XR COMMUNICATIONS, LLC, Case No. IPR2018-00726; 33 pages.</del>	

Examiner Signature /GINA M MCKIE/	Date Considered 06/11/2020
<p><b>*Examiner:</b> Initial if reference considered, whether or not citation is in conformance with MPEP 609. Draw line through citation if not in conformance and not considered. Include copy of this form with next communication to applicant.</p>	

T<sup>1</sup> - Place a check mark in this area when an English language Translation is attached.

ALL REFERENCES CONSIDERED EXCEPT WHERE LINED THROUGH. /G.M.M/

PTO/SB/08 Equivalent

<b>INFORMATION DISCLOSURE STATEMENT BY APPLICANT</b>	Application No.	15/495,539
	Filing Date	April 24, 2017
	First Named Inventor	Marcus Da Silva
	Art Unit	2631
<i>(Multiple sheets used when necessary)</i>	Examiner	McKie, Gina M.
SHEET 2 OF 2	Attorney Docket No.	1640-001.203

<b>NON PATENT LITERATURE DOCUMENTS</b>			
Examiner Initials	Cite No.	Include name of the author (in CAPITAL LETTERS), title of the article (when appropriate), title of the item (book, magazine, journal, serial, symposium, catalog, etc.), date, page(s), volume-issue number(s), publisher, city and/or country where published.	T <sup>1</sup>
	<del>20</del>	<del>Petitioner's Reply to Patent Owner's Preliminary Response; ARUBA NETWORKS, INC. v. XR COMMUNICATIONS, LLC, Case No. IPR2018-00726; 5 pages.</del>	<del>no date</del>
	<del>21</del>	<del>Patent Owner's Surr-reply to Petitioner's Reply to Patent Owner's Preliminary Response; ARUBA NETWORKS, INC. v. XR COMMUNICATIONS, LLC, Case No. IPR2018-00726; 6 pages.</del>	
	<del>22</del>	<del>Patent Owner's Preliminary Response; RUCKUS WIRELESS, INC. et al. v. XR COMMUNICATIONS LLC; Case No. IPR2018-01017; 61 pages.</del>	
	<del>23</del>	<del>Patent Owner's Preliminary Response; CISCO SYSTEMS, INC. v. XR COMMUNICATIONS LLC; Case No. IPR2018-00763; 40 pages.</del>	
	<del>24</del>	<del>Final Written Decision; ARUBA NETWORKS, INC. v. XR COMMUNICATIONS, LLC; Case No. IPR2018-00725; Paper 42; 57 pages.</del>	
	<del>25</del>	<del>Final Written Decision; CISCO SYSTEMS, INC. v. XR COMMUNICATIONS, LLC; Case No. IPR2018-00762; Paper 43; 28 pages.</del>	
	<del>26</del>	<del>Final Written Decision; CISCO SYSTEMS, INC. v. XR COMMUNICATIONS, LLC; Case No. IPR2018-00764; Paper 46; 86 pages.</del>	
	<b>27</b>	Bellafiore et al., "Smart antenna system analysis, integration and performance for mobile ad-hoc networks (MANETs)," in IEEE Transactions on Antennas and Propagation, vol. 50, no. 5, pp. 571-581, May 2002 (Year: 2002)	
	<b>28</b>	Lal et al., "A novel MAC layer protocol for space division multiple access in wireless ad hoc networks," Proceedings. Eleventh International Conference on Computer Communications and Networks, Miami, FL, USA, 2002, pp. 614-619 (Year: 2002)	

Examiner Signature /GINA M MCKIE/	Date Considered 06/11/2020
*Examiner: Initial if reference considered, whether or not citation is in conformance with MPEP 609. Draw line through citation if not in conformance and not considered. Include copy of this form with next communication to applicant.	

T<sup>1</sup> - Place a check mark in this area when an English language Translation is attached.

ALL REFERENCES CONSIDERED EXCEPT WHERE LINED THROUGH. /G.M.M/

<b>INFORMATION DISCLOSURE STATEMENT BY APPLICANT</b>	Application No.	15/495,539	
	Filing Date	April 24, 2017	
	First Named Inventor	Marcus Da Silva	
	Art Unit	2631	
<i>(Multiple sheets used when necessary)</i>		Examiner	McKie, Gina M.
SHEET 1 OF 2		Attorney Docket No.	1640-001.203

U.S. PATENT DOCUMENTS					
Examiner Initials	Cite No.	Document Number <i>Number - Kind Code (if known)</i> Example: 1,234,567 B1	Publication Date MM-DD-YYYY	Name of Patentee or Applicant	Pages, Columns, Lines Where Relevant Passages or Relevant Figures Appear
	1	5,933,421 A	08-03-1999	Alamouti et al.	
	2	6,414,986 B1	07-02-2002	Usui	
	3	6,982,968 B1	01-03-2006	Barratt et al.	
	4	8,412,106 B2	04-02-2013	da Silva et al.	
	5	2001/0003443 A1	06-14-2001	VELAZQUEZ et al.	
	6	2002/0097700 A1	07-25-2002	Alastalo et al.	
	7	2004/0014429 A1	01-22-2004	Guo	

NON PATENT LITERATURE DOCUMENTS			
Examiner Initials	Cite No.	Include name of the author (in CAPITAL LETTERS), title of the article (when appropriate), title of the item (book, magazine, journal, serial, symposium, catalog, etc.), date, page(s), volume-issue number(s), publisher, city and/or country where published.	T <sup>1</sup>
	8	Decision to Institute; CISCO SYSTEMS, INC. v. XR COMMUNICATIONS LLC; Case No. IPR2018-00764; Paper 10; 39 pages.	
	9	Decision Institution of IPR; RUCKUS WIRELESS, INC. et al. v. XR COMMUNICATIONS LLC; Case No. IPR2018-01018; Paper 12; 39 pages.	
	10	Decision to Institute; RUCKUS WIRELESS, INC. et al. v. XR COMMUNICATIONS LLC; Case No. IPR2018-01017; 41 pages.	
	11	Decision to Institute, ARUBA NETWORKS, INC. v. XR COMMUNICATIONS, LLC, Case No. IPR2018-00725, U.S. Patent No. 7,062,296, 31 pages.	
	12	Decision Instituting IPR; ARUBA NETWORKS, INC. v. XR COMMUNICATIONS, LLC, Case No. IPR2018-00726; Paper 15; pages 33.	
	13	Decision Institution of IPR; CISCO SYSTEMS, INC. v. XR COMMUNICATIONS LLC; Case No. IPR2018-00763; Paper 9; 35 pages.	
	14	Decision to Institute IPR; CISCO SYSTEMS, INC. v. XR COMMUNICATIONS LLC; Case No. IPR2018-00762; Paper 10; 53 pages.	
	15	Decision Denying Institution; RUCKUS WIRELESS, INC. et al. v. XR COMMUNICATIONS LLC; Case No. IPR2018-01016; Paper 17; 22 pages.	
	16	Decision Denying Institution, ARUBA NETWORKS, INC. v. XR COMMUNICATIONS, LLC, Case No. IPR2018-00701, U.S. Patent No. 6,611,231, Paper 10; 16 pages.	
	17	Patent Owner's Preliminary Response; RUCKUS WIRELESS, INC. et al. v. XR COMMUNICATIONS LLC; Case No. IPR2018-01016; 31 pages.	
	18	Patent Owner's Preliminary Response; RUCKUS WIRELESS, INC. et al. v. XR COMMUNICATIONS LLC; Case No. IPR2018-01018; 61 pages.	
	19	Patent Owner's Preliminary Response; ARUBA NETWORKS, INC. v. XR COMMUNICATIONS, LLC, Case No. IPR2018-00726; 33 pages.	

Examiner Signature	Date Considered
<p><b>*Examiner:</b> Initial if reference considered, whether or not citation is in conformance with MPEP 609. Draw line through citation if not in conformance and not considered. Include copy of this form with next communication to applicant.</p>	

T<sup>1</sup> - Place a check mark in this area when an English language Translation is attached.



<b>INFORMATION DISCLOSURE STATEMENT BY APPLICANT</b>	Application No.	15/495,539
	Filing Date	April 24, 2017
	First Named Inventor	Marcus Da Silva
	Art Unit	2631
<i>(Multiple sheets used when necessary)</i>	Examiner	McKie, Gina M.
SHEET 2 OF 2	Attorney Docket No.	1640-001.203

<b>NON PATENT LITERATURE DOCUMENTS</b>			
Examiner Initials	Cite No.	Include name of the author (in CAPITAL LETTERS), title of the article (when appropriate), title of the item (book, magazine, journal, serial, symposium, catalog, etc.), date, page(s), volume-issue number(s), publisher, city and/or country where published.	T <sup>1</sup>
	<b>20</b>	Petitioner's Reply to Patent Owner's Preliminary Response; ARUBA NETWORKS, INC. v. XR COMMUNICATIONS, LLC, Case No. IPR2018-00726; 5 pages.	
	<b>21</b>	Patent Owner's Surr-reply to Petitioner's Reply to Patent Owner's Preliminary Response; ARUBA NETWORKS, INC. v. XR COMMUNICATIONS, LLC, Case No. IPR2018-00726; 6 pages.	
	<b>22</b>	Patent Owner's Preliminary Response; RUCKUS WIRELESS, INC. et al. v. XR COMMUNICATIONS LLC; Case No. IPR2018-01017; 61 pages.	
	<b>23</b>	Patent Owner's Preliminary Response; CISCO SYSTEMS, INC. v. XR COMMUNICATIONS LLC; Case No. IPR2018-00763; 40 pages.	
	<b>24</b>	Final Written Decision; ARUBA NETWORKS, INC. v. XR COMMUNICATIONS, LLC; Case No. IPR2018-00725; Paper 42; 57 pages.	
	<b>25</b>	Final Written Decision; CISCO SYSTEMS, INC. v. XR COMMUNICATIONS, LLC; Case No. IPR2018-00762; Paper 43; 28 pages.	
	<b>26</b>	Final Written Decision; CISCO SYSTEMS, INC. v. XR COMMUNICATIONS, LLC; Case No. IPR2018-00764; Paper 46; 86 pages.	
	<b>27</b>	Bellafore et al., "Smart antenna system analysis, integration and performance for mobile ad-hoc networks (MANETs)," in IEEE Transactions on Antennas and Propagation, vol. 50, no. 5, pp. 571-581, May 2002 (Year: 2002)	
	<b>28</b>	Lal et al., "A novel MAC layer protocol for space division multiple access in wireless ad hoc networks," Proceedings. Eleventh International Conference on Computer Communications and Networks, Miami, FL, USA, 2002, pp. 614-619 (Year: 2002)	

Examiner Signature	Date Considered
<p><b>*Examiner:</b> Initial if reference considered, whether or not citation is in conformance with MPEP 609. Draw line through citation if not in conformance and not considered. Include copy of this form with next communication to applicant.</p>	

T<sup>1</sup> - Place a check mark in this area when an English language Translation is attached.

**PART B - FEE(S) TRANSMITTAL**

Complete and send this form, together with applicable fee(s), by mail or fax, or via EFS-Web.

By mail, send to: Mail Stop ISSUE FEE  
 Commissioner for Patents  
 P.O. Box 1450  
 Alexandria, Virginia 22313-1450

By fax, send to: (571)-273-2885

**INSTRUCTIONS:** This form should be used for transmitting the ISSUE FEE and PUBLICATION FEE (if required). Blocks 1 through 5 should be completed where appropriate. All further correspondence including the Patent, advance orders and notification of maintenance fees will be mailed to the current correspondence address as indicated unless corrected below or directed otherwise in Block 1, by (a) specifying a new correspondence address; and/or (b) indicating a separate "FEE ADDRESS" for maintenance fee notifications.

CURRENT CORRESPONDENCE ADDRESS (Note: Use Block 1 for any change of address)

22145 7590 03/05/2020  
 KLEIN, O'NEILL & SINGH, LLP  
 16755 VON KARMAN AVENUE  
 SUITE 275  
 IRVINE, CA 92606

Note: A certificate of mailing can only be used for domestic mailings of the Fee(s) Transmittal. This certificate cannot be used for any other accompanying papers. Each additional paper, such as an assignment or formal drawing, must have its own certificate of mailing or transmission.

**Certificate of Mailing or Transmission**

I hereby certify that this Fee(s) Transmittal is being deposited with the United States Postal Service with sufficient postage for first class mail in an envelope addressed to the Mail Stop ISSUE FEE address above, or being transmitted to the USPTO via EFS-Web or by facsimile to (571) 273-2885, on the date below.

(Typed or printed name)
(Signature)
(Date)

APPLICATION NO.	FILING DATE	FIRST NAMED INVENTOR	ATTORNEY DOCKET NO.	CONFIRMATION NO.
15/495,539	04/24/2017	Marcus Da Silva	1640-001.203	1050

TITLE OF INVENTION: DIRECTED WIRELESS COMMUNICATION

APPLN. TYPE	ENTITY STATUS	ISSUE FEE DUE	PUBLICATION FEE DUE	PREV. PAID ISSUE FEE	TOTAL FEE(S) DUE	DATE DUE
nonprovisional	SMALL	\$500	\$0.00	\$0.00	\$500	06/05/2020

EXAMINER	ART UNIT	CLASS-SUBCLASS
MCKIE, GINA M	2631	375-365000

1. Change of correspondence address or indication of "Fee Address" (37 CFR 1.363).

- Change of correspondence address (or Change of Correspondence Address form PTO/SB/122) attached.
- "Fee Address" indication (or "Fee Address" indication form PTO/SB/47; Rev 03-09 or more recent) attached. **Use of a Customer Number is required.**

2. For printing on the patent front page, list

- (1) The names of up to 3 registered patent attorneys or agents OR, alternatively,  
 (2) The name of a single firm (having as a member a registered attorney or agent) and the names of up to 2 registered patent attorneys or agents. If no name is listed, no name will be printed.

1. Klein, O'Neill & Singh, LLP

2. \_\_\_\_\_

3. \_\_\_\_\_

3. ASSIGNEE NAME AND RESIDENCE DATA TO BE PRINTED ON THE PATENT (print or type)

PLEASE NOTE: Unless an assignee is identified below, no assignee data will appear on the patent. If an assignee is identified below, the document must have been previously recorded, or filed for recordation, as set forth in 37 CFR 3.11 and 37 CFR 3.81(a). Completion of this form is NOT a substitute for filing an assignment.

(A) NAME OF ASSIGNEE

(B) RESIDENCE: (CITY and STATE OR COUNTRY)

Please check the appropriate assignee category or categories (will not be printed on the patent):  Individual  Corporation or other private group entity  Government

4a. Fees submitted:  Issue Fee  Publication Fee (if required)  Advance Order - # of Copies \_\_\_\_\_

4b. Method of Payment: (Please first reapply any previously paid fee shown above)

Electronic Payment via EFS-Web  Enclosed check  Non-electronic payment by credit card (Attach form PTO-2038)

The Director is hereby authorized to charge the required fee(s), any deficiency, or credit any overpayment to Deposit Account No. 11-1159

5. Change in Entity Status (from status indicated above)

- Applicant certifying micro entity status. See 37 CFR 1.29
- Applicant asserting small entity status. See 37 CFR 1.27
- Applicant changing to regular undiscounted fee status.

**NOTE:** Absent a valid certification of Micro Entity Status (see forms PTO/SB/15A and 15B), issue fee payment in the micro entity amount will not be accepted at the risk of application abandonment.  
**NOTE:** If the application was previously under micro entity status, checking this box will be taken to be a notification of loss of entitlement to micro entity status.  
**NOTE:** Checking this box will be taken to be a notification of loss of entitlement to small or micro entity status, as applicable.

NOTE: This form must be signed in accordance with 37 CFR 1.31 and 1.33. See 37 CFR 1.4 for signature requirements and certifications.

Authorized Signature /Glen L. Nuttall/

Date June 5, 2020

Typed or printed name Glen L. Nuttall

Registration No. 46,188

IN THE UNITED STATES PATENT AND TRADEMARK OFFICE

Applicants: Marcus Da Silva et al.  
Title: DIRECTED WIRELESS COMMUNICATION  
Serial No.: 15/495,539 Filed: April 24, 2017  
Examiner: McKie, Gina M. Group Art Unit: 2631  
Attorney Docket No.: 1640-001.203 Confirmation No.: 1050

---

**CERTIFICATE OF EFS-WEB TRANSMISSION  
UNDER 37 CFR § 1.8**

I hereby certify that the enclosed IDS Transmittal (3 pages); Information Disclosure Statement by Applicant (2 pages); Issue Fee Transmittal Form PTOL-85 (1 page); and Payment by Credit Card are being transmitted to the United States Patent and Trademark Office **from the Pacific Time Zone** via EFS-Web on June 5, 2020.

Date: June 5, 2020

/Glen L. Nuttall/

Glen L. Nuttall

Mailing Address:

**KLEIN, O'NEILL & SINGH, LLP (Customer No.: 22145)**  
16755 Von Karman Avenue, Suite 275  
Irvine, California 92606  
Tel: 949-955-1920  
Fax: 949-955-1921

## Electronic Patent Application Fee Transmittal

<b>Application Number:</b>	15495539				
<b>Filing Date:</b>	24-Apr-2017				
<b>Title of Invention:</b>	DIRECTED WIRELESS COMMUNICATION				
<b>First Named Inventor/Applicant Name:</b>	Marcus Da Silva				
<b>Filer:</b>	Glen L. Nuttall/Cindy Chen				
<b>Attorney Docket Number:</b>	1640-001.203				
Filed as Small Entity					
<b>Filing Fees for Utility under 35 USC 111(a)</b>					
<b>Description</b>	<b>Fee Code</b>	<b>Quantity</b>	<b>Amount</b>	<b>Sub-Total in USD(\$)</b>	
<b>Basic Filing:</b>					
<b>Pages:</b>					
<b>Claims:</b>					
<b>Miscellaneous-Filing:</b>					
<b>Petition:</b>					
<b>Patent-Appeals-and-Interference:</b>					
<b>Post-Allowance-and-Post-Issuance:</b>					
UTILITY APPL ISSUE FEE	2501	1	500	500	

Description	Fee Code	Quantity	Amount	Sub-Total in USD(\$)
<b>Extension-of-Time:</b>				
<b>Miscellaneous:</b>				
SUBMISSION- INFORMATION DISCLOSURE STMT	2806	1	120	120
<b>Total in USD (\$)</b>				<b>620</b>

## Electronic Acknowledgement Receipt

<b>EFS ID:</b>	39646636
<b>Application Number:</b>	15495539
<b>International Application Number:</b>	
<b>Confirmation Number:</b>	1050
<b>Title of Invention:</b>	DIRECTED WIRELESS COMMUNICATION
<b>First Named Inventor/Applicant Name:</b>	Marcus Da Silva
<b>Customer Number:</b>	22145
<b>Filer:</b>	Glen L. Nuttall/Cindy Chen
<b>Filer Authorized By:</b>	Glen L. Nuttall
<b>Attorney Docket Number:</b>	1640-001.203
<b>Receipt Date:</b>	05-JUN-2020
<b>Filing Date:</b>	24-APR-2017
<b>Time Stamp:</b>	22:41:36
<b>Application Type:</b>	Utility under 35 USC 111(a)

### Payment information:

Submitted with Payment	yes
Payment Type	CARD
Payment was successfully received in RAM	\$620
RAM confirmation Number	E202065M43578271
Deposit Account	111159
Authorized User	Cindy Chen

The Director of the USPTO is hereby authorized to charge indicated fees and credit any overpayment as follows:

37 CFR 1.17 (Patent application and reexamination processing fees)

<b>File Listing:</b>						
<b>Document Number</b>	<b>Document Description</b>	<b>File Name</b>	<b>File Size(Bytes)/ Message Digest</b>	<b>Multi Part /.zip</b>	<b>Pages (if appl.)</b>	
1		1640-001-203--IDS- IFPaymentAsFiled06052020.pdf	338749  243b3137e6252a48ee6c38362538f29ecf1b545a	yes	7	
<b>Multipart Description/PDF files in .zip description</b>						
		<b>Document Description</b>	<b>Start</b>	<b>End</b>		
		Transmittal Letter	1	3		
		Information Disclosure Statement (IDS) Form (SB08)	4	5		
		Issue Fee Payment (PTO-85B)	6	6		
		Miscellaneous Incoming Letter	7	7		
<b>Warnings:</b>						
<b>Information:</b>						
2	Non Patent Literature	NPL--IPR2018-00764-P10.pdf	461195  b67fa0330a07af4d6ffe2284bc6bc39d4d0f304	no	39	
<b>Warnings:</b>						
<b>Information:</b>						
3	Non Patent Literature	NPL--IPR2018-01018-P12.pdf	1156697  d924c6de6f428e5bb232ae7225aabe03e764f38e	no	39	
<b>Warnings:</b>						
<b>Information:</b>						
4	Non Patent Literature	NPL--IPR2018-01017-P12.pdf	657035  7f4de059277e9c29c41703a0b5620882c1622490	no	41	
<b>Warnings:</b>						
<b>Information:</b>						

5	Non Patent Literature	NPL--IPR2018-00725-P14-Dectolnstitute.pdf	414787	no	31
			ea61ff6af106ebf4d08480132687e0ac43cf8a85		
<b>Warnings:</b>					
<b>Information:</b>					
6	Non Patent Literature	NPL--IPR2018-00726-P15.pdf	508387	no	33
			68a9484ccfab0dfcbb4f557aa743f3d78651f1f9		
<b>Warnings:</b>					
<b>Information:</b>					
7	Non Patent Literature	NPL--IPR2018-01016-P17.pdf	311613	no	22
			d41bf0626ff50ee03730ba481b379702d645f38b		
<b>Warnings:</b>					
<b>Information:</b>					
8	Non Patent Literature	NPL--IPR2018-00701-P10.pdf	265441	no	16
			002dc5ed79af40f555bb22a9d1ed6d50aec6d8ff		
<b>Warnings:</b>					
<b>Information:</b>					
9	Non Patent Literature	NPL--IPR2018-01016-P13-POsPrelimResp.pdf	1065499	no	34
			6999a859b6a79ec63536f17d3aa0c4423fc7ce2b		
<b>Warnings:</b>					
<b>Information:</b>					
10	Non Patent Literature	NPL--IPR2018-01018-P9-POsPrelimResp.pdf	1111166	no	61
			45a577d3cc9d3ce2c2e73cb2b7c3c5cf9084c18		
<b>Warnings:</b>					
<b>Information:</b>					
11	Non Patent Literature	NPL--IPR2018-00726-P8-POsPrelimResp.pdf	788958	no	33
			111f8530c4b724699e7265f3fad0719e262535fc		
<b>Warnings:</b>					
<b>Information:</b>					



12	Non Patent Literature	NPL--IPR2018-00726-P12-PetsReplytoPOsPrelimResp.pdf	758231	no	5
			b67f2f68d972cbf44f5cbe05ec40393d3831e568		
<b>Warnings:</b>					
<b>Information:</b>					
13	Non Patent Literature	NPL--IPR2018-00726-P13-POsSurReplytoPetsReplytoPOsPrelimResp.pdf	127705	no	6
			7243f20f0845a20ac781e5278350a697528de4fb		
<b>Warnings:</b>					
<b>Information:</b>					
14	Non Patent Literature	NPL--IPR2018-01017-P9-POsPrelimResp.pdf	1163437	no	61
			8a9f66408a6f2125ed9bc081d3e2ff6e80deb4c		
<b>Warnings:</b>					
<b>Information:</b>					
15	Non Patent Literature	NPL--IPR2018-00763-P8-POsPrelimResp.pdf	546562	no	40
			c37796c7c3a91322b7091586184218a2fc306222		
<b>Warnings:</b>					
<b>Information:</b>					
16	Non Patent Literature	NPL--IPR2018-00725-P42.pdf	614857	no	57
			5233175e7340dc79aad6a7a7eb85b71d12119cb9		
<b>Warnings:</b>					
<b>Information:</b>					
17	Non Patent Literature	NPL--IPR2018-00762-P43.pdf	550824	no	28
			8d56d571dffa42eda9c4a4857ca3dc95b04277ea		
<b>Warnings:</b>					
<b>Information:</b>					
18	Non Patent Literature	NPL--IPR2018-00764-P46.pdf	915731	no	86
			239b9a08aa0778061d5774e384e7e480a036368c		
<b>Warnings:</b>					
<b>Information:</b>					

19	Non Patent Literature	NPL--IPR2018-00763-P9.pdf	674692	no	35
			63436f0e3c0a746bba1e6a62f9d4c28e3a35fa75		
<b>Warnings:</b>					
<b>Information:</b>					
20	Non Patent Literature	NPL--IPR2018-00762-P10.pdf	957122	no	53
			9452f3e8e52730879fe92135c11ea8f056517f44		
<b>Warnings:</b>					
<b>Information:</b>					
21	Non Patent Literature	NPL--BELLAFIGLIO- SmartAntennaSystemAnalysis- May2002.pdf	12057242	no	11
			f22f17b7e5010ccc4db1cea49f050612812bd367		
<b>Warnings:</b>					
<b>Information:</b>					
22	Non Patent Literature	NPL--LAL- NovelMACLayerProtocol-2002. pdf	4130077	no	14
			4a36dd7f01110835b86fa47ed9623adad2bb9e96		
<b>Warnings:</b>					
<b>Information:</b>					
23	Fee Worksheet (SB06)	fee-info.pdf	32218	no	2
			7e6843abc4fad74309cf21c4574f34cecf6a6a25d		
<b>Warnings:</b>					
<b>Information:</b>					
<b>Total Files Size (in bytes):</b>				29608225	

**This Acknowledgement Receipt evidences receipt on the noted date by the USPTO of the indicated documents, characterized by the applicant, and including page counts, where applicable. It serves as evidence of receipt similar to a Post Card, as described in MPEP 503.**

**New Applications Under 35 U.S.C. 111**

**If a new application is being filed and the application includes the necessary components for a filing date (see 37 CFR 1.53(b)-(d) and MPEP 506), a Filing Receipt (37 CFR 1.54) will be issued in due course and the date shown on this Acknowledgement Receipt will establish the filing date of the application.**

**National Stage of an International Application under 35 U.S.C. 371**

**If a timely submission to enter the national stage of an international application is compliant with the conditions of 35 U.S.C. 371 and other applicable requirements a Form PCT/DO/EO/903 indicating acceptance of the application as a national stage submission under 35 U.S.C. 371 will be issued in addition to the Filing Receipt, in due course.**

**New International Application Filed with the USPTO as a Receiving Office**

**If a new international application is being filed and the international application includes the necessary components for an international filing date (see PCT Article 11 and MPEP 1810), a Notification of the International Application Number and of the International Filing Date (Form PCT/RO/105) will be issued in due course, subject to prescriptions concerning national security, and the date shown on this Acknowledgement Receipt will establish the international filing date of the application.**

# Information Disclosure Statement Transmittal

Docket Number

1640-001.203

Address To  
Commissioner for Patents  
P.O. Box 1450  
Alexandria, Virginia 22313-1450

## In Re Application Of:

Da Silva et al.

Application No. 15/495,539

Filing Date April 24, 2017

Examiner McKie, Gina M.

Art Unit 2631

## Title of Invention

DIRECTED WIRELESS COMMUNICATION

## BASIS FOR FILING (Select 1, 2 or 3 below.)

### 37 CFR 1.97(b)

- 1)  The Information Disclosure Statement submitted herewith is being filed within three months of the filing of a national application other than a continued prosecution application under 37 CFR 1.53 (d); within three months of the date of entry of the national stage as set forth in 37 CFR 1.491 in an international application; before the mailing of a first Office Action on the merits, or before the mailing of a first Office Action after the filing of a request for continued examination under 37 CFR 1.114.

### 37 CFR 1.97(c)

- 2)  The Information Disclosure Statement submitted herewith is being filed after the period specified in 37 CFR 1.97(b), but before the mailing date of a Final Action under 37 CFR 1.113, a Notice of Allowance under 37 CFR 1.311, or an Action that otherwise closes prosecution in the application, and is accompanied by one of:

a)  the statement specified in 37 CFR 1.97(e);

OR

b)  the fee set forth in 37 CFR 1.17(p).

### 37 CFR 1.97(d)

- 3)  The Information Disclosure Statement submitted herewith is being filed after the period specified in 37 CFR 1.97(c), and on or before payment of the issue fee, and is accompanied by the Statement as specified in 37 CFR 1.97(e) and the fee set forth in 37 CFR 1.17(p).

# Information Disclosure Statement Transmittal

Docket Number

1640-001.203

## STATEMENT UNDER 37 CFR 1.97(e) ACCOMPANYING INFORMATION DISCLOSURE STATEMENT

The Information Disclosure Statement submitted herewith is submitted under one of the following conditions, which satisfies the requirement under 37 CFR 1.97(e). (Select 4 or 5 below if applicable.)

- 4)  That each item of information contained in the Information Disclosure Statement was first cited in any communication from a foreign patent office in a counterpart foreign application not more than three months prior to the filing of the Information Disclosure Statement; or
- 5)  That no item of information contained in the Information Disclosure Statement was cited in a communication from a foreign patent office in a counterpart foreign application, and, to the knowledge of the person signing the certification after making reasonable inquiry, no item of information contained in the Information Disclosure Statement was known to any individual designated in 37 CFR 1.56(c) more than three months prior to the filing of the Information Disclosure Statement.

## Remarks (Enter Remarks Below or Attach Document Containing Remarks)

## Fee set forth in 37 CFR 1.17(p):

- No additional fee is required.
- A check in the amount of \_\_\_\_\_ is attached.
- The Director is hereby authorized to charge and credit Deposit Account No. 11-1159 as described below.
- Charge the amount of \_\_\_\_\_
- Credit any overpayment.
- Charge any additional fee required.
- Payment by credit card. Form PTO-2038 is attached.

**WARNING: Information on this form may become public. Credit card information should not be included on this form. Provide credit card information and authorization on PTO-2038.**

# Information Disclosure Statement Transmittal

Docket Number

1640-001.203

## Correspondence Address

Customer Number 22145

-OR-

Name

Address

City

State

Country

Postal Code

Phone Number

E-mail Address

### Certificate of Mailing by Express Mail

I hereby certify that this Transmittal Letter, accompanying documents and fee (if appropriate) are being deposited with the United States Postal Service "Express Mail Post Office to Addressee" service under 37 CFR 1.10 in an envelope addressed to Commissioner for Patents, P.O. Box 1450, Alexandria, Virginia 22313-1450 on the date indicated below:

\_\_\_\_\_  
(Date of Mailing)

\_\_\_\_\_  
(Typed or Printed Name of Person Mailing Correspondence)

\_\_\_\_\_  
(Signature of Person Mailing Correspondence)

\_\_\_\_\_  
("Express Mail" Mailing Label Number)

### Certificate of Mailing by First Class Mail

I hereby certify that this Transmittal Letter, accompanying documents and fee (if appropriate) are being deposited with the United States Postal Service with sufficient postage as first class mail in an envelope addressed to Commissioner for Patents, P.O. Box 1450, Alexandria, Virginia 22313-1450 on the date indicated below:

\_\_\_\_\_  
(Date of Mailing)

\_\_\_\_\_  
(Name of Person Mailing Correspondence)

\_\_\_\_\_  
(Signature of Person Mailing Correspondence)

### Certificate of Transmission

I hereby certify that this Transmittal Letter, accompanying documents and fee authorization (if appropriate) is being facsimile transmitted to the United States Patent and Trademark Office on the date indicated below:

\_\_\_\_\_  
(Date of Transmission)

\_\_\_\_\_  
(Name of Person Transmitting Correspondence)

\_\_\_\_\_  
(Signature of Person Transmitting Correspondence)

### Signature Instructions


Select the name of the person who will electronically sign the Transmittal Letter from the drop-down box below.

If a practitioner is not present in the drop-down list, you must close this form and select 'Add Practitioner...' in the Form Manager's Utility menu.

Verify that the signatory information is correct and press the 'eSign' button to electronically sign the submission. If you prefer to sign the form manually, simply do not click the 'eSign' button; just print and manually sign.

Signatory Drop-Down Box

Glen L. Nuttall

Name	Glen L. Nuttall	Registration Number	46,188
Signatory Capacity	Attorney for Applicant	E-mail Address	GlenNuttall@koslaw.com
	/Glen L. Nuttall/	Date Signed	6/5/2020



UNITED STATES PATENT AND TRADEMARK OFFICE

UNITED STATES DEPARTMENT OF COMMERCE
United States Patent and Trademark Office
Address: COMMISSIONER FOR PATENTS
P.O. Box 1450
Alexandria, Virginia 22313-1450
www.uspto.gov

NOTICE OF ALLOWANCE AND FEE(S) DUE

22145 7590 03/05/2020
KLEIN, O'NEILL & SINGH, LLP
16755 VON KARMAN AVENUE
SUITE 275
IRVINE, CA 92606

EXAMINER

MCKIE, GINA M

ART UNIT PAPER NUMBER

2631

DATE MAILED: 03/05/2020

Table with 5 columns: APPLICATION NO., FILING DATE, FIRST NAMED INVENTOR, ATTORNEY DOCKET NO., CONFIRMATION NO.
15/495,539 04/24/2017 Marcus Da Silva 1640-001.203 1050

TITLE OF INVENTION: DIRECTED WIRELESS COMMUNICATION

Table with 7 columns: APPLN. TYPE, ENTITY STATUS, ISSUE FEE DUE, PUBLICATION FEE DUE, PREV. PAID ISSUE FEE, TOTAL FEE(S) DUE, DATE DUE
nonprovisional SMALL \$500 \$0.00 \$0.00 \$500 06/05/2020

THE APPLICATION IDENTIFIED ABOVE HAS BEEN EXAMINED AND IS ALLOWED FOR ISSUANCE AS A PATENT. PROSECUTION ON THE MERITS IS CLOSED. THIS NOTICE OF ALLOWANCE IS NOT A GRANT OF PATENT RIGHTS. THIS APPLICATION IS SUBJECT TO WITHDRAWAL FROM ISSUE AT THE INITIATIVE OF THE OFFICE OR UPON PETITION BY THE APPLICANT. SEE 37 CFR 1.313 AND MPEP 1308.

THE ISSUE FEE AND PUBLICATION FEE (IF REQUIRED) MUST BE PAID WITHIN THREE MONTHS FROM THE MAILING DATE OF THIS NOTICE OR THIS APPLICATION SHALL BE REGARDED AS ABANDONED. THIS STATUTORY PERIOD CANNOT BE EXTENDED. SEE 35 U.S.C. 151. THE ISSUE FEE DUE INDICATED ABOVE DOES NOT REFLECT A CREDIT FOR ANY PREVIOUSLY PAID ISSUE FEE IN THIS APPLICATION. IF AN ISSUE FEE HAS PREVIOUSLY BEEN PAID IN THIS APPLICATION (AS SHOWN ABOVE), THE RETURN OF PART B OF THIS FORM WILL BE CONSIDERED A REQUEST TO REAPPLY THE PREVIOUSLY PAID ISSUE FEE TOWARD THE ISSUE FEE NOW DUE.

HOW TO REPLY TO THIS NOTICE:

I. Review the ENTITY STATUS shown above. If the ENTITY STATUS is shown as SMALL or MICRO, verify whether entitlement to that entity status still applies.

If the ENTITY STATUS is the same as shown above, pay the TOTAL FEE(S) DUE shown above.

If the ENTITY STATUS is changed from that shown above, on PART B - FEE(S) TRANSMITTAL, complete section number 5 titled "Change in Entity Status (from status indicated above)".

For purposes of this notice, small entity fees are 1/2 the amount of undiscounted fees, and micro entity fees are 1/2 the amount of small entity fees.

II. PART B - FEE(S) TRANSMITTAL, or its equivalent, must be completed and returned to the United States Patent and Trademark Office (USPTO) with your ISSUE FEE and PUBLICATION FEE (if required). If you are charging the fee(s) to your deposit account, section "4b" of Part B - Fee(s) Transmittal should be completed and an extra copy of the form should be submitted. If an equivalent of Part B is filed, a request to reapply a previously paid issue fee must be clearly made, and delays in processing may occur due to the difficulty in recognizing the paper as an equivalent of Part B.

III. All communications regarding this application must give the application number. Please direct all communications prior to issuance to Mail Stop ISSUE FEE unless advised to the contrary.

IMPORTANT REMINDER: Maintenance fees are due in utility patents issuing on applications filed on or after Dec. 12, 1980. It is patentee's responsibility to ensure timely payment of maintenance fees when due. More information is available at www.uspto.gov/PatentMaintenanceFees.

**PART B - FEE(S) TRANSMITTAL**

Complete and send this form, together with applicable fee(s), by mail or fax, or via EFS-Web.

By mail, send to: Mail Stop ISSUE FEE  
 Commissioner for Patents  
 P.O. Box 1450  
 Alexandria, Virginia 22313-1450

By fax, send to: (571)-273-2885

**INSTRUCTIONS:** This form should be used for transmitting the ISSUE FEE and PUBLICATION FEE (if required). Blocks 1 through 5 should be completed where appropriate. All further correspondence including the Patent, advance orders and notification of maintenance fees will be mailed to the current correspondence address as indicated unless corrected below or directed otherwise in Block 1, by (a) specifying a new correspondence address; and/or (b) indicating a separate "FEE ADDRESS" for maintenance fee notifications.

CURRENT CORRESPONDENCE ADDRESS (Note: Use Block 1 for any change of address)

22145 7590 03/05/2020  
 KLEIN, O'NEILL & SINGH, LLP  
 16755 VON KARMAN AVENUE  
 SUITE 275  
 IRVINE, CA 92606

Note: A certificate of mailing can only be used for domestic mailings of the Fee(s) Transmittal. This certificate cannot be used for any other accompanying papers. Each additional paper, such as an assignment or formal drawing, must have its own certificate of mailing or transmission.

**Certificate of Mailing or Transmission**

I hereby certify that this Fee(s) Transmittal is being deposited with the United States Postal Service with sufficient postage for first class mail in an envelope addressed to the Mail Stop ISSUE FEE address above, or being transmitted to the USPTO via EFS-Web or by facsimile to (571) 273-2885, on the date below.

_____ (Typed or printed name)
_____ (Signature)
_____ (Date)

APPLICATION NO.	FILING DATE	FIRST NAMED INVENTOR	ATTORNEY DOCKET NO.	CONFIRMATION NO.
15/495,539	04/24/2017	Marcus Da Silva	1640-001.203	1050

TITLE OF INVENTION: DIRECTED WIRELESS COMMUNICATION

APPLN. TYPE	ENTITY STATUS	ISSUE FEE DUE	PUBLICATION FEE DUE	PREV. PAID ISSUE FEE	TOTAL FEE(S) DUE	DATE DUE
nonprovisional	SMALL	\$500	\$0.00	\$0.00	\$500	06/05/2020

EXAMINER	ART UNIT	CLASS-SUBCLASS
MCKIE, GINA M	2631	375-365000

<p>1. Change of correspondence address or indication of "Fee Address" (37 CFR 1.363).</p> <p><input type="checkbox"/> Change of correspondence address (or Change of Correspondence Address form PTO/SB/122) attached.</p> <p><input type="checkbox"/> "Fee Address" indication (or "Fee Address" Indication form PTO/SB/47; Rev 03-09 or more recent) attached. <b>Use of a Customer Number is required.</b></p>	<p>2. For printing on the patent front page, list</p> <p>(1) The names of up to 3 registered patent attorneys or agents OR, alternatively, 1 _____</p> <p>(2) The name of a single firm (having as a member a registered attorney or agent) and the names of up to 2 registered patent attorneys or agents. If no name is listed, no name will be printed. 2 _____</p> <p>3 _____</p>
---	---

3. ASSIGNEE NAME AND RESIDENCE DATA TO BE PRINTED ON THE PATENT (print or type)

PLEASE NOTE: Unless an assignee is identified below, no assignee data will appear on the patent. If an assignee is identified below, the document must have been previously recorded, or filed for recordation, as set forth in 37 CFR 3.11 and 37 CFR 3.81(a). Completion of this form is NOT a substitute for filing an assignment.

(A) NAME OF ASSIGNEE \_\_\_\_\_ (B) RESIDENCE: (CITY and STATE OR COUNTRY) \_\_\_\_\_

Please check the appropriate assignee category or categories (will not be printed on the patent):  Individual  Corporation or other private group entity  Government

4a. Fees submitted:  Issue Fee  Publication Fee (if required)  Advance Order - # of Copies \_\_\_\_\_

4b. Method of Payment: (Please first reapply any previously paid fee shown above)

Electronic Payment via EFS-Web  Enclosed check  Non-electronic payment by credit card (Attach form PTO-2038)

The Director is hereby authorized to charge the required fee(s), any deficiency, or credit any overpayment to Deposit Account No. \_\_\_\_\_

5. Change in Entity Status (from status indicated above)

Applicant certifying micro entity status. See 37 CFR 1.29

Applicant asserting small entity status. See 37 CFR 1.27

Applicant changing to regular undiscounted fee status.

**NOTE:** Absent a valid certification of Micro Entity Status (see forms PTO/SB/15A and 15B), issue fee payment in the micro entity amount will not be accepted at the risk of application abandonment.

**NOTE:** If the application was previously under micro entity status, checking this box will be taken to be a notification of loss of entitlement to micro entity status.

**NOTE:** Checking this box will be taken to be a notification of loss of entitlement to small or micro entity status, as applicable.

**NOTE:** This form must be signed in accordance with 37 CFR 1.31 and 1.33. See 37 CFR 1.4 for signature requirements and certifications.

Authorized Signature \_\_\_\_\_ Date \_\_\_\_\_

Typed or printed name \_\_\_\_\_ Registration No. \_\_\_\_\_





UNITED STATES PATENT AND TRADEMARK OFFICE

UNITED STATES DEPARTMENT OF COMMERCE
United States Patent and Trademark Office
Address: COMMISSIONER FOR PATENTS
P.O. Box 1450
Alexandria, Virginia 22313-1450
www.uspto.gov

Table with 5 columns: APPLICATION NO., FILING DATE, FIRST NAMED INVENTOR, ATTORNEY DOCKET NO., CONFIRMATION NO. Includes applicant information for KLEIN, O'NEILL & SINGH, LLP and examiner information for MCKIE, GINA M.

Determination of Patent Term Adjustment under 35 U.S.C. 154 (b)
(Applications filed on or after May 29, 2000)

The Office has discontinued providing a Patent Term Adjustment (PTA) calculation with the Notice of Allowance.

Section 1(h)(2) of the AIA Technical Corrections Act amended 35 U.S.C. 154(b)(3)(B)(i) to eliminate the requirement that the Office provide a patent term adjustment determination with the notice of allowance.

Any questions regarding the Patent Term Extension or Adjustment determination should be directed to the Office of Patent Legal Administration at (571)-272-7702.

## OMB Clearance and PRA Burden Statement for PTOL-85 Part B

The Paperwork Reduction Act (PRA) of 1995 requires Federal agencies to obtain Office of Management and Budget approval before requesting most types of information from the public. When OMB approves an agency request to collect information from the public, OMB (i) provides a valid OMB Control Number and expiration date for the agency to display on the instrument that will be used to collect the information and (ii) requires the agency to inform the public about the OMB Control Number's legal significance in accordance with 5 CFR 1320.5(b).

The information collected by PTOL-85 Part B is required by 37 CFR 1.311. The information is required to obtain or retain a benefit by the public which is to file (and by the USPTO to process) an application. Confidentiality is governed by 35 U.S.C. 122 and 37 CFR 1.14. This collection is estimated to take 30 minutes to complete, including gathering, preparing, and submitting the completed application form to the USPTO. Time will vary depending upon the individual case. Any comments on the amount of time you require to complete this form and/or suggestions for reducing this burden, should be sent to the Chief Information Officer, U.S. Patent and Trademark Office, U.S. Department of Commerce, P.O. Box 1450, Alexandria, Virginia 22313-1450. DO NOT SEND FEES OR COMPLETED FORMS TO THIS ADDRESS. SEND TO: Commissioner for Patents, P.O. Box 1450, Alexandria, Virginia 22313-1450. Under the Paperwork Reduction Act of 1995, no persons are required to respond to a collection of information unless it displays a valid OMB control number.

### Privacy Act Statement

**The Privacy Act of 1974 (P.L. 93-579)** requires that you be given certain information in connection with your submission of the attached form related to a patent application or patent. Accordingly, pursuant to the requirements of the Act, please be advised that: (1) the general authority for the collection of this information is 35 U.S.C. 2(b)(2); (2) furnishing of the information solicited is voluntary; and (3) the principal purpose for which the information is used by the U.S. Patent and Trademark Office is to process and/or examine your submission related to a patent application or patent. If you do not furnish the requested information, the U.S. Patent and Trademark Office may not be able to process and/or examine your submission, which may result in termination of proceedings or abandonment of the application or expiration of the patent.

The information provided by you in this form will be subject to the following routine uses:

1. The information on this form will be treated confidentially to the extent allowed under the Freedom of Information Act (5 U.S.C. 552) and the Privacy Act (5 U.S.C. 552a). Records from this system of records may be disclosed to the Department of Justice to determine whether disclosure of these records is required by the Freedom of Information Act.
2. A record from this system of records may be disclosed, as a routine use, in the course of presenting evidence to a court, magistrate, or administrative tribunal, including disclosures to opposing counsel in the course of settlement negotiations.
3. A record in this system of records may be disclosed, as a routine use, to a Member of Congress submitting a request involving an individual, to whom the record pertains, when the individual has requested assistance from the Member with respect to the subject matter of the record.
4. A record in this system of records may be disclosed, as a routine use, to a contractor of the Agency having need for the information in order to perform a contract. Recipients of information shall be required to comply with the requirements of the Privacy Act of 1974, as amended, pursuant to 5 U.S.C. 552a(m).
5. A record related to an International Application filed under the Patent Cooperation Treaty in this system of records may be disclosed, as a routine use, to the International Bureau of the World Intellectual Property Organization, pursuant to the Patent Cooperation Treaty.
6. A record in this system of records may be disclosed, as a routine use, to another federal agency for purposes of National Security review (35 U.S.C. 181) and for review pursuant to the Atomic Energy Act (42 U.S.C. 218(c)).
7. A record from this system of records may be disclosed, as a routine use, to the Administrator, General Services, or his/her designee, during an inspection of records conducted by GSA as part of that agency's responsibility to recommend improvements in records management practices and programs, under authority of 44 U.S.C. 2904 and 2906. Such disclosure shall be made in accordance with the GSA regulations governing inspection of records for this purpose, and any other relevant (i.e., GSA or Commerce) directive. Such disclosure shall not be used to make determinations about individuals.
8. A record from this system of records may be disclosed, as a routine use, to the public after either publication of the application pursuant to 35 U.S.C. 122(b) or issuance of a patent pursuant to 35 U.S.C. 151. Further, a record may be disclosed, subject to the limitations of 37 CFR 1.14, as a routine use, to the public if the record was filed in an application which became abandoned or in which the proceedings were terminated and which application is referenced by either a published application, an application open to public inspection or an issued patent.
9. A record from this system of records may be disclosed, as a routine use, to a Federal, State, or local law enforcement agency, if the USPTO becomes aware of a violation or potential violation of law or regulation.

<b>Notice of Allowability</b>	<b>Application No.</b> 15/495,539	<b>Applicant(s)</b> Da Silva et al.	
	<b>Examiner</b> GINA M MCKIE	<b>Art Unit</b> 2631	<b>AIA (FITF) Status</b> No

**-- The MAILING DATE of this communication appears on the cover sheet with the correspondence address--**

All claims being allowable, PROSECUTION ON THE MERITS IS (OR REMAINS) CLOSED in this application. If not included herewith (or previously mailed), a Notice of Allowance (PTOL-85) or other appropriate communication will be mailed in due course. **THIS NOTICE OF ALLOWABILITY IS NOT A GRANT OF PATENT RIGHTS.** This application is subject to withdrawal from issue at the initiative of the Office or upon petition by the applicant. See 37 CFR 1.313 and MPEP 1308.

1.  This communication is responsive to the RCE filed January 07, 2020.
  - A declaration(s)/affidavit(s) under **37 CFR 1.130(b)** was/were filed on \_\_\_\_\_.
2.  An election was made by the applicant in response to a restriction requirement set forth during the interview on \_\_\_\_\_; the restriction requirement and election have been incorporated into this action.
3.  The allowed claim(s) is/are 2-8,10-18 and 21-23 . As a result of the allowed claim(s), you may be eligible to benefit from the **Patent Prosecution Highway** program at a participating intellectual property office for the corresponding application. For more information , please see [http://www.uspto.gov/patents/init\\_events/pph/index.jsp](http://www.uspto.gov/patents/init_events/pph/index.jsp) or send an inquiry to [PPHfeedback@uspto.gov](mailto:PPHfeedback@uspto.gov).
4.  Acknowledgment is made of a claim for foreign priority under 35 U.S.C. § 119(a)-(d) or (f).

**Certified copies:**

- a)  All      b)  Some      \*c)  None of the:
1.  Certified copies of the priority documents have been received.
  2.  Certified copies of the priority documents have been received in Application No. \_\_\_\_\_ .
  3.  Copies of the certified copies of the priority documents have been received in this national stage application from the International Bureau (PCT Rule 17.2(a)).

\* Certified copies not received: \_\_\_\_\_ .

Applicant has THREE MONTHS FROM THE "MAILING DATE" of this communication to file a reply complying with the requirements noted below. Failure to timely comply will result in ABANDONMENT of this application.

**THIS THREE-MONTH PERIOD IS NOT EXTENDABLE.**

5.  CORRECTED DRAWINGS (as "replacement sheets") must be submitted.
  - including changes required by the attached Examiner's Amendment / Comment or in the Office action of Paper No./Mail Date \_\_\_\_\_ .

**Identifying indicia such as the application number (see 37 CFR 1.84(c)) should be written on the drawings in the front (not the back) of each sheet. Replacement sheet(s) should be labeled as such in the header according to 37 CFR 1.121(d).**
6.  DEPOSIT OF and/or INFORMATION about the deposit of BIOLOGICAL MATERIAL must be submitted. Note the attached Examiner's comment regarding REQUIREMENT FOR THE DEPOSIT OF BIOLOGICAL MATERIAL.

**Attachment(s)**

- |   |  |
|---|--|
| 1. <input checked="" type="checkbox"/> Notice of References Cited (PTO-892)                                       | 5. <input type="checkbox"/> Examiner's Amendment/Comment                             |
| 2. <input type="checkbox"/> Information Disclosure Statements (PTO/SB/08),<br>Paper No./Mail Date _____.          | 6. <input checked="" type="checkbox"/> Examiner's Statement of Reasons for Allowance |
| 3. <input type="checkbox"/> Examiner's Comment Regarding Requirement for Deposit<br>of Biological Material _____. | 7. <input type="checkbox"/> Other _____.   |
| 4. <input type="checkbox"/> Interview Summary (PTO-413),<br>Paper No./Mail Date _____.                            |  |

/GINA M MCKIE/ Examiner, Art Unit 2631	/SHUWANG LIU/ Supervisory Patent Examiner, Art Unit 2631
---	---

**DETAILED ACTION**

***Notice of Pre-AIA or AIA Status***

1. The present application, filed on or after March 16, 2013, is being examined under the first inventor to file provisions of the AIA.

***Response to Amendment***

2. Acknowledgement is made of the amendment filed January 07, 2020. Claims 2-8, 10-18 and 21-23 remain pending in the application.

- Claims 2, 7 and 17 are currently amended.
- Claims 1, 9, 19 and 20 are canceled.
- Claims 21-23 are newly added.

***Response to Arguments***

3. Applicant's arguments, see REMARKS, filed January 07, 2020, with respect to claim 19 rejected under 35 U.S.C. 112(d) or pre-AIA 35 U.S.C. 112, 4th paragraph, as being of improper dependent form for failing to further limit the subject matter of the claim upon which it depends, or for failing to include all the limitations of the claim upon which it depends, have been fully considered and are persuasive. The rejection is withdrawn in view of amendment filed January 07, 2020 which cancelled claim 19.

***Allowable Subject Matter***

4. Claims 2-8, 10-18 and 21-23 are allowed.

5. The following is an examiner's statement of reasons for allowance:

The prior art of record, Chen et al. (US 2002/0137538 A1) in view of Ishii et al. (US 6,714,584), fails to teach, "The prior art of record does not specifically teach, "receive a first signal transmission from a remote station via the first antenna element and a second signal transmission from the remote station via the second antenna element simultaneously," as recited in claim 2.

The prior art of record does not specifically teach, "determine a plurality of signal strength indications for the first signal transmission; determine a first signal strength average based on the plurality of signal strength indications for the first signal transmission; determine a plurality of signal strength indications for the second signal transmission; determine a second signal strength average based on the plurality of signal strength indications for the second signal transmission; and cause the transceiver to generate a fourth signal based on the first signal strength average and the second signal strength average" as recited in claim 7.

The prior art of record does not specifically teach, "wherein the first signal transmission and the second signal transmission comprise electromagnetic signals comprising one or more transmission peaks and one or more transmission nulls," as recited in claim 11.

The prior art of record does not specifically teach, "determine a set of weighting values based on the first signal information and the second signal information, wherein the first signal information comprises one or more of: a transmit power level, a data transmit rate, an antenna direction, quality of service data, or timing data," as recited in claim 17,

Chen is an exemplary reference in the relevant field of endeavor. Chen discloses wireless communications with an adaptive antenna array. Systems and techniques for parallel demodulation and searching using an adaptive antenna array with a processor configured to control the adaptive antenna

to search for a first signal with the first beam and to receive a second signal for demodulation with a second beam. However, Chen fails to teach the above limitations as recited in claims 2, 7, 11 and 17.

Ishii is another exemplary reference in the relevant field of endeavor. Ishii discloses CDMA adaptive antenna receiving apparatus and communication system. A CDMA adaptive antenna receiving apparatus is provided with plural receivers of which each is for receiving one or more of desired signal components incoming at the same time. Each of the plural receivers includes plural adaptive receiving units for updating sequentially a directivity in accordance with one desired signal component. The plural adaptive receiving units which are included in the same receiver employ a symbol decision error of the same receiver in common. Each receiver further includes a means for detecting the incoming directions of the plural desired signal components and a means for controlling directivities of the plural adaptive receiving units in accordance with the incoming directions of the plural desired signal components and directivities of the plural adaptive receiving units. However, Ishii fails to teach the above limitations as recited in claims 2, 7, 11 and 17.

For these reasons claims 2-8, 10-18 and 21-23 are allowed over the prior art of record.

Any comments considered necessary by applicant must be submitted no later than the payment of the issue fee and, to avoid processing delays, should preferably accompany the issue fee. Such submissions should be clearly labeled "Comments on Statement of Reasons for Allowance."

***Conclusion***

Any inquiry concerning this communication or earlier communications from the examiner should be directed to GINA M MCKIE whose telephone number is (571)270-5148. The examiner can normally be reached on Monday-Friday 9AM-5PM ET.

Examiner interviews are available via telephone, in-person, and video conferencing using a USPTO supplied web-based collaboration tool. To schedule an interview, applicant is encouraged to use the USPTO Automated Interview Request (AIR) at <http://www.uspto.gov/interviewpractice>.

If attempts to reach the examiner by telephone are unsuccessful, the examiner's supervisor, Shuwang Liu can be reached on 571-272-3036. The fax phone number for the organization where this application or proceeding is assigned is 571-273-8300.

Information regarding the status of an application may be obtained from the Patent Application Information Retrieval (PAIR) system. Status information for published applications may be obtained from either Private PAIR or Public PAIR. Status information for unpublished applications is available through Private PAIR only. For more information about the PAIR system, see <http://pair-direct.uspto.gov>. Should you have questions on access to the Private PAIR system, contact the Electronic Business Center (EBC) at 866-217-9197 (toll-free). If you would like assistance from a USPTO Customer Service Representative or access to the automated information system, call 800-786-9199 (IN USA OR CANADA) or 571-272-1000.

Application/Control Number: 15/495,539  
Art Unit: 2631

Page 6

GINA M. MCKIE  
Examiner  
Art Unit 2631

/GINA M MCKIE/  
Examiner, Art Unit 2631

/SHUWANG LIU/  
Supervisory Patent Examiner, Art Unit 2631



<b>Notice of References Cited</b>	Application/Control No. 15/495,539	Applicant(s)/Patent Under Reexamination Da Silva et al.	
	Examiner GINA M MCKIE	Art Unit 2631	Page 1 of 1

**U.S. PATENT DOCUMENTS**

*	Document Number Country Code-Number-Kind Code	Date MM-YYYY	Name	CPC Classification	US Classification
*	A	US-20120009964-A1	01-2012	Gormley; Eamonn	H04B7/0634 455/509
	B				
	C				
	D				
	E				
	F				
	G				
	H				
	I				
	J				
	K				
	L				
	M				


**FOREIGN PATENT DOCUMENTS**

*	Document Number Country Code-Number-Kind Code	Date MM-YYYY	Country	Name	CPC Classification
	N				
	O				
	P				
	Q				
	R				
	S				
	T				

**NON-PATENT DOCUMENTS**

*	U	V	W	X
	Include as applicable: Author, Title Date, Publisher, Edition or Volume, Pertinent Pages)			


\*A copy of this reference is not being furnished with this Office action. (See MPEP § 707.05(a).)  
Dates in MM-YYYY format are publication dates. Classifications may be US or foreign.

<b>Issue Classification</b> 	<b>Application/Control No.</b> 15/495,539	<b>Applicant(s)/Patent Under Reexamination</b> Da Silva et al.
	<b>Examiner</b> GINA M MCKIE	<b>Art Unit</b> 2631

CPC						
Symbol					Type	Version
H04B	/	7	/	0617	F	2013-01-01
H04B	/	7	/	04	I	2013-01-01
H04W	/	16	/	28	I	2013-01-01
H04W	/	72	/	046	I	2013-01-01
H04B	/	7	/	0621	I	2013-01-01
H04B	/	17	/	318	I	2013-01-01

CPC Combination Sets				
Symbol	Type	Set	Ranking	Version

/GINA M MCKIE/ Examiner, Art Unit 2631 (Assistant Examiner)	27 February 2020 (Date)	<b>Total Claims Allowed:</b> 19	
/SHUWANG LIU/ Supervisory Patent Examiner, Art Unit 2631 (Primary Examiner)	28 February 2020 (Date)	O.G. Print Claim(s) 1	O.G. Print Figure 2

<b>Issue Classification</b> 	<b>Application/Control No.</b> 15/495,539	<b>Applicant(s)/Patent Under Reexamination</b> Da Silva et al.
	<b>Examiner</b> GINA M MCKIE	<b>Art Unit</b> 2631


INTERNATIONAL CLASSIFICATION			
CLAIMED			
H04B7/06		7	06
H04B7/04		7	04
H04W16/28		16	28
H04W72/04		72	04
H04B17/318		17	318

NON-CLAIMED			

US ORIGINAL CLASSIFICATION	
CLASS	SUBCLASS

CROSS REFERENCES(S)						
CLASS	SUBCLASS (ONE SUBCLASS PER BLOCK)					


/GINA M MCKIE/ Examiner, Art Unit 2631 (Assistant Examiner)	27 February 2020 (Date)	<b>Total Claims Allowed:</b> 19	
/SHUWANG LIU/ Supervisory Patent Examiner, Art Unit 2631 (Primary Examiner)	28 February 2020 (Date)	O.G. Print Claim(s) 1	O.G. Print Figure 2

<b>Issue Classification</b> 	<b>Application/Control No.</b> 15/495,539	<b>Applicant(s)/Patent Under Reexamination</b> Da Silva et al.
	<b>Examiner</b> GINA M MCKIE	<b>Art Unit</b> 2631

Claims renumbered in the same order as presented by applicant  
  CPA  
  T.D.  
  R.1.47

CLAIMS															
Final	Original	Final	Original	Final	Original	Final	Original	Final	Original	Final	Original	Final	Original	Final	Original
	1	9	10		19										
1	2	8	11		20										
2	3	10	12	17	21										
3	4	11	13	18	22										
5	5	12	14	19	23										
4	6	13	15												
6	7	14	16												
7	8	15	17												
	9	16	18												

/GINA M MCKIE/ Examiner, Art Unit 2631 (Assistant Examiner)	27 February 2020 (Date)	<b>Total Claims Allowed:</b> 19	
/SHUWANG LIU/ Supervisory Patent Examiner, Art Unit 2631 (Primary Examiner)	28 February 2020 (Date)	O.G. Print Claim(s) 1	O.G. Print Figure 2

<b><i>Search Notes</i></b> 	<b>Application/Control No.</b> 15/495,539	<b>Applicant(s)/Patent Under Reexamination</b> Da Silva et al.
	<b>Examiner</b> GINA M MCKIE	<b>Art Unit</b> 2631

<b>CPC - Searched*</b>		
<b>Symbol</b>	<b>Date</b>	<b>Examiner</b>
H04L7/042, H04L27/2675 (EAST keyword search)	6/22/2017	gmckie

<b>CPC Combination Sets - Searched*</b>		
<b>Symbol</b>	<b>Date</b>	<b>Examiner</b>


<b>US Classification - Searched*</b>			
<b>Class</b>	<b>Subclass</b>	<b>Date</b>	<b>Examiner</b>

\* See search history printout included with this form or the SEARCH NOTES box below to determine the scope of the search.

<b>Search Notes</b>		
<b>Search Notes</b>	<b>Date</b>	<b>Examiner</b>
Performed double patenting search in EAST	6/21/2017	gmckie
Performed initial prior art search in EAST	6/21/2017	gmckie
Updated prior art search in EAST	1/19/2018	gmckie
Updated prior art search in EAST	9/17/2018	gmckie

<b>Interference Search</b>			
<b>US Class/CPC Symbol</b>	<b>US Subclass/CPC Group</b>	<b>Date</b>	<b>Examiner</b>
	SEE SEARCH HISTORY	05/13/2019	gmckie
	SEE SEARCH HISTORY	02/27/2020	gmckie

/GINA M MCKIE/ Examiner, Art Unit 2631	
---	--

<b><i>Index of Claims</i></b> 	<b>Application/Control No.</b> 15/495,539	<b>Applicant(s)/Patent Under Reexamination</b> Da Silva et al.
	<b>Examiner</b> GINA M MCKIE	<b>Art Unit</b> 2631

✓	<b>Rejected</b>	-	<b>Cancelled</b>	N	<b>Non-Elected</b>	A	<b>Appeal</b>
=	<b>Allowed</b>	÷	<b>Restricted</b>	I	<b>Interference</b>	O	<b>Objected</b>

CLAIMS									
<input type="checkbox"/> Claims renumbered in the same order as presented by applicant <input type="checkbox"/> CPA <input type="checkbox"/> T.D. <input type="checkbox"/> R.1.47									
CLAIM		DATE							
Final	Original	05/13/2019	05/13/2019	05/13/2019	06/27/2019	02/27/2020			
	1	✓	✓	✓	-	-			
1	2	✓	✓	○	=	=			
2	3	✓	✓	✓	=	=			
3	4	✓	✓	✓	=	=			
5	5	✓	✓	○	=	=			
4	6	✓	✓	○	=	=			
6	7	✓	✓	○	=	=			
7	8	✓	✓	○	=	=			
	9	✓	✓	✓	-	-			
9	10	✓	✓	✓	=	=			
8	11	✓	✓	○	=	=			
10	12	✓	✓	✓	=	=			
11	13	✓	✓	○	=	=			
12	14	✓	✓	○	=	=			
13	15	✓	✓	○	=	=			
14	16	✓	✓	○	=	=			
15	17	✓	✓	✓	=	=			
16	18	✓	✓	○	=	=			
	19	✓	✓	○	✓	-			
	20	✓	✓	○	-	-			
17	21					=			
18	22					=			
19	23					=			

Serial No.: 15/495,539  
Attorney Docket No.: 1640-001.203

**IN THE UNITED STATES PATENT AND TRADEMARK OFFICE**

Applicant	: Marcus DaSilva
Serial No.	: 15/495,539
Filed	: April 24, 2017
For	: DIRECTED WIRELESS COMMUNICATION
Examiner	: McKie, Gina M
Art Unit	: 2631
Confirmation No.	: 1050

**OFFICE ACTION RESPONSE**

Commissioner for Patents  
P.O. Box 1450  
Alexandria, VA 22313-1450

Commissioner:

In response to the Office action transmitted July 5, 2019, please reconsider the above-captioned application in light of the following amendments and remarks.

**Amendments to the Claims** are set forth in the listing of the claims beginning on page 2 of this paper; and

**Remarks/Arguments** begin on page 8 of this paper.

## Electronic Patent Application Fee Transmittal

<b>Application Number:</b>	15495539			
<b>Filing Date:</b>	24-Apr-2017			
<b>Title of Invention:</b>	DIRECTED WIRELESS COMMUNICATION			
<b>First Named Inventor/Applicant Name:</b>	Marcus Da Silva			
<b>Filer:</b>	Glen L. Nuttall			
<b>Attorney Docket Number:</b>	1640-001.203			
Filed as Small Entity				
<b>Filing Fees for Utility under 35 USC 111(a)</b>				
<b>Description</b>	<b>Fee Code</b>	<b>Quantity</b>	<b>Amount</b>	<b>Sub-Total in USD(\$)</b>
<b>Basic Filing:</b>				
<b>Pages:</b>				
<b>Claims:</b>				
<b>Miscellaneous-Filing:</b>				
<b>Petition:</b>				
<b>Patent-Appeals-and-Interference:</b>				
<b>Post-Allowance-and-Post-Issuance:</b>				
<b>Extension-of-Time:</b>				



Description	Fee Code	Quantity	Amount	Sub-Total in USD(\$)
Extension - 3 months with \$0 paid	2253	1	700	700
<b>Miscellaneous:</b>				
<b>Total in USD (\$)</b>				<b>700</b>

## Electronic Acknowledgement Receipt

<b>EFS ID:</b>	38219121
<b>Application Number:</b>	15495539
<b>International Application Number:</b>	
<b>Confirmation Number:</b>	1050
<b>Title of Invention:</b>	DIRECTED WIRELESS COMMUNICATION
<b>First Named Inventor/Applicant Name:</b>	Marcus Da Silva
<b>Customer Number:</b>	22145
<b>Filer:</b>	Glen L. Nuttall
<b>Filer Authorized By:</b>	
<b>Attorney Docket Number:</b>	1640-001.203
<b>Receipt Date:</b>	07-JAN-2020
<b>Filing Date:</b>	24-APR-2017
<b>Time Stamp:</b>	02:09:07
<b>Application Type:</b>	Utility under 35 USC 111(a)

### Payment information:

Submitted with Payment	yes
Payment Type	CARD
Payment was successfully received in RAM	\$700
RAM confirmation Number	E202017311057551
Deposit Account	
Authorized User	

The Director of the USPTO is hereby authorized to charge indicated fees and credit any overpayment as follows:

<b>File Listing:</b>						
<b>Document Number</b>	<b>Document Description</b>	<b>File Name</b>	<b>File Size(Bytes)/ Message Digest</b>	<b>Multi Part /.zip</b>	<b>Pages (if appl.)</b>	
1	Miscellaneous Incoming Letter	CertificateEFS.pdf	77799 06cc9f0026db825458cd30121417c441ab5401d4	no	1	
<b>Warnings:</b>						
<b>Information:</b>						
2		1640-001-203RtoFOAof20190705.pdf	102787 f100370efb71d9cf61f2e0410756d9eefceede8e	yes	9	
<b>Multipart Description/PDF files in .zip description</b>						
		<b>Document Description</b>	<b>Start</b>	<b>End</b>		
		Applicant Arguments/Remarks Made in an Amendment	8	9		
		Claims	2	7		
		Amendment/Req. Reconsideration-After Non-Final Reject	1	1		
<b>Warnings:</b>						
<b>Information:</b>						
3	Fee Worksheet (SB06)	fee-info.pdf	30456 02e46d2296ad93ea95fbc9adddfce8695e856420a	no	2	
<b>Warnings:</b>						
<b>Information:</b>						
<b>Total Files Size (in bytes):</b>			211042			

**This Acknowledgement Receipt evidences receipt on the noted date by the USPTO of the indicated documents, characterized by the applicant, and including page counts, where applicable. It serves as evidence of receipt similar to a Post Card, as described in MPEP 503.**

**New Applications Under 35 U.S.C. 111**

**If a new application is being filed and the application includes the necessary components for a filing date (see 37 CFR 1.53(b)-(d) and MPEP 506), a Filing Receipt (37 CFR 1.54) will be issued in due course and the date shown on this Acknowledgement Receipt will establish the filing date of the application.**

**National Stage of an International Application under 35 U.S.C. 371**

**If a timely submission to enter the national stage of an international application is compliant with the conditions of 35 U.S.C. 371 and other applicable requirements a Form PCT/DO/EO/903 indicating acceptance of the application as a national stage submission under 35 U.S.C. 371 will be issued in addition to the Filing Receipt, in due course.**

**New International Application Filed with the USPTO as a Receiving Office**

**If a new international application is being filed and the international application includes the necessary components for an international filing date (see PCT Article 11 and MPEP 1810), a Notification of the International Application Number and of the International Filing Date (Form PCT/RO/105) will be issued in due course, subject to prescriptions concerning national security, and the date shown on this Acknowledgement Receipt will establish the international filing date of the application.**

IN THE UNITED STATES PATENT AND TRADEMARK OFFICE

Applicants: Marcus Da Silva et al.  
Title: DIRECTED WIRELESS COMMUNICATION  
Serial No.: 15/495,539 Filed: April 24, 2017  
Examiner: McKie, Gina M Group Art Unit: 2631  
Attorney Docket No.: 1640-001.203

---

**CERTIFICATE OF EFS-WEB TRANSMISSION  
UNDER 37 CFR § 1.8**

I hereby certify that the enclosed Office Action Response (9 pages) is being transmitted to the United States Patent and Trademark Office from the Pacific Time Zone via EFS-Web on January 6, 2020.

Date: January 6, 2020

/Glen L Nuttall/

Glen L Nuttall

Mailing Address:

**KLEIN, O'NEILL & SINGH, LLP (Customer No.: 22145)**  
16755 Von Karman Avenue, Suite 275  
Irvine, California 92606  
Tel: 949-955-1920  
Fax: 949-955-1921

Serial No.: 15/495,539  
Attorney Docket No.: 1640-001.203

## **REMARKS**

By this paper Claims 2, 7 and 17 have been amended, Claim 19 has been cancelled without prejudice, and new dependent Claims 21-23 have been added. As such, Claims 2-8, 10-18 and 21-23 are currently pending for consideration in this application.

### Rejection Under 35 USC 112

The Office Action rejected Claim 19 under 35 USC 112 as being of improper dependent form. Applicant has cancelled Claim 19, making the rejection moot.

### Amendments to Independent Claims Change Scope

Applicant has amended independent Claims 2, 7 and 17 to replace the recited “remote station” with “transceiver” in one instance in each claim. This amendment is a correction of an earlier error, and makes these claims read as intended. However, the amendment changes the scope of these claims. Thus, Applicant wishes to specifically bring it to the examiner’s attention.

### New Dependent Claims

New Claims 21 - 23 have been added. Each of the new claims depends from an already-allowed independent claim, and thus is considered to be allowable. Applicant submits that these claims also recite additional patentable subject matter.

The new claims are supported by the application as originally filed, which includes the specification and drawings as well as the provisional application and other priority applications (which applications have been expressly incorporated by reference). No new subject matter has been added by the new dependent claims.

### Conclusion

For the foregoing reasons, it is respectfully submitted that the rejections set forth in the outstanding Office action are inapplicable to the current claims. Accordingly, issuance of a Notice of Allowance is requested.

Serial No.: 15/495,539  
Attorney Docket No.: 1640-001.203

Please charge any additional fees, including any fees for additional extension of time, or credit overpayment to Deposit Account No. 11-1159.

Respectfully submitted,

Klein, O'Neill & Singh, LLP

Dated: January 6, 2020

By /Glen L Nuttall/  
Glen L Nuttall, Reg. No. 46,188  
Telephone: (949) 955-1920

Klein, O'Neill & Singh, LLP  
16755 Von Karman, Suite 275  
Irvine, CA 92606  
T (949) 955-1920  
F (949) 955-1921

### **AMENDMENTS TO THE CLAIMS**

Please amend the claims to read as follows. Additions are underlined. Deletions are in ~~strikeout~~ text or [[double brackets]].

1. (Cancelled)

2. (Currently Amended) A receiver for use in a wireless communications system, the receiver comprising:

an antenna, wherein the antenna comprises a first antenna element and a second antenna element;

a transceiver operatively coupled to the antenna and configured to transmit and receive electromagnetic signals using the antenna; and

a processor operatively coupled to the transceiver, the processor configured to:

receive a first signal transmission from a remote station via the first antenna element and a second signal transmission from the remote station via the second antenna element simultaneously;

determine first signal information for the first signal transmission;

determine second signal information for the second signal transmission, wherein the second signal information is different than the first signal information;

determine a set of weighting values based on the first signal information and the second signal information, wherein the set of weighting values is configured to be used by the ~~remote station transceiver~~ to construct one or more beam-formed transmission signals;

cause the transceiver to transmit a third signal to the remote station via the antenna, the third signal comprising content based on the set of weighting values.

3. (Previously Presented) The receiver as recited in Claim 2, wherein the first signal transmission and the second signal transmission comprise electromagnetic signals comprising one or more transmission peaks and one or more transmission nulls.

4. (Previously Presented) The receiver as recited in Claim 3, wherein the first signal



transmission and the second signal transmission are directional transmissions.

5. (Previously Presented) The receiver as recited in Claim 6, wherein the set of weighting values is further based on one or more of: a transmit power level, a data transmit rate, an antenna direction, quality of service data, or timing data.

6. (Previously Presented) The receiver as recited in Claim 2, wherein the content comprises data configured to be used by the remote station to modify the placement of one or more transmission peaks and one or more transmission nulls in a subsequent signal transmission.

7. (Currently Amended) A receiver for use in a wireless communications system, the receiver comprising:

an antenna;

a transceiver operatively coupled to the antenna and configured to transmit and receive electromagnetic signals using the antenna; and

a processor operatively coupled to the transceiver, the processor configured to:

receive a first signal transmission from a remote station via the antenna and a second signal transmission from the remote station via the antenna simultaneously;

determine first signal information for the first signal transmission;

determine second signal information for the second signal transmission, wherein the second signal information is different than the first signal information;

determine a set of weighting values based on the first signal information and the second signal information, wherein the set of weighting values is configured to be used by the ~~remote station transceiver~~ to construct one or more beam-formed transmission signals;

cause the transceiver to generate a third signal comprising content based on the set of weighting values;

determine a plurality of signal strength indications for the first signal transmission;

determine a first signal strength average based on the plurality of signal

strength indications for the first signal transmission;  
determine a plurality of signal strength indications for the second signal transmission;  
determine a second signal strength average based on the plurality of signal strength indications for the second signal transmission; and  
cause the transceiver to generate a fourth signal based on the first signal strength average and the second signal strength average.

8. (Previously Presented) The receiver as recited in Claim 7, wherein the processor is further configured to: cause the transceiver to transmit the fourth signal to the remote station via the antenna.

9. (Cancelled)

10. (Previously Presented) The method as recited in Claim 11, further comprising: transmitting the third signal to the remote station via the antenna.

11. (Previously Presented) A method in a wireless communications system, the method comprising:

receiving a first signal transmission from a remote station via a first antenna element of an antenna and a second signal transmission from the remote station via a second antenna element of the antenna simultaneously, wherein the first signal transmission and the second signal transmission comprise electromagnetic signals comprising one or more transmission peaks and one or more transmission nulls;

determining first signal information for the first signal transmission;

determining second signal information for the second signal transmission, wherein the second signal information is different than the first signal information;

determining a set of weighting values based on the first signal information and the second signal information, wherein the set of weighting values is configured to be used by the remote station to construct one or more beam-formed transmission signals; and

transmitting to the remote station a third signal comprising content based on the set of

weighting values.

12. (Previously Presented) The method as recited in Claim 11, wherein the first signal transmission and the second signal transmission are directional transmissions.

13. (Previously Presented) The method as recited in Claim 11, wherein the set of weighting values is further based on one or more of: a transmit power level, a data transmit rate, an antenna direction, quality of service data, or timing data.

14. (Previously Presented) The method as recited in Claim 13, wherein the content comprises data configured to be used by the remote station to modify the placement of one or more transmission peaks and one or more transmission nulls in a subsequent signal transmission.

15. (Previously Presented) The method as recited in Claim 14, further comprising:  
determining a plurality of signal strength indications for the first signal transmission;  
determining a first signal strength average based on the plurality of signal strength indications for the first signal transmission;

determining a plurality of signal strength indications for the second signal transmission;

determining a second signal strength average based on the plurality of signal strength indications for the second signal transmission; and

generating a fourth signal based on the first signal strength average and the second signal strength average.

16. (Previously Presented) The method as recited in Claim 15, further comprising: causing the transceiver to transmit the fourth signal to the remote station via the antenna.

17. (Currently Amended) An apparatus for use in a wireless communications system, the apparatus comprising:

an antenna;

a transceiver operatively coupled to the antenna; and

a processor operatively coupled to the transceiver, the processor configured to:

receive a first signal transmission from a remote station via the antenna,  
the first signal transmission comprising first signal information, wherein the first signal information comprises one or more of: a transmit power level, a data transmit rate, an antenna direction, quality of service data, or timing data;

receive a second signal transmission from the remote station via the antenna,  
the second signal transmission comprising second signal information;

determine a set of weighting values based on the first signal information and the second signal information, wherein the set of weighting values is configured to be used by the ~~remote station transceiver~~ to construct one or more beam-formed transmission signals;

cause the transceiver to generate a third signal comprising content based on the set of weighting values.

18. (Previously Presented) The apparatus as recited in Claim 17, wherein the first signal transmission and the second signal transmission comprise electromagnetic signals comprising one or more transmission peaks and one or more transmission nulls.

19. (Cancelled)

20. (Cancelled)

21. (New) The apparatus as recited in Claim 18, wherein the processor is configured to receive a fourth signal transmission from an interferer source, the fourth signal transmission being undesired, and the processor is configured to store identifying information concerning the undesired interferer source and the remote station.

22. (New) The apparatus as recited in Claim 21, wherein the processor is configured to identify a further interferer signal transmission from the interferer source, and to identify a further desired signal transmission from the remote station, wherein the processor is further configured to prevent the transceiver from transmitting a fifth signal transmission via the antenna during reception of the further desired signal transmission but to allow the transceiver to transmit a sixth signal transmission via the antenna during reception of the further interferer signal transmission.

Serial No.: 15/495,539

Attorney Docket No.: 1640-001.203

23. (New) The apparatus as recited in Claim 17, wherein the set of weighting values are applied to the third signal, and wherein the transceiver is configured to receive a fourth signal transmitted from the remote station, and the processor is configured to apply the set of weighting values to the fourth signal.

Under the Paperwork Reduction Act of 1995, no persons are required to respond to a collection of information unless it contains a valid OMB control number.

<p style="text-align: center;"><b>Request for Continued Examination (RCE) Transmittal</b></p> <p>Address to: Mail Stop RCE Commissioner for Patents P.O. Box 1450 Alexandria, VA 22313-1450</p>	Application Number	15/495,539
	Filing Date	April 24, 2017
	First Named Inventor	Marcus Da Silva
	Art Unit	2631
	Examiner Name	Mckie, Gina M.
	Attorney Docket Number	1640-001.203

**This is a Request for Continued Examination (RCE) under 37 CFR 1.114 of the above-identified application.**  
 Request for Continued Examination (RCE) practice under 37 CFR 1.114 does not apply to any utility or plant application filed prior to June 8, 1995, or to any design application. See Instruction Sheet for RCEs (not to be submitted to the USPTO) on page 2.

1. **Submission required under 37 CFR 1.114** Note: If the RCE is proper, any previously filed unentered amendments and amendments enclosed with the RCE will be entered in the order in which they were filed unless applicant instructs otherwise. If applicant does not wish to have any previously filed unentered amendment(s) entered, applicant must request non-entry of such amendment(s).

a.  Previously submitted. If a final Office action is outstanding, any amendments filed after the final Office action may be considered as a submission even if this box is not checked.

i.  Consider the arguments in the Appeal Brief or Reply Brief previously filed on \_\_\_\_\_

ii.  Other \_\_\_\_\_

b.  Enclosed

i.  Amendment/Reply

ii.  Affidavit(s)/ Declaration(s)

iii.  Information Disclosure Statement (IDS)

iv.  Other \_\_\_\_\_

2. **Miscellaneous**

a.  Suspension of action on the above-identified application is requested under 37 CFR 1.103(c) for a period of \_\_\_\_\_ months. (Period of suspension shall not exceed 3 months; Fee under 37 CFR 1.17(i) required)

b.  Other \_\_\_\_\_

3. **Fees** The RCE fee under 37 CFR 1.17(e) is required by 37 CFR 1.114 when the RCE is filed.

a.  The Director is hereby authorized to charge the following fees, any underpayment of fees, or credit any overpayments, to Deposit Account No. 11-1159.

i.  RCE fee required under 37 CFR 1.17(e)

ii.  Extension of time fee (37 CFR 1.136 and 1.17)

iii.  Other \_\_\_\_\_

b.  Check in the amount of \$ \_\_\_\_\_ enclosed

c.  Payment by credit card (Form PTO-2038 enclosed)

d.  Payment by EFS-Web

**WARNING: Information on this form may become public. Credit card information should not be included on this form. Provide credit card information and authorization on PTO-2038.**

SIGNATURE OF APPLICANT, ATTORNEY, OR AGENT REQUIRED			
Signature	/Glen L. Nuttall/	Date	January 6, 2020
Name (Print/Type)	Glen L. Nuttall	Registration No.	46,188

CERTIFICATE OF MAILING OR TRANSMISSION			
I hereby certify that this correspondence is being EFS-Web transmitted to the United States Patent and Trademark Office (USPTO), deposited with the United States Postal Service with sufficient postage as first class mail in an envelope addressed to: Mail Stop RCE, Commissioner for Patents, P. O. Box 1450, Alexandria, VA 22313-1450 or facsimile transmitted to the USPTO on the date shown below.			
Signature	/Glen L. Nuttall/	Date	January 6, 2020
Name (Print/Type)	Glen L. Nuttall	Date	January 6, 2020

This collection of information is required by 37 CFR 1.114. The information is required to obtain or retain a benefit by the public which is to file (and by the USPTO to process) an application. Confidentiality is governed by 35 U.S.C. 122 and 37 CFR 1.11 and 1.14. This collection is estimated to take 12 minutes to complete, including gathering, preparing, and submitting the completed application form to the USPTO. Time will vary depending upon the individual case. Any comments on the amount of time you require to complete this form and/or suggestions for reducing this burden, should be sent to the Chief Information Officer, U.S. Patent and Trademark Office, U.S. Department of Commerce, P.O. Box 1450, Alexandria, VA 22313-1450. DO NOT SEND FEES OR COMPLETED FORMS TO THIS ADDRESS. SEND TO: Mail Stop RCE, Commissioner for Patents, P.O. Box 1450, Alexandria, VA 22313-1450.  
 If you need assistance in completing the form, call 1-800-PTO-9199 and select option 2.

## Electronic Patent Application Fee Transmittal

<b>Application Number:</b>	15495539			
<b>Filing Date:</b>	24-Apr-2017			
<b>Title of Invention:</b>	DIRECTED WIRELESS COMMUNICATION			
<b>First Named Inventor/Applicant Name:</b>	Marcus Da Silva			
<b>Filer:</b>	Glen L. Nuttall			
<b>Attorney Docket Number:</b>	1640-001.203			
Filed as Small Entity				
<b>Filing Fees for Utility under 35 USC 111(a)</b>				
<b>Description</b>	<b>Fee Code</b>	<b>Quantity</b>	<b>Amount</b>	<b>Sub-Total in USD(\$)</b>
<b>Basic Filing:</b>				
<b>Pages:</b>				
<b>Claims:</b>				
<b>Miscellaneous-Filing:</b>				
<b>Petition:</b>				
<b>Patent-Appeals-and-Interference:</b>				
<b>Post-Allowance-and-Post-Issuance:</b>				
<b>Extension-of-Time:</b>				

Description	Fee Code	Quantity	Amount	Sub-Total in USD(\$)
<b>Miscellaneous:</b>				
RCE- 2ND AND SUBSEQUENT REQUEST	2820	1	950	950
<b>Total in USD (\$)</b>				<b>950</b>



## Electronic Acknowledgement Receipt

<b>EFS ID:</b>	38219130
<b>Application Number:</b>	15495539
<b>International Application Number:</b>	
<b>Confirmation Number:</b>	1050
<b>Title of Invention:</b>	DIRECTED WIRELESS COMMUNICATION
<b>First Named Inventor/Applicant Name:</b>	Marcus Da Silva
<b>Customer Number:</b>	22145
<b>Filer:</b>	Glen L. Nuttall
<b>Filer Authorized By:</b>	
<b>Attorney Docket Number:</b>	1640-001.203
<b>Receipt Date:</b>	07-JAN-2020
<b>Filing Date:</b>	24-APR-2017
<b>Time Stamp:</b>	02:23:45
<b>Application Type:</b>	Utility under 35 USC 111(a)

### Payment information:

Submitted with Payment	yes
Payment Type	CARD
Payment was successfully received in RAM	\$950
RAM confirmation Number	E202017325117566
Deposit Account	
Authorized User	

The Director of the USPTO is hereby authorized to charge indicated fees and credit any overpayment as follows:

--	--	--	--	--	--

**File Listing:**

Document Number	Document Description	File Name	File Size(Bytes)/ Message Digest	Multi Part /.zip	Pages (if appl.)
1	Request for Continued Examination (RCE)	RCETransmittal-20200106.pdf	171005	no	1
			ca14b19aa64b93d0e3efc63182f17eeecb55c8aa		

**Warnings:**

This is not a USPTO supplied RCE SB30 form.

**Information:**

2	Fee Worksheet (SB06)	fee-info.pdf	30399	no	2
			982b9bc527cc76f02f531582348650789d8697d		

**Warnings:**

**Information:**

<b>Total Files Size (in bytes):</b>	201404
-------------------------------------	--------

**This Acknowledgement Receipt evidences receipt on the noted date by the USPTO of the indicated documents, characterized by the applicant, and including page counts, where applicable. It serves as evidence of receipt similar to a Post Card, as described in MPEP 503.**

**New Applications Under 35 U.S.C. 111**

If a new application is being filed and the application includes the necessary components for a filing date (see 37 CFR 1.53(b)-(d) and MPEP 506), a Filing Receipt (37 CFR 1.54) will be issued in due course and the date shown on this Acknowledgement Receipt will establish the filing date of the application.

**National Stage of an International Application under 35 U.S.C. 371**

If a timely submission to enter the national stage of an international application is compliant with the conditions of 35 U.S.C. 371 and other applicable requirements a Form PCT/DO/EO/903 indicating acceptance of the application as a national stage submission under 35 U.S.C. 371 will be issued in addition to the Filing Receipt, in due course.

**New International Application Filed with the USPTO as a Receiving Office**

If a new international application is being filed and the international application includes the necessary components for an international filing date (see PCT Article 11 and MPEP 1810), a Notification of the International Application Number and of the International Filing Date (Form PCT/RO/105) will be issued in due course, subject to prescriptions concerning national security, and the date shown on this Acknowledgement Receipt will establish the international filing date of the application.

<b>PATENT APPLICATION FEE DETERMINATION RECORD</b> Substitute for Form PTO-875		Application or Docket Number 15/495,539	Filing Date 04/24/2017	<input type="checkbox"/> To be Mailed		
ENTITY: <input type="checkbox"/> LARGE <input checked="" type="checkbox"/> SMALL <input type="checkbox"/> MICRO						
<b>APPLICATION AS FILED - PART I</b>						
	(Column 1)	(Column 2)				
FOR	NUMBER FILED	NUMBER EXTRA	RATE (\$)	FEE (\$)		
<input type="checkbox"/> BASIC FEE <small>(37 CFR 1.16(a), (b), or (c))</small>	N/A	N/A	N/A			
<input type="checkbox"/> SEARCH FEE <small>(37 CFR 1.16(k), (l), or (m))</small>	N/A	N/A	N/A			
<input type="checkbox"/> EXAMINATION FEE <small>(37 CFR 1.16(o), (p), or (q))</small>	N/A	N/A	N/A			
TOTAL CLAIMS <small>(37 CFR 1.16(j))</small>	minus 20 = *		x \$40 =			
INDEPENDENT CLAIMS <small>(37 CFR 1.16(h))</small>	minus 3 = *		x \$210 =			
<input type="checkbox"/> APPLICATION SIZE FEE (37 CFR 1.16(s))	If the specification and drawings exceed 100 sheets of paper, the application size fee due is \$310 (\$155 for small entity) for each additional 50 sheets or fraction thereof. See 35 U.S.C. 41(a)(1)(G) and 37 CFR 1.16(s).					
<input type="checkbox"/> MULTIPLE DEPENDENT CLAIM PRESENT (37 CFR 1.16(j))						
* If the difference in column 1 is less than zero, enter "0" in column 2.			TOTAL			
<b>APPLICATION AS AMENDED - PART II</b>						
	(Column 1)	(Column 2)	(Column 3)			
AMENDMENT	01/07/2020 CLAIMS REMAINING AFTER AMENDMENT	HIGHEST NUMBER PREVIOUSLY PAID FOR	PRESENT EXTRA	RATE (\$)	ADDITIONAL FEE (\$)	
Total <small>(37 CFR 1.16(i))</small>	* 19	Minus ** 20	= 0	x \$ 50 =	0	
Independent <small>(37 CFR 1.16(h))</small>	* 4	Minus *** 4	= 0	x \$ 230 =	0	
<input type="checkbox"/> Application Size Fee (37 CFR 1.16(s))						
<input type="checkbox"/> FIRST PRESENTATION OF MULTIPLE DEPENDENT CLAIM (37 CFR 1.16(j))						
					TOTAL ADD'L FEE	0
AMENDMENT	CLAIMS REMAINING AFTER AMENDMENT	HIGHEST NUMBER PREVIOUSLY PAID FOR	PRESENT EXTRA	RATE (\$)	ADDITIONAL FEE (\$)	
Total <small>(37 CFR 1.16(i))</small>	*	Minus **	=	x \$ 0 =		
Independent <small>(37 CFR 1.16(h))</small>	*	Minus ***	=	x \$ 0 =		
<input type="checkbox"/> Application Size Fee (37 CFR 1.16(s))						
<input type="checkbox"/> FIRST PRESENTATION OF MULTIPLE DEPENDENT CLAIM (37 CFR 1.16(j))						
					TOTAL ADD'L FEE	
* If the entry in column 1 is less than the entry in column 2, write "0" in column 3.					LIE	
** If the "Highest Number Previously Paid For" IN THIS SPACE is less than 20, enter "20".					/MARQUITA D JONES/	
*** If the "Highest Number Previously Paid For" IN THIS SPACE is less than 3, enter "3".						
The "Highest Number Previously Paid For" (Total or Independent) is the highest number found in the appropriate box in column 1.						

This collection of information is required by 37 CFR 1.16. The information is required to obtain or retain a benefit by the public which is to file (and by the USPTO to process) an application. Confidentiality is governed by 35 U.S.C. 122 and 37 CFR 1.14. This collection is estimated to take 12 minutes to complete, including gathering, preparing, and submitting the completed application form to the USPTO. Time will vary depending upon the individual case. Any comments on the amount of time you require to complete this form and/or suggestions for reducing this burden, should be sent to the Chief Information Officer, U.S. Patent and Trademark Office, U.S. Department of Commerce, P.O. Box 1450, Alexandria, VA 22313-1450. DO NOT SEND FEES OR COMPLETED FORMS TO THIS ADDRESS. **SEND TO: Commissioner for Patents, P.O. Box 1450, Alexandria, VA 22313-1450.**

*If you need assistance in completing the form, call 1-800-PTO-9199 and select option 2.*



UNITED STATES PATENT AND TRADEMARK OFFICE

UNITED STATES DEPARTMENT OF COMMERCE  
**United States Patent and Trademark Office**  
Address: COMMISSIONER FOR PATENTS  
P.O. Box 1450  
Alexandria, Virginia 22313-1450  
www.uspto.gov

APPLICATION NO.	FILING DATE	FIRST NAMED INVENTOR	ATTORNEY DOCKET NO.	CONFIRMATION NO.
15/495,539	04/24/2017	Marcus Da Silva	1640-001.203	1050
22145	7590	07/05/2019	EXAMINER	
KLEIN, O'NEILL & SINGH, LLP 16755 VON KARMAN AVENUE SUITE 275 IRVINE, CA 92606			MCKIE, GINA M	
			ART UNIT	PAPER NUMBER
			2631	
			NOTIFICATION DATE	DELIVERY MODE
			07/05/2019	ELECTRONIC

**Please find below and/or attached an Office communication concerning this application or proceeding.**

The time period for reply, if any, is set in the attached communication.

Notice of the Office communication was sent electronically on above-indicated "Notification Date" to the following e-mail address(es):

KOS\_Docketing@koslaw.com



**DETAILED ACTION**

***Notice of Pre-AIA or AIA Status***

1. The present application is being examined under the pre-AIA first to invent provisions.

***Response to Amendment***

2. Acknowledgement is made of the amendment filed March 27, 2019. Claims 2-8 and 10-19 remain pending in the application.
  - Claims 2-7, 10-17 and 19 are currently amended.
  - Claims 1, 9 and 20 have been canceled.
  - No claims are new.

***Response to Arguments***

3. Applicant's arguments, see REMARKS, filed March 27, 2019, with respect to claims 1, 3, 4, 9, 10, 12 and 17 rejected under 35 U.S.C. 103 as being unpatentable over Chen et al. (US 2002/0137538 A1) in view of Ishii et al. (US 6,714,584), have been fully considered and are persuasive. The rejection of claims 1, 3, 4, 9, 10, 12 and 17 has been withdrawn.

***Claim Rejections - 35 USC § 112***

4. (d) REFERENCE IN DEPENDENT FORMS.—Subject to subsection (e), a claim in dependent form shall contain a reference to a claim previously set forth and then specify a further limitation of the subject matter claimed. A claim in dependent form shall be construed to incorporate by reference all the limitations of the claim to which it refers.

The following is a quotation of pre-AIA 35 U.S.C. 112, fourth paragraph:

Subject to the following paragraph [i.e., the fifth paragraph of pre-AIA 35 U.S.C. 112], a claim in dependent form shall contain a reference to a claim previously set forth and then specify a further limitation of the subject matter claimed. A claim in dependent form shall be construed to incorporate by reference all the limitations of the claim to which it refers.

5. Claim 19 is rejected under 35 U.S.C. 112(d) or pre-AIA 35 U.S.C. 112, 4th paragraph, as being of improper dependent form for failing to further limit the subject matter of the claim upon which it depends, or for failing to include all the limitations of the claim upon which it depends. Claim 19 recites Applicant may cancel the claim(s), amend the claim(s) to place the claim(s) in proper dependent form, rewrite the claim(s) in independent form, or present a sufficient showing that the dependent claim(s) complies with the statutory requirements.

***Allowable Subject Matter***

6. Claims 2-8 and 10-18 are allowed.

The following is a statement of reasons for the indication of allowable subject matter:

The prior art of record does not specifically teach, “receive a first signal transmission from a remote station via the first antenna element and a second signal transmission from the remote station via the second antenna element simultaneously,” as recited in claim 2.

The prior art of record does not specifically teach, “determine a plurality of signal strength indications for the first signal transmission; determine a first signal strength average based on the plurality of signal strength indications for the first signal transmission; determine a plurality of signal strength indications for the second signal transmission; determine a second signal strength average

based on the plurality of signal strength indications for the second signal transmission; and cause the transceiver to generate a fourth signal based on the first signal strength average and the second signal strength average” as recited in claim 7.

The prior art of record does not specifically teach, “wherein the first signal transmission and the second signal transmission comprise electromagnetic signals comprising one or more transmission peaks and one or more transmission nulls,” as recited in claim 11.

The prior art of record does not specifically teach, “determine a set of weighting values based on the first signal information and the second signal information, wherein the first signal information comprises one or more of: a transmit power level, a data transmit rate, an antenna direction, quality of service data, or timing data,” as recited in claim 17.

#### ***Conclusion***

Applicant's amendment necessitated the new ground(s) of rejection presented in this Office action. Accordingly, **THIS ACTION IS MADE FINAL**. See MPEP § 706.07(a). Applicant is reminded of the extension of time policy as set forth in 37 CFR 1.136(a).

A shortened statutory period for reply to this final action is set to expire THREE MONTHS from the mailing date of this action. In the event a first reply is filed within TWO MONTHS of the mailing date of this final action and the advisory action is not mailed until after the end of the THREE-MONTH shortened statutory period, then the shortened statutory period will expire on the date the advisory action is mailed, and any extension fee pursuant to 37 CFR 1.136(a) will be calculated from the mailing date of the advisory action. In no event, however, will the statutory period for reply expire later than SIX MONTHS from the date of this final action.



Any inquiry concerning this communication or earlier communications from the examiner should be directed to GINA M MCKIE whose telephone number is (571)270-5148. The examiner can normally be reached on Monday-Friday 9AM-5PM ET.

Examiner interviews are available via telephone, in-person, and video conferencing using a USPTO supplied web-based collaboration tool. To schedule an interview, applicant is encouraged to use the USPTO Automated Interview Request (AIR) at <http://www.uspto.gov/interviewpractice>.

If attempts to reach the examiner by telephone are unsuccessful, the examiner's supervisor, Shuwang Liu can be reached on 571-272-3036. The fax phone number for the organization where this application or proceeding is assigned is 571-273-8300.

Information regarding the status of an application may be obtained from the Patent Application Information Retrieval (PAIR) system. Status information for published applications may be obtained from either Private PAIR or Public PAIR. Status information for unpublished applications is available through Private PAIR only. For more information about the PAIR system, see <http://pair-direct.uspto.gov>. Should you have questions on access to the Private PAIR system, contact the Electronic Business Center (EBC) at 866-217-9197 (toll-free). If you would like assistance from a USPTO Customer Service Representative or access to the automated information system, call 800-786-9199 (IN USA OR CANADA) or 571-272-1000.

GINA M. MCKIE  
Examiner  
Art Unit 2631

/GINA M MCKIE/  
Examiner, Art Unit 2631

/SHUWANG LIU/  
Supervisory Patent Examiner, Art Unit 2631

<b>Notice of References Cited</b>	Application/Control No. 15/495,539	Applicant(s)/Patent Under Reexamination Da Silva et al.	
	Examiner GINA M MCKIE	Art Unit 2631	Page 1 of 1

**U.S. PATENT DOCUMENTS**

*	Document Number Country Code-Number-Kind Code	Date MM-YYYY	Name	CPC Classification	US Classification
*	A US-20130094454-A1	04-2013	Soriaga; Joseph B.	H04B7/0691	370/329
B					
C					
D					
E					
F					
G					
H					
I					
J					
K					
L					
M					


**FOREIGN PATENT DOCUMENTS**

*	Document Number Country Code-Number-Kind Code	Date MM-YYYY	Country	Name	CPC Classification
N					
O					
P					
Q					
R					
S					
T					

**NON-PATENT DOCUMENTS**

*	U	V	W	X
	Include as applicable: Author, Title Date, Publisher, Edition or Volume, Pertinent Pages)			

\*A copy of this reference is not being furnished with this Office action. (See MPEP § 707.05(a).)  
Dates in MM-YYYY format are publication dates. Classifications may be US or foreign.

<b><i>Search Notes</i></b> 	<b>Application/Control No.</b> 15/495,539	<b>Applicant(s)/Patent Under Reexamination</b> Da Silva et al.
	<b>Examiner</b> GINA M MCKIE	<b>Art Unit</b> 2631

<b>CPC - Searched*</b>		
<b>Symbol</b>	<b>Date</b>	<b>Examiner</b>
H04L7/042, H04L27/2675 (EAST keyword search)	6/22/2017	gmckie

<b>CPC Combination Sets - Searched*</b>		
<b>Symbol</b>	<b>Date</b>	<b>Examiner</b>

<b>US Classification - Searched*</b>			
<b>Class</b>	<b>Subclass</b>	<b>Date</b>	<b>Examiner</b>

\* See search history printout included with this form or the SEARCH NOTES box below to determine the scope of the search.

<b>Search Notes</b>		
<b>Search Notes</b>	<b>Date</b>	<b>Examiner</b>
Performed double patenting search in EAST	6/21/2017	gmckie
Performed initial prior art search in EAST	6/21/2017	gmckie
Updated prior art search in EAST	1/19/2018	gmckie
Updated prior art search in EAST	9/17/2018	gmckie

<b>Interference Search</b>			
<b>US Class/CPC Symbol</b>	<b>US Subclass/CPC Group</b>	<b>Date</b>	<b>Examiner</b>
	SEE SEARCH HISTORY	05/13/2019	gmckie

	/GINA MCKIE/ Examiner.Art Unit 2631
--	-------------------------------------



## EAST Search History

## EAST Search History (Prior Art)

Ref #	Hits	Search Query	DBs	Default Operator	Plurals	Time Stamp
S1	1165	375/365.CCLS.	US-PGPUB; USPAT; USOCR; FPRS; EPO; JPO; DERWENT; IBM_TDB	OR	OFF	2017/06/22 11:46
S2	2	"20020158801"	US-PGPUB; USPAT; USOCR; FPRS; EPO; JPO; DERWENT; IBM_TDB	OR	OFF	2018/09/17 09:12
S3	88	("2002/0158801").URPN.	USPAT	OR	ON	2018/09/17 10:25
S4	994	"directed wireless communication"	USPAT	OR	ON	2018/09/17 11:02
S5	2396	"directed wireless communication"	US-PGPUB; USPAT; USOCR; FPRS; EPO; JPO; DERWENT; IBM_TDB	OR	ON	2018/09/17 11:04
S6	26	"directed wireless communication" AND multi-beam	US-PGPUB; USPAT; USOCR; FPRS; EPO; JPO; DERWENT; IBM_TDB	OR	ON	2018/09/17 11:04
S7	51	multi-beam WITH directed WITH communication	US-PGPUB; USPAT; USOCR; FPRS; EPO; JPO; DERWENT; IBM_TDB	OR	ON	2018/09/17 11:08
S8	349	multi-beam AND Wi-Fi	US-PGPUB; USPAT; USOCR; FPRS; EPO; JPO; DERWENT; IBM_TDB	OR	ON	2018/09/17 11:15
S9	327	multi-beam AND Wi-Fi AND array	US-PGPUB; USPAT; USOCR; FPRS; EPO; JPO; DERWENT; IBM_TDB	OR	ON	2018/09/17 11:25
S10	9134	multi-beam AND array	US-PGPUB; USPAT; USOCR; FPRS; EPO; JPO; DERWENT; IBM_TDB	OR	ON	2018/09/17 11:29
S11	585	multi-beam AND array AND "access point"	US-PGPUB; USPAT; USOCR; FPRS; EPO; JPO; DERWENT; IBM_TDB	OR	ON	2018/09/17 11:32
S12	2050	multi-beam AND array AND directional	US-PGPUB; USPAT; USOCR; FPRS; EPO; JPO; DERWENT; IBM_TDB	OR	ON	2018/09/17 11:32
S13	0	S11 AND @ad<"2003"	US-PGPUB; USPAT; USOCR; FPRS; EPO; JPO; DERWENT; IBM_TDB	OR	ON	2018/09/17 11:35

EAST Search History

S14	16	S11 AND @ad< "20030101"	US-PGPUB; USPAT; USOCR; FPRS; EPO; JPO; DERWENT; IBM_TDB	OR	ON	2018/09/17 11:35
S15	312593	first ADJ signal	US-PGPUB; USPAT; USOCR; FPRS; EPO; JPO; DERWENT; IBM_TDB	OR	ON	2018/09/17 11:42
S16	309870	second ADJ signal	US-PGPUB; USPAT; USOCR; FPRS; EPO; JPO; DERWENT; IBM_TDB	OR	ON	2018/09/17 11:43
S17	38189	remote ADJ station	US-PGPUB; USPAT; USOCR; FPRS; EPO; JPO; DERWENT; IBM_TDB	OR	ON	2018/09/17 11:43
S18	112197	set NEAR2 weight\$3	US-PGPUB; USPAT; USOCR; FPRS; EPO; JPO; DERWENT; IBM_TDB	OR	ON	2018/09/17 11:45
S19	109	S15 AND S16 AND S17 AND S18	US-PGPUB; USPAT; USOCR; FPRS; EPO; JPO; DERWENT; IBM_TDB	OR	ON	2018/09/17 11:46
S20	4361	"first signal" WITH "second signal" WITH simultaneous\$3	US-PGPUB; USPAT; USOCR; FPRS; EPO; JPO; DERWENT; IBM_TDB	OR	ON	2018/09/17 11:54
S21	34	S18 AND S20	US-PGPUB; USPAT; USOCR; FPRS; EPO; JPO; DERWENT; IBM_TDB	OR	ON	2018/09/17 12:03
S22	14	S20 AND "multi-beam"	US-PGPUB; USPAT; USOCR; FPRS; EPO; JPO; DERWENT; IBM_TDB	OR	ON	2018/09/17 12:04
S23	436	S12 AND @ad< "20030101"	US-PGPUB; USPAT; USOCR; FPRS; EPO; JPO; DERWENT; IBM_TDB	OR	ON	2018/09/17 12:08
S24	43	S23 AND ("first signal") AND "second signal"	US-PGPUB; USPAT; USOCR; FPRS; EPO; JPO; DERWENT; IBM_TDB	OR	ON	2018/09/17 12:11

**EAST Search History (Interference)**

Ref #	Hits	Search Query	DBs	Default Operator	Plurals	Time Stamp
S25	21	"6714584"	US-PGPUB; USPAT	OR	ON	2019/05/13 09:51
S26	1	"6714584".PN.	US-PGPUB; USPAT	OR	ON	2019/05/13 09:51
S27	1852	(simultaneous\$3 WITH antenna WITH (first AND second)).CLM.	US-PGPUB; USPAT	OR	ON	2019/05/13 10:29

EAST Search History

S28	36	(simultaneous\$3 WITH antenna WITH (first AND second) WITH remote).CLM.	US- PGPUB; USPAT	OR	ON	2019/05/13 10:33
-----	----	--	------------------------	----	----	---------------------

**6/ 28/ 2019 11:11:54 AM**

**C:\ Users\ gmckie\ Documents\ EAST\ Workspaces\ 15495539.w sp**

Serial No.: 15/495,539  
Attorney Docket No.: 1640-001.203

**IN THE UNITED STATES PATENT AND TRADEMARK OFFICE**

Applicant	: Marcus DaSilva
Serial No.	: 15/495,539
Filed	: April 24, 2017
For	: DIRECTED WIRELESS COMMUNICATION
Examiner	: McKie, Gina M
Art Unit	: 2631
Confirmation No.	: 1050

**OFFICE ACTION RESPONSE**

Commissioner for Patents  
P.O. Box 1450  
Alexandria, VA 22313-1450

Commissioner:

In response to the Office action transmitted September 26, 2018, please reconsider the above-captioned application in light of the following amendments and remarks.

**Amendments to the Claims** are set forth in the listing of the claims beginning on page 2 of this paper; and

**Remarks/Arguments** begin on page 7 of this paper.



## Electronic Patent Application Fee Transmittal

<b>Application Number:</b>	15495539				
<b>Filing Date:</b>	24-Apr-2017				
<b>Title of Invention:</b>	DIRECTED WIRELESS COMMUNICATION				
<b>First Named Inventor/Applicant Name:</b>	Marcus Da Silva				
<b>Filer:</b>	Glen L. Nuttall				
<b>Attorney Docket Number:</b>	1640-001.203				
Filed as Small Entity					
<b>Filing Fees for Utility under 35 USC 111(a)</b>					
<b>Description</b>	<b>Fee Code</b>	<b>Quantity</b>	<b>Amount</b>	<b>Sub-Total in USD(\$)</b>	
<b>Basic Filing:</b>					
<b>Pages:</b>					
<b>Claims:</b>					
INDEPENDENT CLAIMS IN EXCESS OF 3	2201	1	230	230	
<b>Miscellaneous-Filing:</b>					
<b>Petition:</b>					
<b>Patent-Appeals-and-Interference:</b>					
<b>Post-Allowance-and-Post-Issuance:</b>					

Description	Fee Code	Quantity	Amount	Sub-Total in USD(\$)
<b>Extension-of-Time:</b>				
Extension - 3 months with \$0 paid	2253	1	700	700
<b>Miscellaneous:</b>				
<b>Total in USD (\$)</b>				<b>930</b>

## Electronic Acknowledgement Receipt

<b>EFS ID:</b>	35538790
<b>Application Number:</b>	15495539
<b>International Application Number:</b>	
<b>Confirmation Number:</b>	1050
<b>Title of Invention:</b>	DIRECTED WIRELESS COMMUNICATION
<b>First Named Inventor/Applicant Name:</b>	Marcus Da Silva
<b>Customer Number:</b>	22145
<b>Filer:</b>	Glen L. Nuttall
<b>Filer Authorized By:</b>	
<b>Attorney Docket Number:</b>	1640-001.203
<b>Receipt Date:</b>	27-MAR-2019
<b>Filing Date:</b>	24-APR-2017
<b>Time Stamp:</b>	02:46:16
<b>Application Type:</b>	Utility under 35 USC 111(a)

### Payment information:

Submitted with Payment	yes
Payment Type	CARD
Payment was successfully received in RAM	\$930
RAM confirmation Number	032719INTEFSW02482500
Deposit Account	
Authorized User	

The Director of the USPTO is hereby authorized to charge indicated fees and credit any overpayment as follows:

<b>File Listing:</b>					
<b>Document Number</b>	<b>Document Description</b>	<b>File Name</b>	<b>File Size(Bytes)/ Message Digest</b>	<b>Multi Part /.zip</b>	<b>Pages (if appl.)</b>
1		doc11784320190326235436.pdf	435137  2520b6c38578251b31774c7ede7563664796c402	yes	9
<b>Multipart Description/PDF files in .zip description</b>					
		<b>Document Description</b>	<b>Start</b>	<b>End</b>	
		Miscellaneous Incoming Letter	9	9	
		Applicant Arguments/Remarks Made in an Amendment	7	8	
		Claims	2	6	
		Amendment/Req. Reconsideration-After Non-Final Reject	1	1	
<b>Warnings:</b>					
The page size in the PDF is too large. The pages should be 8.5 x 11 or A4. If this PDF is submitted, the pages will be resized upon entry into the Image File Wrapper and may affect subsequent processing					
<b>Information:</b>					
2	Fee Worksheet (SB06)	fee-info.pdf	32244  704597a5fb97ef6ba11e1e2bd9730d12d29663ee	no	2
<b>Warnings:</b>					
<b>Information:</b>					
<b>Total Files Size (in bytes):</b>			467381		

**This Acknowledgement Receipt evidences receipt on the noted date by the USPTO of the indicated documents, characterized by the applicant, and including page counts, where applicable. It serves as evidence of receipt similar to a Post Card, as described in MPEP 503.**

**New Applications Under 35 U.S.C. 111**

**If a new application is being filed and the application includes the necessary components for a filing date (see 37 CFR 1.53(b)-(d) and MPEP 506), a Filing Receipt (37 CFR 1.54) will be issued in due course and the date shown on this Acknowledgement Receipt will establish the filing date of the application.**

**National Stage of an International Application under 35 U.S.C. 371**

**If a timely submission to enter the national stage of an international application is compliant with the conditions of 35 U.S.C. 371 and other applicable requirements a Form PCT/DO/EO/903 indicating acceptance of the application as a national stage submission under 35 U.S.C. 371 will be issued in addition to the Filing Receipt, in due course.**

**New International Application Filed with the USPTO as a Receiving Office**

**If a new international application is being filed and the international application includes the necessary components for an international filing date (see PCT Article 11 and MPEP 1810), a Notification of the International Application Number and of the International Filing Date (Form PCT/RO/105) will be issued in due course, subject to prescriptions concerning national security, and the date shown on this Acknowledgement Receipt will establish the international filing date of the application.**

IN THE UNITED STATES PATENT AND TRADEMARK OFFICE

Applicants: Marcus Da Silva et al.  
Title: DIRECTED WIRELESS COMMUNICATION  
Serial No.: 15/495,539 Filed: April 24, 2017  
Examiner: McKie, Gina M. Group Art Unit: 2631  
Attorney Docket No.: 1640-001.203 Confirmation No.: 1050

---

**CERTIFICATE OF EFS-WEB TRANSMISSION  
UNDER 37 CFR § 1.8**

I hereby certify that the enclosed Office Action Response (8 pages); and Payment by Credit Card are being transmitted to the United States Patent and Trademark Office **from the Pacific Time Zone** via EFS-Web on March 26, 2019.

Date: March 26, 2019

/Glen L. Nuttall/

Glen L. Nuttall

Mailing Address:

**KLEIN, O'NEILL & SINGH, LLP (Customer No.: 22145)**  
16755 Von Karman Avenue, Suite 275  
Irvine, California 92606  
Tel: 949-955-1920  
Fax: 949-955-1921

## **REMARKS**

By this paper Claims 2-7, 10-17 and 19 have been amended, and Claims 1, 9 and 20 have been cancelled without prejudice. Applicant reserves the right to pursue the subject matter of the cancelled claims in the future. As such, Claims 2-8 and 10-19 are currently pending for consideration in this application.

### Objected-to Claims Rewritten Into Independent Form

The Office Action objected to Claims 2, 5-8, 11, 13-16 and 18-20, but indicated that these claims would be allowable if rewritten into independent form. As such, Claims 2 and 7 have been amended into independent form, incorporating all of the limitations of previous independent Claim 1, which has been cancelled. Claim 11 has also been amended into independent form, incorporating all of the limitations of previous independent Claim 9, which has been cancelled. Lastly, independent Claim 17 has been amended to incorporate all of the limitations of dependent Claim 20, which has been cancelled.

As all of the above-discussed amendments comprise rewriting objected-to claims into independent form, Applicants submit that the pending claims are currently in condition for allowance.

### Rejections Under 35 USC 103

The Office Action rejected several claims as unpatentable over Chen (US2002/0137538) in view of Ishii (US 6,714,584). In the interest of simplifying prosecution, Applicant has amended other, objected-to claims into allowable independent forms. Thus, these rejections are moot. Nevertheless, Applicant traverses the rejection, and reserves the right to present claims directed to the same or similar subject matter in the future.

### Conclusion

For the foregoing reasons, it is respectfully submitted that the rejections set forth in the outstanding Office action are inapplicable to the current claims. Accordingly, issuance of a Notice of Allowance is requested.

Serial No.: 15/495,539  
Attorney Docket No.: 1640-001.203

Please charge any additional fees, including any fees for additional extension of time, or credit overpayment to Deposit Account No. 11-1159.

Respectfully submitted,

Klein, O'Neill & Singh, LLP

Dated: March 25, 2019

By /Glen L Nuttall/

Glen L Nuttall, Reg. No. 46,188

Telephone: (949) 955-1920

Klein, O'Neill & Singh, LLP  
16755 Von Karman, Suite 275  
Irvine, CA 92606  
T (949) 955-1920  
F (949) 955-1921



## **AMENDMENTS TO THE CLAIMS**

Please amend the claims to read as follows. Additions are underlined. Deletions are in ~~strikeout~~ text or ~~[[double brackets]]~~.

1. (Cancelled)

2. (Currently Amended) ~~The receiver as recited in Claim 1,~~ A receiver for use in a wireless communications system, the receiver comprising:

an antenna, wherein the antenna comprises a first antenna element and a second antenna element; ~~and~~

a transceiver operatively coupled to the antenna and configured to transmit and receive electromagnetic signals using the antenna; and

a processor operatively coupled to the transceiver, the processor configured to:

~~wherein the processor is further configured to:~~

receive ~~the a~~ first signal transmission from ~~the a~~ remote station via the first antenna element and ~~the a~~ second signal transmission from the remote station via the second antenna element simultaneously; ~~and~~

determine first signal information for the first signal transmission;

determine second signal information for the second signal transmission,

wherein the second signal information is different than the first signal information;

determine a set of weighting values based on the first signal information and the second signal information, wherein the set of weighting values is configured to be used by the remote station to construct one or more beam-formed transmission signals;

cause the transceiver to transmit ~~the a~~ third signal to the remote station via the antenna, the third signal comprising content based on the set of weighting values.

3. (Currently Amended) ~~The receiver as recited in Claim 1,~~ wherein the first signal transmission and the second signal transmission comprise electromagnetic signals comprising one or more transmission peaks and one or more transmission nulls.

4. (Currently Amended) The receiver as recited in Claim ~~1~~ 3, wherein the first signal transmission and the second signal transmission are directional transmissions.

5. (Currently Amended) The receiver as recited in Claim ~~1~~ 6, wherein the set of weighting values ~~is~~ is further based on one or more of: a transmit power level, a data transmit rate, an antenna direction, quality of service data, or timing data.

6. (Currently Amended) The receiver as recited in Claim ~~1~~ 2, wherein the content comprises data configured to be used by the remote station to modify the placement of one or more transmission peaks and one or more transmission nulls in a subsequent signal transmission.

7. (Currently Amended) ~~The receiver as recited in Claim 1, wherein the processor is further configured to~~ A receiver for use in a wireless communications system, the receiver comprising:

an antenna;

a transceiver operatively coupled to the antenna and configured to transmit and receive electromagnetic signals using the antenna; and

a processor operatively coupled to the transceiver, the processor configured to:

receive a first signal transmission from a remote station via the antenna and a

second signal transmission from the remote station via the antenna simultaneously;

determine first signal information for the first signal transmission;

determine second signal information for the second signal transmission,

wherein the second signal information is different than the first signal information;

determine a set of weighting values based on the first signal information and the second signal information, wherein the set of weighting values is configured to be

used by the remote station to construct one or more beam-formed transmission

signals;

cause the transceiver to generate a third signal comprising content based on the set of weighting values;

determine a plurality of signal strength indications for the first signal

transmission;

determine a first signal strength average based on the plurality of signal strength indications for the first signal transmission;

determine a plurality of signal strength indications for the second signal transmission;

determine a second signal strength average based on the plurality of signal strength indications for the second signal transmission; and

cause the transceiver to generate a fourth signal based on the first signal strength average and the second signal strength average.

8. (Previously Presented) The receiver as recited in Claim 7, wherein the processor is further configured to: cause the transceiver to transmit the fourth signal to the remote station via the antenna.

9. (Cancelled)

10. (Currently Amended) The method as recited in Claim ~~9~~ 11, further comprising: transmitting the third signal to the remote station via the antenna.

11. (Currently Amended) ~~The method as recited in Claim 9~~ A method in a wireless communications system, the method comprising:

receiving a first signal transmission from a remote station via a first antenna element of an antenna and a second signal transmission from the remote station via a second antenna element of the antenna simultaneously, wherein the first signal transmission and the second signal transmission comprise electromagnetic signals comprising one or more transmission peaks and one or more transmission nulls;

determining first signal information for the first signal transmission;

determining second signal information for the second signal transmission, wherein the second signal information is different than the first signal information;

determining a set of weighting values based on the first signal information and the second signal information, wherein the set of weighting values is configured to be used by the

remote station to construct one or more beam-formed transmission signals; and  
transmitting to the remote station a third signal comprising content based on the set of  
weighting values.

12. (Currently Amended) The method as recited in Claim-9 11, wherein the first signal transmission and the second signal transmission are directional transmissions.

13. (Currently Amended) The method as recited in Claim-9 11, wherein the set of weighting values is further based on one or more of: a transmit power level, a data transmit rate, an antenna direction, quality of service data, or timing data.

14. (Currently Amended) The method as recited in Claim-9 13, wherein the content comprises data configured to be used by the remote station to modify the placement of one or more transmission peaks and one or more transmission nulls in a subsequent signal transmission.

15. (Currently Amended) The method as recited in Claim-9 14, further comprising:  
determining a plurality of signal strength indications for the first signal transmission;  
determining a first signal strength average based on the plurality of signal strength indications for the first signal transmission;

determining a plurality of signal strength indications for the second signal transmission;

determining a second signal strength average based on the plurality of signal strength indications for the second signal transmission; and

generating a fourth signal based on the first signal strength average and the second signal strength average.

16. (Previously Presented) The method as recited in Claim 15, further comprising:  
causing the transceiver to transmit the fourth signal to the remote station via the antenna.

17. (Currently Amended) An apparatus for use in a wireless communications system, the apparatus comprising:

an antenna;

a transceiver operatively coupled to the antenna; and  
a processor operatively coupled to the transceiver, the processor configured to:  
receive a first signal transmission from a remote station via the antenna,  
the first signal transmission comprising first signal information, wherein the first signal information comprises one or more of: a transmit power level, a data transmit rate, an antenna direction, quality of service data, or timing data;

receive a second signal transmission from the remote station via the antenna, the second signal transmission comprising second signal information;  
determine a set of weighting values based on the first signal information and the second signal information, wherein the set of weighting values is configured to be used by the remote station to construct one or more beam-formed transmission signals;  
cause the transceiver to generate a third signal comprising content based on the set of weighting values.

18. (Previously Presented) The apparatus as recited in Claim 17, wherein the first signal transmission and the second signal transmission comprise electromagnetic signals comprising one or more transmission peaks and one or more transmission nulls.

19. (Currently Amended) The apparatus as recited in Claim ~~17~~ 18, wherein the first signal information comprises one or more of: a transmit power level, a data transmit rate, an antenna direction, quality of service data, or timing data.

20. (Cancelled)

<b>PATENT APPLICATION FEE DETERMINATION RECORD</b> Substitute for Form PTO-875	Application or Docket Number 15/495,539	Filing Date 04/24/2017	<input type="checkbox"/> To be Mailed
---	--	---------------------------	---------------------------------------

ENTITY:    LARGE    SMALL    MICRO

**APPLICATION AS FILED - PART I**

FOR	(Column 1) NUMBER FILED	(Column 2) NUMBER EXTRA	RATE (\$)	FEE (\$)
<input type="checkbox"/> BASIC FEE (37 CFR 1.16(a), (b), or (c))	N/A	N/A	N/A	
<input type="checkbox"/> SEARCH FEE (37 CFR 1.16(k), (l), or (m))	N/A	N/A	N/A	
<input type="checkbox"/> EXAMINATION FEE (37 CFR 1.16(o), (p), or (q))	N/A	N/A	N/A	
TOTAL CLAIMS (37 CFR 1.16(j))	minus 20 = *		x \$40 =	
INDEPENDENT CLAIMS (37 CFR 1.16(h))	minus 3 = *		x \$210 =	
<input type="checkbox"/> APPLICATION SIZE FEE (37 CFR 1.16(s))	If the specification and drawings exceed 100 sheets of paper, the application size fee due is \$310 (\$155 for small entity) for each additional 50 sheets or fraction thereof. See 35 U.S.C. 41(a)(1)(G) and 37 CFR 1.16(s).			
<input type="checkbox"/> MULTIPLE DEPENDENT CLAIM PRESENT (37 CFR 1.16(j))				
* If the difference in column 1 is less than zero, enter "0" in column 2.			TOTAL	

**APPLICATION AS AMENDED - PART II**

	(Column 1)		(Column 2)	(Column 3)	RATE (\$)	ADDITIONAL FEE (\$)	
<b>AMENDMENT</b>	03/27/2019		CLAIMS REMAINING AFTER AMENDMENT	HIGHEST NUMBER PREVIOUSLY PAID FOR	PRESENT EXTRA		
	Total (37 CFR 1.16(i))	* 17	Minus	** 20	= 0	x \$ 50 = 0	
	Independent (37 CFR 1.16(h))	* 4	Minus	*** 3	= 1	x \$ 230 = 230	
	<input type="checkbox"/> Application Size Fee (37 CFR 1.16(s))						
<input type="checkbox"/> FIRST PRESENTATION OF MULTIPLE DEPENDENT CLAIM (37 CFR 1.16(j))						TOTAL ADD'L FEE	230

	(Column 1)		(Column 2)	(Column 3)	RATE (\$)	ADDITIONAL FEE (\$)	
<b>AMENDMENT</b>			CLAIMS REMAINING AFTER AMENDMENT	HIGHEST NUMBER PREVIOUSLY PAID FOR	PRESENT EXTRA		
	Total (37 CFR 1.16(i))	*	Minus	**	=	x \$ 0 =	
	Independent (37 CFR 1.16(h))	*	Minus	***	=	x \$ 0 =	
	<input type="checkbox"/> Application Size Fee (37 CFR 1.16(s))						
<input type="checkbox"/> FIRST PRESENTATION OF MULTIPLE DEPENDENT CLAIM (37 CFR 1.16(j))						TOTAL ADD'L FEE	

\* If the entry in column 1 is less than the entry in column 2, write "0" in column 3.

\*\* If the "Highest Number Previously Paid For" IN THIS SPACE is less than 20, enter "20".

\*\*\* If the "Highest Number Previously Paid For" IN THIS SPACE is less than 3, enter "3".

The "Highest Number Previously Paid For" (Total or Independent) is the highest number found in the appropriate box in column 1.

This collection of information is required by 37 CFR 1.16. The information is required to obtain or retain a benefit by the public which is to file (and by the USPTO to process) an application. Confidentiality is governed by 35 U.S.C. 122 and 37 CFR 1.14. This collection is estimated to take 12 minutes to complete, including gathering, preparing, and submitting the completed application form to the USPTO. Time will vary depending upon the individual case. Any comments on the amount of time you require to complete this form and/or suggestions for reducing this burden, should be sent to the Chief Information Officer, U.S. Patent and Trademark Office, U.S. Department of Commerce, P.O. Box 1450, Alexandria, VA 22313-1450. DO NOT SEND FEES OR COMPLETED FORMS TO THIS ADDRESS. **SEND TO: Commissioner for Patents, P.O. Box 1450, Alexandria, VA 22313-1450.**

*If you need assistance in completing the form, call 1-800-PTO-9199 and select option 2.*



UNITED STATES PATENT AND TRADEMARK OFFICE

UNITED STATES DEPARTMENT OF COMMERCE  
United States Patent and Trademark Office  
Address: COMMISSIONER FOR PATENTS  
P. O. Box 1450  
Alexandria, Virginia 22313-1450  
www.uspto.gov

APPLICATION NO.	FILING DATE	FIRST NAMED INVENTOR	ATTORNEY DOCKET NO.	CONFIRMATION NO.
15/495,539	04/24/2017	Marcus Da Silva	1640-001.203	1050

22145 7590 09/26/2018  
KLEIN, O'NEILL & SINGH, LLP  
16755 VON KARMAN AVENUE  
SUITE 275  
IRVINE, CA 92606

EXAMINER
----------

MCKIE, GINA M

ART UNIT	PAPER NUMBER
----------	--------------

2631

NOTIFICATION DATE	DELIVERY MODE
-------------------	---------------

09/26/2018

ELECTRONIC

**Please find below and/or attached an Office communication concerning this application or proceeding.**

The time period for reply, if any, is set in the attached communication.

Notice of the Office communication was sent electronically on above-indicated "Notification Date" to the following e-mail address(es):

KOS\_Docketing@koslaw.com





## **DETAILED ACTION**

### ***Notice of Pre-AIA or AIA Status***

1. The present application is being examined under the pre-AIA first to invent provisions.

### ***Continued Examination Under 37 CFR 1.114***

2. A request for continued examination under 37 CFR 1.114, including the fee set forth in 37 CFR 1.17(e), was filed in this application after final rejection. Since this application is eligible for continued examination under 37 CFR 1.114, and the fee set forth in 37 CFR 1.17(e) has been timely paid, the finality of the previous Office action has been withdrawn pursuant to 37 CFR 1.114. Applicant's submission filed on August 01, 2018 has been entered.

### ***Response to Amendment***

3. Acknowledgement is made of the amendment filed August 01, 2018. Claims 1-20 remain pending in the application.

- No claims are currently amended.
- No claims have been canceled.
- No claims are new.

***Response to Arguments***

4. Applicant's arguments filed October 05, 2017 with respect to the rejection of claims 1-20 is/are rejected under pre-AIA 35 U.S.C. 103(a) as being unpatentable over Crilly, Jr. et al. (US 2002/0158801 A1) in view of Ishii et al. (US 6,714,584) have been fully considered and are persuasive. Therefore, the rejection has been withdrawn. However, upon further consideration, a new ground(s) of rejection is made in view of Chen et al. (US 2002/0137538 A1).

***Claim Rejections - 35 USC § 103***

5. The following is a quotation of pre-AIA 35 U.S.C. 103(a) which forms the basis for all obviousness rejections set forth in this Office action:

(a) A patent may not be obtained though the invention is not identically disclosed or described as set forth in section 102, if the differences between the subject matter sought to be patented and the prior art are such that the subject matter as a whole would have been obvious at the time the invention was made to a person having ordinary skill in the art to which said subject matter pertains. Patentability shall not be negated by the manner in which the invention was made.

6. The factual inquiries set forth in *Graham v. John Deere Co.*, 383 U.S. 1, 148 USPQ 459 (1966), that are applied for establishing a background for determining obviousness under pre-AIA 35 U.S.C. 103(a) are summarized as follows:

1. Determining the scope and contents of the prior art.
2. Ascertaining the differences between the prior art and the claims at issue.
3. Resolving the level of ordinary skill in the pertinent art.

4. Considering objective evidence present in the application indicating obviousness or nonobviousness.

7. Claims 1, 3, 4, 9, 10, 12 and 17 is/are rejected under pre-AIA 35 U.S.C. 103(a) as being unpatentable over Chen et al. (US 2002/0137538 A1) in view of Ishii et al. (US 6,714,584).

**Regarding claim 1,**

As shown in FIGS. 1-5, Chen discloses a receiver for use in a wireless communications system, the receiver comprising:

- an antenna (**see Chen, FIG. 5, antenna array 506**);
- a transceiver operatively coupled to the antenna and configured to transmit and receive electromagnetic signals using the antenna (**see Chen, FIG. 5, tracking channel 502**); and
- a processor operatively coupled to the transceiver, (**see Chen, FIG. 5, tracking channel 502**) the processor configured to:
  - receive a first signal transmission from a remote station via the antenna and a second signal transmission via the antenna (**see Chen FIG. 5, paragraph [0047]; A tracking receiver 518 in the receiving path is coupled to the diplexer 516. Similar to its search receiver 508 counterpart, the tracking receiver 518 amplifies, filters and downconverts the signal from each tracking element 506a to baseband.**);

- determine first signal information for the first signal transmission (**see Chen FIG. 5, paragraph [0042]; By applying different weights to the signals at to, and combining them, a directional search beam can effectively be formed in the digital domain. Specifically, a directional search beam can be formed in one angular direction by applying the following algorithm)**);
- determine second signal information for the second signal transmission, wherein the second signal information is different than the first signal information (**see Chen FIG. 5, paragraph [0042]; By applying different weights to the signals at to, and combining them, a directional search beam can effectively be formed in the digital domain. Specifically, a directional search beam can be formed in one angular direction by applying the following algorithm)**);
- determine a set of weighting values based on the first signal information and the second signal information, wherein the set of weighting values is configured to be used by the remote station to construct one or more beam-formed transmission signals (**see Chen FIG. 5, paragraph [0042]; By applying different weights to the signals at to, and combining them, a directional search beam can effectively be formed in the digital domain. Specifically, a directional search beam can be formed in one angular direction by applying the following algorithm)**); and
- cause the transceiver to generate a third signal comprising content based on the set of weighting values (**see Chen, FIG. 5, paragraph [0053]; A**

**transmitter 530 is coupled to the tracking filter 526. The transmitter 530 upconverts, filters and amplifies the weighted modulated signal. The output of the transmitter 530 is coupled through the diplexer 516 to the tracking antennas 506a where the signal is transmitted into free space with increased gain in the direction defined by the weights applied to the signal by the tracking filter 526.)**

Chen does not specifically disclose “receive a first signal transmission from a remote station via the antenna and a second signal transmission from the remote station via the antenna simultaneously.”

However, Ishii in the same field of endeavor discloses receiving a first signal transmission from a remote station via the antenna and a second signal transmission from the remote station via the antenna simultaneously (**see Ishii, col. 3, lines 9-30; “Signals received at different directional antennas 1-1 to 1-N are introduced into delay circuits 2-2 to 2-M. A directivity in a direction, for example, at every equal angle (360/N degrees) is assigned to each of antennas 1-1 to 1-N, respectively. Delay circuit 2-1 has a time delay of 0 and thus is omitted in the drawings. Delay circuits 2-2 to 2-M adaptively delay the received signals so that receivers 3-1 to 3-M may receive simultaneously the desired signal components incoming at different timings.”**).

It would have been obvious to one of ordinary skill in the art at the time the present invention was made to modify the invention of Chen as taught by Ishii and

receive a first signal transmission from a remote station via the antenna and a second signal transmission from the remote station via the antenna simultaneously.

***Rationale: Applying a known technique to a known device (method, or product) ready for improvement to yield predictable results***

To reject a claim based on this rationale, Office personnel must resolve the Graham factual inquiries. Then, Office personnel must articulate the following:

(1) a finding that the prior art contained a “base” device (method, or product) upon which the claimed invention can be seen as an “improvement;”

(2) a finding that the prior art contained a known technique that is applicable to the base device (method, or product);

(3) a finding that one of ordinary skill in the art would have recognized that applying the known technique would have yielded predictable results and resulted in an improved system; and

(4) whatever additional findings based on the Graham factual inquiries may be necessary, in view of the facts of the case under consideration, to explain a conclusion of obviousness. (MPEP § 2143).

In this case:

Chen contains a “base” device of a receiver for use in a wireless communications system which the claimed invention can be seen as an “improvement” in that receiving a

first signal transmission from a remote station via the antenna and a second signal transmission from the remote station via the antenna simultaneously.

Ishii contains known technique of a first signal transmission from a remote station via the antenna and a second signal transmission from the remote station via the antenna simultaneously that is applicable to the "base" device.

Ishii's known technique a first signal transmission from a remote station via the antenna and a second signal transmission from the remote station via the antenna simultaneously would have been recognized by one of ordinary skill in the art as applicable to the "base" process of Chen and the results would have been predictable and resulted in a receiver for use in a wireless communications system receiving a first signal transmission from a remote station via the antenna and a second signal transmission from the remote station via the antenna simultaneously which results in an improved process.

Therefore, the claimed subject matter would have been obvious to a person having ordinary skill in the art at the time the invention was made.

**Regarding claim 3,**

The combination of Chen and Ishii discloses the receiver as recited in Claim 1, wherein the first signal transmission and the second signal transmission comprise electromagnetic signals comprising one or more transmission peaks and one or more transmission nulls (**see Chen FIG. 4, paragraph [0035]; "This concept is illustrated in FIG. 4 where an exemplary CDMA cellular system is shown during soft handoff.**

**In the exemplary CDMA cellular system, a base station 402 includes a directional antenna such as an antenna array 404 made up of spatially separated individual radiating elements.”).**

**Regarding claim 4,**

The combination of Crilly and Ishii discloses the receiver as recited in Claim 1, wherein the first signal transmission and the second signal transmission are directional transmissions (see Chen FIG. 4, paragraph [0035]; “This concept is illustrated in FIG. 4 where an exemplary CDMA cellular system is shown during soft handoff. In the exemplary CDMA cellular system, a base station 402 includes a directional antenna such as an antenna array 404 made up of spatially separated individual radiating elements.”).

**Regarding claim 9,**

As shown in FIGS. 1-24, Crilly discloses a method in a wireless communications system, the method comprising:

- receiving a first signal transmission from a remote station via a first antenna element of an antenna and a second signal transmission via a second antenna element of the antenna (see Chen, FIG. 5, antenna array 506);
- determining first signal information for the first signal transmission (see Chen FIG. 5, paragraph [0042]; **By applying different weights to the signals at to, and**



**combining them, a directional search beam can effectively be formed in the digital domain. Specifically, a directional search beam can be formed in one angular direction by applying the following algorithm);**

- determining second signal information for the second signal transmission, wherein the second signal information is different than the first signal information (**see Chen FIG. 5, paragraph [0042]; By applying different weights to the signals at to, and combining them, a directional search beam can effectively be formed in the digital domain. Specifically, a directional search beam can be formed in one angular direction by applying the following algorithm);**
- determining a set of weighting values based on the first signal information and the second signal information, wherein the set of weighting values is configured to be used by the remote station to construct one or more beam-formed transmission signals (**see Chen FIG. 5, paragraph [0042]; By applying different weights to the signals at to, and combining them, a directional search beam can effectively be formed in the digital domain. Specifically, a directional search beam can be formed in one angular direction by applying the following algorithm);** and
- transmitting to the remote station a third signal comprising content based on the set of weighting values (**see Chen, FIG. 5, paragraph [0053]; A transmitter 530 is coupled to the tracking filter 526. The transmitter 530 upconverts, filters and amplifies the weighted modulated signal. The output of the transmitter 530 is coupled through the diplexer 516 to the tracking antennas 506a where the**

**signal is transmitted into free space with increased gain in the direction defined by the weights applied to the signal by the tracking filter 526.).**

Chen does not specifically disclose “receive a first signal transmission from a remote station via the antenna and a second signal transmission from the remote station via the antenna simultaneously.”

However, Ishii in the same field of endeavor discloses receiving a first signal transmission from a remote station via the antenna and a second signal transmission from the remote station via the antenna simultaneously (see Ishii, col. 3, lines 9-30; **“Signals received at different directional antennas 1-1 to 1-N are introduced into delay circuits 2-2 to 2-M. A directivity in a direction, for example, at every equal angle ( $360/N$  degrees) is assigned to each of antennas 1-1 to 1-N, respectively. Delay circuit 2-1 has a time delay of 0 and thus is omitted in the drawings. Delay circuits 2-2 to 2-M adaptively delay the received signals so that receivers 3-1 to 3-M may receive simultaneously the desired signal components incoming at different timings.”**).

It would have been obvious to one of ordinary skill in the art at the time the present invention was made to modify the invention of Chen as taught by Ishii and receive a first signal transmission from a remote station via the antenna and a second signal transmission from the remote station via the antenna simultaneously.

***Rationale: Applying a known technique to a known device (method, or product) ready for improvement to yield predictable results***

To reject a claim based on this rationale, Office personnel must resolve the Graham factual inquiries. Then, Office personnel must articulate the following:

(1) a finding that the prior art contained a “base” device (method, or product) upon which the claimed invention can be seen as an “improvement;”

(2) a finding that the prior art contained a known technique that is applicable to the base device (method, or product);

(3) a finding that one of ordinary skill in the art would have recognized that applying the known technique would have yielded predictable results and resulted in an improved system; and

(4) whatever additional findings based on the Graham factual inquiries may be necessary, in view of the facts of the case under consideration, to explain a conclusion of obviousness. (MPEP § 2143).

In this case:

Chen contains a “base” device of a receiver for use in a wireless communications system which the claimed invention can be seen as an “improvement” in that receiving a first signal transmission from a remote station via the antenna and a second signal transmission from the remote station via the antenna simultaneously.

Ishii contains known technique of a first signal transmission from a remote station via the antenna and a second signal transmission from the remote station via the antenna simultaneously that is applicable to the "base" device.

Ishii's known technique a first signal transmission from a remote station via the antenna and a second signal transmission from the remote station via the antenna simultaneously would have been recognized by one of ordinary skill in the art as applicable to the "base" process of Chen and the results would have been predictable and resulted in a receiver for use in a wireless communications system receiving a first signal transmission from a remote station via the antenna and a second signal transmission from the remote station via the antenna simultaneously which results in an improved process.

Therefore, the claimed subject matter would have been obvious to a person having ordinary skill in the art at the time the invention was made.

**Regarding claim 10,**

The combination of Chen and Ishii discloses the method as recited in Claim 9, further comprising: transmitting the third signal to the remote station via the antenna **(see Chen FIG. 4, paragraph [0035]; "This concept is illustrated in FIG. 4 where an exemplary CDMA cellular system is shown during soft handoff. In the exemplary CDMA cellular system, a base station 402 includes a directional antenna such as an antenna array 404 made up of spatially separated individual radiating elements.").**

**Regarding claim 12,**

The combination of Chen and Ishii discloses the method as recited in Claim 9, wherein the first signal transmission and the second signal transmission are directional transmissions (see Chen FIG. 4, paragraph [0035]; “This concept is illustrated in FIG. 4 where an exemplary CDMA cellular system is shown during soft handoff. In the exemplary CDMA cellular system, a base station 402 includes a directional antenna such as an antenna array 404 made up of spatially separated individual radiating elements.”).

**Regarding claim 17,**

As shown in FIGS. 1-24, Crilly discloses an apparatus for use in a wireless communications system, the apparatus comprising:

- an antenna (see Chen, FIG. 5, antenna array 506);
- a transceiver operatively coupled to the antenna (see Chen, FIG. 5, antenna array 506); and
- a processor operatively coupled to the transceiver (see Chen, FIG. 5, antenna array 506), the processor configured to:

- receive a first signal transmission from a remote station via the antenna, the first signal transmission comprising first signal information (**see Chen FIG. 5, paragraph [0042]; By applying different weights to the signals at to, and combining them, a directional search beam can effectively be formed in the digital domain. Specifically, a directional search beam can be formed in one angular direction by applying the following algorithm**);
- receive a second signal transmission via the antenna, the second signal transmission comprising second signal information (**see Chen FIG. 5, paragraph [0042]; By applying different weights to the signals at to, and combining them, a directional search beam can effectively be formed in the digital domain. Specifically, a directional search beam can be formed in one angular direction by applying the following algorithm**);
- determine a set of weighting values based on the first signal information and the second signal information, wherein the set of weighting values is configured to be used by the remote station to construct one or more beam-formed transmission (**see Chen FIG. 5, paragraph [0042]; By applying different weights to the signals at to, and combining them, a directional search beam can effectively be formed in the digital domain. Specifically, a directional search beam can be formed in one angular direction by applying the following algorithm**);

- cause the transceiver to generate a third signal comprising content based on the set of weighting values (**see Chen, FIG. 5, paragraph [0053]; A transmitter 530 is coupled to the tracking filter 526. The transmitter 530 upconverts, filters and amplifies the weighted modulated signal. The output of the transmitter 530 is coupled through the diplexer 516 to the tracking antennas 506a where the signal is transmitted into free space with increased gain in the direction defined by the weights applied to the signal by the tracking filter 526.**).

Chen does not specifically disclose “receive a first signal transmission from a remote station via the antenna and a second signal transmission from the remote station via the antenna simultaneously.”

However, Ishii in the same field of endeavor discloses receiving a first signal transmission from a remote station via the antenna and a second signal transmission from the remote station via the antenna simultaneously (**see Ishii, col. 3, lines 9-30; “Signals received at different directional antennas 1-1 to 1-N are introduced into delay circuits 2-2 to 2-M. A directivity in a direction, for example, at every equal angle (360/N degrees) is assigned to each of antennas 1-1 to 1-N, respectively. Delay circuit 2-1 has a time delay of 0 and thus is omitted in the drawings. Delay circuits 2-2 to 2-M adaptively delay the received signals so that receivers 3-1 to 3-M may receive simultaneously the desired signal components incoming at different timings.”**).

It would have been obvious to one of ordinary skill in the art at the time the present invention was made to modify the invention of Chen as taught by Ishii and receive a first signal transmission from a remote station via the antenna and a second signal transmission from the remote station via the antenna simultaneously.

***Rationale: Applying a known technique to a known device (method, or product) ready for improvement to yield predictable results***

To reject a claim based on this rationale, Office personnel must resolve the Graham factual inquiries. Then, Office personnel must articulate the following:

- (1) a finding that the prior art contained a “base” device (method, or product) upon which the claimed invention can be seen as an “improvement;”
- (2) a finding that the prior art contained a known technique that is applicable to the base device (method, or product);
- (3) a finding that one of ordinary skill in the art would have recognized that applying the known technique would have yielded predictable results and resulted in an improved system; and
- (4) whatever additional findings based on the Graham factual inquiries may be necessary, in view of the facts of the case under consideration, to explain a conclusion of obviousness. (MPEP § 2143).

In this case:



Chen contains a "base" device of a receiver for use in a wireless communications system which the claimed invention can be seen as an "improvement" in that receiving a first signal transmission from a remote station via the antenna and a second signal transmission from the remote station via the antenna simultaneously.

Ishii contains known technique of a first signal transmission from a remote station via the antenna and a second signal transmission from the remote station via the antenna simultaneously that is applicable to the "base" device.

Ishii's known technique a first signal transmission from a remote station via the antenna and a second signal transmission from the remote station via the antenna simultaneously would have been recognized by one of ordinary skill in the art as applicable to the "base" process of Chen and the results would have been predictable and resulted in a receiver for use in a wireless communications system receiving a first signal transmission from a remote station via the antenna and a second signal transmission from the remote station via the antenna simultaneously which results in an improved process.

Therefore, the claimed subject matter would have been obvious to a person having ordinary skill in the art at the time the invention was made.

***Allowable Subject Matter***

8. Claims 2, 5-8, 11, 13-16, and 18-20 are objected to as being dependent upon a rejected base claim, but would be allowable if rewritten in independent form including all of the limitations of the base claim and any intervening claims.

***Conclusion***

Any inquiry concerning this communication or earlier communications from the examiner should be directed to GINA MCKIE whose telephone number is (571)270-5148. The examiner can normally be reached on Mon-Fri, 8:30 AM-5:00 PM EST.

Examiner interviews are available via telephone, in-person, and video conferencing using a USPTO supplied web-based collaboration tool. To schedule an interview, applicant is encouraged to use the USPTO Automated Interview Request (AIR) at <http://www.uspto.gov/interviewpractice>.

If attempts to reach the examiner by telephone are unsuccessful, the examiner's supervisor, Shuwang Liu can be reached on 571-272-3036. The fax phone number for the organization where this application or proceeding is assigned is 571-273-8300.

Information regarding the status of an application may be obtained from the Patent Application Information Retrieval (PAIR) system. Status information for published applications may be obtained from either Private PAIR or Public PAIR. Status information for unpublished applications is available through Private PAIR only. For more information about the PAIR system, see <http://pair-direct.uspto.gov>. Should you have questions on access to the Private PAIR system, contact the Electronic Business Center (EBC) at 866-217-9197 (toll-free). If you would like assistance from a USPTO Customer Service Representative or access to the automated information system, call 800-786-9199 (IN USA OR CANADA) or 571-272-1000.

/GINA MCKIE/  
Examiner, Art Unit 2631

/CHIEH M FAN/  
Supervisory Patent Examiner, Art Unit 2632

<b>Notice of References Cited</b>	Application/Control No. 15/495,539	Applicant(s)/Patent Under Reexamination DA SILVA ET AL.	
	Examiner GINA MCKIE	Art Unit 2631	Page 1 of 1

**U.S. PATENT DOCUMENTS**

*	Document Number Country Code-Number-Kind Code	Date MM-YYYY	Name	CPC Classification	US Classification
*	A US-2002/0137538 A1	09-2002	Chen, Tao	H04B7/0491	455/575.7
B	US-				
C	US-				
D	US-				
E	US-				
F	US-				
G	US-				
H	US-				
I	US-				
J	US-				
K	US-				
L	US-				
M	US-				


**FOREIGN PATENT DOCUMENTS**

*	Document Number Country Code-Number-Kind Code	Date MM-YYYY	Country	Name	CPC Classification
N					
O					
P					
Q					
R					
S					
T					

**NON-PATENT DOCUMENTS**

*	Include as applicable: Author, Title Date, Publisher, Edition or Volume, Pertinent Pages)
U	
V	
W	
X	

\*A copy of this reference is not being furnished with this Office action. (See MPEP § 707.05(a).)  
Dates in MM-YYYY format are publication dates. Classifications may be US or foreign.

<b>Search Notes</b>  	<b>Application/Control No.</b>  15495539	<b>Applicant(s)/Patent Under Reexamination</b>  DA SILVA ET AL.
	<b>Examiner</b>  GINA MCKIE	<b>Art Unit</b>  2631

CPC- SEARCHED		
Symbol	Date	Examiner
H04L7/042, H04L27/2675 (EAST keyword search)	6/22/2017	gmckie

CPC COMBINATION SETS - SEARCHED		
Symbol	Date	Examiner


US CLASSIFICATION SEARCHED			
Class	Subclass	Date	Examiner

\* See search history printout included with this form or the SEARCH NOTES box below to determine the scope of the search.

SEARCH NOTES		
Search Notes	Date	Examiner
Performed double patenting search in EAST	6/21/2017	gmckie
Performed initial prior art search in EAST	6/21/2017	gmckie
Updated prior art search in EAST	1/19/2018	gmckie
Updated prior art search in EAST	9/17/2018	gmckie

INTERFERENCE SEARCH			
US Class/ CPC Symbol	US Subclass / CPC Group	Date	Examiner

/GINA MCKIE/ Examiner.Art Unit 2631	
--	--

<b><i>Index of Claims</i></b> 	<b>Application/Control No.</b> 15495539	<b>Applicant(s)/Patent Under Reexamination</b> DA SILVA ET AL.
	<b>Examiner</b> GINA MCKIE	<b>Art Unit</b> 2631

✓	<b>Rejected</b>	-	<b>Cancelled</b>	N	<b>Non-Elected</b>	A	<b>Appeal</b>
=	<b>Allowed</b>	÷	<b>Restricted</b>	I	<b>Interference</b>	O	<b>Objected</b>

Claims renumbered in the same order as presented by applicant
  CPA
  T.D.
  R.1.47

CLAIM		DATE							
Final	Original	06/21/2017	01/19/2018	09/17/2018					
	1	✓	✓	✓					
	2	✓	✓	○					
	3	✓	✓	✓					
	4	✓	✓	✓					
	5	✓	✓	○					
	6	✓	✓	○					
	7	✓	✓	○					
	8	✓	✓	○					
	9	✓	✓	✓					
	10	✓	✓	✓					
	11	✓	✓	○					
	12	✓	✓	✓					
	13	✓	✓	○					
	14	✓	✓	○					
	15	✓	✓	○					
	16	✓	✓	○					
	17	✓	✓	✓					
	18	✓	✓	○					
	19	✓	✓	○					
	20	✓	✓	○					

PTO/SB/08 Equivalent

<b>INFORMATION DISCLOSURE STATEMENT BY APPLICANT</b>	Application No.	15/495,539	
	Filing Date	April 24, 2017	
	First Named Inventor	Marcus Da Silva	
	Art Unit	2631	
<i>(Multiple sheets used when necessary)</i>		Examiner	McKie, Gina M.
SHEET 1 OF 3		Attorney Docket No.	1640-001.203

U.S. PATENT DOCUMENTS					
Examiner Initials	Cite No.	Document Number <i>Number - Kind Code (if known)</i> Example: 1,234,567 B1	Publication Date MM-DD-YYYY	Name of Patentee or Applicant	Pages, Columns, Lines Where Relevant Passages or Relevant Figures Appear
	1	5,345,599 A	09-06-1994	Paulraj et al.	
	2	5,515,378 A	05-07-1996	Roy, III et al.	
	3	5,548,813 A	08-20-1996	Charas et al.	
	4	5,553,074 A	09-03-1996	Acampora	
	5	5,592,490 A	01-07-1997	Barratt et al.	
	6	5,634,199 A	05-27-1997	Gerlach et al.	
	7	5,890,067 A	03-30-1999	Chang et al.	
	8	6,115,427 A	09-05-2000	Calderbank et al.	
	9	6,169,759 B1	01-02-2001	Kanterakis et al.	
	10	6,208,858 B1	03-27-2001	Antonio et al.	
	11	6,359,923 B1	03-19-2002	Agee et al.	
	12	6,501,955 B1	12-31-2002	Durrant et al.	
	13	6,597,678 B1	07-22-2003	Kuwahara et al.	
	14	6,611,231 B2	08-26-2003	Crilly, Jr. et al.	
	15	6,778,988 B2	08-17-2004	Bengtson	
	16	6,795,409 B1	09-21-2004	Youssefmir et al.	
	17	7,031,266 B1	04-18-2006	Patel et al.	
	18	7,039,441 B1	05-02-2006	Reudink et al.	
	19	7,062,296 B2	06-13-2006	Brennan et al.	
	20	7,346,365 B1	03-18-2008	Hovers et al.	
	21	7,729,728 B2	06-01-2010	Brennan et al.	
	22	2004/0066762 A1	04-08-2004	Alastalo	

FOREIGN PATENT DOCUMENTS						
Examiner Initials	Cite No.	Foreign Patent Document <i>Country Code-Number-Kind Code</i> Example: JP 1234567 A1	Publication Date MM-DD-YYYY	Name of Patentee or Applicant	Pages, Columns, Lines Where Relevant Passages or Relevant Figures Appear	T <sup>1</sup>
	23	GB 2349045 A	10-18-2000	Khalab		
	24	WO 00/038455 A1	06-29-2000	Jetzek		
	25	WO 02/063836 A2	08-15-2002	Alastalo		

Examiner Signature /GINA M MCKIE/	Date Considered 09/17/2018
<p>*Examiner: Initial if reference considered, whether or not citation is in conformance with MPEP 609. Draw line through citation if not in conformance and not considered. Include copy of this form with next communication to applicant.</p>	

T<sup>1</sup> - Place a check mark in this area when an English language Translation is attached.

ALL REFERENCES CONSIDERED EXCEPT WHERE LINED THROUGH. /G.M.M/

PTO/SB/08 Equivalent

<b>INFORMATION DISCLOSURE STATEMENT BY APPLICANT</b>  <i>(Multiple sheets used when necessary)</i>	Application No.	15/495,539
	Filing Date	April 24, 2017
	First Named Inventor	Marcus Da Silva
	Art Unit	2631
SHEET 2 OF 3		Attorney Docket No. 1640-001.203

FOREIGN PATENT DOCUMENTS						
Examiner Initials	Cite No.	Foreign Patent Document <i>Country Code-Number-Kind Code</i> Example: JP 1234567 A1	Publication Date MM-DD-YYYY	Name of Patentee or Applicant	Pages, Columns, Lines Where Relevant Passages or Relevant Figures Appear	T <sup>1</sup>
	26	EP 1117270 A2	07-18-2001	Aravamudan et al.		

NON PATENT LITERATURE DOCUMENTS			
Examiner Initials	Cite No.	Include name of the author (in CAPITAL LETTERS), title of the article (when appropriate), title of the item (book, magazine, journal, serial, symposium, catalog, etc.), date, page(s), volume-issue number(s), publisher, city and/or country where published.	T <sup>1</sup>
	<del>27</del>	<del>Petition for Inter Partes Review of U.S. Patent No. 6,611,231; CISCO SYSTEMS, INC. v. XR COMMUNICATIONS LLC; Case No. IPR2018-00762; pages 1-92.</del>	<del>No dates</del>
	<del>28</del>	<del>Petition for Inter Partes Review of U.S. Patent No. 7,729,728; CISCO SYSTEMS, INC. v. XR COMMUNICATIONS LLC; Case No. IPR2018-00763; pages 1-72.</del>	
	<del>29</del>	<del>Petition for Inter Partes Review of U.S. Patent No. 7,062,296; CISCO SYSTEMS, INC. v. XR COMMUNICATIONS LLC; Case No. IPR2018-00764; pages 1-83.</del>	
	<del>30</del>	<del>Petition for Inter Partes Review of U.S. Patent No. 7,062,296; ARUBA NETWORKS, INC. v. XR COMMUNICATIONS, LLC; Case No. IPR2018-00725; pages 1-68.</del>	
	<del>31</del>	<del>Petition for Inter Partes Review of U.S. Patent No. 7,729,728; ARUBA NETWORKS, INC. v. XR COMMUNICATIONS, LLC; Case No. IPR2018-00726; pages 1-63.</del>	
	<del>32</del>	<del>Petition for Inter Partes Review of U.S. Patent No. 6,611,231; ARUBA NETWORKS, INC. v. XR COMMUNICATIONS, LLC; Case No. IPR2018-00701; pages 1-76.</del>	
	33	D. Gerlach and A. Paulraj, "Base Station Transmitter Arrays with Mobile to Base Feedback," Conference Record of the Twenty-Seventh Asilomar Conference on Signals, Systems & Computers, 1993, pages 1432-36.	
	34	I.A. Glover and P.M. Grant, <i>Digital Communications</i> , Prentice Hall Europe, 1998, pages 80-86, § 2.6, "Correlation functions".	
	35	ANSI/IEEE Standard 802.11: Wireless LAN Medium Access Control (MAC) and Physical Layer (PHY) Specifications, 1999 Edition.	
	36	Z.C. Fluhr and P.T. Porter, "Advanced Mobile Phone Service: Control Architecture," Bell System Technical Journal, Vol. 58, No. 1, January 1979, pp 43-69 ("Fluhr")	
	37	Hillebrand, ed., "GSM and UMTS: The Creation of Global Mobile Communication," John Wiley & Sons, Ltd., 2002, pp. 316-317 ("Hillebrand")	
	38	Andrew T. Campbell, et al., "Design, Implementation, and Evaluation of Cellular IP," IEEE PERSONAL COMMUNICATIONS (August 2000).	
	39	Donghee Shim, et al., "Should the Smart Antenna Be A Tracking Beam Array or Switching Beam Array?," 48 <sup>th</sup> IEEE Vehicular Technology Conference (VTC'98) (May 21, 1998).	
	40	Sandra Kay Miller, "Facing the Challenge of Wireless Security," COMPUTER, pp.16-18 (July 2001)	
	<del>41</del>	<del>"Radio Spectrum Allocation," Federal Communications Commission, available at <a href="https://www.fcc.gov/engineeringtechnology/policy-and-rules-division/general/radio-spectrumallocation">https://www.fcc.gov/engineeringtechnology/policy-and-rules-division/general/radio-spectrumallocation</a></del>	

Examiner Signature /GINA M MCKIE/	Date Considered 09/23/2018
<p>*Examiner: Initial if reference considered, whether or not citation is in conformance with MPEP 609. Draw line through citation if not in conformance and not considered. Include copy of this form with next communication to applicant.</p>	

T<sup>1</sup> - Place a check mark in this area when an English language Translation is attached.

ALL REFERENCES CONSIDERED EXCEPT WHERE LINED THROUGH. /G.M.M/



PTO/SB/08 Equivalent

<b>INFORMATION DISCLOSURE STATEMENT BY APPLICANT</b>  <i>(Multiple sheets used when necessary)</i>	Application No.	15/495,539
	Filing Date	April 24, 2017
	First Named Inventor	Marcus Da Silva
	Art Unit	2631
SHEET 3 OF 3	Examiner	McKie, Gina M.
	Attorney Docket No.	1640-001.203

**NON PATENT LITERATURE DOCUMENTS**

Examiner Initials	Cite No.	Include name of the author (in CAPITAL LETTERS), title of the article (when appropriate), title of the item (book, magazine, journal, serial, symposium, catalog, etc.), date, page(s), volume-issue number(s), publisher, city and/or country where published.	T <sup>1</sup>
	42	IEEE 802.11-1997	
	43	Jack H. Winters, "Smart Antennas," Chapter 6 of WTEC PANEL REPORT ON WIRELESS TECHNOLOGIES AND INFORMATION NETWORKS (July 2000).	
	44	Constantine Balanis, ANTENNA THEORY (1997) (selected pages).	
	45	S.C. Swales, et al., "The Performance Enhancement of Multibeam Adaptive Base-Station Antennas for Cellular Land Mobile Radio Systems," IEEE TRANSACTIONS ON VEHICULAR TECHNOLOGY, vol. 39, no. 1 (Feb. 1990).	
	46	John Litva, et al., DIGITAL BEAMFORMING IN WIRELESS NETWORKS (1996) (selected pages).	
	47	Joseph C. Liberti, Jr., et al., SMART ANTENNAS FOR WIRELESS COMMUNICATIONS (1999) (selected pages).	
	48	IEEE Standards Bearer (Oct. 1997)	
	49	Petition for Inter Partes Review of U.S. Patent No. 6,611,231; RUCKUS WIRELESS, INC. et al. v. XR COMMUNICATIONS LLC, Case No. IPR2018-01016, 87 pages.	No dates
	50	Petition for Inter Partes Review of U.S. Patent No. 7,062,296; RUCKUS WIRELESS, INC. et al. v. XR COMMUNICATIONS LLC, Case No. IPR2018-01017, 79 pages.	
	51	Petition for Inter Partes Review of U.S. Patent No. 7,729,728; RUCKUS WIRELESS, INC. et al. v. XR COMMUNICATIONS LLC, Case No. IPR2018-01018, 85 pages.	
	52	Oliver C. Ibe, Essentials of ATM Networks and Services, Addison Wesley (1997)	
	53	Andrew S. Tanenbaum, Computer Networks, Third Edition, Prentice Hall (1996)	
	54	Patent Owner's Preliminary Response, CISCO SYSTEMS, INC. v. XR COMMUNICATIONS LLC, Case No. IPR2018-00762, U.S. Patent No. 6,611,231, 38 pages.	
	55	Patent Owner's Preliminary Response, CISCO SYSTEMS, INC. v. XR COMMUNICATIONS LLC, Case No. IPR2018-00764, U.S. Patent No. 7,062,296, 47 pages.	
	56	Patent Owner's Preliminary Response, ARUBA NETWORKS, INC. v. XR COMMUNICATIONS, LLC, Case No. IPR2018-00725, U.S. Patent No. 7,062,296, 35 pages.	
	57	Patent Owner's Preliminary Response, ARUBA NETWORKS, INC. v. XR COMMUNICATIONS, LLC, Case No. IPR2018-00701, U.S. Patent No. 6,611,231, 51 pages.	

Examiner Signature /GINA M MCKIE/	Date Considered 09/17/2018
<p>*Examiner: Initial if reference considered, whether or not citation is in conformance with MPEP 609. Draw line through citation if not in conformance and not considered. Include copy of this form with next communication to applicant.</p>	

T<sup>1</sup> - Place a check mark in this area when an English language Translation is attached.

ALL REFERENCES CONSIDERED EXCEPT WHERE LINED THROUGH. /G.M.M/

## EAST Search History

## EAST Search History (Prior Art)

Ref #	Hits	Search Query	DBs	Default Operator	Plurals	Time Stamp
S1	1165	375/365.CCLS.	US-PGPUB; USPAT; USOCR; FPRS; EPO; JPO; DERWENT; IBM_TDB	OR	OFF	2017/06/22 11:46
S2	2	"20020158801"	US-PGPUB; USPAT; USOCR; FPRS; EPO; JPO; DERWENT; IBM_TDB	OR	OFF	2018/09/17 09:12
S3	88	("2002/0158801").URPN.	USPAT	OR	ON	2018/09/17 10:25
S4	994	"directed wireless communication"	USPAT	OR	ON	2018/09/17 11:02
S5	2396	"directed wireless communication"	US-PGPUB; USPAT; USOCR; FPRS; EPO; JPO; DERWENT; IBM_TDB	OR	ON	2018/09/17 11:04
S6	26	"directed wireless communication" AND multi-beam	US-PGPUB; USPAT; USOCR; FPRS; EPO; JPO; DERWENT; IBM_TDB	OR	ON	2018/09/17 11:04
S7	51	multi-beam WITH directed WITH communication	US-PGPUB; USPAT; USOCR; FPRS; EPO; JPO; DERWENT; IBM_TDB	OR	ON	2018/09/17 11:08
S8	349	multi-beam AND Wi-Fi	US-PGPUB; USPAT; USOCR; FPRS; EPO; JPO; DERWENT; IBM_TDB	OR	ON	2018/09/17 11:15
S9	327	multi-beam AND Wi-Fi AND array	US-PGPUB; USPAT; USOCR; FPRS; EPO; JPO; DERWENT; IBM_TDB	OR	ON	2018/09/17 11:25
S10	9134	multi-beam AND array	US-PGPUB; USPAT; USOCR; FPRS; EPO; JPO; DERWENT; IBM_TDB	OR	ON	2018/09/17 11:29
S11	585	multi-beam AND array AND "access point"	US-PGPUB; USPAT; USOCR; FPRS; EPO; JPO; DERWENT; IBM_TDB	OR	ON	2018/09/17 11:32
S12	2050	multi-beam AND array AND directional	US-PGPUB; USPAT; USOCR; FPRS; EPO; JPO; DERWENT; IBM_TDB	OR	ON	2018/09/17 11:32
S13	0	S11 AND @ad<"2003"	US-PGPUB; USPAT; USOCR; FPRS; EPO; JPO; DERWENT; IBM_TDB	OR	ON	2018/09/17 11:35

## EAST Search History

S14	16	S11 AND @ad< "20030101"	US-PGPUB; USPAT; USOCR; FPRS; EPO; JPO; DERWENT; IBM_TDB	OR	ON	2018/09/17 11:35
S15	312593	first ADJ signal	US-PGPUB; USPAT; USOCR; FPRS; EPO; JPO; DERWENT; IBM_TDB	OR	ON	2018/09/17 11:42
S16	309870	second ADJ signal	US-PGPUB; USPAT; USOCR; FPRS; EPO; JPO; DERWENT; IBM_TDB	OR	ON	2018/09/17 11:43
S17	38189	remote ADJ station	US-PGPUB; USPAT; USOCR; FPRS; EPO; JPO; DERWENT; IBM_TDB	OR	ON	2018/09/17 11:43
S18	112197	set NEAR2 weight\$3	US-PGPUB; USPAT; USOCR; FPRS; EPO; JPO; DERWENT; IBM_TDB	OR	ON	2018/09/17 11:45
S19	109	S15 AND S16 AND S17 AND S18	US-PGPUB; USPAT; USOCR; FPRS; EPO; JPO; DERWENT; IBM_TDB	OR	ON	2018/09/17 11:46
S20	4361	"first signal" WITH "second signal" WITH simultaneous\$3	US-PGPUB; USPAT; USOCR; FPRS; EPO; JPO; DERWENT; IBM_TDB	OR	ON	2018/09/17 11:54
S21	34	S18 AND S20	US-PGPUB; USPAT; USOCR; FPRS; EPO; JPO; DERWENT; IBM_TDB	OR	ON	2018/09/17 12:03
S22	14	S20 AND "multi-beam"	US-PGPUB; USPAT; USOCR; FPRS; EPO; JPO; DERWENT; IBM_TDB	OR	ON	2018/09/17 12:04
S23	436	S12 AND @ad< "20030101"	US-PGPUB; USPAT; USOCR; FPRS; EPO; JPO; DERWENT; IBM_TDB	OR	ON	2018/09/17 12:08
S24	43	S23 AND ("first signal") AND "second signal"	US-PGPUB; USPAT; USOCR; FPRS; EPO; JPO; DERWENT; IBM_TDB	OR	ON	2018/09/17 12:11

9/ 17/ 2018 1:26:19 PM

C:\Users\gmckie\Documents\EAST\Workspaces\15495539.wsp

<b>INFORMATION DISCLOSURE STATEMENT BY APPLICANT</b>	Application No.	15/495,539	
	Filing Date	April 24, 2017	
	First Named Inventor	Marcus Da Silva	
	Art Unit	2631	
<i>(Multiple sheets used when necessary)</i>		Examiner	McKie, Gina M.
SHEET 1 OF 3		Attorney Docket No.	1640-001.203

U.S. PATENT DOCUMENTS					
Examiner Initials	Cite No.	Document Number <i>Number - Kind Code (if known)</i> Example: 1,234,567 B1	Publication Date MM-DD-YYYY	Name of Patentee or Applicant	Pages, Columns, Lines Where Relevant Passages or Relevant Figures Appear
	1	5,345,599 A	09-06-1994	Paulraj et al.	
	2	5,515,378 A	05-07-1996	Roy, III et al.	
	3	5,548,813 A	08-20-1996	Charas et al.	
	4	5,553,074 A	09-03-1996	Acampora	
	5	5,592,490 A	01-07-1997	Barratt et al.	
	6	5,634,199 A	05-27-1997	Gerlach et al.	
	7	5,890,067 A	03-30-1999	Chang et al.	
	8	6,115,427 A	09-05-2000	Calderbank et al.	
	9	6,169,759 B1	01-02-2001	Kanterakis et al.	
	10	6,208,858 B1	03-27-2001	Antonio et al.	
	11	6,359,923 B1	03-19-2002	Agee et al.	
	12	6,501,955 B1	12-31-2002	Durrant et al.	
	13	6,597,678 B1	07-22-2003	Kuwahara et al.	
	14	6,611,231 B2	08-26-2003	Crilly, Jr. et al.	
	15	6,778,988 B2	08-17-2004	Bengtson	
	16	6,795,409 B1	09-21-2004	Youssefmir et al.	
	17	7,031,266 B1	04-18-2006	Patel et al.	
	18	7,039,441 B1	05-02-2006	Reudink et al.	
	19	7,062,296 B2	06-13-2006	Brennan et al.	
	20	7,346,365 B1	03-18-2008	Hovers et al.	
	21	7,729,728 B2	06-01-2010	Brennan et al.	
	22	2004/0066762 A1	04-08-2004	Alastalo	

FOREIGN PATENT DOCUMENTS						
Examiner Initials	Cite No.	Foreign Patent Document <i>Country Code-Number-Kind Code</i> Example: JP 1234567 A1	Publication Date MM-DD-YYYY	Name of Patentee or Applicant	Pages, Columns, Lines Where Relevant Passages or Relevant Figures Appear	T <sup>1</sup>
	23	GB 2349045 A	10-18-2000	Khalab		
	24	WO 00/038455 A1	06-29-2000	Jetzek		
	25	WO 02/063836 A2	08-15-2002	Alastalo		

Examiner Signature	Date Considered
*Examiner: Initial if reference considered, whether or not citation is in conformance with MPEP 609. Draw line through citation if not in conformance and not considered. Include copy of this form with next communication to applicant.	

T<sup>1</sup> - Place a check mark in this area when an English language Translation is attached.

<b>INFORMATION DISCLOSURE STATEMENT BY APPLICANT</b>	Application No.	15/495,539	
	Filing Date	April 24, 2017	
	First Named Inventor	Marcus Da Silva	
	Art Unit	2631	
<i>(Multiple sheets used when necessary)</i>		Examiner	McKie, Gina M.
SHEET 2 OF 3		Attorney Docket No.	1640-001.203

FOREIGN PATENT DOCUMENTS						
Examiner Initials	Cite No.	Foreign Patent Document <i>Country Code-Number-Kind Code</i> Example: JP 1234567 A1	Publication Date MM-DD-YYYY	Name of Patentee or Applicant	Pages, Columns, Lines Where Relevant Passages or Relevant Figures Appear	T <sup>1</sup>
	26	EP 1117270 A2	07-18-2001	Aravamudan et al.		

NON PATENT LITERATURE DOCUMENTS			
Examiner Initials	Cite No.	Include name of the author (in CAPITAL LETTERS), title of the article (when appropriate), title of the item (book, magazine, journal, serial, symposium, catalog, etc.), date, page(s), volume-issue number(s), publisher, city and/or country where published.	T <sup>1</sup>
	27	Petition for Inter Partes Review of U.S. Patent No. 6,611,231; CISCO SYSTEMS, INC. v. XR COMMUNICATIONS LLC; Case No. IPR2018-00762; pages 1-92.	
	28	Petition for Inter Partes Review of U.S. Patent No. 7,729,728; CISCO SYSTEMS, INC. v. XR COMMUNICATIONS LLC; Case No. IPR2018-00763; pages 1-72.	
	29	Petition for Inter Partes Review of U.S. Patent No. 7,062,296; CISCO SYSTEMS, INC. v. XR COMMUNICATIONS LLC; Case No. IPR2018-00764; pages 1-83.	
	30	Petition for Inter Partes Review of U.S. Patent No. 7,062,296; ARUBA NETWORKS, INC. v. XR COMMUNICATIONS, LLC, Case No. IPR2018-00725; pages 1-68.	
	31	Petition for Inter Partes Review of U.S. Patent No. 7,729,728; ARUBA NETWORKS, INC. v. XR COMMUNICATIONS, LLC, Case No. IPR2018-00726; pages 1-53.	
	32	Petition for Inter Partes Review of U.S. Patent No. 6,611,231; ARUBA NETWORKS, INC. v. XR COMMUNICATIONS, LLC, Case No. IPR2018-00701; pages 1-76.	
	33	D. Gerlach and A. Paulraj, "Base Station Transmitter Arrays with Mobile to Base Feedback," Conference Record of the Twenty-Seventh Asilomar Conference on Signals, Systems & Computers, 1993, pages 1432-36.	
	34	I.A. Glover and P.M. Grant, <i>Digital Communications</i> , Prentice Hall Europe, 1998, pages 80-86, § 2.6, "Correlation functions".	
	35	ANSI/IEEE Standard 802.11: Wireless LAN Medium Access Control (MAC) and Physical Layer (PHY) Specifications, 1999 Edition.	
	36	Z.C. Fluhr and P.T. Porter, "Advanced Mobile Phone Service: Control Architecture," Bell System Technical Journal, Vol. 58, No. 1, January 1979, pp 43-69 ("Fluhr")	
	37	Hillebrand, ed., "GSM and UMTS: The Creation of Global Mobile Communication," John Wiley & Sons, Ltd., 2002, pp. 316-317 ("Hillebrand")	
	38	Andrew T. Campbell, et al., "Design, Implementation, and Evaluation of Cellular IP," IEEE PERSONAL COMMUNICATIONS (August 2000).	
	39	Donghee Shim, et al., "Should the Smart Antenna Be A Tracking Beam Array or Switching Beam Array?," 48 <sup>th</sup> IEEE Vehicular Technology Conference (VTC'98) (May 21, 1998).	
	40	Sandra Kay Miller, "Facing the Challenge of Wireless Security," COMPUTER, pp.16-18 (July 2001)	
	41	"Radio Spectrum Allocation," Federal Communications Commission, available at <a href="https://www.fcc.gov/engineeringtechnology/policy-and-rules-division/general/radio-spectrumallocation">https://www.fcc.gov/engineeringtechnology/policy-and-rules-division/general/radio-spectrumallocation</a>	

Examiner Signature	Date Considered
<p>*<b>Examiner:</b> Initial if reference considered, whether or not citation is in conformance with MPEP 609. Draw line through citation if not in conformance and not considered. Include copy of this form with next communication to applicant.</p>	

T<sup>1</sup> - Place a check mark in this area when an English language Translation is attached.

<b>INFORMATION DISCLOSURE STATEMENT BY APPLICANT</b>	Application No.	15/495,539
	Filing Date	April 24, 2017
	First Named Inventor	Marcus Da Silva
	Art Unit	2631
<i>(Multiple sheets used when necessary)</i>	Examiner	McKie, Gina M.
SHEET 3 OF 3	Attorney Docket No.	1640-001.203

NON PATENT LITERATURE DOCUMENTS			
Examiner Initials	Cite No.	Include name of the author (in CAPITAL LETTERS), title of the article (when appropriate), title of the item (book, magazine, journal, serial, symposium, catalog, etc.), date, page(s), volume-issue number(s), publisher, city and/or country where published.	T <sup>1</sup>
	42	IEEE 802.11-1997	
	43	Jack H. Winters, "Smart Antennas," Chapter 6 of WTEC PANEL REPORT ON WIRELESS TECHNOLOGIES AND INFORMATION NETWORKS (July 2000).	
	44	Constantine Balanis, ANTENNA THEORY (1997) (selected pages).	
	45	S.C. Swales, et al., "The Performance Enhancement of Multibeam Adaptive Base-Station Antennas for Cellular Land Mobile Radio Systems," IEEE TRANSACTIONS ON VEHICULAR TECHNOLOGY, vol. 39, no. 1 (Feb. 1990).	
	46	John Litva, et al., DIGITAL BEAMFORMING IN WIRELESS NETWORKS (1996) (selected pages).	
	47	Joseph C. Liberti, Jr., et al., SMART ANTENNAS FOR WIRELESS COMMUNICATIONS (1999) (selected pages).	
	48	IEEE Standards Bearer (Oct. 1997)	
	49	Petition for Inter Partes Review of U.S. Patent No. 6,611,231; RUCKUS WIRELESS, INC. et al. v. XR COMMUNICATIONS LLC; Case No. IPR2018-01016; 87 pages.	
	50	Petition for Inter Partes Review of U.S. Patent No. 7,062,296; RUCKUS WIRELESS, INC. et al. v. XR COMMUNICATIONS LLC; Case No. IPR2018-01017; 79 pages.	
	51	Petition for Inter Partes Review of U.S. Patent No. 7,729,728; RUCKUS WIRELESS, INC. et al. v. XR COMMUNICATIONS LLC; Case No. IPR2018-01018; 65 pages.	
	52	Oliver C. Ibe, Essentials of ATM Networks and Services, Addison Wesley (1997)	
	53	Andrew S. Tanenbaum, Computer Networks, Third Edition, Prentice Hall (1996)	
	54	Patent Owner's Preliminary Response, CISCO SYSTEMS, INC. v. XR COMMUNICATIONS LLC, Case No. IPR2018-00762, U.S. Patent No. 6,611,231, 38 pages.	
	55	Patent Owner's Preliminary Response, CISCO SYSTEMS, INC. v. XR COMMUNICATIONS LLC, Case No. IPR2018-00764, U.S. Patent No. 7,062,296, 47 pages.	
	56	Patent Owner's Preliminary Response, ARUBA NETWORKS, INC. v. XR COMMUNICATIONS, LLC, Case No. IPR2018-00725, U.S. Patent No. 7,062,296, 35 pages.	
	57	Patent Owner's Preliminary Response, ARUBA NETWORKS, INC. v. XR COMMUNICATIONS, LLC, Case No. IPR2018-00701, U.S. Patent No. 6,611,231, 51 pages.	

Examiner Signature	Date Considered
<p>*Examiner: Initial if reference considered, whether or not citation is in conformance with MPEP 609. Draw line through citation if not in conformance and not considered. Include copy of this form with next communication to applicant.</p>	

T<sup>1</sup> - Place a check mark in this area when an English language Translation is attached.

### INFORMATION DISCLOSURE STATEMENT

Applicant	:	Marcus Da Silva
App. No	:	15/495,539
Filed	:	April 24, 2017
For	:	DIRECTED WIRELESS COMMUNICATION
Examiner	:	McKie, Gina M.
Art Unit	:	2631
Conf No.	:	1050

Commissioner for Patents  
P.O. Box 1450  
Alexandria, VA 22313-1450

#### Remarks

The present application claims priority to US Ser. No. 60/423,660. Two issued patents – US Pat. Nos. 7,062,296 and 7,729,728 – also claim priority to US Ser. No. 60/423,660, but are otherwise unrelated to the present application. US Pat. No. 6,611,231 is unrelated to the present application, but is owned by the assignee of the present application.

The '296, '728 and '231 patents are currently the subject of litigation in the Central District of California. Also, petitions for Inter Partes Review (IPR) have been filed for each of these patents. Submitted herewith are references and documents taken from each of the IPR proceedings, which include:

For the '296 patent:

- IPR2018-00725
- IPR2018-00764
- IPR2018-01017

For the '728 patent:

- IPR2018-00726
- IPR2018-00763

**Application No.:** 15/495,539  
**Filing Date:** April 24, 2017

- IPR2018-01018

For the '231 patent:

- IPR2018-00762
- IPR2018-00701
- IPR2018-01016

Listed below are the pending lawsuits concerning the '231, '296 and '728 patents in the Central District of California:

- XR Communications, LLC, d/b/a Vivato Technologies v. D-Link Systems, Inc., 8:17-cv-0596;
- XR Communications, LLC, d/b/a Vivato Technologies v. Belkin International, Inc., 8:17-cv-00674;
- XR Communications, LLC, d/b/a Vivato Technologies v. Xirrus, Inc., 3:17-cv-00675;
- XR Communications, LLC, d/b/a Vivato Technologies v. Ubiquiti Networks, Inc., 2:17-cv-02968;
- XR Communications, LLC, d/b/a Vivato Technologies v. Ruckus Wireless, Inc., 2:17-cv-02961;
- XR Communications, LLC, d/b/a Vivato Technologies v. NETGEAR, Inc., 2:17-cv-02959;
- XR Communications, LLC, d/b/a Vivato Technologies v. Extreme Networks, Inc., 2:17-cv-02953;
- XR Communications, LLC, d/b/a Vivato Technologies v. Cisco Systems, Inc., 2:17-cv-02951;
- XR Communications, LLC, d/b/a Vivato Technologies v. ASUS Computer International, et al, 2:17-cv-02948;
- XR Communications, LLC, d/b/a Vivato Technologies v. Newo Corporation d/b/a Amped Wireless, 5:17-cv-00744;



**Application No.:** 15/495,539  
**Filing Date:** April 24, 2017

- XR Communications, LLC, d/b/a Vivato Technologies v. Aruba Networks, Inc., 2:17-cv-02945; and
- XR Communications, LLC, d/b/a Vivato Technologies v. ARRIS International plc, et al, 8:18-cv-00192.

**Timing of Disclosure**

This Information Disclosure Statement is being filed before the receipt of a first Office Action on the merits after filing a request for continued examination under 35 CFR 1.114, and presumably no fee is required. If a first Office Action on the merits was transmitted before the transmittal date of this Information Disclosure Statement, the please charge the appropriate fee to Deposit Account No. 11-1159.

Respectfully submitted,  
KLEIN, O'NEILL & SINGH, LLP

Dated: July 31, 2018

By: /Glen L Nuttall/  
Glen L. Nuttall  
Registration No. 46,188  
Attorney of Record

(12) UK Patent Application (19) GB (11) 2 349 045 (13) A

(43) Date of A Publication 18.10.2000

(21) Application No 9908839.5

(22) Date of Filing 16.04.1999

(71) Applicant(s)  
**Fujitsu Limited**  
(Incorporated in Japan)  
1-1 Kamikodanaka 4-chome, Nakahara-ku,  
Kawasaki-shi, Kanagawa 211-8588, Japan

(72) Inventor(s)  
**Jamal Muftah Khalaf**

(74) Agent and/or Address for Service  
**Haseltine Lake & Co**  
Imperial House, 15-19 Kingsway, LONDON,  
WC2B 6UD, United Kingdom

(51) INT CL<sup>7</sup>  
H04Q 7/36 , H01Q 1/24 3/26 , H04Q 7/30

(52) UK CL (Edition R )  
H4L LDSG LDSL L1H10  
H1Q QFC

(56) Documents Cited  
GB 2328800 A GB 2318947 A GB 2316807 A  
GB 2307142 A EP 0841827 A2 WO 99/22423 A1  
WO 98/16077 A2 US 5260968 A

(58) Field of Search  
UK CL (Edition Q ) H1Q QFA QFC QFF QFH , H4L LDLX  
LDSG LDSL LECX LFNX  
INT CL<sup>6</sup> H01Q 1/24 3/26 3/30 3/34 3/36 3/38 3/40 ,  
H04Q 7/30 7/36 7/38  
ONLINE - EPODOC, WPI

(54) Abstract Title  
**Base station transmission beam pattern forming; interference reduction**

(57) A base station identifies, for a particular or desired mobile user, one or more other mobile users that are to be treated as vulnerable users potentially adversely affected by a downlink signal transmission from the base station to the desired user. A downlink transmission beam pattern is then formed which has a main beam with a direction matching the direction of the desired user and one or more nulls matching the direction or directions of one or more vulnerable users. Transmission data rate to the desired user and/or distance to the desired user may be used as criteria in determining whether this transmission is likely to render other users vulnerable to interference. A user data register (UDR) 14 stores data including direction of arrival (DOA) data for signals received by the base station from the desired and vulnerable users. From data in the UDR 14, a selection unit 16 determines one or more of: the DOA information for the desired user, distances of users from the base station, users who are close to high bit rate users, and users close to clusters of other users. From that data, a list of vulnerable users is generated by the unit 16 which sends the direction information for the desired and vulnerable users to an optimum weights unit 12 which calculates weights input to a downlink beamformer 20 so that the required beam pattern may be formed by transmission antenna elements. Any users for whom provision of a null would degrade the pattern for the desired user are removed from the vulnerable list. Where there is a cluster of vulnerable users, a null may be formed in the mean direction of the cluster. With N transmission antenna elements, N- 1 nulls can be formed, so that if there are more than N-1 vulnerable users, the N- 1 most vulnerable users are selected.

The receiving section of the base station may have an adaptive beamformer with an adaptive algorithm 26 which inputs a weight vector to a vector multiplier 22. A direction of arrival (DOA) determining unit 30 estimates the DOA of a user from the weight vector. The unit 30 may estimate the DOA by finding the peak of the uplink beam pattern, eg. by calculating the uplink beamformer gain at different DOAs and identifying the DOA for which the gain is the highest.

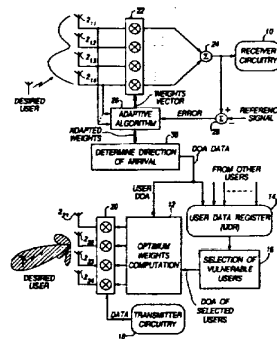


Fig.2

At least one drawing originally filed was informal and the print reproduced here is taken from a later filed formal copy.

GB 2 349 045 A

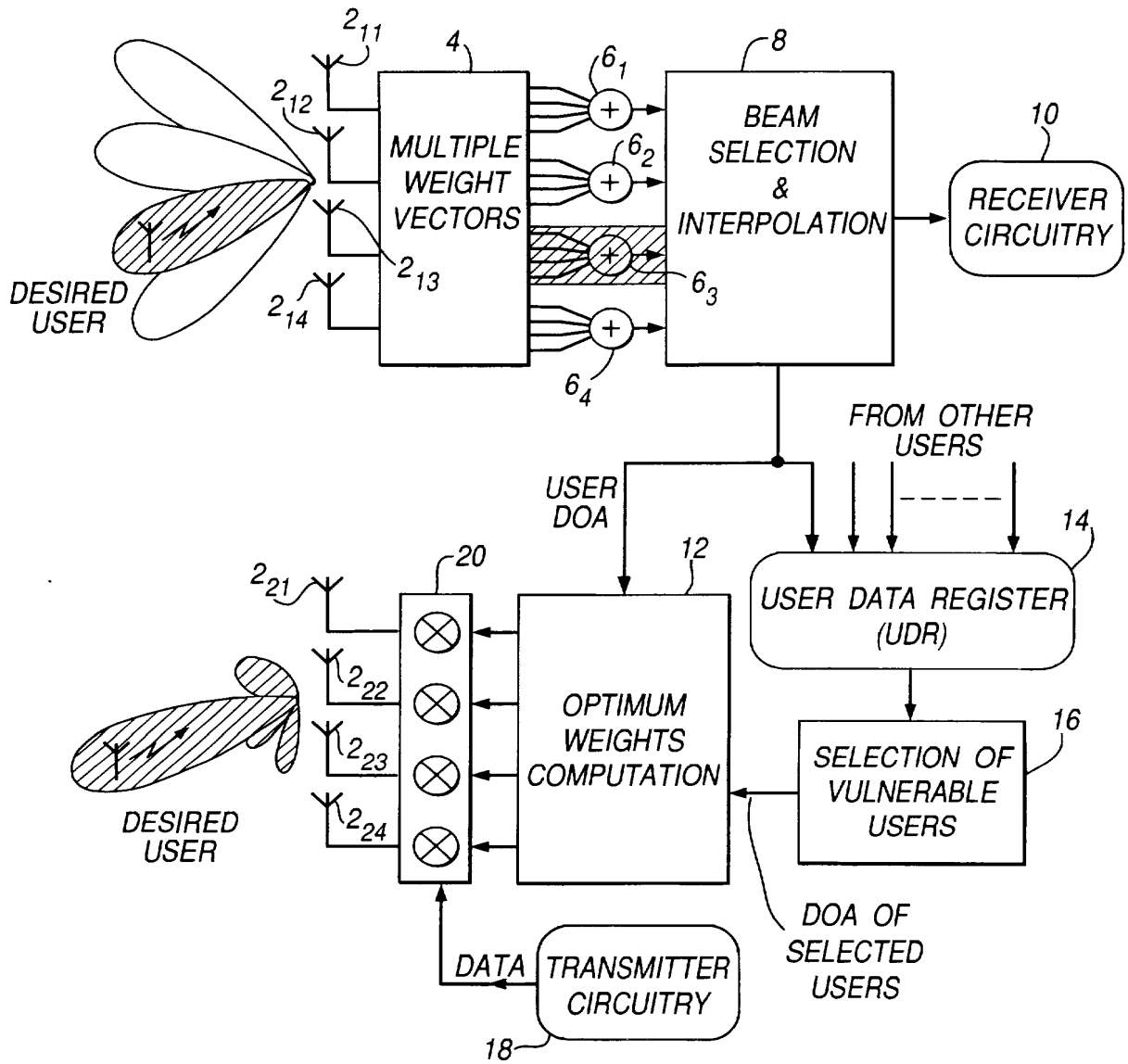


Fig. 1

2/7

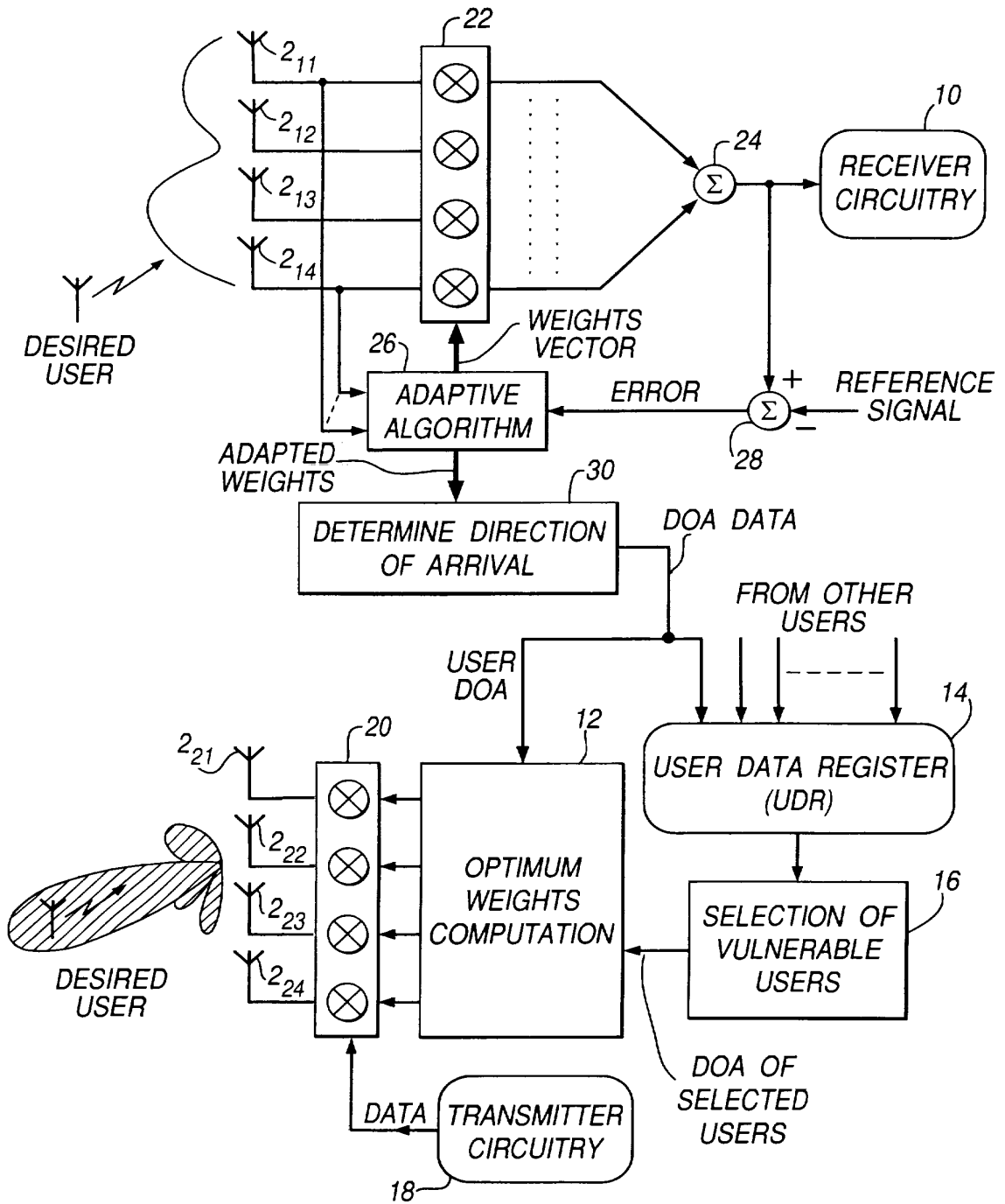


Fig.2

3/7

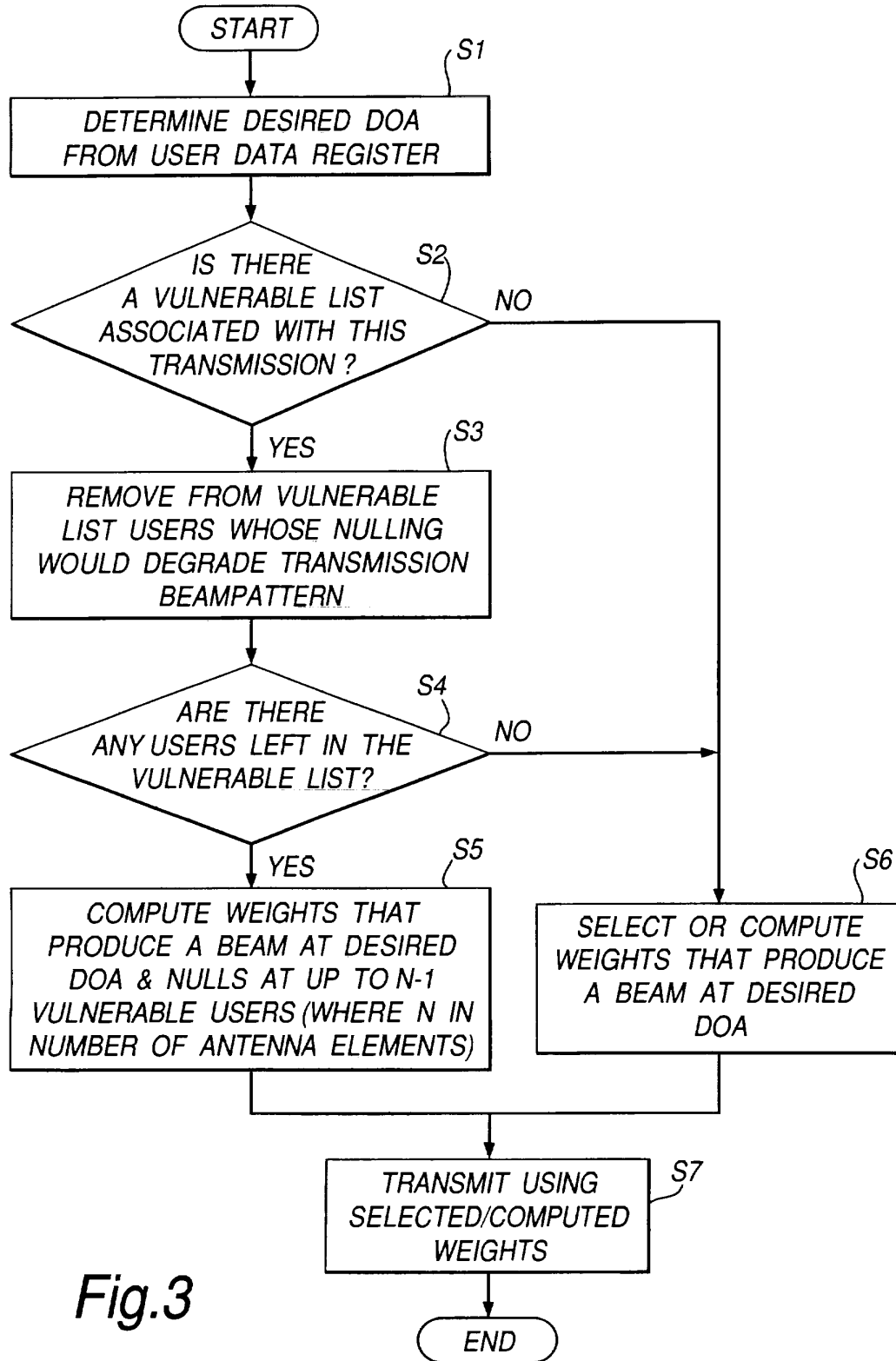


Fig.3

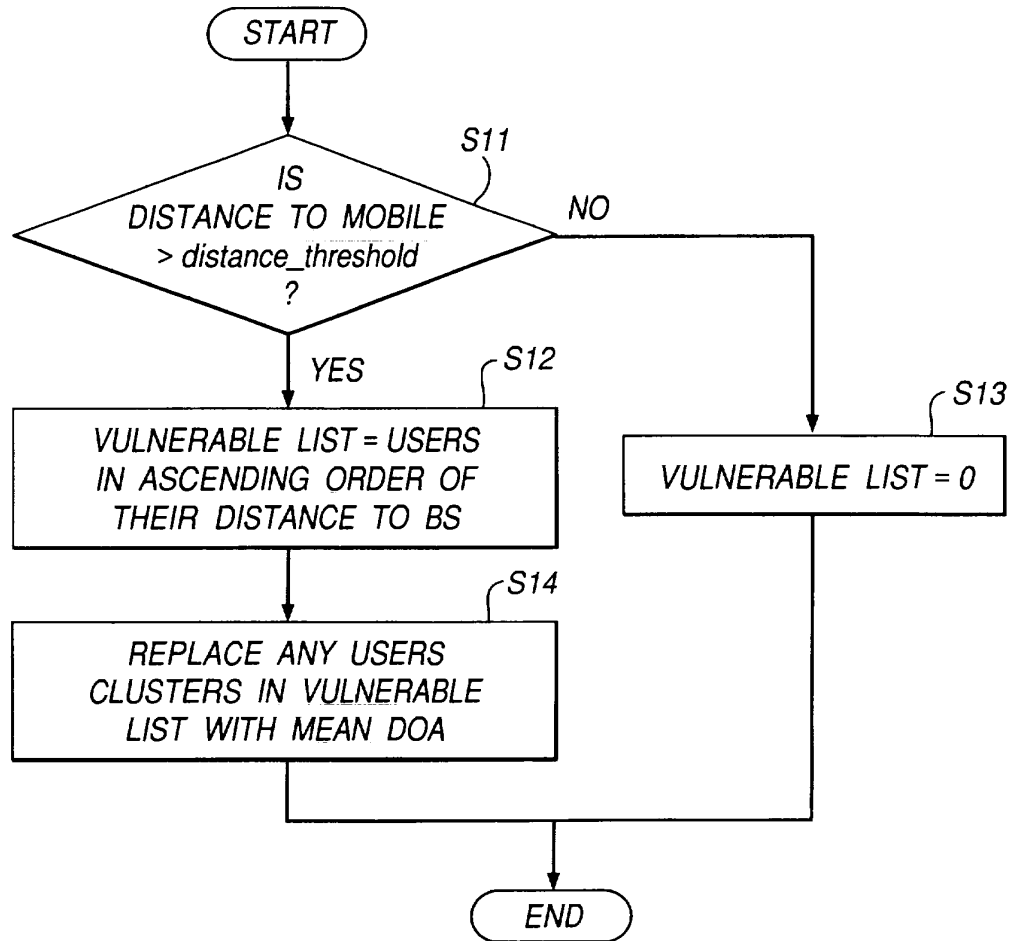


Fig. 4

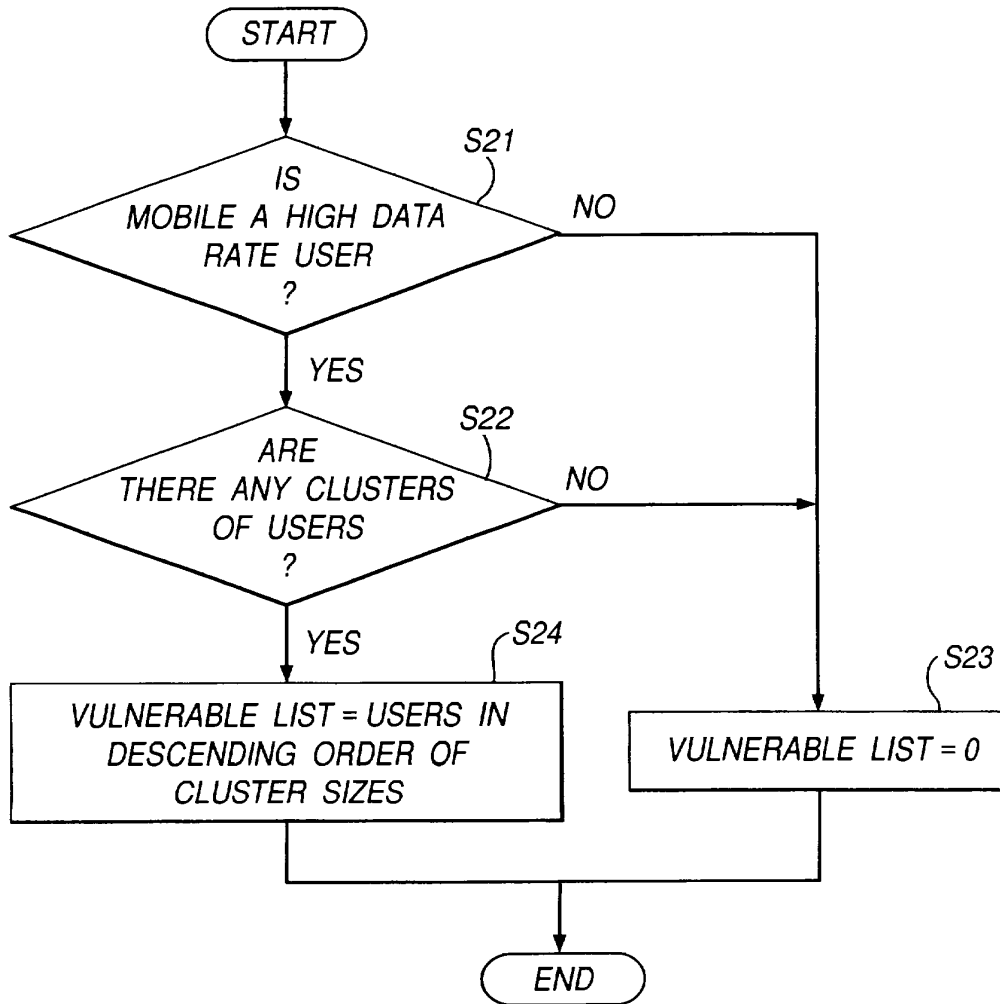


Fig.5

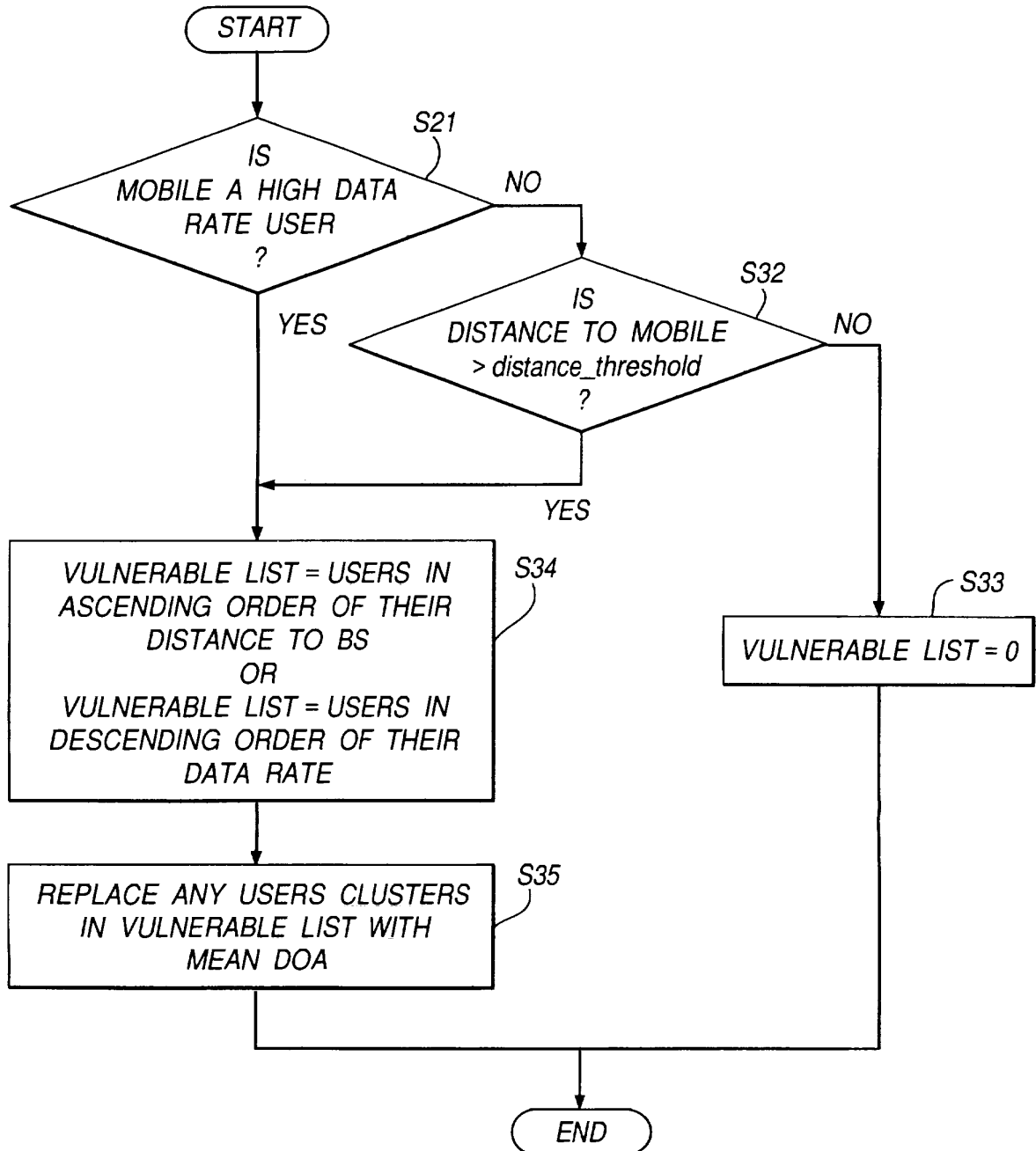


Fig. 6



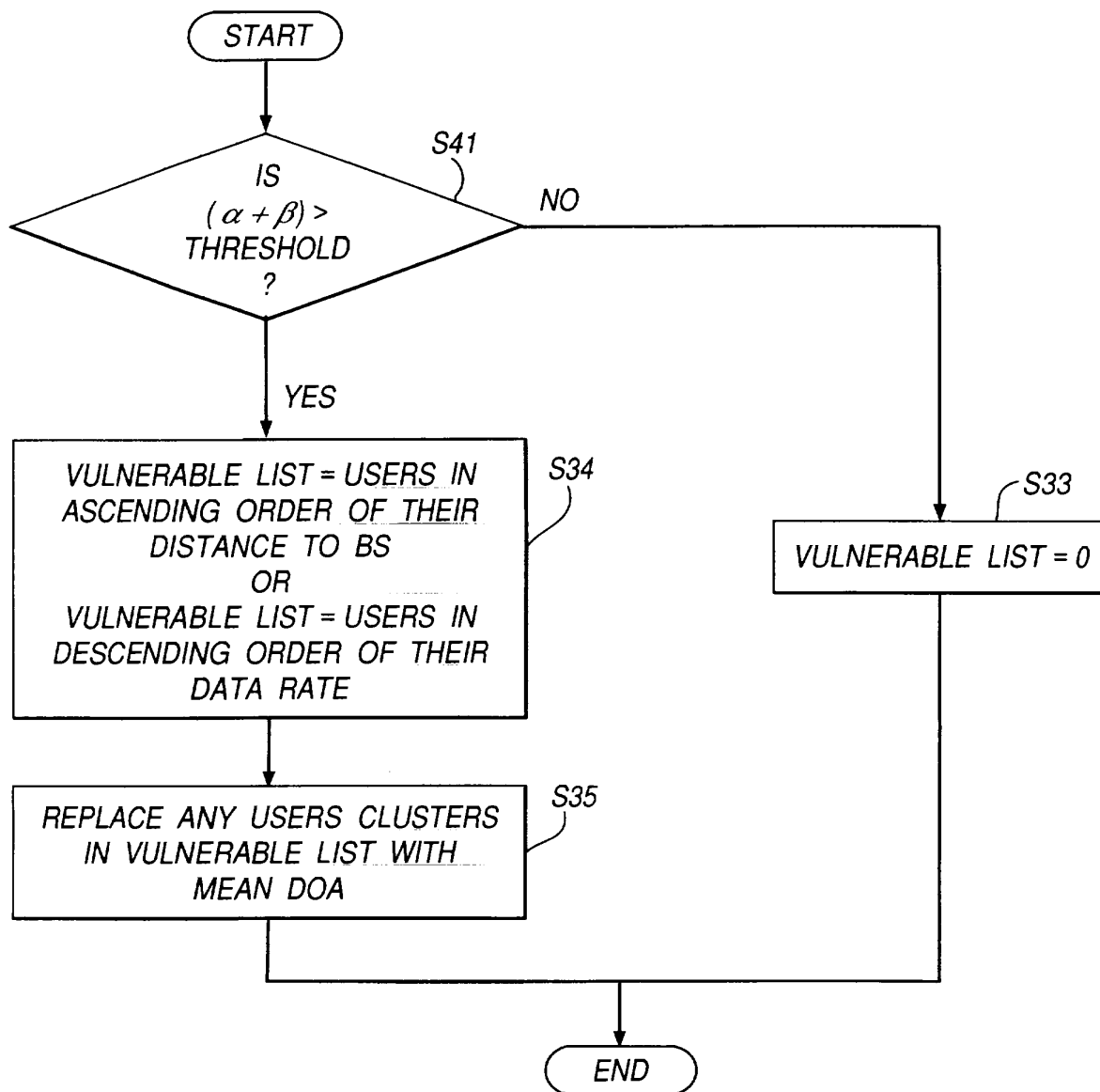


Fig. 7

TRANSMISSION METHODS AND APPARATUS

5 The present invention relates to transmission  
methods and apparatus. In particular, but not  
exclusively, the present invention relates to  
transmission methods and apparatus for use in a base  
station of a cellular mobile communications system.

10 In a cellular mobile communications system, it is  
necessary for a base station to be able to detect  
uplink signals transmitted by a desired mobile station  
(user) to the base station and be able to transmit  
downlink signals back to that desired user.

15 A given desired user may be at any angular  
direction from the base station and a simple approach  
to transmission and detection of signals would be to  
transmit and "look for" all signals in all directions.

20 However, adaptive antennae techniques and  
beamforming techniques have been proposed for use in  
mobile communications systems such as the Universal  
Mobile Telecommunication System (UMTS). These  
techniques can provide improvements in performance  
and/or spectral efficiency of the system.

25 Most of the proposed adaptive antennae/beamforming  
techniques have been applied to reception of uplink  
signals at the base station. The principle underlying  
one such uplink beamforming technique is to process  
signals received from an adaptive antenna array at the  
base station to form a spatial beam pattern such that  
30 the angle of arrival of the uplink signal of a wanted  
user falls well within a main lobe of the beam pattern  
whereas interfering signals from other users are  
located as much as possible in the nulls, low side  
lobes or boundary regions of the main lobe.

35 However, as such uplink beamforming techniques  
improve, transmission of downlink signals from the base

station is becoming the system bottleneck. Downlink beamforming is one approach being considered to alleviate this potential bottleneck.

5 In Time Division Duplexing (TDD) systems, the channel between the desired user and the base station can be assumed to be the same for the uplink and the downlink. Therefore, if uplink beamforming is being performed, exactly the same beam pattern can be used for the downlink as in the uplink.

10 In Frequency Division Duplexing (FDD) systems the channel estimation performed in the uplink cannot be directly applied to the downlink. Due to the difference in frequency, there is no channel-impulse-response reciprocity between the uplink and the  
15 downlink. Beam reciprocity, however, does exist provided that the channel is substantially static between reception and transmission. Downlink beamforming can then be applied by simply pointing a beam in the user direction during transmission.

20 However, although such downlink beamforming approaches are expected to result in better performance than omnidirectional transmission, these approaches do not take into account the possible adverse affects on other users of the downlink signal transmission to a  
25 particular wanted user.

According to a first aspect of the present invention, there is provided a transmission method, for use in a mobile communications network, including the steps of: in a base station of the network,  
30 identifying, for a particular user of the network, one or more other mobile users that are to be treated as vulnerable users potentially adversely affected by a downlink signal transmission from the base station to the particular mobile user; determining a downlink beam  
35 pattern including a main beam having a direction matching a direction of the particular mobile user and

also including a null having a direction matching a direction of at least one of the said vulnerable users; and transmitting such a downlink signal to the said particular mobile user using the determined beam pattern.

5

Such a transmission method can form a more intelligent transmission beam pattern comprising a pointed beam and some nulls, the nulls being selected using user information available to the base station.

10

Incidentally, the term "matching", as used herein, does not require absolute equality of direction; only approximate equality is intended and some angular divergence is contemplated in practical systems.

15

In one embodiment the direction of the said particular mobile user and of the or each said vulnerable user is determined by processing an uplink signal received at the base station from the user concerned. Such a transmission method has the advantage that it makes use of information readily available in the base station.

20

Preferably, the said direction of the said particular mobile user and of the or each said vulnerable user is derived from an uplink beam pattern employed by the base station to process a received uplink signal from the user concerned. Such a transmission method has the advantage that it makes use of information readily available in the base station.

25

In one embodiment, the uplink beam pattern is adapted in use by the said base station; and an estimate of the direction of each said mobile user is derived from an adjustable weight vector corresponding to the uplink beam pattern determined for that user. Such a transmission method has the advantage that it makes use of information readily available in the base station.

30

35

Preferably, in the pattern determining step, any

identified vulnerable user whose direction would require the said downlink beam pattern to include such a null within, or near to, the said main beam is ignored. Such a transmission method has the advantage that the quality of the transmission to the desired user is not greatly degraded.

5

In one embodiment, the said downlink beam pattern is calculated based on the respective directions of the said particular mobile user and the or each said vulnerable user. Such a transmission method has the advantage that the locations of the peak and the nulls of the beam can be optimised.

10

Alternatively, in another embodiment, the determined downlink beam pattern is a best-matching downlink beam pattern selected from amongst a plurality of predetermined candidate downlink beam patterns. Such a transmission method has the advantage that the complexity of mathematical calculation required for each downlink signal to be transmitted is reduced.

15

One embodiment further includes an interference judging step of judging, for the said particular mobile user, whether, based on one or more predetermined criteria, the said downlink signal transmission to that user is likely to cause significant interference to other mobile users of the network and, if not, of omitting the said step of identifying vulnerable users and of determining the said downlink beam pattern for the particular mobile user independently of the effect of that transmission on other mobile users of the network. Such a transmission method has the advantage that complex calculation is avoided when it is not needed.

20

25

In this embodiment, preferably, the said one or more predetermined criteria used in the interference judging step relate exclusively to the particular mobile user. In this way, it can be determined

30

35

desirably simply whether or not it will be worthwhile identify vulnerable users.

The predetermined criteria used in the interference judging step may, for example, include one  
5 or more of the following:

a measure of the distance of the said particular mobile user from the base station; and a bit rate of the said downlink signal transmission to the said particular mobile user. Such information is readily  
10 available in the base station.

In one embodiment, in the said interference judging step it is judged that significant interference to other users is likely when a measure of the distance of the said particular mobile user from the base  
15 station exceeds a predetermined threshold value. This basis for judging interference is desirably simple but is effective because when the particular mobile user under consideration is relatively far from the base station the downlink transmission power to that user  
20 tends to be high, giving rise to significant interference to other users.

Alternatively, or in addition, in the interference judging step it may be judged that significant interference to other users is likely when a bit rate of the said particular mobile user exceeds a  
25 predetermined threshold value. This basis for judging interference is again simple but highly effective.

In one embodiment, in the step of identifying vulnerable users it is determined whether a mobile user  
30 other than the said particular mobile user is to be treated as a vulnerable user in dependence upon one or more of the following criteria:

the direction of that other mobile user; a measure of the distance of that other mobile user from the base  
35 station; a bit rate of that other mobile user; and a proximity of that other mobile user to further mobile

users of the network. Such a transmission method has the advantage of making use of information readily available in the base station.

5 Preferably, candidate mobile users other than the said particular mobile user are ranked in order of vulnerability according to the said criteria used in the identifying vulnerable users step and, when the number of other users exceeds the number  $N_{\max}$  of nulls/low side lobes that it is possible to form in the said downlink beam pattern, the  $N_{\max}$  most vulnerable candidate users in the said order are selected as vulnerable users for determining the downlink beam pattern. Such a ranking process is advantageous in environments where there are large numbers of mobile users, and permits identification of the most vulnerable users in a systematic manner.

10 In one embodiment, in the identifying vulnerable users step it is determined whether there are any clusters of other users and, if so, the clusters are ranked according to the numbers of users therein. Again, when there are large numbers of users in various clusters, this step enables the most vulnerable users to be prioritised so as to achieve the best overall result in terms of interference reduction.

25 In one embodiment, vulnerable users that form a cluster are processed collectively as a vulnerable cluster and the downlink beam pattern determined for the said particular mobile user is such as to include such a null having a direction matching a direction of the said vulnerable cluster. Such a collective processing method can enable the number of users for whom potential interference is reduced to be maximised, even when the total number of users exceeds the maximum number of possible nulls that can be formed.

35 The direction of the said vulnerable cluster may be determined based on an average of the respective

directions of the individual vulnerable users making up the cluster concerned. This average is easily calculable.

5 In one embodiment, the said distance measure for a mobile user is, or is derived from, a transmission power determined by the base station for transmitting a downlink signal to the user concerned. Such a transmission method has the advantage that it makes use of information already available in the base station in  
10 many networks.

Alternatively, the said distance measure for a mobile user may be, or may be derived from, a code time offset of an uplink signal received by the base station from the mobile user concerned. Such a transmission  
15 method has the advantage that it makes use of information already available in the base station in some networks.

Alternatively, the said distance measure for a mobile user and/or the said direction of a mobile user  
20 may be derived from information obtained using a satellite-based global positioning system (GPS). Such a transmission method has the advantage that the distance measures derived can be calculated with a great degree of accuracy. Some networks already use  
25 such a GPS based location system for emergency purposes.

Alternatively, in another embodiment, the said distance measure for a mobile user and/or the direction of a mobile user is derived from information obtained  
30 using triangulation techniques involving at least three base stations of the said network. Such a transmission method has the advantage that the distance measures derived can be calculated with a great degree of accuracy.

35 According to a second aspect of the present invention there is provided transmission apparatus, for



use in a base station of a mobile communications network, comprising: identification means operable to identify, for a particular mobile user of the network, one or more other mobile users that are to be treated  
5 as vulnerable users potentially adversely affected by a downlink signal transmission from the base station to the particular mobile user; determining means operable to determine a downlink beam pattern including a main beam having a direction matching a direction of the  
10 particular mobile user and also including a null having a direction matching a direction of at least one of the said vulnerable users; and transmission means operable to transmit such a downlink signal to the said particular mobile user using the determined beam  
15 pattern.

Such a transmission apparatus can form a more intelligent transmission beam pattern comprising a peak and some nulls, the peak and the nulls being selected using user information available to the base station.

20 In one embodiment, the apparatus further includes user data register means operable to store, for each of a plurality of mobile users of the said network, one or more predetermined items of information about the user concerned for use by the identification means to  
25 identify vulnerable users and/or by the determining means to determine the downlink beam pattern.

Such an apparatus has the advantage that required information about mobile users is stored in a readily accessible means.

30 In this embodiment, preferably, the stored items of information about each user include one or more of the following types of information: the direction of the mobile user; a measure of the distance of the mobile user from the base station; a bit rate of the  
35 mobile user; a position of the mobile user; and cluster information as to proximity of the mobile user to other

mobile users of the network. Such types of information about users are easily obtainable in the base station.

According to a third aspect of the present invention there is provided a base station for use in a  
5 mobile communications network, which includes transmission apparatus embodying the aforesaid second aspect of the present invention.

Such a base station can form a more intelligent transmission beam pattern comprising a peak and some  
10 nulls, the peak and the nulls being selected using user information available to the base station.

According to a fourth aspect of the present invention there is provided an angle-of-arrival calculation method, for use in receiving apparatus that  
15 includes an antenna array having a plurality of antenna elements for sampling, at different respective locations in space, a wanted signal transmitted to the apparatus and that also includes an adaptive beamformer operable to process a set of receive signals, derived  
20 respectively from the antenna elements of the array, in accordance with a beam pattern determined by an adjustable weight vector, the weight vector being adjusted in use of the apparatus in response to changes in an angle-of-arrival of the wanted signal at the  
25 antenna array, which method includes the steps of: processing the said adjustable weight vector to determine an angle-of-arrival of the wanted signal at which the response of the adaptive beamformer has a peak; and outputting a measure of angle-of-arrival of  
30 the said wanted signal based on the determined angle of peak beamformer response.

Such an angle-of-arrival calculation method can estimate the angle of arrival of an uplink signal from the uplink beam pattern without complex calculation.

35 Preferably, the said processing step comprises: determining the uplink beam pattern corresponding to

the current value of the said adjustable weight vector;  
calculating the uplink beamformer gain at a plurality  
of different possible angles-of-arrival according to  
the said uplink beam pattern; and selecting the angle-  
of-arrival for which the uplink beamformer gain is the  
greatest.

Such an angle-of-arrival calculation method can  
estimate the angle of arrival of an uplink signal from  
the uplink beam pattern without complex calculation.

Reference will now be made, by way of example, to  
the accompanying drawings, in which:

Figure 1 is a block diagram of parts of a base  
station including transmission apparatus according to a  
first embodiment of the present invention;

Figure 2 is a block diagram of parts of a base  
station including transmission apparatus according to a  
second embodiment of the present invention;

Figure 3 is a flowchart illustrating an example of  
a transmission method for use in the apparatus of  
Figures 1 and 2;

Figure 4 is a flowchart of a process which may be  
used in a part of the apparatus of Figures 1 and 2;

Figure 5 is a flowchart of a second process which  
may be used in a part of the apparatus of Figures 1 and  
2;

Figure 6 is a flowchart of a third process which  
may be used in a part of the apparatus of Figures 1 and  
2; and

Figure 7 is a flowchart of a fourth process which  
may be used in a part of the apparatus of Figures 1 and  
2.

A transmission method embodying the present  
invention seeks to optimise the transmission pattern  
for a particular mobile station by taking into account  
information on the other mobile stations within the

system. In addition to forming a narrow beam in the direction of the desired user, nulls may also be placed in the direction of one or more other "vulnerable" users, i.e. users who are likely to be adversely affected by the downlink signal transmission to that desired user. The effect of this should be to reduce interference levels at these mobile units and hence improve the system's performance and capacity.

5  
10  
15  
In systems having very few active users it may be possible to take into account all other users when setting the downlink beam pattern for a particular user. However, in most practical systems the number of active users will far exceed the number of users for which nulls can be formed, so in a preferred embodiment of the present invention, certain criteria are used to determine which mobile units are the most vulnerable to interference, and hence should have nulls in their directions during downlink transmission.

20  
Alternatively, or in addition, certain criteria are used to determine whether the transmission to a given mobile unit is likely to cause interference and hence whether users vulnerable to interference need to be determined.

25  
30  
35  
For example, generally speaking, when a base station transmits a downlink signal to a mobile station far away from the base station it transmits using a higher power level than for a mobile station close to the base station. Therefore a transmission from the base station to a far-away mobile station will cause more interference than a transmission to a nearby one. Also, a nearby mobile station, to which the base station is transmitting its downlink signal at a relatively low power, will be particularly adversely affected by a high-power transmission from the base station to a far-away mobile station since the nearby mobile station experiences a low signal-to-

interference-and-noise ratio (SINR).

High-bit-rate (data rate) users are also more likely to cause and be affected by interference than low-bit-rate users. Therefore, in some types of system, for example a system with small cells that typically serve a large number of high-bit-rate users, bit rate could be used to select vulnerable users.

As an example, some of the following types of information about users might be used to determine vulnerable users: knowledge of the direction of arrival of signals from all users, knowledge of the relative distance of the users from the base station, knowledge of high-bit-rate users and knowledge of clusters of users.

In a base station in which beamforming is performed on the uplink, information about direction of arrival (DOA) of uplink signals from all the users within a given cell should be known to the base station.

Knowledge of the relative distance of users from the base station can be obtained using a number of methods. In one method, the relative distance from the base station of a given mobile unit can be estimated from a downlink transmission power determined for the mobile unit by the transmission power control (TPC) circuitry in the base station; the lower the transmitted power (TPC setting), the closer the mobile unit is assumed to be to the base station. As an alternative, code time offsets could be used to estimate the relative distances of the users from the base station.

Alternatively, a position location system may be used by the mobile communications system to obtain DOA and/or distance information for the users in the cell. This may involve a satellite-based global positioning system (GPS) or terrestrial triangulation techniques.

For example, if the uplink signal from a mobile station is received by three base stations, then its exact location, and therefore DOA and distance from any of the base stations, can be calculated.

5           Data identifying high-bit-rate users is readily available at the base station and information about clusters of users is easily determined from DOA information available at the base station.

10           It will be appreciated that in many systems the number of available nulls in the transmission beam pattern will be insufficient to permit nulls to cover the vulnerable users individually, but in this situation providing a null corresponding to a cluster of users can still enable the overall system  
15 performance and capacity to be improved.

          It should be noted that embodiments of the present invention are not restricted to the use of any one uplink beamforming technique.

20           Transmission apparatus according to a first embodiment of the present invention is illustrated in Figure 1, together with receiving apparatus capable of performing multibeam uplink beamforming.

          The receiving apparatus comprises a first array of antenna elements  $2_{11}$  to  $2_{14}$  connected via respective  
25 down-converters (not shown) to a multiple vector multiplier unit 4. The multiple vector multiplier unit 4 comprises M sets of complex-conjugate multipliers, where M (= 4 in this embodiment) is the number of different trial (uplink) beam patterns formed by the  
30 receiving apparatus. Each of the M sets of multipliers has N multipliers, where N (= 4 in this embodiment) is the number of antenna elements in the first array. Each of the M sets of multipliers has a corresponding  
35 uplink weight vector associated with it for defining the trial beam pattern with which it is to process the receive signals produced by the antenna elements  $2_{11}$  to

2<sub>14</sub>. It should be noted that the values of N and M do not have to be 4 and can be different from each other.

The multiple vector multiplier unit 4 is in turn connected, via a set of combiners 6<sub>1</sub> to 6<sub>4</sub>, to a beam selector 8.

The receiving apparatus also comprises receiver circuitry 10 connected to an output of the beam selector 8.

The transmission apparatus comprises a user data register (UDR) 14, an optimum weights computation unit 12 and a vulnerable users selection unit 16.

The UDR 14 has a plurality of data inputs connected to other parts of the base station for receiving therefrom data signals corresponding to each user. These data signals include a user DOA signal corresponding to each user produced by the beam selector 8 in the receiving apparatus. The user DOA signal for the desired user is also passed to the optimum weights computation unit 12. The vulnerable users selection unit 16 has an input connected to the UDR 14 and an output connected to the optimum weights computation unit 12.

The Figure 1 apparatus further comprises transmitter circuitry 18, a downlink beamformer 20 and a second array of antenna elements 2<sub>21</sub> to 2<sub>24</sub>. The downlink beamformer 20 comprises P complex-conjugate multipliers, where P (= 4 in this embodiment) is the number of antenna elements in the second array. P need not be the same as N, although this may be preferable for simplifying the processing required.

Each multiplier in the downlink beamformer 20 is connected to receive one of a set of P weight values, making up a weight vector, from the optimum weights computation unit 12 and is also connected to receive from the transmitter circuitry 18 data to be transmitted to the desired user. Each multiplier in

the downlink beamformer 20 produces a transmit signal, which is applied to a corresponding one of the antenna elements  $2_{21}$  to  $2_{24}$  of the second array.

5           Operation of the Figure 1 apparatus will now be described. In use, the multiple vector multiplier unit 4, the set of combiners  $6_1$  to  $6_4$ , and the beam selector 8 together serve as a multibeam uplink beamformer. To receive an uplink signal from a particular desired user each set of multipliers in the multiple weight vectors unit multiplies the receive signals, produced  
10           respectively by the first-array antenna elements  $2_{11}$  to  $2_{14}$ , by its associated uplink weight vector, each uplink weight vector corresponding to a different preselected trial uplink beam pattern. The uplink beam patterns  
15           have, for example, different beam directions covering a particular sector of the base station. The partial products of the multiplication are summed in the combiners  $6_1$  to  $6_4$  to produce output signals corresponding respectively to the trial beam patterns.  
20           The beam selector 8 compares the output signals and selects the best trial beam pattern for detecting the uplink signal from the present desired user. Alternatively, instead of selecting just one best beam pattern, the beam selector 8 may perform an  
25           interpolation operation to derive a further weight vector corresponding to a beam pattern having a direction between two or more comparably-good different trial beam patterns. The result of this selection/interpolation is output to the receiver  
30           circuitry 10, which uses the output signal for the best trial beam pattern directly to perform signal reception on the uplink signals from the desired user.

35           The beam selector 8 outputs a user DOA signal which, in this embodiment, simply provides the identity of the selected best uplink beam pattern or, if interpolation is used, the identities of the best



uplink beam patterns. This user DOA signal effectively defines an expected DOA of uplink signals from the particular desired user. This user DOA signal is output to the UDR 14 and the optimum weights computation unit 12 in the transmission apparatus.

The UDR 14 stores predetermined types of information about each user. In this embodiment, the UDR stores the DOA, the power level and the bit rate each user is operating at. This information is regularly updated for example, every frame, or every timeslot within a frame, or dynamically at intervals determined by operating parameters of the apparatus.

In the vulnerable users selection unit 16, the user information stored in the UDR 14 is used to determine one or more of the following: the DOA information for the desired user, users nearest to the base station, users who are close to clusters of other users, and users who are close to high bit rate users. Then, using suitable criteria, that information can be used to generate a list of vulnerable users associated with every user. Different examples of criteria which can be used to generate a list of vulnerable users will be described in detail hereinbelow with reference to Figures 4, 5, 6 and 7. It should be noted that the criteria used may be fixed or made dynamic and may vary depending on the particular environment or scenario. For example, in environments where there is a high proportion of high-bit-rate users or clusters of high-bit-rate users, the criteria for determining vulnerable users might advantageously be to minimise the adverse effect on/of these high-bit-rate users / user clusters. On the other hand, in cells whose range is extended, the distance between the users and the base station becomes an important criterion.

Once the list of vulnerable users associated with the desired user has been generated in the vulnerable

users selection unit 16, the DOA of each vulnerable user is output to the optimum weights computation unit 12.

5           The optimum weights computation unit 12 calculates  
a set of weights defining a downlink beam pattern which  
has its main lobe in the direction of the desired user  
and preferably has nulls in the directions of some or  
all of the most vulnerable users. It should be noted  
that however vulnerable the corresponding user, a null  
10       should not be placed in the main beam of the beam  
pattern as this would degrade the downlink beam  
pattern. It should also be noted that for an array of  
N elements, it is mathematically possible to form up to  
N-1 nulls. Therefore, in this embodiment in which  
15       there are 4 elements in the second array of antenna  
elements  $2_{21}$  to  $2_{24}$ , the maximum number of nulls which  
can be formed at any time is 3.

          Once the weights have been calculated by the  
optimum weights computation unit 12, these are  
20       multiplied, in the downlink beamformer 20, with the  
data to be transmitted to the desired user received  
from the transmitter circuitry 18. The resulting  
transmit signals are then transmitted via the second  
array of antenna elements  $2_{21}$  to  $2_{24}$ .

25           It will be appreciated that the first and second  
arrays of antenna elements in the Figure 1 base station  
do not have to be physically distinct. One physical  
array of antenna elements could serve, in any of, for  
example, a time-division-multiplexed, frequency-  
30       division-multiplexed or code-division-multiplexed  
fashion, both for uplink reception and downlink  
transmission purposes.

          Figure 2 is a block diagram illustrating parts of  
a base station according to a second embodiment of the  
35       present invention. In this embodiment, adaptive uplink  
beamforming is implemented. Components of the Figure 2

apparatus which correspond to components already described with reference to Figure 1 will be denoted by the same reference numerals.

5 In place of the multiple vector multiplier unit 4, the set of combiners  $6_1$  to  $6_4$  and the beam selector 8 used in the receiving apparatus of the first embodiment, receiving apparatus in the second embodiment comprises a vector multiplier 22, a combiner 24, an adaptive algorithm unit 26, and an adder 28.  
10 The vector multiplier 22 includes complex-conjugate multipliers equal in number to the antenna elements of the first array. The vector multiplier 22 has four signal inputs, corresponding respectively to the antenna elements  $2_{11}$  to  $2_{14}$ , and a weight vector input  
15 coupled to an output of the adaptive algorithm unit 26. The signal outputs of the vector multiplier 22 are coupled to respective inputs of the combiner 24. An output of the combiner 24 is connected both to the receiver circuitry 10 and to a positive input of the  
20 adder 28. The adder 28 also has a negative input at which it receives a reference signal. An error signal produced at an output of the adder 28 is coupled to an input of the adaptive algorithm unit 26. The adaptive algorithm unit 26 has further signal inputs connected  
25 to the first array of antenna elements  $2_{11}$  to  $2_{14}$ .

In the Figure 2 embodiment the transmission apparatus further comprises a DOA determining unit 30 having a weight vector input connected to the adaptive  
30 algorithm unit 26. A user DOA signal produced at an output of the DOA determining unit 30 is coupled to inputs of the UDR 14 and the optimum weights computation unit 12.

Operation of the Figure 2 apparatus will now be described. In use, the vector multiplier 22, the  
35 combiner 24, the adder 28 and the adaptive algorithm unit 26 together serve as an adaptive uplink

beamformer. In the vector multiplier 22 receive signals derived from the antenna elements  $2_{12}$  to  $2_{14}$  are multiplied by corresponding weights of a variable weight vector supplied by the adaptive algorithm unit 5 26. This variable weight vector defines an adaptable uplink beam pattern for use by the receiving apparatus to process the receive signals. The partial products output by the vector multiplier 22 are summed together by the first combiner 24 and the result is output to 10 the receiver circuitry 10 which performs signal detection. The output of the combiner 24 is compared with a reference signal using the adder 28. This reference signal is, for example, generated based on the received uplink signals after detection by the 15 receiver circuitry 10. The resulting error signal produced by the adder 28 is fed back to the adaptive algorithm unit 26 as an indication of how good the current weight vector is. The adaptive algorithm unit 26 uses an adaptive algorithm to update the variable 20 weight vector.

The updated weight vector is also output to the DOA determining unit 30. Assuming the adaptive algorithm used in the adaptive algorithm unit 26 is fairly stable, an estimate of the DOA of the desired 25 user can be derived from the weight vector corresponding to the uplink beam pattern determined for that user. This could be done, for example, by finding the peak of the uplink beam pattern (e.g. by calculating the uplink beamformer gain at different 30 DOAs and identifying the DOA for which the gain is the highest). This DOA estimate is stored at the UDR 14 in an entry therein corresponding to the desired user.

Figure 3 is a flowchart showing a sequence of steps for transmitting a downlink signal to one desired 35 user in an embodiment of the present invention.

In step S1, the last-known DOA of the desired user

is determined using data stored in the UDR in response to reception of a preceding uplink signal from that user.

5 Then, in step S2, it is determined whether there is a list of vulnerable users (vulnerable list) associated with the transmission to the desired user. Methods for producing such a vulnerable list will be described in detail with reference to Figures 4, 5, 6 and 7. If there is a vulnerable list associated with  
10 the transmission, then step S3 is executed. If, on the other hand, the vulnerable list is empty, control moves to step S6.

In step S3 any users in the vulnerable list for whom the provision of a null in the downlink beam  
15 pattern for the desired user would degrade that pattern unduly are removed from the vulnerable list. One possible way of doing this is to compare the DOA of each user in the vulnerable list with the DOA of the desired user. If the DOA of a user in the vulnerable  
20 list falls within a certain angular range of the DOA of the desired user, then a null corresponding to this vulnerable user would fall within a main beam of the downlink beam pattern. Such a null would degrade the transmission pattern and therefore this user should be  
25 removed from the vulnerable list. It will be noted that the required angular separation between the main beam and a null may be determined by the beam width of the main beam which can be calculated as a function of the number of elements and the inter-element spacing.  
30 In an embodiment of the present invention this might work out as approximately  $10^\circ$ .

Then, in step S4, it is determined whether there are any users left in the vulnerable list. If there are, control moves to step S5. If not, control moves  
35 to step S6.

In step S5, weights are computed (or suitable

weights are selected from amongst a set of predetermined weights) which will generate a downlink beam pattern comprising a main beam in the direction of the desired user and nulls in the directions of up to  
5 N-1 vulnerable users (where N is the number of antenna elements). If there are more than N-1 vulnerable users in the vulnerable list, the N-1 most vulnerable users can be selected. To this end, as described later with reference to Figures 4 to 7, the users in the  
10 vulnerable list are preferably sorted into descending order of vulnerability in the vulnerable users selection unit 16, and then the first N-1 users in the list are selected.

Any suitable technique or algorithm can be used to  
15 compute the appropriate weights based on the DOA information for the desired user and the vulnerable users. Examples of possible techniques can be found in a paper by B. Van Veen and K. Buckley entitled  
20 "Beamforming: a versatile approach to spatial filtering" IEEE ASSP Magazine, April 1988, pp. 4 - 24, and also in a book by J. Hudson entitled "Adaptive Array Principles" published by Peter Peregrinus Ltd, London, 1981. When calculating the weights, using one of these techniques, appropriate constraints are used  
25 to achieve a main beam directed at the desired user and some of the nulls in the directions of some of the most vulnerable users.

Theoretically, an N element array can generate up to N-1 nulls. However, the locations of the nulls have  
30 to be outside the main beam to prevent its distortion. The allowed locations of the nulls are dependent on the array resolution, which in turn is influenced by the number of elements in the antenna array.

As mentioned above, the required weights can  
35 alternatively be selected from a set of available weights. In this case it is possible to select, as

appropriate weights, weights which produce a downlink beam pattern whose natural nulls correspond to the DOAs of at least some of the vulnerable users without significantly mis-pointing the main beam.

5           In step S6, which is executed if the vulnerable list is empty, according to either step S2 or step S4, weights are selected or computed that produce a beam pattern having a main beam directed in the desired user's determined uplink DOA, without reference to  
10 other users.

          After each of steps S5 and S6, step S7 is executed. In step S7, data is transmitted to the desired user using the weights selected/computed according to step S5 or step S6.

15           Figures 4, 5, 6 and 7 are flowcharts illustrating how different criteria can be used for the selection of vulnerable users in the selection of vulnerable users unit 16 of Figures 1 and 2. The used criterion (criteria) will depend on the particular application  
20 and environment, and may change as the environment changes.

          In the examples of Figures 4, 5, 6 and 7, the vulnerable list for a particular desired user is constructed in two stages prior to a downlink signal  
25 transmission to that user.

          The first stage is to determine whether the downlink signal transmission concerned could cause excessive interference to other users. In this stage, based on certain criteria, a decision is made as to  
30 whether there could be some users who are vulnerable to the current transmission. If the decision in the first stage is that the transmission is unlikely to cause adverse effects to other users, then there is no need for any further processing and the vulnerable list = 0  
35 (i.e. is empty). However, if it is decided in the first stage that there could be other vulnerable users,

the second stage is to construct the vulnerable list, that is a list of users that could be adversely affected by the current transmission. Certain criteria, which may be the same or different from those used in the first stage, are used to determine the degree of vulnerability of every user to the transmission to the desired user, and the users considered vulnerable are listed in the vulnerable list in descending order of vulnerability.

Figure 4 is a flowchart illustrating distance-based selection of vulnerable users. This might be suitable for cells with large coverage areas where different mobile users could experience significantly different path losses.

In step S11 it is determined whether the distance from the base station to the desired user's mobile station is greater than a predetermined distance threshold. If it is not, the transmission to that mobile station is unlikely to adversely affect other users, since the transmission will be at a relatively low power, and control moves to step S13 in which the vulnerable list is set to an empty state (vulnerable list = 0) whereupon processing ends.

If the desired user's mobile station's distance from the base station is greater than the distance threshold, however, control moves to S12. In step S12, the vulnerable list is formed as a list of all other users sorted in ascending order of their distance to the base station.

Then, in step S14, any users in the vulnerable list which belong to a cluster (i.e. are located near one another) are identified. This could be done, for example, by comparing the distances and DOAs of the users in the vulnerable list. Entries in the list for those users which belong to a cluster are replaced by a "cluster" entry in the list that has its DOA set equal



to the mean DOA of cluster concerned. This makes it possible to form nulls in the respective DOAs of the clusters.

5 Figure 5 is a flowchart illustrating bit-rate based selection of vulnerable users. This might be suitable for small cells that typically serve a significant number of high data/bit rate users.

10 In step S21, it is determined whether the desired user is a high data rate user. The data rate a given user is operating at is readily available to the base station, so this can be done simply by setting a threshold data rate above which a user is considered to be a high data rate user.

15 If the user is not a high data rate user then control moves to step S23. In step S23 the vulnerable list is set to the empty state and processing ends.

20 If, however, the desired user is a high data rate user according to step S21 control moves to step S22. In step S22 it is determined whether there are any clusters of users. If there are not any clusters of users then control moves to step S23 where the vulnerable list is also set to the empty state.

25 In this embodiment only if there is a high bit rate user and there is at least one cluster of users, who may be but are not necessarily high-bit-rate users, then, in step S24 entries are made in the vulnerable list for the clusters in descending order of cluster sizes. As before, the entry for each cluster has its DOA set to the mean DOA of the users in the cluster  
30 concerned.

Figure 6 is a flowchart illustrating a combined bit rate and distance based selection of vulnerable users. This might be suitable for large cells with a large number of high bit rate users.

35 In step S31 it is determined whether the desired user is a high data rate user. If so, then control

moves to step S34. If not, then control moves to step S32.

5 In step S32 it is determined whether the distance from the base station to the desired user mobile is greater than a predetermined distance threshold. If it is, then, as in S31, control moves to step S34. If it is not, control moves to step S33.

10 Thus, in this embodiment it is decided to form a vulnerable list when the desired user is a high data rate user or further than the distance threshold from the base station.

15 In step S33, which is executed when the desired user is neither a high data rate user nor further from the base station than the distance threshold, the vulnerable list is set to the empty state and processing ends.

20 In step S34, in one implementation, the vulnerable list is set equal to a list of all other users sorted in ascending order of their distance from the base station. In another implementation, the vulnerable list is set equal to a list of all other users in descending order of their data rates. If desired, the users in the vulnerable list may be sorted according to a combination of the distance and data rate criteria.

25 Then, in step S35, entries for users in the vulnerable list that belong to a cluster are replaced by a cluster entry whose DOA is set equal to the mean DOA of the users in the cluster concerned.

30 Figure 7 is a flowchart illustrating a modification of the process of selecting vulnerable users according to Figure 6. Steps in the Figure 7 flowchart which correspond to steps already described with reference to Figure 6 will be denoted by the same reference numerals.

35 This modified selection process applies a weighting process to the desired user's data rate and

distance from the base station and combines the results of the weightings to form a measure of the desired user's potential adverse effect on other users. Weightings  $\alpha$  and  $\beta$  for a desired user could be calculated as follows:

5

$$\alpha = \frac{\text{Desired User's Data Rate}}{\text{Data Rate Threshold}} \quad (1)$$

$$\beta = \frac{\text{Desired User's Distance to Base Station}}{\text{Distance Threshold}} \quad (2)$$

10 In step S41, the weightings  $\alpha$  and  $\beta$  are summed and the measure  $\alpha+\beta$  is used to determine whether it is necessary to protect any vulnerable users from a downlink transmission to the desired user. The value of a threshold for the measure  $\alpha+\beta$  could be set  
15 appropriately at the base station. According to step S41, if the measure  $\alpha+\beta$  is greater than the threshold value then control moves to steps S34 and S35, which were described hereinbefore with reference to Figure 6. If the measure  $\alpha+\beta$  is less than the threshold value  
20 then control moves to step S33, which is also described hereinbefore with reference to Figure 6.

**CLAIMS:**

1. A transmission method, for use in a base station of a mobile communications network, including  
5 the steps of:

identifying, for a particular mobile user of the network, one or more other mobile users that are to be treated as vulnerable users potentially adversely affected by a downlink signal transmission from the  
10 base station to the particular mobile user;

determining a downlink beam pattern including a main beam having a direction matching a direction of the particular mobile user and also including a null having a direction matching a direction of at least one  
15 of the said vulnerable users; and

transmitting such a downlink signal to the said particular mobile user using the determined beam pattern.

2. A method as claimed in claim 1, wherein the said direction of the said particular mobile user and of the or each said vulnerable user is determined by processing an uplink signal received at the base station from the user concerned.  
20

3. A method as claimed in claim 1 or 2, wherein the said direction of the said particular mobile user and of the or each said vulnerable user is derived from an uplink beam pattern employed by the base station to process a received uplink signal from the user concerned.  
25

4. A method as claimed in claim 3, wherein the uplink beam pattern is adapted in use by the said base station; and  
an estimate of the direction of each said mobile user is derived from an adjustable weight vector  
35 corresponding to the uplink beam pattern determined for that user.

5. A method as claimed in any preceding claim, wherein, in the pattern determining step, any identified vulnerable user whose direction would require the said downlink beam pattern to include such a null within, or near to, the said main beam is ignored.

6. A method as claimed in any preceding claim, wherein the said downlink beam pattern is calculated based on the respective directions of the said particular mobile user and the or each said vulnerable user.

7. A method as claimed in any one of claims 1 to 5, wherein the determined downlink beam pattern is a best-matching downlink beam pattern selected from amongst a plurality of predetermined candidate downlink beam patterns.

8. A method as claimed in any preceding claim, further including an interference judging step of judging, for the said particular mobile user, whether, based on one or more predetermined criteria, the said downlink signal transmission to that user is likely to cause significant interference to other mobile users of the network and, if not, of omitting the said step of identifying vulnerable users and of determining the said downlink beam pattern for the particular mobile user independently of the effect of that transmission on other mobile users of the network.

9. A method as claimed in claim 8, wherein the said one or more predetermined criteria used in the interference judging step relate exclusively to the particular mobile user.

10. A method as claimed in claim 8 or 9, wherein the said predetermined criteria used in the interference judging step include one or more of the following:

a measure of the distance of the said particular mobile user from the base station; and a bit rate of the said downlink signal transmission to the said particular mobile user.

5           11. A method as claimed in any one of claims 8 to 10, wherein in the said interference judging step it is judged that significant interference to other users is likely when a measure of the distance of the said particular mobile user from the base station exceeds a  
10 predetermined threshold value.

          12. A method as claimed in any one of claims 8 to 11, wherein in the interference judging step it is judged that significant interference to other users is likely when a bit rate of the said particular mobile  
15 user exceeds a predetermined threshold value.

          13. A method as claimed in any preceding claim, wherein in the step of identifying vulnerable users it is determined whether a mobile user other than the said particular mobile user is to be treated as a vulnerable  
20 user in dependence upon one or more of the following criteria:

          the direction of that other mobile user, a measure of the distance of that other mobile user from the base station; a bit rate of that other mobile user; a bit  
25 rate of that other mobile user; and a proximity of that other mobile user to further mobile users of the network.

          14. A method as claimed in claim 13, wherein candidate mobile users other than the said particular  
30 mobile user are ranked in order of vulnerability according to the said criteria used in the identifying vulnerable users step and, when the number of other users exceeds the number  $N_{max}$  of nulls/low side lobes that it is possible to form in the said downlink beam  
35 pattern, the  $N_{max}$  most vulnerable candidate users in the said order are selected as vulnerable users for

determining the downlink beam pattern.

15       15. A method as claimed in any preceding claim,  
wherein in the identifying vulnerable users step it is  
determined whether there are any clusters of other  
5       users and, if so, the clusters are ranked according to  
the numbers of users therein.

10       16. A method as claimed in any preceding claim,  
wherein vulnerable users that form a cluster are  
processed collectively as a vulnerable cluster and the  
downlink beam pattern determined for the said  
10       particular mobile user is such as to include such a  
null having a direction matching a direction of the  
said vulnerable cluster.

15       17. A method as claimed in claim 16, wherein the  
direction of the said vulnerable cluster is determined  
based on an average of the respective directions of the  
individual vulnerable users making up the cluster  
concerned.

20       18. A method as claimed in claim 10 or 13,  
wherein the said distance measure for a mobile user is,  
or is derived from, a transmission power determined by  
the base station for transmitting a downlink signal to  
the user concerned.

25       19. A method as claimed in claim 10 or 13,  
wherein the said distance measure for a mobile user is,  
or is derived from, a code time offset of an uplink  
signal received by the base station from the mobile  
user concerned.

30       20. A method as claimed in claim 10 or 13,  
wherein the said distance measure for a mobile user  
and/or the said direction of a mobile user is derived  
from information obtained using a satellite-based  
global positioning system.

21. A method as claimed in claim 10 or 13,  
wherein the said distance measure for a mobile user  
and/or the direction of a mobile user is derived from  
information obtained using triangulation techniques  
5 involving at least three base stations of the said  
network.

22. Transmission apparatus, for use in a base  
station of a mobile communications network, comprising:  
identification means operable to identify, for a  
10 particular mobile user of the network, one or more  
other mobile users that are to be treated as vulnerable  
users potentially adversely affected by a downlink  
signal transmission from the base station to the  
particular mobile user;

15 determining means operable to determine a downlink  
beam pattern including a main beam having a direction  
matching a direction of the particular mobile user and  
also including a null having a direction matching a  
direction of at least one of the said vulnerable users;  
20 and

transmission means operable to transmit such a  
downlink signal to the said particular mobile user  
using the determined beam pattern.

23. Apparatus as claimed in claim 22, further  
25 including:

user data register means operable to store, for  
each of a plurality of mobile users of the said  
network, one or more predetermined items of information  
about the user concerned for use by the identification  
30 means to identify vulnerable users and/or by the  
determining means to determine the downlink beam  
pattern.



24. Apparatus as claimed in claim 23, wherein the stored items of information about each user include one or more of the following types of information: the direction of the mobile user; a measure of the distance of the mobile user from the base station; a bit rate of the mobile user; a position of the mobile user; and cluster information as to proximity of the mobile user to other mobile users of the network.

25. A base station for use in a mobile communications network, including transmission apparatus as claimed in any one of claims 22 or 24.

26. An angle-of-arrival calculation method, for use in receiving apparatus that includes an antenna array having a plurality of antenna elements for sampling, at different respective locations in space, a wanted signal transmitted to the apparatus and that also includes an adaptive beamformer operable to process a set of receive signals, derived respectively from the antenna elements of the array, in accordance with a beam pattern determined by an adjustable weight vector, the weight vector being adjusted in use of the apparatus in response to changes in an angle-of-arrival of the wanted signal at the antenna array, which method includes the steps of:

processing the said adjustable weight vector to determine an angle-of-arrival of the wanted signal at which the response of the adaptive beamformer has a peak; and

outputting a measure of angle-of-arrival of the said wanted signal based on the determined angle of peak beamformer response.

27. A method as claimed in claim 26, wherein the said processing step comprises:

determining the uplink beam pattern corresponding to the current value of the said adjustable weight vector;

calculating the uplink beamformer gain at a plurality of different possible angles-of-arrival according to the said uplink beam pattern; and

5 selecting the angle-of-arrival for which the uplink beamformer gain is the greatest.

28. A transmission method substantially as hereinbefore described with reference to the accompanying drawings.

10 29. Transmission apparatus substantially as hereinbefore described with reference to the accompanying drawings.

30. A base station substantially as hereinbefore described with reference to the accompanying drawings.

15 31. An angle-of-arrival calculation method substantially as hereinbefore described with reference to the accompanying drawings.



Application No: GB 9908839.5  
Claims searched: 1 to 25

Examiner: M J Billing  
Date of search: 16 September 1999

**Patents Act 1977  
Search Report under Section 17**

**Databases searched:**

UK Patent Office collections, including GB, EP, WO & US patent specifications, in:  
UK CI (Ed.Q): H1Q QFA, QFC, QFF, QFH; H4L LDLX, LDSG, LDSL, LECX, LFNX.  
Int CI (Ed.6): H01Q 1/24, 3/26, 3/30, 3/34, 3/36, 3/38, 3/40; H04Q 7/30, 7/36, 7/38.  
Other: ONLINE - EPODOC, WPI.

**Documents considered to be relevant:**

Category	Identity of document and relevant passage	Relevant to claims
X	GB2328800A (MOTOROLA) - Figs.2,3; page 4 line 1 to page 5 line 11	1,2,6,13, 22 at least
X	GB2318947A (MOTOROLA) - page 12 lines 9-20, page 13 lines 19-26, page 14 line 20 to page 15 line 28	1,2,6,13, 22 at least
X	GB2316807A (MATSUSHITA) - Figs.52,53; Abstract, page 18 lines 8-21, page 94 line 16 to page 97 line 7	1,2,6,13, 22 at least
X	GB2307142A (MOTOROLA) - page 5 lines 3-20, page 6 lines 8-18	1,2,13,21, 22 at least
X	EP0841827A2 (LUCENT) - page 6 lines 8-21, page 11 line 37 to page 18 line 22	1,2,6,13, 22 at least
X,E	WO99/22423A1 (ERICSSON) - Fig.3; page 5 lines 5-8, page 7 lines 9-27, page 9 lines 17-21	1,2,6,13, 22 at least
X	WO98/16077A2 (TERATECH) - page 13 lines 20-23, page 17 line 17 to page 18 line 7	1,2,6,13, 20,22 at least

X	Document indicating lack of novelty or inventive step	A	Document indicating technological background and/or state of the art.
Y	Document indicating lack of inventive step if combined with one or more other documents of same category.	P	Document published on or after the declared priority date but before the filing date of this invention.
&	Member of the same patent family	E	Patent document published on or after, but with priority date earlier than, the filing date of this application.



The  
Patent  
Office  
35



INVESTOR IN PEOPLE

Application No: GB 9908839.5  
Claims searched: 1 to 25

Examiner: M J Billing  
Date of search: 16 September 1999

Category	Identity of document and relevant passage	Relevant to claims
X	US5260968 (GARDNER) - column 6 lines 17-26, column 13 lines 3-44	1,2,6,13, 22 at least

X	Document indicating lack of novelty or inventive step	A	Document indicating technological background and/or state of the art.
Y	Document indicating lack of inventive step if combined with one or more other documents of same category.	P	Document published on or after the declared priority date but before the filing date of this invention.
&	Member of the same patent family	E	Patent document published on or after, but with priority date earlier than, the filing date of this application.

An Executive Agency of the Department of Trade and Industry

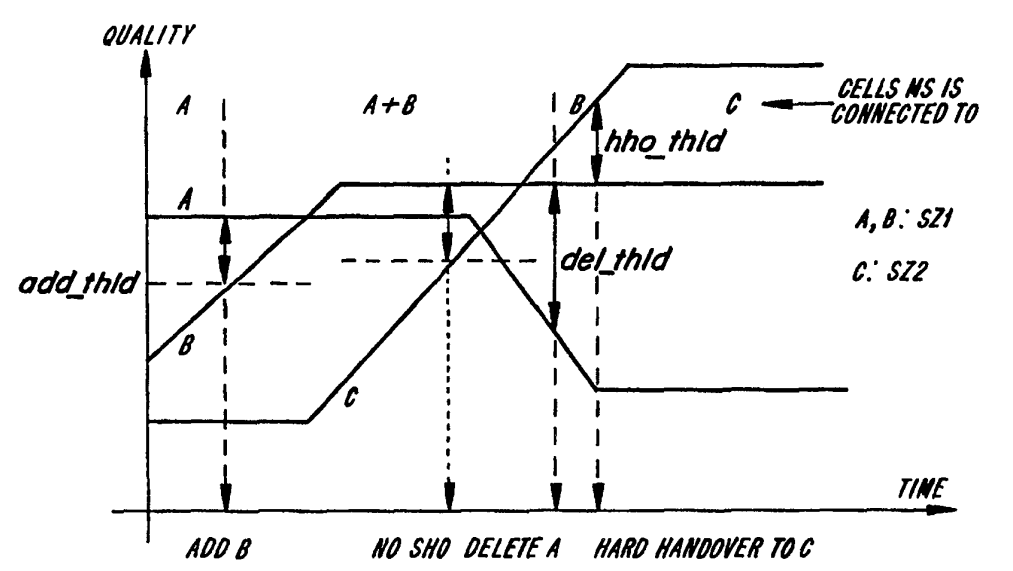


INTERNATIONAL APPLICATION PUBLISHED UNDER THE PATENT COOPERATION TREATY (PCT)

(51) International Patent Classification <sup>7</sup> : <b>H04Q 7/38</b>	<b>A1</b>	(11) International Publication Number: <b>WO 00/38455</b>
		(43) International Publication Date: 29 June 2000 (29.06.00)

<p>(21) International Application Number: PCT/EP99/10083</p> <p>(22) International Filing Date: 17 December 1999 (17.12.99)</p> <p>(30) Priority Data: PCT/IB98/02071 18 December 1998 (18.12.98) IB 09/461,030 15 December 1999 (15.12.99) US</p> <p>(71) Applicant: TELEFONAKTIEBOLAGET LM ERICSSON (publ) [SE/SE]; S-126 25 Stockholm (SE).</p> <p>(72) Inventors: JETZEK, Ulrich; Gerngrosstrasse 72, D-90409 Nürnberg (DE). BLOMBERG, Petter; Agatan 20, S-172 62 Sundbyberg (SE). JOHANSSON, Lars, B.; Torpparegatan 37, S-583 32 Linköping (SE). JONSSON, Sture; Sandviksgatan 78B, S-972 34 Lulea (SE). BUTOVITSCH, Peter; Domusu Yoyog-Uehara 3201, 3-17-15, Uehara, Shibuya-ku, Tokyo 150-0000 (JP).</p> <p>(74) Agent: MOHSLER, Gabriele; Ericsson Eurolab Deutschland GmbH, Ericsson Allee 1, D-52134 Herzogenrath (DE).</p>	<p>(81) Designated States: AE, AL, AM, AT, AU, AZ, BA, BB, BG, BR, BY, CA, CH, CN, CR, CU, CZ, DE, DK, DM, EE, ES, FI, GB, GD, GE, GH, GM, HR, HU, ID, IL, IN, IS, JP, KE, KG, KP, KR, KZ, LC, LK, LR, LS, LT, LU, LV, MA, MD, MG, MK, MN, MW, MX, NO, NZ, PL, PT, RO, RU, SD, SE, SG, SI, SK, SL, TJ, TM, TR, TT, UA, UG, UZ, VN, YU, ZA, ZW, ARIPO patent (GH, GM, KE, LS, MW, SD, SL, SZ, TZ, UG, ZW), Eurasian patent (AM, AZ, BY, KG, KZ, MD, RU, TJ, TM), European patent (AT, BE, CH, CY, DE, DK, ES, FI, FR, GB, GR, IE, IT, LU, MC, NL, PT, SE), OAPI patent (BF, BJ, CF, CG, CI, CM, GA, GN, GW, ML, MR, NE, SN, TD, TG).</p> <p><b>Published</b> <i>With international search report. Before the expiration of the time limit for amending the claims and to be republished in the event of the receipt of amendments.</i></p>
--	---

(54) Title: METHODS AND SYSTEMS FOR CONTROLLING HARD AND SOFT HANDOFFS IN RADIO COMMUNICATION SYSTEMS



(57) Abstract

A method, controller and system for controlling handoffs in radio communication systems using a softzone concept are described. Soft handoff is permitted between members of a particular softzone, but not between members of different softzones. Hard handoff is permitted between members of different softzones, but not between members of the same softzone.

**FOR THE PURPOSES OF INFORMATION ONLY**

Codes used to identify States party to the PCT on the front pages of pamphlets publishing international applications under the PCT.

<b>AL</b>	Albania	<b>ES</b>	Spain	<b>LS</b>	Lesotho	<b>SI</b>	Slovenia
<b>AM</b>	Armenia	<b>FI</b>	Finland	<b>LT</b>	Lithuania	<b>SK</b>	Slovakia
<b>AT</b>	Austria	<b>FR</b>	France	<b>LU</b>	Luxembourg	<b>SN</b>	Senegal
<b>AU</b>	Australia	<b>GA</b>	Gabon	<b>LV</b>	Latvia	<b>SZ</b>	Swaziland
<b>AZ</b>	Azerbaijan	<b>GB</b>	United Kingdom	<b>MC</b>	Monaco	<b>TD</b>	Chad
<b>BA</b>	Bosnia and Herzegovina	<b>GE</b>	Georgia	<b>MD</b>	Republic of Moldova	<b>TG</b>	Togo
<b>BB</b>	Barbados	<b>GH</b>	Ghana	<b>MG</b>	Madagascar	<b>TJ</b>	Tajikistan
<b>BE</b>	Belgium	<b>GN</b>	Guinea	<b>MK</b>	The former Yugoslav Republic of Macedonia	<b>TM</b>	Turkmenistan
<b>BF</b>	Burkina Faso	<b>GR</b>	Greece	<b>ML</b>	Mali	<b>TR</b>	Turkey
<b>BG</b>	Bulgaria	<b>HU</b>	Hungary	<b>MN</b>	Mongolia	<b>TT</b>	Trinidad and Tobago
<b>BJ</b>	Benin	<b>IE</b>	Ireland	<b>MR</b>	Mauritania	<b>UA</b>	Ukraine
<b>BR</b>	Brazil	<b>IL</b>	Israel	<b>MW</b>	Malawi	<b>UG</b>	Uganda
<b>BY</b>	Belarus	<b>IS</b>	Iceland	<b>MX</b>	Mexico	<b>US</b>	United States of America
<b>CA</b>	Canada	<b>IT</b>	Italy	<b>NE</b>	Niger	<b>UZ</b>	Uzbekistan
<b>CF</b>	Central African Republic	<b>JP</b>	Japan	<b>NL</b>	Netherlands	<b>VN</b>	Viet Nam
<b>CG</b>	Congo	<b>KE</b>	Kenya	<b>NO</b>	Norway	<b>YU</b>	Yugoslavia
<b>CH</b>	Switzerland	<b>KG</b>	Kyrgyzstan	<b>NZ</b>	New Zealand	<b>ZW</b>	Zimbabwe
<b>CI</b>	Côte d'Ivoire	<b>KP</b>	Democratic People's Republic of Korea	<b>PL</b>	Poland		
<b>CM</b>	Cameroon	<b>KR</b>	Republic of Korea	<b>PT</b>	Portugal		
<b>CN</b>	China	<b>KZ</b>	Kazakstan	<b>RO</b>	Romania		
<b>CU</b>	Cuba	<b>LC</b>	Saint Lucia	<b>RU</b>	Russian Federation		
<b>CZ</b>	Czech Republic	<b>LI</b>	Liechtenstein	<b>SD</b>	Sudan		
<b>DE</b>	Germany	<b>LK</b>	Sri Lanka	<b>SE</b>	Sweden		
<b>DK</b>	Denmark	<b>LR</b>	Liberia	<b>SG</b>	Singapore		
<b>EE</b>	Estonia						

**METHODS AND SYSTEMS FOR CONTROLLING HARD AND  
SOFT HANDOFFS IN RADIO COMMUNICATION SYSTEMS**

**BACKGROUND**

5           The present invention relates generally to methods and systems for radiocommunications and, more particularly, to such systems in which a connection can be handed over from one channel or base station to another.

          The cellular telephone industry has made phenomenal strides in commercial operations in the United States as well as the rest of the world. Growth in major  
10 metropolitan areas has far exceeded expectations and is rapidly outstripping system capacity. If this trend continues, the effects of this industry's growth will soon reach even the smallest markets. Innovative solutions are required to meet these increasing capacity needs as well as maintain high quality service and avoid rising prices.

15           In cellular systems, the capability is typically provided to transfer handling of a connection between, for example, a mobile station and a base station to another base station, as the mobile station changes its position and so moves out of the coverage area of one base station and into the coverage area of another base station. This type of handoff is commonly referred to as an "intercell" handoff as the  
20 coverage areas associated with base stations are commonly referred to as "cells". Depending upon the quality of the current channel, it may also be desirable to transfer a connection from one channel of the base station to another channel supported by the same base station, which handoffs are commonly referred to as "intracell" handoffs.

So-called "hard" handoffs refer to handoffs which are performed wherein there is no overlap in time between transmissions received from an original, serving base station and transmissions received from a new, target base station. As shown in Figure 1(a), during hard handoff, the mobile station (MS) typically first breaks its  
5 connection to its original base station (BTS1) and then establishes a connection to its new base station (BTS2).

By way of contrast, "soft" handoffs refer to handoffs wherein, for some period of time, a mobile station receives substantially the same information from two (or more) transmission sources. An exemplary soft handoff scenario is  
10 illustrated in Figure 1(b). Therein, before starting soft handoff, the MS is connected to BTS1. During the soft handoff, the MS establishes a connection to BTS2 without dropping the connection to BTS1. Each base station which is concurrently communicating with a particular mobile station may be referred to as a member of that mobile station's "active set". At some time after the connection to BTS2 is set  
15 up, the connection to BTS1 will be released which is the termination of the soft handover procedure. The overlapping transmissions from BTS1 and BTS2 permit the mobile station to smoothly switch from receiving information from its original, serving base station to receiving information from its new, target base station. During soft handoff, the mobile station may also take advantage of the fact that it is  
20 receiving substantially the same information from two sources to improve its received signal quality by performing diversity selection/combining of the two received signals.

For the sake of simplicity, the foregoing examples of the hard and soft handoff were described in the context of base stations employing omnidirectional  
25 antennas, i.e., wherein each base station transmits signals which propagate in a



substantially circular direction, i.e., 360 degrees. However, as will be appreciated by those skilled in the art, other antenna structures and transmission techniques may also be employed in radiocommunication systems. For example, a cell can be subdivided into several sectors, e.g., into three sectors where each sector covers a

5 120 degree angle as shown in Figure 2. Alternatively, the system or cell may employ an array antenna structure as shown in Figure 3. Therein, an exemplary radio communication system 200 includes a radio base station 220 employing a fixed-beam phased array (not shown). The phased array generates a plurality of fixed narrow beams ( $B_1, B_2, B_3, B_4$ , etc.) which radially extend from the base station

10 220, at least one of which ( $B_1$ ) is used to communicate with MS 210. Preferably, the beams overlap to create a contiguous coverage area to service a radio communication cell. Although not shown, the phased array can actually consist of three phased array sector antennas.

Of course, the principles described above with respect to hard and soft

15 handoff for omnidirectional antennas in Figures 1(a) and 1(b) can be directly mapped to other systems which employ sectorized and/or array antennas. In these latter types of systems, hard and soft handoffs can be performed between sectors or beams of the same base station as well as between sectors or beams associated with different base stations.

20 Both types of handoff have their drawbacks and advantages. On the one hand, soft handoff provides a robust mechanism for changing the connection from one base station to another. However, since the mobile station is connected to more than one base station during soft handoff, soft handoff requires more system resources than hard handoff. An advantage of hard handoff, therefore, is a reduced

need for system resources, while its drawback is a higher probability of dropped calls when compared to soft handoff.

Both hard and soft handoffs are employed in some radiocommunication systems. For example, Figure 4 illustrates a system described in WO 96/02117, wherein soft and hard handoff are applied sequentially. Therein, a system containing two base station controllers, BSC1 and BSC2, is shown. BSC1 controls base stations BTS11, BTS12 and BTS13, while BSC2 controls base stations BTS21, BTS22, and BTS23. The area that is served by all of the base stations coupled to a BSC is called a "BSC area".

10 Assume for this example, that the mobile station (MS) moves from cell A served by the base station BTS12 to cell B, which is at the border between two BSC areas. Cell B is served by two overlapping base stations, BTS11 and BTS21. BTS11 is coupled to controller BSC1, and BTS21 is coupled to base station controller BSC2. As the MS moves to cell B, it carries out a soft handoff controlled by BSC1 to a traffic channel of base station BTS11.

15 Assume further that the MS continues onward toward cell C and finally enters into its area of radiocommunication coverage. The base station BTS22, serving cell C, is under the control of BSC2. Before it is possible to activate the base station BTS22 for the handoff, the call control must first be switched to base station controller BSC2 from the previous controller BSC1. This is accomplished by performing a hard handoff. The MS performs a hard handoff from the base station BTS11 to the base station BTS21, and consequently, the base station controller change from BSC1 to BSC2 takes place. Finally, a soft handoff from BTS21 to BTS22 is performed.

However, these techniques described in WO 96/02117 do not provide a mechanism for controlling the use of either soft or hard handoff. Instead, these techniques are simply provided as an intended mechanism for reducing interference and signaling overhead associated with the handoff of a mobile area from a service area under the control of a first BSC to a service area under the control of a second BSC. Thus, these techniques do not provide any solution for controlling the usage of soft and hard handoff between cells *per se*.

According to European Patent Application 817 517 A1, as illustrated in Figure 5, a technique is presented for determining an appropriate type of handoff for a mobile station. In the Figure, the received perch channel (i.e., a type of broadcast control channel) level is shown for the cell where the MS resides initially (solid line) as well as for a neighboring cell (dashed line). The received levels are given with respect to the position of the mobile station.

According to EP 817 517 A1, the handoff type judgement method for a CDMA mobile communication system provides different types of handoff with different handoff start conditions. A type of handoff for which a handoff start condition is weakest, among the available types of handoff at a mobile station, is evaluated first. It is determined whether the handoff start condition for this type of handoff is satisfied or not at the mobile station. Each base station is notified for carrying out that type of handoff when the handoff start condition for that handoff is satisfied.

However, the techniques described in EP 817 517 A1 require that the mobile station be informed for each sector regarding which type of handoff is available. Hence out of a number of possible cells/sectors suitable for handoff with, possibly, different available handoff types, the mobile station first has to select all

cells/sectors that are available for the handoff type with weakest start condition. In a second step, a judgement among all of these cells/sectors will be performed. Thus, these techniques suffer from the drawbacks of having a two step procedure that requires intense signalling between the network (i.e., the base station) and the mobile station and that it is also quite complex to implement.

Accordingly, there is a need to develop enhanced techniques to determine when a handoff is appropriate, and which type of handoff is appropriate, to efficiently utilize system resources under different operating conditions.

10

#### SUMMARY

These, and other, problems, drawbacks, and limitations of conventional handoff techniques, are overcome according to the present invention in which a mechanism is provided for controlling the usage of soft and hard handoffs. According to exemplary embodiments of the present invention, methods and systems determine which handoff type is preferred at a specific location under current radio conditions. Another object of the present invention is to control hard and soft handoff while at the same time minimizing the overhead signalling between the network and the mobile station. Yet another object is to provide control methods and systems which are applicable to radiocommunication systems that use more than one frequency band to support communications in a cell/sector at the same time.

These, and other objects of the present invention are attained by a method for controlling handoff of a mobile station to a target transmission source in a radiocommunication system which comprises the steps of:

grouping a number of transmission sources into a group;

- assigning, to an active set associated with said mobile station, at least one transmission source from said group;
- selecting a first type of handoff to occur to at least one target transmission source if said at least one target transmission source is within said group; and
- 5 selecting a second type of handoff to occur to said at least one target transmission source if said first type of handoff is not selected.

In the method, a grouping of transmission sources (e.g., cells, sectors, base stations, beams or combinations thereof) is performed into groups which are denoted

10 as softzones. Each softzone has its own softzone identity. Softzone identities can be reused for sectors which are not too close to each other. All members in the active set have the same softzone identity. However, each transmission source may belong to multiple softzones, i.e. it is possible that a transmission source is assigned to different groups.

15 Softzone handoff mechanisms according to the present invention provide a number of benefits. For example, the overhead signalling between the mobile station and the network associated with controlling handoff type selection will be reduced as compared, for example, to the techniques described in EP 817 517 A1. This is due to the fact that cells/sectors are grouped into different softzones instead

20 of treating each cell/sector separately for the purpose of determining which type of handoff, if any, is appropriate. Moreover, these techniques provide a one-step procedure which permits great flexibility in the number of different handoff types that can be used.

Cell planners can use the softzone concepts described herein as a tool to take

25 into account that between certain cells hard handoff might be more reasonable while

between other cells a soft handover might be most suitable. Moreover, the grouping of transmission sources into particular softzones need not be static, e.g., a network operator may adjust softzone assignments based on changes to system structure (e.g., cell addition or cell splitting), changing load conditions, etc. Softzones can also be  
5 automatically regrouped by way of a dynamic regrouping algorithm, e.g., based on current network resources, air interface resources and loading patterns.

In a preferable embodiment of the method said first type of handoff is a soft handoff. In a soft handoff, at least one transmission source of the active set and at least one  
10 target transmission source in the handoff transmit substantially the same information to a mobile station at substantially the same time. The second type of handoff is preferably a hard handoff wherein a mobile station ceases receiving transmissions from one transmission source prior to receiving transmissions from a target transmission source. In an exemplary embodiment, soft handoffs may only be  
15 performed with transmission sources having the same softzone id as current members of the active set. Likewise, hard handoffs may only be performed to transmission sources having a different softzone id than current members of the active set.

20 Examples of suitable transmission sources include a cell, a base station, a frequency band, a beam associated with an antenna array and a sector. Preferably, the membership of transmission sources to a group can be readjusted.

A base station operating in a radiocommunication system can support  
25 communication on two or more different frequency bands. In this case, a suitable

choice of the groups is that transmission sources in a first frequency band supported by said base station are assigned to one group.

5 The step of selecting a type of handoff preferably comprises the step of measuring a quality level associated with transmission sources a group. The measured quality levels can then be evaluated in conjunction with at least one threshold. The membership in the active set of the mobile station can in this way be based on a result of the evaluating step. A preferable threshold can be adjusted. It can vary, for example, as a function of a quality level associated with a member of said active set.

10

Preferable quantities for the measurement of the quality level are for example the downlink signal-to-interference ratio, downlink received signal strength, downlink pathloss or downlink pathloss plus uplink interference. Combinations of different quantities can be used.

15

Preferably, group identifiers of transmission sources are transmitted to the mobile station.

20 A controller for controlling handoff of a mobile station to a target transmission source in a radiocommunication system comprises, according to the invention, preferably a processor selecting a soft handoff of a connection from at least one first transmission source, having a first group identification assigned thereto, to at least one second transmission source, having a second group identification assigned thereto, when said first and second group identifications are the same. A

25 transmission source can include for example one or more beams of an antenna array

or one or more sectors associated with one or more base stations. A hard handoff of said connection from one of the first transmission sources to one of the second transmission sources is selected when said first and second group identifications are different. It is possible that a transmission source is assigned to both said first and  
5 second groups.

In a preferable embodiment, the transmission sources comprise transceivers disposed within a same base station but which support communications on different frequency bands.

10

In a preferable embodiment, a processor in the controller can reassign a transmission source from a first group identification to another group identification. The processor can be identical to or different from the processor selecting the transmission device.

15

The controller can be disposed in a switch of the communication network. Switches are nodes in the network of the communication system for controlling connections like for example a BSC (base station controller) or an MSC (mobile switching center) according to GSM or UMTS specifications or an RNC (radio network  
20 controller). The controller can also be disposed in a mobile station.

A preferable radiocommunication system according to the invention comprises at least one first transmission source, having a first group identification assigned thereto and supporting a connection with a mobile station. A second transmission  
25 source has a second group identification assigned thereto. A processor associated



with a network controller, e.g. a switch, for controlling operations of the transmission sources and said mobile station selects a soft handoff of the connection from one of the first transmission sources to one of the second transmission sources when the group identifications are the same. When said first and second group  
5 identifications are different, a hard handoff of said connection from a first transmission source to a second transmission source is selected.

10

#### **BRIEF DESCRIPTION OF THE DRAWINGS**

The foregoing, and other, objects, features and advantages of the present invention will be more readily understood upon reading the following detailed description in conjunction with the drawings in which:

15 Figure 1(a) is an illustration of hard handoff;  
Figure 1(b) is an illustration of soft handoff;  
Figure 2 depicts a base station employing sector antennas;  
Figure 3 shows a base station employing an array antenna;  
Figure 4 is an illustration of a conventional technique for performing  
20 sequential hard and soft handoffs to handoff a connection involving two base station controllers;  
Figure 5 depicts another conventional technique for controlling different types of handoff;  
Figure 6 is a block diagram showing various functional blocks of an  
25 exemplary mobile station;

Figure 7 is a graph illustrating various handoff algorithm conditions for adding, deleting and replacing sectors;

Figure 8 shows three cells grouped into two softzones used to describe exemplary embodiments of the present invention; and

5 Figure 9 is a graph of measured quality versus time used to explain handoff techniques according to exemplary embodiments of the present invention.

### **DETAILED DESCRIPTION**

In the following description, for purposes of explanation and not limitation,  
10 specific details are set forth, such as particular circuits, circuit components, techniques, etc. in order to provide a thorough understanding of the invention. However it will be apparent to one skilled in the art that the present invention may be practiced in other embodiments that depart from these specific details. In other instances, detailed descriptions of well-known methods, devices, and circuits are  
15 omitted so as not to obscure the description of the present invention with unnecessary details. For example, although not described in detail herein, the present invention is applicable to radiocommunication systems which employ any type of access methodology, e.g., Frequency Division Multiple Access (FDMA), Time Division Multiple Access (TDMA), Code Division Multiple Access (CDMA),  
20 or any hybrid thereof.

Moreover, this specification describes techniques that are applicable to different types of handoffs. However, these techniques can be applied to handoffs from or to any transmission source, e.g., a cell, a base station, a sector, a beam, a transceiver, etc. Accordingly, although the term "cell" is used primarily herein to  
25 illustrate how handoff mechanisms according to the present invention operate, it will

be appreciated by those skilled in the art that these techniques apply equally to any type of transmission source.

Prior to describing the details of the present invention, an example of the construction of a mobile station which can operate to perform the signal quality measurements described above is illustrated in Figure 6. This block diagram has  
5 been simplified to illustrate only those components relevant to the measurement of downlink signal strength, however those skilled in the art will be well aware of the other major functional blocks associated with mobile stations. In Figure 6, incoming radio signals are received by transmitter/receiver TRX 500. The timing is  
10 synchronized to the received symbol sequence by microprocessor controller 530. The strength of the received signals are measured by a signal strength measuring part 520, the value of which is then passed to microprocessor controller 530. The bit error rate (BER) of the received signal can also be determined as an indication of received signal quality as reflected by block 540. This measurement of received  
15 signal quality is particularly relevant in determining when an intracell handoff is desirable. Of course, the present invention is applicable to systems which use any type of quality measurement parameter, e.g., signal-to-interference ratio, received signal strength or pathloss. The mobile station will also have input/output devices,  
20 such as a keyboard and display 535, as well as a microphone and speaker unit (not shown), which enables information to be exchanged between the mobile station and the base station.

When the mobile station receives a list of channel numbers, codes or other channel identifying information in a measurement command, it will measure the received signal quality associated with each of those channels. Once the mobile  
25 station has made the requested measurements, at least two different evaluation

techniques can be employed. First, if network evaluated handoff (NEHO) is employed, then the mobile station will report the measurements to the system which will then evaluate the various sectors using a handoff algorithm. Alternatively, if mobile evaluated handover (MEHO) is employed, then the mobile station itself will evaluate the various sectors.

An example is provided in Figure 7 to illustrate how the active set may change over time based on applying a handoff algorithm to these measurements. Taking as a given that there are four sectors (A,B,C,D) of interest in the handoff scenario of Figure 7, it is initially assumed that only sector A belongs to the active set. The measurement set in this example contains all sectors of the active set and all the neighbors of the active set, in this example A, B and C. Generally speaking, the measurement set contains all of the transmission sources for which the mobile station makes measurements. The measurement set typically includes all members of the active set, as well as transmission sources which are neighbors of the transmission sources in the active set. The measurement set is also typically defined by the network and periodically transmitted to the mobile station.

This exemplary handoff algorithm dictates that different handoff actions will be triggered according to the conditions stated below:

1. Add a sector: A sector X is added to the current active set if its quality  $Q_x$  meets the following condition:

$$Q_x > Q_{\text{best}} - \text{add\_th}$$

where  $Q_{\text{best}}$  represents the quality of the sector with the best quality in the Active Set and add\_th is a threshold value. For example, as shown in Figure 7, sector B is added to the active set at the time instant marked 'Add B' since the

difference between its quality level and the quality level received from sector A falls below add\_th. Note that after time 'Add B', sector D is added to the measurement set because it is a neighbor to sector B.

- 5           2.       Delete a sector: A sector X is deleted from the current active set if its quality  $Q_x$  meets the following condition:

$$Q_x < Q_{\text{best}} - \text{delete\_th}$$

where delete\_th represents the deletion threshold. An example of this condition occurring may be found at time instant marked 'Remove C' in Figure 7, wherein  
10       sector C is removed from the active set since the difference between its received quality level and that of sector B exceeds delete\_th.

3.       Replace a sector: The maximum number of cells allowed in the active set is limited. Once this maximum number is reached, the active set is said to  
15       be full. A sector X replaces the sector with the worst quality in the active set if the active set is full and the following condition holds:

$$Q_x > Q_{\text{worst}} + \text{replace\_th}$$

where replace\_th represents the threshold used for sector replacement. Provided that the maximum number of sectors in the active set is two in Figure 7, sector C should  
20       replace sector A at time instant marked 'Replace A with C' in Figure 7.

4.       Perform a hard handover: A hard handover from the current active set to a new sector is carried out if the quality  $Q_x$  of sector X fulfills the following condition:

25            $Q_x > Q_{\text{best}} + \text{hho\_th}$

where  $hho\_th$  represents the threshold used for hard handover, i.e., all connections of the current active set will be removed and a new connection to sector X will be set up. This is, for example, the case at the time instant marked 'hard handover to D' in Figure 7.

5           The actions described in this handoff algorithm to add, delete or replace a sector occur as soft handoffs in this example, unless the hard handoff threshold is exceeded in which case hard handoff takes precedence. However, according to exemplary embodiments of the present invention, additional control mechanisms are established to determine whether a soft or hard handoff is appropriate. More  
10 specifically, the present invention adopts an overlay mechanism referred to herein as a "softzone". The softzone is a group of cells, base stations or other transmission sources (e.g., sectors, beams, etc.) which can be identified by, for example, a softzone identification number (softzone id). Soft handoffs are then permitted only between members within the group having the same softzone id. The active set has  
15 a softzone identity which is referred to herein as the "active softzone identity". The softzone ids will be distributed from the network to the mobile station on either common or dedicated channels. Thus, the handoff rules described above with respect to Figure 7 are modified according to this exemplary embodiment such that:

- 20           1.       When the quality of a measured cell (base station, transmission source, beam, sector, etc.) exceeds the value  $Q_{best} - add\_th$  (the addition threshold), and the measured cell has a softzone identity which is identical to the active softzone identity, then the cell will be added to the active set in a soft handoff action. If the measured cell  
25 has a different softzone identity than the active set cells, the measured

cell will not be added to the active set, even though the quality of the measured cell exceeds  $Q_{\text{best}} - \text{add\_th}$ .

- 5           2.       When the quality of a measured cell (base station, transmission source, beam, sector, etc.) drops below the value of  $Q_{\text{best}} - \text{delete\_th}$  (the deletion threshold), and the measured cell belongs to the current active set, then the cell will be deleted from the current active set as part of a soft handoff operation.
  
- 10          3.       When the quality of a measured cell (base station, transmission source, beam, sector, etc.) exceeds the value of  $Q_{\text{best}} + \text{hho\_th}$  (the hard handover threshold), and the measured cell does not have a softzone identity which is identical to the active softzone identity, then a hard handoff will be performed to the measured cell. If the  
15           measured cell has the same softzone identity as the active set cells, no handoff action will be taken.
  
- 20          4.       When the quality of a measured cell (base station, transmission source, beam, sector, etc.) exceeds the value of  $Q_{\text{worst}} + \text{rpl\_th}$  (the replacement threshold), and the measured cell has a softzone identity which is identical to the active softzone identity, then the measured  
25           cell will replace the active set cell with the worst quality.

Of course, the softzone identities must be known in the mobile station (in the case of  
25   MEHO) or in the network (in the case of NEHO). Thus, in the former case, the

softzone identities will be transmitted to the mobile station beforehand. The values of the various handoff thresholds described herein may be fixed or may be variable with respect to, for example, the quality level of the best cell (base station, transmission source, beam, sector, etc.) in the active set.

5           An illustrative example is provided in Figures 8 and 9 to further explain softzone handoff concepts according to exemplary embodiments of the present invention. In Figure 8, three cells (A, B and C) are depicted that belong to two different softzones SZ1 and SZ2 and, therefore have different softzone ids. Initially, for this example, assume that a mobile station (not shown in Figure 8) is only  
10       connected to cell A. When the quality of cell B satisfies the condition to add a cell, i.e., at time instant "add B" in Figure 9, a connection to cell B is added, since cells A and B both belong to softzone SZ1. Although the quality of cell C exceeds the addition threshold as well, i.e., at time instant "no SHO" in Figure 9, cell C is not added by way of soft handoff since cell C has a different softzone identity than the  
15       current members of the active set A and B.

          After cell A has been deleted from the active set, i.e., at time instant "delete A" in Figure 9, the quality of cell C exceeds the hard handoff threshold. Thus a hard handoff will be performed that removes cell B from the active set and adds cell C thereto at time instant "hard handover to C" in Figure 9, since cell C belongs to  
20       softzone SZ2, while cell B belongs to softzone SZ1. Of course, if cells B and C had belonged to the same softzone, then no action would have been taken at time instant "hard handover to C" in Figure 9 because in this case cell c would have been added to the active set at time instant "no sho".

          Softzone handoff mechanisms according to the present invention provide a  
25       number of benefits. For example, the overhead signalling between the mobile



station and the network associated with controlling handoff type selection will be reduced as compared, for example, to the techniques described in EP 817 517 A1. This is due to the fact that cells/sectors are grouped into different softzones instead of treating each cell/sector separately for the purpose of determining which type of handoff, if any, is appropriate. Moreover, these techniques provide a one-step procedure which permits great flexibility in the number of different handoff types that can be used.

Cell planners can use the softzone concepts described herein as a tool to take into account that between certain cells hard handoff might be more reasonable while between other cells a soft handover might be most suitable. In rural areas, for example, line of sight links between mobile stations and base stations are rather frequent. Typically, even in case of hard handoff, a reliable handoff will be performed. On the other hand, in urban areas, line of sight links are rather rare. Furthermore, connection quality may be poor due to shadowing effects. For these reasons, a call is likely to get dropped during a hard handoff, thus creating a preference for soft handoff under these circumstances. In such a scenario, one softzone identity could be assigned to several adjacent urban cells while several different softzone identities could be assigned to rural cells.

Moreover, the grouping of transmission sources into particular softzones need not be static, e.g., a network operator may adjust softzone assignments based on changes to system structure (e.g., cell addition or cell splitting), changing load conditions, etc. Softzones can also be automatically regrouped by way of a dynamic regrouping algorithm, e.g., based on current network resources, air interface resources and loading patterns.

Further, it is anticipated that system capacity will most likely be increased by implementation of the present invention, since the present invention offers the possibility to control soft and hard handoff whereby efficient use of system resources is promoted.

5           The above-described exemplary embodiments are intended to be illustrative in all respects, rather than restrictive, of the present invention. For example, although the preceding exemplary embodiments do not reference multiple frequency bands, it will be apparent to those skilled in the art that the present invention is applicable to systems employing multiple frequency bands for communication and, 10 therefore, to either intrafrequency or interfrequency band handoff. Moreover, the same or different softzone ids may be provided for different frequency bands used by the same base station to provide communication services. Of course, for mobile stations having only a single receiver, i.e., which can only tune to a single frequency band at a given time, it would then be preferable to provide different softzone ids to 15 different frequency bands employed by a particular base station, i.e., to force hard handoffs rather than soft handoffs therebetween.

          Thus the present invention is capable of many variations in detailed implementation that can be derived from the description contained herein by a person skilled in the art. All such variations and modifications are considered to be 20 within the scope and spirit of the present invention as defined by the following claims.

CLAIMS

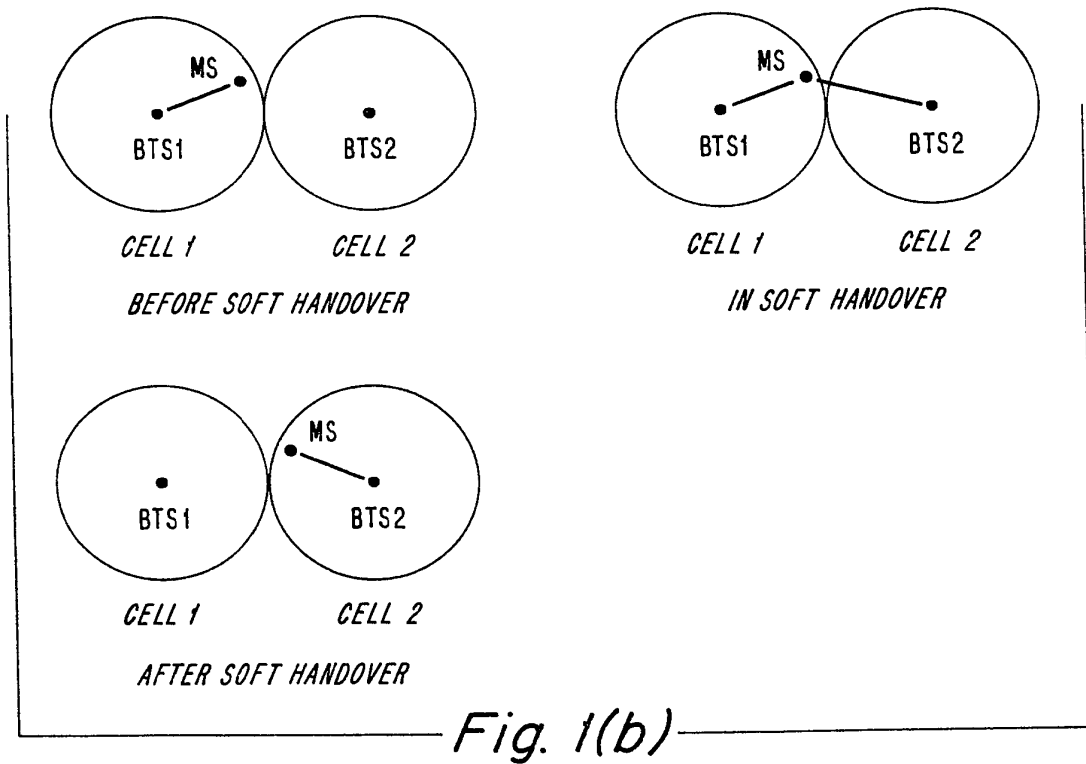
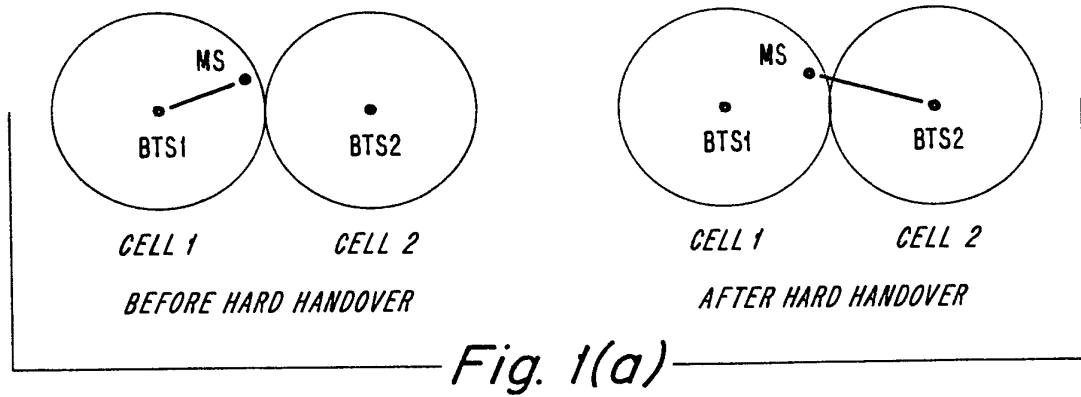
1. A method for controlling handoff of a mobile station to a target transmission source in a radiocommunication system comprising the steps of:  
5       grouping a number of transmission sources into a group;  
      assigning, to an active set associated with said mobile station, at least one transmission source from said group;  
      selecting a first type of handoff to occur to at least one target transmission source if said at least one target transmission source is within said group; and  
10       selecting a second type of handoff to occur to said at least one target transmission source if said first type of handoff is not selected.
2. Method according to claim 1, wherein said first type of handoff is soft handoff wherein said at least one transmission source of said active set and said at least  
15       one target transmission source transmit substantially the same information to said mobile station at substantially the same time.
3. Method according to claim 1 or 2, wherein said second type of handoff is hard handoff wherein said mobile station ceases receiving transmissions from said at  
20       least one transmission source prior to receiving transmissions from said at least one target transmission source.
4. Method according to any preceding claim, wherein said transmission sources  
25       include at least one of: a cell, a base station, a frequency band, a beam associated with an antenna array and a sector.

5. Method according to any preceding claim, further comprising the step of adjusting membership of transmission sources of said group.
- 5 6. Method according to any preceding claim, wherein a base station operating in said radiocommunication system supports communication on at least two different frequency bands and wherein said step of grouping further comprises: grouping a first frequency band associated with said base station in said group.
- 10 7. Method according to any preceding claim, wherein said step of selecting a first type of handoff further comprises the steps of:  
measuring a quality level associated with transmission sources in said group;  
evaluating said measured quality levels in conjunction with at least one  
threshold; and  
15 adjusting membership in said active set based on a result of said evaluating step.
8. Method according to claim 7, wherein said at least one threshold is variable.
9. Method according to claim 7 or 8, wherein said quality level is one of downlink  
20 signal-to-interference ratio, downlink received signal strength, downlink pathloss and downlink pathloss plus uplink interference.
10. Method according to claim 8 or 9, wherein said at least one threshold varies as a  
function of a quality level associated with a member of said active set.

25

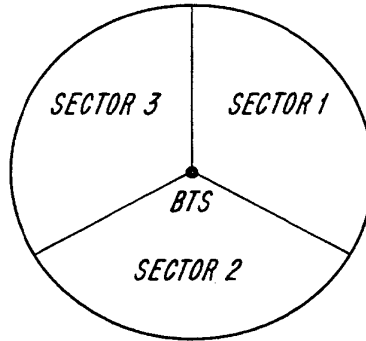
11. Method according to any preceding claim further comprising the step of distributing group identifiers of transmission sources to said mobile station.
12. Method according to any preceding claim, wherein at least one transmission  
5 source is assigned to different groups.
13. A controller for controlling handoff of a mobile station to a target transmission source in a radiocommunication system with a processor for:
- 10 - selecting a soft handoff of a connection from at least one first transmission source, having a first group identification assigned thereto, to at least one second transmission source, having a second group identification assigned thereto, when said first and second group identifications are the same; and
- 15 - selecting a hard handoff of said connection from said at least one first transmission source to said at least one second transmission source when said first and second group identifications are different.
14. Controller according to claim 13, wherein said at least one first and said at least one second transmission sources are transceivers disposed within a same base station but which support communications on different frequency bands.
- 20
15. Controller according to any of the claims 13 or 14, wherein a processor can reassign said at least one first transmission source from said first group identification to another group identification.

16. Controller according to any of the claims 13 to 15, wherein the controller is disposed in a mobile station.
17. Controller according to any of the claims 13 to 15, wherein said controller is disposed in a switch.
18. A radiocommunication system comprising:  
at least one first transmission source, having a first group identification assigned thereto and supporting a connection with a mobile station;  
at least one second transmission source, having a second group identification assigned thereto;  
a network controller for controlling operations of said at least one first and said at least one second transmission sources; and  
a processor, associated with one of said network controller and said mobile station for:  
- selecting a soft handoff of said connection from said at least one first transmission source to said at least one second transmission source when said first and second group identifications are the same; and  
- selecting a hard handoff of said connection from said at least one first transmission source to said at least one second transmission source when said first and second group identifications are different.

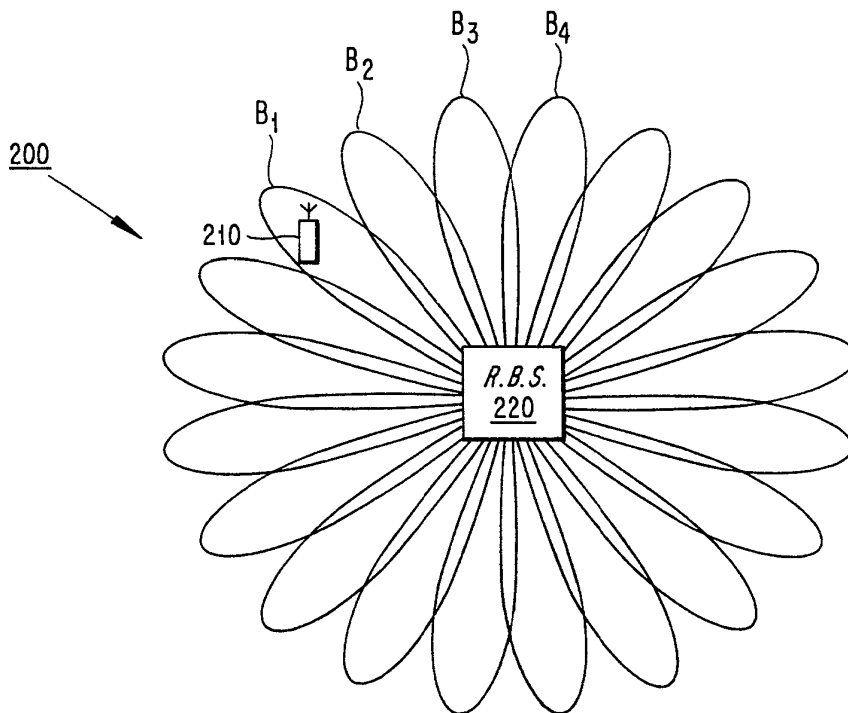


SUBSTITUTE SHEET (RULE 26)

2/5



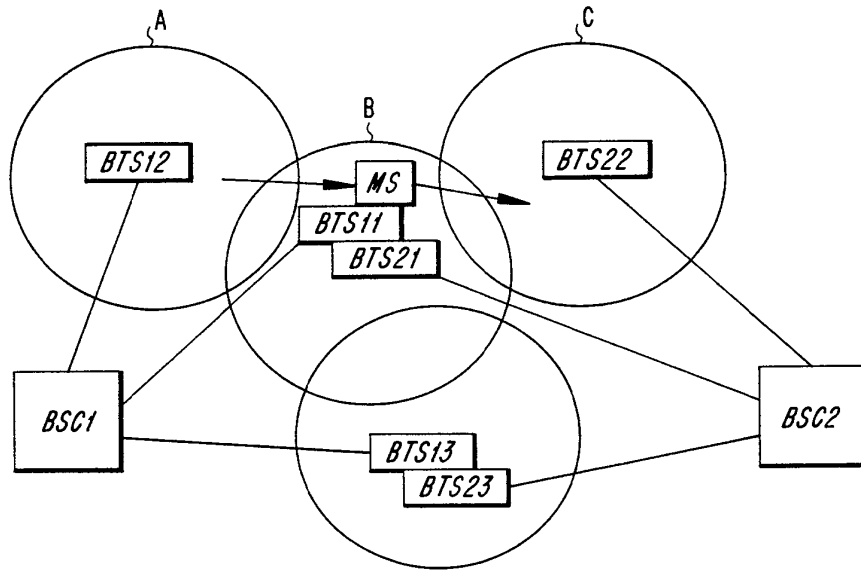
*Fig. 2*



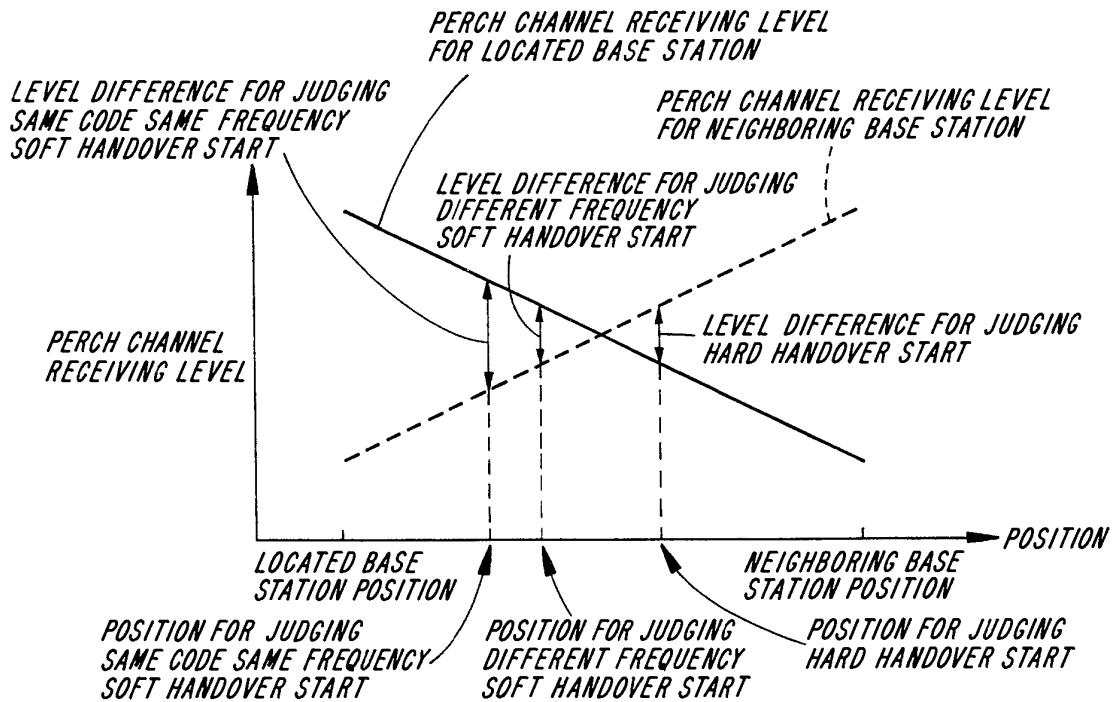
*Fig. 3*

SUBSTITUTE SHEET (RULE 26)





**Fig. 4**  
(PRIOR ART)



**Fig. 5**  
(PRIOR ART)  
SUBSTITUTE SHEET (RULE 26)

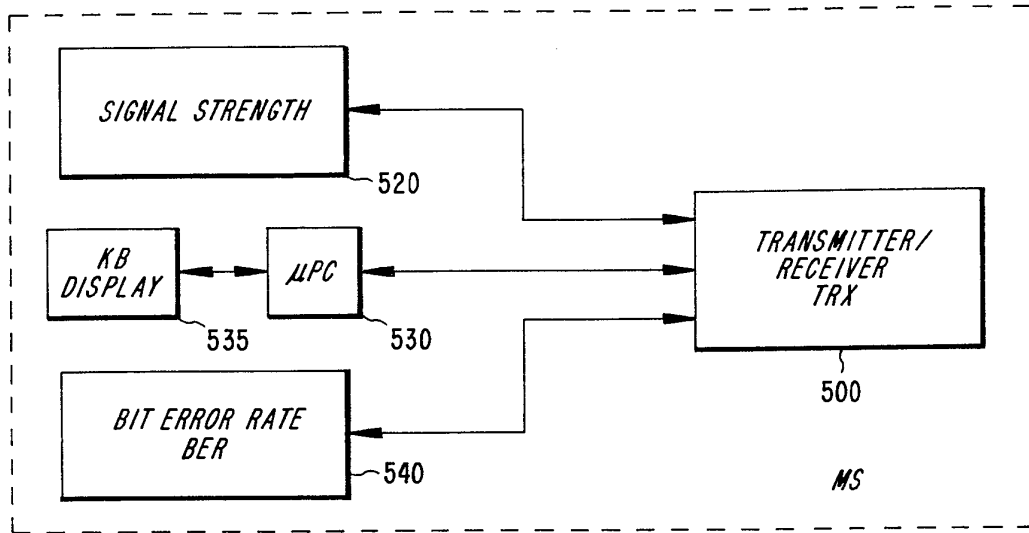


Fig. 6

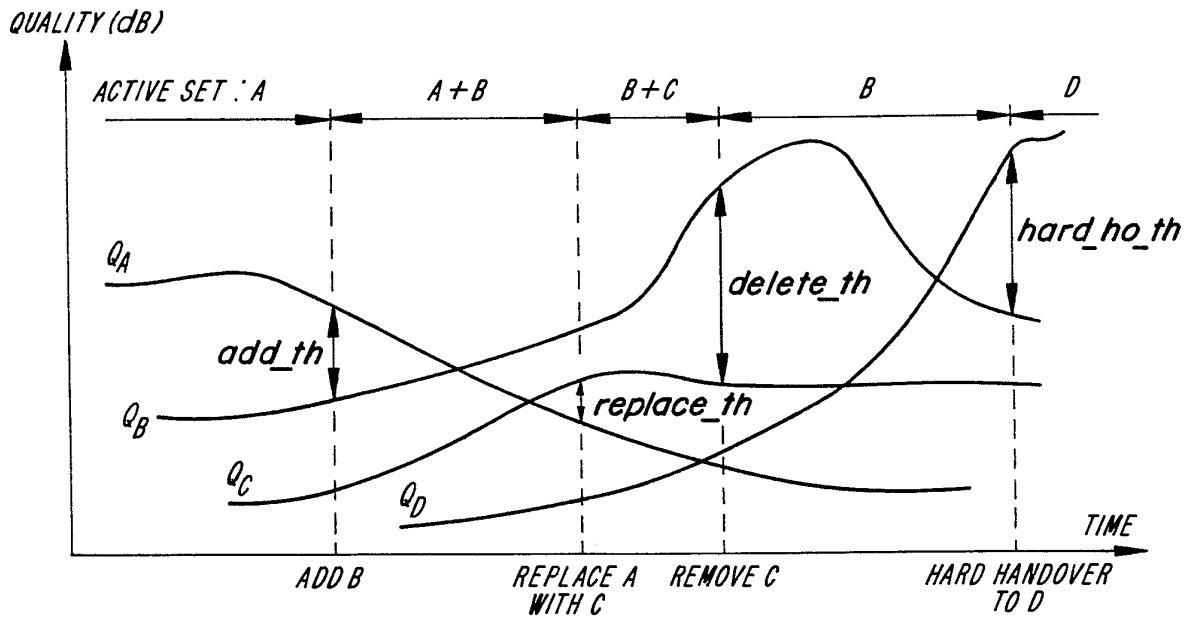


Fig. 7

SUBSTITUTE SHEET (RULE 26)

A, B: SOFTZONE SZ1  
C: SOFTZONE SZ2

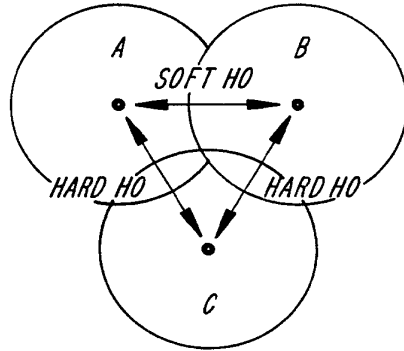


Fig. 8

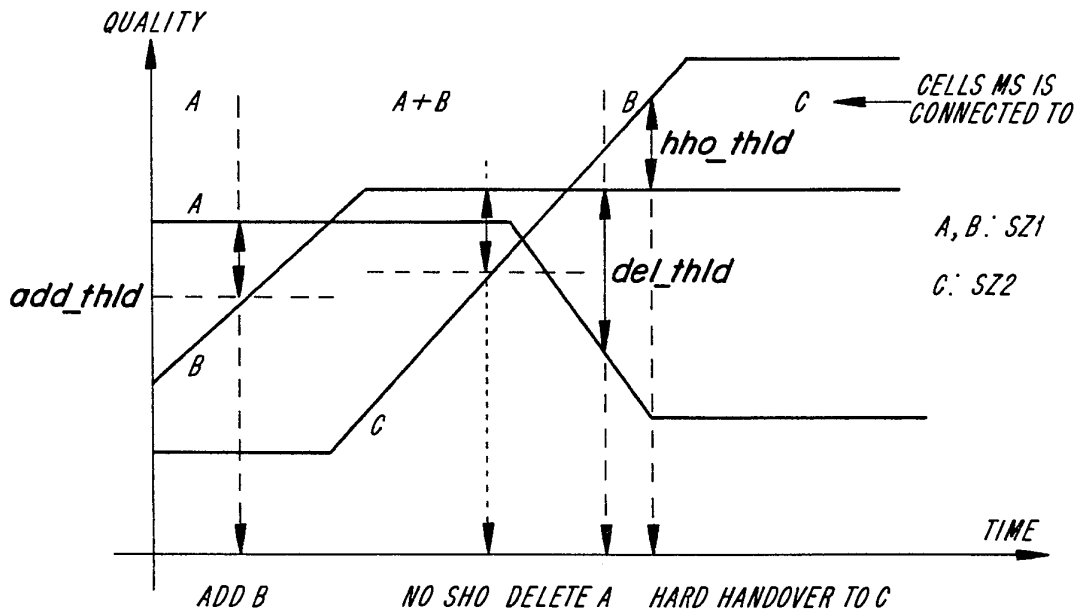


Fig. 9

SUBSTITUTE SHEET (RULE 26)

INTERNATIONAL SEARCH REPORT

International Application No  
PCT/EP 99/10083

<b>A. CLASSIFICATION OF SUBJECT MATTER</b> IPC 7 H04Q/38		
According to International Patent Classification (IPC) or to both national classification and IPC		
<b>B. FIELDS SEARCHED</b>		
Minimum documentation searched (classification system followed by classification symbols) IPC 7 H04Q		
Documentation searched other than minimum documentation to the extent that such documents are included in the fields searched		
Electronic data base consulted during the international search (name of data base and, where practical, search terms used)		
<b>C. DOCUMENTS CONSIDERED TO BE RELEVANT</b>		
Category *	Citation of document, with indication, where appropriate, of the relevant passages	Relevant to claim No.
X  A	WO 96 31078 A (QUALCOMM INC) 3 October 1996 (1996-10-03)  page 2, line 10 - line 17 page 6, line 32 - line 34 page 7, line 30 - line 37 page 9, line 29 - line 38 page 14, line 25 - line 33 -----	1-7, 9-11,13, 14,16-18 8,12,15
<input type="checkbox"/> Further documents are listed in the continuation of box C. <input checked="" type="checkbox"/> Patent family members are listed in annex.		
* Special categories of cited documents : "A" document defining the general state of the art which is not considered to be of particular relevance "E" earlier document but published on or after the international filing date "L" document which may throw doubts on priority claim(s) or which is cited to establish the publication date of another citation or other special reason (as specified) "O" document referring to an oral disclosure, use, exhibition or other means "P" document published prior to the international filing date but later than the priority date claimed "T" later document published after the international filing date or priority date and not in conflict with the application but cited to understand the principle or theory underlying the invention "X" document of particular relevance; the claimed invention cannot be considered novel or cannot be considered to involve an inventive step when the document is taken alone "Y" document of particular relevance; the claimed invention cannot be considered to involve an inventive step when the document is combined with one or more other such documents, such combination being obvious to a person skilled in the art. "&" document member of the same patent family		
Date of the actual completion of the international search  26 May 2000		Date of mailing of the international search report  07/06/2000
Name and mailing address of the ISA European Patent Office, P.B. 5818 Patentlaan 2 NL - 2280 HV Rijswijk Tel. (+31-70) 340-2040, Tx. 31 651 epo nl, Fax: (+31-70) 340-3016		Authorized officer  Janyszek, J-M

Form PCT/ISA/210 (second sheet) (July 1992)

# INTERNATIONAL SEARCH REPORT

Information on patent family members

International Application No <b>PCT/EP 99/10083</b>
--

Patent document cited in search report	Publication date	Patent family member(s)	Publication date
WO 9631078    A	03-10-1996	US    5594718 A	14-01-1997
		AU    697734 B	15-10-1998
		AU    5432396 A	16-10-1996
		BR    9607948 A	14-07-1998
		CA    2216635 A	03-10-1996
		EP    0818117 A	14-01-1998
-----			

Form PCT/ISA/210 (patent family annex) (July 1992)

(12) INTERNATIONAL APPLICATION PUBLISHED UNDER THE PATENT COOPERATION TREATY (PCT)

(19) World Intellectual Property Organization  
International Bureau



(43) International Publication Date  
15 August 2002 (15.08.2002)

PCT

(10) International Publication Number  
WO 02/063836 A2

- (51) International Patent Classification<sup>7</sup>: H04L 12/56
- (21) International Application Number: PCT/IB02/01219
- (22) International Filing Date: 8 February 2002 (08.02.2002)
- (25) Filing Language: English
- (26) Publication Language: English
- (30) Priority Data:  
0103274.7 9 February 2001 (09.02.2001) GB
- (71) Applicant (for all designated States except US): NOKIA CORPORATION [FI]; Keilalahdentie 4, FIN-02050 Espoo (FI).

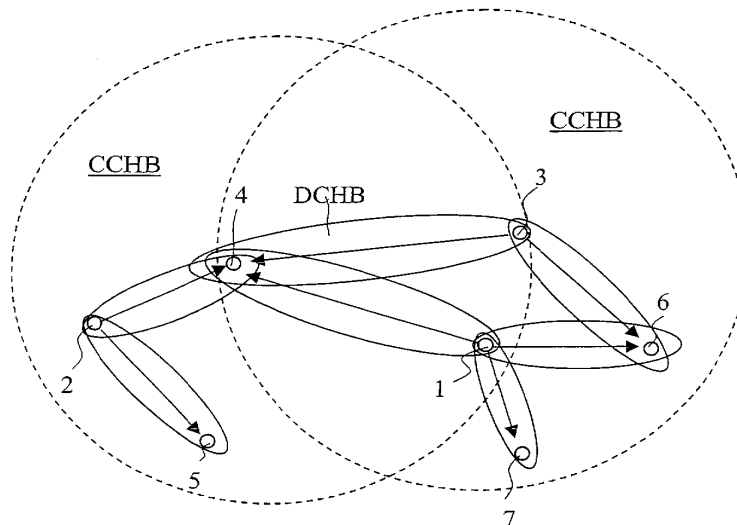
- (81) Designated States (national): AE, AG, AL, AM, AT, AU, AZ, BA, BB, BG, BR, BY, BZ, CA, CH, CN, CO, CR, CU, CZ, DE, DK, DM, DZ, EC, EE, ES, FI, GB, GD, GE, GH, GM, HR, HU, ID, IL, IN, IS, JP, KE, KG, KP, KR, KZ, LC, LK, LR, LS, LT, LU, LV, MA, MD, MG, MK, MN, MW, MX, MZ, NO, NZ, OM, PH, PL, PT, RO, RU, SD, SE, SG, SI, SK, SL, TJ, TM, TN, TR, TT, TZ, UA, UG, US, UZ, VN, YU, ZA, ZM, ZW.
- (84) Designated States (regional): ARIPO patent (GH, GM, KE, LS, MW, MZ, SD, SL, SZ, TZ, UG, ZM, ZW), Eurasian patent (AM, AZ, BY, KG, KZ, MD, RU, TJ, TM), European patent (AT, BE, CH, CY, DE, DK, ES, FI, FR, GB, GR, IE, IT, LU, MC, NL, PT, SE, TR), OAPI patent (BF, BJ, CF, CG, CI, CM, GA, GN, GQ, GW, ML, MR, NE, SN, TD, TG).

**Published:**  
— without international search report and to be republished upon receipt of that report

For two-letter codes and other abbreviations, refer to the "Guidance Notes on Codes and Abbreviations" appearing at the beginning of each regular issue of the PCT Gazette.

- (72) Inventor; and
- (75) Inventor/Applicant (for US only): ALASTALO, Ari [FI]; Alberganesplanadi 2 B 62, FIN-02600 Espoo (FI).
- (74) Agents: RUUSKANEN, Juha-Pekka et al.; Page White & Farrer, 54 Doughty Street, London WC1N 2LS (GB).

(54) Title: A DATA COMMUNICATION SYSTEM



(57) Abstract: A data communication system and a method for use in a data communication system is disclosed. The system comprises a plurality of nodes (1- 7) provided with means for wireless data communication. At least one directed wireless communication link (DCHB) can be formed between a node and another node for data communication. In the method control information is generated, said information associating with at least one node of the plurality of nodes. Said control information includes at least a capacity parameter that associates with the capacity of said at least one node. Data communications between the nodes are scheduled based on said control information and data is communicated between the nodes via said at least one directed link based on said scheduling.

WO 02/063836 A2

## A data communication system

### Field of the Invention

5 The present invention relates to a data communications system, and in particular, but not exclusively, to a system comprising at least two nodes that are capable of communicating with each other over an air interface. The nodes may be data communication network elements such as routers or access  
10 points.

### Background of the Invention

In a data communication system data may be transported between  
15 an originating i.e. transmitting node and a destination i.e. receiving node. A data transmission between the transmitting and receiving nodes may need to be transported via one or several intermediate nodes on the route between the transmitting and receiving nodes. In order to enable a  
20 transportation of the data to a correct destination address, a functionality referred to as routing is required. A node providing the routing function is referred to as a router. In the routing operation the data is typically routed i.e. directed either directly to the destination node or to another  
25 router node on the route towards the destination node.

Data communication systems enabling data transmission over an air i.e. wireless interface are known. An exemplifying wireless system is the so called wireless local area network  
30 (WLAN). The user terminals of a WLAN system are connected to access points of the WLAN via air interfaces. By means of this the WLAN provides mobility for the users thereof. However, the

price to capacity ratio of the present WLAN applications is not considered to be especially good.

In a wireless data communication system data can be transmitted over a wireless interface between two or more stations. The stations may be fixed or mobile stations. An example of the fixed station is a wireless router radio node. An example of the mobile station is a 3G mobile user equipment such as a third generation (3G) mobile telecommunications system mobile terminal. UMTS (Universal Mobile Telecommunication Service) is an example of the 3G standards.

The fixedly assembled components of a data network may also be in wireless communication with each other. For example, a router node may comprise a wireless IP (internet protocol) router, such as a wireless routing radio (WRR). A wireless router node may be based on use of time-division duplexing (TDD) together with time-division multiple access (TDMA).

In order to avoid a situation in which a wireless transmission causes interference to another transmission in the system and to ensure that the transmission can be received by the receiving station the transmissions need to be scheduled. The scheduling i.e. the order in which the neighbouring nodes may communicate on the radio channels can be based e.g. on the so called Neighbourhood Established Transmission Scheduling (NETS) scheme. The term 'neighbouring nodes' typically refers to those nodes in the neighbourhood of a node with which said one node can directly communicate with and with which said node has established neighbour relations. A node may choose that not all nodes that the node, at least in principle, could directly communicate with are its neighbours.



In the NETS scheme the nodes schedule their active radio links in the data channel such that various transmissions do not collide with each other and also such that the receiving station knows that it should receive data at a given moment of time in the future. For example, if a first node has reserved a time to transmit to a second node, the second node should prepare to receive at this time. Furthermore, all nodes that are located in the neighbourhoods of the first and second nodes should remain silent during the transmission in order to avoid interference.

In the conventional wireless data communication arrangements data is transmitted on a data channel by means of omnidirectional antenna arrangements. The omnidirectional transmission may cause substantial interference in all directions around the transmitting station. Thus it is especially important that all neighbouring stations remain silent during the transmission between the two stations.

Antenna arrays enabling directional transmission between two stations has been suggested in order to reduce the interference caused by omnidirectional antennae. Consequently a first node with a directional antenna should be allowed to transmit to a second node as long as the directional beam does not interfere with other active transmission links between other nodes. Directional beams can be used both for the reception and for the transmission.

A directional beam may be provided, for example, by means of so called switched beams or digital beam forming. The term 'smart antenna' is commonly use to refer to an antenna arrangement providing digital beam forming. However, the

inventor has found that the original NETS scheme does not optimally benefit from the use of directional beams.

The inventor has also found that it might be possible to  
5 increase the capacity of the wireless data communication system if the nodes could share at least a portion of the radio resources during the transmission and/or reception of data. That is, it could be advantageous if a node of the data communication system could communicate with at least two other  
10 nodes at the same time. It could be even more advantageous if the resources could be shared in both transmission and reception of data between the nodes.

#### Summary of the Invention

15

Embodiments of the present invention aim to address the problem related to the limited capacity of the prior art wireless data communication systems.

20 According to one aspect of the present invention, there is provided a method in a data communication system, said system comprising a plurality of nodes provided with means for wireless data communication, the method comprising: generating control information that associates with at least one node of  
25 the plurality of nodes, said control information including at least a capacity parameter associated with the capacity of said at least one node; scheduling data communications that associate with said at least one node at a given moment of time, said scheduling being based on said control information;  
30 forming a directed wireless data communication link between a node and another node; and communicating data between the nodes based on said scheduling.

According to another aspect of the present invention there is provided a data communication system comprising: a plurality of nodes, each of the nodes being provided with antenna means that are adapted to provide directed wireless data communication links with the others of the nodes; and means for communicating control information between the nodes, the control information including capacity information associated with at least one of the nodes, wherein the arrangement is such that data communications between the nodes over said directed communication links are scheduled based on said control information.

The embodiments may increase the capacity of a wireless data communication system. The capacity may be especially increased in embodiments where space division multiple access (SDMA) is used for the wireless data communication.

#### Brief Description of Drawings

For better understanding of the present invention, reference will now be made by way of example to the accompanying drawings in which:

Figure 1 shows a wireless data router system;

Figure 2 illustrates data communication between neighbouring nodes of a wireless data communication system;

Figure 3 shows a smart antenna arrangement;

Figure 4 is an example of the reservation of time slots for data communication in a frame; and

Figure 5 is a flowchart illustrating the operation of one embodiment of the present invention.

#### Description of Preferred Embodiments of the Invention

Reference is made to Figure 1 which shows a wireless data communication system comprising three wireless router nodes 1 to 3. The exemplifying router nodes are positioned on top of tall buildings 11. to 13 respectively. However, it shall be appreciated that manner how the router nodes are installed relative to the buildings is not an essential feature of the invention. A router node may be installed, for example, to the wall of a building, on the ground or on a specific construction designed solely for the purpose of supporting one or several router nodes. Each router node may comprise a wireless IP (internet protocol) router.

Each of the router nodes 1 to 3 is provided with transceiver means to enable wireless transmission and reception therebetween. The data transmissions at a given moment between the nodes 1 to 3 are indicated by the arrows between the nodes.

Although not shown for clarity reasons, a user terminal, such as a PC terminal or a mobile data processing device, may also have a wireless connection with a node providing an access point of the data network. The access point may be provided in one or all of the nodes 1 to 3 of Figure 1, or may be provided in a separate access node, such as a base transceiver station. A user terminal may also have a fixed connection to the routers. Furthermore, a user terminal may also provide a router.

Figure 2 is a schematic top view of a system that employs a plurality of wireless router nodes. The schematised wireless router node arrangement is shown to comprise seven nodes 1 to 7. The two circles drawn with dashed lines and designated by reference characters CCHB illustrate the substantially

omnidirectional control channel radiation patterns about nodes 3 and 4. It shall be appreciated that although all nodes may have substantially omnidirectional control channel radiation pattern or their own, only two control channel radiation patterns CCHB are shown for clarity reasons.

In accordance with the principles of the invention techniques the nodes are arranged to provide directional data communication between each other by means of directed data channel beams DCHB. The arrows between the nodes indicate the direction of data transmissions between the various neighbouring nodes occurring in a given moment of time.

It shall be appreciated that the Figure 2 illustration applies only for a given radio propagation environment. The number and shape of the radiation beams DCHB for the data transmissions that are directed towards the indented receiving neighbouring nodes will depend on the application and the environment.

More particularly, in a given moment of time (such as in a given single timeslot of a TDMA system) node 1 is shown to transmit to three different nodes 4, 6 and 7 at a same timeslot. Nodes 2 and 3 each transmit to two different nodes such that node 2 transmits to nodes 4 and 5 and node 3 transmits to nodes 4 and 6. Thus node 4 receives from three nodes, i.e. from nodes 1, 2 and 3. Node 6 receives from two nodes, i.e. from 1 and 3. Nodes 5 and 7 receive from one node only, i.e. from nodes 2 and 1, respectively.

At least some of the wireless router nodes 1 to 7 is provided with antenna means that are adapted to direct the transmission to a desired location. Alternatively, or additionally, at least some of the wireless router nodes 1 to 7 is provided

with antenna means that are adapted to direct the reception thereof towards a desired location. The directed transmission and/or reception may be provided by means of the directional transmission and reception beams. In a typical directive  
5 reception arrangement power received from a desired location is maximised.

A directional transmission or reception beam may be provided by a so called smart antenna arrangement. A smart antenna  
10 arrangement may provide a number of transmission and reception branches. A smart antenna system may be analogue or digital. The term smart antenna arrangement can typically, but not always, be understood to refer to an arrangement comprising  
15 the physical antennas, means to weight the transmissions and receptions corresponding to the different antennas and an algorithm or method to obtain proper antenna weights.

Figure 3 is a schematic illustration of a smart antenna arrangement 30 comprising four transmission branches. Each of  
20 the branches is preferably capable of serving the entire coverage area of the transceiver. A transmission branch may comprise an antenna element 15, a power amplifier 20 and digital or analogue circuitry 21 required to generate the signal to be transmitted by the antenna element 15. The  
25 antenna element 15 may be mounted on a mounting rack or similar mounting means 16.

An appropriate control equipment housing may also be provided. The housing may comprise a rack 18 for receiving the amplifier  
30 20 and other circuitry 21 that may be required for the generation of the directed beam. The control instrument housing is preferably located such that it is readily accessible for maintenance and upgrade operations. In a

preferred embodiment the antenna elements 15 are located as high as possible while the housing is located on the ground or the roof or elsewhere such that an easy access for maintenance and/or upgrade purposes is enabled. The element 15 and the equipment in the housing are connected by means of appropriate cabling 19.

The beams i.e. radiation patterns produced by the array arrangement 30 can be shaped to have a narrower or broader radio coverage. Digital beamforming (DBF) can be advantageously employed in the provision of the directional beams. Advantages may be obtained since the digital beamforming enables tuning of the radiation pattern of an antenna array to have a desired shape. By mean of the desired shape the radiation pattern can be directed to point to a selected direction. In a typical digital beamforming implementation each branch is connected to an antenna element or antenna element polarisation port.

In the digital beamforming the transmission radiation pattern (beam) may be formed at the baseband by means of appropriate phasing and amplitude of the signal in each transmission branch. This may be accomplished by multiplying the complex digital samples in each transmission branch with a complex weight factor. The set of weight factors (one factor for each branch) is called the weight vector. A different weight vector may be used for transmission and reception. The digital beam forming enables provision of different number of transmission and reception beams.

In an analogue fixed beam implementation the beam may be formed e.g. by an analogue Butler matrix permanently connected to an antenna array. Thus when the same array is used for the

transmission and reception, the number of transmission and reception beams will be the same. For example, antenna means may provide eight directional reception and transmissions beams. In other words, in an analogue implementation a  
5 transmission branch produces a fixed transmission beam covering a geographical coverage area on which the transmitter may transmit to another station within the beam coverage area.

In both the analogue and digital implementations a greater  
10 number of branches typically provides a better capacity. The beams can be made narrower and thus the area served by a beam can be made smaller and pointed more precisely towards the counterpart in the communication.

15 The data transmissions between the nodes are preferably based on time-division multiple access (TDMA) together with space division multiple access (SDMA) technique and on time division duplexing (TDD). The relation between the TDMA and SDMA schemes is such that the TDMA defines the allocation of time  
20 slots for transmissions whereas the SDMA defines allocation of transmission resources within a time slot allocated based on the TDMA. In other words, SDMA enables division of a TDMA time slot so that data associated with more than one data transmission may be carried by means of said single time slot.

25

Both the transmitting and receiving stations are capable of operating in accordance with the SDMA scheme. The use of space division multiple access is advantageous since it can be used to increase the capacity of the data network. In the  
30 embodiments based on use of the SDMA advantages are especially obtained if control information that associates with smart-antennas of the nodes is shared between the router nodes of the system.



The control information may comprise several different parameters that may be used in the scheduling. The control information includes at least capacity parameter of a receiving node. If transmissions to more than one node are scheduled at the same time, the control information may include appropriate information by means of which it is possible to separate the nodes from each other.

10 The scheduling is distributed in the nodes. Each of the nodes may determine, e.g. based on a medium access control (MAC) address, when it is time to transmit on the control channel. That is, each node is allocated with a slot on the control channel.

15 In systems such as the space division multiple access (SDMA) the separation can be based on so called spatial signatures of the nodes, the spatial signatures describing the spatial characteristics of the respective radio channels between the neighbouring nodes. That is, nodes that are served in the same timeslot can be separated from each other based on their individual spatial signatures.

25 The spatial signatures of the neighbouring nodes are usually estimated based on training signals that have been sent by the nodes. Each node estimates the spatial signatures (with respect to itself) of all those other nodes that are located in its neighbourhood. The estimation may be based on continuous monitoring of the transmissions by the neighbouring nodes. Methods to obtain the SDMA weights for smart-antenna combining in transmission and reception are known and will thus not be explained in full detail. However, an example of a

possible method for the spatial signature determination will be given later.

In the embodiments of the present invention the maximum number of simultaneous communications (transmissions and receptions) a router node can handle is defined by a specific parameter. This parameter will be referred to in the following as capacity parameter and occasionally, where more appropriate, also as  $C_{SDMA}^N$  value. In  $C_{SDMA}^N$  the character 'N' labels the particular node.

The capacity parameter typically depends on the number of antenna elements that are used for forming the beams. In theory, N antenna elements can handle N-1 independent beams. In practice the capacity parameter may be smaller than N-1 depending e.g. on the radio propagation environment, interference and so on.

In the embodiments the capacity parameter is communicated to the neighbouring nodes. The communication occurs, for example, over a control channel between the nodes. However, it is not necessary to communicate the capacity parameter in each control-channel message since in a typical application the value of the capacity parameter is not likely to change very often.

The control channel transmissions are preferably arranged to be based on non-directional transmission and reception patterns. For example, as shown by Figure 2, the control channel radiation patterns CCHB may have substantially omnidirectional shape about the nodes. That is, all the nodes in the neighbourhood of a node should receive the control-channel information regardless the directional location of the

nodes. The data channel is made feasible for the operation of the smart-antenna arrangement providing directional beams, as described above.

5 The following describes how the control channel information may be employed in the SDMA data transmission scheduling. It is assumed in the following that each node is provided with information regarding the values of the capacity parameters of its neighbours. The following description assumes also that  
10 node 1 is provided with a timeslot on the control channel of the current frame. In this timeslot the node 1 specifies those nodes to which it will transmit data on the current frame and/or from which it will receive data on the current frame. The node 1 may also specify this for at least some of the  
15 future frames. These reservations will be referred to in this specification as active links.

The following will describe also several other parameters that can be included in the control information, such as parameters  
20 associated with transmit and receive directivities. However, information that is not likely to change, such as the transmit and receive directivities, or changes only rarely, is preferably not included in every control channel transmission.

25 The start times and duration of the active links may also be specified in the reservations. Node 1 may base the decisions regarding the timeslots for its active links on information it has received from the other nodes about their forthcoming transmissions during the earlier control channel timeslots to  
30 avoid collisions. In order to enable the scheduling operations the nodes are adapted to interpret the received control channel information to decide in which time slots they can

perform their transmissions and in which time slots they should be prepared to receive.

As explained above, e.g. in the conventional Neighbourhood  
5 Established Transmission Scheduling (NETS) scheme the nodes try to schedule their active links such that none of the transmissions collides with another transmission. For example, if the node 1 has reserved a time to transmit to node 2 in accordance with the NETS, all the nodes in the neighbourhoods  
10 of nodes 1 and 2 shall remain silent during this transmission in order not to cause interference.

The embodiments enable use of a scheduling scheme that is not as rigid as e.g. the conventional NETS. In this context the  
15 SDMA is advantageous since it enables simultaneous transmission and/or reception to and/or from several different nodes. The transmission and/or reception may occur simultaneously in common timeslots.

20 A simultaneous communication with several nodes may be accomplished if a node is capable of handling more than one reception simultaneously, that is if  $C_{SDMA}^N > 1$  and if the node can separate the data in the incoming signals. Generally, a node is allowed to schedule a transmission to another node at  
25 time T if the number of already scheduled simultaneous transmission to said other node during that time is less than the  $C_{SDMA}^N$  value of said other node.

The use of the directional beams and the SDMA based allocation  
30 of the transmission resources enables the scheduling rule for the neighbouring nodes to be such that it is not necessary for the neighbouring nodes to be silent. The directional beams may be implemented, for example, by the above discussed switched

beams or digital beam forming. In addition, this also makes it possible to transmit to such nodes that are also in communication with other nodes.

5 Figure 2 exemplifies a situation in which a number of transmissions and receptions occur simultaneously in a wireless IP network that utilises an access technique such as the SDMA. As mentioned above, the SDMA enables the neighbours to transmit also to nodes that are in the process of  
10 transmitting to and/or receiving from other nodes.

The principle of the scheduling within a time slot is illustrated by Figure 4. Nodes 1, 2 and 3 are shown to transmit to a plurality of nodes during slot t1. Nodes 5, 6  
15 and 7 are shown to receive from nodes 1 to 3. For example, node 3 is enabled to transmit to nodes 4 and 6 at the same time as node 1 transmits to nodes 4, 6 and 7. Correspondingly, nodes 4 and 6 should receive data from more than one node during this slot t1. For example, node 6 may receive from  
20 nodes 1 and 3 at the same time.

The simultaneous active links for communication can be specified by appropriate messages transported on the control channel of the frame, as shown by Figure 4. The indication  
25 mechanism may be similar to the indication of the conventional active links that are intended for different timeslots.

A node that is about to receive from several other nodes  
30 simultaneously can separate the received data e.g. based on the above discussed smart antenna weights. Thus e.g. node 6 determines proper smart antenna weights for all transmitting nodes to be able to digitally separate the different incoming

signals. These weights can be based on the spatial-signature estimates. It is possible to set also other relevant parameters for this purpose, such as expected values for timing and frequency errors.

5

Nodes that have a high  $C_{SDMA}^N$  value generally use antenna arrays provided with a substantially high number of antenna elements. Transmissions by such nodes can be made highly directional. The substantially narrow beams are not likely to  
10 cause significant interference to other simultaneous active links.

On the other hand, nodes with substantially small  $C_{SDMA}^N$  value transmit with a low directivity. In particular, nodes with  
15  $C_{SDMA}^N = 1$  transmit and receive omnidirectionally unless they use a switched-beams approach or digital beam forming without SDMA. This may be referred to as a single-user smart-antenna operation. Such nodes may cause a substantially strong interference to other simultaneous active links. In order to  
20 optimise the operation of the system it may thus be advantageous to reserve simultaneous active links in a common neighbourhood in the same timeslot with those active links that have a substantially high  $C_{SDMA}^N$  in the transmitting side.

25 It is also possible that the system includes nodes for which the  $C_{SDMA}^N = 1$ . Of these nodes the ones with omnidirectional antennas are substantially different from the interference point of view from those nodes that use directional transmissions but do not support SDMA.

30

Thus it may be advantageous in certain situations to include a measure indicative of the transmission directivity of a node

to the list of parameters to be communicated to the neighbours in order to optimise further the scheduling of simultaneous communications. Even if the SDMA is not employed, and when the  $C_{SDMA}^N = 1$  for all the nodes, capacity can be enhanced through  
5 information regarding the transmit and receive directivity since this enables simultaneous active links for neighbouring nodes and enables relaxing the requirements of the basic NETS scheme.

10 Furthermore, for a single-user smart-antenna operation as well as for the SDMA the nodes can use zeroing (nulling) to further reduce unwanted interference (see the mathematical discussion regarding the interference below). Moreover, to optimise the zeroing performance, the lengths of the simultaneous  
15 transmissions in different active links in a common neighbourhood should preferably be as close to each other as possible. Otherwise a varying interference situation may occur during a single data packet - a situation which might not be as easily zeroed as the case with equal transmission lengths.

20 A measure that is indicative of the reception directivity of the receiving nodes can be of importance to the transmitting node also since the transmitting node may use this information in the scheduling operations to ensure that the transmissions  
25 thereof do not cause interference to reception of another active link.

The value of the capacity parameter may change e.g. based on changes in the capacity or in the quality of the radio  
30 connection. That is, a node may be upgraded or downgraded to handle more or less simultaneous communications. Furthermore, in situations where the load of the network is substantially high such that it is very unlikely that the node receives from

only one other node at a time and if there is only one choice for the training sequence, it may be advantageous if a node is able to temporarily set its capacity parameter value to unity in order to update the spatial-signature estimates for its  
5 neighbours. The current value of the capacity parameter may, for example, be included in the control-channel transmissions of each node or in some other control messages that are sent more seldomly.

10 According to a possibility a set of mutually orthogonal training signals is specified in the system. The transmissions to a node may then be scheduled such that transmissions from different nodes use different training signals. To achieve this information about the training signal that are used can  
15 be included in the control channel scheduling messages. Thus, after node 1, for example, has reserved timing for a node 1 to node 6 transmission, any node also wishing to transmit to node 6 at the same time may select a different training signal.

20 Based on different mutually orthogonal training signals for the different incoming transmissions the receiving node may estimate the spatial signatures during the SDMA operation. Thus it is possible to relax the requirement regarding the speed on which the radio channel may vary in the SDMA  
25 reception. Furthermore, to update channel estimates a node may not need to be set the value of the capacity parameter to unity.

The following will describe an exemplifying spatial signature  
30 determination procedure that relates to a wireless data communication system employing orthogonal frequency division multiplexing (OFDM) scheme. It shall be understood that the following is only an example, and other methods for the



estimation may also be used. In the OFDM the training sequence may consist of two identical consecutive OFDM symbols (training symbols) in which each of the subcarriers contain data that is known to the receiver .

5

The number of subcarriers depends on the particular communication standard. The following assumes that 52 subcarriers are employed. The system may apply e.g. 64 subcarrier frequencies, but of these only 52 subcarriers are used for data transmission. Of these 52 subcarriers, in turn, four are used as pilot carriers in all OFDM symbols. All the subcarriers used in the training symbols represent predefined data. Thus, the radio frequency radio channel ( $H$ ) between the terminal and an element  $n$  of the array of antennas for a subcarrier  $k$  can be estimated by equation:

15

$$H_n[k] = \left( \frac{1}{2} \sum_{p=1}^2 x_n[k, p] \right) \times d[k]^* , \quad (1)$$

in which  $x_n[k, p]$  is a signal received from the antenna element  $n$  in the frequency domain at a subcarrier frequency  $k=0, 1, \dots, 51$  representing the  $p^{\text{th}}$  training symbol in a training sequence transmitted by the terminal,  $d[k]$  is the training symbol for the subcarrier  $k$ , and the character \* as superscript indicates complex conjugation.

25

Because the effect of the radio channel is generally shown in time domain as a convolution with the transmitted signal, this corresponds, at each subcarrier frequency in the frequency domain, to complex multiplication of the transmitted symbol and the radio channel. It is now possible to determine a weight vector, whose complex conjugate is used in the

30

receiving station to weight signals received from the transmitting station by different antenna elements or signals to be transmitted from different antenna elements, for example depending on the frequency in the following way:

5

$$\bar{w}[k] = (H_0[k], H_1[k], H_2[k], \dots, H_{N-1}[k])^T \quad (2) \text{ [AA1]}$$

In (2) superscript  $T$  indicates transposition and  $N$  is the number of the antenna elements.

10

The weighting coefficient vector (2) can be referred to as a spatial signature. The weighting coefficient vector (2) can be used both for reception (uplink) and transmission (downlink).

15

The access point i.e. the router node may apply the space division multiple access (SDMA) for simultaneous transmission to e.g.  $M$  different router nodes. In order to enable this the spatial signatures of the different nodes may be generally modified, that is, the weighting coefficients  $\bar{w}_m[k]$  of the

20

weighting coefficient vector may be modified to the form  $\bar{w}'_m[k]$  so that when a signal intended for a node  $m = 1, 2, \dots, M$  is weighted by the weighting coefficients  $\bar{w}'_m[k]$ , the power

received by the node  $m$  is as high as possible and at the same time the power received by other nodes to be simultaneously

25

served from the transmission in question is as low as possible. Thus, for example, it can be required that:

$$\bar{w}'_a{}^H[k] \cdot \bar{w}_b[k] = \delta_{a,b} \quad \forall k, \quad (3)$$

30

in which  $\delta_{a,b}$  is a Kronecker delta (1 if  $a=b$  and zero otherwise) and  $\forall k$  indicates that the condition is valid for

each subcarrier frequency separately. This condition can be fulfilled for example by using the pseudo inverse:

$$A_{sdma}[k] = (A[k]^+)^H, \quad (4)$$

5

in which the superscript + indicates pseudo inverse and  $N \times M$  matrices  $A[k]$  and  $A_{sdma}[k]$  are defined:

$$A[k] = (\bar{w}_1[k], \bar{w}_2[k], \dots, \bar{w}_M[k]) \quad (5)$$

10 and

$$A_{sdma}[k] = (\bar{w}'_1[k], \bar{w}'_2[k], \dots, \bar{w}'_M[k]) \quad (6)$$

A corresponding modification can be accomplished in the receiving node. When a received signal is combined with the weighting coefficients  $\bar{w}'_a[k]$ , the signal transmitted by the transmitting node 'a' is amplified as much as possible, whereas the signals transmitted simultaneously by other nodes are attenuated as much as possible. In other words, the signal transmitted by the transmitting node is summed from the different antenna elements as coherently as possible when weighted with the weighting coefficients  $\bar{w}'_a[k]$ , whereas the signals of other nodes transmitting simultaneously are summed as incoherently as possible.

In most occasions it can be assumed that the weight vector and spatial signature mean essentially the same factor. For example, in Figure 1 node 1 is provided with an estimate of the direction in which node 2 is located. The weight vector that shall be used to form a transmission beam towards this direction corresponds to the spatial signature of node 2 as seen by node 1. That is, the spatial signature of node 2

depends on the position of node 2 relative to node 1. The weight vector for the forming of the beam from node 1 towards node 2 depends of the spatial signature of node 2 as seen by node 1.

5

The spatial signature is defined for a link between two nodes. If node 1 transmits to two nodes 2 and 3 at the same time it is possible for node 1 not to use the original weigh factors of nodes 2 and 3. Instead, node 1 may modify the weight factor  
10 vectors so that the other one of the two nodes is always zeroed. That is accomplished in order to prevent the transmission that was intended to node 2 to enter node 3 and vice versa (see the discussion above).

15 If the two nodes have a line of sight (LoS) between them, the direction and location of the receiving station can be considered to be the same. LoS is a typical condition when the router nodes are installed outdoors, such as in Figure 1. However, if the nodes do not have a visible contact with each  
20 other a substantial portion of the radio propagation may be subject to reflections. The reflected signals may arrive from various directions. Thus in certain circumstances it is more correct to understand the operation of a smart antenna system such that it directs the transmission and/or reception to a  
25 desired location, not just to a desired direction.

The TDD based systems are advantageous in this sense since the uplink and the downlink use the same frequency. In the TDD based systems it is not necessary to consider the directed  
30 transmissions in the terms of directions of the beams but, instead, the operation can be seen as a formation of a region of constructive interference around a node. For example, an

interference maximum can be located to be present around the location of a receiving node.

The spatial-signature estimates may need an update from time to time, depending on the application. The more slowly varying the radio environment is, the more seldom an update of the spatial-signature estimates is needed and vice versa.

Despite the possibility to update the value of the capacity parameter it may, however, be advantageous in some applications if the radio environment of a node does not vary too rapidly. Too rapid variations in the radio channel conditions may prevent use a spatial-signature estimate for a substantially long enough period of time, e.g. the use of a single spatial-signature measurement for several frames. This may be of especial importance if the system uses only one type of training sequence. This may be the case, for example, for HIPERLAN/2 WLAN as well as for the WRR.

On the other hand, the requirement for slowly-varying radio environment can be relaxed for SDMA reception if a set of mutually orthogonal training signals is specified in the system. More particularly, even if the radio environment varies substantially rapidly the SDMA may still be made feasible in the reception if the system defines a set of mutually orthogonal training signals.

In extreme conditions (e.g. a fast moving node) an estimate of the channel may be needed for every packet in systems that require use of antenna weights for the communication by means of directional radiation patterns. Consequently, the total number of possible simultaneous active links in the neighbourhood of an active link between a first and a second

node would be limited by the number of different training signals ( $C_{TR}$ ) that may be used. Thus in such circumstances the number of simultaneous active links to the second node may become limited by the  $C_{TR}$  value in addition to the limitation set by the capacity parameter. However, it shall be appreciated that this is not the case in all applications. For example, if fixedly mounted routers (see Figure 1) are used the radio channel is expected to remain the same over long enough periods of time.

It is also possible to estimate the interference content of the received signal. This may be done for example by forming a so called remainder signal

$$r_n[k, p] = x_n[k, p] - H_n[k] \times d[k] \quad (7)$$

for the training symbols ( $p = 1, 2$ ) that have been transmitted in an orthogonal system. To eliminate interference in the reception, the weighting coefficient vector can now be modified for example by multiplying it with the inverse matrix of the position correlation matrix of the remainder signal:

$$\bar{w}_{opt}[k] = (Q[k, p] + \gamma \times I)^{-1} \times \bar{w}[k], \quad (8)$$

in which  $Q[k, p]$  is the position correlation matrix of the remainder signal:

$$Q[k, p] = \bar{r}[k, p] \times \bar{r}[k, p]^H, \quad (9)$$

$$\bar{r}[k, p] = (r_0[k, p], r_1[k, p], r_2[k, p], \dots, r_{N-1}[k, p])^T, \quad (10)$$

the superscript  $H$  indicates complex conjugate transposition,  $I$  is  $N \times N$  unit matrix and  $\gamma$  is a small constant (for example,  $\gamma=0.01$ ) which makes the inverse matrix operation well-behaved in the equation (8). In equations (7) - (10) it is possible, for example, to restrict to use only one of the received training symbols, that is, for example to set  $p = 1$  in equations (7) and (8). Alternatively, the inverse matrix for the equation (8) can be calculated for each training symbol separately ( $p = 1$  and  $p = 2$ ) and to take the average of these inverse matrices. Good simulation results have also been obtained by averaging the position correlation matrix over the frequency, by calculating the inverse matrix as in equation (7), and finally by taking the average over the training symbols:

15

$$\bar{w}_{opt}[k] = \left\{ \frac{1}{P} \sum_{p=1}^P \left[ \left( \frac{1}{K} \sum_{k=0}^{K-1} Q[k, p] \right) + \gamma \times I \right]^{-1} \right\} \times \bar{w}[k], \quad (11)$$

in which thus  $P = 2$  and  $K = 52$  for the HIPERLAN/2 system.

It is also possible that at least one of the transmitting or receiving stations comprises a mobile user terminal. The mobile terminal comprises a mobile station enabled to communicate with another station. At least a part of the nodes of the data communication system may be arranged to provide an access point (AP) for the mobile terminal (MT). The access point may comprise appropriate transceiver and controller means such as those known from the base stations for the cellular telecommunication systems.

The mobile terminals and access points may be arranged such that the mobile terminals have omnidirectional antennae (one

for each MT) while the access points may use array antennas as discussed above, measure the spatial signatures of different mobile terminals and utilise the SDMA. Those nodes of the system which do not provide the access point feature may be similar to the router nodes described above. The router nodes may be provided with antenna arrays and utilise spatial signatures of the other nodes. The router nodes may be capable of communication with the other router nodes and also with those nodes that provide the access points. Each of the routers may also transmit to and/or receive from the mobile terminal in the manner similar to reception and/or transmission between the router nodes of the system.

It shall be appreciated that although the above example mainly considers use of a TDD/SDMA system, other duplexing and access techniques may also be used where appropriate. Thus this invention is also applicable to any other access techniques including code division multiple access (CDMA), frequency division multiple access (FDMA) as well as any hybrids thereof. Any multiplexing scheme where time or frequency slots or similar are allocated for the data to be transmitted may also be used.

It shall also be appreciated that whilst embodiments of the present invention have been described in relation to wireless routers, embodiments of the present invention are applicable to any other suitable type of nodes. Consequently the embodiments can be applied to other network elements where applicable.

The data is described as being in packet form. In alternative embodiments of the invention the data may be sent in any suitable format.



Advantage may also be obtained in gateway nodes that connect the wireless network to other networks. This is so because the gateway nodes typically form bottlenecks through which the traffic between a wireless mesh network (typically more local) and a wired network (typically more global) is directed. The gateway nodes are sometimes referred to as sinks.

It is also noted herein that while the above describes exemplifying embodiments of the invention, there are several variations and modifications which may be made to the disclosed solution without departing from the scope of the present invention as defined in the appended claims.

## Claims

1. A method in a data communication system, said system comprising a plurality of nodes provided with means for wireless data communication, the method comprising:
- 5 generating control information that associates with at least one node of the plurality of nodes, said control information including at least a capacity parameter associated with the capacity of said at least one node;
- 10 scheduling data communications that associate with said at least one node at a given moment of time, said scheduling being based on said control information;
- forming a directed wireless data communication link between a node and another node; and
- 15 communicating data between the nodes based on said scheduling.
2. A method as claimed in claim 1, wherein the directed wireless data communication link is formed by means of at least one directional radiation pattern.
- 20 3. A method as claimed in claim 2, wherein said at least one directional radiation pattern is formed by a smart antenna arrangement.
- 25 4. A method as claimed in any preceding claim, wherein the directed wireless data communication link is formed by means of digital beamforming.
- 30 5. A method as claimed in any preceding claim, comprising a step of estimating information associated with the location of said at least one node.

6. A method as claimed in any preceding claim, wherein each of the nodes of the system is allocated with a time slot on a control channel for the provision of control information to the others of the nodes.

5

7. A method as claimed in any preceding claim, wherein those nodes of the system that are served in a time slot are separated from each other based on information that associates with the spatial characteristics of neighbouring nodes.

10

8. A method as claimed in claim 7, wherein the information regarding the spatial characteristics of the neighbouring nodes is determined based on training signals.

15 9. A method as claimed in any preceding claim, wherein data transmissions between the nodes of the system are based on space division multiple access (SDMA) technique.

10 10. A method as claimed in claim 9, wherein the space division multiple access (SDMA) technique is used in combination with time division multiple access (TDMA) technique.

25 11. A method as claimed in any of claims 7 to 10, wherein information associated with the spatial characteristics is provided by means of spatial signatures.

30 12. A method as claimed in any preceding claim, wherein the nodes of the system reserve data communication resources by generating control information and transmitting said control information to other nodes.

13. A method as claimed in any preceding claim, wherein the control information includes information that identifies those nodes to which a node intends to transmit data.

5 14. A method as claimed in any preceding claim, wherein the control information includes information that identifies those nodes from which a node expects to receive data.

10 15. A method as claimed in claim 13 or 14, wherein only those nodes are identified with which a node is going to communicate during a data transmission entity.

15 16. A method as claimed in claim 15, wherein the data transmission entity comprises a time slot, and a node reserves communication resources by providing an indication of those nodes the said reserving node is going to be in communication with during said time slot.

20 17. A method as claimed in any preceding claim, wherein the control information includes start times and duration of communication links a node is intending to have with at least one of the nodes.

25 18. A method as claimed in any preceding claim, wherein the control information includes an indication of transmission and/or reception directivity of a node.

30 19. A method as claimed in any preceding claim, wherein the control information includes information that is associated with training signals to be used for the data communication between the nodes.

20. A method as claimed in any preceding claim, wherein the capacity parameter for a node defines the number of simultaneous active data communication links the node may have with other nodes.

5

21. A method as claimed in any preceding claim, comprising a step of updating the capacity parameter.

22. A method as claimed in any preceding claim, wherein the wireless data communication link is formed by means of a transmission beam that is directed to a certain direction.

10

23. A method as claimed in any of claims 1 to 21, wherein the wireless data communication link is formed by means of a transmission beam that is directed to a certain location.

15

24. A method as claimed in any preceding claim, wherein time division duplexing (TDD) is used for the communication between the nodes.

20

25. A method as claimed in any preceding claim, wherein the directed data communication link is formed by arranging multiple transmitted or received signals to constructively interfere at a desired location.

25

26. A method as claimed in any preceding claim, wherein non-directional communication links are used for communication of said control information between the nodes.

30

27. A method as claimed in any preceding claim, wherein the nodes transmit said control information on a control channel.

28. A method as claimed in any preceding claim, wherein a node is in simultaneous communication with a plurality of nodes during a common timeslot.

5 29. A method as claimed in any preceding claim, wherein a node is allowed to schedule a transmission to another node at time T if the number of already scheduled simultaneous transmission to said other node during that time is less than the value of the capacity parameter of said other node.

10

30. A method as claimed in any preceding claim, wherein at least one of nodes comprises a fixedly mounted router node for a data communication network.

15 31. A method as claimed in any preceding claim, wherein the data communication systems employs internet protocol for data communication.

32. A data communication system comprising:

20 a plurality of nodes, each of the nodes being provided with antenna means that are adapted to provide directed wireless data communication links with the others of the nodes; and

25 means for communicating control information between the nodes, the control information including capacity information associated with at least one of the nodes, wherein the arrangement is such that data communications between the nodes over said directed communication links are scheduled based on said control information.

30

33. A data communication system as claimed in claim 32, wherein the directed wireless data communication link is formed by means of at least one directional radio beam.

34. A data communication system as claimed in claim 33, wherein the antenna means comprise a smart antenna arrangement.

5

35. A data communication system as claimed in any of claims 32 to 34, wherein the antenna means comprise means for digital beamforming.

10

36. A data communication system as claimed in any of claims 32 to 35, wherein the control information includes also information associated with at least one of the following features or characteristics of the communication system: spatial characteristics of neighbouring nodes; indication of those nodes with which a node intends to communicate data; start times and duration of communication links a node is indenting to have with at least one other node; transmission and/or reception directivity of a node; training signals to be used for the data communication between at least two nodes.

20

37. A data communication system as claimed in any of claims 32 to 36, wherein data transmissions between the nodes of the system are based on space division multiple access (SDMA) technique.

25

38. A data communication system as claimed in any of claims 32 to 37, wherein the capacity parameter for a node defines the number of active data communication links the node may have at a time.

30

39. A data communication system as claimed in any of claims 32 to 38, wherein the means for communicating control information comprise non-directional antenna means.

40. A data communication system as claimed in any of claims  
32 to 39, wherein a node is enabled to be in simultaneous  
communication with a plurality of nodes during a common  
5 timeslot.

41. A data communication system as claimed in any of claims  
32 to 40, wherein at least one of nodes comprises a fixedly  
mounted router node for a data communication network.  
10



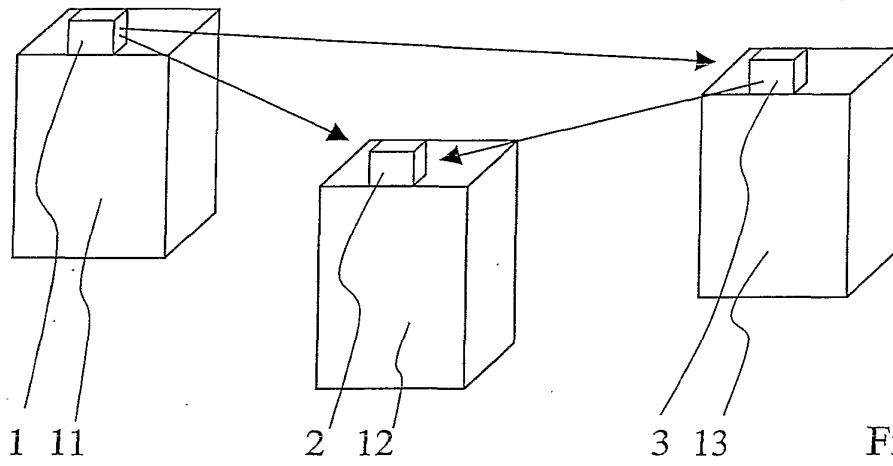


Fig. 1

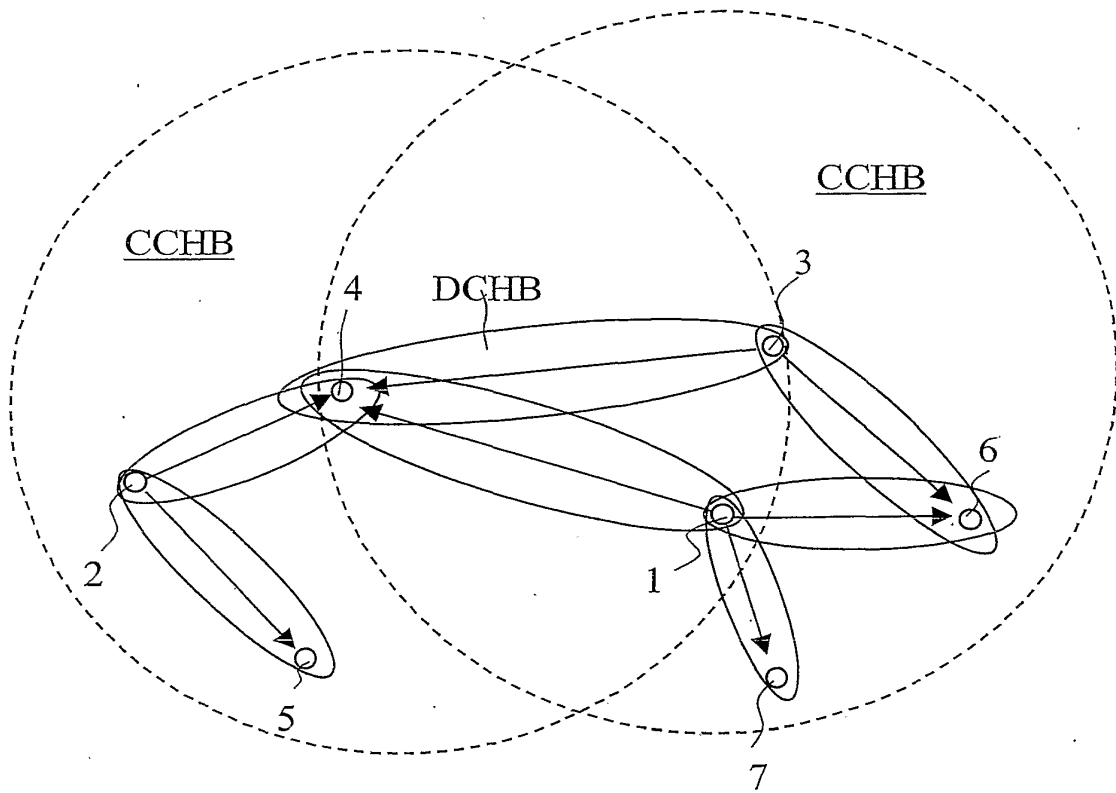


Fig. 2

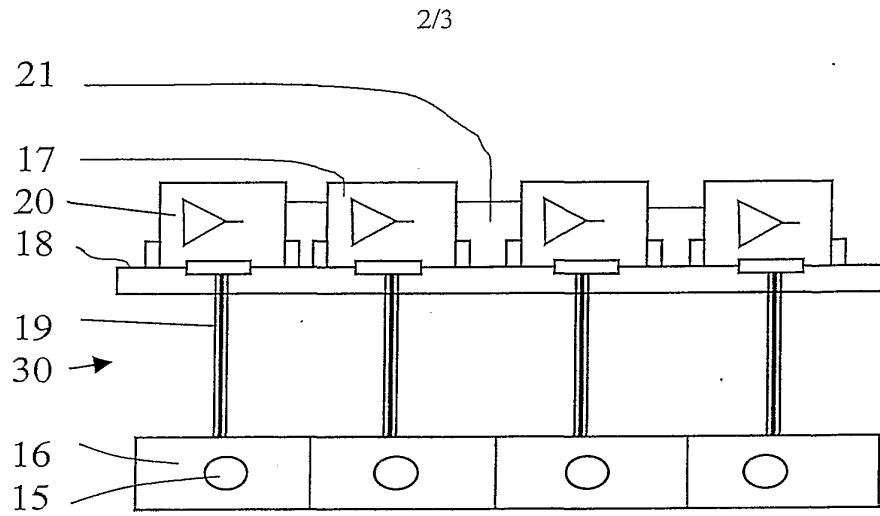


Fig. 3

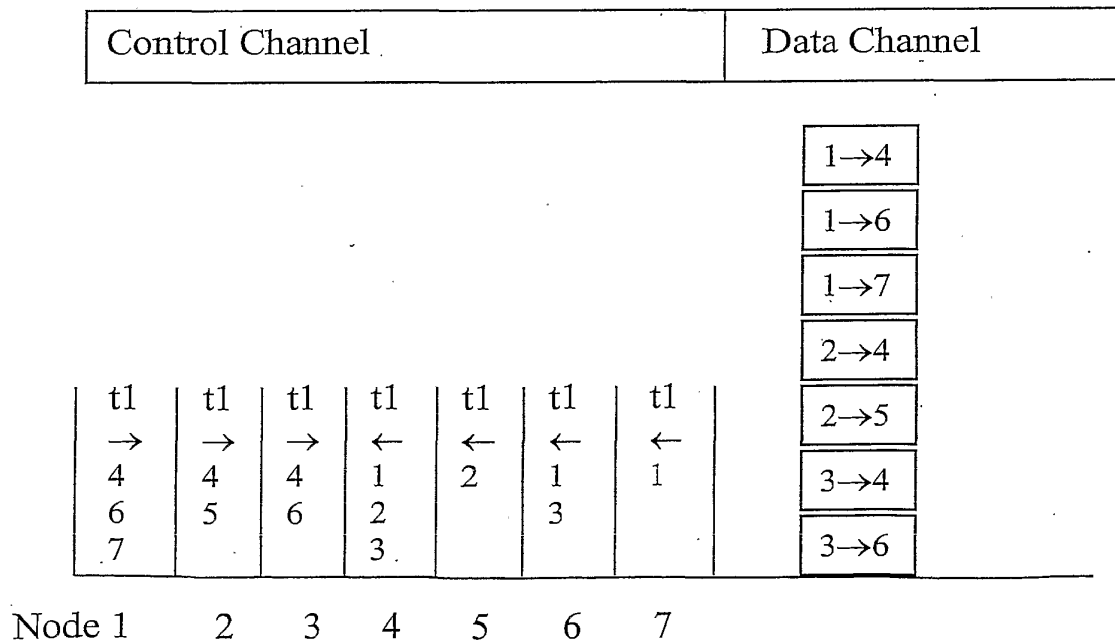


Fig. 4

3/3

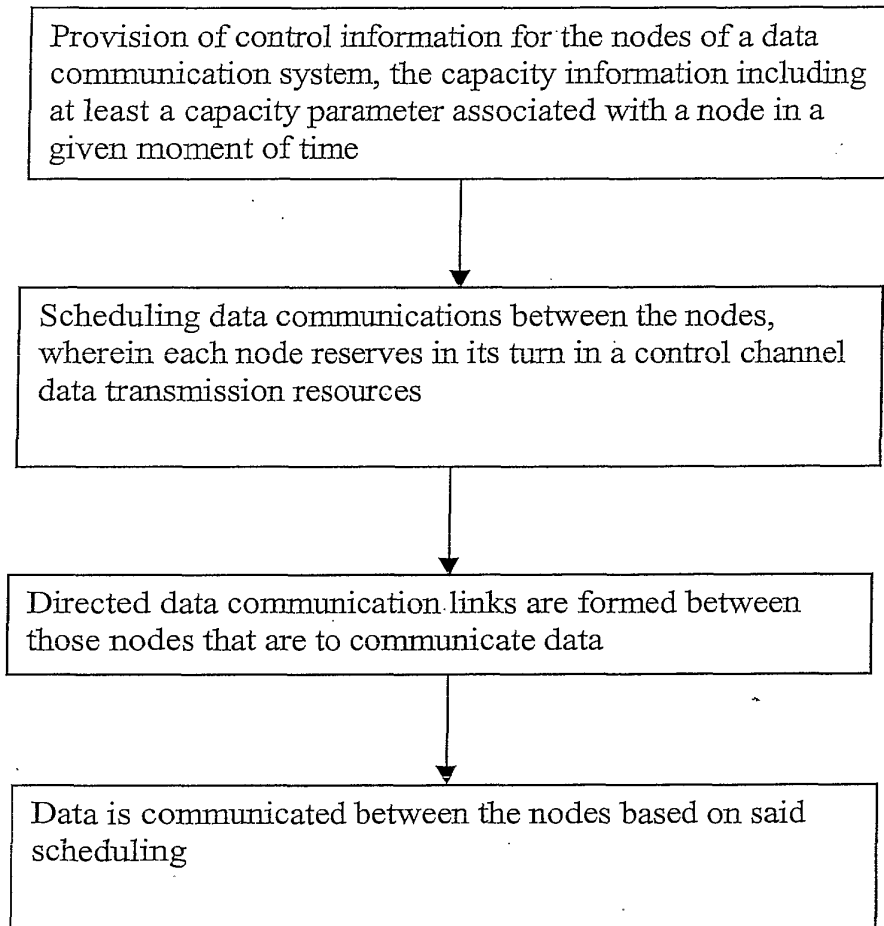


Fig. 5

(12) **EUROPEAN PATENT APPLICATION**

(43) Date of publication: **18.07.2001 Bulletin 2001/29** (51) Int Cl.7: **H04Q 7/38**

(21) Application number: **00311072.3**

(22) Date of filing: **12.12.2000**

(84) Designated Contracting States:  
**AT BE CH CY DE DK ES FI FR GB GR IE IT LI LU MC NL PT SE TR**  
 Designated Extension States:  
**AL LT LV MK RO SI**

(30) Priority: **12.01.2000 US 482476**

(71) Applicant: **LUCENT TECHNOLOGIES INC.**  
**Murray Hill, New Jersey 07974-0636 (US)**

(72) Inventors:  
 • **Aravamudan, Murali**  
**Murray Hill, New Jersey 07974 (US)**  
 • **Naqvi, Shamim A.**  
**Morristown, New Jersey 07960 (US)**

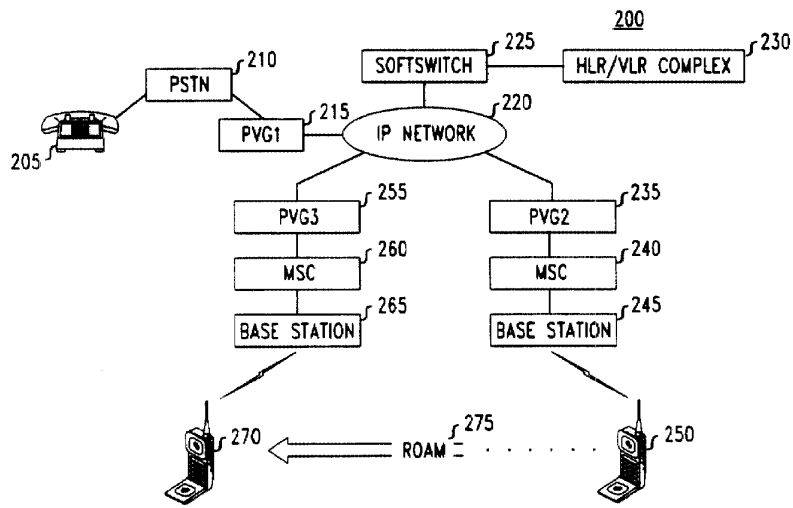
(74) Representative:  
**Watts, Christopher Malcolm Kelway, Dr. et al**  
**Lucent Technologies (UK) Ltd,**  
**5 Mornington Road**  
**Woodford Green Essex, IG8 0TU (GB)**

(54) **Dynamic routing of wireless communications**

(57) A method and apparatus for dynamic routing of wireless communications. More particularly, wireless communications are dynamically routed by marking, by a softswitch, every endpoint participating in a call and as the entry for a marked endpoint is updated a message is generated and sent to the softswitch. Upon receiving such a message, the softswitch re-computes the necessary new resources for maintaining the call and (i) instructs such new resources to negotiate media

transfer, (ii) after receiving an acknowledgement from the new resources, transmits appropriate call initiation messages to such resources; and (iii) transmits call release messages to the prior, i.e., old, resources supporting the call. Advantageously, selection of the requisite resources to participate in a particular is driven by the knowledge of the communications network topology. As such, resources are selected which are topologically closer to the endpoint thereby increasing the efficiency of the network resources on a network-wide basis.

**FIG. 2**



**EP 1 117 270 A2**

**Description****Field of the Invention**

**[0001]** The present invention relates to wireless communications systems, and more particularly, to dynamically routing calls in wireless communications networks.

**Background of the Invention**

**[0002]** A well-known feature of conventional telecommunications systems which provide telephone service, e.g., public switched telephone network (PSTN), central offices (CO), private branch exchange (PBX), and Internet telephony servers, is that such systems are discrete islands of functionality, and each such island has its own particular syntax and semantics. The use of the different syntaxes, semantics, and protocols, makes it difficult to easily interconnect the various islands, and it is virtually impossible to provide features that work together seamlessly across the various islands.

**[0003]** Further, the increasing growth of wireless communications in terms of both voice and data communications only adds to the above-described network complexity. For example, FIG. 1 shows a conventional wireless communications system architecture 100 as is popular with current day wireless communications service providers. More particularly, wireless communications system architecture 100 includes wireless terminals 110-1 through 110-N, wireless base stations 120-1 through 120-N, mobile switching center (MSC) 130, MSC 140, and public network 150 (e.g., the well-known PSTN).

**[0004]** As will be readily understood, a user employing a wireless terminal, e.g., wireless terminal 110-1, initiates a call, to a wireless or wireline endpoint, and is connected with a base station, e.g., base station 120-2, which, in turn, routes the call through MSC 130 and public network 150 to the intended endpoint. As such, the PSTN, e.g., public network 150, as it currently exists allows a wireless endpoint, e.g., wireless terminal 110-1, participating in a call with a wireline endpoint to sever its connection with a particular base station, e.g., base station 120-2, and be connected to another base station, e.g., base station 120-1, as the wireless endpoint moves, i.e., roams, within the network. As the base stations are each connected to a MSC and the MSC is connected to a circuit switch in the PSTN, this allows the roaming wireless endpoint to effectively roam within the MSC's immediate network.

**[0005]** However, the connection between the PSTN and the particular MSC remains fixed for the duration of the call such that call cannot be dynamically (as used herein the terms "dynamic" or "dynamically" mean real-time) routed to a different PSTN circuit switch as the wireless endpoint is roaming in the network. Thus, this leads to problems such as call being "dropped". That is,

as the wireless endpoint roams in the network it is connected to various base stations at various times. A certain number of such base stations maintain a connection with a particular MSC. During roaming, a wireless endpoint may find itself connected with a base station which is not associated with the original MSC. Thus, the wireless endpoint is no longer associated with the original MSC and, hence, loses its connection to the PSTN.

**[0006]** Complicating matters further is that evolution of next generation networks is centered on the convergence of voice and data networks. That is, it appears highly likely that next generation communications network will be an evolution of today's PSTN and Internet Protocol (IP) networks. Today's communications service providers are being driven by a number of factors in the development of such next generation networks such as: (1) the well-known Internet is becoming a major network choice for distribution of voice and data; (2) IP usage is increasing at a dramatic rate thereby causing bandwidth problems on existing PSTN networks carrying significant data traffic; (3) convergence of PSTN and packet networks (e.g., IP networks) is required to allow for end-to-end delivery of communications services; (4) the creation of new services connected with the increasing use of packet networks; and (5) increasing deregulation in the marketplace is creating new and competitive telecommunications environments for established, new, and specialized service providers in both voice and data traffic.

**[0007]** One major underlying feature in delivering such next generation communications networks is network interoperability. That is, the service providers ability to offer valued added communications services across circuit and packet networks is tied directly to the ability of providing interoperability across a number of heterogeneous networks that support a wide range of signaling protocols (e.g., SS7, IP, Media Gateway Control Protocol (MGCP), H.323, Session Initiation Protocol (SIP) and the like). An emerging switching platform useful in resolving such network interoperability issues is so-called "software switching". Software switches (also known in the art as "softswitches") are a multi-protocol software solution for signaling and transport thereby providing interoperability across heterogeneous networks, e.g., circuit and packet networks. One present commercially available softswitch is the Lucent Technologies Softswitch, available from Lucent Technologies Inc., 600 Mountain Ave., Murray Hill, NJ 07974. In conjunction with the LT Softswitch, PSTN and Internet Telephony Service Providers can provide seamless interoperability between PSTN and IP network domains.

**[0008]** In these future communications networks, circuit switches that carry telecommunications traffic will be replaced by so-called Packet Voice Gateways (PVG) utilizing packet technology for enabling telecommunications. Essentially, a PVG is a device for converting TDM traffic to IP packets and vice versa. Packet Voice Gateways fall into two main categories: (1) Trunking Gate-

ways (TG); and (2) Access Gateways (AG). As will be appreciated, the main differences between TG's and AG's is the traffic capacity of each and their respective signaling support. Typically, a TG does not terminate PSTN signaling whereas an AG typically provides integrated services digital network primary rate (ISDN PRI) and other Channel Associated Signaling (CAS) support. In softswitch-controlled networks, both the TG and the AG are controlled via well-known control protocols. In these networks, call setup will be controlled by the softswitch which will instruct PVG's in the network of incoming calls, and the routing of these calls to other PVGs and endpoints. Thus, the softswitch primarily handles the control, i.e., signaling, of data and not voice, i.e., media, traffic which is handled by the PVG. The softswitch instructs the PVG's on how to negotiate with each other and in the efficient handling of the media traffic.

**[0009]** An aspect of the invention herein is directed to effectively making routing decisions in such networks and, in particular, to facilitating the dynamic routing of wireless communications in such networks.

#### Summary of the Invention

**[0010]** An aspect of the present invention is directed to a method and apparatus for dynamic, i.e., in real-time, routing of wireless communications. More particularly, in accordance with an aspect of the invention, wireless communications are dynamically routed by marking, by a softswitch, every endpoint participating in a call and as the entry for a marked endpoint is updated a trigger, e.g., a message, is generated and sent to the softswitch. The generation of such messages will occur under a variety of circumstances, e.g., as a wireless terminal roams to different positions in a network. Upon receiving such a message, the softswitch re-computes an updated set of the necessary network resources for maintaining the call and (i) instructs such updated network resources to negotiate media transfer, that is, a re-negotiation occurs with respect to the handling of the media traffic, i.e., voice traffic, in the that the softswitch determines that a new set of PVG's should handle the media, and instructs such PVG's to re-negotiate the media traffic; (ii) after receiving an acknowledgement from the updated set of resources, the softswitch transmits appropriate call initiation messages to such resources; and (iii) transmits call release messages to the prior, i.e., old, resources supporting the call.

**[0011]** In accordance with the preferred embodiment of the invention, a call setup request originates from a network, e.g., the well-known SS7 signaling network of the PSTN, and arrives in a packet-switched network that is controlled by a softswitch. In accordance with this preferred embodiment, the softswitch selects a pair of packet voice gateways (PVG1 and PVG2, respectively) to enable media transfer through the packet-switched network and instructs the originating network to direct the media, e.g., the call, to PVG1. Additionally, the soft-

switch instructs PVG1 and PVG2 to negotiate media transfer between one another, e.g., in a IP network this negotiation will involve well-known RTP/UDP/IP address and port negotiation. Further, PVG2 is instructed to terminate the call on some other network element, e.g., a PSTN circuit switch, a MSC or an endpoint. After the aforementioned PVG negotiation is complete, media transfer is initiated from the originating switch to PVG1, and from PVG1 to PVG2. In accordance with this preferred embodiment, PVG2 is connected to a MSC based on the endpoint's location as defined by a database entry in a well-known Home Location Register (HLR) and/or Visitor Location Register (VLR) (hereafter referred to in combination as a "HLR/VLR complex"). As will be appreciated, HLR's and VLR's play an integral role with MSC's to route a wireless call throughout a wireless network as the endpoints roam in the network.

**[0012]** As the endpoints roam, in accordance with the preferred embodiment, the corresponding HLR/VLR complex entry is updated. As such updates occur, messages are sent by the HLR/VLR complex to the softswitch which recomputes the necessary new, i.e., updated, resources (e.g., one or more PVG's) for maintaining the call and (i) instructs such new resources to negotiate media transfer, (ii) after receiving an acknowledgement from the new resources, transmits appropriate call initiation messages to such resources; and (iii) transmits call release messages to the prior, i.e., old, resources supporting the call.

**[0013]** Advantageously, in accordance with an aspect of the invention, selection of the requisite resources to participate in a particular call is driven by the knowledge of the communications network topology. As such, resources are selected which are topologically closer to the endpoint thereby increasing the efficiency of the network resources on a network-wide basis.

#### Brief Description of the Drawings

**[0014]**

FIG. 1 shows a conventional wireless communications system architecture;

FIG. 2 shows an exemplary architecture for routing wireless communications in accordance with an embodiment of the invention; and

FIG. 3 is a flowchart of illustrative operations for routing wireless communications in accordance with the principles of the invention.

**[0015]** Throughout this disclosure, unless otherwise noted, like elements, blocks, components or sections in the figures are denoted by the same reference designations.

#### Detailed Description

**[0016]** An aspect of the present invention is directed

to a method and apparatus for dynamic routing of wireless communications. More particularly, in accordance with an aspect of the invention, wireless communications are dynamically routed by marking, by a softswitch, every endpoint participating in a call and as the entry for a marked endpoint is updated a message is generated and sent to the softswitch. Upon receiving such a message, the softswitch re-computes the necessary new resources for maintaining the call and generates the requisite instructions to such new resources to negotiate and implement media transfer. Advantageously, in accordance with an aspect of the invention, selection of the requisite resources to participate in a particular call is driven by the knowledge of the communications network topology. As such, resources are selected which are topologically closer to the endpoint thereby increasing the efficiency of the network resources on a network-wide basis.

**[0017]** More particularly, turning our attention to FIG. 2 and FIG. 3, FIG. 2 shows an exemplary architecture 200 for routing wireless communications in accordance with a preferred embodiment of the invention, and FIG. 3 is a flowchart of illustrative operations 300 for routing wireless communications in accordance with the principles of the invention. In particular, in accordance with exemplary architecture 200 and the preferred embodiment, a call is initiated by a calling party from POTS telephone 205 to a called party at wireless terminal 250. As such, a call setup request is initiated (FIG. 3, block 310) and extended through PSTN 210 to a packet-switched network, e.g., IP network 220. IP network 220 is controlled by softswitch 225 which, in accordance with the preferred embodiment, is the aforementioned Lucent Technologies Softswitch, available from Lucent Technologies Inc. (hereinafter alternatively referred to as the "LT Softswitch") A more detailed description of the LT softswitch architecture and its operation is contained in EP-A-0963096 and in EP application no. 00 306 724.6

**[0018]** Softswitch 225 selects the necessary network resources (see, FIG. 3, block 320). For example, *inter alia.*, a pair of packet voice gateways, in particular, PVG1 215 and PVG2 235 are selected to enable media transfer through IP network 220. Further, softswitch 225 instructs PSTN 210 to direct the media, e.g., the voice traffic, to PVG1 215, and instructs the network resources, e.g., PVG1 215 and PVG2 235, respectively, (see, FIG. 3, block 330) to negotiate media transfer between themselves. For example, in IP networks this negotiation will typically involve well-known RTP/UDP/IP address and port negotiation. Softswitch 225 further instructs PVG2 235 to extend the call to some further network element. In accordance with the instant embodiment, PVG2 235 extends the call to MSC 240 which thereafter, in a conventional manner, completes the wireless call extension through base station 245 to wireless terminal 250. As such, the call is extended from the originating network to the terminating network (see, FIG.

3, block 340).

**[0019]** In accordance with the embodiment of FIG. 2, PVG2 235 is connected to MSC 240 as a function of the location of wireless terminal 250, i.e., an endpoint, as indicated by its conventional entry in HLR/VLR complex 230. That is, as will be appreciated, HLR/VLR complex 230 contains at least one database storing subscription information with respect to a set of wireless terminals for facilitating communications in a wireless communications network. For example, HLR/VLR complex 230 may contain information about terminals that are currently in a specific wireless service area, or a particular terminal's current location and status. Therefore, the information in HLR/VLR complex 230 changes frequently as subscribers, i.e. endpoints, change location and plays an integral part as roaming occurs in the wireless network.

**[0020]** As mentioned previously, an aspect of the invention herein is directed to effectively making routing decisions in networks and, in particular, to facilitating the dynamic routing of wireless communications in such networks. That is, an aspect of the present invention is directed to a method and apparatus for dynamic, i.e., in real-time, routing of wireless communications. More particularly, in accordance with an aspect of the invention, wireless communications are dynamically routed by marking, by a softswitch, every endpoint participating in a call and as the entry for a marked endpoint is updated a message is generated and sent to the softswitch. Upon receiving such a message, the softswitch re-computes the necessary new resources for maintaining the call and generates the requisite instructions to such new resources to negotiate and implement media transfer.

**[0021]** Thus, in accordance with the preferred embodiment, all endpoints participating in a call are marked at the softswitch (see, FIG. 3, block 350). For example, in the illustrative embodiment of FIG. 2, a mark is made at softswitch 225 with respect to POTS telephone 205 and wireless terminal 250. Illustratively, a mark is an entry in a database identifying and describing a particular endpoint. As will be appreciated, the database may be internal to the softswitch or located externally from the softswitch. Now, suppose that the called party using wireless terminal 250 begins to roam. As explained above, such roaming will effect a change in the entry stored in HLR/VLR complex 230. Thus, in accordance with an aspect of the invention, as the entry for a marked endpoint is updated in HLR/VLR complex 230 a message is generated by HLR/VLR complex 230 and transmitted to softswitch 225 (see, FIG. 3, block 360). Upon receiving such a message, softswitch 225 recomputes (see, FIG. 3, block 360) the network resources necessary to maintain or re-establish the particular call. After such recomputation of the requisite network resources is completed, softswitch 225 instructs the updated network resources to negotiate media transfer to maintain/re-establish the call (see, FIG. 3, block 370). Illustrative-

ly, as such instructions to the updated network resources are received, acknowledgement is received by the softswitch from the updated network resources and the softswitch transmits appropriate call initiation messages (see, FIG. 3, block 370) to the updated resource set. In addition, softswitch 225 will generate call release messages to the old, i.e., no longer required to maintain the call, network resources (see, FIG. 3, block 380).

**[0022]** As such, resources are selected which are topologically closer to the endpoint thereby increasing the efficiency of the network resources on a network-wide basis. For example, in the illustrative embodiment of FIG. 2, as wireless terminal 250 roams in the network (see, e.g., roaming path 275), softswitch 225, in accordance with an aspect of the invention, is enabled to select those resources which are topologically closer to the endpoint for continuing to maintain the call. Thus, the call originally carried via PVG2 235, MSC 240 and base station 245, is dynamically routed to PVG3 255, MSC 260 and base station 265. Thus, the call is rerouted and extended to wireless terminal 270 without the connection between the PSTN and the particular MSC remaining fixed for the duration of the call such that call can be dynamically routed to a different PSTN circuit switch as the wireless endpoint is roaming in the network. Advantageously, in accordance with an aspect of the invention, selection of the requisite resources to participate in a particular call is driven by the knowledge of the communications network topology thereby increasing overall network efficiency and utilization.

**[0023]** Of course, while the illustrative embodiment discussed herein includes a single softswitch, it will be understood that the principles of the invention apply to further embodiments involving multiple softswitches thereby providing scalability. For example, in larger size networks it will be necessary to deploy multiple softswitches in order to efficiently process the larger call volume. Such scalability is achieved by employing multiple softswitches which communicate with each other via softswitch-to-softswitch control protocols. Thus, the larger amount of call traffic in the network is distributed across several softswitches. In accordance with such further embodiments of the invention, multiple softswitches may share the same HLR/VLR complex. Thus, messages triggered from the HLR/VLR complex may be routed to a particular softswitch and thereafter routed to other softswitches. Thus, for example, in accordance with such further embodiments of the invention, a wireless endpoint may roam in several networks (operated by different service providers) controlled by multiple softswitches thereby allowing the wireless endpoint to maintain a call across different service provider networks.

**[0024]** As detailed above, the present invention can be embodied in the form of methods and apparatuses for practicing those methods. The invention can also be embodied in the form of program code embodied in tangible media, such as floppy diskettes, CD-ROMs, hard

drives, or any other machine-readable storage medium, wherein, when the program code is loaded into and executed by a machine, such as a computer, the machine becomes an apparatus for practicing the invention. The invention can also be embodied in the form of program code, for example, in a storage medium, loaded into and/or executed by a machine, or transmitted over some transmission medium, such as over electrical wiring or cabling, through fiber optics, or via electromagnetic radiation, wherein, when the program code is loaded into and executed by a machine, such as a computer, the machine becomes an apparatus for practicing the invention. When implemented on a general-purpose processor, the program code segments combine with the processor to provide a unique device that operates analogously to specific logic circuits.

**[0025]** Furthermore, all examples and conditional language recited herein are principally intended expressly to be only for pedagogical purposes to aid the reader in understanding the principles of the invention and the concepts contributed by the Applicants to furthering the art, and are to be construed as being without limitation to such specifically recited examples and conditions. Moreover, all statements herein reciting principles, aspects, and embodiments of the invention, as well as specific examples thereof, are intended to encompass both structural and functional equivalents thereof. Additionally, it is intended that such equivalents include both currently known equivalents as well as equivalents developed in the future, i.e., any elements developed that perform the same function, regardless of structure.

**[0026]** Thus, for example, it will be appreciated by those skilled in the art that the block diagrams herein represent conceptual views of illustrative circuitry embodying the principles of the invention. Similarly, it will be appreciated that any flowcharts, flow diagrams, state transition diagrams, pseudocode, program code, and the like represent various processes which may be substantially represented in computer readable medium and so executed by a computer, machine, or processor, whether or not such computer, machine, or processor, is explicitly shown.

#### 45 Claims

1. A method for routing a call between a first endpoint and a second endpoint in a communications network, the call being extended between the first endpoint and the second endpoint utilizing a first set of network resources, the method comprising:

marking respective entries in a database related to the first endpoint and the second endpoint, respectively;  
 updating the entries in the database as a function of a location of the second endpoint; and  
 determining, in response to the updating the



- entries, a second set of network resources for maintaining the call extended between the first endpoint and the second endpoint.
2. The method of claim 1 further comprising:
    - generating a set of call initiation messages; transmitting the set of call initiation messages to the second set of network resources; and routing the call using the second set of network resources.
  3. The method of claim 2 further comprising:
    - generating a set of call release messages; and transmitting the set of call release messages to the first set of network resources.
  4. The method of claim 1 wherein the database is accessible by a softswitch.
  5. The method of claim 4 wherein the determining the second set of network resources is performed by the softswitch.
  6. The method of claim 5 wherein the updating the entries is performed in response to a message from a HLR/VLR complex, the message identifying the location of the second endpoint.
  7. The method of claim 5 wherein the first endpoint includes a POTS telephone and the second endpoint includes a wireless terminal.
  8. The method of claim 3 wherein the second set of network resources includes at least a pair of packet voice gateways (PVG).
  9. The method of claim 8 wherein the pair of PVG's are used to route the call between a PSTN network and a IP network.
  10. A method for maintaining a call extended between a plurality of endpoints in a communications network, the method comprising:
    - marking respective entries in a communications database related to particular ones of the endpoints utilized to extend the call; updating the entries in the communications database as a function of a location of at least one endpoint; and determining, in response to the updating the entries, a set of network resources for maintaining the call extended between the plurality of endpoints.
  11. The method of claim 10 further comprising:
    - routing the call through the set of network resources.
  12. The method of claim 11 further comprising:
    - receiving a message from a HLR/VLR database that identifies that the location of the at least one endpoint has changed.
  13. The method of claim 12 wherein the communications network includes at least one PSTN and at least one IP network.
  14. The method of claim 13 wherein the second endpoint is a wireless terminal.
  15. The method of claim 13 wherein the location of the at least one endpoint is a function of a roaming of the wireless terminal within a geographic region.
  16. A communications system for extending a call through a plurality of endpoints comprising:
    - a communications complex for tracking a location of particular ones of the endpoints; and at least one softswitch for receiving at least one message from the communications complex, the at least one message being generated as a function of a change in the location of at least one endpoint, and for determining a set of network resources for the extending the call.
  17. The communications system of claim 16 wherein the communications complex includes a HLR database.
  18. The communications system of claim 17 wherein the communications complex includes a VLR database.
  19. The communications system of claim 18 wherein the softswitch receives the message from the HLR database and determines the set of network resources as a function of the message.
  20. The communications system of claim 17 wherein the communications system includes at least one PSTN and at least one IP network.
  21. The communications system of claim 20 wherein the second endpoint is a wireless terminal.
  22. The communications system of claim 21 wherein the wireless terminal is roaming in a geographic region serviced by the communications system.
  23. The communications system of claim 22 wherein the change in the location of the at least one endpoint is a function of the roaming of the wireless terminal.

minal within the geographic region.

**24.** The communications system of claim 20 wherein the softswitch controls the IP network.

5

**25.** The communications system of claim 19 wherein the set of network resources includes at least one packet voice gateway.

**26.** A machine-readable medium having stored thereon a plurality of instructions, the plurality of instructions including instructions that, when executed by a machine, cause the machine to perform a method as claimed in any of claims 1 to 15.

10

15

20

25

30

35

40

45

50

55

7

FIG. 1

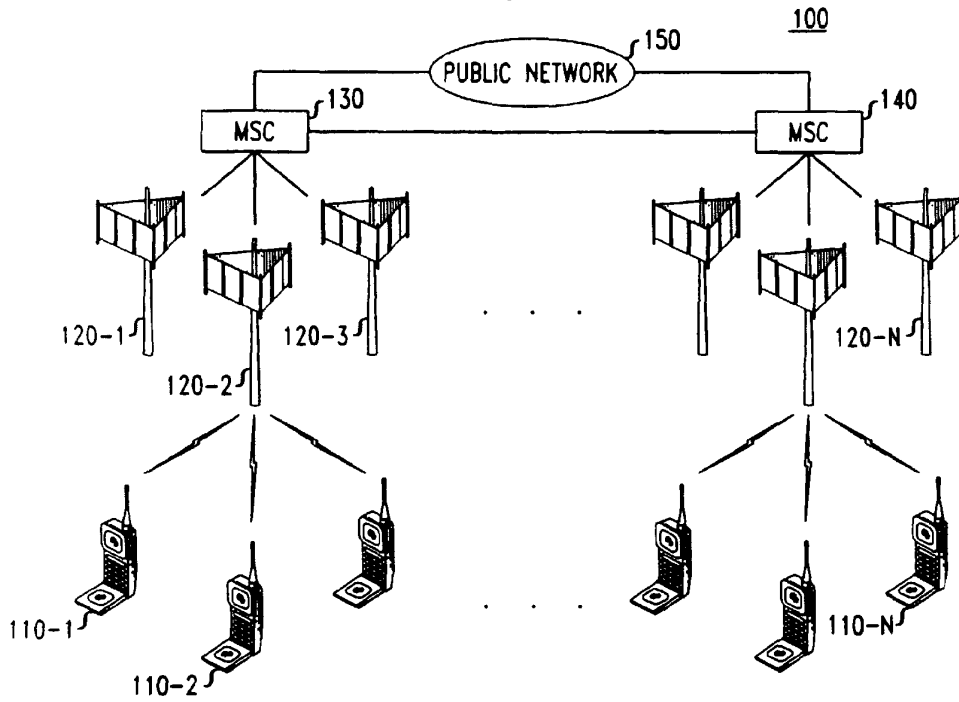


FIG. 2

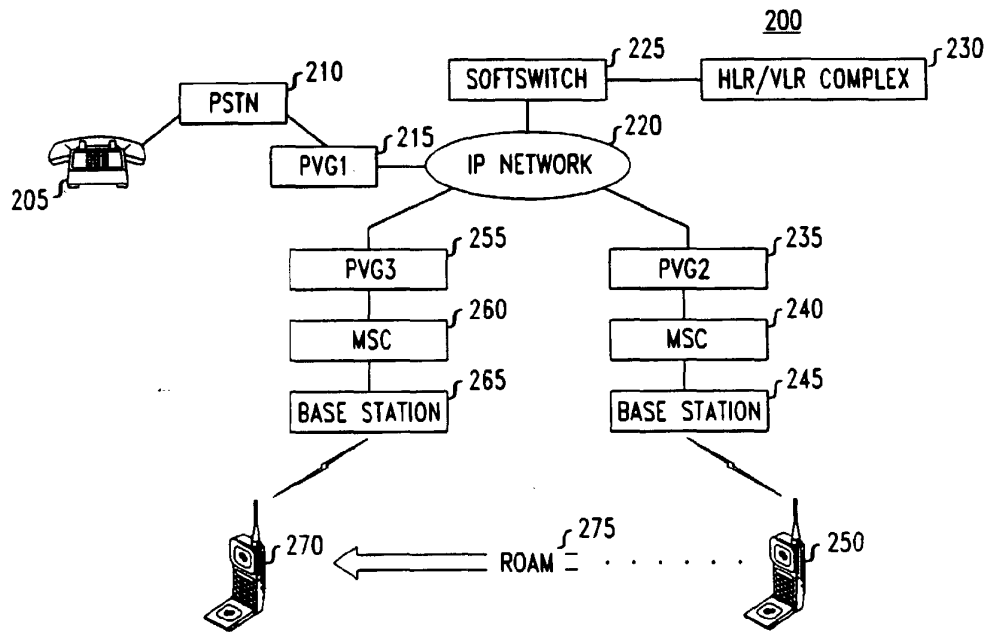
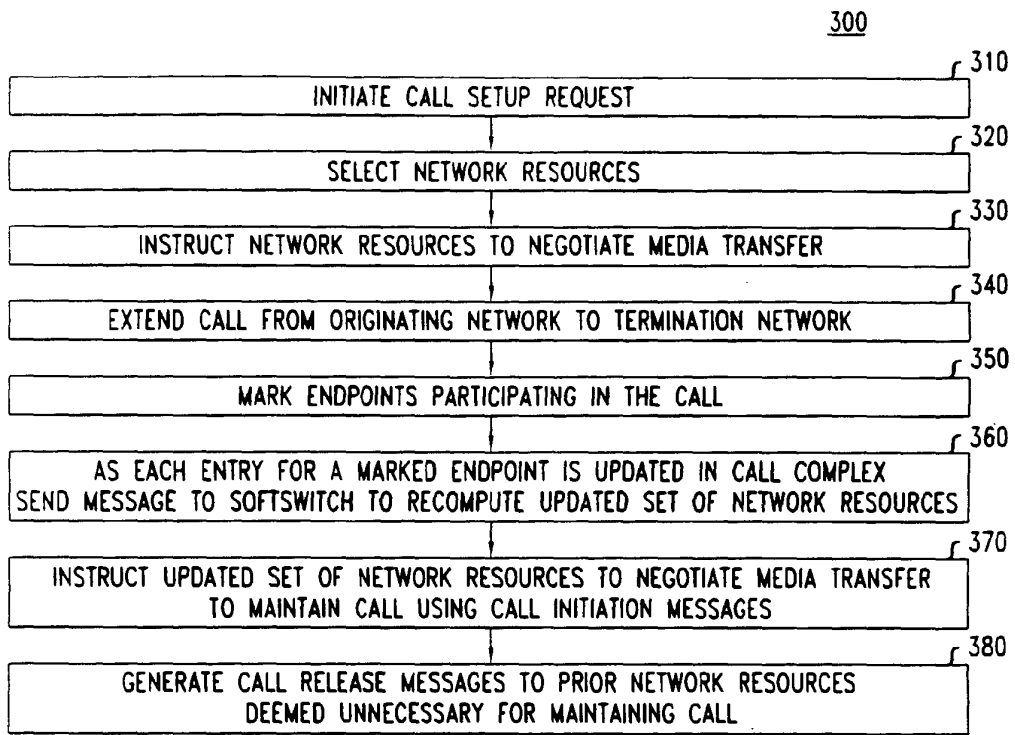


FIG. 3



## Electronic Acknowledgement Receipt

<b>EFS ID:</b>	33348676
<b>Application Number:</b>	15495539
<b>International Application Number:</b>	
<b>Confirmation Number:</b>	1050
<b>Title of Invention:</b>	DIRECTED WIRELESS COMMUNICATION
<b>First Named Inventor/Applicant Name:</b>	Marcus Da Silva
<b>Customer Number:</b>	22145
<b>Filer:</b>	Glen L. Nuttall/Mariel Boyan
<b>Filer Authorized By:</b>	Glen L. Nuttall
<b>Attorney Docket Number:</b>	1640-001.203
<b>Receipt Date:</b>	01-AUG-2018
<b>Filing Date:</b>	24-APR-2017
<b>Time Stamp:</b>	17:47:23
<b>Application Type:</b>	Utility under 35 USC 111(a)

### Payment information:

Submitted with Payment	no
------------------------	----

### File Listing:

Document Number	Document Description	File Name	File Size(Bytes)/ Message Digest	Multi Part /.zip	Pages (if appl.)
1		1640-001-203-- IDSAsFiled08012018.pdf	426542  eb84458129ada2fb7c88769bec5b8cb2b71d946e	yes	6

Multipart Description/PDF files in .zip description					
Document Description			Start	End	
Information Disclosure Statement (IDS) Form (SB08)			4	6	
Transmittal Letter			1	3	
<b>Warnings:</b>					
The page size in the PDF is too large. The pages should be 8.5 x 11 or A4. If this PDF is submitted, the pages will be resized upon entry into the Image File Wrapper and may affect subsequent processing					
<b>Information:</b>					
2	Foreign Reference	GB2349045A.pdf	1662577	no	43
			1e9ac5002304aad9c29727661ac9cc5abcca bbf2		
<b>Warnings:</b>					
<b>Information:</b>					
3	Foreign Reference	WO0038455A1.pdf	1134190	no	33
			e98c3c4abe5c466f4fe2ee02d04ba91fab665 268		
<b>Warnings:</b>					
<b>Information:</b>					
4	Foreign Reference	WO02063836A2.pdf	1589220	no	38
			c73dd90f7ebc2d4cecc0b508fb0ae147dc8e b027a		
<b>Warnings:</b>					
<b>Information:</b>					
5	Foreign Reference	EP1117270A2.pdf	553790	no	9
			e9403f5aa17c00ce63adbe5f10a3ee9bafef1 37ea		
<b>Warnings:</b>					
<b>Information:</b>					
6	Non Patent Literature	IPR2018-00762-1.pdf	14657236	no	50
			088aaeab7c0692ffb86f01fc2661809f8c924 97c		
<b>Warnings:</b>					
<b>Information:</b>					

7	Non Patent Literature	IPR2018-00762-2.pdf	13287227	no	42
			696eaa0d538466d50a1985515526e39707e1d981		
<b>Warnings:</b>					
<b>Information:</b>					
8	Non Patent Literature	IPR2018-00763.pdf	1950163	no	72
			0481a11791ff3b65d96518accabb03034e94cd6		
<b>Warnings:</b>					
<b>Information:</b>					
9	Non Patent Literature	IPR2018-00764.pdf	2541956	no	83
			a6fce9b27d4fc2c76cc036fffa1ecaabdb0e32e7bf		
<b>Warnings:</b>					
<b>Information:</b>					
10	Non Patent Literature	IPR2018-00725.pdf	934432	no	68
			36ade2e3742908f33041a2abada184a1e4271b8		
<b>Warnings:</b>					
The page size in the PDF is too large. The pages should be 8.5 x 11 or A4. If this PDF is submitted, the pages will be resized upon entry into the Image File Wrapper and may affect subsequent processing					
<b>Information:</b>					
11	Non Patent Literature	IPR2018-00726.pdf	851557	no	53
			0a0d07d875194fc9bc2db58f7f9644bbd304df40		
<b>Warnings:</b>					
The page size in the PDF is too large. The pages should be 8.5 x 11 or A4. If this PDF is submitted, the pages will be resized upon entry into the Image File Wrapper and may affect subsequent processing					
<b>Information:</b>					
12	Non Patent Literature	IPR2018-00701-1.pdf	25704069	no	76
			0cccb3d90f470a72ebf040625103f41786a5898b		
<b>Warnings:</b>					
<b>Information:</b>					
13	Non Patent Literature	NPL- DGerlach_BaseStationTransmitterArrays-1.pdf	1178114	no	5
			40084aae8a97e7b76850b397cb8979ecf932950e		

<b>Warnings:</b>					
<b>Information:</b>					
14	Non Patent Literature	NPL- IAGlover_DigitalCommunications.pdf	2554225  98451954f16c5615413af4d8c655b0174b15f798	no	23
<b>Warnings:</b>					
<b>Information:</b>					
15	Non Patent Literature	NPL-ANSI- IEEE_Standard80211_WirelessLANMediumAccessControl.pdf	19462024  11de8193f7b07e080f0a3e96cf7646fde898513d	no	432
<b>Warnings:</b>					
<b>Information:</b>					
16	Non Patent Literature	NPL- ZCFuhr_AdvancedMobilePhoneService.pdf	3300837  03f98df5c957c44dbf09ddbe6b372a771aac092a	no	29
<b>Warnings:</b>					
<b>Information:</b>					
17	Non Patent Literature	NPL-Hillebrand_GSMandUMTS.pdf	1941305  6d274a9515964f4eb713bc6a1ca3aa200c9c8a43	no	6
<b>Warnings:</b>					
<b>Information:</b>					
18	Non Patent Literature	NPL- SandraKayMiller_FacingtheChallengeofWirelessSecurity.pdf	590509  4579d61a1c74bb1a3d117cc6e1a87f0a157c3ecb	no	3
<b>Warnings:</b>					
<b>Information:</b>					
19	Non Patent Literature	NPL- Campbelletal_DesignImplementationandEvaluation-1.pdf	516795  83539c158d2c08d0f8369d54ab8927cf969451de	no	8
<b>Warnings:</b>					
<b>Information:</b>					
20	Non Patent Literature	NPL- Shimetal_ShouldtheSmartAntennaBeATrackingBeamArray-1.pdf	1150207  4a2b01e2b73e6cf586b9445698c55e7647c75a5	no	5
<b>Warnings:</b>					
<b>Information:</b>					



21	Non Patent Literature	NPL- RadioSpectrumAllocation-1.pdf	627906	no	2
			d09ce52cda0423041441d0f8d1d778158a7752fc		
<b>Warnings:</b>					
<b>Information:</b>					
22	Non Patent Literature	NPL- JackHWinters_SmartAntennas.pdf	609999	no	15
			1230acf056e62449bc9e14d983d4301b5e4d6aec		
<b>Warnings:</b>					
<b>Information:</b>					
23	Non Patent Literature	NPL- JohnLitva_DIGITALBEAMFORMING.pdf	19818020	no	132
			9bbd7c40487ac6ae9038cd560248d52e2f7689c		
<b>Warnings:</b>					
<b>Information:</b>					
24	Non Patent Literature	NPL- Liberti_SMARTANTENNASFORWIRELESSCOMMUNICATIONS.pdf	10242327	no	49
			3a7c78869a5fd8b742d9679796199a26dbbade09		
<b>Warnings:</b>					
<b>Information:</b>					
25	Non Patent Literature	NPL- ConstantineBalanis_ANTENNA THEORY-1.pdf	7080248	no	20
			36f71c77419eadbe3630fd1cbc7253af45ac868c		
<b>Warnings:</b>					
<b>Information:</b>					
26	Non Patent Literature	NPL- SCSwales_ThePerformanceEnhancementofMultibeam-1.pdf	3916330	no	17
			2143e0a1ad5b6309e91e41a8e4c469b93aa98864		
<b>Warnings:</b>					
<b>Information:</b>					
27	Non Patent Literature	NPL-IEEEStandardsBearer-1.pdf	1484125	no	16
			f8226eeefbc853302fc5876b28ff18290c14f944b		
<b>Warnings:</b>					
<b>Information:</b>					

28	Non Patent Literature	NPL-IEEE_802111997-1.pdf	13909683	no	466
			cba83211632fe09543e921ab34bf998aeda18f27		
<b>Warnings:</b>					
<b>Information:</b>					
29	Non Patent Literature	IPR2018-01016.pdf	2996329	no	87
			b2fd227858ee7ab5fec6921b5acd476f3bfbba89		
<b>Warnings:</b>					
<b>Information:</b>					
30	Non Patent Literature	IPR2018-01017.pdf	2059700	no	79
			79a34b7c3cb9a0725c0b41e3b15c9a988f0bd03		
<b>Warnings:</b>					
<b>Information:</b>					
31	Non Patent Literature	IPR2018-01018.pdf	2300805	no	65
			3b37e2321d22ebf66ce3ff1a3a23b9d7d2f5ada		
<b>Warnings:</b>					
<b>Information:</b>					
32	Non Patent Literature	NPL- OliverIbe_EssentialsATMNetworks.pdf	3853288	no	46
			1dbd7023353fd6ef1b0a0062805d9a5dc5de6052		
<b>Warnings:</b>					
The page size in the PDF is too large. The pages should be 8.5 x 11 or A4. If this PDF is submitted, the pages will be resized upon entry into the Image File Wrapper and may affect subsequent processing					
<b>Information:</b>					
33	Non Patent Literature	NPL- AndrewTanenbaum_ComputerNetworks.pdf	2887571	no	26
			26e6107e75ae5f48a0751a9a49375a3253e7d980		
<b>Warnings:</b>					
The page size in the PDF is too large. The pages should be 8.5 x 11 or A4. If this PDF is submitted, the pages will be resized upon entry into the Image File Wrapper and may affect subsequent processing					
<b>Information:</b>					
34	Non Patent Literature	IPR2018-00762-- PO_PreliminaryResponse06272018-1.pdf	15752844	no	38
			6f4d98c6e056731671bc7ba7b1380b2f79ff9e28		

<b>Warnings:</b>					
<b>Information:</b>					
35	Non Patent Literature	IPR2018-00764-- PO_PreliminaryResponse06212 018-1.pdf	18563044  e86d946e66396d2fa896af9583401379849f b2ee	no	47
<b>Warnings:</b>					
<b>Information:</b>					
36	Non Patent Literature	IPR2018-00725-- PO_PreliminaryResponse06212 018-1.pdf	13800441  5b2a1a1fe67bfb2936ad76364395af51fbc8 c854	no	35
<b>Warnings:</b>					
<b>Information:</b>					
37	Non Patent Literature	IPR2018-00701-- PO_PreliminaryResponse06152 018-1.pdf	21056741  88df7544bb3080cbb9230ca32af8e8dfa0dd db0d	no	51
<b>Warnings:</b>					
<b>Information:</b>					
<b>Total Files Size (in bytes):</b>				236946376	
<p><b>This Acknowledgement Receipt evidences receipt on the noted date by the USPTO of the indicated documents, characterized by the applicant, and including page counts, where applicable. It serves as evidence of receipt similar to a Post Card, as described in MPEP 503.</b></p> <p><b><u>New Applications Under 35 U.S.C. 111</u></b>  <b>If a new application is being filed and the application includes the necessary components for a filing date (see 37 CFR 1.53(b)-(d) and MPEP 506), a Filing Receipt (37 CFR 1.54) will be issued in due course and the date shown on this Acknowledgement Receipt will establish the filing date of the application.</b></p> <p><b><u>National Stage of an International Application under 35 U.S.C. 371</u></b>  <b>If a timely submission to enter the national stage of an international application is compliant with the conditions of 35 U.S.C. 371 and other applicable requirements a Form PCT/DO/EO/903 indicating acceptance of the application as a national stage submission under 35 U.S.C. 371 will be issued in addition to the Filing Receipt, in due course.</b></p> <p><b><u>New International Application Filed with the USPTO as a Receiving Office</u></b>  <b>If a new international application is being filed and the international application includes the necessary components for an international filing date (see PCT Article 11 and MPEP 1810), a Notification of the International Application Number and of the International Filing Date (Form PCT/RO/105) will be issued in due course, subject to prescriptions concerning national security, and the date shown on this Acknowledgement Receipt will establish the international filing date of the application.</b></p>					

Under the Paperwork Reduction Act of 1995, no persons are required to respond to a collection of information unless it contains a valid OMB control number.

<b>Request for Continued Examination (RCE) Transmittal</b>	Application Number	15/495,539
	Filing Date	April 24, 2017
	First Named Inventor	Marcus Da Silva
	Art Unit	2631
	Examiner Name	Mckie, Gina M.
	Attorney Docket Number	1640-001.203

Address to:  
Mail Stop RCE  
Commissioner for Patents  
P.O. Box 1450  
Alexandria, VA 22313-1450

**This is a Request for Continued Examination (RCE) under 37 CFR 1.114 of the above-identified application.**  
Request for Continued Examination (RCE) practice under 37 CFR 1.114 does not apply to any utility or plant application filed prior to June 8, 1995, or to any design application. See Instruction Sheet for RCEs (not to be submitted to the USPTO) on page 2.

1. **Submission required under 37 CFR 1.114** Note: If the RCE is proper, any previously filed unentered amendments and amendments enclosed with the RCE will be entered in the order in which they were filed unless applicant instructs otherwise. If applicant does not wish to have any previously filed unentered amendment(s) entered, applicant must request non-entry of such amendment(s).
- a.  Previously submitted. If a final Office action is outstanding, any amendments filed after the final Office action may be considered as a submission even if this box is not checked.
- i.  Consider the arguments in the Appeal Brief or Reply Brief previously filed on \_\_\_\_\_
- ii.  Other \_\_\_\_\_
- b.  Enclosed
- i.  Amendment/Reply
- ii.  Affidavit(s)/ Declaration(s)
- iii.  Information Disclosure Statement (IDS)
- iv.  Other \_\_\_\_\_
2. **Miscellaneous**
- a.  Suspension of action on the above-identified application is requested under 37 CFR 1.103(c) for a period of \_\_\_\_\_ months. (Period of suspension shall not exceed 3 months; Fee under 37 CFR 1.17(i) required)
- b.  Other \_\_\_\_\_
3. **Fees** The RCE fee under 37 CFR 1.17(e) is required by 37 CFR 1.114 when the RCE is filed. The Director is hereby authorized to charge the following fees, any underpayment of fees, or credit any overpayments, to Deposit Account No. 11-1159.
- a.
- i.  RCE fee required under 37 CFR 1.17(e)
- ii.  Extension of time fee (37 CFR 1.136 and 1.17)
- iii.  Other \_\_\_\_\_
- b.  Check in the amount of \$ \_\_\_\_\_ enclosed
- c.  Payment by credit card (Form PTO-2038 enclosed)
- d.  Payment by EFS-Web

**WARNING: Information on this form may become public. Credit card information should not be included on this form. Provide credit card information and authorization on PTO-2038.**

**SIGNATURE OF APPLICANT, ATTORNEY, OR AGENT REQUIRED**

Signature	/Glen L Nuttall/	Date	July 25, 2018
Name (Print/Type)	Glen L. Nuttall	Registration No.	46,188

**CERTIFICATE OF MAILING OR TRANSMISSION**

I hereby certify that this correspondence is being EFS-Web transmitted to the United States Patent and Trademark Office (USPTO), deposited with the United States Postal Service with sufficient postage as first class mail in an envelope addressed to: Mail Stop RCE, Commissioner for Patents, P. O. Box 1450, Alexandria, VA 22313-1450 or facsimile transmitted to the USPTO on the date shown below.

Signature	Date
Name (Print/Type)	

This collection of information is required by 37 CFR 1.114. The information is required to obtain or retain a benefit by the public which is to file (and by the USPTO to process) an application. Confidentiality is governed by 35 U.S.C. 122 and 37 CFR 1.11 and 1.14. This collection is estimated to take 12 minutes to complete, including gathering, preparing, and submitting the completed application form to the USPTO. Time will vary depending upon the individual case. Any comments on the amount of time you require to complete this form and/or suggestions for reducing this burden, should be sent to the Chief Information Officer, U.S. Patent and Trademark Office, U.S. Department of Commerce, P.O. Box 1450, Alexandria, VA 22313-1450. DO NOT SEND FEES OR COMPLETED FORMS TO THIS ADDRESS. SEND TO: Mail Stop RCE, Commissioner for Patents, P.O. Box 1450, Alexandria, VA 22313-1450.

*If you need assistance in completing the form, call 1-800-PTO-9199 and select option 2.*

IN THE UNITED STATES PATENT AND TRADEMARK OFFICE

Applicants: Marcus Da Silva et al.  
Title: DIRECTED WIRELESS COMMUNICATION  
Serial No.: 15/495,539 Filed: April 24, 2017  
Examiner: McKie, Gina M. Group Art Unit: 2631  
Attorney Docket No.: 1640-001.203

---

**CERTIFICATE OF EFS-WEB TRANSMISSION  
UNDER 37 CFR § 1.8**

I hereby certify that the enclosed Request for Continued Examination Transmittal (1 page); Office Action Response (7 pages); and Payment by Credit Card are being transmitted to the United States Patent and Trademark Office from the Pacific Time Zone via EFS-Web on July 25, 2018.

Date: July 25, 2018

/Glen L. Nuttall/

Glen L. Nuttall

Mailing Address:

**KLEIN, O'NEILL & SINGH, LLP (Customer No.: 22145)**  
16755 Von Karman Avenue, Suite 275  
Irvine, California 92606  
Tel: 949-955-1920  
Fax: 949-955-1921

## Electronic Patent Application Fee Transmittal

<b>Application Number:</b>	15495539			
<b>Filing Date:</b>	24-Apr-2017			
<b>Title of Invention:</b>	DIRECTED WIRELESS COMMUNICATION			
<b>First Named Inventor/Applicant Name:</b>	Marcus Da Silva			
<b>Filer:</b>	Glen L. Nuttall			
<b>Attorney Docket Number:</b>	1640-001.203			
Filed as Small Entity				
<b>Filing Fees for Utility under 35 USC 111(a)</b>				
<b>Description</b>	<b>Fee Code</b>	<b>Quantity</b>	<b>Amount</b>	<b>Sub-Total in USD(\$)</b>
<b>Basic Filing:</b>				
<b>Pages:</b>				
<b>Claims:</b>				
<b>Miscellaneous-Filing:</b>				
<b>Petition:</b>				
<b>Patent-Appeals-and-Interference:</b>				
<b>Post-Allowance-and-Post-Issuance:</b>				
<b>Extension-of-Time:</b>				

Description	Fee Code	Quantity	Amount	Sub-Total in USD(\$)
Extension - 3 months with \$0 paid	2253	1	700	700
<b>Miscellaneous:</b>				
RCE- 1ST REQUEST	2801	1	650	650
<b>Total in USD (\$)</b>				<b>1350</b>

## Electronic Acknowledgement Receipt

<b>EFS ID:</b>	33286570
<b>Application Number:</b>	15495539
<b>International Application Number:</b>	
<b>Confirmation Number:</b>	1050
<b>Title of Invention:</b>	DIRECTED WIRELESS COMMUNICATION
<b>First Named Inventor/Applicant Name:</b>	Marcus Da Silva
<b>Customer Number:</b>	22145
<b>Filer:</b>	Glen L. Nuttall
<b>Filer Authorized By:</b>	
<b>Attorney Docket Number:</b>	1640-001.203
<b>Receipt Date:</b>	26-JUL-2018
<b>Filing Date:</b>	24-APR-2017
<b>Time Stamp:</b>	02:05:07
<b>Application Type:</b>	Utility under 35 USC 111(a)

### Payment information:

Submitted with Payment	yes
Payment Type	CARD
Payment was successfully received in RAM	\$1350
RAM confirmation Number	072618INTEFSW02094700
Deposit Account	
Authorized User	

The Director of the USPTO is hereby authorized to charge indicated fees and credit any overpayment as follows:



<b>File Listing:</b>					
<b>Document Number</b>	<b>Document Description</b>	<b>File Name</b>	<b>File Size(Bytes)/ Message Digest</b>	<b>Multi Part /.zip</b>	<b>Pages (if appl.)</b>
1		doc08676520180725231047.pdf	494437  052858b432cdf8bcf91b899900bbed51f0b6ff2f	yes	9
<b>Multipart Description/PDF files in .zip description</b>					
	<b>Document Description</b>		<b>Start</b>		<b>End</b>
	Response After Final Action		3		9
	Request for Continued Examination (RCE)		2		2
	Miscellaneous Incoming Letter		1		1
<b>Warnings:</b>					
The page size in the PDF is too large. The pages should be 8.5 x 11 or A4. If this PDF is submitted, the pages will be resized upon entry into the Image File Wrapper and may affect subsequent processing					
<b>Information:</b>					
2	Fee Worksheet (SB06)	fee-info.pdf	32180  c7b28b036fc14365d277ad5179ce44ef8a1155e	no	2
<b>Warnings:</b>					
<b>Information:</b>					
<b>Total Files Size (in bytes):</b>			526617		

**This Acknowledgement Receipt evidences receipt on the noted date by the USPTO of the indicated documents, characterized by the applicant, and including page counts, where applicable. It serves as evidence of receipt similar to a Post Card, as described in MPEP 503.**

**New Applications Under 35 U.S.C. 111**

**If a new application is being filed and the application includes the necessary components for a filing date (see 37 CFR 1.53(b)-(d) and MPEP 506), a Filing Receipt (37 CFR 1.54) will be issued in due course and the date shown on this Acknowledgement Receipt will establish the filing date of the application.**

**National Stage of an International Application under 35 U.S.C. 371**

**If a timely submission to enter the national stage of an international application is compliant with the conditions of 35 U.S.C. 371 and other applicable requirements a Form PCT/DO/EO/903 indicating acceptance of the application as a national stage submission under 35 U.S.C. 371 will be issued in addition to the Filing Receipt, in due course.**

**New International Application Filed with the USPTO as a Receiving Office**

**If a new international application is being filed and the international application includes the necessary components for an international filing date (see PCT Article 11 and MPEP 1810), a Notification of the International Application Number and of the International Filing Date (Form PCT/RO/105) will be issued in due course, subject to prescriptions concerning national security, and the date shown on this Acknowledgement Receipt will establish the international filing date of the application.**

Serial No.: 15/495,539  
Attorney Docket No.: 1640-001.203

**IN THE UNITED STATES PATENT AND TRADEMARK OFFICE**

Applicant	: Marcus DaSilva
Serial No.	: 15/495,539
Filed	: April 24, 2017
For	: DIRECTED WIRELESS COMMUNICATION
Examiner	: McKie, Gina M
Art Unit	: 2631
Confirmation No.	: 1050

**OFFICE ACTION RESPONSE**

Commissioner for Patents  
P.O. Box 1450  
Alexandria, VA 22313-1450

Commissioner:

In response to the Office action transmitted January 24, 2018, and in conjunction with the Request for Continued Examination filed herewith, please reconsider the above-captioned application in light of the following remarks, which begin on page 2 of this paper.

## **REMARKS**

By this paper none of the claims have been amended. As such, Claims 1-20 remain pending for consideration in this application.

The Office Action rejected Claims 1-20 under 35 USC 103 as being unpatentable over US Publication US 2002/0158801 to Crilly in view of US Pat. 6,714,584 to Ishii. Applicant respectfully traverses the rejection, contending that Crilly is not prior art to the present application.

The present application claims priority to US Provisional Application No. 62/423,660, which was filed November 4, 2002. The Provisional application includes a compilation of several documents, labeled Appendices A-L on page 2. These documents describe aspects and embodiments of Applicant's invention existing at the time the particular document was written.

Document A, at page A-71, lists several "References" used in compiling Document A. Included in the References list is "[2] Ed Casas, 'Beamforming for LittleJoe', ViVATO Technical Report, Feb 1, 2002", which is Document C of the Provisional. At least Document C describes aspects of Applicant's invention that had been invented at least as early as February, 2002, which is well before Crilly was published (October 31, 2002). As such, at least the disclosure in Document C was invented before Crilly was published, and Crilly is not prior art to such disclosure.

As demonstrated by Document C, at least the limitations that the Office Action contends are taught by Crilly were invented by Applicant prior to Crilly's publication.

For example, with respect to independent Claim 1 (and OA at pp.6-7) Doc C describes:

- an antenna
  - see C-2, section 1.2.
- a transceiver operatively coupled to the antenna and configured to transmit and receive electromagnetic signals using the antenna
  - see C-1 – C-2, C-4 ("each array element [can] generate the receive and transmit beams") and throughout Document C.
- a processor operatively coupled to the transceiver, the processor configured to:
  - C-1 and C-2, including Fig. 1 disclose a PC
- receive a first signal transmission for a remote station via the antenna and a second signal transmission from the remote station via the antenna

- C-3: "The signal received by the array elements will be the vector sum of signals arriving by many paths." C-3 also refers to the "arrival of signals from the desired and undesired users".
- determine first signal information for the first signal transmission
  - C-4: "The beamforming application uses the signal strength information derived from packet receptions by the 'searcher' receivers."
- determine second signal information for the second signal transmission, wherein the second signal information is different than the first signal information
  - C-4: "The beamforming application uses the signal strength information derived from packet receptions by the 'searcher' receivers. However, not all of these receivers will correctly receive each packet." Also, "Each beam points in a different direction . . . ."
- determine a set of weighting values based on the first signal information and the second signal information, wherein the set of weighting values is configured to be used by the remote station to construct one or more beam-formed transmission signals
  - C-4: "The beamforming algorithm computes the beamforming weights for a particular client (identified by its wireless MAC address) and stores it in a table which is made available to the application running the modified (polling) MAC protocol on 'card 13'".
- cause the transceiver to generate a third signal comprising content based on the set of weighting values
  - C-1: "This signal level information is used to compute the complex weights for a second RF beamformer. This so-called 'card 13' beamformer allows independent complex weights on each array element. This beamformer is connected to an additional WLAN card which is the one actually used for communication (it can transmit and receive)."
  - C-4: "The beamforming algorithm computes the beamforming weights for a particular client (identified by its wireless MAC address) and stores it in a table which is made available to the application running the modified (polling) MAC protocol on 'card 13'".

As demonstrated above, Document C of the Provisional application teaches at least the limitations that the Office Action contends are taught by Crilly in connection with the rejection of Claim 1. Since Document C demonstrates aspects invented by Applicant prior to Crilly's publication, Crilly is not prior art at least for the invention recited in Claim 1. As such, Applicant

respectfully requests that the rejection of Claim 1, and Claims 2-8 which depend therefrom, be withdrawn.

With respect to independent Claim 9 (and OA at pp. 14-15) Doc C describes:

- receiving a first signal transmission from a remote station via a first antenna element of an antenna and a second signal transmission from the remote station via a second antenna element of the antenna
  - C-3: “The signal received by the array elements will be the vector sum of signals arriving by many paths.” C-3 also refers to the “arrival of signals from the desired and undesired users”.
- determining first signal information for the first signal transmission
  - C-4: “The beamforming application uses the signal strength information derived from packet receptions by the ‘searcher’ receivers.”
- determining second signal information for the second signal transmission, wherein the second signal information is different than the first signal information
  - C-4: “The beamforming application uses the signal strength information derived from packet receptions by the ‘searcher’ receivers. However, not all of these receivers will correctly receive each packet.” Also, “Each beam points in a different direction . . . .”
- determining a set of weighting values based on the first signal information and the second signal information, wherein the set of weighting values is configured to be used by the remote station to construct one or more beam-formed transmission signals
  - C-4: “The beamforming algorithm computes the beamforming weights for a particular client (identified by its wireless MAC address) and stores it in a table which is made available to the application running the modified (polling) MAC protocol on ‘card 13’”.
- transmitting to the remote station a third signal comprising content based on the set of weighting values
  - C-1: “This signal level information is used to compute the complex weights for a second RF beamformer. This so-called ‘card 13’ beamformer allows independent complex weights on each array element. This beamformer is connected to an additional WLAN card which is the one actually used for communication (it can transmit and receive).”

- C-4: “The beamforming algorithm computes the beamforming weights for a particular client (identified by its wireless MAC address) and stores it in a table which is made available to the application running the modified (polling) MAC protocol on ‘card 13’”.

As demonstrated above, Document C of the Provisional application teaches at least the limitations that the Office Action contends are taught by Crilly in connection with the rejection of Claim 9. Since Document C demonstrates aspects invented by Applicant prior to Crilly’s publication, Crilly is not prior art at least for the invention recited in Claim 9. As such, Applicant respectfully requests that the rejection of Claim 1, and Claims 10-16 which depend therefrom, be withdrawn.

With respect to independent Claim 17 (and OA at pp. 21-23) Doc C describes:

- an antenna
  - see C-2, section 1.2.
- a transceiver operatively coupled to the antenna
  - see C-1 – C-2, C-4 (“each array element [can] generate the receive and transmit beams”) and throughout Document C.
- a processor operatively coupled to the transceiver, the processor configured to:
  - C-1 and C-2, including Fig. 1 disclose a PC
- receive a first signal transmission via the antenna, the first signal transmission comprising first signal information
  - C-3: “The signal received by the array elements will be the vector sum of signals arriving by many paths.” C-3 also refers to the “arrival of signals from the desired and undesired users”.
  - C-4: “The beamforming application uses the signal strength information derived from packet receptions by the ‘searcher’ receivers.”
- receive a second signal transmission via the antenna, the second signal transmission comprising second signal information
  - C-3: “The signal received by the array elements will be the vector sum of signals arriving by many paths.” C-3 also refers to the “arrival of signals from the desired and undesired users”.
  - C-4: “The beamforming application uses the signal strength information derived from packet receptions by the ‘searcher’ receivers.”
- determine a set of weighting values based on the first signal information and the second signal information, wherein the set of weighting values is configured to be

used by the remote station to construct one or more beam-formed transmission signals

- C-4: "The beamforming algorithm computes the beamforming weights for a particular client (identified by its wireless MAC address) and stores it in a table which is made available to the application running the modified (polling) MAC protocol on 'card 13'".
- cause the transceiver to generate a third signal comprising content based on the set of weighting values
  - C-1: "This signal level information is used to compute the complex weights for a second RF beamformer. This so-called 'card 13' beamformer allows independent complex weights on each array element. This beamformer is connected to an additional WLAN card which is the one actually used for communication (it can transmit and receive)."
  - C-4: "The beamforming algorithm computes the beamforming weights for a particular client (identified by its wireless MAC address) and stores it in a table which is made available to the application running the modified (polling) MAC protocol on 'card 13'".

As demonstrated above, Document C of the Provisional application teaches at least the limitations that the Office Action contends are taught by Crilly in connection with the rejection of Claim 17. Since Document C demonstrates aspects invented by Applicant prior to Crilly's publication, Crilly is not prior art at least for the invention recited in Claim 17. As such, Applicant respectfully requests that the rejection of Claim 17, and Claims 18-20 which depend therefrom, be withdrawn.

#### Conclusion

For the foregoing reasons, it is respectfully submitted that the rejections set forth in the outstanding Office action are inapplicable to the current claims. Accordingly, issuance of a Notice of Allowance is requested.



Serial No.: 15/495,539  
Attorney Docket No.: 1640-001.203

Please charge any additional fees, including any fees for additional extension of time, or credit overpayment to Deposit Account No. 11-1159.

Respectfully submitted,

Klein, O'Neill & Singh, LLP

Dated: July 25, 2018

By /Glen L Nuttall/  
Glen L Nuttall, Reg. No. 46,188  
Telephone: (949) 955-1920

Klein, O'Neill & Singh, LLP  
16755 Von Karman, Suite 275  
Irvine, CA 92606  
T (949) 955-1920  
F (949) 955-1921



UNITED STATES PATENT AND TRADEMARK OFFICE

UNITED STATES DEPARTMENT OF COMMERCE  
United States Patent and Trademark Office  
Address: COMMISSIONER FOR PATENTS  
P.O. Box 1450  
Alexandria, Virginia 22313-1450  
www.uspto.gov

APPLICATION NUMBER	FILING OR 371(C) DATE	FIRST NAMED APPLICANT	ATTY. DOCKET NO./TITLE
15/495,539	04/24/2017	Marcus Da Silva	1640-001.203

**CONFIRMATION NO. 1050**

**POWER OF ATTORNEY NOTICE**

22145  
KLEIN, O'NEILL & SINGH, LLP  
16755 VON KARMAN AVENUE  
SUITE 275  
IRVINE, CA 92606



Date Mailed: 03/01/2018

**NOTICE REGARDING CHANGE OF POWER OF ATTORNEY**

This is in response to the Power of Attorney filed 02/27/2018.

- The Power of Attorney to you in this application has been revoked by the applicant. Future correspondence will be mailed to the new address of record(37 CFR 1.33).

Questions about the contents of this notice and the requirements it sets forth should be directed to the Office of Data Management, Application Assistance Unit, at (571) 272-4000 or (571) 272-4200 or 1-888-786-0101.

/sleutchit/



UNITED STATES PATENT AND TRADEMARK OFFICE

UNITED STATES DEPARTMENT OF COMMERCE  
United States Patent and Trademark Office  
Address: COMMISSIONER FOR PATENTS  
P.O. Box 1450  
Alexandria, Virginia 22313-1450  
www.uspto.gov

APPLICATION NUMBER	FILING OR 371(C) DATE	FIRST NAMED APPLICANT	ATTY. DOCKET NO./TITLE
15/495,539	04/24/2017	Marcus Da Silva	1640-001.203

**CONFIRMATION NO. 1050**

**POA ACCEPTANCE LETTER**

22145  
KLEIN, O'NEILL & SINGH, LLP  
16755 VON KARMAN AVENUE  
SUITE 275  
IRVINE, CA 92606



Date Mailed: 03/01/2018

**NOTICE OF ACCEPTANCE OF POWER OF ATTORNEY**

This is in response to the Power of Attorney filed 02/27/2018.

The Power of Attorney in this application is accepted. Correspondence in this application will be mailed to the above address as provided by 37 CFR 1.33.

Questions about the contents of this notice and the requirements it sets forth should be directed to the Office of Data Management, Application Assistance Unit, at (571) 272-4000 or (571) 272-4200 or 1-888-786-0101.

/sleutchit/

Under the Paperwork Reduction Act of 1995, no persons are required to respond to a collection of information unless it displays a valid OMB control number

## POWER OF ATTORNEY BY APPLICANT

I hereby revoke all previous powers of attorney given in the application identified in either the attached transmittal letter or the boxes below.

Application Number	Filing Date

(Note: The boxes above may be left blank if information is provided on form PTO/AIA/82A.)

- I hereby appoint the Patent Practitioner(s) associated with the following Customer Number as my/our attorney(s) or agent(s), and to transact all business in the United States Patent and Trademark Office connected therewith for the application referenced in the attached transmittal letter (form PTO/AIA/82A) or identified above: 22145
- OR
- I hereby appoint Practitioner(s) named in the attached list (form PTO/AIA/82C) as my/our attorney(s) or agent(s), and to transact all business in the United States Patent and Trademark Office connected therewith for the patent application referenced in the attached transmittal letter (form PTO/AIA/82A) or identified above. (Note: Complete form PTO/AIA/82C.)

Please recognize or change the correspondence address for the application identified in the attached transmittal letter or the boxes above to:

- The address associated with the above-mentioned Customer Number
- OR
- The address associated with Customer Number:
- OR

Firm or Individual Name				
Address				
City	State	Zip		
Country				
Telephone	Email			

I am the Applicant (if the Applicant is a juristic entity, list the Applicant name in the box):

XR Communications, LLC d/b/a Vivato Technologies

- Inventor or Joint Inventor (title not required below)
- Legal Representative of a Deceased or Legally Incapacitated Inventor (title not required below)
- Assignee or Person to Whom the Inventor is Under an Obligation to Assign (provide signer's title if applicant is a juristic entity)
- Person Who Otherwise Shows Sufficient Proprietary Interest (e.g., a petition under 37 CFR 1.46(b)(2) was granted in the application or is concurrently being filed with this document) (provide signer's title if applicant is a juristic entity)

**SIGNATURE of Applicant for Patent**

The undersigned (whose title is supplied below) is authorized to act on behalf of the applicant (e.g., where the applicant is a juristic entity).

Signature	Date (Optional)	1/10/2015
Name	Kai Hansen	
Title	Managing Member	

**NOTE:** Signature - This form must be signed by the applicant in accordance with 37 CFR 1.33. See 37 CFR 1.4 for signature requirements and certifications. If more than one applicant, use multiple forms.

Total of \_\_\_\_\_ forms are submitted.

This collection of information is required by 37 CFR 1.131, 1.32, and 1.33. The information is required to obtain or retain a benefit by the public which is to file (and by the USPTO to process) an application. Confidentiality is governed by 35 U.S.C. 122 and 37 CFR 1.11 and 1.14. This collection is estimated to take 3 minutes to complete, including gathering, preparing, and submitting the completed application form to the USPTO. Time will vary depending upon the individual case. Any comments on the amount of time you require to complete this form and/or suggestions for reducing this burden, should be sent to the Chief Information Officer, U.S. Patent and Trademark Office, U.S. Department of Commerce, P.O. Box 1450, Alexandria, VA 22313-1450. DO NOT SEND FEES OR COMPLETED FORMS TO THIS ADDRESS. SEND TO: Commissioner for Patents, P.O. Box 1450, Alexandria, VA 22313-1450.

*If you need assistance in completing the form, call 1-800-PTO-9199 and select option 2.*

## Electronic Acknowledgement Receipt

<b>EFS ID:</b>	31908581
<b>Application Number:</b>	15495539
<b>International Application Number:</b>	
<b>Confirmation Number:</b>	1050
<b>Title of Invention:</b>	DIRECTED WIRELESS COMMUNICATION
<b>First Named Inventor/Applicant Name:</b>	Marcus Da Silva
<b>Customer Number:</b>	22145
<b>Filer:</b>	Glen L. Nuttall/Mariel Boyan
<b>Filer Authorized By:</b>	Glen L. Nuttall
<b>Attorney Docket Number:</b>	1640-001.203
<b>Receipt Date:</b>	27-FEB-2018
<b>Filing Date:</b>	24-APR-2017
<b>Time Stamp:</b>	20:10:57
<b>Application Type:</b>	Utility under 35 USC 111(a)

### Payment information:

Submitted with Payment	no
------------------------	----

### File Listing:

Document Number	Document Description	File Name	File Size(Bytes)/ Message Digest	Multi Part /.zip	Pages (if appl.)
1		1640-001-203-- POAAsFiled02272018.pdf	209878  724297203efe4ec3431583166dcc38e89f8b ba52	yes	2

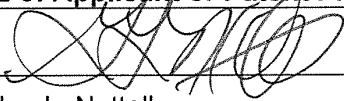
<b>Multipart Description/PDF files in .zip description</b>		
<b>Document Description</b>	<b>Start</b>	<b>End</b>
Transmittal Letter	1	1
Power of Attorney	2	2
<b>Warnings:</b>		
The page size in the PDF is too large. The pages should be 8.5 x 11 or A4. If this PDF is submitted, the pages will be resized upon entry into the Image File Wrapper and may affect subsequent processing		
<b>Information:</b>		
<b>Total Files Size (in bytes):</b>		209878
<p><b>This Acknowledgement Receipt evidences receipt on the noted date by the USPTO of the indicated documents, characterized by the applicant, and including page counts, where applicable. It serves as evidence of receipt similar to a Post Card, as described in MPEP 503.</b></p> <p><b><u>New Applications Under 35 U.S.C. 111</u></b>  <b>If a new application is being filed and the application includes the necessary components for a filing date (see 37 CFR 1.53(b)-(d) and MPEP 506), a Filing Receipt (37 CFR 1.54) will be issued in due course and the date shown on this Acknowledgement Receipt will establish the filing date of the application.</b></p> <p><b><u>National Stage of an International Application under 35 U.S.C. 371</u></b>  <b>If a timely submission to enter the national stage of an international application is compliant with the conditions of 35 U.S.C. 371 and other applicable requirements a Form PCT/DO/EO/903 indicating acceptance of the application as a national stage submission under 35 U.S.C. 371 will be issued in addition to the Filing Receipt, in due course.</b></p> <p><b><u>New International Application Filed with the USPTO as a Receiving Office</u></b>  <b>If a new international application is being filed and the international application includes the necessary components for an international filing date (see PCT Article 11 and MPEP 1810), a Notification of the International Application Number and of the International Filing Date (Form PCT/RO/105) will be issued in due course, subject to prescriptions concerning national security, and the date shown on this Acknowledgement Receipt will establish the international filing date of the application.</b></p>		

Under the Paperwork Reduction Act of 1995, no persons are required to respond to a collection of information unless it displays a valid OMB control number.

## TRANSMITTAL FOR POWER OF ATTORNEY TO ONE OR MORE REGISTERED PRACTITIONERS

NOTE: This form is to be submitted with the Power of Attorney by Applicant form (PTO/AIA/82B) to identify the application to which the Power of Attorney is directed, in accordance with 37 CFR 1.5, unless the application number and filing date are identified in the Power of Attorney by Applicant form. If neither form PTO/AIA/82A nor form PTO/AIA82B identifies the application to which the Power of Attorney is directed, the Power of Attorney will not be recognized in the application.

Application Number	15/495,539
Filing Date	April 24, 2017
First Named Inventor	Marcus Da Silva
Title	DIRECTED WIRELESS COMMUNICATION
Art Unit	2631
Examiner Name	Mckie, Gina M.
Attorney Docket Number	1640-001.203

SIGNATURE of Applicant or Patent Practitioner			
Signature		Date (Optional)	February 27, 2018
Name	Glen L. Nuttall	Registration Number	46,188
Title (if Applicant is a juristic entity)			
Applicant Name (if Applicant is a juristic entity)			
<p><b>NOTE:</b> This form must be signed in accordance with 37 CFR 1.33. See 37 CFR 1.4(d) for signature requirements and certifications. If more than one applicant, use multiple forms.</p>			
<input type="checkbox"/> *Total of _____ forms are submitted.			

This collection of information is required by 37 CFR 1.131, 1.32, and 1.33. The information is required to obtain or retain a benefit by the public which is to file (and by the USPTO to process) an application. Confidentiality is governed by 35 U.S.C. 122 and 37 CFR 1.11 and 1.14. This collection is estimated to take 3 minutes to complete, including gathering, preparing, and submitting the completed application form to the USPTO. Time will vary depending upon the individual case. Any comments on the amount of time you require to complete this form and/or suggestions for reducing this burden, should be sent to the Chief Information Officer, U.S. Patent and Trademark Office, U.S. Department of Commerce, P.O. Box 1450, Alexandria, VA 22313-1450. DO NOT SEND FEES OR COMPLETED FORMS TO THIS ADDRESS. SEND TO: Commissioner for Patents, P.O. Box 1450, Alexandria, VA 22313-1450.

*If you need assistance in completing the form, call 1-800-PTO-9199 and select option 2.*



UNITED STATES PATENT AND TRADEMARK OFFICE

UNITED STATES DEPARTMENT OF COMMERCE  
United States Patent and Trademark Office  
Address: COMMISSIONER FOR PATENTS  
P. O. Box 1450  
Alexandria, Virginia 22313-1450  
www.uspto.gov

APPLICATION NO.	FILING DATE	FIRST NAMED INVENTOR	ATTORNEY DOCKET NO.	CONFIRMATION NO.
15/495,539	04/24/2017	Marcus Da Silva	1640-001.203	1050

22145 7590 01/25/2018  
KLEIN, O'NEILL & SINGH, LLP  
16755 VON KARMAN AVENUE  
SUITE 275  
IRVINE, CA 92606

EXAMINER
----------

MCKIE, GINA M

ART UNIT	PAPER NUMBER
----------	--------------

2631

NOTIFICATION DATE	DELIVERY MODE
-------------------	---------------

01/25/2018

ELECTRONIC

**Please find below and/or attached an Office communication concerning this application or proceeding.**

The time period for reply, if any, is set in the attached communication.

Notice of the Office communication was sent electronically on above-indicated "Notification Date" to the following e-mail address(es):

KOS\_Docketing@koslaw.com



<b>Office Action Summary</b>	<b>Application No.</b> 15/495,539	<b>Applicant(s)</b> DA SILVA ET AL.	
	<b>Examiner</b> GINA MCKIE	<b>Art Unit</b> 2631	<b>AIA (First Inventor to File) Status</b> No

**-- The MAILING DATE of this communication appears on the cover sheet with the correspondence address --**

**Period for Reply**

A SHORTENED STATUTORY PERIOD FOR REPLY IS SET TO EXPIRE 3 MONTHS FROM THE MAILING DATE OF THIS COMMUNICATION.

- Extensions of time may be available under the provisions of 37 CFR 1.136(a). In no event, however, may a reply be timely filed after SIX (6) MONTHS from the mailing date of this communication.
- If NO period for reply is specified above, the maximum statutory period will apply and will expire SIX (6) MONTHS from the mailing date of this communication.
- Failure to reply within the set or extended period for reply will, by statute, cause the application to become ABANDONED (35 U.S.C. § 133). Any reply received by the Office later than three months after the mailing date of this communication, even if timely filed, may reduce any earned patent term adjustment. See 37 CFR 1.704(b).

**Status**

- 1)  Responsive to communication(s) filed on 05 October 2017.  
 A declaration(s)/affidavit(s) under **37 CFR 1.130(b)** was/were filed on \_\_\_\_\_.
- 2a)  This action is **FINAL**.                      2b)  This action is non-final.
- 3)  An election was made by the applicant in response to a restriction requirement set forth during the interview on \_\_\_\_\_; the restriction requirement and election have been incorporated into this action.
- 4)  Since this application is in condition for allowance except for formal matters, prosecution as to the merits is closed in accordance with the practice under *Ex parte Quayle*, 1935 C.D. 11, 453 O.G. 213.

**Disposition of Claims\***

- 5)  Claim(s) 1-20 is/are pending in the application.  
5a) Of the above claim(s) \_\_\_\_\_ is/are withdrawn from consideration.
- 6)  Claim(s) \_\_\_\_\_ is/are allowed.
- 7)  Claim(s) 1-20 is/are rejected.
- 8)  Claim(s) \_\_\_\_\_ is/are objected to.
- 9)  Claim(s) \_\_\_\_\_ are subject to restriction and/or election requirement.

\* If any claims have been determined allowable, you may be eligible to benefit from the **Patent Prosecution Highway** program at a participating intellectual property office for the corresponding application. For more information, please see [http://www.uspto.gov/patents/init\\_events/pph/index.jsp](http://www.uspto.gov/patents/init_events/pph/index.jsp) or send an inquiry to [PPHfeedback@uspto.gov](mailto:PPHfeedback@uspto.gov).

**Application Papers**

- 10)  The specification is objected to by the Examiner.
- 11)  The drawing(s) filed on 05 October 2017 is/are: a)  accepted or b)  objected to by the Examiner.  
Applicant may not request that any objection to the drawing(s) be held in abeyance. See 37 CFR 1.85(a).  
Replacement drawing sheet(s) including the correction is required if the drawing(s) is objected to. See 37 CFR 1.121(d).

**Priority under 35 U.S.C. § 119**

- 12)  Acknowledgment is made of a claim for foreign priority under 35 U.S.C. § 119(a)-(d) or (f).

**Certified copies:**

- a)  All    b)  Some\*\*    c)  None of the:
1.  Certified copies of the priority documents have been received.
  2.  Certified copies of the priority documents have been received in Application No. \_\_\_\_\_.
  3.  Copies of the certified copies of the priority documents have been received in this National Stage application from the International Bureau (PCT Rule 17.2(a)).

\*\* See the attached detailed Office action for a list of the certified copies not received.

**Attachment(s)**

- 1)  Notice of References Cited (PTO-892)
- 2)  Information Disclosure Statement(s) (PTO/SB/08a and/or PTO/SB/08b)  
Paper No(s)/Mail Date \_\_\_\_\_.
- 3)  Interview Summary (PTO-413)  
Paper No(s)/Mail Date. \_\_\_\_\_.
- 4)  Other: \_\_\_\_\_.

## **DETAILED ACTION**

### ***Notice of Pre-AIA or AIA Status***

1. The present application is being examined under the pre-AIA first to invent provisions.

### ***Response to Amendment***

2. Acknowledgement is made of the amendment filed October 05, 2017. Claims 1-20 remain pending in the application.

- No claims are currently amended.
- No claims have been canceled.
- No claims are new.

### ***Response to Arguments***

3. Applicant's arguments filed October 05, 2017 with respect to the rejection of claims 1-20 is/are rejected under pre-AIA 35 U.S.C. 103(a) as being unpatentable over Crilly, Jr. et al. (US 2002/0158801 A1) in view of Ishii et al. (US 6,714,584) have been fully considered but they are not persuasive. The examiner has thoroughly reviewed the applicant's arguments, however, firmly believes that the cited reference reasonably and properly meets the claimed limitation as rejected.

The applicant is reminded that the examiner is entitled to give the broadest reasonable interpretation to the language of the claim. A broad interpretation of a claim

by USPTO personnel will reduce the possibility that the claim, when issued, will be interpreted more broadly than is justified or intended.

The applicant is reminded that the rejection is made based on the entire content of the cited prior art.

**(1) Applicant's arguments:** "However, the cited portions of Ishii do not disclose or suggest receiving signal components from the same transmitter. In fact, Ishii discloses that the "present invention relates to CDMA (Code Division Multiple Access) adaptive antenna . . . for separating and synthesizing a plural of desired signal components incoming at a plural of different timings and from a *plural of different directions at each timing.*" *Id.*, column 1, lines 8-13 (emphasis added). In Ishii, signal components come from a plurality of different directions, and are thus associated with *different* transmitters. In contrast, claim 1 recites "receive a first signal transmission from *a* remote station via the antenna and a second signal transmission from *the* remote station" (emphasis added).," (see REMARKS, page 11, line 23 – page 12, line 6).

**Examiner's response:**

In response to applicant's arguments against the references individually, one cannot show nonobviousness by attacking references individually where the rejections are based on combinations of references. See *In re Keller*, 642 F.2d 413, 208 USPQ 871 (CCPA 1981); *In re Merck & Co.*, 800 F.2d 1091, 231 USPQ 375 (Fed. Cir. 1986).

The combination of Crilly, Jr. and Ishii discloses receive a first signal transmission from a remote station via the antenna and a second signal transmission from *the* remote station.”

Crilly discloses receive a first signal transmission from a remote station via the antenna and a second signal transmission via the antenna (see Crilly FIG. 4, paragraph [0091]; **These signals, both desired and undesired, are collected by receiving elements within antenna array 110 and are eventually provided to control logic 110.**);

Crilly does not specifically disclose “receive a first signal transmission from a remote station via the antenna and a second signal transmission from the remote station via the antenna simultaneously.”

However, Ishii in the same field of endeavor discloses receiving a first signal transmission from a remote station via the antenna and a second signal transmission from the remote station via the antenna simultaneously (see Ishii, col. 3, lines 9-30; **“Signals received at different directional antennas 1-1 to 1-N are introduced into delay circuits 2-2 to 2-M. A directivity in a direction, for example, at every equal angle (360/N degrees) is assigned to each of antennas 1-1 to 1-N, respectively. Delay circuit 2-1 has a time delay of 0 and thus is omitted in the drawings. Delay circuits 2-2 to 2-M adaptively delay the received signals so that receivers 3-1 to 3-M may receive simultaneously the desired signal components incoming at different timings.”**).

Therefore, the combination of Crilly, Jr. and Ishii discloses receive a first signal transmission from a remote station via the antenna and a second signal transmission from *the* remote station.”

***Claim Rejections - 35 USC § 103***

4. The following is a quotation of pre-AIA 35 U.S.C. 103(a) which forms the basis for all obviousness rejections set forth in this Office action:

(a) A patent may not be obtained though the invention is not identically disclosed or described as set forth in section 102, if the differences between the subject matter sought to be patented and the prior art are such that the subject matter as a whole would have been obvious at the time the invention was made to a person having ordinary skill in the art to which said subject matter pertains. Patentability shall not be negated by the manner in which the invention was made.

5. The factual inquiries set forth in *Graham v. John Deere Co.*, 383 U.S. 1, 148 USPQ 459 (1966), that are applied for establishing a background for determining obviousness under pre-AIA 35 U.S.C. 103(a) are summarized as follows:

1. Determining the scope and contents of the prior art.
2. Ascertaining the differences between the prior art and the claims at issue.
3. Resolving the level of ordinary skill in the pertinent art.
4. Considering objective evidence present in the application indicating obviousness or nonobviousness.

6. Claims 1-20 is/are rejected under pre-AIA 35 U.S.C. 103(a) as being unpatentable over Crilly, Jr. et al. (US 2002/0158801 A1) in view of Ishii et al. (US 6,714,584).

**Regarding claim 1,**

As shown in FIGS. 1-24, Crilly discloses a receiver for use in a wireless communications system, the receiver comprising:

- an antenna (**see Crilly, FIG. 4, antenna array 110**);
- a transceiver operatively coupled to the antenna and configured to transmit and receive electromagnetic signals using the antenna (**see Crilly, FIG. 2, transmitter/receiver 114**); and
- a processor operatively coupled to the transceiver, (**see Crilly, FIG. 4, control logic 112**) the processor configured to:
  - receive a first signal transmission from a remote station via the antenna and a second signal transmission via the antenna (**see Crilly FIG. 4, paragraph [0091]; These signals, both desired and undesired, are collected by receiving elements within antenna array 110 and are eventually provided to control logic 110.**);
  - determine first signal information for the first signal transmission (**see Crilly, paragraph [0092]; Here, control logic 112 includes a search receiver 164 that is configured to update routing information 120 with regard to the received signals.**);
  - determine second signal information for the second signal transmission, wherein the second signal information is different than the first signal information (**see Crilly, paragraph [0092]; Here, control logic 112 includes**

**a search receiver 164 that is configured to update routing information 120 with regard to the received signals.);**

- determine a set of weighting values based on the first signal information and the second signal information, wherein the set of weighting values is configured to be used by the remote station to construct one or more beam-formed transmission signals (**see Crilly, paragraph [0093]; The stored weighting values associated with each connection/source are utilized in a weighting matrix 166. Weighting matrix 166 operates so as to apply the latest weighting values to the received signals and also to transmitted signals. In this illustrative example, subsequently received signals will be processed using the most recent weighting values in the weighting matrix.); and**
- cause the transceiver to generate a third signal comprising content based on the set of weighting values (**see Crilly, paragraph [0093]; The stored weighting values associated with each connection/source are utilized in a weighting matrix 166. Weighting matrix 166 operates so as to apply the latest weighting values to the received signals and also to transmitted signals. In this illustrative example, subsequently received signals will be processed using the most recent weighting values in the weighting matrix.)**

Crilly does not specifically disclose “receive a first signal transmission from a remote station via the antenna and a second signal transmission from the remote station via the antenna simultaneously.”

However, Ishii in the same field of endeavor discloses receiving a first signal transmission from a remote station via the antenna and a second signal transmission from the remote station via the antenna simultaneously (**see Ishii, col. 3, lines 9-30; “Signals received at different directional antennas 1-1 to 1-N are introduced into delay circuits 2-2 to 2-M. A directivity in a direction, for example, at every equal angle (360/N degrees) is assigned to each of antennas 1-1 to 1-N, respectively. Delay circuit 2-1 has a time delay of 0 and thus is omitted in the drawings. Delay circuits 2-2 to 2-M adaptively delay the received signals so that receivers 3-1 to 3-M may receive simultaneously the desired signal components incoming at different timings.”**).

It would have been obvious to one of ordinary skill in the art at the time the present invention was made to modify the invention of Crilly as taught by Ishii and receive a first signal transmission from a remote station via the antenna and a second signal transmission from the remote station via the antenna simultaneously.

***Rationale: Applying a known technique to a known device (method, or product) ready for improvement to yield predictable results***



To reject a claim based on this rationale, Office personnel must resolve the Graham factual inquiries. Then, Office personnel must articulate the following:

(1) a finding that the prior art contained a “base” device (method, or product) upon which the claimed invention can be seen as an “improvement;”

(2) a finding that the prior art contained a known technique that is applicable to the base device (method, or product);

(3) a finding that one of ordinary skill in the art would have recognized that applying the known technique would have yielded predictable results and resulted in an improved system; and

(4) whatever additional findings based on the Graham factual inquiries may be necessary, in view of the facts of the case under consideration, to explain a conclusion of obviousness. (MPEP § 2143).

In this case:

Crilly contains a “base” device of a receiver for use in a wireless communications system which the claimed invention can be seen as an “improvement” in that receiving a first signal transmission from a remote station via the antenna and a second signal transmission from the remote station via the antenna simultaneously.

Ishii contains known technique of a first signal transmission from a remote station via the antenna and a second signal transmission from the remote station via the antenna simultaneously that is applicable to the “base” device.

Ishii's known technique a first signal transmission from a remote station via the antenna and a second signal transmission from the remote station via the antenna simultaneously would have been recognized by one of ordinary skill in the art as applicable to the "base" process of Crilly and the results would have been predictable and resulted in a receiver for use in a wireless communications system receiving a first signal transmission from a remote station via the antenna and a second signal transmission from the remote station via the antenna simultaneously which results in an improved process.

Therefore, the claimed subject matter would have been obvious to a person having ordinary skill in the art at the time the invention was made.

**Regarding claim 2,**

The combination of Crilly and Ishii discloses the receiver as recited in Claim 1, wherein the antenna comprises a first antenna element and a second antenna element, and wherein the processor is further configured to:

receive the first signal transmission from the remote station via the first antenna element and the second signal transmission for the remote station via the second antenna element simultaneously (**see Crilly FIG. 4, paragraph [0091]; These signals, both desired and undesired, are collected by receiving elements within antenna array 110 and are eventually provided to control logic 110.**); and

cause the transceiver to transmit the third signal to the remote station via the antenna (**see Crilly, paragraph [0093]; Weighting matrix 166 operates so as to**

**apply the latest weighting values to the received signals and also to transmitted signals.)**

**Regarding claim 3,**

The combination of Crilly and Ishii discloses the receiver as recited in Claim 1, wherein the first signal transmission and the second signal transmission comprise electromagnetic signals comprising one or more transmission peaks and one or more transmission nulls (see Crilly, paragraph [0010]; **“The logic is operatively coupled to the antenna array and configured to selectively control the placement of the transmission peaks and transmission nulls within the outgoing multi-beam electromagnetic signals.”).**

**Regarding claim 4,**

The combination of Crilly and Ishii discloses the receiver as recited in Claim 1, wherein the first signal transmission and the second signal transmission are directional transmissions (see Crilly, paragraph [0009]; **In certain further implementations, the adaptive antenna is also configured to selectively receive at least one incoming electromagnetic signal directed through the coverage area.**).

**Regarding claim 5,**

The combination of Crilly and Ishii discloses the receiver as recited in Claim 1, wherein the set of weighting values is further based on one or more of: a transmit power level, a data transmit rate, an antenna direction, quality of service data, or timing data (see Crilly, paragraph [0011], “By way of example, the routing information may include transmit power level information, transmit data rate information, antenna pointing direction information, weighting information, constraints information, transmission null location information, transmission peak location information, Quality of Service (QoS) information, priority information, data packet lifetime information, frequency information, timing information, and/or keep out area information.”).

**Regarding claim 6,**

The combination of Crilly and Ishii discloses the receiver as recited in Claim 1, wherein the content comprises data configured to be used by the remote station to modify the placement of one or more transmission peaks and one or more transmission nulls in a subsequent signal transmission (see Crilly, paragraph [0057]; “...part of a wireless routing device and configured to produce a transmission pattern that selectively places transmission nulls and/or peaks in certain directions within an applicable coverage area.”)

**Regarding claim 7,**

The combination of Crilly and Ishii discloses the receiver as recited in Claim 1, wherein the processor is further configured to:

determine a plurality of signal strength indications for the first signal transmission; determine a first signal strength average based on the plurality of signal strength indications for the first signal transmission; determine a plurality of signal strength indications for the second signal transmission; determine a second signal strength average based on the plurality of signal strength indications for the second signal transmission (**see Crilly, paragraph [0012]; “All or part of this routing information may be stored in one or more routing tables. The routing table(s) may further include routing information such as, e.g., IP address information, MAC address information, protocol identifying information, modulation method identifying information, Connection ID (CID) information, node directional information, node transmit power level information, node received signal strength indicator (RSSI) level information, transmit channel information, backup transmit channel information, receive channel information, backup receive channel information, transmission data rate information, receive data rate information, and interference nulling information.”**); and

cause the transceiver to generate a fourth signal based on the first signal strength average and the second signal strength average (**see Crilly, paragraph [0016]; “The scheduler can establish one or more traffic schedules by determining at least one assignment for an outgoing data transmission.”**).

**Regarding claim 8,**

The combination of Crilly and Ishii discloses the receiver as recited in Claim 7, wherein the processor is further configured to: cause the transceiver to transmit the fourth signal to the remote station via the smart antenna (**see Crilly, paragraph [0016]; “The scheduler can establish one or more traffic schedules by determining at least one assignment for an outgoing data transmission.”**).

**Regarding claim 9,**

As shown in FIGS. 1-24, Crilly discloses a method in a wireless communications system, the method comprising:

- receiving a first signal transmission from a remote station via a first antenna element of an antenna and a second signal transmission via a second antenna element of the antenna (**see Crilly, FIG. 4, antenna array 110**);
- determining first signal information for the first signal transmission (**see Crilly FIG. 4, paragraph [0091]; These signals, both desired and undesired, are collected by receiving elements within antenna array 110 and are eventually provided to control logic 110.**);
- determining second signal information for the second signal transmission, wherein the second signal information is different than the first signal information (**see Crilly FIG. 4, paragraph [0091]; These signals, both desired and undesired, are collected by receiving elements within antenna array 110 and are eventually provided to control logic 110.**);

- determining a set of weighting values based on the first signal information and the second signal information, wherein the set of weighting values is configured to be used by the remote station to construct one or more beam-formed transmission signals (see Crilly, paragraph [0093]; The stored weighting values associated with each connection/source are utilized in a weighting matrix 166. Weighting matrix 166 operates so as to apply the latest weighting values to the received signals and also to transmitted signals. In this illustrative example, subsequently received signals will be processed using the most recent weighting values in the weighting matrix.); and
- transmitting to the remote station a third signal comprising content based on the set of weighting values (see Crilly, paragraph [0093]; The stored weighting values associated with each connection/source are utilized in a weighting matrix 166. Weighting matrix 166 operates so as to apply the latest weighting values to the received signals and also to transmitted signals. In this illustrative example, subsequently received signals will be processed using the most recent weighting values in the weighting matrix.).

Crilly does not specifically disclose “receive a first signal transmission from a remote station via the antenna and a second signal transmission from the remote station via the antenna simultaneously.”

However, Ishii in the same field of endeavor discloses receiving a first signal transmission from a remote station via the antenna and a second signal transmission

from the remote station via the antenna simultaneously (see Ishii, col. 3, lines 9-30; “Signals received at different directional antennas 1-1 to 1-N are introduced into delay circuits 2-2 to 2-M. A directivity in a direction, for example, at every equal angle ( $360/N$  degrees) is assigned to each of antennas 1-1 to 1-N, respectively. Delay circuit 2-1 has a time delay of 0 and thus is omitted in the drawings. Delay circuits 2-2 to 2-M adaptively delay the received signals so that receivers 3-1 to 3-M may receive simultaneously the desired signal components incoming at different timings.”).

It would have been obvious to one of ordinary skill in the art at the time the present invention was made to modify the invention of Crilly as taught by Ishii and receive a first signal transmission from a remote station via the antenna and a second signal transmission from the remote station via the antenna simultaneously.

***Rationale: Applying a known technique to a known device (method, or product) ready for improvement to yield predictable results***

To reject a claim based on this rationale, Office personnel must resolve the Graham factual inquiries. Then, Office personnel must articulate the following:

- (1) a finding that the prior art contained a “base” device (method, or product) upon which the claimed invention can be seen as an “improvement;”
- (2) a finding that the prior art contained a known technique that is applicable to the base device (method, or product);



(3) a finding that one of ordinary skill in the art would have recognized that applying the known technique would have yielded predictable results and resulted in an improved system; and

(4) whatever additional findings based on the Graham factual inquiries may be necessary, in view of the facts of the case under consideration, to explain a conclusion of obviousness. (MPEP § 2143).

In this case:

Crilly contains a "base" device of a receiver for use in a wireless communications system which the claimed invention can be seen as an "improvement" in that receiving a first signal transmission from a remote station via the antenna and a second signal transmission from the remote station via the antenna simultaneously.

Ishii contains known technique of a first signal transmission from a remote station via the antenna and a second signal transmission from the remote station via the antenna simultaneously that is applicable to the "base" device.

Ishii's known technique a first signal transmission from a remote station via the antenna and a second signal transmission from the remote station via the antenna simultaneously would have been recognized by one of ordinary skill in the art as applicable to the "base" process of Crilly and the results would have been predictable and resulted in a receiver for use in a wireless communications system receiving a first signal transmission from a remote station via the antenna and a second signal

transmission from the remote station via the antenna simultaneously which results in an improved process.

Therefore, the claimed subject matter would have been obvious to a person having ordinary skill in the art at the time the invention was made.

**Regarding claim 10,**

The combination of Crilly and Ishii discloses the method as recited in Claim 9, further comprising: transmitting the third signal to the remote station via the antenna **(see Crilly, paragraph [0016]; “The scheduler can establish one or more traffic schedules by determining at least one assignment for an outgoing data transmission.”)**.

**Regarding claim 11,**

The combination of Crilly and Ishii discloses the method as recited in Claim 9, wherein the first signal transmission and the second signal transmission comprise electromagnetic signals comprising one or more transmission peaks and one or more transmission nulls **(see Crilly, paragraph [0010]; “The logic is operatively coupled to the antenna array and configured to selectively control the placement of the transmission peaks and transmission nulls within the outgoing multi-beam electromagnetic signals.”)**.

**Regarding claim 12,**

The combination of Crilly and Ishii discloses the method as recited in Claim 9, wherein the first signal transmission and the second signal transmission are directional transmissions (**see Crilly, paragraph [0009]; In certain further implementations, the adaptive antenna is also configured to selectively receive at least one incoming electromagnetic signal directed through the coverage area.**).

**Regarding claim 13,**

The combination of Crilly and Ishii discloses the method as recited in Claim 9, wherein the set of weighting values is further based on one or more of: a transmit power level, a data transmit rate, an antenna direction, quality of service data, or timing data (**see Crilly, paragraph [0011], “By way of example, the routing information may include transmit power level information, transmit data rate information, antenna pointing direction information, weighting information, constraints information, transmission null location information, transmission peak location information, Quality of Service (QoS) information, priority information, data packet lifetime information, frequency information, timing information, and/or keep out area information.”**).

**Regarding claim 14,**

The combination of Crilly and Ishii discloses the method as recited in Claim 9, wherein the one or more beam-formed transmission signals comprise data configured to be used by the remote station to modify the placement of one or more transmission

peaks and one or more transmission nulls in a subsequent signal transmission (see **Crilly, paragraph [0010]**; **“The logic is operatively coupled to the antenna array and configured to selectively control the placement of the transmission peaks and transmission nulls within the outgoing multi-beam electromagnetic signals.”).**

**Regarding claim 15,**

The combination of Crilly and Ishii discloses the method as recited in Claim 9, wherein the processor is further configured to: determining a plurality of signal strength indications for the first signal transmission; determining a first signal strength average based on the plurality of signal strength indications for the first signal transmission; determining a plurality of signal strength indications for the second signal transmission ; determining a second signal strength average based on the plurality of signal strength indications for the second signal transmission; and determining a set of weighting values based on the first signal information and the second signal information, wherein the set of weighting values is configured to construct one or more beam-formed transmission signals (see **Crilly, paragraph [0012]**; **“All or part of this routing information may be stored in one or more routing tables. The routing table(s) may further include routing information such as, e.g., IP address information, MAC address information, protocol identifying information, modulation method identifying information, Connection ID (CID) information, node directional information, node transmit power level information, node received signal strength**

**indicator (RSSI) level information, transmit channel information, backup transmit channel information, receive channel information, backup receive channel information, transmission data rate information, receive data rate information, and interference nulling information.**”); and

generating the one or more beam-formed transmission signals based on the set of weighting values for transmission to the remote station (**see Crilly, paragraph [0016]; “The scheduler can establish one or more traffic schedules by determining at least one assignment for an outgoing data transmission.”**).

**Regarding claim 16,**

The combination of Crilly and Ishii discloses the method as recited in Claim 15, further comprising: causing the transceiver to transmit the fourth signal to the remote station via the antenna (**see Crilly, paragraph [0016]; “The scheduler can establish one or more traffic schedules by determining at least one assignment for an outgoing data transmission.”**).

**Regarding claim 17,**

As shown in FIGS. 1-24, Crilly discloses an apparatus for use in a wireless communications system, the apparatus comprising:

- an antenna (**see Crilly, FIG. 4, antenna array 110**);
- a transceiver operatively coupled to the antenna (**see Crilly, FIG. 2, transmitter/receiver 114**); and

- a processor operatively coupled to the transceiver (**see Crilly, FIG. 4, control logic 112**), the processor configured to:
  - receive a first signal transmission from a remote station via the antenna, the first signal transmission comprising first signal information (**see Crilly FIG. 4, paragraph [0091]; These signals, both desired and undesired, are collected by receiving elements within antenna array 110 and are eventually provided to control logic 110.**);
  - receive a second signal transmission via the antenna, the second signal transmission comprising second signal information (**see Crilly FIG. 4, paragraph [0091]; These signals, both desired and undesired, are collected by receiving elements within antenna array 110 and are eventually provided to control logic 110.**);
  - determine a set of weighting values based on the first signal information and the second signal information, wherein the set of weighting values is configured to be used by the remote station to construct one or more beam-formed transmission signals (**see Crilly, paragraph [0093]; The stored weighting values associated with each connection/source are utilized in a weighting matrix 166. Weighting matrix 166 operates so as to apply the latest weighting values to the received signals and also to transmitted signals. In this illustrative example, subsequently received signals will be processed using the most recent weighting values in the weighting matrix.**);

- cause the transceiver to generate a third signal comprising content based on the set of weighting values (see Crilly, paragraph [0093]; **The stored weighting values associated with each connection/source are utilized in a weighting matrix 166. Weighting matrix 166 operates so as to apply the latest weighting values to the received signals and also to transmitted signals. In this illustrative example, subsequently received signals will be processed using the most recent weighting values in the weighting matrix.**).

Crilly does not specifically disclose “receive a first signal transmission from a remote station via the antenna and a second signal transmission from the remote station via the antenna.”

However, Ishii in the same field of endeavor discloses receiving a first signal transmission from a remote station via the antenna and a second signal transmission from the remote station via the antenna (see Ishii, col. 3, lines 9-30; “**Signals received at different directional antennas 1-1 to 1-N are introduced into delay circuits 2-2 to 2-M. A directivity in a direction, for example, at every equal angle (360/N degrees) is assigned to each of antennas 1-1 to 1-N, respectively. Delay circuit 2-1 has a time delay of 0 and thus is omitted in the drawings. Delay circuits 2-2 to 2-M adaptively delay the received signals so that receivers 3-1 to 3-M may receive simultaneously the desired signal components incoming at different timings.**”).

It would have been obvious to one of ordinary skill in the art at the time the present invention was made to modify the invention of Crilly as taught by Ishii and receive a first signal transmission from a remote station via the antenna and a second signal transmission from the remote station via the antenna.

***Rationale: Applying a known technique to a known device (method, or product) ready for improvement to yield predictable results***

To reject a claim based on this rationale, Office personnel must resolve the Graham factual inquiries. Then, Office personnel must articulate the following:

- (1) a finding that the prior art contained a “base” device (method, or product) upon which the claimed invention can be seen as an “improvement;”
- (2) a finding that the prior art contained a known technique that is applicable to the base device (method, or product);
- (3) a finding that one of ordinary skill in the art would have recognized that applying the known technique would have yielded predictable results and resulted in an improved system; and
- (4) whatever additional findings based on the Graham factual inquiries may be necessary, in view of the facts of the case under consideration, to explain a conclusion of obviousness. (MPEP § 2143).

In this case:



Crilly contains a "base" device of a receiver for use in a wireless communications system which the claimed invention can be seen as an "improvement" in that receiving a first signal transmission from a remote station via the antenna and a second signal transmission from the remote station via the antenna simultaneously.

Ishii contains known technique of a first signal transmission from a remote station via the antenna and a second signal transmission from the remote station via the antenna simultaneously that is applicable to the "base" device.

Ishii's known technique a first signal transmission from a remote station via the antenna and a second signal transmission from the remote station via the antenna simultaneously would have been recognized by one of ordinary skill in the art as applicable to the "base" process of Crilly and the results would have been predictable and resulted in a receiver for use in a wireless communications system receiving a first signal transmission from a remote station via the antenna and a second signal transmission from the remote station via the antenna simultaneously which results in an improved process.

Therefore, the claimed subject matter would have been obvious to a person having ordinary skill in the art at the time the invention was made.

**Regarding claim 18,**

The combination of Crilly and Ishii discloses the apparatus as recited in Claim 17, wherein the first signal transmission and the second signal transmission comprise electromagnetic signals comprising one or more transmission peaks and one or more

transmission nulls (**see Crilly, paragraph [0010]; “The logic is operatively coupled to the antenna array and configured to selectively control the placement of the transmission peaks and transmission nulls within the outgoing multi-beam electromagnetic signals.”).**

**Regarding claim 19,**

The combination of Crilly and Ishii discloses the apparatus as recited in Claim 17, wherein the first signal information comprises one or more of: a transmit power level, a data transmit rate, an antenna direction, quality of service data, or timing data (**see Crilly, paragraph [0011], “By way of example, the routing information may include transmit power level information, transmit data rate information, antenna pointing direction information, weighting information, constraints information, transmission null location information, transmission peak location information, Quality of Service (QoS) information, priority information, data packet lifetime information, frequency information, timing information, and/or keep out area information.”**).

**Regarding claim 20,**

The combination of Crilly and Ishii discloses the apparatus as recited in Claim 17, wherein the antenna comprises a first antenna element and a second antenna element, and wherein the first antenna element and the second antenna element are directional antenna elements (**see Crilly, paragraph [0009]; In certain further implementations,**

**the adaptive antenna is also configured to selectively receive at least one incoming electromagnetic signal directed through the coverage area.)).**

### ***Conclusion***

7. **THIS ACTION IS MADE FINAL.** Applicant is reminded of the extension of time policy as set forth in 37 CFR 1.136(a).

A shortened statutory period for reply to this final action is set to expire THREE MONTHS from the mailing date of this action. In the event a first reply is filed within TWO MONTHS of the mailing date of this final action and the advisory action is not mailed until after the end of the THREE-MONTH shortened statutory period, then the shortened statutory period will expire on the date the advisory action is mailed, and any extension fee pursuant to 37 CFR 1.136(a) will be calculated from the mailing date of the advisory action. In no event, however, will the statutory period for reply expire later than SIX MONTHS from the mailing date of this final action.

Any inquiry concerning this communication or earlier communications from the examiner should be directed to GINA MCKIE whose telephone number is (571)270-5148. The examiner can normally be reached on Mon-Fri, 8:30 AM-5:00 PM EST.

Examiner interviews are available via telephone, in-person, and video conferencing using a USPTO supplied web-based collaboration tool. To schedule an interview, applicant is encouraged to use the USPTO Automated Interview Request (AIR) at <http://www.uspto.gov/interviewpractice>.

If attempts to reach the examiner by telephone are unsuccessful, the examiner's supervisor, Shuwang Liu can be reached on 571-272-3036. The fax phone number for the organization where this application or proceeding is assigned is 571-273-8300.

Information regarding the status of an application may be obtained from the Patent Application Information Retrieval (PAIR) system. Status information for published applications may be obtained from either Private PAIR or Public PAIR. Status information for unpublished applications is available through Private PAIR only. For more information about the PAIR system, see <http://pair-direct.uspto.gov>. Should you have questions on access to the Private PAIR system, contact the Electronic Business Center (EBC) at 866-217-9197 (toll-free). If you would like assistance from a USPTO Customer Service Representative or access to the automated information system, call 800-786-9199 (IN USA OR CANADA) or 571-272-1000.

/GINA MCKIE/  
Examiner, Art Unit 2631

/SHUWANG LIU/  
Supervisory Patent Examiner, Art Unit 2631

<b>Notice of References Cited</b>	Application/Control No. 15/495,539	Applicant(s)/Patent Under Reexamination DA SILVA ET AL.	
	Examiner GINA MCKIE	Art Unit 2631	Page 1 of 1

**U.S. PATENT DOCUMENTS**

*		Document Number Country Code-Number-Kind Code	Date MM-YYYY	Name	CPC Classification	US Classification
*	A	US-5,809,422 A	09-1998	Raleigh; Gregory G.	H04B7/2609	455/444
	B	US-				
	C	US-				
	D	US-				
	E	US-				
	F	US-				
	G	US-				
	H	US-				
	I	US-				
	J	US-				
	K	US-				
	L	US-				
	M	US-				

**FOREIGN PATENT DOCUMENTS**

*		Document Number Country Code-Number-Kind Code	Date MM-YYYY	Country	Name	CPC Classification
	N					
	O					
	P					
	Q					
	R					
	S					
	T					

**NON-PATENT DOCUMENTS**

*		Include as applicable: Author, Title Date, Publisher, Edition or Volume, Pertinent Pages)
	U	
	V	
	W	
	X	

\*A copy of this reference is not being furnished with this Office action. (See MPEP § 707.05(a).)  
Dates in MM-YYYY format are publication dates. Classifications may be US or foreign.

PTO/SB/08 Equivalent

<b>INFORMATION DISCLOSURE STATEMENT BY APPLICANT</b>	Application No.	15/495,539	
	Filing Date	April 24, 2017	
	First Named Inventor	Marcus Da Silva	
	Art Unit	2631	
<i>(Multiple sheets used when necessary)</i>		Examiner	McKie, Gina M.
SHEET 1 OF 8		Attorney Docket No.	1640-001.203

U.S. PATENT DOCUMENTS					
Examiner Initials	Cite No.	Document Number <i>Number - Kind Code (if known)</i> Example: 1,234,567 B1	Publication Date MM-DD-YYYY	Name of Patentee or Applicant	Pages, Columns, Lines Where Relevant Passages or Relevant Figures Appear
	1	4,750,147	06-07-1998	Roy, III et al.	
	2	4,965,732	10-23-1990	Roy, III et al.	
	3	5,095,531	03-10-1992	Ito	
	4	5,345,599 A	09-06-1994	Paulraj et al.	
	5	5,471,647	11-28-1995	Gerlach et al.	
	6	5,515,378 A	05-07-1996	Roy, III et al.	
	7	5,546,090	08-13-1996	Roy, III et al.	
	8	5,553,074	09-03-1996	Acampora	
	9	5,592,490	01-07-1997	Barratt et al.	
	10	5,602,555	02-11-1997	Searle et al.	
	11	5,603,089	02-11-1997	Searle et al.	
	12	5,634,199	05-27-1997	Gerlach et al.	
	13	5,642,353 A	06-24-1997	Roy, III et al.	
	14	5,649,293	07-15-1997	Reed	
	15	5,687,194 A	11-11-1997	Paneth et al.	
	16	5,697,066	12-09-1997	Acampora	
	17	5,739,788	04-14-1998	Dybdal et al.	
	18	5,828,658 A	10-27-1998	Ottersten et al.	
	19	5,886,988	03-23-1999	Yun et al.	
	20	5,890,067	03-30-1999	Chang et al.	
	21	5,914,946 A	06-22-1999	Avidor et al.	
	22	5,966,094	10-12-1999	Ward et al.	
	23	6,006,110	12-21-1999	Raleigh	
	24	6,067,290	05-23-2000	Paulraj et al.	
	25	6,101,399	08-08-2000	Raleigh et al.	
	26	6,219,561	04-17-2001	Raleigh	
	27	6,233,466	05-15-2001	Wong et al.	
	28	6,330,460	12-11-2001	Wong et al.	
	29	6,345,188	02-05-2002	Keskitalo et al.	

Examiner Signature /GINA M MCKIE/	Date Considered 01/18/2018
<p>*Examiner: Initial if reference considered, whether or not citation is in conformance with MPEP 609. Draw line through citation if not in conformance and not considered. Include copy of this form with next communication to applicant.</p>	

T<sup>1</sup> - Place a check mark in this area when an English language Translation is attached.

ALL REFERENCES CONSIDERED EXCEPT WHERE LINED THROUGH. /G.M.M/

PTO/SB/08 Equivalent

<b>INFORMATION DISCLOSURE STATEMENT BY APPLICANT</b>	Application No.	15/495,539	
	Filing Date	April 24, 2017	
	First Named Inventor	Marcus Da Silva	
	Art Unit	2631	
<i>(Multiple sheets used when necessary)</i>		Examiner	McKie, Gina M.
SHEET 2 OF 8		Attorney Docket No.	1640-001.203

U.S. PATENT DOCUMENTS					
Examiner Initials	Cite No.	Document Number <i>Number - Kind Code (if known)</i> Example: 1,234,567 B1	Publication Date MM-DD-YYYY	Name of Patentee or Applicant	Pages, Columns, Lines Where Relevant Passages or Relevant Figures Appear
	30	6,351,499	02-26-2002	Paulraj et al.	
	31	6,438,376	08-20-2002	Elliott et al.	
	32	6,564,036	05-13-2003	Kasapi	
	33	6,611,695	08-26-2003	Periyalwar	
	34	6,665,545 B1	12-16-2003	Raleigh et al.	
	35	6,667,712	12-23-2003	Ericson et al.	
	36	6,687,492	02-03-2004	Sugar et al.	
	37	6,694,154	02-17-2004	Molnar et al.	
	38	6,748,216	06-08-2004	Lee	
	39	6,795,409	09-21-2004	Youssefmir et al.	
	40	6,823,174	11-23-2004	Masenten et al.	
	41	6,850,741	02-01-2005	Lei et al.	
	42	6,853,333	02-08-2005	Ericson et al.	
	43	7,020,110	03-28-2006	Walton et al.	
	44	7,031,336	04-18-2006	Scherzer et al.	
	45	7,054,662	05-30-2006	Judson	
	46	7,062,294	06-13-2006	Rogard et al.	
	47	7,133,380	11-07-2006	Winters et al.	
	48	7,289,826	10-30-2007	Hovers et al.	
	49	7,346,365	03-18-2008	Hovers et al.	
	50	7,492,743	02-17-2009	Uhlik	
	51	7,529,305	05-05-2009	Tong et al.	
	52	2001/0033600	10-25-2001	Yang et al.	
	53	2002/0034967	03-21-2002	Taniguchi et al.	
	54	2003/0017853	01-23-2003	Kanamaluru et al.	

FOREIGN PATENT DOCUMENTS						
Examiner Initials	Cite No.	Foreign Patent Document <i>Country Code-Number-Kind Code</i> Example: JP 1234567 A1	Publication Date MM-DD-YYYY	Name of Patentee or Applicant	Pages, Columns, Lines Where Relevant Passages or Relevant Figures Appear	T <sup>1</sup>

Examiner Signature /GINA M MCKIE/ Date Considered 01/18/2018

\*Examiner: Initial if reference considered, whether or not citation is in conformance with MPEP 609. Draw line through citation if not in conformance and not considered. Include copy of this form with next communication to applicant.

T<sup>1</sup> - Place a check mark in this area when an English language Translation is attached.  
**ALL REFERENCES CONSIDERED EXCEPT WHERE LINED THROUGH. /G.M.M/**

PTO/SB/08 Equivalent

<b>INFORMATION DISCLOSURE STATEMENT BY APPLICANT</b>	Application No.	15/495,539	
	Filing Date	April 24, 2017	
	First Named Inventor	Marcus Da Silva	
	Art Unit	2631	
<i>(Multiple sheets used when necessary)</i>		Examiner	McKie, Gina M.
SHEET 3 OF 8		Attorney Docket No.	1640-001.203

FOREIGN PATENT DOCUMENTS						
Examiner Initials	Cite No.	Foreign Patent Document Country Code-Number-Kind Code Example: JP 1234567 A1	Publication Date MM-DD-YYYY	Name of Patentee or Applicant	Pages, Columns, Lines Where Relevant Passages or Relevant Figures Appear	T <sup>1</sup>
	55	WO 00/38455 A1	06-29-2000	Telefonaktiebolaget LM Ericsson		
	56	WO 00/72464 A1	11-30-2000	Nokia Networks		
	57	WO 01/10156 A1	02-08-2001	Gigabit Wireless, Inc.		
	58	WO 01/010156 A1	02-08-2001	Iospan Wireless, Inc.		
	59	WO 03/075396 A2	09-12-2003	Cognio, Inc.		
	60	WO 96/21117	07-11-1996	Automotive Products France S.A.		
	61	WO 97/00543 A1	01-03-1997	Watkins-Johnson Company		
	62	WO 97/33388 A1	09-12-1997	Watkins-Johnson Company		
	63	WO 98/09381 A1	03-05-1998	The Board of Trustees of the Leland Stanford Junior University		
	64	WO 98/18271 A3	04-30-1998	Watkins Johnson Company		
	65	WO 99/21391 A2	04-29-1999	Radio Design Innovation TJ AB		
	66	EP 0817517 A1	01-07-1998	NTT Mobile Communications Network Inc.		

NON PATENT LITERATURE DOCUMENTS			
Examiner Initials	Cite No.	Include name of the author (in CAPITAL LETTERS), title of the article (when appropriate), title of the item (book, magazine, journal, serial, symposium, catalog, etc.), date, page(s), volume-issue number(s), publisher, city and/or country where published.	T <sup>1</sup>
	67	"Part 11: Wireless LAN Medium Access Control (MAC) and Physical Layer (PHY) specifications: Higher-Speed Physical Layer Extension in the 2.4 GHz Band", Supplement to IEEE Standard for Information technology - Telecommunications and information exchange between systems - Local and metropolitan area networks - Specific requirements. IEEE Std 802.11b-1999(R2003); Sponsor LAN/MAN Standards Committee of the IEEE Computer Society; Reaffirmed 12 June 2003, Approved 16 September 1999, IEEE-SA Standards Board. (0001)	
	68	MARTIN COOPER, "A Layman's Guide to Cellular, Annual Review of Communications", 1996, pages 993-997. (0097; 2478)	
	69	ANDERSON et al., "An Adaptive Array for Mobile Communication Systems", IEEE Transactions On Vehicular Technology, Vol. 40, No. 1, February 1991, pages 230-236. (0102; 2415)	
	<del>70</del>	<del>RICHARD H. ROY, "Application of Smart Antenna Technology in Wireless Communication Systems", pages 1-6. (0109; 0115; 3059)</del>	
	<del>71</del>	<del>BJORN OTTERSTEN, "Array Processing for Wireless Communications", 8th IEEE Signal Processing Workshop on Statistical Signal and Array Processing. (0121; 2974)</del>	
	72	G. J. FOSCHINI et al., "BLAST: Bell Labs Layered Space-Time, An Architecture for Realizing Very High Data Rates Over Fading Wireless Channels", <a href="https://web.archive.org/web/19990221074508/https://www.bell-labs.com/pr">https://web.archive.org/web/19990221074508/https://www.bell-labs.com/pr</a> , Lucent Technologies, 1998, 3 pages. (0130; 2528)	

Examiner Signature	/GINA M MCKIE/	Date Considered	01/18/2018
<p>*Examiner: Initial if reference considered, whether or not citation is in conformance with MPEP 609. Draw line through citation if not in conformance and not considered. Include copy of this form with next communication to applicant.</p>			

T<sup>1</sup> - Place a check mark in this area when an English language Translation is attached.

ALL REFERENCES CONSIDERED EXCEPT WHERE LINED THROUGH. /G.M.M/



PTO/SB/08 Equivalent

<b>INFORMATION DISCLOSURE STATEMENT BY APPLICANT</b>	Application No.	15/495,539
	Filing Date	April 24, 2017
	First Named Inventor	Marcus Da Silva
	Art Unit	2631
<i>(Multiple sheets used when necessary)</i>		Examiner McKie, Gina M.
SHEET 4 OF 8		Attorney Docket No. 1640-001.203

NON PATENT LITERATURE DOCUMENTS			
Examiner Initials	Cite No.	Include name of the author (in CAPITAL LETTERS), title of the article (when appropriate), title of the item (book, magazine, journal, serial, symposium, catalog, etc.), date, page(s), volume-issue number(s), publisher, city and/or country where published.	T <sup>1</sup>
	73	BRANDENBURG, L. H. et al., "Capacity of the Gaussian Channel With Memory: The Multivariate Case", The Bell System Technical Journal, Vol. 63, No. 5, May-June 1974, pages 745-764. (0133; 2436)	
	74	Dean CHAPMAN, "First-Hand: Sidelobe Cancellers and the Like", <a href="http://ethw.org/First-Hand:Sidelobe_Cancellers_and_the_Like">http://ethw.org/First-Hand:Sidelobe_Cancellers_and_the_Like</a> , April 12, 2017, 4 pages. (0167; 2474)	
	75	LI, HANG et al., "Coded Beamforming for Block Fading Vector Channel", 2001 IEEE, pages 1137-1141. (0171; 2949)	
	76	DANDEKAR, K.R. et al., "Effect of mutual coupling on direction finding in smart antenna applications", Electronics Letters, Vol. 36, No. 22, October 26, 2000, pages 1889-1891. (0176; 2487)	
	77	L. BIGLER, H.P. et al., "Experimental Direction of Arrival and Spatial Signature Measurements at 900 MHz for Smart Antenna Systems", 1995 IEEE, pages 55-58. (0179; 2432)	
	78	JENG, SHIANN-SHIUN et al., "Experimental Evaluation of Smart Antenna System Performance for Capacity Improvement", 1997 IEEE, pages 369-373. (0183; 2897)	
	79	JENG, SHIANN-SHIUN et al., "Experimental Evaluation of Smart Antenna System Performance for Wireless Communications", IEEE Transactions on Antennas and Propagation, Vol. 46, No. 6, June 1998, pages 749-757. (0188; 2902)	
	80	XU, G. et al., "Experimental Studies of Space-Division-Multiple-Access Schemes for Spectral Efficient Wireless Communications", 1994 IEEE, pages 800-804. (0197; 988)	
	81	JENG, SHIANN-SHIUN et al., "Experimental Studies of Spatial Signature Variation at 900 MHz for Smart Antenna Systems", IEEE Transactions on Antennas and Propagation, Vol. 46, No. 7, July 1998, pages 953-962. (0202; 2911)	
	82	FENN, ALAN J. et al., "The Development of Phased-Array Radar Technology", Lincoln Laboratory Journal, Vol. 12, No. 2, 2000, pages 321-340. (0212; 2508)	
	83	FOSCHINI, GERARD J., "Layered Space-Time Architecture for Wireless Communication in a Fading Environment When Using Multi-Element Antennas", Bell Labs Technical Journal, Autumn 1996, pages 41-59. (0232; 2531)	
	84	"Part 11: Wireless LAN Medium Access Control (MAC) and Physical Layer (PHY) specifications High-speed Physical Layer in the 5 GHz Band", Supplement to IEEE Standard for Information technology - Telecommunications and information exchange between systems - Local and metropolitan area networks - Specific requirements. IEEE Std 802.11a-1999(R2003); Sponsor LAN/MAN Standards Committee of the IEEE Computer Society; Reaffirmed 12 June 2003, IEEE-SA Standards Board. (0251)	
	85	COOPER, Martin, et al., "Intelligent Antennas: Spatial Division Multiple Access", Annual Review of Communications, 1996, pages 999-1002. (0342; 2483)	
	86	KAYE, A. ROGER, et al., "Transmission of Multiplexed PAM Signals Over Multiple Channel and Diversity Systems", IEEE Transactions on Communication Technology, Vol. Com-18, No. 5, October 1970, pages 520-526. (0346; 2934)	
	87	KANG, JOONHYUK, et al., "Low Complexity Array Response Vector Estimation For Smart Antenna Systems, 2000 IEEE, pages 841-845. (0353; 2921)	
	88	DANDEKAR, KAPIL R., et al., "Modeling and Prediction of the Wireless Vector Channel Encountered by Smart Antenna Systems", Microwave and Optical Technology Letters, Vol. 35, No. 4, November 20, 2002, pages 281-283. (0358; 2490)	

Examiner Signature /GINA M MCKIE/	Date Considered 01/18/2018
*Examiner: Initial if reference considered, whether or not citation is in conformance with MPEP 609. Draw line through citation if not in conformance and not considered. Include copy of this form with next communication to applicant.	

T<sup>1</sup> - Place a check mark in this area when an English language Translation is attached.

ALL REFERENCES CONSIDERED EXCEPT WHERE LINED THROUGH. /G.M.M/

PTO/SB/08 Equivalent

<b>INFORMATION DISCLOSURE STATEMENT BY APPLICANT</b>	Application No.	15/495,539	
	Filing Date	April 24, 2017	
	First Named Inventor	Marcus Da Silva	
	Art Unit	2631	
<i>(Multiple sheets used when necessary)</i>		Examiner	McKie, Gina M.
SHEET 5 OF 8		Attorney Docket No.	1640-001.203

**NON PATENT LITERATURE DOCUMENTS**

Examiner Initials	Cite No.	Include name of the author (in CAPITAL LETTERS), title of the article (when appropriate), title of the item (book, magazine, journal, serial, symposium, catalog, etc.), date, page(s), volume-issue number(s), publisher, city and/or country where published.	T <sup>1</sup>
	89	SWALES, S.C., et al., "Multi-Beam Adaptive Base-Station Antennas For Cellular Land Mobile Radio Systems", 1989 IEEE 39 <sup>th</sup> Vehicular Technology Conference, San Francisco, Vol. 1, pages 341-348. (0361; 0475; 3108)	
	<del>90</del>	<del>YANG, WEIDONG, et al., "New Method for Designing Smart Antenna Downlink Weighting Vectors Based on the Filter Bank Concept", SPIE Vol. 3162, pages 240-250. (0369; 3664)</del>	
	91	BALABAN, PHILIP, et al., "Optimum Diversity Combining and Equalization In Digital Data Transmission with Applications to Cellular Mobile Radio - Part 1: Theoretical Considerations", IEEE Transactions on Communications, Vol. 40, No. 5, May 1992, pages 885-894. (0380; 2422)	
	92	NAGUIB, AYMAN F., et al., "Performance of CDMA Cellular Networks With Base-Station Antenna Arrays: The Downlink", 1994 IEEE, pages 795-799. (0390; 2959)	
	<del>93</del>	<del>RALEIGH, GREGORY, et al., "Characterization of Fast Fading Vector Channels for Multi-Antenna Communication Systems". (0395; 3032)</del>	
	<del>94</del>	<del>RALEIGH, GREGORY G., et al., "Spatia-Temporal Coding for Wireless Communication". IEEE Transactions on Communications, Vol. 46, No. 3, March 1998, pages 357-366. (0400; 3037)</del>	
	95	CADZOW, J.A., et al., "Resolution of Coherent Signals Using A Linear Array", 1987 IEEE, pages 1597-1600. (0410; 2470)	
	96	REUDINK, D.O., et al., "A Scanning Spot-Beam Satellite System", The Bell System Technical Journal, Vol. 56, No. 8, October 1997, pages 1549-1560. (0414; 3047)	
	97	NOWICKI, DAVID, et al., "Smart Antenna Strategies", Mobile Communications Int'l, April 1995, pages 1-10. (0426; 2964)	
	98	XU, GUANGHAN, et al., "Smart Antenna Systems for Wireless Communications", 1998 IEEE, pages 631-634. (0436; 3657)	
	99	PAULRAJ, AROGYASWAMI J., et al., "Space-Time Processing for Wireless Communications", IEEE Signal Processing Magazine, November 1997, pages 49-83. (0440; 2983)	
	100	WINTERS, JACK H., et al., "The Impact of Antenna Diversity on the Capacity of Wireless Communication Systems", IEEE Transactions on Communications, Vol. 42, No. 2/3/4, Feb/March/April 1994, pages 1740-1751. (0484; 3619)	
	101	GOLDBURG, MARK, et al., "The Impacts of SDMA on PCS System Design", IEEE, 1994, Session 1.10, ArrayComm, Inc., Santa Clara, CA, pages 242-246. (0496; 2705)	
	102	LI, HANG, et al., "Transmission Optimization Over Flat Rayleigh Fading Channel with Multiple Antennas", 1999 IEEE, pages 210-214. (0501; 2954)	
	103	VAN ET TEN W., "Maximum Likelihood Receiver for Multiple Channel Transmission Systems", IEEE Transactions on Communications, February 1976, pages 276-283. (0767; 3599)	
	104	KAVAK, ADNAN, et al., "Vector Channels for Smart Antennas-Measurements, Statistical Modeling, and Directional Properties in Outdoor Environments", IEEE Transactions on Microwave Theory and Techniques, Vol. 48, No. 6, June 2000, pages 930-937. (0775; 2926)	
	<del>105</del>	<del>Antennas and Antenna Systems, Smart Antenna Systems Tutorial, <a href="http://www.iec.org:80/tutorials/smart_ant/topic02.html">http://www.iec.org:80/tutorials/smart_ant/topic02.html</a>. (0783)</del>	
	<del>106</del>	<del>Correct Answers, Smart Antenna Systems Tutorial, <a href="http://www.iec.org:80/tutorials/smart_ant/answers.html">http://www.iec.org:80/tutorials/smart_ant/answers.html</a>. (0788)</del>	

Examiner Signature /GINA M MCKIE/	Date Considered 01/18/2018
*Examiner: Initial if reference considered, whether or not citation is in conformance with MPEP 609. Draw line through citation if not in conformance and not considered. Include copy of this form with next communication to applicant.	

T<sup>1</sup> - Place a check mark in this area when an English language Translation is attached.

ALL REFERENCES CONSIDERED EXCEPT WHERE LINED THROUGH. /G.M.M/

PTO/SB/08 Equivalent

<b>INFORMATION DISCLOSURE STATEMENT BY APPLICANT</b>	Application No.	15/495,539
	Filing Date	April 24, 2017
	First Named Inventor	Marcus Da Silva
	Art Unit	2631
<i>(Multiple sheets used when necessary)</i>	Examiner	McKie, Gina M.
SHEET 6 OF 8	Attorney Docket No.	1640-001.203

**NON PATENT LITERATURE DOCUMENTS**

Examiner Initials	Cite No.	Include name of the author (in CAPITAL LETTERS), title of the article (when appropriate), title of the item (book, magazine, journal, serial, symposium, catalog, etc.), date, page(s), volume-issue number(s), publisher, city and/or country where published.	T <sup>1</sup>
	107	Signal Propagation: Multipath And Cochannel Interference, Smart Antenna Systems Tutorial. (0791; 0800)	
	108	What Is a Smart Antenna System?, Smart Antenna Systems Tutorial, <a href="http://www.iec.org:80/tutorials/smart_ant/topic03.html">http://www.iec.org:80/tutorials/smart_ant/topic03.html</a> . (0796)	
	109	Who Can Use Smart Antenna Technology?, Smart Antenna Systems Tutorial. (0799)	
	110	A Useful Analogy for Adaptive Smart Antennas, Smart Antenna Systems Tutorial, <a href="http://www.iec.org:80/tutorials/smart_ant/topic01.html">http://www.iec.org:80/tutorials/smart_ant/topic01.html</a> . (0801)	
	111	Glossary, Smart Antenna Systems Tutorial, <a href="http://www.iec.org:80/tutorials/smart_ant/glossary.html">http://www.iec.org:80/tutorials/smart_ant/glossary.html</a> . (0802)	
	112	Self-Test, Smart Antenna Systems Tutorial, <a href="http://www.iec.org:80/tutorials/smart_ant/selftest.html">http://www.iec.org:80/tutorials/smart_ant/selftest.html</a> . (0803)	
	113	Spatial Channels, <a href="http://www.arraycomm.com:80/Technology/spacial.html">http://www.arraycomm.com:80/Technology/spacial.html</a> . (0811, 0821, 0823)	
	114	White Papers, <a href="http://www.arraycomm.com:80/Company/white_papers.html">http://www.arraycomm.com:80/Company/white_papers.html</a> . (0813)	
	115	IntelliCell® Products Group, <a href="http://www.arraycomm.com:80/IntelliCell/IntelliCell.html">http://www.arraycomm.com:80/IntelliCell/IntelliCell.html</a> . (0817)	
	116	More on IntelliCell, <a href="http://www.arraycomm.com:80/Technology/more_on.html">http://www.arraycomm.com:80/Technology/more_on.html</a> . (0818)	
	117	Smart Antenna Tutorial, <a href="http://www.arraycomm.com:80/Technology/smart_tech.html">http://www.arraycomm.com:80/Technology/smart_tech.html</a> . (0820)	
	118	Related Virtual Exhibits, Smart Antenna Systems Tutorial, IEC ComForum at WCA 2001: June 25-27, 2001, World Trade Center, Boston, MA, USA. (0825)	
	119	IntelliCell Is the Adaptive Wireless Solution, <a href="https://web.archive.org/web/19990417133013/http://www.arraycomm.com">https://web.archive.org/web/19990417133013/http://www.arraycomm.com</a> . (0827)	
	120	ArrayComm Product Information, <a href="https://web.archive.org/web/19980114005647/http://www.arraycomm.com">https://web.archive.org/web/19980114005647/http://www.arraycomm.com</a> . (0829)	
	121	ArrayComm Technical Breakthroughs, <a href="https://web.archive.org/web/19980114010255/http://www.arraycomm.com">https://web.archive.org/web/19980114010255/http://www.arraycomm.com</a> . (0831)	
	122	ArrayComm Technology and Product Implementation, <a href="https://web.archive.org/web/19980114011423/http://www.arraycomm.com">https://web.archive.org/web/19980114011423/http://www.arraycomm.com</a> . (0834)	
	123	ArrayComm Technology Overview, <a href="https://web.archive.org/web/19990417180607/http://www.arraycomm.com">https://web.archive.org/web/19990417180607/http://www.arraycomm.com</a> . (0836)	
	124	RALEIGH, G.G., et al., "Adaptive Antenna Transmission for Frequency Duplex Digital Wireless Communication", 1997 IEEE, pages 641-646. (0839)	
	125	GERLACH, DEREK, "Adaptive Transmitting Antenna Arrays at the Base Station in Mobile Radio Networks", August 1995, UMI Company, Ann Arbor, MI, 108 pages. (0845; 2575)	

Examiner Signature /GINA M MCKIE/	Date Considered 01/18/2018
*Examiner: Initial if reference considered, whether or not citation is in conformance with MPEP 609. Draw line through citation if not in conformance and not considered. Include copy of this form with next communication to applicant.	

T<sup>1</sup> - Place a check mark in this area when an English language Translation is attached.

ALL REFERENCES CONSIDERED EXCEPT WHERE LINED THROUGH. /G.M.M/

PTO/SB/08 Equivalent

<b>INFORMATION DISCLOSURE STATEMENT BY APPLICANT</b>	Application No.	15/495,539
	Filing Date	April 24, 2017
	First Named Inventor	Marcus Da Silva
	Art Unit	2631
<i>(Multiple sheets used when necessary)</i>		Examiner McKie, Gina M.
SHEET 7 OF 8		Attorney Docket No. 1640-001.203

NON PATENT LITERATURE DOCUMENTS			
Examiner Initials	Cite No.	Include name of the author (in CAPITAL LETTERS), title of the article (when appropriate), title of the item (book, magazine, journal, serial, symposium, catalog, etc.), date, page(s), volume-issue number(s), publisher, city and/or country where published.	T <sup>1</sup>
	126	GERLACH, DEREK et al., "Adaptive Transmitting Antenna Arrays with Feedback", IEEE Signal Processing Letters, Vol. 1, No. 10, October 1994, pages 150-152. (0953; 2683)	
	127	LEHNE, PER H., et al. "An Overview of Smart Antenna Technology For Mobile Communications Systems", IEEE Communications Surveys, <a href="http://www.comsoc.org/pubs/surveys">http://www.comsoc.org/pubs/surveys</a> , Fourth Quarter 1999, Vol. 2, No. 4, pages 2-13. (0956)	
	128	GERLACH, DEREK et al., "Base station transmitting antenna arrays for multipath environments", Signal Processing 54 (1996) pages 59-73. (0968; 2686)	
	129	NAGUIB, AYMAN F., et al. "Capacity Improvement of Base-Station Antenna Arrays Cellular CDMA", 1993 IEEE, pages 1437-1441. (0983)	
	130	LIANG et al; "Forward link antenna diversity using feedback for indoor communication systems", IEEE, 1995 International Conference on Acoustics, Speech, and Signal Processing, Vol. 3, pp. 1753-5. (0993)	
	131	MARIKAR et al.; "Resource Management in Third Generation Mobile Communication Systems Employing Smart Antennas", IEEE INFOCOM 2002, Vol. 3, p. 1461-9. (0996)	
	132	PAULRAJ, Arogyaswami; "Smart antennas for battlefield multimedia wireless networks with dual use applications", Army Research Office, Grant No. DAAH04-95-1-0249, August 15, 1998, 1-22. (1006)	
	133	Anthony S. ACAMPORA et al., "A New Adaptive MAC Layer Protocol for Broadband Packet Wireless Networks in Harsh Fading and Interference Environments", IEEE/ACM Transactions on Networking, Vol. 8, No. 3, June 2000, pages 328-336. (2380)	
	134	Anthony S. ACAMPORA et al., "A New Adaptive MAC Layer Protocol for Wireless ATM Networks in Harsh Fading and Interference Environments", IEEE, 1997, Center for Wireless Communications, University of California, San Diego, pages 410-415. (2389)	
	135	Anthony S. ACAMPORA et al., "A Wireless Network for Wide-Band Indoor Communications", IEEE Journal on Selected Areas in Communications, Vol. SAC-5, No. 5, June 1987, pages 796-805. (2395)	
	136	A. S. ACAMPORA et al., "System Applications for Wireless Indoor Communications", IEEE Communications Magazine, August 1987, Vol. 25, No. 8, pages 11-20. (2405)	
	137	G.J. FOSCHINI et al., "On Limits of Wireless Communications in a Fading Environment When Using Multiple Antennas", Wireless Personal Communications 6, Kluwer Academic Publishers, 1998, Netherlands, pages 311-335. (2550)	
	138	Derek GERLACH et al., "Spectrum Reuse Using Transmitting Antenna Arrays With Feedback", IEEE 1994, Information Systems Lab, Stanford University, pages 97-100. (2701)	
	139	Supplement to IEEE Standard for Information technology – Telecommunications and information exchange between systems – Local and metropolitan area networks – Specific requirements, "Part 11: Wireless LAN Medium Access Control (MAC) and Physical Layer (PHY) specifications, High-speed Physical Layer in the 5 GHz Band", IEEE-SA Standards Board, June 12, 2003, IEEE Std 802.11a-1999(R2003), 91 pages. (2710)	
	140	Supplement to IEEE Standard for Information technology – Telecommunications and information exchange between systems – Local and metropolitan area networks – Specific requirements, "Part 11: Wireless LAN Medium Access Control (MAC) and Physical Layer (PHY) specifications: Higher-Speed Physical Layer Extension in the 2.4 GHz Band", IEEE Std 802.11b-1999 (R2003), Institute of Electrical Engineers, Inc., January 20, 2000, U.S.A., 96 pages. (2801)	
	141	KRISHNAMURTHY, S. et al., "Polling Based Media Access Protocols for Use With Smart Adaptive Array Antennas", Conference Record, International Conference on Universal Personal Communications, Florence, Oct., 1998. (2941)	

Examiner Signature /GINA M MCKIE/	Date Considered 01/18/2018
*Examiner: Initial if reference considered, whether or not citation is in conformance with MPEP 609. Draw line through citation if not in conformance and not considered. Include copy of this form with next communication to applicant.	

T<sup>1</sup> - Place a check mark in this area when an English language Translation is attached.

ALL REFERENCES CONSIDERED EXCEPT WHERE LINED THROUGH. /G.M.M/

PTO/SB/08 Equivalent

<b>INFORMATION DISCLOSURE STATEMENT BY APPLICANT</b>	Application No.	15/495,539	
	Filing Date	April 24, 2017	
	First Named Inventor	Marcus Da Silva	
	Art Unit	2631	
<i>(Multiple sheets used when necessary)</i>		Examiner	McKie, Gina M.
SHEET 8 OF 8		Attorney Docket No.	1640-001.203

**NON PATENT LITERATURE DOCUMENTS**

Examiner Initials	Cite No.	Include name of the author (in CAPITAL LETTERS), title of the article (when appropriate), title of the item (book, magazine, journal, serial, symposium, catalog, etc.), date, page(s), volume-issue number(s), publisher, city and/or country where published.	T <sup>1</sup>
	142	KRISHNAMURTHY, S.V. et al.; "Polling-Based Media Access Protocols for Use with Smart Adaptive Array Antennas," IEEE/ACM Trans. Networking Vol. 9, No. 2, April 2001. (3065)	
	<del>143</del>	<del>JACOBSEN, Arild, Smart Antennas for Dummies, ISBN: 82-423-0388-6, (3079)</del>	
	144	Interface, February 1999, pages 176-181; Interface, March 1999, pages 168-173. (Japanese) (3117)	
	145	WOLNIANSKY, P. W. et al., "V-BLAST: An Architecture for Realizing Very High Data Rates Over the Rich-Scattering Wireless Channel," Proc. URSI ISSSE: 295-300, September 1998. (3593)	
	146	WINTERS, J.H. "Optimum Combining in Digital Mobile Radio with Cochannel Interference", IEEE Journal on Selected Areas in Communications, Vol. SAC-2, No. 4, July 1984. (3607)	
	<del>147</del>	<del>YAMAGUCHI, M. et al., "4 GHz 8x8 Switch Matrix for SDMA System," Kokusai Denshin Denwa Co., Ltd., Japan, p. 170-172. (3661)</del>	
	148	ZHANG, Z. et al., "Performance of a Modified Polling Strategy for Broadband Wireless LANs in a Harsh Fading Environment," IEEE GLOBECOM '91 Conference Record, Dec. 1991, Phoenix. (3675)	
	149	ACAMPORA, A.S. et al., "Media Access Protocols for Use with Smart Adaptive Array Antennas to Enable Wireless Multimedia Applications", 9th Tyrreheanian Workshop on Digital Communications, Lericci (Italy), Sep. 1997. (3842)	
	150	ZHANG, Z. et al., "Performance of a Modified Polling Strategy for Broadband Wireless Access in a Harsh Fading Environment," Telecommunication Systems, Vol. 1, No. 3, 1993, p. 279-294. (3854)	
	<del>151</del>	<del>GERLACH et al, "Base station transmitter antenna arrays with mobile to base feedback", IEEE, Proceedings of 27th Asilomar Conference on Signals, Systems and Computers, Vol. 2, pp. 1432-6 (3870)</del>	
	152	XR COMMUNICATIONS, LLC, dba VIVATO TECHNOLOGIES v. D-LINK SYSTEMS, INC., et al., CASE NO. 8:17-cv-0596-AG(JCGx), Defendants' Invalidity Contentions Pursuant to Standing Patent Rules 2.5 and 2.6, dated Nov. 10, 2017, 85 pages	
	<del>153</del>	<del>Exhibits A1 - A30</del>	
	<del>154</del>	<del>Exhibits B1 - B27</del>	
	<del>155</del>	<del>Exhibits C1 - C27</del>	

Examiner Signature /GINA M MCKIE/	Date Considered 01/18/2018
*Examiner: Initial if reference considered, whether or not citation is in conformance with MPEP 609. Draw line through citation if not in conformance and not considered. Include copy of this form with next communication to applicant.	

T<sup>1</sup> - Place a check mark in this area when an English language Translation is attached.

ALL REFERENCES CONSIDERED EXCEPT WHERE LINED THROUGH. /G.M.M/

Receipt date: 07/07/2017

15/495,539 - GAU: 2631

Doc code: IDS

Doc description: Information Disclosure Statement (IDS) Filed

PTO/SB/08a (03-15)

Approved for use through 07/31/2016. OMB 0651-0031  
U.S. Patent and Trademark Office; U.S. DEPARTMENT OF COMMERCE

Under the Paperwork Reduction Act of 1995, no persons are required to respond to a collection of information unless it contains a valid OMB control number.

<b>INFORMATION DISCLOSURE STATEMENT BY APPLICANT</b> ( Not for submission under 37 CFR 1.99)	Application Number	15495539
	Filing Date	2017-04-24
	First Named Inventor	Marcus DA SILVA
	Art Unit	2631
	Examiner Name	Gina M. MCKIE
	Attorney Docket Number	E1027.800(T).US1D1C1C3

U.S.PATENTS							Remove
Examiner Initial*	Cite No	Patent Number	Kind Code <sup>1</sup>	Issue Date	Name of Patentee or Applicant of cited Document	Pages,Columns,Lines where Relevant Passages or Relevant Figures Appear	
	1	5933421	A	1999-08-03	ALAMOUTI et al		
	2	8412106	B2	2013-04-02	DA SILVA et al.		

If you wish to add additional U.S. Patent citation information please click the Add button. Add

U.S.PATENT APPLICATION PUBLICATIONS							Remove
Examiner Initial*	Cite No	Publication Number	Kind Code <sup>1</sup>	Publication Date	Name of Patentee or Applicant of cited Document	Pages,Columns,Lines where Relevant Passages or Relevant Figures Appear	
	1	20040014429	A1	2004-01-22	GUO		
	2	20010003443	A1	2001-06-14	VELAZQUEZ		

If you wish to add additional U.S. Published Application citation information please click the Add button. Add

FOREIGN PATENT DOCUMENTS								Remove
Examiner Initial*	Cite No	Foreign Document Number <sup>3</sup>	Country Code <sup>2</sup>	Kind Code <sup>4</sup>	Publication Date	Name of Patentee or Applicant of cited Document	Pages,Columns,Lines where Relevant Passages or Relevant Figures Appear	T <sup>5</sup>
	1							

<b>INFORMATION DISCLOSURE STATEMENT BY APPLICANT ( Not for submission under 37 CFR 1.99)</b>	Application Number		15495539
	Filing Date		2017-04-24
	First Named Inventor	Marcus DA SILVA	
	Art Unit		2631
	Examiner Name	Gina M. MCKIE	
	Attorney Docket Number		E1027.800(T).US1D1C1C3

If you wish to add additional Foreign Patent Document citation information please click the Add button

**NON-PATENT LITERATURE DOCUMENTS**

Examiner Initials*	Cite No	Include name of the author (in CAPITAL LETTERS), title of the article (when appropriate), title of the item (book, magazine, journal, serial, symposium, catalog, etc), date, pages(s), volume-issue number(s), publisher, city and/or country where published.	T <sup>5</sup>
	1		

If you wish to add additional non-patent literature document citation information please click the Add button

**EXAMINER SIGNATURE**

Examiner Signature	/GINA M MCKIE/	Date Considered	01/18/2018
--------------------	----------------	-----------------	------------

\*EXAMINER: Initial if reference considered, whether or not citation is in conformance with MPEP 609. Draw line through a citation if not in conformance and not considered. Include copy of this form with next communication to applicant.

<sup>1</sup> See Kind Codes of USPTO Patent Documents at [www.USPTO.GOV](http://www.USPTO.GOV) or MPEP 901.04. <sup>2</sup> Enter office that issued the document, by the two-letter code (WIPO Standard ST.3). <sup>3</sup> For Japanese patent documents, the indication of the year of the reign of the Emperor must precede the serial number of the patent document. <sup>4</sup> Kind of document by the appropriate symbols as indicated on the document under WIPO Standard ST.16 if possible. <sup>5</sup> Applicant is to place a check mark here if English language translation is attached.

<b>INFORMATION DISCLOSURE STATEMENT BY APPLICANT</b> ( Not for submission under 37 CFR 1.99)	Application Number	15495539
	Filing Date	2017-04-24
	First Named Inventor	Marcus DA SILVA
	Art Unit	2631
	Examiner Name	Gina M. MCKIE
	Attorney Docket Number	E1027.800(T).US1D1C1C3

**CERTIFICATION STATEMENT**

Please see 37 CFR 1.97 and 1.98 to make the appropriate selection(s):

That each item of information contained in the information disclosure statement was first cited in any communication from a foreign patent office in a counterpart foreign application not more than three months prior to the filing of the information disclosure statement. See 37 CFR 1.97(e)(1).

**OR**

That no item of information contained in the information disclosure statement was cited in a communication from a foreign patent office in a counterpart foreign application, and, to the knowledge of the person signing the certification after making reasonable inquiry, no item of information contained in the information disclosure statement was known to any individual designated in 37 CFR 1.56(c) more than three months prior to the filing of the information disclosure statement. See 37 CFR 1.97(e)(2).



See attached certification statement.

The fee set forth in 37 CFR 1.17 (p) has been submitted herewith.

A certification statement is not submitted herewith.

**SIGNATURE**

A signature of the applicant or representative is required in accordance with CFR 1.33, 10.18. Please see CFR 1.4(d) for the form of the signature.

Signature	/Nicholas R. Transier/	Date (YYYY-MM-DD)	2017-07-07
Name/Print	Nicholas R. TRANSIER	Registration Number	68743

This collection of information is required by 37 CFR 1.97 and 1.98. The information is required to obtain or retain a benefit by the public which is to file (and by the USPTO to process) an application. Confidentiality is governed by 35 U.S.C. 122 and 37 CFR 1.14. This collection is estimated to take 1 hour to complete, including gathering, preparing and submitting the completed application form to the USPTO. Time will vary depending upon the individual case. Any comments on the amount of time you require to complete this form and/or suggestions for reducing this burden, should be sent to the Chief Information Officer, U.S. Patent and Trademark Office, U.S. Department of Commerce, P.O. Box 1450, Alexandria, VA 22313-1450. **DO NOT SEND FEES OR COMPLETED FORMS TO THIS ADDRESS. SEND TO: Commissioner for Patents, P.O. Box 1450, Alexandria, VA 22313-1450.**



## Privacy Act Statement

The Privacy Act of 1974 (P.L. 93-579) requires that you be given certain information in connection with your submission of the attached form related to a patent application or patent. Accordingly, pursuant to the requirements of the Act, please be advised that: (1) the general authority for the collection of this information is 35 U.S.C. 2(b)(2); (2) furnishing of the information solicited is voluntary; and (3) the principal purpose for which the information is used by the U.S. Patent and Trademark Office is to process and/or examine your submission related to a patent application or patent. If you do not furnish the requested information, the U.S. Patent and Trademark Office may not be able to process and/or examine your submission, which may result in termination of proceedings or abandonment of the application or expiration of the patent.

The information provided by you in this form will be subject to the following routine uses:

1. The information on this form will be treated confidentially to the extent allowed under the Freedom of Information Act (5 U.S.C. 552) and the Privacy Act (5 U.S.C. 552a). Records from this system of records may be disclosed to the Department of Justice to determine whether the Freedom of Information Act requires disclosure of these records.
2. A record from this system of records may be disclosed, as a routine use, in the course of presenting evidence to a court, magistrate, or administrative tribunal, including disclosures to opposing counsel in the course of settlement negotiations.
3. A record in this system of records may be disclosed, as a routine use, to a Member of Congress submitting a request involving an individual, to whom the record pertains, when the individual has requested assistance from the Member with respect to the subject matter of the record.
4. A record in this system of records may be disclosed, as a routine use, to a contractor of the Agency having need for the information in order to perform a contract. Recipients of information shall be required to comply with the requirements of the Privacy Act of 1974, as amended, pursuant to 5 U.S.C. 552a(m).
5. A record related to an International Application filed under the Patent Cooperation Treaty in this system of records may be disclosed, as a routine use, to the International Bureau of the World Intellectual Property Organization, pursuant to the Patent Cooperation Treaty.
6. A record in this system of records may be disclosed, as a routine use, to another federal agency for purposes of National Security review (35 U.S.C. 181) and for review pursuant to the Atomic Energy Act (42 U.S.C. 218(c)).
7. A record from this system of records may be disclosed, as a routine use, to the Administrator, General Services, or his/her designee, during an inspection of records conducted by GSA as part of that agency's responsibility to recommend improvements in records management practices and programs, under authority of 44 U.S.C. 2904 and 2906. Such disclosure shall be made in accordance with the GSA regulations governing inspection of records for this purpose, and any other relevant (i.e., GSA or Commerce) directive. Such disclosure shall not be used to make determinations about individuals.
8. A record from this system of records may be disclosed, as a routine use, to the public after either publication of the application pursuant to 35 U.S.C. 122(b) or issuance of a patent pursuant to 35 U.S.C. 151. Further, a record may be disclosed, subject to the limitations of 37 CFR 1.14, as a routine use, to the public if the record was filed in an application which became abandoned or in which the proceedings were terminated and which application is referenced by either a published application, an application open to public inspections or an issued patent.
9. A record from this system of records may be disclosed, as a routine use, to a Federal, State, or local law enforcement agency, if the USPTO becomes aware of a violation or potential violation of law or regulation.


**EAST Search History**

**EAST Search History (Prior Art)**

<b>Ref #</b>	<b>Hits</b>	<b>Search Query</b>	<b>DBs</b>	<b>Default Operator</b>	<b>Plurals</b>	<b>Time Stamp</b>
L1	1	(remote NEAR2 station) WITH weighting WITH beamform\$3	US-PGPUB; USPAT; USOCR; FPRS; EPO; JPO; DERWENT; IBM_TDB	OR	OFF	2018/01/19 21:51

**1/ 19/ 2018 9:57:44 PM**

**C:\ Users\ gmckie\ Documents\ EAST\ Workspaces\ 15269852.w sp**

<b>Search Notes</b>  	<b>Application/Control No.</b>  15495539	<b>Applicant(s)/Patent Under Reexamination</b>  DA SILVA ET AL.
	<b>Examiner</b>  GINA MCKIE	<b>Art Unit</b>  2631

CPC- SEARCHED		
Symbol	Date	Examiner
H04L7/042, H04L27/2675 (EAST keyword search)	6/22/2017	gmckie

CPC COMBINATION SETS - SEARCHED		
Symbol	Date	Examiner


US CLASSIFICATION SEARCHED			
Class	Subclass	Date	Examiner

\* See search history printout included with this form or the SEARCH NOTES box below to determine the scope of the search.

SEARCH NOTES		
Search Notes	Date	Examiner
Performed double patenting search in EAST	6/21/2017	gmckie
Performed initial prior art search in EAST	6/21/2017	gmckie
Updated prior art search in EAST	1/19/2018	gmckie

INTERFERENCE SEARCH			
US Class/ CPC Symbol	US Subclass / CPC Group	Date	Examiner

--	--

<b><i>Index of Claims</i></b> 	<b>Application/Control No.</b> 15495539	<b>Applicant(s)/Patent Under Reexamination</b> DA SILVA ET AL.
	<b>Examiner</b> GINA MCKIE	<b>Art Unit</b> 2631

✓	<b>Rejected</b>	-	<b>Cancelled</b>	N	<b>Non-Elected</b>	A	<b>Appeal</b>
=	<b>Allowed</b>	÷	<b>Restricted</b>	I	<b>Interference</b>	O	<b>Objected</b>

Claims renumbered in the same order as presented by applicant
  CPA
  T.D.
  R.1.47

CLAIM		DATE							
Final	Original	06/21/2017	01/19/2018						
	1	✓	✓						
	2	✓	✓						
	3	✓	✓						
	4	✓	✓						
	5	✓	✓						
	6	✓	✓						
	7	✓	✓						
	8	✓	✓						
	9	✓	✓						
	10	✓	✓						
	11	✓	✓						
	12	✓	✓						
	13	✓	✓						
	14	✓	✓						
	15	✓	✓						
	16	✓	✓						
	17	✓	✓						
	18	✓	✓						
	19	✓	✓						
	20	✓	✓						



UNITED STATES PATENT AND TRADEMARK OFFICE

UNITED STATES DEPARTMENT OF COMMERCE
United States Patent and Trademark Office
Address: COMMISSIONER FOR PATENTS
P.O. Box 1450
Alexandria, Virginia 22313-1450
www.uspto.gov

Table with 4 columns: APPLICATION NUMBER (15/495,539), PATENT NUMBER, GROUP ART UNIT (2631), REQUEST ID (53048)

PAIR Correspondence Address/Fee Address Change

The following fields have been changed to Customer Number 22145 on 12/12/2017 via Private PAIR in view of the certification copied below that authorized the change.

- Correspondence Address

The address for Customer Number 22145 is:

22145
KLEIN, O'NEILL & SINGH, LLP
16755 VON KARMAN AVENUE
SUITE 275
IRVINE, CA 92606

I certify, in accordance with 37 CFR 1.4(d)(4) that I am:

An attorney or Agent of Record registered to practice before the Patent and Trademark Office who has been given power of attorney in this application

Table with 2 columns: Field (Signature, Name, Registration Number) and Value (/Vladislav Z. Teplitskiy/, Vladislav Z. Teplitskiy, 68069)

<b>INFORMATION DISCLOSURE STATEMENT BY APPLICANT</b>	Application No.	15/495,539	
	Filing Date	April 24, 2017	
	First Named Inventor	Marcus Da Silva	
	Art Unit	2631	
<i>(Multiple sheets used when necessary)</i>		Examiner	McKie, Gina M.
SHEET 1 OF 8		Attorney Docket No.	1640-001.203

U.S. PATENT DOCUMENTS					
Examiner Initials	Cite No.	Document Number <i>Number - Kind Code (if known)</i> Example: 1,234,567 B1	Publication Date MM-DD-YYYY	Name of Patentee or Applicant	Pages, Columns, Lines Where Relevant Passages or Relevant Figures Appear
	1	4,750,147	06-07-1998	Roy, III et al.	
	2	4,965,732	10-23-1990	Roy, III et al.	
	3	5,095,531	03-10-1992	Ito	
	4	5,345,599 A	09-06-1994	Paulraj et al.	
	5	5,471,647	11-28-1995	Gerlach et al.	
	6	5,515,378 A	05-07-1996	Roy, III et al.	
	7	5,546,090	08-13-1996	Roy, III et al.	
	8	5,553,074	09-03-1996	Acampora	
	9	5,592,490	01-07-1997	Barratt et al.	
	10	5,602,555	02-11-1997	Searle et al.	
	11	5,603,089	02-11-1997	Searle et al.	
	12	5,634,199	05-27-1997	Gerlach et al.	
	13	5,642,353 A	06-24-1997	Roy, III et al.	
	14	5,649,293	07-15-1997	Reed	
	15	5,687,194 A	11-11-1997	Paneth et al.	
	16	5,697,066	12-09-1997	Acampora	
	17	5,739,788	04-14-1998	Dybdal et al.	
	18	5,828,658 A	10-27-1998	Ottersten et al.	
	19	5,886,988	03-23-1999	Yun et al.	
	20	5,890,067	03-30-1999	Chang et al.	
	21	5,914,946 A	06-22-1999	Avidor et al.	
	22	5,966,094	10-12-1999	Ward et al.	
	23	6,006,110	12-21-1999	Raleigh	
	24	6,067,290	05-23-2000	Paulraj et al.	
	25	6,101,399	08-08-2000	Raleigh et al.	
	26	6,219,561	04-17-2001	Raleigh	
	27	6,233,466	05-15-2001	Wong et al.	
	28	6,330,460	12-11-2001	Wong et al.	
	29	6,345,188	02-05-2002	Keskitalo et al.	

Examiner Signature	Date Considered
<p><b>*Examiner:</b> Initial if reference considered, whether or not citation is in conformance with MPEP 609. Draw line through citation if not in conformance and not considered. Include copy of this form with next communication to applicant.</p>	

T<sup>1</sup> - Place a check mark in this area when an English language Translation is attached.

<b>INFORMATION DISCLOSURE STATEMENT BY APPLICANT</b>	Application No.	15/495,539	
	Filing Date	April 24, 2017	
	First Named Inventor	Marcus Da Silva	
	Art Unit	2631	
<i>(Multiple sheets used when necessary)</i>		Examiner	McKie, Gina M.
SHEET 2 OF 8		Attorney Docket No.	1640-001.203

U.S. PATENT DOCUMENTS					
Examiner Initials	Cite No.	Document Number <i>Number - Kind Code (if known)</i> Example: 1,234,567 B1	Publication Date MM-DD-YYYY	Name of Patentee or Applicant	Pages, Columns, Lines Where Relevant Passages or Relevant Figures Appear
	30	6,351,499	02-26-2002	Paulraj et al.	
	31	6,438,376	08-20-2002	Elliott et al.	
	32	6,564,036	05-13-2003	Kasapi	
	33	6,611,695	08-26-2003	Periyalwar	
	34	6,665,545 B1	12-16-2003	Raleigh et al.	
	35	6,667,712	12-23-2003	Ericson et al.	
	36	6,687,492	02-03-2004	Sugar et al.	
	37	6,694,154	02-17-2004	Molnar et al.	
	38	6,748,216	06-08-2004	Lee	
	39	6,795,409	09-21-2004	Youssefmir et al.	
	40	6,823,174	11-23-2004	Masenten et al.	
	41	6,850,741	02-01-2005	Lei et al.	
	42	6,853,333	02-08-2005	Ericson et al.	
	43	7,020,110	03-28-2006	Walton et al.	
	44	7,031,336	04-18-2006	Scherzer et al.	
	45	7,054,662	05-30-2006	Judson	
	46	7,062,294	06-13-2006	Rogard et al.	
	47	7,133,380	11-07-2006	Winters et al.	
	48	7,289,826	10-30-2007	Hovers et al.	
	49	7,346,365	03-18-2008	Hovers et al.	
	50	7,492,743	02-17-2009	Uhlik	
	51	7,529,305	05-05-2009	Tong et al.	
	52	2001/0033600	10-25-2001	Yang et al.	
	53	2002/0034967	03-21-2002	Taniguchi et al.	
	54	2003/0017853	01-23-2003	Kanamaluru et al.	

FOREIGN PATENT DOCUMENTS						
Examiner Initials	Cite No.	Foreign Patent Document <i>Country Code-Number-Kind Code</i> Example: JP 1234567 A1	Publication Date MM-DD-YYYY	Name of Patentee or Applicant	Pages, Columns, Lines Where Relevant Passages or Relevant Figures Appear	T <sup>1</sup>

Examiner Signature	Date Considered
<p><b>*Examiner:</b> Initial if reference considered, whether or not citation is in conformance with MPEP 609. Draw line through citation if not in conformance and not considered. Include copy of this form with next communication to applicant.</p>	

T<sup>1</sup> - Place a check mark in this area when an English language Translation is attached.

<b>INFORMATION DISCLOSURE STATEMENT BY APPLICANT</b>	Application No.	15/495,539	
	Filing Date	April 24, 2017	
	First Named Inventor	Marcus Da Silva	
	Art Unit	2631	
<i>(Multiple sheets used when necessary)</i>		Examiner	McKie, Gina M.
SHEET 3 OF 8		Attorney Docket No.	1640-001.203

FOREIGN PATENT DOCUMENTS						
Examiner Initials	Cite No.	Foreign Patent Document Country Code-Number-Kind Code Example: JP 1234567 A1	Publication Date MM-DD-YYYY	Name of Patentee or Applicant	Pages, Columns, Lines Where Relevant Passages or Relevant Figures Appear	T <sup>1</sup>
	55	WO 00/38455 A1	06-29-2000	Telefonaktiebolaget LM Ericsson		
	56	WO 00/72464 A1	11-30-2000	Nokia Networks		
	57	WO 01/10156 A1	02-08-2001	Gigabit Wireless, Inc.		
	58	WO 01/010156 A1	02-08-2001	Iospan Wireless, Inc.		
	59	WO 03/075396 A2	09-12-2003	Cognio, Inc.		
	60	WO 96/21117	07-11-1996	Automotive Products France S.A.		
	61	WO 97/00543 A1	01-03-1997	Watkins-Johnson Company		
	62	WO 97/33388 A1	09-12-1997	Watkins-Johnson Company		
	63	WO 98/09381 A1	03-05-1998	The Board of Trustees of the Leland Stanford Junior University		
	64	WO 98/18271 A3	04-30-1998	Watkins Johnson Company		
	65	WO 99/21391 A2	04-29-1999	Radio Design Innovation TJ AB		
	66	EP 0817517 A1	01-07-1998	NTT Mobile Communications Network Inc.		

NON PATENT LITERATURE DOCUMENTS			
Examiner Initials	Cite No.	Include name of the author (in CAPITAL LETTERS), title of the article (when appropriate), title of the item (book, magazine, journal, serial, symposium, catalog, etc.), date, page(s), volume-issue number(s), publisher, city and/or country where published.	T <sup>1</sup>
	67	"Part 11: Wireless LAN Medium Access Control (MAC) and Physical Layer (PHY) specifications: Higher-Speed Physical Layer Extension in the 2.4 GHz Band", Supplement to IEEE Standard for Information technology - Telecommunications and information exchange between systems - Local and metropolitan area networks - Specific requirements. IEEE Std 802.11b-1999(R2003); Sponsor LAN/MAN Standards Committee of the IEEE Computer Society; Reaffirmed 12 June 2003, Approved 16 September 1999, IEEE-SA Standards Board. (0001)	
	68	MARTIN COOPER, "A Layman's Guide to Cellular, Annual Review of Communications", 1996, pages 993-997. (0097; 2478)	
	69	ANDERSON et al., "An Adaptive Array for Mobile Communication Systems", IEEE Transactions On Vehicular Technology, Vol. 40, No. 1, February 1991, pages 230-236. (0102; 2415)	
	70	RICHARD H. ROY, "Application of Smart Antenna Technology in Wireless Communication Systems", pages 1-6. (0109; 0115; 3059)	
	71	BJORN OTTERSTEN, "Array Processing for Wireless Communications", 8th IEEE Signal Processing Workshop on Statistical Signal and Array Processing. (0121; 2974)	
	72	G. J. FOSCHINI et al., "BLAST: Bell Labs Layered Space-Time, An Architecture for Realizing Very High Data Rates Over Fading Wireless Channels", <a href="https://web.archive.org/web/19990221074508/https://www.bell-labs.com/pr">https://web.archive.org/web/19990221074508/https://www.bell-labs.com/pr</a> , Lucent Technologies, 1998, 3 pages. (0130; 2528)	

Examiner Signature	Date Considered
*Examiner: Initial if reference considered, whether or not citation is in conformance with MPEP 609. Draw line through citation if not in conformance and not considered. Include copy of this form with next communication to applicant.	

T<sup>1</sup> - Place a check mark in this area when an English language Translation is attached.



<b>INFORMATION DISCLOSURE STATEMENT BY APPLICANT</b>	Application No.	15/495,539	
	Filing Date	April 24, 2017	
	First Named Inventor	Marcus Da Silva	
	Art Unit	2631	
<i>(Multiple sheets used when necessary)</i>		Examiner	McKie, Gina M.
SHEET 4 OF 8		Attorney Docket No.	1640-001.203

NON PATENT LITERATURE DOCUMENTS			
Examiner Initials	Cite No.	Include name of the author (in CAPITAL LETTERS), title of the article (when appropriate), title of the item (book, magazine, journal, serial, symposium, catalog, etc.), date, page(s), volume-issue number(s), publisher, city and/or country where published.	T <sup>1</sup>
	73	BRANDENBURG, L. H. et al., "Capacity of the Gaussian Channel With Memory: The Multivariate Case", The Bell System Technical Journal, Vol. 63, No. 5, May-June 1974, pages 745-764. (0133; 2436)	
	74	Dean CHAPMAN, "First-Hand: Sidelobe Cancellers and the Like", <a href="http://ethw.org/First-Hand:Sidelobe_Cancellers_and_the_Like">http://ethw.org/First-Hand:Sidelobe_Cancellers_and_the_Like</a> , April 12, 2017, 4 pages. (0167; 2474)	
	75	LI, HANG et al., "Coded Beamforming for Block Fading Vector Channel", 2001 IEEE, pages 1137-1141. (0171; 2949)	
	76	DANDEKAR, K.R. et al., "Effect of mutual coupling on direction finding in smart antenna applications", Electronics Letters, Vol. 36, No. 22, October 26, 2000, pages 1889-1891. (0176; 2487)	
	77	L. BIGLER, H.P. et al., "Experimental Direction of Arrival and Spatial Signature Measurements at 900 MHz for Smart Antenna Systems", 1995 IEEE, pages 55-58. (0179; 2432)	
	78	JENG, SHIANN-SHIUN et al., "Experimental Evaluation of Smart Antenna System Performance for Capacity Improvement", 1997 IEEE, pages 369-373. (0183; 2897)	
	79	JENG, SHIANN-SHIUN et al., "Experimental Evaluation of Smart Antenna System Performance for Wireless Communications", IEEE Transactions on Antennas and Propagation, Vol. 46, No. 6, June 1998, pages 749-757. (0188; 2902)	
	80	XU, G. et al., "Experimental Studies of Space-Division-Multiple-Access Schemes for Spectral Efficient Wireless Communications", 1994 IEEE, pages 800-804. (0197; 988)	
	81	JENG, SHIANN-SHIUN et al., "Experimental Studies of Spatial Signature Variation at 900 MHz for Smart Antenna Systems", IEEE Transactions on Antennas and Propagation, Vol. 46, No. 7, July 1998, pages 953-962. (0202; 2911)	
	82	FENN, ALAN J. et al., "The Development of Phased-Array Radar Technology", Lincoln Laboratory Journal, Vol. 12, No. 2, 2000, pages 321-340. (0212; 2508)	
	83	FOSCHINI, GERARD J., "Layered Space-Time Architecture for Wireless Communication in a Fading Environment When Using Multi-Element Antennas", Bell Labs Technical Journal, Autumn 1996, pages 41-59. (0232; 2531)	
	84	"Part 11: Wireless LAN Medium Access Control (MAC) and Physical Layer (PHY) specifications High-speed Physical Layer in the 5 GHz Band", Supplement to IEEE Standard for Information technology - Telecommunications and information exchange between systems - Local and metropolitan area networks - Specific requirements. IEEE Std 802.11a-1999(R2003); Sponsor LAN/MAN Standards Committee of the IEEE Computer Society; Reaffirmed 12 June 2003, IEEE-SA Standards Board. (0251)	
	85	COOPER, Martin, et al., "Intelligent Antennas: Spatial Division Multiple Access", Annual Review of Communications, 1996, pages 999-1002. (0342; 2483)	
	86	KAYE, A. ROGER, et al., "Transmission of Multiplexed PAM Signals Over Multiple Channel and Diversity Systems", IEEE Transactions on Communication Technology, Vol. Com-18, No. 5, October 1970, pages 520-526. (0346; 2934)	
	87	KANG, JOONHYUK, et al., "Low Complexity Array Response Vector Estimation For Smart Antenna Systems, 2000 IEEE, pages 841-845. (0353; 2921)	
	88	DANDEKAR, KAPIL R., et al., "Modeling and Prediction of the Wireless Vector Channel Encountered by Smart Antenna Systems", Microwave and Optical Technology Letters, Vol. 35, No. 4, November 20, 2002, pages 281-283. (0358; 2490)	

Examiner Signature	Date Considered
*Examiner: Initial if reference considered, whether or not citation is in conformance with MPEP 609. Draw line through citation if not in conformance and not considered. Include copy of this form with next communication to applicant.	

T<sup>1</sup> - Place a check mark in this area when an English language Translation is attached.

<b>INFORMATION DISCLOSURE STATEMENT BY APPLICANT</b>	Application No.	15/495,539
	Filing Date	April 24, 2017
	First Named Inventor	Marcus Da Silva
	Art Unit	2631
<i>(Multiple sheets used when necessary)</i>	Examiner	McKie, Gina M.
SHEET 5 OF 8	Attorney Docket No.	1640-001.203

NON PATENT LITERATURE DOCUMENTS			
Examiner Initials	Cite No.	Include name of the author (in CAPITAL LETTERS), title of the article (when appropriate), title of the item (book, magazine, journal, serial, symposium, catalog, etc.), date, page(s), volume-issue number(s), publisher, city and/or country where published.	T <sup>1</sup>
	89	SWALES, S.C., et al., "Multi-Beam Adaptive Base-Station Antennas For Cellular Land Mobile Radio Systems", 1989 IEEE 39 <sup>th</sup> Vehicular Technology Conference, San Francisco, Vol. 1, pages 341-348. (0361; 0475; 3108)	
	90	YANG, WEIDONG, et al., "New Method for Designing Smart Antenna Downlink Weighting Vectors Based on the Filter Bank Concept", SPIE Vol. 3162, pages 240-250. (0369; 3664)	
	91	BALABAN, PHILIP, et al., "Optimum Diversity Combining and Equalization In Digital Data Transmission with Applications to Cellular Mobile Radio - Part 1: Theoretical Considerations", IEEE Transactions on Communications, Vol. 40, No. 5, May 1992, pages 885-894. (0380; 2422)	
	92	NAGUIB, AYMAN F., et al., "Performance of CDMA Cellular Networks With Base-Station Antenna Arrays: The Downlink", 1994 IEEE, pages 795-799. (0390; 2959)	
	93	RALEIGH, GREGORY, et al., "Characterization of Fast Fading Vector Channels for Multi-Antenna Communication Systems". (0395; 3032)	
	94	RALEIGH, GREGORY G., et al., "Spatia-Temporal Coding for Wireless Communication", IEEE Transactions on Communications, Vol. 46, No. 3, March 1998, pages 357-366. (0400; 3037)	
	95	CADZOW, J.A., et al., "Resolution of Coherent Signals Using A Linear Array", 1987 IEEE, pages 1597-1600. (0410; 2470)	
	96	REUDINK, D.O., et al., "A Scanning Spot-Beam Satellite System", The Bell System Technical Journal, Vol. 56, No. 8, October 1997, pages 1549-1560. (0414; 3047)	
	97	NOWICKI, DAVID, et al., "Smart Antenna Strategies", Mobile Communications Int'l, April 1995, pages 1-10. (0426; 2964)	
	98	XU, GUANGHAN, et al., "Smart Antenna Systems for Wireless Communications", 1998 IEEE, pages 631-634. (0436; 3657)	
	99	PAULRAJ, AROGYASWAMI J., et al., "Space-Time Processing for Wireless Communications", IEEE Signal Processing Magazine, November 1997, pages 49-83. (0440; 2983)	
	100	WINTERS, JACK H., et al., "The Impact of Antenna Diversity on the Capacity of Wireless Communication Systems", IEEE Transactions on Communications, Vol. 42, No. 2/3/4, Feb/March/April 1994, pages 1740-1751. (0484; 3619)	
	101	GOLDBURG, MARK, et al., "The Impacts of SDMA on PCS System Design", IEEE, 1994, Session 1.10, ArrayComm, Inc., Santa Clara, CA, pages 242-246. (0496; 2705)	
	102	LI, HANG, et al., "Transmission Optimization Over Flat Rayleigh Fading Channel with Multiple Antennas", 1999 IEEE, pages 210-214. (0501; 2954)	
	103	VAN ETTEN W., "Maximum Likelihood Receiver for Multiple Channel Transmission Systems", IEEE Transactions on Communications, February 1976, pages 276-283. (0767; 3599)	
	104	KAVAK, ADNAN, et al., "Vector Channels for Smart Antennas-Measurements, Statistical Modeling, and Directional Properties in Outdoor Environments", IEEE Transactions on Microwave Theory and Techniques, Vol. 48, No. 6, June 2000, pages 930-937. (0775; 2926)	
	105	Antennas and Antenna Systems, Smart Antenna Systems Tutorial, <a href="http://www.iec.org:80/tutorials/smart_ant/topic02.html">http://www.iec.org:80/tutorials/smart_ant/topic02.html</a> . (0783)	
	106	Correct Answers, Smart Antenna Systems Tutorial, <a href="http://www.iec.org:80/tutorials/smart_ant/answers.html">http://www.iec.org:80/tutorials/smart_ant/answers.html</a> . (0788)	

Examiner Signature	Date Considered
*Examiner: Initial if reference considered, whether or not citation is in conformance with MPEP 609. Draw line through citation if not in conformance and not considered. Include copy of this form with next communication to applicant.	

T<sup>1</sup> - Place a check mark in this area when an English language Translation is attached.

<b>INFORMATION DISCLOSURE STATEMENT BY APPLICANT</b>	Application No.	15/495,539
	Filing Date	April 24, 2017
	First Named Inventor	Marcus Da Silva
	Art Unit	2631
<i>(Multiple sheets used when necessary)</i>	Examiner	McKie, Gina M.
SHEET 6 OF 8	Attorney Docket No.	1640-001.203

NON PATENT LITERATURE DOCUMENTS			
Examiner Initials	Cite No.	Include name of the author (in CAPITAL LETTERS), title of the article (when appropriate), title of the item (book, magazine, journal, serial, symposium, catalog, etc.), date, page(s), volume-issue number(s), publisher, city and/or country where published.	T <sup>1</sup>
	107	Signal Propagation: Multipath And Cochannel Interference, Smart Antenna Systems Tutorial. (0791; 0806)	
	108	What Is a Smart Antenna System?, Smart Antenna Systems Tutorial, <a href="http://www.iec.org:80/tutorials/smart_ant/topic03.html">http://www.iec.org:80/tutorials/smart_ant/topic03.html</a> . (0796)	
	109	Who Can Use Smart Antenna Technology?, Smart Antenna Systems Tutorial. (0799)	
	110	A Useful Analogy for Adaptive Smart Antennas, Smart Antenna Systems Tutorial, <a href="http://www.iec.org:80/tutorials/smart_ant/topic01.html">http://www.iec.org:80/tutorials/smart_ant/topic01.html</a> . (0801)	
	111	Glossary, Smart Antenna Systems Tutorial, <a href="http://www.iec.org:80/tutorials/smart_ant/glossary.html">http://www.iec.org:80/tutorials/smart_ant/glossary.html</a> . (0802)	
	112	Self-Test, Smart Antenna Systems Tutorial, <a href="http://www.iec.org:80/tutorials/smart_ant/selftest.html">http://www.iec.org:80/tutorials/smart_ant/selftest.html</a> . (0803)	
	113	Spatial Channels, <a href="http://www.arraycomm.com:80/Technology/spacial.html">http://www.arraycomm.com:80/Technology/spacial.html</a> . (0811, 0821, 0823)	
	114	White Papers, <a href="http://www.arraycomm.com:80/Company/white_papers.html">http://www.arraycomm.com:80/Company/white_papers.html</a> . (0813)	
	115	IntelliCell® Products Group, <a href="http://www.arraycomm.com:80/IntelliCell/IntelliCell.html">http://www.arraycomm.com:80/IntelliCell/IntelliCell.html</a> . (0817)	
	116	More on IntelliCell, <a href="http://www.arraycomm.com:80/Technology/more_on.html">http://www.arraycomm.com:80/Technology/more_on.html</a> . (0818)	
	117	Smart Antenna Tutorial, <a href="http://www.arraycomm.com:80/Technology/smart_tech.html">http://www.arraycomm.com:80/Technology/smart_tech.html</a> . (0820)	
	118	Related Virtual Exhibits, Smart Antenna Systems Tutorial, IEC ComForum at WCA 2001: June 25-27, 2001, World Trade Center, Boston, MA, USA. (0825)	
	119	IntelliCell Is the Adaptive Wireless Solution, <a href="https://web.archive.org/web/19990417133013/http://www.arraycomm.com:...">https://web.archive.org/web/19990417133013/http://www.arraycomm.com:...</a> (0827)	
	120	ArrayComm Product Information, <a href="https://web.archive.org/web/19980114005647/http://www.arraycomm.com:...">https://web.archive.org/web/19980114005647/http://www.arraycomm.com:...</a> (0829)	
	121	ArrayComm Technical Breakthroughs, <a href="https://web.archive.org/web/19980114010255/http://www.arraycomm.com:...">https://web.archive.org/web/19980114010255/http://www.arraycomm.com:...</a> (0831)	
	122	ArrayComm Technology and Product Implementation, <a href="https://web.archive.org/web/19980114011423/http://www.arraycomm.com:...">https://web.archive.org/web/19980114011423/http://www.arraycomm.com:...</a> (0834)	
	123	ArrayComm Technology Overview, <a href="https://web.archive.org/web/19990417180607/http://www.arraycomm.com:...">https://web.archive.org/web/19990417180607/http://www.arraycomm.com:...</a> (0836)	
	124	RALEIGH, G.G., et al., "Adaptive Antenna Transmission for Frequency Duplex Digital Wireless Communication", 1997 IEEE, pages 641-646. (0839)	
	125	GERLACH, DEREK, "Adaptive Transmitting Antenna Arrays at the Base Station in Mobile Radio Networks", August 1995, UMI Company, Ann Arbor, MI, 108 pages. (0845; 2575)	

Examiner Signature	Date Considered
<p><b>*Examiner:</b> Initial if reference considered, whether or not citation is in conformance with MPEP 609. Draw line through citation if not in conformance and not considered. Include copy of this form with next communication to applicant.</p>	

T<sup>1</sup> - Place a check mark in this area when an English language Translation is attached.

<b>INFORMATION DISCLOSURE STATEMENT BY APPLICANT</b>	Application No.	15/495,539
	Filing Date	April 24, 2017
	First Named Inventor	Marcus Da Silva
	Art Unit	2631
<i>(Multiple sheets used when necessary)</i>	Examiner	McKie, Gina M.
SHEET 7 OF 8	Attorney Docket No.	1640-001.203

NON PATENT LITERATURE DOCUMENTS			
Examiner Initials	Cite No.	Include name of the author (in CAPITAL LETTERS), title of the article (when appropriate), title of the item (book, magazine, journal, serial, symposium, catalog, etc.), date, page(s), volume-issue number(s), publisher, city and/or country where published.	T <sup>1</sup>
	126	GERLACH, DEREK et al., "Adaptive Transmitting Antenna Arrays with Feedback", IEEE Signal Processing Letters, Vol. 1, No. 10, October 1994, pages 150-152. (0953; 2683)	
	127	LEHNE, PER H., et al. "An Overview of Smart Antenna Technology For Mobile Communications Systems", IEEE Communications Surveys, <a href="http://www.comsoc.org/pubs/surveys">http://www.comsoc.org/pubs/surveys</a> , Fourth Quarter 1999, Vol. 2, No. 4, pages 2-13. (0956)	
	128	GERLACH, DEREK et al., "Base station transmitting antenna arrays for multipath environments", Signal Processing 54 (1996) pages 59-73. (0968; 2686)	
	129	NAGUIB, AYMAN F., et al. "Capacity Improvement of Base-Station Antenna Arrays Cellular CDMA", 1993 IEEE, pages 1437-1441. (0983)	
	130	LIANG et al; "Forward link antenna diversity using feedback for indoor communication systems", IEEE, 1995 International Conference on Acoustics, Speech, and Signal Processing, Vol. 3, pp. 1753-5. (0993)	
	131	MARIKAR et al.; "Resource Management in Third Generation Mobile Communication Systems Employing Smart Antennas", IEEE INFOCOM 2002, Vol. 3, p. 1461-9. (0996)	
	132	PAULRAJ, Arogyaswami; "Smart antennas for battlefield multimedia wireless networks with dual use applications", Army Research Office, Grant No. DAAH04-95-1-0249, August 15, 1998, 1-22. (1006)	
	133	Anthony S. ACAMPORA et al., "A New Adaptive MAC Layer Protocol for Broadband Packet Wireless Networks in Harsh Fading and Interference Environments", IEEE/ACM Transactions on Networking, Vol. 8, No. 3, June 2000, pages 328-336. (2380)	
	134	Anthony S. ACAMPORA et al., "A New Adaptive MAC Layer Protocol for Wireless ATM Networks in Harsh Fading and Interference Environments", IEEE, 1997, Center for Wireless Communications, University of California, San Diego, pages 410-415. (2389)	
	135	Anthony S. ACAMPORA et al., "A Wireless Network for Wide-Band Indoor Communications", IEEE Journal on Selected Areas in Communications, Vol. SAC-5, No. 5, June 1987, pages 796-805. (2395)	
	136	A. S. ACAMPORA et al., "System Applications for Wireless Indoor Communications", IEEE Communications Magazine, August 1987, Vol. 25, No. 8, pages 11-20. (2405)	
	137	G.J. FOSCHINI et al., "On Limits of Wireless Communications in a Fading Environment When Using Multiple Antennas", Wireless Personal Communications 6, Kluwer Academic Publishers, 1998, Netherlands, pages 311-335. (2550)	
	138	Derek GERLACH et al., "Spectrum Reuse Using Transmitting Antenna Arrays With Feedback", IEEE 1994, Information Systems Lab, Stanford University, pages 97-100. (2701)	
	139	Supplement to IEEE Standard for Information technology – Telecommunications and information exchange between systems – Local and metropolitan area networks – Specific requirements, "Part 11: Wireless LAN Medium Access Control (MAC) and Physical Layer (PHY) specifications, High-speed Physical Layer in the 5 GHz Band", IEEE-SA Standards Board, June 12, 2003, IEEE Std 802.11a-1999(R2003), 91 pages. (2710)	
	140	Supplement to IEEE Standard for Information technology – Telecommunications and information exchange between systems – Local and metropolitan area networks – Specific requirements, "Part 11: Wireless LAN Medium Access Control (MAC) and Physical Layer (PHY) specifications: Higher-Speed Physical Layer Extension in the 2.4 GHz Band", IEEE Std 802.11b-1999 (R2003), Institute of Electrical Engineers, Inc., January 20, 2000, U.S.A., 96 pages. (2801)	
	141	KRISHNAMURTHY, S. et al., "Polling Based Media Access Protocols for Use With Smart Adaptive Array Antennas", Conference Record, International Conference on Universal Personal Communications, Florence, Oct., 1998. (2941)	

Examiner Signature	Date Considered
*Examiner: Initial if reference considered, whether or not citation is in conformance with MPEP 609. Draw line through citation if not in conformance and not considered. Include copy of this form with next communication to applicant.	

T<sup>1</sup> - Place a check mark in this area when an English language Translation is attached.

<b>INFORMATION DISCLOSURE STATEMENT BY APPLICANT</b>	Application No.	15/495,539
	Filing Date	April 24, 2017
	First Named Inventor	Marcus Da Silva
	Art Unit	2631
<i>(Multiple sheets used when necessary)</i>	Examiner	McKie, Gina M.
SHEET 8 OF 8	Attorney Docket No.	1640-001.203

NON PATENT LITERATURE DOCUMENTS			
Examiner Initials	Cite No.	Include name of the author (in CAPITAL LETTERS), title of the article (when appropriate), title of the item (book, magazine, journal, serial, symposium, catalog, etc.), date, page(s), volume-issue number(s), publisher, city and/or country where published.	T <sup>1</sup>
	142	KRISHNAMURTHY, S.V. et al.; "Polling-Based Media Access Protocols for Use with Smart Adaptive Array Antennas," IEEE/ACM Trans. Networking Vol. 9, No. 2, April 2001. (3065)	
	143	JACOBSEN, Arild, Smart Antennas for Dummies, ISBN: 82-423-0388-6. (3079)	
	144	Interface, February 1999, pages 176-181; Interface, March 1999, pages 168-173. (Japanese) (3117)	
	145	WOLNIANSKY, P. W. et al., "V-BLAST: An Architecture for Realizing Very High Data Rates Over the Rich-Scattering Wireless Channel," Proc. URSI ISSSE: 295-300, September 1998. (3593)	
	146	WINTERS, J.H. "Optimum Combining in Digital Mobile Radio with Cochannel Interference", IEEE Journal on Selected Areas in Communications, Vol. SAC-2, No. 4, July 1984. (3607)	
	147	YAMAGUCHI, M. et al., "4 GHz 8x8 Switch Matrix for SDMA System," Kokusai Denshin Denwa Co., Ltd., Japan, p. 170-172. (3661)	
	148	ZHANG, Z. et al., "Performance of a Modified Polling Strategy for Broadband Wireless LANs in a Harsh Fading Environment," IEEE GLOBECOM '91 Conference Record, Dec. 1991, Phoenix. (3675)	
	149	ACAMPORA, A.S. et al., "Media Access Protocols for Use with Smart Adaptive Array Antennas to Enable Wireless Multimedia Applications", 9th Tyrrehanian Workshop on Digital Communications, Leric (Italy), Sep. 1997. (3842)	
	150	ZHANG, Z. et al., "Performance of a Modified Polling Strategy for Broadband Wireless Access in a Harsh Fading Environment," Telecommunication Systems, Vol. 1, No. 3, 1993, p. 279-294. (3854)	
	151	GERLACH et al, "Base station transmitter antenna arrays with mobile to base feedback", IEEE, Proceedings of 27th Asilomar Conference on Signals, Systems and Computers, Vol. 2, pp. 1432-6 (3870)	
	152	XR COMMUNICATIONS, LLC, dba VIVATO TECHNOLOGIES v. D-LINK SYSTEMS, INC., et al., CASE NO. 8:17-cv-0596-AG(JCGx), Defendants' Invalidity Contentions Pursuant to Standing Patent Rules 2.5 and 2.6, dated Nov. 10, 2017, 85 pages	
	153	Exhibits A1 – A30	
	154	Exhibits B1 – B27	
	155	Exhibits C1 – C27	

Examiner Signature	Date Considered
*Examiner: Initial if reference considered, whether or not citation is in conformance with MPEP 609. Draw line through citation if not in conformance and not considered. Include copy of this form with next communication to applicant.	

T<sup>1</sup> - Place a check mark in this area when an English language Translation is attached.

# Information Disclosure Statement Transmittal

Docket Number

1640-001.203

Address To  
Commissioner for Patents  
P.O. Box 1450  
Alexandria, Virginia 22313-1450

## In Re Application Of:

Da Silva et al.

Application No. 15/495,539

Filing Date April 24, 2017

Examiner McKie, Gina M.

Art Unit 2631

## Title of Invention

DIRECTED WIRELESS COMMUNICATION

### BASIS FOR FILING (Select 1, 2 or 3 below.)

#### 37 CFR 1.97(b)

- 1)  The Information Disclosure Statement submitted herewith is being filed within three months of the filing of a national application other than a continued prosecution application under 37 CFR 1.53 (d); within three months of the date of entry of the national stage as set forth in 37 CFR 1.491 in an international application; before the mailing of a first Office Action on the merits, or before the mailing of a first Office Action after the filing of a request for continued examination under 37 CFR 1.114.

#### 37 CFR 1.97(c)

- 2)  The Information Disclosure Statement submitted herewith is being filed after the period specified in 37 CFR 1.97(b), but before the mailing date of a Final Action under 37 CFR 1.113, a Notice of Allowance under 37 CFR 1.311, or an Action that otherwise closes prosecution in the application, and is accompanied by one of:

a)  the statement specified in 37 CFR 1.97(e);

OR

b)  the fee set forth in 37 CFR 1.17(p).

#### 37 CFR 1.97(d)

- 3)  The Information Disclosure Statement submitted herewith is being filed after the period specified in 37 CFR 1.97(c), and on or before payment of the issue fee, and is accompanied by the Statement as specified in 37 CFR 1.97(e) and the fee set forth in 37 CFR 1.17(p).

# Information Disclosure Statement Transmittal

Docket Number

1640-001.203

## STATEMENT UNDER 37 CFR 1.97(e) ACCOMPANYING INFORMATION DISCLOSURE STATEMENT

The Information Disclosure Statement submitted herewith is submitted under one of the following conditions, which satisfies the requirement under 37 CFR 1.97(e). (Select 4 or 5 below if applicable.)

- 4)  That each item of information contained in the Information Disclosure Statement was first cited in any communication from a foreign patent office in a counterpart foreign application not more than three months prior to the filing of the Information Disclosure Statement; or
- 5)  That no item of information contained in the Information Disclosure Statement was cited in a communication from a foreign patent office in a counterpart foreign application, and, to the knowledge of the person signing the certification after making reasonable inquiry, no item of information contained in the Information Disclosure Statement was known to any individual designated in 37 CFR 1.56(c) more than three months prior to the filing of the Information Disclosure Statement.

## Remarks (Enter Remarks Below or Attach Document Containing Remarks)

The present application claims priority to US Ser. No. 60/423,660. Two issued patents - US Pat. Nos. 7,062,296 and 7,729,728 - also claim priority to US Ser. No. 60/423,660, but are otherwise unrelated to the present application.

The '296 and '728 patents are currently the subject of litigation in the Central District of California - XR Communications, LLC, dba Vivato Technologies v. D-Link Systems, Inc., et al., 8:17-cv-0596-AG (JCGx).

This IDS presents Invalidity Contentions recently submitted in the lawsuit.

## Fee set forth in 37 CFR 1.17(p):

- No additional fee is required.
- A check in the amount of \_\_\_\_\_ is attached.
- The Director is hereby authorized to charge and credit Deposit Account No. 11-1159 as described below.
- Charge the amount of \_\_\_\_\_
- Credit any overpayment.
- Charge any additional fee required.
- Payment by credit card. Form PTO-2038 is attached.

**WARNING: Information on this form may become public. Credit card information should not be included on this form. Provide credit card information and authorization on PTO-2038.**

<b>Information Disclosure Statement Transmittal</b>	Docket Number
	1640-001.203

Correspondence Address			
Customer Number	22145		
-OR-			
Name			
Address			
City		State	
Country		Postal Code	
Phone Number			
E-mail Address			

**Certificate of Mailing by Express Mail**

I hereby certify that this Transmittal Letter, accompanying documents and fee (if appropriate) are being deposited with the United States Postal Service "Express Mail Post Office to Addressee" service under 37 CFR 1.10 in an envelope addressed to Commissioner for Patents, P.O. Box 1450, Alexandria, Virginia 22313-1450 on the date indicated below:

\_\_\_\_\_

*(Date of Mailing)*

\_\_\_\_\_

*(Typed or Printed Name of Person Mailing Correspondence)*

\_\_\_\_\_

*(Signature of Person Mailing Correspondence)*

\_\_\_\_\_

*("Express Mail" Mailing Label Number)*

**Certificate of Mailing by First Class Mail**

I hereby certify that this Transmittal Letter, accompanying documents and fee (if appropriate) are being deposited with the United States Postal Service with sufficient postage as first class mail in an envelope addressed to Commissioner for Patents, P.O. Box 1450, Alexandria, Virginia 22313-1450 on the date indicated below:

\_\_\_\_\_

*(Date of Mailing)*                      *(Name of Person Mailing Correspondence)*

\_\_\_\_\_

*(Signature of Person Mailing Correspondence)*

**Certificate of Transmission**

I hereby certify that this Transmittal Letter, accompanying documents and fee authorization (if appropriate) is being facsimile transmitted to the United States Patent and Trademark Office on the date indicated below:

\_\_\_\_\_

*(Date of Transmission)*                      *(Name of Person Transmitting Correspondence)*

\_\_\_\_\_

*(Signature of Person Transmitting Correspondence)*

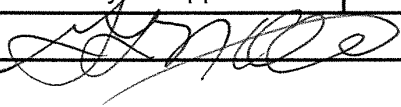
**Signature Instructions**

Select the name of the person who will electronically sign the Transmittal Letter from the drop-down box below.

If a practitioner is not present in the drop-down list, you must close this form and select 'Add Practitioner...' in the Form Manager's Utility menu.

Verify that the signatory information is correct and press the 'eSign' button to electronically sign the submission. If you prefer to sign the form manually, simply do not click the 'eSign' button; just print and manually sign.

Signatory Drop-Down Box   

Name	Glen L. Nuttall		Registration Number	46,188
Signatory Capacity	Attorney for Applicant	E-mail Address		
<input type="button" value="eSign"/>			Date Signed	11/29/2017



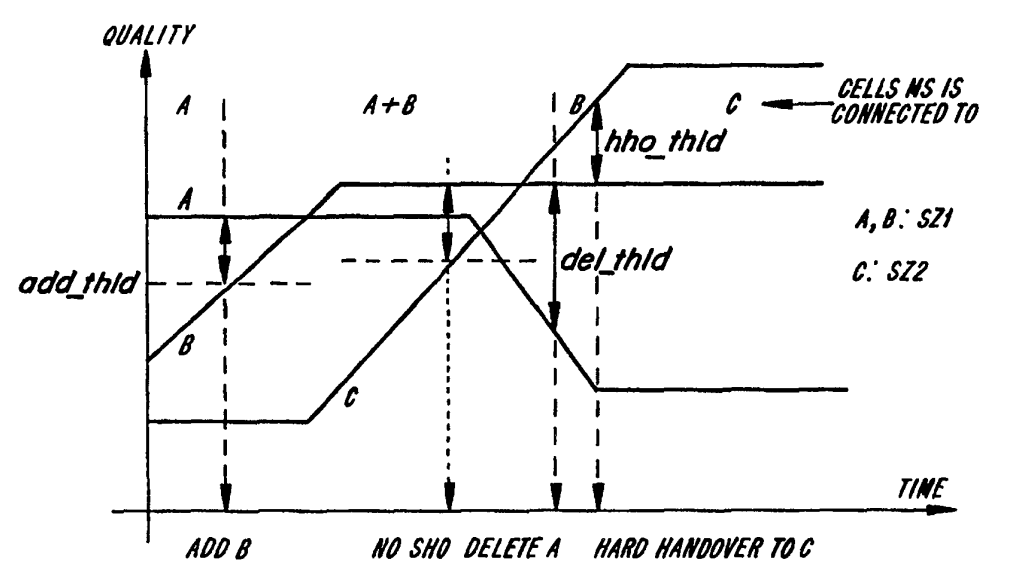


INTERNATIONAL APPLICATION PUBLISHED UNDER THE PATENT COOPERATION TREATY (PCT)

(51) International Patent Classification <sup>7</sup> : <b>H04Q 7/38</b>	<b>A1</b>	(11) International Publication Number: <b>WO 00/38455</b>
		(43) International Publication Date: 29 June 2000 (29.06.00)

<p>(21) International Application Number: PCT/EP99/10083</p> <p>(22) International Filing Date: 17 December 1999 (17.12.99)</p> <p>(30) Priority Data: PCT/IB98/02071 18 December 1998 (18.12.98) IB 09/461,030 15 December 1999 (15.12.99) US</p> <p>(71) Applicant: TELEFONAKTIEBOLAGET LM ERICSSON (publ) [SE/SE]; S-126 25 Stockholm (SE).</p> <p>(72) Inventors: JETZEK, Ulrich; Gerngrosstrasse 72, D-90409 Nürnberg (DE). BLOMBERG, Petter; Agatan 20, S-172 62 Sundbyberg (SE). JOHANSSON, Lars, B.; Torpparegatan 37, S-583 32 Linköping (SE). JONSSON, Sture; Sandviksgatan 78B, S-972 34 Lulea (SE). BUTOVITSCH, Peter; Domusu Yoyog-Uehara 3201, 3-17-15, Uehara, Shibuya-ku, Tokyo 150-0000 (JP).</p> <p>(74) Agent: MOHSLER, Gabriele; Ericsson Eurolab Deutschland GmbH, Ericsson Allee 1, D-52134 Herzogenrath (DE).</p>	<p>(81) Designated States: AE, AL, AM, AT, AU, AZ, BA, BB, BG, BR, BY, CA, CH, CN, CR, CU, CZ, DE, DK, DM, EE, ES, FI, GB, GD, GE, GH, GM, HR, HU, ID, IL, IN, IS, JP, KE, KG, KP, KR, KZ, LC, LK, LR, LS, LT, LU, LV, MA, MD, MG, MK, MN, MW, MX, NO, NZ, PL, PT, RO, RU, SD, SE, SG, SI, SK, SL, TJ, TM, TR, TT, UA, UG, UZ, VN, YU, ZA, ZW, ARIPO patent (GH, GM, KE, LS, MW, SD, SL, SZ, TZ, UG, ZW), Eurasian patent (AM, AZ, BY, KG, KZ, MD, RU, TJ, TM), European patent (AT, BE, CH, CY, DE, DK, ES, FI, FR, GB, GR, IE, IT, LU, MC, NL, PT, SE), OAPI patent (BF, BJ, CF, CG, CI, CM, GA, GN, GW, ML, MR, NE, SN, TD, TG).</p> <p><b>Published</b> <i>With international search report. Before the expiration of the time limit for amending the claims and to be republished in the event of the receipt of amendments.</i></p>
--	---

(54) Title: METHODS AND SYSTEMS FOR CONTROLLING HARD AND SOFT HANDOFFS IN RADIO COMMUNICATION SYSTEMS



(57) Abstract

A method, controller and system for controlling handoffs in radio communication systems using a softzone concept are described. Soft handoff is permitted between members of a particular softzone, but not between members of different softzones. Hard handoff is permitted between members of different softzones, but not between members of the same softzone.

**FOR THE PURPOSES OF INFORMATION ONLY**

Codes used to identify States party to the PCT on the front pages of pamphlets publishing international applications under the PCT.

<b>AL</b>	Albania	<b>ES</b>	Spain	<b>LS</b>	Lesotho	<b>SI</b>	Slovenia
<b>AM</b>	Armenia	<b>FI</b>	Finland	<b>LT</b>	Lithuania	<b>SK</b>	Slovakia
<b>AT</b>	Austria	<b>FR</b>	France	<b>LU</b>	Luxembourg	<b>SN</b>	Senegal
<b>AU</b>	Australia	<b>GA</b>	Gabon	<b>LV</b>	Latvia	<b>SZ</b>	Swaziland
<b>AZ</b>	Azerbaijan	<b>GB</b>	United Kingdom	<b>MC</b>	Monaco	<b>TD</b>	Chad
<b>BA</b>	Bosnia and Herzegovina	<b>GE</b>	Georgia	<b>MD</b>	Republic of Moldova	<b>TG</b>	Togo
<b>BB</b>	Barbados	<b>GH</b>	Ghana	<b>MG</b>	Madagascar	<b>TJ</b>	Tajikistan
<b>BE</b>	Belgium	<b>GN</b>	Guinea	<b>MK</b>	The former Yugoslav Republic of Macedonia	<b>TM</b>	Turkmenistan
<b>BF</b>	Burkina Faso	<b>GR</b>	Greece	<b>ML</b>	Mali	<b>TR</b>	Turkey
<b>BG</b>	Bulgaria	<b>HU</b>	Hungary	<b>MN</b>	Mongolia	<b>TT</b>	Trinidad and Tobago
<b>BJ</b>	Benin	<b>IE</b>	Ireland	<b>MR</b>	Mauritania	<b>UA</b>	Ukraine
<b>BR</b>	Brazil	<b>IL</b>	Israel	<b>MW</b>	Malawi	<b>UG</b>	Uganda
<b>BY</b>	Belarus	<b>IS</b>	Iceland	<b>MX</b>	Mexico	<b>US</b>	United States of America
<b>CA</b>	Canada	<b>IT</b>	Italy	<b>NE</b>	Niger	<b>UZ</b>	Uzbekistan
<b>CF</b>	Central African Republic	<b>JP</b>	Japan	<b>NL</b>	Netherlands	<b>VN</b>	Viet Nam
<b>CG</b>	Congo	<b>KE</b>	Kenya	<b>NO</b>	Norway	<b>YU</b>	Yugoslavia
<b>CH</b>	Switzerland	<b>KG</b>	Kyrgyzstan	<b>NZ</b>	New Zealand	<b>ZW</b>	Zimbabwe
<b>CI</b>	Côte d'Ivoire	<b>KP</b>	Democratic People's Republic of Korea	<b>PL</b>	Poland		
<b>CM</b>	Cameroon	<b>KR</b>	Republic of Korea	<b>PT</b>	Portugal		
<b>CN</b>	China	<b>KZ</b>	Kazakstan	<b>RO</b>	Romania		
<b>CU</b>	Cuba	<b>LC</b>	Saint Lucia	<b>RU</b>	Russian Federation		
<b>CZ</b>	Czech Republic	<b>LI</b>	Liechtenstein	<b>SD</b>	Sudan		
<b>DE</b>	Germany	<b>LK</b>	Sri Lanka	<b>SE</b>	Sweden		
<b>DK</b>	Denmark	<b>LR</b>	Liberia	<b>SG</b>	Singapore		
<b>EE</b>	Estonia						

**METHODS AND SYSTEMS FOR CONTROLLING HARD AND  
SOFT HANDOFFS IN RADIO COMMUNICATION SYSTEMS**

**BACKGROUND**

5           The present invention relates generally to methods and systems for radiocommunications and, more particularly, to such systems in which a connection can be handed over from one channel or base station to another.

          The cellular telephone industry has made phenomenal strides in commercial operations in the United States as well as the rest of the world. Growth in major  
10 metropolitan areas has far exceeded expectations and is rapidly outstripping system capacity. If this trend continues, the effects of this industry's growth will soon reach even the smallest markets. Innovative solutions are required to meet these increasing capacity needs as well as maintain high quality service and avoid rising prices.

15           In cellular systems, the capability is typically provided to transfer handling of a connection between, for example, a mobile station and a base station to another base station, as the mobile station changes its position and so moves out of the coverage area of one base station and into the coverage area of another base station. This type of handoff is commonly referred to as an "intercell" handoff as the  
20 coverage areas associated with base stations are commonly referred to as "cells". Depending upon the quality of the current channel, it may also be desirable to transfer a connection from one channel of the base station to another channel supported by the same base station, which handoffs are commonly referred to as "intracell" handoffs.

So-called "hard" handoffs refer to handoffs which are performed wherein there is no overlap in time between transmissions received from an original, serving base station and transmissions received from a new, target base station. As shown in Figure 1(a), during hard handoff, the mobile station (MS) typically first breaks its  
5 connection to its original base station (BTS1) and then establishes a connection to its new base station (BTS2).

By way of contrast, "soft" handoffs refer to handoffs wherein, for some period of time, a mobile station receives substantially the same information from two (or more) transmission sources. An exemplary soft handoff scenario is  
10 illustrated in Figure 1(b). Therein, before starting soft handoff, the MS is connected to BTS1. During the soft handoff, the MS establishes a connection to BTS2 without dropping the connection to BTS1. Each base station which is concurrently communicating with a particular mobile station may be referred to as a member of that mobile station's "active set". At some time after the connection to BTS2 is set  
15 up, the connection to BTS1 will be released which is the termination of the soft handover procedure. The overlapping transmissions from BTS1 and BTS2 permit the mobile station to smoothly switch from receiving information from its original, serving base station to receiving information from its new, target base station. During soft handoff, the mobile station may also take advantage of the fact that it is  
20 receiving substantially the same information from two sources to improve its received signal quality by performing diversity selection/combining of the two received signals.

For the sake of simplicity, the foregoing examples of the hard and soft handoff were described in the context of base stations employing omnidirectional  
25 antennas, i.e., wherein each base station transmits signals which propagate in a

substantially circular direction, i.e., 360 degrees. However, as will be appreciated by those skilled in the art, other antenna structures and transmission techniques may also be employed in radiocommunication systems. For example, a cell can be subdivided into several sectors, e.g., into three sectors where each sector covers a

5 120 degree angle as shown in Figure 2. Alternatively, the system or cell may employ an array antenna structure as shown in Figure 3. Therein, an exemplary radio communication system 200 includes a radio base station 220 employing a fixed-beam phased array (not shown). The phased array generates a plurality of fixed narrow beams ( $B_1, B_2, B_3, B_4$ , etc.) which radially extend from the base station

10 220, at least one of which ( $B_1$ ) is used to communicate with MS 210. Preferably, the beams overlap to create a contiguous coverage area to service a radio communication cell. Although not shown, the phased array can actually consist of three phased array sector antennas.

Of course, the principles described above with respect to hard and soft

15 handoff for omnidirectional antennas in Figures 1(a) and 1(b) can be directly mapped to other systems which employ sectorized and/or array antennas. In these latter types of systems, hard and soft handoffs can be performed between sectors or beams of the same base station as well as between sectors or beams associated with different base stations.

20 Both types of handoff have their drawbacks and advantages. On the one hand, soft handoff provides a robust mechanism for changing the connection from one base station to another. However, since the mobile station is connected to more than one base station during soft handoff, soft handoff requires more system resources than hard handoff. An advantage of hard handoff, therefore, is a reduced

need for system resources, while its drawback is a higher probability of dropped calls when compared to soft handoff.

Both hard and soft handoffs are employed in some radiocommunication systems. For example, Figure 4 illustrates a system described in WO 96/02117, wherein soft and hard handoff are applied sequentially. Therein, a system containing two base station controllers, BSC1 and BSC2, is shown. BSC1 controls base stations BTS11, BTS12 and BTS13, while BSC2 controls base stations BTS21, BTS22, and BTS23. The area that is served by all of the base stations coupled to a BSC is called a "BSC area".

10 Assume for this example, that the mobile station (MS) moves from cell A served by the base station BTS12 to cell B, which is at the border between two BSC areas. Cell B is served by two overlapping base stations, BTS11 and BTS21. BTS11 is coupled to controller BSC1, and BTS21 is coupled to base station controller BSC2. As the MS moves to cell B, it carries out a soft handoff controlled by BSC1 to a traffic channel of base station BTS11.

15 Assume further that the MS continues onward toward cell C and finally enters into its area of radiocommunication coverage. The base station BTS22, serving cell C, is under the control of BSC2. Before it is possible to activate the base station BTS22 for the handoff, the call control must first be switched to base station controller BSC2 from the previous controller BSC1. This is accomplished by performing a hard handoff. The MS performs a hard handoff from the base station BTS11 to the base station BTS21, and consequently, the base station controller change from BSC1 to BSC2 takes place. Finally, a soft handoff from BTS21 to BTS22 is performed.

However, these techniques described in WO 96/02117 do not provide a mechanism for controlling the use of either soft or hard handoff. Instead, these techniques are simply provided as an intended mechanism for reducing interference and signaling overhead associated with the handoff of a mobile area from a service area under the control of a first BSC to a service area under the control of a second BSC. Thus, these techniques do not provide any solution for controlling the usage of soft and hard handoff between cells *per se*.

According to European Patent Application 817 517 A1, as illustrated in Figure 5, a technique is presented for determining an appropriate type of handoff for a mobile station. In the Figure, the received perch channel (i.e., a type of broadcast control channel) level is shown for the cell where the MS resides initially (solid line) as well as for a neighboring cell (dashed line). The received levels are given with respect to the position of the mobile station.

According to EP 817 517 A1, the handoff type judgement method for a CDMA mobile communication system provides different types of handoff with different handoff start conditions. A type of handoff for which a handoff start condition is weakest, among the available types of handoff at a mobile station, is evaluated first. It is determined whether the handoff start condition for this type of handoff is satisfied or not at the mobile station. Each base station is notified for carrying out that type of handoff when the handoff start condition for that handoff is satisfied.

However, the techniques described in EP 817 517 A1 require that the mobile station be informed for each sector regarding which type of handoff is available. Hence out of a number of possible cells/sectors suitable for handoff with, possibly, different available handoff types, the mobile station first has to select all

cells/sectors that are available for the handoff type with weakest start condition. In a second step, a judgement among all of these cells/sectors will be performed. Thus, these techniques suffer from the drawbacks of having a two step procedure that requires intense signalling between the network (i.e., the base station) and the mobile station and that it is also quite complex to implement.

Accordingly, there is a need to develop enhanced techniques to determine when a handoff is appropriate, and which type of handoff is appropriate, to efficiently utilize system resources under different operating conditions.

10

#### SUMMARY

These, and other, problems, drawbacks, and limitations of conventional handoff techniques, are overcome according to the present invention in which a mechanism is provided for controlling the usage of soft and hard handoffs. According to exemplary embodiments of the present invention, methods and systems determine which handoff type is preferred at a specific location under current radio conditions. Another object of the present invention is to control hard and soft handoff while at the same time minimizing the overhead signalling between the network and the mobile station. Yet another object is to provide control methods and systems which are applicable to radiocommunication systems that use more than one frequency band to support communications in a cell/sector at the same time.

These, and other objects of the present invention are attained by a method for controlling handoff of a mobile station to a target transmission source in a radiocommunication system which comprises the steps of:

grouping a number of transmission sources into a group;



- assigning, to an active set associated with said mobile station, at least one transmission source from said group;
- selecting a first type of handoff to occur to at least one target transmission source if said at least one target transmission source is within said group; and
- 5 selecting a second type of handoff to occur to said at least one target transmission source if said first type of handoff is not selected.

In the method, a grouping of transmission sources (e.g., cells, sectors, base stations, beams or combinations thereof) is performed into groups which are denoted  
10 as softzones. Each softzone has its own softzone identity. Softzone identities can be reused for sectors which are not too close to each other. All members in the active set have the same softzone identity. However, each transmission source may belong to multiple softzones, i.e. it is possible that a transmission source is assigned to different groups.

15 Softzone handoff mechanisms according to the present invention provide a number of benefits. For example, the overhead signalling between the mobile station and the network associated with controlling handoff type selection will be reduced as compared, for example, to the techniques described in EP 817 517 A1. This is due to the fact that cells/sectors are grouped into different softzones instead  
20 of treating each cell/sector separately for the purpose of determining which type of handoff, if any, is appropriate. Moreover, these techniques provide a one-step procedure which permits great flexibility in the number of different handoff types that can be used.

Cell planners can use the softzone concepts described herein as a tool to take  
25 into account that between certain cells hard handoff might be more reasonable while

between other cells a soft handover might be most suitable. Moreover, the grouping of transmission sources into particular softzones need not be static, e.g., a network operator may adjust softzone assignments based on changes to system structure (e.g., cell addition or cell splitting), changing load conditions, etc. Softzones can also be  
5 automatically regrouped by way of a dynamic regrouping algorithm, e.g., based on current network resources, air interface resources and loading patterns.

In a preferable embodiment of the method said first type of handoff is a soft handoff. In a soft handoff, at least one transmission source of the active set and at least one  
10 target transmission source in the handoff transmit substantially the same information to a mobile station at substantially the same time. The second type of handoff is preferably a hard handoff wherein a mobile station ceases receiving transmissions from one transmission source prior to receiving transmissions from a target transmission source. In an exemplary embodiment, soft handoffs may only be  
15 performed with transmission sources having the same softzone id as current members of the active set. Likewise, hard handoffs may only be performed to transmission sources having a different softzone id than current members of the active set.

20 Examples of suitable transmission sources include a cell, a base station, a frequency band, a beam associated with an antenna array and a sector. Preferably, the membership of transmission sources to a group can be readjusted.

A base station operating in a radiocommunication system can support  
25 communication on two or more different frequency bands. In this case, a suitable

choice of the groups is that transmission sources in a first frequency band supported by said base station are assigned to one group.

5 The step of selecting a type of handoff preferably comprises the step of measuring a quality level associated with transmission sources a group. The measured quality levels can then be evaluated in conjunction with at least one threshold. The membership in the active set of the mobile station can in this way be based on a result of the evaluating step. A preferable threshold can be adjusted. It can vary, for example, as a function of a quality level associated with a member of said active set.

10

Preferable quantities for the measurement of the quality level are for example the downlink signal-to-interference ratio, downlink received signal strength, downlink pathloss or downlink pathloss plus uplink interference. Combinations of different quantities can be used.

15

Preferably, group identifiers of transmission sources are transmitted to the mobile station.

20 A controller for controlling handoff of a mobile station to a target transmission source in a radiocommunication system comprises, according to the invention, preferably a processor selecting a soft handoff of a connection from at least one first transmission source, having a first group identification assigned thereto, to at least one second transmission source, having a second group identification assigned thereto, when said first and second group identifications are the same. A

25 transmission source can include for example one or more beams of an antenna array

or one or more sectors associated with one or more base stations. A hard handoff of said connection from one of the first transmission sources to one of the second transmission sources is selected when said first and second group identifications are different. It is possible that a transmission source is assigned to both said first and second groups.

In a preferable embodiment, the transmission sources comprise transceivers disposed within a same base station but which support communications on different frequency bands.

In a preferable embodiment, a processor in the controller can reassign a transmission source from a first group identification to another group identification. The processor can be identical to or different from the processor selecting the transmission device.

The controller can be disposed in a switch of the communication network. Switches are nodes in the network of the communication system for controlling connections like for example a BSC (base station controller) or an MSC (mobile switching center) according to GSM or UMTS specifications or an RNC (radio network controller). The controller can also be disposed in a mobile station.

A preferable radiocommunication system according to the invention comprises at least one first transmission source, having a first group identification assigned thereto and supporting a connection with a mobile station. A second transmission source has a second group identification assigned thereto. A processor associated

with a network controller, e.g. a switch, for controlling operations of the transmission sources and said mobile station selects a soft handoff of the connection from one of the first transmission sources to one of the second transmission sources when the group identifications are the same. When said first and second group  
5 identifications are different, a hard handoff of said connection from a first transmission source to a second transmission source is selected.

10

#### **BRIEF DESCRIPTION OF THE DRAWINGS**

The foregoing, and other, objects, features and advantages of the present invention will be more readily understood upon reading the following detailed description in conjunction with the drawings in which:

15 Figure 1(a) is an illustration of hard handoff;  
Figure 1(b) is an illustration of soft handoff;  
Figure 2 depicts a base station employing sector antennas;  
Figure 3 shows a base station employing an array antenna;  
Figure 4 is an illustration of a conventional technique for performing  
20 sequential hard and soft handoffs to handoff a connection involving two base station controllers;  
Figure 5 depicts another conventional technique for controlling different types of handoff;  
Figure 6 is a block diagram showing various functional blocks of an  
25 exemplary mobile station;

Figure 7 is a graph illustrating various handoff algorithm conditions for adding, deleting and replacing sectors;

Figure 8 shows three cells grouped into two softzones used to describe exemplary embodiments of the present invention; and

5 Figure 9 is a graph of measured quality versus time used to explain handoff techniques according to exemplary embodiments of the present invention.

#### **DETAILED DESCRIPTION**

In the following description, for purposes of explanation and not limitation,  
10 specific details are set forth, such as particular circuits, circuit components, techniques, etc. in order to provide a thorough understanding of the invention. However it will be apparent to one skilled in the art that the present invention may be practiced in other embodiments that depart from these specific details. In other instances, detailed descriptions of well-known methods, devices, and circuits are  
15 omitted so as not to obscure the description of the present invention with unnecessary details. For example, although not described in detail herein, the present invention is applicable to radiocommunication systems which employ any type of access methodology, e.g., Frequency Division Multiple Access (FDMA), Time Division Multiple Access (TDMA), Code Division Multiple Access (CDMA),  
20 or any hybrid thereof.

Moreover, this specification describes techniques that are applicable to different types of handoffs. However, these techniques can be applied to handoffs from or to any transmission source, e.g., a cell, a base station, a sector, a beam, a transceiver, etc. Accordingly, although the term "cell" is used primarily herein to  
25 illustrate how handoff mechanisms according to the present invention operate, it will

be appreciated by those skilled in the art that these techniques apply equally to any type of transmission source.

Prior to describing the details of the present invention, an example of the construction of a mobile station which can operate to perform the signal quality measurements described above is illustrated in Figure 6. This block diagram has  
5 been simplified to illustrate only those components relevant to the measurement of downlink signal strength, however those skilled in the art will be well aware of the other major functional blocks associated with mobile stations. In Figure 6, incoming radio signals are received by transmitter/receiver TRX 500. The timing is  
10 synchronized to the received symbol sequence by microprocessor controller 530. The strength of the received signals are measured by a signal strength measuring part 520, the value of which is then passed to microprocessor controller 530. The bit error rate (BER) of the received signal can also be determined as an indication of received signal quality as reflected by block 540. This measurement of received  
15 signal quality is particularly relevant in determining when an intracell handoff is desirable. Of course, the present invention is applicable to systems which use any type of quality measurement parameter, e.g., signal-to-interference ratio, received signal strength or pathloss. The mobile station will also have input/output devices,  
20 such as a keyboard and display 535, as well as a microphone and speaker unit (not shown), which enables information to be exchanged between the mobile station and the base station.

When the mobile station receives a list of channel numbers, codes or other channel identifying information in a measurement command, it will measure the received signal quality associated with each of those channels. Once the mobile  
25 station has made the requested measurements, at least two different evaluation

techniques can be employed. First, if network evaluated handoff (NEHO) is employed, then the mobile station will report the measurements to the system which will then evaluate the various sectors using a handoff algorithm. Alternatively, if mobile evaluated handover (MEHO) is employed, then the mobile station itself will evaluate the various sectors.

An example is provided in Figure 7 to illustrate how the active set may change over time based on applying a handoff algorithm to these measurements. Taking as a given that there are four sectors (A,B,C,D) of interest in the handoff scenario of Figure 7, it is initially assumed that only sector A belongs to the active set. The measurement set in this example contains all sectors of the active set and all the neighbors of the active set, in this example A, B and C. Generally speaking, the measurement set contains all of the transmission sources for which the mobile station makes measurements. The measurement set typically includes all members of the active set, as well as transmission sources which are neighbors of the transmission sources in the active set. The measurement set is also typically defined by the network and periodically transmitted to the mobile station.

This exemplary handoff algorithm dictates that different handoff actions will be triggered according to the conditions stated below:

1. Add a sector: A sector X is added to the current active set if its quality  $Q_x$  meets the following condition:

$$Q_x > Q_{\text{best}} - \text{add\_th}$$

where  $Q_{\text{best}}$  represents the quality of the sector with the best quality in the Active Set and  $\text{add\_th}$  is a threshold value. For example, as shown in Figure 7, sector B is added to the active set at the time instant marked 'Add B' since the



difference between its quality level and the quality level received from sector A falls below add\_th. Note that after time 'Add B', sector D is added to the measurement set because it is a neighbor to sector B.

- 5           2.       Delete a sector: A sector X is deleted from the current active set if its quality  $Q_x$  meets the following condition:

$$Q_x < Q_{\text{best}} - \text{delete\_th}$$

where delete\_th represents the deletion threshold. An example of this condition occurring may be found at time instant marked 'Remove C' in Figure 7, wherein  
10       sector C is removed from the active set since the difference between its received quality level and that of sector B exceeds delete\_th.

3.       Replace a sector: The maximum number of cells allowed in the active set is limited. Once this maximum number is reached, the active set is said to  
15       be full. A sector X replaces the sector with the worst quality in the active set if the active set is full and the following condition holds:

$$Q_x > Q_{\text{worst}} + \text{replace\_th}$$

where replace\_th represents the threshold used for sector replacement. Provided that the maximum number of sectors in the active set is two in Figure 7, sector C should  
20       replace sector A at time instant marked 'Replace A with C' in Figure 7.

4.       Perform a hard handover: A hard handover from the current active set to a new sector is carried out if the quality  $Q_x$  of sector X fulfills the following condition:

25            $Q_x > Q_{\text{best}} + \text{hho\_th}$

where hho\_th represents the threshold used for hard handover, i.e., all connections of the current active set will be removed and a new connection to sector X will be set up. This is, for example, the case at the time instant marked 'hard handover to D' in Figure 7.

5           The actions described in this handoff algorithm to add, delete or replace a sector occur as soft handoffs in this example, unless the hard handoff threshold is exceeded in which case hard handoff takes precedence. However, according to exemplary embodiments of the present invention, additional control mechanisms are established to determine whether a soft or hard handoff is appropriate. More  
10 specifically, the present invention adopts an overlay mechanism referred to herein as a "softzone". The softzone is a group of cells, base stations or other transmission sources (e.g., sectors, beams, etc.) which can be identified by, for example, a softzone identification number (softzone id). Soft handoffs are then permitted only between members within the group having the same softzone id. The active set has  
15 a softzone identity which is referred to herein as the "active softzone identity". The softzone ids will be distributed from the network to the mobile station on either common or dedicated channels. Thus, the handoff rules described above with respect to Figure 7 are modified according to this exemplary embodiment such that:

- 20           1.       When the quality of a measured cell (base station, transmission source, beam, sector, etc.) exceeds the value  $Q_{best} - add\_th$  (the addition threshold), and the measured cell has a softzone identity which is identical to the active softzone identity, then the cell will be added to the active set in a soft handoff action. If the measured cell  
25 has a different softzone identity than the active set cells, the measured

cell will not be added to the active set, even though the quality of the measured cell exceeds  $Q_{\text{best}} - \text{add\_th}$ .

- 5           2.       When the quality of a measured cell (base station, transmission source, beam, sector, etc.) drops below the value of  $Q_{\text{best}} - \text{delete\_th}$  (the deletion threshold), and the measured cell belongs to the current active set, then the cell will be deleted from the current active set as part of a soft handoff operation.
  
- 10          3.       When the quality of a measured cell (base station, transmission source, beam, sector, etc.) exceeds the value of  $Q_{\text{best}} + \text{hho\_th}$  (the hard handover threshold), and the measured cell does not have a softzone identity which is identical to the active softzone identity, then a hard handoff will be performed to the measured cell. If the  
15           measured cell has the same softzone identity as the active set cells, no handoff action will be taken.
  
- 20          4.       When the quality of a measured cell (base station, transmission source, beam, sector, etc.) exceeds the value of  $Q_{\text{worst}} + \text{rpl\_th}$  (the replacement threshold), and the measured cell has a softzone identity which is identical to the active softzone identity, then the measured  
25           cell will replace the active set cell with the worst quality.

Of course, the softzone identities must be known in the mobile station (in the case of  
25   MEHO) or in the network (in the case of NEHO). Thus, in the former case, the

softzone identities will be transmitted to the mobile station beforehand. The values of the various handoff thresholds described herein may be fixed or may be variable with respect to, for example, the quality level of the best cell (base station, transmission source, beam, sector, etc.) in the active set.

5           An illustrative example is provided in Figures 8 and 9 to further explain softzone handoff concepts according to exemplary embodiments of the present invention. In Figure 8, three cells (A, B and C) are depicted that belong to two different softzones SZ1 and SZ2 and, therefore have different softzone ids. Initially, for this example, assume that a mobile station (not shown in Figure 8) is only  
10           connected to cell A. When the quality of cell B satisfies the condition to add a cell, i.e., at time instant "add B" in Figure 9, a connection to cell B is added, since cells A and B both belong to softzone SZ1. Although the quality of cell C exceeds the addition threshold as well, i.e., at time instant "no SHO" in Figure 9, cell C is not added by way of soft handoff since cell C has a different softzone identity than the  
15           current members of the active set A and B.

          After cell A has been deleted from the active set, i.e., at time instant "delete A" in Figure 9, the quality of cell C exceeds the hard handoff threshold. Thus a hard handoff will be performed that removes cell B from the active set and adds cell C thereto at time instant "hard handover to C" in Figure 9, since cell C belongs to  
20           softzone SZ2, while cell B belongs to softzone SZ1. Of course, if cells B and C had belonged to the same softzone, then no action would have been taken at time instant "hard handover to C" in Figure 9 because in this case cell c would have been added to the active set at time instant "no sho".

          Softzone handoff mechanisms according to the present invention provide a  
25           number of benefits. For example, the overhead signalling between the mobile

station and the network associated with controlling handoff type selection will be reduced as compared, for example, to the techniques described in EP 817 517 A1. This is due to the fact that cells/sectors are grouped into different softzones instead of treating each cell/sector separately for the purpose of determining which type of handoff, if any, is appropriate. Moreover, these techniques provide a one-step procedure which permits great flexibility in the number of different handoff types that can be used.

Cell planners can use the softzone concepts described herein as a tool to take into account that between certain cells hard handoff might be more reasonable while between other cells a soft handover might be most suitable. In rural areas, for example, line of sight links between mobile stations and base stations are rather frequent. Typically, even in case of hard handoff, a reliable handoff will be performed. On the other hand, in urban areas, line of sight links are rather rare. Furthermore, connection quality may be poor due to shadowing effects. For these reasons, a call is likely to get dropped during a hard handoff, thus creating a preference for soft handoff under these circumstances. In such a scenario, one softzone identity could be assigned to several adjacent urban cells while several different softzone identities could be assigned to rural cells.

Moreover, the grouping of transmission sources into particular softzones need not be static, e.g., a network operator may adjust softzone assignments based on changes to system structure (e.g., cell addition or cell splitting), changing load conditions, etc. Softzones can also be automatically regrouped by way of a dynamic regrouping algorithm, e.g., based on current network resources, air interface resources and loading patterns.

Further, it is anticipated that system capacity will most likely be increased by implementation of the present invention, since the present invention offers the possibility to control soft and hard handoff whereby efficient use of system resources is promoted.

5           The above-described exemplary embodiments are intended to be illustrative in all respects, rather than restrictive, of the present invention. For example, although the preceding exemplary embodiments do not reference multiple frequency bands, it will be apparent to those skilled in the art that the present invention is applicable to systems employing multiple frequency bands for communication and, 10 therefore, to either intrafrequency or interfrequency band handoff. Moreover, the same or different softzone ids may be provided for different frequency bands used by the same base station to provide communication services. Of course, for mobile stations having only a single receiver, i.e., which can only tune to a single frequency band at a given time, it would then be preferable to provide different softzone ids to 15 different frequency bands employed by a particular base station, i.e., to force hard handoffs rather than soft handoffs therebetween.

Thus the present invention is capable of many variations in detailed implementation that can be derived from the description contained herein by a person skilled in the art. All such variations and modifications are considered to be 20 within the scope and spirit of the present invention as defined by the following claims.

**CLAIMS**

1. A method for controlling handoff of a mobile station to a target transmission source in a radiocommunication system comprising the steps of:  
5       grouping a number of transmission sources into a group;  
      assigning, to an active set associated with said mobile station, at least one transmission source from said group;  
      selecting a first type of handoff to occur to at least one target transmission source if said at least one target transmission source is within said group; and  
10       selecting a second type of handoff to occur to said at least one target transmission source if said first type of handoff is not selected.
  
2. Method according to claim 1, wherein said first type of handoff is soft handoff wherein said at least one transmission source of said active set and said at least  
15       one target transmission source transmit substantially the same information to said mobile station at substantially the same time.
  
3. Method according to claim 1 or 2, wherein said second type of handoff is hard handoff wherein said mobile station ceases receiving transmissions from said at  
20       least one transmission source prior to receiving transmissions from said at least one target transmission source.
  
4. Method according to any preceding claim, wherein said transmission sources  
25       include at least one of: a cell, a base station, a frequency band, a beam associated with an antenna array and a sector.

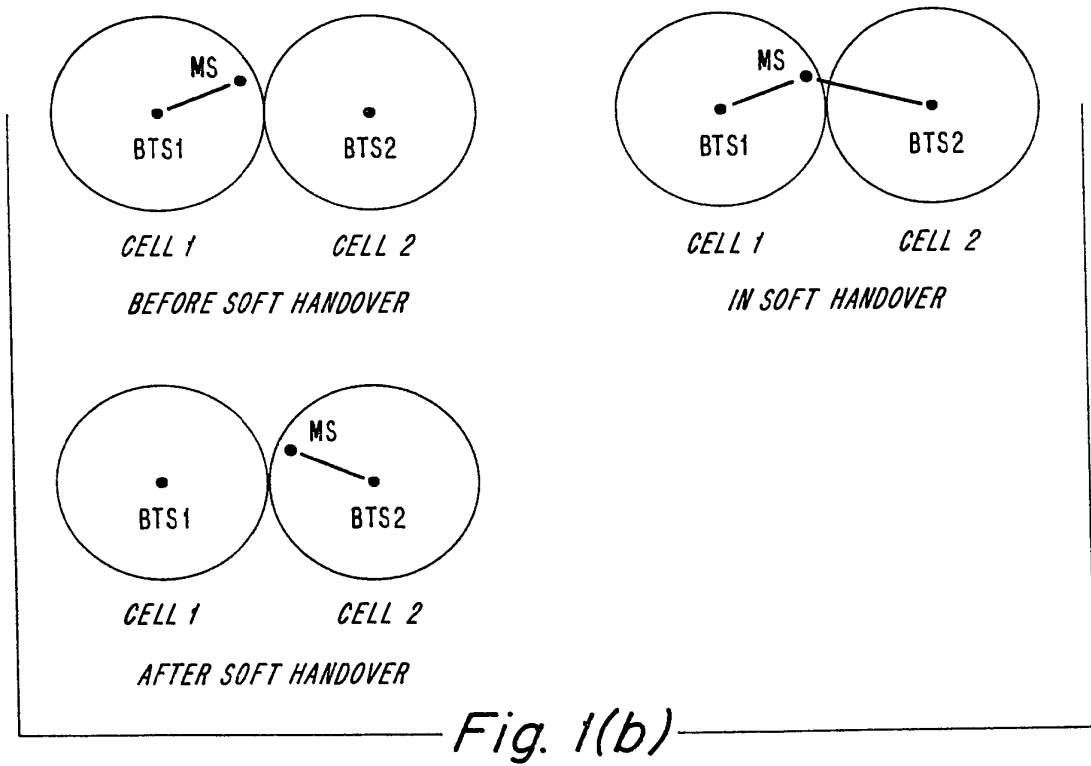
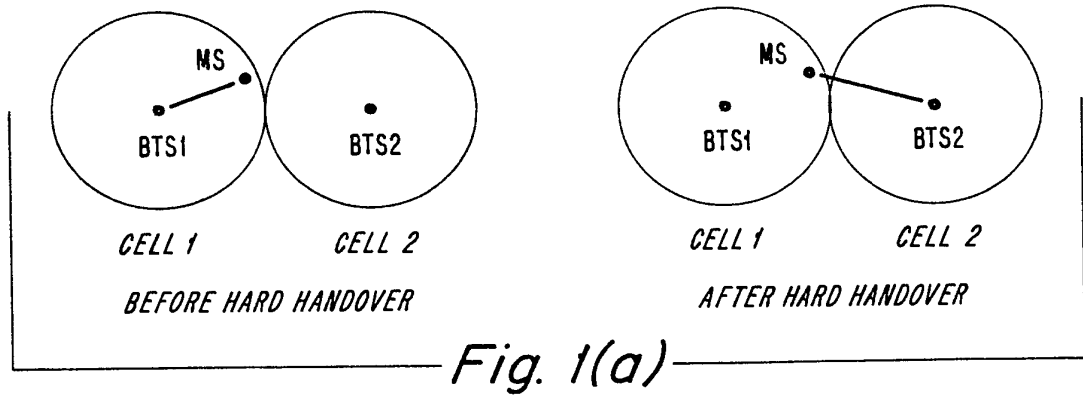
5. Method according to any preceding claim, further comprising the step of adjusting membership of transmission sources of said group.
- 5 6. Method according to any preceding claim, wherein a base station operating in said radiocommunication system supports communication on at least two different frequency bands and wherein said step of grouping further comprises: grouping a first frequency band associated with said base station in said group.
- 10 7. Method according to any preceding claim, wherein said step of selecting a first type of handoff further comprises the steps of:  
measuring a quality level associated with transmission sources in said group;  
evaluating said measured quality levels in conjunction with at least one  
threshold; and  
15 adjusting membership in said active set based on a result of said evaluating step.
8. Method according to claim 7, wherein said at least one threshold is variable.
9. Method according to claim 7 or 8, wherein said quality level is one of downlink  
20 signal-to-interference ratio, downlink received signal strength, downlink pathloss and downlink pathloss plus uplink interference.
10. Method according to claim 8 or 9, wherein said at least one threshold varies as a  
function of a quality level associated with a member of said active set.

25



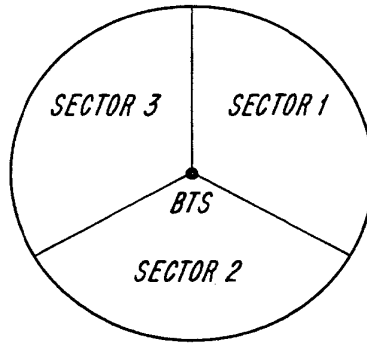
11. Method according to any preceding claim further comprising the step of distributing group identifiers of transmission sources to said mobile station.
12. Method according to any preceding claim, wherein at least one transmission  
5 source is assigned to different groups.
13. A controller for controlling handoff of a mobile station to a target transmission source in a radiocommunication system with a processor for:
  - selecting a soft handoff of a connection from at least one first transmission  
10 source, having a first group identification assigned thereto, to at least one second transmission source, having a second group identification assigned thereto, when said first and second group identifications are the same; and
  - selecting a hard handoff of said connection from said at least one first  
15 transmission source to said at least one second transmission source when said first and second group identifications are different.
14. Controller according to claim 13, wherein said at least one first and said at least  
one second transmission sources are transceivers disposed within a same base  
station but which support communications on different frequency bands.  
20
15. Controller according to any of the claims 13 or 14, wherein a processor can  
reassign said at least one first transmission source from said first group  
identification to another group identification.

16. Controller according to any of the claims 13 to 15, wherein the controller is disposed in a mobile station.
17. Controller according to any of the claims 13 to 15, wherein said controller is disposed in a switch.
18. A radiocommunication system comprising:  
at least one first transmission source, having a first group identification assigned thereto and supporting a connection with a mobile station;  
at least one second transmission source, having a second group identification assigned thereto;  
a network controller for controlling operations of said at least one first and said at least one second transmission sources; and  
a processor, associated with one of said network controller and said mobile station for:  
- selecting a soft handoff of said connection from said at least one first transmission source to said at least one second transmission source when said first and second group identifications are the same; and  
- selecting a hard handoff of said connection from said at least one first transmission source to said at least one second transmission source when said first and second group identifications are different.

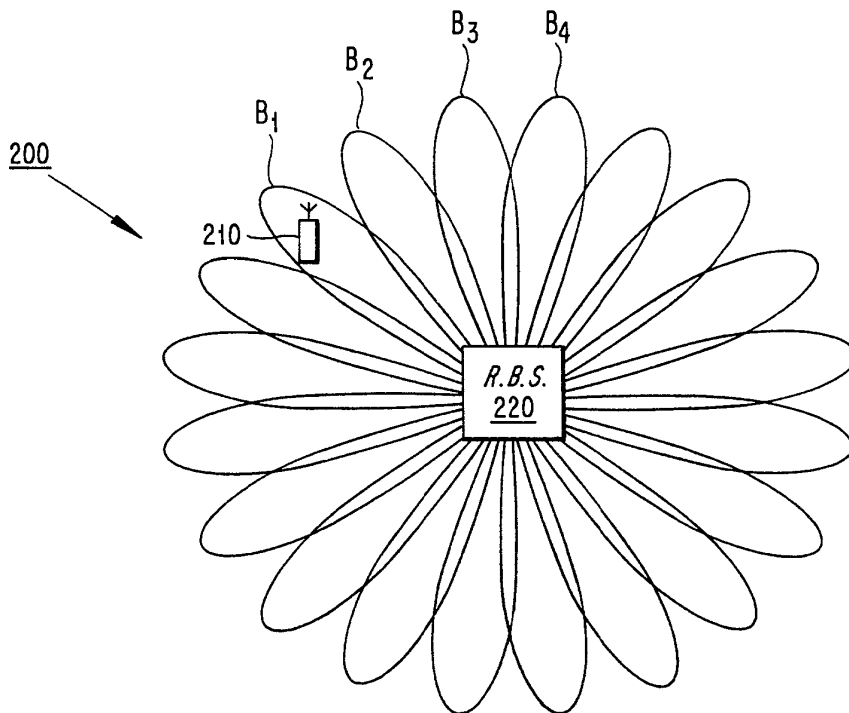


SUBSTITUTE SHEET (RULE 26)

2/5

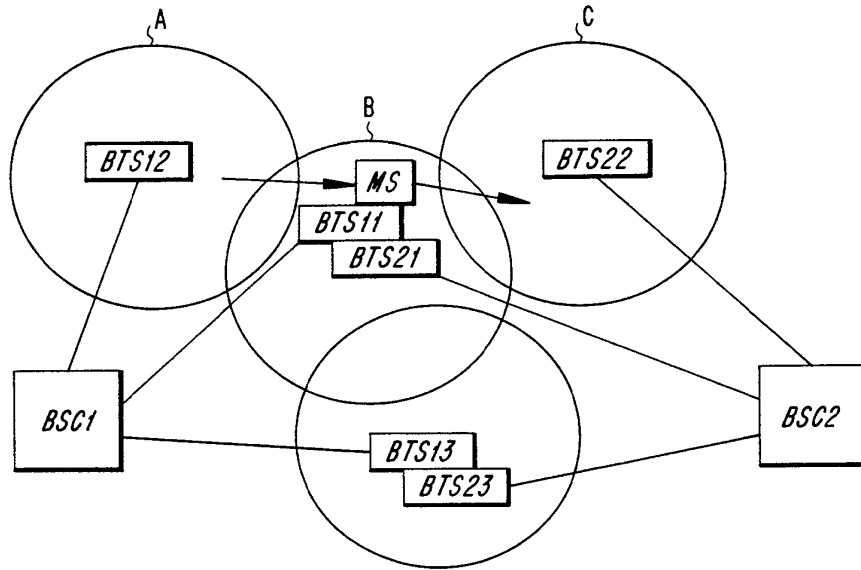


*Fig. 2*

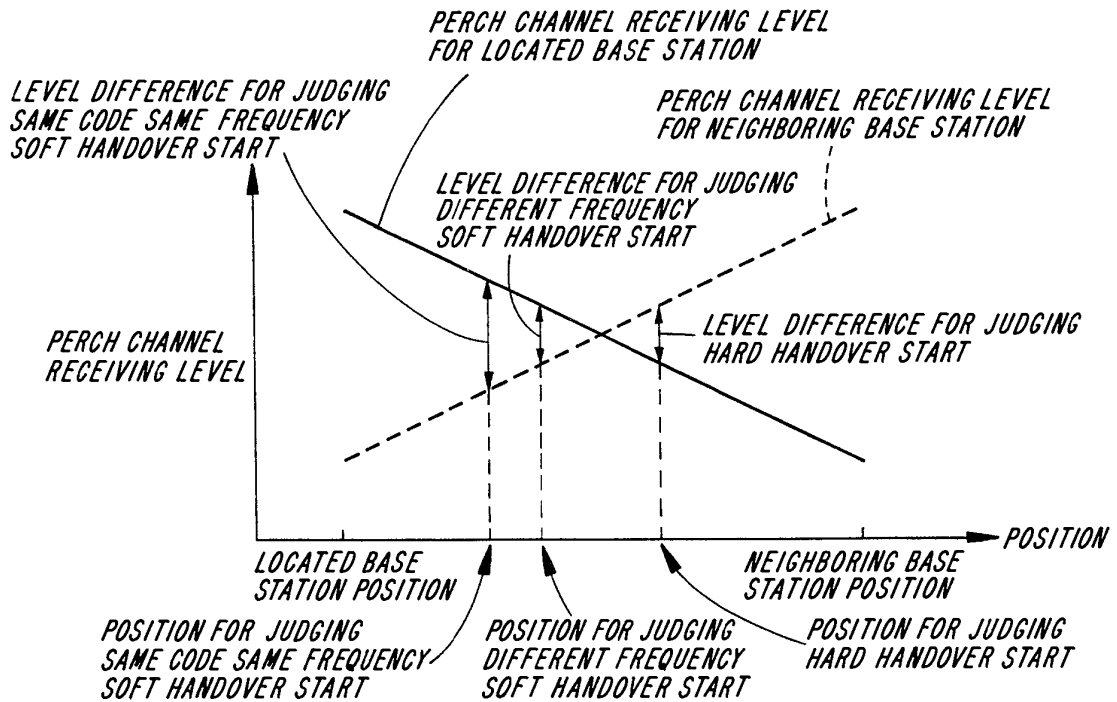


*Fig. 3*

SUBSTITUTE SHEET (RULE 26)



**Fig. 4**  
(PRIOR ART)



**Fig. 5**  
(PRIOR ART)  
SUBSTITUTE SHEET (RULE 26)

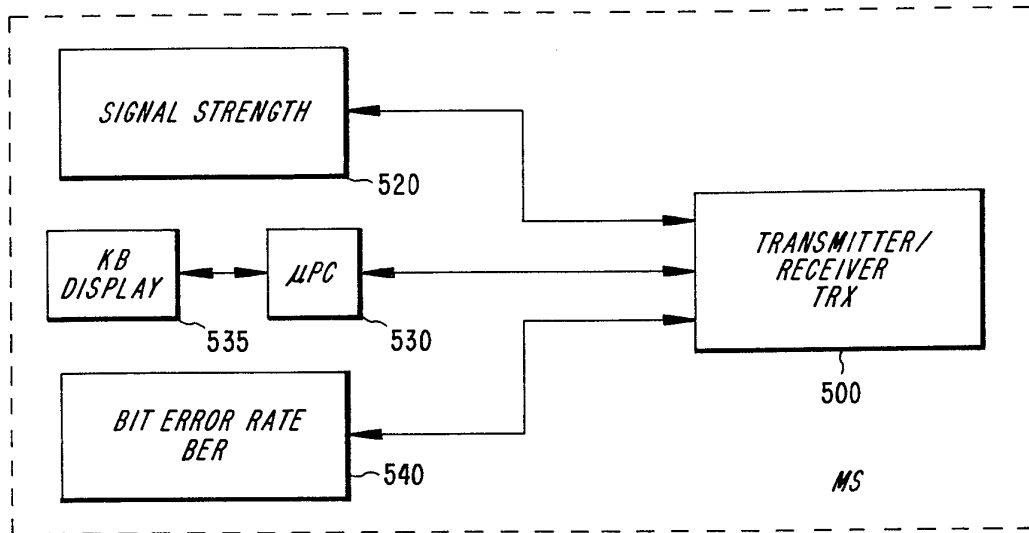


Fig. 6

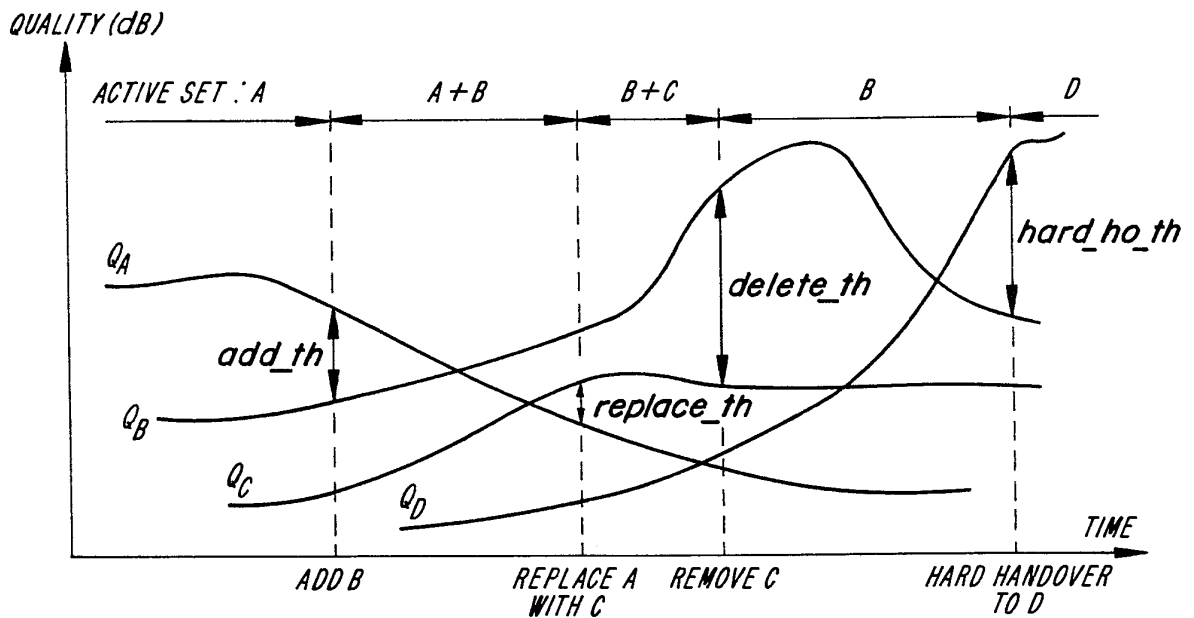


Fig. 7

SUBSTITUTE SHEET (RULE 26)

A, B: SOFTZONE SZ1  
C: SOFTZONE SZ2

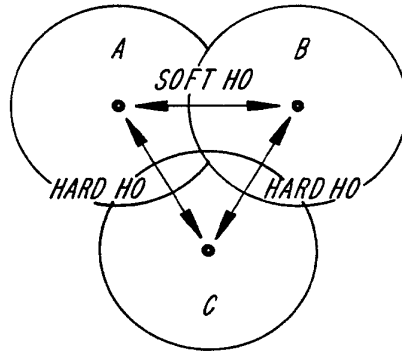


Fig. 8

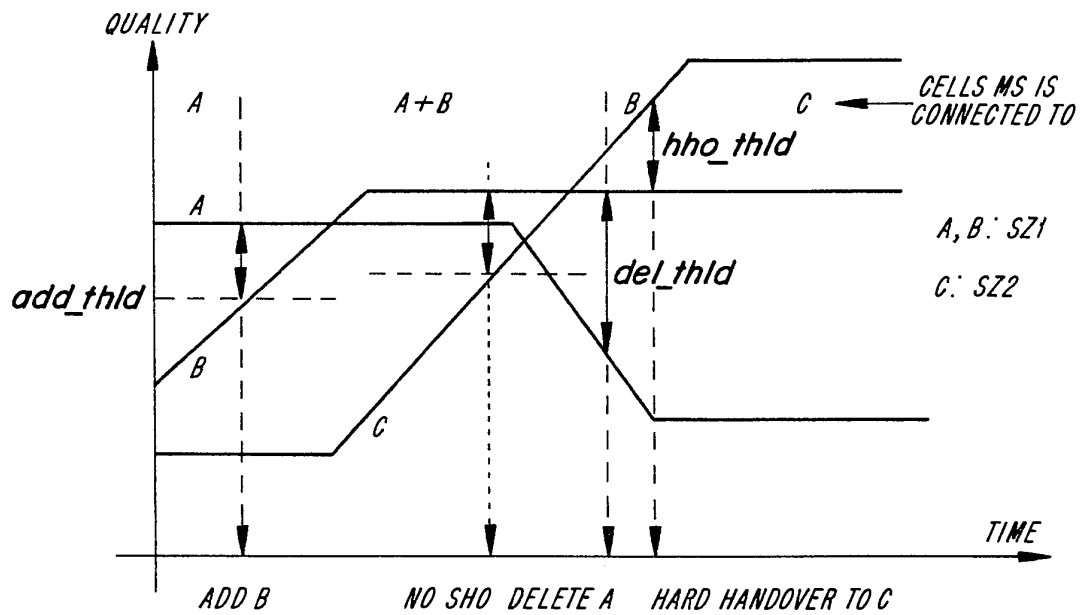


Fig. 9

SUBSTITUTE SHEET (RULE 26)

INTERNATIONAL SEARCH REPORT

International Application No

PCT/EP 99/10083

**A. CLASSIFICATION OF SUBJECT MATTER**  
 IPC 7 H04Q7/38

According to International Patent Classification (IPC) or to both national classification and IPC

**B. FIELDS SEARCHED**

Minimum documentation searched (classification system followed by classification symbols)  
 IPC 7 H04Q

Documentation searched other than minimum documentation to the extent that such documents are included in the fields searched

Electronic data base consulted during the international search (name of data base and, where practical, search terms used)

**C. DOCUMENTS CONSIDERED TO BE RELEVANT**

Category *	Citation of document, with indication, where appropriate, of the relevant passages	Relevant to claim No.
X  A	WO 96 31078 A (QUALCOMM INC) 3 October 1996 (1996-10-03)  page 2, line 10 - line 17 page 6, line 32 - line 34 page 7, line 30 - line 37 page 9, line 29 - line 38 page 14, line 25 - line 33 -----	1-7, 9-11, 13, 14, 16-18 8, 12, 15

Further documents are listed in the continuation of box C.

Patent family members are listed in annex.

\* Special categories of cited documents :

"A" document defining the general state of the art which is not considered to be of particular relevance

"E" earlier document but published on or after the international filing date

"L" document which may throw doubts on priority claim(s) or which is cited to establish the publication date of another citation or other special reason (as specified)

"O" document referring to an oral disclosure, use, exhibition or other means

"P" document published prior to the international filing date but later than the priority date claimed

"T" later document published after the international filing date or priority date and not in conflict with the application but cited to understand the principle or theory underlying the invention

"X" document of particular relevance; the claimed invention cannot be considered novel or cannot be considered to involve an inventive step when the document is taken alone

"Y" document of particular relevance; the claimed invention cannot be considered to involve an inventive step when the document is combined with one or more other such documents, such combination being obvious to a person skilled in the art.

"&" document member of the same patent family

Date of the actual completion of the international search

26 May 2000

Date of mailing of the international search report

07/06/2000

Name and mailing address of the ISA

European Patent Office, P.B. 5818 Patentlaan 2  
 NL - 2280 HV Rijswijk  
 Tel. (+31-70) 340-2040, Tx. 31 651 epo nl,  
 Fax: (+31-70) 340-3016

Authorized officer

Janyaszek, J-M



# INTERNATIONAL SEARCH REPORT

Information on patent family members

International Application No

PCT/EP 99/10083

Patent document cited in search report	Publication date	Patent family member(s)	Publication date
WO 9631078 A	03-10-1996	US 5594718 A	14-01-1997
		AU 697734 B	15-10-1998
		AU 5432396 A	16-10-1996
		BR 9607948 A	14-07-1998
		CA 2216635 A	03-10-1996
		EP 0818117 A	14-01-1998

---

Form PCT/ISA/210 (patent family annex) (July 1992)

(12) INTERNATIONAL APPLICATION PUBLISHED UNDER THE PATENT COOPERATION TREATY (PCT)

(19) World Intellectual Property Organization  
International Bureau



(43) International Publication Date  
30 November 2000 (30.11.2000)

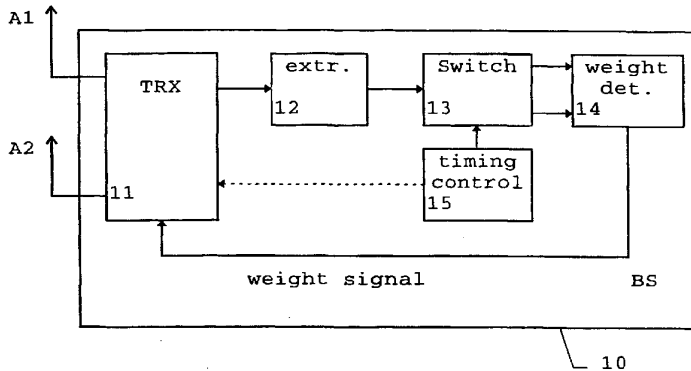
PCT

(10) International Publication Number  
**WO 00/72464 A1**

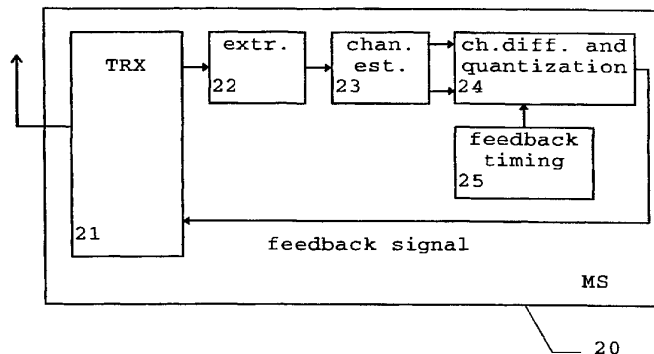
- (51) International Patent Classification<sup>7</sup>: **H04B 7/06**,  
H04L 5/12, 1/16
- (21) International Application Number: PCT/EP99/03440
- (22) International Filing Date: 19 May 1999 (19.05.1999)
- (25) Filing Language: English
- (26) Publication Language: English
- (71) Applicant (for all designated States except US): **NOKIA NETWORKS OY** [FI/FI]; Keilalahdentie 4, FIN-02150 Espoo (FI).
- (72) Inventors; and
- (75) Inventors/Applicants (for US only): **HOTTINEN, Ari** [FI/FI]; Nokia Research Center, Itämerenkatu 11-13, FIN-00045 Nokia Group (FI). **WICHMAN, Risto** [FI/FI];
- Nokia Research Center, Itämerenkatu 11-13, FIN-00045 Nokia Group (FI).
- (74) Agents: **PELLMANN, Hans-Bernd** et al.; Tiedtke-Bühling-Kinne, Bavariaring 4, D-80336 München (DE).
- (81) Designated States (national): AE, AL, AM, AT, AU, AZ, BA, BB, BG, BR, BY, CA, CH, CN, CU, CZ, DE, DK, EE, ES, FI, GB, GD, GE, GH, GM, HR, HU, ID, IL, IN, IS, JP, KE, KG, KP, KR, KZ, LC, LK, LR, LS, LT, LU, LV, MD, MG, MK, MN, MW, MX, NO, NZ, PL, PT, RO, RU, SD, SE, SG, SI, SK, SL, TJ, TM, TR, TT, UA, UG, US, UZ, VN, YU, ZA, ZW.
- (84) Designated States (regional): ARIPO patent (GH, GM, KE, LS, MW, SD, SL, SZ, UG, ZW), Eurasian patent (AM, AZ, BY, KG, KZ, MD, RU, TJ, TM), European patent (AT, BE, CH, CY, DE, DK, ES, FI, FR, GB, GR, IE, IT, LU, MC, NL, PT, SE), OAPI patent (BF, BJ, CF, CG, CI, CM, GA, GN, GW, ML, MR, NE, SN, TD, TG).

[Continued on next page]

(54) Title: TRANSMIT DIVERSITY METHOD AND SYSTEM



(57) Abstract: The invention relates to a transmit diversity method for a wireless communication system comprising a transmitting element and at least one receiver, wherein a transmission signal is transmitted from the transmitting element to the at least one receiver in accordance with a weight information determined in response to a feedback information. The feedback information is derived from the response at the at least one receiver to the transmission signal, and is fed back using multiplexed feedback signals. Multiple feedback signal quantization constellations and/or constellation specific feedback subchannels can be used for channel probing, such that the total feedback resolution and robustness can be enhanced, while maintaining low signaling capacity of the feedback channel.



WO 00/72464 A1



**Published:**

— *With international search report.*

*For two-letter codes and other abbreviations, refer to the "Guidance Notes on Codes and Abbreviations" appearing at the beginning of each regular issue of the PCT Gazette.*

- 1 -

**Transmit diversity method and system**FIELD OF THE INVENTION

5 The present invention relates to a transmit diversity method and system for a wireless communication system, such as the Universal Mobile Telecommunications System (UMTS) comprising a transmitting element and at least one receiver.

10

BACKGROUND OF THE INVENTION

Wideband Code Division Multiple Access (WCDMA) has been chosen as the radio technology for the paired bands of the UMTS. Consequently, WCDMA is the common radio technology standard for third-generation wide-area mobile communications. WCDMA has been designed for high-speed data services and, more particularly, Internet-based packet-data offering up to 2Mbps in indoor environments and over 384 kbps for wide-area.

20

The WCDMA concept is based on a new channel structure for all layers built on technologies such as packet-data channels and service multiplexing. The new concept also includes pilot symbols and a time-slotted structure which has led to the provision of adaptive antenna arrays which direct antenna beams at users to provide maximum range and minimum interference. This is also crucial when implementing wideband technology where limited radio spectrum is available.

30

The uplink capacity of the proposed WCDMA systems can be enhanced by various techniques including multi-antenna reception and multi-user detection or interference cancellation. Techniques that increase the downlink

35

- 2 -

capacity have not been developed with the same intensity. However, the capacity demand imposed by the projected data services (e.g. Internet) burdens more heavily the downlink channel. Hence, it is important to find techniques that  
5 improve the capacity of the downlink channel.

Bearing in mind the strict complexity requirements of terminals, and the characteristics of the downlink channel, the provision of multiple receive antennas is not a desired  
10 solution to the downlink capacity problem. Therefore, alternative solutions have been proposed suggesting that multiple antennas or transmit diversity at the base station will increase downlink capacity with only minor increase of complexity in terminal implementation.

15

According to the WCDMA system, a transmit diversity concept is under consideration which is mainly focused on the closed-loop (feedback) mode.

20 Fig. 1 shows an example of such a feedback mode for a downlink transmission between a base station (BS) 10 and a mobile terminal or mobile station (MS) 20. In particular, the BS 10 comprises two antennas A1 and A2, and the MS 20 is arranged to estimate the channel on the basis of two  
25 transmission signals received from the two antennas A1 and A2. Then, the MS 20 feeds back the discretized channel estimate to the BS 10. Naturally, it is desired to develop a robust and low-delay feedback signaling concept.

30 In WCDMA, three modes are suggested for the closed-loop concept which is optimized for two antennas. In the feedback (FB) mode 1 (also referred to as Selective Transmit Diversity (STD)), one bit per time slot is used to signal the "best" antenna from each terminal. The remaining  
35 closed-loop FB modes 2 and 3 provide a slower feedback

- 3 -

link, where feedback weights used for controlling the antennas A1 and A2 are modified after two or four 0.625 ms slots, respectively. In this case, the antennas A1 and A2 are co-phased so that transmitted signals sum up coherently in the MS 20, to thereby provide the best performance with low mobility "low multipath" environments.

Fig. 2 shows a table indicating characteristic parameters of the above FB modes 1 to 3. In particular,  $N_{FB}$  designates the number of feedback bits per time slot,  $N_W$  the number of bits per feedback signaling word,  $N_a$  the number of feedback bits for controlling an amplification or power at the antennas A1 and A2, and  $N_p$  the number of feedback bits for controlling a phase difference between the antennas A1 and A2. As can be gathered from the table of Fig. 2, one bit is fed back per time slot in each of the FB modes 1 to 3.

In the FB mode 1 (i.e. STD), the bit length of the feedback signaling word is one bit, which leads to an update rate of 1600/s (i.e. an update is performed at the BS 10 in every time slot). The feedback bit rate is 1600 bps and the feedback signaling word is used for controlling the power supplied to the antennas A1 and A2.

In the FB mode 2, the feedback signaling word comprises two bits, which leads to an update rate of 800/s, since an update is performed after both feedback bits have been received, i.e. after two time slots. The feedback signaling word is only used for controlling the phase difference between the two antennas A1 and A2.

In the FB mode 3, the bit length of the feedback signaling word is four, such that an update rate of 400/s is obtained, i.e. an update is performed every four time slots. In particular, one bit of the feedback signaling

- 4 -

word is used for controlling the amplification (power) at the antennas A1 and A2, and three bits are used for controlling their phase difference.

5 Fig. 3A shows a table indicating the feedback power control performed in the FB mode 1 or STD. Here, the MS 20 has to estimate the antenna with the smallest path loss. To this effect, the MS 20 estimates the channel power of all "competing antennas", and determines the one with the  
10 highest power. The required channel estimates are obtained e.g. from a common pilot channel transmitted with a known power from each antenna. The table in Fig. 3A shows the relationship between the feedback value and the power  $P_{A1}$  supplied to the antenna A1 and the power  $P_{A2}$  supplied to  
15 the antenna A2. Accordingly, one of the two antennas A1 and A2 is selected at the BS 10 in response to the feedback signaling value.

It is to be noted that the FB mode 1 may be implemented in  
20 an analog manner in the beam domain. In this case, the MS 20 signals to the BS 10 whether to rotate channel symbols transmitted from the antenna A2 by  $180^\circ$ . In this case, the BS 10 transmits simultaneously from both antennas A1 and  
25 A2. Thus, the phase difference between the antennas A1 and A2 is switched between  $0^\circ$  and  $180^\circ$  in response to the feedback value.

The other FB modes 2 and 3 relate to a feedback concept referred to as Transmission Antenna Array (TxAA), in which  
30 the MS 20 transmits estimated and quantized channel parameters to the BS 10 which then weights the transmitted signals accordingly.

Fig. 3B shows the feedback control performed in the FB mode  
35 2. In the FB mode 2, only a phase weight feedback value

- 5 -

comprising two bits is fed back to the BS 10. The phase difference indicated in the table of Fig. 3B defines the phase difference (in degree) between the antennas A1 and A2, which is to be established by the BS 10 in order to obtain an optimum coherence at the MS 20.

Fig. 3C shows the feedback control of the FB mode 3, wherein one bit, i.e. amplification bit, of the feedback signaling word is used for controlling the power of the antennas A1 and A2, and the other three bits, i.e. phase bits, are used for controlling the phase difference between the antennas A1 and A2. The left-hand table indicates the power control based on the amplification bit, wherein the power  $P_{A1}$  and  $P_{A2}$  supplied to the antennas A1 and A2, respectively, is switched between 20% and 80% of a predetermined value. The right-hand table shows the feedback control based on the three phase bits, wherein the phase difference can be quantified into eight different phase difference values to be established by the BS 10 in order to obtain an optimum coherence in the MS 20.

As regards the table of Fig. 2, it is to be noted that an equal power is applied to the antennas A1 and A2 in each case where  $N_a = 0$ . Furthermore, the antennas A1 and A2 are uniquely defined by their respective pilot codes of the CCPCH (Common Control Physical Channel) of the UMTS. The derived amplitude and phase applied to the antennas A1 and A2 is called a weight and the set of weights is grouped into a weight vector. Specifically, the weight vector for the present case of two antennas is given by

$$\underline{w} = \left[ \frac{\sqrt{P_{A1}}}{\sqrt{P_{A2}} \cdot \exp(j\pi\Delta\phi / 180)} \right]$$



- 6 -

wherein  $\Delta\phi$  denotes the phase difference (phase weight) fed back to the BS 10. In case the dimension of  $\underline{w}$  becomes larger than two, more than two antennas, i.e. an antenna array, are required, wherein a directional antenna is achieved by using relative phases between antennas. The estimated phase of the feedback signal in the complex plane is then used for controlling the transmit direction.

Hence, the current WCDMA transmit diversity feedback concept uses a 2, 4 or 8 phase constellation to signal the channel difference to the BS 10. However, the higher channel resolution provided by a higher constellation order is obtained at the expense of feedback signaling capacity. Thus, the resolution of the feedback signaling is limited by the feedback signaling capacity. Furthermore, the current concept imposes a delay of one or more slots in executing the weight change and this restricts applicability only to very slow fading channels.

20

#### SUMMARY OF THE INVENTION

It is therefore an object of the present invention to provide a method and system for transmit diversity or transmit beamforming, by means of which the resolution of the feedback signaling can be increased without increasing the feedback signaling capacity.

This object is achieved by a transmit diversity method for a wireless communication system comprising a transmitting element and at least one receiver, said method comprising the steps of:

transmitting from said transmitting element to said at least one receiver a transmission signal in accordance with a weight information determined in response to a feedback information;

- 7 -

deriving said feedback information from the response at said at least one receiver to said transmission signal; feeding back said feedback information using multiplexed feedback signals.

5

Additionally, the above object is achieved by a transmit diversity system for a wireless communication system, comprising:

transmitting means for transmitting a transmission signal  
10 from a transmitting element in accordance with a weight information determined in response to a feedback information; and

at least one receiver for receiving said transmission signal and deriving said feedback information from the  
15 response to said transmission signal;

wherein said at least one receiver comprises a feedback means for feeding back said feedback information using multiplexed feedback signals.

20 Furthermore, the above object is achieved by a transmitter for a wireless communication system, comprising:

extracting means for extracting a feedback information from a received signal;

transmitting means for transmitting a transmission signal  
25 from a transmitting element in accordance with a weight information;

determining means for determining the weight information in response to the extracted feedback information; and  
control means for controlling the determining means so as  
30 to determine said weight information in accordance with multiplexed feedback signals used for feeding back said feedback information.

Moreover, the above object is achieved by a receiver for a  
35 wireless communication system, comprising:

- 8 -

receiving means for receiving a transmission signal;  
deriving means for deriving a feedback information from the  
response to said transmission signal; and  
feedback means for feeding back said feedback information  
5 using multiplexed feedback signals.

Accordingly, the transmit resolution can be enhanced by  
maintaining the feedback channel resolution and capacity  
signaled from the receiver and performing a suitable  
10 feedback filtering at the transmitter in accordance with  
the time-varying feedback signal constellation. Thereby,  
the effective resolution of the total feedback signaling  
can be improved while maintaining the signaling channel  
capacity, since the feedback information can be divided and  
15 spread over different sets of time slots in accordance with  
the time-varying signal constellation, or by using multiple  
different constellations. The filtering is applied to at  
least two subchannels. The transmitting signal may comprise  
a probing signal used for channel measurements and channel  
20 quantization and an information transmitted via the  
dedicated channel on the basis of the transmit weights.

According to the invention, multiplexed feedback signals  
can be used for representing the quantized state of the  
25 channel. Thereby, the type, coding, partitioning or  
allocation of the feedback signals may differ in different  
multiplex subchannels defined by a time division, frequency  
division, or code division multiplexing scheme. -

30 Thus, the weights applied to the antennas A1 and A2 can be  
demultiplexed from the feedback channel and need not be  
identical with the feedback signaling of the current time  
slot received from the receiver. In particular, a multiplex  
timing can be arranged such that the current FB modes still  
35 can be established. Each subchannel may independently

- 9 -

define a basic resolution, and the subchannels may jointly define an increased resolution. According to the invention, at least two feedback subchannels are used. The multiplexed feedback signals are demultiplexed at the transmitting  
5 element and then filtered in order to obtain the desired transmit weights. Thus, a flexible feedback concept is achieved, in which the transmit weights are derived from the feedback signals but need not match them exactly.

10 Furthermore, a higher transmit weight resolution and robustness can be achieved e.g. by multiplexing different feedback signals which are to be combined in a suitable way, e.g. by a Finite Impulse Response (FIR) filtering or an Infinite Impulse Response (IIR) filtering, at the  
15 transmitter. The filtering can also take into account the reliability of the received feedback signals. Then, the filter can determine the weights based on a higher weighting of the reliable feedback signals. Therefore, the present FB mode 3 can be achieved, since it can be  
20 established on the basis of e.g. the present FB mode 2 by multiplexing two different feedback signals and filtering them suitably. In this case, the feedback signaling and the channel estimation can be maintained, while slightly changing the feedback signal determination. However, no  
25 changes are required to the common channels.

The length of the filter impulse response should be matched to the channel characteristics (e.g. Doppler spread) in the sense that longer filters can be used when channel changes  
30 are slow. The type of filter can be determined from the received signal or it can be negotiated between the transmitter and the receiver. Furthermore, the demultiplexing and subsequent filtering can be performed on the feedback signal or on the transmit weights to which the  
35 feedback signals correspond, or both. In particular, gain

- 10 -

and phase information can be filtered separately or jointly. The filter can operate as a predictor, so that transmit weights can be predicted based on the available smoothed information until the command is transmitted, 5 current weights and/or previous weights and/or received feedback commands. In addition, the filtering can be linear or non-linear. Furthermore, a robust filtering, e.g. using a median filtering, can be applied, which is preferred, since feedback errors may cause "outliers" weights, i.e. 10 erroneous weights due to a wrong index rather than an estimation error in determining the index/quantization.

Hence, the channel is quantized to a plurality of feedback signal quantization constellations, and each quantized 15 value is transmitted via different multiplexed feedback subchannels. Thereby, a user may use different channel quantization constellations at different quantization intervals which may possibly overlap. The different quantization constellations may be independent, e.g. 20 suitable rotations of each other, or may be formed in a dependent or hierarchical manner by a set partitioning, wherein the dependent constellations are jointly used to define the feedback signal with increasing accuracy (e.g. the first two bits transmitted in a first subchannel may 25 designate a weight quadrant, and the third bit transmitted in a second subchannel may specify one of two weight points within the weight quadrant). Furthermore, different quantization constellations can be provided for different users.

30 Preferably, the multiplexed feedback signals may comprise a first feedback signal having a first constellation and a second feedback signal having a second constellation. The first and second feedback signals may be transmitted in 35 different time slots and/or by using different codes.

- 11 -

The first feedback signal may define a first phase weight determined on the basis of a channel estimate, and the second feedback signal may define a second phase weight  
5 determined on the basis of a rotated constellation. In particular, the second phase weight may be based on a rotated channel estimate of the same constellation, or on a rotated channel estimate of another constellation, or on the basis of a quantization of the channel estimate to the  
10 second (rotated) constellation. The first and second feedback signals may be fed back in successive time slots. Moreover, the first feedback signal may define a real part of the weight information, and the second feedback signal may define an imaginary part of the weight information.

15

Alternatively, the first feedback signal may define a first feedback information to be used for updating a first beam of the transmitting element, and the second feedback signal may define a second feedback information to be used for  
20 updating a second beam of the transmitting element. In this case, the first feedback signal can be fed back during odd time slots and the second feedback signal during even time slots. The odd and even time slots may be used for controlling the same antenna (when the channel difference  
25 is used) or a first antenna and a second antenna, respectively, in different time instants. In the latter case, the first and second antennas are alternately used as a reference. Controlling both antennas, e.g. by  
30 transmitting control commands in an alternate manner to the transmitting element, is preferred in cases where the effective transmitting power of the controlled antenna can be reduced by the filtering. When both antennas are generally controlled, the effective transmitting power is distributed evenly and this simplifies the designs of a  
35 provided power amplifier. Another possible solution is to

- 12 -

use transmit diversity techniques where different users may control different antennas.

Furthermore, the first feedback signal may define a  
5 quadrant in a 4-PSK constellation, and the second feedback  
signal may define a constellation within said quadrant  
defined by said first feedback signal. The second feedback  
signal may define a differential change, a Gray-encoded  
sub-quadrant, or a combination thereof.

10 The multiplexed feedback signals may be transmitted by at  
least two users having different feedback signal  
constellations. Thereby, a flexible and readily adaptable  
transmit diversity system can be achieved. The at least two  
users may comprise a first set of users controlling weights  
15 at a first antenna of the transmitting element, and a  
second set of users controlling weights at a second antenna  
of said transmitting element. In this case, a useful  
balancing of the transmitting power between the first and  
second antennas can be provided, since some filtering or  
20 demultiplexing techniques may result in lower transmission  
power requirements at the controlled antenna.

Furthermore, the control means provided in the transmitter  
may comprise a switching means for alternately switching  
25 the first feedback signal and the second feedback signal to  
the determining means. The determining means may be  
arranged to derive the weight information from the first  
and second feedback signal.

30 Moreover, the control means may be arranged to control the  
transmitting means so as to alternately update a first beam  
of the transmitting element by using a first weight  
information determined on the basis of the first feedback  
signal, and a second beam of the transmitting element by

- 13 -

using a second weight information determined on the basis of the second feedback signal.

The transmitting element may be an antenna array. In this  
5 case, the feedback information can be used for controlling the direction of transmission of the array antenna. The transmission direction may be derived from at least one of the multiplexed feedback signals. Furthermore, the transmission direction may be derived from a phase estimate  
10 obtained from at least one feedback signal.

Furthermore, the deriving means of the receiver may comprise extracting means for extracting a probing signal transmitted with a known power, channel estimation means  
15 for performing a channel estimation on the basis of the extracted probing signal, and generating means for generating the multiplexed feedback signals on the basis of the channel estimation. The generating means may be arranged to generate the first and second feedback signal,  
20 wherein the feedback means may be arranged to feed back the first and second feedback signals as the multiplexed feedback signals. The first and second feedback signals may be fed back alternately by the feedback means, wherein a quantization of the feedback information is based on the  
25 latest channel estimate and an available one of the first and second constellation.

Moreover, the generating means may be arranged to generate the first feedback signal based on the channel estimate and  
30 the second feedback signal based on a rotation of the channel estimate by a predetermined angle. This can be implemented also by quantizing the same channel estimate to two constellations where, in this case, the second one is a rotated copy of the first one.

35



- 14 -

Alternatively, the generating means may be arranged to generate the first feedback signal based on a real part of the feedback information, and the second feedback signal based on an imaginary part of the feedback information.

5

As a further alternative, extracting means may be arranged to alternately extract a probing signal corresponding to a first beam and a probing signal corresponding to a second beam, and the generating means may be arranged to

10 alternately generate the first feedback signal based on a channel estimate for the first beam, and the second feedback signal based on a channel estimate for the second beam.

15

#### BRIEF DESCRIPTION OF THE DRAWINGS

In the following, the present invention will be described in greater detail on the basis of a preferred embodiment with reference to the accompanying drawings, in which:

20

Fig. 1 shows a principle block diagram of a closed-loop transmit diversity system comprising a base station and a mobile station,

25

Fig. 2 shows a table indicating characteristic parameters of the FB modes 1 to 3,

30

Figs. 3A to 3C show tables indicating characteristic parameters relating to the feedback control of the FB modes 1, 2 and 3, respectively,

Fig. 4 shows tables indicating characteristic parameters of the transmit diversity concept according to a first example of the preferred embodiment of the present invention,

35

- 15 -

Fig. 5 shows a principle block diagram of a base station and a mobile station according to the preferred embodiment of the present invention,

5 Fig. 6 shows a diagram of complex weight parameters according to the first example of the preferred embodiment,

Fig. 7 shows tables indicating characteristic parameters of the transmit diversity concept according to a second  
10 example of the preferred embodiment,

Fig. 8 shows a diagram of complex weight parameters according to the second example of the preferred  
15 embodiment.

#### DESCRIPTION OF THE PREFERRED EMBODIMENT

In the following, the preferred embodiment of the method and system according to the present invention will be  
20 described on the basis of a connection between the BS 10 and the MS 20 of the UMTS, as shown in Fig. 1.

According to the preferred embodiment of the present invention, the feedback information is transmitted from the  
25 MS 20 to the BS 10 using a feedback concept based on time multiplexing. This means that the constellation of the feedback signals is changed and signaled to the BS 10 in different time slots. However, any other multiplex scheme such as frequency multiplexing or code multiplexing may be  
30 used as well in the feedback channel.

In particular, the feedback signal constellation may be changed with respect to the coding, type, partitioning or allocation of the feedback information. Thus, with the  
35 present time multiplexed feedback subchannels, the

- 16 -

signaling capacity required in the feedback channel can be maintained, while the feedback information as such is spread over the time axes, i.e. transmitted in two or more (sets of) time slots which may be allocated according to a predefined rule, known to both the BS 10 and the MS 20.

In the following, three examples of the preferred embodiment are described with reference to Figs. 4 to 8, wherein the feedback information is spread over successive time slots.

Fig. 4 shows two tables indicating a refined mode 2 concept. According to this example, two reference channels, i.e. the channel estimate and a rotated channel estimate, are used in the MS 20 in order to derive the feedback information. Thereby, an 8-phase signaling can be implemented by using the mode 2 feedback signaling, i.e. two feedback bits. In particular, a first feedback information relating to the channel estimate is transmitted in two successive time slots, and a second feedback information relating to the rotated channel estimate is transmitted in the following two successive time slots. Thus, the whole feedback information is transmitted in four successive time slots. Accordingly, the phase difference relating to the channel estimate is transmitted in slots  $S1 = \{1, 2, 5, 6, 9, 10, \dots\}$  defining a first feedback subchannel, and the phase difference quantized to the rotated constellation is transmitted in slots  $S2 = \{3, 4, 7, 8, 11, 12, \dots\}$  defining a second feedback subchannel, wherein the rotated channel estimate relates to a  $45^\circ$  rotated channel estimate, assuming a 4-phase constellation is used.

Thus, the effective phase differences for the phase bits transmitted in the slots  $S1$  is indicated by the upper table

- 17 -

of Fig. 4, and the phase difference defined by the phase bits transmitted in the slots S2 is indicated in the lower table of Fig. 4. Accordingly, the phase difference can be quantized into 8 values while using only two bits of  
5 feedback information at a time, as in the FB mode 2. The resulting feedback resolution obtained by a filtering or demultiplexing operation at the BS 10 corresponds to the FB mode 3, with the exception that a constant power is used for each of the antennas A1 and A2. Thus, the feedback  
10 resolution can be increased while maintaining the feedback signaling capacity of the FB mode 2.

Fig. 5 shows a principle block diagram of the MS 20 and the BS 10 according to the preferred embodiment of the present  
15 invention.

According to the Fig. 5, the BS 10 comprises a transceiver (TRX) 11 arranged for feeding the two antennas A1 and A2 and connected to an extracting unit 12 provided for  
20 extracting the feedback information transmitted from the MS 20 via the corresponding feedback channel(s). The extracted feedback information is supplied to a switch 13 which is controlled by a timing control unit 15 in accordance with the timing scheme underlying the multiplex scheme of the  
25 feedback signal constellation used by the MS 20. Thereby, a demultiplexing or filtering function for extracting the feedback information is provided. In the present example, the switch 13 is controlled by the timing control unit 15 so as to supply the feedback information relating to the  
30 slots S1 to one of its output terminals and the feedback information transmitted in the slots S2 to the other one of its output terminals.

It is noted that the above demultiplexing or filtering  
35 function may alternatively be achieved by providing filter

- 18 -

and demodulating unit or a decoding unit, in case a frequency or, respectively, code multiplex scheme is used.

The output terminals of the switch 13 are connected to  
5 respective input terminals of a weight determination unit  
14 which determines a weight signal on the basis of the  
tables shown in Fig. 4. In particular, the weight  
determination unit 14 determines the required phase  
10 difference between the antennas A1 and A2 by averaging the  
feedback information of the two slot types S1 and S2  
received via the respective input terminals. However, any  
other combination of the two feedback informations may be  
provided.

15 The determined weight signal, e.g. phase difference, is  
supplied to the TRX 11 which performs a corresponding phase  
control of the antennas A1 and A2 to thereby establish the  
required phase difference leading to an optimum coherence  
of the transmission signals in the MS 20.

20 The MS 20 comprises a transceiver (TRX) 21 for receiving  
the transmission signals from the antennas A1 and A2 of the  
BS 10 via an antenna connected thereto. Furthermore, the  
TRX 21 is connected to an extracting unit 22 provided for  
25 extracting the pilot channel signal and supplying the  
extracted pilot channel signal to a channel estimation unit  
23 which calculates the required channel estimates. In  
particular, the channel estimation unit 23 is arranged to  
calculate the channel estimate and the rotated channel  
30 estimate both corresponding to the received pilot channel  
signal. The channel estimation unit 23 outputs the two  
channel estimates at respective output terminals thereof  
which are connected to corresponding input terminals of a  
channel difference deriving and quantization unit 24 for  
35 deriving a phase difference based on the channel estimate

- 19 -

and the rotated channel estimate obtained from the channel estimation unit 23 and performing a corresponding quantization. As already mentioned, the rotated channel estimate is obtained by rotating the channel estimate by an angle of  $45^\circ$ .

Furthermore, a feedback timing unit 25 is provided which controls the phase difference deriving and quantization unit 24 so as to output one of the phase differences derived from the channel estimate and the rotated channel estimate in accordance with the predetermined feedback timing. In the present case, the phase difference corresponding to the channel estimate, i.e. conventional FB mode 2, is outputted during the time slots S1, and the phase difference corresponding to the rotated channel estimate is outputted during the time slots S2. The phase differences are supplied as a multiplexed feedback signal to the TRX 21 in order to be transmitted via the corresponding feedback channel to the BS 10.

It is to be noted that the transmit diversity concept according to the first example of the preferred embodiment is compatible with the known FB mode 2, in case the BS 10 assumes each feedback information as derived only from the channel estimate which has not been rotated, i.e. the known BS 10 controlled according to the FB mode 2.

In case a frequency or code multiplex feedback scheme is used, the feedback timing unit 25 may be replaced by a modulating unit or, respectively, a coding unit.

Fig. 6 shows a diagram of the complex weights or end points of the weight vectors used as the feedback information in the first example of the preferred embodiment. In particular, the circles in the diagram of Fig. 6 indicate

- 20 -

the weights obtained in the slots S1, i.e. the weight of the conventional FB mode 2, and the crosses indicate the additional weights obtained in the time slots S2. Thus, a phase difference quantization as provided in the FB mode 3  
5 can be obtained without increasing the feedback channel signaling capacity.

Fig. 7 shows a second example of the preferred embodiment, wherein the feedback resolution of the FB mode 2 is  
10 obtained while using only a single feedback bit. Thus, this example relates to a refined FB mode 1. In particular, the MS 20 performs a continuous measurement or channel estimation, e.g. on the basis of a sliding window, and the phase difference deriving unit 24 quantizes the phase  
15 difference in accordance with the FB mode 2 phase constellation. In the present case, the feedback bits for the real and imaginary part of the complex weight, determined by the phase difference, are transmitted in successive slots, e.g. the real part bit in the odd slots  
20 used as a first feedback subchannel and the imaginary part bit in the even slots used as a second subchannel. A corresponding control is performed by the feedback timing unit 25 of the MS 20.

25 Correspondingly, the timing control unit 15 of the BS 10 controls the switch 13 so as to supply the successive real and imaginary part of the feedback information to respective input terminals of the weight determination unit 14 which determines the corresponding weight signal  
30 supplied to the TRX 11 in order to establish the required phase difference.

In case the BS 10 is not controlled in accordance with this time control scheme, i.e. the current FB mode 1 is used,  
35 the conventional control is obtained. If the new timing

- 21 -

control is provided, the weight determination unit 14 averages over two slots and changes the weight signal correspondingly.

5 Thus, an FB mode 2 resolution is obtained with an FB mode 1 feedback capacity. Moreover, an antenna verification can be incorporated separately for the successive bits, which corresponds to the STD concept.

10 Thus, as can be gathered from Fig. 7, the feedback information provided in the odd slots  $S_{\text{odd}}$  indicates a phase difference of  $0^\circ$  or  $180^\circ$ , and the feedback information provided in the even slots  $S_{\text{even}}$  indicates a phase difference of  $-90^\circ$  or  $+90^\circ$ .

15

Fig. 8 shows a diagram of the complex weights which can be fed back in the second example of the preferred embodiment, wherein the crosses indicate the weight information transmitted in the slots  $S_{\text{even}}$  and the circles indicate the weights transmitted in the slots  $S_{\text{odd}}$ .

20

According to a third example of the preferred embodiment, a beam diversity concept can be adopted by the feedback scheme in order to provide an enhanced robustness against erroneous signaling. In the third example, it is assumed that a space time coding (STTD) is used at the MS 20, wherein encoded channel symbols are divided into two-element blocks and transmitted as  $b[2n]$ ,  $b[2n+1]$  and  $-b^*[2n+1]$ ,  $b^*[2n]$  from the antennas A1 and A2, respectively, during time instants  $2n$  and  $2n+1$  using the same spreading code. This simple symbol level orthogonal coding scheme doubles the time diversity, wherein the receiver uses a simple linear decoding to detect the transmitted symbols. In the present case, two weight vectors are used, which are a function of the received signaling. In case of the FB

35



- 22 -

mode 1 feedback signaling, the following processing is performed.

Two beams B1 and B2 are transmitted by the antennas A1 and  
5 A2 of the BS 10 in each time slot. The update rate of the  
beams B1 and B2 is 800 Hz, i.e. the TRX 11 is updated every  
other time slot. In particular, the beam B1 is modified  
during odd slots and the beam B2 during even slots, where  
each weight modification is effective over two time slots,  
10 i.e. a sliding window weight change is provided. Hence, the  
extracting unit 22 of the MS 20 is arranged to extract the  
corresponding probing or pilot signals received from the  
the beams B1 and B2, and to successively supply them to the  
channel estimation unit 23. Then, the feedback timing unit  
15 25 controls the phase difference deriving unit 24 so as to  
output the respective phase differences at timings  
corresponding to their allocated time slots.

It is to be noted that the filtering function provided by  
20 the switch unit 13 and the timing control unit 15 of the BS  
10 is not required in the present case, if the TRX 11 is  
arranged to determine and correspondingly allocate  
successively received weight signals to their respective  
beams B1 or B2. However, if this is not the case, the  
25 timing control unit 15 controls the switch 13 so as to  
switch the weight signal of the beam B1 (transmitted in an  
odd slot) to one of its output terminals and the weight  
signal of the beam B2 (transmitted in an even slot) to the  
other output terminal and the weight determination unit 14  
30 determines the corresponding weight signal. In addition,  
the timing control unit 15 is arranged to control the TRX  
11 so as to allocate the received weight signal to the  
corresponding one of the beams B1 and B2. This control  
feature is indicated by the broken error shown in the block  
35 diagram of the BS 10 of Fig. 5.

- 23 -

It is to be noted that the above described units of the block diagram shown in Fig. 5 may as well be established as software features of a control program controlling a microprocessor such as a CPU provided in the BS 10 and the MS 20.

Furthermore, any kind of signal set partitioning (e.g. for trellis codes) may be used to improve the performance.

10 Furthermore, the different feedback signal constellations may be dependent by using a progressive signaling. For example, a first time slot or subchannel can be used for feeding back an information indicating a quadrant in a 4-PSK constellation with higher reliability, and a subsequent

15 second time slot or subchannel can be used for feeding back an information determining the constellation within this quadrant. The feedback information of the second subchannel may be based on a differential change, a Gray-encoded sub-quadrant, or any combination thereof. Here, the transmit

20 weights can be changed as soon as the feedback bits specifying the quadrant have arrived at the BS 10, and the refined subquadrant can be adjusted thereafter based on the most recent channel estimate, which was not available when the quadrant index was transmitted (e.g. using Gray

25 encoding). Thereby, additional delay caused in the current concept by waiting for the receipt of all feedback bits can be prevented. Furthermore, abrupt changes (180 degree in case of one bit feedback, 90 degrees in case of two bit feedback, and so on), as in the current concepts, which

30 cannot be followed by the MS 20 estimating the dedicated channel parameters do not occur. Hence, applying the feedback information incrementally not only reduces delay, but also enables more efficient channel estimation and receiver performance. The feedback information may also

35 refer to the phase difference of successive slots.

- 24 -

Furthermore, the present invention is not limited to two antennas A1 and A2, but can be applied to any multi-antenna transmitter in order to provide a higher resolution  
5 feedback. Moreover, as already mentioned, any kind of multiplex scheme can be used, provided the BS 10 is arranged to correspondingly filter or select the feedback information.

10 Furthermore, the present invention may be applied to any wireless communication system comprising a transmit diversity or transmit beamforming concept used between a transmitting element and at least one receiver. Therefore,  
15 the above description of the preferred embodiment and the accompanying drawings are only intended to illustrate the present invention. The preferred embodiment of the invention may vary within the scope of the attached claims.

In summary, the invention relates to a transmit diversity  
20 method for a wireless communication system comprising a transmitting element and at least one receiver, wherein a transmission signal is transmitted from the transmitting element to the at least one receiver in accordance with a weight information determined in response to a feedback  
25 information. The feedback information is derived from the response at the at least one receiver to the transmission signal, and is fed back using multiplexed feedback signals. Thus, multiple quantization constellations and/or  
30 constellation specific feedback subchannels can be used for channel probing, such that the total feedback resolution can be enhanced, while maintaining low signaling capacity of the feedback channel.

- 25 -

**Claims**

1. A transmit diversity method for a wireless communication system comprising a transmitting element and  
5 at least one receiver, said method comprising the steps of:  
a) transmitting from said transmitting element to said at least one receiver a transmission signal in accordance with a weight information determined in response to a feedback information;  
10 b) deriving said feedback information from the response at said at least one receiver to said transmission signal;  
c) feeding back said feedback information using multiplexed feedback signals.
- 15 2. A method according to claim 1, wherein said multiplexed feedback signals comprises a first feedback signal having a first quantization constellation and a second feedback signal having a second quantization constellation.
- 20 3. A method according to claim 2, wherein said first and second feedback signals are transmitted in different time slots.
- 25 4. A method according to claim 2 or 3, wherein said first and second feedback signals are transmitted using different codes.
- 30 5. A method according to anyone of claims 2 to 4, wherein said first feedback signal defines a first weight determined on the basis of a channel estimate quantized to said first constellation, and said second feedback signal defines a second weight determined on the basis of a channel estimate quantized to said second constellation.

35

- 26 -

6. A method according to claim 5, wherein said second constellation is a rotated copy of said first constellation.
- 5 7. A method according to claim 5, wherein said second feedback signal is based on a rotated channel estimate quantized to said first constellation.
8. A method according to claims 2 or 3, wherein said  
10 first and second feedback signals are fed back in successive time slots.
9. A method according to anyone of claims 2, 3 or 8,  
15 wherein said first feedback signal defines a real part of said weight information, and said second feedback signal defines an imaginary part of said weight information.
10. A method according to anyone of claims 2, 3 or 8,  
20 wherein said first feedback signal defines a first feedback information to be used for updating a first beam of said transmitting element, and said second feedback signal defines a second feedback information to be used for updating a second beam of said transmitting element.
- 25 11. A method according to claim 9 or 10, wherein said first feedback signal is fed back during odd time slots, and said second feedback signal is fed back during even time slots.
- 30 12. A method according to anyone of claims 2, 3 or 8, wherein said first feedback signal defines a quadrant in a 4-PSK constellation, and said second feedback signal defines a constellation point within said quadrant defined by said first feedback signal.

35

- 27 -

13. A method according to claim 12, wherein said second feedback signal defines a differential change, a Gray-encoded sub-quadrant, or a combination thereof.

5 14. A method according to claim 1, wherein said multiplexed feedback signals are transmitted by at least two users having different signal constellations.

10 15. A method according to claim 14, wherein said at least two users comprise a first set of users controlling weights at a first antenna of said transmitting element, and a second set of users controlling weights at a second antenna of said transmitting element.

15 16. A method according to claim 1, wherein said feedback information is used for controlling a transmit weight of one of two antennas.

20 17. A method according to claim 1, wherein said feedback information is used for controlling transmit weights of two antennas.

25 18. A method according to claim 17, wherein control commands for controlling said two antennas are transmitted alternately to said transmitting element.

19. A method according to claim 1, wherein said transmitting element comprises an antenna array.

30 20. A method according to claim 19, wherein said feedback information is used for controlling the direction of transmission of said antenna array.

- 28 -

21. A method according to claim 20, wherein the direction of transmission is derived from at least one feedback signal.
- 5 22. A method according to claim 21, wherein the direction of transmission is derived from a phase estimate of at least one extracted feedback signal.
23. A method according to claim 1, wherein said weight  
10 information and/or a direction of transmission are determined on the basis of a feedback signal filtering operation.
24. A method according to claim 23, wherein said filtering  
15 operation comprises a robust filtering, an FIR filtering, an IIR filtering, a linear filtering, a non-linear filtering, or a smoothing and prediction.
25. A method according to anyone of the preceding claims,  
20 wherein a reliability of said multiplexed feedback signals is used for weight determination.
26. A method according to claim 23 or 24, wherein a transmission filtering is adapted to a transmission channel  
25 characteristic and changed dynamically.
27. A transmit diversity system for a wireless communication system, comprising:
- a) transmitting means **(10)** for transmitting a  
30 transmission signal from a transmitting element **(A1, A2)** in accordance to with a weight information determined in response to a feedback information; and
- b) at least one receiver **(20)** for receiving said transmission signal and deriving said feedback information  
35 from the response to said transmission signal;

- 29 -

c) wherein said at least one receiver (20) comprises feedback means (24, 25) for feeding back said feedback information using multiplexed feedback signals.

5 28. A system according to claim 27, wherein said feedback means (24, 25) is arranged to generate a first feedback signal having a first constellation and a second feedback signal having a second constellation.

10 29. A system according to claim 28, wherein said first feedback signal defines a first phase weight determined on the basis of a channel estimate, and said second feedback signal defines a second phase weight determined on the basis of a rotated constellation of said first feedback  
15 signal.

30. A system according to claim 28, wherein said first feedback signal defines a real part of said weight information, and said second feedback signal defines an  
20 imaginary part of said weight information.

31. A system according to claim 28, wherein said first feedback signal defines a first feedback information to be used by said transmitting means (10) for updating a first  
25 beam of said transmitting element (A1, A2), and said second feedback signal defines a second feedback information to be used by said transmitting means (10) for updating a second beam of said transmitting element (A1, A2).

30 32. A system according to claim 30 or 31, wherein said feedback means (24, 25) is arranged to feed back said first feedback signal during odd time slots and said second feedback signal during even time slots.



- 30 -

33. A transmitter for a wireless communication system, comprising:

- a) extracting means **(12)** for extracting a feedback information from a received signal;
- 5 b) transmitting means **(11)** for transmitting a transmission signal from a transmitting element **(A1, A2)** in accordance with a weight information;
- c) determining means **(14)** for determining said weight information in response to said extracted feedback information; and
- 10 d) control means **(13, 15)** for controlling said determining means **(14)** so as to determine said weight information in accordance with multiplexed feedback signals used for feeding back said feedback information.

15

34. A transmitter according to claim 33, wherein said control means **(13, 15)** comprises a switching means **(13)** for alternately switching a first feedback signal having a first constellation and a second feedback signal having a second constellation to said determining means **(14)**.

20

35. A transmitter according to claim 34, wherein said determining means **(14)** is arranged to derive said weight information from said first and second feedback signals.

25

36. A transmitter according to claim 34, wherein said control means **(13, 15)** is arranged to control said transmitting means **(11)** so as to alternately update a first beam of said transmitting element **(A1, A2)** by using a first weight information determined on the basis of said first feedback signal, and a second beam of said transmitting element **(A1, A2)** by using a second weight information determined on the basis of said second feedback signal.

30

- 31 -

37. A transmitter according to anyone of claims 33 to 36, wherein said transmitting element is an antenna array (**A1**, **A2**).

5 38. A receiver for a wireless communication system, comprising:

a) receiving means (**21**) for receiving a transmission signal;

b) deriving means (**22, 23, 24**) for deriving a feedback information from the response to said transmission signal; and

10 c) feedback means (**24, 25**) for feeding back said feedback information using multiplexed feedback signals.

15 39. A receiver according to claim 38, wherein said deriving means (**22, 23, 24**) comprises extracting means (**22**) for extracting a probing signal transmitted with a known power, channel estimation means (**23**) for performing a channel estimation on the basis of said extracted probing signal, and generating means (**24**) for generating said multiplexed feedback signals on the basis of said channel estimation.

25 40. A receiver according to claim 39, wherein said generating means (**24**) is arranged to generate a first feedback signal having a first constellation and a second feedback signal having a second constellation, wherein said feedback means (**24, 25**) is arranged to feed back said first and second feedback signals as said multiplexed feedback signals.

35 41. A receiver according to claim 40, wherein said feedback means (**24, 25**) is arranged to alternately feed back said first and second feedback signals, wherein a quantization of the feedback information is based on the

- 32 -

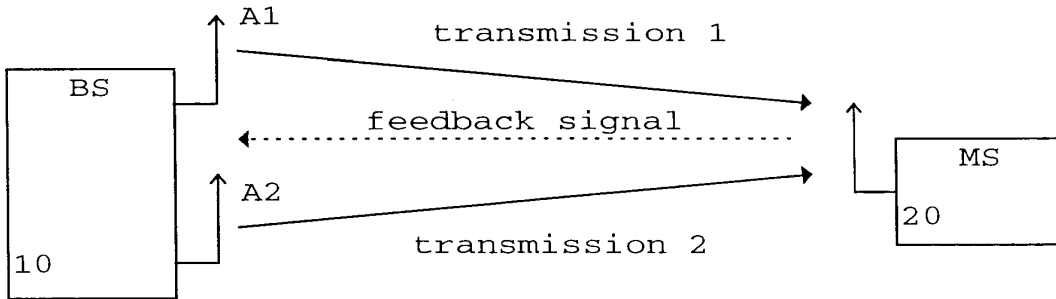
latest channel estimate and an available one of said first and second constellation.

42. A receiver according to claim 40, wherein said  
5 generating means **(24)** is arranged to generate said first feedback signal based on said channel estimation and said second feedback signal based on a rotation of said channel estimation by a predetermined angle.

10 43. A receiver according into claim 40, wherein said generating means **(24)** is arranged to generate said first feedback signal based on a real part of said feedback information, and said second feedback signal based on an imaginary part of said feedback information.

15 44. A receiver according to claim 40, wherein said extracting means **(22)** is arranged to alternately extract a probing signal corresponding to a first beam and a probing signal corresponding to a second beam, and said generating  
20 means **(24)** is arranged to alternately generate said first feedback signal based on a channel estimate for said first beam, and said second feedback signal based on a channel estimate for said second beam.

25



**Fig. 1**

FB mode	$N_{FB}$	$N_w$	update rate	feedback bit rate	$N_a$	$N_p$
1	1	1	1600/s	1600bps	1	0
2	1	2	800/s	1600bps	0	2
3	1	4	400/s	1600bps	1	3

**Fig. 2**

feedback value	$P_{A1}$	$P_{A2}$
0	0	1
1	1	0

**Fig. 3A**

feedback value	phase - diff.
0 0	180°
0 1	-90°
1 1	0°
1 0	90°

**Fig. 3B**

ampl. bit	P <sub>A1</sub>	P <sub>A2</sub>
0	0.2	0.8
1	0.8	0.2

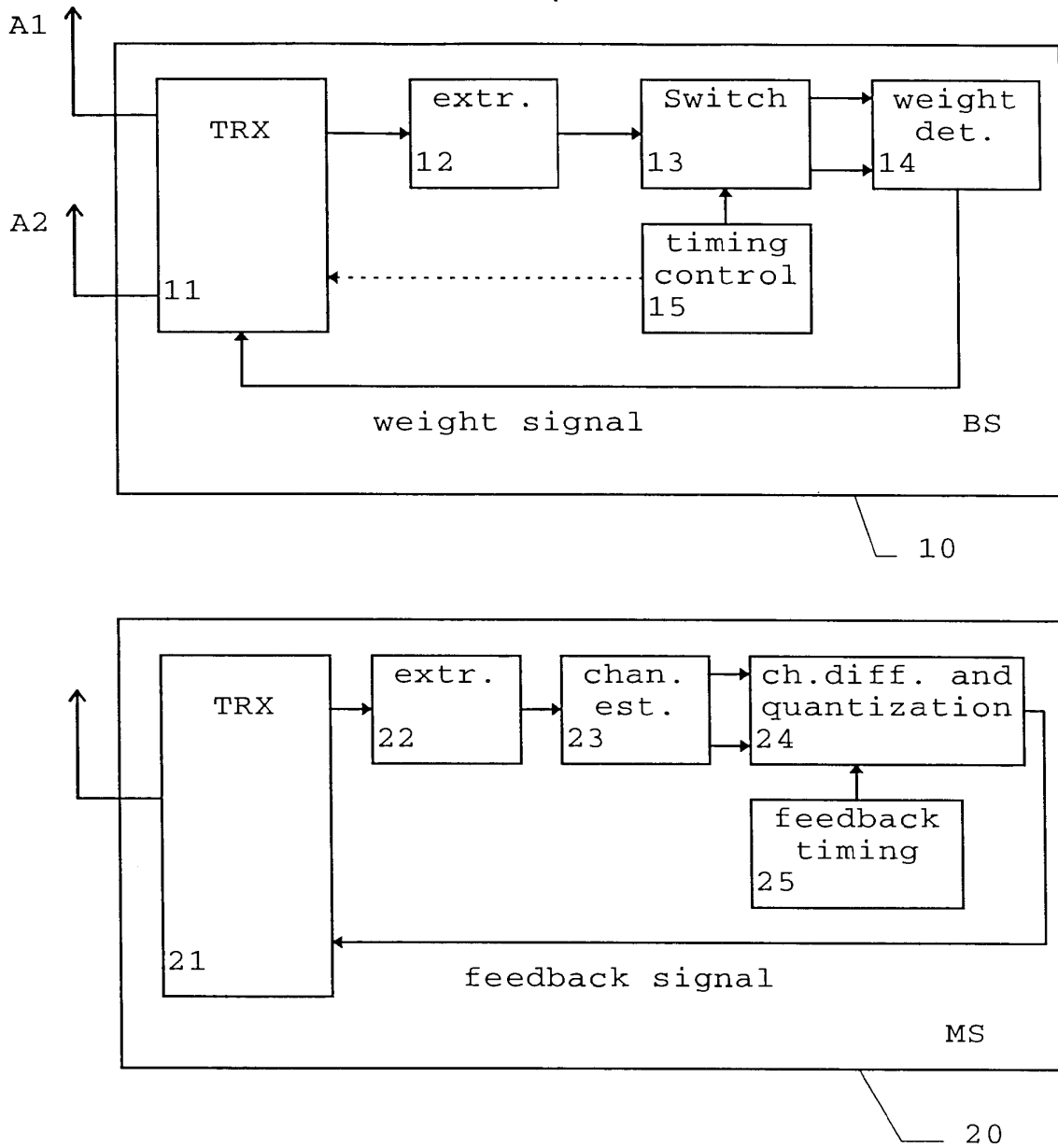
phase bits	phase diff.
0 0 0	180°
0 0 1	-135°
0 1 1	-90°
0 1 0	-45°
1 1 0	0°
1 1 1	45°
1 0 1	90°
1 0 0	135°

**Fig. 3C**

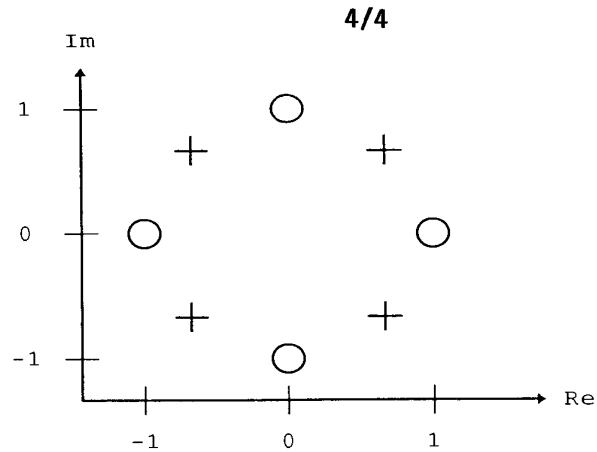
phase bits (slots S1)	phase difference
0 0	180°
0 1	-90°
1 1	0°
1 0	90°

phase bits (slots S2)	phase difference
0 0	-135°
0 1	-45°
1 1	45°
1 0	135°

**Fig. 4**



**Fig. 5**

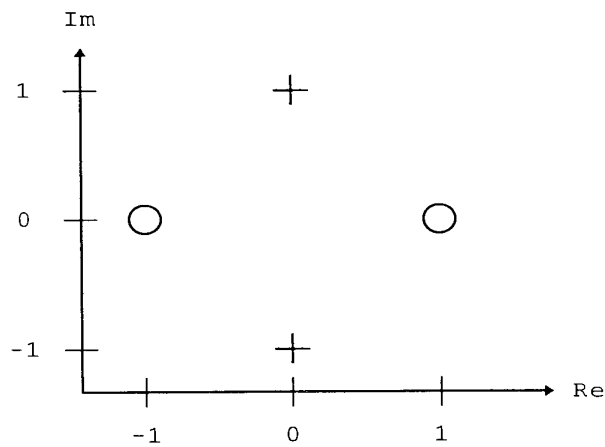


**Fig. 6**

phase bit ( $S_{odd}$ )	phase difference
0	180°
1	0°

phase bit ( $S_{even}$ )	phase difference
0	-90°
1	+90°

**Fig. 7**



**Fig. 8**

# INTERNATIONAL SEARCH REPORT

International Application No  
PCT/EP 99/03440

<b>A. CLASSIFICATION OF SUBJECT MATTER</b> IPC 7 H04B7/06 H04L5/12 H04L1/16				
According to International Patent Classification (IPC) or to both national classification and IPC				
<b>B. FIELDS SEARCHED</b> Minimum documentation searched (classification system followed by classification symbols) IPC 7 H04B H04L H04Q				
Documentation searched other than minimum documentation to the extent that such documents are included in the fields searched				
Electronic data base consulted during the international search (name of data base and, where practical, search terms used)				
<b>C. DOCUMENTS CONSIDERED TO BE RELEVANT</b>				
Category <sup>o</sup>	Citation of document, with indication, where appropriate, of the relevant passages	Relevant to claim No.		
A	EP 0 755 127 A (NIPPON ELECTRIC CO) 22 January 1997 (1997-01-22) column 3, line 18-39 claims 1-5 figures 1,2  ---  -/--	1, 27, 33, 38		
<input checked="" type="checkbox"/> Further documents are listed in the continuation of box C.				
<input checked="" type="checkbox"/> Patent family members are listed in annex.				
<sup>o</sup> Special categories of cited documents :				
<table style="width: 100%; border: none;"> <tr> <td style="width: 50%; border: none; vertical-align: top;">                     "A" document defining the general state of the art which is not considered to be of particular relevance                      "E" earlier document but published on or after the international filing date                      "L" document which may throw doubts on priority claim(s) or which is cited to establish the publication date of another citation or other special reason (as specified)                      "O" document referring to an oral disclosure, use, exhibition or other means                      "P" document published prior to the international filing date but later than the priority date claimed                 </td> <td style="width: 50%; border: none; vertical-align: top;">                     "T" later document published after the international filing date or priority date and not in conflict with the application but cited to understand the principle or theory underlying the invention                      "X" document of particular relevance; the claimed invention cannot be considered novel or cannot be considered to involve an inventive step when the document is taken alone                      "Y" document of particular relevance; the claimed invention cannot be considered to involve an inventive step when the document is combined with one or more other such documents, such combination being obvious to a person skilled in the art.                      "&amp;" document member of the same patent family                 </td> </tr> </table>			"A" document defining the general state of the art which is not considered to be of particular relevance "E" earlier document but published on or after the international filing date "L" document which may throw doubts on priority claim(s) or which is cited to establish the publication date of another citation or other special reason (as specified) "O" document referring to an oral disclosure, use, exhibition or other means "P" document published prior to the international filing date but later than the priority date claimed	"T" later document published after the international filing date or priority date and not in conflict with the application but cited to understand the principle or theory underlying the invention "X" document of particular relevance; the claimed invention cannot be considered novel or cannot be considered to involve an inventive step when the document is taken alone "Y" document of particular relevance; the claimed invention cannot be considered to involve an inventive step when the document is combined with one or more other such documents, such combination being obvious to a person skilled in the art. "&" document member of the same patent family
"A" document defining the general state of the art which is not considered to be of particular relevance "E" earlier document but published on or after the international filing date "L" document which may throw doubts on priority claim(s) or which is cited to establish the publication date of another citation or other special reason (as specified) "O" document referring to an oral disclosure, use, exhibition or other means "P" document published prior to the international filing date but later than the priority date claimed	"T" later document published after the international filing date or priority date and not in conflict with the application but cited to understand the principle or theory underlying the invention "X" document of particular relevance; the claimed invention cannot be considered novel or cannot be considered to involve an inventive step when the document is taken alone "Y" document of particular relevance; the claimed invention cannot be considered to involve an inventive step when the document is combined with one or more other such documents, such combination being obvious to a person skilled in the art. "&" document member of the same patent family			
Date of the actual completion of the international search  <p style="text-align: center;">26 January 2000</p>		Date of mailing of the international search report  <p style="text-align: center;">08/02/2000</p>		
Name and mailing address of the ISA European Patent Office, P.B. 5818 Patentlaan 2 NL - 2280 HV Rijswijk Tel. (+31-70) 340-2040, Tx. 31 651 epo nl, Fax: (+31-70) 340-3016		Authorized officer  <p style="text-align: center;">Yang, Y</p>		

Form PCT/ISA/210 (second sheet) (July 1992)



**INTERNATIONAL SEARCH REPORT**

International Application No  
PCT/EP 99/03440

C.(Continuation) DOCUMENTS CONSIDERED TO BE RELEVANT		
Category	Citation of document, with indication, where appropriate, of the relevant passages	Relevant to claim No.
A	H. ANDOH; M. SAWAHASHI; F. ADACHI: "Channel Estimation Using Time Multiplexed Pilot Symbols for Coherent Rake Combining for DS-CDMA Mobile Radio" PERSONAL, INDOOR AND MOBILE RADIO COMMUNICATIONS, 8TH IEEE INTL SYMPOSIUM, 'Online! vol. 3, 1 - 4 September 1997, pages 954-958, XP002128851 Retrieved from the Internet: <URL:http://iel.ihs.com> 'retrieved on 2000-01-26! page 954, column 1, paragraph 1 -page 955, column 1, paragraph 1 figures 1,2 -----	1,27,33, 38
A	GB 2 324 932 A (MOTOROLA LTD) 4 November 1998 (1998-11-04) abstract claim 1 figure 6 -----	1,27,33, 38

1

# INTERNATIONAL SEARCH REPORT

information on patent family members

International Application No

PCT/EP 99/03440

Patent document cited in search report	Publication date	Patent family member(s)	Publication date
EP 0755127 A	22-01-1997	JP 2785812 B	13-08-1998
		JP 9238098 A	09-09-1997
		US 5886987 A	23-03-1999
-----			
GB 2324932 A	04-11-1998	AU 7648998 A	27-11-1998
		WO 9851048 A	12-11-1998
		EP 0922350 A	16-06-1999
-----			

Form PCT/ISA/210 (patent family annex) (July 1992)

(19) World Intellectual Property Organization  
International Bureau



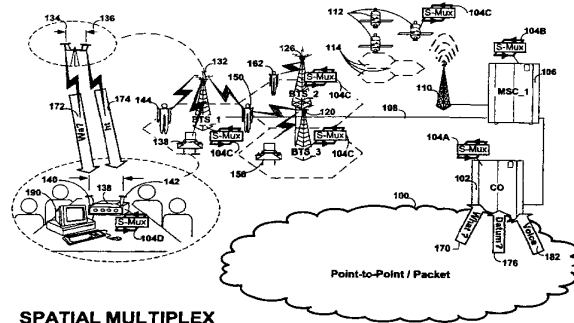
(43) International Publication Date  
8 February 2001 (08.02.2001)

PCT

(10) International Publication Number  
WO 01/10156 A1

- (51) International Patent Classification<sup>7</sup>: H04Q 7/36, (74) Agent: VILLENEUVE, Joseph, M.; Beyer Weaver & Thomas, LLP, P.O. Box 130, Mountain View, CA 94042-0130 (US).  
H04B 7/005
- (21) International Application Number: PCT/US00/20706
- (22) International Filing Date: 28 July 2000 (28.07.2000)
- (25) Filing Language: English
- (26) Publication Language: English
- (30) Priority Data:  
09/364,146 30 July 1999 (30.07.1999) US  
09/545,434 7 April 2000 (07.04.2000) US  
09/564,770 3 May 2000 (03.05.2000) US
- (71) Applicant: GIGABIT WIRELESS, INC. [US/US]; 3099 N. First Street, San Jose, CA 95134 (US).
- (81) Designated States (national): AE, AG, AL, AM, AT, AU, AZ, BA, BB, BG, BR, BY, BZ, CA, CH, CN, CR, CU, CZ, DE, DK, DM, DZ, EE, ES, FI, GB, GD, GE, GH, GM, HR, HU, ID, IL, IN, IS, JP, KE, KG, KP, KR, KZ, LC, LK, LR, LS, LT, LU, LV, MA, MD, MG, MK, MN, MW, MX, MZ, NO, NZ, PL, PT, RO, RU, SD, SE, SG, SI, SK, SL, TJ, TM, TR, TT, TZ, UA, UG, UZ, VN, YU, ZA, ZW.
- (84) Designated States (regional): ARIPO patent (GH, GM, KE, LS, MW, MZ, SD, SL, SZ, TZ, UG, ZW), Eurasian patent (AM, AZ, BY, KG, KZ, MD, RU, TJ, TM), European patent (AT, BE, CH, CY, DE, DK, ES, FI, FR, GB, GR, IE, IT, LU, MC, NL, PT, SE), OAPI patent (BF, BJ, CF, CG, CI, CM, GA, GN, GW, ML, MR, NE, SN, TD, TG).
- (72) Inventors: PAULRAJ, Arogyaswami, J.; 59 Peter Coultts Hill, Stanford, CA 94305 (US). HEATH, Robert, W., Jr.; 1875 Capistrano Way, Los Altos, CA 94024 (US). SEBASTIAN, Peroor, K.; 262 Higdon Avenue, #4, Mountain View, CA 94041 (US). GESBERT, David, J.; 180 Beatrice Street, Mountain View, CA 94041 (US). CHOPRA, Rahul; 1180 Fewtrell Street, Campbell, CA 95008 (US).
- Published:  
— With international search report.
- For two-letter codes and other abbreviations, refer to the "Guidance Notes on Codes and Abbreviations" appearing at the beginning of each regular issue of the PCT Gazette.

(54) Title: SPATIAL MULTIPLEXING IN A CELLULAR NETWORK



WO 01/10156 A1

(57) Abstract: The present invention provides methods and apparatus for implementing spatial multiplexing in conjunction with the one or more multiple access protocols during the broadcast of information in a wireless network. A wireless cellular network for transmitting subscriber datastream(s) to corresponding ones among a plurality of subscriber units located within the cellular network is disclosed. The wireless cellular network includes base stations and a logic. The base stations each include spatially separate transmitters for transmitting, in response to control signals, selected substreams of each subscriber datastream on an assigned channel of a multiple access protocol. The logic assigns an available channel on which to transmit each subscriber datastream. The logic routes at least a substream of each datastream to at least a selected one of the base stations. The logic also generates control signals to configure the at least a selected one of the base stations to transmit the selected substreams to a corresponding one among the plurality of subscriber units on the assigned channel. A subscriber unit for use in a cellular system is also disclosed. The subscriber unit includes a plurality of spatially separate antennas and a transmitter for transmitting a plurality of substreams of a datastream on an assigned channel or slot of a multiple access protocol. The transmitter is arranged to apply each substream to an associated one of the spatially separate antennas.

## SPATIAL MULTIPLEXING IN A CELLULAR NETWORK

## BACKGROUND OF THE INVENTION

## 1. Field of Invention

5 The field of the present invention relates in general to the field of wireless broadcast of information using one or more multiple access protocols and in particular to methods and apparatus for implementing spatial multiplexing in conjunction with the one or more multiple access protocols during the broadcast of information.

## 10 2. Description of the Related Art

In wireless broadcast systems, information generated by a source is transmitted by wireless means to a plurality of receivers within a particular service area. The transmission of such information requires a finite amount of bandwidth, and in current state of the art transmission of information from different sources, must  
15 occur in different channels.

Since there are quite a few services (e.g. television, FM radio, private and public mobile communications, etc.) competing for a finite amount of available spectrum, the amount of spectrum which can be allocated to each channel is severely limited. Innovative means for using the available spectrum more efficiently are of  
20 great value. In current state of the art systems, such as cellular telephone or broadcast television, a suitably modulated signal is transmitted from a single base station centrally located in the service area or cell and propagated to receiving stations in the service area surrounding the transmitter. The information transmission rate achievable by such broadcast transmission is constrained by the allocated bandwidth.  
25 Due to attenuation suffered by signals in wireless propagation, the same frequency channel can be re-used in a different geographical service area or cell. Allowable interference levels determine the minimum separation between base stations using the same channels. What is needed is a way to improve data transfer speed in the

multiple access environments currently utilized for wireless communications within the constraints of available bandwidth.

#### SUMMARY OF THE INVENTION

5           The present invention provides methods and apparatus for implementing spatial multiplexing in wireless networks such as cellular networks. In various embodiments unique network configuration, base stations and remote (subscriber) units are described. A wide variety of different applications of spatial multiplexing are also described.

10           In some embodiments the wireless cellular network includes base stations having spatially separate transmitters for transmitting in response to control signals and selected substreams of each subscriber datastream on an assigned channel of a multiple access protocol. From the standpoint of the network, the spatially separate transmitters can be located at a single base station or may be located on multiple base  
15           stations. Logic assigns an available channel on which to transmit each subscriber datastream. The logic routes at least a substream of each datastream to at least a selected one of the base stations. The logic also generates control signals to configure at least a selected one of the base stations to transmit the selected substreams to a corresponding one among the plurality of subscriber units on the assigned channel.  
20           Appropriate receivers are also described.

          In other embodiments of the invention, subscriber units for use in cellular systems are disclosed. The subscriber units typically will have both spatially separate transmitters and receivers, although that is not a fixed requirement. In some  
25           embodiments subscriber unit includes spatially separate receivers, a spatial processor, and a combiner. The spatially separate receivers receive the assigned channel composite signals resulting from the spatially separate transmission of the subscriber downlink datastream(s). The spatial processor is configurable in response to a control signal transmitted by the base station to separate the composite signals into estimated  
30           substreams based on information obtained during the transmission of known data patterns from at least one of the base stations or by using blind training techniques. The spatial processor signals the base stations when a change of a spatial transmission configuration is required in order to resolve the composite signals into estimated

downlink datastream(s). The combiner combines the estimated substreams into a corresponding subscriber datastream.

## BRIEF DESCRIPTION OF THE DRAWINGS

These and other features and advantages of the present invention will become more apparent to those skilled in the art from the following detailed description in  
5 conjunction with the appended drawings in which:

FIG. 1 shows a wireless cellular network incorporating spatial multiplexing and multiple access according to the current invention.

FIG. 1B is a detailed view of selected cells within the cellular network shown in FIG. 1A.

10 FIG. 1C shows a cell architecture that provides overlapping regions suitable for multi-base spatial multiplexing.

FIGS. 2A-G show alternate embodiments for the subscriber units utilized in the wireless cellular network shown in FIGS. 1A-B.

15 FIG. 3A shows a detailed hardware block diagram of a single base station and subscriber unit for use in the wireless cellular network shown in FIGS. 1A-B.

FIG. 3B shows a detailed hardware block diagram of a single base station and subscriber unit as in Fig. 3A, wherein the subscriber unit interfaces with a local area network.

20 FIGS. 4A-J show detailed hardware block diagrams of the multiple access hardware for controlling the transmission of subscriber datastream(s) from one or more of the base stations within the wireless network.

FIGS. 5A-B show detailed hardware block diagrams of the hardware associated with the receipt of multiple subscriber datastream(s) at the base stations of the wireless network of the current invention.

25 FIG. 6 shows a detailed view of the signals and the symbols associated with the transmission and receipt of spatially multiplexed signals according to an embodiment of the current invention.

30 FIGS. 7A-B show detailed hardware block diagrams of the configurable spatial processor associated with the receiver circuitry receiver, according to an embodiment of the current invention.

FIGS. 7C-D show detailed hardware block diagrams of a configurable space and space-time processor associated with the configurable spatial receiver according to an embodiment of the current invention.

5 FIG. 8 shows in-band training and data signals for calibrating the spatially configurable receiver during the transmission of spatially multiplexed data, according to an embodiment of the current invention.

FIGS. 9A-B are respectively detailed hardware block diagrams of a spatially multiplexed transmitter and receiver implementing a time-division multiple access protocol (TDMA), according to an embodiment of the current invention.

10 FIGS. 10A-B are respectively detailed hardware block diagrams of a spatially multiplexed transmitter and receiver implementing a frequency-division multiple access protocol (FDMA), according to an embodiment of the current invention.

15 FIGS. 11A-B are respectively detailed hardware block diagrams of a spatially multiplexed transmitter and receiver implementing a code-division multiple access protocol (CDMA), according to an embodiment of the current invention.

FIGS. 12A-B are respectively detailed hardware block diagrams of a spatially multiplexed transmitter and receiver implementing a space-division multiple access protocol (SDMA), according to an embodiment of the current invention.

20 FIGS. 13A-B are process flow diagrams showing the acts associated with respectively the spatially multiplexed transmission and reception of datastream(s) in any one of a number of multiple access protocols, according to an embodiment of the invention.

FIG. 14 is a diagrammatic illustration of a hybrid DSL/wireless link that incorporates a spatially multiplexed remote wireless device.

25 FIG. 15 is a diagrammatic illustration of a hybrid cable/wireless link that incorporates a spatially multiplexed remote wireless device in a network access unit.

FIG. 16 is a diagrammatic illustration of a repeater BTS that utilizes a spatially multiplexed remote wireless device.

#### DETAILED DESCRIPTION OF THE EMBODIMENTS



A method and apparatus is disclosed which allows for both spatial multiplexed and non-spatial wireless communications between portable units and corresponding selected ones among a plurality of base stations. The methods and apparatus of the current invention may be implemented on a dedicated wireless infrastructure or may  
5 be superimposed on existing wireless communications systems, such as cellular telephone and paging services, which are currently in place around the world. The methods and apparatus include implementation in any of a number of multiple access protocols.

#### Spatial Multiplexing and Multiple Access

10 Spatial multiplexing (SM) is a transmission technology which exploits multiple antennas at both the base station(s) and at the subscriber units to increase the bit rate in a wireless radio link with no additional power or bandwidth consumption. Under certain conditions, spatial multiplexing offers a linear increase in spectrum efficiency with the number of antennas. Assuming, for example,  $N=3$  antennas are  
15 used at the transmitter and receiver, the stream of possibly coded information symbols is split into three independent substreams. These substreams occupy the same channel of a multiple access (MA) protocol, the same time slot in a time-division multiple access (TDMA) protocol, the same frequency slot in frequency-division multiple access (FDMA) protocol, the same code/key sequence in code-division  
20 multiple access (CDMA) protocol or the same spatial target location in space-division multiple access (SDMA) protocol. The substreams are applied separately to the  $N$  transmit antennas and launched into the radio channel. Due to the presence of various scattering objects (buildings, cars, hills, etc.) in the environment, each signal experiences multipath propagation. The composite signals resulting from the  
25 transmission are finally captured by an array of receive antennas with random phase and amplitudes. For every substream the set of  $N$  received phases and  $N$  received amplitudes constitute its spatial signature.

At the receive array, the spatial signature of each of the  $N$  signals is estimated. Based on this information, a signal processing technique is then applied to separate  
30 the signals, recover the original substreams and finally merge the symbols back together. Linear or nonlinear receivers can be used providing a range of performance and complexity trade-offs. A linear spatial multiplexing receiver can be viewed as a

bank of superposed spatial weighting filters, where every filter aims at extracting one of the multiplexed substreams by spatially nulling the remaining ones. This assumes, of course, that the substreams have different signatures.

If the transmitter is equipped with  $M$  antennas, while the receiver has  $N$  antennas, the rate improvement factor allowed by spatial multiplexing is the minimum of these two numbers. Additional antennas on the transmit or receive side are then used for diversity purposes and further improve the link reliability by improving, for example, the signal-to-noise ratio or allowing for smaller fading margins, etc. Effectively spatial multiplexing allows a transmitter receiver pair to communicate in parallel through a single MA channel, hence allowing for a possible  $N$ -fold improvement of the link speed. More improvement is actually obtained if we take into account the diversity gain offered by the multiple antennas (for instance, in a Rayleigh fading channel). Such performance factors are derived ideally under the assumption that the spatial signatures of the substreams are truly independent from each other. In reality, the level of independence between the signatures will determine the actual link performance. The performance, however, usually exceeds that obtained by a single antenna at the transmitter and receiver. For example, at two GHz, assuming the base station and the subscriber unit are spaced apart by one mile and using three antennas at each end of the link, a scattering radius of about 30 feet (both ends) is enough to achieve maximum performance.

FIG. 1A shows a plurality of subscriber units wirelessly coupled over a cellular network to a network 100. Network 100 may include: a local area network (LAN), a wide area network (WAN), a public switched telephone network (PSTN), Public Land Mobile Network (PLMN), an adhoc network, a virtual private network, an intranet or the internet. The wireless system includes: a central office (CO) 102, a master switch center (MSC) 106, a ground based relay station 110, satellites (112), base stations 120, 126 and 132 (BTS) and subscriber units 156, 138, 144, 150 and 162. The subscriber units may be mobile, fixed or portable. The base stations may be fixed or mobile. The base stations may include: a tower, satellites, balloons, planes, etc. The base station may be located indoors/outdoors. The cellular network includes one or more base stations, where each base station includes one or more spatially separate transmitters.

The central office 102 is coupled to the network 100. Network 100 may be circuit switched (e.g. point-to-point) or packet switched network. The central office is coupled to a master switching center 106. The MSC in traditional cellular systems is alternately identified as: a mobile telephone switching office (MTSO) by Bell Labs, an electronic mobile Xchange (EMX) by Motorola, an AEX by Ericsson, NEAX by NEC, a switching mobile center (SMC) and a master mobile center (MMC) by Novatel. The MSC is coupled via data/control line 108 to the satellites via relay station 110 and to the base stations. In an alternate embodiment of the invention, base station controllers (BSC) may serve as intermediary coupling points between the MSC and the base stations. In the embodiment shown, each of the BTS includes an array of spatially separate antennas for transmission and/or reception. The BTS may also include traditional antenna for whichever of the receive/transmit side of its communication capability lacks spatially separate antenna and associated circuitry. Antennas of a transmitter/receiver are defined to be spatially separate if they are capable of transmitting/receiving spatially separate signals. Physically separate antenna may be used to transmit/receive spatially separate signals. Additionally, a single antenna may be used to transmit/receive spatially separate signals provided it includes the ability to transmit/receive orthogonal radiation patterns. Hereinafter, the phrase "spatially separate" shall be understood to include any antenna or transmitter or receiver capable of communicating spatially separate signals. The base stations are configured to communicate with subscriber units of a traditional type, i.e. those lacking either spatially separate transmission/reception as well as spatially enabled subscriber units, i.e. those including either or both spatially separate reception and transmission capabilities.

In operation, distinct subscriber datastream(s) 170, 176 and 182 are received by CO 102. The CO performs the initial routing of the data streams to the appropriate one of a plurality of MSCs which may be located across the country. The MSC performs several functions. It controls the switching between the PSTN or network 100 and the BTSs for all wireline-to-subscriber, subscriber-to-wireline and subscriber-to-subscriber calls. It processes/logic data received from BTSs concerning subscriber unit status, diagnostic data and bill compiling information. In an embodiment of the invention, the MSC communicates with the base stations and/or satellites with a datalink using the X.25 protocol or IP protocol. The MSC also implements a portion

of the spatial multiplexing and multiple access processes/logic (SM\_MA) 104B of the current invention. Each BTS operates under the direction of the MSC. The BTS and satellites 112 manage the channels at the site, supervise calls, turn the transmitter/receiver on/off, inject data onto the control and user channels and perform diagnostic tests on the cell-site equipment. Each BTS and satellite also implement a portion of the SM\_MA processes/logic 104C. The subscriber units may be both traditional and spatially enabled and may still communicate over the system. Those subscriber units that are spatially enabled on either/both the transmit/receive side of communications implement SM\_MA processes/logic 104D as well.

10           The SM\_MA processes/logic allow high bit rate communications with any of the SM\_MA enabled subscriber units within existing bandwidth constraints and within any of the multiple access (MA) protocols common to wireless communications or combinations thereof. Those MA protocols include: time-division multiple access (TDMA), frequency-division multiple access (FDMA), code-division multiple access (CDMA), space-division multiple access (SDMA) and many other multiple access protocols known to those skilled in the art. The SM\_MA processes/logic include the ability to selectively allocate spatially separate downlink or uplink capability to any spatially enabled subscriber within a multiple access environment. This capability allows, as to that subscriber, the elevation of bit rates well above those currently available. Thus, a whole new range of subscribers can be anticipated to take advantage of this capability. Utilizing this invention, it will be possible to provide a wireless medium for connecting workstations, servers and tele-video conferences using the existing cellular infrastructure with the adaptations provided by this invention. The SM\_MA processes/logic involve splitting subscriber datastream(s) destined for spatial multiplexing into substreams and intelligently routing and re-routing the substreams during a call session so as to maintain consistent quality of service (QoS). The substreams are communicated on the same channel using the same access protocol, thus not requiring additional resources or bandwidth to implement. The processes/logic include: access protocol assignment, channel assignment, monitoring of spatial separation, determination/re-determination of spatial signatures for each communication link, routing/re-routing between single-BTS and multi-BTS, handoff and control of substream parsing/combining.

In FIG. 1A, datastream(s) 170, 176 and 182 are shown originating on network 100. The SM\_MA processes/logic 104 have parsed and routed subscriber data stream 170 into substreams 172-174, which are transmitted on a single channel of a multiple access protocol over the spatially separate antenna 134-136 of BTS 132. Subscriber unit 138, via spatially separate antenna 140-142, receives composite signals 172-174  
5 resulting from the substream transmission and utilizing SM\_MA processes/logic 104D, derives the substream and original datastream 170 therefrom. In the embodiment shown, the data is delivered to the computer 190 to which the fixed subscriber desktop unit 138 is coupled. The cellular environment may also be  
10 implemented utilizing aerial equivalents of the base stations. In the embodiment shown, a plurality of satellites 112 generally deliver subscriber datastream(s) via spatially separate antennae on each of the satellites to a cellular network, i.e. 114.

In a circuit-switched embodiment of the invention, a call over a cellular network may require using two channels simultaneously; one called the user channel and one called the control channel. The BTS(s) transmit and receive on what is called  
15 a forward/downlink control channel and the forward/downlink voice/data channel and the subscriber unit transmit/receive on the reverse/ uplink control and voice/data channels. Completing a call within a cellular radio system is quite similar to the PSTN. When a subscriber unit is first turned on, it performs a series of startup  
20 procedures and then samples the received signal strength on all user channels. The unit automatically tunes to the channel with the strongest receive signal strength and synchronizes to the control data transmitted by the BTS(s). The subscriber unit interprets the data and continues monitoring the controlled channels. The subscriber unit automatically re-scans periodically to ensure that it is using the best control  
25 channel. Within a cellular system, calls can take place between a wireline party and a subscriber unit or between two subscriber units. For wireline-to-subscriber unit calls, the MSC receives a call from either a wireline party or in the form of a call setup packet from the network 100. The MSC determines whether the subscriber unit to which the call is destined is on/off hook. If the subscriber unit is available, the MSC  
30 directs the appropriate BTS to page the subscriber unit. The subscriber unit responds to the BTS indicating its availability and spatial multiplexing capabilities, receive and/or transmit. Following the page response from the subscriber unit, the MSC/BTS switch assigns an idle channel, configures spatial processing capability on both the

subscriber unit and BTS(s) if appropriate, and instructs the subscriber unit to tune to that channel. The subscriber unit sends a verification of channel tuning to the BTS(s) and then sends an audible call progress tone to the subscriber I/O unit causing it to ring. The switch terminates the call progress tone when it receives positive indication  
5 the subscriber has answered and the conversation or communication has begun.

Calls between two subscriber units are also possible in the cellular radio system. To originate a call to another subscriber unit, the calling party enters the called number into the unit's memory via the touch pad and then presses the send key. The MSC receives the caller's identification number and the called number then  
10 determines if the called unit is free to receive the call. The MSC switch sends a page command to all base stations and the called party, who may be anywhere in the service area, receives the page. The MSC determines the spatial multiplexing capability of both subscribers. Following a positive page from the called party, the switch assigns each party an idle user channel and instructs each party to tune into  
15 that respective channel. Then the called party's phone rings. When the system receives notice the called party has answered the phone, the switch terminates the call progress tone and a communication can begin between two subscriber units. If spatial multiplexing is enabled, the communication link will include that capability.

One of the most important features of the cellular system is its ability to  
20 transfer calls that are already in progress from one cell site/base station to another as a subscriber unit moves from cell to cell or coverage area to coverage area within the cellular network. This transfer process is called a handoff. Computers at the BTS transfer calls from cell to cell with minimal disruption and no degradation in quality of transmission. The handoff decision algorithm is based on variations in signal  
25 strength. When a call is in progress, the MSC monitors the received signal strength of each user channel. If the signal level on an occupied channel drops below a predetermined threshold for more than a given time interval, the switch performs a handoff provided there is a vacant channel. In a traditional non-SM cellular system a traditional handoff involves switching the transmission point of a subscriber session  
30 (datastream) from one BTS to another. In the current invention various types of handoff, e.g. partial and full may take place. The handoff operation may involve the MSC re-routing the call and the entire datastream or selected substreams thereof to different antennas of the same BTS or to a new BTS/BTSs in whole or in part. Where

the re-routing is partial, at least one substream communication path is left unchanged while other of the substreams are re-routed to antennas on another BTSs. Where the handoff is full the multiple substreams transmitted from one or more BTSs are re-routed to other BTS(s).

5           In an embodiment of the invention utilizing a packet switched architecture, call setup may be implemented using protocols including: ALOHA, slotted-ALOHA, carrier sense multiple access (CSMA), TDMA, FDMA, CDMA, SDMA, etc., or any combination thereof.

          BTS 132, in the embodiment shown, includes spatially separate antenna array.  
10       There may be any number of antennas. In some spatial environments, baud rates for spatially multiplexed communications on a single channel will increase linearly with the number of antennas allocated by subscriber unit and BTSs to a call session. In the embodiment shown, each BTSs array includes at least two antennas 134 and 136. The BTS may include either or both spatial multiplexing capability on the downlink  
15       (transmit) or uplink (receive) side. In the embodiment shown, each BTS includes spatial multiplexing capability on both the downlink and uplink. Although each of the following embodiments utilizes two antennas to implement SM, any number of antennas on a single BTS or multiple BTSs may be utilized without departing from the scope of the invention.

20           FIG. 1B shows a more detailed view of the BTS and subscriber units shown in FIG. 1A. Each BTS includes two spatially separate antennas. BTS 120 includes antennas 122-124. BTS 126 includes antennas 128-130. BTS 132 includes antennas 134-136. In the embodiment shown, many of the subscriber units also include at least two spatially separate antennas. Subscriber unit 150 includes spatially separate  
25       antennas 152-154. In the embodiment shown, the MSC handles the routing of subscriber datastream(s) 170, 176 and 182 from network 100 to the appropriate BTSs for transmission to the appropriate subscriber unit. In an embodiment of the invention, the SM\_MA processes/logic include the ability to determine whether to implement or not implement spatial multiplexing (SM), based on either the  
30       presence/absence of SM capabilities in the corresponding subscriber unit and/or on the nature of the datastream. If, for example, the subscriber lacks SM capability on either or both the uplink/downlink, then the corresponding datastream will not be

parsed into substreams. Alternately, even if the subscriber unit and BTS have SM capability on both downlink and uplink, certain types of datastream(s) may not require SM processing. Examples of these might include: traditional voice call sessions, call sessions which require only low QoS or datastream(s) which require only very low bit rates or are susceptible to buffering and delayed transmission.

In the example shown in FIG. 1B, datastream 182 is traditional mode traffic, e.g. a subscriber telephone call between an upstream subscriber and the subscriber unit 144. Subscriber unit 144 is located within a cell serviced by BTS 132. Under the control of MSC 106, the datastream 182 is transmitted over signal line 108 directly to the corresponding base station 132 without being split or parsed into associated substreams. In the example shown, datastream(s) 182 is transmitted from a single antenna, e.g. antenna 134, without any SM techniques. That transmission is received by the subscriber unit 144. As discussed above, subscriber unit 144 may be a traditional cell phone lacking SM capability. Alternately, subscriber unit 144 may be SM enabled but, nevertheless, receives the call in traditional mode after appropriately configuring itself to opt out of SM receive side processes/logic, electing instead traditional mode.

In the example shown, datastream(s) 170 is handled using SM\_MA processes/logic 104\_. The datastream 170 and/or substreams thereof, depending on the embodiment, is routed by the MSC to BTS 132. The processes/logic 104 provide to each antenna 134-136 of BTS 132 a single substream derived from the original datastream 170, on a common channel within the appropriate access protocol. Those substreams are received as composite signals by the spatially separate antenna 140-142 (see FIG. 2B) of subscriber unit 138. The subscriber unit 138, utilizing SM-MA processes/logic 104D, derives the substreams from the composite signals and combines these into the initially transmitted datastream(s) 170.

Datastream(s) 176 is also subject to SM\_MA processes/logic 104\_. The datastream 176 and/or substreams thereof, depending on the embodiment, is routed by the MSC, initially to BTS 132 for single-base transmission to subscriber unit 150. SM-MA processes/logic implemented collectively at the MSC 106 and BTS 132 result in the splitting/parsing of the datastream(s) 176 into substreams 178-180. Initially those substreams are received as composite signals by the spatially separate



antenna 152-154 (see FIG. 2C) of subscriber unit 150. The subscriber unit 150, utilizing SM\_MA processes/logic 104D, derives the substreams from the composite signals and combines these into the initially transmitted datastream(s) 176.

5 Implementing SM or SM\_MA communications between the BTS and the associated subscriber unit may be either line-of-site (LOS) or multipath. Multipath communications are likely in environments, such as a city, where buildings and other objects deflect signals transmitted from the BTS many times before their arrival at the subscriber unit. Under certain conditions, it may be the case that transmissions originating from spatially separate antennas of a single BTS may arrive at a subscriber  
10 unit along signal paths which cannot be spatially separated by the antenna array on the subscriber unit. Where this is the case, it may be necessary for the processes/logic to reconfigure the spatial transmission characteristics of the substreams so that they may be received at the corresponding portable unit in a manner which is spatially separable. In the example shown, the substreams 180 and 178\_S are transmitted  
15 initially from a single BTS 132. When a determination is made, either by the BTS or subscriber unit that separation of the substreams is not possible, a spatial reconfiguration is initiated by the spatial multiplexing processes/logic 104. The determination might, for example, result from the subscriber unit signaling the BTS or from the BTS determining that the bit error rate (BER) of the transmission exceeded  
20 an acceptable level. In an alternate embodiment of the invention in which base and subscriber communicate over a common channel, the signaling from the subscriber to the base station(s) for a change of a spatial transmission configuration is simplified. The BTS may, by analyzing the received signals, determine that they can not be adequately separated and in response, alter the spatial configuration of the  
25 transmissions to the subscriber unit with which it shares a channel. In the example shown, this reconfiguration results in a change of spatial configuration to multi-base transmission. Substream 178\_M is re-routed through BTS 120 and specifically antenna 122. Because subscriber unit 150 is positioned in an area in which the transmissions from BTS 120 and 132 overlap, the change in spatial configuration is  
30 possible. The increased spatial separation on the transmit side increases likelihood that the substreams can be spatially separated by the subscriber unit 150 and its associated SM-MA processes/logic 104D.

FIG. 1C shows another embodiment of the current invention in which a cell architecture which provides overlapping regions suitable for multi-base spatial multiplexing is shown. As in normal cellular structure, co-channel interference is avoided by ensuring that cells operating in the same frequency are spaced apart. In the example shown, BTSs 186A-C form an overlapping region between them in which they are shown in spatially multiplexed communication with subscriber unit 138. BTSs 186C-E form an overlapping region between them, in which they are shown in spatially multiplexed communication with subscriber unit 150A. BTSs 186C, F-G also form an overlapping region between them, in which they are shown in spatially multiplexed communication with subscriber unit 150B. The communications with subscriber units 138, 150A-B are conducted on separate channels to avoid co-channel interference. Diversity techniques can be simultaneously implemented. More distant cells may re-use the same channels provided co-channel interference is tolerable.

FIGS. 2A-G show alternate embodiments of subscriber units which may be either fixed, portable or mobile. FIG. 2A shows a mobile cellular phone 144 with a single antenna 146. In an embodiment of the invention, the single antenna includes the capability of transmitting and/or receiving spatially separable signals utilizing orthogonal di-poles. In an alternate embodiment of the invention, subscriber unit 144 is a traditional cellular phone which does not have the capability of transmitting/receiving a spatially separable signal. Either embodiment may be compatible with the system shown in FIGS. 1A-B, provided that system includes an embodiment of the invention with the ability to detect the transceiver capabilities of the subscriber units and to configure communications between that unit and the corresponding BTS accordingly.

FIG. 2B shows a fixed subscriber unit 138 coupled to a computer 190. In this embodiment, high-speed data communications between computer 190 and a wireless communication network with spatial multiplexing capabilities is enabled by fixed subscriber unit 138. Fixed subscriber unit 138 is shown with an antenna array including antennas 140-142. In the embodiment shown, additional antennas are provided. These may be utilized either for spatial multiplexing or to implement receive/transmit processing, e.g. diversity techniques, beam forming, interference cancellation, etc., the latter for the purpose of improving communication quality and

link budget. The current state of the art requires a minimum separation between antennas 140-142, i.e. D1 equivalent to 1/2 the carrier wavelength. Further improvements in signal processing may avoid this requirement.

FIG. 2C shows a mobile subscriber unit, i.e. a cellular telephone 150,  
5 reconfigured for implementation of SM or SM\_MA on either or both of the transmit (uplink) or receive (downlink) side of its communication with the BTSs. To this end, the antennas 152-154 are provided.

FIG. 2D shows a personal digital assistant (PDA) 200 and associated docking station 202 configured to implement SM or SM\_MA communications on either or  
10 both the transmit and receive portions of its communications. To this end, the antenna array, which in the embodiment shown, includes two antennas 204-206 is provided. An example of personal digital assistants currently on the market that could be configured to utilize the current invention is the Palm Pilot™ product sold by 3Com Corporation.

FIG. 2E shows a mobile subscriber unit 210 implemented as part of an  
15 automobile 216. The antenna array associated with this unit is not shown. The use of SM or SM\_MA wireless communications between vehicles and base stations can provide such benefits as vehicle navigation, routing, and diagnostics.

FIG. 2F shows a notebook computer 220 configured for SM or SM\_MA  
20 communication utilizing an antenna array with antennas 222-224 and associated hardware and processes/logic.

FIG. 2G shows a fixed subscriber unit 138 incorporated into a wireless router or bridge 235, which is coupled to a wired network 240. In this embodiment, the subscriber unit 138 serves as a high speed wireless connection between the wired  
25 network and the wireless communication network. The network 240 can take any suitable form including a local area network, a wide area network, an intranet, etc. It should be appreciated that in this arrangement, a wireless link is simply being used to connect two networks and such wireless links can be used in a wide variety of applications. For example, the wireless link can be used to provide high speed  
30 Internet access to the network 240. In the embodiment shown, the fixed subscriber unit 138 is shown as being incorporated into a router or bridge 235. However, it should be appreciated that the subscriber unit can readily be incorporated into a

variety of network components having a variety of functionalities. For example, the router or bridge can further include firewall capabilities, etc.

FIG. 3A is a detailed hardware block diagram of a subscriber unit 138 and a BTS 132. The BTS 132 includes: a multiple access spatial transmitter 310, a multiple access spatial receiver 330, a controller module 320 and upstream processes/logic 300, further details of which are provided in the accompanying FIGS. 4-5. The subscriber unit 138 includes: a multiple access spatially configured receiver 380, a multiple access spatially configured transmitter 350 and a control unit 370. The multiple access spatial transmitter 310 includes: a selector 312, a final transmission stage 316 and optionally may include transmit processes/logic 314. The final stage transmitter 316 is coupled to a spatially separate antenna array which includes antennas 134T-136T.

In operation, the subscriber datastream(s) and/or substreams thereof are provided to the selector 312 from the upstream processes/logic 300. Utilizing either in band or out of band control signals embodied in the datastream(s)/substreams themselves or separately communicated from the SM\_MA processes/logic at the MSC 106 or elsewhere, the selector implements the MA protocol utilized by the wireless network. That protocol, as discussed above, may include: TDMA, FDMA, CDMA or SDMA, for example. The selector places each of the datastream(s)/substreams on the appropriate channel. Each of the datastream(s)/substreams are then passed through the optional transmit processes/logic, in which any of a number of well-known prior art signal processing techniques may be implemented to improve the quality of transmission. These techniques include, but are not limited to, diversity processing, space coding, space-time coding, space-frequency coding, and beam forming and interference canceling. The datastream(s)/substreams are then passed to the final transmit stage 316. Traditional mode traffic may be routed by the SM\_MA processes/logic 104 to the appropriate antenna 134T-136T for transmission. If diversity processing is implemented, even traditional mode traffic may be transmitted using multiple antennas. Spatial mode traffic, i.e. the individual substreams thereof, will be routed to the appropriate one of the two antennas 134T-136T.

On the receive side, the subscriber unit SM\_MA configurable receiver 380 includes: receiver first stage 382, optional receive processes/logic 384, spatial/space-

time processor 386, decoder 388, combiner 390 and I/O module 392. The receiver first stage is coupled to a spatially separate antenna array, e.g. antennas 140R-142R. Utilizing in/out of band control signals, the SM\_MA configurable receiver 380 of the subscriber unit 138, in the embodiment shown, may be configured for

5 spatial/traditional mode signal reception on the requisite channel within the multiple access protocol. In the case of spatial mode communications, the antenna array, e.g. antennas 140R-142R, detect downlink composite signals derived from the spatially separate transmission of the substreams through antennas 134T-136T. These composite signals are down converted, demodulated and sampled by the receiver first

10 stage 382. The composite signals are then passed to the receive processing module 384 and may be subject to receive side processing if implemented. From the receive processing module, the composite signals are passed to the spatial processor 386. The spatial/space-time processor via in/out band control signals is also configured to derive the appropriate number of substreams, i.e. equivalent to the number

15 transmitted, from the BTS(s). Utilizing logic associated with space/space-time processing (see FIGS. 7A-D), that processor, in conjunction with decoder 388, generates estimated source substreams which are passed to the combiner 390. The combiner 390 via in/out band control signals is also configured to combine the substreams into an estimated subscriber datastream(s) corresponding to that

20 transmitted from the BTS 132. The datastream(s) are passed to the I/O module for presentment/delivery as, e.g., audio, image or data. Where communications are asymmetric, the uplink may, in an embodiment of the invention, not include SM capability, leaving that capability to the downlink alone. This asymmetric capability may be implemented on either the downlink or the uplink without departing from the

25 scope of this invention.

The uplink from the subscriber unit 138 to the BTS 132 may use the same or different hardware/firmware/processes/logic to that utilized for the downlink. In an embodiment of the invention, the uplink is traditional with no SM\_MA capability. In the embodiment shown in FIG. 3A, the uplink includes both SM and MA

30 processes/logic. The datastream(s) received by the I/O module 352 are passed to parser 354. In an embodiment of the invention, the parser is configurable to generate a traditional datastream or a variable number of substreams thereof. In another embodiment of the invention, the parser parses all datastream(s) into a fixed number

of substreams. Where there are no SM uplink capabilities there is no parser. In other embodiments of the invention, the configurable parser also includes a mode detector to determine whether the datastream(s) should be split into substreams. That determination, as discussed above, may be based on any number of criteria including, but not limited to, traditional vs. spatial mode, QoS, bit rate requirement, feasibility, etc. In such an embodiment, when the mode detector determines that spatial mode transmission of the datastream is appropriate, the parser will split the datastream(s) into a plurality of substreams, the number of which may itself be configurable. These substreams are then passed to the selector 356. The selector responsive to in/out of band control signals implements the appropriate access protocol, including the placement of the datastream(s) and/or substreams onto the appropriate channel within that protocol. The datastream(s) and/or substreams thereof are then optionally passed to transmit processes/logic 358, which may implement any number of well-known prior art signal processing techniques, including the above discussed diversity methodology, to improve signal reception. The substreams and/or datastream(s) are then passed to the final transmit stage 360 where they are encoded, modulated, and up-converted for transmission on a single channel through spatially separate transmit antennas 140T-142T. Composite signals corresponding thereto are received by antennas 134R-136R of the SM\_MA configurable receiver 330 of the BTS.

As discussed above, where the uplink is asymmetric, the BTS may not implement or require SM on the uplink. Nevertheless, in the embodiment shown, the receiver 330 is SM\_MA configurable. The receiver 330 includes a first stage receiver 332, mobility detector 334, receive processes/logic 336, spatial/space-time processor 338 and a decoder 340. The composite signals are passed by antennas 134 R-136 R to the first stage receiver. This is configurable to receive the communications on the appropriate channel within the MA protocol as determined by SM\_MA processes/logic 104. These composite signals are down-converted/demodulated and sampled. In an embodiment of the invention, the mobility detector 334 monitors the composite signals for Doppler shift/spread. Doppler shift/spread of the composite signals correlates with the mobility or lack thereof of the subscriber unit. The absence of a Doppler shift/spread indicates that the subscriber unit is fixed. This determination on the part of the mobility detector may be used to initiate one or more of the following processes/logic: spatial reconfiguration, training/retraining of the

spatial/space-time processors and/or handoff. In an embodiment of the invention in which non-blind in band training is implemented, training/retraining may include varying the training interval or duration or selection of a different training sequence. The composite signals are then passed to the optional receiver processes/logic 336.

5 These processes/logic, as described above, may include any of a number of well-known techniques including diversity processing. The composite signals are then passed to the configurable space/space-time processor 338. Utilizing in/out of band control signals from the MSC and/or the subscriber unit, the space/space-time processor configures itself to generate a number of substreams or a single

10 datastream(s) equivalent to those transmitted from the corresponding subscriber unit. These estimated subscriber substreams/datastream(s) are then passed to the decoder 340. The decoder decodes the symbols to their corresponding binary equivalent. The datastream(s) and/or substreams are then passed to upstream processes/logic 300.

Both the subscriber unit 138 and the BTS 132 are shown to include

15 respectively control modules 370 and 320. These control modules implement a subset of the control processes/logic 104 required to implement the SM\_MA processes, such as training of the space/space-time processors 338 and 386, etc.

### Training

Training refers to the requirement that, in order to implement a space/space-time processing on the receive side of whichever link down/up is implementing SM, it

20 is necessary that the space/space-time processor be equipped with an appropriate model of the spatial characteristics of the environment in which the signals will be passed between the subscriber unit and the associated BTS(s). Different types of training methodology may be appropriate, depending on whether the subscriber units

25 are fixed/mobile, and if mobile, depending on the speed at which they are moving. Where a subscriber unit is fixed, training may be accomplished on installation of the unit, at setup of a call or during a call session. Where a subscriber unit is mobile, training/retraining must take place continuously or intermittently. Training for a fixed subscriber unit may take place intermittently as well, although generally at a lower

30 frequency than that associated with a mobile subscriber unit.

Training is generally categorized as blind or non-blind. Training is non-blind when it is incorporated intermittently/continuously using in/out of band training

signals, e.g. known sequences such as Walsh codes, transmitted between subscriber unit and BTS(s). Training is blind when it takes place without such signals, relying instead on non-Gaussianity, CM, FA, cyclostationarity or the spatial structure, such as the array manifold. The performance of blind methods will, of course, be sensitive to the validity of structural properties assumed. An excellent reference on the subject, which is incorporated herein by reference as if fully set forth herein, is found in: “*Space-Time Processing for Wireless Communications*”, Arogyaswami J. Paulraj and Papadias, IEEE Signal Processing Magazine, November 1997, at pages 49-83. In an embodiment of the invention, non-blind training methods are utilized to configure the space/space-time processors. Further details on the space/space-time processor will be provided in the following FIGS. 7A-D and accompanying text.

Control module 320 includes: processor 324, clock 326, training module 328 and memory 322 for the storage of weights/parameters for the space/space-time processor 338. Control module 370 in the subscriber unit 138 includes: processor 374, clock 376, training module 378 and memory 372 for the storage of weights/parameters for the space/space-time processor 386. In the embodiment of the invention shown in FIG. 3, the CPU implements the training portion of the control processes/logic 104. In alternate embodiments of the invention, the CPU may be utilized to implement other of the control processes/logic. In still other embodiments of the invention, the training portion of the control processes/logic is handled upstream at such locations as the MSC or the CO.

In an embodiment of the invention which implements non-blind training, the mobility detector 334 signals the CPU 324 when a subscriber unit exhibits minimal Doppler shift/spread, e.g. is fixed. In an embodiment of the invention, the CPU 324 directs the transmit module 310 to signal subscriber unit 138 at call setup, or at the start of a call session, to use stored parameters from an earlier training session or to process a setup training session transmitted by the BTS. In another embodiment of the invention, the CPU may reduce the frequency or duration of a training sequence responsive to a determination that the Doppler shift/spread is minimal.

On the BTS side, the training module 328 inserts a known training sequence, e.g. Walsh code, into the downlink transmissions and these are processed by the CPU 374 of the subscriber unit and weights derived therefrom which allow the



space/space-time processor 386 to separate the training sequence spatially broadcast from the antenna array of the BTS(s). Similarly, where the uplink implements SM, the subscriber unit training module 378 inserts a known training sequence into the uplink transmissions as well. These are in turn processed by the CPU 324 and  
5 appropriate weights derived therefrom stored in the spatial processor 338 for use with the uplink communications during the call/data-transfer session. Whenever training/re-training takes place, weights are recalculated and stored for use in subsequent SM communications.

Where the mobility detector 334 determines that the subscriber unit is mobile,  
10 an alternate non-blind training methodology may be implemented. In an embodiment of the invention, that methodology shown in FIG. 8 involves inserting into in/out of band downlink communications the known training sequence. This allows updating of the spatial parameters/weights by the corresponding subscriber unit and its space/space-time processor. This capability allows spatial multiplexing to be  
15 implemented in both a mobile and a fixed environment. In still another embodiment of the invention, the duration/frequency at which the training intervals are inserted into the up/down link communications may be varied depending on the mobility of the subscriber unit.

In still another embodiment of the invention, blind training methods may be  
20 implemented. These unsupervised methods do not need training signals because they exploit the inherent structure of the communication signals.

As will be obvious to those skilled in the art, the processes/logic 104 and the associated modules/blocks discussed above and in the following disclosure may be implemented in hardware, software, firmware or combinations thereof without  
25 departing from the teachings of this invention. They may be implemented on a single chip, such as a digital signal processor (DSP), or application specific integrated circuits (ASIC). On the upstream side (i.e., BTS, MSC, CO, etc.), the SM\_MA processes/logic 104 may physically reside in any one or all upstream units. The processes/logic may be implemented using master-slave control relationship between  
30 CO/MSC and BTS or peer-to-peer control relationship between BTSs alone, or distributed control between CO/MSC and BTS.

FIG. 3B illustrates a detailed hardware block diagram of a subscriber unit 138 and a BTS 132 similar to the system described in FIG. 3A. The difference in this embodiment is that the subscriber unit is connected to a network 240 and thus the I/O modules 352 and 392 in the transmitter 350 and receiver 380 respectively are coupled to the network 240. Of course, the subscriber unit could readily communicate with any type of network or network device.

FIGS. 4A-F show an embodiment of the BTS/MS/CO side of the processes/logic 104\_ for implementing SM\_MA. FIGS. 4A-B and 4D-E show a partial handoff.

FIG. 4A shows BTSs 120 and 132 coupled to MSC 106 and to the associated upstream processes/logic 300 of processes/logic 104\_. The BTS 120 is shown with the associated final transmission stage 316B and the selector 312B. The BTS 132 is shown coupled to the final transmission stage 316A and to the selector 312A. The upstream processes/logic 300 include a detector 400, parser unit 402 and router 420. The parser unit 402 includes a parser module 404 and clock 406 as well as a stretcher 408 and its clock 410. The MSC 106 is shown coupled via its data/control line 108 to each of the above-discussed modules.

As will be obvious to those skilled in the art, the coupling between the MSC and each of the above-discussed hardware and software modules represents a master/slave embodiment of the current invention. In alternate embodiments of the invention, peer-to-peer control methodology may be utilized instead. In still another embodiment of the invention, distributed control methodology may be implemented, e.g. each of the above-discussed modules may contain additional intelligence, sufficient to signal downstream/upstream modules as to the appropriate configuration to adopt, responsive to the datastream(s)/substreams being processed, the channel and access methodology to be utilized.

Datastream(s) 176 is delivered to mode detector 400. In this embodiment of the invention, a mode detection is utilized. As discussed above, this module provides the capability of distinguishing datastream(s). Datastream(s) might, as discussed, be categorized as traditional vs. spatial, or on the basis of QoS or bit rate requirement. In the embodiment shown, the detector 400 determines that the datastream(s) 176 is destined for spatial mode processing. Responsive to that determination, the parser

404 is configured to parse the datastream(s) 176 into a plurality of the substreams. In the example shown, the two substreams 450-452 are generated by the parser. The substreams each contain a portion of the actual data from the original datastream(s). The function of the stretcher 408, to which the substreams are passed, is to effectively lower the baud rate at which the substreams are transmitted. Figuratively, this is accomplished by clocks 406 and 410 which are coupled to respectively the parser and the stretcher. Clock 410 operates at a rate which is a fraction of the rate of clock 406. The specific fraction is determined by the number of substreams generated by the parser 404. For example, if parser 404 generates from a single datastream(s) two substreams, then each of the substreams will be transmitted at a baud rate which is effectively 1/2 that of the original datastream(s). The stretched substreams are then passed to the router 420. In an alternate embodiment of the invention, the substreams need not be stretched, rather buffered and transmitted at the same baud rate in bursts, if the channel will support the resultant communication rate. The router operating, in the embodiment shown, under the control of the MSC 106 sends the selected substreams 454 and 456 to a single BTS 132 for single-base spatial transmission from each of the spatially separate antenna of that BTS. Those substreams passed through the selector 312 are injected on an appropriate channel within the multiple access protocol. The channel determination is made by the SM\_MA processes/logic 104 that portion of which may be localized in a master/slave control implementation at the MSC. The substreams are then passed to the final transmission stage 316A for transmission to the subscriber unit 150 (see FIG. 6).

FIG. 4B shows hardware/software modules identical to those discussed above in connection with FIG. 4A. The router 420, responsive to a signal from, for example, the MSC 106 has re-routed one of the substreams to BTS 120. That substream 454 is passed to the selector 312B associated with BTS 120. The corresponding substream 456 is presented to selector 312A associated with BTS 132. Under the control of the MSC, each selector is directed to place the substreams on the same MA channel on each of the base stations. The final transmission stages 316A-B of each BTS places the substreams on one antenna of its spatially separate antenna array for transmission to the subscriber 150. The subscriber 150 is in a location in which the signals from base stations 120 and 132 overlap. The composite signals 180 and 178\_M resulting from the transmission of spatially distinct subscriber substreams are received with

spatially separable signatures by the subscriber unit 150 which, as discussed above, is equipped with spatially separate antennas.

The determination to move from a single-base spatial transmission (see FIG. 4A) to multi-base spatial transmission, as shown in FIG. 4B, may be made as a result of any one of the number of distinct determination methods. In the first of these methods, an evaluator portion of either the space/space-time processor 386 or the decoder 388 of the subscriber unit 138 determines that an incoming composite signal cannot be spatially separated into the required number of substreams. In response to this determination, the subscriber unit signals the BTS that a change of spatial configuration is required. This signal is processed by the BTS and may be passed to the MSC 106. In response, the MSC directs the router and selected BTSs, e.g. BTSs 120 and 132, to prepare for and transmit the substreams on an assigned channel. This transition from single-base to multi-base spatial transmission is handled transparently to the subscriber, in order to maintain a consistent QoS throughout the transmission by increasing the spatial separation of the transmitted substreams.

FIG. 4C shows an alternate embodiment of the invention that includes the capability of mode detecting between, for example, traditional and spatial mode datastreams. Datastream(s) 182 is presented to detector 400 via data/control line 108. The datastream(s) might, for example, be a traditional subscriber telephone call or a datastream which has both a low bit rate and QoS requirement. To minimize resources, it may be advantageous for the parser unit 402 to be configurable, so as not to subject all incoming datastream(s) to parsing or, if parsed, so as not to parse into a fixed number of substreams. In the embodiment shown, such capability is implemented. The detector determines that the datastream is traditional mode. That determination may result in the parser avoiding the parsing of the datastream 182. The datastream(s) 182 is passed unparsed to the router 420. The router 420 passes the datastream(s) 182 to the selector 312A of the associated BTS 132. Under the control of the MSC the selector and the final transmissions stage 316A inject the datastream(s) 182 on the appropriate channel of the appropriate multiple access protocol and transmit it via a selected one of the antennas, within the array from which it is received, by subscriber unit 144. That subscriber unit may be a traditional mobile phone lacking any spatial transmission characteristics. Alternately, the subscriber unit may be spatially configurable as well (see FIG. 2A). In this latter

case, BTS 132 injects a control signal to the spatially configurable subscriber unit 144 and, in particular, to the configurable space/space-time processor thereof, indicating that the incoming composite signals are to be treated as a single datastream(s). As will be obvious to those skilled in the art, traditional mode datastreams including, for example, traditional voice telephone calls, may be subject to SM.

As will be obvious to those skilled in the art, each of the above-discussed datastream(s) 178, 176, 182 may include multiple subscriber sessions, time-division multiplexed for example. In this case, all the above-mentioned methodology may be practiced successively on each of the subscriber sessions of a single datastream.

FIG. 4D shows multiple subscriber datastream(s) presented to the detector 400. Specifically datastream(s) 176 and 182 are shown. The first of these datastream(s) is destined for spatial treatment and the second of these datastream(s) 182 is destined for non-spatial treatment. This determination is made by the mode detector 400 based on criteria including, but not limited to, those discussed above. The parsing unit 402 is, in this embodiment of the invention, configurable to concurrently handle multiple subscriber sessions. Upon receipt of control information received either directly from the detector 400 or indirectly from the MSC 106, the parsing module 402 performs the following concurrent operations. The traditional mode datastream(s) 182 is left unparsed and passed directly to the router 420. The spatial mode datastream(s) 176 is parsed by parser 404 into substreams 450-452. These substreams are stretched in stretcher 408, as discussed above, and passed to router 420. The router 420, operating under the control of the MSC, for example, directs each of the datastream(s) and substreams to a single BTS 132 and specifically the associated selector 312A of that BTS.

These substreams generated by the parser are labeled 450-452. The substreams passed by the router are labeled 454-456. This change in reference number is meant to indicate that the initial parsing operation may be accompanied by a lowering of the bit rate or stretching of the clock on which these substreams are transmitted. As will be obvious to those skilled in the art, an alternate methodology for implementing the invention would be to maintain the same the bit rate, provided it was compatible with the bandwidth of the wireless channel on which the transmission

was to take place, and to buffer the data accordingly for transmission in bursts, along with other similarly processed datastream(s)/substreams.

Under the direction of the MSC, for example, the selector 312A and final transmission stage 316A of BTS 132 transmit the substreams 454-456 on a common channel and, depending on the access methodology, may transmit the datastream(s) 182 on the same or another channel. Signal 182 is transmitted from an antenna of BTS 132 to subscriber unit 144. The individual substreams and the associated signals 180, 178\_S of the spatial mode datastream(s) 176 are transmitted to the subscriber unit 150.

FIG. 4E shows an embodiment of the invention identical to that described and discussed above in connection with FIG. 4D. Router 420 re-routes one of the substreams 454-456 of the spatially processed datastream(s) 176 to form a multi-base spatial transmission configuration. That determination to re-route, as discussed above, may originate either from signals received from the corresponding one of the subscriber units which is unable to spatially separate the substreams or alternately may result from a determination by the BTS initially implementing single-base transmission that the bit error rate (BER) is unacceptably high. In this example, subscriber unit 144 continues to receive composite datastream(s) 182 from an antenna on BTS 132. The composite signals received by subscriber 150 now, however, originate from a multi-base configuration. The substream 454 has been re-routed by router 420 to BTS 120, so the composite signals 180, 178\_M originate from BTSs 132,120, respectively.

As will be obvious to those skilled in the art of the reference, in single or a multi-base spatial transmission, discussion to a substream been transmitted from a single antenna, should not be interpreted as a limitation on the teachings of this invention. A single substream in single or multi-base configuration may be transmitted from more than one antenna, if diversity or beam forming transmit processes are implemented in addition to spatial multiplexing.

FIGS. 4F-J show an alternate embodiment of the invention in which the router, as described and discussed above in connection with FIGS. 4A-E, is positioned upstream of the parsing unit rather than downstream of that unit. Consequently, each

of the base stations has associated with it a corresponding parsing unit. FIGS. 4F-G and FIGS. 4I-J show a partial handoff.

FIG. 4F shows MSC 106, BTSs 120 and 132 and the upstream processes/logic 300. Each of the base stations 120 and 132 includes selectors and final transmission stages. Within the upstream processes/logic 300, the detector 400 communicates directly to the router 422. The router, in turn, communicates directly with the parsing units 402A-B associated with BTSs 132 and 120, respectively. Single-base spatial processing of subscriber datastream(s) 176 is shown. The subscriber datastream(s) 176 is received by the detector 400. The detector determines that the mode of the datastream(s) is spatial and that information is passed to the router 422. The router routes the datastream(s) 176 to the appropriate parsing unit 402A. The parsing module 404A of that unit parses the datastream(s) into substreams, e.g. substreams 450-452. Those substreams are passed to stretcher 408A which is coupled to selector 312A. The selector places both the stretched substreams 454-456 on the appropriate channel of the selected MA protocol. Those substreams are transmitted by the final transmit stage 316A of the BTS 132. The signals 178\_S and 180 are transmitted to subscriber unit 150, along with the control information necessary for that subscriber unit to properly process the incoming communication.

FIG. 4G shows a multi-base implementation of the configuration described and discussed above in connection with FIG. 4F. The detector 400 determines that the datastream(s) 454-456 require spatial processing. Additionally, multi-base transmission is determined to be necessary based, for example, on a subscriber unit signal or on the BER detected by a BTS. The router 422, responsive to that determination, routes the datastream to parsing units 402A-B. Each of the parsing modules 404A-B is presented information, not only that the datastream(s) needs to be parsed, but also which substreams are to be discarded at each parsing unit in order to implement a multi-base spatial transmission. In an embodiment of the invention, those in control instructions are generated by the MSC 106. The parsing module 404A generates substream 452. The parsing module 404B generates substream 450. Collectively, substreams 450-452 contain all the information from the original datastream(s) 176 from which they were parsed. The selected substreams are passed to the corresponding stretching modules 408A-B. These stretching modules in turn pass the substreams with a reduced bit rate or in bursts as substreams 456-454 to the

corresponding selectors 312A-B of the associated BTSs 132 and 120. The substreams are placed on the same channels of the multiple access protocol implemented by each BTS. These substreams are transmitted by the corresponding final transmissions stages 316A-B. Signal 180 corresponding to substream 456 is transmitted by at least  
5 an antenna on BTS 132 to subscriber unit 150. Signal 178\_M corresponding to substream 454 is transmitted by at least an antenna of BTS 120 to subscriber unit 150. The inclusion of both single-base and multi-base spatial transmission capabilities in the system allows consistent QoS to be delivered to the subscribers.

FIG. 4H shows an implementation of the current invention in which the  
10 detector 400 includes the capability of distinguishing the mode of the datastream(s), e.g. traditional mode and spatial mode. The detector 400, upon determining that datastream(s) 182 can be processed in traditional mode, passes that information to the router 422. The router passes the datastream(s) 182 to the appropriate parsing unit 402. The parser unit 402A and specifically parser module 404A thereof avoids  
15 parsing the datastream(s) and passes it to the corresponding selector 312A associated with BTS 132. In the manner described and discussed above, the channel and antenna on which that datastream(s) is to be transmitted from BTS 132 is determined by the processes/logic 104, e.g. at the MSC. The associated signal 182 is passed from the BTS to the subscriber unit 144.

FIG. 4I shows the introduction of multiple subscriber datastream(s), i.e. datastream(s) 176 and 182 into the embodiment described and discussed above in connection with FIGS. 4F-H. The detector 400 determines that datastream(s) 182 may be processed in the traditional mode while datastream(s) 176 may be processed in the spatial mode. In this example, both the datastream(s) are routed by router 422  
25 to a single BTS for, respectively, non-spatial and spatial transmission. Stretched datastream(s) 454-456 derived from substreams 450-452 of datastream(s) 176 are presented to the selector associated with BTS 132. Signals 178\_S and 180 are transmitted to subscriber unit 150 on the same channel of the MA protocol implemented by the BTS. Traditional mode datastream(s) may be transmitted on the  
30 same or another channel.

FIG. 4J shows a multi-base spatial transmission of the datastream(s) 176 discussed above in connection with FIG. 4I. A change from single to multi-base



transmission is initiated by the processes/logic 104\_ in response to, for example, a degradation in the bit error rate or to signals from subscriber unit 150 which indicate that a change in spatial configuration is required. This might include changing the antenna selection on the array of a single BTS. The selection might involve a  
5 reduction/increase in the number of transmitting antennas. Alternately, in the example shown, a partial handoff is implemented. To implement the partial handoff, router 422 routes the datastream(s) 176 to both parsing units 402A-B. Control information, indicating which of the substreams generated by the respective parsing unit is to be passed on to the associated BTS, may also be generated. Responsive to  
10 that information, the parsing modules 404A-B each generate only one of the substreams which can be generated from the datastream(s) 176. Each selected substream is stretched by the corresponding stretcher and passed to the corresponding BTS. BTS 132 continues to transmit the traditional mode datastream(s) 182 and the signal corresponding thereto to subscriber unit 144. BTS 132 transmits one of the  
15 stretched substreams 456 in the form of signal 180 to subscriber unit 150. The other of the substreams 454 is passed to the subscriber unit 150 as signal 178\_M from the BTS 120.

As will be obvious to those skilled in the art, the above-mentioned arrangements of detector, router and parsing units represent only some of the possible  
20 configurations of these modules/logic which may be utilized to implement the current invention. In an embodiment of the invention, the wireless network may not support both traditional and spatial transmission together. In that embodiment, the detector may not be required, since all datastream(s) will be handled by spatially transmitting them. In still another embodiment of the invention, multi-base operation may not be  
25 implemented, allowing only for single-base SM. In still another embodiment of the invention, the routing may be accomplished by a single BTS which uses in/out of band channels to wirelessly relay one or more substreams to other BTSs for re-transmissions on the assigned channel.

FIGS. 5A-B show the upstream modules associated with the processing of  
30 datastream(s) and substreams received by the BTSs. That information may be destined for another subscriber unit or for the network 100 (see FIG. 1A).

FIG. 5A shows the base stations 120,132, the upstream processes/logic 300 and the MSC 106. In the example shown, single-base SM is implemented. The subscriber unit 150 is shown transmitting signals 178\_S and 180. These are received by BTS 132 and processed by the associated modules of its configurable SM receiver 330 (see FIG. 3). From the decoder 340A, substreams 454-456 are passed to the upstream processes/logic 300. The upstream module includes a router 420 and a combiner 500. The combiner 500 operates in reverse of the manner described and discussed above in connection with the parsing unit 402. The router 420 passes the substreams 454-456 to the combiner 500. The output of the combiner is the subscriber datastream(s) 176.

FIG. 5B shows the modules discussed above in connection with FIG. 5A during the reception of multi-base spatial transmissions from the subscriber unit 150 as well as the single-base transmission from subscriber unit 144. BTS 132 and the associated receiver module 330, have their spatial processor configured to generate a single one of the substreams 456 that can be derived from the composite signals 178\_M and 180 of subscriber unit 150. The other substream 454 is generated by corresponding modules associated with BTS 120. Additionally, on the same/different channel, BTS 132 with the receiver 330 is configured to generate a single datastream(s) 182 from the composite signal 182 transmitted by the subscriber unit 144. The datastream(s) 182 of the associated decoder of that BTS, i.e. decoder 340A is passed to the router 420. The combiner is configured to combine substreams 454-456 into datastream 176 and to pass datastream(s) 182 along without combining.

Thus, in an embodiment of the invention, the method and apparatus of the current invention may be used to implement SM\_MA both on the down/up link. As will be obvious to those skilled in the art, SM may be asymmetrically implemented as well, on either the down/up link selectively, without departing from the scope of this invention.

FIG. 6 shows an antenna array of BTS transmitter 132 and the antenna array of the subscriber unit receiver 138 (see FIG. 3). The antenna array of the final transmissions stage 316 includes antennas 134T-136T. The antenna array of the first receiver stage 382 includes antennas 140R-142R. The first receiver stage passes the composite signals 640-642 to the space/space-time processor 386. The output of the

processor is presented to the decoder 388 from which, as output, the substreams 454-456 are generated.

As will be obvious to those skilled in the art, the transmission of data through a wireless medium may involve modulation of an information signal derived from a datastream(s) or substream on a carrier signal. Information may, for example, be contained in the phase and/or amplitude relationship of the signal modulating the carrier. Each specific phase and/or amplitude relationship that is utilized is referred to as a "symbol". The set of all symbols is referred to as the "constellation". The greater the number of symbols in a constellation, the more binary bits of information may be encoded in each symbol in a given constellation. Current communication protocols allow for constellations with over 1024 symbols, each encoding for one of ten bit combinations. Antenna 134T is shown transmitting a symbol 600 within a signal constellation. This corresponds to an associated group of the bits corresponding to the data from a portion of substream 454. Antenna 136T is shown transmitting symbol 606 which corresponds to a different bit sequence derived directly from substream 456. The transmission of substream 454 by antenna 134 results in at least two signals 602-604. The transmission of the symbol 606 by antenna 136 generates at least two signals 608-610. Additional signals are likely in a multi-path environment with numerous scattering objects, such as buildings, etc. For the sake of simplicity, signals 602 and 610 transmitted from respectively antennas 134T-136T are both received by antenna 140R as a single composite signal. The corresponding signals 604 and 608 are received by antenna 142R as a single composite signal. In order for the spatial receiver of the subscriber unit to resolve the composite signals into the estimated subscriber datastream/substreams, the spatial processor 386 must include information about the spatial signatures 620-622 of the transmissions from each of the antennas 134-136. These spatial signatures may be determined using either blind and or non-blind training methods in the manner described and discussed above. By placing the decoder 388 downstream from the space/space-time processor 386, the appropriate symbols may then be derived from the substream and converted into a corresponding binary sequence from which the corresponding portions of the substreams 454-456 may be generated.

As will be obvious to those skilled in the art, any of a number of other modulation techniques may be used to implement the current invention including:

continuous phase modulation (CPM), continuous frequency modulation (CFM), phase shift keying (PSK), offset phase shift keying, amplitude shift keying (ASK), pulse position modulation (PPM), pulse width modulation (PWM), etc., without departing from the scope of this invention.

5           FIGS. 7A-B show an embodiment of the invention in which the spatial processor 386 is configured for both traditional and spatial mode signal reception. Additionally, in the spatial mode, the spatial processor is configurable to generate a variable number of substreams to correspond to the number transmitted. Spatial processor 386 and the decoder 388 are shown. The spatial processor 386 includes:  
10 first fabric switch 700, first configurable logic 702, second fabric switch 730, second configurable logic 732, an evaluator 740, and a controller 746.

The spatial processor 386 is coupled via the receive processes 384 to the receiver first stage 380 of the subscriber unit, as discussed above in connection with FIG. 3. Similar design applies to the spatial processor 338 in the BTS (see FIG. 3).  
15 The composite signal(s) detected by the first stage receiver is passed to the fabric switch 700 of the spatial processor. Responsive to signals generated by the control unit 746, the first fabric switch passes the composite signal/signals to one or more of the sub-modules within first logic unit 702. In the embodiment shown, a sub-module includes a multiplier 704 and a weight register 712. The multiplier generates an  
20 output signal which is a product of the weight stored in weight register 712 multiplied by the incoming composite signal. The weights in this register and the register of other sub-modules may be derived using non-blind or blind training methods as discussed above. In the example shown in FIG. 7A, a composite signal 750 is presented to fabric switch 700. This switch has been configured utilizing in/out of  
25 band control signals to process a single composite signal. The output of the multiplier is presented to the second fabric switch 730. This fabric switch also is configurable by means of the control unit 746. The fabric switch 730 presents the signals from the first logic module in variable configurations to one or more of the summers, e.g. summer 734 which is part of the second configurable logic in this embodiment of the  
30 invention. Because a single composite signal is being processed in the embodiment shown in FIG. 7A, only one summer is utilized. The input to that summer is the output of the multiplier 704 and the zero input provided by the control unit 746. The output of the summer 734 is passed to the evaluator 740 (optional). The evaluator

determines when signals that are spatially transmitted are not separable, and if separable, the quality of each link. The quality of each link may be evaluated using, for example, Signal to Interference Noise Ratio (SINR). The resultant traditional mode datastream(s) 182 is passed through the decoder. In the decoder the conversion  
5 from symbols to associated bit sequences is implemented. As shown above in FIG. 3, the output of the decoder is passed to an associated combiner. The configuration of the configurable spatial processor under the control of control unit 746 takes place as a result of in/out of band control signals. These signals may be generated during call setup or during an actual call session by SM\_MA processes/logic 104.

10 In FIG. 7B, the configurable nature of the spatial processor is evident by comparison to FIG. 7A. Composite signals 640-642 are presented to the first fabric switch 700. Responsive to signals from the control unit 746, the first fabric switch generates output signals for each of the composite input signals. Composite signal 640 is passed to a first pair of logic sub-modules within the first logic unit 702.  
15 Composite signal 642 is passed to a second pair of logic sub-modules within the first logic unit 702. The first pair of logic sub-modules include: multiplier 704 together with associated weight register 712, and multiplier 706 together with associated weight register 714. The second pair of logic sub-modules include: multiplier 708 together with associated weight register 716, and multiplier 710 together with  
20 associated weight register 718. Multipliers 704-706 receive as inputs the composite signal 640. Multipliers 708-710 receive as inputs the composite signal 642. The weight registers may contain weights obtained during transmission of a training sequence which allow training sequences to be separated. These are multiplied by the corresponding composite signal inputs and the four products are cross-coupled to  
25 summers 734-736 of the second logic unit 732 by the second fabric switch. The output of summers 734-736 is, respectively, the estimated substreams 454-456. In the embodiment shown, these are passed through an evaluator 740 to the decoder 388. Subsequently, the estimated substreams are combined into the original datastream 176 (not shown). The decoder 388 performs the above-mentioned function of mapping  
30 the summer output into symbols and from the symbols, into the appropriate binary sequences. In an alternate embodiment of the invention, the evaluator may be placed downstream of the decoder and perform a similar function at that location.

The evaluator monitors the estimated substreams to determine if they are appropriately separated, and if separable, the quality of the link(s). This determination might, for example, be made during the transmission of a training sequence. When the evaluator determines it is no longer possible to spatially separate the corresponding substreams, that determination may be passed to the upstream processes/logic 104, e.g. the MSC 106 (see FIG. 1). This results in an alteration of the spatial configuration of the transmission. A change in spatial transmission may be implemented in any number of ways. These include: a change in the antenna selection and/or number at a single base, a change from traditional to spatial mode broadcasting at a single base, a change from single-base to multi-base transmission. Similarly, when the evaluator determines that the substreams are separable, it may pass on the link quality parameters to the upstream processes/logic 104, e.g. the MSC 106. This can help the BTS/MS/CO side of the processes/logic 104\_ choose the modulation rate (bits per symbol) of each substream, and carry out parsing accordingly.

FIGS. 7C-D show an embodiment of space-time processor. To the capabilities of the above-discussed spatial processor is added the ability to remove the interference in the composite signal caused by the delayed versions of the composite signal over time. To account for these perturbations, one or more delay elements may be introduced into the signal paths in the first logic unit to account for these effects. An exploded view of an embodiment of a time logic sub-module is shown in FIG. 7D. In the embodiment shown, each time sub-module is coupled to the output of a corresponding multiplier in the first logic unit. Time sub-modules 720-726 are coupled to the outputs of multipliers 704-710, respectively. Each time module may consist of a plurality of delay elements. In the exploded view, a sub-module includes delay modules 760-762; multipliers 770-772 together with associated weight registers 780-782, as well as a summer 790. The output of multiplier 704 is an input both to delay module 760 and summer 790. The output of delay module 760 is an input both to delay module 762 and to multiplier 770. The output of delay module 762 is an input to multiplier 772. The outputs of the multipliers provide additional inputs to the summer 790. The output of the summer is presented to the second fabric switch 730. Each time module may include additional multipliers with associative delay units and weight registers. As was the case in FIGS. 7A-B, the space-time processor in FIGS. 7C-D is configurable. FIG. 7C shows the processor configured for a single input

composite signal 750. FIG. 7D shows the space-time processor configured for two composite input signals 640-642.

The spatial/space-time processor of FIGS. 7A-D is configurable; e.g. capable of processing a variable number of composite signals and outputting a corresponding number of estimated subscriber substreams. In another embodiment of the invention, the spatial/space-time processor is not configurable; accepting instead a fixed number of substreams and outputting a corresponding fixed number of estimated subscriber substreams.

As will be obvious to those skilled in the art, any of a number of other processing techniques may be used to implement the current invention, including: space-time, space- frequency, space- code. etc. In turn, these may further utilize any, or a combination of techniques including, but not limited to: linear or non-linear processing, Maximum Likelihood (ML) techniques, Iterative decoding/interference canceling, Multi-user detection (MUD) techniques, etc., without departing from the scope of this invention.

FIG. 8 shows a datastream interspersed with the training sequences consistent with a non-blind embodiment of the current invention. Training sequences 800-802 and data sequences 850-852 are shown. Suitable training sequences include orthogonal Walsh codes transmitted by the spatially separate antennas. The spatial/space-time processor of the receiver attempts to generate weights which separate the known Walsh code sequences. Those weights are then used in processing the subsequent datastream(s)/substreams. In an embodiment of the invention, the training sequences are inserted into the datastream at frequency/duty cycle, which depend on the mobility of the subscriber unit. In another embodiment of the invention, the training sequences vary in duration and are constant in frequency. The training sequences may be transmitted in/out of band. As the mobility of a subscriber increases, the frequency/duty cycle of the training sequences may be increased. The mobility of the subscriber unit can, as discussed above, be detected by Doppler shift/spread detected by the mobility detector 334 (see FIG. 3) on the receive side of the base station, for example. When the subscriber unit is fixed, training may only be performed at, or before, call setup or at a relatively low frequency/duty cycle during a call/data session. In still other embodiments of the invention, no training sequences

would be inserted into the datastream(s)/substreams, instead relying on blind training techniques discussed above.

FIGS. 9A-B to 12A-B show various access methodologies utilized to provide multiple-access spatial multiplexing in accordance with the current invention. The figures labeled with "A" show the transmit portion of each access method while the figures labeled with "B" show the receive side. FIGS. 9A-B show SM time-division multiple access (TDMA). FIGS. 10A-B show SM frequency-division multiple access (FDMA). FIGS. 11A-B show SM code-division multiple access (CDMA). FIGS. 12 A-B show SM space-division multiple access (SDMA). The modules disclosed herein on the upstream side, as well as the subscriber side, may be implemented in hardware/software. They may be implemented on a single chip, e.g. DSP or ASIC. The modules disclosed on the upstream side may be located in the BTS or further upstream, e.g. the MSC/CO. On the subscriber side the modules may be implemented in a single unit.

FIG. 9A shows a slot selector 900, a transmit processor module 314A (optional), and a final transmit stage 316A. In the embodiment shown, these are part of the above-discussed BTS 132 (see FIG. 1A). Each of these modules is coupled to the control elements shown in FIG. 3, i.e. training module 328, mobility detector 334, memory 322, processor 324, and clock 326. These are coupled via signal/control line 108 to the MSC 106. The mobility detector is, in an embodiment of the invention shown in FIG. 3, part of the receive side of the BTS. It is shown in FIG. 9A for purposes of clarity, since it interacts with the training module 328 and CPU 324 to detect and generate training sequences responsive to the mobility of the subscriber unit. Subscriber datastream 182 and substreams 454-456 derived from subscriber datastream 176 (see FIGS. 4A-J) are shown as inputs to the slot selector 900. In TDMA each subscriber session is allocated a specific time segment in which to be transmitted. Time segments are assigned in round-robin fashion. In the traditional public switched telephone network (PSTN), there are twenty-four time slots (a.k.a. channels/D0). The slot selector 900, under the direct/indirect control of processes/logic 104 and implemented at, e.g. the MSC 106, assigns the related substreams 454-456 to identical channels (TDMA slots) within the separate TDMA datastream(s) 902-904, which are output by the slot selector. The traditional mode datastream 182 is assigned to a separate channel/slot within TDMA datastream 904.



Each of the TDMA datastream(s) 902-904 is, in an embodiment of the invention, provided as an input to an optional transmit processing module 314A. That module may implement any one of a number of well known prior art techniques for improving signal quality in a wireless network including: diversity, space coding, space-time coding, space-frequency coding, beam forming, interference canceling, etc.

The transmit processor 314A (optional) includes, in the embodiment shown, diversity processing, space-time coding and beam-forming. Beam-forming exploits channel knowledge to direct transmissions to the location of the corresponding subscriber. Diversity may be implemented in: frequency, time, space, polarization, space/space-time, etc. The outputs of the optional transmit processor 314A are provided as inputs to the final transmit stage 316A. That stage includes encoder modulators 924-926, operating off a common carrier 914 for processing each of the TDMA datastream(s) 902-904. These modulated datastream(s) are passed to respective RF stages 934-936 and associated antennas 134T-136T for spatially separate transmission of the individual substreams that they contain, e.g. 454-456. Additional antenna arrays 940-942, RF stages 930-932, encoder/modulator stages 920-922 are used to implement any of the optional transmit processes.

FIG. 9B shows the receive side of a subscriber unit 150 enabled for spatial multiplexing utilizing TDMA access. That unit includes: first receiver stage 382A, receive processor 384A (optional), spatial/space-time processor 386, decoder 388, combiner 390, I/O module 392, TDMA slot selector 978, processor 374, carrier recovery module 376, memory 372, and training module 378. The first receiver stage includes antennas 140R-142R which are coupled via, respectively, RF stages 952-950 to demodulator/sampling modules 962-960. The demodulator/sampling units operate off a common carrier 970. An additional antenna array 946, RF stage 954, demodulator/sampling module 964, and carrier generator 972 are utilized by the receive processor 384A to implement: diversity processing, space-time decoding, beam-forming, etc.

In operation, the carrier recovery module 376 synchronizes the carriers 970-972 to the carrier frequency of the incoming composite signals 990-992. The TDM slot selector 978 accepts a channel assignment from the BTS(s) and synchronizes the

receive processes accordingly. The composite signals from each antenna are demodulated and sampled by the corresponding one of the demodulator/sampling modules 964-960. The outputs of these modules provide inputs to the receive processor 384A. The receive processor implements signal processing techniques  
5 which may complement one or more of the optional processes discussed above for the transmit side (see FIG. 9A). Each composite signal output by the receive processes/logic 384A provides inputs to the spatial/space-time processor 386 (see FIGS. 7A-D). That processor, using parameters/weights derived from the above-discussed blind/non-blind training techniques, separates the composite signals into the  
10 appropriate number of estimated subscriber substreams, e.g. 996-998. In configurable embodiments of the spatial/space-time processor, information received from the BTS(s) at the start of, or during, a call session configures the processor to generate a number of substreams that correspond to the actual number of substreams transmitted. Next, the estimated subscriber substreams are provided as inputs to a similarly  
15 configured decoder 388. The decoder maps symbols utilized during the transmission of the substreams/datastream(s) into their binary equivalent. The decoder outputs the estimated subscriber substreams 454-456 to the combiner 390. The combiner reverses the operation performed on the transmit side by the parser, generating thereby an estimated subscriber datastream 176. This datastream is provided to the I/O module  
20 392 for subsequent presentation to the subscriber as for example, an audio signal, a video signal, a data file, etc.

FIGS. 10A-B show a BTS implementing SM frequency-division multiple access (FDMA). In FDMA, each subscriber session, whether traditional or spatially processed, is provided with a single frequency slot within the total bandwidth  
25 available for transmission. The BTS includes: a frequency slot selector 1000, a transmit processor module 314B (optional), and a final transmit stage 316B. In the embodiment shown, these are part of the above-discussed BTS 132 (see FIG. 1A). Each of these modules is coupled to the control elements shown in FIG. 3, i.e. training module 328, mobility detector 334, memory 322, processor 324, and clock 326.  
30 These are coupled via signal/control line 108 to the MSC 106. Subscriber datastream 182 and substreams 454-456 derived from subscriber datastream 176 (see FIGS. 4A-J) are shown as inputs to the frequency slot selector 900. The selector 1000, under the direct or indirect control of the MSC 106, selects the appropriate frequency slot for

the datastream(s)/substreams. This is represented in FIG. 10A by a final transmit stage which includes encoder/modulator clusters (1020-1022), (1024-1026), and (1028-1030), each of which modulates about a unique center frequency as determined by respective associated carriers 1010-1014. Intermediate the frequency selector 1000 and the final transmit stage 316B, is an optional transmit processing unit 314B which may impose on the datastream(s)/substreams additional signal processing utilizing antenna arrays 1040-1042 in conjunction with antennas 134T-136T, as discussed above in connection with FIG. 9A.

Within the final transmit stage two spatially separate antennas 134T-136T are shown. These are coupled via, respectively, RF stages 1034-1036 and summers (1002-1004),(1006-1008), to separate outputs of each of three encoder/modulator clusters. Each encoder/modulator cluster operates about a distinct center frequency. Each cluster contains a number of encoder/modulator outputs at least equivalent to the number of spatially separate antennas in the final transmit stage. Since there are two antennas in the example shown, each cluster contains at least encoding/modulating capability for processing two distinct substreams and for outputting each separately onto a corresponding one of the antennas for spatially separate transmission. The traditional mode datastream 182 is assigned to the first cluster with a center frequency determined by carrier 1010. That datastream is output via summer 1006 on antenna 136T. Each of the substreams 454-456, parsed from a common datastream 176 (see FIGS. 4A-J) is passed to a single cluster for spatially separate transmission on a single center frequency corresponding, in the example shown, to the center frequency determined by carrier 1012. The modules disclosed herein may be implemented in the BTS or further upstream, e.g. the mobile switching center. They may be implemented as hardware or software. They may be implemented on a single chip, e.g. DSP or ASIC.

FIG. 10B shows a subscriber unit 150 enabled for spatial multiplexing utilizing FDMA access methodology. That unit includes: first receiver stage 382B, receive processor 384B (optional), spatial/space-time processor 386, decoder 388, combiner 390, I/O module 392, frequency selector 1078, processor 374, carrier recovery module 376, memory 372, and training module 378. The first receiver stage includes antennas 140R-142R, which are coupled via RF stages 1052-1050, respectively, to demodulator/sampling modules 1062-1060. The

demodulator/sampling units operate off a common frequency synthesizer 1070. Additional antenna array 1046, RF unit 1054, demodulator/sampling unit 1064, and frequency synthesizer 1072 are shown. Optionally, these may be utilized by receive processing unit 384B to implement any of the receive processes discussed above in  
5 connection with FIG. 9B.

In operation, the carrier recovery module 376 synchronizes the carriers 1070-1072 to the carrier frequency assigned by the BTS for the subscriber session, i.e. the carrier frequency at which the composite signals 1090-1092 are transmitted. The composite signals from each antenna are demodulated and sampled by the  
10 corresponding one of the demodulator/sampling modules 1064-1060. The outputs of these modules provide inputs to the receive processor/logic 384B. The receive processor implements signal processing techniques which may complement one or more of those discussed on the transmit side (see FIG. 10A). Each composite signal output by the receive processor/logic 384B provides inputs to the spatial/space-time  
15 processor 386 (see FIGS. 7A-D). That processor, using parameters/weights derived using the above-discussed blind/non-blind training techniques, separates the composite signals into the appropriate number of estimated subscriber substreams/datastream(s), e.g. 1096-1098. In configurable embodiments of the spatial/space-time processor, information received from the base stations at the start  
20 of, or during a call session, configures the processor to generate a number of substreams/datastream(s) which correspond to the actual number of substreams/datastream(s) transmitted. Next, the estimated subscriber substreams/datastream(s) are provided as inputs to a similarly configured decoder 388. The decoder maps symbols utilized during the transmission of the  
25 substreams/datastream(s) into their binary equivalent. The decoder outputs the estimated subscriber substreams in their binary equivalent 454-456 to the combiner 390. The combiner reverses the operation performed on the transmit side by the parser, generating thereby an estimated subscriber datastream 176. This datastream is provided to the I/O module 392 for subsequent presentment to the subscriber as for  
30 example, an audio signal, a video signal, a data file, etc. As will be obvious to those skilled in the art, the subscriber unit may be configured to receive more than one channel concurrently.

FIGS. 11A-B show a BTS implementing SM code-division multiple access (CDMA). In CDMA, each subscriber session, whether traditional (unparsed) or spatially processed (parsed), is provided with a distinct code sequence. The datastream/substreams are modulated (spread) onto the distinct code sequence/key code ( $K_n$ ), and the spread signal is, in turn, modulated onto a common carrier. This has the effect of spreading each session across the entire transmission bandwidth. The BTS includes a key/code selector 1100, a transmit processor module 314C (optional), and a final transmit stage 316C. In the embodiment shown, these are part of the above-discussed BTS 132 (see FIG. 1A). Each of these modules is coupled to the control elements shown in FIG. 3, i.e. training module 328, mobility detector 334, memory 322, processor 324, and clock 326. These are coupled via signal/control line 108 to the MSC 106. Shown here for ease of explanation, the mobility detector, as discussed above, is actually implemented on the receive side of the BTS and interacts with the training module 328 to inject training sequences into the SM\_CDMA transmissions.

Subscriber datastream 182 and substreams 454-456 derived from subscriber datastream 176 (see FIGS. 4A-J) are shown as inputs to the key/code selector 1100. The selector 1100, under the direct or indirect control of the MSC 106, selects the appropriate key/code sequence for the datastream(s)/substreams. This is represented in FIG. 11A by a final transmit stage which includes spreader and encoder/modulator clusters, (1110-1111,1120-1121), (1112-1113,1122-1123), and (1114-1115,1124-1125) each of which modulates over a unique key code, respectively 1116-1118, and all of which modulate on a common carrier 1126. Intermediate the code/key selector 1100 and the final transmit stage 316C is the optional transmit processing unit 314C, which may impose on the datastream(s)/substreams additional signal processing, such as that described and discussed above in connection with FIG. 9A.

Within the final transmit stage, two spatially separate antennas 134T-136T are shown, along with an optional antenna array 1140-1142 associated with transmit processing. These are coupled via, respectively, RF stages 1134-1136 and summers (1102-1104),(1106-1108) to separate outputs of each of three spreader encoder/modulator clusters. Each spreader encoder/modulator cluster operates about a distinct key code. Each cluster contains a number of encoder/modulator outputs at least equivalent to the number of spatially separate antennas in the final transmit

stage. Since there are two antennas in the example shown, each cluster contains at least encoding/modulating capability for processing two distinct substreams and for outputting each separately onto a corresponding one of the antennas for spatially separate transmission. The traditional mode datastream 182 is assigned to the second  
5 cluster with the key code 1117. That datastream is output via summer 1104 on antenna 134T. Each of the substreams 454-456, parsed from a common datastream 176 (see FIGS. 4A-J), is passed to a single cluster for spatially separate transmission with a single key code 1116.

FIG. 11B shows a subscriber unit 150 enabled for spatial multiplexing  
10 utilizing CDMA access methodology. That unit includes: first receiver stage 382C, receive processor 384C (optional), spatial/space-time processor 386, decoder 388, combiner 390, I/O module 392, key/code selector 1182, processor 374, carrier recovery module 376, memory 372, and training module 378. The first receiver stage includes antennas 140R-142R, which are coupled via, respectively, RF stages 1152-  
15 1150 to demodulator/sampling modules 1168-1166. Demodulator/sampling modules 1168-1166 operate off a carrier 1172. The output of these is passed to de-spreaders 1162-1160, respectively, which operate off of key code 1176, assigned by the key/code selector 1182 on the basis of control information passed between subscriber unit and base station. Carrier recovery and synchronization may be handled by carrier  
20 recovery module 376, operating in conjunction with carrier generator 1172. Additionally, first receiver stage 382C includes optional antenna array 1146, RF stage 1154, demodulator/sampling unit 1170, carrier generator 1174, de-spreader 1164, and key/code generator 1178. These may be utilized in conjunction with the optional receive processor 384C in the manner discussed above in FIGS. 9B and 10B.

25 In operation, the carrier recovery module 376 synchronizes the carriers 1172-1174 to the carrier assigned by the BTS for the subscriber session, i.e. the carrier at which the composite signals 1190-1192 were transmitted. The composite signals from each antenna are then demodulated and sampled by the corresponding one of the demodulator/sampling modules 1168-1166. Respectively, the outputs of these  
30 modules provide inputs to de-spreaders 1162-1160, where they are de-spread using the key code 1176 assigned for the session. The outputs of the de-spreaders provide inputs to the optional receive processor 384C. The receive processor may implement signal processing techniques which complement one or more of those discussed on

the transmit side (see FIG. 11A). Each composite signal output by the receive processes/logic 384C provides inputs to the spatial/space-time processor 386 (see FIGS. 7A-D). That processor, using parameters/weights derived using the above-discussed blind/non-blind training techniques, separates the composite signals into the appropriate number of estimated subscriber substreams/datastream(s), e.g. 1196-1198. In configurable embodiments of the spatial/space-time processor, information received from the base stations at the start of, or during, a call session configures the processor to generate a number of substreams/datastream(s) which correspond to the actual number of substreams/datastream(s) transmitted. Next, the estimated subscriber substreams/datastream(s) are provided as inputs to a similarly configured decoder 388. The decoder maps symbols utilized during the transmission of the substreams/datastream(s) into their binary equivalent. The decoder outputs the estimated subscriber substreams 454-456 in their binary equivalent to the combiner 390. The combiner reverses the operation performed on the transmit side by the parser, generating thereby an estimated subscriber datastream 176. This datastream is provided to the I/O module 392 for subsequent presentment to the subscriber as, for example, an audio signal, a video signal, a data file, etc. As will be obvious to those skilled in the art, the subscriber unit may be configured to receive more than one channel concurrently.

FIGS. 12A-B show a BTS implementing space-division multiple access (SDMA). In SDMA, each subscriber session, whether traditional (unparsed) or spatially processed (parsed), is transmitted as a shaped beam; a high gain portion of which is electronically directed using beam forming toward a known subscriber, at a known location, within a cell. This has the effect of allowing channel re-use within a single cell by beam forming each subscriber session to a separate segment of a cell.

The BTS includes a beam steering selector 1200, a transmit processor module 314D (optional), and a final transmit stage 316D. In the embodiment shown, these are a part of the above-discussed BTS 132 (see FIG. 1A). Each of these modules is coupled to the control elements shown in FIG. 3, i.e. training module 328, mobility detector 334, memory 322, processor 324, and clock 326. These are coupled via signal/control line 108 to the MSC 106. Subscriber datastream 182 and substreams 454-456, derived from subscriber datastream 176 (See FIGS. 4A-J), are shown as inputs to the beam steering selector 1200. The selector 1200, under the direct/indirect

control of the MSC 106, selects the appropriate direction in which beam steering is to be carried out for each subscriber session and its associated datastream/substreams. Intermediate the beam steering selector 1200 and the final transmit stage 316D is the optional transmit processing unit 314D, which may impose on the  
5 datastream(s)/substreams additional signal processing, such as that described and discussed above in connection with FIG. 9A, with the exception of beam forming.

Within the final transmit stage, two pairs of spatially separate antennas 134TA/B-136TA/B are shown. Additionally, antenna array 1240 associated with transmit processes 314D is shown. The two pairs of antennas are coupled via,  
10 respectively, RF stages 1234,1230,1236,1232 to beam steering module 1202. The beam steering module accepts as inputs the separately encoded and modulated outputs from encoder modulators 1220-1226, each of which operated on a common carrier 1210, and each of which handles a different substream/datastream. The steering of datastream 182 to subscriber 144 (see FIG. 1B), and of substreams 454-456 to  
15 subscriber 150, is accomplished by beam steering unit 1202. That unit, operating with a known location/channel for each subscriber, steers the output beams from the antennas so that they interfere in a manner which maximizes the gain appropriately. At the location of subscriber 144, beam steering results in the composite signal corresponding to datastream 182 reaching a relative maximum, while the gain of the  
20 composite signals corresponding to the substreams 454-456 at that location is minimized. Beam steering also accomplishes the opposite effect at the location of subscriber unit 150.

FIG. 12B shows a subscriber unit 150 enabled for spatial multiplexing utilizing SDMA access methodology. That unit includes: first receiver stage 382D,  
25 receive processor 384D (optional), spatial/space-time processor 386, decoder 388, combiner 390, I/O module 392, processor 374, carrier recovery module 376, memory 372, and training module 378. The first receiver stage includes antennas 140R-142R, which are respectively coupled via RF stages 1252-1250 to demodulator/sampling modules 1262-1260. Demodulator/sampling modules 1262-1260 operate off of a  
30 common carrier 1270. Carrier recovery and synchronization may be handled by carrier recovery module 376 operating in conjunction with carrier generator 1270. Additionally, the first receiver stage may also include: an antenna array 1246, coupled via RF stage 1254 to a demodulator/sampler 1264, and associated carrier module



1272. These operate under the control of receive processes 384D to implement any of the receive processes discussed above in connection with FIG. 9B, 10B and 11B.

In operation, the carrier recovery module 376 synchronizes the carriers 1270-1272 to the carrier at which beam forming is conducted by the BTS(s). The composite signals from each antenna are then demodulated and sampled by the  
5 corresponding one of the demodulator/sampling modules 1268-1266. The outputs of these modules provide inputs to the receive processor 384D. Each composite signal output by the receive processes/logic 384B provides inputs to the spatial/space-time processor 386 (see FIGS. 7A-D). That processor, using parameters/weights derived  
10 using the above-discussed blind/non-blind training techniques, separates the composite signals into the appropriate number of estimated subscriber substreams/datastream(s), e.g. 1296-1298. In configurable embodiments of the spatial/space-time processor, information received from the base stations at the start of, or during, a call session configures the processor to generate a number of  
15 substreams/datastream(s) that correspond to the actual number of substreams/datastream(s) transmitted. Next, the estimated subscriber substreams/datastream(s) are provided as inputs to a similarly configured decoder 388. The decoder maps symbols utilized during the transmission of the substreams/datastream(s) into their binary equivalent. The decoder outputs the  
20 estimated subscriber substreams in their binary equivalent 454-456 to the combiner 390. The combiner reverses the operation performed on the transmit side by the parser, generating thereby an estimated subscriber datastream 176. This datastream is provided to the I/O module 392 for subsequent presentment to the subscriber as, for example, an audio signal, a video signal, a data file, etc. As will be obvious to those  
25 skilled in the art, the subscriber unit may be configured to receive more than one channel concurrently.

Although FIGS. 9-12 show four distinct multiple access methods, it will be obvious to those skilled in the art that each of these may be combined with one or more of the others without departing from the scope of this invention, as well as with  
30 such multiple access methods as: orthogonal frequency division multiple access (OFDMA), wavelength division multiple access (WDMA), wavelet division multiple access, or any other orthogonal division multiple access/quasi-orthogonal division multiple access (ODMA) techniques.

FIGS. 13A-B show the process flow for transmit and receive processing/logic 104\_ associated with an embodiment of the current invention. These processes/logic may be carried out across multiple datastreams, either in parallel, serially, or both. Processing begins at process block 1300 in which the next datastream is detected.

5 Control then passes to decision process 1302. In decision process 1302 a determination is made as to the mode of the datastream. As discussed above, the mode determination may distinguish traditional/spatial, quality of service, bit rate, etc. as well as various combinations thereof. If a determination is made that the mode is traditional, control passes to process 1304. In process 1304 a routing determination is

10 made for the datastream. The routing decision may involve the MSC directing the datastream to an appropriate one of the base stations for transmission. Control then passes to process 1306. In process 1306, the datastream is placed on the appropriate channel within the access protocol implemented on the wireless network. Channel assignment may also be made by the MSC. Control then passes to process 1308 in

15 which the subscriber datastream is transmitted. Next, in decision process 1310, a determination is made as to whether any handoff from one BTS to another is appropriate. If this determination is in the affirmative, control returns to process 1304 for re-routing of the datastream. Alternately, if a negative determination is made in

20 process 1310 that the subscriber is fixed, or still within the cell associated with the transmitting BTS, then control returns to process 1300 for the processing of the next datastream.

If, alternately, in decision process 1302 the mode of the next datastream is determined to be spatial, control passes to process 1320. In process 1320 the datastream is split into a configurable number of substreams. Control is then passed

25 to process 1322. In process 1322 the individual substreams are routed and to one or more base stations for transmission to the subscriber. Control then passes to process 1324. In process 1324, under the direct or indirect control the MSC (see FIG. 1A), the access channel on which to transmit the substreams is selected. That information is communicated to the BTS(s) which are involved in the transmission of the

30 substreams. Control then passes to decision process 1326. In decision process 1326 a determination is made as to whether the intended subscriber is mobile or fixed. If a negative determination is reached, i.e. that the subscriber is fixed, control passes to process 1328. In process 1328, a training sequence either at set-up or during a call

session is generated provided non-blind training protocols are being utilized. The receipt of these training sequences by the subscriber unit allows that unit to derive appropriate weight parameters in the first logic unit of the spatial/space-time processor for separating the composite signals into individual estimated substreams (see FIGS. 7A-D). Alternately, if in decision process 1326 an affirmative determination is reached, i.e. that the subscriber is mobile, then control is passed to process 1330. In process 1330, the frequency or duration of the training sequences inserted into the datastream is increased appropriately. This allows the subscriber unit to continually re-train its spatial/space-time parameters to account for possible changes in the spatial environment brought about by its motion. Control is then passed to process 1332. In process 1332 a determination is made as to the number of substreams that are to be transmitted. The subscriber unit is then signaled as to the number of substreams for which it should configure its spatial/space-time processor and other modules. Control is then passed to process 1334. In process 1334 the selected BTS(s) transmit the selected substreams to the corresponding subscriber unit. Control is then passed to decision process 1336.

In decision process 1336, a decision is made as to whether signal separation at the subscriber unit is adequate. As discussed above, this determination may, for example, be based on feedback from the subscriber unit by monitoring the received signal stream from the subscriber unit, or by monitoring bit error rate (BER) at the transmitting BTS(s). Numerous other methods will be evident to those skilled in the art for making this determination. If this decision is in the negative, i.e. that the subscriber unit is unable to separate the substreams, control returns to process 1320. The process 1320 may now parse the data stream into lesser number of substreams than before, or may do parsing as before, then pass the control to process 1322 for re-routing of the datastream's substreams. Re-routing might, for example, include a change of spatial configuration on a single BTS, or a changeover from single-base to multi-base transmission, as discussed above in connection with FIGS. 4A-J. Alternately, if in decision process 1336 an affirmative determination is reached that the subscriber unit is able to separate the substreams, control passes to decision process 1338. In decision process 1338 a determination is made as to whether a handoff is required. This may result in a partial or full handoff. If that determination is in the negative, e.g. the subscriber unit is fixed, or still within the cell and is capable

of separating the substreams, then control returns to process 1300 for the interception  
of the next datastream. Alternately, if that decision is in the affirmative, control  
returns to process 1320. The process 1320 parses the datastreams as before, and  
passes the control to process 1322 for re-routing of the substreams to one or more  
5 base stations.

FIG. 13B shows the receive processes/logic of a subscriber unit associated  
with an embodiment of the invention. Processing begins at process 1350, in which  
the next datastream is detected. Control is then passed to decision process 1352.  
In decision process 1352, a control signal from the BTS is received indicating the  
10 mode of the transmitted signal, e.g. traditional/spatial, and in the latter case, the  
number of substreams to be generated from the composite signals received. If the  
composite signals are to be treated as carrying a traditional datastream, control is  
passed to process 1354. In process 1354 the appropriate channel on which to receive  
the composite signal is assigned. Channel assignment may occur: during call setup,  
15 during a change in spatial configuration, or during a change from single-base to multi-  
base transmission, for example. Control is then passed to process 1356. In process  
1356 the composite signals are received and appropriately processed by the associated  
modules of the subscriber unit (see FIG. 3). Control is then passed to decision  
process 1358. In decision process 1358, any training sequences and update of signal  
20 processing parameters that may be required are performed. Control is then passed to  
decision process 1360 for a determination as to whether signal quality and/or strength  
is adequate. If an affirmative determination is reached, e.g. that quality and/or  
strength is adequate, then control returns to process 1350 for the processing of the  
next datastream. Alternately, if a negative determination is reached, then control is  
25 passed to process 1362. In process 1362 signaling of the BTS(s) that signal strength  
or quality is not acceptable is accomplished. In an embodiment of the invention, the  
subscriber unit signals the BTS that signal strength is no longer suitable for reception,  
or that signal separation, in the case of spatial transmissions, is no longer adequate.  
Control then returns to process 1350 for the processing of the next datastream.

30 If, alternately, in decision process 1352 the control signal from the BTS  
indicates that the mode of the incoming composite signals is spatial, control is passed  
to process 1370. In process 1370, control information received by the subscriber unit  
indicates the number of substreams for which the spatial processor, and other modules

of the receive portion of the subscriber unit, are to be configured. Control is then passed to process 1372. In process 1372 access parameters, e.g. channel, for the transmission from the BTS(s) to the subscriber unit are passed to the subscriber unit. Control then passes to process 1374. In process 1374 the composite signals are received and processed into corresponding estimated subscriber substreams. Control then passes to decision process 1376. In decision process 1376 a determination is made as to whether any training sequence is present in the datastream. This embodiment of the invention therefore implements non-blind training. Other embodiments of the invention implementing blind training methods need not implement this particular act. If, in decision process 1376 a negative determination is reached, i.e. that no training sequences are present, control returns to process 1350. Alternately, if in decision process 1376 an affirmative determination is reached, i.e. that a training sequence is present, then control is passed to process 1378. In process 1378, evaluation of the training sequence is performed and new weights registered within the spatial/space-time processor for separating the training sequences. Control is then passed to decision process 1380 for evaluation of the training sequences, then passed to decision process 1382 for a determination of whether the training sequences can be separated adequately. If an affirmative decision is reached, then control returns to decision process 1350. Alternately, if the separation is not adequate, then control passes to process 1384. In process 1384, a control signal is sent to the BTS indicating that a change in spatial configuration is required. The BTS(s) might respond by changing spatial configuration from single to multi-base, by changing the number or spatial configuration of the antennas utilized at a single base, by changing a channel, etc. Control then returns to process 1350 for processing of the next datastream.

The foregoing description of a preferred embodiment of the invention has been presented for purposes of illustration and description. It is not intended to be exhaustive or to limit the invention to the precise forms disclosed. Obviously many modifications and variations will be apparent to practitioners skilled in this art. It is intended that the scope of the invention be defined by the following claims and their equivalents.

It should also be apparent that the described subscriber units may be used in a wide variety of other applications without departing from the scope of the present

invention. One such application contemplates the use of the described subscriber units in network access units that are used provision extend or otherwise supplement the range of existing high speed telephone or cable networks. By way of example, a hybrid DSL/wireless link is diagrammatically illustrated in Fig. 14. As is well known in the telecommunications art, in conventional high speed xDSL networks, high speed communications are made between a head end DSL modem (typically located at a central office (CO) or optical network unit (ONU)) and a remote DSL modem located on a customer's premises. The link between the central and remote modems is made on ordinary twisted pair wires. Thus xDSL system have the strong advantage of allowing high speed communications using existing wiring infrastructure. However, twisted pair wiring has significant signal attenuation and therefore, it is typically difficult or impossible to provide DSL service to customers who are located too far (e.g. more than 2 or 3 miles) from the central office/ONU. Further, even among customers within the coverage area, the loading coils and the bridge taps which are used around the binders of twisted pair wires that connect the modems, as well as other potential obstacles may make DSL technology difficult to implement in many circumstances.

In the embodiment illustrated in Figure 14, the range and/or accessibility of the DSL network is extended by placing a head end DSL modem 1430 in proximity to the remote DSL modem 1425. A suitable xDSL protocol (such as ADSL, VDSL, etc.) and modulation technique (such as DMT, DWMT, CAPs, etc.) is used to communicate between the remote DSL modem 1425 located at the customer premises and the head end DSL modem 1430 located at an appropriate location that is within range of the customer premises. By way of example, the head end DSL modem 1430 may be located at the terminal server 1410 on a nearby telephone pole 1432 from which the twisted pair drop 1435 originates that serves the customer premises. The head end DSL modem 1430 then provides the raw input data stream to the network access unit (subscriber unit) 1440 that communicates with appropriate BTSs 1445 as described above. Of course, in embodiments where a plurality of different remote DSL modems within the same neighborhood are being serviced, the head end DSL modem may multiplex the data streams from the various xDSL connections.

It is noted that the location of the described network access units may be widely varied based on the needs of a particular system. One advantage to placing the

network access units at the terminal servers is that it provides a readily accessible location where installation is relatively easy. Also, terminal servers are often located on a telephone pole as illustrated in Figure 14. This may be advantageous in that top telephone poles are relatively higher as compared to many other potential deployment  
5 locations, which may provide a clearer path between the network access unit 1440 and the BTS transceiver. This, of course may result in increased data speeds. It should be appreciated that the described arrangements can bring DSL service to a wide variety of locations using the POTS (plain old telephone service) infrastructure.

Referring next to Fig. 15 another embodiment of the present invention is  
10 illustrated. In this embodiment, the network access unit 1440 is connected to a plurality of cable modems 1460 via an appropriate cable 1470. Any suitable cable including hybrid fiber co-axial (HFC) cables, co-axial cables or fiber cables may be used as cable 1470. Like the previously described hybrid DSL link, the illustrated hybrid cable link provides the possibility of expanding the range of high speed data  
15 communications using existing infrastructure.

As suggested above, the described subscriber unit can be used as a node in virtually any network to facilitate communications between that network and other devices and/or networks. For example, with the growing popularity of home networks, a subscriber unit can be used as a node in a home network. Alternatively, a  
20 subscriber can be used in office networks and/or any other type of local area, wide area, or other networks.

Another networking concept that has attracted some attention lately is vehicle based networking. For example, people have contemplated wiring carriers such as buses, airplanes, ships and other vehicles with networks that provide multiple nodes  
25 within the vehicle for use by passengers. The described spatial multiplexing based subscriber units which take advantage of a wireless link are particularly well adapted to providing high speed access for any vehicle based network.

Referring next to Fig. 16, yet another deployment possibility for the subscriber units will be described. In the embodiment illustrated in Fig. 16, the subscriber unit  
30 1601 is utilized as a wireless interface for a repeater BTS 1610 in a cellular network. Various parties have proposed and implemented the concept of using repeater BTSs in cellular networks. Generally, a repeater BTS 1610 is designed to extend the coverage

area of a master BTS 1620 and/or cover dead spots in the master BTS's coverage area. The repeater BTS simply repeats the signals being transmitted by the master BTS. The link between the master BTS and the repeater link can be either a wireless link or a wired link. Given the high data rates that are possible using the spatial  
5 multiplexing based subscriber units, it should be apparent that the described subscriber units are particularly well suited for use in repeater BTSs.

Although a few specific deployments have been described, it should be appreciated that the described spatial multiplexing based subscriber units may be deployed in a wide variety of other situations as well.

10



## CLAIMS

1. A wireless cellular network for transmitting subscriber datastreams to corresponding ones among a plurality of subscriber units located within the cellular network, and said wireless cellular network comprising:
- 5 base stations each including spatially separate transmitters for transmitting in response to control signals, selected substreams of each subscriber datastream on an assigned channel of a multiple access protocol; and
- logic communicating with each of the base stations and the logic for assigning an available channel on which to transmit each subscriber datastream, for routing at
- 10 least a substream of each datastream to at least a selected one of the base stations and for generating control signals to configure the at least a selected one of the base stations to transmit the selected substreams to a corresponding one among the plurality of subscriber units on the assigned channel.
- 15 2. The wireless cellular network of Claim 1 wherein the logic is arranged for changing a spatial transmission configuration from a first transmitting base station to at least the first base station together with a second transmitting base station responsive to a determination that a change of a spatial reception configuration is required in order to resolve the selected substreams at the corresponding one among
- 20 the plurality of subscriber units.
3. The wireless cellular network of either of claims 1 and 2 wherein the logic is arranged for changing the spatial reception configuration from a first receiving base station to at least a second base station together with a third base station responsive to
- 25 a determination that a change of a spatial reception configuration is required in order to resolve the selected substreams at the corresponding one among the plurality of subscriber units.
4. The wireless cellular network of any of the preceding claims wherein the logic
- 30 further comprises a parser for parsing each datastream into substreams.

5. The wireless cellular network of Claim 4, wherein:  
the parser includes responsiveness to a mode signal to parse each datastream into a variable number of substreams and to avoid parsing of each datastream; and  
5 the parser is responsive to a modulation rate of each substream.
6. The wireless cellular network of Claim 4, wherein the logic further comprises a router for routing the substreams to at least a selected one of the base stations and each of the base stations further comprises a selector responsive to the control signals  
10 generated by the logic to inject a routed one of the substreams onto the channel assigned by the logic.
7. The wireless cellular network of Claim 6, wherein each of the base stations further comprises a selector responsive to the control signals generated by the logic to  
15 inject routed ones of the substreams onto both the channel assigned by the logic as well as onto selected ones of the spatially separate transmitters.
8. The wireless cellular network of any of the preceding claims wherein the logic further comprises:  
20 a detector to detect modes of the subscriber datastreams from the first network and to generate a mode signal corresponding to the mode of each of the subscriber datastreams;  
a parser responsive to the mode signal to parse the datastream into a variable number of substreams and to avoid parsing of the datastream; and  
25 a router for routing both an unparsed datastream as well as a variable number of substreams to at least a selected one of the base stations.
9. The wireless cellular network of Claim 8, wherein the modes of the datastreams include voice mode and data mode and wherein further the parser is

responsive to a voice mode signal avoids parsing of the datastream, and responsive to a data mode signal parses the datastream into a variable number of substreams.

10. The wireless cellular network of Claim 8, wherein the modes of the  
5 datastreams include high bit rate and low bit rate and wherein further the parser avoids parsing of a low bit rate datastream, and parses a high bit rate datastream into a variable number of substreams.

11. The wireless cellular network of Claim 8, wherein the modes of the  
10 datastreams include low QoS requirement and high QoS requirement and wherein further the parser avoids parsing a datastream with a low QoS requirement, and parses a datastream with a high QoS requirement into a variable number of substreams.

15 12. The wireless cellular network of any of Claims 8-11, wherein each of the base stations further comprises:

a selector responsive to the control signals generated by the logic to inject  
routed ones of the substreams as well as the unparsed datastream onto both the  
channel assigned by the logic as well as a selected one of the spatially separate  
20 transmitters.

13. The wireless cellular network of any of the preceding claims wherein each of  
the base stations further comprises a training module for injecting a training sequence  
into the transmissions of the spatially separable transmitters.

25

14. The wireless cellular network of any of the preceding claims, wherein each of  
the base stations further comprises:

spatially separate receivers for receiving composite signals resulting from the  
spatially separate transmission of spatially separate source signals corresponding to

selected substreams of an uplink subscriber datastream from selected ones of the subscriber units, on an assigned channel of the multiple access protocol;

5 a spatial processor configurable in response to the control signal to separate the composite signals into estimated source signals based on information obtained during the transmission of known data patterns from the selected ones of the subscriber units; and

a combiner for combining the estimated source signals into a corresponding uplink subscriber datastream.

10 15. The wireless cellular network of Claim 14, wherein the spatial processor further comprises:

a configurable logic responsive to the control signal to vary both a number of the composite signals separated as well as the number of the estimated source signals.

15 16. The wireless cellular network of any of the preceding claims, wherein each of the base stations further comprise:

mobility detectors for determining a mobility of each of the subscriber units and generating a mobility signal; and

20 a training module responsive to the mobility signal for varying at least one of: an injection interval and duration of a training sequence into the transmissions of the spatially separable transmitters.

17. The wireless cellular network of any of the preceding claims, wherein each of the base stations further comprises transmit processes selected from at least one of a group of transmit processes consisting of: diversity, space coding, space time coding and beam forming.

18. A subscriber unit for use in a cellular system with base stations each including spatially separate transmitters for transmitting selected substreams of at least one of a

plurality of subscriber downlink datastreams on an assigned channel of a multiple access protocol, and the subscriber unit comprising:

5           spatially separate receivers for receiving on the assigned channel of the multiple access protocol composite signals resulting from the spatially separate transmission the selected substreams;

          a spatial processor to separate the composite signals into estimated subscriber substreams, and to signal the base stations when a change of a spatial transmission configuration is required in order to resolve the composite signals into estimated substreams; and

10           a combiner for combining the estimated substreams into a corresponding subscriber datastream.

19.       The arrangement of Claim 18, wherein the spatial processor further comprises responsiveness to a control signal from the base station to vary a number of estimated  
15       subscriber substreams.

20.       The arrangement of Claim 18 or 19, wherein the spatially separate receivers further comprise:

20           a first selector responsive to the control signal to assign a channel on which to operate said spatially separate receivers; and

          a second selector responsive to the control signal to enable selected ones of the spatially separate receivers on the assigned channel to receive the composite signals.

21.       The arrangement of any of Claims 18-20, wherein the spatial processor further  
25       comprises a configurable logic responsive to the control signal to vary both a number of the composite signals separated as well as the number of the estimated source signals and to evaluate the composite signals over time.

22. The arrangement of any of Claims 18-21, wherein the spatial processor further comprises an evaluator to evaluate the estimated source signals during a transmission interval in which at least one of the base stations transmits the known data patterns and to initiate the signal to the at least one of the base stations when a change of the spatial transmission configuration is required.

5

23. The arrangement of any of Claims 18-22, wherein the combiner includes responsiveness to the control signal to vary a number of estimated source signals combined into a corresponding subscriber datastream.

10

24. The arrangement of any of Claims 18-23, further comprising:  
a parser for parsing an uplink subscriber datastream into substreams; and  
spatially separate transmitters for transmitting the substreams of the uplink subscriber datastream on an assigned channel of a multiple access protocol.

15

25. The arrangement of any of Claims 18-24, wherein the subscriber unit further comprises receive processors from at least one of a group of receive processes consisting of diversity, space decoding, space-time decoding, beam forming and interference canceling.

20

26. A wireless cellular network for transmitting subscriber downlink datastreams from a first network to subscribers located within the wireless cellular network, and said wireless cellular network comprising:

base stations each configured for spatially separate transmission of selected substreams of each subscriber downlink datastream on an assigned channel of a multiple access protocol;

25

subscriber units each configured for spatially separate reception on the assigned channel of the selected substreams and for combining the substreams into the corresponding subscriber datastream; and

a logic communicating with each of the base stations and to the first network and the logic configured to route at least a substream of each subscriber downlink datastream to at least a selected one of the base stations and further configured to vary the routing between a single base station and multiple base stations to vary a spatial transmission configuration of the selected substreams.

27. A wireless cellular network for receiving subscriber datastreams at corresponding ones among a plurality of base stations located within the cellular network, and said wireless cellular network comprising:

10 a plurality of subscriber units each including spatially separate transmitters for transmitting, in response to control signals, selected substreams of each subscriber datastream on an assigned channel of a multiple access protocol; and

logic communicating with each of the base stations and the logic for generating control signals to configure selected ones of the base stations to receive composite signals resulting from the spatially separate transmission of the selected substreams from a corresponding one among the plurality of subscriber units on the assigned channel, for converting the composite signals into estimate substreams and for combining the estimated substreams of each subscriber datastream into each subscriber datastream.

28. The logic of Claim 27, further for changing the spatial reception configuration from a first receiving base station to at least the first base station together with a second base station responsive to a determination that a change of a spatial reception configuration is required in order to resolve the composite signals into estimated substreams.

28. The logic of Claim 27 or 28, further for changing the spatial reception configuration from a first receiving base station to at least a second base station together with a third base station responsive to a determination that a change of a spatial reception configuration is required in order to resolve the composite signals into estimated substreams.

29. A wireless cellular network for transmitting subscriber datastreams to corresponding ones among a plurality of subscriber units located within the cellular network, and said wireless cellular network comprising:

- 5 base stations each including at least one transmitter for transmitting, in response to control signals, selected substreams of each subscriber datastream on an assigned channel of a multiple access protocol; and
- logic communicating with each of the base stations and the logic for assigning an available channel on which to transmit each subscriber datastream, for routing at  
10 least a substream of each datastream to at least a selected one of the base stations and for generating control signals to configure the at least a selected one of the base stations to transmit the selected substreams to a corresponding one among the plurality of subscriber units on the assigned channel.

- 15 30. The arrangement of Claim 29, wherein the logic is further arranged for changing a spatial transmission configuration from a first transmitting base station to at least the first base station together with a second transmitting base station responsive to a determination that a change of a spatial reception configuration is required in order to resolve the selected substreams at the corresponding one among  
20 the plurality of subscriber units.

31. The arrangement of Claim 29 or 30, wherein the logic is further arranged for changing the spatial reception configuration from a first receiving base station to at least a second base station together with a third base station responsive to a  
25 determination that a change of a spatial reception configuration is required in order to resolve the selected substreams at the corresponding one among the plurality of subscriber units.

32. The arrangement of any one of Claims 29-31 wherein the logic is further  
30 arranged for changing a spatial transmission configuration from a first transmitting base station together with a second transmitting base station to at least the first



transmitting base station together with a third transmitting base station responsive to a determination that a change of a spatial reception configuration is required in order to resolve the selected substreams at the corresponding one among the plurality of subscriber units.

5

33. The arrangement of any one of Claims 29-32, wherein the logic is further arranged for changing a spatial transmission configuration from a first transmitting base station together with a second transmitting base station to at least the third transmitting base station together with a fourth transmitting base station responsive to a determination that a change of a spatial reception configuration is required in order to resolve the selected substreams at the corresponding one among the plurality of subscriber units.

10

34. A method for transmitting subscriber downlink datastreams from base stations to corresponding ones among a plurality of subscriber units, and said method for transmitting comprising the acts of:

15

routing at least a substream of each subscriber downlink datastream to selected ones of the base stations;

transmitting the at least a substream of each subscriber downlink datastream from the selected ones of the base stations on an assigned channel of a multiple access protocol; and

20

re-routing at least a substream of each subscriber downlink datastream between a single base station and multiple base stations responsive to a determination that a change of a spatial transmission configuration of the at least a substream of each subscriber downlink datastream signal is required.

25

35. The method of Claim 34, wherein the at least a substream comprises at least one of: a whole subscriber downlink datastream and substreams of the subscriber downlink datastream.

30

36. The method of Claim 34 or 35, wherein the routing act and re-routing acts further comprise the acts of:

parsing each of the subscriber downlink datastreams into a configurable number of substreams; and

5 configuring the at least a selected one of the base stations to transmit selected substreams of each subscriber downlink datastream to a corresponding one among the plurality of subscriber units on the assigned channel.

37. The method of Claim 36, wherein the parsing act further comprises the acts of:

10 determining a mode for each of the subscriber downlink datastreams;

parsing the subscriber downlink datastream into a plurality of substreams responsive to a first mode determination in said act of determining; and

avoiding the parsing of the subscriber downlink datastream responsive to a second mode determination in said act of determining.

15

38. The method of Claim 37, wherein the first mode and the second mode correspond to at least one of: a transmission rate of each of the subscriber downlink datastreams, and a data type of each of the subscriber downlink datastreams.

20 39. The method as recited in any of Claims 34-38, wherein the determination that a change of a spatial transmission configuration is required corresponds to a signal generated by a corresponding one of the subscriber units.

40. The method as recited in any of Claims 34-39, further comprising the acts of:

25 receiving at a corresponding one among the plurality of subscriber units signals generated in said transmitting act;

determining a number of substreams to be derived from the signals;

separating the signals into the number of substreams determined in said act of determining; and

combining the substreams into a corresponding subscriber downlink  
datastream.

41. A method of receiving subscriber downlink datastreams transmitted from a  
5 plurality of spatially separate transmitters, comprising the acts of:

receiving signals generated from at least one of the plurality of spatially  
separate transmitters;

determining a number of substreams to be derived from the signals;

10 separating the signals into the number of substreams determined in said act of  
determining; and

combining the substreams into a corresponding subscriber downlink  
datastream.

42. The method Claim 41, wherein said separating act further comprises the acts  
15 of:

determining that a change of a spatial transmission configuration is required in  
order to separate the number of substreams; and

changing the spatial transmission configuration responsive to said act of  
determining.

20

43. A wireless cellular network for transmitting subscriber datastreams to  
corresponding ones among a plurality of subscriber units located within the cellular  
network, and said wireless cellular network comprising:

25 means for routing at least a substream of each subscriber downlink datastream  
to selected ones of the base stations;

means for transmitting the at least a substream of each subscriber downlink  
datastream from the selected ones of the base stations on an assigned channel of a  
multiple access protocol; and

means for re-routing the at least a substream of each subscriber downlink datastream between a single base station and multiple base stations responsive to a signal from a corresponding one of the subscriber units requesting a change of spatial transmission configuration.

5

44. A subscriber unit for use in a cellular system with base stations each including spatially separate transmitters for transmitting selected substreams of at least one of a plurality of subscriber downlink datastreams on an assigned channel of a multiple access protocol, and the subscriber unit comprising:

10 means for receiving signals generated from at least one of the plurality of spatially separate transmitters;

means for determining a number of substreams to be derived from the signals;  
 means for separating the signals into the number of substreams determined in said act of determining;

15 means for combining the substreams into a corresponding subscriber downlink datastream; and

means for signaling the base when a change of a spatial transmission configuration is required in order to resolve the composite signals into estimated substreams.

20

45. A wireless cellular remote unit for transmitting a datastream to at least one base station that is part of a cellular network, the wireless cellular remote unit comprising:

a plurality of spatially separate antennas;

25 a transmitter for transmitting a plurality of substreams of the datastream on an assigned channel or slot of a multiple access protocol, the transmitter being arranged to apply each substream to an associated one of the spatially separate antennas, the transmitter further being responsive to a control signal from the base station to vary the number of applied substreams.

30

46. The unit of Claim 45, wherein the remote unit communicates with a first network to provide the first network with access to the cellular network.

47. The unit of Claim 46 wherein the first network is one selected from the group  
5 consisting of a home network, a vehicle based network and a local area network.

48. A unit as recited in any one of claims 45-47 wherein the subscriber unit is incorporated into a bridge or router to provide a wireless bridge or router.

10 49. The unit of any one of claims 45-48, wherein the remote unit is one of a fixed unit and a mobile unit.

50. The unit of any one of claims 45-49, wherein the remote unit further comprises transmit processes from at least one of a group of transmit processes  
15 consisting of diversity, space coding, space-time coding, space frequency coding, beam forming and interference canceling.

51. The unit of any one of claims 45-50, wherein the transmitter includes a parser for parsing the datastream into the substreams.

20

52. The wireless cellular remote unit of Claim 51, wherein the parser is responsive to at least one of:

a mode signal to parse the datastream into a variable number of substreams and to avoid parsing of each datastream; and

25 a modulation rate of each substream.

53. The unit of any one of claims 45-52 further comprising a selector arranged to inject a routed one of the substreams onto the assigned channel.

54. A wireless cellular remote unit for transmitting a datastream to at least one base station that is part of a cellular network, the wireless cellular remote unit comprising:
- 5 a plurality of spatially separate antennas;
- a transmitter for transmitting a plurality of substreams of the datastream on an assigned channel or slot of a multiple access protocol, the transmitter being arranged to apply each substream to an associated one of the spatially separate antennas;
- a detector to detect a mode of the datastream and to generate a corresponding
- 10 mode signal; and
- a parser responsive to the mode signal to parse the datastream into a variable number of substreams and to avoid parsing of the datastream.
55. The wireless cellular remote unit of Claim 54, wherein the modes of the
- 15 datastream includes at least one of:
- voice mode and data mode and wherein further the parser responsive to a voice mode signal avoids parsing of the datastream, and responsive to a data mode signal parses the datastream into a variable number of substreams;
- high bit rate and low bit rate and wherein further the parser avoids parsing of a
- 20 low bit rate datastream, and parses a high bit rate datastream into a variable number of substreams; and
- low QoS requirement and high QoS requirement and wherein further the parser avoids parsing a datastream with a low QoS requirement, and parses a datastream with a high QoS requirement into a variable number of substreams.
- 25
56. A wireless cellular remote unit for receiving a downlink datastream from and transmitting an uplink datastream to at least one base station that is part of a cellular network, the wireless cellular remote unit comprising:
- a plurality of spatially separate antennas;

a transmitter for transmitting a plurality of uplink substreams of the uplink datastream on an assigned channel or slot of a multiple access protocol, the transmitter being arranged to apply each uplink substream to an associated one of the spatially separate antennas;

5 a receiver including a spatial processor arranged to separate a composite downlink signal received by the spatially separate antennas into estimated substreams, and a combiner for combining the estimated substreams into a corresponding subscriber datastream, the receiver being arranged to signal the base stations when a change of a spatial transmission configuration is required in order to resolve the  
10 composite signals into estimated substreams.

57. A wireless cellular remote unit as recited in claim 56 wherein the remote unit takes the form of a network access unit that is a node in a network that facilitates communication outside of the network.

15

58. A method of transmitting a datastream from a remote unit to at least one cellular base station in a cellular network, the method comprising:

forming a plurality of substreams from the datastream, wherein the number of substreams formed is determined in response to a control signal received from one of  
20 the base stations; and

transmitting the substreams in parallel from spatially separate antennas on an assigned channel or slot using a multiple access protocol.

59. A method of communicating between a remote location and one or more base  
25 stations in a cellular network, the method comprising:

transmitting a datastream from the remote location to a wireless access unit over a wired connection using a communications protocol selected from the group consisting of an xDSL protocol, a cable modem protocol and a networking protocol;

forming a plurality of substreams from the datastream; and

transmitting the substreams to the one or more base stations in parallel from spatially separate antennas on an assigned channel or slot using a multiple access protocol.

5 60. A wireless cellular remote unit for receiving a downlink datastream from and transmitting an uplink datastream to at least one base station that is part of a cellular network, the wireless cellular remote unit comprising:

a plurality of spatially separate antennas;

10 transmission means for transmitting a plurality of uplink substreams of the uplink datastream on an assigned channel or slot of a multiple access protocol, the transmitter being arranged to apply each uplink substream to an associated one of the spatially separate antennas; and

15 receiver means arranged to separate a composite downlink signal received by the spatially separate antennas into estimated substreams, and combine the estimated substreams into a corresponding subscriber datastream.

61. A wireless cellular remote unit as recited in claim 60 wherein:

20 the remote unit is arranged to signal the base stations when a change of a spatial transmission configuration is required by the receiver in order to resolve the composite signals into estimated substreams; and

the transmitter is responsive to a control signal from the base station to vary the number of applied substreams.

25 62. A repeater base station suitable for use in conjunction with a master base station that is part of a cellular network, the repeater base station including:

a slave base station; and

a wireless interface unit comprising,

a plurality of spatially separate antennas; and



5 a transmitter for transmitting a plurality of substreams of a datastream on an assigned channel or slot of a multiple access protocol, the transmitter being arranged to apply each substream to an associated one of the spatially separate antennas, the transmitter further being responsive to a control signal from the master base station to vary the number of applied substreams.

63. A communications network comprising:

a master station controller;

10 at least one base station controller that communicates with the master station controller;

a plurality of base station, each base station being arranged to communicate with an associated one of the base station controllers, wherein at least one of the base stations is designated as a master base station; and

a repeater base station as recited in claim 62.

15

64. A unit for use in a communications network that delivers DSL service to customers, the unit comprising:

a head end DSL modem arranged to communicate with a remotely located DSL modem using a DSL protocol; and

20 a wireless access unit comprising arranged to receive a datastream from the head end DSL modem, the wireless access unit including, a plurality of spatially separate antennas and a transmitter for transmitting a plurality of substreams of the datastream on an assigned channel or slot of a multiple access protocol, the transmitter being arranged to apply each substream to an associated one of the  
25 spatially separate antennas.

65. A unit for use in a communications network that delivers DSL service to customers, the unit comprising:

a head end DSL modem arranged to communicate with a remotely located DSL modem using a DSL protocol; and

a wireless access unit comprising,

5 spatially separate receivers for receiving on an assigned channel of a multiple access protocol composite signals resulting from spatially separate transmission selected substreams communicated from a base station in the communications network;

a spatial processor to separate the composite signals into estimated slave substreams; and

10 a combiner for combining the estimated substreams into a corresponding slave datastream, wherein the slave datastream is passed to the head end DSL modem for transmission to a remotely located DSL modem using a DSL protocol.

66. A unit for use in a communications network that delivers high speed data delivery service to customers, the unit comprising:

a head end cable modem unit arranged to communicate with a remotely located cable modem over a cable;

20 a wireless access unit comprising arranged to receive a datastream from the head end cable modem, the wireless access unit including, a plurality of spatially separate antennas and a transmitter for transmitting a plurality of substreams of the datastream on an assigned channel or slot of a multiple access protocol, the transmitter being arranged to apply each substream to an associated one of the spatially separate antennas.

25 67. A unit for use in a communications network that delivers high speed data delivery service to customers, the unit comprising:

a head end cable modem unit arranged to communicate with a remotely located cable modem over a cable;

a wireless access unit comprising,

spatially separate receivers for receiving on an assigned channel of a multiple access protocol composite signals resulting from spatially separate transmission selected substreams communicated from a base station in the communications network;

5 a spatial processor to separate the composite signals into estimated slave substreams; and

a combiner for combining the estimated substreams into a corresponding slave datastream, wherein the slave datastream is passed to the head end cable modem for transmission to a remotely located cable modem.

10

68. A unit as recited in claim 66 or 67 wherein the cable is one selected from the group consisting of a hybrid fiber co-axial cable, a co-axial cable and a fiber cable.

69. A repeater base station suitable for use in conjunction with a master base station  
15 that is part of a cellular network, the repeater base station including:

a slave base station; and

a wireless interface unit comprising,

20 spatially separate receivers for receiving on an assigned channel of a multiple access protocol composite signals resulting from spatially separate transmission selected substreams communicated from a master base station;

a spatial processor to separate the composite signals into estimated slave substreams; and

25 a combiner for combining the estimated substreams into a corresponding slave datastream, wherein the slave datastream is passed to the slave base station for transmission by the slave base station.

70. A communications network comprising:

a master station controller;

at least one base station controller that communicates with the master station controller;

a plurality of base station, each base station being arranged to communicate with an associated one of the base station controllers, wherein at least one of the base stations is designated as a master base station; and

a repeater base station as recited in claim 69.

71. A unit as recited in claim 64 or 65 wherein the unit is coupled to a terminal server in a POTS communications network such that a first link between the remotely located DSL modem and the head end DSL modem takes the form of twisted pair wiring and a second link between the wireless access unit and a base station takes the form of a wireless link.

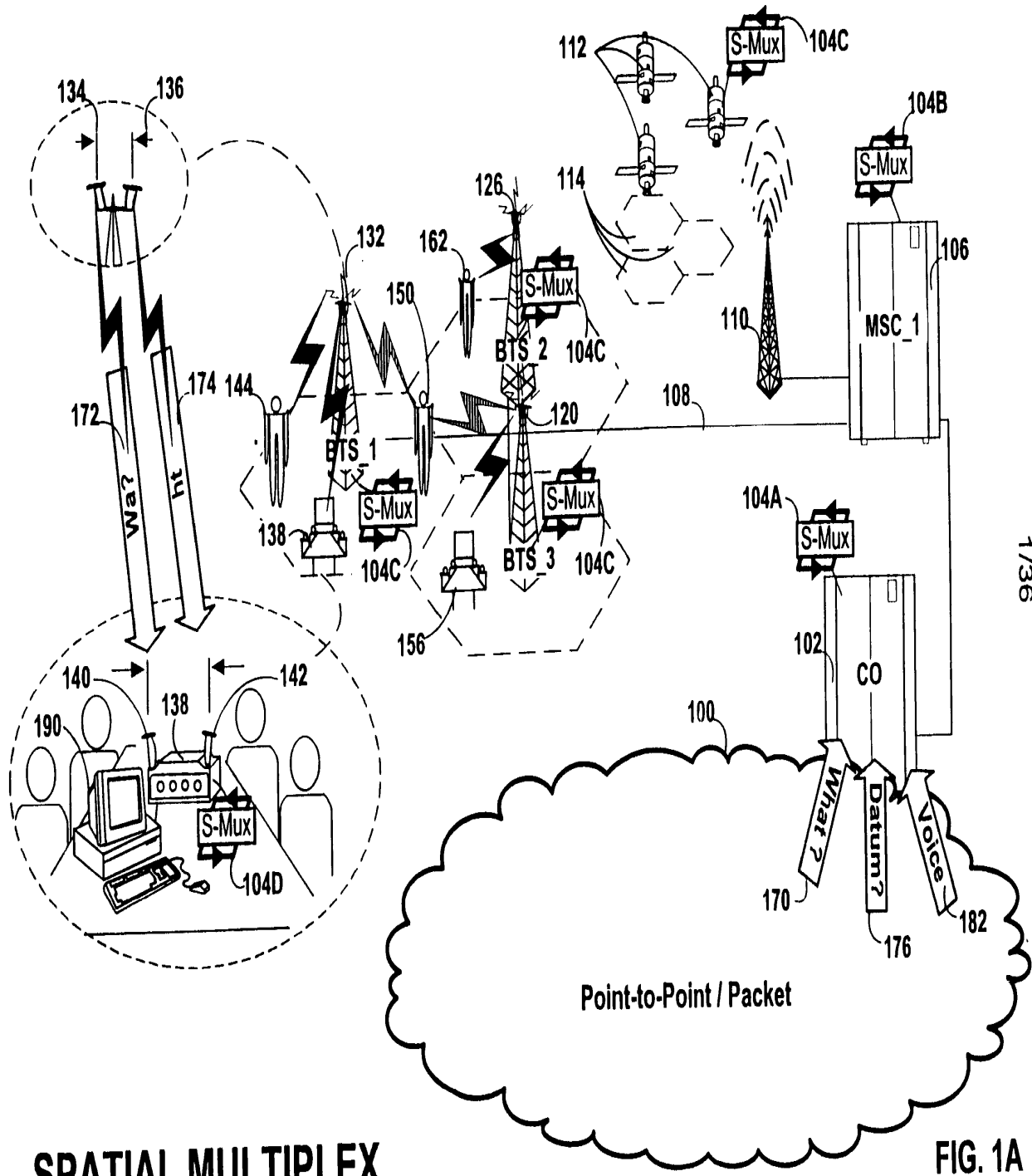
72. An arrangement as recited in any of the preceding claims, wherein the multiple access protocol is selected from at least one of a group of multiple access protocols consisting of: code-division multiple access, frequency-division multiple access, time-division multiple access, space-division multiple access, orthogonal frequency division multiple access (OFDMA), wavelength division multiple access (WDMA), wavelet division multiple access, orthogonal division multiple access (ODMA) and quasi-orthogonal division multiple access (ODMA) techniques.

73. An arrangement as recited in any of the preceding claims, wherein the assigned channel comprises, within a transmission bandwidth, at least one of: a frequency-division, a time-division, a spatial-division, a code-division, orthogonal frequency division multiple access (OFDMA), wavelength division multiple access (WDMA), wavelet division multiple access or any other orthogonal division multiple access (ODMA)/quasi-orthogonal division multiple access techniques.

74. The arrangement of any of the preceding claims wherein the base stations receive the plurality of subscriber downlink datastreams from at least one of a group of networks consisting of: a public switched telephone network, a local area network, a wide area network, a satellite network, an adhoc network, a virtual private network,  
5 an intranet and an internet.

75. The arrangement of any of the preceding claims, wherein the base stations include satellites.

10 76. An arrangement as recited in any of the preceding claims wherein the subscriber unit is incorporated into a bridge or router to provide a wireless bridge or router.



SPATIAL MULTIPLEX

FIG. 1A

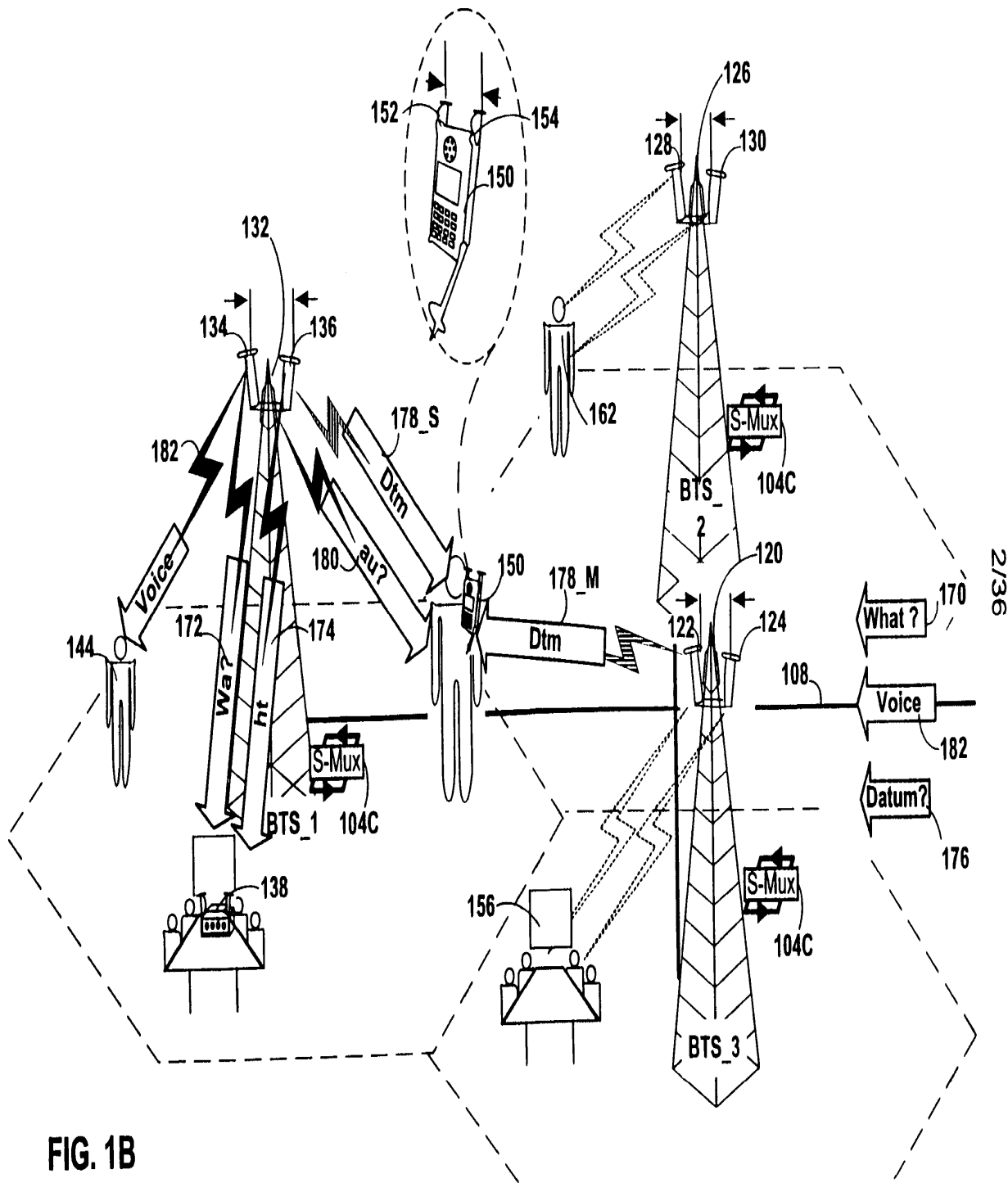


FIG. 1B

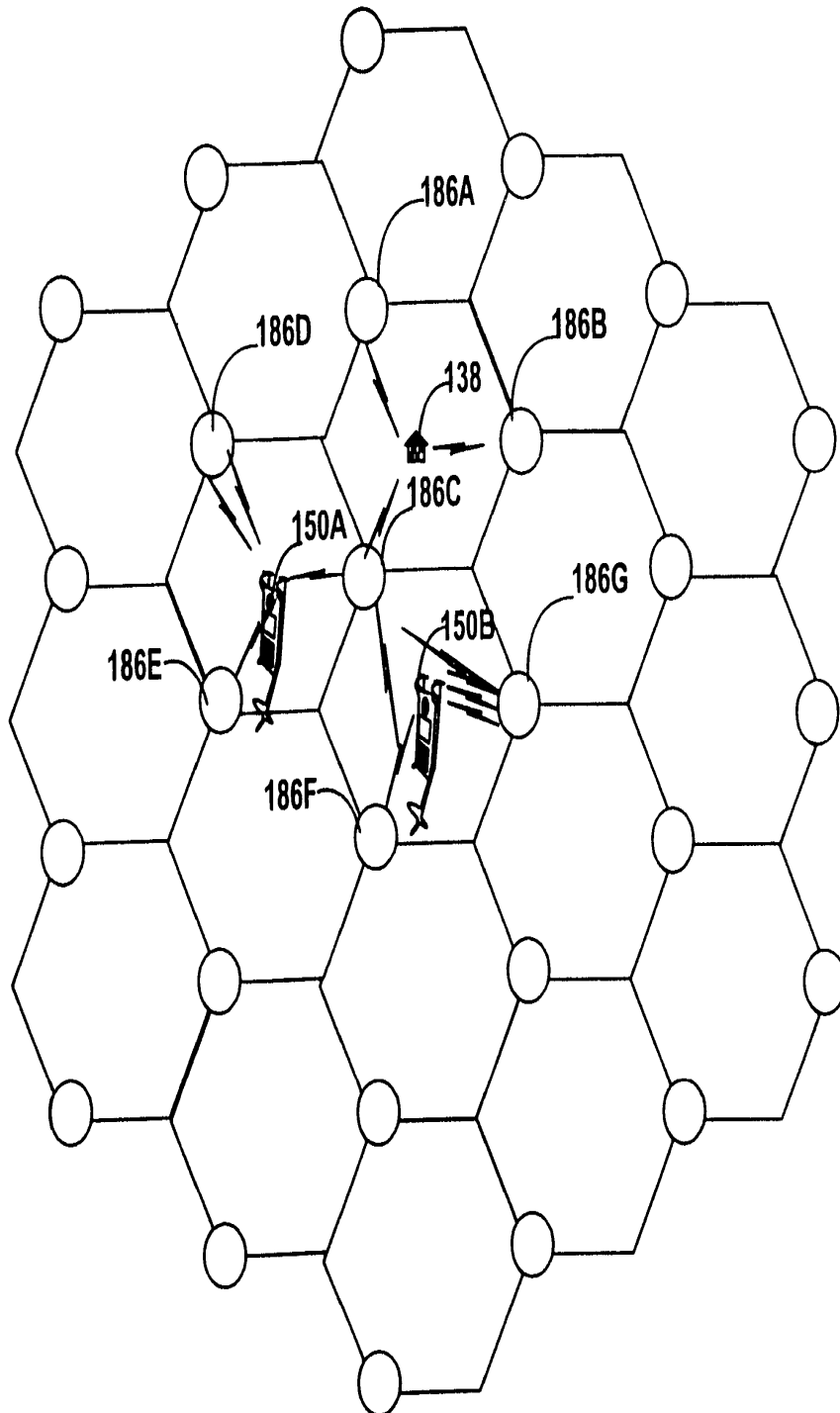


FIG.1C



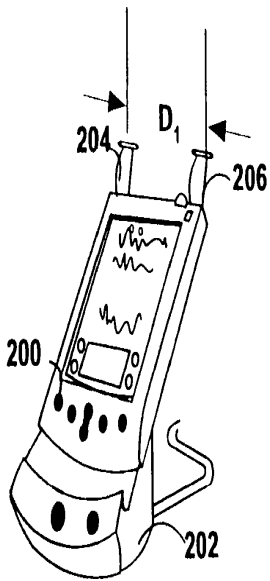


FIG. 2D

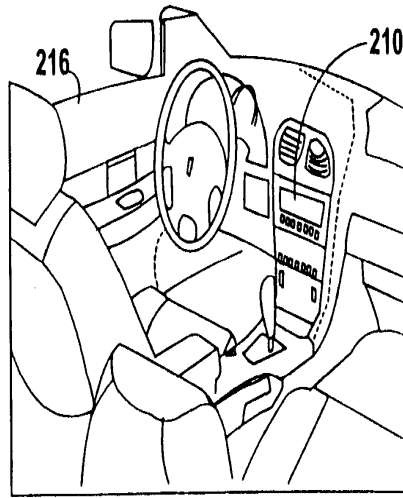


FIG. 2E

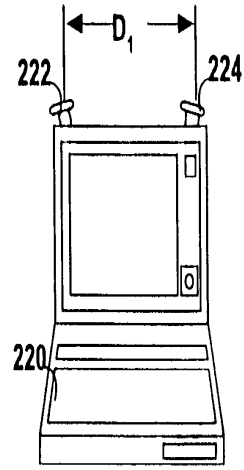


FIG. 2F

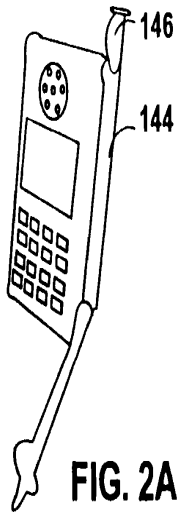


FIG. 2A

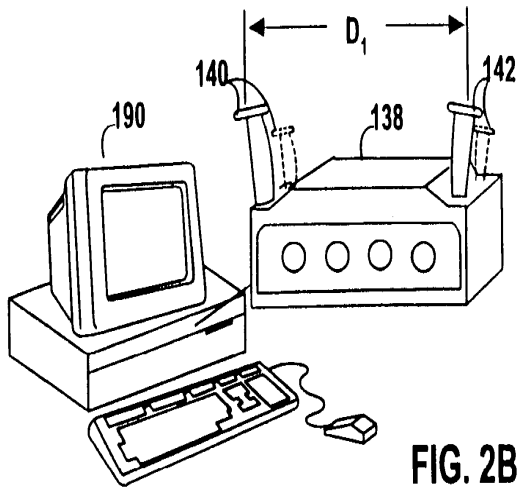


FIG. 2B

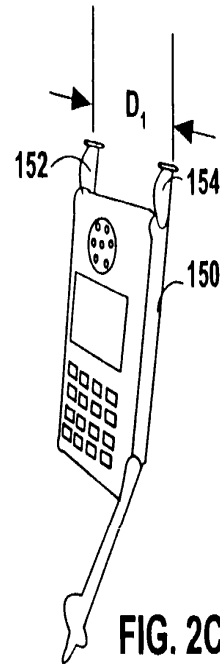


FIG. 2C

5/36

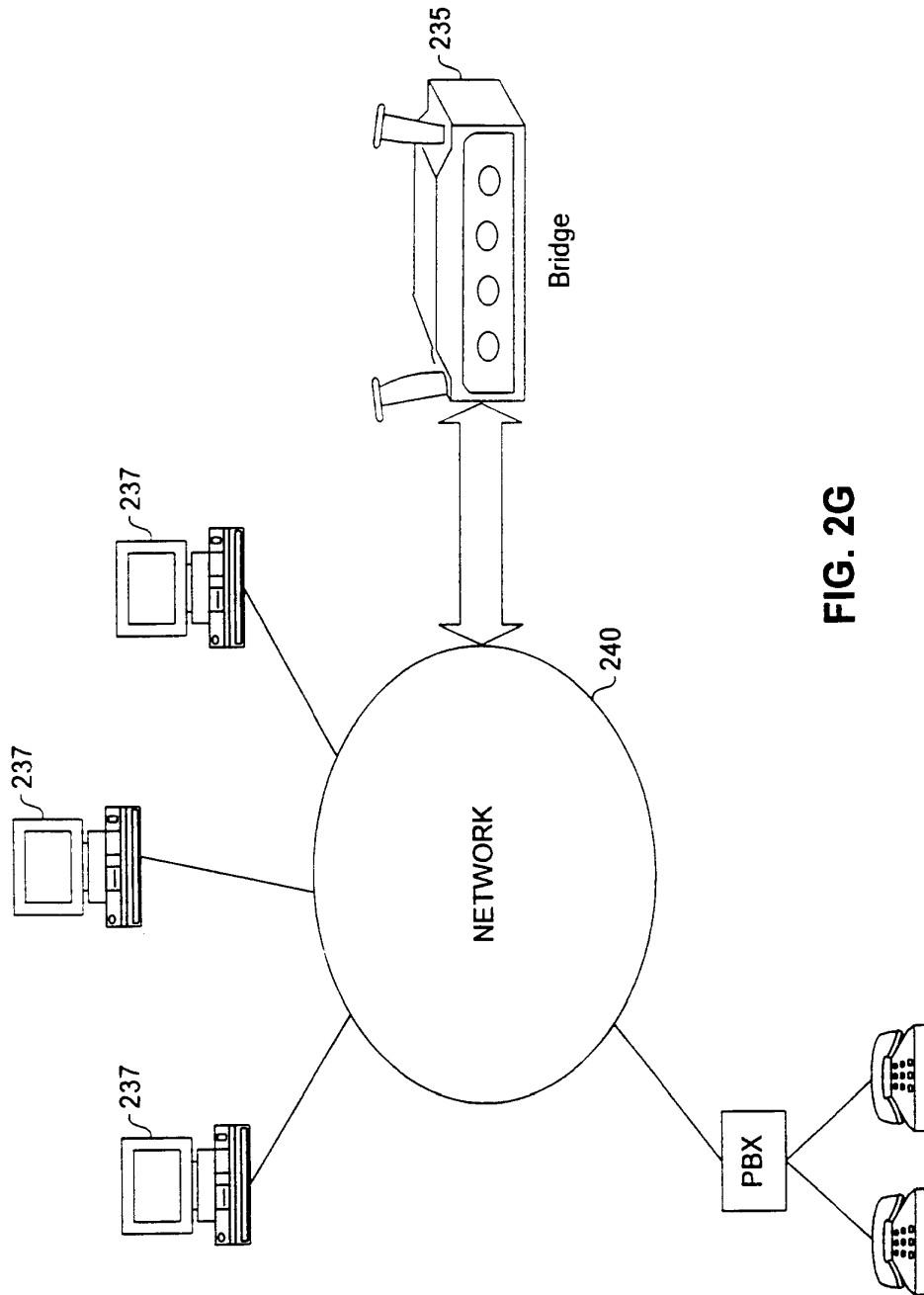


FIG. 2G

SUBSTITUTE SHEET (RULE 26)

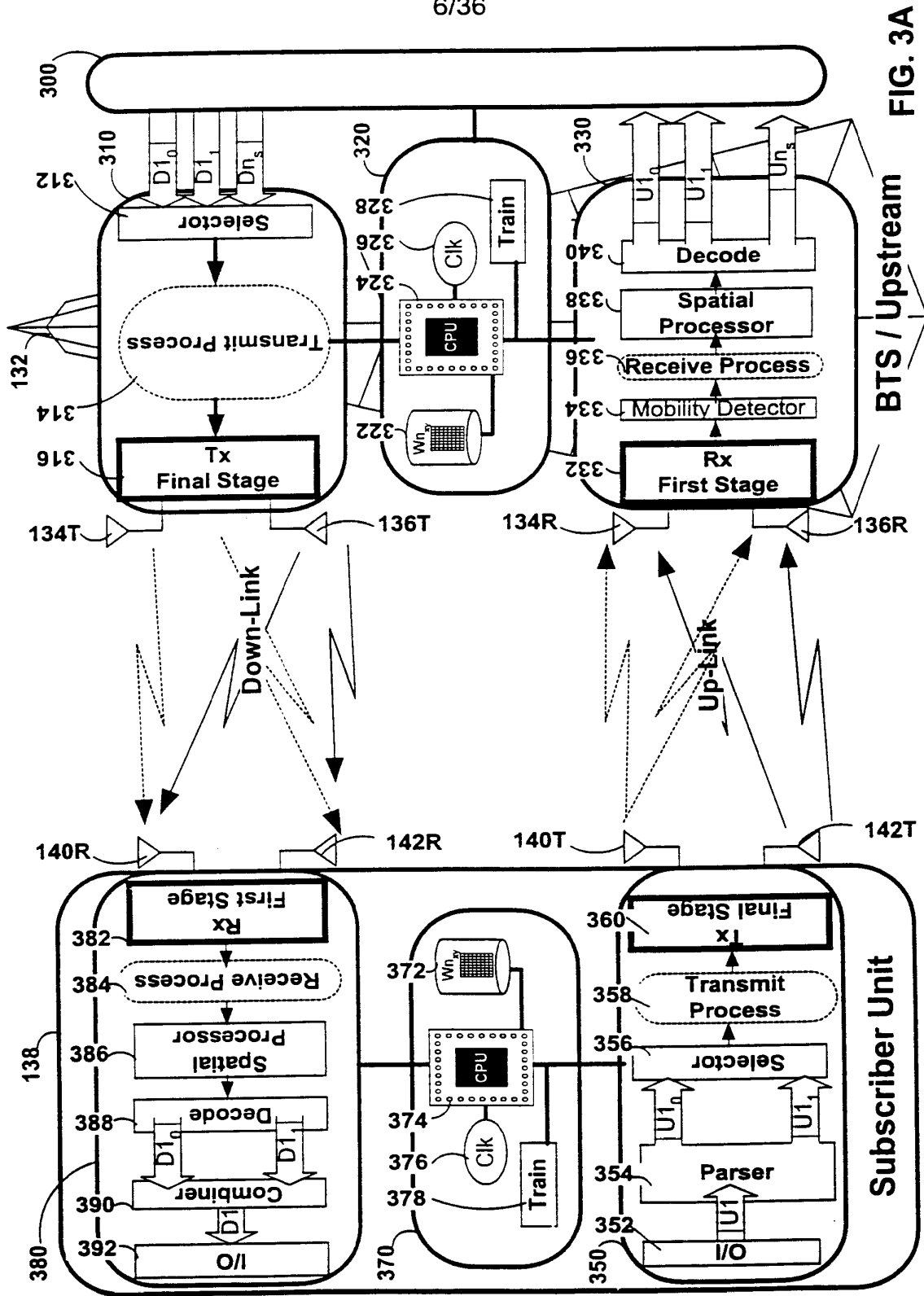
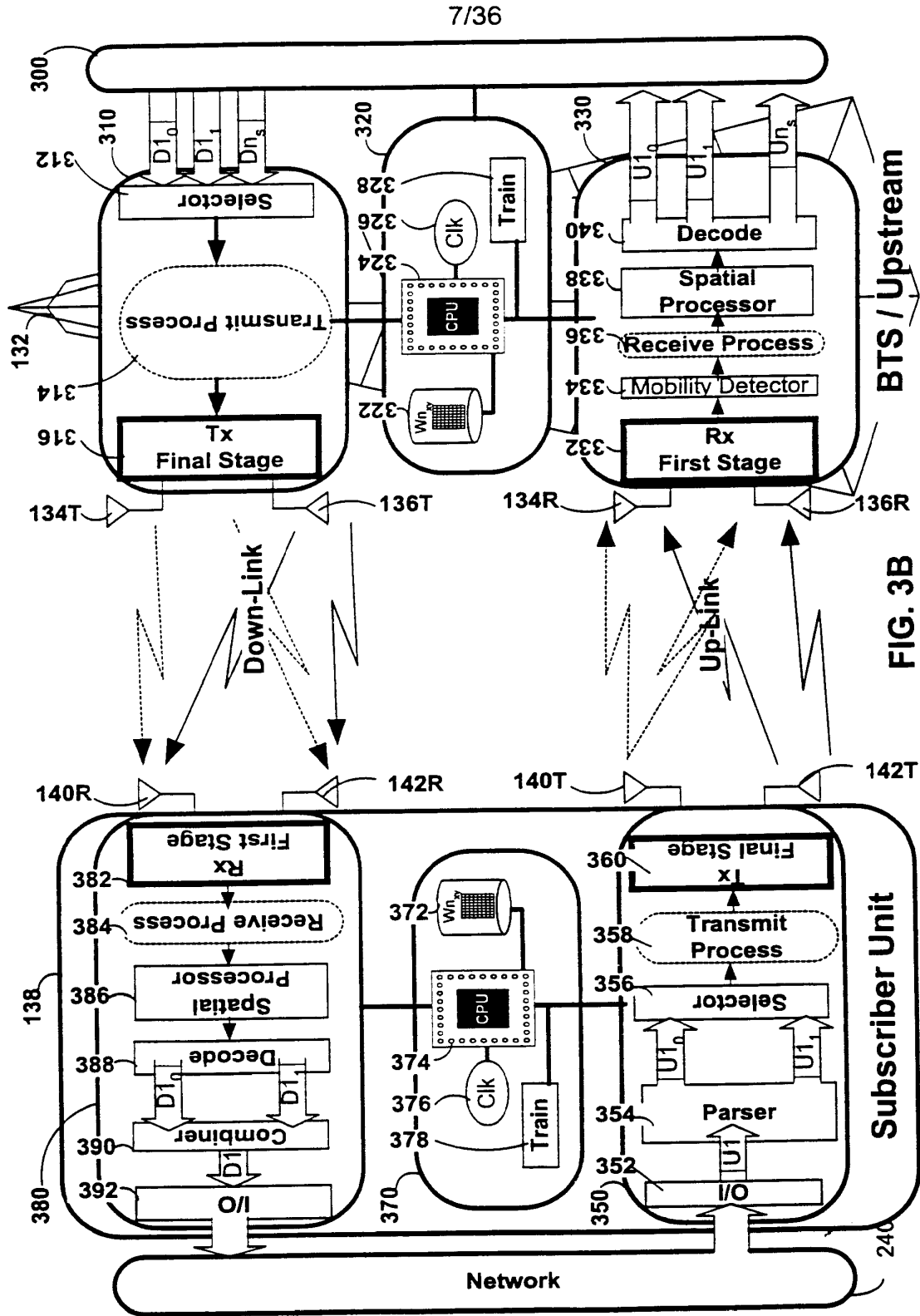


FIG. 3A



SUBSTITUTE SHEET (RULE 26)

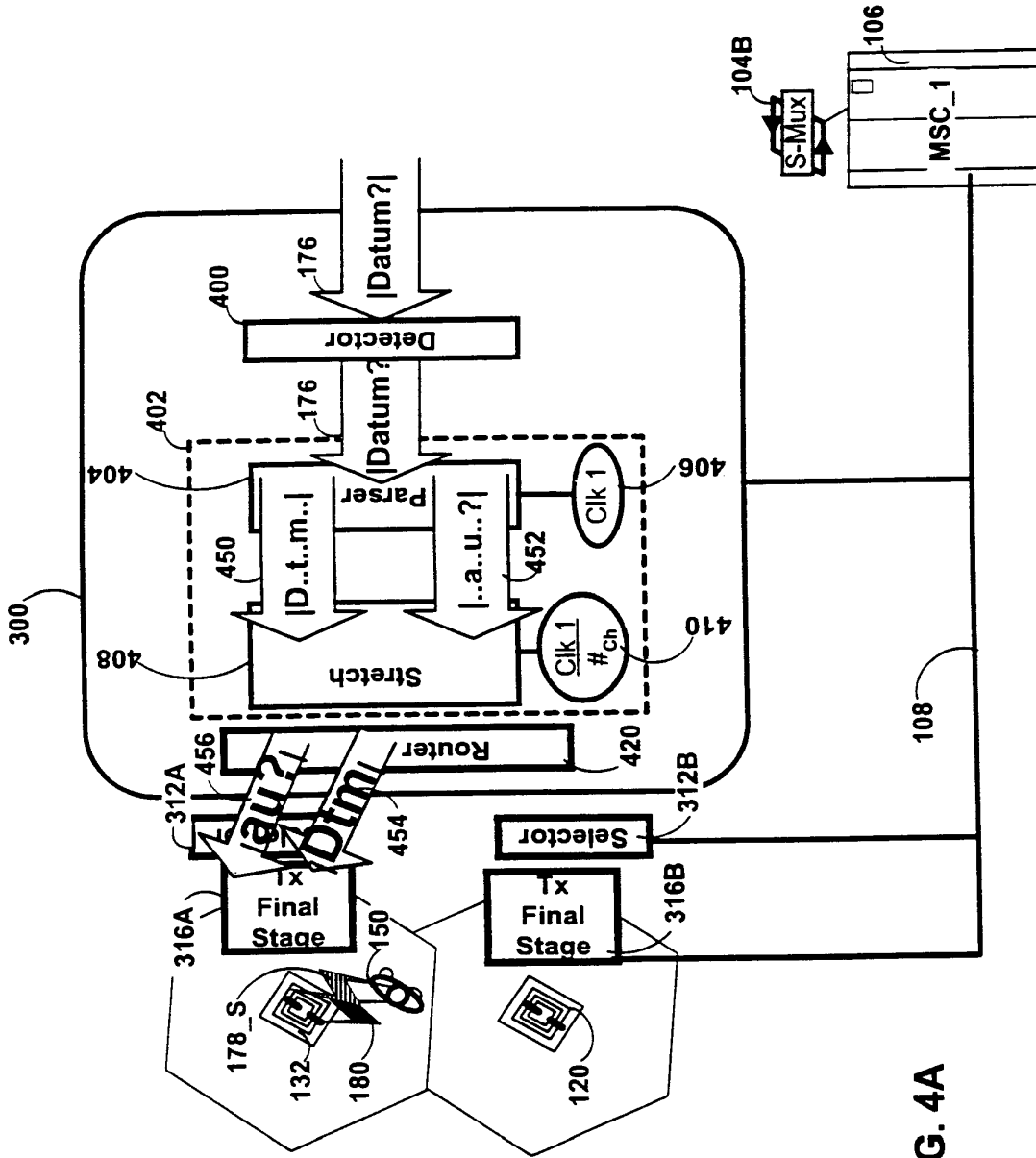


FIG. 4A

SUBSTITUTE SHEET (RULE 26)

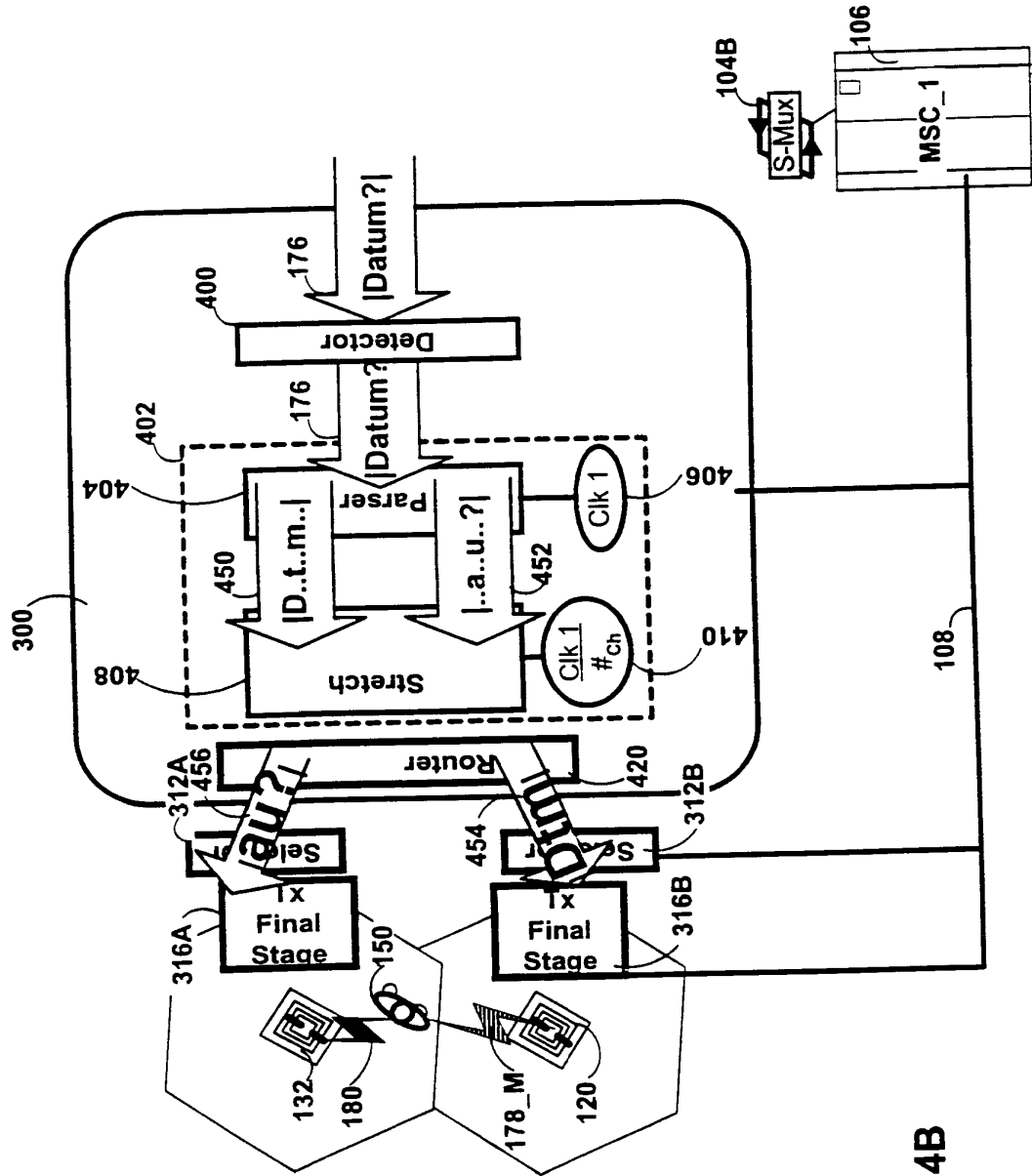


FIG. 4B

SUBSTITUTE SHEET (RULE 26)



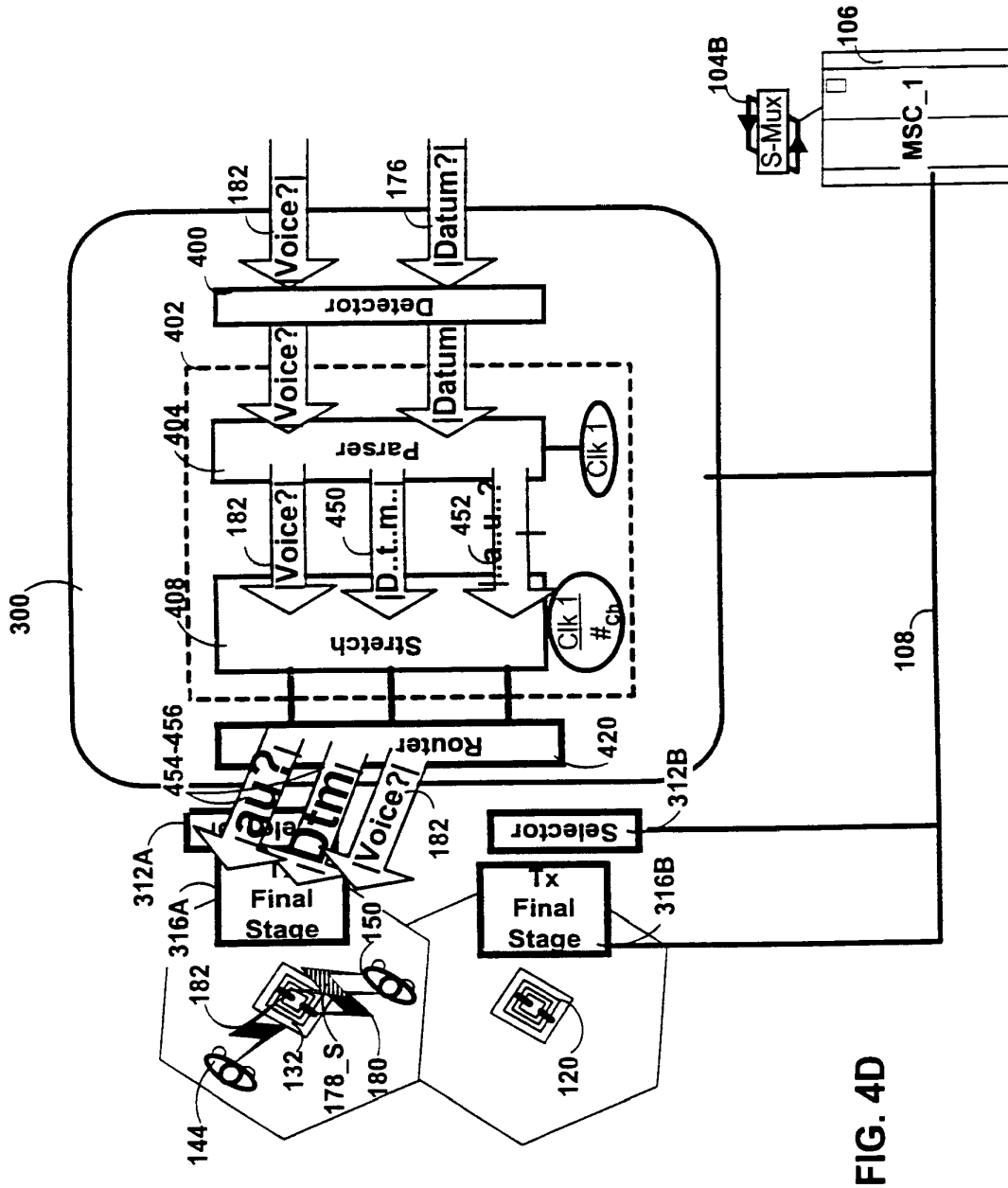


FIG. 4D

SUBSTITUTE SHEET (RULE 26)



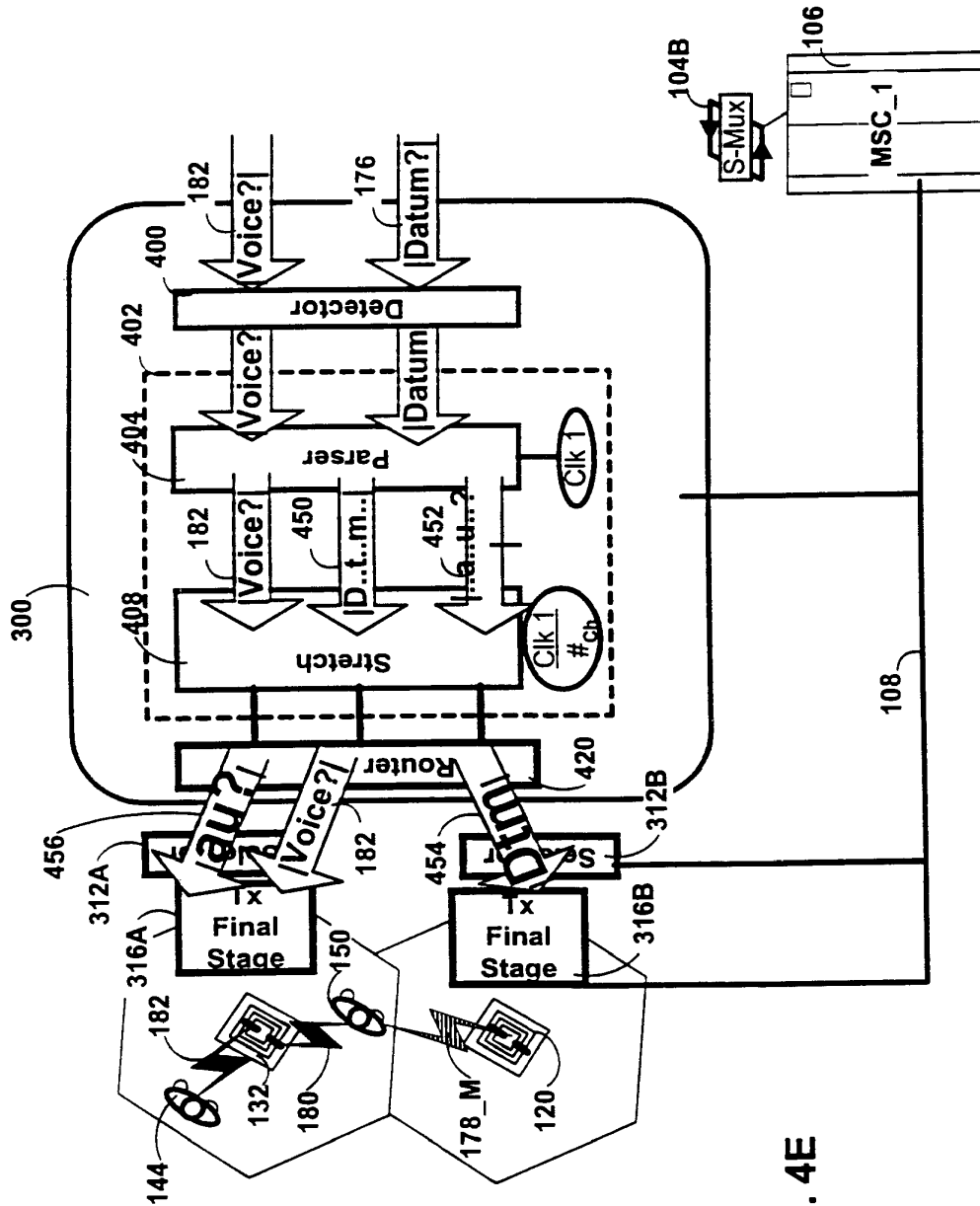


FIG. 4E

SUBSTITUTE SHEET (RULE 26)

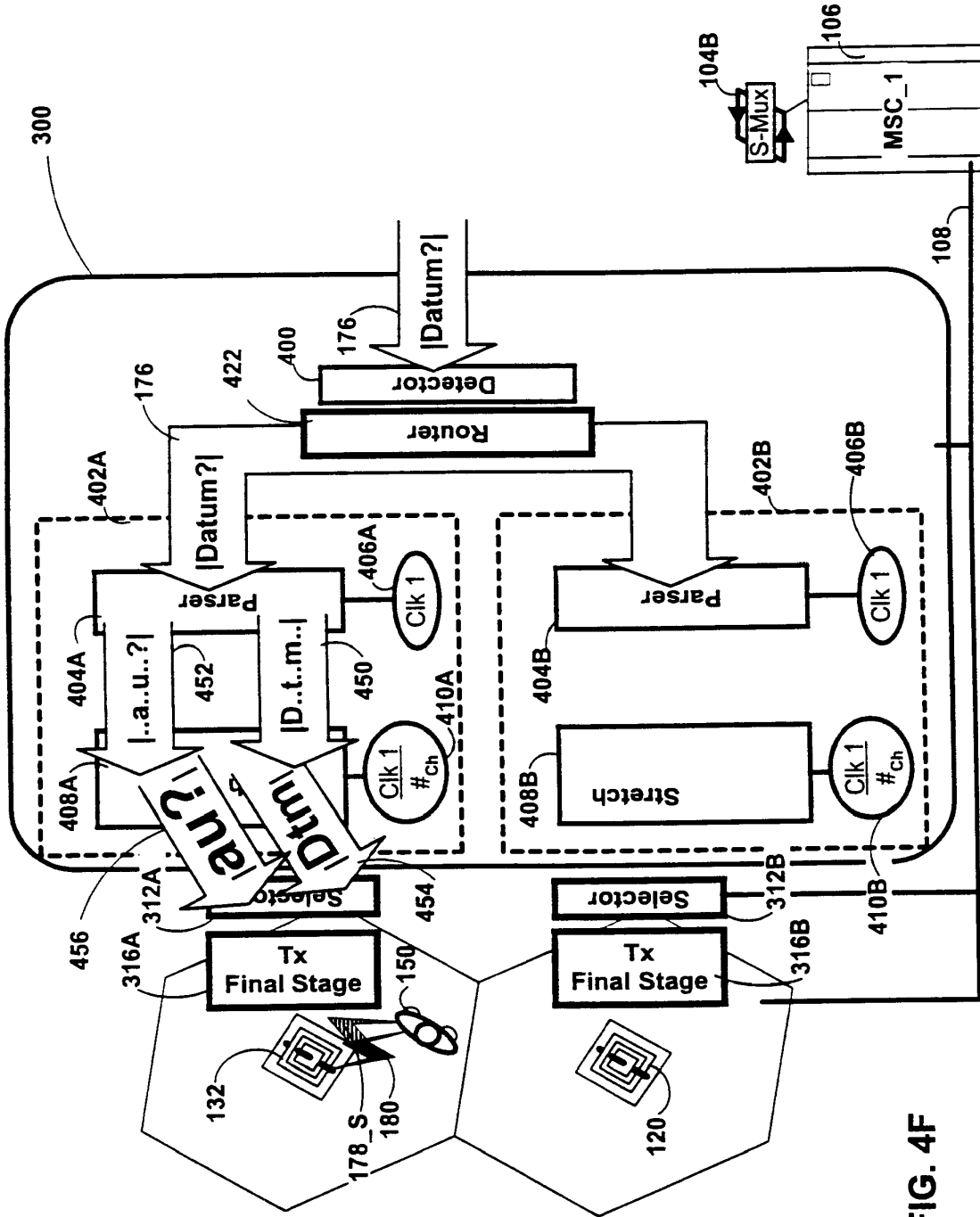


FIG. 4F

SUBSTITUTE SHEET (RULE 26)

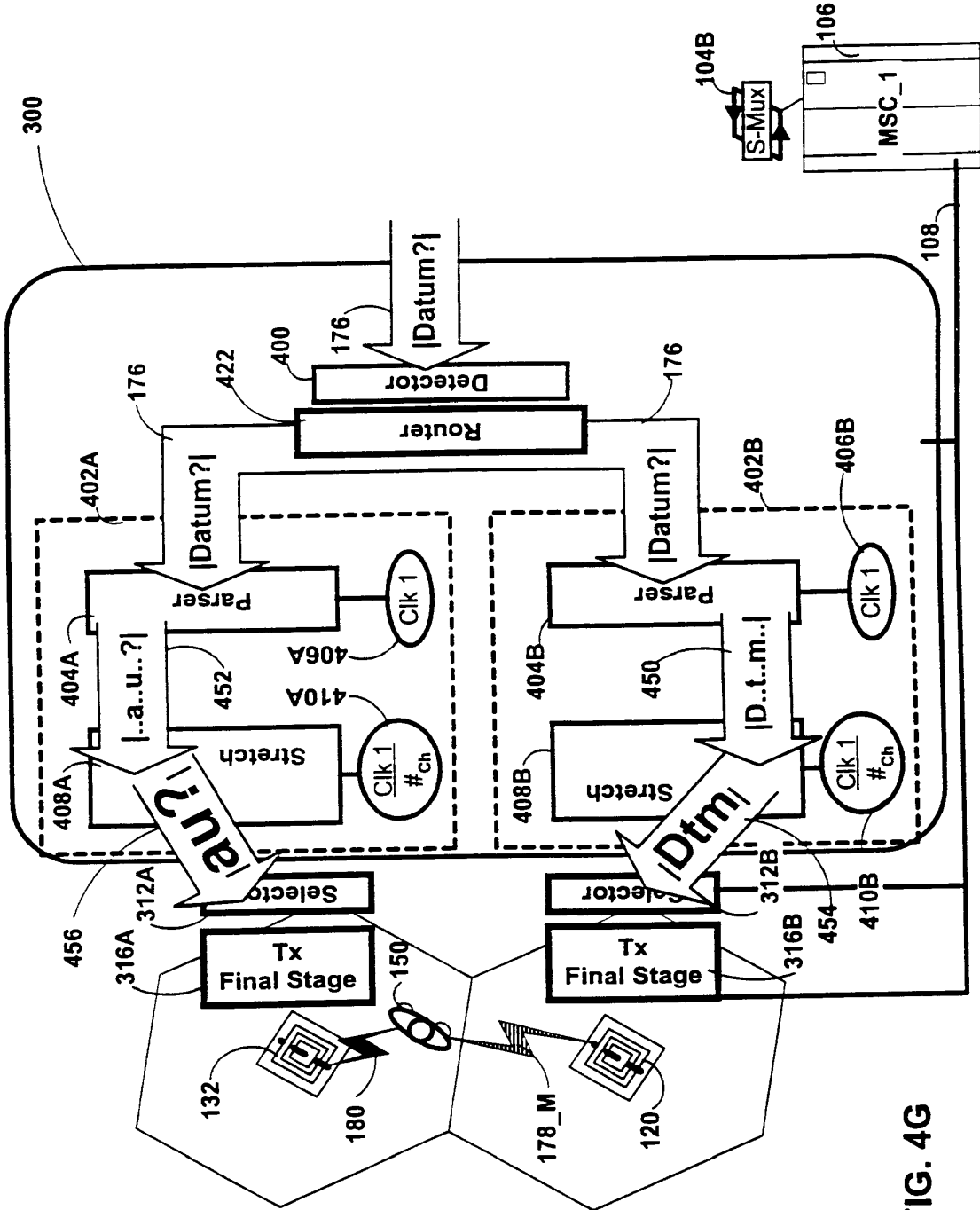


FIG. 4G

SUBSTITUTE SHEET (RULE 26)

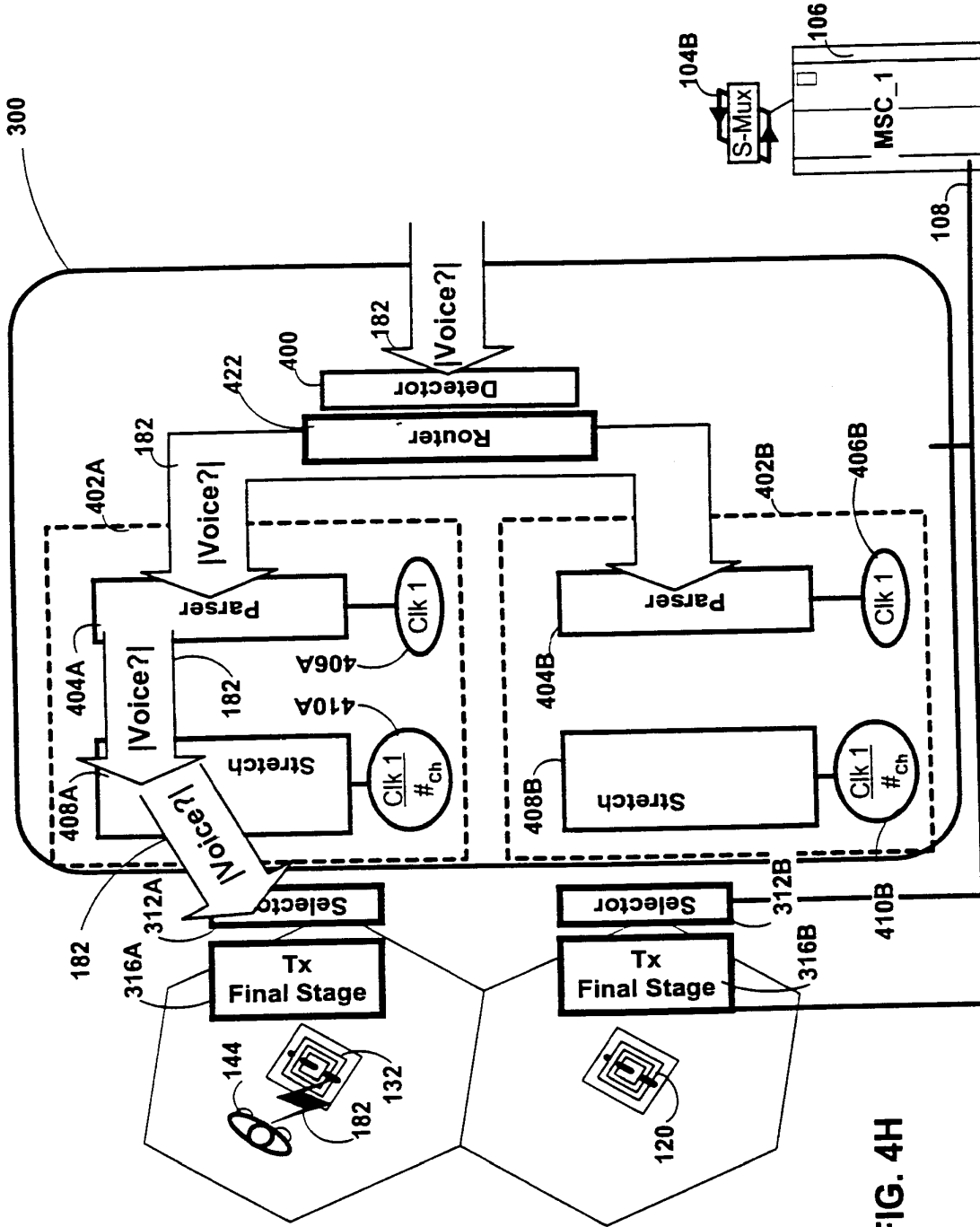


FIG. 4H

SUBSTITUTE SHEET (RULE 26)





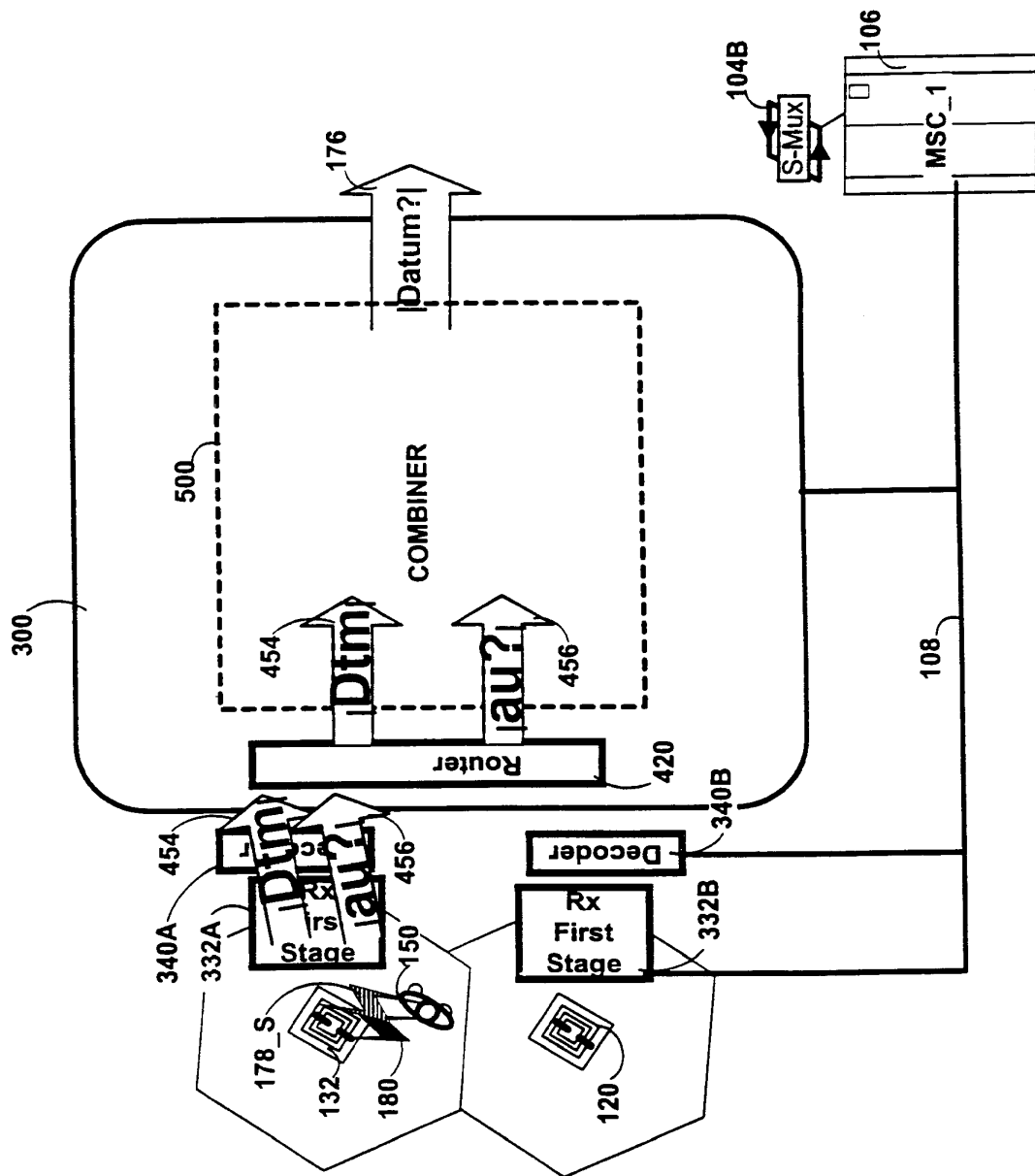


FIG. 5A

SUBSTITUTE SHEET (RULE 26)

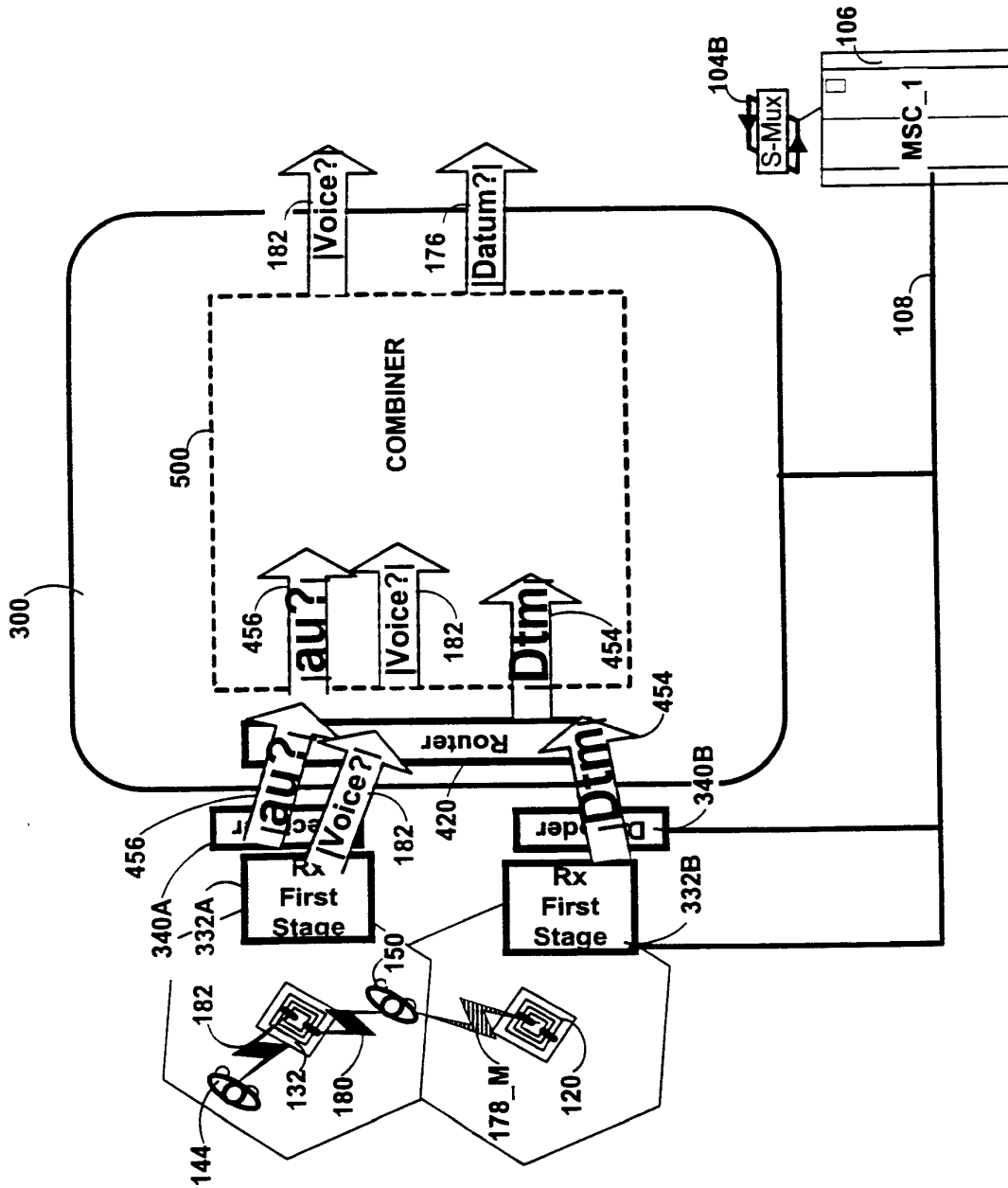
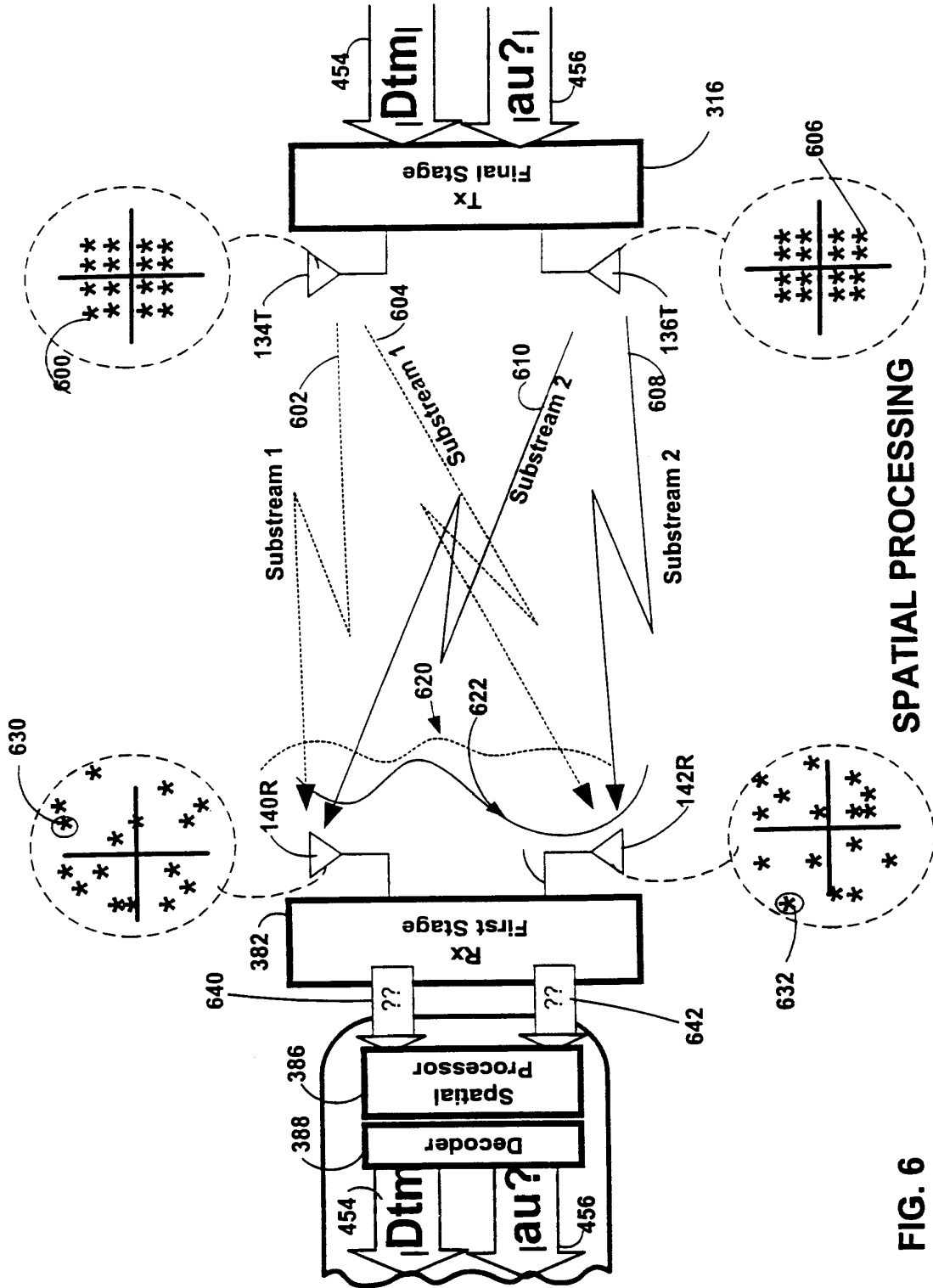


FIG. 5B

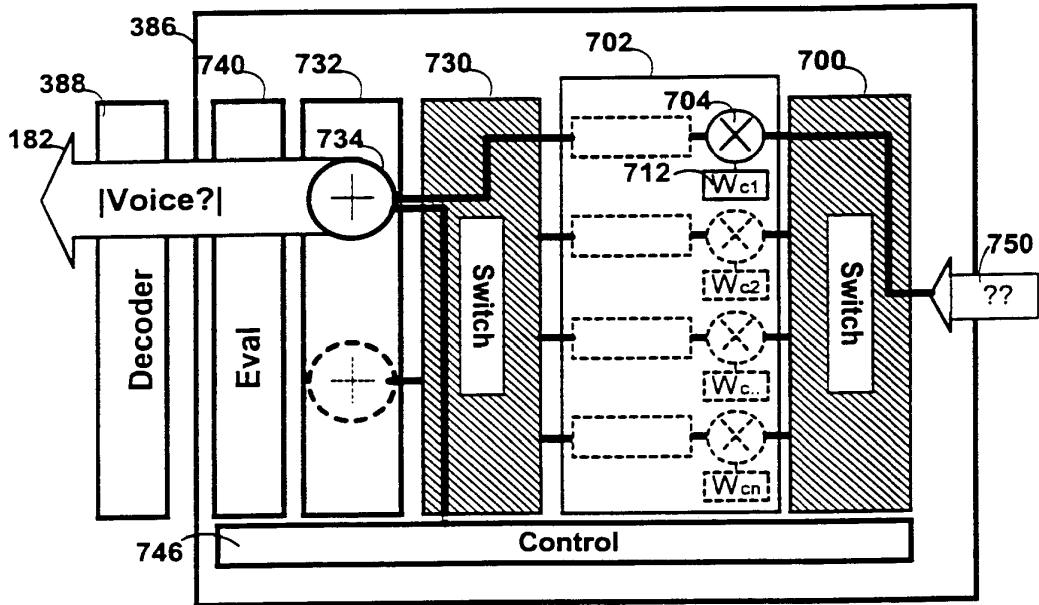
SUBSTITUTE SHEET (RULE 26)



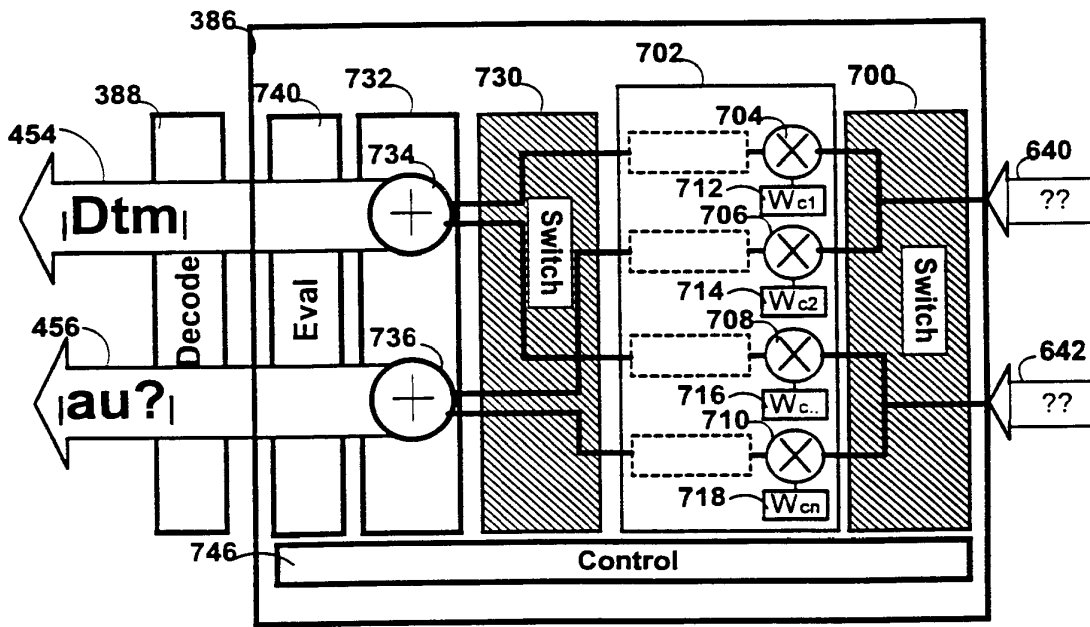
20/36



SUBSTITUTE SHEET (RULE 26)



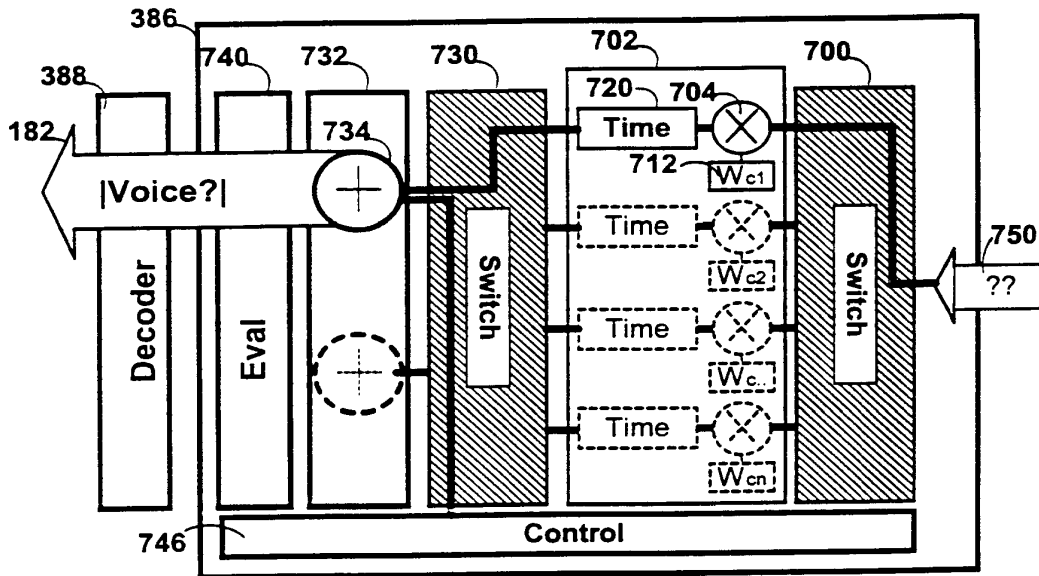
Spatial Processor FIG. 7A



Spatial Processor

FIG. 7B

22/36



Space-Time Processor FIG. 7C

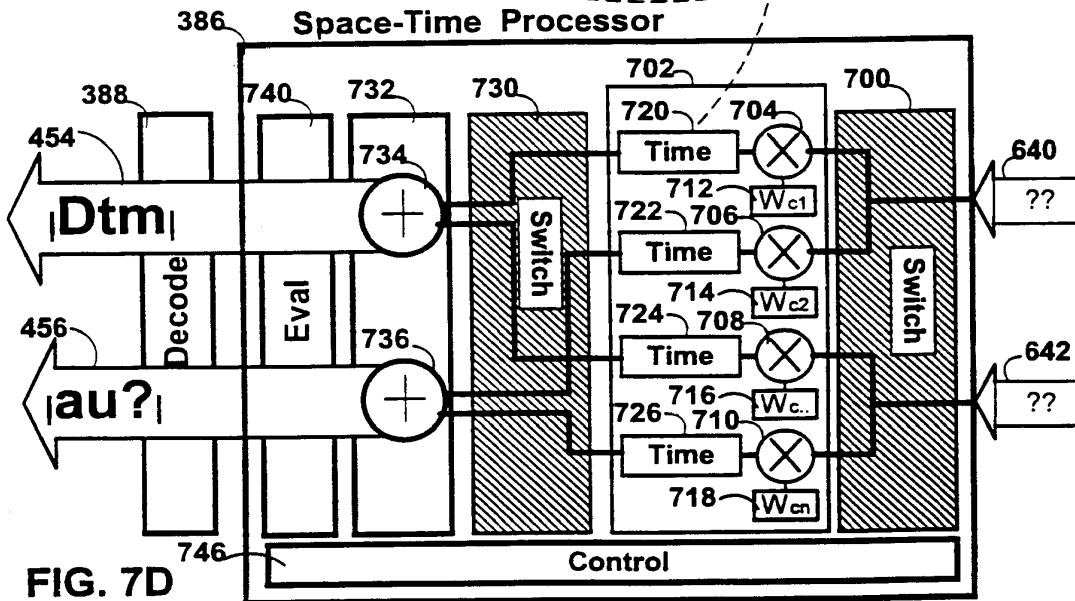
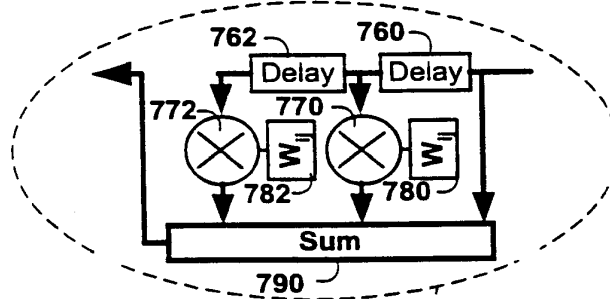


FIG. 7D

SUBSTITUTE SHEET (RULE 26)

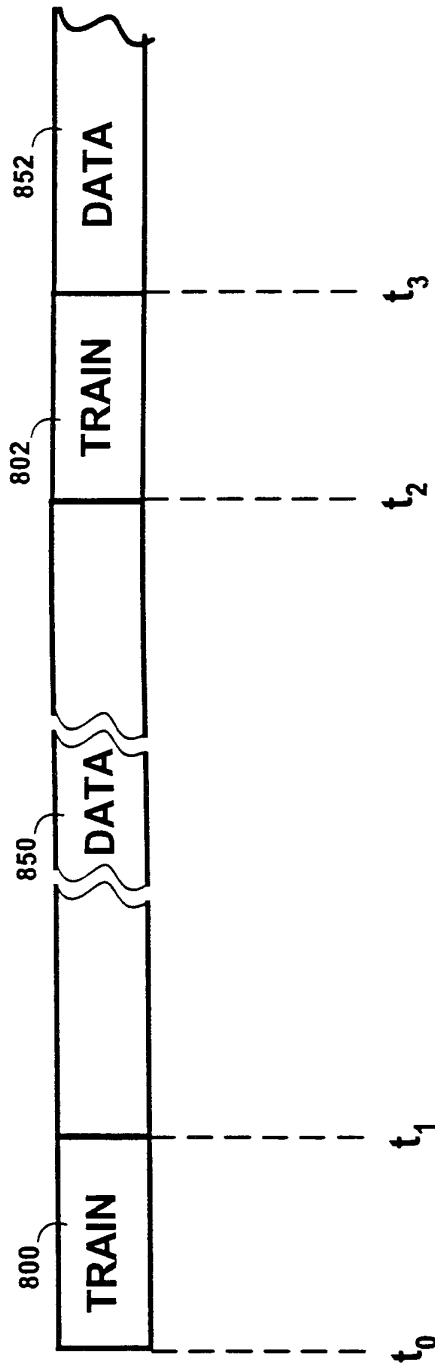


FIG. 8

SUBSTITUTE SHEET (RULE 26)



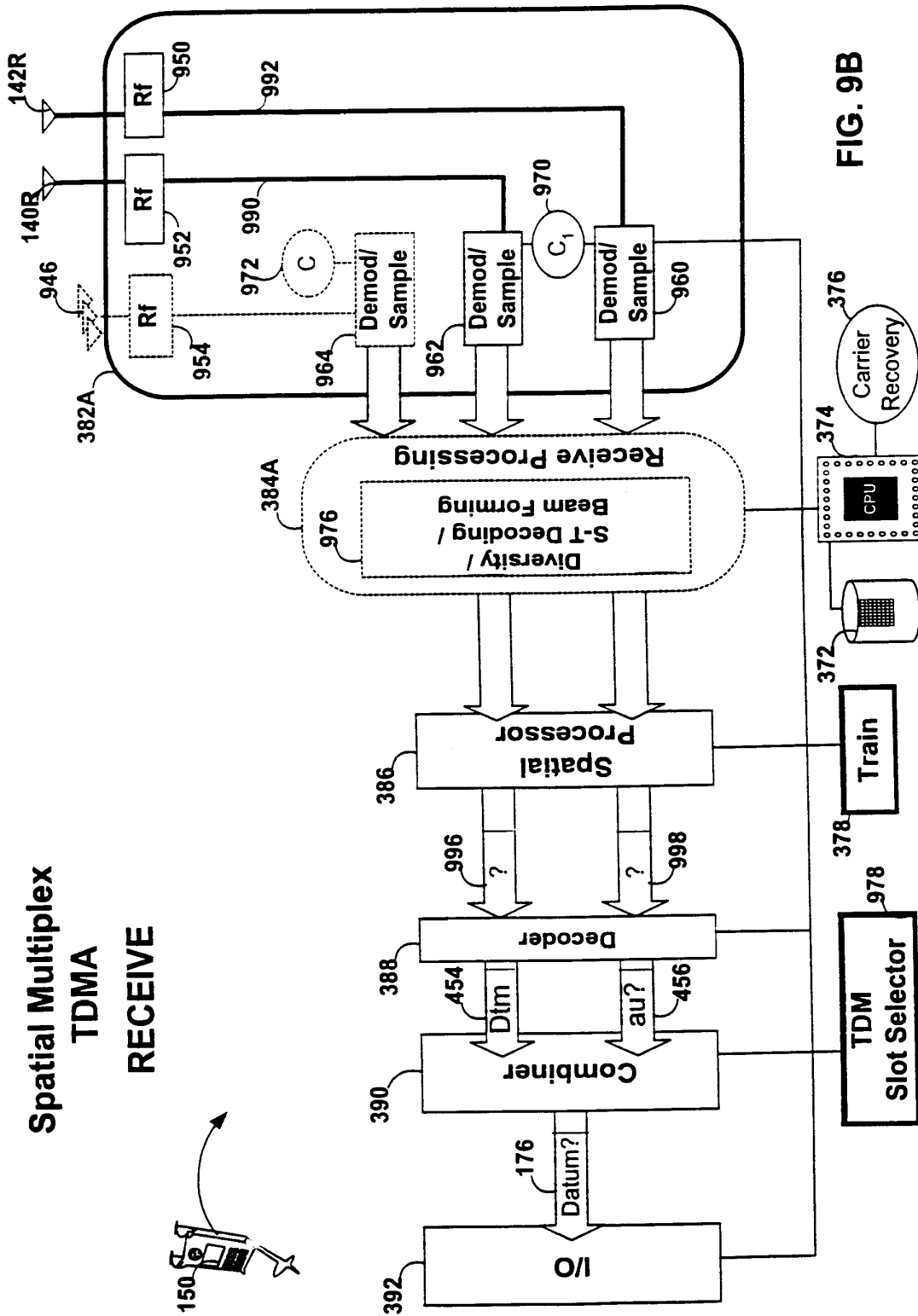


FIG. 9B

SUBSTITUTE SHEET (RULE 26)

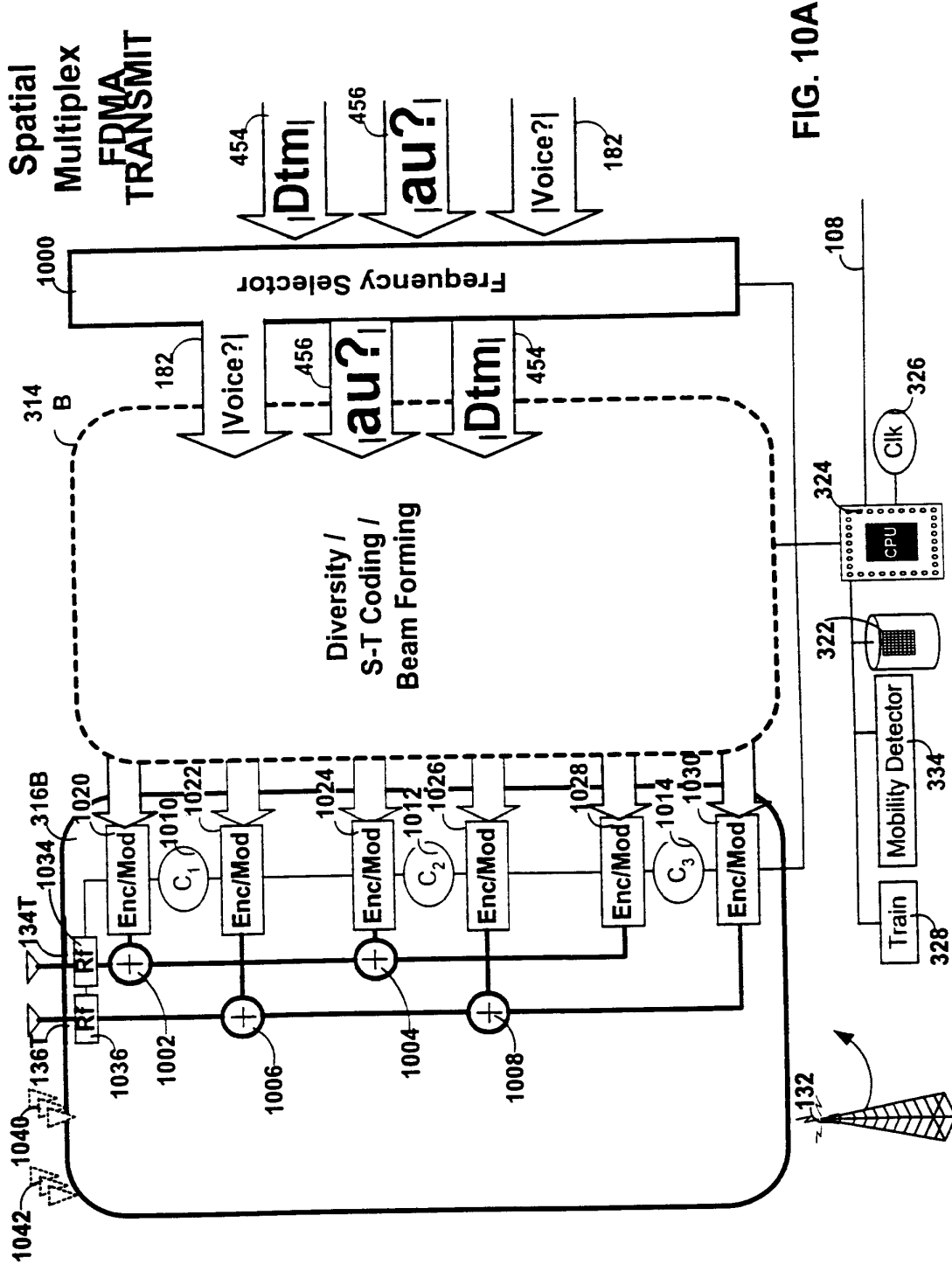


FIG. 10A

SUBSTITUTE SHEET (RULE 26)

27/36

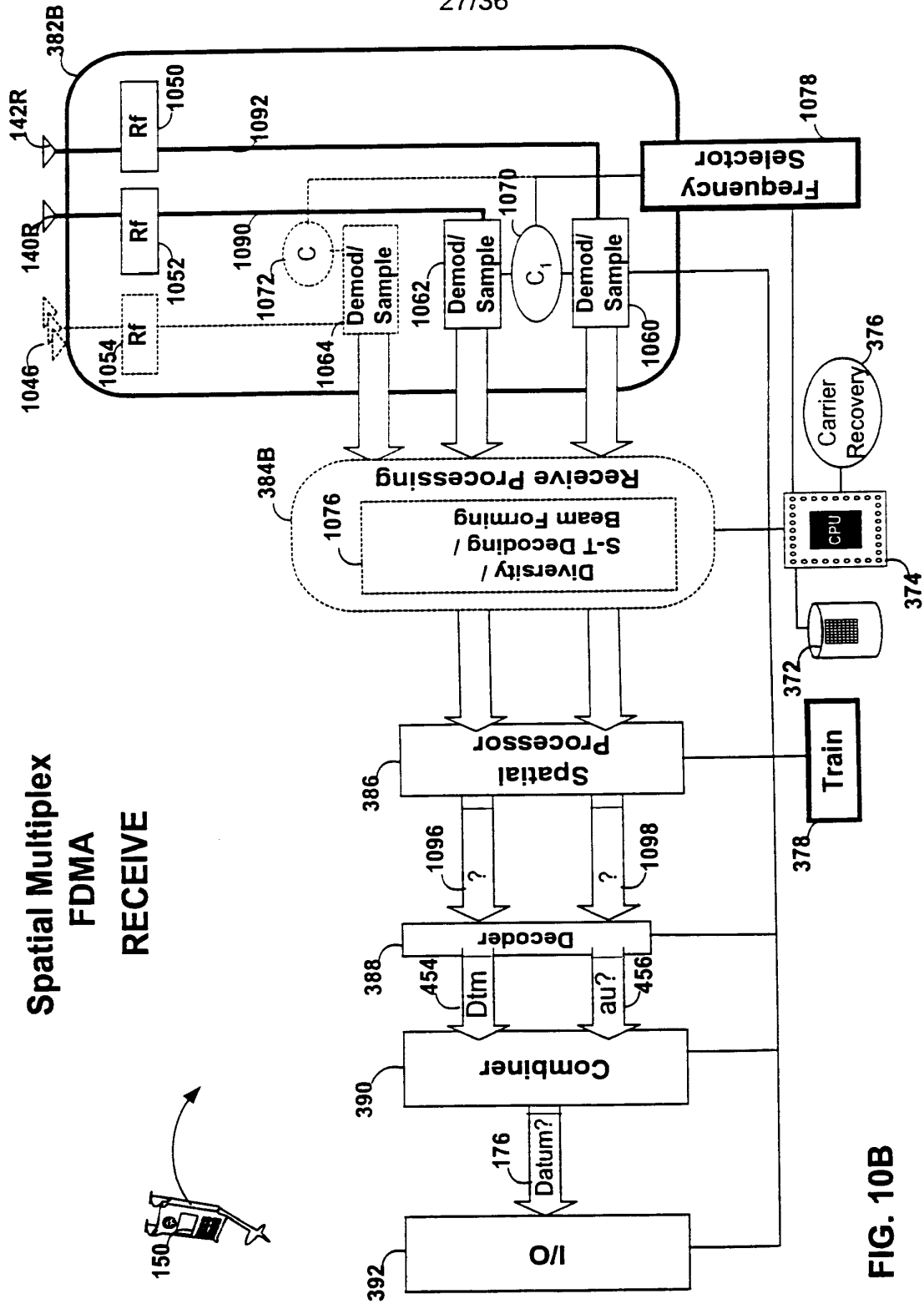
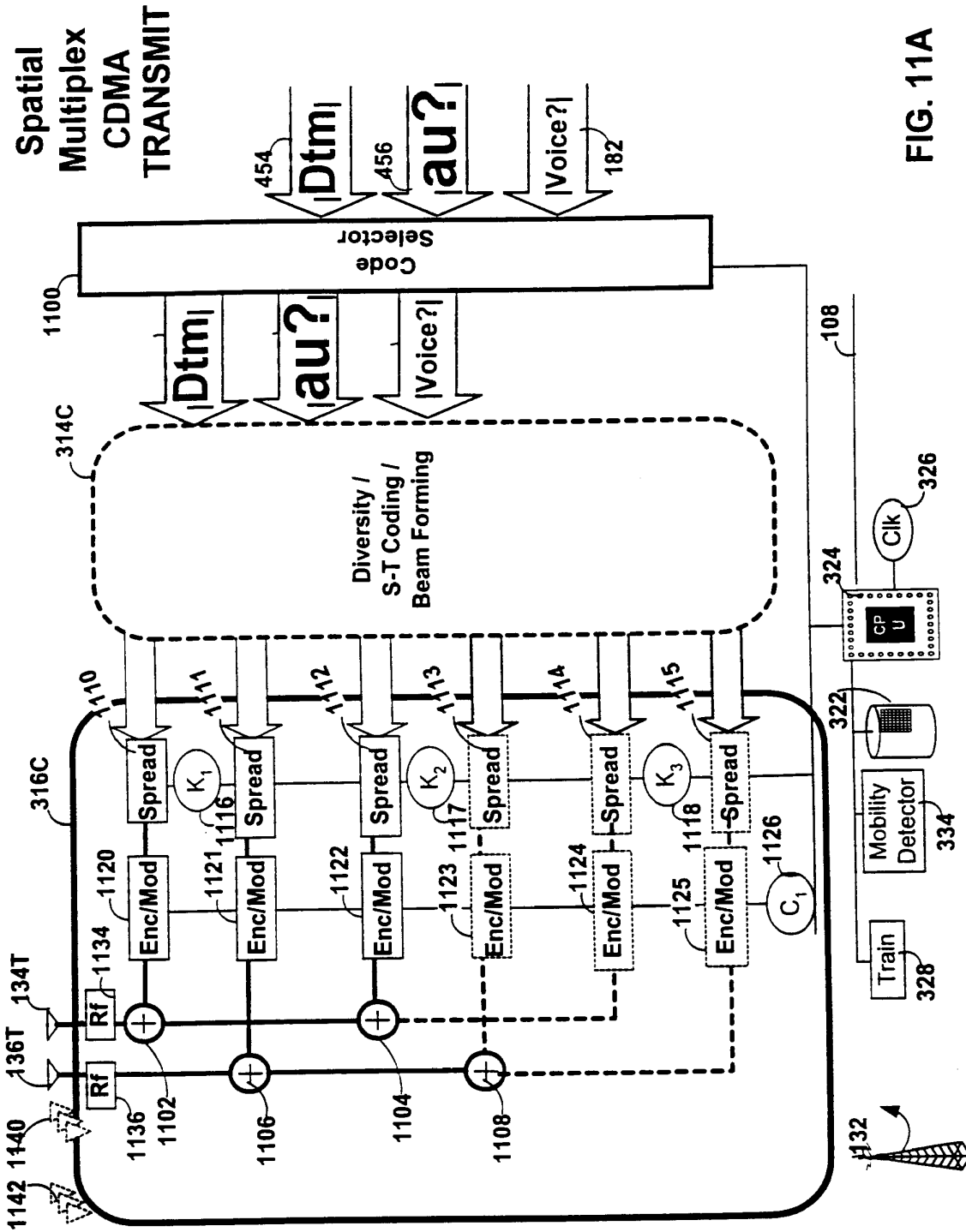


FIG. 10B

SUBSTITUTE SHEET (RULE 26)





Spatial  
Multiplex  
CDMA  
TRANSMIT

FIG. 11A

SUBSTITUTE SHEET (RULE 26)

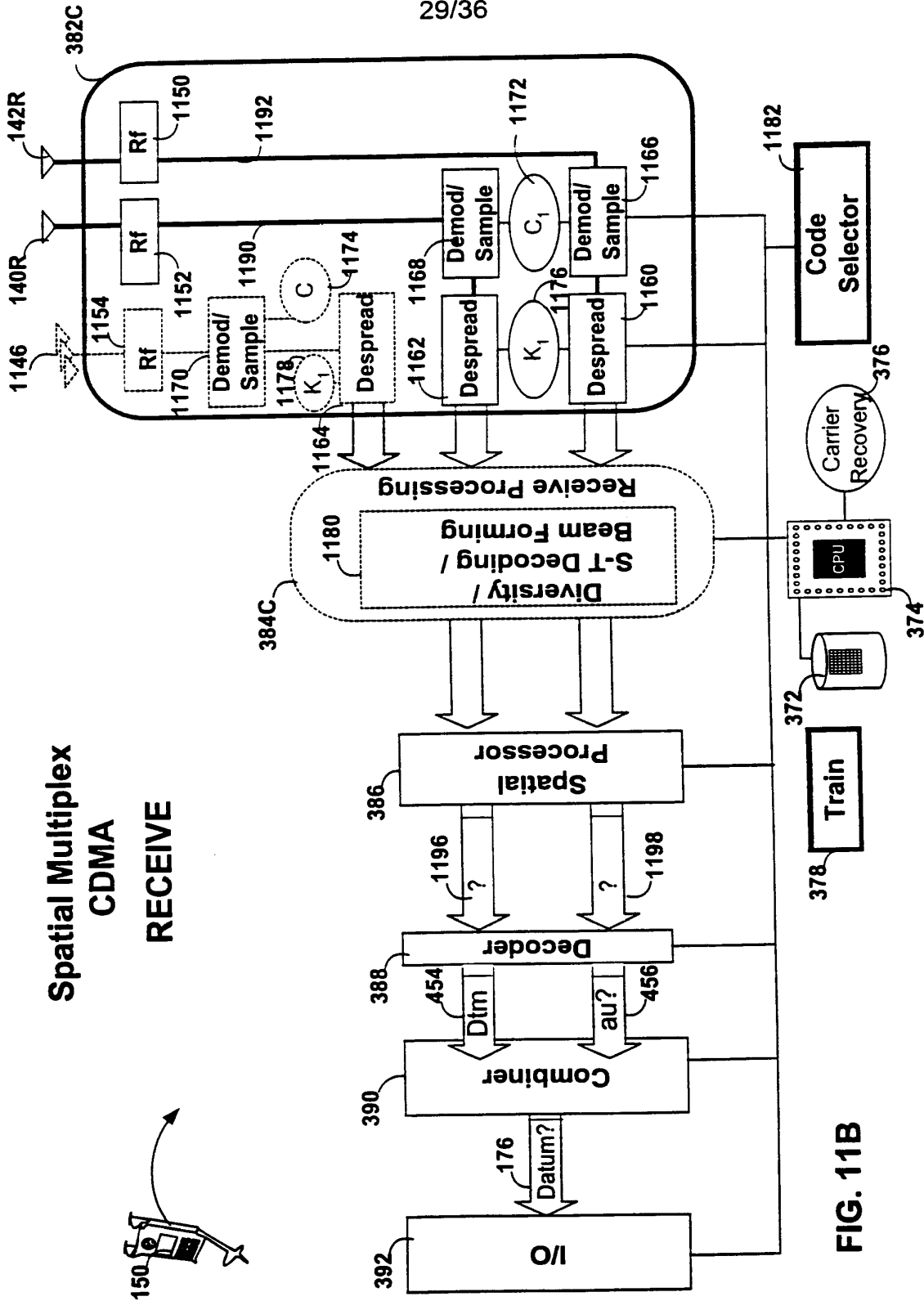


FIG. 11B

SUBSTITUTE SHEET (RULE 26)

Spatial Multiplex SDMA TRANSMIT

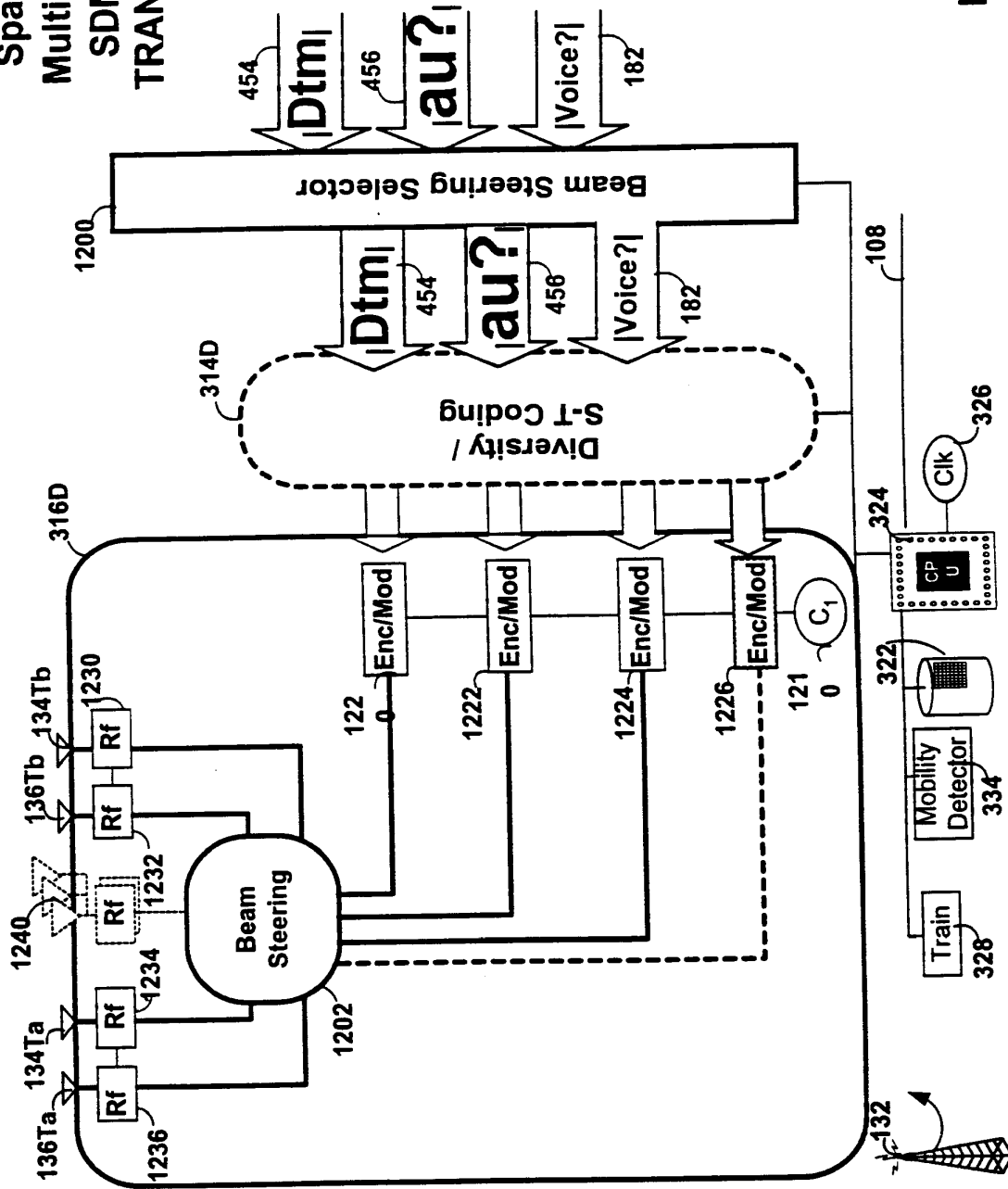
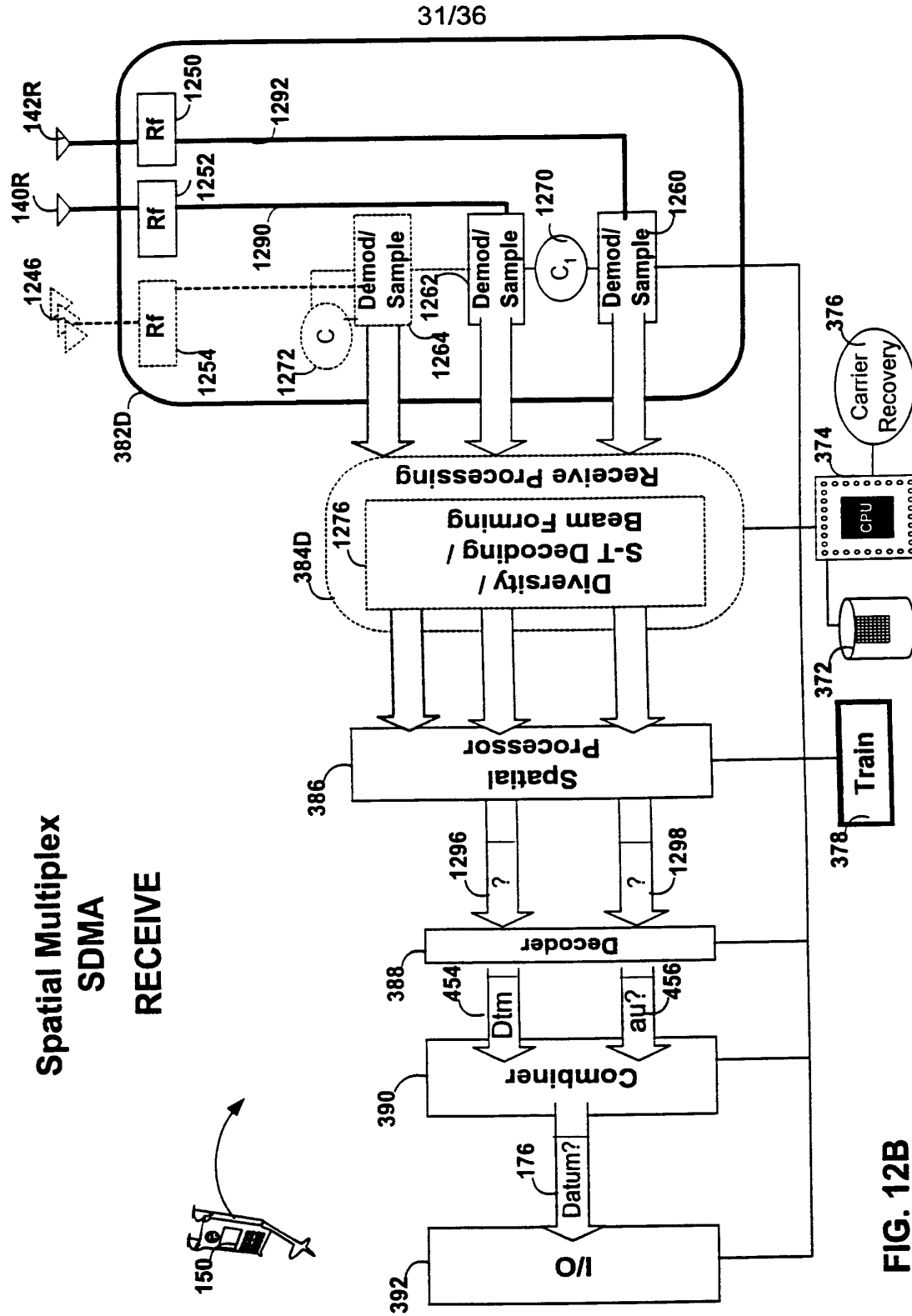


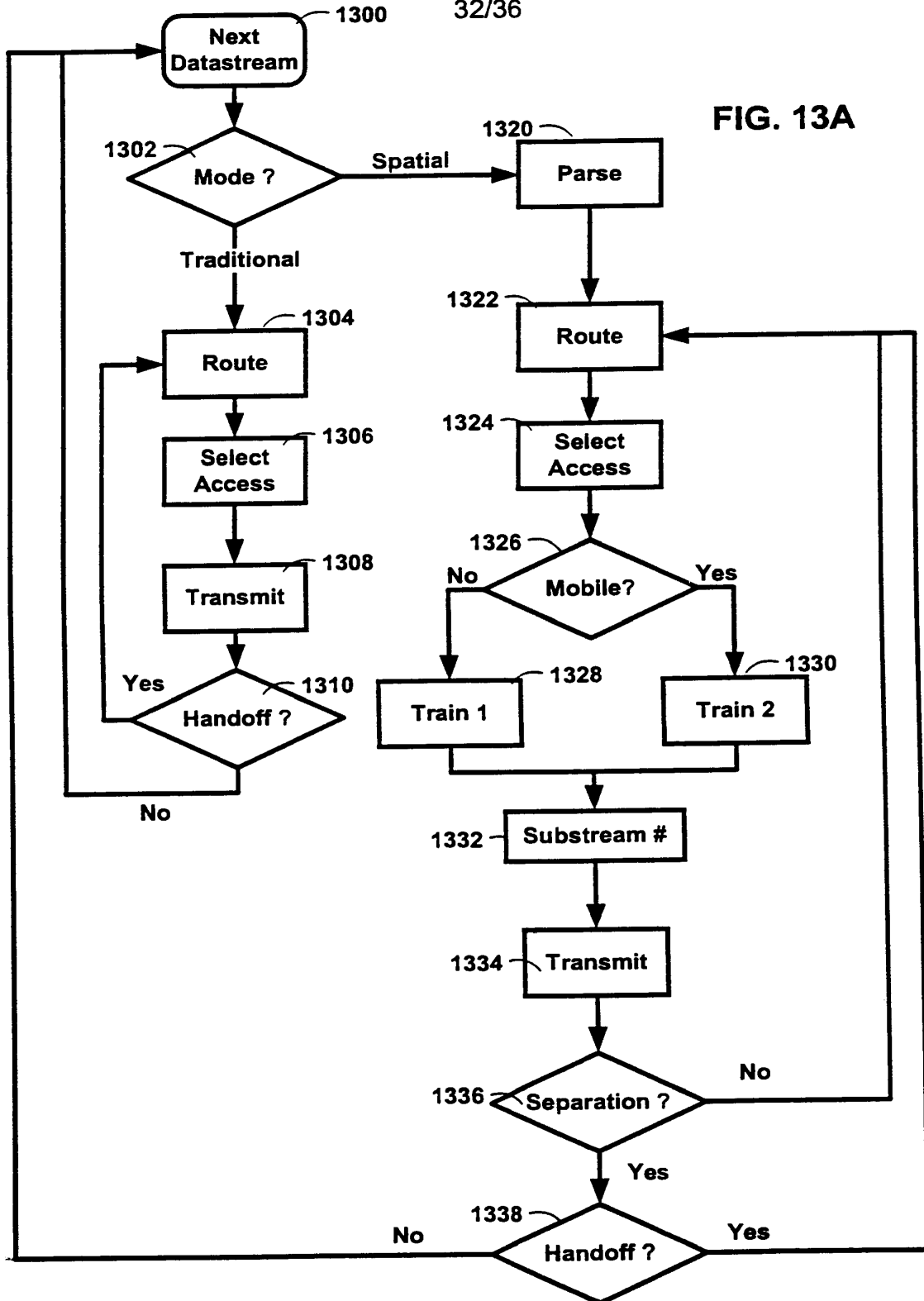
FIG. 12A



SUBSTITUTE SHEET (RULE 26)

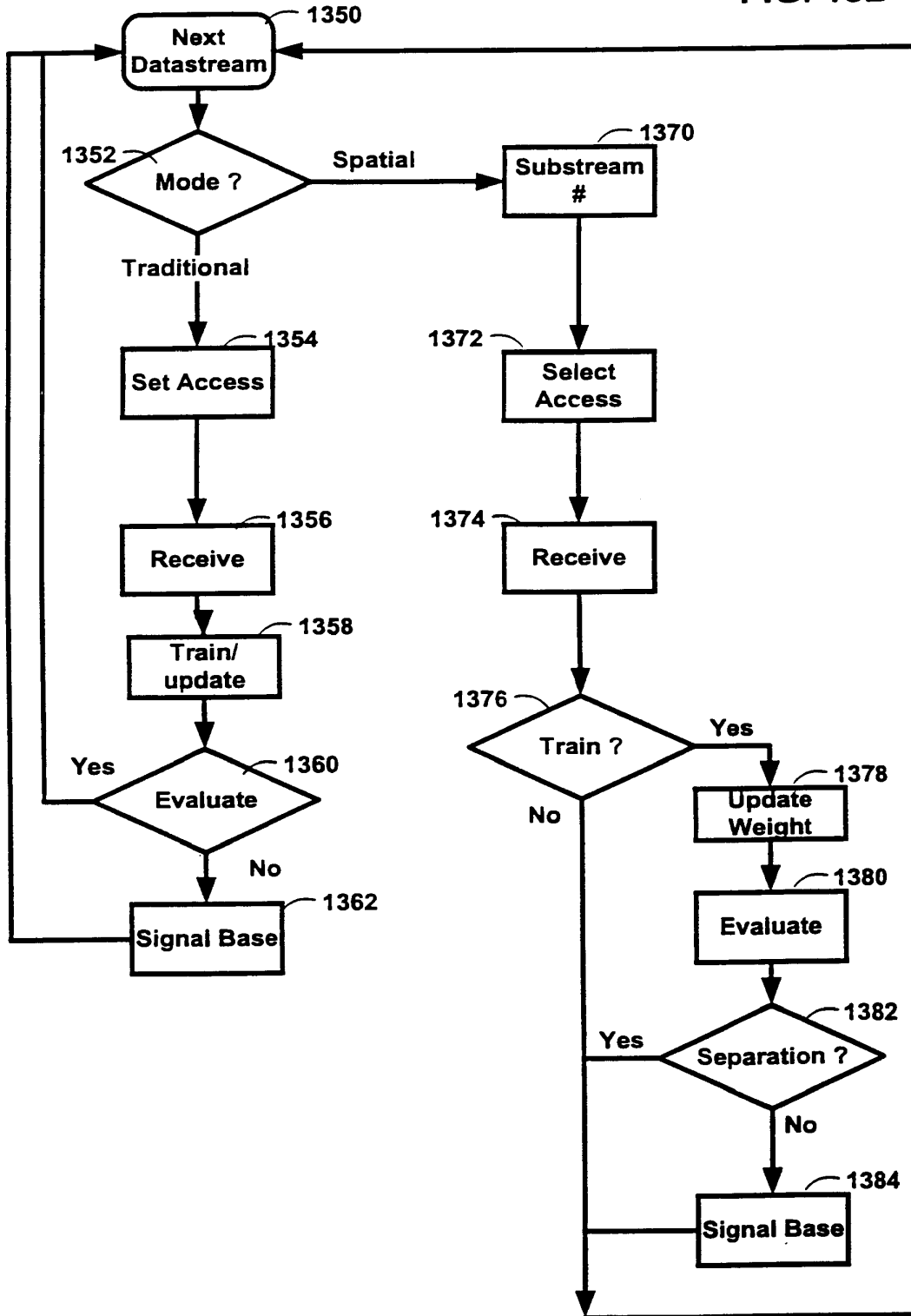
32/36

FIG. 13A



SUBSTITUTE SHEET (RULE 26)

FIG. 13B



SUBSTITUTE SHEET (RULE 26)

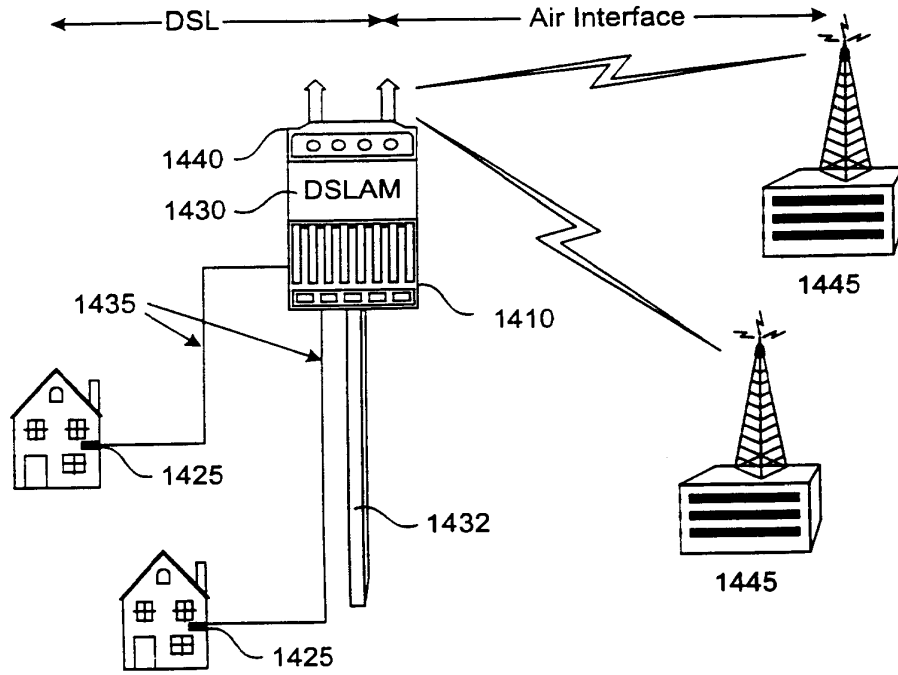


FIG. 14

**SUBSTITUTE SHEET (RULE 26)**

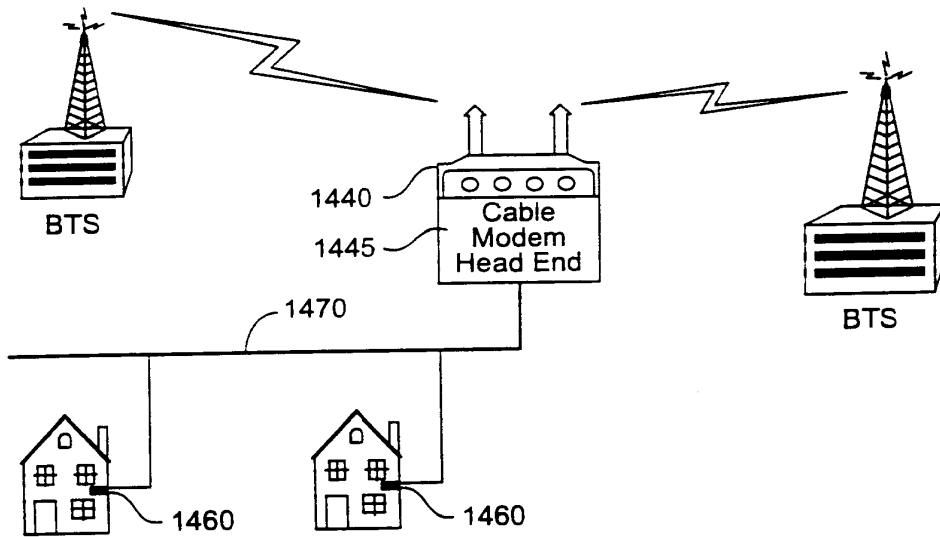


FIG. 15

**SUBSTITUTE SHEET (RULE 26)**



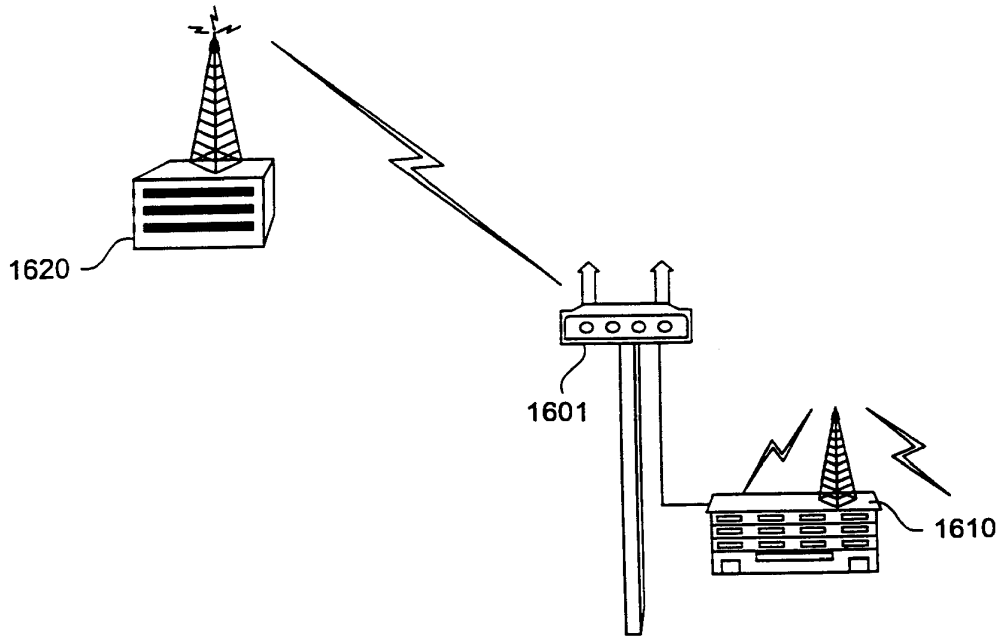


FIG. 16

**SUBSTITUTE SHEET (RULE 26)**

# INTERNATIONAL SEARCH REPORT

Int. l. Application No  
PCT/US 00/20706

<b>A. CLASSIFICATION OF SUBJECT MATTER</b> IPC 7 H04Q7/36 H04B7/005		
According to International Patent Classification (IPC) or to both national classification and IPC		
<b>B. FIELDS SEARCHED</b> Minimum documentation searched (classification system followed by classification symbols) IPC 7 H04Q H04B		
Documentation searched other than minimum documentation to the extent that such documents are included in the fields searched		
Electronic data base consulted during the international search (name of data base and, where practical, search terms used) EPO-Internal, INSPEC		
<b>C. DOCUMENTS CONSIDERED TO BE RELEVANT</b>		
Category °	Citation of document, with indication, where appropriate, of the relevant passages	Relevant to claim No.
X	PAULRAJ A J ET AL: "TAXONOMY OF SPACE-TIME PROCESSING FOR WIRELESS NETWORKS" IEE PROCEEDINGS: RADAR, SONAR & NAVIGATION, GB, INSTITUTION OF ELECTRICAL ENGINEERS, vol. 145, no. 1, 1 February 1998 (1998-02-01), pages 25-31, XP000769921 ISSN: 1350-2395 page 25, paragraph 2.1 -page 26 page 26, paragraph 2.2.2 -page 27 page 27, paragraph 3.1 page 28, column 1 --- -/--	1-76
<input checked="" type="checkbox"/> Further documents are listed in the continuation of box C. <span style="margin-left: 100px;"><input checked="" type="checkbox"/> Patent family members are listed in annex.</span>		
° Special categories of cited documents :		
*A* document defining the general state of the art which is not considered to be of particular relevance *E* earlier document but published on or after the international filing date *L* document which may throw doubts on priority claim(s) or which is cited to establish the publication date of another citation or other special reason (as specified) *O* document referring to an oral disclosure, use, exhibition or other means *P* document published prior to the international filing date but later than the priority date claimed		*T* later document published after the international filing date or priority date and not in conflict with the application but cited to understand the principle or theory underlying the invention *X* document of particular relevance; the claimed invention cannot be considered novel or cannot be considered to involve an inventive step when the document is taken alone *Y* document of particular relevance; the claimed invention cannot be considered to involve an inventive step when the document is combined with one or more other such documents, such combination being obvious to a person skilled in the art. *&* document member of the same patent family
Date of the actual completion of the international search  <p style="text-align: center;">18 October 2000</p>	Date of mailing of the international search report  <p style="text-align: center;">25/10/2000</p>	
Name and mailing address of the ISA European Patent Office, P.B. 5818 Patentlaan 2 NL - 2280 HV Rijswijk Tel. (+31-70) 340-2040, Tx. 31 651 epo nl, Fax: (+31-70) 340-3016		Authorized officer  <p style="text-align: center;">Dheere, R</p>

Form PCT/ISA/210 (second sheet) (July 1992)

INTERNATIONAL SEARCH REPORT

International Application No  
PCT/US 00/20706

C.(Continuation) DOCUMENTS CONSIDERED TO BE RELEVANT		
Category °	Citation of document, with indication, where appropriate, of the relevant passages	Relevant to claim No.
X	<p>WO 98 09381 A (RALEIGH)                      5 March 1998 (1998-03-05)                      page 1, line 14 - line 18                      page 2, line 5 -page 3, line 6                      page 6, line 5 - line 25                      page 7, line 2 - line 17                      page 9, line 22 - line 35                      page 10                      page 11                      page 15, line 5 - line 24                      page 19, line 5 -page 20, line 15                      figure 5A</p>	1-76
A	<p>WO 98 34424 A (AT&amp;T)                      6 August 1998 (1998-08-06)</p> <p>page 3, line 8 - line 13                      page 5, line 17 - line 21</p>	1,18,26, 27,29, 34,41, 43-45, 54,56, 58-60, 62-67, 69,70
A	<p>US 5 592 490 A (ARRAYCOMM)                      7 January 1997 (1997-01-07)</p> <p>column 11, line 10 - line 15                      abstract                      figure 1</p>	1,18,26, 27,29, 34,41, 43-45, 54,56, 58-60, 62-67, 69,70
P,X	<p>US 6 067 290 A (GIGABIT WIRELESS)                      23 May 2000 (2000-05-23)                      the whole document</p>	1-76

# INTERNATIONAL SEARCH REPORT

Information on patent family members

Int: International Application No
PCT/US 00/20706

Patent document cited in search report	A	Publication date	Patent family member(s)	Publication date
WO 9809381	A	05-03-1998	AU 4238697 A EP 0920738 A EP 0931388 A WO 9809385 A WO 9809395 A	19-03-1998 09-06-1999 28-07-1999 05-03-1998 05-03-1998
WO 9834424	A	06-08-1998	US 6052599 A EP 0956722 A	18-04-2000 17-11-1999
US 5592490	A	07-01-1997	US 5515378 A US 5546090 A AU 701764 B AU 4595296 A BR 9510197 A CA 2210859 A CN 1173265 A EP 0804858 A FI 973076 A JP 11504169 T WO 9622662 A WO 9818272 A US 5828658 A AT 183865 T AU 670766 B AU 3145493 A CA 2125571 A DE 69229876 D DE 69229876 T EP 0616742 A EP 0926916 A ES 2137197 T FI 942771 A JP 7505017 T WO 9312590 A US 5625880 A US 5642353 A	07-05-1996 13-08-1996 04-02-1999 07-08-1996 23-12-1997 25-07-1996 11-02-1998 05-11-1997 16-09-1997 06-04-1999 25-07-1996 30-04-1998 27-10-1998 15-09-1999 01-08-1996 19-07-1993 24-06-1993 30-09-1999 30-12-1999 28-09-1994 30-06-1999 16-12-1999 10-06-1994 01-06-1995 24-06-1993 29-04-1997 24-06-1997
US 6067290	A	23-05-2000	NONE	

CORRECTED VERSION

(19) World Intellectual Property Organization  
International Bureau



(43) International Publication Date  
8 February 2001 (08.02.2001)

PCT

(10) International Publication Number  
WO 01/010156 A1

- (51) International Patent Classification<sup>7</sup>: **H04Q 7/36**,  
H04B 7/005
- (21) International Application Number: PCT/US00/20706
- (22) International Filing Date: 28 July 2000 (28.07.2000)
- (25) Filing Language: English
- (26) Publication Language: English
- (30) Priority Data:  
09/364,146 30 July 1999 (30.07.1999) US  
09/545,434 7 April 2000 (07.04.2000) US  
09/564,770 3 May 2000 (03.05.2000) US

1875 Capistrano Way, Los Altos, CA 94024 (US). **SE-BASTIAN, Peroor, K.**; 262 Higdon Avenue, #4, Mountain View, CA 94041 (US). **GESBERT, David, J.**; 180 Beatrice Street, Mountain View, CA 94041 (US). **CHOPRA, Rahul**; 1180 Fewtrell Street, Campbell, CA 95008 (US).

(74) Agent: **VILLENEUVE, Joseph, M.**; Beyer Weaver & Thomas, LLP, P.O. Box 130, Mountain View, CA 94042-0130 (US).

(81) Designated States (*national*): AE, AG, AL, AM, AT, AU, AZ, BA, BB, BG, BR, BY, BZ, CA, CH, CN, CR, CU, CZ, DE, DK, DM, DZ, EE, ES, FI, GB, GD, GE, GH, GM, HR, HU, ID, IL, IN, IS, JP, KE, KG, KP, KR, KZ, LC, LK, LR, LS, LT, LU, LV, MA, MD, MG, MK, MN, MW, MX, MZ, NO, NZ, PL, PT, RO, RU, SD, SE, SG, SI, SK, SL, TJ, TM, TR, TT, TZ, UA, UG, UZ, VN, YU, ZA, ZW.

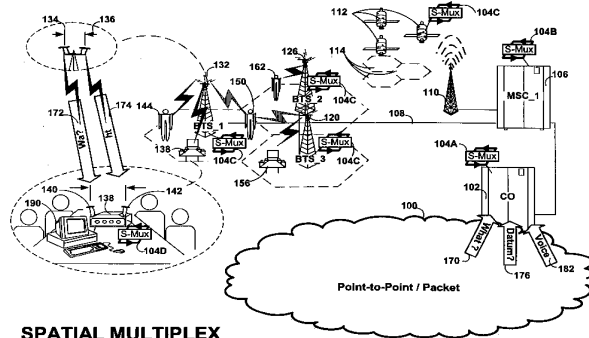
(71) Applicant: **IOSPAN WIRELESS, INC.** [US/US]; 3099 N. First Street, San Jose, CA 95134 (US).

(84) Designated States (*regional*): ARIPO patent (GH, GM, KE, LS, MW, MZ, SD, SL, SZ, TZ, UG, ZW), Eurasian patent (AM, AZ, BY, KG, KZ, MD, RU, TJ, TM), European patent (AT, BE, CH, CY, DE, DK, ES, FI, FR, GB, GR, IE,

(72) Inventors: **PAULRAJ, Arogyaswami, J.**; 59 Peter Coutts Hill, Stanford, CA 94305 (US). **HEATH, Robert, W., Jr.**;

[Continued on next page]

(54) Title: SPATIAL MULTIPLEXING IN A CELLULAR NETWORK



SPATIAL MULTIPLEX

(57) Abstract: The present invention provides methods and apparatus for implementing spatial multiplexing in conjunction with the one or more multiple access protocols during the broadcast of information in a wireless network. A wireless cellular network for transmitting subscriber datastream(s) to corresponding ones among a plurality of subscriber units located within the cellular network is disclosed. The wireless cellular network includes base stations and a logic. The base stations each include spatially separate transmitters for transmitting, in response to control signals, selected substreams of each subscriber datastream on an assigned channel of a multiple access protocol. The logic assigns an available channel on which to transmit each subscriber datastream. The logic routes at least a substream of each datastream to at least a selected one of the base stations. The logic also generates control signals to configure the at least a selected one of the base stations to transmit the selected substreams to a corresponding one among the plurality of subscriber units on the assigned channel. A subscriber unit for use in a cellular system is also disclosed. The subscriber unit includes a plurality of spatially separate antennas and a transmitter for transmitting a plurality of substreams of a datastream on an assigned channel or slot of a multiple access protocol. The transmitter is arranged to apply each substream to an associated one of the spatially separate antennas.

WO 01/010156 A1



IT, LU, MC, NL, PT, SE), OAPI patent (BF, BJ, CF, CG, CI, CM, GA, GN, GW, ML, MR, NE, SN, TD, TG).

**(15) Information about Correction:**

see PCT Gazette No. 36/2002 of 6 September 2002, Section II

**Published:**

— *with international search report*

**(48) Date of publication of this corrected version:**

6 September 2002

*For two-letter codes and other abbreviations, refer to the "Guidance Notes on Codes and Abbreviations" appearing at the beginning of each regular issue of the PCT Gazette.*

## SPATIAL MULTIPLEXING IN A CELLULAR NETWORK

## BACKGROUND OF THE INVENTION

## 1. Field of Invention

5 The field of the present invention relates in general to the field of wireless broadcast of information using one or more multiple access protocols and in particular to methods and apparatus for implementing spatial multiplexing in conjunction with the one or more multiple access protocols during the broadcast of information.

## 10 2. Description of the Related Art

In wireless broadcast systems, information generated by a source is transmitted by wireless means to a plurality of receivers within a particular service area. The transmission of such information requires a finite amount of bandwidth, and in current state of the art transmission of information from different sources, must  
15 occur in different channels.

Since there are quite a few services (e.g. television, FM radio, private and public mobile communications, etc.) competing for a finite amount of available spectrum, the amount of spectrum which can be allocated to each channel is severely limited. Innovative means for using the available spectrum more efficiently are of  
20 great value. In current state of the art systems, such as cellular telephone or broadcast television, a suitably modulated signal is transmitted from a single base station centrally located in the service area or cell and propagated to receiving stations in the service area surrounding the transmitter. The information transmission rate achievable by such broadcast transmission is constrained by the allocated bandwidth.  
25 Due to attenuation suffered by signals in wireless propagation, the same frequency channel can be re-used in a different geographical service area or cell. Allowable interference levels<sup>4</sup> determine the minimum separation between base stations using the same channels. What is needed is a way to improve data transfer speed in the

multiple access environments currently utilized for wireless communications within the constraints of available bandwidth.

#### SUMMARY OF THE INVENTION

5           The present invention provides methods and apparatus for implementing spatial multiplexing in wireless networks such as cellular networks. In various embodiments unique network configuration, base stations and remote (subscriber) units are described. A wide variety of different applications of spatial multiplexing are also described.

10           In some embodiments the wireless cellular network includes base stations having spatially separate transmitters for transmitting in response to control signals and selected substreams of each subscriber datastream on an assigned channel of a multiple access protocol. From the standpoint of the network, the spatially separate transmitters can be located at a single base station or may be located on multiple base  
15           stations. Logic assigns an available channel on which to transmit each subscriber datastream. The logic routes at least a substream of each datastream to at least a selected one of the base stations. The logic also generates control signals to configure at least a selected one of the base stations to transmit the selected substreams to a corresponding one among the plurality of subscriber units on the assigned channel.  
20           Appropriate receivers are also described.

          In other embodiments of the invention, subscriber units for use in cellular systems are disclosed. The subscriber units typically will have both spatially separate transmitters and receivers, although that is not a fixed requirement. In some  
25           embodiments subscriber unit includes spatially separate receivers, a spatial processor, and a combiner. The spatially separate receivers receive the assigned channel composite signals resulting from the spatially separate transmission of the subscriber downlink datastream(s). The spatial processor is configurable in response to a control signal transmitted by the base station to separate the composite signals into estimated substreams based on information obtained during the transmission of known data  
30           patterns from at least one of the base stations or by using blind training techniques. The spatial processor signals the base stations when a change of a spatial transmission configuration is required in order to resolve the composite signals into estimated



downlink datastream(s). The combiner combines the estimated substreams into a corresponding subscriber datastream.

## BRIEF DESCRIPTION OF THE DRAWINGS

These and other features and advantages of the present invention will become more apparent to those skilled in the art from the following detailed description in  
5 conjunction with the appended drawings in which:

FIG. 1 shows a wireless cellular network incorporating spatial multiplexing and multiple access according to the current invention.

FIG. 1B is a detailed view of selected cells within the cellular network shown in FIG. 1A.

10 FIG. 1C shows a cell architecture that provides overlapping regions suitable for multi-base spatial multiplexing.

FIGS. 2A-G show alternate embodiments for the subscriber units utilized in the wireless cellular network shown in FIGS. 1A-B.

15 FIG. 3A shows a detailed hardware block diagram of a single base station and subscriber unit for use in the wireless cellular network shown in FIGS. 1A-B.

FIG. 3B shows a detailed hardware block diagram of a single base station and subscriber unit as in Fig. 3A, wherein the subscriber unit interfaces with a local area network.

20 FIGS. 4A-J show detailed hardware block diagrams of the multiple access hardware for controlling the transmission of subscriber datastream(s) from one or more of the base stations within the wireless network.

FIGS. 5A-B show detailed hardware block diagrams of the hardware associated with the receipt of multiple subscriber datastream(s) at the base stations of the wireless network of the current invention.

25 FIG. 6 shows a detailed view of the signals and the symbols associated with the transmission and receipt of spatially multiplexed signals according to an embodiment of the current invention.

30 FIGS. 7A-B show detailed hardware block diagrams of the configurable spatial processor associated with the receiver circuitry receiver, according to an embodiment of the current invention.

FIGS. 7C-D show detailed hardware block diagrams of a configurable space and space-time processor associated with the configurable spatial receiver according to an embodiment of the current invention.

5 FIG. 8 shows in-band training and data signals for calibrating the spatially configurable receiver during the transmission of spatially multiplexed data, according to an embodiment of the current invention.

FIGS. 9A-B are respectively detailed hardware block diagrams of a spatially multiplexed transmitter and receiver implementing a time-division multiple access protocol (TDMA), according to an embodiment of the current invention.

10 FIGS. 10A-B are respectively detailed hardware block diagrams of a spatially multiplexed transmitter and receiver implementing a frequency-division multiple access protocol (FDMA), according to an embodiment of the current invention.

15 FIGS. 11A-B are respectively detailed hardware block diagrams of a spatially multiplexed transmitter and receiver implementing a code-division multiple access protocol (CDMA), according to an embodiment of the current invention.

FIGS. 12A-B are respectively detailed hardware block diagrams of a spatially multiplexed transmitter and receiver implementing a space-division multiple access protocol (SDMA), according to an embodiment of the current invention.

20 FIGS. 13A-B are process flow diagrams showing the acts associated with respectively the spatially multiplexed transmission and reception of datastream(s) in any one of a number of multiple access protocols, according to an embodiment of the invention.

FIG. 14 is a diagrammatic illustration of a hybrid DSL/wireless link that incorporates a spatially multiplexed remote wireless device.

25 FIG. 15 is a diagrammatic illustration of a hybrid cable/wireless link that incorporates a spatially multiplexed remote wireless device in a network access unit.

FIG. 16 is a diagrammatic illustration of a repeater BTS that utilizes a spatially multiplexed remote wireless device.

DETAILED DESCRIPTION OF THE EMBODIMENTS

A method and apparatus is disclosed which allows for both spatial multiplexed and non-spatial wireless communications between portable units and corresponding selected ones among a plurality of base stations. The methods and apparatus of the current invention may be implemented on a dedicated wireless infrastructure or may  
5 be superimposed on existing wireless communications systems, such as cellular telephone and paging services, which are currently in place around the world. The methods and apparatus include implementation in any of a number of multiple access protocols.

#### Spatial Multiplexing and Multiple Access

10 Spatial multiplexing (SM) is a transmission technology which exploits multiple antennas at both the base station(s) and at the subscriber units to increase the bit rate in a wireless radio link with no additional power or bandwidth consumption. Under certain conditions, spatial multiplexing offers a linear increase in spectrum efficiency with the number of antennas. Assuming, for example,  $N=3$  antennas are  
15 used at the transmitter and receiver, the stream of possibly coded information symbols is split into three independent substreams. These substreams occupy the same channel of a multiple access (MA) protocol, the same time slot in a time-division multiple access (TDMA) protocol, the same frequency slot in frequency-division multiple access (FDMA) protocol, the same code/key sequence in code-division  
20 multiple access (CDMA) protocol or the same spatial target location in space-division multiple access (SDMA) protocol. The substreams are applied separately to the  $N$  transmit antennas and launched into the radio channel. Due to the presence of various scattering objects (buildings, cars, hills, etc.) in the environment, each signal experiences multipath propagation. The composite signals resulting from the  
25 transmission are finally captured by an array of receive antennas with random phase and amplitudes. For every substream the set of  $N$  received phases and  $N$  received amplitudes constitute its spatial signature.

At the receive array, the spatial signature of each of the  $N$  signals is estimated. Based on this information, a signal processing technique is then applied to separate  
30 the signals, recover the original substreams and finally merge the symbols back together. Linear or nonlinear receivers can be used providing a range of performance and complexity trade-offs. A linear spatial multiplexing receiver can be viewed as a

bank of superposed spatial weighting filters, where every filter aims at extracting one of the multiplexed substreams by spatially nulling the remaining ones. This assumes, of course, that the substreams have different signatures.

If the transmitter is equipped with M antennas, while the receiver has N  
5 antennas, the rate improvement factor allowed by spatial multiplexing is the minimum of these two numbers. Additional antennas on the transmit or receive side are then used for diversity purposes and further improve the link reliability by improving, for example, the signal-to-noise ratio or allowing for smaller fading margins, etc. Effectively spatial multiplexing allows a transmitter receiver pair to communicate in  
10 parallel through a single MA channel, hence allowing for a possible N-fold improvement of the link speed. More improvement is actually obtained if we take into account the diversity gain offered by the multiple antennas (for instance, in a Raleigh fading channel). Such performance factors are derived ideally under the assumption that the spatial signatures of the substreams are truly independent from  
15 each other. In reality, the level of independence between the signatures will determine the actual link performance. The performance, however, usually exceeds that obtained by a single antenna at the transmitter and receiver. For example, at two GHz, assuming the base station and the subscriber unit are spaced apart by one mile and using three antennas at each end of the link, a scattering radius of about 30 feet  
20 (both ends) is enough to achieve maximum performance.

FIG. 1A shows a plurality of subscriber units wirelessly coupled over a cellular network to a network 100. Network 100 may include: a local area network (LAN), a wide area network (WAN), a public switched telephone network (PSTN), Public Land Mobile Network (PLMN), an adhoc network, a virtual private network,  
25 an intranet or the internet. The wireless system includes: a central office (CO) 102, a master switch center (MSC) 106, a ground based relay station 110, satellites (112), base stations 120, 126 and 132 (BTS) and subscriber units 156, 138, 144, 150 and 162. The subscriber units may be mobile, fixed or portable. The base stations may be fixed or mobile. The base stations may include: a tower, satellites, balloons, planes,  
30 etc. The base station may be located indoors/outdoors. The cellular network includes one or more base stations, where each base station includes one or more spatially separate transmitters.

The central office 102 is coupled to the network 100. Network 100 may be circuit switched (e.g. point-to-point) or packet switched network. The central office is coupled to a master switching center 106. The MSC in traditional cellular systems is alternately identified as: a mobile telephone switching office (MTSO) by Bell Labs, 5 an electronic mobile Xchange (EMX) by Motorola, an AEX by Ericsson, NEAX by NEC, a switching mobile center (SMC) and a master mobile center (MMC) by Novatel. The MSC is coupled via data/control line 108 to the satellites via relay station 110 and to the base stations. In an alternate embodiment of the invention, base station controllers (BSC) may serve as intermediary coupling points between the 10 MSC and the base stations. In the embodiment shown, each of the BTS includes an array of spatially separate antennas for transmission and/or reception. The BTS may also include traditional antenna for whichever of the receive/transmit side of its communication capability lacks spatially separate antenna and associated circuitry. Antennas of a transmitter/receiver are defined to be spatially separate if they are 15 capable of transmitting/receiving spatially separate signals. Physically separate antenna may be used to transmit/receive spatially separate signals. Additionally, a single antenna may be used to transmit/receive spatially separate signals provided it includes the ability to transmit/receive orthogonal radiation patterns. Hereinafter, the phrase "spatially separate" shall be understood to include any antenna or transmitter 20 or receiver capable of communicating spatially separate signals. The base stations are configured to communicate with subscriber units of a traditional type, i.e. those lacking either spatially separate transmission/reception as well as spatially enabled subscriber units, i.e. those including either or both spatially separate reception and transmission capabilities.

25 In operation, distinct subscriber datastream(s) 170, 176 and 182 are received by CO 102. The CO performs the initial routing of the data streams to the appropriate one of a plurality of MSCs which may be located across the country. The MSC performs several functions. It controls the switching between the PSTN or network 100 and the BTSs for all wireline-to-subscriber, subscriber-to-wireline and subscriber- 30 to-subscriber calls. It processes/logic data received from BTSs concerning subscriber unit status, diagnostic data and bill compiling information. In an embodiment of the invention, the MSC communicates with the base stations and/or satellites with a datalink using the X.25 protocol or IP protocol. The MSC also implements a portion

of the spatial multiplexing and multiple access processes/logic (SM\_MA) 104B of the current invention. Each BTS operates under the direction of the MSC. The BTS and satellites 112 manage the channels at the site, supervise calls, turn the transmitter/receiver on/off, inject data onto the control and user channels and perform  
5 diagnostic tests on the cell-site equipment. Each BTS and satellite also implement a portion of the SM\_MA processes/logic 104C. The subscriber units may be both traditional and spatially enabled and may still communicate over the system. Those subscriber units that are spatially enabled on either/both the transmit/receive side of communications implement SM\_MA processes/logic 104D as well.

10 The SM\_MA processes/logic allow high bit rate communications with any of the SM\_MA enabled subscriber units within existing bandwidth constraints and within any of the multiple access (MA) protocols common to wireless communications or combinations thereof. Those MA protocols include: time-division multiple access (TDMA), frequency-division multiple access (FDMA), code-division  
15 multiple access (CDMA), space-division multiple access (SDMA) and many other multiple access protocols known to those skilled in the art. The SM\_MA processes/logic include the ability to selectively allocate spatially separate downlink or uplink capability to any spatially enabled subscriber within a multiple access environment. This capability allows, as to that subscriber, the elevation of bit rates  
20 well above those currently available. Thus, a whole new range of subscribers can be anticipated to take advantage of this capability. Utilizing this invention, it will be possible to provide a wireless medium for connecting workstations, servers and tele-video conferences using the existing cellular infrastructure with the adaptations provided by this invention. The SM\_MA processes/logic involve splitting subscriber  
25 datastream(s) destined for spatial multiplexing into substreams and intelligently routing and re-routing the substreams during a call session so as to maintain consistent quality of service (QoS). The substreams are communicated on the same channel using the same access protocol, thus not requiring additional resources or bandwidth to implement. The processes/logic include: access protocol assignment,  
30 channel assignment, monitoring of spatial separation, determination/re-determination of spatial signatures for each communication link, routing/re-routing between single-BTS and multi-BTS, handoff and control of substream parsing/combining.

In FIG. 1A, datastream(s) 170, 176 and 182 are shown originating on network 100. The SM\_MA processes/logic 104 have parsed and routed subscriber data stream 170 into substreams 172-174, which are transmitted on a single channel of a multiple access protocol over the spatially separate antenna 134-136 of BTS 132. Subscriber unit 138, via spatially separate antenna 140-142, receives composite signals 172-174 resulting from the substream transmission and utilizing SM\_MA processes/logic 104D, derives the substream and original datastream 170 therefrom. In the embodiment shown, the data is delivered to the computer 190 to which the fixed subscriber desktop unit 138 is coupled. The cellular environment may also be implemented utilizing aerial equivalents of the base stations. In the embodiment shown, a plurality of satellites 112 generally deliver subscriber datastream(s) via spatially separate antennae on each of the satellites to a cellular network, i.e. 114.

In a circuit-switched embodiment of the invention, a call over a cellular network may require using two channels simultaneously; one called the user channel and one called the control channel. The BTS(s) transmit and receive on what is called a forward/downlink control channel and the forward/downlink voice/data channel and the subscriber unit transmit/receive on the reverse/ uplink control and voice/data channels. Completing a call within a cellular radio system is quite similar to the PSTN. When a subscriber unit is first turned on, it performs a series of startup procedures and then samples the received signal strength on all user channels. The unit automatically tunes to the channel with the strongest receive signal strength and synchronizes to the control data transmitted by the BTS(s). The subscriber unit interprets the data and continues monitoring the controlled channels. The subscriber unit automatically re-scans periodically to ensure that it is using the best control channel. Within a cellular system, calls can take place between a wireline party and a subscriber unit or between two subscriber units. For wireline-to-subscriber unit calls, the MSC receives a call from either a wireline party or in the form of a call setup packet from the network 100. The MSC determines whether the subscriber unit to which the call is destined is on/off hook. If the subscriber unit is available, the MSC directs the appropriate BTS to page the subscriber unit. The subscriber unit responds to the BTS indicating its availability and spatial multiplexing capabilities, receive and/or transmit. Following the page response from the subscriber unit, the MSC/BTS switch assigns an idle channel, configures spatial processing capability on both the



subscriber unit and BTS(s) if appropriate, and instructs the subscriber unit to tune to that channel. The subscriber unit sends a verification of channel tuning to the BTS(s) and then sends an audible call progress tone to the subscriber I/O unit causing it to ring. The switch terminates the call progress tone when it receives positive indication  
5 the subscriber has answered and the conversation or communication has begun.

Calls between two subscriber units are also possible in the cellular radio system. To originate a call to another subscriber unit, the calling party enters the called number into the unit's memory via the touch pad and then presses the send key. The MSC receives the caller's identification number and the called number then  
10 determines if the called unit is free to receive the call. The MSC switch sends a page command to all base stations and the called party, who may be anywhere in the service area, receives the page. The MSC determines the spatial multiplexing capability of both subscribers. Following a positive page from the called party, the switch assigns each party an idle user channel and instructs each party to tune into  
15 that respective channel. Then the called party's phone rings. When the system receives notice the called party has answered the phone, the switch terminates the call progress tone and a communication can begin between two subscriber units. If spatial multiplexing is enabled, the communication link will include that capability.

One of the most important features of the cellular system is its ability to  
20 transfer calls that are already in progress from one cell site/base station to another as a subscriber unit moves from cell to cell or coverage area to coverage area within the cellular network. This transfer process is called a handoff. Computers at the BTS transfer calls from cell to cell with minimal disruption and no degradation in quality of transmission. The handoff decision algorithm is based on variations in signal  
25 strength. When a call is in progress, the MSC monitors the received signal strength of each user channel. If the signal level on an occupied channel drops below a predetermined threshold for more than a given time interval, the switch performs a handoff provided there is a vacant channel. In a traditional non-SM cellular system a traditional handoff involves switching the transmission point of a subscriber session  
30 (datastream) from one BTS to another. In the current invention various types of handoff, e.g. partial and full may take place. The handoff operation may involve the MSC re-routing the call and the entire datastream or selected substreams thereof to different antennas of the same BTS or to a new BTS/BTSs in whole or in part. Where

the re-routing is partial, at least one substream communication path is left unchanged while other of the substreams are re-routed to antennas on another BTSs. Where the handoff is full the multiple substreams transmitted from one or more BTSs are re-routed to other BTS(s).

5           In an embodiment of the invention utilizing a packet switched architecture, call setup may be implemented using protocols including: ALOHA, slotted-ALOHA, carrier sense multiple access (CSMA), TDMA, FDMA, CDMA, SDMA, etc., or any combination thereof.

          BTS 132, in the embodiment shown, includes spatially separate antenna array.  
10       There may be any number of antennas. In some spatial environments, baud rates for spatially multiplexed communications on a single channel will increase linearly with the number of antennas allocated by subscriber unit and BTSs to a call session. In the embodiment shown, each BTSs array includes at least two antennas 134 and 136. The  
15       BTS may include either or both spatial multiplexing capability on the downlink (transmit) or uplink (receive) side. In the embodiment shown, each BTS includes  
spatial multiplexing capability on both the downlink and uplink. Although each of the  
following embodiments utilizes two antennas to implement SM, any number of  
antennas on a single BTS or multiple BTSs may be utilized without departing from  
the scope of the invention.

20           FIG. 1B shows a more detailed view of the BTS and subscriber units shown in FIG. 1A. Each BTS includes two spatially separate antennas. BTS 120 includes  
antennas 122-124. BTS 126 includes antennas 128-130. BTS 132 includes antennas  
134-136. In the embodiment shown, many of the subscriber units also include at least  
25       two spatially separate antennas. Subscriber unit 150 includes spatially separate  
antennas 152-154. In the embodiment shown, the MSC handles the routing of  
subscriber datastream(s) 170, 176 and 182 from network 100 to the appropriate BTSs  
for transmission to the appropriate subscriber unit. In an embodiment of the  
invention, the SM\_MA processes/logic include the ability to determine whether to  
30       implement or not implement spatial multiplexing (SM), based on either the  
presence/absence of SM capabilities in the corresponding subscriber unit and/or on  
the nature of the datastream. If, for example, the subscriber lacks SM capability on  
either or both the uplink/downlink, then the corresponding datastream will not be

parsed into substreams. Alternately, even if the subscriber unit and BTS have SM capability on both downlink and uplink, certain types of datastream(s) may not require SM processing. Examples of these might include: traditional voice call sessions, call sessions which require only low QoS or datastream(s) which require  
5 only very low bit rates or are susceptible to buffering and delayed transmission.

In the example shown in FIG. 1B, datastream 182 is traditional mode traffic, e.g. a subscriber telephone call between an upstream subscriber and the subscriber unit 144. Subscriber unit 144 is located within a cell serviced by BTS 132. Under the control of MSC 106, the datastream 182 is transmitted over signal line 108 directly to  
10 the corresponding base station 132 without being split or parsed into associated substreams. In the example shown, datastream(s) 182 is transmitted from a single antenna, e.g. antenna 134, without any SM techniques. That transmission is received by the subscriber unit 144. As discussed above, subscriber unit 144 may be a  
15 traditional cell phone lacking SM capability. Alternately, subscriber unit 144 may be SM enabled but, nevertheless, receives the call in traditional mode after appropriately configuring itself to opt out of SM receive side processes/logic, electing instead traditional mode.

In the example shown, datastream(s) 170 is handled using SM\_MA processes/logic 104\_. The datastream 170 and/or substreams thereof, depending on  
20 the embodiment, is routed by the MSC to BTS 132. The processes/logic 104 provide to each antenna 134-136 of BTS 132 a single substream derived from the original datastream 170, on a common channel within the appropriate access protocol. Those substreams are received as composite signals by the spatially separate antenna 140-142 (see FIG. 2B) of subscriber unit 138. The subscriber unit 138, utilizing SM-MA  
25 processes/logic 104D, derives the substreams from the composite signals and combines these into the initially transmitted datastream(s) 170.

Datastream(s) 176 is also subject to SM\_MA processes/logic 104\_. The datastream 176 and/or substreams thereof, depending on the embodiment, is routed by the MSC, initially to BTS 132 for single-base transmission to subscriber unit 150.  
30 SM-MA processes/logic implemented collectively at the MSC 106 and BTS 132 result in the splitting/parsing of the datastream(s) 176 into substreams 178-180. Initially those substreams are received as composite signals by the spatially separate

antenna 152-154 (see FIG. 2C) of subscriber unit 150. The subscriber unit 150, utilizing SM\_MA processes/logic 104D, derives the substreams from the composite signals and combines these into the initially transmitted datastream(s) 176.

5 Implementing SM or SM\_MA communications between the BTS and the associated subscriber unit may be either line-of-site (LOS) or multipath. Multipath communications are likely in environments, such as a city, where buildings and other objects deflect signals transmitted from the BTS many times before their arrival at the subscriber unit. Under certain conditions, it may be the case that transmissions originating from spatially separate antennas of a single BTS may arrive at a subscriber  
10 unit along signal paths which cannot be spatially separated by the antenna array on the subscriber unit. Where this is the case, it may be necessary for the processes/logic to reconfigure the spatial transmission characteristics of the substreams so that they may be received at the corresponding portable unit in a manner which is spatially separable. In the example shown, the substreams 180 and 178\_S are transmitted  
15 initially from a single BTS 132. When a determination is made, either by the BTS or subscriber unit that separation of the substreams is not possible, a spatial reconfiguration is initiated by the spatial multiplexing processes/logic 104. The determination might, for example, result from the subscriber unit signaling the BTS or from the BTS determining that the bit error rate (BER) of the transmission exceeded  
20 an acceptable level. In an alternate embodiment of the invention in which base and subscriber communicate over a common channel, the signaling from the subscriber to the base station(s) for a change of a spatial transmission configuration is simplified. The BTS may, by analyzing the received signals, determine that they can not be adequately separated and in response, alter the spatial configuration of the  
25 transmissions to the subscriber unit with which it shares a channel. In the example shown, this reconfiguration results in a change of spatial configuration to multi-base transmission. Substream 178\_M is re-routed through BTS 120 and specifically antenna 122. Because subscriber unit 150 is positioned in an area in which the transmissions from BTS 120 and 132 overlap, the change in spatial configuration is  
30 possible. The increased spatial separation on the transmit side increases likelihood that the substreams can be spatially separated by the subscriber unit 150 and its associated SM-MA processes/logic 104D.

FIG. 1C shows another embodiment of the current invention in which a cell architecture which provides overlapping regions suitable for multi-base spatial multiplexing is shown. As in normal cellular structure, co-channel interference is avoided by ensuring that cells operating in the same frequency are spaced apart. In the example shown, BTSs 186A-C form an overlapping region between them in which they are shown in spatially multiplexed communication with subscriber unit 138. BTSs 186C-E form an overlapping region between them, in which they are shown in spatially multiplexed communication with subscriber unit 150A. BTSs 186C, F-G also form an overlapping region between them, in which they are shown in spatially multiplexed communication with subscriber unit 150B. The communications with subscriber units 138, 150A-B are conducted on separate channels to avoid co-channel interference. Diversity techniques can be simultaneously implemented. More distant cells may re-use the same channels provided co-channel interference is tolerable.

FIGS. 2A-G show alternate embodiments of subscriber units which may be either fixed, portable or mobile. FIG. 2A shows a mobile cellular phone 144 with a single antenna 146. In an embodiment of the invention, the single antenna includes the capability of transmitting and/or receiving spatially separable signals utilizing orthogonal di-poles. In an alternate embodiment of the invention, subscriber unit 144 is a traditional cellular phone which does not have the capability of transmitting/receiving a spatially separable signal. Either embodiment may be compatible with the system shown in FIGS. 1A-B, provided that system includes an embodiment of the invention with the ability to detect the transceiver capabilities of the subscriber units and to configure communications between that unit and the corresponding BTS accordingly.

FIG. 2B shows a fixed subscriber unit 138 coupled to a computer 190. In this embodiment, high-speed data communications between computer 190 and a wireless communication network with spatial multiplexing capabilities is enabled by fixed subscriber unit 138. Fixed subscriber unit 138 is shown with an antenna array including antennas 140-142. In the embodiment shown, additional antennas are provided. These may be utilized either for spatial multiplexing or to implement receive/transmit processing, e.g. diversity techniques, beam forming, interference cancellation, etc., the latter for the purpose of improving communication quality and

link budget. The current state of the art requires a minimum separation between antennas 140-142, i.e. D1 equivalent to 1/2 the carrier wavelength. Further improvements in signal processing may avoid this requirement.

FIG. 2C shows a mobile subscriber unit, i.e. a cellular telephone 150,  
5 reconfigured for implementation of SM or SM\_MA on either or both of the transmit (uplink) or receive (downlink) side of its communication with the BTSs. To this end, the antennas 152-154 are provided.

FIG. 2D shows a personal digital assistant (PDA) 200 and associated docking station 202 configured to implement SM or SM\_MA communications on either or  
10 both the transmit and receive portions of its communications. To this end, the antenna array, which in the embodiment shown, includes two antennas 204-206 is provided. An example of personal digital assistants currently on the market that could be configured to utilize the current invention is the Palm Pilot™ product sold by 3Com Corporation.

FIG. 2E shows a mobile subscriber unit 210 implemented as part of an  
15 automobile 216. The antenna array associated with this unit is not shown. The use of SM or SM\_MA wireless communications between vehicles and base stations can provide such benefits as vehicle navigation, routing, and diagnostics.

FIG. 2F shows a notebook computer 220 configured for SM or SM\_MA  
20 communication utilizing an antenna array with antennas 222-224 and associated hardware and processes/logic.

FIG. 2G shows a fixed subscriber unit 138 incorporated into a wireless router or bridge 235, which is coupled to a wired network 240. In this embodiment, the subscriber unit 138 serves as a high speed wireless connection between the wired  
25 network and the wireless communication network. The network 240 can take any suitable form including a local area network, a wide area network, an intranet, etc. It should be appreciated that in this arrangement, a wireless link is simply being used to connect two networks and such wireless links can be used in a wide variety of applications. For example, the wireless link can be used to provide high speed  
30 Internet access to the network 240. In the embodiment shown, the fixed subscriber unit 138 is shown as being incorporated into a router or bridge 235. However, it should be appreciated that the subscriber unit can readily be incorporated into a

variety of network components having a variety of functionalities. For example, the router or bridge can further include firewall capabilities, etc.

FIG. 3A is a detailed hardware block diagram of a subscriber unit 138 and a  
BTS 132. The BTS 132 includes: a multiple access spatial transmitter 310, a multiple  
5 access spatial receiver 330, a controller module 320 and upstream processes/logic  
300, further details of which are provided in the accompanying FIGS. 4-5. The  
subscriber unit 138 includes: a multiple access spatially configured receiver 380, a  
multiple access spatially configured transmitter 350 and a control unit 370. The  
multiple access spatial transmitter 310 includes: a selector 312, a final transmission  
10 stage 316 and optionally may include transmit processes/logic 314. The final stage  
transmitter 316 is coupled to a spatially separate antenna array which includes  
antennas 134T-136T.

In operation, the subscriber datastream(s) and/or substreams thereof are  
provided to the selector 312 from the upstream processes/logic 300. Utilizing either  
15 in band or out of band control signals embodied in the datastream(s)/substreams  
themselves or separately communicated from the SM\_MA processes/logic at the MSC  
106 or elsewhere, the selector implements the MA protocol utilized by the wireless  
network. That protocol, as discussed above, may include: TDMA, FDMA, CDMA or  
SDMA, for example. The selector places each of the datastream(s)/substreams on the  
20 appropriate channel. Each of the datastream(s)/substreams are then passed through  
the optional transmit processes/logic, in which any of a number of well-known prior  
art signal processing techniques may be implemented to improve the quality of  
transmission. These techniques include, but are not limited to, diversity processing,  
space coding, space-time coding, space-frequency coding, and beam forming and  
25 interference canceling. The datastream(s)/substreams are then passed to the final  
transmit stage 316. Traditional mode traffic may be routed by the SM\_MA  
processes/logic 104 to the appropriate antenna 134T-136T for transmission. If  
diversity processing is implemented, even traditional mode traffic may be transmitted  
using multiple antennas. Spatial mode traffic, i.e. the individual substreams thereof,  
30 will be routed to the appropriate one of the two antennas 134T-136T.

On the receive side, the subscriber unit SM\_MA configurable receiver 380  
includes: receiver first stage 382, optional receive processes/logic 384, spatial/space-

time processor 386, decoder 388, combiner 390 and I/O module 392. The receiver first stage is coupled to a spatially separate antenna array, e.g. antennas 140R-142R. Utilizing in/out of band control signals, the SM\_MA configurable receiver 380 of the subscriber unit 138, in the embodiment shown, may be configured for

5 spatial/traditional mode signal reception on the requisite channel within the multiple access protocol. In the case of spatial mode communications, the antenna array, e.g. antennas 140R-142R, detect downlink composite signals derived from the spatially separate transmission of the substreams through antennas 134T-136T. These composite signals are down converted, demodulated and sampled by the receiver first

10 stage 382. The composite signals are then passed to the receive processing module 384 and may be subject to receive side processing if implemented. From the receive processing module, the composite signals are passed to the spatial processor 386. The spatial/space-time processor via in/out band control signals is also configured to derive the appropriate number of substreams, i.e. equivalent to the number

15 transmitted, from the BTS(s). Utilizing logic associated with space/space-time processing (see FIGS. 7A-D), that processor, in conjunction with decoder 388, generates estimated source substreams which are passed to the combiner 390. The combiner 390 via in/out band control signals is also configured to combine the substreams into an estimated subscriber datastream(s) corresponding to that

20 transmitted from the BTS 132. The datastream(s) are passed to the I/O module for presentment/delivery as, e.g., audio, image or data. Where communications are asymmetric, the uplink may, in an embodiment of the invention, not include SM capability, leaving that capability to the downlink alone. This asymmetric capability may be implemented on either the downlink or the uplink without departing from the

25 scope of this invention.

The uplink from the subscriber unit 138 to the BTS 132 may use the same or different hardware/firmware/processes/logic to that utilized for the downlink. In an embodiment of the invention, the uplink is traditional with no SM\_MA capability. In the embodiment shown in FIG. 3A, the uplink includes both SM and MA

30 processes/logic. The datastream(s) received by the I/O module 352 are passed to parser 354. In an embodiment of the invention, the parser is configurable to generate a traditional datastream or a variable number of substreams thereof. In another embodiment of the invention, the parser parses all datastream(s) into a fixed number



of substreams. Where there are no SM uplink capabilities there is no parser. In other embodiments of the invention, the configurable parser also includes a mode detector to determine whether the datastream(s) should be split into substreams. That determination, as discussed above, may be based on any number of criteria including, but not limited to, traditional vs. spatial mode, QoS, bit rate requirement, feasibility, etc. In such an embodiment, when the mode detector determines that spatial mode transmission of the datastream is appropriate, the parser will split the datastream(s) into a plurality of substreams, the number of which may itself be configurable. These substreams are then passed to the selector 356. The selector responsive to in/out of band control signals implements the appropriate access protocol, including the placement of the datastream(s) and/or substreams onto the appropriate channel within that protocol. The datastream(s) and/or substreams thereof are then optionally passed to transmit processes/logic 358, which may implement any number of well-known prior art signal processing techniques, including the above discussed diversity methodology, to improve signal reception. The substreams and/or datastream(s) are then passed to the final transmit stage 360 where they are encoded, modulated, and up-converted for transmission on a single channel through spatially separate transmit antennas 140T-142T. Composite signals corresponding thereto are received by antennas 134R-136R of the SM\_MA configurable receiver 330 of the BTS.

As discussed above, where the uplink is asymmetric, the BTS may not implement or require SM on the uplink. Nevertheless, in the embodiment shown, the receiver 330 is SM\_MA configurable. The receiver 330 includes a first stage receiver 332, mobility detector 334, receive processes/logic 336, spatial/space-time processor 338 and a decoder 340. The composite signals are passed by antennas 134 R-136 R to the first stage receiver. This is configurable to receive the communications on the appropriate channel within the MA protocol as determined by SM\_MA processes/logic 104. These composite signals are down-converted/demodulated and sampled. In an embodiment of the invention, the mobility detector 334 monitors the composite signals for Doppler shift/spread. Doppler shift/spread of the composite signals correlates with the mobility or lack thereof of the subscriber unit. The absence of a Doppler shift/spread indicates that the subscriber unit is fixed. This determination on the part of the mobility detector may be used to initiate one or more of the following processes/logic: spatial reconfiguration, training/retraining of the

spatial/space-time processors and/or handoff. In an embodiment of the invention in which non-blind in band training is implemented, training/retraining may include varying the training interval or duration or selection of a different training sequence. The composite signals are then passed to the optional receiver processes/logic 336.

5 These processes/logic, as described above, may include any of a number of well-known techniques including diversity processing. The composite signals are then passed to the configurable space/space-time processor 338. Utilizing in/out of band control signals from the MSC and/or the subscriber unit, the space/space-time processor configures itself to generate a number of substreams or a single

10 datastream(s) equivalent to those transmitted from the corresponding subscriber unit. These estimated subscriber substreams/datastream(s) are then passed to the decoder 340. The decoder decodes the symbols to their corresponding binary equivalent. The datastream(s) and/or substreams are then passed to upstream processes/logic 300.

Both the subscriber unit 138 and the BTS 132 are shown to include

15 respectively control modules 370 and 320. These control modules implement a subset of the control processes/logic 104 required to implement the SM\_MA processes, such as training of the space/space-time processors 338 and 386, etc.

#### Training

Training refers to the requirement that, in order to implement a space/space-time processing on the receive side of whichever link down/up is implementing SM, it

20 is necessary that the space/space-time processor be equipped with an appropriate model of the spatial characteristics of the environment in which the signals will be passed between the subscriber unit and the associated BTS(s). Different types of training methodology may be appropriate, depending on whether the subscriber units

25 are fixed/mobile, and if mobile, depending on the speed at which they are moving. Where a subscriber unit is fixed, training may be accomplished on installation of the unit, at setup of a call or during a call session. Where a subscriber unit is mobile, training/retraining must take place continuously or intermittently. Training for a fixed subscriber unit may take place intermittently as well, although generally at a lower

30 frequency than that associated with a mobile subscriber unit.

Training is generally categorized as blind or non-blind. Training is non-blind when it is incorporated intermittently/continuously using in/out of band training

signals, e.g. known sequences such as Walsh codes, transmitted between subscriber unit and BTS(s). Training is blind when it takes place without such signals, relying instead on non-Gaussianity, CM, FA, cyclostationarity or the spatial structure, such as the array manifold. The performance of blind methods will, of course, be sensitive to the validity of structural properties assumed. An excellent reference on the subject, which is incorporated herein by reference as if fully set forth herein, is found in: *"Space-Time Processing for Wireless Communications"*, Arogyaswami J. Paulraj and Papadias, IEEE Signal Processing Magazine, November 1997, at pages 49-83. In an embodiment of the invention, non-blind training methods are utilized to configure the space/space-time processors. Further details on the space/space-time processor will be provided in the following FIGS. 7A-D and accompanying text.

Control module 320 includes: processor 324, clock 326, training module 328 and memory 322 for the storage of weights/parameters for the space/space-time processor 338. Control module 370 in the subscriber unit 138 includes: processor 374, clock 376, training module 378 and memory 372 for the storage of weights/parameters for the space/space-time processor 386. In the embodiment of the invention shown in FIG. 3, the CPU implements the training portion of the control processes/logic 104. In alternate embodiments of the invention, the CPU may be utilized to implement other of the control processes/logic. In still other embodiments of the invention, the training portion of the control processes/logic is handled upstream at such locations as the MSC or the CO.

In an embodiment of the invention which implements non-blind training, the mobility detector 334 signals the CPU 324 when a subscriber unit exhibits minimal Doppler shift/spread, e.g. is fixed. In an embodiment of the invention, the CPU 324 directs the transmit module 310 to signal subscriber unit 138 at call setup, or at the start of a call session, to use stored parameters from an earlier training session or to process a setup training session transmitted by the BTS. In another embodiment of the invention, the CPU may reduce the frequency or duration of a training sequence responsive to a determination that the Doppler shift/spread is minimal.

On the BTS side, the training module 328 inserts a known training sequence, e.g. Walsh code, into the downlink transmissions and these are processed by the CPU 374 of the subscriber unit and weights derived therefrom which allow the

space/space-time processor 386 to separate the training sequence spatially broadcast from the antenna array of the BTS(s). Similarly, where the uplink implements SM, the subscriber unit training module 378 inserts a known training sequence into the uplink transmissions as well. These are in turn processed by the CPU 324 and  
5 appropriate weights derived therefrom stored in the spatial processor 338 for use with the uplink communications during the call/data-transfer session. Whenever training/re-training takes place, weights are recalculated and stored for use in subsequent SM communications.

Where the mobility detector 334 determines that the subscriber unit is mobile,  
10 an alternate non-blind training methodology may be implemented. In an embodiment of the invention, that methodology shown in FIG. 8 involves inserting into in/out of band downlink communications the known training sequence. This allows updating of the spatial parameters/weights by the corresponding subscriber unit and its space/space-time processor. This capability allows spatial multiplexing to be  
15 implemented in both a mobile and a fixed environment. In still another embodiment of the invention, the duration/frequency at which the training intervals are inserted into the up/down link communications may be varied depending on the mobility of the subscriber unit.

In still another embodiment of the invention, blind training methods may be  
20 implemented. These unsupervised methods do not need training signals because they exploit the inherent structure of the communication signals.

As will be obvious to those skilled in the art, the processes/logic 104 and the associated modules/blocks discussed above and in the following disclosure may be implemented in hardware, software, firmware or combinations thereof without  
25 departing from the teachings of this invention. They may be implemented on a single chip, such as a digital signal processor (DSP), or application specific integrated circuits (ASIC). On the upstream side (i.e., BTS, MSC, CO, etc.), the SM\_MA processes/logic 104 may physically reside in any one or all upstream units. The processes/logic may be implemented using master-slave control relationship between  
30 CO/MSC and BTS or peer-to-peer control relationship between BTSs alone, or distributed control between CO/MSC and BTS.

FIG. 3B illustrates a detailed hardware block diagram of a subscriber unit 138 and a BTS 132 similar to the system described in FIG. 3A. The difference in this embodiment is that the subscriber unit is connected to a network 240 and thus the I/O modules 352 and 392 in the transmitter 350 and receiver 380 respectively are coupled to the network 240. Of course, the subscriber unit could readily communicate with any type of network or network device.

FIGS. 4A-F show an embodiment of the BTS/MS/CO side of the processes/logic 104\_ for implementing SM\_MA. FIGS. 4A-B and 4D-E show a partial handoff.

FIG. 4A shows BTSs 120 and 132 coupled to MSC 106 and to the associated upstream processes/logic 300 of processes/logic 104\_. The BTS 120 is shown with the associated final transmission stage 316B and the selector 312B. The BTS 132 is shown coupled to the final transmission stage 316A and to the selector 312A. The upstream processes/logic 300 include a detector 400, parser unit 402 and router 420. The parser unit 402 includes a parser module 404 and clock 406 as well as a stretcher 408 and its clock 410. The MSC 106 is shown coupled via its data/control line 108 to each of the above-discussed modules.

As will be obvious to those skilled in the art, the coupling between the MSC and each of the above-discussed hardware and software modules represents a master/slave embodiment of the current invention. In alternate embodiments of the invention, peer-to-peer control methodology may be utilized instead. In still another embodiment of the invention, distributed control methodology may be implemented, e.g. each of the above-discussed modules may contain additional intelligence, sufficient to signal downstream/upstream modules as to the appropriate configuration to adopt, responsive to the datastream(s)/substreams being processed, the channel and access methodology to be utilized.

Datastream(s) 176 is delivered to mode detector 400. In this embodiment of the invention, a mode detection is utilized. As discussed above, this module provides the capability of distinguishing datastream(s). Datastream(s) might, as discussed, be categorized as traditional vs. spatial, or on the basis of QoS or bit rate requirement. In the embodiment shown, the detector 400 determines that the datastream(s) 176 is destined for spatial mode processing. Responsive to that determination, the parser

404 is configured to parse the datastream(s) 176 into a plurality of the substreams. In the example shown, the two substreams 450-452 are generated by the parser. The substreams each contain a portion of the actual data from the original datastream(s). The function of the stretcher 408, to which the substreams are passed, is to effectively lower the baud rate at which the substreams are transmitted. Figuratively, this is accomplished by clocks 406 and 410 which are coupled to respectively the parser and the stretcher. Clock 410 operates at a rate which is a fraction of the rate of clock 406. The specific fraction is determined by the number of substreams generated by the parser 404. For example, if parser 404 generates from a single datastream(s) two substreams, then each of the substreams will be transmitted at a baud rate which is effectively 1/2 that of the original datastream(s). The stretched substreams are then passed to the router 420. In an alternate embodiment of the invention, the substreams need not be stretched, rather buffered and transmitted at the same baud rate in bursts, if the channel will support the resultant communication rate. The router operating, in the embodiment shown, under the control of the MSC 106 sends the selected substreams 454 and 456 to a single BTS 132 for single-base spatial transmission from each of the spatially separate antenna of that BTS. Those substreams passed through the selector 312 are injected on an appropriate channel within the multiple access protocol. The channel determination is made by the SM\_MA processes/logic 104 that portion of which may be localized in a master/slave control implementation at the MSC. The substreams are then passed to the final transmission stage 316A for transmission to the subscriber unit 150 (see FIG. 6).

FIG. 4B shows hardware/software modules identical to those discussed above in connection with FIG. 4A. The router 420, responsive to a signal from, for example, the MSC 106 has re-routed one of the substreams to BTS 120. That substream 454 is passed to the selector 312B associated with BTS 120. The corresponding substream 456 is presented to selector 312A associated with BTS 132. Under the control of the MSC, each selector is directed to place the substreams on the same MA channel on each of the base stations. The final transmission stages 316A-B of each BTS places the substreams on one antenna of its spatially separate antenna array for transmission to the subscriber 150. The subscriber 150 is in a location in which the signals from base stations 120 and 132 overlap. The composite signals 180 and 178\_M resulting from the transmission of spatially distinct subscriber substreams are received with

spatially separable signatures by the subscriber unit 150 which, as discussed above, is equipped with spatially separate antennas.

The determination to move from a single-base spatial transmission (see FIG. 4A) to multi-base spatial transmission, as shown in FIG. 4B, may be made as a result of any one of the number of distinct determination methods. In the first of these methods, an evaluator portion of either the space/space-time processor 386 or the decoder 388 of the subscriber unit 138 determines that an incoming composite signal cannot be spatially separated into the required number of substreams. In response to this determination, the subscriber unit signals the BTS that a change of spatial configuration is required. This signal is processed by the BTS and may be passed to the MSC 106. In response, the MSC directs the router and selected BTSs, e.g. BTSs 120 and 132, to prepare for and transmit the substreams on an assigned channel. This transition from single-base to multi-base spatial transmission is handled transparently to the subscriber, in order to maintain a consistent QoS throughout the transmission by increasing the spatial separation of the transmitted substreams.

FIG. 4C shows an alternate embodiment of the invention that includes the capability of mode detecting between, for example, traditional and spatial mode datastreams. Datastream(s) 182 is presented to detector 400 via data/control line 108. The datastream(s) might, for example, be a traditional subscriber telephone call or a datastream which has both a low bit rate and QoS requirement. To minimize resources, it may be advantageous for the parser unit 402 to be configurable, so as not to subject all incoming datastream(s) to parsing or, if parsed, so as not to parse into a fixed number of substreams. In the embodiment shown, such capability is implemented. The detector determines that the datastream is traditional mode. That determination may result in the parser avoiding the parsing of the datastream 182. The datastream(s) 182 is passed unparsed to the router 420. The router 420 passes the datastream(s) 182 to the selector 312A of the associated BTS 132. Under the control of the MSC the selector and the final transmissions stage 316A inject the datastream(s) 182 on the appropriate channel of the appropriate multiple access protocol and transmit it via a selected one of the antennas, within the array from which it is received, by subscriber unit 144. That subscriber unit may be a traditional mobile phone lacking any spatial transmission characteristics. Alternately, the subscriber unit may be spatially configurable as well (see FIG. 2A). In this latter

case, BTS 132 injects a control signal to the spatially configurable subscriber unit 144 and, in particular, to the configurable space/space-time processor thereof, indicating that the incoming composite signals are to be treated as a single datastream(s). As will be obvious to those skilled in the art, traditional mode datastreams including, for example, traditional voice telephone calls, may be subject to SM.

As will be obvious to those skilled in the art, each of the above-discussed datastream(s) 178, 176, 182 may include multiple subscriber sessions, time-division multiplexed for example. In this case, all the above-mentioned methodology may be practiced successively on each of the subscriber sessions of a single datastream.

FIG. 4D shows multiple subscriber datastream(s) presented to the detector 400. Specifically datastream(s) 176 and 182 are shown. The first of these datastream(s) is destined for spatial treatment and the second of these datastream(s) 182 is destined for non-spatial treatment. This determination is made by the mode detector 400 based on criteria including, but not limited to, those discussed above. The parsing unit 402 is, in this embodiment of the invention, configurable to concurrently handle multiple subscriber sessions. Upon receipt of control information received either directly from the detector 400 or indirectly from the MSC 106, the parsing module 402 performs the following concurrent operations. The traditional mode datastream(s) 182 is left unparsed and passed directly to the router 420. The spatial mode datastream(s) 176 is parsed by parser 404 into substreams 450-452. These substreams are stretched in stretcher 408, as discussed above, and passed to router 420. The router 420, operating under the control of the MSC, for example, directs each of the datastream(s) and substreams to a single BTS 132 and specifically the associated selector 312A of that BTS.

These substreams generated by the parser are labeled 450-452. The substreams passed by the router are labeled 454-456. This change in reference number is meant to indicate that the initial parsing operation may be accompanied by a lowering of the bit rate or stretching of the clock on which these substreams are transmitted. As will be obvious to those skilled in the art, an alternate methodology for implementing the invention would be to maintain the same the bit rate, provided it was compatible with the bandwidth of the wireless channel on which the transmission



was to take place, and to buffer the data accordingly for transmission in bursts, along with other similarly processed datastream(s)/substreams.

Under the direction of the MSC, for example, the selector 312A and final transmission stage 316A of BTS 132 transmit the substreams 454-456 on a common channel and, depending on the access methodology, may transmit the datastream(s) 182 on the same or another channel. Signal 182 is transmitted from an antenna of BTS 132 to subscriber unit 144. The individual substreams and the associated signals 180, 178\_S of the spatial mode datastream(s) 176 are transmitted to the subscriber unit 150.

FIG. 4E shows an embodiment of the invention identical to that described and discussed above in connection with FIG. 4D. Router 420 re-routes one of the substreams 454-456 of the spatially processed datastream(s) 176 to form a multi-base spatial transmission configuration. That determination to re-route, as discussed above, may originate either from signals received from the corresponding one of the subscriber units which is unable to spatially separate the substreams or alternately may result from a determination by the BTS initially implementing single-base transmission that the bit error rate (BER) is unacceptably high. In this example, subscriber unit 144 continues to receive composite datastream(s) 182 from an antenna on BTS 132. The composite signals received by subscriber 150 now, however, originate from a multi-base configuration. The substream 454 has been re-routed by router 420 to BTS 120, so the composite signals 180, 178\_M originate from BTSs 132,120, respectively.

As will be obvious to those skilled in the art of the reference, in single or a multi-base spatial transmission, discussion to a substream been transmitted from a single antenna, should not be interpreted as a limitation on the teachings of this invention. A single substream in single or multi-base configuration may be transmitted from more than one antenna, if diversity or beam forming transmit processes are implemented in addition to spatial multiplexing.

FIGS. 4F-J show an alternate embodiment of the invention in which the router, as described and discussed above in connection with FIGS. 4A-E, is positioned upstream of the parsing unit rather than downstream of that unit. Consequently, each

of the base stations has associated with it a corresponding parsing unit. FIGS. 4F-G and FIGS. 4I-J show a partial handoff.

FIG. 4F shows MSC 106, BTSs 120 and 132 and the upstream processes/logic 300. Each of the base stations 120 and 132 includes selectors and final transmission stages. Within the upstream processes/logic 300, the detector 400 communicates directly to the router 422. The router, in turn, communicates directly with the parsing units 402A-B associated with BTSs 132 and 120, respectively. Single-base spatial processing of subscriber datastream(s) 176 is shown. The subscriber datastream(s) 176 is received by the detector 400. The detector determines that the mode of the datastream(s) is spatial and that information is passed to the router 422. The router routes the datastream(s) 176 to the appropriate parsing unit 402A. The parsing module 404A of that unit parses the datastream(s) into substreams, e.g. substreams 450-452. Those substreams are passed to stretcher 408A which is coupled to selector 312A. The selector places both the stretched substreams 454-456 on the appropriate channel of the selected MA protocol. Those substreams are transmitted by the final transmit stage 316A of the BTS 132. The signals 178\_S and 180 are transmitted to subscriber unit 150, along with the control information necessary for that subscriber unit to properly process the incoming communication.

FIG. 4G shows a multi-base implementation of the configuration described and discussed above in connection with FIG. 4F. The detector 400 determines that the datastream(s) 454-456 require spatial processing. Additionally, multi-base transmission is determined to be necessary based, for example, on a subscriber unit signal or on the BER detected by a BTS. The router 422, responsive to that determination, routes the datastream to parsing units 402A-B. Each of the parsing modules 404A-B is presented information, not only that the datastream(s) needs to be parsed, but also which substreams are to be discarded at each parsing unit in order to implement a multi-base spatial transmission. In an embodiment of the invention, those in control instructions are generated by the MSC 106. The parsing module 404A generates substream 452. The parsing module 404B generates substream 450. Collectively, substreams 450-452 contain all the information from the original datastream(s) 176 from which they were parsed. The selected substreams are passed to the corresponding stretching modules 408A-B. These stretching modules in turn pass the substreams with a reduced bit rate or in bursts as substreams 456-454 to the

corresponding selectors 312A-B of the associated BTSs 132 and 120. The substreams are placed on the same channels of the multiple access protocol implemented by each BTS. These substreams are transmitted by the corresponding final transmissions stages 316A-B. Signal 180 corresponding to substream 456 is transmitted by at least  
5 an antenna on BTS 132 to subscriber unit 150. Signal 178\_M corresponding to substream 454 is transmitted by at least an antenna of BTS 120 to subscriber unit 150. The inclusion of both single-base and multi-base spatial transmission capabilities in the system allows consistent QoS to be delivered to the subscribers.

FIG. 4H shows an implementation of the current invention in which the  
10 detector 400 includes the capability of distinguishing the mode of the datastream(s), e.g. traditional mode and spatial mode. The detector 400, upon determining that datastream(s) 182 can be processed in traditional mode, passes that information to the router 422. The router passes the datastream(s) 182 to the appropriate parsing unit 402. The parser unit 402A and specifically parser module 404A thereof avoids  
15 parsing the datastream(s) and passes it to the corresponding selector 312A associated with BTS 132. In the manner described and discussed above, the channel and antenna on which that datastream(s) is to be transmitted from BTS 132 is determined by the processes/logic 104, e.g. at the MSC. The associated signal 182 is passed from the BTS to the subscriber unit 144.

FIG. 4I shows the introduction of multiple subscriber datastream(s), i.e. datastream(s) 176 and 182 into the embodiment described and discussed above in connection with FIGS. 4F-H. The detector 400 determines that datastream(s) 182 may be processed in the traditional mode while datastream(s) 176 may be processed in the spatial mode. In this example, both the datastream(s) are routed by router 422  
25 to a single BTS for, respectively, non-spatial and spatial transmission. Stretched datastream(s) 454-456 derived from substreams 450-452 of datastream(s) 176 are presented to the selector associated with BTS 132. Signals 178\_S and 180 are transmitted to subscriber unit 150 on the same channel of the MA protocol implemented by the BTS. Traditional mode datastream(s) may be transmitted on the  
30 same or another channel.

FIG. 4J shows a multi-base spatial transmission of the datastream(s) 176 discussed above in connection with FIG. 4I. A change from single to multi-base

transmission is initiated by the processes/logic 104\_ in response to, for example, a degradation in the bit error rate or to signals from subscriber unit 150 which indicate that a change in spatial configuration is required. This might include changing the antenna selection on the array of a single BTS. The selection might involve a  
5 reduction/increase in the number of transmitting antennas. Alternately, in the example shown, a partial handoff is implemented. To implement the partial handoff, router 422 routes the datastream(s) 176 to both parsing units 402A-B. Control information, indicating which of the substreams generated by the respective parsing unit is to be passed on to the associated BTS, may also be generated. Responsive to  
10 that information, the parsing modules 404A-B each generate only one of the substreams which can be generated from the datastream(s) 176. Each selected substream is stretched by the corresponding stretcher and passed to the corresponding BTS. BTS 132 continues to transmit the traditional mode datastream(s) 182 and the signal corresponding thereto to subscriber unit 144. BTS 132 transmits one of the  
15 stretched substreams 456 in the form of signal 180 to subscriber unit 150. The other of the substreams 454 is passed to the subscriber unit 150 as signal 178\_M from the BTS 120.

As will be obvious to those skilled in the art, the above-mentioned arrangements of detector, router and parsing units represent only some of the possible  
20 configurations of these modules/logic which may be utilized to implement the current invention. In an embodiment of the invention, the wireless network may not support both traditional and spatial transmission together. In that embodiment, the detector may not be required, since all datastream(s) will be handled by spatially transmitting them. In still another embodiment of the invention, multi-base operation may not be  
25 implemented, allowing only for single-base SM. In still another embodiment of the invention, the routing may be accomplished by a single BTS which uses in/out of band channels to wirelessly relay one or more substreams to other BTSs for re-transmissions on the assigned channel.

FIGS. 5A-B show the upstream modules associated with the processing of  
30 datastream(s) and substreams received by the BTSs. That information may be destined for another subscriber unit or for the network 100 (see FIG. 1A).

FIG. 5A shows the base stations 120,132, the upstream processes/logic 300 and the MSC 106. In the example shown, single-base SM is implemented. The subscriber unit 150 is shown transmitting signals 178\_S and 180. These are received by BTS 132 and processed by the associated modules of its configurable SM receiver 5 330 (see FIG. 3). From the decoder 340A, substreams 454-456 are passed to the upstream processes/logic 300. The upstream module includes a router 420 and a combiner 500. The combiner 500 operates in reverse of the manner described and discussed above in connection with the parsing unit 402. The router 420 passes the substreams 454-456 to the combiner 500. The output of the combiner is the 10 subscriber datastream(s) 176.

FIG. 5B shows the modules discussed above in connection with FIG. 5A during the reception of multi-base spatial transmissions from the subscriber unit 150 as well as the single-base transmission from subscriber unit 144. BTS 132 and the associated receiver module 330, have their spatial processor configured to generate a 15 single one of the substreams 456 that can be derived from the composite signals 178\_M and 180 of subscriber unit 150. The other substream 454 is generated by corresponding modules associated with BTS 120. Additionally, on the same/different channel, BTS 132 with the receiver 330 is configured to generate a single datastream(s) 182 from the composite signal 182 transmitted by the subscriber unit 20 144. The datastream(s) 182 of the associated decoder of that BTS, i.e. decoder 340A is passed to the router 420. The combiner is configured to combine substreams 454-456 into datastream 176 and to pass datastream(s) 182 along without combining.

Thus, in an embodiment of the invention, the method and apparatus of the current invention may be used to implement SM\_MA both on the down/up link. As 25 will be obvious to those skilled in the art, SM may be asymmetrically implemented as well, on either the down/up link selectively, without departing from the scope of this invention.

FIG. 6 shows an antenna array of BTS transmitter 132 and the antenna array of the subscriber unit receiver 138 (see FIG. 3). The antenna array of the final 30 transmissions stage 316 includes antennas 134T-136T. The antenna array of the first receiver stage 382 includes antennas 140R-142R. The first receiver stage passes the composite signals 640-642 to the space/space-time processor 386. The output of the

processor is presented to the decoder 388 from which, as output, the substreams 454-456 are generated.

As will be obvious to those skilled in the art, the transmission of data through a wireless medium may involve modulation of an information signal derived from a datastream(s) or substream on a carrier signal. Information may, for example, be contained in the phase and/or amplitude relationship of the signal modulating the carrier. Each specific phase and/or amplitude relationship that is utilized is referred to as a "symbol". The set of all symbols is referred to as the "constellation". The greater the number of symbols in a constellation, the more binary bits of information may be encoded in each symbol in a given constellation. Current communication protocols allow for constellations with over 1024 symbols, each encoding for one of ten bit combinations. Antenna 134T is shown transmitting a symbol 600 within a signal constellation. This corresponds to an associated group of the bits corresponding to the data from a portion of substream 454. Antenna 136T is shown transmitting symbol 606 which corresponds to a different bit sequence derived directly from substream 456. The transmission of substream 454 by antenna 134 results in at least two signals 602-604. The transmission of the symbol 606 by antenna 136 generates at least two signals 608-610. Additional signals are likely in a multi-path environment with numerous scattering objects, such as buildings, etc. For the sake of simplicity, signals 602 and 610 transmitted from respectively antennas 134T-136T are both received by antenna 140R as a single composite signal. The corresponding signals 604 and 608 are received by antenna 142R as a single composite signal. In order for the spatial receiver of the subscriber unit to resolve the composite signals into the estimated subscriber datastream/substreams, the spatial processor 386 must include information about the spatial signatures 620-622 of the transmissions from each of the antennas 134-136. These spatial signatures may be determined using either blind and or non-blind training methods in the manner described and discussed above. By placing the decoder 388 downstream from the space/space-time processor 386, the appropriate symbols may then be derived from the substream and converted into a corresponding binary sequence from which the corresponding portions of the substreams 454-456 may be generated.

As will be obvious to those skilled in the art, any of a number of other modulation techniques may be used to implement the current invention including:

continuous phase modulation (CPM), continuous frequency modulation (CFM), phase shift keying (PSK), offset phase shift keying, amplitude shift keying (ASK), pulse position modulation (PPM), pulse width modulation (PWM), etc., without departing from the scope of this invention.

5           FIGS. 7A-B show an embodiment of the invention in which the spatial processor 386 is configured for both traditional and spatial mode signal reception. Additionally, in the spatial mode, the spatial processor is configurable to generate a variable number of substreams to correspond to the number transmitted. Spatial processor 386 and the decoder 388 are shown. The spatial processor 386 includes:  
10 first fabric switch 700, first configurable logic 702, second fabric switch 730, second configurable logic 732, an evaluator 740, and a controller 746.

The spatial processor 386 is coupled via the receive processes 384 to the receiver first stage 380 of the subscriber unit, as discussed above in connection with FIG. 3. Similar design applies to the spatial processor 338 in the BTS (see FIG. 3).  
15 The composite signal(s) detected by the first stage receiver is passed to the fabric switch 700 of the spatial processor. Responsive to signals generated by the control unit 746, the first fabric switch passes the composite signal/signals to one or more of the sub-modules within first logic unit 702. In the embodiment shown, a sub-module includes a multiplier 704 and a weight register 712. The multiplier generates an  
20 output signal which is a product of the weight stored in weight register 712 multiplied by the incoming composite signal. The weights in this register and the register of other sub-modules may be derived using non-blind or blind training methods as discussed above. In the example shown in FIG. 7A, a composite signal 750 is presented to fabric switch 700. This switch has been configured utilizing in/out of  
25 band control signals to process a single composite signal. The output of the multiplier is presented to the second fabric switch 730. This fabric switch also is configurable by means of the control unit 746. The fabric switch 730 presents the signals from the first logic module in variable configurations to one or more of the summers, e.g. summer 734 which is part of the second configurable logic in this embodiment of the  
30 invention. Because a single composite signal is being processed in the embodiment shown in FIG. 7A, only one summer is utilized. The input to that summer is the output of the multiplier 704 and the zero input provided by the control unit 746. The output of the summer 734 is passed to the evaluator 740 (optional). The evaluator

determines when signals that are spatially transmitted are not separable, and if separable, the quality of each link. The quality of each link may be evaluated using, for example, Signal to Interference Noise Ratio (SINR). The resultant traditional mode datastream(s) 182 is passed through the decoder. In the decoder the conversion  
5 from symbols to associated bit sequences is implemented. As shown above in FIG. 3, the output of the decoder is passed to an associated combiner. The configuration of the configurable spatial processor under the control of control unit 746 takes place as a result of in/out of band control signals. These signals may be generated during call setup or during an actual call session by SM\_MA processes/logic 104.

10 In FIG. 7B, the configurable nature of the spatial processor is evident by comparison to FIG. 7A. Composite signals 640-642 are presented to the first fabric switch 700. Responsive to signals from the control unit 746, the first fabric switch generates output signals for each of the composite input signals. Composite signal 640 is passed to a first pair of logic sub-modules within the first logic unit 702.  
15 Composite signal 642 is passed to a second pair of logic sub-modules within the first logic unit 702. The first pair of logic sub-modules include: multiplier 704 together with associated weight register 712, and multiplier 706 together with associated weight register 714. The second pair of logic sub-modules include: multiplier 708 together with associated weight register 716, and multiplier 710 together with  
20 associated weight register 718. Multipliers 704-706 receive as inputs the composite signal 640. Multipliers 708-710 receive as inputs the composite signal 642. The weight registers may contain weights obtained during transmission of a training sequence which allow training sequences to be separated. These are multiplied by the corresponding composite signal inputs and the four products are cross-coupled to  
25 summers 734-736 of the second logic unit 732 by the second fabric switch. The output of summers 734-736 is, respectively, the estimated substreams 454-456. In the embodiment shown, these are passed through an evaluator 740 to the decoder 388. Subsequently, the estimated substreams are combined into the original datastream 176 (not shown). The decoder 388 performs the above-mentioned function of mapping  
30 the summer output into symbols and from the symbols, into the appropriate binary sequences. In an alternate embodiment of the invention, the evaluator may be placed downstream of the decoder and perform a similar function at that location.



The evaluator monitors the estimated substreams to determine if they are appropriately separated, and if separable, the quality of the link(s). This determination might, for example, be made during the transmission of a training sequence. When the evaluator determines it is no longer possible to spatially separate the corresponding substreams, that determination may be passed to the upstream processes/logic 104, e.g. the MSC 106 (see FIG. 1). This results in an alteration of the spatial configuration of the transmission. A change in spatial transmission may be implemented in any number of ways. These include: a change in the antenna selection and/or number at a single base, a change from traditional to spatial mode broadcasting at a single base, a change from single-base to multi-base transmission. Similarly, when the evaluator determines that the substreams are separable, it may pass on the link quality parameters to the upstream processes/logic 104, e.g. the MSC 106. This can help the BTS/MS/CO side of the processes/logic 104\_ choose the modulation rate (bits per symbol) of each substream, and carry out parsing accordingly.

FIGS. 7C-D show an embodiment of space-time processor. To the capabilities of the above-discussed spatial processor is added the ability to remove the interference in the composite signal caused by the delayed versions of the composite signal over time. To account for these perturbations, one or more delay elements may be introduced into the signal paths in the first logic unit to account for these effects. An exploded view of an embodiment of a time logic sub-module is shown in FIG. 7D. In the embodiment shown, each time sub-module is coupled to the output of a corresponding multiplier in the first logic unit. Time sub-modules 720-726 are coupled to the outputs of multipliers 704-710, respectively. Each time module may consist of a plurality of delay elements. In the exploded view, a sub-module includes delay modules 760-762; multipliers 770-772 together with associated weight registers 780-782, as well as a summer 790. The output of multiplier 704 is an input both to delay module 760 and summer 790. The output of delay module 760 is an input both to delay module 762 and to multiplier 770. The output of delay module 762 is an input to multiplier 772. The outputs of the multipliers provide additional inputs to the summer 790. The output of the summer is presented to the second fabric switch 730. Each time module may include additional multipliers with associative delay units and weight registers. As was the case in FIGS. 7A-B, the space-time processor in FIGS. 7C-D is configurable. FIG. 7C shows the processor configured for a single input

composite signal 750. FIG. 7D shows the space-time processor configured for two composite input signals 640-642.

The spatial/space-time processor of FIGS. 7A-D is configurable; e.g. capable of processing a variable number of composite signals and outputting a corresponding number of estimated subscriber substreams. In another embodiment of the invention, the spatial/space-time processor is not configurable; accepting instead a fixed number of substreams and outputting a corresponding fixed number of estimated subscriber substreams.

As will be obvious to those skilled in the art, any of a number of other processing techniques may be used to implement the current invention, including: space-time, space- frequency, space- code, etc. In turn, these may further utilize any, or a combination of techniques including, but not limited to: linear or non-linear processing, Maximum Likelihood (ML) techniques, Iterative decoding/interference canceling, Multi-user detection (MUD) techniques, etc., without departing from the scope of this invention.

FIG. 8 shows a datastream interspersed with the training sequences consistent with a non-blind embodiment of the current invention. Training sequences 800-802 and data sequences 850-852 are shown. Suitable training sequences include orthogonal Walsh codes transmitted by the spatially separate antennas. The spatial/space-time processor of the receiver attempts to generate weights which separate the known Walsh code sequences. Those weights are then used in processing the subsequent datastream(s)/substreams. In an embodiment of the invention, the training sequences are inserted into the datastream at frequency/duty cycle, which depend on the mobility of the subscriber unit. In another embodiment of the invention, the training sequences vary in duration and are constant in frequency. The training sequences may be transmitted in/out of band. As the mobility of a subscriber increases, the frequency/duty cycle of the training sequences may be increased. The mobility of the subscriber unit can, as discussed above, be detected by Doppler shift/spread detected by the mobility detector 334 (see FIG. 3) on the receive side of the base station, for example. When the subscriber unit is fixed, training may only be performed at, or before, call setup or at a relatively low frequency/duty cycle during a call/data session. In still other embodiments of the invention, no training sequences

would be inserted into the datastream(s)/substreams, instead relying on blind training techniques discussed above.

FIGS. 9A-B to 12A-B show various access methodologies utilized to provide multiple-access spatial multiplexing in accordance with the current invention. The figures labeled with "A" show the transmit portion of each access method while the figures labeled with "B" show the receive side. FIGS. 9A-B show SM time-division multiple access (TDMA). FIGS. 10A-B show SM frequency-division multiple access (FDMA). FIGS. 11A-B show SM code-division multiple access (CDMA). FIGS. 12 A-B show SM space-division multiple access (SDMA). The modules disclosed herein on the upstream side, as well as the subscriber side, may be implemented in hardware/software. They may be implemented on a single chip, e.g. DSP or ASIC. The modules disclosed on the upstream side may be located in the BTS or further upstream, e.g. the MSC/CO. On the subscriber side the modules may be implemented in a single unit.

FIG. 9A shows a slot selector 900, a transmit processor module 314A (optional), and a final transmit stage 316A. In the embodiment shown, these are part of the above-discussed BTS 132 (see FIG. 1A). Each of these modules is coupled to the control elements shown in FIG. 3, i.e. training module 328, mobility detector 334, memory 322, processor 324, and clock 326. These are coupled via signal/control line 108 to the MSC 106. The mobility detector is, in an embodiment of the invention shown in FIG. 3, part of the receive side of the BTS. It is shown in FIG. 9A for purposes of clarity, since it interacts with the training module 328 and CPU 324 to detect and generate training sequences responsive to the mobility of the subscriber unit. Subscriber datastream 182 and substreams 454-456 derived from subscriber datastream 176 (see FIGS. 4A-J) are shown as inputs to the slot selector 900. In TDMA each subscriber session is allocated a specific time segment in which to be transmitted. Time segments are assigned in round-robin fashion. In the traditional public switched telephone network (PSTN), there are twenty-four time slots (a.k.a. channels/D0). The slot selector 900, under the direct/indirect control of processes/logic 104 and implemented at, e.g. the MSC 106, assigns the related substreams 454-456 to identical channels (TDMA slots) within the separate TDMA datastream(s) 902-904, which are output by the slot selector. The traditional mode datastream 182 is assigned to a separate channel/slot within TDMA datastream 904.

Each of the TDMA datastream(s) 902-904 is, in an embodiment of the invention, provided as an input to an optional transmit processing module 314A. That module may implement any one of a number of well known prior art techniques for improving signal quality in a wireless network including: diversity, space coding, space-time coding, space-frequency coding, beam forming, interference canceling, etc.

The transmit processor 314A (optional) includes, in the embodiment shown, diversity processing, space-time coding and beam-forming. Beam-forming exploits channel knowledge to direct transmissions to the location of the corresponding subscriber. Diversity may be implemented in: frequency, time, space, polarization, space/space-time, etc. The outputs of the optional transmit processor 314A are provided as inputs to the final transmit stage 316A. That stage includes encoder modulators 924-926, operating off a common carrier 914 for processing each of the TDMA datastream(s) 902-904. These modulated datastream(s) are passed to respective RF stages 934-936 and associated antennas 134T-136T for spatially separate transmission of the individual substreams that they contain, e.g. 454-456. Additional antenna arrays 940-942, RF stages 930-932, encoder/modulator stages 920-922 are used to implement any of the optional transmit processes.

FIG. 9B shows the receive side of a subscriber unit 150 enabled for spatial multiplexing utilizing TDMA access. That unit includes: first receiver stage 382A, receive processor 384A (optional), spatial/space-time processor 386, decoder 388, combiner 390, I/O module 392, TDMA slot selector 978, processor 374, carrier recovery module 376, memory 372, and training module 378. The first receiver stage includes antennas 140R-142R which are coupled via, respectively, RF stages 952-950 to demodulator/sampling modules 962-960. The demodulator/sampling units operate off a common carrier 970. An additional antenna array 946, RF stage 954, demodulator/sampling module 964, and carrier generator 972 are utilized by the receive processor 384A to implement: diversity processing, space-time decoding, beam-forming, etc.

In operation, the carrier recovery module 376 synchronizes the carriers 970-972 to the carrier frequency of the incoming composite signals 990-992. The TDM slot selector 978 accepts a channel assignment from the BTS(s) and synchronizes the

receive processes accordingly. The composite signals from each antenna are demodulated and sampled by the corresponding one of the demodulator/sampling modules 964-960. The outputs of these modules provide inputs to the receive processor 384A. The receive processor implements signal processing techniques which may complement one or more of the optional processes discussed above for the transmit side (see FIG. 9A). Each composite signal output by the receive processes/logic 384A provides inputs to the spatial/space-time processor 386 (see FIGS. 7A-D). That processor, using parameters/weights derived from the above-discussed blind/non-blind training techniques, separates the composite signals into the appropriate number of estimated subscriber substreams, e.g. 996-998. In configurable embodiments of the spatial/space-time processor, information received from the BTS(s) at the start of, or during, a call session configures the processor to generate a number of substreams that correspond to the actual number of substreams transmitted. Next, the estimated subscriber substreams are provided as inputs to a similarly configured decoder 388. The decoder maps symbols utilized during the transmission of the substreams/datastream(s) into their binary equivalent. The decoder outputs the estimated subscriber substreams 454-456 to the combiner 390. The combiner reverses the operation performed on the transmit side by the parser, generating thereby an estimated subscriber datastream 176. This datastream is provided to the I/O module 392 for subsequent presentation to the subscriber as for example, an audio signal, a video signal, a data file, etc.

FIGS. 10A-B show a BTS implementing SM frequency-division multiple access (FDMA). In FDMA, each subscriber session, whether traditional or spatially processed, is provided with a single frequency slot within the total bandwidth available for transmission. The BTS includes: a frequency slot selector 1000, a transmit processor module 314B (optional), and a final transmit stage 316B. In the embodiment shown, these are part of the above-discussed BTS 132 (see FIG. 1A). Each of these modules is coupled to the control elements shown in FIG. 3, i.e. training module 328, mobility detector 334, memory 322, processor 324, and clock 326. These are coupled via signal/control line 108 to the MSC 106. Subscriber datastream 182 and substreams 454-456 derived from subscriber datastream 176 (see FIGS. 4A-J) are shown as inputs to the frequency slot selector 900. The selector 1000, under the direct or indirect control of the MSC 106, selects the appropriate frequency slot for

the datastream(s)/substreams. This is represented in FIG. 10A by a final transmit stage which includes encoder/modulator clusters (1020-1022), (1024-1026), and (1028-1030), each of which modulates about a unique center frequency as determined by respective associated carriers 1010-1014. Intermediate the frequency selector 5 1000 and the final transmit stage 316B, is an optional transmit processing unit 314B which may impose on the datastream(s)/substreams additional signal processing utilizing antenna arrays 1040-1042 in conjunction with antennas 134T-136T, as discussed above in connection with FIG. 9A.

Within the final transmit stage two spatially separate antennas 134T-136T are 10 shown. These are coupled via, respectively, RF stages 1034-1036 and summers (1002-1004),(1006-1008), to separate outputs of each of three encoder/modulator clusters. Each encoder/modulator cluster operates about a distinct center frequency. Each cluster contains a number of encoder/modulator outputs at least equivalent to the number of spatially separate antennas in the final transmit stage. Since there are two 15 antennas in the example shown, each cluster contains at least encoding/modulating capability for processing two distinct substreams and for outputting each separately onto a corresponding one of the antennas for spatially separate transmission. The traditional mode datastream 182 is assigned to the first cluster with a center frequency determined by carrier 1010. That datastream is output via summer 1006 on antenna 20 136T. Each of the substreams 454-456, parsed from a common datastream 176 (see FIGS. 4A-J) is passed to a single cluster for spatially separate transmission on a single center frequency corresponding, in the example shown, to the center frequency determined by carrier 1012. The modules disclosed herein may be implemented in the BTS or further upstream, e.g. the mobile switching center. They may be 25 implemented as hardware or software. They may be implemented on a single chip, e.g. DSP or ASIC.

FIG. 10B shows a subscriber unit 150 enabled for spatial multiplexing utilizing FDMA access methodology. That unit includes: first receiver stage 382B, receive processor 384B (optional), spatial/space-time processor 386, decoder 388, 30 combiner 390, I/O module 392, frequency selector 1078, processor 374, carrier recovery module 376, memory 372, and training module 378. The first receiver stage includes antennas 140R-142R, which are coupled via RF stages 1052-1050, respectively, to demodulator/sampling modules 1062-1060. The

demodulator/sampling units operate off a common frequency synthesizer 1070. Additional antenna array 1046, RF unit 1054, demodulator/sampling unit 1064, and frequency synthesizer 1072 are shown. Optionally, these may be utilized by receive processing unit 384B to implement any of the receive processes discussed above in  
5 connection with FIG. 9B.

In operation, the carrier recovery module 376 synchronizes the carriers 1070-1072 to the carrier frequency assigned by the BTS for the subscriber session, i.e. the carrier frequency at which the composite signals 1090-1092 are transmitted. The composite signals from each antenna are demodulated and sampled by the  
10 corresponding one of the demodulator/sampling modules 1064-1060. The outputs of these modules provide inputs to the receive processor/logic 384B. The receive processor implements signal processing techniques which may complement one or more of those discussed on the transmit side (see FIG. 10A). Each composite signal output by the receive processor/logic 384B provides inputs to the spatial/space-time  
15 processor 386 (see FIGS. 7A-D). That processor, using parameters/weights derived using the above-discussed blind/non-blind training techniques, separates the composite signals into the appropriate number of estimated subscriber substreams/datastream(s), e.g. 1096-1098. In configurable embodiments of the spatial/space-time processor, information received from the base stations at the start  
20 of, or during a call session, configures the processor to generate a number of substreams/datastream(s) which correspond to the actual number of substreams/datastream(s) transmitted. Next, the estimated subscriber substreams/datastream(s) are provided as inputs to a similarly configured decoder 388. The decoder maps symbols utilized during the transmission of the  
25 substreams/datastream(s) into their binary equivalent. The decoder outputs the estimated subscriber substreams in their binary equivalent 454-456 to the combiner 390. The combiner reverses the operation performed on the transmit side by the parser, generating thereby an estimated subscriber datastream 176. This datastream is provided to the I/O module 392 for subsequent presentment to the subscriber as for  
30 example, an audio signal, a video signal, a data file, etc. As will be obvious to those skilled in the art, the subscriber unit may be configured to receive more than one channel concurrently.

FIGS. 11A-B show a BTS implementing SM code-division multiple access (CDMA). In CDMA, each subscriber session, whether traditional (unparsed) or spatially processed (parsed), is provided with a distinct code sequence. The datastream/substreams are modulated (spread) onto the distinct code sequence/key code ( $K_n$ ), and the spread signal is, in turn, modulated onto a common carrier. This has the effect of spreading each session across the entire transmission bandwidth. The BTS includes a key/code selector 1100, a transmit processor module 314C (optional), and a final transmit stage 316C. In the embodiment shown, these are part of the above-discussed BTS 132 (see FIG. 1A). Each of these modules is coupled to the control elements shown in FIG. 3, i.e. training module 328, mobility detector 334, memory 322, processor 324, and clock 326. These are coupled via signal/control line 108 to the MSC 106. Shown here for ease of explanation, the mobility detector, as discussed above, is actually implemented on the receive side of the BTS and interacts with the training module 328 to inject training sequences into the SM\_CDMA transmissions.

Subscriber datastream 182 and substreams 454-456 derived from subscriber datastream 176 (see FIGS. 4A-J) are shown as inputs to the key/code selector 1100. The selector 1100, under the direct or indirect control of the MSC 106, selects the appropriate key/code sequence for the datastream(s)/substreams. This is represented in FIG. 11A by a final transmit stage which includes spreader and encoder/modulator clusters, (1110-1111,1120-1121), (1112-1113,1122-1123), and (1114-1115,1124-1125) each of which modulates over a unique key code, respectively 1116-1118, and all of which modulate on a common carrier 1126. Intermediate the code/key selector 1100 and the final transmit stage 316C is the optional transmit processing unit 314C, which may impose on the datastream(s)/substreams additional signal processing, such as that described and discussed above in connection with FIG. 9A.

Within the final transmit stage, two spatially separate antennas 134T-136T are shown, along with an optional antenna array 1140-1142 associated with transmit processing. These are coupled via, respectively, RF stages 1134-1136 and summers (1102-1104),(1106-1108) to separate outputs of each of three spreader encoder/modulator clusters. Each spreader encoder/modulator cluster operates about a distinct key code. Each cluster contains a number of encoder/modulator outputs at least equivalent to the number of spatially separate antennas in the final transmit



stage. Since there are two antennas in the example shown, each cluster contains at least encoding/modulating capability for processing two distinct substreams and for outputting each separately onto a corresponding one of the antennas for spatially separate transmission. The traditional mode datastream 182 is assigned to the second  
5 cluster with the key code 1117. That datastream is output via summer 1104 on antenna 134T. Each of the substreams 454-456, parsed from a common datastream 176 (see FIGS. 4A-J), is passed to a single cluster for spatially separate transmission with a single key code 1116.

FIG. 11B shows a subscriber unit 150 enabled for spatial multiplexing  
10 utilizing CDMA access methodology. That unit includes: first receiver stage 382C, receive processor 384C (optional), spatial/space-time processor 386, decoder 388, combiner 390, I/O module 392, key/code selector 1182, processor 374, carrier recovery module 376, memory 372, and training module 378. The first receiver stage includes antennas 140R-142R, which are coupled via, respectively, RF stages 1152-  
15 1150 to demodulator/sampling modules 1168-1166. Demodulator/sampling modules 1168-1166 operate off a carrier 1172. The output of these is passed to de-spreaders 1162-1160, respectively, which operate off of key code 1176, assigned by the key/code selector 1182 on the basis of control information passed between subscriber unit and base station. Carrier recovery and synchronization may be handled by carrier  
20 recovery module 376, operating in conjunction with carrier generator 1172. Additionally, first receiver stage 382C includes optional antenna array 1146, RF stage 1154, demodulator/sampling unit 1170, carrier generator 1174, de-spreader 1164, and key/code generator 1178. These may be utilized in conjunction with the optional receive processor 384C in the manner discussed above in FIGS. 9B and 10B.

25 In operation, the carrier recovery module 376 synchronizes the carriers 1172-1174 to the carrier assigned by the BTS for the subscriber session, i.e. the carrier at which the composite signals 1190-1192 were transmitted. The composite signals from each antenna are then demodulated and sampled by the corresponding one of the demodulator/sampling modules 1168-1166. Respectively, the outputs of these  
30 modules provide inputs to de-spreaders 1162-1160, where they are de-spread using the key code 1176 assigned for the session. The outputs of the de-spreaders provide inputs to the optional receive processor 384C. The receive processor may implement signal processing techniques which complement one or more of those discussed on

the transmit side (see FIG. 11A). Each composite signal output by the receive processes/logic 384C provides inputs to the spatial/space-time processor 386 (see FIGS. 7A-D). That processor, using parameters/weights derived using the above-discussed blind/non-blind training techniques, separates the composite signals into the appropriate number of estimated subscriber substreams/datastream(s), e.g. 1196-1198. In configurable embodiments of the spatial/space-time processor, information received from the base stations at the start of, or during, a call session configures the processor to generate a number of substreams/datastream(s) which correspond to the actual number of substreams/datastream(s) transmitted. Next, the estimated subscriber substreams/datastream(s) are provided as inputs to a similarly configured decoder 388. The decoder maps symbols utilized during the transmission of the substreams/datastream(s) into their binary equivalent. The decoder outputs the estimated subscriber substreams 454-456 in their binary equivalent to the combiner 390. The combiner reverses the operation performed on the transmit side by the parser, generating thereby an estimated subscriber datastream 176. This datastream is provided to the I/O module 392 for subsequent presentment to the subscriber as, for example, an audio signal, a video signal, a data file, etc. As will be obvious to those skilled in the art, the subscriber unit may be configured to receive more than one channel concurrently.

FIGS. 12A-B show a BTS implementing space-division multiple access (SDMA). In SDMA, each subscriber session, whether traditional (unparsed) or spatially processed (parsed), is transmitted as a shaped beam; a high gain portion of which is electronically directed using beam forming toward a known subscriber, at a known location, within a cell. This has the effect of allowing channel re-use within a single cell by beam forming each subscriber session to a separate segment of a cell.

The BTS includes a beam steering selector 1200, a transmit processor module 314D (optional), and a final transmit stage 316D. In the embodiment shown, these are a part of the above-discussed BTS 132 (see FIG. 1A). Each of these modules is coupled to the control elements shown in FIG. 3, i.e. training module 328, mobility detector 334, memory 322, processor 324, and clock 326. These are coupled via signal/control line 108 to the MSC 106. Subscriber datastream 182 and substreams 454-456, derived from subscriber datastream 176 (See FIGS. 4A-J), are shown as inputs to the beam steering selector 1200. The selector 1200, under the direct/indirect

control of the MSC 106, selects the appropriate direction in which beam steering is to be carried out for each subscriber session and its associated datastream/substreams. Intermediate the beam steering selector 1200 and the final transmit stage 316D is the optional transmit processing unit 314D, which may impose on the  
5 datastream(s)/substreams additional signal processing, such as that described and discussed above in connection with FIG. 9A, with the exception of beam forming.

Within the final transmit stage, two pairs of spatially separate antennas 134TA/B-136TA/B are shown. Additionally, antenna array 1240 associated with transmit processes 314D is shown. The two pairs of antennas are coupled via,  
10 respectively, RF stages 1234,1230,1236,1232 to beam steering module 1202. The beam steering module accepts as inputs the separately encoded and modulated outputs from encoder modulators 1220-1226, each of which operated on a common carrier 1210, and each of which handles a different substream/datastream. The steering of datastream 182 to subscriber 144 (see FIG. 1B), and of substreams 454-456 to  
15 subscriber 150, is accomplished by beam steering unit 1202. That unit, operating with a known location/channel for each subscriber, steers the output beams from the antennas so that they interfere in a manner which maximizes the gain appropriately. At the location of subscriber 144, beam steering results in the composite signal corresponding to datastream 182 reaching a relative maximum, while the gain of the  
20 composite signals corresponding to the substreams 454-456 at that location is minimized. Beam steering also accomplishes the opposite effect at the location of subscriber unit 150.

FIG. 12B shows a subscriber unit 150 enabled for spatial multiplexing utilizing SDMA access methodology. That unit includes: first receiver stage 382D,  
25 receive processor 384D (optional), spatial/space-time processor 386, decoder 388, combiner 390, I/O module 392, processor 374, carrier recovery module 376, memory 372, and training module 378. The first receiver stage includes antennas 140R-142R, which are respectively coupled via RF stages 1252-1250 to demodulator/sampling modules 1262-1260. Demodulator/sampling modules 1262-1260 operate off of a  
30 common carrier 1270. Carrier recovery and synchronization may be handled by carrier recovery module 376 operating in conjunction with carrier generator 1270. Additionally, the first receiver stage may also include: an antenna array 1246, coupled via RF stage 1254 to a demodulator/sampler 1264, and associated carrier module

1272. These operate under the control of receive processes 384D to implement any of the receive processes discussed above in connection with FIG. 9B, 10B and 11B.

In operation, the carrier recovery module 376 synchronizes the carriers 1270-1272 to the carrier at which beam forming is conducted by the BTS(s). The composite signals from each antenna are then demodulated and sampled by the  
5 corresponding one of the demodulator/sampling modules 1268-1266. The outputs of these modules provide inputs to the receive processor 384D. Each composite signal output by the receive processes/logic 384B provides inputs to the spatial/space-time processor 386 (see FIGS. 7A-D). That processor, using parameters/weights derived  
10 using the above-discussed blind/non-blind training techniques, separates the composite signals into the appropriate number of estimated subscriber substreams/datastream(s), e.g. 1296-1298. In configurable embodiments of the spatial/space-time processor, information received from the base stations at the start of, or during, a call session configures the processor to generate a number of  
15 substreams/datastream(s) that correspond to the actual number of substreams/datastream(s) transmitted. Next, the estimated subscriber substreams/datastream(s) are provided as inputs to a similarly configured decoder 388. The decoder maps symbols utilized during the transmission of the substreams/datastream(s) into their binary equivalent. The decoder outputs the  
20 estimated subscriber substreams in their binary equivalent 454-456 to the combiner 390. The combiner reverses the operation performed on the transmit side by the parser, generating thereby an estimated subscriber datastream 176. This datastream is provided to the I/O module 392 for subsequent presentment to the subscriber as, for example, an audio signal, a video signal, a data file, etc. As will be obvious to those  
25 skilled in the art, the subscriber unit may be configured to receive more than one channel concurrently.

Although FIGS. 9-12 show four distinct multiple access methods, it will be obvious to those skilled in the art that each of these may be combined with one or more of the others without departing from the scope of this invention, as well as with  
30 such multiple access methods as: orthogonal frequency division multiple access (OFDMA), wavelength division multiple access (WDMA), wavelet division multiple access, or any other orthogonal division multiple access/quasi-orthogonal division multiple access (ODMA) techniques.

FIGS. 13A-B show the process flow for transmit and receive processing/logic 104\_ associated with an embodiment of the current invention. These processes/logic may be carried out across multiple datastreams, either in parallel, serially, or both. Processing begins at process block 1300 in which the next datastream is detected.

5 Control then passes to decision process 1302. In decision process 1302 a determination is made as to the mode of the datastream. As discussed above, the mode determination may distinguish traditional/spatial, quality of service, bit rate, etc. as well as various combinations thereof. If a determination is made that the mode is traditional, control passes to process 1304. In process 1304 a routing determination is

10 made for the datastream. The routing decision may involve the MSC directing the datastream to an appropriate one of the base stations for transmission. Control then passes to process 1306. In process 1306, the datastream is placed on the appropriate channel within the access protocol implemented on the wireless network. Channel assignment may also be made by the MSC. Control then passes to process 1308 in

15 which the subscriber datastream is transmitted. Next, in decision process 1310, a determination is made as to whether any handoff from one BTS to another is appropriate. If this determination is in the affirmative, control returns to process 1304 for re-routing of the datastream. Alternately, if a negative determination is made in

20 process 1310 that the subscriber is fixed, or still within the cell associated with the transmitting BTS, then control returns to process 1300 for the processing of the next datastream.

If, alternately, in decision process 1302 the mode of the next datastream is determined to be spatial, control passes to process 1320. In process 1320 the datastream is split into a configurable number of substreams. Control is then passed

25 to process 1322. In process 1322 the individual substreams are routed and to one or more base stations for transmission to the subscriber. Control then passes to process 1324. In process 1324, under the direct or indirect control the MSC (see FIG. 1A), the access channel on which to transmit the substreams is selected. That information is communicated to the BTS(s) which are involved in the transmission of the

30 substreams. Control then passes to decision process 1326. In decision process 1326 a determination is made as to whether the intended subscriber is mobile or fixed. If a negative determination is reached, i.e. that the subscriber is fixed, control passes to process 1328. In process 1328, a training sequence either at set-up or during a call

session is generated provided non-blind training protocols are being utilized. The receipt of these training sequences by the subscriber unit allows that unit to derive appropriate weight parameters in the first logic unit of the spatial/space-time processor for separating the composite signals into individual estimated substreams (see FIGS. 7A-D). Alternately, if in decision process 1326 an affirmative determination is reached, i.e. that the subscriber is mobile, then control is passed to process 1330. In process 1330, the frequency or duration of the training sequences inserted into the datastream is increased appropriately. This allows the subscriber unit to continually re-train its spatial/space-time parameters to account for possible changes in the spatial environment brought about by its motion. Control is then passed to process 1332. In process 1332 a determination is made as to the number of substreams that are to be transmitted. The subscriber unit is then signaled as to the number of substreams for which it should configure its spatial/space-time processor and other modules. Control is then passed to process 1334. In process 1334 the selected BTS(s) transmit the selected substreams to the corresponding subscriber unit. Control is then passed to decision process 1336.

In decision process 1336, a decision is made as to whether signal separation at the subscriber unit is adequate. As discussed above, this determination may, for example, be based on feedback from the subscriber unit by monitoring the received signal stream from the subscriber unit, or by monitoring bit error rate (BER) at the transmitting BTS(s). Numerous other methods will be evident to those skilled in the art for making this determination. If this decision is in the negative, i.e. that the subscriber unit is unable to separate the substreams, control returns to process 1320. The process 1320 may now parse the data stream into lesser number of substreams than before, or may do parsing as before, then pass the control to process 1322 for re-routing of the datastream's substreams. Re-routing might, for example, include a change of spatial configuration on a single BTS, or a changeover from single-base to multi-base transmission, as discussed above in connection with FIGS. 4A-J. Alternately, if in decision process 1336 an affirmative determination is reached that the subscriber unit is able to separate the substreams, control passes to decision process 1338. In decision process 1338 a determination is made as to whether a handoff is required. This may result in a partial or full handoff. If that determination is in the negative, e.g. the subscriber unit is fixed, or still within the cell and is capable

of separating the substreams, then control returns to process 1300 for the interception of the next datastream. Alternately, if that decision is in the affirmative, control returns to process 1320. The process 1320 parses the datastreams as before, and passes the control to process 1322 for re-routing of the substreams to one or more  
5 base stations.

FIG. 13B shows the receive processes/logic of a subscriber unit associated with an embodiment of the invention. Processing begins at process 1350, in which the next datastream is detected. Control is then passed to decision process 1352. In decision process 1352, a control signal from the BTS is received indicating the  
10 mode of the transmitted signal, e.g. traditional/spatial, and in the latter case, the number of substreams to be generated from the composite signals received. If the composite signals are to be treated as carrying a traditional datastream, control is passed to process 1354. In process 1354 the appropriate channel on which to receive the composite signal is assigned. Channel assignment may occur: during call setup,  
15 during a change in spatial configuration, or during a change from single-base to multi-base transmission, for example. Control is then passed to process 1356. In process 1356 the composite signals are received and appropriately processed by the associated modules of the subscriber unit (see FIG. 3). Control is then passed to decision process 1358. In decision process 1358, any training sequences and update of signal processing parameters that may be required are performed. Control is then passed to  
20 decision process 1360 for a determination as to whether signal quality and/or strength is adequate. If an affirmative determination is reached, e.g. that quality and/or strength is adequate, then control returns to process 1350 for the processing of the next datastream. Alternately, if a negative determination is reached, then control is  
25 passed to process 1362. In process 1362 signaling of the BTS(s) that signal strength or quality is not acceptable is accomplished. In an embodiment of the invention, the subscriber unit signals the BTS that signal strength is no longer suitable for reception, or that signal separation, in the case of spatial transmissions, is no longer adequate. Control then returns to process 1350 for the processing of the next datastream.

30 If, alternately, in decision process 1352 the control signal from the BTS indicates that the mode of the incoming composite signals is spatial, control is passed to process 1370. In process 1370, control information received by the subscriber unit indicates the number of substreams for which the spatial processor, and other modules

of the receive portion of the subscriber unit, are to be configured. Control is then passed to process 1372. In process 1372 access parameters, e.g. channel, for the transmission from the BTS(s) to the subscriber unit are passed to the subscriber unit. Control then passes to process 1374. In process 1374 the composite signals are received and processed into corresponding estimated subscriber substreams. Control then passes to decision process 1376. In decision process 1376 a determination is made as to whether any training sequence is present in the datastream. This embodiment of the invention therefore implements non-blind training. Other embodiments of the invention implementing blind training methods need not implement this particular act. If, in decision process 1376 a negative determination is reached, i.e. that no training sequences are present, control returns to process 1350. Alternately, if in decision process 1376 an affirmative determination is reached, i.e. that a training sequence is present, then control is passed to process 1378. In process 1378, evaluation of the training sequence is performed and new weights registered within the spatial/space-time processor for separating the training sequences. Control is then passed to decision process 1380 for evaluation of the training sequences, then passed to decision process 1382 for a determination of whether the training sequences can be separated adequately. If an affirmative decision is reached, then control returns to decision process 1350. Alternately, if the separation is not adequate, then control passes to process 1384. In process 1384, a control signal is sent to the BTS indicating that a change in spatial configuration is required. The BTS(s) might respond by changing spatial configuration from single to multi-base, by changing the number or spatial configuration of the antennas utilized at a single base, by changing a channel, etc. Control then returns to process 1350 for processing of the next datastream.

The foregoing description of a preferred embodiment of the invention has been presented for purposes of illustration and description. It is not intended to be exhaustive or to limit the invention to the precise forms disclosed. Obviously many modifications and variations will be apparent to practitioners skilled in this art. It is intended that the scope of the invention be defined by the following claims and their equivalents.

It should also be apparent that the described subscriber units may be used in a wide variety of other applications without departing from the scope of the present



invention. One such application contemplates the use of the described subscriber units in network access units that are used provision extend or otherwise supplement the range of existing high speed telephone or cable networks. By way of example, a hybrid DSL/wireless link is diagrammatically illustrated in Fig. 14. As is well known in the telecommunications art, in conventional high speed xDSL networks, high speed communications are made between a head end DSL modem (typically located at a central office (CO) or optical network unit (ONU)) and a remote DSL modem located on a customer's premises. The link between the central and remote modems is made on ordinary twisted pair wires. Thus xDSL system have the strong advantage of allowing high speed communications using existing wiring infrastructure. However, twisted pair wiring has significant signal attenuation and therefore, it is typically difficult or impossible to provide DSL service to customers who are located too far (e.g. more than 2 or 3 miles) from the central office/ONU. Further, even among customers within the coverage area, the loading coils and the bridge taps which are used around the binders of twisted pair wires that connect the modems, as well as other potential obstacles may make DSL technology difficult to implement in many circumstances.

In the embodiment illustrated in Figure 14, the range and/or accessibility of the DSL network is extended by placing a head end DSL modem 1430 in proximity to the remote DSL modem 1425. A suitable xDSL protocol (such as ADSL, VDSL, etc.) and modulation technique (such as DMT, DWMT, CAPs, etc.) is used to communicate between the remote DSL modem 1425 located at the customer premises and the head end DSL modem 1430 located at an appropriate location that is within range of the customer premises. By way of example, the head end DSL modem 1430 may be located at the terminal server 1410 on a nearby telephone pole 1432 from which the twisted pair drop 1435 originates that serves the customer premises. The head end DSL modem 1430 then provides the raw input data stream to the network access unit (subscriber unit) 1440 that communicates with appropriate BTSs 1445 as described above. Of course, in embodiments where a plurality of different remote DSL modems within the same neighborhood are being serviced, the head end DSL modem may multiplex the data streams from the various xDSL connections.

It is noted that the location of the described network access units may be widely varied based on the needs of a particular system. One advantage to placing the

network access units at the terminal servers is that it provides a readily accessible location where installation is relatively easy. Also, terminal servers are often located on a telephone pole as illustrated in Figure 14. This may be advantageous in that top telephone poles are relatively higher as compared to many other potential deployment  
5 locations, which may provide a clearer path between the network access unit 1440 and the BTS transceiver. This, of course may result in increased data speeds. It should be appreciated that the described arrangements can bring DSL service to a wide variety of locations using the POTS (plain old telephone service) infrastructure.

Referring next to Fig. 15 another embodiment of the present invention is  
10 illustrated. In this embodiment, the network access unit 1440 is connected to a plurality of cable modems 1460 via an appropriate cable 1470. Any suitable cable including hybrid fiber co-axial (HFC) cables, co-axial cables or fiber cables may be used as cable 1470. Like the previously described hybrid DSL link, the illustrated hybrid cable link provides the possibility of expanding the range of high speed data  
15 communications using existing infrastructure.

As suggested above, the described subscriber unit can be used as a node in virtually any network to facilitate communications between that network and other devices and/or networks. For example, with the growing popularity of home networks, a subscriber unit can be used as a node in a home network. Alternatively, a  
20 subscriber can be used in office networks and/or any other type of local area, wide area, or other networks.

Another networking concept that has attracted some attention lately is vehicle based networking. For example, people have contemplated wiring carriers such as buses, airplanes, ships and other vehicles with networks that provide multiple nodes  
25 within the vehicle for use by passengers. The described spatial multiplexing based subscriber units which take advantage of a wireless link are particularly well adapted to providing high speed access for any vehicle based network.

Referring next to Fig. 16, yet another deployment possibility for the subscriber units will be described. In the embodiment illustrated in Fig. 16, the subscriber unit  
30 1601 is utilized as a wireless interface for a repeater BTS 1610 in a cellular network. Various parties have proposed and implemented the concept of using repeater BTSs in cellular networks. Generally, a repeater BTS 1610 is designed to extend the coverage

area of a master BTS 1620 and/or cover dead spots in the master BTS's coverage area. The repeater BTS simply repeats the signals being transmitted by the master BTS. The link between the master BTS and the repeater link can be either a wireless link or a wired link. Given the high data rates that are possible using the spatial  
5 multiplexing based subscriber units, it should be apparent that the described subscriber units are particularly well suited for use in repeater BTSs.

Although a few specific deployments have been described, it should be appreciated that the described spatial multiplexing based subscriber units may be deployed in a wide variety of other situations as well.

10

## CLAIMS

1. A wireless cellular network for transmitting subscriber datastreams to corresponding ones among a plurality of subscriber units located within the cellular network, and said wireless cellular network comprising:
  - 5 base stations each including spatially separate transmitters for transmitting in response to control signals, selected substreams of each subscriber datastream on an assigned channel of a multiple access protocol; and  
logic communicating with each of the base stations and the logic for assigning an available channel on which to transmit each subscriber datastream, for routing at  
10 least a substream of each datastream to at least a selected one of the base stations and for generating control signals to configure the at least a selected one of the base stations to transmit the selected substreams to a corresponding one among the plurality of subscriber units on the assigned channel.
- 15 2. The wireless cellular network of Claim 1 wherein the logic is arranged for changing a spatial transmission configuration from a first transmitting base station to at least the first base station together with a second transmitting base station responsive to a determination that a change of a spatial reception configuration is required in order to resolve the selected substreams at the corresponding one among  
20 the plurality of subscriber units.
3. The wireless cellular network of either of claims 1 and 2 wherein the logic is arranged for changing the spatial reception configuration from a first receiving base station to at least a second base station together with a third base station responsive to  
25 a determination that a change of a spatial reception configuration is required in order to resolve the selected substreams at the corresponding one among the plurality of subscriber units.
4. The wireless cellular network of any of the preceding claims wherein the logic  
30 further comprises a parser for parsing each datastream into substreams.

5. The wireless cellular network of Claim 4, wherein:  
the parser includes responsiveness to a mode signal to parse each datastream into a variable number of substreams and to avoid parsing of each datastream; and  
5 the parser is responsive to a modulation rate of each substream.
6. The wireless cellular network of Claim 4, wherein the logic further comprises a router for routing the substreams to at least a selected one of the base stations and each of the base stations further comprises a selector responsive to the control signals  
10 generated by the logic to inject a routed one of the substreams onto the channel assigned by the logic.
7. The wireless cellular network of Claim 6, wherein each of the base stations further comprises a selector responsive to the control signals generated by the logic to  
15 inject routed ones of the substreams onto both the channel assigned by the logic as well as onto selected ones of the spatially separate transmitters.
8. The wireless cellular network of any of the preceding claims wherein the logic further comprises:  
20 a detector to detect modes of the subscriber datastreams from the first network and to generate a mode signal corresponding to the mode of each of the subscriber datastreams;  
a parser responsive to the mode signal to parse the datastream into a variable number of substreams and to avoid parsing of the datastream; and  
25 a router for routing both an unparsed datastream as well as a variable number of substreams to at least a selected one of the base stations.
9. The wireless cellular network of Claim 8, wherein the modes of the datastreams include voice mode and data mode and wherein further the parser is

responsive to a voice mode signal avoids parsing of the datastream, and responsive to a data mode signal parses the datastream into a variable number of substreams.

10. The wireless cellular network of Claim 8, wherein the modes of the  
5 datastreams include high bit rate and low bit rate and wherein further the parser avoids parsing of a low bit rate datastream, and parses a high bit rate datastream into a variable number of substreams.

11. The wireless cellular network of Claim 8, wherein the modes of the  
10 datastreams include low QoS requirement and high QoS requirement and wherein further the parser avoids parsing a datastream with a low QoS requirement, and parses a datastream with a high QoS requirement into a variable number of substreams.

15 12. The wireless cellular network of any of Claims 8-11, wherein each of the base stations further comprises:

a selector responsive to the control signals generated by the logic to inject  
routed ones of the substreams as well as the unparsed datastream onto both the  
channel assigned by the logic as well as a selected one of the spatially separate  
20 transmitters.

13. The wireless cellular network of any of the preceding claims wherein each of  
the base stations further comprises a training module for injecting a training sequence  
into the transmissions of the spatially separable transmitters.

25

14. The wireless cellular network of any of the preceding claims, wherein each of  
the base stations further comprises:

spatially separate receivers for receiving composite signals resulting from the  
spatially separate transmission of spatially separate source signals corresponding to

selected substreams of an uplink subscriber datastream from selected ones of the subscriber units, on an assigned channel of the multiple access protocol;

5 a spatial processor configurable in response to the control signal to separate the composite signals into estimated source signals based on information obtained during the transmission of known data patterns from the selected ones of the subscriber units; and

a combiner for combining the estimated source signals into a corresponding uplink subscriber datastream.

10 15. The wireless cellular network of Claim 14, wherein the spatial processor further comprises:

a configurable logic responsive to the control signal to vary both a number of the composite signals separated as well as the number of the estimated source signals.

15 16. The wireless cellular network of any of the preceding claims, wherein each of the base stations further comprise:

mobility detectors for determining a mobility of each of the subscriber units and generating a mobility signal; and

20 a training module responsive to the mobility signal for varying at least one of: an injection interval and duration of a training sequence into the transmissions of the spatially separable transmitters.

17. The wireless cellular network of any of the preceding claims, wherein each of the base stations further comprises transmit processes selected from at least one of a  
25 group of transmit processes consisting of: diversity, space coding, space time coding and beam forming.

18. A subscriber unit for use in a cellular system with base stations each including spatially separate transmitters for transmitting selected substreams of at least one of a

plurality of subscriber downlink datastreams on an assigned channel of a multiple access protocol, and the subscriber unit comprising:

5           spatially separate receivers for receiving on the assigned channel of the multiple access protocol composite signals resulting from the spatially separate transmission the selected substreams;

          a spatial processor to separate the composite signals into estimated subscriber substreams, and to signal the base stations when a change of a spatial transmission configuration is required in order to resolve the composite signals into estimated substreams; and

10           a combiner for combining the estimated substreams into a corresponding subscriber datastream.

19.       The arrangement of Claim 18, wherein the spatial processor further comprises responsiveness to a control signal from the base station to vary a number of estimated  
15       subscriber substreams.

20.       The arrangement of Claim 18 or 19, wherein the spatially separate receivers further comprise:

20           a first selector responsive to the control signal to assign a channel on which to operate said spatially separate receivers; and

          a second selector responsive to the control signal to enable selected ones of the spatially separate receivers on the assigned channel to receive the composite signals.

21.       The arrangement of any of Claims 18-20, wherein the spatial processor further  
25       comprises a configurable logic responsive to the control signal to vary both a number of the composite signals separated as well as the number of the estimated source signals and to evaluate the composite signals over time.



22. The arrangement of any of Claims 18-21, wherein the spatial processor further comprises an evaluator to evaluate the estimated source signals during a transmission interval in which at least one of the base stations transmits the known data patterns and to initiate the signal to the at least one of the base stations when a change of the spatial transmission configuration is required.

5

23. The arrangement of any of Claims 18-22, wherein the combiner includes responsiveness to the control signal to vary a number of estimated source signals combined into a corresponding subscriber datastream.

10

24. The arrangement of any of Claims 18-23, further comprising:  
a parser for parsing an uplink subscriber datastream into substreams; and  
spatially separate transmitters for transmitting the substreams of the uplink subscriber datastream on an assigned channel of a multiple access protocol.

15

25. The arrangement of any of Claims 18-24, wherein the subscriber unit further comprises receive processors from at least one of a group of receive processes consisting of diversity, space decoding, space-time decoding, beam forming and interference canceling.

20

26. A wireless cellular network for transmitting subscriber downlink datastreams from a first network to subscribers located within the wireless cellular network, and said wireless cellular network comprising:

base stations each configured for spatially separate transmission of selected substreams of each subscriber downlink datastream on an assigned channel of a multiple access protocol;

25

subscriber units each configured for spatially separate reception on the assigned channel of the selected substreams and for combining the substreams into the corresponding subscriber datastream; and

a logic communicating with each of the base stations and to the first network and the logic configured to route at least a substream of each subscriber downlink datastream to at least a selected one of the base stations and further configured to vary the routing between a single base station and multiple base stations to vary a spatial  
5 transmission configuration of the selected substreams.

27. A wireless cellular network for receiving subscriber datastreams at corresponding ones among a plurality of base stations located within the cellular network, and said wireless cellular network comprising:  
10 a plurality of subscriber units each including spatially separate transmitters for transmitting, in response to control signals, selected substreams of each subscriber datastream on an assigned channel of a multiple access protocol; and

logic communicating with each of the base stations and the logic for generating control signals to configure selected ones of the base stations to receive  
15 composite signals resulting from the spatially separate transmission of the selected substreams from a corresponding one among the plurality of subscriber units on the assigned channel, for converting the composite signals into estimate substreams and for combining the estimated substreams of each subscriber datastream into each subscriber datastream.

20

28. The logic of Claim 27, further for changing the spatial reception configuration from a first receiving base station to at least the first base station together with a second base station responsive to a determination that a change of a spatial reception configuration is required in order to resolve the composite signals into estimated  
25 substreams.

30

29. A wireless cellular network for transmitting subscriber datastreams to corresponding ones among a plurality of subscriber units located within the cellular network, and said wireless cellular network comprising:

- 5 base stations each including at least one transmitter for transmitting, in response to control signals, selected substreams of each subscriber datastream on an assigned channel of a multiple access protocol; and
- logic communicating with each of the base stations and the logic for assigning an available channel on which to transmit each subscriber datastream, for routing at  
10 least a substream of each datastream to at least a selected one of the base stations and for generating control signals to configure the at least a selected one of the base stations to transmit the selected substreams to a corresponding one among the plurality of subscriber units on the assigned channel.

- 15 30. The arrangement of Claim 29, wherein the logic is further arranged for changing a spatial transmission configuration from a first transmitting base station to at least the first base station together with a second transmitting base station responsive to a determination that a change of a spatial reception configuration is required in order to resolve the selected substreams at the corresponding one among  
20 the plurality of subscriber units.

31. The arrangement of Claim 29 or 30, wherein the logic is further arranged for changing the spatial reception configuration from a first receiving base station to at least a second base station together with a third base station responsive to a  
25 determination that a change of a spatial reception configuration is required in order to resolve the selected substreams at the corresponding one among the plurality of subscriber units.

32. The arrangement of any one of Claims 29-31 wherein the logic is further  
30 arranged for changing a spatial transmission configuration from a first transmitting base station together with a second transmitting base station to at least the first

transmitting base station together with a third transmitting base station responsive to a determination that a change of a spatial reception configuration is required in order to resolve the selected substreams at the corresponding one among the plurality of subscriber units.

5

33. The arrangement of any one of Claims 29-32, wherein the logic is further arranged for changing a spatial transmission configuration from a first transmitting base station together with a second transmitting base station to at least the third transmitting base station together with a fourth transmitting base station responsive to a determination that a change of a spatial reception configuration is required in order to resolve the selected substreams at the corresponding one among the plurality of subscriber units.

34. A method for transmitting subscriber downlink datastreams from base stations to corresponding ones among a plurality of subscriber units, and said method for transmitting comprising the acts of:

routing at least a substream of each subscriber downlink datastream to selected ones of the base stations;

transmitting the at least a substream of each subscriber downlink datastream from the selected ones of the base stations on an assigned channel of a multiple access protocol; and

re-routing at least a substream of each subscriber downlink datastream between a single base station and multiple base stations responsive to a determination that a change of a spatial transmission configuration of the at least a substream of each subscriber downlink datastream signal is required.

35. The method of Claim 34, wherein the at least a substream comprises at least one of: a whole subscriber downlink datastream and substreams of the subscriber downlink datastream.

30

36. The method of Claim 34 or 35, wherein the routing act and re-routing acts further comprise the acts of:

parsing each of the subscriber downlink datastreams into a configurable number of substreams; and

5 configuring the at least a selected one of the base stations to transmit selected substreams of each subscriber downlink datastream to a corresponding one among the plurality of subscriber units on the assigned channel.

37. The method of Claim 36, wherein the parsing act further comprises the acts of:

10 determining a mode for each of the subscriber downlink datastreams;

parsing the subscriber downlink datastream into a plurality of substreams responsive to a first mode determination in said act of determining; and

avoiding the parsing of the subscriber downlink datastream responsive to a second mode determination in said act of determining.

15

38. The method of Claim 37, wherein the first mode and the second mode correspond to at least one of: a transmission rate of each of the subscriber downlink datastreams, and a data type of each of the subscriber downlink datastreams.

20 39. The method as recited in any of Claims 34-38, wherein the determination that a change of a spatial transmission configuration is required corresponds to a signal generated by a corresponding one of the subscriber units.

40. The method as recited in any of Claims 34-39, further comprising the acts of:

25 receiving at a corresponding one among the plurality of subscriber units signals generated in said transmitting act;

determining a number of substreams to be derived from the signals;

separating the signals into the number of substreams determined in said act of determining; and

combining the substreams into a corresponding subscriber downlink datastream.

41. A method of receiving subscriber downlink datastreams transmitted from a plurality of spatially separate transmitters, comprising the acts of:

receiving signals generated from at least one of the plurality of spatially separate transmitters;

determining a number of substreams to be derived from the signals;

separating the signals into the number of substreams determined in said act of determining; and

combining the substreams into a corresponding subscriber downlink datastream.

42. The method Claim 41, wherein said separating act further comprises the acts of:

determining that a change of a spatial transmission configuration is required in order to separate the number of substreams; and

changing the spatial transmission configuration responsive to said act of determining.

20

43. A wireless cellular network for transmitting subscriber datastreams to corresponding ones among a plurality of subscriber units located within the cellular network, and said wireless cellular network comprising:

means for routing at least a substream of each subscriber downlink datastream to selected ones of the base stations;

means for transmitting the at least a substream of each subscriber downlink datastream from the selected ones of the base stations on an assigned channel of a multiple access protocol; and

means for re-routing the at least a substream of each subscriber downlink datastream between a single base station and multiple base stations responsive to a signal from a corresponding one of the subscriber units requesting a change of spatial transmission configuration.

5

44. A subscriber unit for use in a cellular system with base stations each including spatially separate transmitters for transmitting selected substreams of at least one of a plurality of subscriber downlink datastreams on an assigned channel of a multiple access protocol, and the subscriber unit comprising:

10 means for receiving signals generated from at least one of the plurality of spatially separate transmitters;

means for determining a number of substreams to be derived from the signals; means for separating the signals into the number of substreams determined in said act of determining;

15 means for combining the substreams into a corresponding subscriber downlink datastream; and

means for signaling the base when a change of a spatial transmission configuration is required in order to resolve the composite signals into estimated substreams.

20

45. A wireless cellular remote unit for transmitting a datastream to at least one base station that is part of a cellular network, the wireless cellular remote unit comprising:

a plurality of spatially separate antennas;

25 a transmitter for transmitting a plurality of substreams of the datastream on an assigned channel or slot of a multiple access protocol, the transmitter being arranged to apply each substream to an associated one of the spatially separate antennas, the transmitter further being responsive to a control signal from the base station to vary the number of applied substreams.

30

46. The unit of Claim 45, wherein the remote unit communicates with a first network to provide the first network with access to the cellular network.
47. The unit of Claim 46 wherein the first network is one selected from the group consisting of a home network, a vehicle based network and a local area network.
48. A unit as recited in any one of claims 45-47 wherein the subscriber unit is incorporated into a bridge or router to provide a wireless bridge or router.
49. The unit of any one of claims 45-48, wherein the remote unit is one of a fixed unit and a mobile unit.
50. The unit of any one of claims 45-49, wherein the remote unit further comprises transmit processes from at least one of a group of transmit processes consisting of diversity, space coding, space-time coding, space frequency coding, beam forming and interference canceling.
51. The unit of any one of claims 45-50, wherein the transmitter includes a parser for parsing the datastream into the substreams.
52. The wireless cellular remote unit of Claim 51, wherein the parser is responsive to at least one of:
- a mode signal to parse the datastream into a variable number of substreams and to avoid parsing of each datastream; and
  - a modulation rate of each substream.
53. The unit of any one of claims 45-52 further comprising a selector arranged to inject a routed one of the substreams onto the assigned channel.



54. A wireless cellular remote unit for transmitting a datastream to at least one base station that is part of a cellular network, the wireless cellular remote unit comprising:

5 a plurality of spatially separate antennas;

a transmitter for transmitting a plurality of substreams of the datastream on an assigned channel or slot of a multiple access protocol, the transmitter being arranged to apply each substream to an associated one of the spatially separate antennas;

10 a detector to detect a mode of the datastream and to generate a corresponding mode signal; and

a parser responsive to the mode signal to parse the datastream into a variable number of substreams and to avoid parsing of the datastream.

55. The wireless cellular remote unit of Claim 54, wherein the modes of the datastream includes at least one of:

voice mode and data mode and wherein further the parser responsive to a voice mode signal avoids parsing of the datastream, and responsive to a data mode signal parses the datastream into a variable number of substreams;

20 high bit rate and low bit rate and wherein further the parser avoids parsing of a low bit rate datastream, and parses a high bit rate datastream into a variable number of substreams; and

low QoS requirement and high QoS requirement and wherein further the parser avoids parsing a datastream with a low QoS requirement, and parses a datastream with a high QoS requirement into a variable number of substreams.

25

56. A wireless cellular remote unit for receiving a downlink datastream from and transmitting an uplink datastream to at least one base station that is part of a cellular network, the wireless cellular remote unit comprising:

a plurality of spatially separate antennas;

a transmitter for transmitting a plurality of uplink substreams of the uplink datastream on an assigned channel or slot of a multiple access protocol, the transmitter being arranged to apply each uplink substream to an associated one of the spatially separate antennas;

5 a receiver including a spatial processor arranged to separate a composite downlink signal received by the spatially separate antennas into estimated substreams, and a combiner for combining the estimated substreams into a corresponding subscriber datastream, the receiver being arranged to signal the base stations when a change of a spatial transmission configuration is required in order to resolve the  
10 composite signals into estimated substreams.

57. A wireless cellular remote unit as recited in claim 56 wherein the remote unit takes the form of a network access unit that is a node in a network that facilitates communication outside of the network.

15

58. A method of transmitting a datastream from a remote unit to at least one cellular base station in a cellular network, the method comprising:

forming a plurality of substreams from the datastream, wherein the number of substreams formed is determined in response to a control signal received from one of  
20 the base stations; and

transmitting the substreams in parallel from spatially separate antennas on an assigned channel or slot using a multiple access protocol.

59. A method of communicating between a remote location and one or more base  
25 stations in a cellular network, the method comprising:

transmitting a datastream from the remote location to a wireless access unit over a wired connection using a communications protocol selected from the group consisting of an xDSL protocol, a cable modem protocol and a networking protocol;

forming a plurality of substreams from the datastream; and

transmitting the substreams to the one or more base stations in parallel from spatially separate antennas on an assigned channel or slot using a multiple access protocol.

5 60. A wireless cellular remote unit for receiving a downlink datastream from and transmitting an uplink datastream to at least one base station that is part of a cellular network, the wireless cellular remote unit comprising:

a plurality of spatially separate antennas;

10 transmission means for transmitting a plurality of uplink substreams of the uplink datastream on an assigned channel or slot of a multiple access protocol, the transmitter being arranged to apply each uplink substream to an associated one of the spatially separate antennas; and

15 receiver means arranged to separate a composite downlink signal received by the spatially separate antennas into estimated substreams, and combine the estimated substreams into a corresponding subscriber datastream.

61. A wireless cellular remote unit as recited in claim 60 wherein:

20 the remote unit is arranged to signal the base stations when a change of a spatial transmission configuration is required by the receiver in order to resolve the composite signals into estimated substreams; and

the transmitter is responsive to a control signal from the base station to vary the number of applied substreams.

25 62. A repeater base station suitable for use in conjunction with a master base station that is part of a cellular network, the repeater base station including:

a slave base station; and

a wireless interface unit comprising,

a plurality of spatially separate antennas; and

a transmitter for transmitting a plurality of substreams of a datastream on an assigned channel or slot of a multiple access protocol, the transmitter being arranged to apply each substream to an associated one of the spatially separate antennas, the transmitter further being responsive to a control signal from the master base station to vary the number of applied substreams.

63. A communications network comprising:  
a master station controller;  
at least one base station controller that communicates with the master station controller;  
a plurality of base station, each base station being arranged to communicate with an associated one of the base station controllers, wherein at least one of the base stations is designated as a master base station; and  
a repeater base station as recited in claim 62.

64. A unit for use in a communications network that delivers DSL service to customers, the unit comprising:  
a head end DSL modem arranged to communicate with a remotely located DSL modem using a DSL protocol; and  
a wireless access unit comprising arranged to receive a datastream from the head end DSL modem, the wireless access unit including, a plurality of spatially separate antennas and a transmitter for transmitting a plurality of substreams of the datastream on an assigned channel or slot of a multiple access protocol, the transmitter being arranged to apply each substream to an associated one of the spatially separate antennas.

65. A unit for use in a communications network that delivers DSL service to customers, the unit comprising:

a head end DSL modem arranged to communicate with a remotely located DSL modem using a DSL protocol; and

a wireless access unit comprising,

5 spatially separate receivers for receiving on an assigned channel of a multiple access protocol composite signals resulting from spatially separate transmission selected substreams communicated from a base station in the communications network;

a spatial processor to separate the composite signals into estimated slave substreams; and

10 a combiner for combining the estimated substreams into a corresponding slave datastream, wherein the slave datastream is passed to the head end DSL modem for transmission to a remotely located DSL modem using a DSL protocol.

66. A unit for use in a communications network that delivers high speed data delivery service to customers, the unit comprising:

a head end cable modem unit arranged to communicate with a remotely located cable modem over a cable;

20 a wireless access unit comprising arranged to receive a datastream from the head end cable modem, the wireless access unit including, a plurality of spatially separate antennas and a transmitter for transmitting a plurality of substreams of the datastream on an assigned channel or slot of a multiple access protocol, the transmitter being arranged to apply each substream to an associated one of the spatially separate antennas.

25 67. A unit for use in a communications network that delivers high speed data delivery service to customers, the unit comprising:

a head end cable modem unit arranged to communicate with a remotely located cable modem over a cable;

a wireless access unit comprising,

spatially separate receivers for receiving on an assigned channel of a multiple access protocol composite signals resulting from spatially separate transmission selected substreams communicated from a base station in the communications network;

5 a spatial processor to separate the composite signals into estimated slave substreams; and

a combiner for combining the estimated substreams into a corresponding slave datastream, wherein the slave datastream is passed to the head end cable modem for transmission to a remotely located cable modem.

10

68. A unit as recited in claim 66 or 67 wherein the cable is one selected from the group consisting of a hybrid fiber co-axial cable, a co-axial cable and a fiber cable.

69. A repeater base station suitable for use in conjunction with a master base station  
15 that is part of a cellular network, the repeater base station including:

a slave base station; and

a wireless interface unit comprising,

20 spatially separate receivers for receiving on an assigned channel of a multiple access protocol composite signals resulting from spatially separate transmission selected substreams communicated from a master base station;

a spatial processor to separate the composite signals into estimated slave substreams; and

25 a combiner for combining the estimated substreams into a corresponding slave datastream, wherein the slave datastream is passed to the slave base station for transmission by the slave base station.

70. A communications network comprising:

a master station controller;

at least one base station controller that communicates with the master station controller;

a plurality of base station, each base station being arranged to communicate with an associated one of the base station controllers, wherein at least one of the base stations is designated as a master base station; and

a repeater base station as recited in claim 69.

71. A unit as recited in claim 64 or 65 wherein the unit is coupled to a terminal server in a POTS communications network such that a first link between the remotely located DSL modem and the head end DSL modem takes the form of twisted pair wiring and a second link between the wireless access unit and a base station takes the form of a wireless link.

72. An arrangement as recited in any of the preceding claims, wherein the multiple access protocol is selected from at least one of a group of multiple access protocols consisting of: code-division multiple access, frequency-division multiple access, time-division multiple access, space-division multiple access, orthogonal frequency division multiple access (OFDMA), wavelength division multiple access (WDMA), wavelet division multiple access, orthogonal division multiple access (ODMA) and quasi-orthogonal division multiple access (ODMA) techniques.

73. An arrangement as recited in any of the preceding claims, wherein the assigned channel comprises, within a transmission bandwidth, at least one of: a frequency-division, a time-division, a spatial-division, a code-division, orthogonal frequency division multiple access (OFDMA), wavelength division multiple access (WDMA), wavelet division multiple access or any other orthogonal division multiple access (ODMA)/quasi-orthogonal division multiple access techniques.

74. The arrangement of any of the preceding claims wherein the base stations receive the plurality of subscriber downlink datastreams from at least one of a group of networks consisting of: a public switched telephone network, a local area network, a wide area network, a satellite network, an adhoc network, a virtual private network,  
5 an intranet and an internet.

75. The arrangement of any of the preceding claims, wherein the base stations include satellites.

10 76. An arrangement as recited in any of the preceding claims wherein the subscriber unit is incorporated into a bridge or router to provide a wireless bridge or router.

15 77. The logic of Claim 27 or 28 , further for changing the spatial reception configuration from a first receiving base station to at least a second base station together with a third base station responsive to a determination that a change of a spatial reception configuration is required in order to resolve the composite signals into estimated substreams.

20



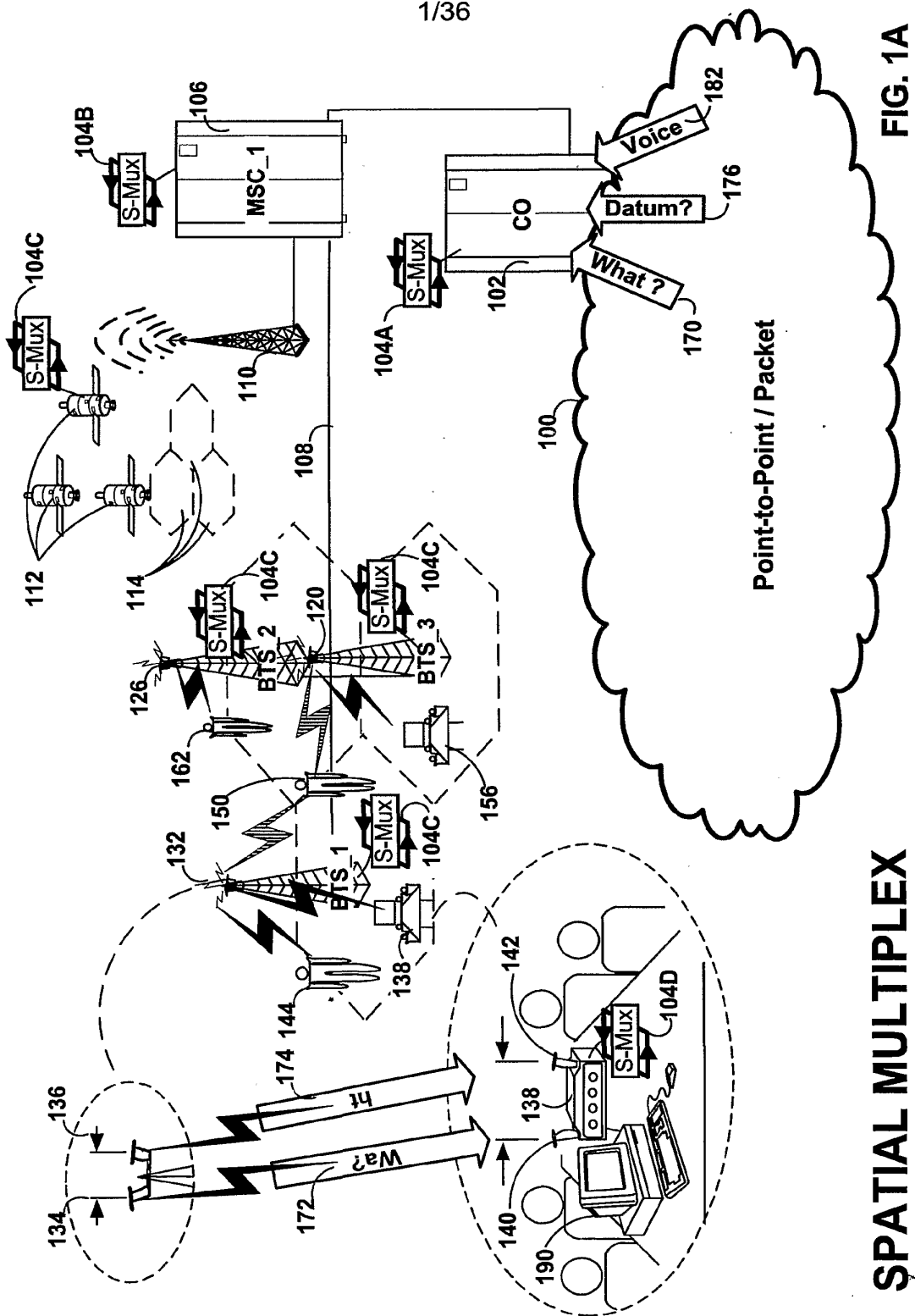


FIG. 1A

**SPATIAL MULTIPLEX**

2/36

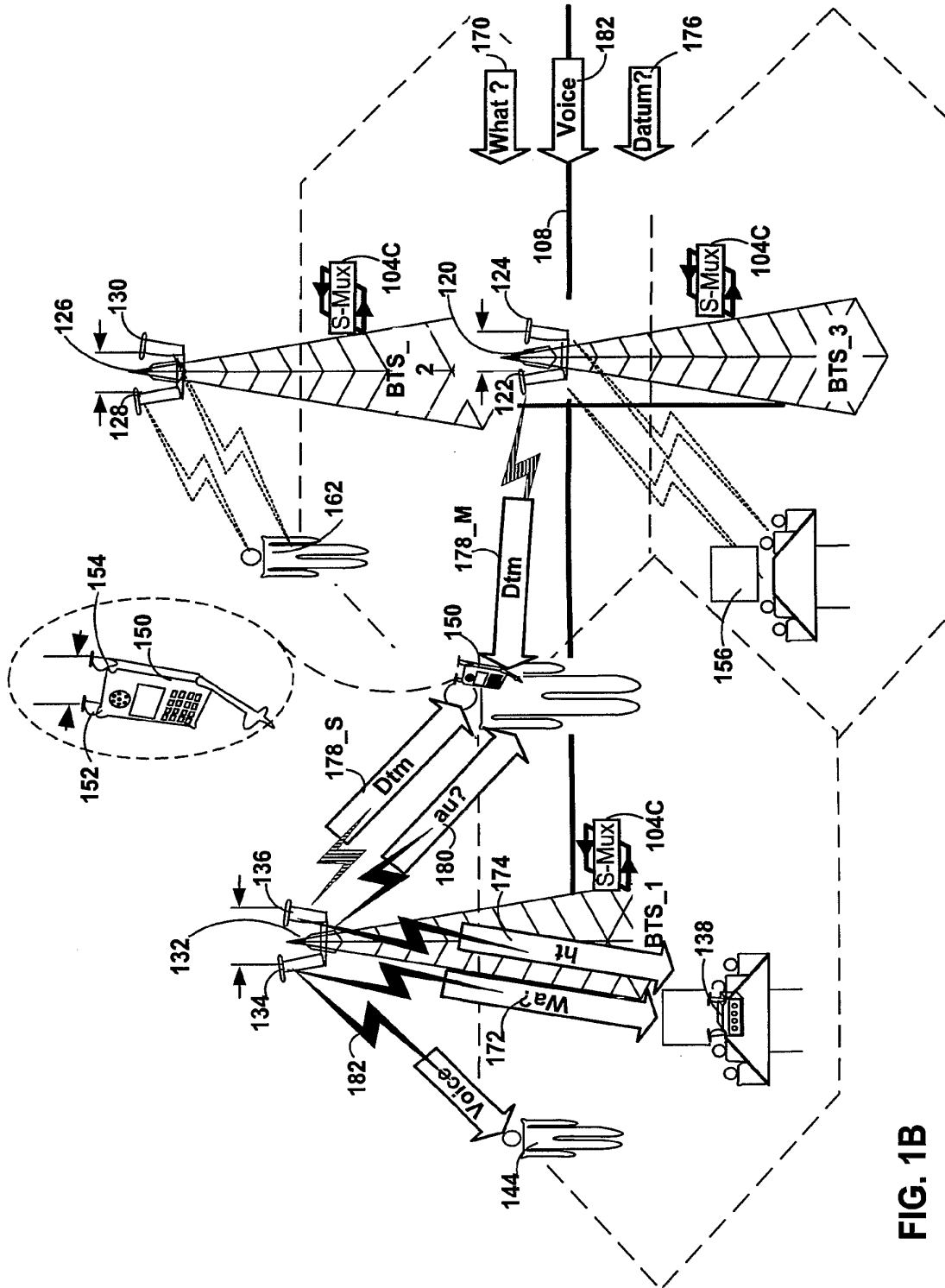


FIG. 1B

SUBSTITUTE SHEET (RULE 26)

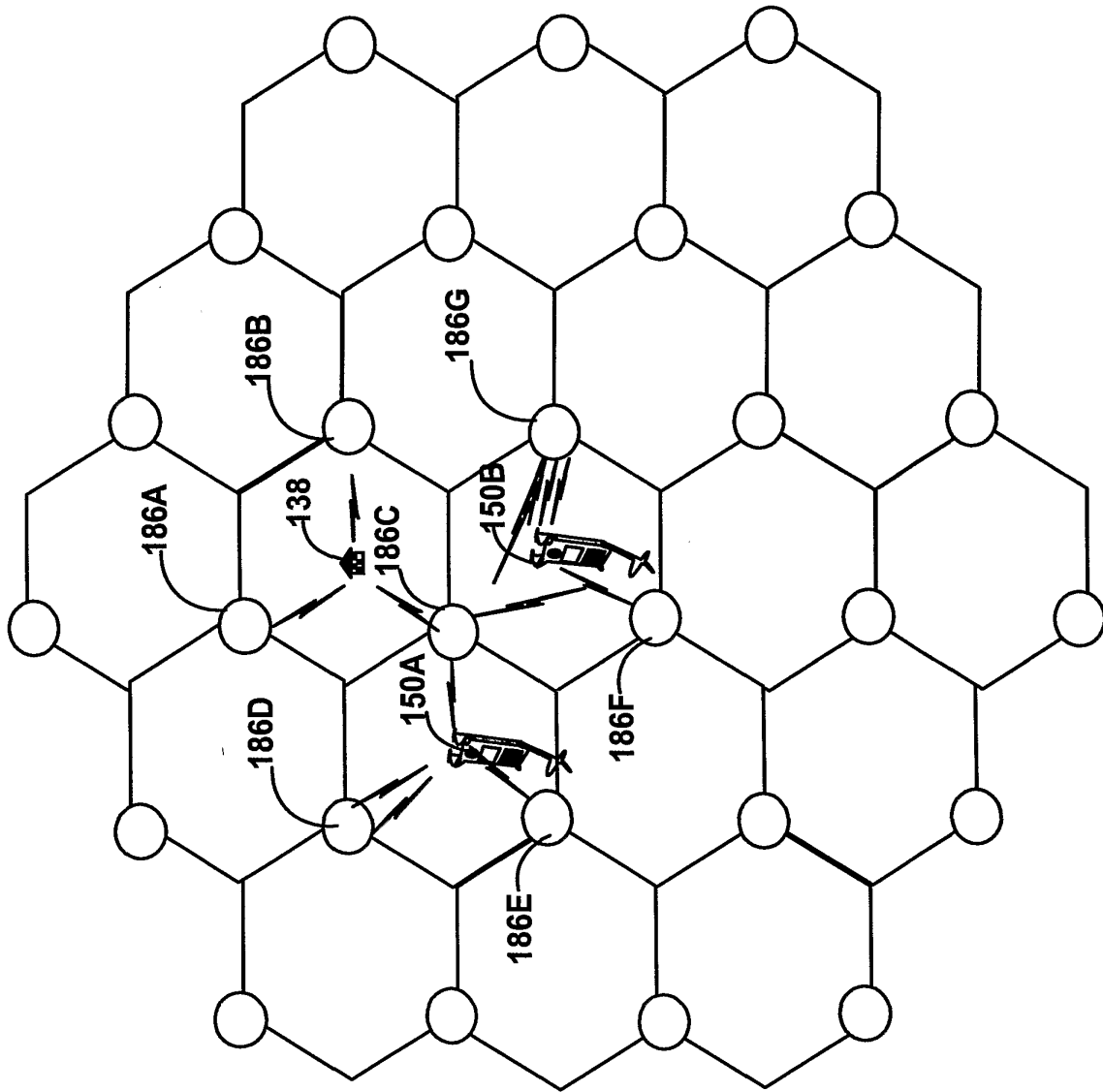


FIG.1C

SUBSTITUTE SHEET (RULE 26)

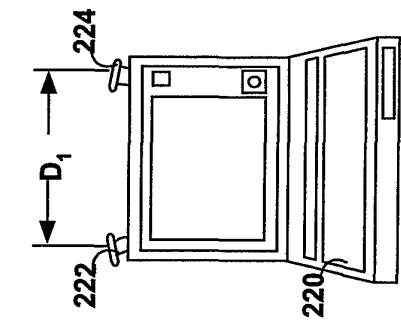


FIG. 2F

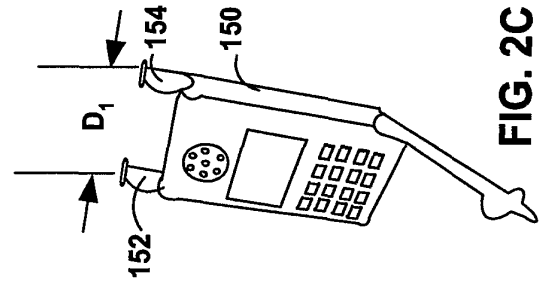


FIG. 2C

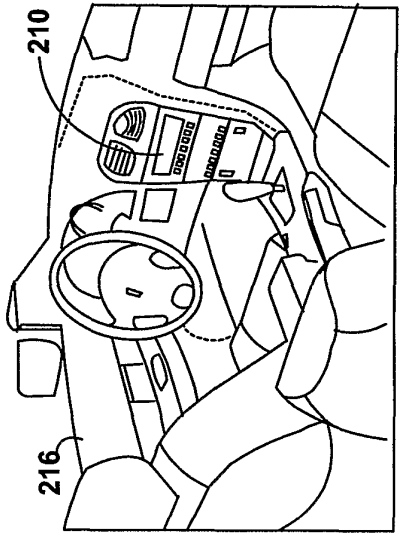


FIG. 2E

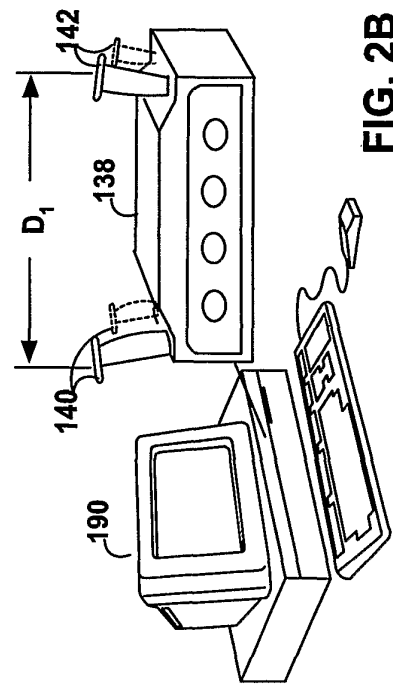


FIG. 2B

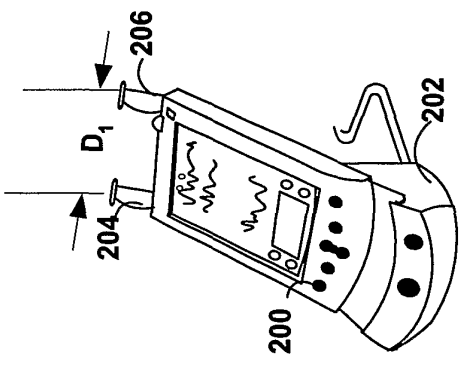


FIG. 2D

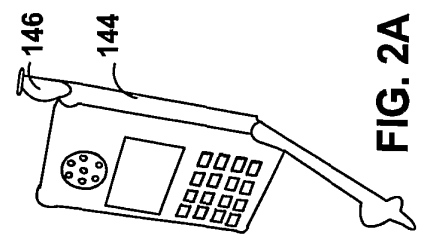


FIG. 2A

SUBSTITUTE SHEET (RULE 26)

5/36

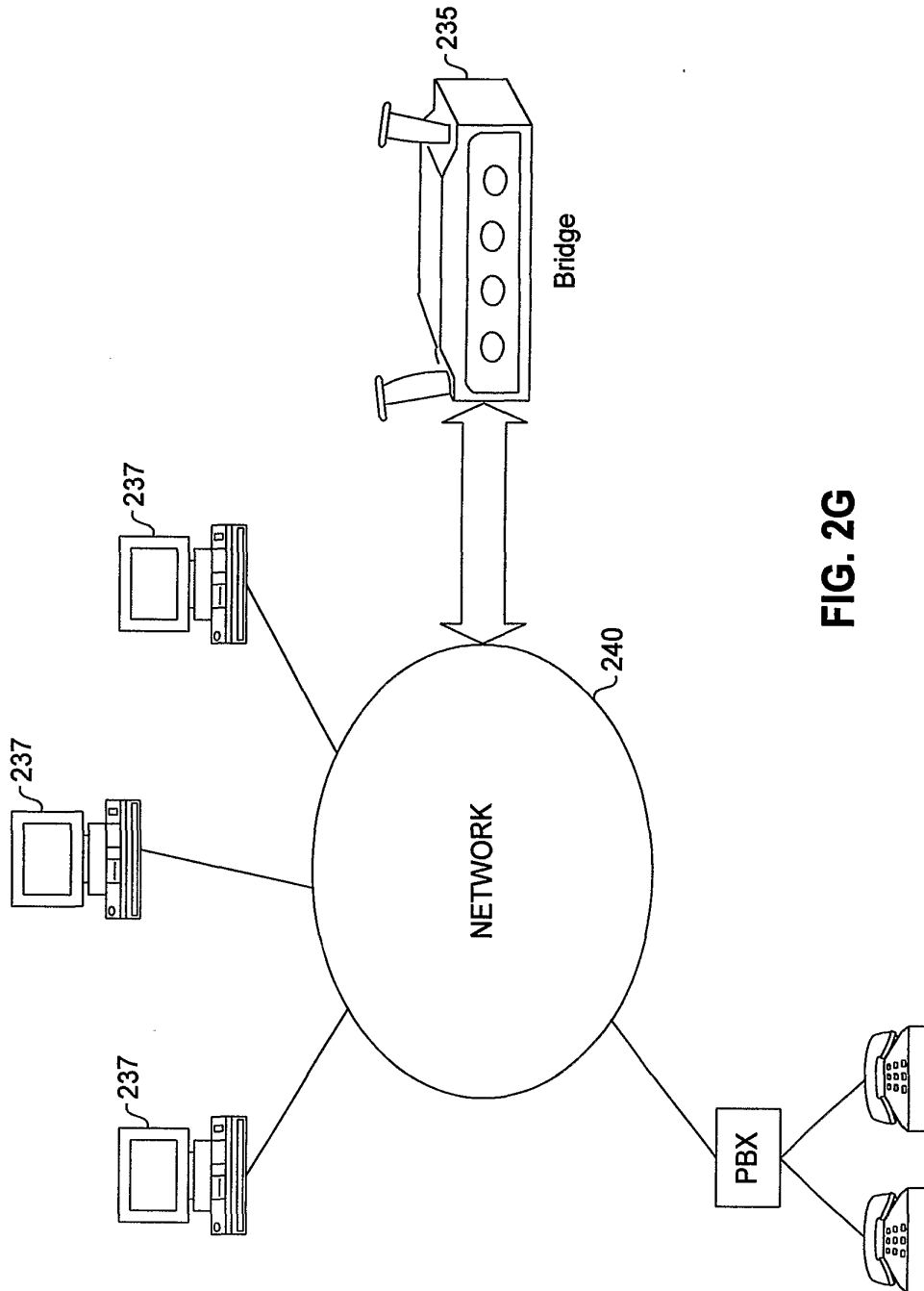


FIG. 2G

SUBSTITUTE SHEET (RULE 26)

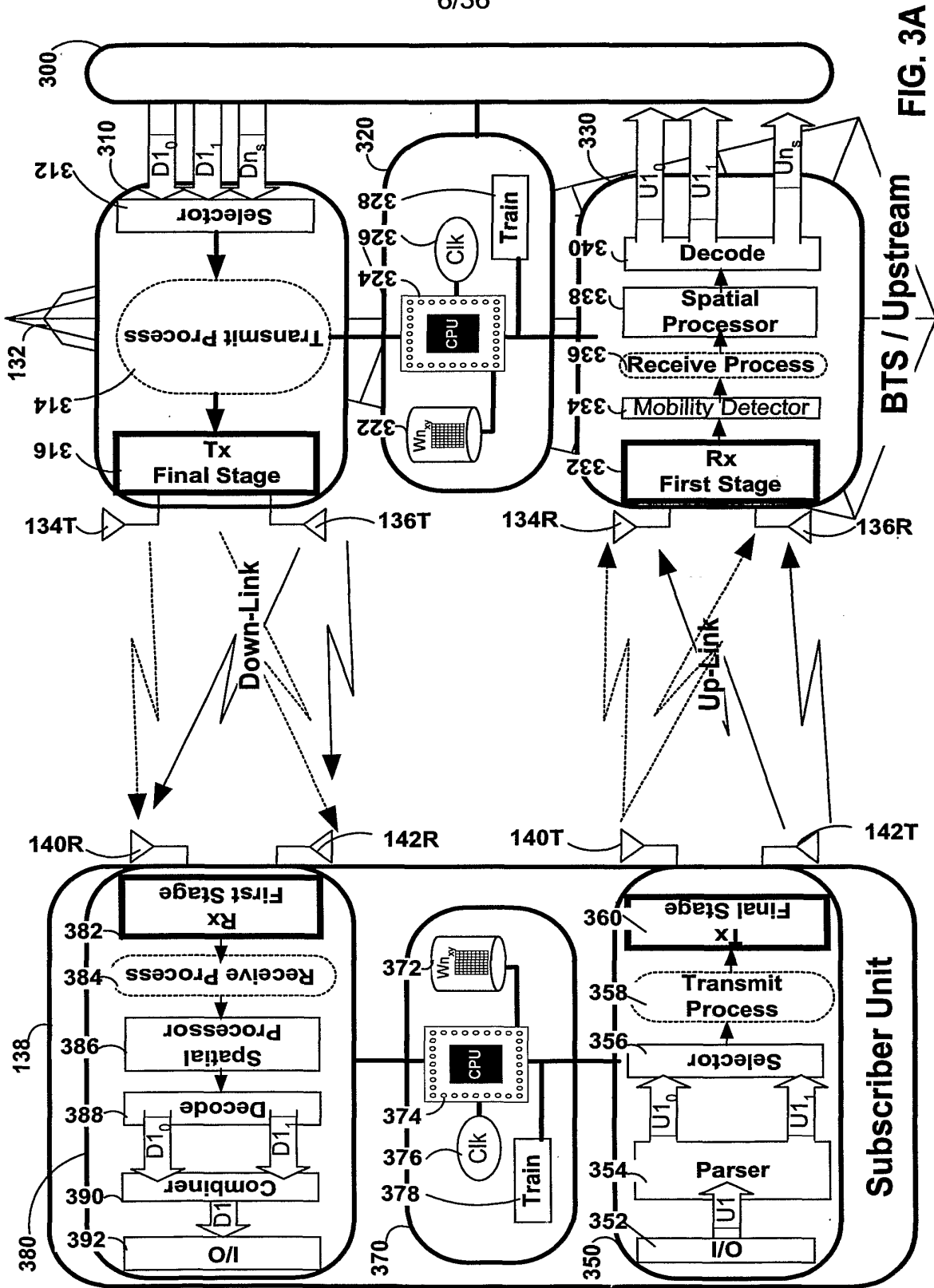


FIG. 3A

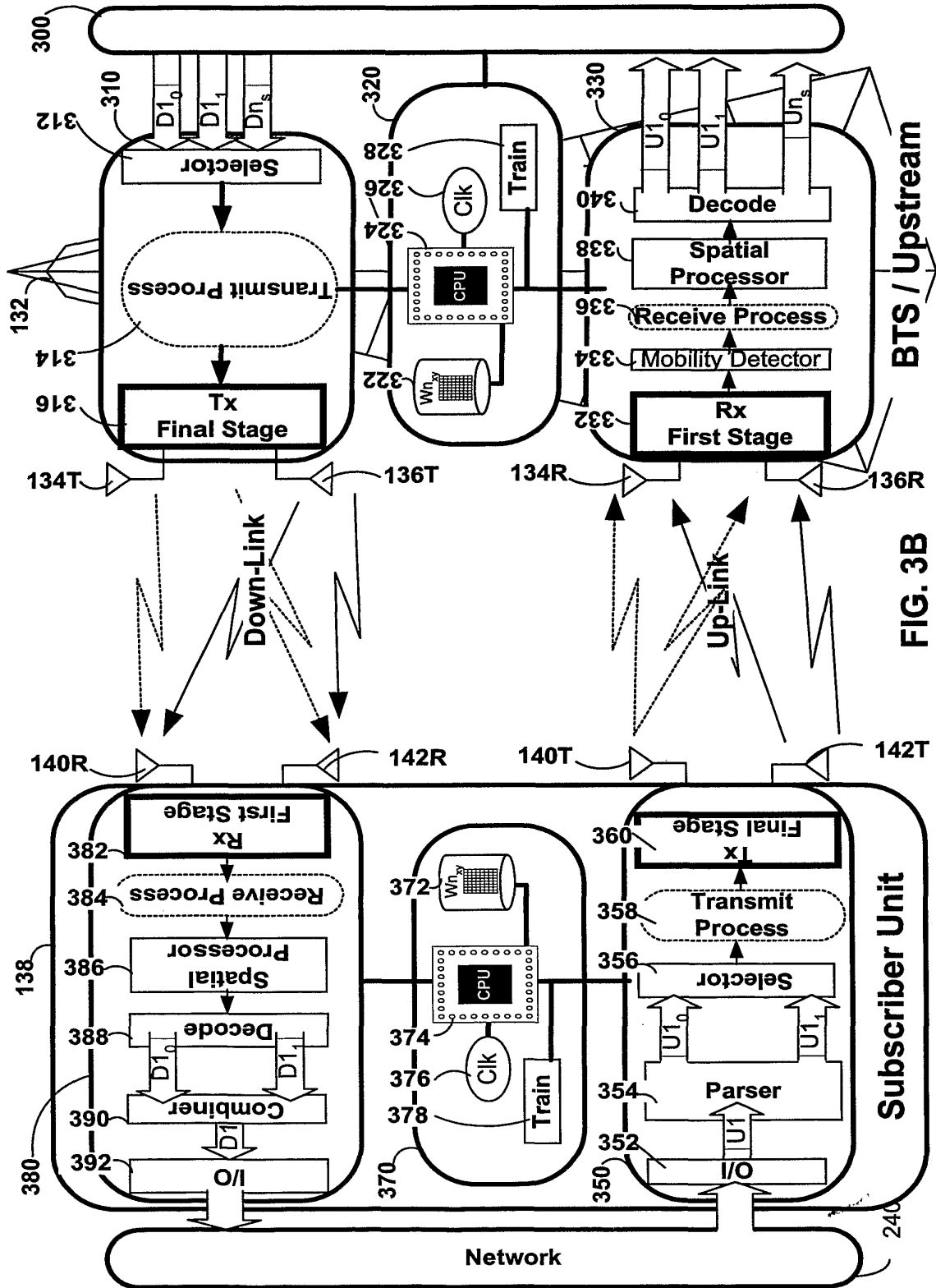


FIG. 3B







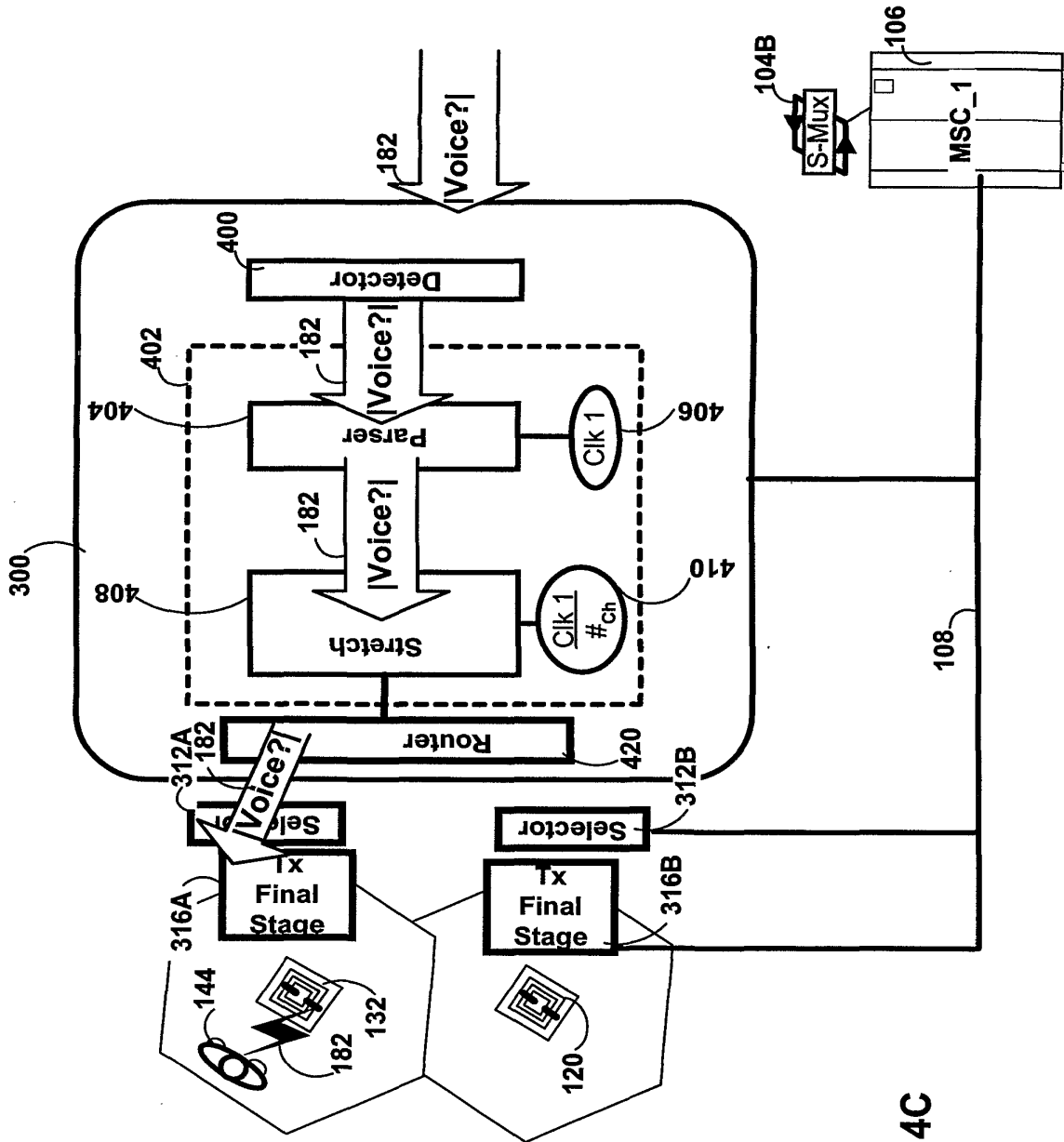


FIG. 4C

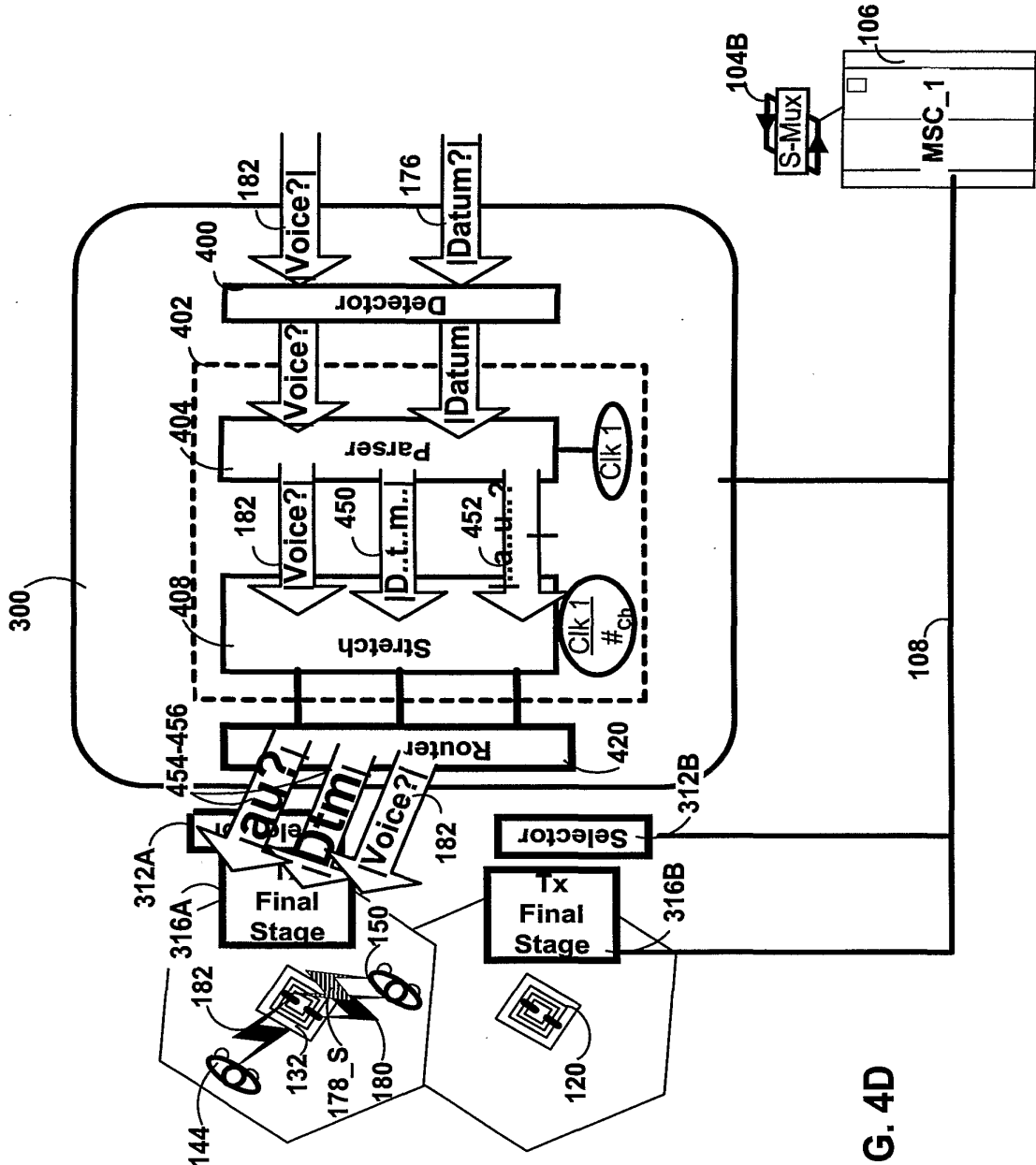


FIG. 4D

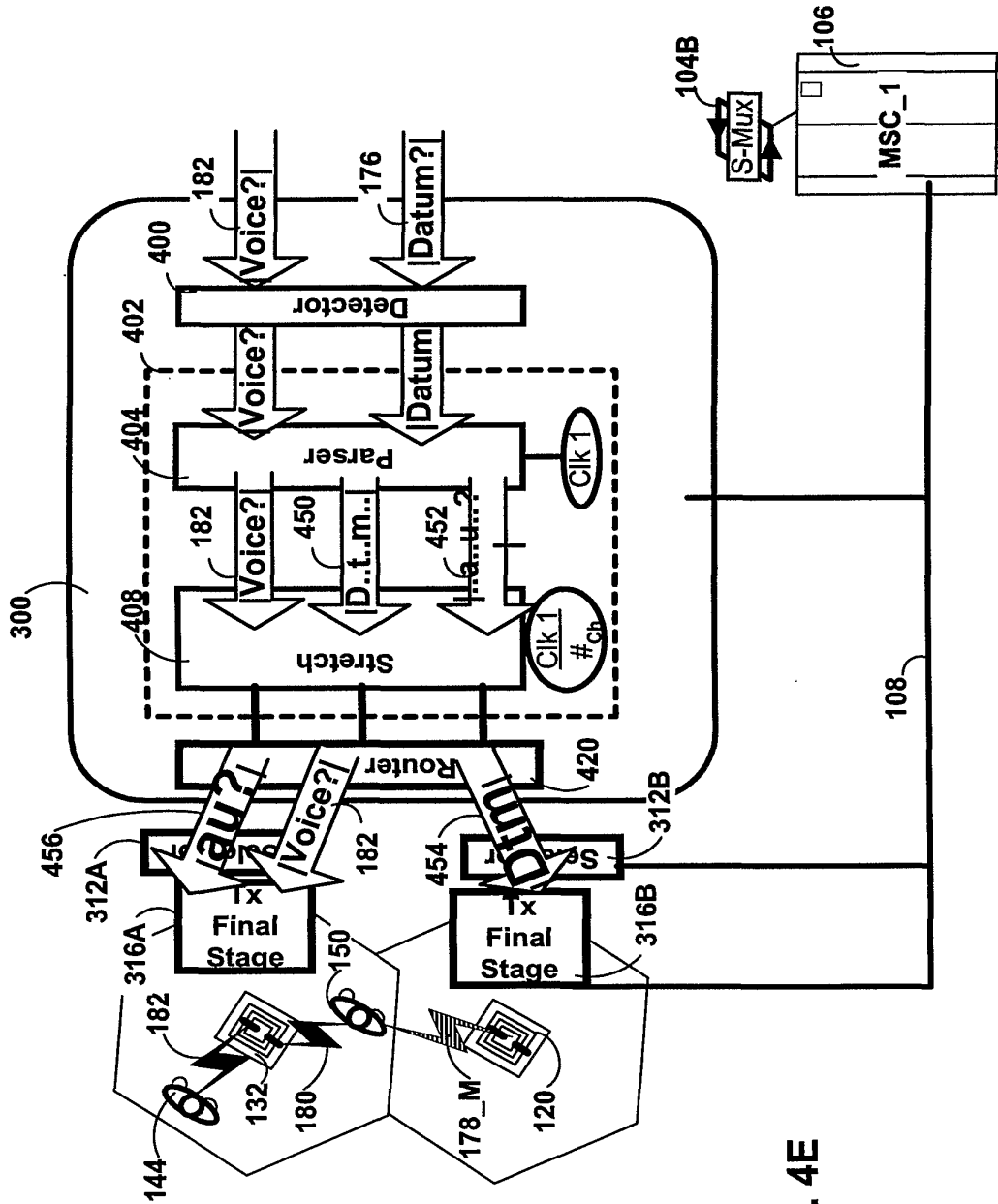


FIG. 4E

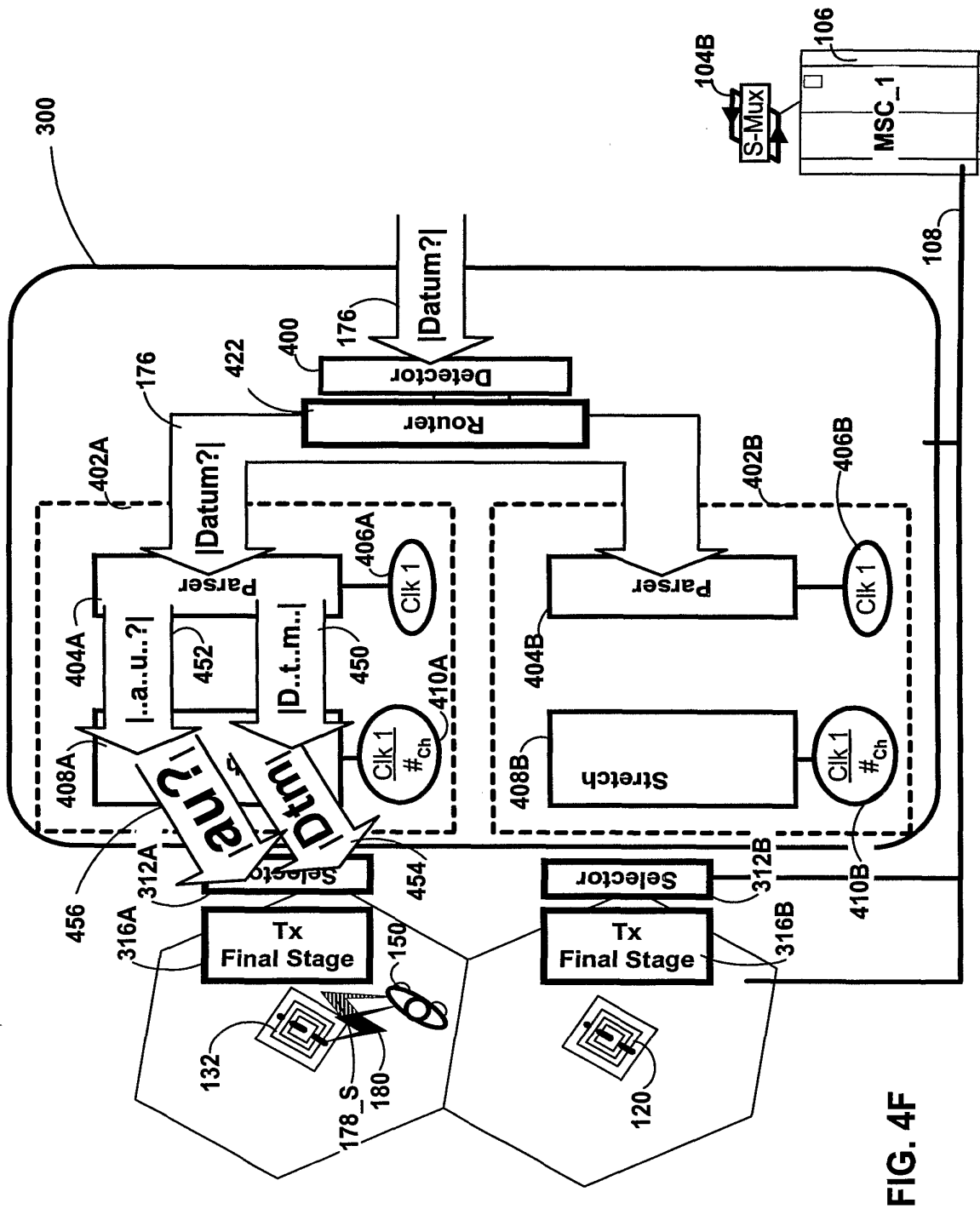


FIG. 4F

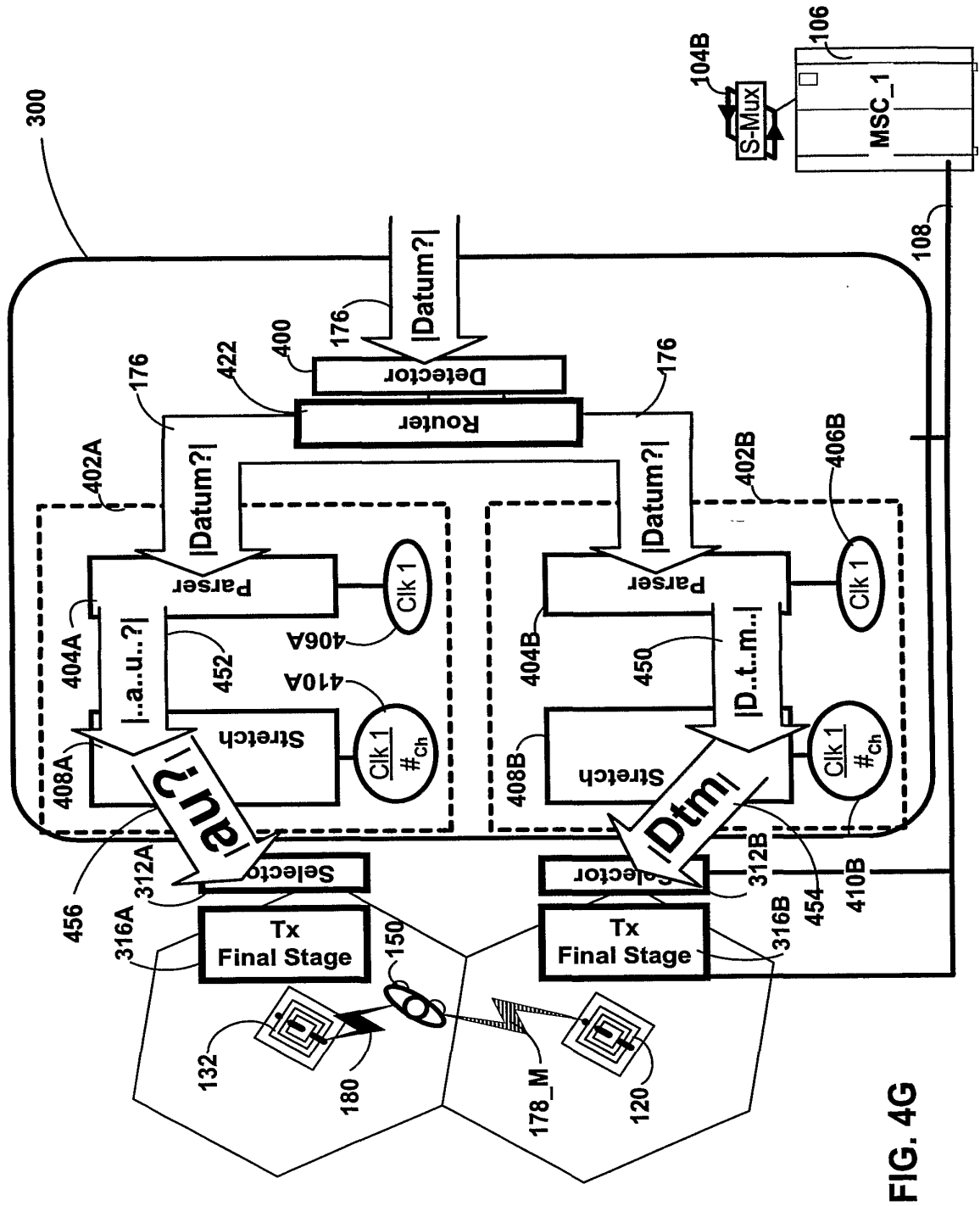


FIG. 4G

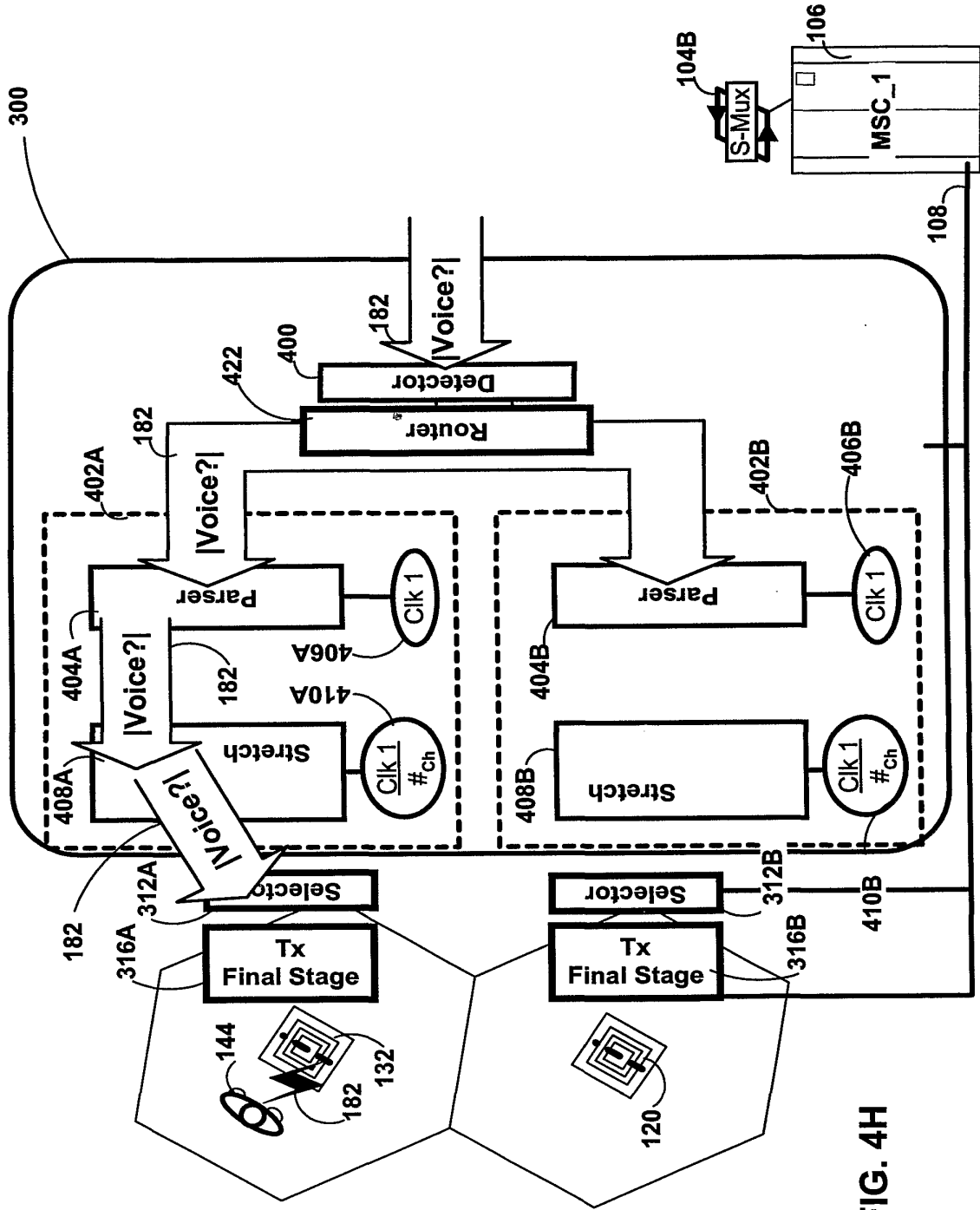


FIG. 4H

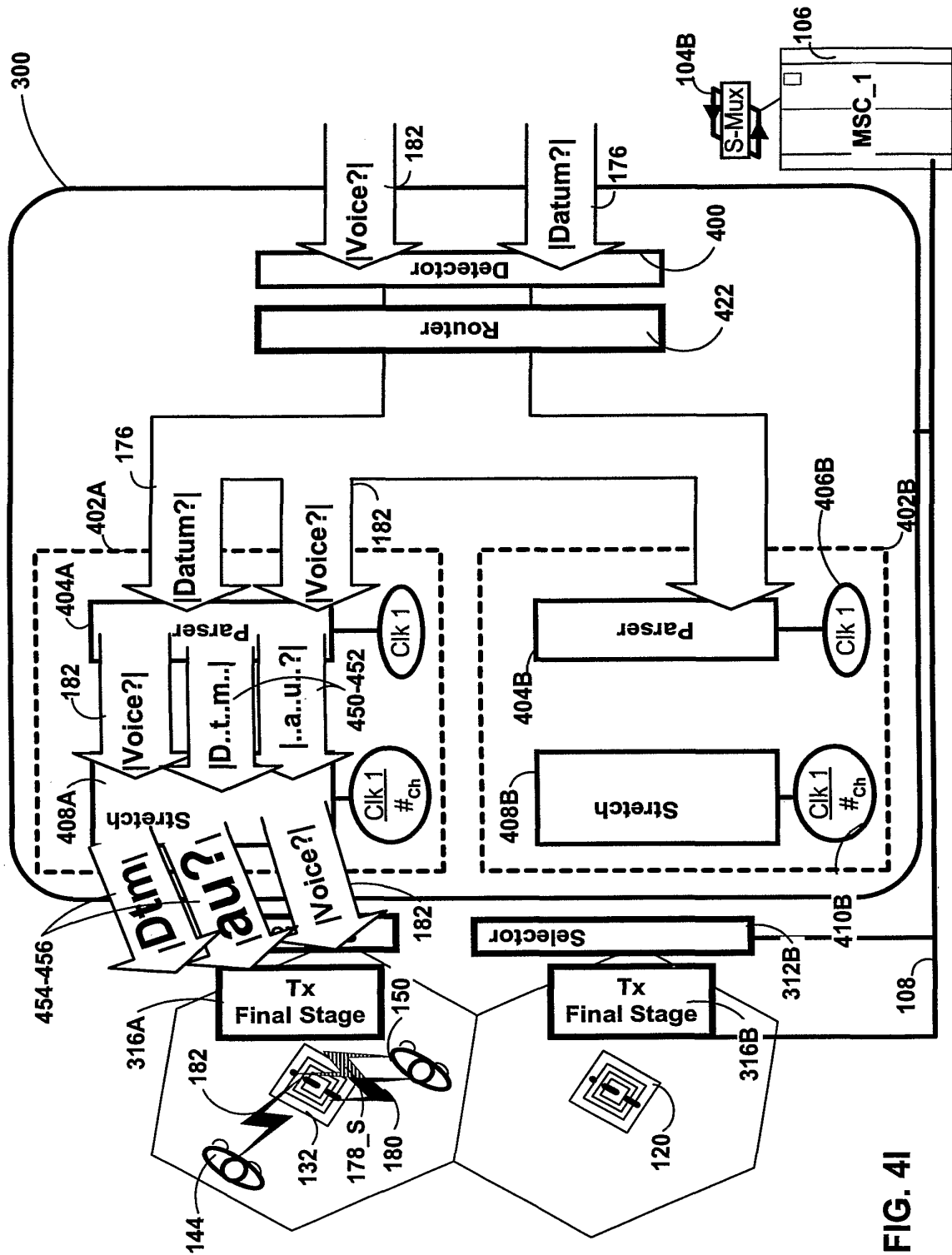


FIG. 4I

SUBSTITUTE SHEET (RULE 26)



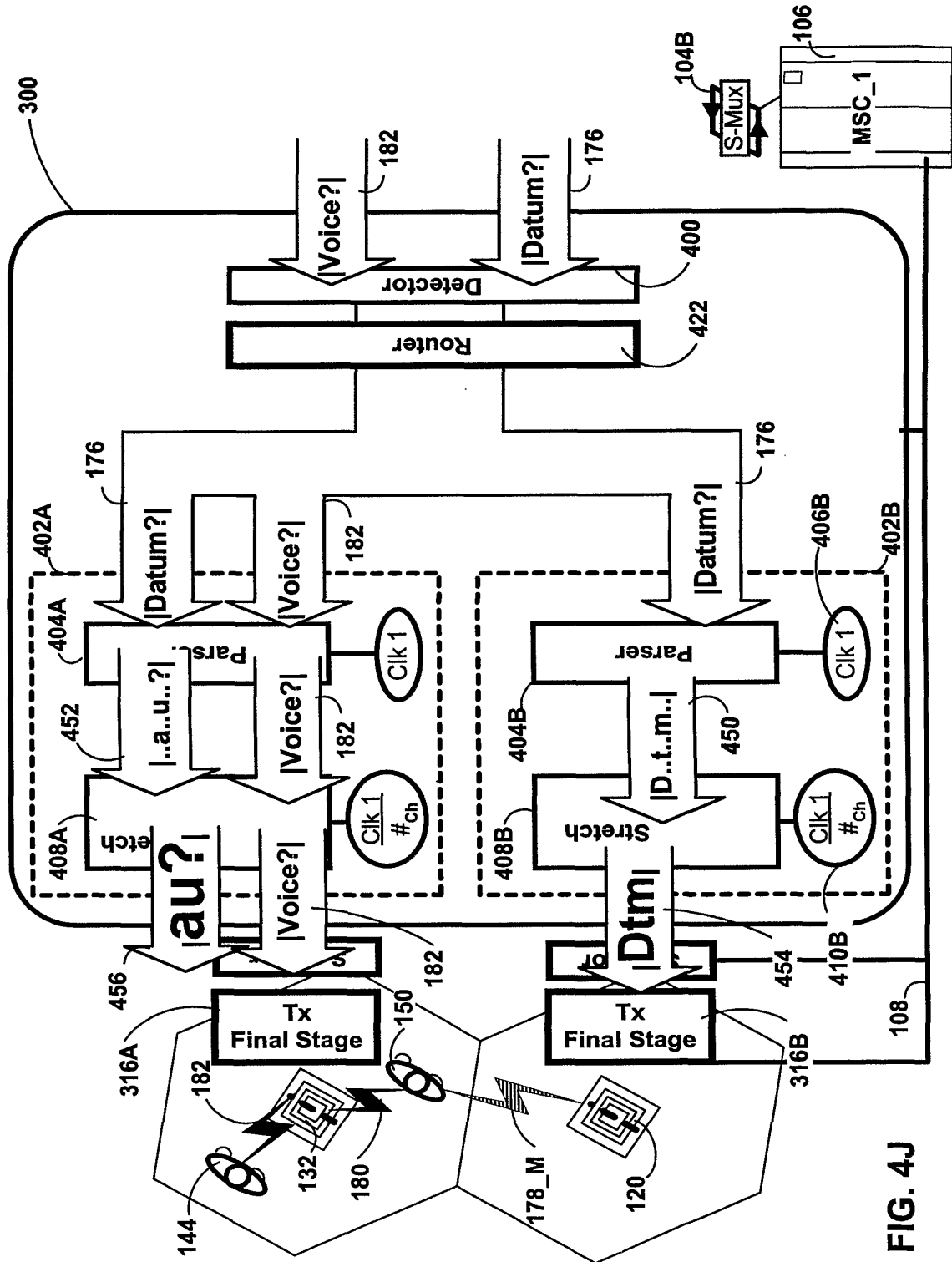


FIG. 4J



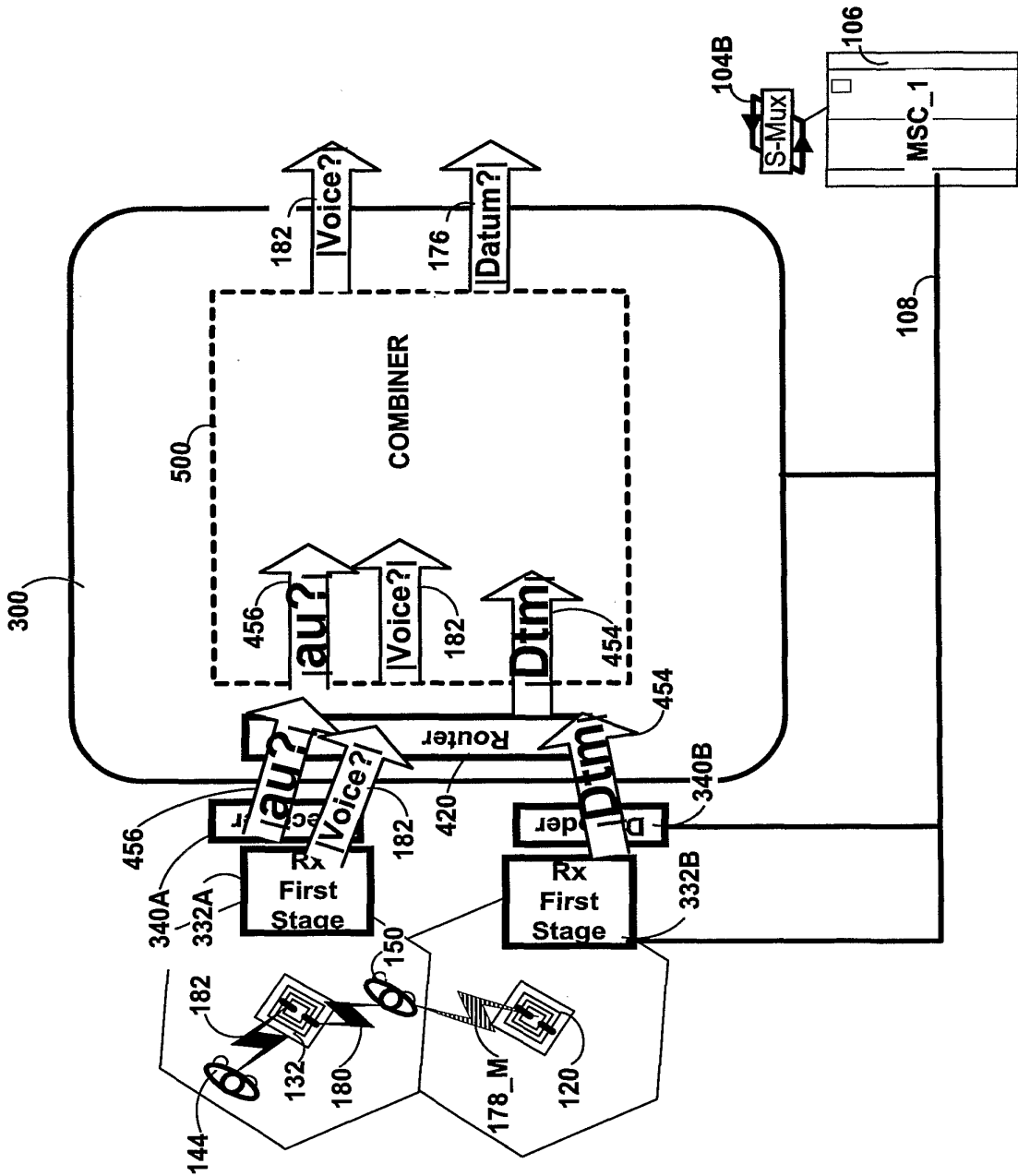
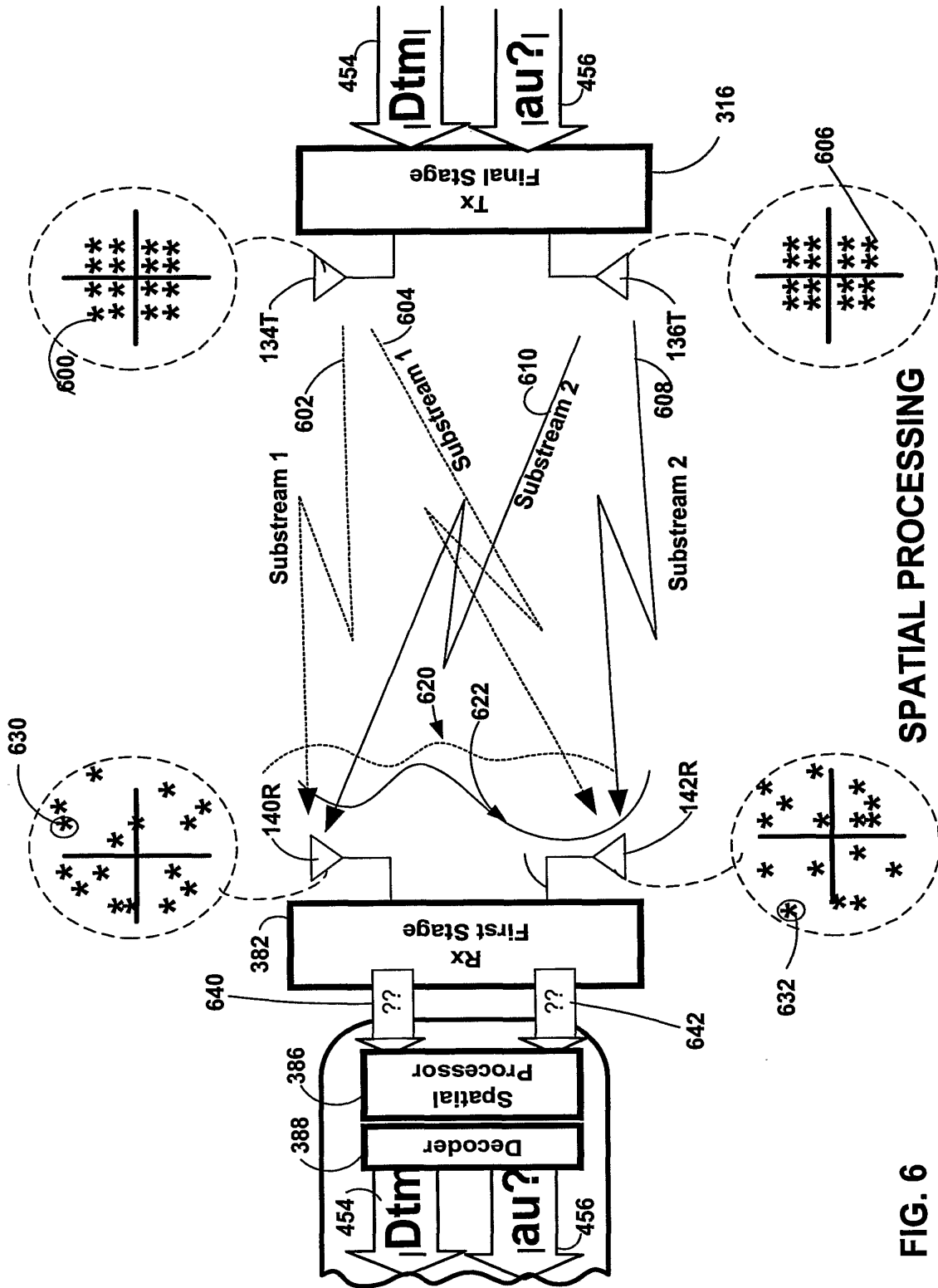


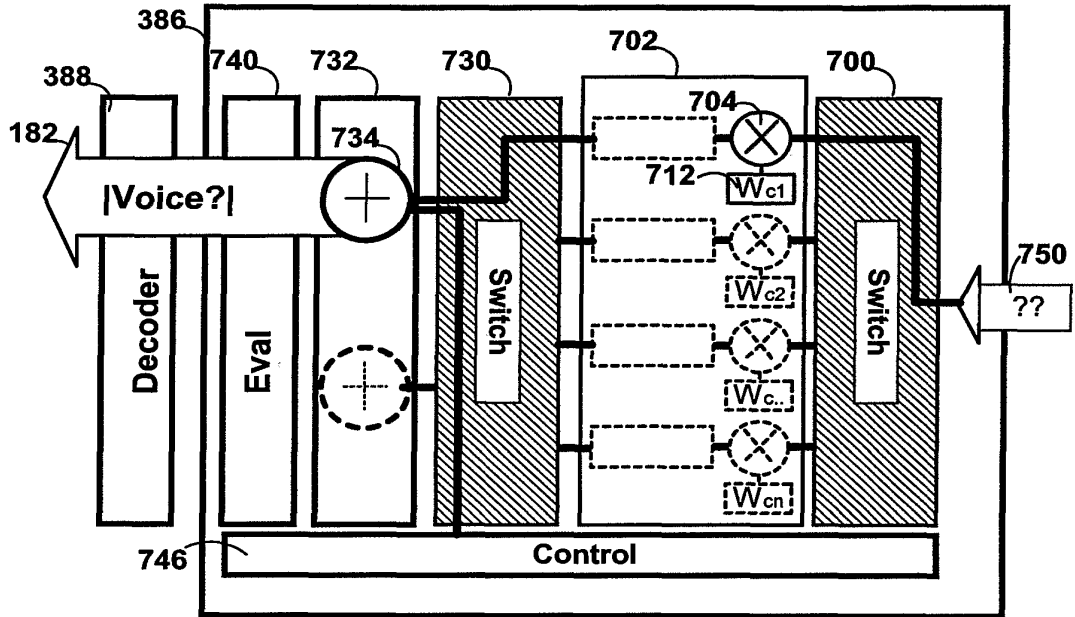
FIG. 5B



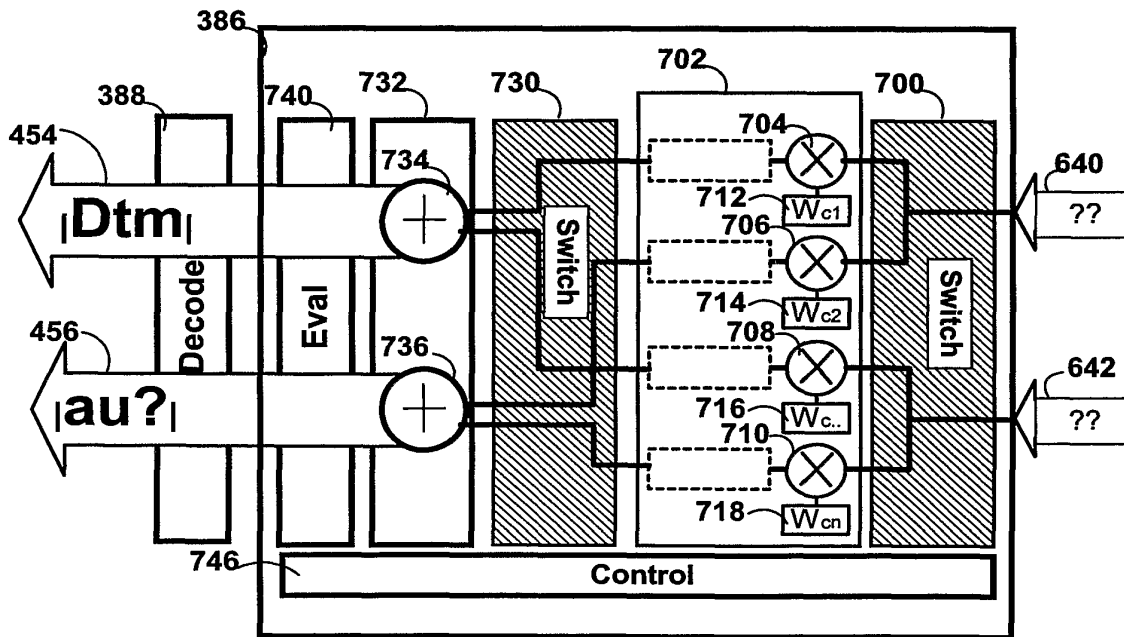
**SPATIAL PROCESSING**

**FIG. 6**

SUBSTITUTE SHEET (RULE 26)

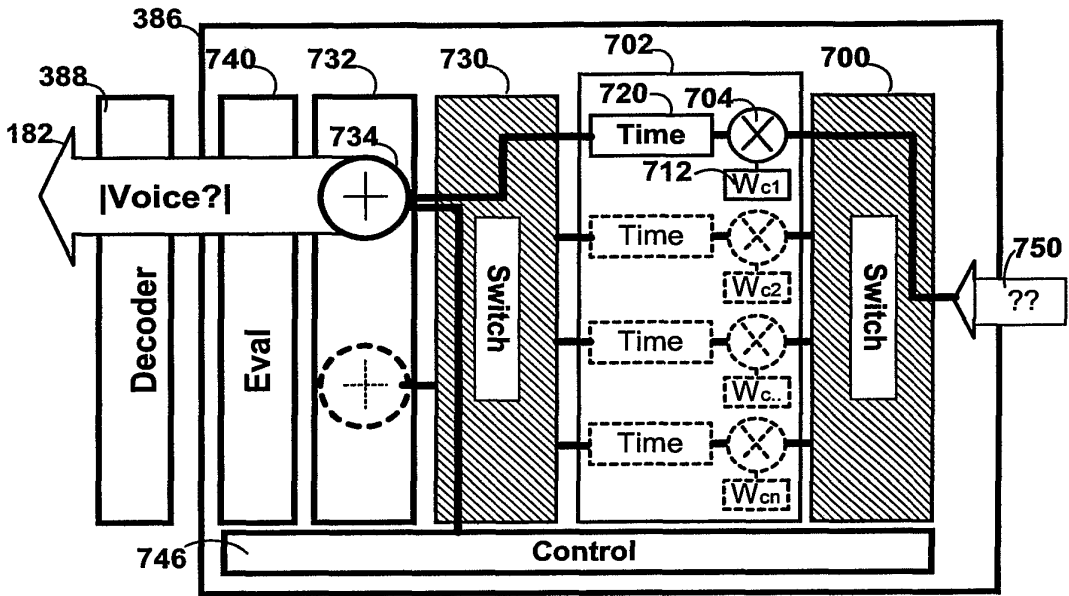


Spatial Processor FIG. 7A



Spatial Processor

FIG. 7B



Space-Time Processor FIG. 7C

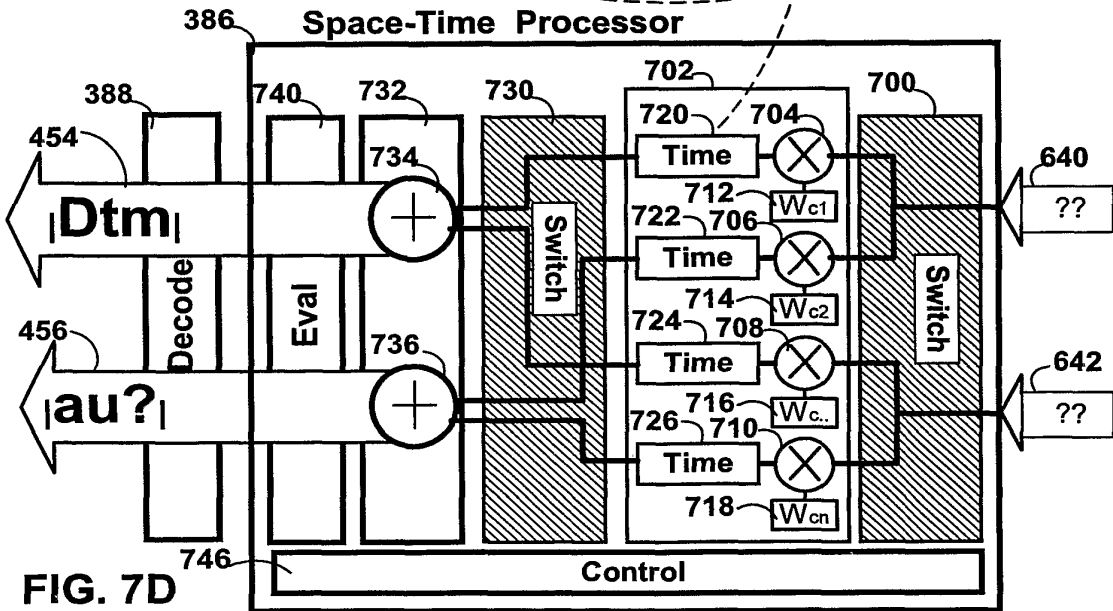
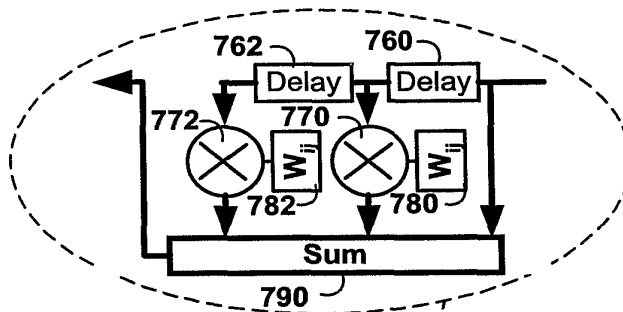


FIG. 7D

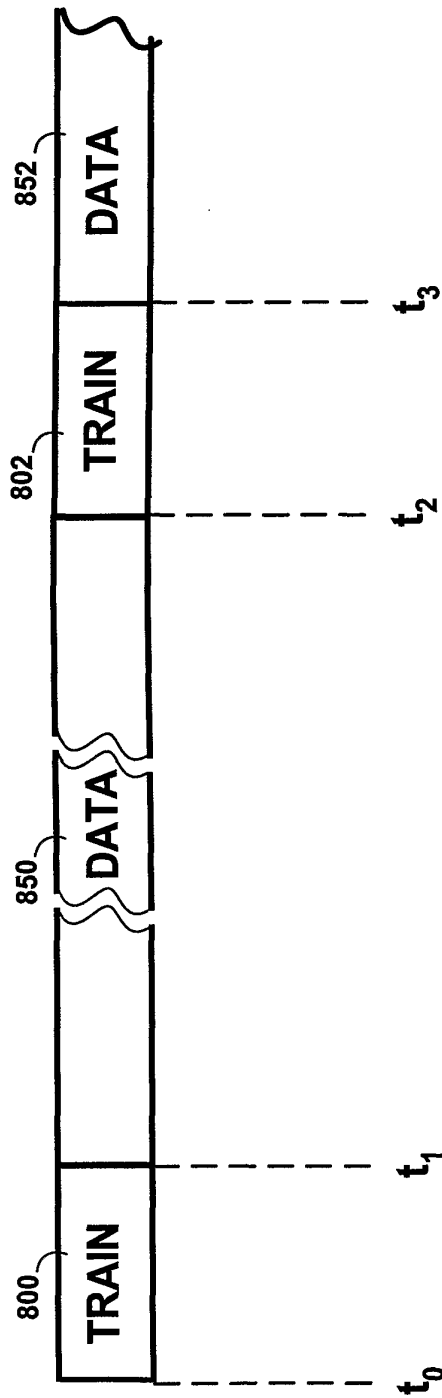
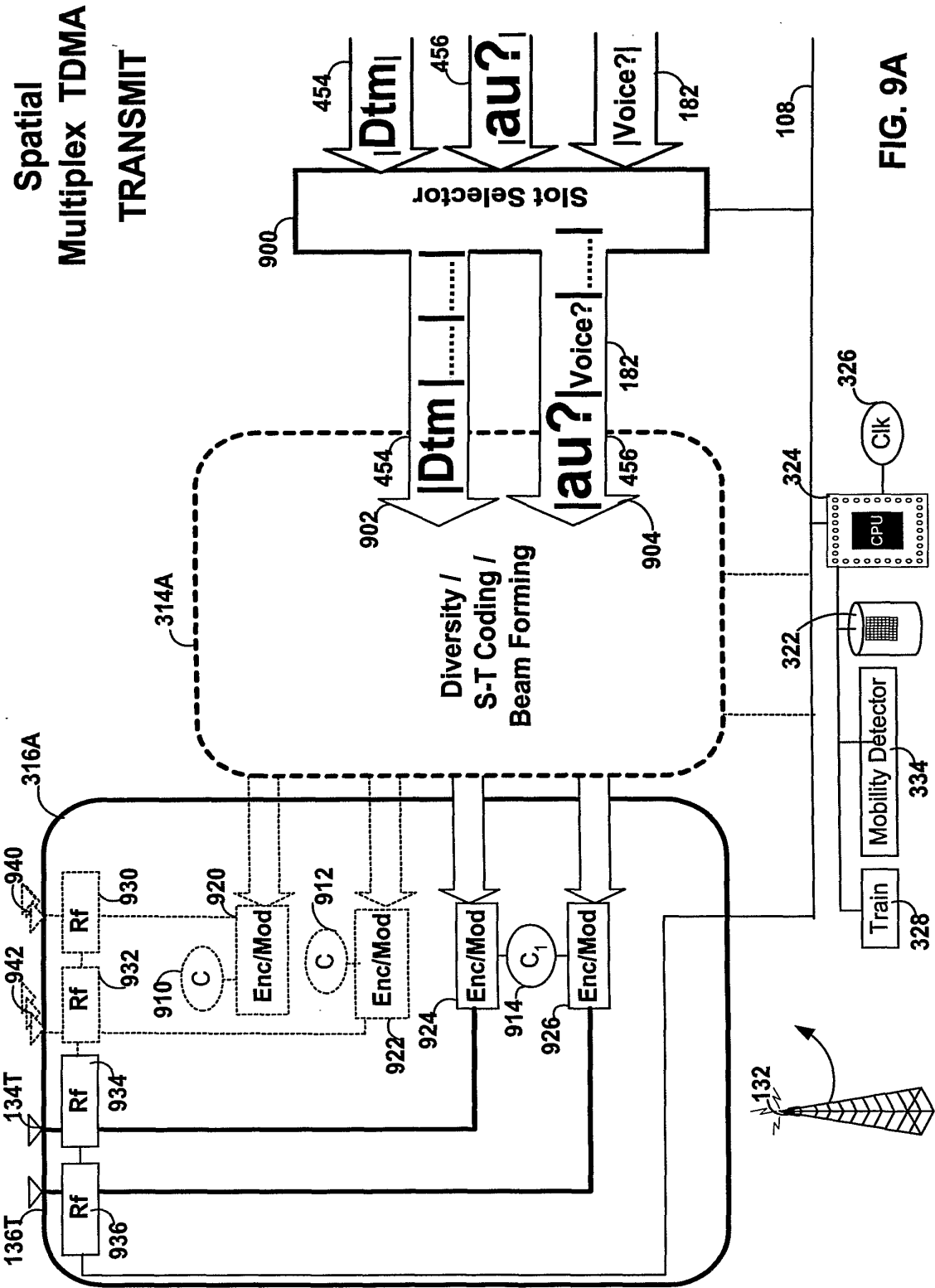
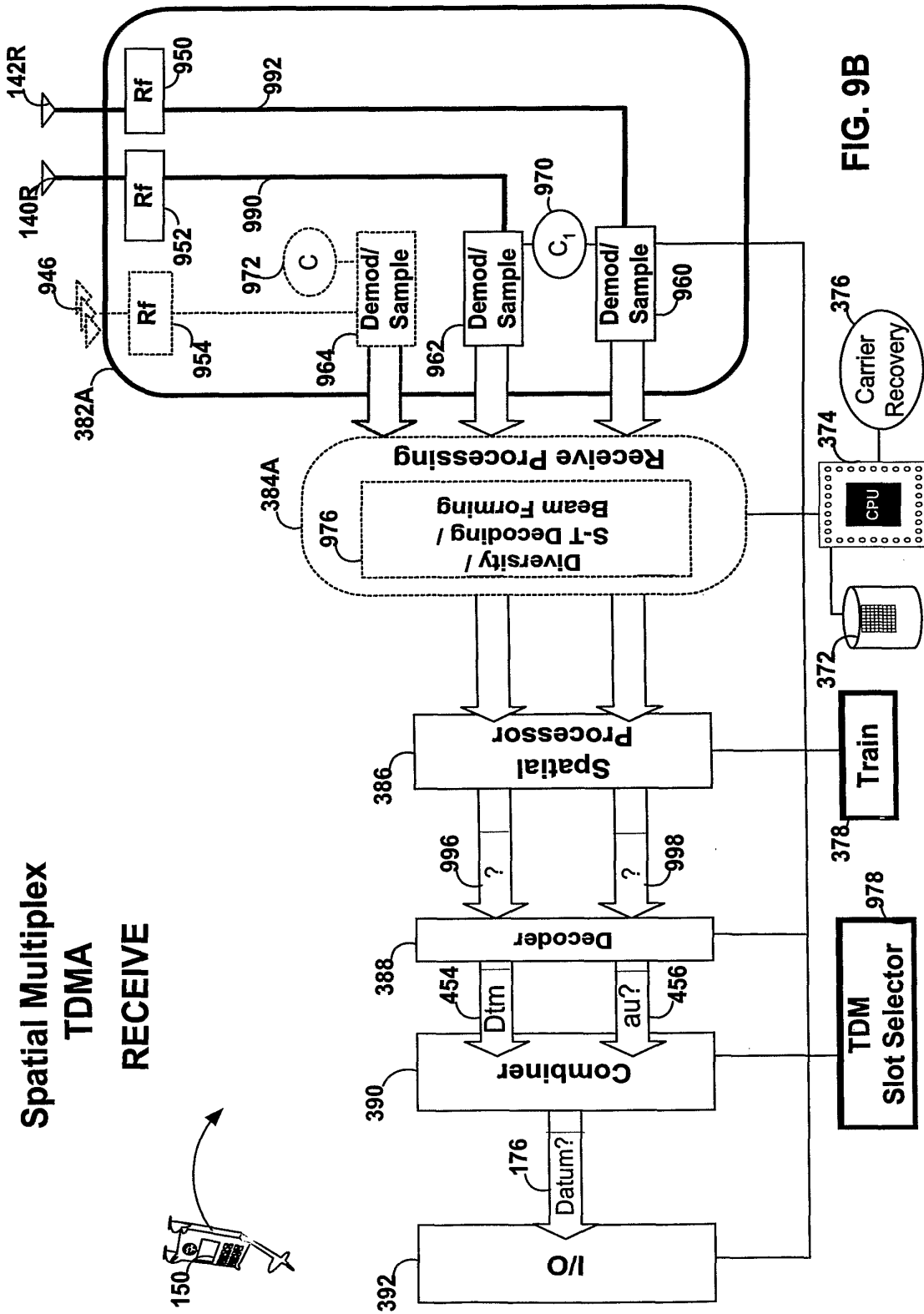


FIG. 8



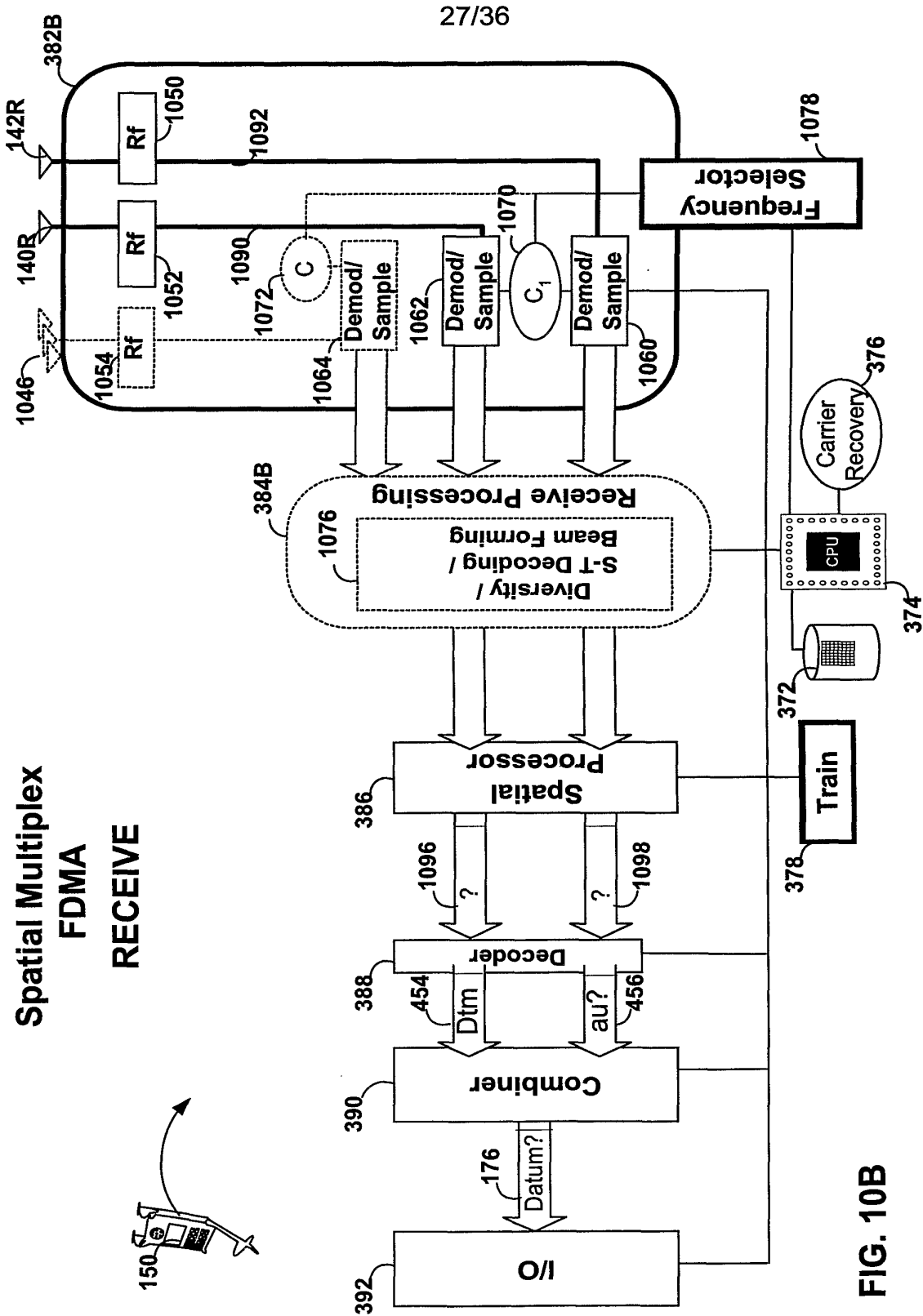
SUBSTITUTE SHEET (RULE 26)





SUBSTITUTE SHEET (RULE 26)





SUBSTITUTE SHEET (RULE 26)

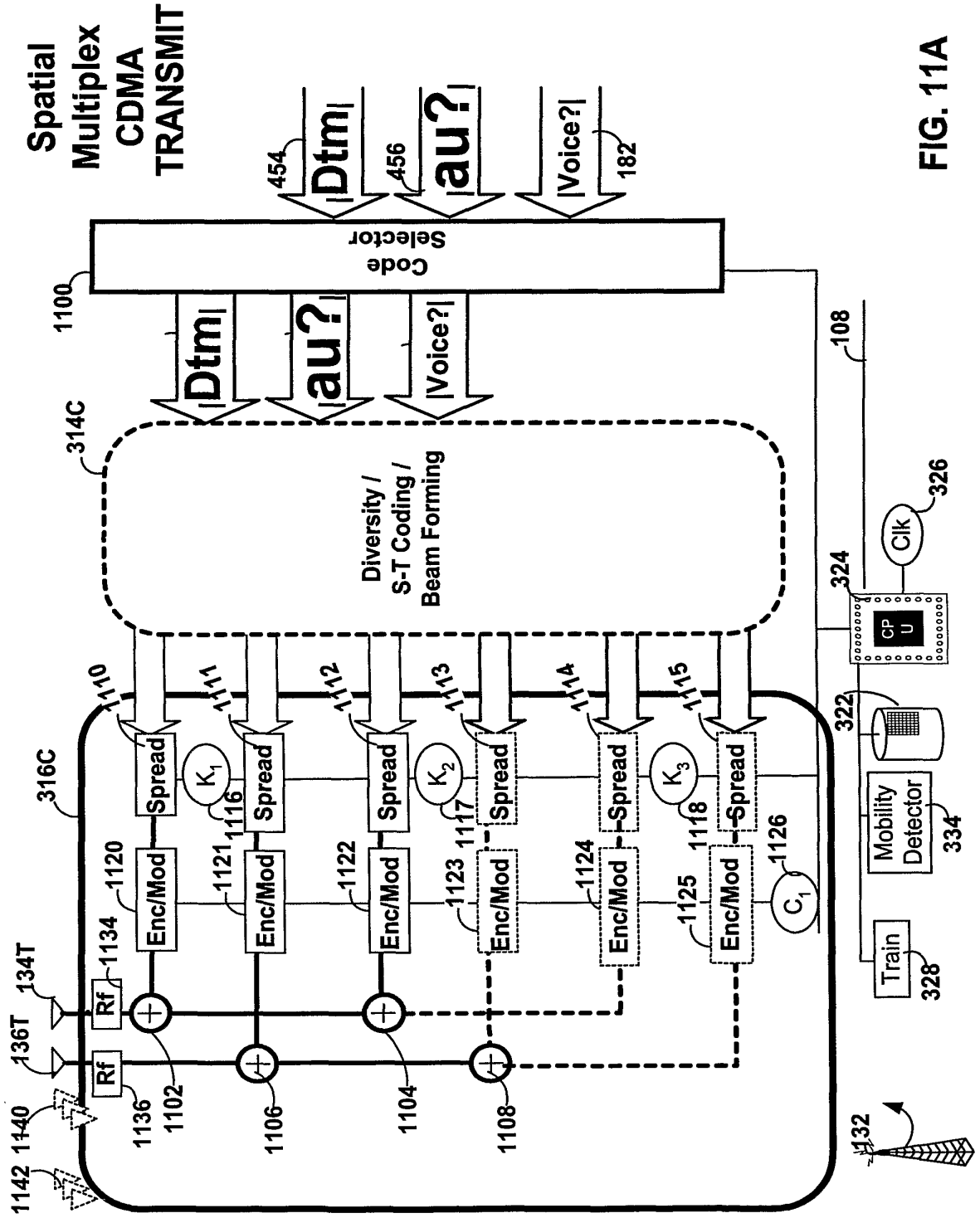


FIG. 11A

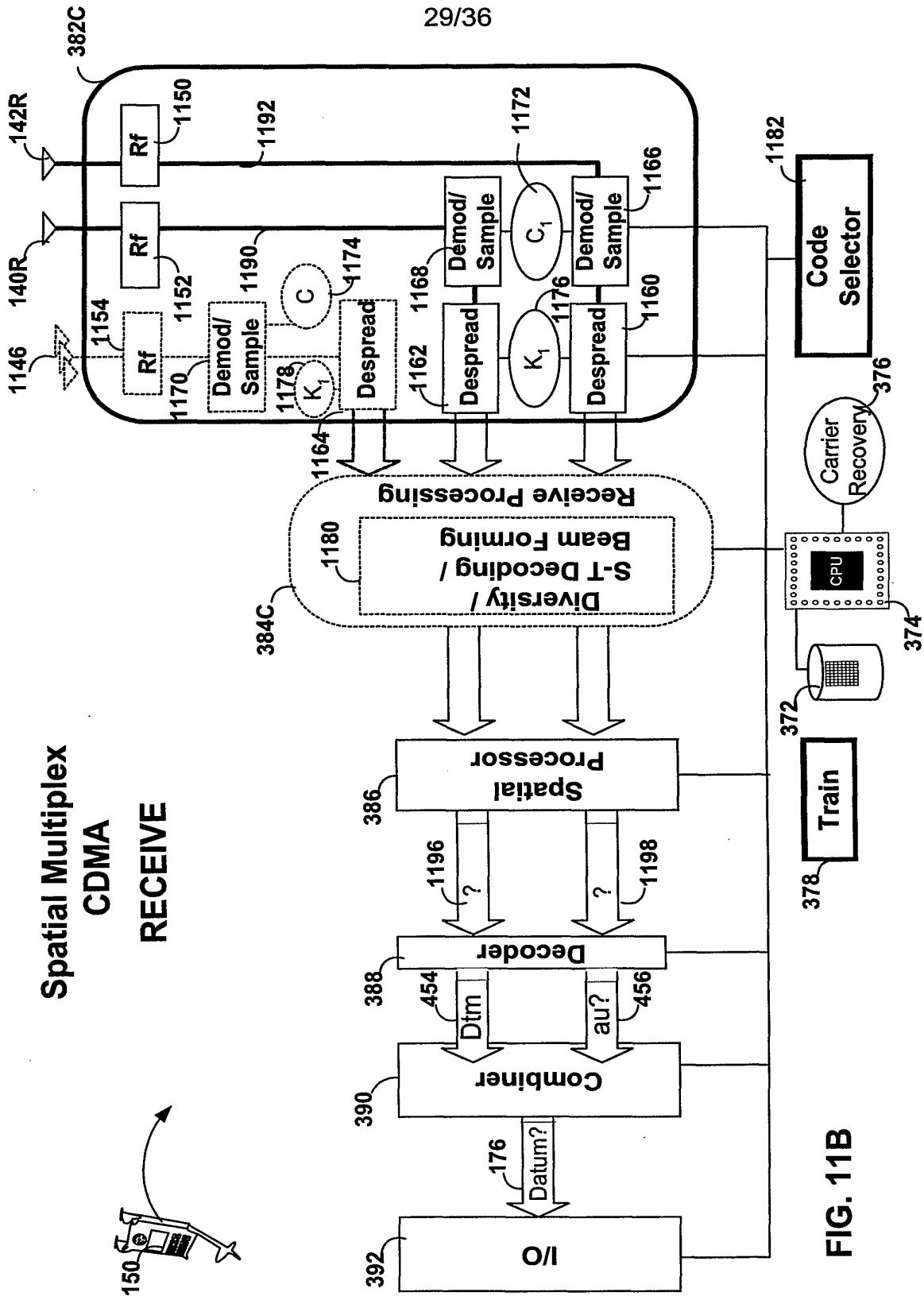
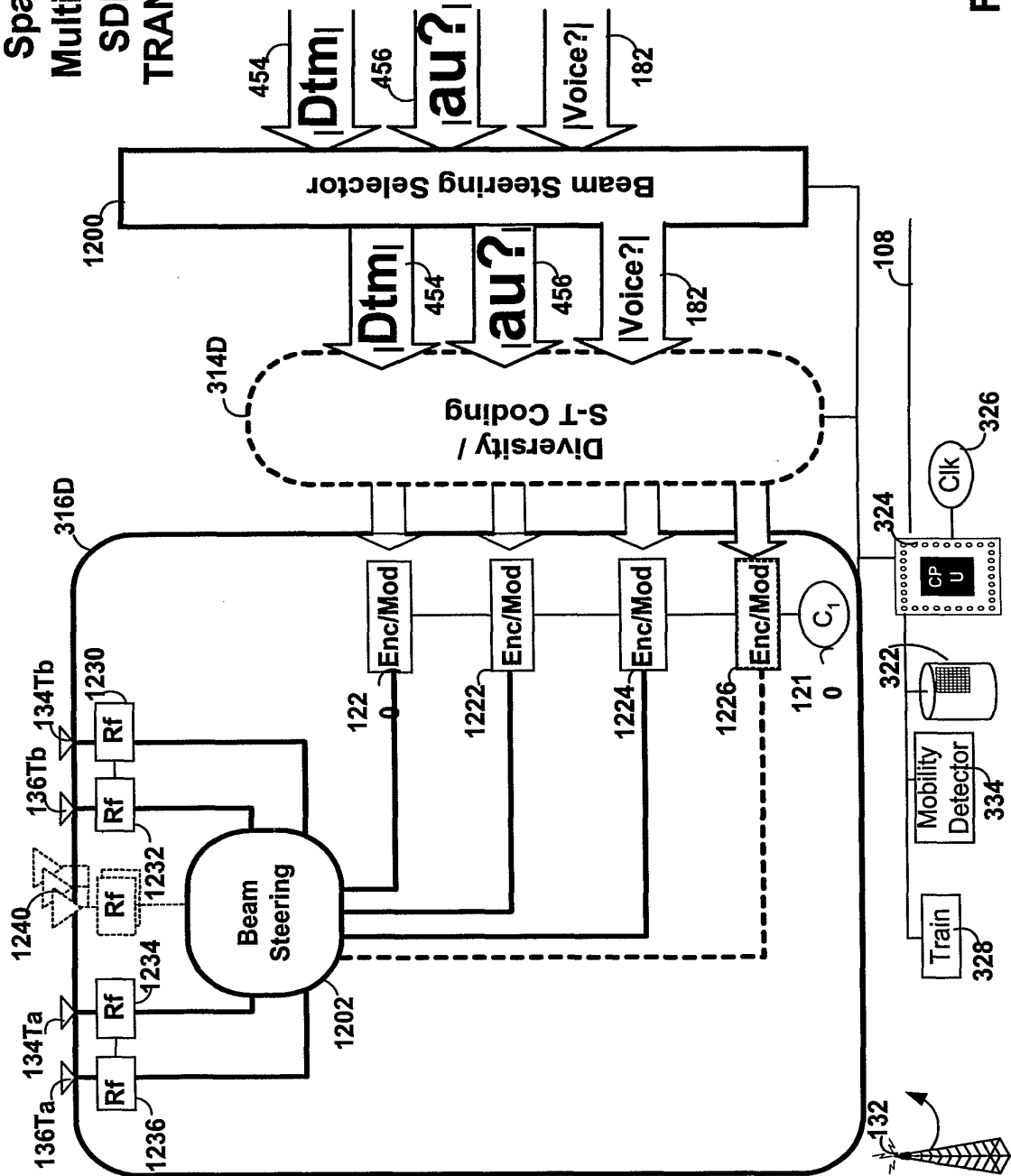
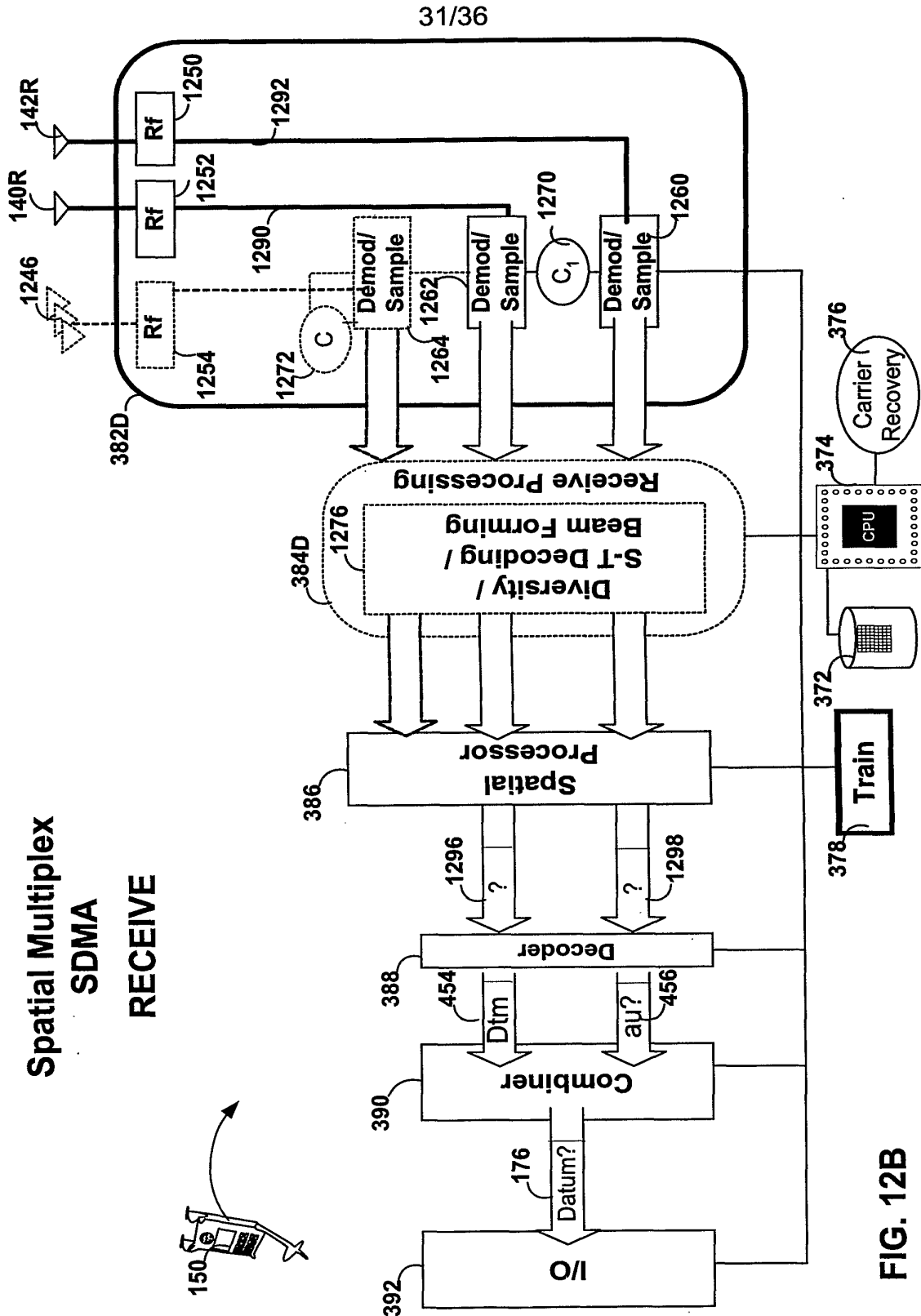


FIG. 11B

**Spatial  
Multiplex  
SDMA  
TRANSMIT**



**FIG. 12A**



**FIG. 12B**

SUBSTITUTE SHEET (RULE 26)

FIG. 13A

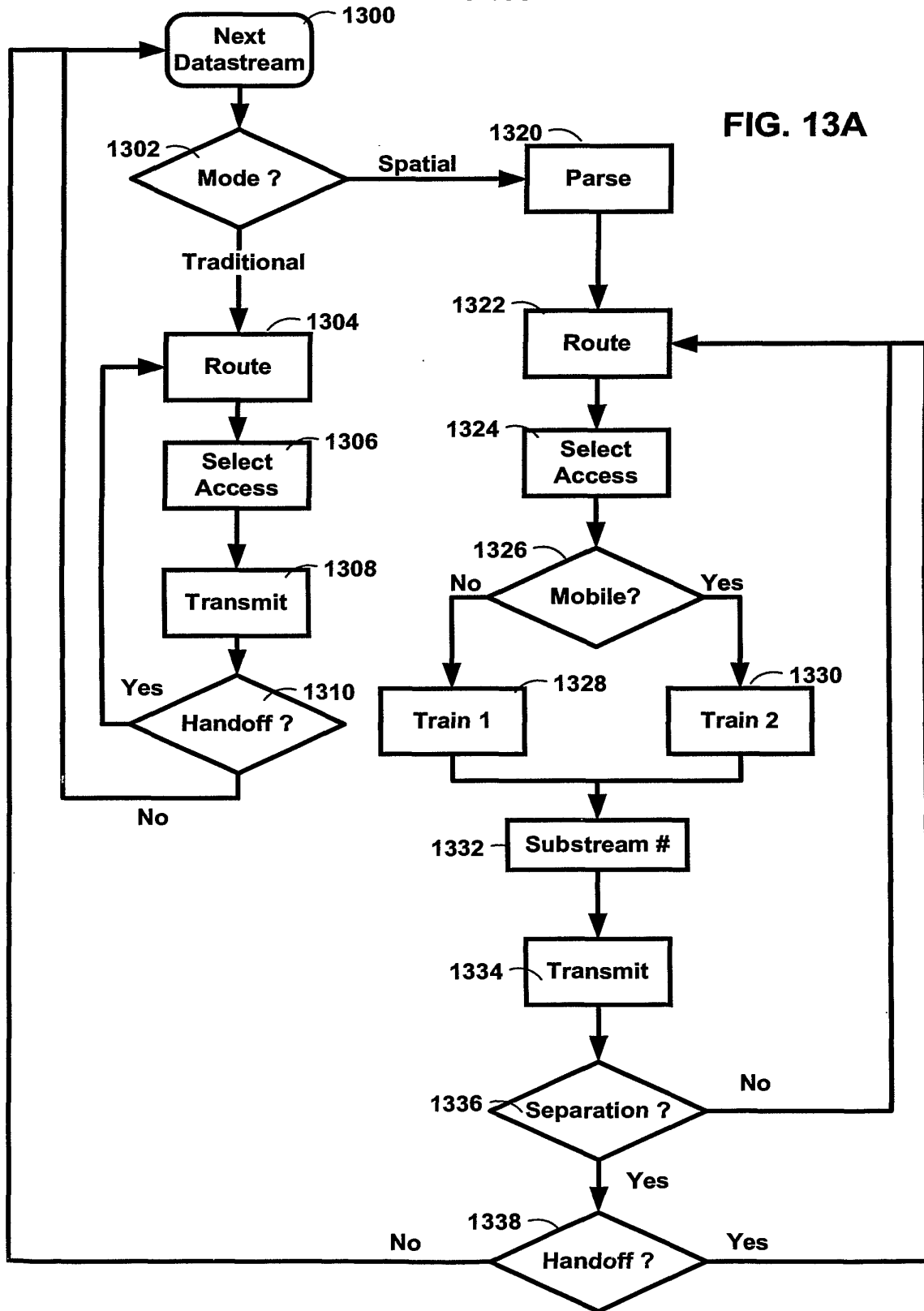
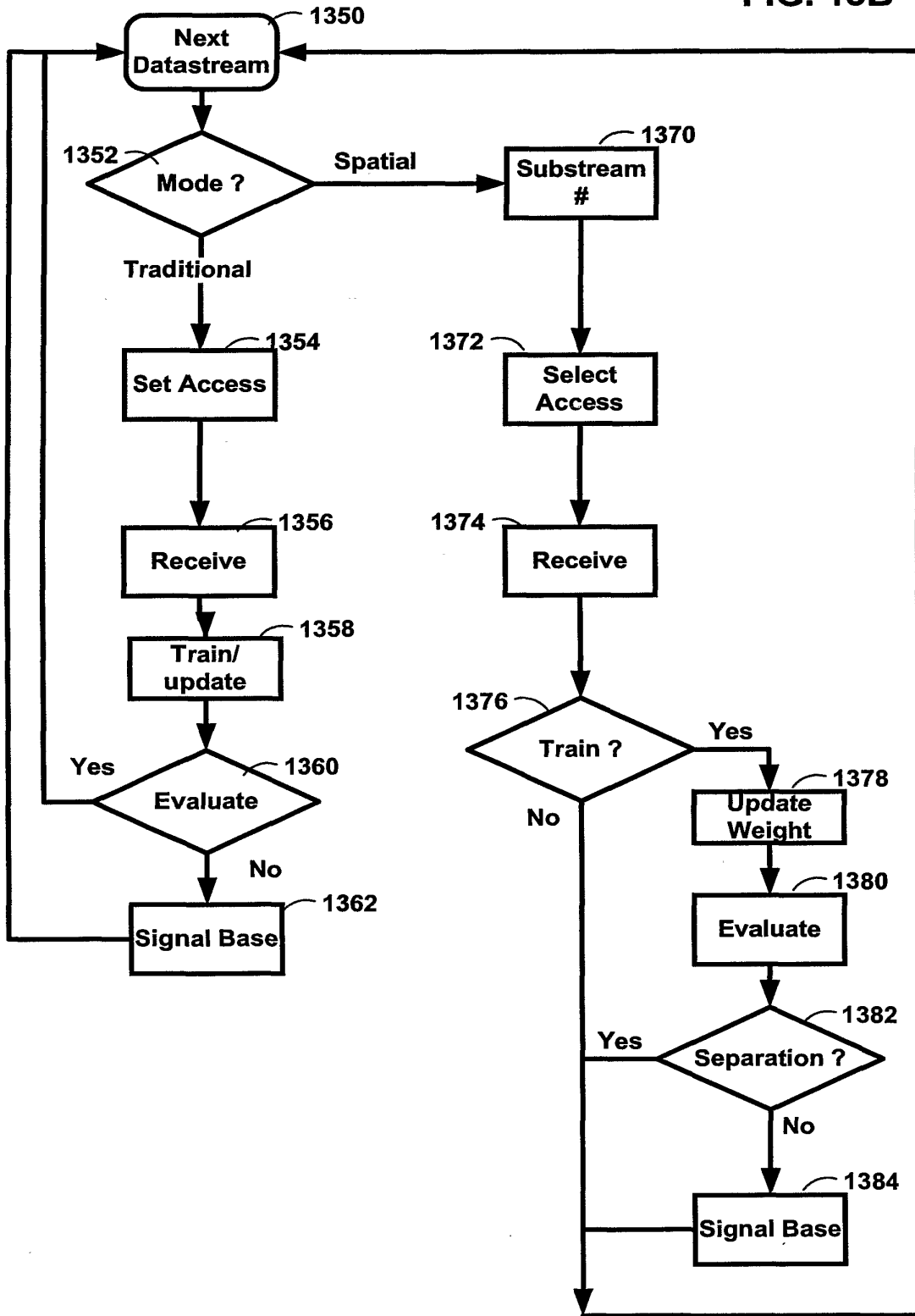




FIG. 13B



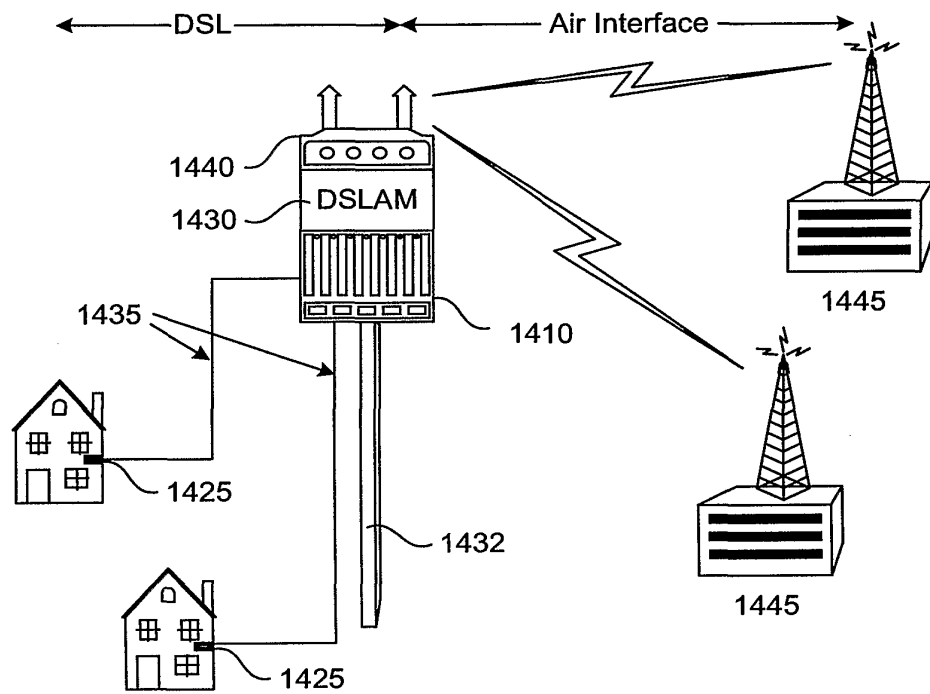


FIG. 14

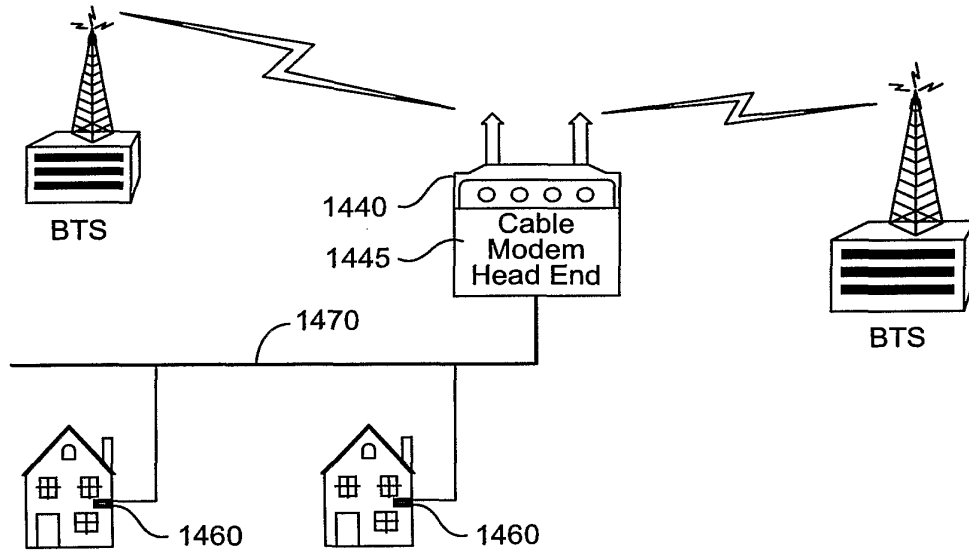


FIG. 15

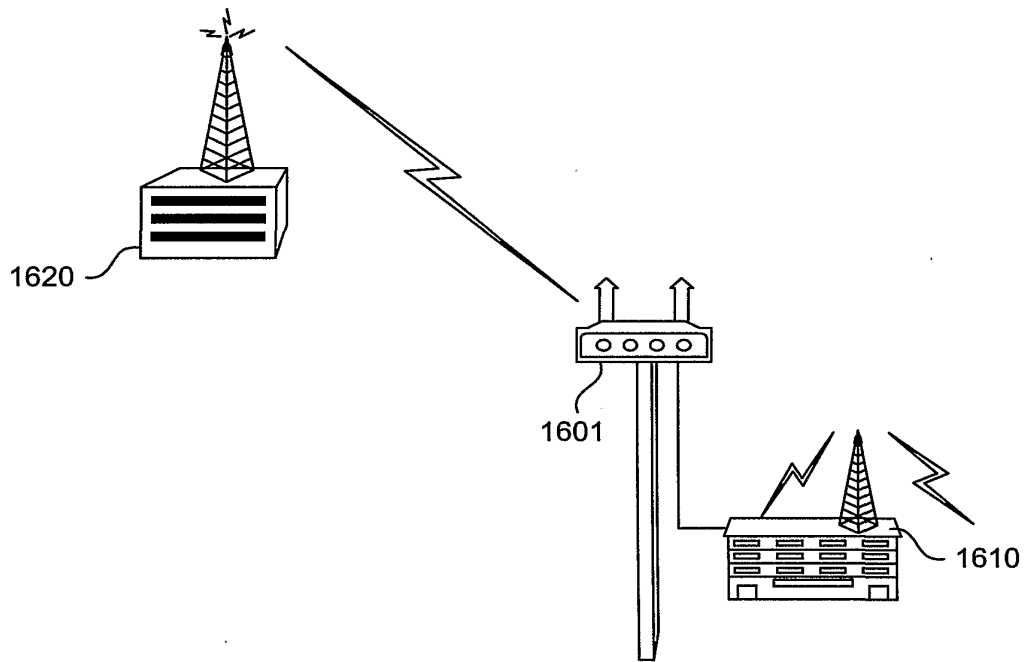


FIG. 16

INTERNATIONAL SEARCH REPORT

International Application No  
PCT/US 00/20706

<b>A. CLASSIFICATION OF SUBJECT MATTER</b> IPC 7 H04Q7/36 H04B7/005		
According to International Patent Classification (IPC) or to both national classification and IPC		
<b>B. FIELDS SEARCHED</b>		
Minimum documentation searched (classification system followed by classification symbols) IPC 7 H04Q H04B		
Documentation searched other than minimum documentation to the extent that such documents are included in the fields searched		
Electronic data base consulted during the international search (name of data base and, where practical, search terms used) EPO-Internal, INSPEC		
<b>C. DOCUMENTS CONSIDERED TO BE RELEVANT</b>		
Category °	Citation of document, with indication, where appropriate, of the relevant passages	Relevant to claim No.
X	PAULRAJ A J ET AL: "TAXONOMY OF SPACE-TIME PROCESSING FOR WIRELESS NETWORKS" IEE PROCEEDINGS: RADAR, SONAR & NAVIGATION, GB, INSTITUTION OF ELECTRICAL ENGINEERS, vol. 145, no. 1, 1 February 1998 (1998-02-01), pages 25-31, XP000769921 ISSN: 1350-2395 page 25, paragraph 2.1 -page 26 page 26, paragraph 2.2.2 -page 27 page 27, paragraph 3.1 page 28, column 1	1-76
<input checked="" type="checkbox"/> Further documents are listed in the continuation of box C.		
<input checked="" type="checkbox"/> Patent family members are listed in annex.		
° Special categories of cited documents :		
"A" document defining the general state of the art which is not considered to be of particular relevance "E" earlier document but published on or after the international filing date "L" document which may throw doubts on priority claim(s) or which is cited to establish the publication date of another citation or other special reason (as specified) "O" document referring to an oral disclosure, use, exhibition or other means "P" document published prior to the international filing date but later than the priority date claimed		"T" later document published after the international filing date or priority date and not in conflict with the application but cited to understand the principle or theory underlying the invention "X" document of particular relevance; the claimed invention cannot be considered novel or cannot be considered to involve an inventive step when the document is taken alone "Y" document of particular relevance; the claimed invention cannot be considered to involve an inventive step when the document is combined with one or more other such documents, such combination being obvious to a person skilled in the art. "&" document member of the same patent family
Date of the actual completion of the international search 18 October 2000		Date of mailing of the international search report 25/10/2000
Name and mailing address of the ISA European Patent Office, P.B. 5818 Patentlaan 2 NL - 2280 HV Rijswijk Tel. (+31-70) 340-2040, Tx. 31 651 epo nl, Fax: (+31-70) 340-3016		Authorized officer Dheere, R

Form PCT/ISA/210 (second sheet) (July 1992)

INTERNATIONAL SEARCH REPORT

International Application No  
PCT/US 00/20706

C.(Continuation) DOCUMENTS CONSIDERED TO BE RELEVANT		
Category *	Citation of document, with indication, where appropriate, of the relevant passages	Relevant to claim No.
X	<p>WO 98 09381 A (RALEIGH)                      5 March 1998 (1998-03-05)                      page 1, line 14 - line 18                      page 2, line 5 -page 3, line 6                      page 6, line 5 - line 25                      page 7, line 2 - line 17                      page 9, line 22 - line 35                      page 10                      page 11                      page 15, line 5 - line 24                      page 19, line 5 -page 20, line 15                      figure 5A</p>	1-76
A	<p>WO 98 34424 A (AT&amp;T)                      6 August 1998 (1998-08-06)</p> <p>page 3, line 8 - line 13                      page 5, line 17 - line 21</p>	1, 18, 26, 27, 29, 34, 41, 43-45, 54, 56, 58-60, 62-67, 69, 70
A	<p>US 5 592 490 A (ARRAYCOMM)                      7 January 1997 (1997-01-07)</p> <p>column 11, line 10 - line 15                      abstract                      figure 1</p>	1, 18, 26, 27, 29, 34, 41, 43-45, 54, 56, 58-60, 62-67, 69, 70
P, X	<p>US 6 067 290 A (GIGABIT WIRELESS)                      23 May 2000 (2000-05-23)                      the whole document</p>	1-76

## INTERNATIONAL SEARCH REPORT

 International Application No  
 PCT/US 00/20706

Patent document cited in search report	Publication date	Patent family member(s)	Publication date
WO 9809381 A	05-03-1998	AU 4238697 A	19-03-1998
		EP 0920738 A	09-06-1999
		EP 0931388 A	28-07-1999
		WO 9809385 A	05-03-1998
		WO 9809395 A	05-03-1998
WO 9834424 A	06-08-1998	US 6052599 A	18-04-2000
		EP 0956722 A	17-11-1999
US 5592490 A	07-01-1997	US 5515378 A	07-05-1996
		US 5546090 A	13-08-1996
		AU 701764 B	04-02-1999
		AU 4595296 A	07-08-1996
		BR 9510197 A	23-12-1997
		CA 2210859 A	25-07-1996
		CN 1173265 A	11-02-1998
		EP 0804858 A	05-11-1997
		FI 973076 A	16-09-1997
		JP 11504169 T	06-04-1999
		WO 9622662 A	25-07-1996
		WO 9818272 A	30-04-1998
		US 5828658 A	27-10-1998
		AT 183865 T	15-09-1999
		AU 670766 B	01-08-1996
		AU 3145493 A	19-07-1993
		CA 2125571 A	24-06-1993
		DE 69229876 D	30-09-1999
		DE 69229876 T	30-12-1999
		EP 0616742 A	28-09-1994
		EP 0926916 A	30-06-1999
		ES 2137197 T	16-12-1999
		FI 942771 A	10-06-1994
JP 7505017 T	01-06-1995		
WO 9312590 A	24-06-1993		
US 5625880 A	29-04-1997		
US 5642353 A	24-06-1997		
US 6067290 A	23-05-2000	NONE	

Form PCT/ISA/210 (patent family annex) (July 1992)

(12) INTERNATIONAL APPLICATION PUBLISHED UNDER THE PATENT COOPERATION TREATY (PCT)

(19) World Intellectual Property Organization  
International Bureau



(43) International Publication Date  
12 September 2003 (12.09.2003)

PCT

(10) International Publication Number  
WO 03/075396 A2

(51) International Patent Classification<sup>7</sup>: H01Q

L. [US/US]; 15307C Diamond Cove Terrace, Rockville, MD 20850 (US). VAIDYANATHAN, Chandra [IN/US]; 10411 Montrose Avenue, #202, Bethesda, MD 20814 (US). TESFAI, Yohannes [ER/US]; 2230 George C. Marshall Drive, Apartment 104, Falls Church, VA 22043 (US).

(21) International Application Number: PCT/US03/05642

(22) International Filing Date: 26 February 2003 (26.02.2003)

(25) Filing Language: English

(26) Publication Language: English

(74) Agent: FLOAM, D., Andrew; Cognio, Inc., 101 Orchard Ridge Drive, Suite 350, Gaithersburg, MA 20878 (US).

(30) Priority Data:  
60/361,055 1 March 2002 (01.03.2002) US  
60/365,797 21 March 2002 (21.03.2002) US  
10/174,728 19 June 2002 (19.06.2002) US

(81) Designated States (national): AE, AG, AL, AM, AT, AU, AZ, BA, BB, BG, BR, BY, BZ, CA, CH, CN, CO, CR, CU, CZ, DE, DK, DM, DZ, EC, EE, ES, FI, GB, GD, GE, GH, GM, HR, HU, ID, IL, IN, IS, JP, KE, KG, KP, KR, KZ, LC, LK, LR, LS, LT, LU, LV, MA, MD, MG, MK, MN, MW, MX, MZ, NO, NZ, OM, PH, PL, PT, RO, RU, SD, SE, SG, SK, SL, TJ, TM, TN, TR, TT, TZ, UA, UG, US, UZ, VN, YU, ZA, ZM, ZW.

(63) Related by continuation (CON) or continuation-in-part (CIP) to earlier application:  
US 10/174,728 (CIP)  
Filed on 19 June 2002 (19.06.2002)

(71) Applicant (for all designated States except US):  
COGNIO, INC. [US/US]; 101 Orchard Ridge Drive, Suite 350, Gaithersburg, MD 20878 (US).

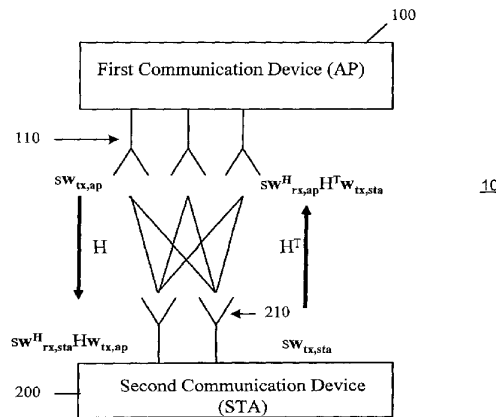
(84) Designated States (regional): ARIPO patent (GH, GM, KE, LS, MW, MZ, SD, SL, SZ, TZ, UG, ZM, ZW), Eurasian patent (AM, AZ, BY, KG, KZ, MD, RU, TJ, TM), European patent (AT, BE, BG, CH, CY, CZ, DE, DK, EE, ES, FI, FR, GB, GR, HU, IE, IT, LU, MC, NL, PT, SE, SI,

(72) Inventors; and

(75) Inventors/Applicants (for US only): SUGAR, Gary,

[Continued on next page]

(54) Title: SYSTEM AND METHOD FOR ANTENNA DIVERSITY USING JOINT MAXIMAL RATIO COMBINING



(57) Abstract: A composite beamforming technique is provided wherein a first communication device has a plurality of antennas and the second communication has a plurality of antennas. When the first communication device transmits to the second communication device, the transmit signal is multiplied by a transmit weight vector for transmission by each of the plurality of antennas and the transmit signals are received by the plurality of antennas at the second communication device. The second communication device determines the best receive weight vector for the its antennas, and from that vector, derives a suitable transmit weight vector for transmission on the plurality of antennas back to the first communication device. Several techniques are provided to determine the optimum transmit weight vector and receive weight vector for communication between the first and second communication devices so that there is effectively joint or composite beamforming between the communication devices.

WO 03/075396 A2





SK, TR), OAPI patent (BF, BJ, CF, CG, CI, CM, GA, GN, GQ, GW, ML, MR, NE, SN, TD, TG).

*For two-letter codes and other abbreviations, refer to the "Guidance Notes on Codes and Abbreviations" appearing at the beginning of each regular issue of the PCT Gazette.*

**Published:**

— *without international search report and to be republished upon receipt of that report*



(CBF) is a multiple-input multiple-output (MIMO) antenna scheme that uses antenna signal processing at both ends of the communication link to maximize the signal-to-noise (SNR) and/or signal-to-noise-plus-interference (SNIR), thereby improving the link margin between two communication devices, as well as to provide for other advantages described herein.

Generally, a first communication device has a plurality of antennas and the second communication has a plurality of antennas. The first communication device transmits to the second communication device using a transmit weight vector for transmission by each the plurality of antennas and the transmit signals are received by the plurality of antennas at the second communication device. The second communication device determines the receive weight vector for its antennas, and from that vector, derives a suitable transmit weight vector for transmission on the plurality of antennas back to the first communication device. Several techniques are provided to determine the optimum frequency dependent transmit weight vector and receive weight vector across the bandwidth of a baseband signal transmitted between the first and second communication devices so that there is effectively joint or composite beamforming between the communication devices. The link margin between communication devices is greatly improved using the techniques described herein.

With the same antenna configuration, 2-antenna CBF (2-CBF) provides an SNR improvement of up to 10 dB over transmit/selection diversity when it is used at both ends of the link. A system design using 4 antennas at a first communication device and 2 antennas at a second communication device (hereinafter referred to as 4x2 CBF) provides nearly 14 dB of SNR improvement. In general, for a fixed number of antennas, CBF outperforms the well-known space-time block codes by up to 4 dB. Moreover, unlike space-time coding, CBF does not require a change to an existing wireless standard.

The above and other objects and advantages will become more readily apparent when reference is made to the following description taken in conjunction with the accompanying drawings.

**BRIEF DESCRIPTION OF THE DRAWINGS**

FIG. 1 is a block diagram of two communication devices performing an antenna diversity scheme using composite beamforming.

5 FIG. 2 is a block diagram of a communication device that may be used at either end of a composite beamforming communication link.

FIG. 3 is a flow chart illustrating an adaptive method to obtain antenna beamforming weights for communication between first and second communication devices.

10 FIGS. 4 and 5 are graphical diagrams illustrating convergence properties of the adaptive method shown in FIG. 3.

FIG. 6 is a diagram showing application of beamforming weights to a baseband signal for transmission in a frequency dependent communication channel.

15 FIG. 7 is a flow chart illustrating an adaptive algorithm to obtain antenna beamforming weights in a frequency dependent communication channel.

FIG. 8 is a block diagram of a composite beamforming transmission process for a multi-carrier baseband modulation scheme.

FIG. 9 is a block diagram of a composite beamforming reception process for a multi-carrier baseband modulation scheme.

20 FIG. 10 is a block diagram of a composite beamforming transmission process for a single carrier baseband modulation scheme.

FIG. 11 is a block diagram of a composite beamforming reception process for a single carrier baseband modulation scheme.

25 FIG. 12 is a flow chart of a beamforming training method where one communication device of a communication link uses antenna selection diversity.

FIG. 13 is a flow chart illustrating a collaborative method to obtain antenna processing parameters for communication between first and second communication devices.

30 **DETAILED DESCRIPTION OF THE DRAWINGS**

Referring first to FIG. 1, a system 10 is shown in which a first communication device 100 and a second communication device 200 communicate with each other using radio frequency (RF) communication techniques. The

techniques described herein are useful in any radio frequency (RF) communication application, such as short-range wireless applications. A wireless local area network (WLAN) is only an example of an application. For example, device 100 may be an access point (AP) in a WLAN, and device 200 may be a station (STA).

5 Generally, the device 100 has  $N_{ap}$  antennas 110 and the device 200 has  $N_{sta}$  antennas 210. FIG. 1 shows an example where the device 100 has three antennas 110 and the device 200 has two antennas 210. A complex transmit symbol  $s$  at device 100 is scaled (multiplied) using a set of complex transmit antenna weights  $\mathbf{w}_{tx,ap} = [w_0 \dots w_{N_{ap}-1}]^T$  before being transmitted through respective  
 10 ones of the antennas 110 ( $^T$  denotes the transpose operator). The received vector at device 200 is  $\mathbf{r}_{sta} = \mathbf{sH} \mathbf{w}_{tx,ap} + \mathbf{n}$ , where  $\mathbf{H}$  is an  $N_{sta}$  by  $N_{ap}$  channel matrix of unity variance, complex Gaussian random variables (to represent flat Rayleigh fading between each antenna), and  $\mathbf{n}$  represents noise and interference. At device  
 15 200, a combiner  $\mathbf{C} = (\mathbf{w}_{rx,sta})^H \mathbf{r}$  is applied,  $\mathbf{C}$  is passed to a detection circuit (e.g., soft-decision QAM detector, etc.). If  $\mathbf{H}$  is known at both the transmitter and the receiver,  $\mathbf{w}_{tx,ap}$  and  $\mathbf{w}_{rx,sta}$  may be selected to maximize the signal-to-noise ratio (SNR) at the output of the combiner subject to a transmit power constraint, i.e.,  
 $(\mathbf{w}_{tx,ap})^H \mathbf{w}_{tx,ap} = 1$ .

The SNR for  $\mathbf{C}$  is maximized over  $\mathbf{w}_{tx,ap}$  and  $\mathbf{w}_{rx,sta}$  when  $\mathbf{w}_{tx,ap}$  is equal to  
 20  $\mathbf{e}_{max}$ , the unit norm eigenvector for the maximum eigenvalue  $\lambda_{max}$  of the matrix  $\mathbf{H}^H \mathbf{H}$ , and  $\mathbf{w}_{rx,sta}$  is a matched filter for  $\mathbf{H} \mathbf{e}_{max}$ , i.e.,  $\mathbf{w}_{rx,sta} = k \mathbf{H} \mathbf{e}_{max}$  for some nonzero constant  $k$ . Under these conditions, the SNR for  $\mathbf{C}$  is equal to  $\lambda_{max}$ . Since  $\mathbf{H}$  is a random matrix,  $\lambda_{max}$  is a random variable. The distribution on  $\lambda_{max}$  is well known, and can be found in M. Wennstrom, M. Helin, A. Rydberg, T. Oberg, "On  
 25 the Optimality and Performance of Transmit and Receive Space Diversity in MIMO Channels", IEEE Technical Seminar on MIMO Systems, London, December, 2001, which is incorporated herein by reference.

The transmit device and the receive device communicate using time-division-duplexing at the same frequency. The channel matrix for the reverse link  
 30 is  $\mathbf{H}_r = \mathbf{H}^T$ , and the optimum transmit weight vector  $\mathbf{w}_{tx,ap}$  is equal to the eigenvector for the maximum eigenvalue of  $\mathbf{H}_r^H \mathbf{H}_r = \mathbf{H}^* \mathbf{H}^T$  ( $*$  denotes the conjugate operator). The maximum SNR at either end of the link is the same (since it is a well

known result that the nonzero eigenvalues for both  $H^*H^T$  and  $H^H H$  are the same).

The beamforming technique that results from this analysis is hereinafter referred to as composite beamforming (CBF).

The communication devices at both ends of the link, i.e., devices 100 and 200 may have any known suitable architecture to transmit, receive and process signals. An example of a communication device block diagram is shown in FIG. 2. The communication device 300 comprises an RF section 310, a baseband section 420 and optionally a host 330. There are a plurality of antennas, e.g., four antennas 302, 304, 306, 308 coupled to the RF section 310 that are used for transmission and reception. The RF section 310 has a transmitter (Tx) 312 that upconverts baseband signals for transmission, and a receiver (Rx) 314 that downconverts received RF signals for baseband processing. In the context of the composite beamforming techniques described herein, the Tx 312 upconverts and supplies separately weighted signals to corresponding ones of each of the plurality of antennas via separate power amplifiers. Similarly, the Rx 314 downconverts and supplies received signals from each of the plurality of antennas to the baseband section 320. The baseband section 320 performs processing of baseband signals to recover the information from a received signal, and to convert information in preparation for transmission. The baseband section 320 may implement any of a variety of communication formats or standards, such as WLAN standards IEEE 802.11x, Bluetooth™, as well as other protocol standards, not necessarily used in a WLAN.

The intelligence to execute the computations for the composite beamforming techniques described herein may be implemented in a variety of ways. For example, a processor 322 in the baseband section 320 may execute instructions encoded on a processor readable memory 324 (RAM, ROM, EEPROM, etc.) that cause the processor 322 to perform the composite beamforming steps described herein. Alternatively, an application specific integrated circuit (ASIC) configured with the appropriate firmware to perform the composite beamforming steps. For example, the instructions may be encoded on a medium by programming a field programmable gate array, or by defining digital logic gates in silicon in an integrated circuit. The ASIC may be part of, or the entirety of, the baseband section 320. Still another alternative is for the

beamforming computations to be performed by a host processor 332 (in the host 330) by executing instructions stored in (or encoded on) a processor readable memory 334. The RF section 310 may be embodied by one integrated circuit, and the baseband section 320 may be embodied by another integrated circuit. The communication device on each end of the communication link need not have the same device architecture or implementation.

Regardless of the specific implementation chosen, the composite beamforming process is generally performed as follows. A transmit weight vector (comprising a plurality of complex transmit antenna weights corresponding to the number of transmit antennas) is applied to, i.e., multiplied by, a baseband signal to be transmitted, and each resulting weighted signal is coupled to a transmitter where it is upconverted, amplified and coupled to a corresponding one of the transmit antennas for simultaneous transmission. At the communication device on the other end of the link, the transmit signals are detected at each of the plurality of antennas and downconverted to a baseband signal. Each baseband signal is multiplied by a corresponding one of the complex receive antenna weights and combined to form a resulting receive signal. The architecture of the RF section necessary to accommodate the beamforming techniques described herein may vary with a particular RF design, and many are known in the art and thus is not described herein.

Turning to FIG. 3, a process 400 is shown for achieving optimum CBF between two communication devices. To restate the results from the previous discussion, the optimum receive and transmit weights at the AP are given by  $\mathbf{w}_{\text{rx,ap}} = \mathbf{e}_{\text{max}}(\text{of } \mathbf{H}^H \mathbf{H})$ ,  $\mathbf{w}_{\text{tx,ap}} = \mathbf{w}_{\text{rx,ap}}^*$ . The optimum receive and transmit weights at the STA are given by  $\mathbf{w}_{\text{rx,sta}} = \mathbf{e}_{\text{max}}(\text{of } \mathbf{H}^* \mathbf{H}^T)$ ,  $\mathbf{w}_{\text{tx,sta}} = \mathbf{w}_{\text{rx,sta}}^*$ . Additionally,  $\mathbf{w}_{\text{rx,sta}} = \mathbf{H} \mathbf{w}_{\text{tx,ap}}$ ,  $\mathbf{w}_{\text{rx,ap}} = \mathbf{H}^T \mathbf{w}_{\text{tx,sta}}$ . These properties can be utilized to design an adaptive/iterative algorithm that converges to the optimum eigenvector as follows.

Initially, in step 410, the AP uses an arbitrary set of transmit antenna weights to transmit a signal to the STA. When the STA receives the signal, the receive antenna weights at the STA are matched to the receive signal such that  $\mathbf{w}_{\text{rx,sta}}(0) = \mathbf{H} \mathbf{w}_{\text{tx,ap}}(0)$ . That is, the STA receive antenna weights are computed from the received signals at each of the antennas by matching to the received

signals. In step 420, the STA computes the conjugate of the receive weight vector made up of the receive antenna weights for use as the transmit antenna weight vector for transmitting on the STA's antennas back to the AP. The AP receives the signal transmitted by the plurality of antennas of the STA and matches the receive antenna weights to the received signal.

In step 430, the AP updates the new transmit antenna weights by computing the conjugate of the receive weight vector (comprised of the AP receive antenna weights) divided by the norm of the AP receive weight vector. This process repeats in steps 440 through 460, ad infinitum. It can be shown that the weights converge to the eigenvector corresponding to the maximum eigenvalue. See G. Golub, C. V. Loan, "Matrix Computations", 2nd edition, pp. 351.

Within a few iterations, the transmit weight vector and receive antenna weight vector of both devices will converge to values that optimize the SNR at each of the devices. At such point, the first communication device may store in a memory (in the baseband section or host processor section) the current optimum transmit antenna weights for a particular destination communication device indexed against an identifier for that communication device. The first communication device, such as an AP, may store in a look-up-table optimum transmit antenna weights indexed against corresponding identifiers (such as MAC addresses) for a plurality of other communication devices it communicates with.

The adaptive process of FIG. 3 will converge to optimum antenna weights even if one device has multiple antennas and can weight signals supplied thereto, and the other device is a merely a single antenna device. The device on the link with the multiple antennas and combining capability can still converge to its optimum transmit and receive weights for a single antenna device it communicates with.

With reference to FIGs. 4 and 5, the convergence properties of the adaptive algorithm were studied over 1000 randomly generated channels. The average SNR at each receive antenna was set to 10 dB. The normalized antenna array gain at the output of the receive antenna array,  $|\mathbf{H}\mathbf{w}_{\text{tx}}|^2/\lambda_{\text{max}}(\mathbf{H}^H\mathbf{H})$  is used to study the performance. In FIG. 4, ( $N_{\text{ap}} = 2, N_{\text{sta}} = 2$ ), it is shown that the adaptive algorithm loss is less than a 1 dB at the 3rd iteration with 95% probability. When



the number of antenna elements is increased to four, only one additional iteration was required for the algorithm converge to less than 1 dB loss with 95% probability.

An advantage of adaptive composite beamforming is that no special training sequence is required for adaptation. In addition, no changes to existing protocols are necessary, and there is no impact on throughput. The antenna weights are updated when real information or data is transmitted between devices. Transmit and receive weight adaptation is the same regardless of whether CBF is implemented at both ends of the link

However, if the destination device uses selection diversity the performance can be improved by estimating the channel response.

The indoor wireless channel is a frequency dependent channel. Due to multi-path propagation the signal arrives at the receiver with different delays. The different delays cause the channel transfer function to be frequency selective. Therefore, to account for these delays, the antenna weights need to be adjusted according to the frequency dependent characteristics of the channel transfer function between the transmitting device and the receiving device.

Solutions for optimum antenna processing in a frequency selective channel are described hereinafter. Between any two communication devices, the communication channel will have a frequency response depending on frequency selective fading conditions, etc. The channel transfer function  $\mathbf{H}(f)$  describes the frequency response and is used to select the optimum antenna transmit and receive weights for communication between those terminals.

To understand the frequency selective situation, reference is again made to FIG. 1, where the frequency dependent Nsta by Nap transfer function between the first and communication device and the second communication devices is denoted by the  $\mathbf{H}(f)$ . The Nap by Nsta transfer function between the second communication device and the first communication device is  $\mathbf{H}^T(f)$ . The transmit weights at the first and second communication devices are denoted by the Nap x 1 vector  $\mathbf{w}_{\text{tx,ap}}(f)$  and the Nsta x 1 vector  $\mathbf{w}_{\text{tx,sta}}(f)$ , respectively.

$$\mathbf{w}_{\text{tx,ap}}(f) = [\mathbf{w}_{\text{tx,ap},1}(f), \mathbf{w}_{\text{tx,ap},2}(f), \dots, \mathbf{w}_{\text{tx,ap},\text{Nap}}(f)]^T$$

$$\mathbf{w}_{\text{tx,sta}}(f) = [\mathbf{w}_{\text{tx,sta},1}(f), \mathbf{w}_{\text{tx,sta},2}(f), \dots, \mathbf{w}_{\text{tx,sta},\text{Nsta}}(f)]^T$$

The receive weights at the first and second communication devices are denoted by the  $N_{ap} \times 1$  vector  $\mathbf{w}_{rx,ap}(f)$  and the  $N_{sta} \times 1$  vector  $\mathbf{w}_{rx,sta}(f)$ , respectively

$$\begin{aligned} \mathbf{w}_{rx,ap}(f) &= [w_{rx,ap,1}(f), w_{rx,ap,2}(f), \dots, w_{rx,ap,N_{ap}}(f)]^T \\ \mathbf{w}_{rx,sta}(f) &= [w_{rx,sta,1}(f), w_{rx,sta,2}(f), \dots, w_{rx,sta,N_{sta}}(f)]^T \end{aligned}$$

The transmit and receive weights (only the first communication device-second communication device link is described below but the results apply in the reverse direction with appropriate change in notation) are computed by optimizing a cost function,  $C$ , with a constraint on the maximum transmit power. In a communication system, the ultimate goal is to reduce bit-error rate (BER).

However, optimization using the BER as a cost function is not always analytically feasible. Therefore, cost functions that implicitly reduce the BER are usually selected. The cost function also depends on the receiver structure. Selection of the cost function for different modulation schemes and receiver structures is discussed.

$$\min_{\mathbf{w}_{tx,ap}, \mathbf{w}_{rx,sta}} \int_{-1/2T}^{1/2T} C(\mathbf{H}(f), \mathbf{w}_{tx,ap}(f), \mathbf{w}_{rx,sta}(f)) df, \text{ subject to } \int_{-1/2T}^{1/2T} |\mathbf{w}_{tx,ap}(f)|^2 df \leq P_0$$

For a code division multiple access (CDMA) communication system, such as IEEE 802.11b, the receiver is assumed to be a RAKE receiver and the BER is a function of the SNIR (signal to noise + interference ratio) at the output of the RAKE receiver. Maximizing the SNIR at the output of the RAKE receiver minimizes the BER.

$$\max_{\mathbf{w}_{tx,ap}, \mathbf{w}_{rx,sta}} \int_{-1/2T}^{1/2T} SNIR(\mathbf{H}(f), \mathbf{w}_{tx,ap}(f), \mathbf{w}_{rx,sta}(f)) df, \text{ subject to } \int_{-1/2T}^{1/2T} |\mathbf{w}_{tx,ap}(f)|^2 df \leq P_0$$

For an orthogonal frequency division multiplex (OFDM) system, such as IEEE 802.11a, the receiver is a linear equalizer followed by a Viterbi decoder. Since the Viterbi decoder is a non-linear operator, optimizing the coded BER is very challenging. An alternative is to minimize the mean square error (MSE) at the

output of the linear equalizer (note another possible approach is to minimize the uncoded BER).

$$5 \quad \min_{\mathbf{w}_{tx,ap} \mathbf{w}_{rx,sta}} \int_{-1/2T}^{1/2T} MSE(\mathbf{H}(f), \mathbf{w}_{tx,ap}(f), \mathbf{w}_{rx,sta}(f)) df, \text{ subject to } \int_{-1/2T}^{1/2T} |\mathbf{w}_{tx,ap}(f)|^2 df \leq P_0$$

A single carrier modulation scheme, such as IEEE 802.11b, uses a decision feedback equalizer (DFE) at the receiver. The receiver is a non-linear receiver.

$$10 \quad \min_{\mathbf{w}_{tx,ap} \mathbf{w}_{rx,sta}^B} \int_{-1/2T}^{1/2T} MSE(\mathbf{H}(f), \mathbf{w}_{tx,ap}(f), \mathbf{w}_{rx,sta}(f)) df, \text{ subject to } \int_{-1/2T}^{1/2T} |\mathbf{w}_{tx,ap}(f)|^2 df \leq P_0$$

The transmit, receive and feedback weights are computed jointly. This can be achieved by minimizing the MSE at the output of the DFE.

15 For all cases considered, the optimum transmit weights are given by

$$\mathbf{w}_{tx,ap}(f) = p(f) \mathbf{e}_{\max}(\mathbf{H}^H(f) \mathbf{H}(f))$$

where  $\mathbf{e}_{\max}$  is the eigenvector corresponding to the maximum eigenvalue of the matrix  $\mathbf{H}^H(f) \mathbf{H}(f)$ , where  $p(f)$  is a weighting function that weights each individual frequency bin and is based on the cost function. Typically, the solution to  $p(f)$

20 follows a waterpouring distribution.

For the linear equalizer case, the solution is given by

$$25 \quad p^2(f) = \sqrt{\frac{1}{\mu \frac{\sigma_s^2}{\sigma_n^2} \lambda_{\max}(f)} - \frac{1}{\frac{\sigma_s^2}{\sigma_n^2} \lambda_{\max}(f)}} \quad SNR = \frac{\sigma_s^2}{\sigma_n^2}$$

For the DFE case, the solution is

$$p^2(f) = \frac{1}{\mu} - \frac{1}{\frac{\sigma_s^2}{\sigma_n^2} \lambda_{\max}(f)}$$

30 where  $\mu$  is selected to satisfy the power constraint

$$\int_{-1/2T}^{1/2T} p^2(f) df = P_0$$

An optimal solution for  $p(f)$  requires knowledge of the channel and SNR at the receiver. A suboptimal solution is obtained by setting  $p(f)$  to a constant,  $p$ , across frequency.

$$5 \quad \mathbf{w}_{tx,ap}(f) = p \mathbf{e}_{\max}(\mathbf{H}^H(f) \mathbf{H}(f))$$

This is referred to herein as a frequency shaping constraint. To explain further, the frequency shaping constraint requires that at each frequency of the baseband signal to be transmitted (e.g., frequency sub-band or frequency sub-carrier  $k$ ), the sum of the power of signals across all of the transmit antennas is equal to a constant value,  $P_{tx}/K$ . This constraint is useful to ensure that, in an iterative process between two communication devices, the transmit weights of the two devices will converge to optimal values. An additional benefit of this constraint is that the transmitting device can easily satisfy spectral mask requirements of a communication standard, such as IEEE 802.11x.

15 This solution does not require knowledge of the receiver SNR and simulations have shown that the loss in performance over the optimal solution is negligible. However, this solution requires knowledge of the channel response at the transmitter.

For the cost functions maximizing the SNIR or minimizing the MSE for a linear equalizer, the optimum receive weights are given by

$$20 \quad \mathbf{w}_{rx,sta}(f) = \mathbf{R}_{ss}^{-1}(f) \mathbf{v}_{mf,sta}(f)$$

where  $\mathbf{v}_{mf,sta}(f)$  is matched to the received signal

$$25 \quad \mathbf{v}_{mf,sta}(f) = \mathbf{H}(f) \mathbf{w}_{tx,ap}(f)$$

and  $\mathbf{R}_{ss}(f)$  is the correlation matrix defined as

$$30 \quad \begin{aligned} \mathbf{R}_{ss}(f) &= \sigma_s^2 \mathbf{H}(f) \mathbf{w}_{tx,ap}(f) \mathbf{w}_{tx,ap}^H(f) \mathbf{H}^H(f) + \sigma_n^2 \mathbf{I} \\ &= \sigma_s^2 \mathbf{v}_{mf,sta}(f) \mathbf{v}_{mf,sta}^H(f) + \sigma_n^2 \mathbf{I} \end{aligned}$$

When the MSE of the DFE is the minimized, the optimum receive weights are given by

$$\mathbf{w}_{rx,sta}(f) = \mathbf{R}_{ss}^{-1}(f)\mathbf{v}_{mf,sta}(f)(1+B(f))$$

where B(f) is the feedback filter.

5 The weights for the reverse link are similar to the forward link and is summarized below. The optimum transmit weights at the second communication are given by

$$\mathbf{w}_{tx,sta}(f) = p(f) \mathbf{e}_{\max}(\mathbf{H}^*(f) \mathbf{H}^T(f))$$

and the suboptimal transmit weights are

10 
$$\mathbf{w}_{tx,sta}(f) = p \mathbf{e}_{\max}(\mathbf{H}^*(f) \mathbf{H}^T(f))$$

Similarly, the receive weights at the first communication device are given by

$$\mathbf{w}_{rx,ap}(f) = \mathbf{R}_{aa}^{-1}(f)\mathbf{v}_{mf,ap}(f)$$

15 where 
$$\mathbf{v}_{mf,ap}(f) = \mathbf{H}^T(f)\mathbf{w}_{tx,sta}(f)$$

and for DFE case

$$\mathbf{R}_{aa}(f) = \sigma_s^2 \mathbf{v}_{mf,ap}(f)\mathbf{v}_{mf,ap}^H(f) + \sigma_n^2 \mathbf{I}$$

$$\mathbf{w}_{rx,ap}(f) = \mathbf{R}_{aa}^{-1}(f)\mathbf{v}_{mf,ap}(f)(1+B(f))$$

20 In the presence of co-channel interference  $\mathbf{R}_{ss}(f)$  is given by

$$\mathbf{R}_{ss}(f) = \sigma_s^2 \mathbf{H}(f)\mathbf{w}_{tx,ap}(f)\mathbf{w}_{tx,ap}^H(f)\mathbf{H}^H(f) + \sum_{k \neq 0} \sigma_k^2 \mathbf{H}_k(f)\mathbf{w}_k(f)\mathbf{w}_k^H(f)\mathbf{H}_k^H(f) + \sigma_n^2 \mathbf{I}$$

25 where the terms in the summation are the contribution due to the interferers. In this case, the optimum receive antenna weights minimize the contribution of the interferers and the noise. Therefore, in addition to diversity gain, optimum antenna combining at the receiver also provides interference suppression capability.

FIG. 6 illustrates how frequency selective beamforming weights are applied to a baseband signal. The baseband signal may be a single carrier signal or a multi-carrier signal. In either case, the baseband signal will have a bandwidth or  
 30 spectrum. According to the composite beamforming (CBF) technique described herein, when communication device 100 transmits a signal to communication device 200, it applies (i.e., multiplies or scales) a baseband signal *s* to be

transmitted by a transmit weight vector associated with a particular destination device, e.g., communication device 200, denoted  $\mathbf{w}_{\text{tx},1}$ . Similarly, when communication device 200 transmits a baseband signal  $s$  to communication device 100, it multiplies the baseband signal  $s$  by a transmit weight vector  $\mathbf{w}_{\text{tx},2}$ , associated with destination communication device 100. The  $(M \times N)$  frequency dependent channel matrix from the  $N$  plurality of antennas of the first communication device 100 to  $M$  plurality of antennas of the second communication device 200 is  $\mathbf{H}(k)$ , and the frequency dependent communication channel  $(N \times M)$  matrix between the  $M$  plurality of antennas of the second communication device and the  $N$  plurality of antennas of the first communication device is  $\mathbf{H}^T(k)$ . The variable  $k$  denotes the frequency dependent characteristic as explained further hereinafter.

The transmit weight vectors  $\mathbf{w}_{\text{tx},1}$  and  $\mathbf{w}_{\text{tx},2}$  each comprises a plurality of transmit weights corresponding to each of the  $N$  and  $M$  antennas, respectively. Each transmit weight is a complex quantity. Moreover, each transmit weight vector is frequency dependent; it varies across the bandwidth of the baseband signal  $s$  to be transmitted. For example, if the baseband signal  $s$  is a multi-carrier signal of  $K$  sub-carriers, each transmit weight for a corresponding antenna varies across the  $K$  sub-carriers. Similarly, if the baseband signal  $s$  is a single-carrier signal (that can be divided into  $K$  frequency sub-bands), each transmit weight for a corresponding antenna varies across the bandwidth of the baseband signal. Therefore, the transmit weight vector is dependent on frequency, or frequency sub-band/sub-carrier  $k$ , such that  $\mathbf{w}_{\text{tx}}$  becomes  $\mathbf{w}_{\text{tx}}(f)$ , or more commonly referred to as  $\mathbf{w}_{\text{tx}}(k)$ , where  $k$  is the frequency sub-band/sub-carrier index.

While the terms frequency sub-band/sub-carrier are used herein in connection with beamforming in a frequency dependent channel, it should be understood that the term "sub-band" is meant to include a narrow bandwidth of spectrum forming a part of a baseband signal. The sub-band may be a single discrete frequency (within a suitable frequency resolution that a device can process) or a narrow bandwidth of several frequencies.

The receiving communication device also weights the signals received at its antennas with a frequency dependent receive antenna weight vector  $\mathbf{w}_{\text{rx}}(k)$ . Communication device 100 uses a receive antenna weight vector  $\mathbf{w}_{\text{rx},1}(k)$  when

receiving a transmission from communication device 200, and communication device 200 uses a receive antenna weight vector  $\mathbf{w}_{\text{rx},2}(\mathbf{k})$  when receiving a transmission from communication device 100. The receive antenna weights of each vector are matched to the received signals by the receiving communication device.

Generally, transmit weight vector  $\mathbf{w}_{\text{tx},1}$  comprises a plurality of transmit antenna weights  $w_{\text{tx},1,i} = \beta_{1,i}(\mathbf{k})e^{j\phi_{1,i}(\mathbf{k})}$ , where  $\beta_{1,i}(\mathbf{k})$  is the magnitude of the antenna weight,  $\phi_{1,i}(\mathbf{k})$  is the phase of the antenna weight,  $i$  is the antenna index (up to  $N$ ), and  $\mathbf{k}$  is the frequency sub-band or sub-carrier index (up to  $K$  frequency sub-bands/sub-carriers). The subscripts  $\text{tx},1$  denote that it is a vector that communication device 100 uses to transmit to communication device 2. Similarly, the subscripts  $\text{tx},2$  denote that it is a vector that communication device 200 uses to transmit to communication device 100.

The frequency shaping constraint described above may be imposed on the transmit weights for each antenna. As mentioned above, the constraint requires that at each frequency of the baseband signal to be transmitted (e.g., frequency sub-band or frequency sub-carrier  $\mathbf{k}$ ), the sum of the power of signals across all of the transmit antennas ( $|w_{\text{tx},i}(\mathbf{k})|^2$  for  $i = 1$  to  $N$ ) is equal to a constant value,  $P_{\text{tx}}/K$ .

The relationship between transmit and receive weights are summarized below:

The optimum receive and transmit weights at the first communication device are related as follows.

$$\mathbf{w}_{\text{tx},\text{ap}}(\mathbf{f}) = \mathbf{e}\text{max}(\mathbf{H}^H(\mathbf{f}) \mathbf{H}(\mathbf{f})), \mathbf{v}_{\text{mf},\text{sta}}(\mathbf{f}) = \mathbf{H}(\mathbf{f}) \mathbf{w}_{\text{tx},\text{ap}}(\mathbf{f})$$

Similarly at the second communication device, the optimum receive and transmit weights are related as follows.

$$\mathbf{w}_{\text{tx},\text{sta}}(\mathbf{f}) = \mathbf{e}\text{max}(\mathbf{H}^*(\mathbf{f}) \mathbf{H}^T(\mathbf{f})), \mathbf{v}_{\text{mf},\text{ap}}(\mathbf{f}) = \mathbf{H}^T(\mathbf{f}) \mathbf{w}_{\text{tx},\text{sta}}(\mathbf{f})$$

Additionally,

$$\mathbf{v}_{\text{mf},\text{ap}}(\mathbf{f}) = \mathbf{w}_{\text{tx},\text{ap}}^*(\mathbf{f}), \mathbf{v}_{\text{mf},\text{sta}}(\mathbf{f}) = \mathbf{w}_{\text{tx},\text{sta}}^*(\mathbf{f})$$

The properties outlined above can be utilized in an adaptive/iterative process 480 shown in FIG. 7 that is similar to the process shown in FIG. 3. The antenna weight parameters in FIG. 4 are written with indexes to reflect communication between an AP and a STA, but without loss of generality, it should

be understood that this process is not limited to a WLAN application, and is useful in any wireless application, such as a short-range application. The AP has  $N_{ap}$  antennas and the STA has  $N_{sta}$  antennas. Assuming the AP begins with the first transmission to the STA, the initial AP transmit weight vector  $\mathbf{w}_{T,AP,0}(k)$  is

5  $[1, 1, \dots, 1]$ , normalized by  $1/(N_{ap})^{1/2}$  for all antennas and all frequency sub-bands/sub-carriers  $k$ . Phase for the transmit antenna weights are also initially set to zero. The index T indicates it is a transmit weight vector, index AP indicates it is an AP vector, index 0 is the iteration of the vector, and  $(k)$  indicates that it is frequency sub-band/sub-carrier dependent. In step 482, a baseband signal is

10 scaled by the initial AP transmit weight vector  $\mathbf{w}_{T,AP,0}(k)$ , upconverted and transmitted to the STA by the  $N_{ap}$  antennas. The transmitted signal is effectively altered by the frequency selective channel matrix  $\mathbf{H}(k)$  from AP-STA. The STA receives the signal and matches its initial receive weight vector  $\mathbf{w}_{R,STA,0}(k)$  to the signals received at its antennas. In step 484, the STA normalizes the receive

15 weight vector  $\mathbf{w}_{R,STA,0}(k)$  and computes the conjugate of normalized receive weight vector to generate the STA's initial transmit weights for transmitting a signal back to the AP. In step 486, the STA processes the signal to be transmitted to the AP by the initial transmit weight vector, upconverts that signal and transmits it to the AP. The transmitted signal is effectively altered by the frequency selective channel

20 matrix  $\mathbf{H}^T(k)$ . At the AP, the receive weight vector is matched to the signals received at its antennas. The AP then computes the conjugate of the gain-normalized receive weight vector as the next transmit weight vector  $\mathbf{w}_{T,AP,1}(k)$  and transmits a signal to the STA with that transmit weight vector. The STA receives the signal transmitted from the AP with this next transmit weight vector and

25 matches to the received signals to compute a next receive weight vector  $\mathbf{w}_{R,STA,1}(k)$ . Again, the STA computes the conjugate of the gain-normalized receive weight vector  $\mathbf{w}_{R,STA,1}(k)$  as its next transmit weight vector  $\mathbf{w}_{T,STA,1}(k)$  for transmitting a signal back to the AP. This process repeats for several iterations as shown by steps 488 and 490, ultimately converging to transmit weight vectors that achieve nearly

30 the same performance as non-equal gain composite beamforming. This adaptive process works even if one of the devices, such as a STA, has a single antenna for transmission and reception.



When storing the transmit weights of a frequency transmit weight vector, in order to conserve memory space in the communication device, the device may store, for each antenna, weights for a subset or a portion of the total number of weights that span the bandwidth of the baseband signal. For example, if there are 5 K weights for K frequency sub-bands or sub-carrier frequencies, only a sampling of those weights are actually stored, such as weights for every other, every third, every fourth, etc., k sub-band or sub-carrier. Then, the stored subset of transmit weights are retrieved from storage when a device is to commence transmission of a signal, and the remaining weights are generated by interpolation from the stored 10 subset of weights. Any suitable interpolation can be used, such as linear interpolation, to obtain the complete set of weights across the K sub-bands or sub-carriers for each antenna.

It may be desirable for a first device initiating communication with a second device to transmit an initial packet to the second device using transmit delay 15 diversity (TDD) techniques to increase the likelihood that the second device will receive the initial packet, and therefore be able to beamform back a packet to the first device. TDD techniques essentially increase the range of the initial packet and are particularly useful when the channel with the other device is not known, hence transmit beamforming a signal to that device would not ensure reception by the 20 other device. This is the case when transmitting a packet for the first time. This may be useful when one communication device has not been in communication with another particular communication device for a significant period of time. The channel may be different due to a new location of one or both of the devices and when new objects or obstructions have been placed in the channel between the 25 devices. Also, an existing communication link may be lost, and efforts to re-establish it with composite beamforming may not work.

In any event, the initial packet is transmitted, in step 482 of FIG. 7, using TDD techniques rather than with an arbitrary transmit weight vector, e.g.,  $[1, 1, 1, \dots, 1]^T$ . For example, the AP may transmit the initial packet to a STA using TDD. 30 The initial packet may be a broadcast packet, such as a beacon in IEEE 802.11 parlance, or a directed packet. When transmitting an initial packet using TDD, the signal to be transmitted is multiplied by a transmit weight vector that performs the

TDD function, i.e.,  $x(t + \tau)$  in the time domain, which is analogous to  $X(f)e^{j2\pi f\tau}$  in the frequency domain, where the transmit weight at frequency  $f$  is  $e^{-j2\pi f\tau}$ . The TDD transmit weight vector has unit normalized gain, and for  $N$  antennas can be expressed as a transmit weight vector  $[e^{-j2\pi f\tau_1}, e^{-j2\pi f\tau_2}, e^{-j2\pi f\tau_i}, \dots, e^{-j2\pi f\tau_N}]^T$  for  $i = 1$  to  $N$ , where  $\tau_1$  is a time delay for antenna 1,  $\tau_2$  is a time delay for antenna 2, and in general  $\tau_i$  is a time delay for antenna  $i$ . As an example, the time delay  $\tau_1$  is 0, the time delay  $\tau_2$  is  $s$  (where  $s$  is a sample time), the time delay  $\tau_3$  is  $2s$ , and in general the time delay for antenna  $i$  would be  $(i-1)s$ . The STA would receive the initial packet sent using TDD, receive match to the received initial packet and then generate transmit weights (as described above in conjunction with FIG. 7) from the receive weights used to combine the received signals, for transmitting a packet to the AP as shown in step 484. From then on, the process continues as shown in FIG. 7. That is, the AP receives the packet from the STA, and will receive match to it (gaining knowledge about the channel) to compute transmit weights for transmitting to that STA.

The same technique may be used in the reverse direction, whereby the STA transmits an initial packet to the AP using TDD. For example, in the IEEE 802.11 WLAN example, a STA may turn on and either listen for a beacon from an AP or transmit a probe request to the AP. If the STA receives a beacon signal, it can receive match to it, generate a transmit weight vector, and transmit a packet back to the AP using transmit beamforming, and the process of FIG. 7 will proceed as described above. On the other hand, if the STA does not wait for a beacon, and instead transmits a probe request signal to the AP, it will transmit the probe request signal using TDD to increase the range of the probe request to increase the chance that the AP will receive it. Then, the AP can receive match, and beamform back to the STA, and the process of FIG. 7 will proceed as described above.

With reference to FIG. 8, a beamforming transmission process 500 is shown for a multi-carrier baseband modulation scheme. For an orthogonal frequency division multiplexed (OFDM) system used, for example, by the IEEE 802.11a standard, the data symbols are in the frequency domain.  $K$  symbols are assigned to  $K$  sub-carriers ( $K = 52$  for 802.11a). For convenience, each of the transmit antenna weights are described as a function of  $(k)$ , the sub-carrier frequency. Each of the  $N$

antennas has a transmit antenna weight  $w_{tx}$  that is a function of  $k$ , i.e.,  $w_{tx}(k)$  over  $k = 1$  to  $K$ . The transmit antenna weights are computed by any of the processes described above at each of the sub-carrier frequencies. There is a signal processing path for each of the  $N$  antennas. In each signal processing path, a multiplier 510 multiplies the frequency domain symbol  $s(k)$  by the corresponding transmit antenna weight  $w_{tx}(k)$  and because  $w_{tx}(k)$  has  $K$  values, there are  $K$  results from the multiplication process. The results are stored in a buffer 520 for  $k = 1$  to  $K$ . An inverse Fast Fourier Transform (IFFT) 530 is coupled to the buffer to convert the frequency domain results stored in buffer 520 to a digital time domain signal for each of the  $K$  sub-carriers. There is some adjustment made for cyclic prefixes caused by the OFDM process. A filter 540 provides lowpass filtering of the result of the IFFT process. The digital results of the filtering process are converted to analog signals by a D/A 550. The outputs of the D/A 550 are coupled to RF circuitry 560 that upconverts the analog signals to the appropriate RF signal which is coupled via a power amplifier (PA) 570 to one of the  $N$  antennas 580. In this manner, for each antenna 580, the signal  $s(k)$  is multiplied by respective transmit antenna weights whose values may vary as a function of the sub-carrier frequency  $k$ . The frequency shaping constraint described above can also be applied to the antenna weights.

FIG. 9 shows a beamforming reception process 600 that is essentially the inverse of the transmission process shown in FIG. 8. There is a signal processing channel for each of the antennas 580. RF circuitry 610 downconverts the RF signals detected at each antenna 580 for each of the sub-carriers. An A/D 620 converts the analog signal to a digital signal. A lowpass filter 630 filters the digital signal. There is some adjustment made for cyclic prefixes caused by the OFDM process. A buffer 640 stores the time domain digital signal in slots associated with each sub-carrier frequency  $k$ . An FFT 650 converts the time domain digital signal in buffer 640 to a frequency domain signal corresponding to each sub-carrier frequency  $k$ . The output of the FFT 650 is coupled to a multiplier 660 that multiplies the digital signal for each sub-carrier  $k$  by a corresponding receive antenna weight  $w_{rx}(k)$  for the corresponding one of the  $N$  antennas. The outputs of each of the multipliers 660 are combined by an adder 670 to recover the digital

frequency domain symbol  $s(k)$ . The signal  $s(k)$  is then mapped back to symbol  $b(k)$ .

FIGs. 10 and 11 show transmission and reception processes, respectively, for frequency dependent beamforming applied to a single carrier baseband modulation scheme, such as that used by the IEEE 802.11b standard. The data symbols in such a system are in the time domain. FIG. 10 shows a beamforming transmission process 700 suitable for a single carrier modulation scheme. Since in a frequency dependent channel, the transmit antenna weights are frequency dependent, the passband of the baseband signal is synthesized into frequency bins (K bins) and transmit beamforming weights are computed for each frequency bin using any of the processes described above. There are processing channels for each antenna. In each processing channel, transmit filters 710 are synthesized with the frequency response specified by the beamforming weights. Thus, each transmit filter 710 has a frequency response defined by the transmit antenna weight  $w_{tx}(f)$  associated with that antenna. The data symbol  $s(n)$  is passed through the transmit filter 710 which in effect applies the frequency selective antenna weight to the data symbol  $s(n)$ . The D/A 720 converts the digital output of the transmit filter 710 to an analog signal. The RF circuitry 730 upconverts the analog signal and couples the upconverted analog signal to an antenna 750 via a power amplifier 740. The frequency shaping constraint described above can also be applied to the antenna weights.

FIG. 11 shows a reception process 800 suitable for a single carrier modulation scheme. There is a processing channel for each antenna 750. In each processing channel, RF circuitry 810 downconverts the received RF signal. An A/D 820 converts the downconverted analog signal to a digital signal. Like the frequency dependent transmit antenna weights, the receive antenna weights are computed for several frequency sub-bands. Receive filters 830 are synthesized with the frequency response specified by the receive beamforming weights  $w_{rx}(f)$  and the received digital signal is passed through filters 830 for each antenna, effectively applying a frequency dependent antenna weight to the received signal for each antenna. The results of the filters 830 are combined in an adder 850, and then passed to a demodulator 860 for demodulation.

Referring next to FIG. 12, a procedure is shown for use when only one of the two devices supports beamforming. For example, N-CBF is supported at a first communication device (an AP) but not at a second communication device (a STA). In this case, the STA is likely to support 2-antenna Tx/Rx selection  
5 diversity as discussed previously. If this is the case, it is possible for the AP to achieve 3 dB better performance than Nth order maximal ratio combining (MRC) at both ends of the link.

When the STA associates or whenever a significant change in channel response is detected, the AP sends a special training sequence to help the STA  
10 select the best of its two antennas. The training sequence uses messages entirely supported by the applicable media access control protocol, which in the following example is IEEE 802.11x.

The sequence consists of 2 data units (such as an IEEE 802.11 MSDU ideally containing data that is actually meant for the STA so as not to incur a loss in  
15 throughput). In step 900, the first communication device sends the first data unit using the Tx weight vector  $[1 \ 0 \ \dots \ 0]^T$ . That is, the first communication device sends the first data unit exclusively by one of its N antennas. In step 910, the second communication device responds by transmitting a message using one of its two antennas. The first device decodes the message from the second device, and  
20 obtains one row of the H matrix (such as the first row  $h_{r1}$ ). In step 920, the first device sends the second MSDU using a weight vector which is orthogonal to the first row of H (determined in step 910). When the second device receives the second MSDU, in step 930, standard selection diversity logic forces it to transmit a response message in step 930 using the other antenna, allowing the first device to  
25 see the second row of the H matrix,  $h_{r2}$ . Now the first device knows the entire H matrix. The first device then decides which row of the H matrix will provide "better" MRC at the second device by computing a norm of each row,  $h_{r1}$  and  $h_{r2}$ , of the H matrix and, and selecting the row that has the greater norm as the transmit weight vector for further transmissions to that device until another change is  
30 detected in the channel.

For the frequency sensitive case, the process shown in FIG. 11 is repeated at each of a plurality of frequency sub-bands that span the bandwidth of a single

carrier baseband signal to be communicated between the devices, or at each of the sub-carrier frequencies of a multi-carrier baseband signal to be communication between the devices.

Turning to FIG. 13 with continued reference to FIG. 1, a method is described for a collaborative approach for maintaining channel response information at one communication device for transmission with another communication device. Initially, in step 1000, one communication device determines which other communication devices are CBF-capable using a special CBF-capability request message. For example, this message is sent by an AP whenever a new STA associates with the AP. Non-CBF-capable devices will not respond to the message since they will not recognize it without CBF capability. Once it has confirmed CBF capability, whenever a CBF-capable device (AP or STA) sends information to the other device, in step 1010, a CBF training sequence is generated and appended to a data unit. For example, in the context of IEEE 802.11x, when a directed media access control (MAC) Protocol Data Unit (MPDU) to another CBF-capable terminal, it appends a small ( $2*N$  orthogonal frequency division multiplexed (OFDM) symbols,  $N$  = the number of antennas of the transmitting device) CBF training sequence containing channel response information at the end of the MPDU data segment. For example, the CBF training sequence may comprise  $N$  consecutive 2-symbol long preamble sequences as defined in 802.11a. These  $N$  sequences are multiplied by respective ones of  $N$  linearly independent vectors that span the column matrix of the channel response matrix. Such  $N$  linearly independent vectors may be, for example, the transmitted using the transmit weight vectors  $[1\ 0\ \dots\ 0]^T$ ,  $[0\ 1\ 0\ \dots\ 0]^T$ , ...,  $[0\ 0\ \dots\ 1]^T$ . These vectors essentially cause individual sequences to be transmitted exclusively on separate ones of the antennas, and nevertheless produce a column vector of the channel response matrix  $H$  at the receiving terminal. The CBF training sequence is appended to the MPDU and transmitted to the destination communication device in step 1020. The transmitting terminal uses the optimum transmit weight vector when transmitting all other portions of the MPDU.

In step 1030, the destination device receives and decodes the normal portion of the incoming MPDU using a matched filter derived using the long preamble at

the beginning of the incoming burst to determine the optimum phase and gain relationships on each receive antenna. Also, in step 1040, the destination device updates the transmit weight vector to use when transmitting to the source device (including the ACK to the incoming MPDU, for example) using the channel response matrix H derived from the CBF training sequence.

For example, suppose there are three antennas at the AP and two antennas at the STA. The CBF training sequence that the AP sends to the STA is transmitted using the transmit weight vectors  $[1\ 0\ 0]^T$ ,  $[0\ 1\ 0]^T$  and  $[0\ 0\ 1]^T$ . The channel response H vector between these two devices is a 2 x 3 matrix defined as  $[h_{11}\ h_{12}]^T$ ,  $[h_{21}\ h_{22}]^T$  and  $[h_{31}\ h_{32}]^T$ . When these transmit weight vectors are applied to the symbol s and transmitted, the result is  $s[h_{11}\ h_{12}]^T$ ,  $s[h_{21}\ h_{22}]^T$  and  $s[h_{31}\ h_{32}]^T$ . Therefore, the column vectors  $[h_{11}\ h_{12}]^T$ ,  $[h_{21}\ h_{22}]^T$  and  $[h_{31}\ h_{32}]^T$  of the H matrix can be computed by dividing each receive vector ( $[r_{11}\ r_{12}]^T$ ,  $[r_{21}\ r_{22}]^T$  and  $[r_{31}\ r_{32}]^T$ , the receive output of the antennas at the STA) by s since the transmit symbol s is known at the STA because the STA will know the symbols used by the AP for the training sequence.

Using the method described above, a communication device may store the optimum transmit weight vectors for each of the other communication devices it communicates with. For example, an AP maintains a table mapping the MAC address for each STA to the optimum Tx weight vector for that STA. CBF-capable STAs may also store a table of such information when supporting communication in a peer-peer or ad-hoc network. All transmit weight vectors may be initially set to  $[1\ 0\ \dots\ 0]^T$ .

For a 4-CBF scheme (4 antennas at the AP) using 1500 byte packets at 54 Mbps, the loss in throughput for the above approach is approximately 8%. The loss in throughput could be made smaller using the following enhancements: one symbol long preambles instead of 2 in the training sequence; use the channel response training sequence only when it is needed; and/or transmitting the training sequence during the IEEE 802.11 SIFS interval.

The training sequence scheme described above can be applied to generate frequency dependent antenna weights. Steps 1010 through 1030 are repeated for each of a plurality of frequencies. For example, in the multi-carrier signal case,

steps 1010 through 1040 are repeated K times, for each sub-carrier frequency.

Similarly, for a single carrier modulation scheme, the training sequence would be applied for each of a plurality of frequency sub-bands that span the bandwidth of the baseband signal to be transmitted. In addition, the transmit weights can be  
5 frequency shaped so that the sum of the power across all of the antennas at a given frequency is constant.

The antenna processing techniques described herein can be incorporated into devices in a variety of ways. For example, an RF chip can be built that supports 2 Tx/Rx antenna ports, and one baseband chip that supports 2 x to 4 x  
10 CBF. One RF chip together with one baseband chip can be used in a network interface card, and two RF chips together with one baseband chip can be used in an AP for a system that supports 4-CBF at an AP, and 2-CBF in a STA. This system will perform up to 12 dB better than current state-of-the-art system.

From simulations for 2-antenna selection diversity in an indoor office  
15 environment w/50 ns RMS delay spread, 8 dB (4 dB) SNR is required for 802.11a (802.11b) at the lowest data rate. Including 6 dB of additional path loss for 802.11a at 5 GHz, a total of  $6+8-4 = 10$  dB of additional received signal power is required for 802.11a. For a path loss coefficient of 3.3 (indoor environment), 10 dB of additional signal power corresponds to  $\frac{1}{2}$  the range.

20 In addition, the antenna processing schemes described herein help reduce the performance degradation caused by interference. It has been shown through simulations that the interference immunity for a CBF-enhanced 802.11b network is approximately 2.2 times that of a non-CBF network. In other words, a CBF enhanced communication between two devices permits an interference source to be  
25 2.2 times close to a receiving device without degrading reception performance at that device.

To again summarize, the antenna processing techniques described above provide up to a 14 dB (25x) SNR improvement over existing 802.11a/b implementations without requiring a change to the communication protocol or  
30 standard. Moreover, compared to current 2-antenna implementations, these techniques provide nearly three times more range per AP; 7.3 times more coverage area; four times less infrastructure cost at a fixed throughput per user; 7-10 times



less infrastructure cost when optimized for coverage; 5 times more throughput per user at a fixed infrastructure cost; normalized and improved range for dual-mode 802.11a/b networks; and better interference immunity and higher data rates. As much as 10 times fewer APs are required to support a similar coverage area when  
5 CBF-enhanced APs are used.

To summarize, a method is provided that accomplishes communication between a first communication device and a second communication device using radio frequency (RF) communication techniques, comprising steps of applying a transmit antenna vector to a baseband signal to be transmitted from the first  
10 communication device to the second communication device, the transmit antenna weight vector comprising a complex transmit antenna weight for each of the N plurality of antennas, wherein each complex transmit antenna weight has a magnitude and a phase whose values may vary with frequency across a bandwidth of the baseband signal, thereby generating N transmit signals each of which is  
15 weighted across the bandwidth of the baseband signal; receiving at the N plurality of antennas of the first communication device a signal that was transmitted by the second communication device; determining a receive weight vector comprising a plurality of complex receive antenna weights for the N plurality of antennas of the first communication device from one or more signals received by the N plurality of  
20 antennas from the second communication device, wherein each receive antenna weight has a magnitude and a phase whose values may vary with frequency; and updating the transmit weight vector for the plurality of antennas of the first communication device for transmitting signals to the second communication device by computing a conjugate of the receive weight vector of the first communication  
25 device divided by a norm of the conjugate of the receive weight vector. This same method may be embodied in the form of instructions encoded on a medium or in a communication device.

Also provided is a method that accomplishes communication between a first communication device and a second communication device, comprising steps of  
30 transmitting a first signal by one of N plurality of antennas of the first communication device; receiving a first response signal at the plurality of antennas of the first communication device transmitted from a first of two antennas of the

second communication device; deriving a first row of a channel response matrix that describes the channel response between the first communication device and the second communication device; transmitting a second signal by the plurality of antennas of the first communication device using a transmit weight vector that is orthogonal to the first row of the channel response matrix; receiving a second response signal transmitted by a second of the two antennas of the second communication device and deriving therefrom a second row of the channel response matrix; and selecting one of the first and second rows of the channel response matrix that provides better signal-to-noise at the second communication device as the transmit weight vector for further transmission of signals to the second communication device. This same method may be embodied in the form of instructions encoded on a medium or in a communication device.

Still further provided is a method that accomplishes communication between first and second communication devices comprising steps of generating a training sequence comprising a sequence of  $N$  consecutive symbols, where  $N$  is a number of antennas of the first communication device, and the  $N$  symbols are multiplied by respective ones of  $N$  linearly independent vectors that span columns of a channel response matrix between the plurality of antennas of the first communication device and a plurality of antennas of the second communication device, thereby producing  $N$  transmit signals; transmitting the  $N$  transmit signals from the plurality of antennas of the first communication device; receiving the  $N$  transmit signals at each of a plurality of antennas at the second communication device; at the second communication device, deriving from signals received by the plurality of antennas the channel response matrix between the first communication device and the second communication device; and at the second communication device, generating a transmit weight vector from the channel response matrix for transmitting a signal from the second communication device to the first communication device using the plurality of antennas of the second communication device. This same method may be embodied in the form of instructions encoded on a medium or in a communication device.

The above description is intended by way of example only.

What is claimed is:

1. A method for communicating signals between a first communication device and a second communication device using radio frequency (RF) communication techniques, comprising:
  - a. applying a transmit antenna vector to a baseband signal to be transmitted from the first communication device to the second communication device, the transmit antenna weight vector comprising a complex transmit antenna weight for each of the N plurality of antennas, wherein each complex transmit antenna weight has a magnitude and a phase whose values may vary with frequency across a bandwidth of the baseband signal, thereby generating N transmit signals each of which is weighted across the bandwidth of the baseband signal;
  - b. receiving the N transmit signals at one or more antennas of the second communication device;
  - c. determining a receive weight vector comprising one or more complex receive antenna weights for the one or more antennas of the second communication device from the N transmit signals received by the one or more antennas, wherein each receive antenna weight has a magnitude and a phase whose values may vary with frequency across a bandwidth of the baseband signal;
  - d. computing a transmit weight vector comprising a plurality of complex transmit antenna weights for the one or more antennas of the second communication device by computing a conjugate of the receive weight vector divided by the norm of the receive weight vector; and
  - e. applying the transmit weight vector to a baseband signal to be transmitted from the second communication device to the first communication device, thereby generating one or more transmit signals each of which is weighted across the bandwidth of the baseband signal to be transmitted.
2. The method of claim 1, and further comprising steps of:

- f. receiving at the N plurality of antennas of the first communication device the one or more transmit signals transmitted by the second communication device;
  - g. determining a receive weight vector from the signals received by the N plurality of antennas; and
  - h. updating the transmit weight vector for the N plurality of antennas of the first communication device for transmitting signals to the second communication device by computing a conjugate of the receive weight vector of the first communication device divided by a norm of the conjugate of the receive weight vector.
3. The method of claim 2, and further comprising repeating steps (a) through (h) for a predetermined number iterations to converge to transmit weight vectors and receive weight vectors of the first and second communication devices that optimize a signal-to-noise ratio for communication between the first and second communication devices.
  4. The method of claim 1, wherein the step of determining the receive weight vector at the second communication device comprises matching the receive antenna weights to the received signal.
  5. The method of claim 1, wherein at substantially all frequencies of the baseband signal, the sum of the magnitude of the complex transmit antenna weights across the plurality of antennas of the first communication device is constant.
  6. The method of claim 2, and further comprising storing in the first communication device optimum transmit antenna weights indexed against an identifier for the second communication device.
  7. The method of claim 2, and further comprising storing in the first communication device optimum transmit antenna weights indexed against corresponding identifiers for each of a plurality of communication devices that the first communication device communicates with.
  8. The method of claim 1, wherein steps (a) through (e) are performed for each of K frequency sub-bands of the baseband signal that correspond to sub-

carriers of a multi-carrier baseband signal or to synthesized frequency sub-bands of a single carrier baseband signal.

9. The method of claim 8, and further comprising storing in the first communication device, for each of the N antennas, complex transmit antenna weights for a subset of the K frequency sub-bands or sub-carriers.
10. The method of claim 9, and further comprising retrieving the stored subset of complex transmit antenna weights and generating therefrom the complete set of antenna weights for all of the K frequency sub-bands or sub-carriers using interpolation techniques.
11. The method of claim 1, wherein the step of receiving the N transmit signals at the second communication device comprises receiving the N transmit signals at each of M plurality of antennas, the step of determining the receive weight vector comprises determining a receive antenna weight for each of the M plurality of antennas comprising a magnitude and phase component at each of the frequency sub-bands that span the bandwidth of the baseband signal that was received, and wherein the step of applying the transmit antenna vector to the baseband signal to be transmitted from the second communication device to the first communication device generates M plurality of transmit signals each of which is weighted across the bandwidth of the baseband signal.
12. The method of claim 1, wherein the step (a) of applying a transmit weight vector comprises applying a transmit weight vector  $[e^{-j2\pi f\tau_1}, e^{-j2\pi f\tau_2}, e^{-j2\pi f\tau_i}, \dots, e^{-j2\pi f\tau_N}]^T$ , for  $i = 1$  to N, where  $\tau_i$  is a time delay for antenna i, an initial packet to be transmitted from the first communication device to the second communication device.
13. A method for communicating signals between a first communication device and a second communication device using radio frequency (RF) communication techniques, comprising:
  - a. applying a transmit antenna vector to a baseband signal to be transmitted from the first communication device to the second communication device, the transmit antenna weight vector comprising a complex transmit antenna weight for each of the N plurality of antennas,

- wherein each complex transmit antenna weight has a magnitude and a phase whose values may vary with frequency across a bandwidth of the baseband signal, thereby generating N transmit signals each of which is weighted across the bandwidth of the baseband signal;
- b. receiving at the N plurality of antennas of the first communication device a signal that was transmitted by the second communication device;
  - c. determining a receive weight vector comprising a plurality of complex receive antenna weights for the N plurality of antennas of the first communication device from one or more signals received by the N plurality of antennas from the second communication device, wherein each receive antenna weight has a magnitude and a phase whose values may vary with frequency; and
  - d. updating the transmit weight vector for the plurality of antennas of the first communication device for transmitting signals to the second communication device by computing a conjugate of the receive weight vector of the first communication device divided by a norm of the conjugate of the receive weight vector.
14. The method of claim 13, wherein at substantially all frequencies of the baseband signal, the sum of the magnitude of the complex transmit antenna weights across the plurality of antennas of the first communication device is constant.
  15. The method of claim 13, wherein steps (a) through (d) are performed for each of K frequency sub-bands of the baseband signal that correspond to sub-carriers of a multi-carrier baseband signal or to synthesized frequency sub-bands of a single carrier baseband signal.
  16. The method of claim 15, and further comprising storing in the first communication device, for each of the N antennas, complex transmit antenna weights for a subset of the K frequency sub-bands or sub-carriers.
  17. The method of claim 16, and further comprising retrieving the stored subset of complex transmit antenna weights and generating therefrom the complete

set of antenna weights for all of the K frequency sub-bands or sub-carriers using interpolation techniques.

18. The method of claim 13, and further comprising storing in the first communication device optimum transmit antenna weights indexed against an identifier for the second communication device.
19. The method of claim 18, and further comprising storing in the first communication device optimum transmit antenna weights indexed against corresponding identifiers for each of a plurality of communication devices that the first communication device communicates with.
20. The method of claim 13, wherein the step (a) of applying a transmit weight vector comprises applying a transmit weight vector  $[e^{-j2\pi f\tau_1}, e^{-j2\pi f\tau_2}, e^{-j2\pi f\tau_i}, \dots, e^{-j2\pi f\tau_N}]^T$ , for  $i = 1$  to  $N$ , where  $\tau_i$  is a time delay for antenna  $i$ , an initial packet to be transmitted from the first communication device to the second communication device.
21. A medium encoded with instructions that, when executed, perform a method comprising steps of:
  - a. applying a transmit antenna vector to a baseband signal to be transmitted from a first communication device to a second communication device, the transmit antenna weight vector comprising a complex transmit antenna weight for each of the  $N$  plurality of antennas, wherein each complex transmit antenna weight has a magnitude and a phase whose values may vary with frequency across a bandwidth of the baseband signal, thereby generating  $N$  transmit signals each of which is weighted across the bandwidth of the baseband signal;
  - b. determining a receive weight vector comprising a plurality of complex receive antenna weights for the  $N$  plurality of antennas of the first communication device from one or more signals received by the  $N$  plurality of antennas from the second communication device, wherein each receive antenna weight has a magnitude and a phase whose values may vary with frequency; and
  - c. updating the transmit weight vector for the plurality of antennas of the first communication device for transmitting signals to the second

communication device by computing a conjugate of the receive weight vector of the first communication device divided by a norm of the conjugate of the receive weight vector.

22. The medium of claim 21, and further comprising instructions for performing steps (a) through (c) at each of K frequency sub-bands of the baseband signal that correspond to sub-carriers of a multi-carrier baseband signal or to synthesized frequency sub-bands of a single carrier baseband signal.
23. The medium of claim 22, and further comprising instructions for storing in the first communication device, for each of the N antennas, complex transmit antenna weights for a subset of the K frequency sub-bands or sub-carriers.
24. The medium of claim 23, and further comprising instructions for retrieving the stored subset of complex transmit antenna weights and generating therefrom the complete set of antenna weights for all of the K frequency sub-bands or sub-carriers using interpolation techniques.
25. The medium of claim 21, and further comprising instructions for setting the magnitude of the complex transmit antenna weights such that at substantially all frequencies of the baseband signal, the sum of the power across the plurality of antennas of the first communication device is constant.
26. The medium of claim 21, wherein the instructions for applying a transmit weight vector to a baseband signal to be transmitted from the first communication device to the second communication device comprises instructions for applying a transmit weight vector  $[e^{-j2\pi f\tau_1}, e^{-j2\pi f\tau_2}, e^{-j2\pi f\tau_i}, \dots, e^{-j2\pi f\tau_N}]^T$ , for  $i = 1$  to N, where  $\tau_i$  is a time delay for antenna  $i$ , an initial packet to be transmitted from the first communication device to the second communication device.
27. The medium of claim 21, wherein instructions encoded on the medium define digital logic gates that perform steps (a) through (c).



28. The medium of claim 21, wherein the instructions are processor readable instructions, that when executed by a processor, cause the processor to perform steps (a) through (c).
29. An integrated circuit comprising the medium of claim 21.
30. In combination, the integrated circuit of claim 29, and further comprising a processor that executes the instructions encoded on the medium.
31. A communication device comprising the medium of claim 21, and further comprising:
  - a. a transmitter that upconverts transmit signals for transmission;
  - b. a receiver that downconverts received signals; and
  - c. a processor coupled to the transmitter and to the receiver that processes instructions encoded on the medium.
32. A method for communicating signals from a first communication device to a second communication device using radio frequency (RF) communication techniques, comprising:
  - a. transmitting a first signal by one of N plurality of antennas of the first communication device;
  - b. receiving the first signal transmitted by the first communication device at two antennas of the second communication device;
  - c. transmitting a first response signal from the second communication device to the first communication device using a first of two antennas at the second communication device;
  - d. at the first communication device, receiving at the plurality of antennas the first response signal transmitted by the first antenna of the second communication device and deriving therefrom a first row of a channel response matrix that describes the channel response between the first communication device and the second communication device;
  - e. transmitting a second signal by the plurality of antennas of the first communication device using a transmit weight vector that is orthogonal to the first row of the channel response matrix;
  - f. receiving the second signal transmitted at the second communication device at the two antennas;

- g. transmitting a second response signal from the second communication device using a second of the two antennas;
  - h. at the first communication device, receiving the second response signal transmitted by the second antenna of the second communication device and deriving therefrom a second row of the channel response matrix; and
  - i. at the first communication device, selecting one of the first and second rows of the channel response matrix that provides better signal-to-noise at the second communication device as the transmit weight vector for further transmission of signals to the second communication device.
33. The method of claim 32, and further comprising the step of computing a norm of each row of the channel response matrix, and wherein the step of selecting comprises selecting the row that has the greater norm.
34. The method of claim 32, wherein the steps (a) through (i) are performed at each of a plurality of frequencies corresponding to sub-carrier frequencies of a multi-carrier baseband signal or synthesized frequency sub-bands of a single carrier baseband signal.
35. The method of claim 34, and further comprising storing in the first communication device, for each of the N antennas, complex transmit antenna weights for a subset of the frequency sub-bands or sub-carriers.
36. The method of claim 35, and further comprising retrieving the stored subset of complex transmit antenna weights and generating therefrom the complete set of antenna weights for all of the frequency sub-bands or sub-carriers using interpolation techniques.
37. The method of claim 32, wherein the second communication device selects one of the two antennas for transmitting signals to the first communication device based on which of the two antennas more strongly received a signal from the first communication device.
38. The method of claim 32, wherein the step of transmitting the second signal from the first communication device to the second communication device using a transmit weight vector that is orthogonal to the row of the channel response matrix forces the second communication device to select the

second antenna based on received signal strength at each of two antennas of second communication device.

39. The method of claim 32, wherein at substantially all frequencies of the baseband signal, the magnitude of the complex transmit antenna weights are such that the sum of the power across the plurality of antennas of the first communication device is constant.
40. A method for communicating signals from a first communication device to a second communication device using radio frequency (RF) communication techniques, comprising:
  - a. transmitting a first signal by one of N plurality of antennas of the first communication device;
  - b. receiving a first response signal at the plurality of antennas of the first communication device transmitted from a first of two antennas of the second communication device;
  - c. deriving a first row of a channel response matrix that describes the channel response between the first communication device and the second communication device;
  - d. transmitting a second signal by the plurality of antennas of the first communication device using a transmit weight vector that is orthogonal to the first row of the channel response matrix;
  - e. receiving a second response signal transmitted by a second of the two antennas of the second communication device and deriving therefrom a second row of the channel response matrix; and
  - f. selecting one of the first and second rows of the channel response matrix that provides better signal-to-noise at the second communication device as the transmit weight vector for further transmission of signals to the second communication device.
41. The method of claim 40, and further comprising the step of determining when a signal received at the first communication device from the second communication device indicates at least a minimum difference in a row of the channel response matrix, and repeating steps (a)-(f) in response thereto.

42. The method of claim 40, and further comprising the step of computing a norm of each row of the channel response matrix, and wherein the step of selecting comprises selecting the row that has the greater norm.
43. The method of claim 40, wherein the steps (a) through (f) are performed at each of a plurality of frequencies corresponding to sub-carrier frequencies of a multi-carrier baseband signal or synthesized frequency sub-bands of a single carrier baseband signal.
44. The method of claim 43, and further comprising storing in the first communication device, for each of the N antennas, complex transmit antenna weights for a subset of the frequency sub-bands or sub-carriers.
45. The method of claim 43, and further comprising retrieving the stored subset of complex transmit antenna weights and generating therefrom the complete set of antenna weights for all of the frequency sub-bands or sub-carriers using interpolation techniques.
46. The method of claim 40, wherein at substantially all frequencies of the baseband signal, the magnitude of the complex transmit antenna weights are such that the sum of the power across the plurality of antennas of the first communication device is constant.
47. A medium encoded with instructions that, when executed, perform steps of:
  - a. generate a first signal for transmission by one of a plurality of antennas of a first communication device to a second communication device;
  - b. process a first response signal received at the plurality of antennas that was transmitted from a first of two antennas of the second communication device and generating a first row of a channel response matrix that describes the channel response with the other communication device;
  - c. applying to a second signal a transmit weight vector that is orthogonal to the first row of the channel response matrix for transmission via the plurality of antennas of the first communication device to the second communication device;
  - d. processing a second response signal received at the plurality of antennas that was transmitted from a second of two antennas of the second

communication device and generating therefrom a second row of the channel response matrix; and

- e. selecting one of the first and second rows of the channel response matrix that provides better signal-to-noise at the second communication device as the transmit weight vector for further transmission of signals to the other communication device.
48. The medium of claim 47, and further comprising instructions to compute a norm of each row of the channel response matrix, and select the row that has the greater norm as the transmit weight vector.
  49. The medium of claim 47, wherein the instructions perform steps (a) through (e) are performed at each of a plurality of frequencies corresponding to sub-carrier frequencies of a multi-carrier baseband signal or synthesized frequency sub-bands of a single carrier baseband signal.
  50. The medium of claim 47, wherein the instructions encoded on the medium define digital logic gates that perform steps (a) through (e).
  51. The medium of claim 47, wherein the instructions are processor readable instructions, that when executed by a processor, cause the processor to perform steps (a) through (e).
  52. A communication device comprising the medium of claim 47, and further comprising:
    - a. a transmitter that upconverts signals to be transmitted;
    - b. a receiver that downconverts received signals;
    - c. a processor coupled to the transmitter and to the receiver that processes the instructions encoded on the medium.
  53. An integrated circuit comprising the medium of claim 47.
  54. The integrated circuit of claim 47, and further comprising a processor that executes the instructions encoded on the medium.
  55. A method for communicating signals between a first communication device and a second communication device using radio frequency (RF) communication techniques, comprising:
    - a. generating a training sequence comprising a sequence of N consecutive symbols, where N is a number of antennas of the first communication

- device, and the  $N$  symbols are multiplied by respective ones of  $N$  linearly independent vectors that span columns of a channel response matrix between the plurality of antennas of the first communication device and a plurality of antennas of the second communication device, thereby producing  $N$  transmit signals;
- b. transmitting the  $N$  transmit signals from the plurality of antennas of the first communication device;
  - c. receiving the  $N$  transmit signals at each of a plurality of antennas at the second communication device;
  - d. at the second communication device, deriving from signals received by the plurality of antennas the channel response matrix between the first communication device and the second communication device; and
  - e. at the second communication device, generating a transmit weight vector from the channel response matrix for transmitting a signal from the second communication device to the first communication device using the plurality of antennas of the second communication device.
56. The method of claim 55, and further comprising:
- a. appending the training sequence to a data unit for transmission from the first communication device to the second communication device;
  - b. transmitting the data unit with the appended training sequence by the antennas of the first communication device; and
  - c. at the second communication device, receiving the data unit and the appended training sequence and decoding the data unit.
57. The method of claim 55, wherein the step of appending the training sequence comprises appending the training sequence to a directed media access control (MAC) protocol data unit in accordance with the IEEE 802.11 communication standard.
58. The method of claim 55, wherein the step of generating the training sequence comprises generating  $N$  consecutive 2-symbol long preamble sequences in accordance with the IEEE 802.11 communication standard.

59. The method of claim 55, wherein the step of generating the transmit weight vector comprises updating the transmit weight vector for transmitting a signal to the first communication device.
60. The method of claim 55, and further comprising the step of storing at the second communication device information describing the transmit weight vector to be used for transmitting signals to the first communication device.
61. The method of claim 60, wherein the step of storing comprises storing at the second communication device information describing transmit weight vectors to be used for transmitting signals to each of a plurality of corresponding communication devices.
62. The method of claim 55, and further comprising the step of transmitting a message to the second communication device to determine whether the second communication device is capable of transmitting signals back to the first communication device using an adjustable transmit weight vector.
63. The method of claim 55, wherein steps (a) through (e) are performed at each of a plurality of frequencies corresponding to sub-carrier frequencies of a multi-carrier baseband signal or synthesized frequency sub-bands of a single carrier baseband signal so as to generate frequency dependent transmit antenna weights for the transmit weight vector.
64. The method of claim 55, wherein the step of generating the training sequence comprises applying to the N symbols respective ones of the transmit weight vectors  $[1\ 0\ \dots\ 0]_0^T$ ,  $[0\ 1\ 0\ \dots\ 0]_1^T$ , ...,  $[0\ 0\ \dots\ 1]_{N-1}^T$ .





FIG. 2

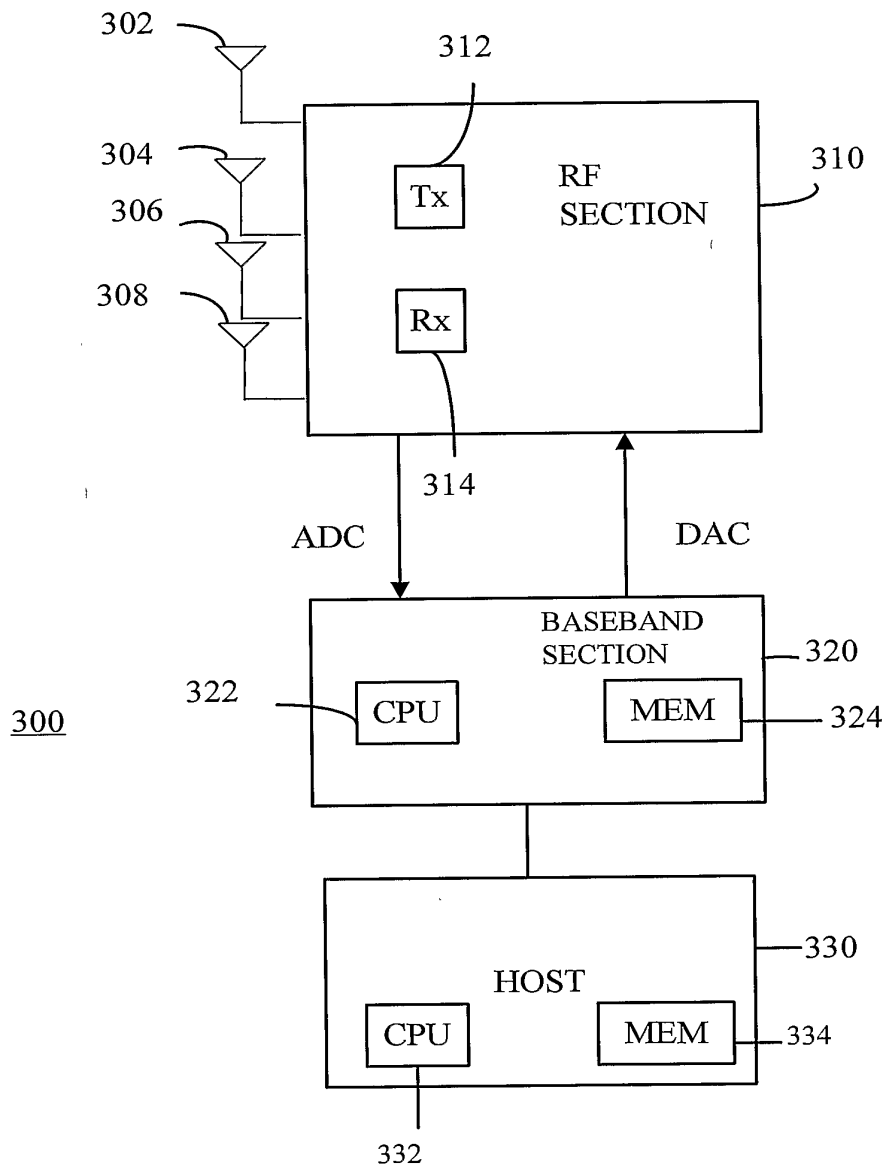


FIG. 3

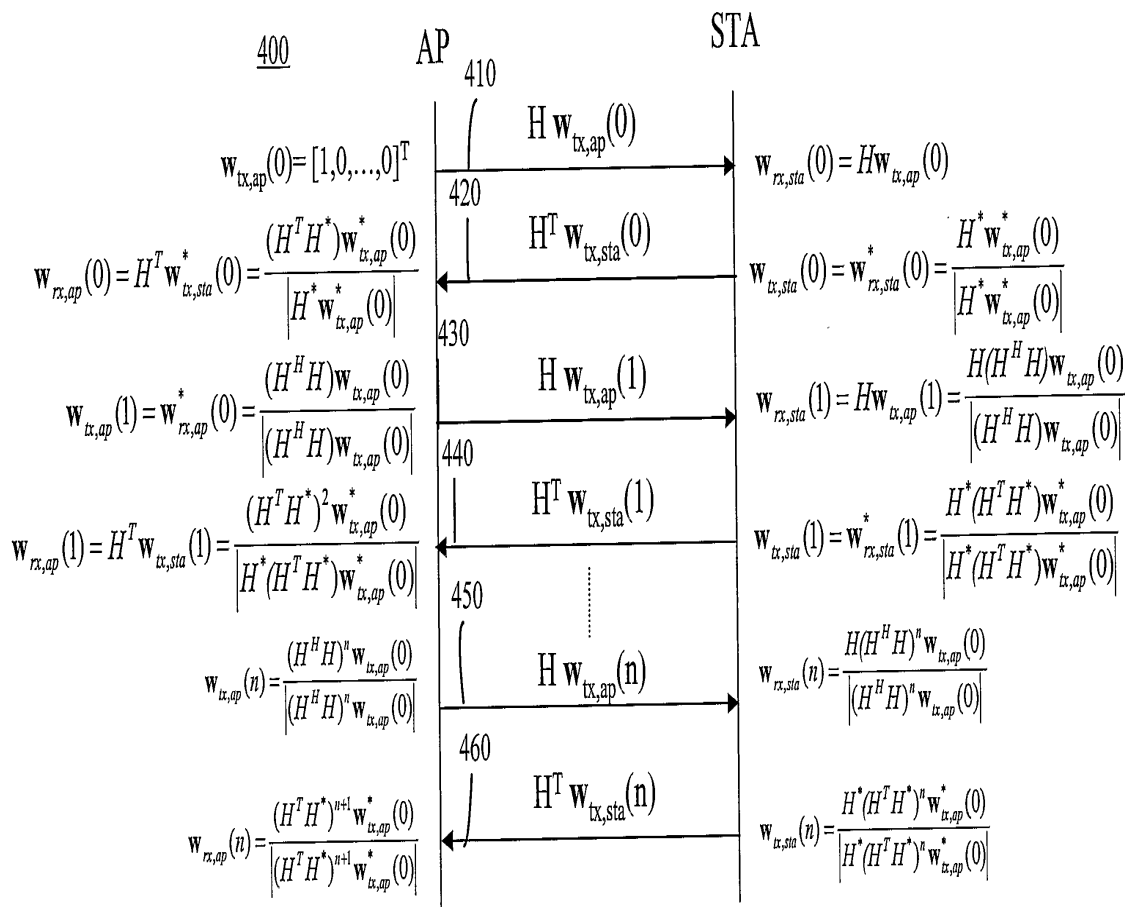


FIG. 4

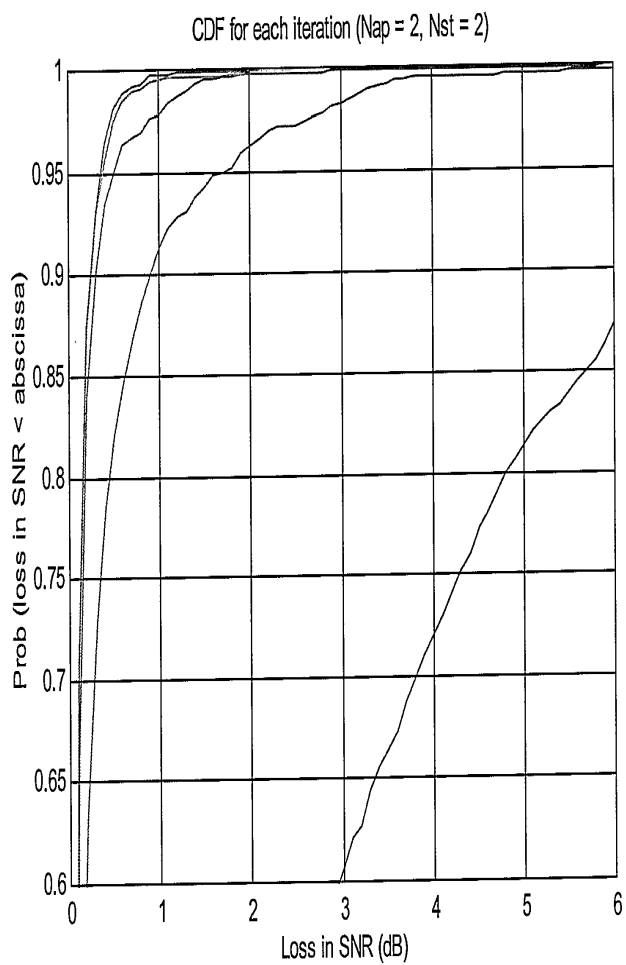


FIG. 5

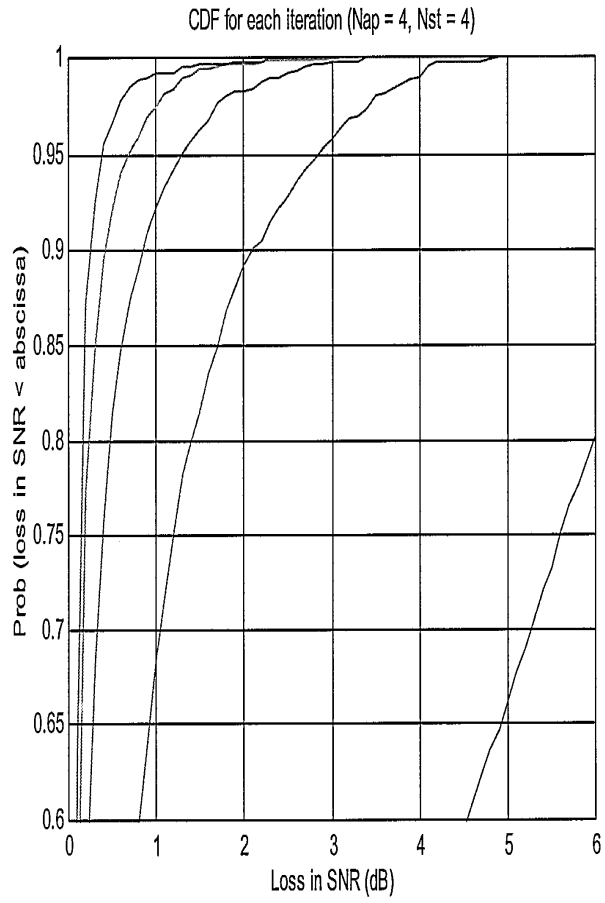
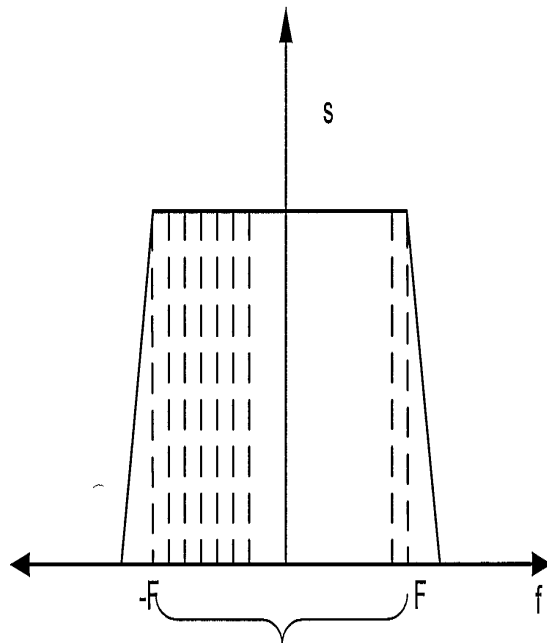


FIG. 6



$K$  sub-carriers of multi-carrier baseband signal  
 $K$  sub-bands of single-carrier baseband signal

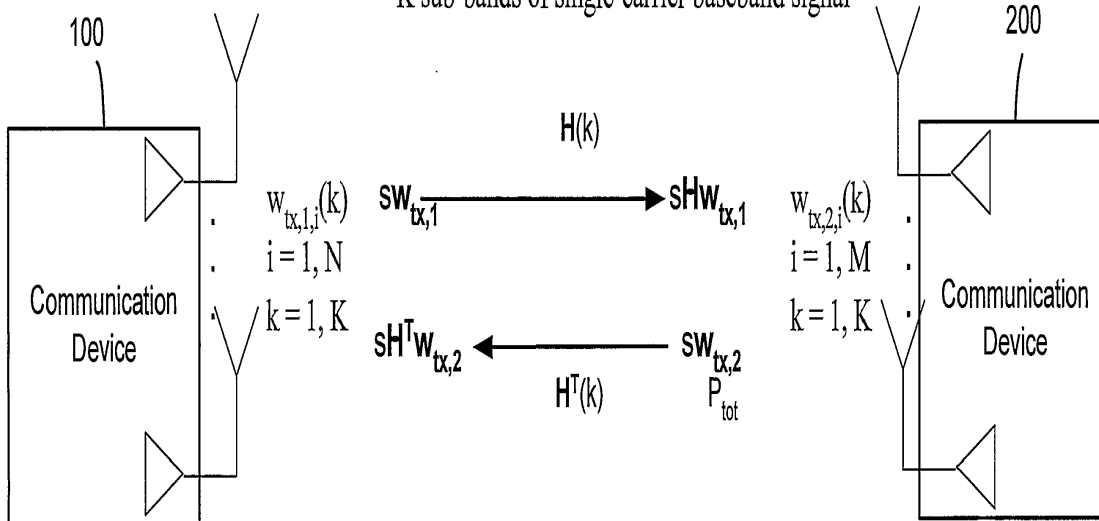
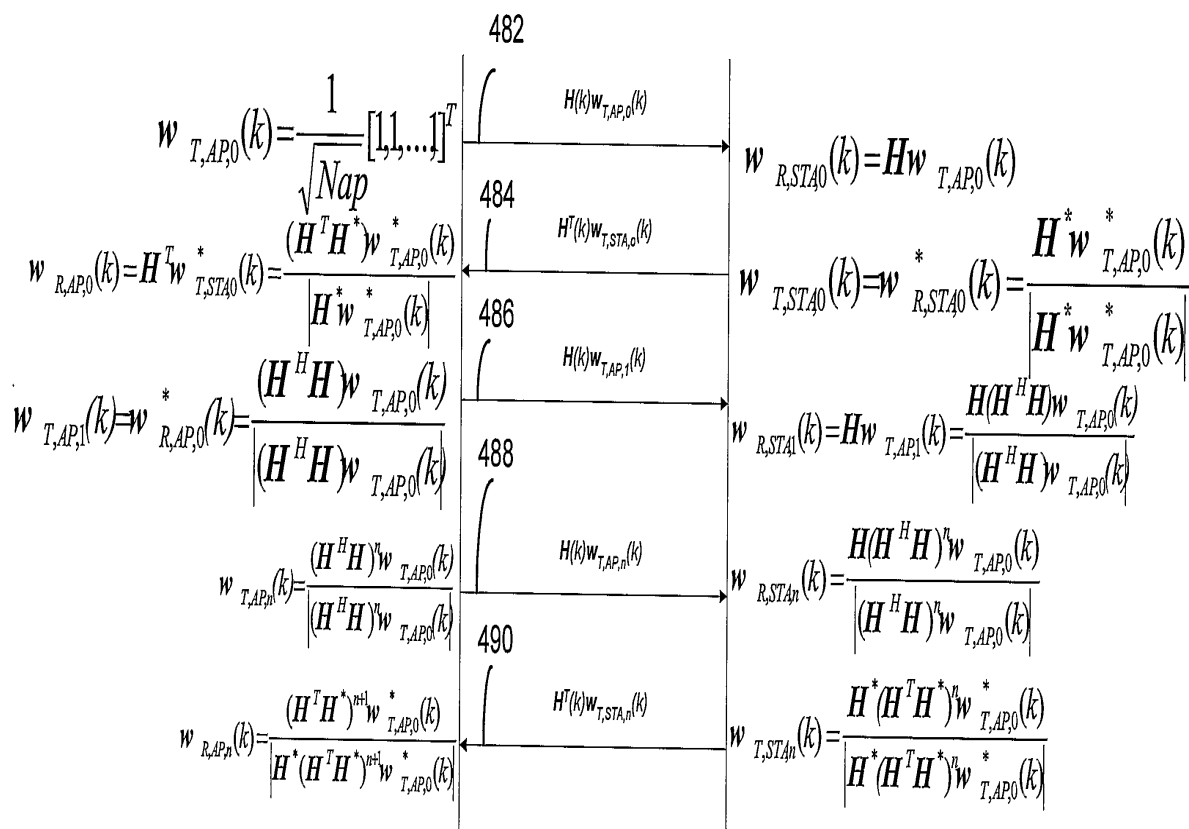


FIG. 7

480



7/13



FIG. 9

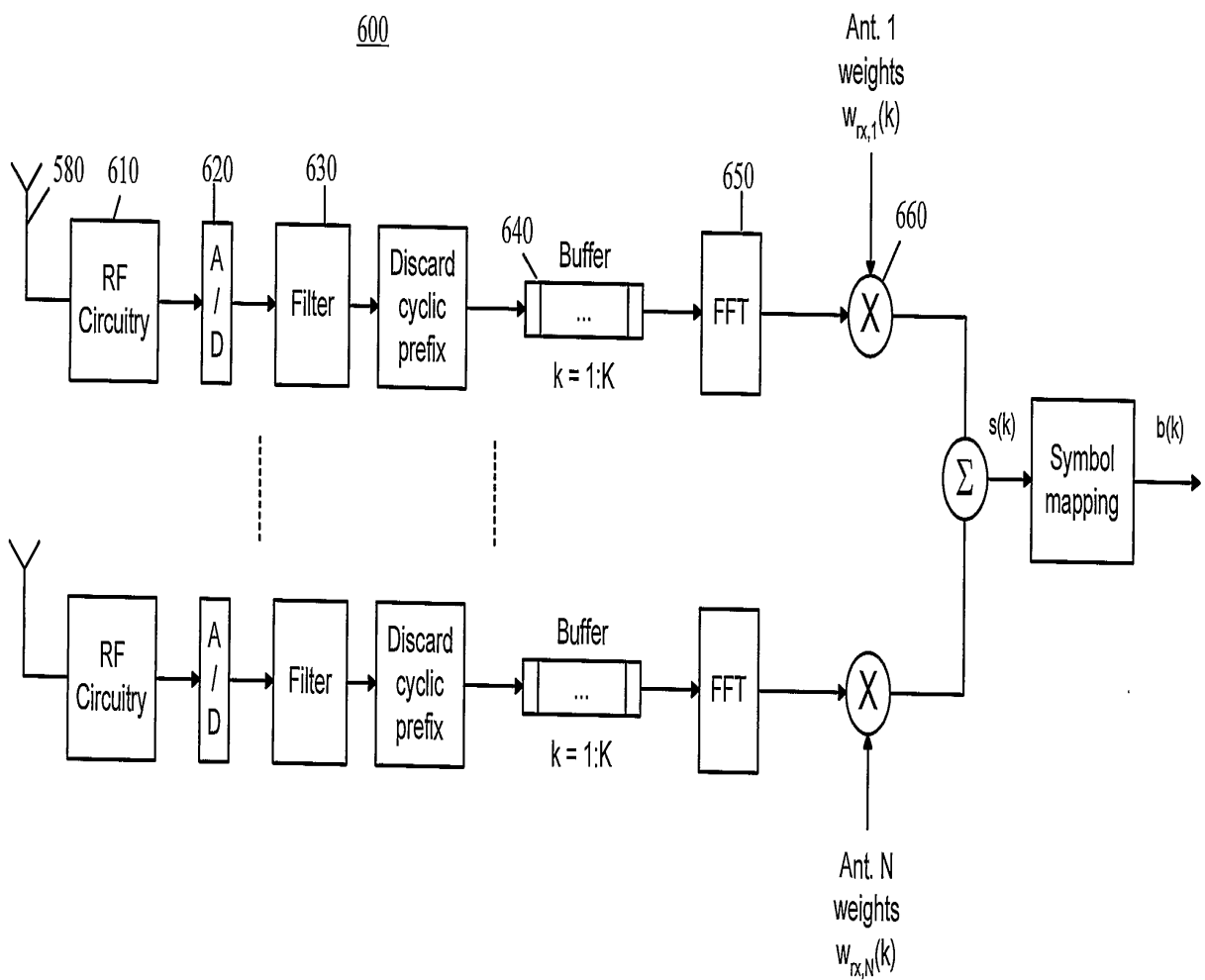




FIG. 10

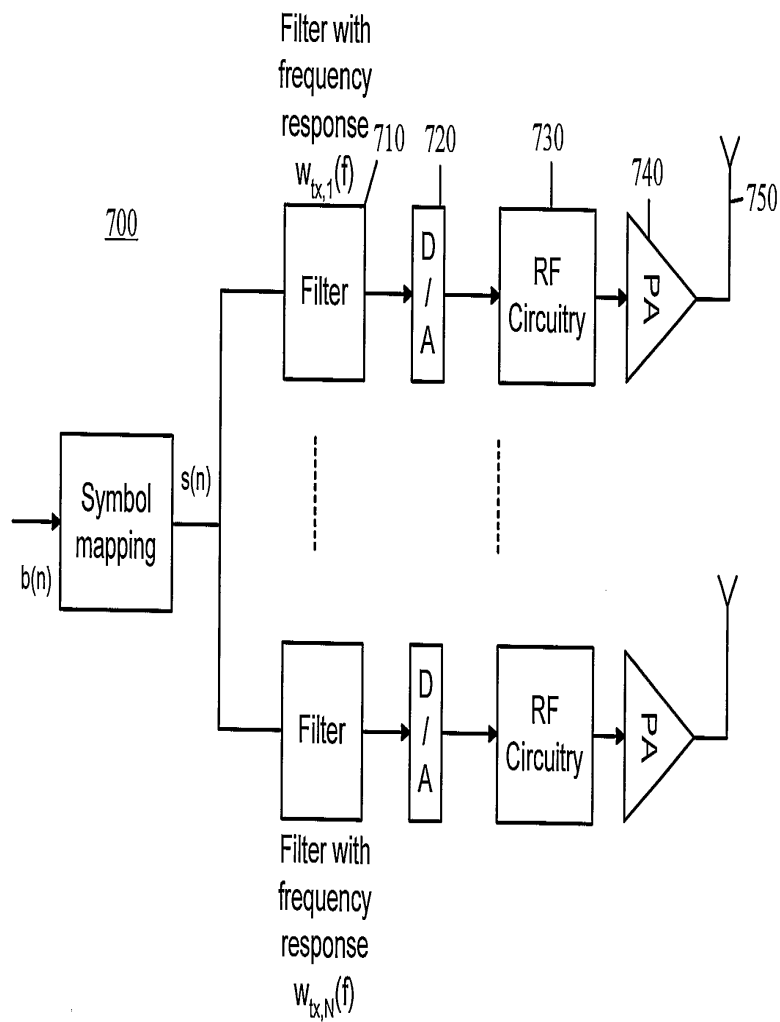


FIG. 11

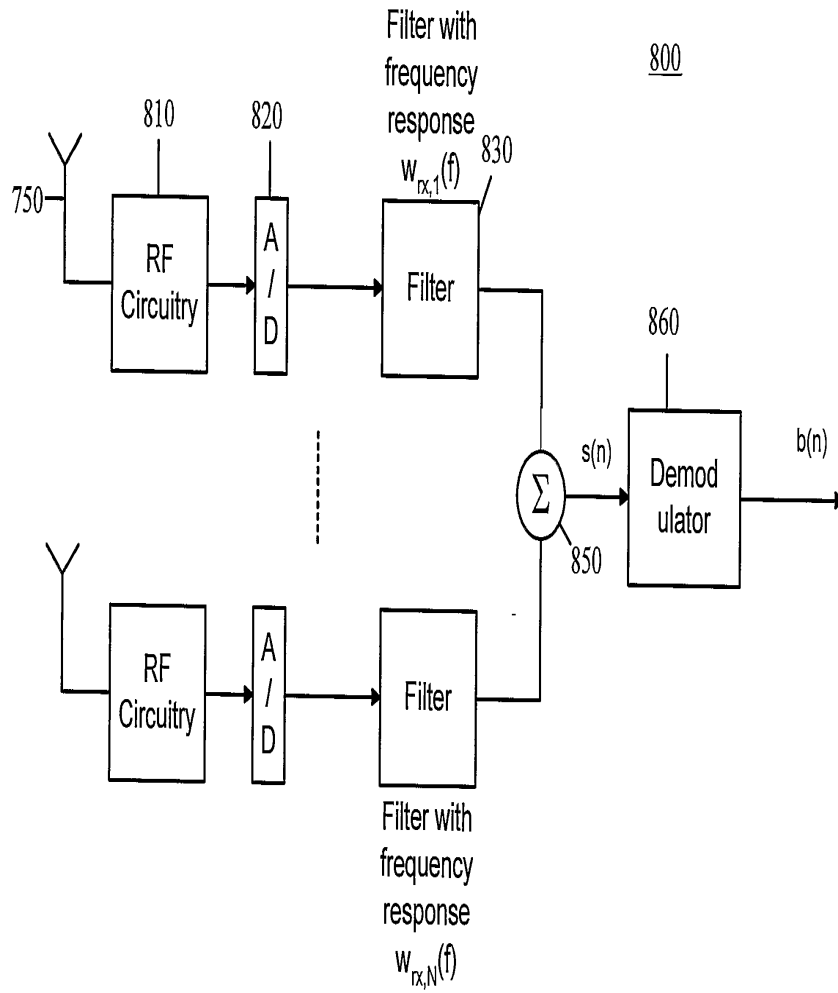
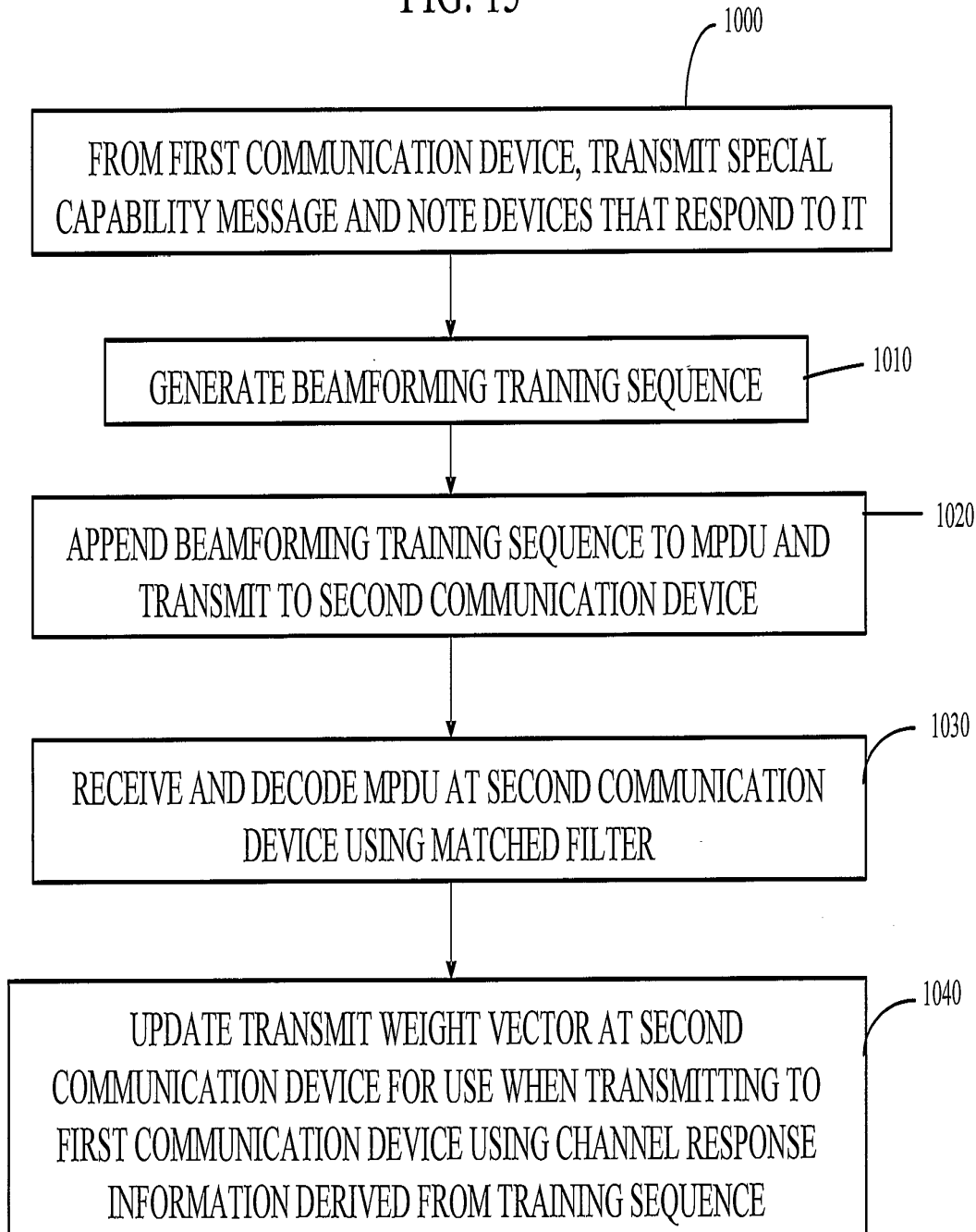




FIG. 13





**FOR THE PURPOSES OF INFORMATION ONLY**

Codes used to identify States party to the PCT on the front pages of pamphlets publishing international applications under the PCT.

AM	Armenia	GB	United Kingdom	MW	Malawi
AT	Austria	GE	Georgia	MX	Mexico
AU	Australia	GN	Guinea	NE	Niger
BB	Barbados	GR	Greece	NL	Netherlands
BE	Belgium	HU	Hungary	NO	Norway
BF	Burkina Faso	IE	Ireland	NZ	New Zealand
BG	Bulgaria	IT	Italy	PL	Poland
BJ	Benin	JP	Japan	PT	Portugal
BR	Brazil	KE	Kenya	RO	Romania
BY	Belarus	KG	Kyrgyzstan	RU	Russian Federation
CA	Canada	KP	Democratic People's Republic of Korea	SD	Sudan
CF	Central African Republic	KR	Republic of Korea	SE	Sweden
CG	Congo	KZ	Kazakhstan	SG	Singapore
CH	Switzerland	LI	Liechtenstein	SI	Slovenia
CI	Côte d'Ivoire	LK	Sri Lanka	SK	Slovakia
CM	Cameroon	LR	Liberia	SN	Senegal
CN	China	LT	Lithuania	SZ	Swaziland
CS	Czechoslovakia	LU	Luxembourg	TD	Chad
CZ	Czech Republic	LV	Latvia	TG	Togo
DE	Germany	MC	Monaco	TJ	Tajikistan
DK	Denmark	MD	Republic of Moldova	TT	Trinidad and Tobago
EE	Estonia	MG	Madagascar	UA	Ukraine
ES	Spain	ML	Mali	UG	Uganda
FI	Finland	MN	Mongolia	US	United States of America
FR	France	MR	Mauritania	UZ	Uzbekistan
GA	Gabon			VN	Viet Nam

ACTUATORS

This invention relates to actuators hereinafter referred to as actuators "of the kind specified" in which an annular piston defines an annular working chamber in combination with co-operating cylinder walls, the piston being axially displaceable relative to the cylinder walls by pressurisation of fluid within the working chamber.

Actuators of the kind specified are used for a variety of purposes but are particularly suitable for the actuation of a vehicle clutch release bearing when the actuator can be installed concentrically around a gearbox input shaft of the vehicle.

Problems arise with such actuators in that actuating fluid leaks past seals which seal the piston to the cylinder walls and can then contaminate the associated clutch. Also, on rapid movements of the piston, or sudden depressions in the fluid pressure in the working chamber, air may be drawn into the working chamber past the piston seals.

It is an object of the present invention to provide an actuator of the kind specified which is less susceptible to leakage and to the ingress of air.

Thus according to the present invention there is provided an

actuator of the kind specified having sealing means for sealing the piston to the cylinder walls, an overflow chamber which retains any fluid which leaks past the sealing means from the working chamber, and return means for returning fluid from the overflow chamber when the piston is not undertaking a working stroke.

The return means may comprise valve means which controls communication between the working chamber and over flow chamber, the valve means opening up communication between said chambers when the piston is not undertaking a working stroke.

Such an actuator is less susceptible to leakage and air ingress since the overflow chamber retains any fluid which leaks past the seals and the valve means enables the piston to suck back fluid into the working chamber from the overflow chamber instead of sucking in air.

The valve means may conveniently be built into the sealing means.

For example, pressurisation of the working chamber may cause deflection of the sealing means to close-off communication between the working and overflow chambers.

Alternatively the return means may comprise a valve means separate from the sealing means, said valve means being arranged to be normally biased to a closed position but



being opened on a return stroke of the piston following a working stroke.

The overflow chamber may be defined by diaphragm means in combination with the walls.

In an arrangement in which the piston is displaceable between inner and outer cylinder walls one diaphragm may extend between the piston and the inner cylinder wall and a second diaphragm may extend between the piston and the outer cylinder wall.

In an alternative arrangement the overflow chamber may be defined by a diaphragm means and a portion of the outer cylinder wall, passageway means being provided to direct any fluid which leaks past the sealing means to the overflow chamber.

Where the actuator is to be used to operate a vehicle clutch a clutch release bearing is carried by the piston.

Several embodiments of the present invention will now be described, by way of example, with reference to the accompanying drawings in which:-

Figure 1 is a radial section through an actuator according to the present invention for the operation of a vehicle clutch;

Figure 2 shows half of figure 1 on a larger scale with half

of the actuator seal shown in its open position and the other half in its closed position;

Figure 3 is a section on line III-III of Figure 1;

Figure 4 shows a similar view to Figure 2 with an alternative sealing/valve arrangement;

Figure 5 is a radial section through an alternative clutch actuator according to the invention which is constructed largely from plastics material;

Figure 6 is an enlarged view of the sealing/valve arrangement used in Figure 5, and

Figure 7 is a radial section through a further alternative clutch actuator which employs a separate return valve.

Referring to figure 1 this shows a vehicle clutch actuator in which an annular piston 10 is displaceable between an inner cylinder member 11 and an outer cylinder member 12. Piston 10 carries a clutch release bearing 13 which operates, for example, the diaphragm spring 14 of an associated clutch (not shown). A spring 30 acts between outer cylinder member 12 and release bearing 13 to maintain a pre-load on diaphragm spring 14.

Mounted on the left hand end of piston 10 is a combined sealing and valve member 15 which is held in position on

piston 10 by inner and outer sheet metal rings 16 and 17 which restrain a base portion 18 of the sealing member 15.

A head portion 19 of the sealing member 15 is disposed in a working chamber 20 defined by the sealing member and the inner and outer cylinder walls 11 and 12. Pressurised fluid may be admitted to working chamber 20 via an inlet 21 from an associated clutch operating master cylinder or other source of fluid pressure (not shown) in order to displace piston 10 to the right and hence disengage the associated clutch.

Extending between the piston 10 and the inner and outer cylinder members 11 and 12 are two rolling lobe diaphragms 22 and 23 respectively. A bead 22a of diaphragm 22 is secured to inner cylinder member 11 by an inner sheet metal ring 24 and a bead 23a of diaphragm 23 is secured to outer cylinder member 12 via an outer sheet metal ring 25.

Diaphragms 22 and 23 are constrained to move axially with piston 10 by portions 16a and 17a of rings 16 and 17 which entrap bead portions 22b and 23b of these diaphragms.

Thus overflow chambers 26 and 27 are defined by either side of piston 10.

Head portion 19 of sealing member 15 is provided with axially extending openings 28 through which fluid can flow from working chamber 20 into and out of overflow chambers 26

and 27 along flow paths X shown open in the bottom half of figure 1 and also in the top half of the seal arrangement of figure 2. As can be seen from figure 2, flow paths X are via flutes 22c and 23c in the outer surface of diaphragms 22 and 23.

When the pressure within working chamber 20 increases in order to move piston 10 to the right to operate diaphragm spring 14, the pressure in working chamber 20 displaces the sealing member 15 to the right relative to piston 10 so that the base portion 18 of sealing member 15 occupies the position shown in the top half of figure 1 in which sealing surfaces 29 on the head portion 19 of the sealing member close-off flow path X by contact with the adjacent portions of rings 16 and 17. The ability of sealing member 15 to move to the right is ensured by passages 10a in piston 10 which place chamber 10b beneath the base portion 18 of sealing member 15 in communication with the atmosphere.

Thus when piston 10 is being displaced to the right whilst undertaking a working stroke the communication between working chamber 20 and overflow chamber 26 and 27 is closed-off so that diaphragms 22 and 23 are not exposed to the full operating pressure within working chamber 20.

When the working pressure in chamber 20 is released and the piston 10 is retracted, sealing member 15 assumes the non-deformed condition shown in the lower half of figure 1 in which communication between overflow chambers 26 and 27 and

working chamber 20 is again restored so that any fluid which has leaked into overflow chambers 26 and 27 around the head portion of sealing member 15 can flow back into working chamber 20. As will be appreciated, should piston 10 make any rapid movement, or a rapid depression in working chamber pressure occur, which might tend to draw air into working chamber 20, this will then simply result in fluid being sucked into working chamber 20 from overflow chambers 26 and 27.

In normal operation of the actuator overflow chambers 26 and 27 are full of actuating fluid and any leakage of fluid past sealing member 15 during a given working stroke of piston 10 is accommodated by slight stretching of the diaphragms 22 and 23. This fluid which has leaked past sealing member 15 is returned to working chamber 20 on the next opening of flow paths X when chamber 20 is depressurised.

Figure 3 shows the manner in which rotation of piston 10 relative to outer cylinder member 12 is prevented. As can be seen from figure 3, an outer sheet metal guide member 31 is secured to the outer race 13a of release bearing 13 which is also non-rotatably secured to piston 10. Guide member 31 is provided with castellations 32 which engage legs 33 formed on an outer plastics sleeve member 34 which is secured to outer cylinder member 12 via rolled proportion 12a. The total axial displacement of release bearing 13 is also controlled by tangs 35 formed in guide member 31 which extend into slots 36 in legs 33.

Figure 4 shows an alternative sealing arrangement in which annular piston 10 carries a sealing member 40 which is retained on piston 10 by an annular retaining member 41 which is an interference fit in an annular groove 42 in piston 10. Retaining member 41 also retains diaphragm gripping rings 42 and 43 in position on piston 10.

As can be seen from figure 4, sealing member 40 is provided with two sealing lips 46 and 47 for engagement with cylinder members 11 and 12 respectively.

The lip 47 is shown in figure 4 in its undeflected condition which it occupies when the fluid pressure in the working chamber 20 is low. When the pressure in chamber 20 is increased in order to move piston 10 to the right the seal 40 and its lips 46 and 47 are deflected by the fluid pressure to the position shown occupied by the lip 46 in figure 4. This seals off the communication between overflow chambers 26 and 27 so that the diaphragms 22 and 23 are again not subjected to the full pressure developed in working chamber 20. The ability of seal 40 to deflect is ensured by connecting chamber 10b beneath seal 40 to atmosphere via clearances 10a between piston 10 and retaining member 41.

As can clearly be seen from figure 4, the portions of diaphragms 22 and 23 are provided with axially extending flutes 22c and 23c which promote communication between working chamber 20 and the associated overflow chamber 26

and 27. Flow around sealing member 40 when lips 46 and 47 are not sealing is facilitated by flutes 46a and 47a in sealing member 40.

Figures 5 and 6 show an alternative actuator construction which is manufactured primarily from plastics material and in which the clutch release bearing 50 is carried on an annular plastics piston 51 which is axially displaceable between inner and outer cylinder walls 52 and 53 respectively. Walls 52 and 53 are formed integrally with a main body portion 54 of the actuator which also includes an integral fluid inlet 55.

A compression spring 56 again acts between the release bearing 50 and the main body portion 54 of the actuator to provide the desired diaphragm spring pre-load.

Piston 51 carries annular sealing member 58 (see figure 6) which has retaining lobes 59 which engage in grooves 60 in the piston. Sealing member 58 includes sealing lips 61 and 62 for engagement with the inner and outer cylinder portions 52 and 53 respectively. The upper portion of figure 6 shows lip 62 in its unpressurised condition in which flow is possible from working chamber 63 down the clearances between piston 51 and cylinder members 52 and 53 into an overflow chamber 65 defined between a diaphragm 66 and the outer cylinder member 53. Communication between working chamber 63 and overflow chamber 65, as indicated above, is via the clearances between piston 51 and the cylinder members 52 and

53 and also via passageway 67 provided in outer cylinder member 53 and cross drillings 68 in piston 51. Secondary annular seals 70 and 71 seal the outer ends of the clearances between piston 51 and cylinder members 52 and 53.

Again flow around the sealing member 58 when the lips 61 and 62 are not sealing is facilitated by flutes 61a and 62a formed in the sealing member 58.

When working chamber 63 is pressurised sealing member 58 is deflected to the position shown in the bottom half of figure 6 in which the lips 61 and 62 seal against the cylinder members 52 and 53 to cut-off communication with the overflow chamber 65. The ability of sealing member 58 to deflect is ensured by passage 51a in piston 51 which connects chamber 51b behind sealing member 58 with atmosphere.

Figure 7 shows a further actuator construction in which both metals and plastics materials are used. In this construction a clutch release bearing 80 is secured on an annular plastics piston 81 which is axially displaceable between an inner metal cylinder wall 82 and an outer plastics cylinder wall 83. Walls 82 and 83 are sealed together by a seal 84 and wall 83 includes an integral fluid inlet 85.

Piston 81 is sealed at the bearing end to walls 82 and 83 by seals 86 and 87 respectively. A main seal 88 acts as the primary seal for working chamber 90. An overflow chamber 91



is defined by a diaphragm 92 whose natural shape is as shown in figure 7. The ends of the diaphragm 92 are received in grooves 93 and 94 provided in outer plastics cylinder wall 83. Any fluid which leaks past main seal 88 is fed to overflow chamber 91 via drillings 95 and 96.

Fluid within overflow chamber 91 can be returned to working chamber 90 and hence to fluid inlet 85 via a one way valve 97. Valve 97 is lightly loaded to its closed position by spring 98 and is opened either by the occurrence of a depression in working chamber 90 and/or by force applied to the stem 99 of valve 97 by a ring 100 as a result of atmospheric pressure acting on diaphragm 92 as indicated by arrows P in figure 7.

Thus figure 7 is an example of a construction in which the valve means which controls communication with the overflow chamber 91 does not form part of the main seal 88.

All the actuators described above may form part of a pre-filled clutch hydraulic system of the form described in, for example, earlier US patents Nos. 4407125, 4599860, 4624290 and 5113657 in which the system is pre-filled with hydraulic fluid before being fitted on the associated vehicle. Alternatively the actuators may be filled after mounting on the vehicle.

The actuators are conveniently filled by being subjected to a vacuum to evacuate air followed by the introduction of

hydraulic fluid under pressure. The presence in each actuator shown in figures 1 to 3 or 4 or 5 or 6 of passages 10a which admit atmospheric pressure to chamber 10b helps to ensure that valve member 15 assume its open position so that flow path X is maintained open during the filling process thus ensuring that the overflow chambers are fully evacuated and filled.

In the Figure 7 construction valve 97 is held open during filling both by the depression created in the working chamber 90 during evacuation of air and by the atmospheric pressure P acting on diaphragm 92 and hence on valve stem 99 via ring 100 during the initial introduction of hydraulic fluid under pressure.

CLAIMS

1. An actuator of the kind specified having sealing means for sealing the piston to the cylinder walls, an overflow chamber which retains any fluid which leaks past the sealing means from the working chamber, and return means for returning fluid from the overflow chamber when the piston is not undertaking a working stroke.
2. An actuator according to claim 1 in which the return means comprises valve means which controls communication between the working chamber and overflow chamber, the valve means opening up communication between said chambers when the piston is not undertaking a working stroke.
3. An actuator according to claim 2 in which the valve means is built into the sealing means.
4. An actuator according to claim 3 in which pressurisation of the working chamber causes deflection of the sealing means to close off communication between the working and overflow chambers.
5. An actuator according to any one of claims 1 to 4 in

which the annular piston is displaceable between inner and outer cylinder walls and an annular sealing means contacts said walls to seal the working chamber and is axially displaceable relative to the piston when the working chamber is pressurised to move the piston, said axial movement of the sealing means closing-off communication between the working and overflow chambers.

6. An actuator according to any one of claims 1 to 4 in which the annular piston is displaceable between inner and outer cylinder walls and the sealing means has inner and outer sealing lips which are pressed against the co-operating inner and outer walls respectively when the working chamber is pressurised thus sealing the working chamber and also to cutting off communication between the working and overflow chambers.
7. An actuator according to any one of claims 1 to 6 in which the overflow chamber is defined by diaphragm means in combination with the cylinder walls.
8. An actuator according to claim 7 in which the piston is displaceable between inner and outer cylinder walls with one diaphragm extending between the piston and the inner cylinder wall and a second diaphragm extending between the piston and the outer cylinder wall.

9. An actuator according to claim 7 in which the piston is displaceable between inner and outer cylinder walls and the overflow chamber is defined by the diaphragm means and a portion of the outer cylinder wall, passageway means being provided to direct any fluid which leaks past the sealing means to the overflow chamber.
10. An actuator according to claim 9 in which the piston and cylinder walls are made from plastics material.
11. An actuator according to any one of claims 1 to 10 in which rotation of the piston relative to the cylinder wall is prevented by a guide means which is operatively associated with the piston and which engages an anti-rotation formation associated with the cylinder walls.
12. An actuator according to claim 1 or claim 9 when dependent on claim 1 in which the return means comprises valve means separate from the sealing means, said valve means being arranged to be normally biased to a closed position but being opened on a return stroke of the piston following a working stroke.
13. An actuator according to any one of claims 1 to 12 for the operation of a vehicle clutch, the actuator including a clutch release bearing carried by the piston.

14. An actuator constructed and arranged substantially as hereinbefore described with reference to and as shown in figures 1 to 3 or 4 or 5 and 6 or 7 of the accompanying drawings.



2/6

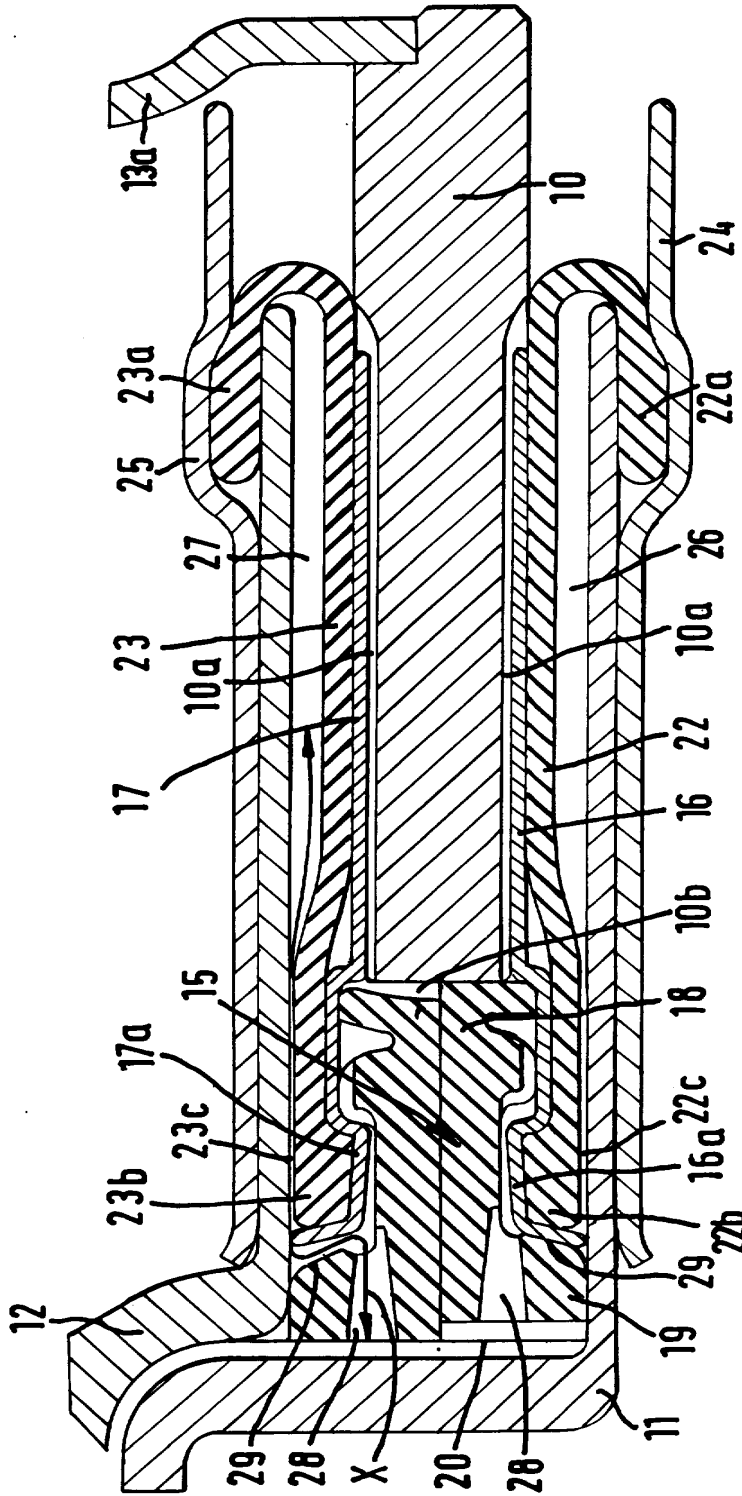


FIG. 2

SUBSTITUTE SHEET (RULE 26)



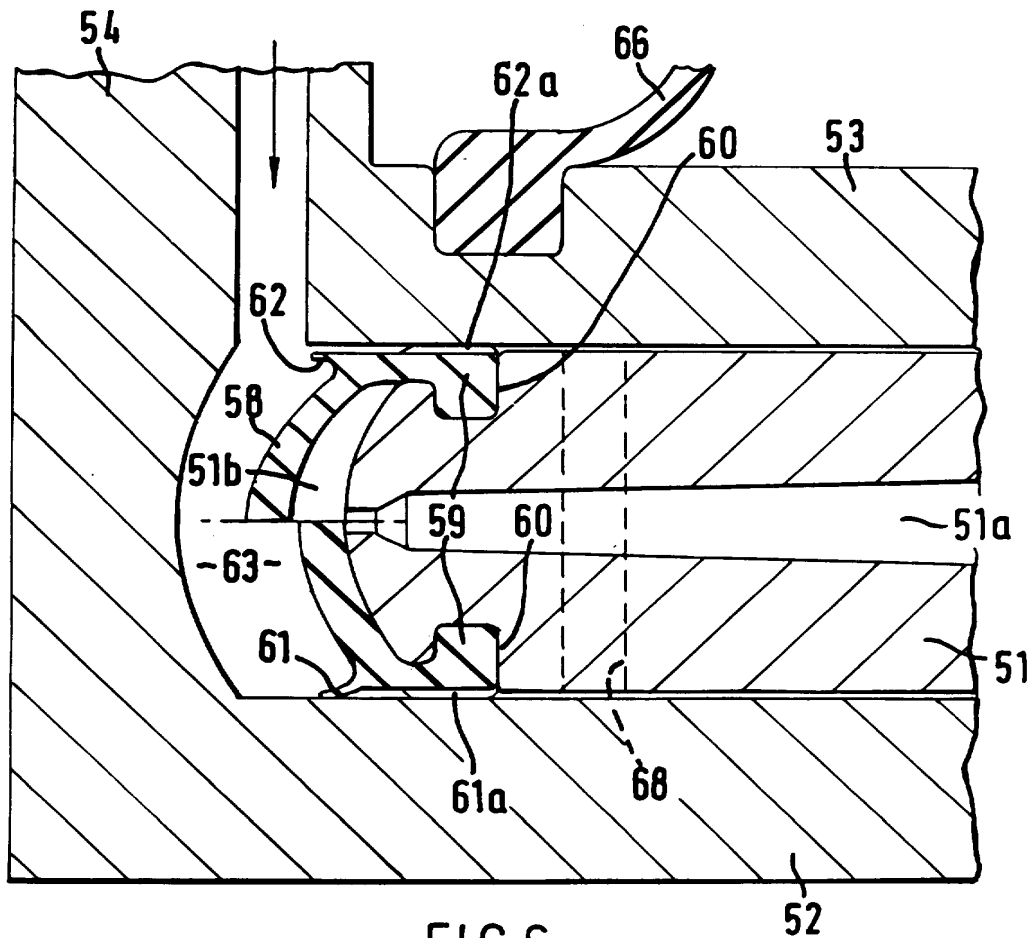
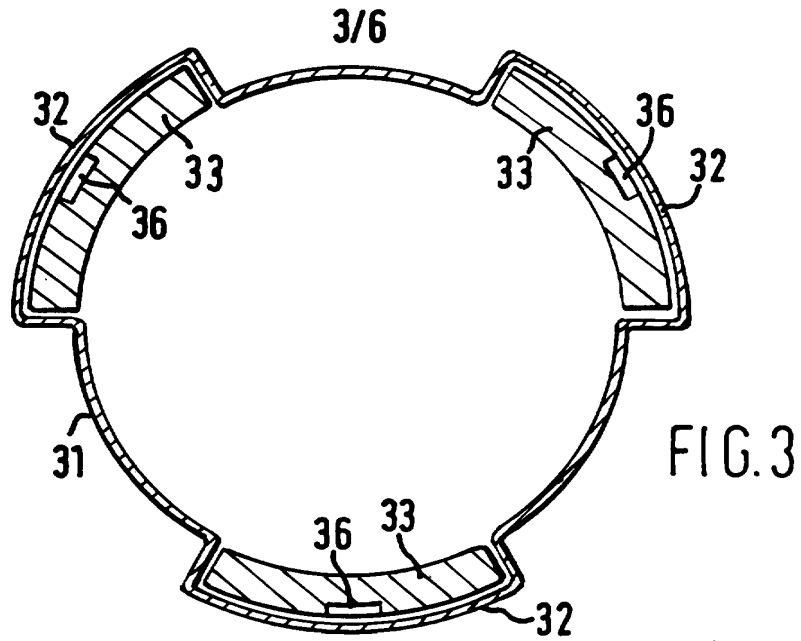


FIG. 6  
SUBSTITUTE SHEET (RULE 26)



5/6

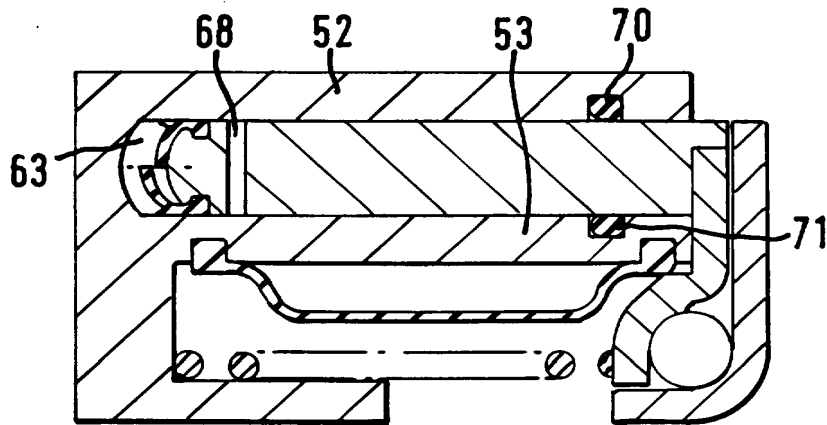
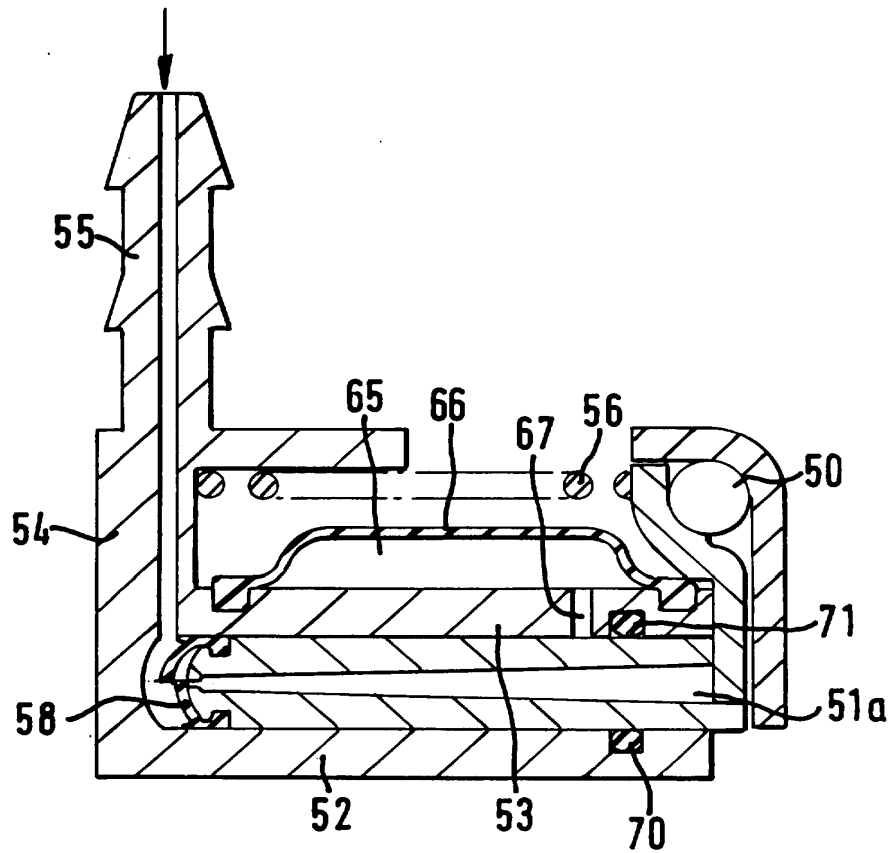
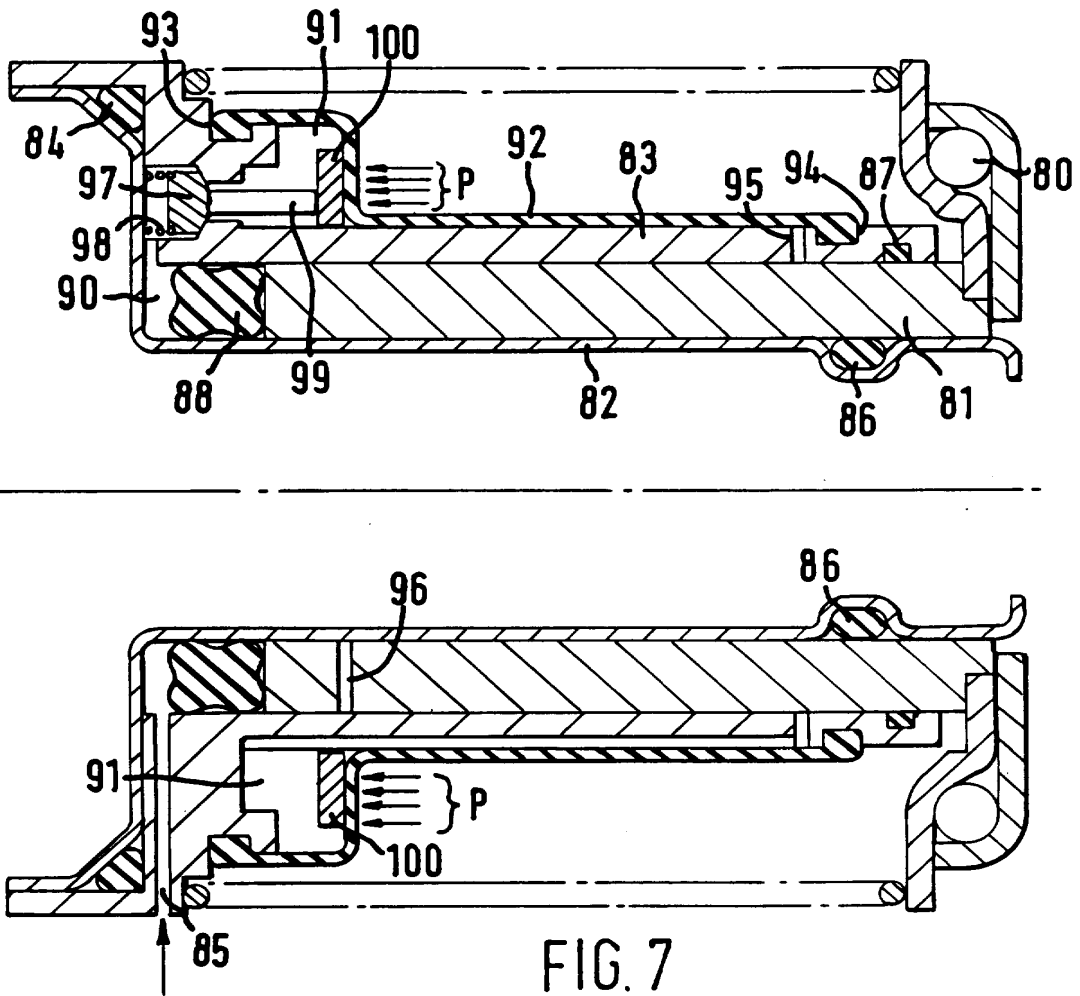


FIG.5


SUBSTITUTE SHEET (RULE 26)



SUBSTITUTE SHEET (RULE 26)

## INTERNATIONAL SEARCH REPORT

International application No.  
PCT/EP 95/05141

<b>A. CLASSIFICATION OF SUBJECT MATTER</b>		
IPC6: F16J 15/56, F15B 15/10, F16D 25/08 According to International Patent Classification (IPC) or to both national classification and IPC		
<b>B. FIELDS SEARCHED</b>		
Minimum documentation searched (classification system followed by classification symbols)		
IPC6: F16J, F15B, F16D		
Documentation searched other than minimum documentation to the extent that such documents are included in the fields searched		
Electronic data base consulted during the international search (name of data base and, where practicable, search terms used)		
<b>C. DOCUMENTS CONSIDERED TO BE RELEVANT</b>		
Category*	Citation of document, with indication, where appropriate, of the relevant passages	Relevant to claim No.
A	US, A, 5113991 (KAJITANI ET AL), 19 May 1992 (19.05.92) --	1-14
A	US, A, 4869355 (CORRAL ET AL), 26 Sept 1989 (26.09.89) --	1-14
A	US, A, 4660702 (FLOTOW), 28 April 1987 (28.04.87) -- -----	1-14
<input type="checkbox"/> Further documents are listed in the continuation of Box C. <input checked="" type="checkbox"/> See patent family annex.		
<ul style="list-style-type: none"> <li>* Special categories of cited documents:</li> <li>"A" document defining the general state of the art which is not considered to be of particular relevance</li> <li>"E" earlier document but published on or after the international filing date</li> <li>"L" document which may throw doubts on priority claim(s) or which is cited to establish the publication date of another citation or other special reason (as specified)</li> <li>"O" document referring to an oral disclosure, use, exhibition or other means</li> <li>"P" document published prior to the international filing date but later than the priority date claimed</li> </ul>		<ul style="list-style-type: none"> <li>"T" later document published after the international filing date or priority date and not in conflict with the application but cited to understand the principle or theory underlying the invention</li> <li>"X" document of particular relevance: the claimed invention cannot be considered novel or cannot be considered to involve an inventive step when the document is taken alone</li> <li>"Y" document of particular relevance: the claimed invention cannot be considered to involve an inventive step when the document is combined with one or more other such documents, such combination being obvious to a person skilled in the art</li> <li>"&amp;" document member of the same patent family</li> </ul>
Date of the actual completion of the international search		Date of mailing of the international search report
11 April 1996		08/05/96
Name and mailing address of the ISA:		Authorized officer
 European Patent Office, P.B. 3818 Patentlaan 2 NL-2280 HV Rijswijk Tel: (+31-70) 340-2040, Tx: 31 651 epo nl Fax: (+31-70) 340-3016		S-E Bergdahl

**INTERNATIONAL SEARCH REPORT**  
Information on patent family members

05/02/96

International application No.  
PCT/EP 95/05141

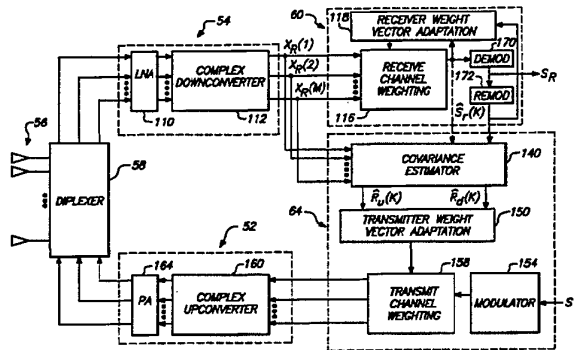
Patent document cited in search report	Publication date	Patent family member(s)	Publication date
US-A- 5113991	19/05/92	WO-A- 8910493	02/11/89
		JP-A- 1234578	19/09/89
		EP-A,B- 0304069	22/02/89
		US-A- 4905016	27/02/90
US-A- 4869355	26/09/89	FR-A,B- 2611838	09/09/88
US-A- 4660702	28/04/87	AU-B,B- 577188	15/09/88
		AU-A- 5572986	30/10/86
		CA-A- 1275676	30/10/90
		DE-A- 3611602	06/11/86
		FR-A- 2581146	31/10/86
		GB-A,B- 2174169	29/10/86
		JP-A- 61248922	06/11/86
SE-A- 8601868	25/10/86		



INTERNATIONAL APPLICATION PUBLISHED UNDER THE PATENT COOPERATION TREATY (PCT)

<p>(51) International Patent Classification <sup>6</sup> : <b>H01Q 25/00, 3/26</b></p>	<p><b>A1</b></p>	<p>(11) International Publication Number: <b>WO 97/00543</b> (43) International Publication Date: 3 January 1997 (03.01.97)</p>
<p>(21) International Application Number: PCT/US96/08564 (22) International Filing Date: 3 June 1996 (03.06.96) (30) Priority Data: 08/491,044 16 June 1995 (16.06.95) US (71) Applicants: WATKINS-JOHNSON COMPANY [US/US]; Stanford Research Park, 3333 Hillview Avenue, Palo Alto, CA 94304-1223 (US). THE BOARD OF TRUSTEES OF THE LELAND STANFORD JUNIOR UNIVERSITY [US/US]; Suite 350, 900 Welch Road, Palo Alto, CA 94304 (US). (72) Inventors: RALEIGH, Gregory, G.; 539 San Juan Avenue, El Granada, CA 94018 (US). DIGGAVI, Suhas, N.; 21F Escondido Village, Stanford, CA 94305 (US). JONES, Vincent, K., IV; 85 Shell Parkway, Redwood Shores, CA 94065 (US). PAULRAJ, Arogyaswami, J.; 59 Peter Coultts Circle, Stanford, CA 94305 (US). (74) Agents: TEST, Aldo, J. et al.; Flehr, Hohbach, Test, Albritton &amp; Herbert, Suite 3400, 4 Embarcadero Center, San Francisco, CA 94111-4187 (US).</p>		<p>(81) Designated States: AL, AM, AT, AU, AZ, BB, BG, BR, BY, CA, CH, CN, CZ, DE, DK, EE, ES, FI, GB, GE, HU, IL, IS, JP, KE, KG, KP, KR, KZ, LK, LR, LS, LT, LU, LV, MD, MG, MK, MN, MW, MX, NO, NZ, PL, PT, RO, RU, SD, SE, SG, SI, SK, TJ, TM, TR, TT, UA, UG, UZ, VN, ARIPO patent (KE, LS, MW, SD, SZ, UG), Eurasian patent (AM, AZ, BY, KG, KZ, MD, RU, TJ, TM), European patent (AT, BE, CH, DE, DK, ES, FI, FR, GB, GR, IE, IT, LU, MC, NL, PT, SE), OAPI patent (BF, BJ, CF, CG, CI, CM, GA, GN, ML, MR, NE, SN, TD, TG).</p> <p><b>Published</b> <i>With international search report.</i></p>

(54) Title: METHOD AND APPARATUS FOR ADAPTIVE TRANSMISSION BEAM FORMING IN A WIRELESS COMMUNICATION SYSTEM



(57) Abstract

A method for forming an adaptive phased array transmission beam pattern at a base station without any knowledge of array geometry or mobile feedback is described. The approach is immune to the problems which plague methods which attempt to identify received angles of arrival from the mobile and map this information to an optimum transmit beam pattern. In addition, this approach does not suffer the capacity penalty and mobile handset complexity increase associated with mobile feedback. Estimates of the receive vector propagation channels are used to estimate transmit vector channel covariance matrices which form objectives and constraints in quadratic optimization problems leading to optimum beam former solutions for the single user case, and multiple user case. The new invention is capable of substantial frequency re-use capacity improvement in a multiple user cellular network.

**FOR THE PURPOSES OF INFORMATION ONLY**

Codes used to identify States party to the PCT on the front pages of pamphlets publishing international applications under the PCT.

AM	Armenia	GB	United Kingdom	MW	Malawi
AT	Austria	GE	Georgia	MX	Mexico
AU	Australia	GN	Guinea	NE	Niger
BB	Barbados	GR	Greece	NL	Netherlands
BE	Belgium	HU	Hungary	NO	Norway
BF	Burkina Faso	IE	Ireland	NZ	New Zealand
BG	Bulgaria	IT	Italy	PL	Poland
BJ	Benin	JP	Japan	PT	Portugal
BR	Brazil	KE	Kenya	RO	Romania
BY	Belarus	KG	Kyrgyzstan	RU	Russian Federation
CA	Canada	KP	Democratic People's Republic of Korea	SD	Sudan
CF	Central African Republic	KR	Republic of Korea	SE	Sweden
CG	Congo	KZ	Kazakhstan	SG	Singapore
CH	Switzerland	LI	Liechtenstein	SI	Slovenia
CI	Côte d'Ivoire	LK	Sri Lanka	SK	Slovakia
CM	Cameroon	LR	Liberia	SN	Senegal
CN	China	LT	Lithuania	SZ	Swaziland
CS	Czechoslovakia	LU	Luxembourg	TD	Chad
CZ	Czech Republic	LV	Latvia	TG	Togo
DE	Germany	MC	Monaco	TJ	Tajikistan
DK	Denmark	MD	Republic of Moldova	TT	Trinidad and Tobago
EE	Estonia	MG	Madagascar	UA	Ukraine
ES	Spain	ML	Mali	UG	Uganda
FI	Finland	MN	Mongolia	US	United States of America
FR	France	MR	Mauritania	UZ	Uzbekistan
GA	Gabon			VN	Viet Nam



METHOD AND APPARATUS FOR ADAPTIVE TRANSMISSION BEAM  
FORMING IN A WIRELESS COMMUNICATION SYSTEM

5 BACKGROUND OF THE INVENTION

This is a continuation in part of U.S. Patent Application Serial No.  
08/394,652, filed February 22, 1995.

I. Field of the Invention

10 The present invention relates to the formation of antenna beam patterns  
(beamforming), and more particularly to a technique for adaptive transmit  
beamforming based on the result of adaptive receive beamforming.

II. Description of the Related Art

15 Within wireless mobile communication systems, directive antennas may be  
employed at base station sites as a means of increasing the signal level received by  
each mobile user relative to the level of received signal interference. This is  
effected by increasing the energy radiated to a desired recipient mobile user, while  
simultaneously reducing the interference energy radiated to other remote mobile  
20 users. Such reduction in the interference energy radiated to mobile users over  
other wireless channels may be achieved through generation of spatially selective,  
directive transmission beam patterns. Unlike "line-of-sight" radio links, a number  
of signal transmission paths typically comprise each wireless communication  
channel.

25 FIG. 1 shows an illustrative representation of a wireless "multipath"  
communication channel between a base station 2 and a remote mobile user 4. The  
various signal transmission paths within each such multipath communication  
channel arise from reflection of the transmitted signal by dominant reflection  
surfaces 6, and by minor reflection surfaces 12, between the base station 2 and  
30 remote mobile user 4. Accordingly, techniques for improving signal reception in  
line-of-sight radio systems are often not directly applicable to multipath signal  
environments. For example, in line-of-sight system the "gain" of an antenna

typically varies inversely to antenna beam width. However, if a given antenna beam width is made less than the angular region encompassing the various signal paths comprising a multipath communication channel, further reduction in the beam width may reduce the energy radiated along some of the angular paths. In turn, this may actually decrease the effective time average gain of the antenna.

Within wireless mobile communication systems, three techniques have been developed for improving communication link performance using directive transmit antennas: (i) selection of a particular fixed beam from an available set of fixed beams, (ii) adaptive beam forming based on receive signal angle estimates, (iii) adaptive transmission based on feedback provided by the remote mobile user, and (iv) adaptive transmit beam forming based upon the instantaneous receive beam pattern. Each of these techniques is described briefly below.

In the first technique, one of several fixed base station antenna beam patterns is selected to provide a fixed beam steered in a particular direction. The fixed antenna beams are often of equal beam width, and are often uniformly offset in boresight angle so as to encompass all desired transmission angles. The antenna beam selected for transmission typically corresponds to the beam pattern through which the largest signal is received. The fixed beam approach offers the advantage of simple implementation, but provides no mechanism for reducing the signal interference power radiated to remote mobile users within the transmission beam of the base station. This arises because of the inability of the traditional fixed beam approach to sense the interference power delivered to undesired users.

The second approach involves "adapting" the beam pattern produced by a base station phase array in response to changing multipath conditions. In such beamforming antenna arrays, or "beamformers", the antenna beam pattern is generated so as to maximize signal energy transmitted to ("transmit beamforming"), and received from ("receive beamforming"), an intended recipient mobile user.

While the process of transmit beamforming to a fixed location over a line-of-sight radio channel may be performed with relative ease, the task of transmitting to a mobile user over a time-varying multipath communication channel is typically considerably more difficult. One adaptive transmit

beamforming approach contemplates determining each angle of departure (AOD) at which energy is to be transmitted from the base station antenna array to a given remote mobile user. Each AOD corresponds to one of the signal paths of the multipath channel, and is determined by estimating each angle of arrival (AOA) at the base station of signal energy from the given user. A transmit beam pattern is then adaptively formed so as to maximize the radiation projected along each desired AOD (i.e, the AOD spectrum), while minimizing the radiation projected at all other angles. Several well known algorithms (e.g., MUSIC, ESPRIT, and WSF) may be used to estimate an AOA spectrum corresponding to a desired AOD spectrum.

Unfortunately, obtaining accurate estimates of the AOA spectrum for communications channels comprised of numerous multipath constituents has proven problematic. Resolving the AOA spectrum for multiple co-channel mobile units is further complicated if the average signal energy received at the base station from any of the mobile units is significantly less than the energy received from other mobile units. This is due to the fact that the components of the base station array response vector contributed by the lower-energy incident signals are comparatively small, thus making it difficult to ascertain the AOA spectrum corresponding to those mobile units. Moreover, near field obstructions proximate base station antenna arrays tend to corrupt the array calibration process, thereby decreasing the accuracy of the estimated AOA spectrum.

In the third technique mentioned above, feedback information is received at the base station from both the desired mobile user, and from mobile users to which it is desired to minimize transmission power. This feedback permits the base station to "learn" the "optimum" transmit beam pattern, i.e., the beam pattern which maximizes transmission to the desired mobile user and minimizes transmission to all other users. One disadvantage of the feedback approach is that the mobile radio needs to be significantly more complex than would otherwise be required. Moreover, the information carrying capacity of each radio channel is reduced as a consequence of the bandwidth allocated for transmission of antenna training signals and mobile user feedback information. The resultant capacity reduction may be significant when the remote mobile users move at a high average

velocity, as is the case in most cellular telephone systems.

The fourth conventional technique for improving communication link performance involves use of an optimum receive beam pattern as the preferred transmission beam pattern. After calibrating for differences between the antenna array and electronics used in the transmitter and receiver, it is assumed that the  
5 instantaneous estimate of the nature of the receive channel is equivalent to that of the transmit channel. Unfortunately, multipath propagation and other transient channel phenomenon can substantially eliminate any significant equivalence between frequency-duplexed transmit and receive channels, or between time-  
10 division duplexed transmit and receive channels separated by a significant time interval. As a consequence, communication link performance fails to be improved.

#### OBJECTS OF THE INVENTION

15 Accordingly, it is an object of the invention to provide an adaptive transmit beamforming technique which enhances remote user received signal quality by utilizing the uplink signal energy received from remote users without the need for feedback from the mobile user.

It is another object of the invention to provide an adaptive transmit  
20 beamforming technique which accounts for the presence of multipath fading inherent in the communication channel.

It is yet another object of the invention that the beamforming technique be independent of antenna array geometry, array calibration, or of explicit feedback control signals from remote users.

25 It is another object of the invention to provide adaptive transmit beam forming which improves signal quality received by a desired user and while simultaneously reducing interference energy received by other undesired users so as to, within a cellular communication network, improve communication traffic capacity, and/or to increase base station coverage area, and/or to improve call  
30 quality.

#### SUMMARY OF THE INVENTION

The adaptive transmission approach of the invention offers the advantages of adaptive transmission using feedback without the associated mobile radio complexity increase and information capacity penalty. The technique has been developed to exploit structured variation which occurs in the multipath fading present in the wireless antenna array channel. Thus, multipath propagation effects are explicitly accounted for in the problem approach. The technique is blind in that the antenna beam is formed in the absence of explicit knowledge of the array geometry, and without the necessity of array calibration or mobile feedback. The basic approach is to estimate the optimum transmit antenna beam pattern based on certain statistical properties of the received antenna array signals. Recently developed results in blind signal copy of multiple co-channel signals using antenna arrays are thus exploited to make possible the estimation of the receive signal statistics. The optimum transmit beam pattern is then found by solving a quadratic optimization subject to quadratic constraints. The adaptive transmission system is suitable for use in conjunction with either a diplexed transmit/receive antenna array, or with separate transmit and receive arrays.

#### BRIEF DESCRIPTION OF THE DRAWINGS

Additional objects and features of the invention will be more readily apparent from the following detailed description and appended claims when taken in conjunction with the drawings, in which:

FIG. 1 is an illustrative representation of a multipath propagation channel between a base station and a remote user station.

FIG. 2A is a block diagram of the physical implementation of a beamforming network configured to perform adaptive beam forming in accordance with the present invention.

FIG. 2B is a block diagram of the physical implementation of a beamforming network in which a diplexor is employed to allow the antenna array to be used for both transmit and receive operation.

FIG. 3 is a functional block diagrammatic representation of a beamforming network of the present invention.

FIG. 4 provides a flowchart summarizing an exemplary procedure for using an optimization function to determine an optimum transmit weight vector.

FIG. 5 is a flowchart outlining a general procedure for determining an optimum transmit weight vector by using transmit criteria in conjunction with  
5 network agreement criteria.

FIG. 6 is a block diagram of an exemplary calibration system incorporated within the adaptive beamforming network of FIG. 3.

FIG. 7 shows an implementation of a calibration system within an adaptive beamforming network having different transmit and receive arrays.

FIG. 8 provides a block diagram of a self-calibrated adaptive beamforming network in which the receive section of the beamforming network is advantageously utilized in lieu of a transmit section calibration receiver.  
10

FIG. 9 is a block diagram of an implementation of a calibration equalizer and channelizer in which a single wideband calibration equalizer is coupled to each  
15 of the outputs of a complex downconverter within an RF receiver.

FIG. 10 depicts a block diagram of an implementation of a transmitter calibration equalizer & channel combiner in which a single transmit wideband calibration equalizer precedes each of the inputs to a complex upconverter.

FIG. 11 is a block diagram of an implementation of a calibration equalizer and channelizer which utilizes a plurality of sets of narrowband calibration equalizers.  
20

FIG. 12 depicts a transmitter calibration equalizer & channel combiner within which the equalization function is performed separately for each channel.

## 25 DETAILED DESCRIPTION OF THE INVENTION

### I. Overview of Beamforming Network

Turning now to FIG. 2A, a block diagram is shown of the physical organization of a beamforming network 50 configured to perform adaptive beam forming in accordance with the present invention. In an exemplary embodiment  
30 the beamforming network 50 is disposed within a base station of a cellular communications network, in which is included a transceiver comprised of a radio frequency (RF) transmitter 52 and an RF receiver 54.

In the embodiment of FIG. 2A, a base station antenna array 56 serves to produce independent transmit and receive antenna beams for facilitating communication with one or more mobile units (not shown). The term "receive channel vector" is employed to indicate that each antenna element within the base station antenna array 56 will form a propagation channel to a given remote user. The composite array channel may be represented as a vector having elements corresponding to each individual antenna channel. As is described herein, statistical characterization of the receive channel vector provides information which may be used by the base station to determine an "optimal" transmit beam pattern, i.e., a transmit beam pattern which maximizes the average signal-to-interference power delivered to a given mobile user. This obviates the need for the mobile unit to provide feedback information to the base station relating to propagation characteristics of the transmit channel. This in turn simplifies implementation of the mobile unit, and preserves channel resources for data transmission by eliminating the need for "mobile unit feedback" relating channel characteristics to the base station.

As is indicated by FIG. 2A, a diplexer 58 can be employed to allow the antenna array 56 to be used for both transmit and receive operation by isolating the RF receiver 54 from the RF transmitter 52. A receive channel beamformer 60 cooperates with the RF receiver 54 to adaptively optimize the receive antenna beam in order to improve received signal quality. Similarly, a transmit channel beamformer 64 cooperates with the RF transmitter 52 to adapt the transmit antenna beam to optimize some characteristic of transmission quality. In an exemplary embodiment the transmit channel beamformer 64 and receive channel beamformer 60 are each implemented as a special purpose digital signal processor (DSP).

In another embodiment of the invention, distinct antenna arrays are used for signal reception and transmission as illustrated in FIG. 2B. In the embodiment of FIG. 2B, a diplexer is not required since a dedicated receive antenna array (not shown) is connected to the RF receiver 54, and a dedicated transmit antenna array (not shown) is connected to the RF transmitter 52. The receive and transmit antenna arrays are designed to provide identical radiation characteristics when operated at the receive and transmit frequencies, respectively. Accordingly, in

many instances the physical geometries of the transmit and receive antenna arrays are simply physically scaled to account for the fractional difference in the receive and transmit RF wavelengths. The embodiment of FIG. 2B substantially eliminates the potential introduction of error arising from use of a single antenna array and diplexer.

Turning now to FIG. 3, a functional block diagrammatic representation is provided of a beamforming network of the present invention. In FIG. 3, solid lines are used to represent functional elements and dashed lines are employed to identify the physical components of FIG. 2. The RF receiver 54 is functionally comprised of a low-noise amplifier (LNA) network 110, and a complex downconverter 112. The complex downconverter 112 is disposed to frequency downconvert the received RF signal energy after processing by the LNA network 110. The downconverted signal energy is then digitally sampled and provided to a receive channel weighting module 116 of the receive channel beamformer 60. The weights applied by the receive channel beamformer 60 to each of the  $M$  downconverted antenna element outputs  $x_{R,m}(k)$ ,  $m = 1$  to  $M$ , of the complex frequency downconverter 112 are determined by a receiver weight vector adaptation module 118. In the exemplary embodiment the receiver weight vector adaptation module 118 determines a receive channel weight vector,  $w_R$ , which maximizes the signal quality received over the desired inbound frequency channel.

In the embodiment of FIG. 3, a vector channel covariance estimator 140 within the transmit beamformer 64 operates to produce a statistical characterization of a receive channel vector using: (i) the outputs  $x_{R,m}(k)$ ,  $m = 1$  to  $M$ , of the complex frequency downconverter 112, and (ii) an estimate of the desired signal  $\hat{S}_r(k)$  generated in the receive channel beamformer 60. For present purposes the receive channel vector may be viewed as being representative of the multipath communications channel from a mobile user (not shown in FIG. 3) to the antenna array 56. In an exemplary embodiment the statistical characterization carried out within the covariance estimator 140 yields an estimated receive channel covariance matrix used during the transmit beamforming process. Throughout the following description, scalar quantities are represented using lower case characters of standard type, vector quantities are represented using lower case characters of bold



type, and matrix quantities are represented using upper case characters of bold type.

Within the transmit channel beamformer 64, an optimal transmit beam pattern weight vector is generated by a transmit channel weight vector adaptation module 150 based on the results of the statistical characterization of the receive channel vector. This weight vector,  $w_T(t)$ , optimizes a particular aspect (e.g., average desired signal to undesired interference ratio) of the signal energy within the transmission range of the base station array 56. In the exemplary embodiment, the optimal transmit beam pattern weight vector is generated using the estimated desired receive channel covariance matrix,  $\hat{R}_d(k)$ , and undesired interference covariance matrix,  $\hat{R}_u(k)$ , both of which are compiled within the covariance estimator 140.

As is indicated by FIG. 3, the signal information ( $S_T$ ) to be transmitted to the desired mobile radio unit is used to modulate a digital baseband carrier within a modulator 154. The modulated signal is then applied to a transmit channel weighting module 158 disposed to weight, on the basis of the optimized transmit pattern weight vector, the input signals corresponding to each element of the antenna array 56. The weighted set of input signals produced by the weighting module 158 are then upconverted in frequency within a complex frequency upconverter 160 of the RF transmitter 52. The resultant frequency-upconverted signals are then amplified by a bank of power amplifiers 164, and provided to the antenna array 56 for transmission via diplexer 58.

In the exemplary embodiment an improved estimate of the received signal is obtained through utilization of a demodulator 170 and remodulator 172. The received signal is demodulated within demodulator 170 in order to recover the essential characteristics of the modulating signal. In the case of an analog FM signal, this involves recovery of the FM waveform. In the case of a digitally modulated signal (BPSK, FSK, QPSK, etc.), the demodulator 170 forms hard decisions as to the value of each digital symbol. The demodulated signal is then processed based upon some predefined characteristic of the signal and modulation pattern. For example, a demodulated analog FM signal could be lowpass filtered

based upon a known signal information bandwidth as a means of obtaining an improved post-demodulation signal estimate. In the case of digital modulation, error correction could be implemented in order to remove bit errors, thus improving estimated signal quality. In addition, training signals (i.e., pilot tones, SAT tones, etc.) may optionally be employed in lieu of, or in conjunction with, the aforementioned "blind" techniques.

Again referring to FIG. 3, the processed demodulated signal is then used by demodulator 172 to remodulate an RF carrier, thereby producing an improved modulated signal estimate. The improved signal estimate is then used by the receiver weight vector adaptation block 118 and the covariance estimate 140. Other techniques, which do not rely upon such a demodulation/remodulation procedure, can be devised for obtaining a sufficiently accurate received signal estimate. FIG. 3 simply illustrates a particular exemplary embodiment incorporating a demodulator and remodulator.

In the present embodiment, the demodulator 170 and remodulator 172 or the receive channel beamformer 60 are operative to produce a received signal estimate  $\hat{s}_r$ . The quantity  $\hat{S}_r$  is then employed by the covariance estimator 140 to estimate the covariance matrix of the receive channel. The receive channel beamformer 60 could of course be replaced by numerous alternative structures including, for example, multi-antenna sequence estimators, maximum likelihood receiver structures, or multiple element decision feedback equalizers. Any of these alternative structures could also be used to provide the quantity  $\hat{s}_r$  for use in estimating the received channel covariance statistics.

A detailed description of the adaptive transmit beamforming contemplated by the invention is provided in the following sections. Specifically, section II sets forth a description of transmit and receive multipath antenna channel models, as well as an introduction to the approach of utilizing receive channel statistics during transmission channel beamforming. Section III discusses the extension of the single-user beamforming approach of section II to an environment which includes multiple mobile users.

In section IV, an exemplary method is described for estimating receive channel statistics useful for effecting the transmit channel beam forming of the

present invention. Finally, section V provides a description of various techniques for calibrating the transmit and receive channel beamforming apparatus.

## II. Blind Beamforming Using Multipath Signals

5 As mentioned above, an initial step within the present invention involves statistically characterizing a receive channel vector representative of the multipath communications channel from a mobile user to a base station antenna array 56. In order to facilitate understanding of this process, a mathematical description will first be provided of an exemplary receive channel vector corresponding to a  
10 multi-element antenna array. It will then be shown that a high degree of similarity exists between a covariance characterization of the receive channel vector, and a covariance characterization of the transmit channel vector. The present invention makes use of the similarity between the receive and transmit channel covariance characterizations, notwithstanding the typical lack of correlation between the  
15 instantaneous transmit and receive channel vectors. As will also be described, the similarity between receive and transmit covariance makes it possible to determine an advantageous transmit beam pattern in the absence of explicit knowledge of the antenna array configuration. In this sense, the optimal beamforming of the present invention may be considered to be "blind" with respect to antenna array  
20 configuration.

The optimal transmit beamforming technique of the present invention is of particular utility in multipath propagation environments, in which mountains, buildings and the like create multipath interference (FIG. 1). In FIG. 1, energy radiated from the antenna array at each base station 2 is reflected by the dominant  
25 reflectors 6. Many local reflectors 12 nearby the mobile unit 4 also contribute to energy reflection. As the position of the mobile unit 4 varies, the phase length to each dominant reflector 6 and to each local 12 reflector correspondingly varies, which results in a time-variant vector propagation channel from the base station 2 to the mobile unit 4.

30 A vector channel model for the energy  $y_R(t)$  received by a mobile unit from the base station may be expressed as:

$$\begin{aligned}
 y_R(t) &= s_T(t) \mathbf{w}_T(t)^H \left[ \sum_{l=1}^L \alpha_{T,l}(t) \mathbf{a}_T(\theta_l) \right] + n_T(t) \\
 &= s_T(t) \mathbf{w}_T(t)^H \mathbf{h}_T(t) + n_T(t)
 \end{aligned}
 \tag{1}$$

where  $s_T(t)$  denotes the complex-valued signal transmitted to the mobile unit, where  $\mathbf{n}_T(t)$  represents the complex-valued  $M$ -element noise vector received at the mobile unit, where  $\mathbf{w}_T(t)^H$  corresponds to the Hermetian transpose of the  $M$ -element complex-valued weight vector  $\mathbf{w}_T(t)$  representative of the  $M$ -element base station transmit antenna array 56, and where  $\mathbf{h}_T(t)$  represents the  $M$ -element time varying transmit channel array response vector. In addition, the time-varying amplitude loss for the  $l^{\text{th}}$  of  $L$  signal propagation paths between the base station transit antenna array 56 and the mobile unit is given by  $\alpha_{Tl}(t)$ . Finally,  $\mathbf{a}_T(\theta_l)$  corresponds to the transmit array response vector due to the propagation path along the  $l^{\text{th}}$  path of departure  $\Theta_l$ . Each element within  $\mathbf{a}_T(\theta_l)$  represents the complex magnitude of the field radiated in the direction  $\Theta_l$  by an antenna element when a unit amplitude radiation signal is applied to the antenna element. Although for purposes of clarity, the base station transit antenna array 56 is assumed to be comprised of  $M$  omnidirectional elements and the mobile unit equipped with a single omnidirectional antenna, the following analysis may be readily extended to embodiments in which directional antenna elements are employed.

In a particular single-user implementation of the invention, a primary objective is to generate a base station transmit beam pattern which maximizes the signal relative to the noise within the received mobile signal  $y_R(t)$ . Since in the single-user case one is not concerned with minimizing interference to mobile units within other cells operative on the same frequency channel, this objective may be attained by simply maximizing the signal received at the single mobile unit. The single user case approximates conditions in cellular networks characterized by large geographic separation between base stations utilizing the same frequency channels. Ideally, the value of the transmit channel array response vector  $\mathbf{h}_T(t)$  would be determined on an instantaneous basis, which could easily be shown to allow determination of the transmit beam weight vector  $\mathbf{w}_T(t)$  resulting in the reception of the maximum possible signal power at the mobile unit.

Unfortunately, it is not generally possible to instantaneously determine an accurate transmit channel array response vector  $\mathbf{h}_T(t)$  by instantaneously characterizing the receive channel from the mobile unit. This is a consequence of the frequency duplexed operation typical of most cellular systems, in which each  
 5 frequency-duplexed communication channel is assigned different uplink and downlink frequencies. The difference in transmit and receive frequencies results in minimal correlation existing between the instantaneous transmit and receive channel array response vectors. This tends to preclude determination of an  
 10 optimal transmit beam weighting vector  $\mathbf{w}_T(t)$  using instantaneous values of the receive channel array response vector.

In contrast, it has been found that there exists significant correlation between time-averaged covariance behavior of frequency-duplexed transmit and receive channel pairs. Since what follows will pertain to time-averaged channel covariance behavior, a time-independent transmit beam weight vector notation  $\mathbf{w}_T$   
 15 will be used in lieu of a time-dependent transmit beam weight vector  $\mathbf{w}_T(t)$ . This does not imply that the weight vector  $\mathbf{w}_T$  will be completely time-independent, but rather that the weight vector  $\mathbf{w}_T$  will not vary significantly over the time periods within which are accumulated the channel statistics required for the covariance characterization of the channel described hereinafter.

20 An optimum average power transmit weight vector,  $\hat{\mathbf{w}}_T$ , will now be defined as that beam pattern vector which maximizes the average signal power received by a given mobile unit, wherein  $\hat{\mathbf{w}}_T$  is expressed as follows:

$$\begin{aligned} \hat{\mathbf{w}}_T &= \arg \left[ \max_{\mathbf{w}_T} \left[ E(\mathbf{w}_T^H \mathbf{h}_T(t) s_T^*(t) s_T(t) \mathbf{h}_T(t)^H \mathbf{w}_T) \right] \right] \\ &= \arg \left[ \max_{\mathbf{w}_T} \left[ \mathbf{w}_T^H \mathbf{R}_{h_T} \mathbf{w}_T \right] \right] \end{aligned} \quad (2)$$

where  $\mathbf{R}_{h_T}$  denotes the transmit vector channel covariance matrix evaluated at zero  
 25 time shift and  $E(\cdot)$  denotes the statistical expectation operator. It may be assumed within equation (2) that the total power radiated by the base station antenna array

is less than or equal to some predefined maximum base station power  $P_{Tmax}$ , or, equivalently, that  $w_T^H w_T \leq P_{Tmax}$ . One solution to equation (2) is obtained by setting the optimum weight vector  $\hat{w}_T$  equal to the principal unit-norm eigenvector for  $R_{b,T}$  scaled by  $\sqrt{P_{Tmax}}$ .

5            If the transmit vector channel covariance matrix  $R_{b,T}$  could be derived by the covariance estimator 140 in the absence of feedback from the mobile unit, the foregoing makes clear that the optimum transmit weight vector  $\hat{w}_T$  could be straightforwardly determined. However, since the transmit channel information is generally unavailable to the base station, an estimation of the receive channel  
10 array response vector is manipulated within the covariance estimator 140 in order to closely approximate the transmit vector channel covariance matrix  $R_{b,T}$ . Once  $R_{b,T}$  has been approximated, the transmit weight vector  $\hat{w}_T$  is easily obtained within the transmitter weight vector adaptation module 150 in the manner described above.

15            In an alternate embodiment, the optimum transmit beam pattern weight vector is selected from a finite set of pre-determined weight vectors,  $\{W_T\}$  giving rise to a corresponding set of predefined transmit beam patterns. In this case the beam pattern may be formed by, for example, selectively assigning fixed  
20 RF phased array elements. Rather than finding a closed form eigenvector solution to equation (2), in this embodiment a discrete search is performed for the one of the predefined transmit beam pattern weight vectors having the highest inner product with the desired covariance matrix  $R_{b,T}$  per equation (2).

25            Various differences will now be examined between the frequency-duplexed transmit and receive channels over which communication occurs between a base station and a mobile unit. In a single-user environment, the vector  $x_R(t)$  is representative of the set of output signals produced by the base station antenna array 56 in response to a signal  $s_R(t)$  received from the mobile unit, and is given by:

30

where  $n_R(t)$  is an M-element noise vector representative of the noise added by the base station receiver. In a multipath signal propagation environment, it has been

$$\begin{aligned} \mathbf{x}_R(t) &= \sum_{l=1}^L \mathbf{a}_R(\theta_l) \alpha_{R_l}(t) s_R(t) + \mathbf{n}_R(t) \\ &= \mathbf{h}_R(t) s_R(t) + \mathbf{n}_R(t) \end{aligned} \quad (3)$$

generally found that little correlation exists between: (i) the instantaneous amplitude  $\alpha_{R,l}(t)$  along each angle of arrival  $\theta_l$ , and (ii) the instantaneous propagation path amplitude  $\alpha_{T,l}(t)$  along each angle of departure  $\theta_l$  for the transmit channel. Accordingly, it is expected that attempting to map the instantaneous receive channel array response vector  $\mathbf{h}_R(t)$  to an instantaneous transmit channel weight vector  $\mathbf{w}_T(t)$ , will generally not maximize the power delivered to the mobile unit.

While there is often little correlation between the instantaneous values of the transmit and receive vector channels, it has been found that if the transmit and receive antenna arrays are properly configured, there exists a high degree of similarity between  $\mathbf{R}_{h,T}$  and  $\mathbf{R}_{h,R}$ . As a consequence, the covariance estimator is designed to estimate an optimum transmit channel covariance matrix  $\mathbf{R}_{h,T}$  from a time-averaged receive channel covariance matrix  $\mathbf{R}_{h,R}$ . It has been found that under the conditions described below, the substitution of the receive channel covariance matrix  $\mathbf{R}_{h,R}$  within equation (2) yields a value for  $\hat{\mathbf{w}}_T$  resulting in the base station delivering nearly as much power to the mobile user as would have been delivered had  $\mathbf{R}_{h,T}$  been used to derive  $\hat{\mathbf{w}}_T$ .

From equations (1) and (2), the transmit channel covariance matrix may be expressed as:

$$\begin{aligned} \mathbf{R}_{h,T} &= E \left\{ \left[ \sum_{l=1}^L \mathbf{a}_T(\theta_l) \alpha_{T,l}(t) \right] \left[ \sum_{k=1}^L \mathbf{a}_T(\theta_k) \alpha_{T,k}(t) \right]^H \right\} \\ &= \sum_{l=1}^L E \{ |\alpha_{T,l}(t)|^2 \} \mathbf{a}_T(\theta_l) \mathbf{a}_T(\theta_l)^H \end{aligned} \quad (4)$$

20

where  $E(*)$  denotes the probabilistic expectation operation, and where it has been assumed that each angle of departure path fades independently, i.e.,

$$E(\alpha_{T,i}(t)\alpha_{T,k}^*(t))=0 \text{ for } i \neq k. \quad (5)$$

Similarly, the receive covariance matrix may be expressed as

$$\mathbf{R}_{h,R} = \sum_{l=1}^L E\{|\alpha_{R,l}(t)|^2\} \mathbf{a}_R(\theta_l) \mathbf{a}_R(\theta_l)^H \quad (6)$$

Equations (4) and (6) have been formulated under the assumption that an equal number of dominant reflectors, at identical locations, exist at the transmit and receive channel frequencies. This constraint will typically be met, since the existence of dominant reflectors of large size increases the likelihood of substantially similar reflection at the slightly different transmit and receive frequencies of each duplex communication channel.

As may be appreciated by comparing equations (4) and (6), the assumed equivalence of the transmit and receive channel covariance matrices is justified if (i) the average strengths  $E\{|\alpha_i(t)|^2\}$  of the transmit and receive paths are equal, and if (ii) the receive and transmit array response vectors  $\mathbf{a}_R(\theta_l)$  and  $\mathbf{a}_T(\theta_l)$  are substantially the same. For the typical case of a small frequency offset between transmit and receive channels, it has been found that condition (i) is generally met. That is, the transmit and receive channel average path strength is invariant with respect to transmit and receive frequency translation. Condition (ii) may be satisfied if the antenna array(s) used for transmission and reception are substantially insensitive to the frequency difference between the transmit and receive channel bands. In the case of a single antenna array disposed for transmit and receive operation via a diplexer, the requisite frequency insensitivity may be achieved through use of antenna having elements exhibiting substantially the same amplitude and phase response over both the transmit and receive channel bands. Alternately, the frequency difference between the transmit and receive channel bands may be compensated for by appropriately scaling the dimensions of, and spacing between, the antenna elements within separate transmit and receive antenna arrays.

The foregoing makes clear that transmit channel weight vector may be



determined by the transmitter weight vector adaptation module 150 on the basis of a second order statistical characterization of the received array response vector. It is nonetheless to be understood that the compilation of other statistical characterizations of the receive array response vector as a means of determining an optimum transmit beam weight vector is also within the scope of the present invention.

### III. Beamforming in Multiple User Environment

In the preceding section it was shown that, within a single user environment, a close approximation of an optimum transmit beam pattern could be effected using the receive array response vector covariance matrix. In the exemplary single user case discussed above, an optimum transmit beam pattern is obtained by simply attempting to maximize power delivered to the mobile user's receiver by the base station antenna array. In this section, a technique is described in which signal power delivered to an intended recipient mobile user by a base station array is maximized, while for other mobile users the base station array simultaneously minimizes the delivered interference power. In what follows the term "interference power" refers to signal energy transmitted by a base station array which is intended for reception by a particular mobile user, but which is also received by one or more other unintended mobile users.

It is noted that the exemplary embodiment described herein illustrates a scheme for forming an adaptive transmission beam for the purpose of reducing cellular frequency re-use intervals, thereby increasing network call traffic capacity. However, it is understood that the signal to interference maximization criteria described below may be equally applied in other contexts. For example, in an alternate embodiment these criteria may enable sharing of frequency channels by more than a single mobile user within a given cell as a means of increasing network call traffic capacity.

In conventional cellular systems of the type which allocate each channel frequency within a cell to a single mobile user, the cells are dimensioned such that base stations using the same frequency set are sufficiently separated to ensure that mutual "co-channel" (i.e., same frequency) interference is kept below an

acceptable level. Unfortunately, this technique for partitioning frequencies among adjacent cells tends not only to reduce traffic capacity per base station, but also reduces trunking efficiency.

It is known that the ratio of the radius of an individual cell ( $R$ ) to the distance between the centers of co-channel cells ( $D$ ) determines amount of co-channel interference that a mobile user can expect to experience. It is also known that this ratio ( $D/R$ ) determines the number of distinct channel sets that are assigned to cells throughout the cellular system. Increasing the value of  $D/R$  causes the mobile unit receive less interfering signal power (on average) and requires the cellular system to use a greater number of channel sets (i.e., a larger frequency re-use factor). Since the total number of frequency channels is fixed, increasing the number of channel sets reduces the number of frequency channels available to each cell and results in a reduction in cell capacity. A further capacity penalty arises from considerations of trunking efficiency, which become increasingly significant as the number of channels available to a given cell are reduced.

Accordingly, a trade-off typically exists between the average amount of interference received by a mobile unit within a cellular network, and the number of calls capable of being supported at any given time by each cell in the system. Since the present invention improves the average signal to interference ratio experienced by a mobile user's receiver by the use of adaptive transmit beamforming, the value of  $D/R$  for the system may be reduced until the mobile unit's interference threshold is once again reached. This advantageously results in an increase in system capacity due to the reduced  $D/R$  ratio. If instead the mobile unit's  $D/R$  is not reduced, the mobile unit will instead experience a higher quality connection.

It is further apparent that the present invention may also be employed to increase base station coverage area and/or improve some measure of call quality in lieu of, or in addition to, improving network capacity.

In the exemplary embodiment, an adaptive antenna array is employed at each base station as a means of reducing the interference delivered to undesired users within adjacent cells while simultaneously maximizing the average power to

the desired user. In this way the frequency "re-use" interval of the cellular network is improved by reducing the number of cells needed to be interposed between base stations using the same frequency set. The interference power delivered by the base station array within a given cell to co-channel mobile users in adjacent cells is determined within the covariance estimator 140 by forming an "undesired" covariance matrix for each such user by statistically characterizing (as described in section I) the signal energy received therefrom. This allows formulation of an expression for an optimum transmit beam weight vector matrix  $W_{T,OPT}$  as a function of:

- 10 (i) the desired covariance matrix characterizing the communications channel between each base station in the network and the "desired" mobile user serviced by each such base station utilizing the same frequency channel, and
- (ii) the undesired covariance matrices associated with each base station, wherein each undesired covariance matrix characterizes the signal propagation
- 15 between a base station and one co-channel mobile user in an adjacent cell.

An exemplary expression for the matrix of optimum transmit beam weight vectors ( $W_{T,OPT}$ ) is set forth below:

$$W_{T,opt} = \arg \left\{ \max_{W_T} \left[ \min_i \left( \frac{w_{T_i}^H R_{kTd_i} w_{T_i}}{d + \sum_{\substack{j=1 \\ j \neq i}} w_{T_j}^H R_{kTj} w_{T_j}} \right) \right] \right\} \quad (7)$$

subject to the constraints of

$$\frac{w_{T_i}^H R_{kTd_i} w_{T_i}}{d + \sum_{\substack{j=1 \\ j \neq i}} w_{T_j}^H R_{kTj} w_{T_j}} \geq SNR_{min}$$

20

where

$w_T = [w_{T1} \ w_{T2} \ . \ . \ . \ w_{Td}]$  is the optimal transmit beam weight vector matrix, in which  $w_{Td}$  corresponds to the optimum transmit weight beam vector of the  $d$ th base station antenna array;

$R_{bTd_i}$  is the desired transmit covariance matrix for user  $i$ ;

5  $R_{bTd_{i,j}}$  is the undesired transmit covariance matrix  $j$  for user  $i$ ; and

$SNR_{min}$  is the minimum allowable SNR for each mobile user.

The optimization expression of equation (7) is formulated in order to maximize the minimum signal to interference ratio ( $SNR_{min}$ ) experienced by any given desired mobile user within the network. That is, it is intended that each  
10 desired mobile user receives sufficient signal energy to ensure that a minimum signal to interference plus noise ratio ( $SINR_{min}$ ) required for acceptable communications quality is established for each mobile user. When it becomes infeasible for every desired user to experience a SINR greater than  $SINR_{min}$ , it is expected that the user experiencing the lowest SINR will be assigned to another  
15 frequency channel. The optimization contemplated by equation (7) is then performed again with fewer co-channel users.

In embodiments in which means are not provided for communication between the base stations of different cells, the exact interference power transmitted to each desired user by all adjacent cell base stations is unknown to a  
20 given base station. However, a given base station is capable of estimating the covariance matrices characterizing signal propagation from the base station to its desired user and the undesired users in adjacent cells. Accordingly, equation (7) may be reformulated as a maximization of the power delivered by each base station to the desired mobile user within its cell, subject to constraints on the  
25 amount of interference power which may be delivered to any one of the undesired co-channel users in adjacent cells. By setting an upper limit on the amount of interference power which any given base station is permitted to deliver to an undesired co-channel user in an adjacent cell, and a lower limit on the minimum power received by the desired user, each mobile user is guaranteed to experience  
30 an average signal to noise ratio in excess of  $SINR_{min}$  in the event that a solution to the optimization problem is found.

This reformulated optimization may be expressed as:

$$w_T = \arg \left\{ \max_{w_T} (w_T^H R_{kTd} w_T) \right\} \quad (8)$$

subject to the constraints of,

$$\begin{aligned} w_T^H R_{kTd} w_T &\geq P_{Rmin} \\ w_T^H R_{kTj} w_T &\geq P_{Imax} \quad \forall j \\ P_{Tmin} &\leq w_T^H w_T \leq P_{Tmax} \end{aligned}$$

wherein,

5  $R_{kTd}$  is the covariance matrix characterizing the communication channel between the desired user and base station within a given cell,

$R_{kTj}$  is the interference covariance matrix from a given cell to the  $j^{\text{th}}$  co-channel user within an adjacent cell,

10  $P_{Imax}$  is the maximum interference power allowed to be delivered by any given base station to any undesired co-channel users within adjacent cells,

$P_{Rmin}$  is the minimum signal power to be received by a desired user in order to ensure that each desired user experience a signal to interference ratio in excess of  $SNR_{min}$ ,

15  $P_{Tmax}$  is the maximum power capable of being transmitted by a base station, and wherein

$P_{Tmin}$  is the minimum power which must be transmitted given a limited capability by the mobile receiver to reject signal power at adjacent channel frequencies.

20 Although capable of providing an desirable transmit beam weight vector for use at each base station, the optimization function of equation (8) is relatively computationally intensive in that a covariance matrix is required to be compiled for each undesired co-channel user. In what follows, the computational complexity of the optimization function of equation (8) is reduced by obviating the need for knowledge of the covariance matrix associated with each undesired  
25 co-channel user. This is accomplished by formulating an optimization expression

dependent upon the summation of all undesired interference covariance matrices, rather than upon the individual undesired interference covariance matrices. The process of optimizing with respect to the summation of all interference power affords various advantages. For example, the necessary channel covariance estimates can be obtained using only the received signal vector and various ways an estimate of the desired mobile uplink signal. In contrast, individual undesired covariance matrices can generally only be determined if estimates of the undesired interfering signals are generated.

Assuming the various mobile uplink signals to be uncorrelated, the base station received signal vector covariance may be written as

$$R_x = E\{x_R(t)x_R(t)^H\} = P_{s_d} R_{hR_d} + \sum_{i=1}^{N_{int}} P_{s_i} R_{hR_{u_i}} + R_n \quad (9)$$

which allows the approximation,

$$\sum_{i=1}^{N_{int}} P_{s_i} R_{hR_{u_i}} = R_x - P_{s_d} R_{hR_d} - R_n \approx \hat{R}_x - P_{s_d} \hat{R}_{hR_d} \quad (10)$$

where  $\hat{R}_x$  and  $R_{hR_d}$  are estimated covariance matrices corresponding to the raw received signal vector,  $x_R(t)$ , and the desired user channel vector channel and  $P_{s_i}$  is the power transmitted by the  $i^{TH}$  mobile user. The approximation in equation (10) allows formulation of an optimization function which depends upon the summation of the interference covariance matrices associated with a set of undesired co-channel users, rather than a function dependent upon derivation of a separate interference covariance matrix for each undesired co-channel user. More particularly, the simplified optimization function may be expressed as:

$$w_{T,OPT} = \text{arg} \left\{ \max_{w_T} (w_T^H R_{HTd} w_T) \right\} \quad (11)$$

subject to the constraints of

$$w_T^H \left[ \left\{ \sum_{i=1}^{N_{int}} R_{kT u_i} \right\} + I_M \frac{P_{I_{max}}}{P_{T_{max}}} \right] w_T \leq P_{I_{max}}$$

where  $P_{I,max}$  is the maximum allowable total delivered interference power,  $P_{T,max}$  is the maximum allowable transmission power, and where  $I_M$  is an  $M \times M$  identity matrix. In addition, this simplified optimization function is subject to the

5 feasibility checks of:

$$\begin{aligned} w_T^H w_T &\geq P_{Tmin} \\ w_T^H R_{kTd} w_T &\geq P_{Rmin} \end{aligned}$$

One solution to equation (11) is the scaled, generalized eigenvector associated with  
 10 the largest generalized eigenvalue of the following matrix pair:

$$\left( R_{kTd}, \left[ \left\{ \sum_{i=1}^{N_{int}} R_{kT u_i} \right\} + I_M \frac{P_{I_{max}}}{P_{T_{max}}} \right] \right).$$

In an alternate embodiment, the optimum transmit beam pattern weight vector  $\{W_T\}$  is selected from a finite set of pre-determined weight vectors giving rise to a corresponding set of predefined transmit beam patterns. In this case the  
 15 beam pattern may be formed by, for example, selectively assigning fixed amplitude and phase weights to each antenna element via a network of switched RF phased array elements. Rather than finding a closed form eigenvector solution to equation (2), in this embodiment a discrete search is performed for the one of the predefined transmit beam pattern weight vectors providing the most  
 20 advantageous solution to the optimization problem posed by equation (7), (8) or (11). In a specific implementation, the most advantageous solution is provided by the one of the predetermined transmit beam pattern weight vectors giving rise to

the highest signal to interference ratio.

It is recognized that the random process associated with each vector channel is not strictly stationary. Therefore, the covariance matrix description of the channel can not be considered as time invariant. However, the process components causing variation in the time-averaged covariance estimates tend to vary more slowly than so-called fast fading components of the random channel process. These slowly changing process components include log normal shadowing, base station path propagation angles, and local scatterer propagation angles. While the preceding discussion expresses the covariance channel descriptions as time invariant, it is recognized that the covariance estimate must be viewed as an approximation for time average channel behavior over some finite length time window. Accordingly, an exemplary manner is described below for adapting the channel covariance estimates to the time variation in the slowly changing channel process components. Although many adaptive techniques could be used, one choice involves application of a first order IIR filter to successive estimates of the channel covariance. This may be expressed mathematically as

$$\hat{\mathbf{R}}(k) = \lambda \hat{\mathbf{R}}(k-1) + \mu \hat{\mathbf{R}}_{\text{NEW}}(k) \quad (12)$$

Where  $\mathbf{R}(k)$  is the covariance estimate at time index  $k$ ,  $\mathbf{R}_{\text{NEW}}(k)$  is the covariance estimate associated with the channel data gathered between time index  $k-1$  and  $k$ , and  $\lambda$  and  $\mu$  are chosen to provide the desired IIR filter response.

FIGS. 4 and 5 provide flowcharts representative of various methods for adaptively determining a transmit weight vector in accordance with the invention. In what follows the term "desired mobile unit" refers to the mobile unit in communication over a given frequency channel with the base station within which is disposed the beamforming network 50. Likewise, the term "undesired mobile unit" refers to a mobile within a different cell engaged in communication, on the given frequency channel, with the base station of the different cell.

Referring now to FIG. 4, there is provided a flowchart summarizing an exemplary procedure for using an optimization function such as equation (11) to determine the transmit weight vector. As an initial step, the beamforming network 50 (FIG. 2) is calibrated in accordance with one of the techniques described below



in Section V. Next, the covariance estimator 140 (FIG. 3) determines an estimated receive channel covariance matrix as described above in Section II.

The transmitter weight vector adaptation module 150 then computes a transmit weight vector using the estimated receive channel covariance matrix.

5 This computation is done in accordance with predefined network agreement criteria inherent within the optimization function evaluated within the weight vector adaptation module 150. In the exemplary case of the optimization function of equation (11), the pertinent transmit criteria is defined as maximization of the ratio of (i) the average power delivered to the desired mobile unit on a given  
10 frequency, to (ii) the average total interference delivered to undesired mobile units on the given frequency. If the feasibility checks associated with equation (11) are satisfied for transmission on the given frequency, then the given frequency is deemed satisfactory for communication with the desired mobile unit. If these feasibility checks are not satisfied, a different frequency is evaluated.

15 In an alternate embodiment, the relevant transmit criteria used in the procedure of FIG. 4 may simply mandate the maximization of the average signal power delivered to the desired mobile unit. This obviates the need for determination of an average receive channel covariance matrix representative of the communication channel to undesired users, and reduces computational  
20 complexity. This transmit criteria is believed to be particularly suitable for use in CDMA or frequency-hopped TDMA systems, in which undesired user interference statistics are either unavailable or uninformative.

In the general case, each base station in the cellular network could be constrained to limit transmission to undesired users on the basis of common  
25 "network agreement criteria". In an exemplary embodiment such network agreement criteria could comprise placing the following types of constraints upon the power transmitted by each base station:

- 1) an upper bound on the total power transmitted on a given channel to desired and undesired users,
- 30 2) a lower bound on the power received by the desired user,
- 3) a fixed upper bound on the interference power transmitted to any or all undesired users,

4) an adaptive bound on power transmitted to desired/undesired users dependent upon current traffic channel demand (thereby allowing a compromise to be made between network call capacity and call quality).

- 5                   5) a lower bound on the total transmitted power
- 6) any other lower bound on acceptable signal or call quality to the desired user (i.e., average probability of bit error, etc.)

FIG. 5 is a flowchart outlining a general procedure for determining a transmit weight vector by using: (i) transmit criteria in the above-described manner (FIG. 4) to define the objective of an optimization function, and (ii) network agreement criteria to ensure that any optimum weight vector produced in (i) results in transmission satisfying predefined constraints. Again, the first step in the procedure of FIG. 5 involves calibration of the beamforming network 50 (FIG. 2) in accordance with one of the techniques described below in Section V. Next, the covariance estimator 140 (FIG. 3) determines an estimated receive channel covariance matrix as described above in Section II.

The transmitter weight vector adaptation module 150 then computes an optimum transmit weight vector using the estimated receive channel covariance matrix. This computation is done in accordance with predefined network agreement criteria inherent within the optimization function evaluated within the weight vector adaptation module 150. The transmit weight vector solution is then evaluated in light of network agreement criteria of the type listed above to ascertain whether the resultant desired and/or undesired user transmission quality is appropriately bounded. If so, a new estimate is made of the receive channel covariance matrix (which in general will have changed due to movement of desired/undesired mobile units), and the above process is repeated. If the network agreement criteria are not satisfied, a new frequency is selected for at least one of the users and the above process is similarly repeated. If no new frequencies are available, either a call handoff request is sent to the MTSO, or appropriate indication is provided to the calling party. That is, the calling party is informed that communication is incapable of currently being established or maintained with the desired mobile unit, and the call is dropped.

In the general case, the evaluation of transmitted signal power in view of the network agreement criteria will be regularly repeated after communication has been established with the desired mobile unit. When the transmitted signal power begins to encroach upon the constraints set by the network agreement criteria (e.g., desired receiver power nears fixed lower bound), it will typically be desired that communication with the desired user be switched to a new frequency. Such encroachment may be caused by degradation in the quality of the communication channel allocated to the desired mobile unit. For example, channel conditions may deteriorate when the desired user becomes located near the edge of the cell area, while simultaneously becoming aligned between the base station and an undesired user in an adjacent cell.

When deteriorating channel conditions cause the network agreement criteria to become in some way "close" to being violated, a search for a new frequency channel may be commenced. This search process will typically continue until either: (i) signal transmission quality over the current frequency channel as defined by the network agreement criteria improves to a satisfactory extent, or (ii) the desired mobile unit is switched to a new frequency channel over which signal transmission complies with the network agreement criteria. It is a feature of the invention that the evaluation of an alternate frequency for transmission to a mobile unit can be accomplished without the need for the mobile to transmit on the frequency under consideration. Using signals received on the alternate frequency, a receive covariance matrix estimate is generated for the alternate frequency. Since there is not a desired user transmitting on the alternate frequency, the undesired covariance matrix  $\mathbf{R}_{alt,u}$  corresponds to the undesired user covariance matrix at the alternate frequency,

$$\mathbf{R}_{alt,\mu} = \sum_{i=1}^{N_{int}} \mathbf{R}_{hRu_i} + \mathbf{R}_n$$

where  $N_{int}$  represents the number of interfering (i.e., undesired) users on the alternate frequency. Again assuming that the covariance matrices are frequency independent for small frequency shifts, the desired covariance matrix estimates

compiled on the previous frequency is equivalent to  $R_{alt,d}$ , the desired user covariance matrix on the alternate frequency. Accordingly, the capability of signal transmission on the alternate frequency to comply with the network agreement criteria may be evaluated in the absence of desired user signal measurement on the  
5 alternate frequency.

It is anticipated that some hardware resources will be dedicated to updating the covariance matrix estimates on unused frequency channels. In doing so, the base station will be disposed to more rapidly find a suitable new frequency channel for a mobile unit assigned to a deteriorating channel. As discussed above,  
10 when mobile units within adjacent cells are located in close proximity, the base stations within the adjacent cells may experience nearly simultaneous channel degradation. That is, the base stations within each cell may simultaneously experience interference on a given frequency channel due to the presence of the undesired co-channel user within the opposing cell. Under these circumstances it  
15 is desirable that only one of the two mobile users be reassigned to a new frequency channel, since this action alone will reduce the interference level experienced by each of the two base stations. One way of increasing the likelihood that only a single mobile user is reassigned is to require that a random time interval expire before any such reassignment may occur. Because each  
20 interval is random, it is highly unlikely that the two proximately located users will be reassigned contemporaneously. Hence, the co-channel interference experienced by each base station is reduced by allocating a new channel to only one of the proximately located mobile users.

In alternate implementations, searches may be performed substantially  
25 contiguously for the most advantageous frequencies over which communication may be maintained with desired mobile units. This is in contrast to the approach previously described, in which a search for a new channel is instigated only upon the transmitted signal power coming sufficiently "close" to a bound set by the network agreement criteria. This alternate approach involves continuously  
30 determining the candidate frequency channel satisfying the transmission quality criteria by the greatest margin. The most advantageous candidate channel may then be selected by, for example, ascertaining which of these optimal transmit

weight beam vectors results in signal transmission best satisfying the pertinent network agreement criteria.

The most advantageous candidate frequency channel could instead be defined as the channel having an optimum transmit weight beam vector with which is associated the largest generalized eigenvalue solution of the applicable optimization function (e.g., equation 11). That is, the optimum transmit weight beam vector is determined for each candidate channel, and the largest eigenvalue associated with this set of weight vectors is then ascertained. The frequency channel corresponding to the transmit weight vector associated with this largest eigenvalue is then identified as the most advantageous frequency channel. Other approaches of utilizing an optimization function to identify a candidate frequency channel satisfying the relevant network agreement criteria are also within the scope of the present invention. It is expected that such other approaches may not identify the most advantageous frequency channel in view of the pertinent network agreement criteria, but will perhaps be capable of determining an acceptable channel in a less computationally intensive manner.

When the procedure outlined in FIG. 5 is used to identify a frequency channel to be assigned in response to a call request to/from a desired mobile unit, it is necessary to accumulate statistics associated with the desired mobile unit before initiating evaluation of candidate frequency channels. The initiation of the evaluation process may be expedited by gathering channel statistics using the pilot channel during the paging or call set-up period. Once suitably accurate receive channel statistics (e.g., receive channel covariance matrix estimates) have been accumulated, channel frequency allocation proceeds in the manner outlined in FIG. 5.

#### IV. Estimating Transmit Channel Covariance Statistics

In accordance with the present invention, any of a number of estimated statistical characterizations of a given receive channel array response vector may be performed as part of the process of generating an optimal transmit beam weight vector. A preferred method of implementing one such statistical characterization, which involves compilation of the aforementioned receive channel covariance

matrix, is described within this section. The method involves statistically characterizing the receive channel associated with the "desired user" to which information is to be transmitted, as well as characterization of the receive channel(s) associated with the "undesired user(s)" that receive interfering signal energy.

This statistical characterization method assumes the availability of a sampled received signal estimate, which is represented as  $\hat{s}_R(kT)$ , wherein "k" denotes the sample time index and "T" the sample interval. In an exemplary embodiment this signal estimate is derived from the output of the receive antenna array 56 (FIG. 2), and may be further processed to enhance signal estimation accuracy. For example, the signal estimate may be obtained by passing the output of the receive array 56, or of another dedicated antenna array, through a spatial and/or temporal receiver equalizer.

In alternate embodiments the signal estimate  $\hat{s}_R(kT)$  is obtained by exploiting a sequence of known training signals which are transmitted from the desired user's mobile unit in order to assist in estimation of the wireless channel properties.

In one embodiment each received signal estimate is cross-correlated with the received data vector  $x_R(kT)$  from the antenna array 56 as a means of forming the instantaneous receive channel array response vector estimate  $\tilde{h}_R(KT)$ . The following cross correlation operation defines  $\tilde{h}_R(KT)$ :

$$\tilde{h}_R(KT) = \frac{1}{2N_h} \sum_{k=K-N_h}^{K+N_h-1} x_R(kT) \hat{s}_R^*(kT) \quad (13)$$

$$K = 0, 2N_h, 4N_h, 6N_h, \dots$$

where  $2N_h$  denotes the number of received data vector samples used to estimate  $\tilde{h}_R(KT)$ . In a preferred implementation the estimation block size is selected such that the time duration ( $2N_h T$ ) of each data block processed during each cross-correlation operation is made to be less than the time scale over which the instantaneous receive channel is expected to vary significantly. In this way an

accurate estimation of instantaneous channel behavior is possible.

Once a set of array response estimates  $\tilde{\mathbf{h}}_R(KT)$  have been collected over a given time interval, a receive channel covariance matrix  $\mathbf{R}_{hRd}$ , may be estimated as follows:

$$\hat{\mathbf{R}}_{hRd}(KT) = \lambda \hat{\mathbf{R}}_{hRd}((K-2Nh)T) + \mu \tilde{\mathbf{h}}_R(KT) \tilde{\mathbf{h}}_R^H(KT) \quad (14)$$

5

Again, the present invention contemplates agreement between such a time-averaged covariance matrix estimation and the true transmit channel short term covariance matrix.

Under certain conditions, the time-averaged covariance matrix estimation may be improved using an estimation filter designed to filter the receive channel response vector estimate  $\tilde{\mathbf{h}}_R(KT)$ . In accordance with the invention, the estimation filter is designed to correlate time-varying frequency and/or spatial properties of the multipath channel. This approach is believed to present a significant departure from conventional techniques, which generally assume near time-invariance over the desired estimation interval. If  $\hat{\mathbf{h}}_R(KT)$  represents the output of the estimation filter in response to the input  $\tilde{\mathbf{h}}_R(KT)$ , the receive covariance matrix associated with the desired user (i.e., "the desired user covariance matrix") may be expressed as:

10

15

$$\hat{\mathbf{R}}_{hRd}(KT) = \lambda \hat{\mathbf{R}}_{hRd}((K-2N_h)T) + \mu \hat{\mathbf{h}}_R(KT) \hat{\mathbf{h}}_R^H(KT) \quad (15)$$

20

25

The estimation filter may be realized as a linear FIR filter, as a linear IIR filter, as an adaptive filter structure (e.g., a Kalman filter), or as a non-linear filter structure. Moreover, the parameters (e.g., FIR taps or Kalman state-space model) of the estimation filter may be pre-computed based on expected channel time-domain correlation behavior. Alternately, the parameters of the estimation filter may be adapted in real-time as a function of measured channel behavior.

Rather than filtering the sequence  $\tilde{\mathbf{h}}_R(KT)$  as means of obtaining an improved array response estimate  $\hat{\mathbf{h}}_R(KT)$ , the estimate of the desired user receive

covariance matrix may first be formulated using only the sequence  $\mathbf{h}_R(KT)$ . The resultant samples  $\tilde{\mathbf{R}}_{hRd}(KT)$  are then passed through an estimation filter similar to that described above to obtain  $\hat{\mathbf{R}}_{hRd}(KT)$ . In this case, however, the estimation filter parameters are selected to directly optimize  $\hat{\mathbf{R}}_{hRd}$ , rather than to indirectly improve this quantity through estimation filtering of  $\hat{\mathbf{h}}_R(KT)$ .

As discussed above, the formulation of an optimal transmit channel covariance matrix involves not only estimation of a desired user receive covariance matrix  $\mathbf{R}_{hRd}$ , but also entails estimation of an undesired user receive covariance matrix  $\mathbf{R}_{hRu}$ . Again, compilation of the undesired user receive covariance matrix involves estimating the interfering signal energy transmitted by mobile users within other cells. One approach to estimation of the undesired user receive covariance matrix  $\mathbf{R}_{hRu}$  involves subtraction of a scaled version of the estimated desired user covariance matrix  $\mathbf{R}_{hRd}$  from the received signal vector covariance matrix  $\mathbf{R}_{xx}$ :

$$\sum_{i=1}^{N_{int}} P_{su_i} \hat{\mathbf{R}}_{hRui}(NT) = \mathbf{R}_{xx}(NT) - P_{s_d} \hat{\mathbf{R}}_{hRd}(NT) = \hat{\mathbf{R}}_u \quad (16)$$

In accordance with another aspect of the invention, an approach for estimating the undesired user covariance matrix is described which is particularly suitable for employment when relatively short sequences of samples (i.e., sample blocks) are being processed. Specifically, the received signal estimate  $\{\hat{\mathbf{h}}(kT)\hat{\mathbf{s}}_d(kT)\}$  is subtracted from the received data vector  $\{\mathbf{x}(kT)\}$ , thereby forming a vector  $\{\mathbf{x}_u(kT)\}$  representative of the sum of the undesired received signal power and receiver noise:

$$\mathbf{x}_u(kT) = \mathbf{x}(kT) - \hat{\mathbf{h}}(kT)\hat{\mathbf{s}}_d(kT) \quad (17)$$

The undesired user covariance matrix  $\hat{\mathbf{R}}_{hRu}$  is then estimated as follows:



$$\hat{R}_u(KT) = \lambda \hat{R}_u((K-2N_h)T) + \mu \sum_{k=K-N_h}^{k+n_h-1} x_u(kT)x_u^H(kT) \quad (18)$$

As was mentioned above in connection with description of the desired covariance matrix  $R_{bRd}$ , it may at times be desirable to filter samples of the undesired covariance matrix using an estimation filter. Again, such an estimation filter serves to modify the current estimated covariance matrix in response to time-variation in the statistics of the true undesired channel response.

Following determination of the estimated desired and undesired receive channel covariance matrices, the optimal transmit beam weight vector is found by substituting these matrices into equation (11) as follows:

$$\hat{R}_k R_d \rightarrow \hat{R}_k T d \quad (19)$$

10

$$\hat{R}_u \rightarrow \sum_{i=1}^{N_{int}} R_k T u_i$$

15

The foregoing procedure for optimal transmit beamforming illustrates a particular implementation of the invention, it being understood that other methods for adaptively estimating channel covariance are also within the scope of the invention.

V. Transmit and Receive Channel Calibration

In order to ensure that receive channel statistics are accurately "mapped" to transmit channel statistics which are useful for determining an optimal transmit beam weight vector, the transmit and receive sections of the particular transceiver employed are calibrated. The calibration procedure and apparatus described herein corrects for differences in the amplitude and phase match between the signal paths through the transceiver corresponding to each antenna element of the frequency

20

channels. This "matching" correction allows receive channel statistics collected for each of the frequency channel to be accurately used within the corresponding transmit channel in the manner described in section IV. Although several specific approaches of a calibration procedure are set forth below, other approaches of

5 correcting for amplitude and phase discrepancies between corresponding transmit and receive channel paths may be apparent to those skilled in the art in view of the teachings herein.

Referring to FIG. 6, a block diagram is provided of an exemplary calibration system as incorporated within the adaptive beamforming network of

10 FIG. 3. The calibration procedure contemplated by the invention involves two operations: (i) calibration of the antenna array 56 and diplexer 58, and (ii) calibration of the remaining electronics within the transmit and receive sections.

Since the antenna array 56 and diplexer 58 (i.e., the array assembly) are comprised of passive components, it is expected that matching (e.g., power

15 matching, impedance matching) between these passive structures and both the transmit and receive and electronics will be relatively invariant over time and temperature. Accordingly, calibration of the matching between the array assembly and the remaining transmit and receive electronics within the adaptive beamforming network may be performed infrequently. As a first step in

20 calibration of the array assembly, the match between the RF receiver 54 and the array assembly is determined for each receive frequency of interest. Similarly, the match between the RF transmitter 52 and the array assembly is also determined for each transmit frequency of interest. These measurements may be conducted at an antenna test range, or at any other appropriate calibration site.

The differences in the measured amplitude and phase match for each

25 corresponding pair of transmit and receive frequencies are stored both within a receiver calibration equalizer & channelizer 250, and within a transmitter calibration equalizer & channel combiner 254. During operation of the adaptive beamforming network, equalization filters within the equalizers 250 and 254 are

30 adjusted so as to compensate for the matching difference at each pair of corresponding transmit and receive frequencies.

Unlike the array assembly, the active components within RF transmitter 52

and RF receiver 54 may exhibit significant amplitude and phase drift as a function of time and temperature. In order to obviate the need for use of expensive, high-precision components in conjunction with compensation circuits as a means of minimizing such amplitude and phase drift, the present invention contemplates utilization of the self-calibration apparatus depicted within FIG. 6. The self-calibration technique described herein involves compensating for differences in amplitude and phase between the different propagation paths within the RF transmitter 52 associated with each antenna element, and likewise for such differences between the different propagation paths within the RF receiver 54. Measurements of the propagation of calibration signals over each path within the RF transmitter 52, and separately within the RF receiver 54, are conducted at each of the  $N$  transmit/receive frequency pairs of interest. The measurement results are then employed to compute calibration coefficients used in adjustment of the equalizers 250 and 254.

Referring to the receive section of FIG. 6, a receiver calibration signal injection network 260 is operative to generate calibration signal comprised of all the  $N$  RF receive frequencies of interest. This "wideband" calibration excitation may be accomplished either through generation of a plurality of discrete frequency signals, or through generation of a single wideband calibration signal. In either case, the same one or more receiver calibration signals are injected into each of the  $M$  signal paths linking each of the  $M$  elements of the array 56 to the RF receiver 54. After being downconverted in frequency, digitized, filtered and decimated within the receiver 54, the receiver calibration signals are processed by a receiver calibration coefficient computation circuit 264. In the exemplary embodiment, the computation circuit 264 measures the amplitude and phase difference exhibited by calibration signals of the same frequency after propagation through the receiver 54 on the  $M$  different signal paths associated with the antenna elements. A set of filter calibration coefficients are then computed for use in adjustment of either a single wideband equalization filter, or a plurality of narrowband equalization filters, disposed within the receiver calibration equalizer 250.

As mentioned above, calibration information obtained during calibration of

the array assembly is also stored within the calibration equalizer. This calibration information, as well as the coefficients provided by the computation circuit 264, are together used to adjust the equalization filters within the calibration equalizer 250. This adjustment is designed to ensure that for each of the  $N$  frequency  
5 channels, a substantially identical amplitude and phase change occurs as a consequence of propagation through each of the  $M$  propagation paths of the RF receiver 54.

A similar calibration procedure may be used to compensate for the generally different amplitude and phase characteristics exhibited by each of the  $M$   
10 signal propagation paths within the RF transmitter 52. In particular, a set of  $M$  identical wideband digital IF calibration signals are generated within a transmitter calibration signal injection network 274 for application to the  $M$  signal paths entering the RF transmitter 52. Each of these  $M$  wideband digital IF calibration signals are then interpolated,  
15 filtered, converted to analog signals, and subsequently translated to a higher analog frequency.

At the output of the bank of power amplifiers 164, the amplified calibration signals are coupled to a transmit section calibration receiver comprised of an RF calibration downconverter 280 and an A/D conversion & digital processing module  
20 284. The RF calibration downconverter 280 is operative to translate the frequency of the amplified calibration signals to an intermediate frequency (IF). The resultant set of  $M$  IF signals are provided to an A/D conversion & digital processing module 284 disposed to digitize, filter, and decimate each IF signal. A transmitter calibration coefficient computation circuit 288 then measures the  
25 amplitude and phase difference exhibited by calibration signals of the same frequency carried by the  $M$  different outputs of the A/D conversion & digital processing module 284 where, again, each of the  $M$  outputs is associated with one of the  $M$  signal paths through the RF transmitter.

A set of filter calibration coefficients are then computed within the  
30 computation circuit 288 for use in adjustment of the single wideband, or multiple narrowband, equalization filters disposed within the transmitter calibration equalizer and channel combiner 254. These filter calibration coefficients, as well

as the calibration information collected during calibration of the array assembly, are jointly used to adjust the equalization filters within the calibration equalizer & channel combiner 254.

The transmit section calibration receiver will typically also be calibrated in a manner substantially similar to that described above with reference to the RF receiver 54. In order to preserve clarity of representation, the calibration circuitry used in this secondary calibration process is not shown in FIG. 6. Finally, it is noted that the calibration system depicted in FIG. 6 is designed to be equally compatible with an adaptive beamforming network equipped with separate transmit and receive antenna arrays. The implementation of the calibration system within such an adaptive beamforming network is shown in FIG. 7.

FIG. 8 provides a block diagram of a self-calibrated adaptive beamforming network in which the receive section of the beamforming network is advantageously utilized in lieu of a transmit section calibration receiver (FIG. 6). During calibration of the transmit section of the beamforming network, the transmitter signal injection network 284 again applies a wideband calibration signal to each of the  $M$  inputs to the RF transmitter 52. A transmit calibration switch 302 is operated, during calibration, so as to sequentially couple each one of the  $M$  calibration outputs of the RF transmitter 52 to a single one of the  $M$  inputs to the RF receiver 54. In the embodiment of FIG. 8, the bandwidth of the RF receiver 54 encompasses both the transmit and receive channel frequency spectra in order to facilitate processing of the transmit section calibration signals. Based on the content of the calibration signals processed by the RF receiver 54, the transmitter calibration coefficient computation circuit 288 then computes a set of filter calibration coefficients for use in adjustment of the equalization filter(s) disposed within the transmitter calibration equalizer and channel combiner 254.

The transmit calibration switch 302 similarly obviates the need for a receiver calibration signal injection network 260 (FIG. 6). In particular, during calibration of the receive section of the adaptive beamformer, a receive calibration switch 306 is closed so as to allow a receive channel calibration signal generated by one of the  $M$  paths of the RF transmitter 52 to be applied to the RF receiver 54. Calibration coefficients would then be computed by the receiver calibration

coefficient computation circuit 264 in the manner described above. In this implementation, the bandwidth of the RF transmitter 52 is designed to accommodate the spectra occupied by both the set of transmit channels and the set of receive channels.

5           As mentioned above, both the calibration equalizer and channelizer 250 and the transmitter calibration equalizer & channel combiner may each include either: (i) a single wideband equalization filter, or (ii) a functionally equivalent set of narrowband equalization filters. Referring to FIG. 9, a block diagram is provided of an implementation of a calibration equalizer and channelizer 250 in which a  
10       single wideband calibration equalizer 320 is coupled to each of the  $M$  outputs of the complex downconverter 112 of the RF receiver 54. During operation of the adaptive beamforming network, the passband characteristics of each wideband calibration equalizer 320 are adjusted on the basis of the results of the previously described calibration procedures. As is indicated by FIG. 9, the equalized output  
15       of each of the  $M$  wideband calibration equalizers 320 is demultiplexed into a set of  $N$  independent frequency channels by channelizer 324. Within the receive channel weighting network 116 (FIG. 1), a set of  $N$  space-time equalizers 330 each receive the output produced by the channelizers 324 on a different one of the  $N$  frequency channels. Each space-time equalizer 330 is disposed to scale signal energy within  
20       its assigned frequency channel pursuant to the weighting vector provided the receiver weight vector adaptation network 118, the operation of which was described in sections I and II.

          In FIG. 10, a block diagram is provided of an implementation of a  
25       transmitter calibration equalizer & channel combiner 250 in which a single transmit wideband calibration equalizer 350 precedes each of the  $M$  inputs to the complex upconverter 160 of the RF transmitter 52. During operation of the adaptive beamforming network, the passband characteristics of each transmit wideband calibration equalizer 350 are adjusted on the basis of the results of the previously described calibration procedures. As is indicated by FIG. 10, the  
30       frequency-multiplexed input of each of the  $M$  wideband calibration equalizers 350 is provided one of a set of  $M$  channel combiners 360. Each of the  $M$  channel combiners 360 receives input on a different one of the  $N$  frequency channels from

a set of  $N$  transmission beamformers 370 within the transmit channel weighting network 158 (FIG. 1). The scaling introduced by the  $N$  transmission beamformers 370 is predicated on the composition of the transmit beam weight vector generated by the transmitter weight vector adaptation network 150 (FIG. 1).

5           FIG. 11 is a block diagram of an implementation of the calibration equalizer and channelizer 250 which, although functionally equivalent to the structure of FIG. 9, utilizes  $M$  sets of  $N$  narrowband calibration equalizers 390 rather than  $M$  wideband equalizers. In addition, in the implementation of FIG. 11 the channelization operation is performed prior to equalization. Accordingly, each  
10 of the  $M$  channelizers 324 provides output on a different frequency channel to each of the  $N$  narrowband calibration equalizers 390 associated therewith.

          FIG. 12 depicts a transmitter calibration equalizer & channel combiner 250 functionally identical to that shown in FIG. 10, but within which the equalization function is performed separately for each channel prior to the frequency  
15 multiplexing operation. Specifically, a separate set of  $M$  narrowband calibration equalizers 410 are seen to be coupled to each transmission beamformer 370. In turn, the  $N$  calibration equalizers 410, coupled to a set of the  $M$  channel combiners 360, are each operative to produce an equalized signal on each of the  $N$  available frequency channels.

20

#### VI. Alternate Embodiments

          Although the embodiments of the invention presented herein have been described in terms of optimization of the antenna pattern transmitted by a base station antenna array, the teachings of the invention are equally applicable to  
25 optimum formation of the mobile unit antenna pattern. That is, the mobile unit antenna pattern is formed such that a desired level of power is transmitted to the one or more base stations with which the mobile unit is in communication, and so that transmission power is minimized to the other base stations within the communication network. Again, an initial step in this antenna pattern optimization  
30 procedure involves statistically characterizing the mobile unit receive channel vector. The results of this statistical characterization are then used to determine the beam pattern weight vector which maximizes a predetermined quality

parameter (e.g., signal to noise ratio) of the signal received by the intended base station(s), while minimizing signal transmission to other base stations. At the mobile station, the transmit antenna beam pattern is then generated in accordance with the transmit beam pattern weight vector.

5           Accordingly, in the following claims the term "central communications station" is intended to refer to either the base station or mobile unit configured to generate an optimized antenna beam pattern in accordance with the invention. When a base station comprises the central communications station, the mobile unit(s) in communication therewith are referred to as "remote communications  
10 station(s)". Conversely, when a mobile unit comprises the central communications station, the receiving base station(s) are identified as remote communications station(s).

15           While the present invention has been described with reference to a few specific embodiments, the description is illustrative of the invention and is not to be construed as limiting the invention. Various modifications may occur to those skilled in the art without departing from the true spirit and scope of the invention as defined by the appended claims.



## WHAT IS CLAIMED IS:

1. In a communications system including a central communications station and at least one remote communications station, said central communications station having an antenna array for generating an antenna beam pattern used for transmission of information signals received by said remote communications station, a method for adaptively forming said beam pattern comprising the steps of:
- 5 statistically characterizing a receive channel vector, said receive channel vector being representative of a receive communications channel over which signal energy is transmitted from said at least one said remote communications station to said central communications station;
- 10 generating a beam pattern weight vector based on results of statistical characterization of said receive channel vector, said beam pattern weight vector being generated in accordance with a predetermined quality measurement of said information signals received by said remote communications station; and
- 15 forming said beam pattern using said beam pattern weight vector.
2. The method of claim 1 further including the step of estimating said receive channel vector using one or more time-varying channel estimation filters.
- 20
3. The method of claim 1 wherein said step of statistically characterizing further includes the step of compiling an estimated receive channel covariance matrix.
- 25
4. The method of claim 3 wherein said step of generating said beam pattern weight vector includes the step of time averaging said estimated receive channel covariance matrix in order to form an estimated transmit channel covariance matrix.
- 30
5. The method of claim 4 further including the step of using said estimated transmit channel covariance matrix to form objective and constraint functions from

which said beam pattern weight vector is determined.

6. In a communications system including a central communications station and at least one remote communications station, said central communications station having an antenna array for generating an antenna beam pattern used for transmission of information signals received by said remote communications station, a system for adaptively forming said beam pattern comprising:
- 5 means for statistically characterizing a receive channel vector, said receive channel vector being representative of a receive communications channel over which signal energy is transmitted from said at least one remote communications station to said central communications station;
- 10 means for generating a beam pattern weight vector based on results of statistical characterization of said receive channel vector, said beam pattern weight vector being generated in accordance with a predetermined quality measurement of said information signals received by said remote communications station; and
- 15 a beamforming network for forming said beam pattern using said beam pattern weight vector.
7. The system of claim 6 further including one or more time-varying channel estimation filters for estimating said receive channel vector.
- 20
8. The system of claim 6 wherein said means for statistically characterizing further include means for compiling an estimated receive channel covariance matrix.
- 25
9. The system of claim 8 wherein said means for generating said beam pattern weight vector includes means for averaging said estimated receive channel covariance matrix in order to form an estimated transmit channel covariance matrix.
- 30
10. The system of claim 9 further including means for using said estimated transmit channel covariance matrix to form objective and constraint functions, said

beam pattern weight vector being obtained by solving said objective and constraint functions.

11. In a cellular communications system including a base station and at  
5 least one mobile unit, said base station having an antenna array for projecting a  
transmit antenna beam pattern used for transmission of information signals to said  
mobile unit, a system for adaptively forming said transmit antenna beam pattern  
comprising:

10 a receive channel beamforming network for processing signal energy  
transmitted by said at least one mobile unit over a receive communications channel  
to said antenna array, said receive channel beamforming network including means  
for producing a statistical characterization of a receive channel vector wherein said  
receive channel vector is representative of said receive communications channel;  
and

15 a transmit channel beamforming network for generating a transmit beam  
pattern weight vector based on said statistical characterization, and for forming  
said transmit antenna beam pattern using said transmit beam pattern weight vector;  
wherein said transmit beam pattern weight vector is generated so as to  
improve quality of signal reception within said mobile unit.

20

12. The system of claim 11 further including a diplexer connected between  
said antenna array and said transmit and receive channel beamforming networks.

13. The system of claim 11 wherein said receive channel beamforming  
25 network further includes:

means for generating a receive channel weight vector, and means for  
scaling signal energy received by antenna elements of said antenna array in  
accordance with said receive channel weight vector.

30 14. The system of claim 11 wherein said means for producing a statistical  
characterization of a receive channel vector further includes means for compiling  
an estimated receive channel covariance matrix.

15. The system of claim 14 wherein said transmit channel beamforming network includes:

means for averaging said estimated receive channel covariance matrix in order to form an estimated transmit channel covariance matrix, and

5 means for deriving said transmit beam pattern weight vector from said transmit channel covariance matrix.

16. The system of claim 15 wherein said means for deriving said transmit beam pattern weight vector includes means for determining the principal  
10 eigenvector of said transmit channel covariance matrix, said transmit beam pattern weight vector corresponding to said eigenvector of said transmit channel covariance matrix.

17. The system of claim 11 further including calibration means for  
15 calibrating said transmit and receive channel networks.

18. The system of claim 17 wherein said calibration means includes:

means for applying a set of test signals to a corresponding set of output ports of elements of said antenna array, and

20 means for measuring amplitude change and phase shift of each of said test signals arising due to propagation over receive channel paths within said receive channel network.

19. The system of claim 18 wherein said calibration means includes means  
25 for equalizing amplitude and phase response through said receive channel paths based on measured phase shift of said test signals.

20. The system of claim 17 wherein said calibration means includes:

means for applying a set of test signals to said transmit channel network,  
30 and

means for measuring amplitude change and phase shift of each of said test signals within said set of test signals arising due to propagation over transmit

channel paths within said transmit channel network to a corresponding set of antenna elements of said antenna array.

21. The system of claim 20 wherein said calibration means includes means  
5 for equalizing amplitude and phase response through said transmit channel paths based on measured phase shift of said test signals.

22. In a cellular communications system including a base station and at least one mobile unit, said base station having transmit and receive antenna arrays  
10 for providing transmit and receive antenna beam patterns, respectively, a system for adaptively forming said transmit antenna beam pattern comprising:

a receive channel beamforming network, operatively coupled to said receive antenna array, said receive channel beamforming network including means for producing a statistical characterization of a receive channel vector wherein said  
15 receive channel vector is representative of a receive communications channel over which information is transmitted from said at least one mobile unit; and

a transmit channel beamforming network, operatively coupled to said transmit antenna array, for generating a transmit beam pattern weight vector based on said statistical characterization and for forming said transmit antenna beam  
20 pattern using said transmit beam pattern weight vector.

23. The system of claim 22 wherein said means for producing a statistical characterization of a receive channel vector further includes means for compiling an estimated receive channel covariance matrix.  
25

24. The system of claim 23 wherein said transmit channel beamforming network includes:

means for time-averaging said estimated receive channel covariance matrix in order to form an estimated transmit channel covariance matrix, and

30 means for deriving said transmit beam pattern weight vector from said transmit channel covariance matrix.

25. In a radio frequency communications system including a central communications station having an antenna array, a method for forming a transmit antenna beam pattern comprising the steps of:

5 adaptively beamforming a signal received from a remote communications unit in order to configure a receiver beam weighting network;

determining an estimated receive channel vector using said signal received from said remote communications unit, said estimated receive channel vector being determined at least partly in accordance with a beamformed signal generated by said receiver beam weighting network; and

10 transmitting a beamformed signal to said remote communications unit based upon said estimated receive channel vector.

26. The method of claim 25 wherein said step of transmitting further includes the step of averaging said estimated receive channel vector.

15

27. The method of claim 25 wherein one or more time-varying channel estimation filters are used to determine said estimated receive channel vector.

28. In a radio frequency communications system including a central communications station having an antenna array, a system for adaptively forming a transmit antenna beam pattern comprising:

20 means for adaptively beamforming a signal received from a communications unit in order to configure a receiver beam weighting network;

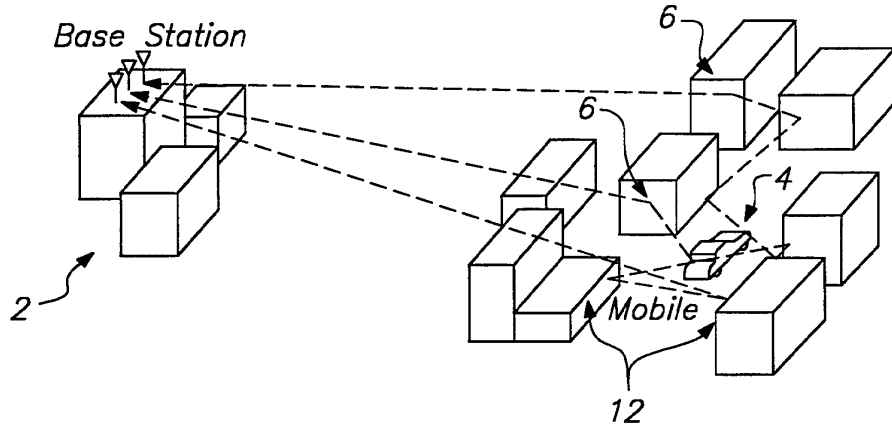
25 means for determining an estimated receive channel vector using said signal received from a communications unit, said estimated receive channel vector being determined at least partly in accordance with a beamformed signal generated by said receiver beam weighting network; and

a transmit beamforming network for transmitting a beamformed signal to said communications unit based upon said estimated receive channel vector.

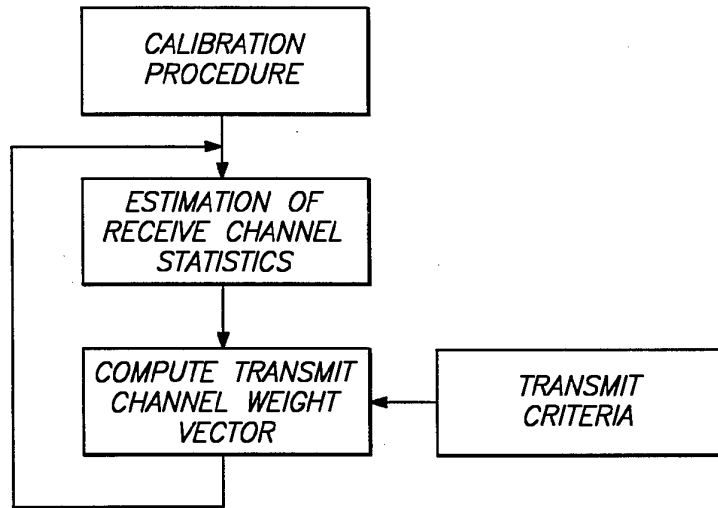
30

29. The system of claim 28 wherein said transmit beamforming network includes means for averaging said estimated receive channel vector.

30. The system of claim 28 wherein said means for determining said receive channel vector includes one or more time-varying channel estimation filters.



**FIG. 1**



**FIG. 4**

**SUBSTITUTE SHEET (RULE 26)**



2/11

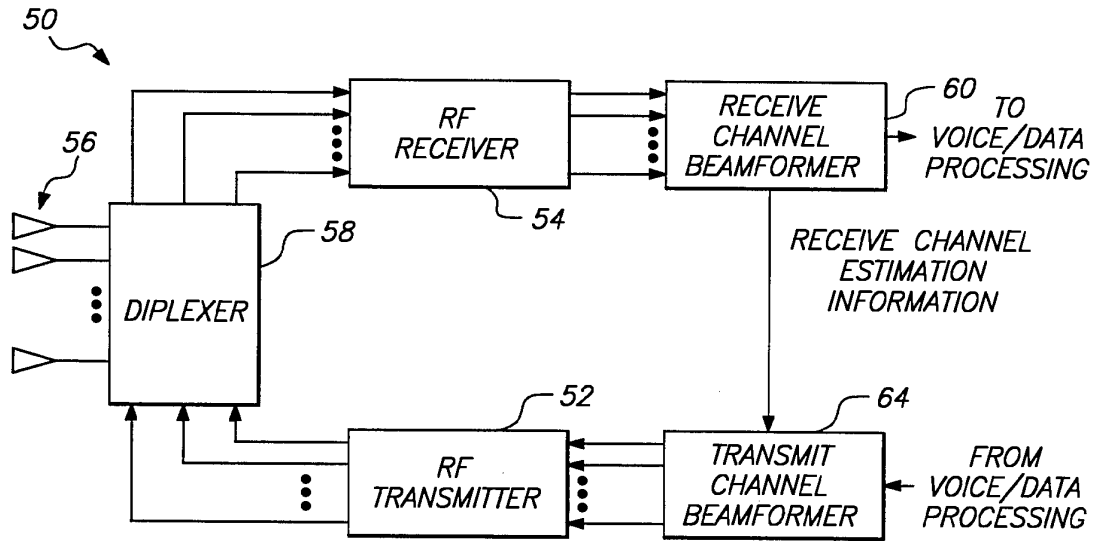


FIG. 2A

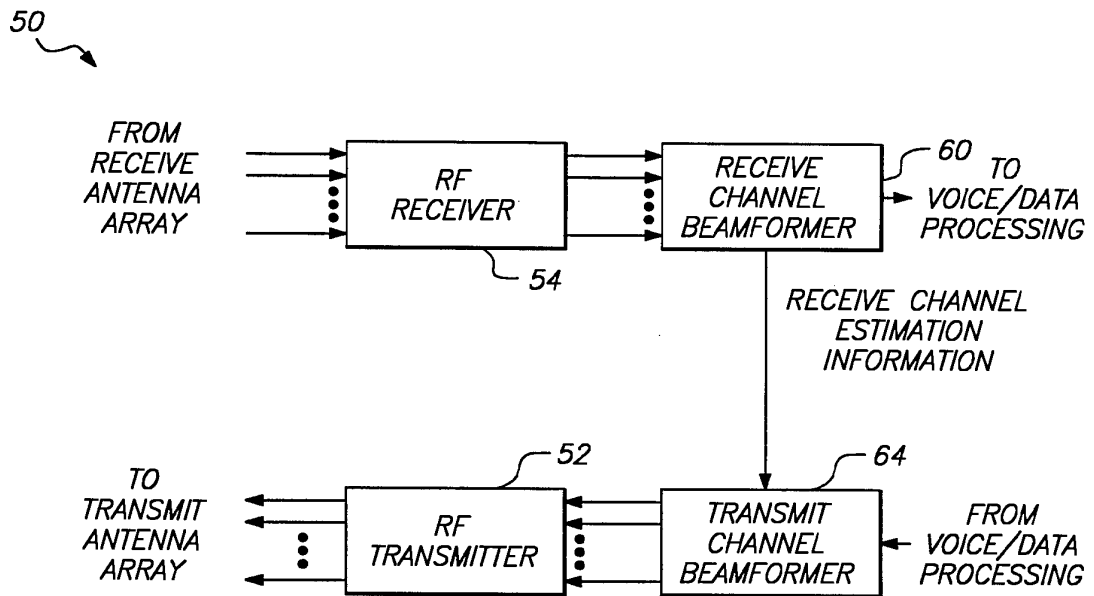


FIG. 2B

SUBSTITUTE SHEET (RULE 26)

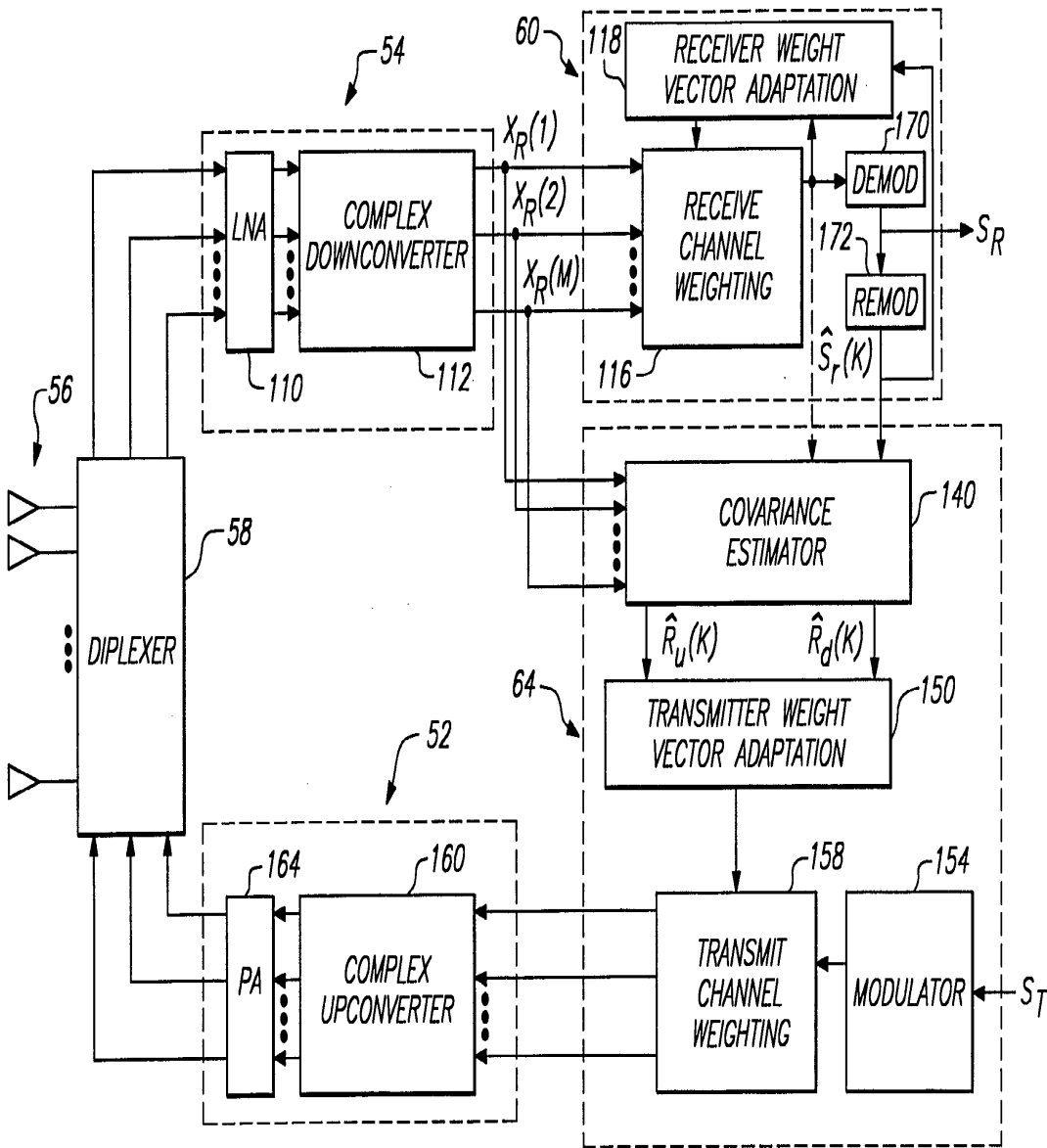
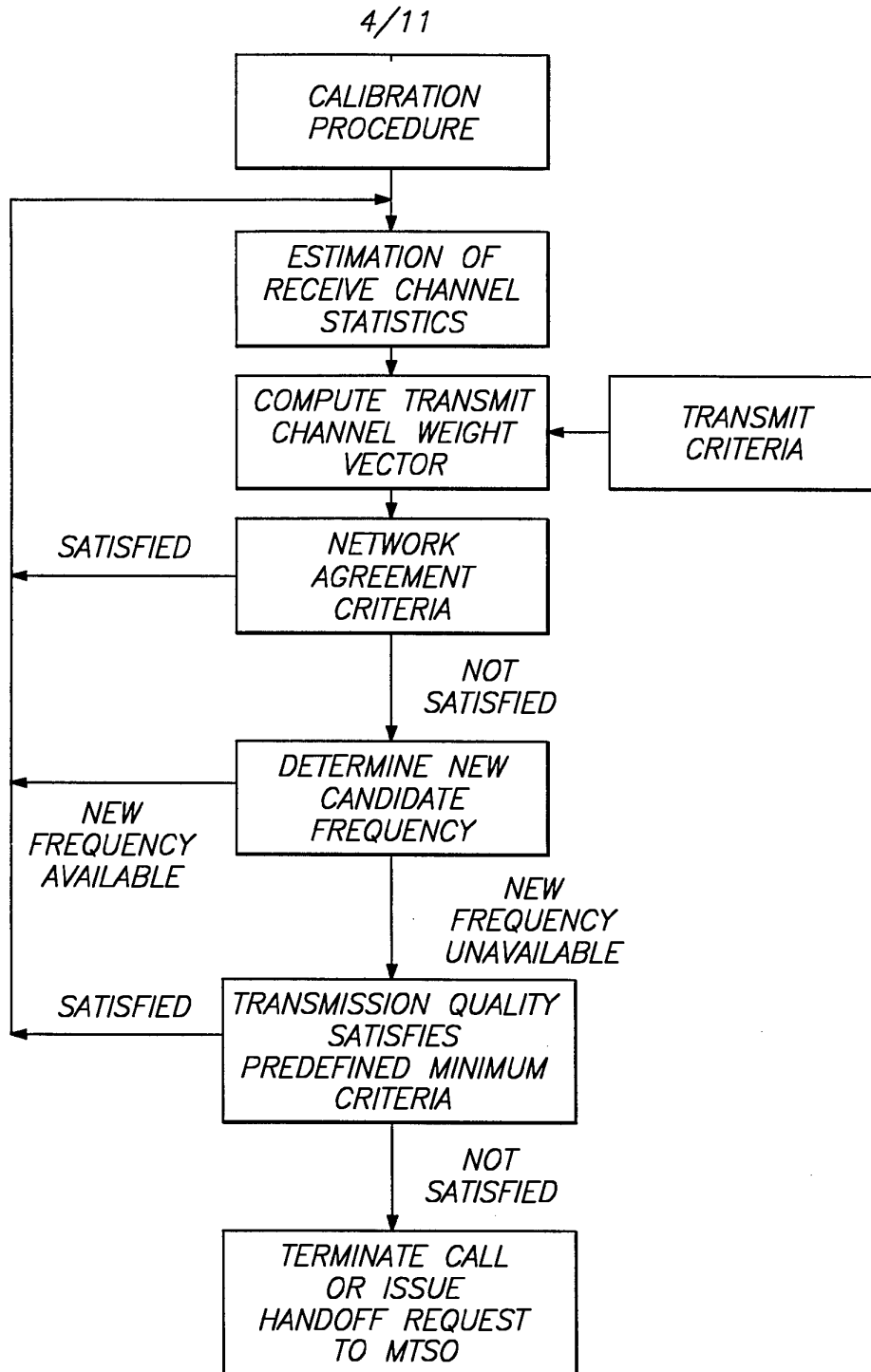


FIG. 3



**FIG. 5**  
**SUBSTITUTE SHEET (RULE 26)**

5/11

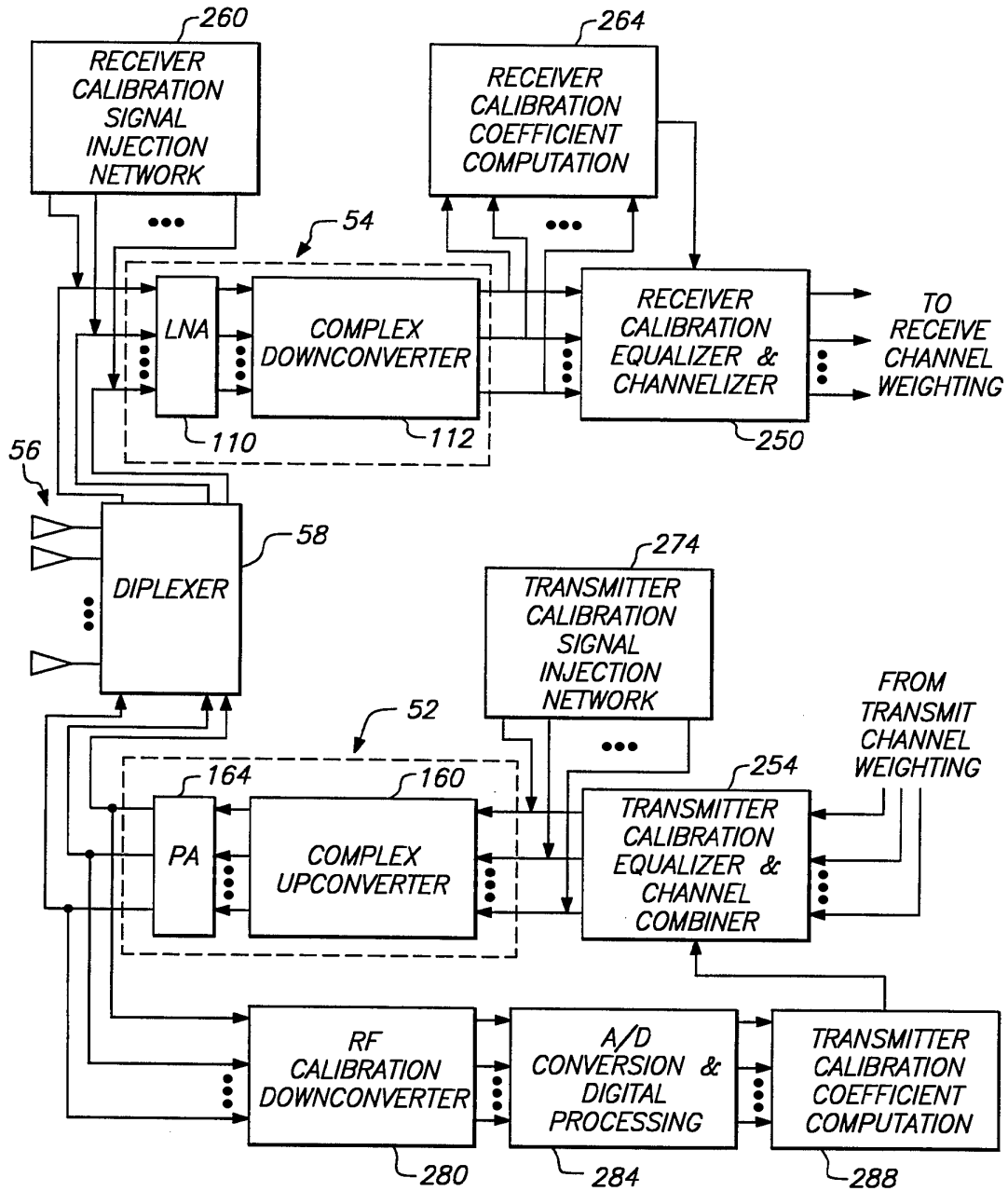


FIG. 6

SUBSTITUTE SHEET (RULE 26)

6/11

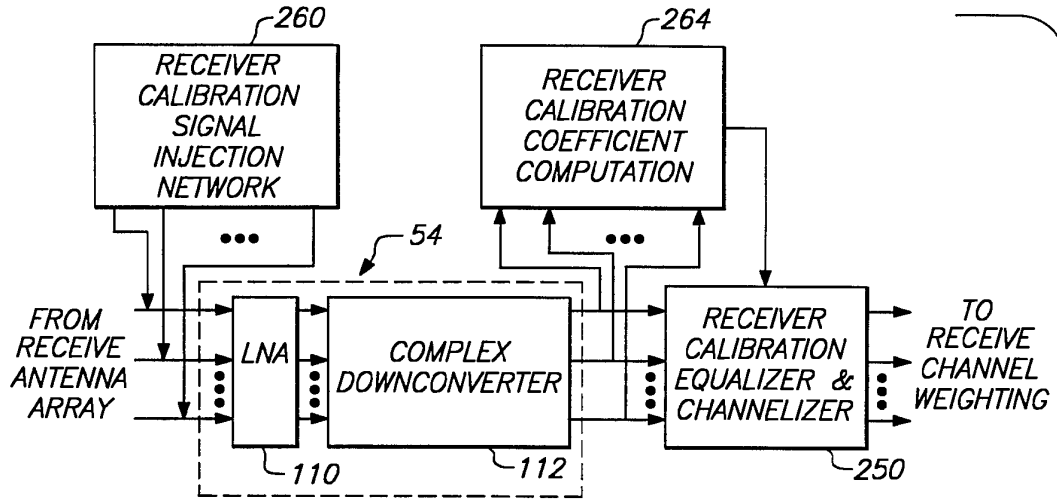
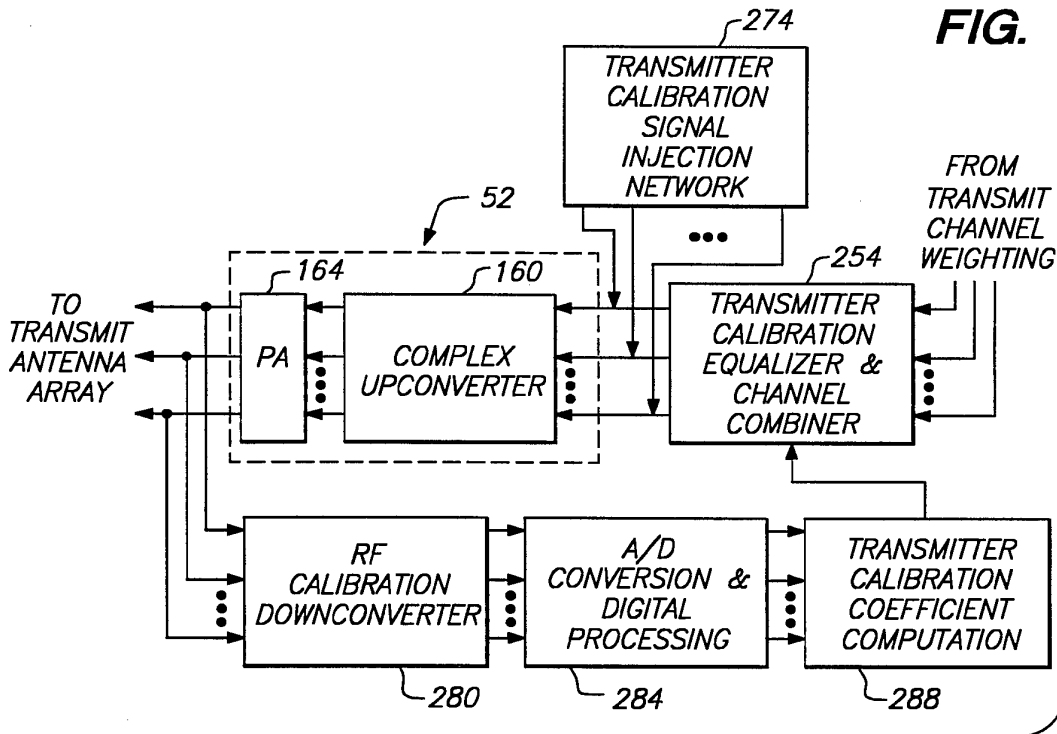


FIG. 7



SUBSTITUTE SHEET (RULE 26)

7/11

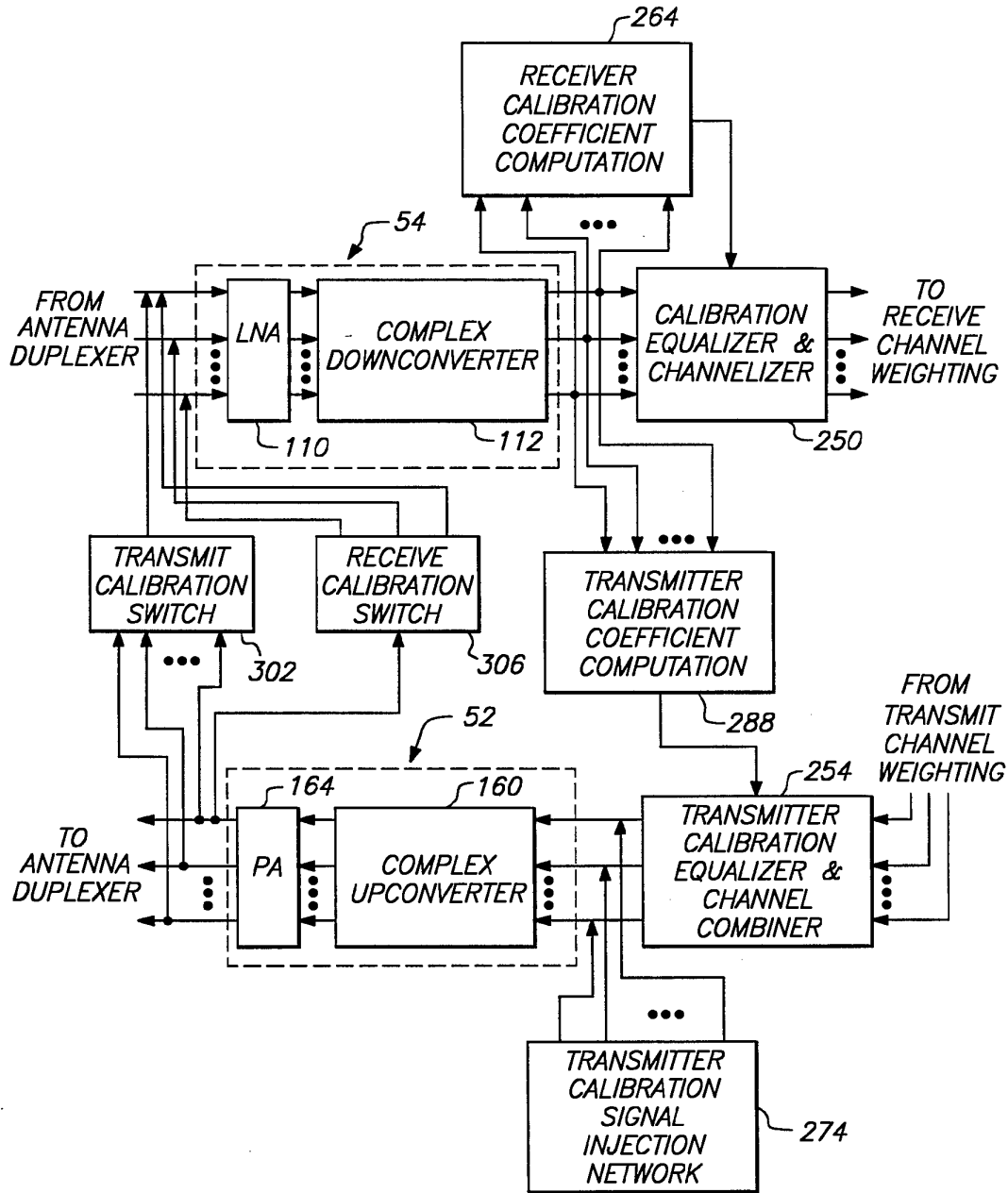


FIG. 8

SUBSTITUTE SHEET (RULE 26)

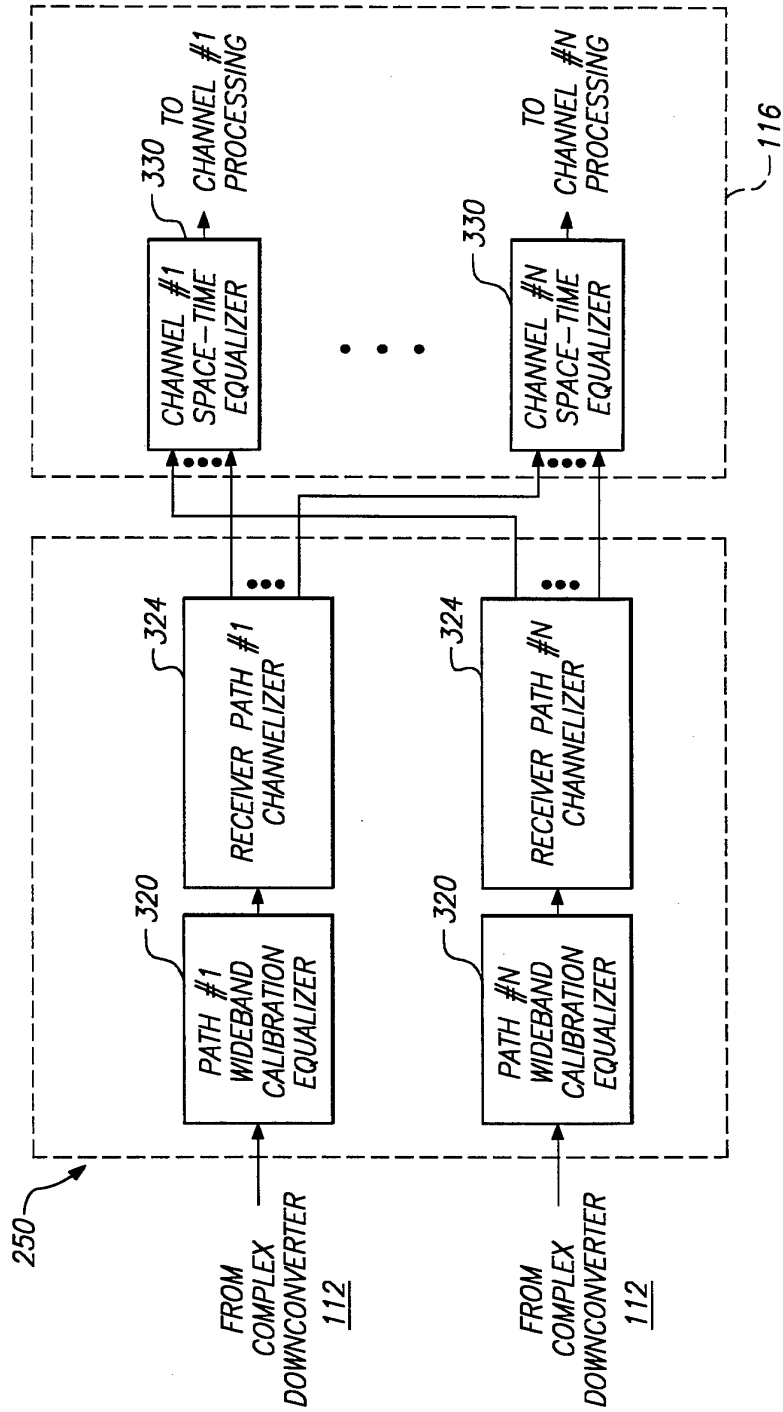


FIG. 9

SUBSTITUTE SHEET (RULE 26)

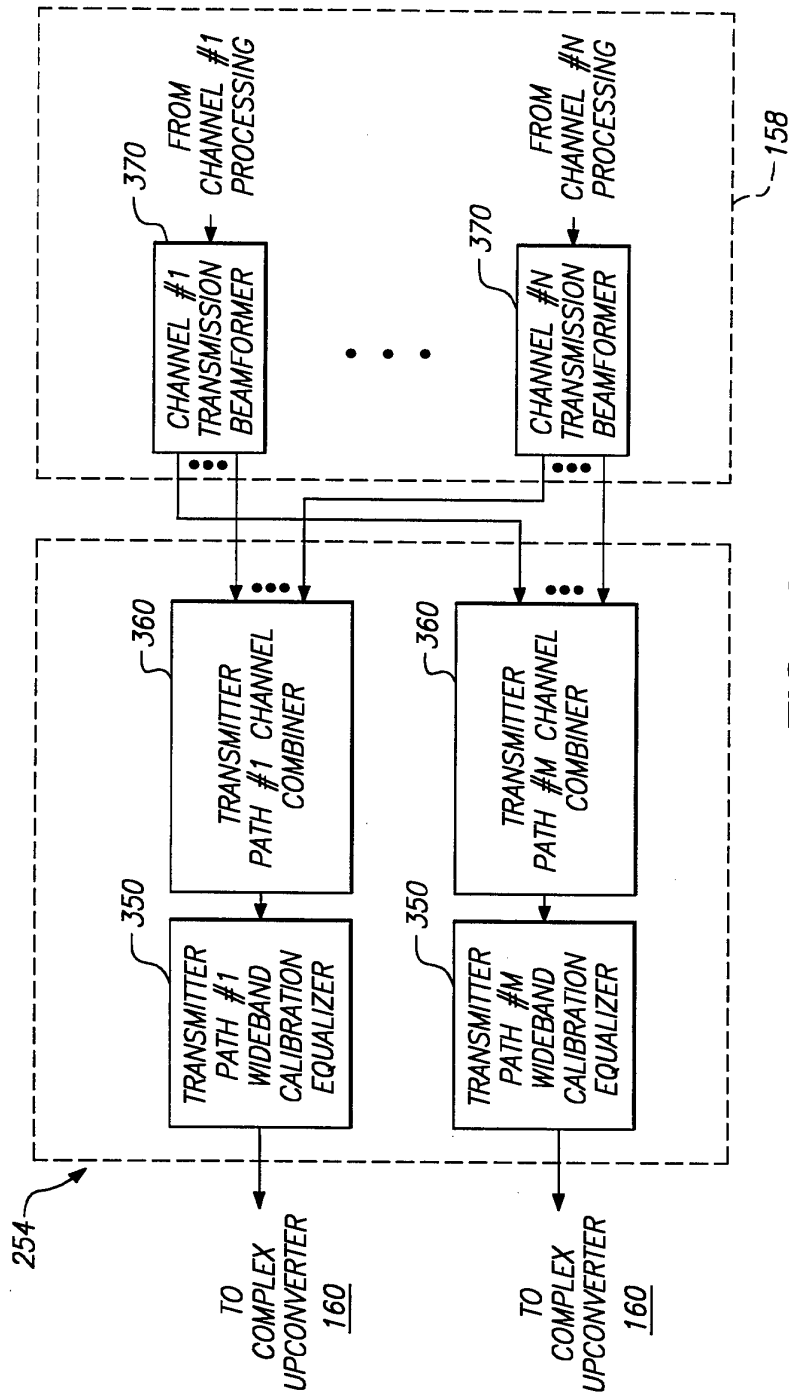


FIG. 10

SUBSTITUTE SHEET (RULE 26)



10/11

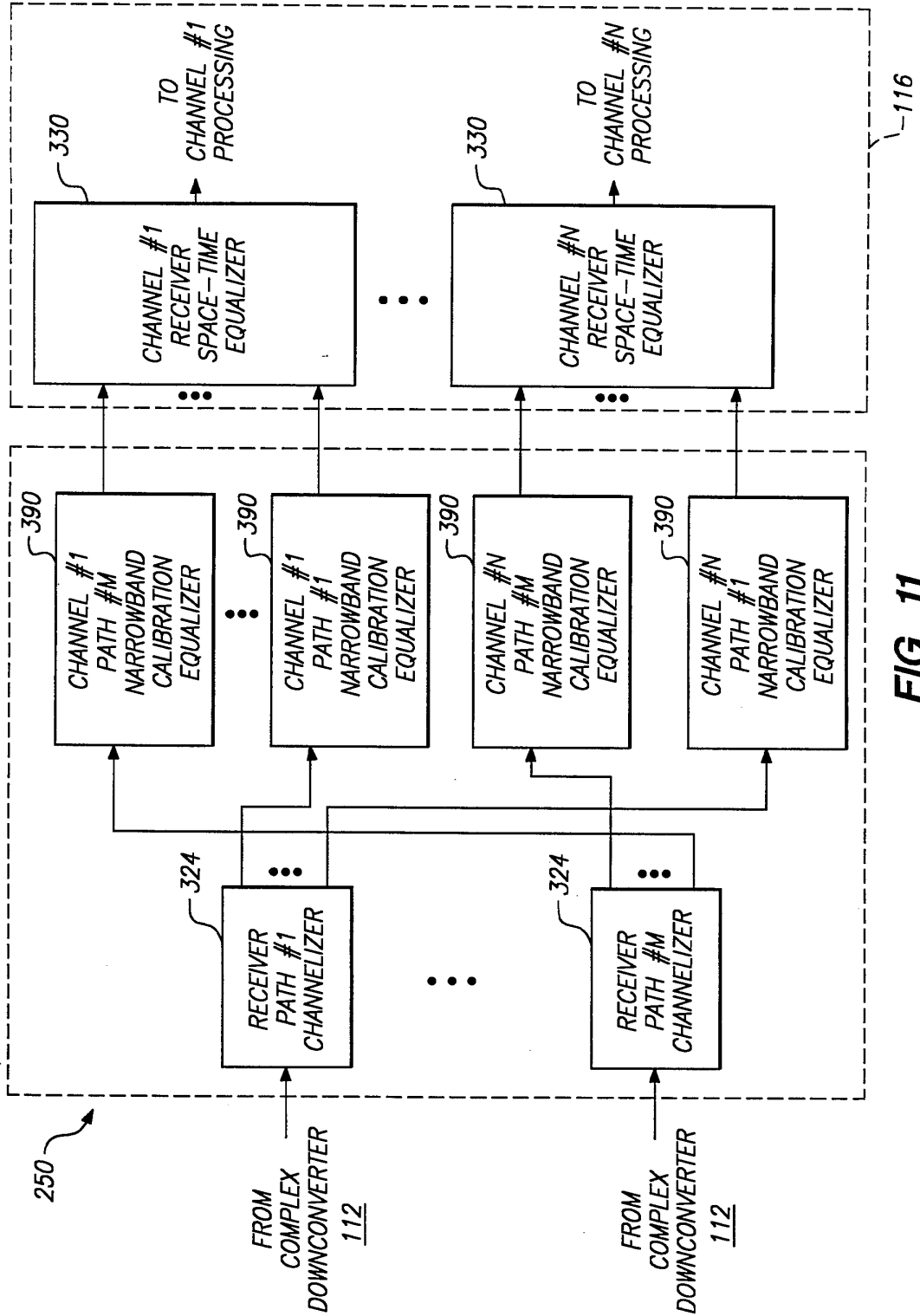


FIG. 11

SUBSTITUTE SHEET (RULE 26)

11/11

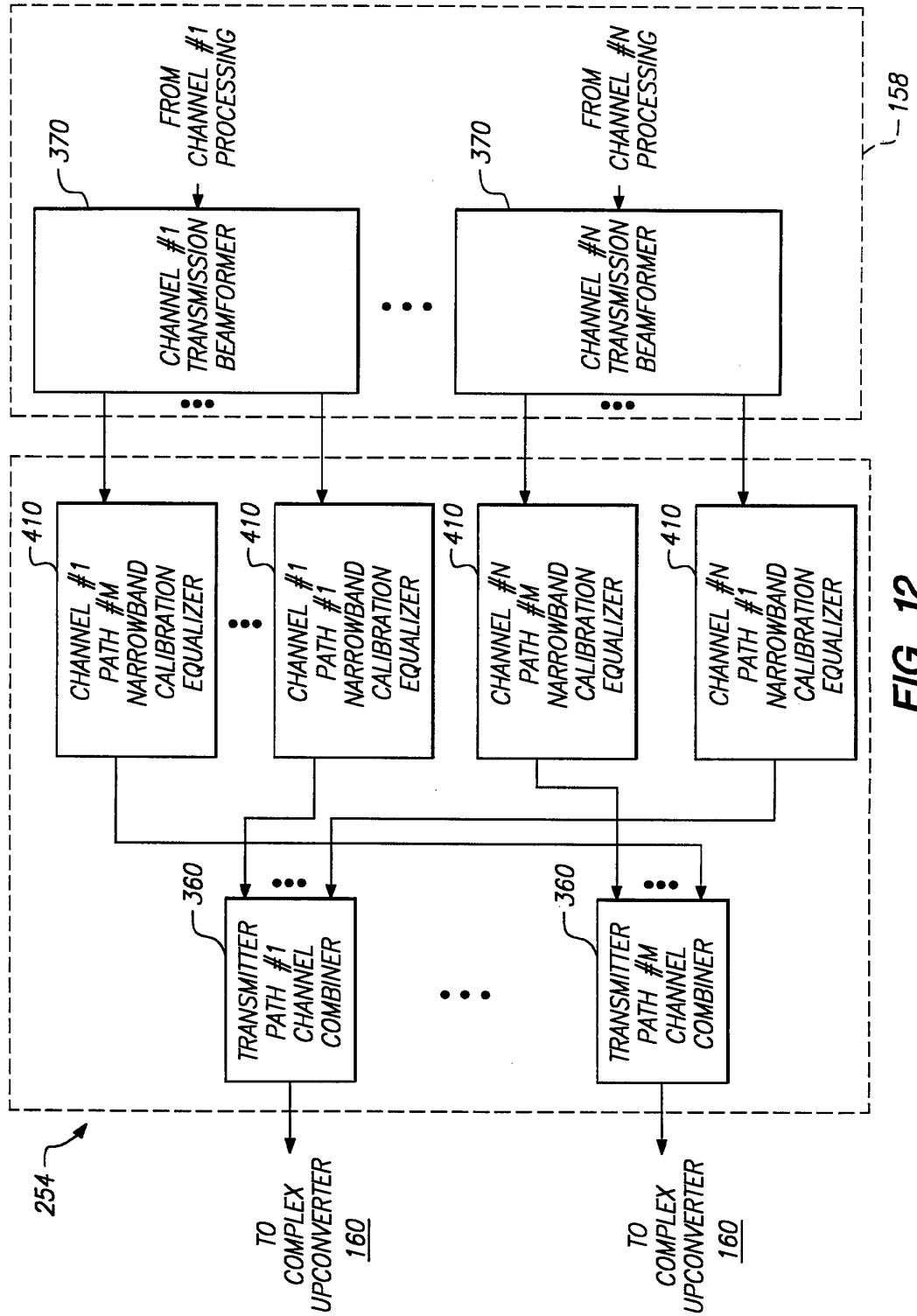


FIG. 12

SUBSTITUTE SHEET (RULE 26)

**INTERNATIONAL SEARCH REPORT**

International Application No  
PCT/US 96/08564

<b>A. CLASSIFICATION OF SUBJECT MATTER</b> IPC 6 H01Q25/00 H01Q3/26		
According to International Patent Classification (IPC) or to both national classification and IPC		
<b>B. FIELDS SEARCHED</b> Minimum documentation searched (classification system followed by classification symbols) IPC 6 H01Q		
Documentation searched other than minimum documentation to the extent that such documents are included in the fields searched		
Electronic data base consulted during the international search (name of data base and, where practical, search terms used)		
<b>C. DOCUMENTS CONSIDERED TO BE RELEVANT</b>		
Category *	Citation of document, with indication, where appropriate, of the relevant passages	Relevant to claim No.
Y	WO,A,94 09568 (E-SYSTEMS) 28 April 1994 see abstract; figures 1-6 ---	1,6,11, 22,28
Y	EP,A,0 142 293 (NEC) 22 May 1985 see abstract; claims 1-4; figure 2 ---	1,6,11, 22,28
A	GB,A,2 266 998 (MOTOROLA) 17 November 1993 see abstract; claims 1-17; figures 2-4 ---	1-30
A	US,A,5 260 968 (GARDNER ET AL.) 9 November 1993 see abstract; figures 6-8 ---	1-30
A	EP,A,0 595 247 (ATR OPTICAL AND RADIO COMMUNICATIONS RESEARCH) 4 May 1994 see abstract; figures 1,9,10 -----	1-30
<input type="checkbox"/> Further documents are listed in the continuation of box C. <input checked="" type="checkbox"/> Patent family members are listed in annex.		
* Special categories of cited documents : "A" document defining the general state of the art which is not considered to be of particular relevance "E" earlier document but published on or after the international filing date "L" document which may throw doubts on priority claim(s) or which is cited to establish the publication date of another citation or other special reason (as specified) "O" document referring to an oral disclosure, use, exhibition or other means "P" document published prior to the international filing date but later than the priority date claimed "T" later document published after the international filing date or priority date and not in conflict with the application but cited to understand the principle or theory underlying the invention "X" document of particular relevance; the claimed invention cannot be considered novel or cannot be considered to involve an inventive step when the document is taken alone "Y" document of particular relevance; the claimed invention cannot be considered to involve an inventive step when the document is combined with one or more other such documents, such combination being obvious to a person skilled in the art. "&" document member of the same patent family		
Date of the actual completion of the international search  <p align="center">13 September 1996</p>		Date of mailing of the international search report  <p align="center">26.09.96</p>
Name and mailing address of the ISA European Patent Office, P.B. 5818 Patentlaan 2 NL - 2280 HV Rijswijk Tel. (+ 31-70) 340-2040, Tx. 31 651 epo nl, Fax: (+ 31-70) 340-3016		Authorized officer  <p align="center">Angrabeit, F</p>

# INTERNATIONAL SEARCH REPORT

Information on patent family members

International Application No <b>PCT/US 96/08564</b>
--

Patent document cited in search report	Publication date	Patent family member(s)	Publication date
WO-A-9409568	28-04-94	AU-A- 5354294	09-05-94
EP-A-0142293	22-05-85	JP-B- 6100647 JP-A- 60088375 US-A- 4577193	12-12-94 18-05-85 18-03-86
GB-A-2266998	17-11-93	US-A- 5274844 DE-A- 4314739 FR-A- 2691842 IT-B- 1262364 JP-A- 6053727	28-12-93 18-11-93 03-12-93 19-06-96 25-02-94
US-A-5260968	09-11-93	NONE	
EP-A-0595247	04-05-94	JP-A- 6196921 US-A- 5396256	15-07-94 07-03-95

Form PCT/ISA/210 (patent family annex) (July 1992)



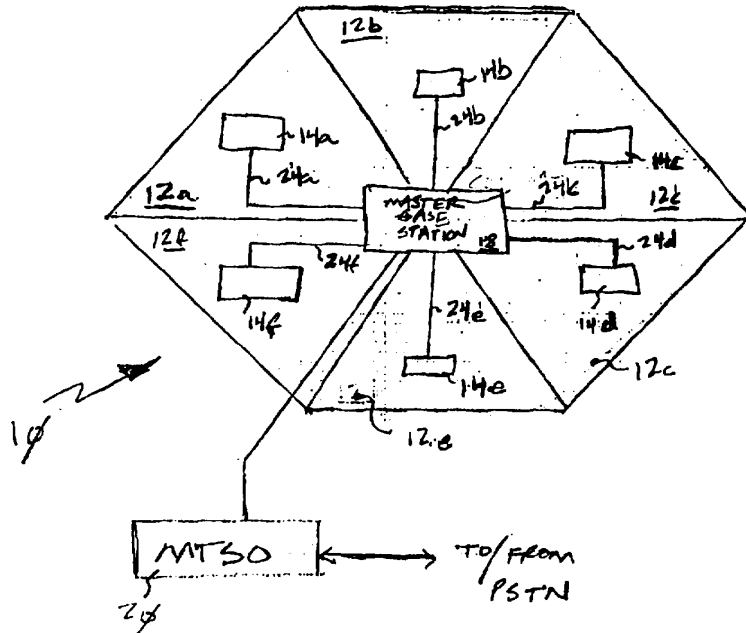
INTERNATIONAL APPLICATION PUBLISHED UNDER THE PATENT COOPERATION TREATY (PCT)

<p>(51) International Patent Classification <sup>6</sup> : H04B 7/26</p>	<p>A1</p>	<p>(11) International Publication Number: <b>WO 97/33388</b> (43) International Publication Date: 12 September 1997 (12.09.97)</p>
<p>(21) International Application Number: PCT/US97/03629 (22) International Filing Date: 7 March 1997 (07.03.97) (30) Priority Data: 08/611,600 8 March 1996 (08.03.96) US (71) Applicant: WATKINS-JOHNSON COMPANY [US/US]; 3333 Hillview Avenue, Palo Alto, CA 94304-1223 (US). (72) Inventors: RALEIGH, Gregory, G.; 539 San Juan Avenue, El Granada, CA 94018 (US). POLLACK, Michael, A.; 20196 Northbrook Square, Cupertino, CA 95014 (US). (74) Agents: TEST, Aldo, J. et al.; Flehr Hohbach Test Albritton &amp; Herbert L.L.P., Suite 3400, 4 Embarcadero Center, San Francisco, CA 94111-4187 (US).</p>	<p>(81) Designated States: AL, AM, AT, AU, AZ, BA, BB, BG, BR, BY, CA, CH, CN, CU, CZ, DE, DK, EE, ES, FI, GB, GE, GH, HU, IL, IS, JP, KE, KG, KP, KR, KZ, LC, LK, LR, LS, LT, LU, LV, MD, MG, MK, MN, MW, MX, NO, NZ, PL, PT, RO, RU, SD, SE, SG, SI, SK, TJ, TM, TR, TT, UA, UG, UZ, VN, YU, ARIPO patent (GH, KE, LS, MW, SD, SZ, UG), Eurasian patent (AM, AZ, BY, KG, KZ, MD, RU, TJ, TM), European patent (AT, BE, CH, DE, DK, ES, FI, FR, GB, GR, IE, IT, LU, MC, NL, PT, SE), OAPI patent (BF, BJ, CF, CG, CI, CM, GA, GN, ML, MR, NE, SN, TD, TG).</p> <p><b>Published</b> <i>With international search report. Before the expiration of the time limit for amending the claims and to be republished in the event of the receipt of amendments.</i></p>	

(54) Title: DISTRIBUTED MICROCELLULAR COMMUNICATIONS SYSTEM

(57) Abstract

A distributed microcellular communications system (Fig. 1B) comprises a plurality of subcells (12a-12f) arranged within a macrocell(s) (10). The system (Fig. 1B) includes remote site station(s) (14a-14f), each transmits and receives information signals over an assigned set of channels within an associated subcell, includes a wideband RF receiver network wherein signals received from mobile units are converted into reverse link digital information signals. Each remote site station also includes a transceiver for transmitting the reverse link signals to a central base station (18) and receiving forward link digital information signals from the central base station (18). The central base station transmits central signals and forward link digital information signals and processes call information contained in the forward and reverse link digital information signals (24a-24f) within particular cellular protocols. Alternatively, the remote site station (14) further includes a channelizer for channel selection and a set of demodulators.



**FOR THE PURPOSES OF INFORMATION ONLY**

Codes used to identify States party to the PCT on the front pages of pamphlets publishing international applications under the PCT.

AM	Armenia	GB	United Kingdom	MW	Malawi
AT	Austria	GE	Georgia	MX	Mexico
AU	Australia	GN	Guinea	NE	Niger
BB	Barbados	GR	Greece	NL	Netherlands
BE	Belgium	HU	Hungary	NO	Norway
BF	Burkina Faso	IE	Ireland	NZ	New Zealand
BG	Bulgaria	IT	Italy	PL	Poland
BJ	Benin	JP	Japan	PT	Portugal
BR	Brazil	KE	Kenya	RO	Romania
BY	Belarus	KG	Kyrgystan	RU	Russian Federation
CA	Canada	KP	Democratic People's Republic of Korea	SD	Sudan
CF	Central African Republic	KR	Republic of Korea	SE	Sweden
CG	Congo	KZ	Kazakhstan	SG	Singapore
CH	Switzerland	LI	Liechtenstein	SI	Slovenia
CI	Côte d'Ivoire	LK	Sri Lanka	SK	Slovakia
CM	Cameroon	LR	Liberia	SN	Senegal
CN	China	LT	Lithuania	SZ	Swaziland
CS	Czechoslovakia	LU	Luxembourg	TD	Chad
CZ	Czech Republic	LV	Latvia	TG	Togo
DE	Germany	MC	Monaco	TJ	Tajikistan
DK	Denmark	MD	Republic of Moldova	TT	Trinidad and Tobago
EE	Estonia	MG	Madagascar	UA	Ukraine
ES	Spain	ML	Mali	UG	Uganda
FI	Finland	MN	Mongolia	US	United States of America
FR	France	MR	Mauritania	UZ	Uzbekistan
GA	Gabon			VN	Viet Nam

## DISTRIBUTED MICROCELLULAR COMMUNICATIONS SYSTEM

### Field

The present invention relates generally to cellular telephone systems. More particularly, the invention relates to a distributed digital communication system incorporated within cellular telephone systems.

5

### Background

Cellular telephone networks facilitate mobile communications within a given geographic area by dividing the area into contiguous regions, or "cells". Each cell includes a base station, located at a "cell-site", which services mobile units within the cell. In a typical cellular network, each cell is assigned a set of transmission frequencies with which to operate. The sets of frequencies assigned to adjacent cells are different, and are typically not repeated except when cells are separated by a sufficiently large "re-use" interval that interference problems are unlikely to occur.

10

Within densely populated metropolitan regions, the overall capacity of a cellular system may be limited by the relatively small set of frequencies assigned to each cell. Furthermore, the coverage of the single cell-site base station within each cell may be compromised by fading and blockage of the transmitted signal energy.

15

One conventional approach to increasing system call carrying capacity involves dividing each original cell within the system into a set of smaller cells. This entails servicing each of the new smaller cells using a conventional base station. Usually, the number of channels at each base station remain unchanged, since the original frequency plan can be applied to a new, scaled-down, cell layout. It follows that since the area covered by each new cell is smaller than the original cell, and since

20

the number of channels available to each base station is the same, the overall system capacity (channels per unit area) is increased. Although this reduction in cell size advantageously increases capacity, an increase in the frequency of calls handed-off between base stations will generally occur. That is, each mobile user may be expected  
5 to cross the boundaries of the smaller cells more frequently than the boundaries between the larger original cells.

The handoff process involves switching the mobile unit from its existing operating frequency to a new frequency allocated to the cell into which the mobile unit is entering. The handoff process is generally coordinated by a mobile telephone  
10 switching office (MTSO) linked to each cell-site base station, and is initiated by the MTSO in response to a request from a base station. A base station requests hand-off when the quality of a communication channel assigned to a given mobile unit drops below a predefined threshold, which typically indicates that the mobile unit is nearing a boundary between cells. The MTSO queries the base stations surrounding the base  
15 station requesting the handoff in order to ascertain which, if any, of the surrounding base stations are capable of establishing communication of suitable quality on a new channel. If the MTSO determines that one of the surrounding base stations is so capable, the MTSO orders the mobile unit to switch to the new channel and passes control to the selected base station. In this way each channel within the cellular system  
20 may be used at a plurality of cell sites simultaneously, and the system is thereby enabled to support a number of users exceeding the number of system channels.

Nonetheless, since the capacity of each MTSO to control handoffs and otherwise process calls is limited, efforts have been made to augment system capacity without subdividing existing cells and deploying additional base station equipment.  
25 For example, in U.S. Pat. No. 4,932,049 to Lee, there is described a cellular telephone system in which a distributed antenna set configuration is deployed within each cell as a means of dividing the cell into a plurality of zones or sectors. Each cell contains a plurality of antenna sets arranged and configured in an effort to limit propagation of signals substantially to one of the plurality of zones or sectors within the boundaries of  
30 the cells. The zones or sectors are substantially less in area than the area of the cell.

In Lee's system all of the antenna sets are coupled to a common set of transmitters and receivers, and a zone switch is used to selectively couple the transmitters and receivers to the antenna units. This selective coupling is coordinated



by a controller located at the cell site, which causes the antenna best able to service a mobile unit on a given channel to be connected to the transmitter/receiver pair associated with the channel. Switching among antenna sets is facilitated by polling the signal strength received at each antenna set from a given mobile unit, and  
5 connecting/disconnecting antenna sets accordingly.

In distributed antenna systems of the type described by Lee, transmission on the frequency assigned to a mobile unit is confined to the zone or sector within which is present the mobile unit. As the mobile unit moves into a new zone or sector within the cell, a "soft" handoff occurs whereby transmission to the mobile unit is switched  
10 from the antenna set within the previous zone to the antenna set within the new zone -during which time mobile unit continues to transmit/receive on the same frequency channel. Frequency handoff (i.e., "hard" handoff) occurs only upon the mobile unit moving to another cell.

The number of zones or sectors into which each cell serviced by a distributed  
15 antenna system may be divided is not limited, but increasing the number of zones does not increase the capacity of the "distributed" cell unless additional channels are assigned to the cell. The assignment of additional channels to a distributed cell is made possible by confining transmission from each antenna set to the surrounding zone, thereby decreasing the frequency re-use interval between neighboring  
20 distributed cells. Nonetheless, distributed antenna systems contemplate only soft hand-offs between the zones of a cell, and hence all of the zones must share all of the channels within the channel set assigned to the cell. It follows that increasing the number of zones within each cell does not increase capacity unless the number of channels assigned to the cell is correspondingly increased.

25 It would thus be desirable to provide a system in which capacity is increased by dividing each cell into a plurality of subcells in a manner not requiring that each subcell use an identical set of channels. The implementation of "intra-cell" hard handoffs between the subcells would make possible such assignment of different channel sets to the subcells. Accordingly, capacity could be increased commensurate  
30 with the extent of subdivision of the cell into subcells.

Cellular systems using distributed antenna arrangements, such as the system proposed by Lee, generally require that the antenna set within each zone captures the entire cellular spectrum. The entire analog cellular spectrum, after perhaps being

shifted to a different analog frequency band, is transmitted over a wideband communications link to the base station. Another exemplary distributed antenna system of this type is described in European Patent Application No. 0 391 597, published on October 10, 1990, submitted by AT&T. In the AT&T system, optical  
5 fiber analog carriers are analog modulated with mobile radio channels throughout the optical fiber network connecting the distributed antenna sites. The entire available set of channels, i.e., the entire allocated cellular band, is transmitted from the base station to the distributed antenna sites, and vice-versa.

Quite obviously, transmission of the entire analog cellular band over a  
10 wideband communications link to each distributed antenna site is inefficient in view of the fact that only a fraction of the band is radiated at each antenna site. Likewise, it is inefficient to transmit the entire received spectrum from each remote antenna site back to the base station, given that only a fraction of the frequency channels received at each remote antenna site carry valid information. A system disposed in which only  
15 frequency channels actually used by a remote antenna site or the like are transmitted to and from the base station could be expected to advantageously reduce the communication link bandwidth required for such information exchange.

Utilization of an analog communication link may also increase the likelihood that weak signals within the analog cellular spectrum received at each antenna may  
20 become lost in the noise of the communications link during propagation to the base station via the analog link. For example, in a cell coverage area of any appreciable radius it is expected that the signals received from mobile units in different parts of the cell may differ in power by as much as 50-75 dB. In the case of optical fiber communication links between the base station and antenna sites, dynamic range is  
25 often limited in practice to less than 40 dB. Accordingly, if two signals separated in power by somewhat more than 40 dB (e.g., by 60 dB) were transmitted from the antenna site to the base station over the optical fiber communication link, the base station would be incapable of recovering the weaker signal. While certain analog communication links realized using media other than optical fiber may afford a larger  
30 dynamic range, the use of analog techniques to transfer a wideband analog spectrum between to and from remote antenna sites is likely to introduce some form of signal distortion.

It would thus be desirable to obviate the need for use of such wideband links by providing a system in which a reduced volume of data is required to pass between the base station and each remote site.

5 Summary

The present invention provides increased capacity within a cellular communication system by deployment of a network of remote site stations within each standard cell (hereinafter "macrocell") of the cellular system, each remote site station comprising one or more sets of antennas and associated transceiver units. This  
10 increased capacity is advantageously achieved without increasing the number of base stations in communication with the cellular system's mobile telephone switching office (MTSO), thereby obviating the need for expensive retrofit or modification of the MTSO when the microcellular system is deployed in a conventional cellular system.

In an exemplary embodiment of the invention, there is provided a distributed  
15 microcellular communication system in which a plurality of subcells are arranged within each macrocell. The distributed microcellular communications system includes one or more remote site stations, each of which has a remote radio transceiver for transmitting and receiving information signals over an assigned set of communications channels within an associated subcell.

20 Each remote site station includes a wideband RF receiver network within which information signals received from mobile units are converted into reverse link digital information signals. Also disposed within each remote site station is a remote communications link transceiver for transmitting the reverse link digital information signals over a communications link to the central base station. The remote  
25 communications link transceiver also receives forward link digital information signals from the central base station.

The central base station includes a central communications link transceiver for receiving the reverse link digital information signals delivered over the communications link, and for transmitting the forward link digital information signals.  
30 The central base station is disposed to process the call information inherent within the forward and reverse link digital information signals in the manner required by the standard protocols of an existing cellular system (e.g., AMPS, GSM), or as required

by other protocols which may be developed in the future. Conventional circuitry is employed to interface the central base station to the MTSO.

In another exemplary embodiment of the present invention, the remote site station further includes a channelizer for selecting a set of the reverse link digital information signals corresponding to the assigned set of communications channels. In the general case the selected set of channels will include far fewer channels than the number of channels in the set assigned to the macrocell in which the remote site station is located. The remote site station may still further include a bank of demodulators for demodulating the set of reverse link digital information signals to produce a set of demodulated reverse link digital information signals. The remote communications link transceiver then transmits the channelized or demodulated reverse link digital information signals to the central base station.

According to another aspect of the invention, a bank of digital modulators are deployed within the transmit section of the remote site station. Each digital modulator is disposed to modulate a carrier signal using one of the forward link digital information signals, with the result that the bank of digital modulators produces a plurality of modulated carrier signals. A bank of digital transmitters are provided for translating the frequency of each of the plurality of modulated carrier signals in order that each said signal occupies an assigned frequency channel within a digitized forward link transmission spectrum. The digitized forward link transmission spectrum is converted to an analog spectrum, upconverted to the RF cellular transmission band, and transmitted from the remote site station.

In accordance with yet another aspect of the invention, reverse link transmissions may be gathered from each mobile unit by a plurality of the remote site stations in order to minimized the likelihood that calls are dropped during the hand-off process. In conventional cellular systems, when a mobile unit approaches a boundary between cells the separation from the base station with which it is communicating approaches a maximum. Consequently, the forward and reverse communication links to and from the mobile unit tend to deteriorate due to increased path loss. In order to prevent deterioration of the communication links to such extent that the call is dropped, it becomes necessary for the cellular system to quickly decide whether a hand-off should occur. The decision of when to undertake the hand-off process is further complicated by the presence of slow fading in the communications channel.

Such slow fading can corrupt hand-off decisions by affecting the mobile unit signal strength received at hand-off candidate base stations during the polling process.

The present invention overcomes many of the difficulties associated with hard hand-off between remote site stations by monitoring reverse link transmission from a given mobile unit at a plurality of surrounding base stations. Since this allows the strongest signals to be selected for processing, degradation of the quality of the reverse link is minimized when the mobile unit becomes proximate a cell boundary. Similarly, the channel statistics accumulated by the plurality of remote site stations monitoring reverse link transmission from a given mobile unit may be of assistance in selecting the base station(s) in the best position to effectively transmit on the forward link to the mobile unit. By employing macrodiversity techniques to monitor the communication links between a plurality of base stations and a given mobile unit, the present invention facilitates improved communication quality and well-informed hand-off decisions.

The architecture of the distributed microcellular communications system of the invention has also been designed to enable diversity reception at each remote site station. By collecting reverse link signals using two or more antennas deployed at a remote antenna site, Rayleigh (i.e., fast) fading of the communication channel may be mitigated. The signals received from the two or more remote site station antennas are combined at the remote site station, and the resultant diversity signal transmitted back to the central site station over the communications link. This use of diversity combination techniques at the remote site station allows the communication link to the central base station to be of a bandwidth no greater than that required to carry the information to and from a single remote site station antenna element. In contrast, conventional distributed antenna systems typically require that the reverse link signals received by multiple remote antennas each be conveyed to a central base station over the same communication link. Hence, the complexity and expense of conventional systems is increased due to the need for deployment of a wideband communication link between the base station and the multiple remote antennas.

Brief Description of the Drawings

Additional objects and features of the invention will be more readily apparent from the following detailed description and appended claims when taken in conjunction with the drawings, in which:

5           Figure 1A is an illustrative representation of a plurality of standard hexagonal macrocells.

          Figure 1B is an illustrative representation of a standard hexagonal macrocell which has been partitioned into a set of six subcells.

10           Figure 1C is an illustrative representation of a standard hexagonal macrocell which has been partitioned into a set of six subcells.

          Figure 2 provides a block diagrammatic representation of a central base station linked to a remote site station disposed within a subcell.

15           Figure 3 shows a block diagram of an exemplary digital filter network suitable for incorporation within the channelizers deployed in the central base station and/or remote site stations.

          Figure 4 provides a block diagrammatic representation of an embodiment of the communication system of the invention in which a channelizing function is performed at each remote site station.

20           Figure 5 depicts the manner in which a remote site station may be configured for diversity reception by including therein more than one separate receive path.

          Figure 6 is a block diagram of a distributed communication system of the invention in which both channelizing and modulation/demodulation functions are performed at each remote site station.

25           Figure 7 is a block diagram of a distributed communication system which is similar to the system of Figure 6, but which is different in that a beamformer function is performed at the remote site station.

          Figure 8 is a flowchart representative of an exemplary manner in which calls are processed in accordance with the invention.

30   Detailed Description

The present invention is designed to be deployed either (i) within an existing cellular system as a means of economically increasing capacity, or (ii) as an independent high-capacity cellular system. The present invention provides a

distributed microcellular communications system disposed to operate transparently with respect to the mobile telephone switching office (MTSO) of the existing cellular system. That is, the distributed microcellular system is configured so as to be capable of deployment in the absence of significant modification to the existing cellular  
5 system, and is designed to allow increased capacity to be achieved without requiring that enhancements be made to the processing resources elsewhere within the system. As is described below, the inventive microcellular system contemplates that each cell serviced by an existing cellular base station (hereinafter referred to as a "macrocell") be partitioned into a plurality of subcells.

10 Referring to Figure 1A, there is shown a set of four contiguous macrocells la-ld of a cellular communication system of the present invention. Each macrocell la-ld is partitioned into nine subcells, each of which is assigned one of three channel sets {A,B,C}. In particular, three contiguous subcells within each macrocell la-l are assigned to operate using channel set A, three subcells are assigned for operation upon  
15 channel set B, and the remaining three subcells operate upon channel set C. As is described hereinafter, hard hand-off techniques are used to transfer calls between the subcells as a means of facilitating utilization of the three different channel sets {A,B,C} within each subcell. This advantageously allows each macrocell to be partitioned into a large number of subcells while maintaining a high degree of  
20 frequency re-use.

Referring now to Figure 1B, an illustrative representation is provided of a standard hexagonal macrocell 10 which has been partitioned into a set of six subcells 12a-12f. Since each remote site station 14a-14f is of substantially identical design, only remote site station 14a will be described in greater detail. The six subcells 12a-  
25 12f are respectively serviced by a set of six remote site stations 14a-14f, each of which are coupled to a central base station 18. Except to the extent otherwise indicated, central base station 18 comprises a conventional cellular base station disposed to be controlled by an MTSO 20. Base station 18 is linked to the MTSO 20 through a conventional interface line 22 (e.g., a T1 line, line of sight microwave link, or optical  
30 fiber). Similarly, the MTSO 20 is interfaced in the usual way with the public switched telephone network (PSTN).

It should be understood that the number of subcells into which each macrocell is divided will be dependent upon the desired overall system capacity. In this regard

Figure 1C depicts a macrocell 10' which has been partitioned into a set of four subcells 12a'-12d', in which are respectively located remote site stations 14a'-14d'. In Figure 1C, primed reference numerals are used to identify system elements performing substantially similar functions as those elements identified with corresponding reference numerals in Figure 1B. In accordance with the invention, increased capacity to service mobile users is achieved through deployment of a network of remote site stations 14a-14f (Figure 1B) within each macrocell. The increased capacity afforded by the present invention arises from a reduction in the frequency re-use interval between macrocells. By employing hard hand-offs between the groups of subcells within each macrocell operative using different channel sets (see Figure 1A), any desired frequency re-use interval can be achieved.

The remote site stations 14a-14f collectively provide radio coverage to the geographic area encompassed by the macrocell 10, and are respectively in communication with the central base station 18 through communication links 24a-24f. The communication links 24a-24f may be realized using a variety of interconnection technologies (e.g., coaxial cable, optical fiber, or line-of-sight optical or microwave links). As is described in further detail below, in alternate embodiments of the invention the remote site stations 14a-14f are configured to perform signal processing functions of varying degrees of complexity. Accordingly, the nature and quantity of the information carried by the communication links 24a-24f between the central base station 18 and the remote site stations 14a-14f will be dependent upon the particular signal processing operations executed at the remote site stations 14a-14f. Although in the exemplary embodiment of Figure 1B the central base station 18 does not provide radio coverage to a subcell associated therewith, it is understood that the base station may readily be configured with a radio transceiver capable of radio communication with mobile units (not shown) within a surrounding subcell. That is, in alternate embodiments the central base station 18 may be implemented to function as a remote site station while continuing to provide central control to the other remote site stations.

In a first preferred embodiment, each remote site station 14a-14f is equipped with a wideband transceiver network operative to frequency translate cellular band signals to and from digitized intermediate frequency (IF) representations of the cellular band signals. This results in digitized, baseband representations of the cellular "forward" and "reverse" links being carried by the communication links 24a-24f.



Specifically, the digitized forward link signals are transmitted from the central base station 18 to the remote site stations 14a-14f via the communication links 24a-24f, and the digitized reverse link signals propagate in the opposite direction.

In a second preferred embodiment, each remote site station 14a-14f is provided  
5 with a channelizer designed to select only certain of the digitized reverse link signals among the complete set of frequency channels within the cellular band. The particular set of channels selected by the channelizer is specified by the central base station, and includes all channels currently in use within the subcell in which the channelizer is located. In addition, the channelizer may select channels in use in other subcells in  
10 order to support other processing or monitoring functions within the central base station. The channel signals selected by the multiplexer are multiplexed into a frequency band smaller than that occupied by the entire digitized reverse link cellular frequency band, and the multiplexed signals transmitted over the communication links 24a-24f to the central base station 18. On the forward link, the central base station 18  
15 multiplexes the signals for the selected channels onto the communication links 24a-24f. Each remote site station 14a-14f demultiplexes the signals sent by the central base station, and passes the demultiplexed signals through a wideband upconversion network for transmission from the remote site station's antenna.

In a third preferred embodiment, each remote site station 14a-14f is not only  
20 provided with a channelizer, but also includes a set of demodulators for demodulating each selected reverse link signal to a "digital voice" (e.g., DS0) signal. This allows the digital voice signals to be multiplexed into a narrow frequency band, thereby further reducing the requisite bandwidth of the communication links 24a-24f from each remote site station to the central base station 18. On the forward link, the central base  
25 station 18 provides to each remote site station 14a-14f the set of digital voice signals to be broadcast over the channels assigned to the remote site station. After demultiplexing the digital voice signals provided thereto, each remote site station uses the demultiplexed digital voice signals to modulate baseband carrier signals. The modulated baseband carrier signals are then passed through a wideband upconversion  
30 network, and transmitted by the remote site station's antenna.

In order to facilitate proper system operation, certain control information is exchanged between the remote site stations and the central base station. This control information is multiplexed with the digital voice signals on the communication links

24a-24f. For example, the central base station may multiplex, with the forward link digital voice signals, control information informing a remote site station which RF transmit frequency corresponds to each digital voice signal sent to the remote site station. This facilitates dynamic allocation of frequencies among the subcells  
5 comprising a given macrocell, and may be employed to reduce the likelihood of co-channel interference between adjacent subcells. Other features and advantages of the present invention are discussed below in connection with the detailed description provided for each preferred embodiment.

The present invention is disposed to be implemented within any of a number of  
10 different types of cellular telephone systems. These include existing analog Advanced Mobile Phone Service (AMPS) cellular networks, as well as various digital multiple access systems: frequency division multiple access (FDMA), code division multiple access (CDMA), and time division multiple access (TDMA). Although the present invention is capable of being incorporated within these and other cellular telephone  
15 systems, the exemplary embodiment described hereinafter is directed toward an AMPS implementation consisting of frequency modulated (FM) channels at kHz spacings. Those skilled in the art aware that each AMPS frequency channel can be subdivided into three TDMA digital channels, or alternately that a combination of AMPS and TDMA channels could be supported.

20 Turning now to Figure 2, a block diagrammatic representation is provided of one embodiment of the central base station 18 and remote site station 14a. Again, each remote site station 14a-14f is assumed to be of substantially identical design, and hence the configuration of only one remote site station 14a is depicted in detail.

The remote site station 14a is seen to include TX and RX antennas 32 and 34  
25 for transmitting and receiving signals (e.g., within the AMPS forward and reverse channel spectra) to and from mobile units (not shown). Those skilled in the art will realized that the TX and RX antennas 32 and 34 could be replaced with a single antenna and diplexer. The signals received by RX antenna 34 are applied to frequency downconverter (DNX) 36. The DNX 36 is operative to translate the reverse channel  
30 spectrum of the received signals to a lower frequency range. For example, in an exemplary implementation an AMPS system A reverse channel spectrum from 825-835 MHz containing 333 channels is translated by DNX 36 to the 0.5-10.5 MHz band.

The downconverted reverse channel spectrum is sampled by analog to digital converter (ADC) 40 at a sampling rate of at least twice the highest frequency contained within the output of the DNX 36. In the exemplary AMPS System A implementation, this corresponds to a theoretical minimum sampling rate 21 MHz, and in practice 25 MHz might be used. The digital samples (e.g., 12-bits per sample) produced by ADC 40 are provided in the form of a stream of digital words over a parallel data bus to a reverse channel communication link transmitter 44.

The reverse channel communication link transmitter 44 includes a parallel to serial converter operative to convert the 12-bit samples received from the ADC 40 to a serial bit stream. In the exemplary embodiment the serial bit stream from the serial to parallel converter is provided to a reverse link line 48a of communications link 24a. When the reverse link line 48a is realized as an optical fiber, the reverse channel communication link transmitter 44 includes a laser transmitter disposed to be modulated by the data from the ADC 40. The modulated optical output from the laser transmitter is applied to the reverse link line 48a for transmission to a first reverse channel communication link receiver 52a within the central base station 18. The central base station 18 further includes reverse channel communication link receivers 52b-52f for receiving similar modulated optical signals from the remote site stations 14b-14f, respectively.

The remote site station further includes a forward channel communication link receiver 54 operative to receive a forward channel digital data stream from a forward link line 56a of communication link 24a. When the forward link line 56a is realized as an optical fiber, the receiver 54 comprises an electro-optical detection network such as a photo-diode detector. Likewise, a first forward channel communication link transmitter 58a comprised of a laser transmitter may be used to transmit the forward channel digital data stream over the forward link line 56a. Other forward channel communication link transmitters 58b-58f likewise transmit forward channel digital data streams to the remote site stations 14b-14f, respectively.

It is understood that the forward and reverse link lines 48a and 56a of communication link 24a may comprise transmission media other than optical fibers (e.g., coaxial cable), or may be replaced by microwave or other point-to-point links. Accordingly, the specific implementation of the forward and reverse channel

communication link transmitters/receivers will be dependent upon the medium of the communications link 24a.

Within the remote site station 14a, the communication link receiver 54 converts the serial data stream received over the communications link 24a to 12-bit digital data samples, and relays the forward channel digital data stream to a digital to analog converter (DAC) 60. In an exemplary embodiment, the forward channel digital data stream comprises a digitized, intermediate frequency (e.g., 0.5 MHz to 10.5 MHz) replica of the forward channel spectrum to be transmitted by the TX antenna 32. The corresponding intermediate frequency analog waveform produced by the DAC 60 is applied to a wideband frequency upconverter (UPX) 64, and is therein translated to the forward channel spectrum of a particular cellular system. For the specific case of AMPS System A, the forward channel spectrum transmitted by TX antenna 32 extends from 870 MHz to 880 MHz.

Referring again to Figure 2, the digitized frequency-downconverted replica of the reverse channel spectrum is provided at an exemplary bit rate of 300 Mbps (12 Msps x 12 bits/sample) by the communication link receiver 52a to a first base station channelizer 66a. The central base station 18 further includes channelizers 66b-66f similarly coupled to the communication link receivers 52b-52f, respectively. The channelizer 66a functions to extract the individual signals corresponding to each frequency channel present within the digitized, frequency-downconverted reverse link channel spectrum provided by the communication link receiver 52a. The extracted frequency channels are divided into separate, parallel data streams, each of which possesses a signal bandwidth consistent with the channel spacing of a particular cellular system (e.g., 30 kHz for AMPS). The sample rate of each extracted channel is sufficiently high to satisfy the Nyquist criterion (e.g., 260 ksps for a 30 kHz AMPS channel), but will typically be appreciably less than the sample rate into the first base station channelizer 66a (e.g., 25 Msps).

The first base station channelizer 66a may be programmed by the base station controller 70 to extract a specific set of desired channels present within the digitized spectrum provided by the communications link receiver 52a. For example, in a specific implementation a frequency re-use factor of four is employed between macrocells, thereby resulting in approximately one-fourth of the available frequency channels being assigned to each macrocell (e.g., 78 channels per macrocell).

Assuming each macrocell to be divided into four subcells, it follows that each subcell is allocated nineteen voice channels and a shared control channel. This results in each base station channelizer 66 being programmed to extract the twenty channels assigned to the subcell from the digitized reverse-channel spectrum received from the associated remote site station.

It is observed that in the specific embodiment of Figure 2, the RX beamformer 90 associated with a given subcell is provided with information from the channelizers associated with subcells adjacent to the given subcell. This requires that each channelizer extract from the reverse-channel spectrum provided thereto not only the channels assigned to its associated subcell, but also the channels assigned to the subcells adjacent its associated subcell. In alternate embodiments, each channelizer may be programmed to extract all of the channels assigned to a particular macrocell.

Each channelizer 66a-66f includes a separate digital filter network for extracting, from the high-speed (e.g., 25 Msps) data stream provided thereto, each of the channels specified by the base station controller 20. The passband of each digital filter network is commensurate with the channel spacing of the reverse link channels (e.g., 30 kHz), and spans one of the frequency channels within the frequency-downconverted reverse link spectrum (e.g., 0.5-10.5 MHz).

Turning now to Figure 3, a block diagram is provided of an exemplary digital filter network 72 suitable for incorporation within the channelizers 66a-66f. The filter network includes a digital bandpass filter 74 of 30 kHz bandwidth, preferably realized as a finite impulse response (FIR) filter. The filtered output from the digital bandpass filter 74 is then applied to a multiplier 76, within which it is frequency translated to digital baseband via multiplication with a complex sinusoid. The complex sinusoid, which is of a frequency equal to the center frequency of the bandpass filter 74, is generated by a numerically-controlled oscillator 78. As is indicated by Figure 3, a decimator 80 is operative to reduce the exemplary 25 Msps rate of the baseband output of the multiplier 76. The decimator 80 reduces this rate by a predetermined factor, the value (e.g., 300) of which is selected to prevent aliasing by causing the resultant output sample rate (e.g., 83.3 KHz) to become equal to at least twice the exemplary 30 kHz channel bandwidth.

Referring again to Figure 2, a set of N receive (RX) beamformers are each disposed to receive the channelized data stream produced by each channelizer 66a-66f

corresponding to one of N reverse-link voice channels. Additionally, RX beamformer 92 is provided the data stream from each channelizer 66a-66f corresponding to an RECC channel, which is a time-division multiplexed control channel. Each RX beamformer 90 is designed to enhance signal quality by using various techniques to

5 weight and combine the data streams from different remote site stations corresponding to the same reverse link channel. For example, in a simplified implementation only the data stream of the highest signal quality is weighted by a factor of "1", and every other stream is nulled by weighting with a factor of "0". When so configured, the RX beamformer essentially operates to implement "selection diversity" combining

10 selecting only a single reverse-link data stream.

Within each RX beamformer 90 there exist a plurality of signal quality determination circuits, each of which measures the quality of the reverse-link data streams received from one of the channelizers 66a-66f. The results of the signal quality measurements determine the manner in which the streams of the same

15 frequency from the channelizers 66a-66f are weighted by each RX beamformer 90. In the exemplary embodiment the stream of highest quality is weighted by a factor of "1", and the remaining streams of the same frequency by a factor "0". This results in the combination of the weighted reverse-link data streams output by each beamformer 90 comprising the single stream from the subcell best suited to sustain communication

20 with a given mobile unit.

Received signal quality may be determined based upon, for example, total signal power received within the frequency channel in question. However, because the signal power measurement cannot distinguish between power from the desired user and power from interfering users, this technique is best suited for systems within

25 which the expected interfering signal power is expected to be low within all subcells of a macrocell. Other techniques for determining received signal quality can be used as well, including those which rely upon calculation of the SINR at each of the inputs to the beamformer.

The RX beamformers 90 may also be designed such that more than a single

30 reverse-link data stream is assigned a non-zero weighting factor. This results in the output of each RX beamformer comprising a weighted combination of the reverse-link data streams provided thereto. In this implementation the signal weighting and combining performed by the RX beamformers 90 may be viewed as constituting

adaptive receive antenna beamforming among the remote site stations. Accordingly, receive beamforming techniques designed for use with co-located antenna arrays may be utilized in the present embodiment to optimize signal reception by the set of remote site stations within a given macrocell. As a specific example, for systems including  
5 slow-moving mobile units it is expected that use of a "constant modulus" adaptive beamforming algorithm within the RX beamformers 80 will enhance signal reception in a multipath signal environment.

It has been found that both fast (Rayleigh) fading, as well as slow (log-normal) fading, occurring at remote sites separated by relatively large distances (e.g., > 300  
10 yards) tends to be largely uncorrelated. Thus, combining signals from remote sites in the RX beamformers 90 is expected to be able to diminish the severity of both fast and slow fading. In the preferred embodiment each RX beamformer 90 adapts its signal weighting at a rate which is responsive to fast fading signal components. This may advantageously reduce or even eliminate the need for employment of microdiversity  
15 reception techniques at each remote site station as a means of mitigating fast fading.

The inclusion of the RX beamformers 90 within the central base station 18 also aids the base station controller 70 in determining when to request that the MTSO initiate handoff of a mobile unit to another macrocell. By monitoring the signal quality (e.g., average received power level, signal-to-noise ratio, fading depth and/or duration,  
20 etc.) of the composite frequency modulated carrier from one RX beamformer 90, the base station controller 70 is able to determine whether the remote site stations are collectively able to produce a useable signal on the frequency channel corresponding to that beamformer. This is so because each remote site station is provided the opportunity to contribute to the composite frequency modulated carrier produced by  
25 each RX beamformer 90. It follows that if the quality of the composite signal drops below a minimum quality threshold for a given period of time, the base station controller 70 may conclude that the remote site stations are unable to, either singly or in combination, produce acceptable signal quality using the signal energy received from a given mobile unit. Hence, there is no need to separately "poll" each remote site  
30 station prior to requesting the MTSO to initiate handoff of the mobile unit to another macrocell.

The composite frequency modulated carriers from the set of RX beamformers 90 and 92 are provided to a corresponding set of reverse-link demodulators 96 and 97,

respectively. Each demodulator 96 extracts a digitized waveform, similar in format to a DSO voice signal, from the composite frequency modulated carrier provided thereto. In an exemplary AMPS embodiment, the demodulated digital waveform produced by each demodulator 96 is comprised of an approximately 8 kHz stream of 8-bit samples.

5 The 8-bit samples primarily comprise digitized voice information but, during periods in which signaling is taking place over the reverse voice channel, the 8-bit samples will also comprise digital signal information. In the exemplary embodiment each reverse voice channel digital message is preceded by a predefined (e.g., 37-bit) dotting sequence, thereby allowing each demodulator 96 to discriminate between voice

10 channel data and digital messages. Digital messages are provided to the controller 70. The demodulated digital waveforms from the demodulator 96 are multiplexed by a T1 multiplexer 100 into a serial bit stream, which is forwarded to the MTSO 20 over a communications link to the MTSO from the base station. The demodulator 97 similarly demodulates the output produced by RX beamformer 92, and provides the

15 resultant baseband control waveform (e.g., RECC) to a control channel transceiver 98.

The control channel transceiver 98 is disposed to process the forward (FOCC) and reverse (RECC) control channels in accordance with the applicable cellular standard. In particular, the control channel transceiver 98 interprets RECC messages received from remote sites 14a-14f during the processing of calls in the manner

20 contemplated by the applicable cellular standard. The control channel transceiver 98 also generates control messages transmitted by the remote sites 14a-14f over the FOCC.

Referring again to Figure 2, the signal transmission path within the central base station 18 originates at interface demultiplexer 104. The demultiplexer 104

25 separates the input serial data stream received from the input line 22 into payload (e.g., voice traffic), and control data streams. The control data stream is provided to the controller 70, and the channelized payload data streams are provided to a set of forward link modulators 108. In addition, forward link control channel data is furnished by the control channel transceiver 98 to a control channel modulator 110.

30 Since only digital information is typically transmitted over the control channel, the control channel modulator 110 will generally be adapted to perform only digital modulation.



The forward link modulators 108 are disposed to operate in one of two modes. In particular, the modulators 108 modulate a baseband carrier signal using either: (i) voice information from demultiplexer 104, or (ii) control information from controller 70. In an exemplary embodiment the modulators 108 utilize well-known digital signal processing (DSP) techniques to perform this frequency modulation. During the brief periods of message data transmission over a voice channel (e.g., within an AMPS system) is required, the modulation format will temporarily change to binary frequency-shift keyed (FSK) from the nominal FM modulation format. Since each modulator 108 produces an output having a bandwidth approximately equivalent to a single forward link channel (e.g., 30 kHz within AMPS), the sample rate at the output of each modulator 108 is selected to be at least twice the channel bandwidth in order to prevent aliasing (e.g., at least 83.3 ksps).

As is indicated by Figure 2, the modulated output from each modulator 108 and 110 is provided to a corresponding forward link digital transmitter 114. Each digital transmitter 114 upconverts the frequency of one of the modulated sample streams to a unique frequency slot within a predetermined intermediate frequency (IF) band. In an exemplary embodiment, each digital transmitter 114 produces an IF output at a unique frequency within an IF band extending from 0.5 to 10.5 MHz. Since in an exemplary embodiment the sample rate into each digital transmitter 114 is approximately 83.3 ksps, interpolation is required to increase the sample rate to at least 21 MHz in order to avoid aliasing of the IF outputs, with 25 MHz being chosen for the exemplary embodiment. As discussed below, within the remote site station 14a these IF signals are converted to analog signals and further upconverted to signals within the forward link cellular band. Accordingly, the base station controller 70 is able to allocate the modulated output of each modulator 108 and 110 to a desired channel by specifying the IF frequency slots (e.g., between 0.5 and 10.5 MHz) into which the modulated outputs are to be placed by the digital transmitters 114.

In a simplified embodiment, each TX beamformer 118 functions to select only certain IF frequencies for transmission to each remote site station. That is, the selected frequencies are weighted with a "1", and frequencies not selected for transmission to a given remote site station are weighted with a "0". However, in alternate embodiments the TX beamformers may be configured to cause a given frequency to be transmitted by more than one remote site station. This situation may arise when, for example, the

mobile unit assigned to a particular frequency is proximate the boundary between a pair of subcells.

Each TX beamformer 118 provides a 12-bit wide stream of data at an exemplary 25 MHz rate to one of the forward channel communication link transmitters 58a-58f. Each transmitter 58a-58f is coupled to a corresponding remote site station 14a-14f through a forward link line 56a-56f. When the forward link lines 56a-56f are realized as optical fibers, the forward channel communication link transmitters 58a-58f include laser transmitters disposed to be modulated by a serial data stream derived from the 12-bit wide data streams from the TX beamformers 118. The modulated optical output from each laser transmitter is applied to the forward link lines 56a-56f for transmission to the forward channel communication link receivers respectively disposed within the remote site stations 14a-14f.

The base station controller 70 is disposed to regulate communication with the MTSO 20, as well as to oversee operation of each remote site station 14 within the macrocell 10. In this regard the base station controller 70 is designed to "appear" to the MTSO 20 as would the controller of a standard macrocell base station, thereby obviating the need for any significant modification of data processing resources within the MTSO 20. Although appearing in the usual way to the MTSO 20, the base station controller 70 is capable of performing functions (e.g., frequency channel hand-offs between mobile units) heretofore not executed within macrocell base stations. That is, the base station controller 70 is designed to effect a variety of control functions in a manner transparent to the MTSO 20. As a consequence, system capacity may be increased without undertaking expensive augmentation or modification of existing MTSO signal processing resources.

As mentioned above, one function performed by the base station controller 70 relates to the monitoring of the quality of the composite frequency modulated carrier from one or more RX beamformers 90. By monitoring this parameter, the base station controller 70 is able to determine whether the remote site stations are collectively able to produce a useable signal. Hence, the base station controller is able to decide when to request that the MTSO initiate handoff of the mobile unit to another macrocell based on the signal quality produced by the RX beamformers 90.

The base station controller 70 is also configured to orchestrate call hand-offs between the remote site stations 14a-14f so that as the mobile unit moves throughout

the macrocell 10 the most suitable remote site station transmits to mobile unit The determination as to which of the remote site stations 14a-14f is the most suitable for transmitting to the mobile unit is made by monitoring the quality of the signal received from the mobile unit at the remote site stations. This function is integrated within each  
5 RX beamformer 90, 92 which assesses the quality of the signal on each of its inputs in order to determine the weighting to be applied to those inputs. This information produced in the RX beamformers can be used to determine the weights which are applied within the TX beamformers.

For example, if one of the RX beamformers determines that remote site station  
10 14a is receiving a very strong signal from the mobile unit on its corresponding frequency channel, then the RX beamformer will weight the input from channelizer 66a more heavily than the input from the other channelizers. Knowing that remote site station 14a is receiving a better quality signal from the mobile unit than any of the other remote site stations the controlled chooses to transmit to that mobile unit from  
15 remote site station 14a. The TX beamformer 118 connected to communications link interface 58a applies a weight of "1" to its input from the digital transmitter 114 which corresponds the frequency channel in use by the mobile unit. The other TX beamformers weight their inputs from that particular digital transmitter with a "0", effectively preventing transmission from remote site stations 14b-14f.

20 It is expected that the remote site station 14a-14f identified by the base station controller 70 to be best able of communicating with a given mobile unit may occasionally not be in communication with the mobile unit. Moreover, the identified remote site station 14a-14f may not be currently assigned for operation upon the frequency channel to which the mobile unit is tuned according to the network  
25 frequency planning scheme. Under these circumstances, the base station controller 70 may initiate a "hard" hand-off procedure during which the mobile unit is commanded by the remote site station 14a-14f currently in communication therewith to tune to a new frequency channel assigned to the new remote site station 14a-14f. In the case of a TDMA system, the mobile unit is also assigned to given time slot on the new  
30 frequency channel.

In the exemplary embodiment these hand-off instructions are provided to the mobile unit via a FOVC data message. The base station controller 70 then (i) commands the appropriate digital transmitter to become tuned to a new frequency, (ii)

adjusts one or more TX beamformers as necessary to initiate change transmission from the remote site stations involved in the hand-off, and (iii) informs the MTSO at a convenient later time that a hard hand-off has occurred. It is observed that hard hand-offs between remote site stations 14a-14f are effected in a manner which is transparent to the MTSO. In this way cell capacity may be advantageously increased by deploying additional remote site stations in a manner which does not strain existing processing capability of the MTSO.

As is indicated by Figure 2, the control channel transceiver 98 receives demodulated reverse control channel data (RECC) from the demodulator 96. This information is forwarded to the base station controller 70, which interprets the RECC data in order to process calls in accordance with standard protocols. In addition, the base station controller 70 also generates the control messages transmitted over each forward control channel (FOCC) by the remote site stations 14a-14f. In the exemplary embodiment each remote site station 14a-14f simultaneously transmits identical FOCC information, thereby ensuring that the FOCC information is uniformly disseminated throughout the entire macrocell 10.

Referring to Figure 4, a block diagrammatic representation is provided of an embodiment of the communication system of the invention in which a channelizing function is performed at the remote site station. In Figures 2 and 4, like reference numerals are used to identify those processing elements performing substantially similar functions. Within the remote site station 14a, signals received by the RX antenna 34 are applied to frequency downconverter (DNX) 36 and translated to a lower frequency range. The downconverted reverse channel spectrum is sampled by analog to digital converter (ADC) 40 at a sampling rate of at least twice the highest frequency produced by the DNX 36.

The sampled, frequency-downconverted reverse channel spectrum produced by the ADC 40 is provided to a remote site channelizer 120. The remote site channelizer 120 functions to extract the digitized channel information corresponding to receive channels present within the reverse link cellular frequency spectrum. The extracted channel information is divided into separate, parallel data streams, each of which occupies a bandwidth consistent with the channel spacing of a particular cellular system (e.g., 30 kHz for AMPS). The parallel data streams corresponding to the channels extracted by the channelizer 120 are combined by a remote site multiplexer

128 into a serial data stream, which is provided to the reverse channel communication link transmitter 44.

In the exemplary embodiment the remote site channelizer 120 is instructed by the remote site controller 124 as to which channels are to be extracted from the received reverse channel spectrum. The channels specified by the remote site controller 124 for extraction by the channelizer 120 will nearly always include at least those channels assigned to mobile units in the subcell of the remote site station. Additionally, in order to facilitate RX beamforming at the central base station the extracted channels may also comprise those assigned to mobile units in surrounding subcells. Finally, the extracted channels may also correspond to those under evaluation for hand-off either to another macrocell, or to the remote site station within an adjacent subcell.

As is shown in Figure 5, the remote site station 14a may be configured for diversity reception by including therein one or more separate receive paths. In particular, the remote site station 14a may optionally include a second RX antenna 34a, a second DNX 36a, a second ADC 40a and a second remote site channelizer 120a. The outputs of the remote site channelizers 120 and 120a are combined using conventional techniques within a diversity combiner 130, and the resultant set of parallel data streams provided to the multiplexer 128. The remote site configuration of Figure 5 enables "microdiversity" reception over the subcell covered by the remote site station 14a without the necessity of separate transmission, to the central base station, of the reverse link spectrum received by different remote site antennas.

While Figure 5 shows a remote site implementation capable of performing conventional microdiversity using a pair a receive antennas, the concept can be extended to the combination of signals captured by an antenna array with 3 or more antennas. For each additional antenna, by using sophisticated signal processing techniques, a improvement in received signal quality can be realized. The advantage of implementing remote site antenna combining therefore becomes even more dramatic since, if the antenna combining were to be performed at a central site, that would necessitate relaying M (where M is the number of remote site receive antennas) copies of the reverse link spectrum to the central site over the communications link connecting the central site to the remote site station.

Referring again to Figure 4, a remote site station demultiplexer 134 is disposed to divide the serial TDM data stream produced by the forward communication link receiver 54 into a set of parallel data streams provided to a bank of digital transmitters 114. Each digital transmitter 114 is assigned to one of the frequency channels in use by the remote site station 14a, and the output of each is combined within a digital adder 136 and forwarded to the DAC 60. Distribution of frequency channels among the digital transmitters 114 is effected by the digital transmitter bank 114 pursuant to instructions from the remote site controller 124. The demultiplexer routes channel frequency information, contained within a predetermined time slot on the data stream produced by the forward channel communications link, to the remote site controller 124. The remote site controller then sets each digital transmitter in accordance with the received channel frequency information.

In alternate implementations, information may be transmitted asynchronously over the communication link 56a in a packet format rather than in a time-division multiplexed mode. In this case the data stream from the remote forward channel communication link receiver 54 would be distributed by the demultiplexer 134 on the basis of packet header information or the like, rather than on the basis of time slot assignment.

Directing attention now to the implementation of the central base station 18 of Figure 4, the serial data stream produced by each reverse channel communication link receiver 52a is provided to a different reverse channel demultiplexer 140a-140f. Each demultiplexer 140a-140f demultiplexes the TDM serial stream comprised of the channels assigned to, or monitored by, a corresponding remote site station 14a-14f. The parallel data streams from each demultiplexer 140a-140f are then routed to a bank of RX beamformers 144, each of which is associated with a single receive frequency channel. That is, the data stream from each demultiplexer 140a-140f corresponding to the same frequency receive channel is provided to the same one of the RX beamformers 144.

Each RX beamformer 144 may be designed to use any of a number of available beamforming techniques to weight and combine the data streams provided thereto by the demultiplexers 140a-140f. For example, in a preferred embodiment the complex value of a weighting factor applied to each incident data stream is varied in response

to changes in the propagation environment for the frequency channel corresponding to the data stream.

In a "selection diversity" approach to beamforming, the output of each RX beamformer 144 is simply equivalent to the one of its inputs having the highest signal quality. That is, the highest quality input is weighted by a factor of "1", and the remaining inputs weighted by a factor of "0". Alternately, within each RX beamformer inputs provided thereto are weighted commensurately with signal quality and combined. In this implementation, the inputs to the Rx beamformer are adjusted in phase so as to add constructively upon such combination.

The utilization of the RX beamformer 144, is expected to facilitate the process of determining when the controller 70 should issue a hand-off request to the MTSO 20. Specifically, once the signal quality associated with the output of a particular RX beamformer 144 falls below a minimum quality threshold for some predefined interval, the controller 70 initiates the hand-off process with the MTSO 20. Since each RX beamformer 144 is provided with input from each remote site station 14a-14f disposed to receive the frequency channel of interest, there exists no need to separately "poll" each remote site station with respect to signal quality prior to proceeding with the hand-off determination process.

As is indicated by Figure 4, the central base station 18 includes a set of TX beamformers 150a-150f respectively associated with the remote site stations 14a-14f. Each TX beamformer 150a-150f receives modulated baseband signal inputs from N of the modulators 110, where N is the number of frequency channels currently being used by the associated remote site station 14a-14f. Each TX beamformer 150a-150f is also provided with an input corresponding to forward control channel (FOCC) by the control channel transceiver 98. In an exemplary embodiment, information relating to characteristics of the receive channels in use by a given remote site station 14a-14f is used to adjust a weighting vector of the TX beamformer 150a-150f associated with the given station 14a-14f.

The weighting vector of each TX beamformer 150a-150f is adjusted with sufficient regularity to ensure that the average signal power delivered to mobile units within the vicinity of each remote site station 14a-14f exceeds a predefined minimum value. It is observed that it will not typically be desirable to simply maximize the power received by each mobile unit by, for example, transmitting maximum power on

every frequency channel from each remote site station 14a-14f. If this approach is taken, there will likely be many instances in which the majority of the signal power received by a mobile unit on an assigned frequency channel is supplied by a given remote site station 14a-14f, but wherein the other remote site stations nonetheless also  
5 continue to transmit on the assigned channel. This leads to unnecessary interference power being transmitted to mobile units in other cells also operating upon the assigned frequency channel.

Accordingly, in the preferred embodiment the weighting vectors of the TX beamformers 150a-150f are adjusted such that only those remote site stations 14a-14f  
10 disposed to substantially improve the quality of the signal received by a given mobile unit on an assigned frequency channel are allowed to transmit on the assigned channel. It is expected that this will result in one, or perhaps two or three, remote site stations 14a-14f being allowed to transmit upon an assigned frequency channel at any given time. In the case of the forward control channel (FOCC), the weighting vectors of the  
15 TX beamformers 150a-150f will generally be set such that each remote site station 14a-14f broadcasts the FOCC with equal strength.

Each beamformer 158a-150f respectively produces N (where N is the number of modulators 110 which are actively producing outputs) parallel data streams consisting of 12 bit samples Each of the N data streams is a weighted baseband  
20 modulated channel signal. The parallel data streams destined for each of the remote site stations 14a-14f are multiplexed, along with control information from the controller 70 in one of the associated multiplexers 158a-158f. The multiplexers 158a-158f may be programmed to forego incorporating the data on channels which have been weighted by "0" in the TX beamformers 150a-150f. The resultant serial bit  
25 streams are then respectively transmitted by the forward channel communication link transmitters 58a-58f to the remote site stations 14a-14f.

Figure 6 is a block diagram of a distributed communication system in which modulation/demodulation functions, in addition to a channelizing function, are performed at the remote site station. In Figures 4-6, like reference numerals are used  
30 to identify those processing elements performing substantially similar functions. Within the remote site station 14a, signals received by the RX antennas 34 applied to frequency downconverter (DNX) 36 and translated to a lower frequency range. The



downconverted reverse channel spectrum is sampled by the ADC 40, and the resultant sampled spectrum provided to the remote site channelizers 120.

The 12-bit data samples corresponding to the channels extracted by the channelizer 120 are each provided to a remote site demodulator 180. In the exemplary  
5 AMPS embodiment, the demodulated digital waveform produced by each demodulator 180 is comprised of an approximately 8 kHz stream of 8-bit samples. The 8-bit samples primarily comprise digitized voice information, but also represent digital control messages intermittently transmitted by mobile unit for brief periods over reverse link voice channels. Each demodulator 180 is capable of distinguishing  
10 between voice and signaling information, and operates to "tag" the signaling information in order that it may be demultiplexed from the voice information within the central base station 18.

The demodulated data streams produced by the demodulator 180 are multiplexed into a composite data stream within a remote site time division multiplexer  
15 (TDM) 190. In addition, the remote site TDM 190 also multiplexes signal quality information from a signal quality receiver 194 into the composite data stream.

The signal quality receiver 194 functions to monitor the signal quality (e.g., average received power, or signal-to-noise ratio, or fading depth or duration) of each demodulated data stream produced by the channelizer 120. Signal quality information  
20 for each channel currently assigned to, or being monitored by, the remote site station 14a is provided by the receiver 194a in the form of a serial data stream of predetermined format.

In the exemplary AMPS embodiment, the signal quality receiver 194 also monitors the reverse control channel (RECC). An indication of RECC signal quality is  
25 provided to the TDM 190 following each access of the RECC by a mobile unit. In order to facilitate call set-up with each mobile unit, the receiver 194 appends header information to each RECC signal quality measurement. The header information specifies the mobile unit responsible for transmitting the RECC over the time period during which the RECC signal quality measurement was performed. Within the central  
30 base station 18, the controller 70 uses these RECC signal quality measurements as a basis for assigning remote site(s) 14a-14f in response to call set-up requests from mobile units.

The remote site controller 202 is primarily operative to implement instructions issued by the base station controller 70 relating to calls being handled by the remote site station 14a. Included among these instructions are, for example, the RF channel assigned to each call, and the time slot of the reverse link line 48a within which is inserted the demodulated data comprising each call. The remote site controller 202 effects the first of these instructions by commanding the channelizer 120 to extract the RF channels assigned to the remote site station 14a-14f from the digitized reverse channel spectrum. In like manner the TDM 190 is informed of the time slot of the reverse link line 48a allocated to each call being processed by the remote site station 14a.

Referring now to the implementation of the central base station 18 depicted in Figure 6, each time-division multiplexer (TDM) unit 208a-208f receives the voice data stream corresponding to a particular call from the demultiplexer 104. The demultiplexer 104 operates to distribute the time division multiplexed voice data received from the MTSO among the TDM units 208a-208f in response to control information received from the controller 70. Each TDM unit 208a-208f also receives a stream of forward control channel (FOCC) information, as well as control messages 28 generated by the base station controller 70. As is indicated by Figure 6, the three streams of information provided to each TDM unit 208a-208f are multiplexed into a single forward channel data stream and provided to the corresponding forward channel communication link transmitter 58a-58f.

Referring again to the implementation of the remote site station 14a of Figure 6, the forward channel communication link receiver 54 receives the forward channel data stream from the forward channel communication link transmitter 58a and forwards it to a remote site station TDM demultiplexer 218. The TDM demultiplexer 218 extracts the voice/data information corresponding to each call from the appropriate time slot of the received forward channel data stream. The extracted information is then distributed among a bank of digital modulators 222, which function substantially identically to the modulators 110 (Figure 4). The modulated data from the bank of digital modulators 222 is then processed by the digital transmitters 114, as well as by the remaining elements within transmit section of the remote site station 14a, in the manner described previously with reference to Figure 4.

Figure 7 is a block diagram of a distributed communication system in which modulation/demodulation, channelizing, and beamformer function are performed at the remote site station. Again, like reference numerals are used to identify those processing elements within Figure 7 performing functions substantially identical to those previously described. Within the remote site station 14a, signals received by the RX antennas 34 and 34a are respectively applied to frequency downconverters (DNX) 36 and 36a and translated to a lower frequency range. The downconverted reverse channel spectra are respectively sampled by the ADCs 40 and 40a, and the resultant sampled spectra provided to the remote site channelizers 120 and 120a.

Each channelizer 120 and 120a produces a data stream corresponding to each received frequency channel, and the pair of data streams for each channel are provided by the channelizers 120 and 120a to an associated one of the remote site beamformers 252. In the exemplary embodiment of Figure 7, each beamformer 252 functions to provide either selection diversity or adaptive beamforming. In the former case the beamformer 252 simply weights the highest quality data stream provided thereto by a factor of "1", and weights any other data streams upon the same frequency channel with a factor of "0". When adaptive beamforming is employed, each data stream is weighted in accordance with signal quality and the weighted streams subsequently combined. Similarly, TX beamforming (e.g. adaptive or selection) may be implemented for forward link transmissions. While two antennas are depicted in Figure 7 for reception and transmission respectively, antenna arrays of more than two elements may be used. Also, those skilled in the art will recognize that a single antenna array may be shared for reception and transmission through the use of diplexers.

Figure 8 is a flowchart representative of an exemplary manner in which calls are processed in accordance with the invention. As is indicated by Figure 8, the RECC is monitored for the presence of page responses or access attempts received from mobile units by one or more remote sites (step 402). Upon detection of a page response or access attempt (step 404), the controller 70 informs the MTSO and is assigned an RF channel thereby (step 406). It is then determined if the remote site station best able to establish communication with the mobile unit has been allocated the RF channel assigned by the MTSO (step 408). If so, the above-described call processing hardware (e.g., channelizers, beamformers, digital transmitters) within the

central and remote site stations are configured for operation on the assigned RF channel (step 410). If not, the controller 70 assigns a different RF channel to the mobile unit (step 412) and informs the MTSO of the change in channel frequency (step 414).

5           Once a suitable RF channel has been assigned and the central and remote site stations have been appropriately configured, call set-up instructions are sent to the mobile unit over the FOCC (step 416). In embodiments in which transmit (TX) beamforming capability is provided, the TX beamformers are adjusted so as to maximize the transmit power to the mobile unit (step 418). Call processing then  
10 proceeds in accordance with standard protocols (step 420), during which time the quality of the communication link to the mobile unit is monitored (step 422). This link quality monitoring may be performed within the mobile unit in some cellular standards, in which case signal quality information would be provided by the mobile unit to the remote site station(s) in communication therewith. Alternately, the remote  
15 site station(s) are configured with a signal quality receiver 194 (Figures 6 and 7) designed to monitor a given quality metric (e.g., signal to noise ratio). If TX and/or RX beamforming techniques prove incapable of maintaining the requisite signal quality, a hand-off request is issued to the MTSO (step 424) and control of the call is subsequently released in the usual way (step 426).

20           While the present invention has been described with reference to a few specific embodiments, the description is illustrative of the invention and is not to be construed as limiting the invention. Various modifications may occur to those skilled in the art while remaining within the spirit and scope of the invention as defined by the appended claims.

WHAT IS CLAIMED IS:

1. In a cellular system including a plurality of contiguous cells, a distributed microcellular communications systems disposed within one of said cells, said  
5 distributed microcellular communications system comprising:
  - a remote site station having a remote radio transceiver for transmitting and receiving information signals over an assigned set of communications channels within a first subcell within said one of said cells, said remote site station further including:
    - means for converting information signals received by said transceiver  
10 to reverse link digital information signals, and
    - a remote communications link transceiver for transmitting said reverse link digital information signals and for receiving forward link digital information signals; and
    - a central base station having a central communications link transceiver for  
15 receiving said reverse link digital information signals and for transmitting said forward link digital information signals.
2. The distributed microcellular communications system of claim 1 further including control means for allocating selected ones of a set of communications  
20 channels available to said one cell to said assigned set of communications channels.
3. The distributed microcellular communications system of claim 1 wherein said central base station further includes a central radio transceiver for transmitting and receiving information signals within a second subcell of said one cell, said  
25 communications system further including control means allocating selected ones of a set of communications channels available to said one cell to said assigned set of communications channels and for allocating remaining ones of said communications channels available to said one cell for use by said central radio transceiver.
- 30 4. The distributed microcellular communications system of claim 1 wherein said remote site station further includes channelizer means for selecting ones of said reverse link digital information signals corresponding to said assigned set of communications channels, said remote communications link transceiver transmitting

only said ones of said reverse link digital information signals corresponding to said assigned set of communications channels.

5. The distributed microcellular communications system of claim 4 wherein said  
5 remote site station further includes a multiplexer, interposed between said channelizer means and said remote communications link transceiver, for multiplexing said ones of said reverse link digital information signals corresponding to said assigned set of communications channels into a reverse link serial data stream.

10 6. The distributed microcellular communications system of claim 4 wherein said channelizer means further includes means for selecting other ones of said reverse link digital information signals, said remote site station further including a signal quality monitoring module for monitoring signal quality of said communications channels corresponding to said other ones of said reverse link digital information signals.

15

7. The distributed microcellular communications system of claim 1 wherein said remote site station further includes:

channelizer means for selecting a set of said reverse link digital information signals corresponding to said assigned set of communications channels, and

20

demodulator means for demodulating said set of said reverse link digital information signals to produce a set of demodulated reverse link digital information signals, said remote communications link transceiver including means for transmitting said demodulated reverse link digital information signals.

25 8. The distributed microcellular communications system of claim 1 wherein said remote site station further includes:

digital modulator means for modulating a carrier signal with said forward link digital information signals, thereby producing a plurality of modulated carrier signals, and

30

digital transmitter means for translating frequency of said plurality of modulated carrier signals in order that each of said signals occupy an assigned frequency channel within a digitized forward link transmission spectrum.

9. The distributed microcellular communications system of claim 8 wherein digital transmitter means includes:
- a plurality of digital transmitters, each of said digital transmitters being disposed to modulate one of said carrier signals with one of said forward link digital information signals,
  - a digital to analog converter, and
  - a digital summer interposed between said digital to analog converter and said plurality of digital transmitters.
10. The distributed microcellular communications system of claim 8 wherein said remote site station further includes wideband transmitter means for translating frequency of said modulated carrier signals into a frequency-shifted forward link transmission spectrum.
11. In a cellular system including at least a first cell having a cell-site, a distributed microcellular communications system comprising:
- a central base station, located at said cell-site, having a central communications link transmitter for transmitting forward link digital information signals, each of said forward link digital information signals being produced by modulating a digitized carrier signal; and
  - a remote site station, said remote site station having at least:
    - a remote communications link receiver for receiving said forward link digital information signals,
    - means for converting said forward link digital information signals into frequency-shifted forward link analog information signals, and
    - a remote radio transmitter for transmitting said frequency-shifted forward link analog information signals within a first subcell of said first cell.
12. The distributed microcellular communications system of claim 11 wherein said remote site station further includes:

- a wideband receiver for receiving reverse link information signals and for converting frequency of said reverse link information signals into a frequency-shifted reverse link spectrum so as to produce frequency-shifted reverse link information signals,
- 5 an analog to digital converter for converting said frequency-shifted reverse link information signals into reverse link digital information signals, and
- a remote communications link transmitter for transmitting said reverse link digital information signals.
- 10 13. In a cellular system including at least a first cell having a cell-site, a distributed microcellular communications system comprising:
- a remote site station including:
- a wideband receiver for receiving reverse link information signals from users within a first subcell of said first cell, and for converting frequency of
- 15 said reverse link information signals into a frequency-shifted reverse link spectrum so as to produce frequency-shifted reverse link information signals,
- an analog to digital converter for converting said frequency-shifted reverse link information signals into reverse link digital information signals,
- a channelizer for selecting ones of said reverse link digital information
- 20 signals corresponding to channel frequencies assigned to said remote site station, and
- a remote communications link transmitter for transmitting said reverse link digital information signals; and
- a central base station, located at said cell-site, having a central communications
- 25 link receiver for receiving said reverse link digital information signals.
14. The distributed microcellular communications system of claim 13 wherein said central base station further includes a central radio transceiver for transmitting and receiving information signals within a second subcell of said first cell, said
- 30 communications system further including control means allocating selected ones of an available set of communications channels to said channel frequencies assigned to said remote site station and for allocating remaining ones of said available set of communications channels for use by said central radio transceiver.



15. The distributed microcellular communications system of claim 1 wherein said means for converting information signals received by said transceiver to reverse link digital information signals includes:
- a wideband receiver for translating frequency of said information signals received by said transceiver to a frequency-shifted reverse channel spectrum, and an analog to digital converter coupled to said wideband receiver.
16. In a cellular system including a plurality of contiguous cells, a method for providing distributed microcellular communication within one cell of said cells, said method comprising the steps of:
- at a remote site station located within said one cell:
    - transmitting and receiving information signals over an assigned set of communications channels within a first subcell of said one cell,
    - converting information signals received by said remote site station from users within said first subcell into reverse link digital information signals, transmitting said reverse link digital information signals; and
  - at a central base station located at a cell-site of said first cell:
    - receiving said reverse link digital information signals.
17. The method of claim 16 wherein said step of converting includes the steps of:
- translating frequency of said information signals received by said remote site station into a frequency-shifted reverse link spectrum so as to provide frequency-shifted reverse link information signals, and
  - converting said frequency-shifted reverse link information signals into said reverse link digital information signals.
18. The method of claim 17 further including the steps of:
- at said central base station, transmitting forward link digital information signals; and
  - at said remote site station:
    - receiving said forward link digital information signals,
    - converting said forward link digital information signals into frequency-shifted forward link digital information signals, and

converting said frequency-shifted forward link digital information signals into analog forward link information signals within a forward link transmission spectrum.

5 19. In a cellular system including a plurality of contiguous cells, a distributed microcellular communications systems disposed within one of said cells, said distributed microcellular communications system comprising:

a plurality of remote site stations respectively disposed within a plurality of subcells of said one cell, each of said plurality of remote site stations having a remote  
10 radio transceiver for transmitting and receiving information signals over an assigned set of communications channels, each of said remote site stations further including means for converting information signals received by said remote radio transceiver included therein to reverse link digital information signals for transmission by a remote station communications link transmitter; and

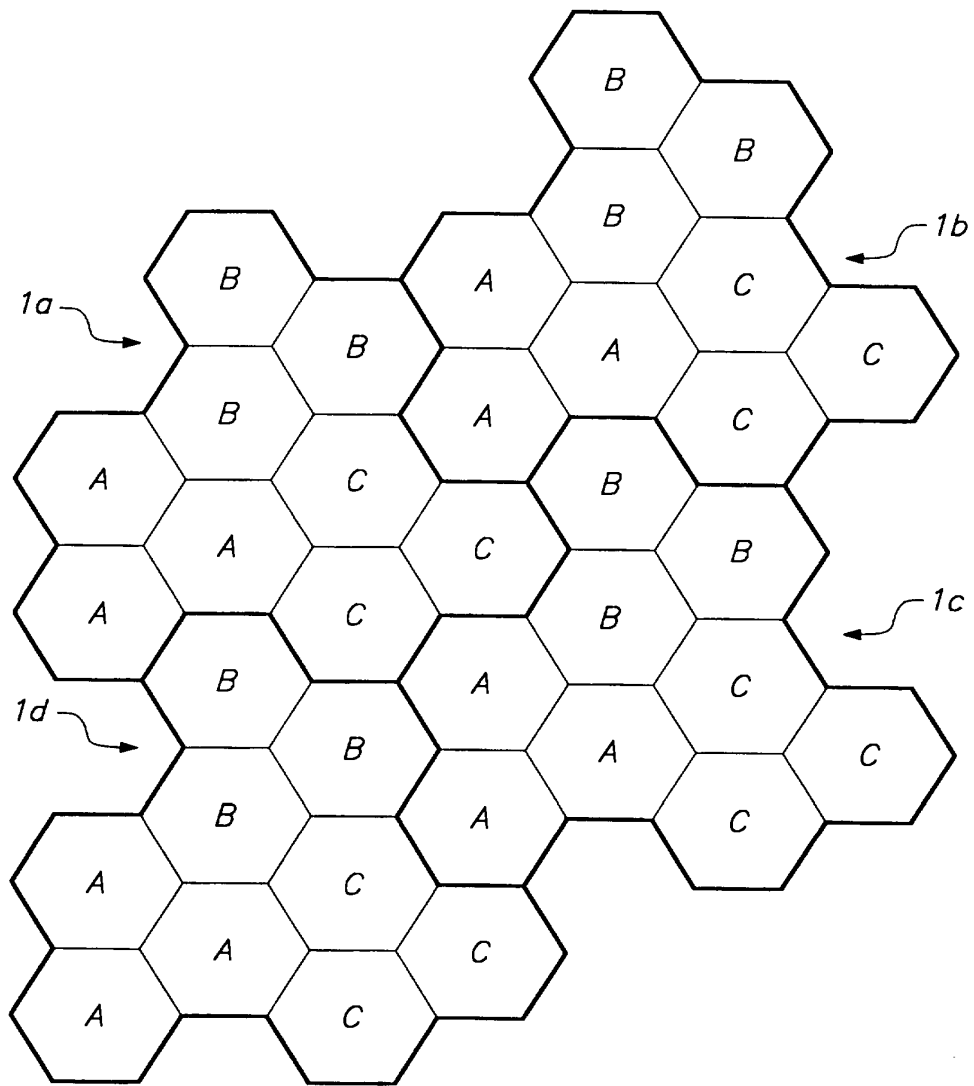
15 a central base station having a central communications link receiver for receiving said reverse link digital information signals from said plurality of remote site stations.

20. The distributed microcellular communications system of claim 19 further  
20 including means for allocating communication channels from an available set of communication channels to each said assigned set of communication channels, thereby permitting establishment of a desired channel capacity within each of said subcells.

21. The distributed microcellular communications system of claim 19 wherein said  
25 central base station further includes central communications link transmitter means for transmitting a plurality of forward link digital information signals to said plurality of remote site stations.

22. The distributed microcellular communications system of claim 7 wherein said  
30 remote site station further includes a plurality of beamformers disposed to receive said set of reverse link digital information signals, said demodulator means including a corresponding plurality of digital demodulator coupled to said plurality of beamformers.

23. The distributed microcellular communications system of claim 11 wherein said cell-site station further includes beamforming means for providing said forward link digital information signals to said communications link transmitter.
- 5 24. In a cellular system including a plurality of contiguous cells, a distributed microcellular communications system disposed within one of said cells, said distributed microcellular communications system comprising:
- a plurality of remote site stations respectively situated in a like plurality of subcells within said one of said cells, each of said plurality of remote site stations
- 10 having a remote radio transceiver for transmitting and receiving information signals over an assigned set of communications channels, each of said remote site stations further including:
- means for converting information signals received by said transceiver to reverse link digital information signals, and
- 15 a remote communications link transceiver for transmitting said reverse link digital information signals and for receiving forward link digital information signals; and
- a central base station having a central communications link transceiver for receiving said reverse link digital information signals from each of said plurality of
- 20 remote site stations, and for selectively transmitting said forward link digital information signals to each of said plurality of remote site stations.
25. The distributed microcellular communications system of claim 1 wherein said remote site station further includes a diversity remote radio receiver for receiving
- 25 information signals over said assigned set of communications channels within said first subcell, said remote site station further including a diversity combiner for combining said information signals received by said diversity remote radio receiver with said information signals received by said remote radio transceiver.



**FIG. 1A**

SUBSTITUTE SHEET (RULE 26)

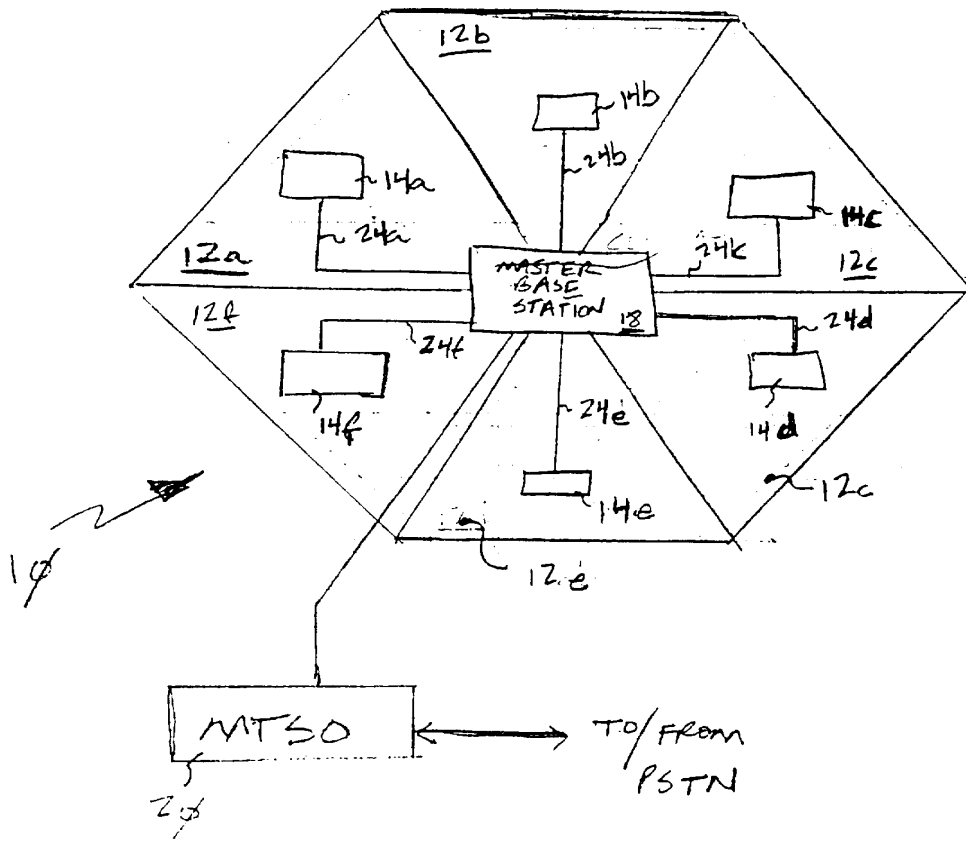


FIG. 1B

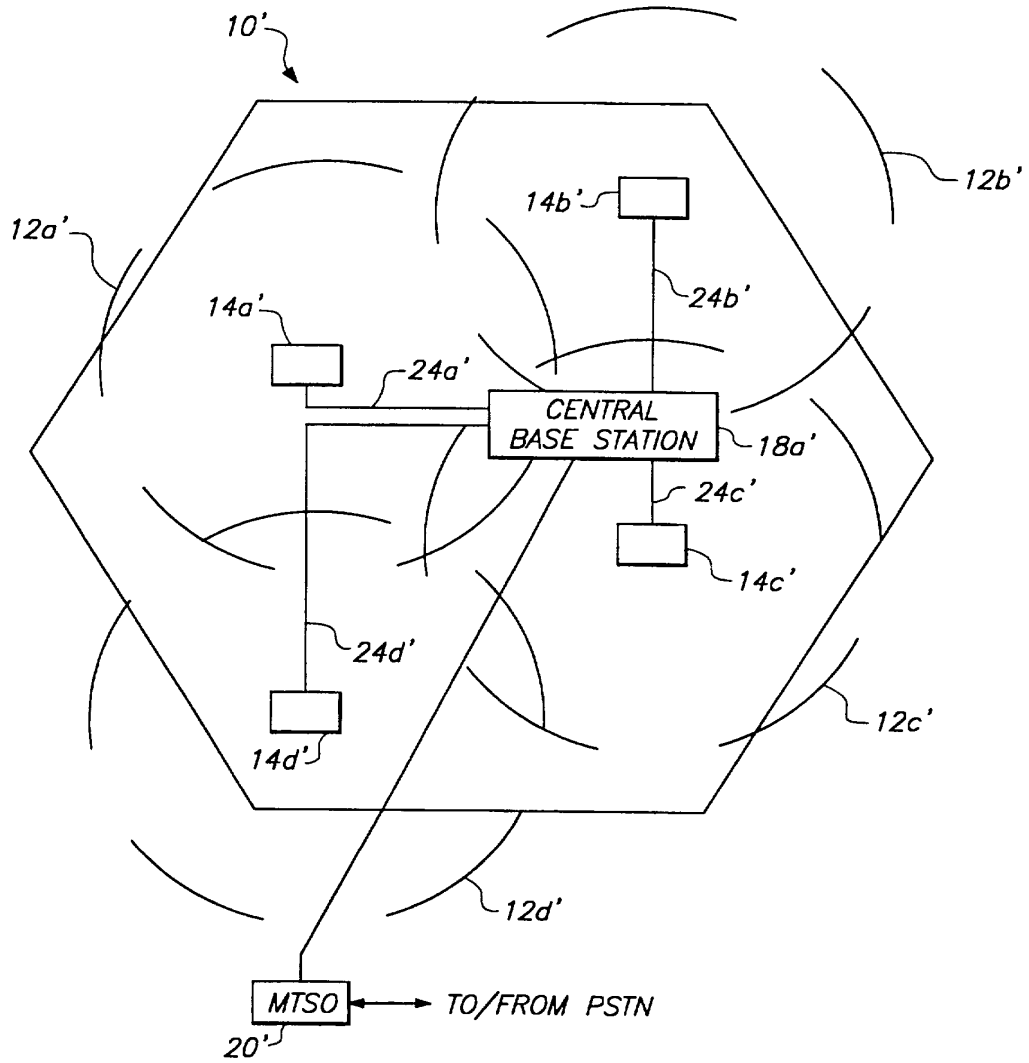


FIG. 1C

SUBSTITUTE SHEET (RULE 26)

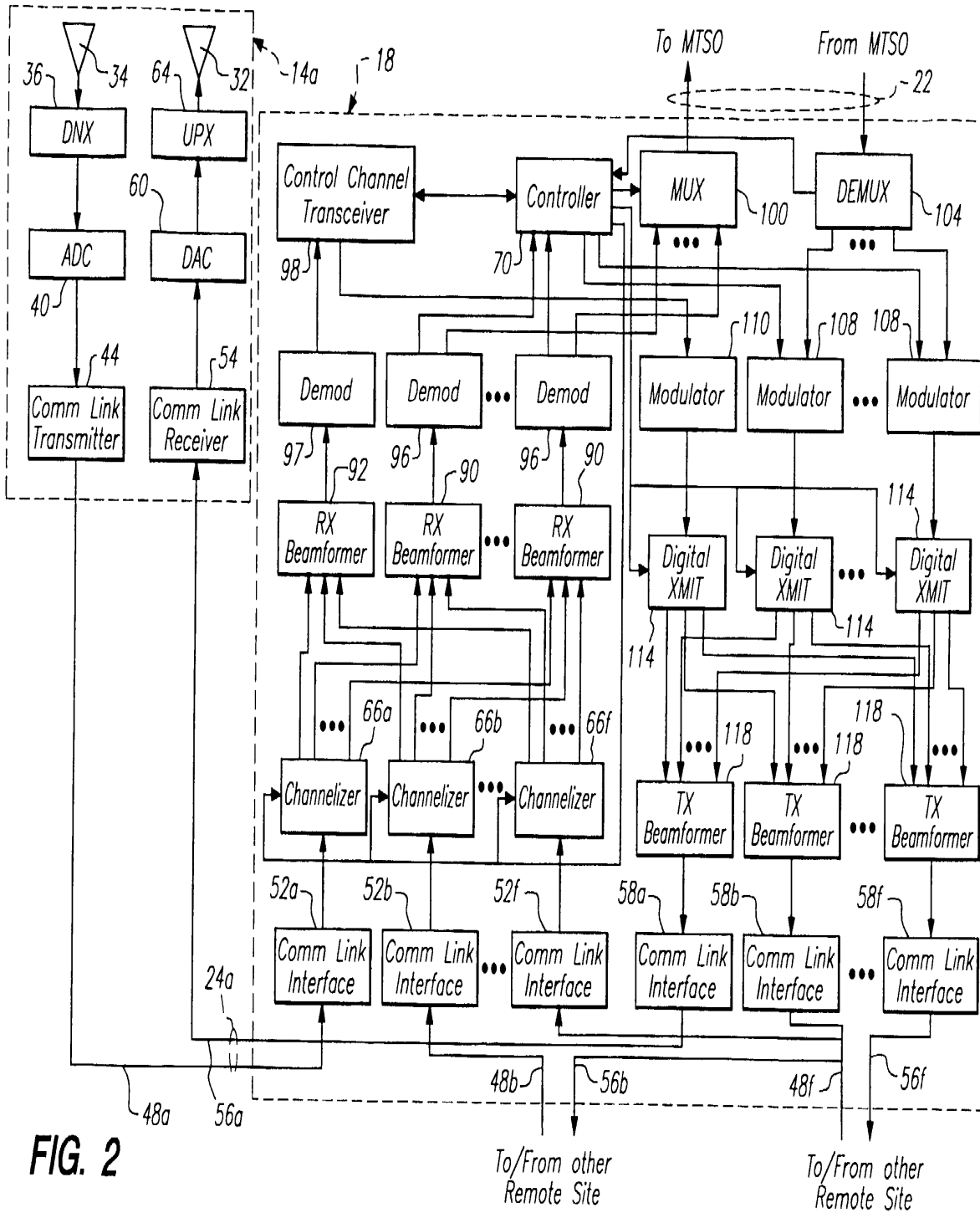
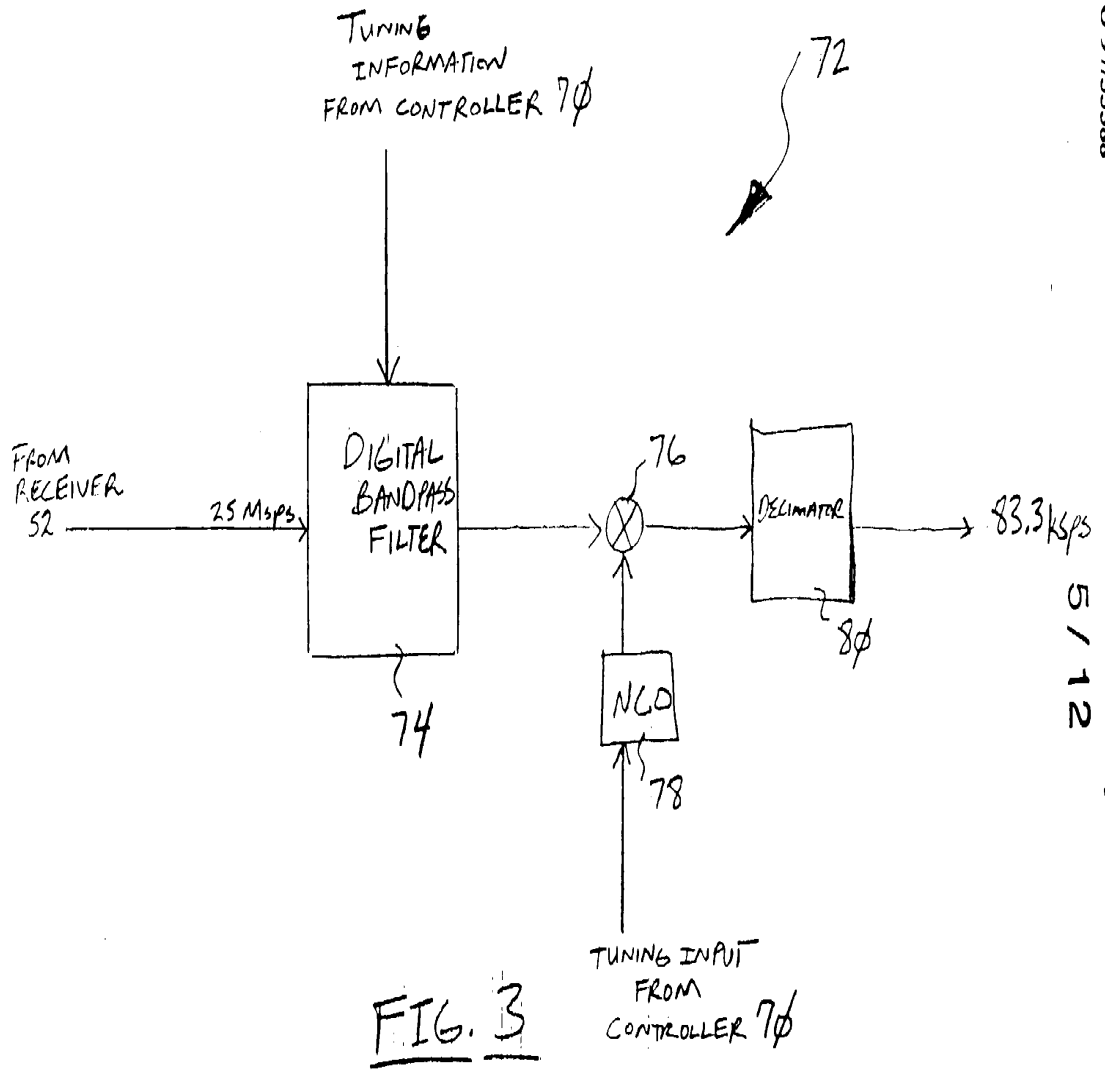


FIG. 2





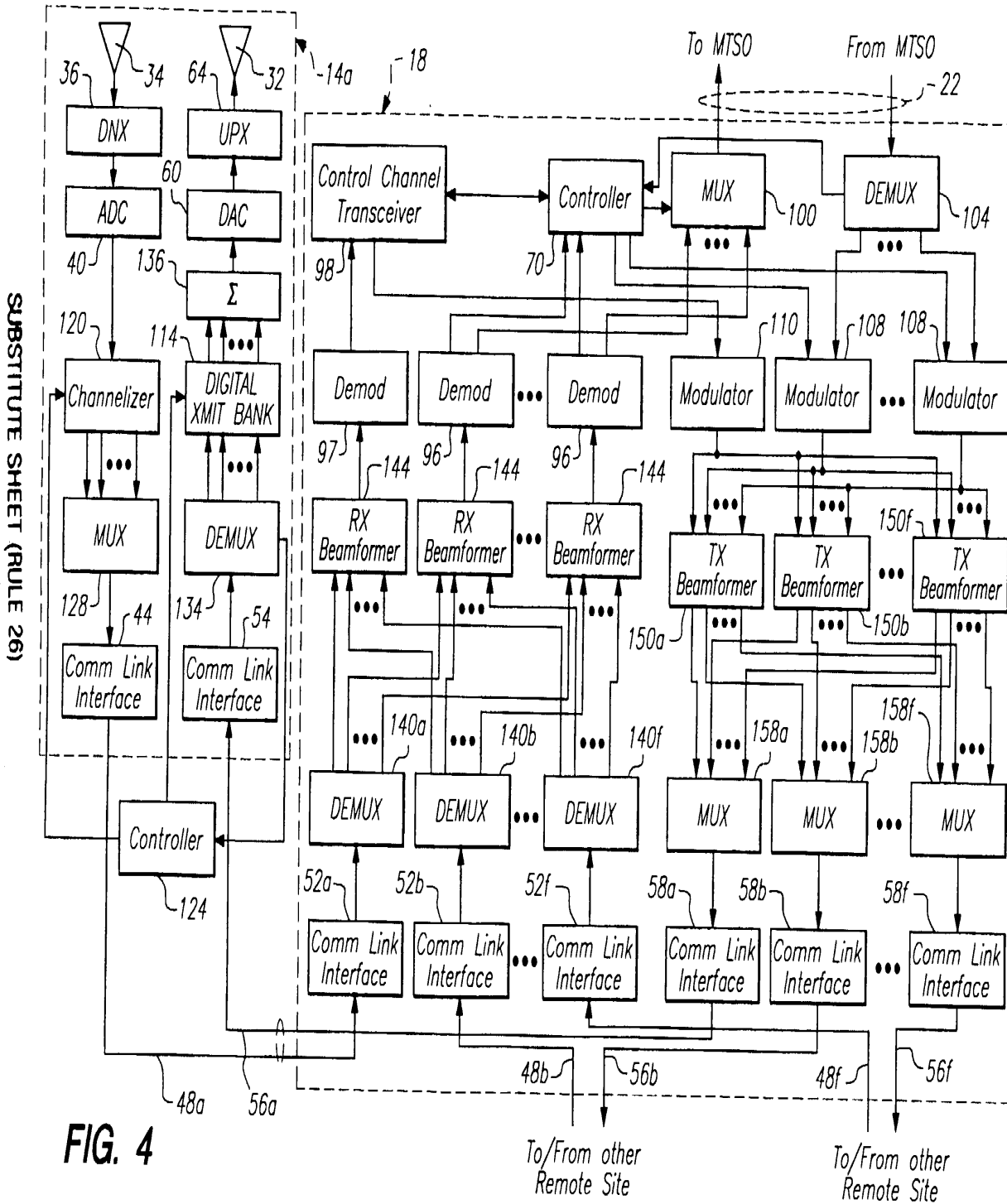


FIG. 4

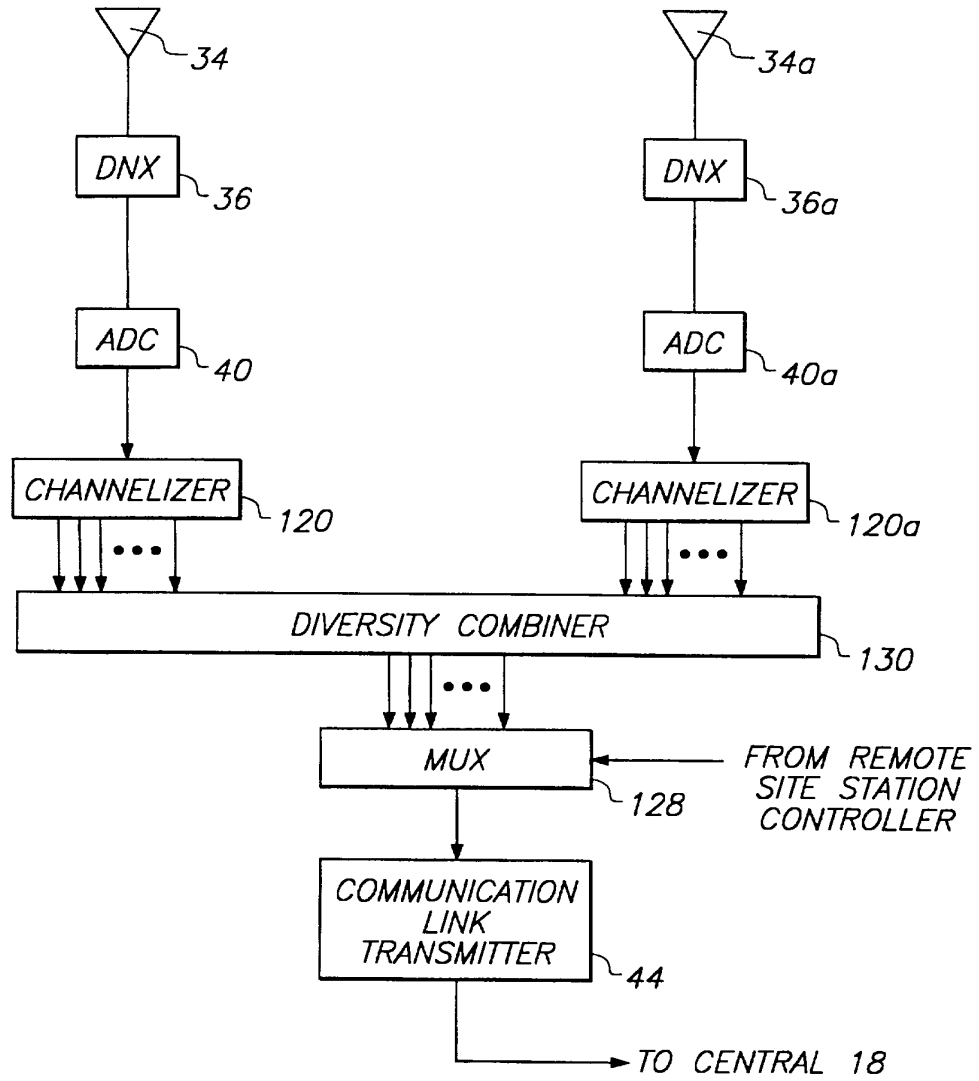


FIG. 5

SUBSTITUTE SHEET (RULE 26)

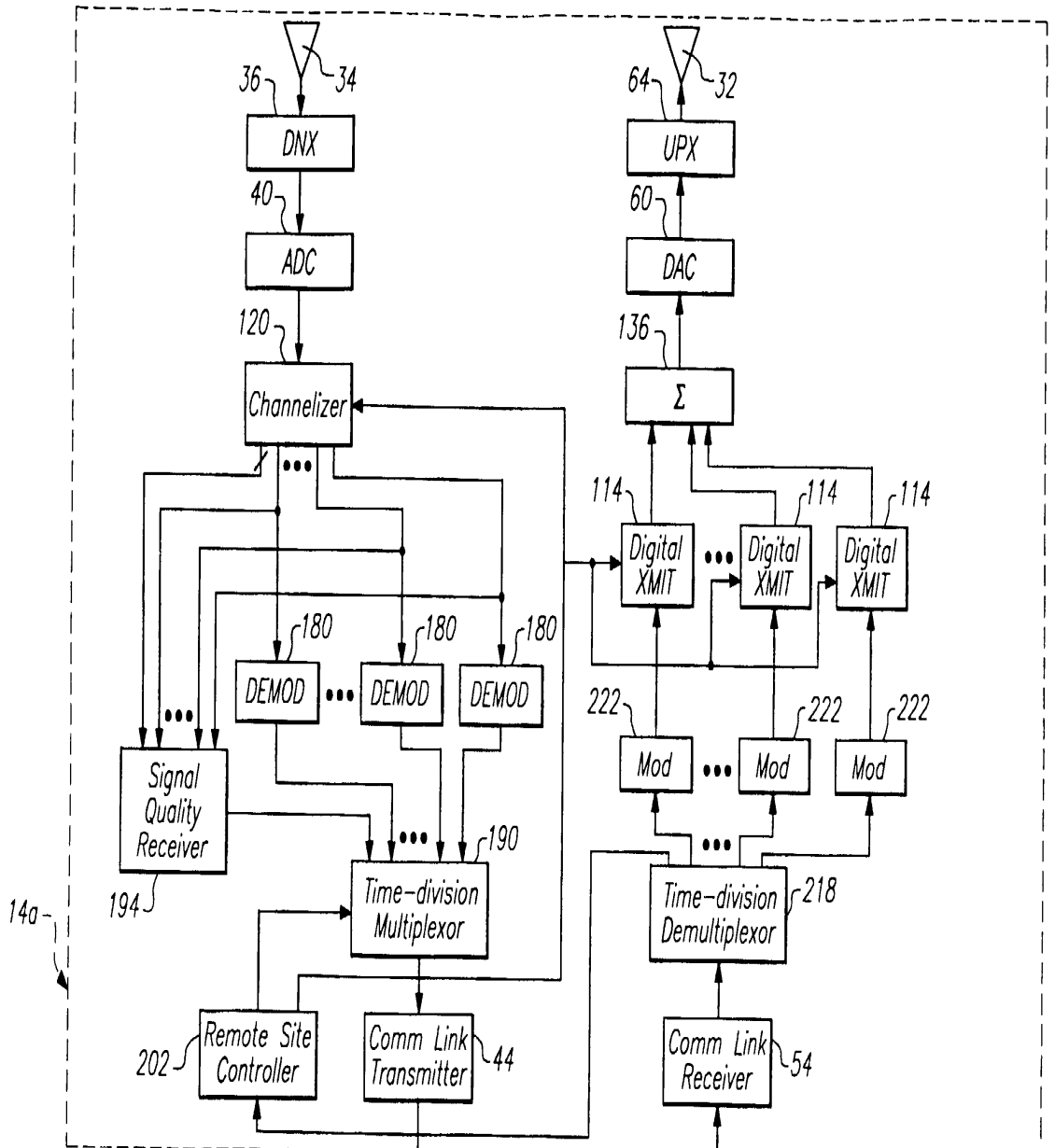


FIG. 6

FIG. 6A

FIG. 6A	FIG. 6B
------------	------------

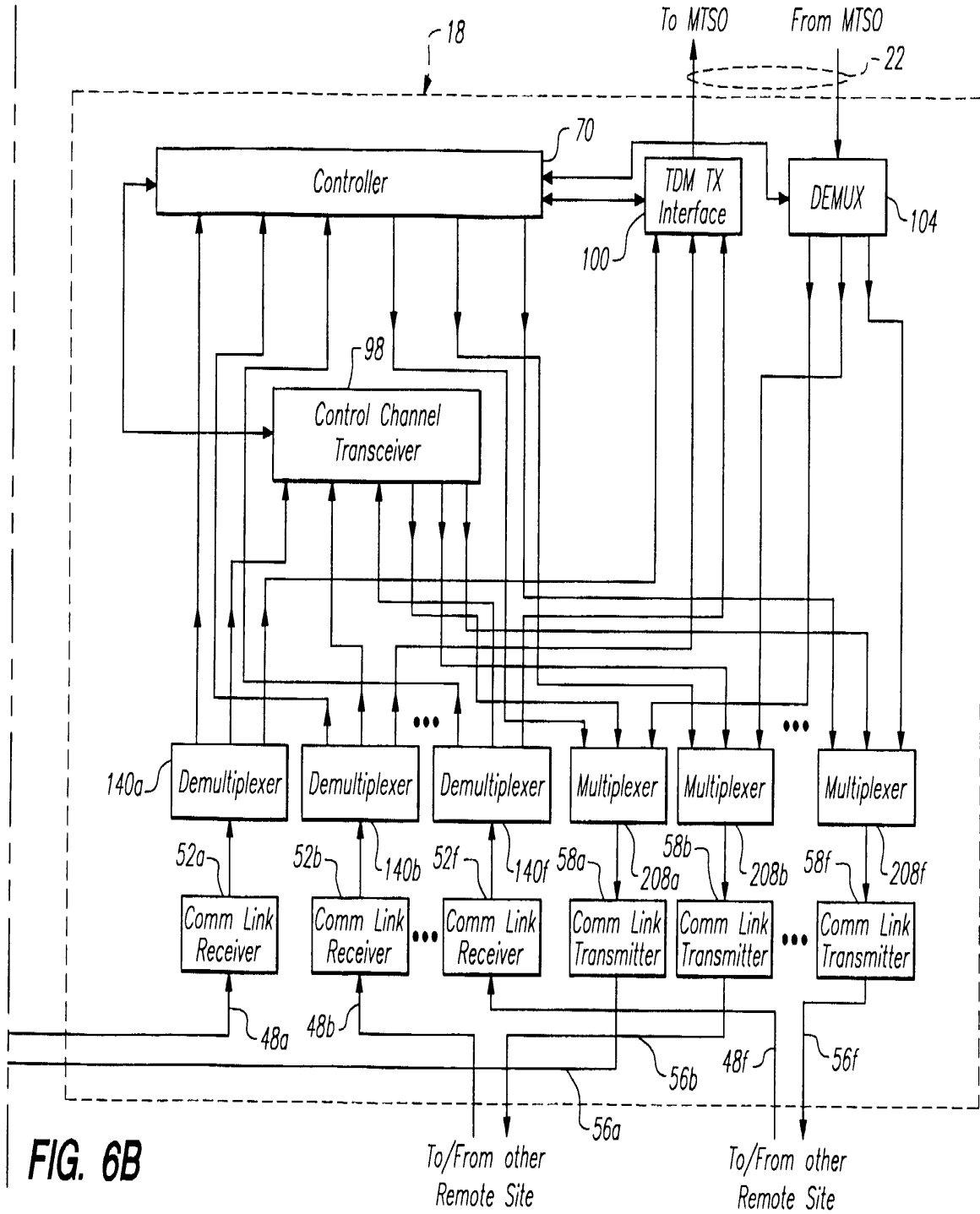


FIG. 6B

SUBSTITUTE SHEET (RULE 26)

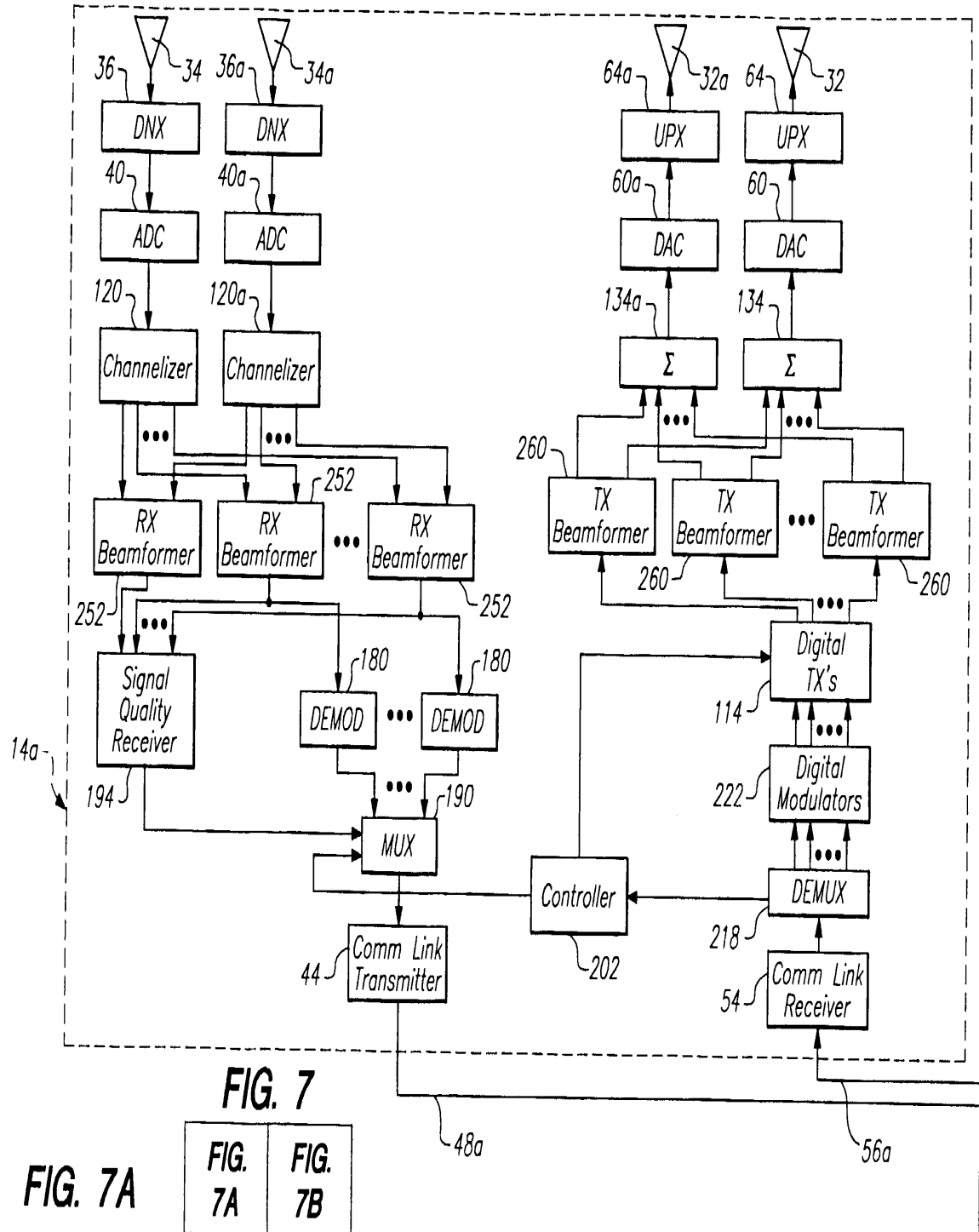


FIG. 7

FIG. 7A

FIG. 7A	FIG. 7B
---------	---------

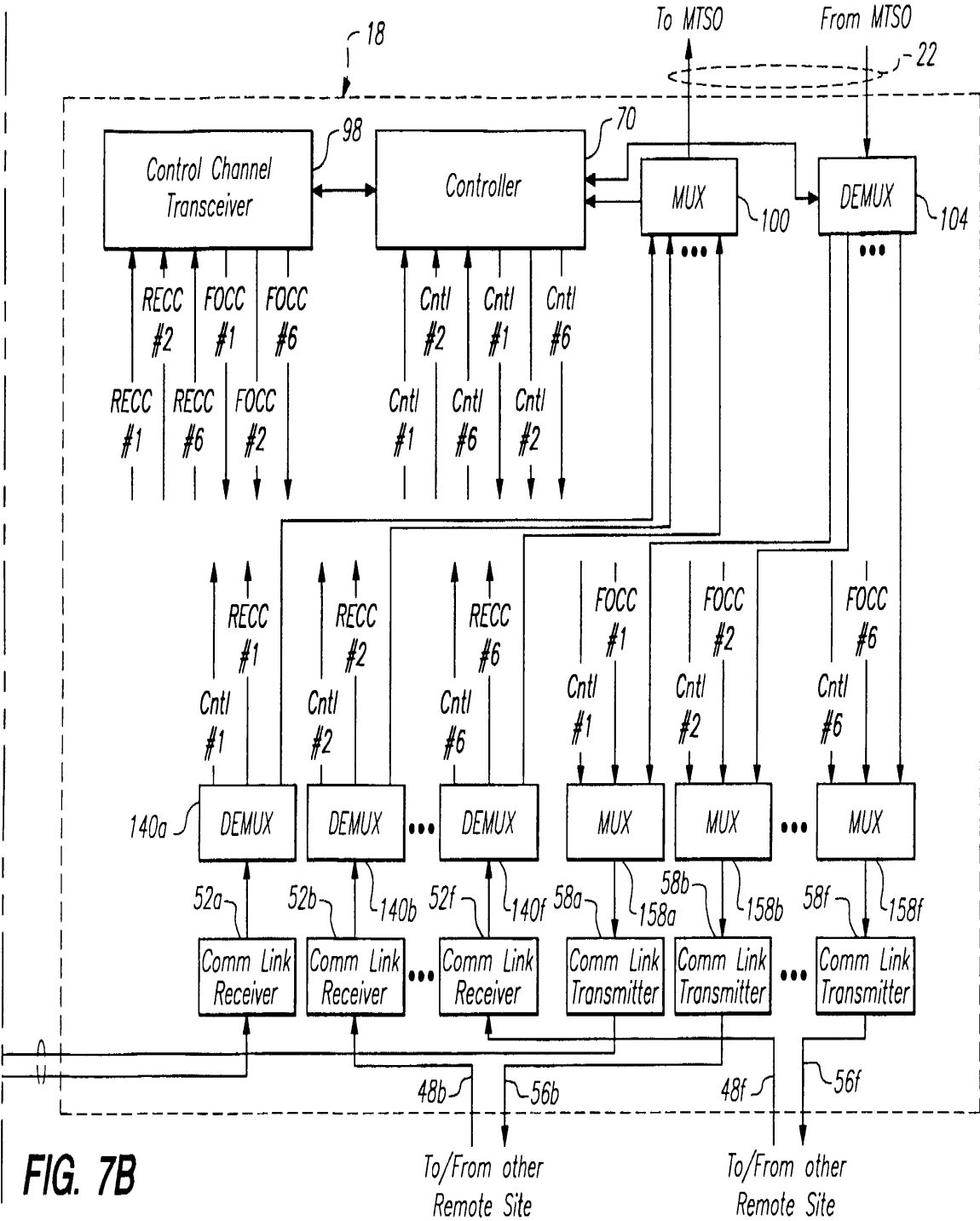


FIG. 7B

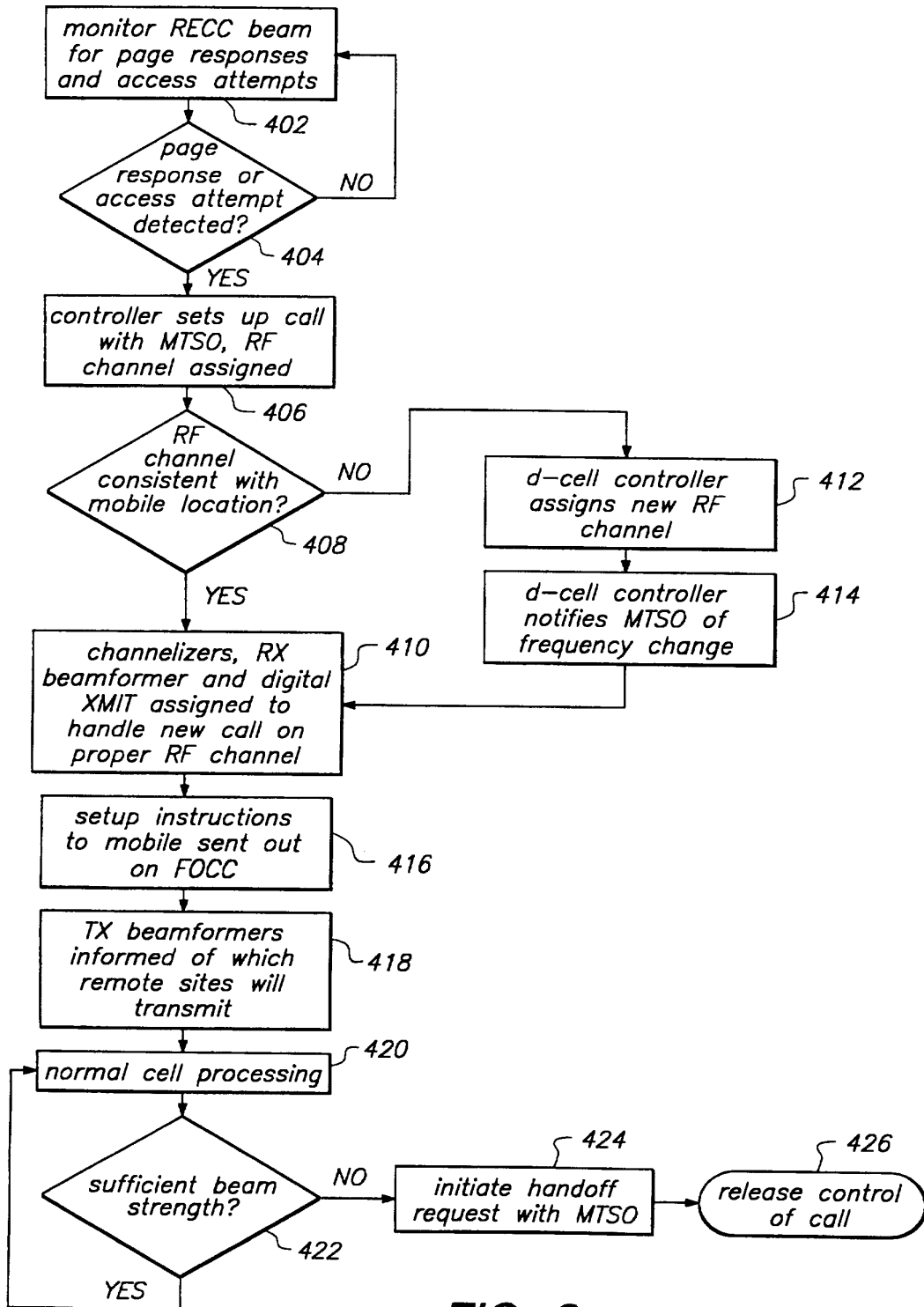


FIG. 8

SUBSTITUTE SHEET (RULE 26)

INTERNATIONAL SEARCH REPORT

International application No.  
PCT/US97/03629

<b>A. CLASSIFICATION OF SUBJECT MATTER</b>																										
IPC(6) :H04B 7/26 US CL :455/33.1																										
According to International Patent Classification (IPC) or to both national classification and IPC																										
<b>B. FIELDS SEARCHED</b>																										
Minimum documentation searched (classification system followed by classification symbols)																										
U.S. : 455/33.1, 33.2, 33.3, 33.4, 39, 49.1, 53.1, 54.1, 57.1, 73, 80																										
Documentation searched other than minimum documentation to the extent that such documents are included in the fields searched																										
Electronic data base consulted during the international search (name of data base and, where practicable, search terms used)																										
APS IMAGE																										
<b>C. DOCUMENTS CONSIDERED TO BE RELEVANT</b>																										
Category*	Citation of document, with indication, where appropriate, of the relevant passages	Relevant to claim No.																								
A	US 5,448,753 A (AHL et al) 05 September 1995, fig. 21; col. 1, lines 21-25, 28-32; col. 3, lines 10-16, 25-32, 43-68; col. 4, lines 36-44.	1-25																								
A	US 5,463,671 A (MARSH et al) 31 October 1995, fig. 1; col. 1, lines 30-67 through col. 4, lines 1-7.	1-25																								
Y	US 5,481,546 A (DINKINS) 02 January 1996, figs. 2, 6A-6B; col. 1, lines 15-23; col. 2, lines 55-61; col. 3, lines 2-11, 56-67; col. 5, lines 43-60; col. 6, lines 17-40; col. 8, lines 38-61; col. 9, lines 5-15, 48-67.	1-25																								
<input checked="" type="checkbox"/> Further documents are listed in the continuation of Box C. <input type="checkbox"/> See patent family annex.																										
<table border="0"> <tr> <td>* Special categories of cited documents:</td> <td>*T</td> <td>later document published after the international filing date or priority date and not in conflict with the application but cited to understand the principle or theory underlying the invention</td> </tr> <tr> <td>*A</td> <td>document defining the general state of the art which is not considered to be part of particular relevance</td> <td></td> </tr> <tr> <td>*E</td> <td>earlier document published on or after the international filing date</td> <td>*X</td> </tr> <tr> <td>*L</td> <td>document which may throw doubts on priority claim(s) or which is cited to establish the publication date of another citation or other special reason (as specified)</td> <td>document of particular relevance; the claimed invention cannot be considered novel or cannot be considered to involve an inventive step when the document is taken alone</td> </tr> <tr> <td>*O</td> <td>document referring to an oral disclosure, use, exhibition or other means</td> <td>*Y</td> </tr> <tr> <td>*P</td> <td>document published prior to the international filing date but later than the priority date claimed</td> <td>document of particular relevance; the claimed invention cannot be considered to involve an inventive step when the document is combined with one or more other such documents, such combination being obvious to a person skilled in the art</td> </tr> <tr> <td></td> <td></td> <td>*&amp;</td> </tr> <tr> <td></td> <td></td> <td>document member of the same patent family</td> </tr> </table>			* Special categories of cited documents:	*T	later document published after the international filing date or priority date and not in conflict with the application but cited to understand the principle or theory underlying the invention	*A	document defining the general state of the art which is not considered to be part of particular relevance		*E	earlier document published on or after the international filing date	*X	*L	document which may throw doubts on priority claim(s) or which is cited to establish the publication date of another citation or other special reason (as specified)	document of particular relevance; the claimed invention cannot be considered novel or cannot be considered to involve an inventive step when the document is taken alone	*O	document referring to an oral disclosure, use, exhibition or other means	*Y	*P	document published prior to the international filing date but later than the priority date claimed	document of particular relevance; the claimed invention cannot be considered to involve an inventive step when the document is combined with one or more other such documents, such combination being obvious to a person skilled in the art			*&			document member of the same patent family
* Special categories of cited documents:	*T	later document published after the international filing date or priority date and not in conflict with the application but cited to understand the principle or theory underlying the invention																								
*A	document defining the general state of the art which is not considered to be part of particular relevance																									
*E	earlier document published on or after the international filing date	*X																								
*L	document which may throw doubts on priority claim(s) or which is cited to establish the publication date of another citation or other special reason (as specified)	document of particular relevance; the claimed invention cannot be considered novel or cannot be considered to involve an inventive step when the document is taken alone																								
*O	document referring to an oral disclosure, use, exhibition or other means	*Y																								
*P	document published prior to the international filing date but later than the priority date claimed	document of particular relevance; the claimed invention cannot be considered to involve an inventive step when the document is combined with one or more other such documents, such combination being obvious to a person skilled in the art																								
		*&																								
		document member of the same patent family																								
Date of the actual completion of the international search		Date of mailing of the international search report																								
17 JUNE 1997		29 JUL 1997																								
Name and mailing address of the ISA/US Commissioner of Patents and Trademarks Box PCT Washington, D.C. 20231		Authorized officer <i>Tommy Chin</i> TOMMY CHIN																								
Facsimile No. (703) 305-3230		Telephone No. (703) 305-4715																								

Form PCT/ISA/210 (second sheet)(July 1992)\*



## INTERNATIONAL SEARCH REPORT

International application No.  
PCT/US97/03629

C (Continuation). DOCUMENTS CONSIDERED TO BE RELEVANT		
Category*	Citation of document, with indication, where appropriate, of the relevant passages	Relevant to claim No.
Y, P	US 5,555,260 A (RINNBACK et al) 10 September 1996, col. 1, lines 20-50; col. 3, lines 23-40; col. 4, lines 28-45; col. 5, lines 26-46; col. 8, lines 55-65; col. 9, lines 57 through col. 10, lines 1-15.	1-25
A, P	US 5,542,107 A (KAY) 30 July 1996, col. 1, lines 14-23; col. 4, lines 39-58; col. 6, lines 10-16.	1-25
Y	US 5,333,178 A (NORELL) 26 July 1994, col. 1, lines 16-26, 36-37, 43-45; col. 2, lines 8-19, 44-63; col. 3, lines 16-28.	1-25

Form PCT/ISA/210 (continuation of second sheet)(July 1992)\*



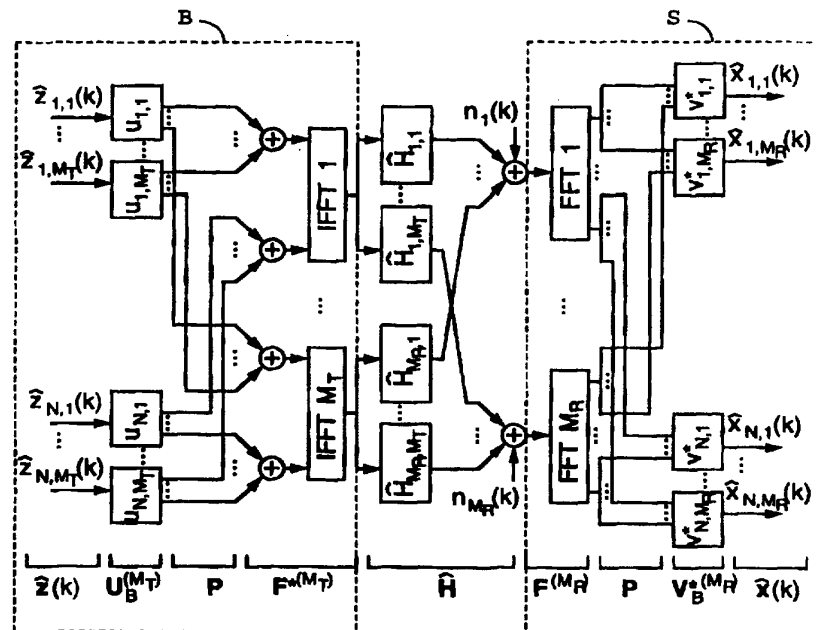
INTERNATIONAL APPLICATION PUBLISHED UNDER THE PATENT COOPERATION TREATY (PCT)

<p>(51) International Patent Classification <sup>6</sup> : <b>H04B 1/38, H04M 1/00</b></p>	<p>A1</p>	<p>(11) International Publication Number: <b>WO 98/09381</b> (43) International Publication Date: 5 March 1998 (05.03.98)</p>
<p>(21) International Application Number: PCT/US97/15363 (22) International Filing Date: 29 August 1997 (29.08.97) (30) Priority Data: 60/025,227 29 August 1996 (29.08.96) US 60/025,228 29 August 1996 (29.08.96) US (71) Applicant: THE BOARD OF TRUSTEES OF THE LELAND STANFORD JUNIOR UNIVERSITY [US/US]; Suite 350, 900 Welch Road, Palo Alto, CA 94304 (US). (72) Inventors: RALEIGH, Gregory, G.; 539 San Juan Avenue, El Granada, CA 94018 (US). CIOFFI, John, M.; 14298 Saddle Mountain Drive, Los Altos Hills, CA 94022 (US). (74) Agent: McFARLANE, Thomas, J.; 426 Lowell Avenue, Palo Alto, CA 94301 (US).</p>	<p>(81) Designated States: CA, JP, MX, European patent (AT, BE, CH, DE, DK, ES, FI, FR, GB, GR, IE, IT, LU, MC, NL, PT, SE).  Published <i>With international search report.</i></p>	

(54) Title: HIGH CAPACITY WIRELESS COMMUNICATION USING SPATIAL SUBCHANNELS

(57) Abstract

In a system and method of digital wireless communication between a base station (B) and a subscriber unit (S), a spatial channel characterized by a channel matrix H couples an adaptive array of Mt antenna elements (1-Mt) at the base station (B) with an adaptive array Mr antenna elements (1-Mr) at the subscriber unit (S). The method comprises the step of determining from the channel matrix H a number L of independent spatio-temporal subchannels, and encoding a plurality of information signals into a sequence of transmitted signal vectors. The transmitted signal vectors have Mt complex valued components and are selected to transmit distinct signal information in parallel over the independent subchannels, thereby providing increased communication capacity between the base and the subscriber. The sequence of transmitted signal vectors is transmitted from the base station array (1-Mt), and a sequence of received signal vectors is received at the subscriber array (1-Mr) and are decoded to yield the original information signals. Specific spatio-temporal coding techniques are described that increase system performance.



**FOR THE PURPOSES OF INFORMATION ONLY**

Codes used to identify States party to the PCT on the front pages of pamphlets publishing international applications under the PCT.

<b>AL</b>	Albania	<b>ES</b>	Spain	<b>LS</b>	Lesotho	<b>SI</b>	Slovenia
<b>AM</b>	Armenia	<b>FI</b>	Finland	<b>LT</b>	Lithuania	<b>SK</b>	Slovakia
<b>AT</b>	Austria	<b>FR</b>	France	<b>LU</b>	Luxembourg	<b>SN</b>	Senegal
<b>AU</b>	Australia	<b>GA</b>	Gabon	<b>LV</b>	Latvia	<b>SZ</b>	Swaziland
<b>AZ</b>	Azerbaijan	<b>GB</b>	United Kingdom	<b>MC</b>	Monaco	<b>TD</b>	Chad
<b>BA</b>	Bosnia and Herzegovina	<b>GE</b>	Georgia	<b>MD</b>	Republic of Moldova	<b>TG</b>	Togo
<b>BB</b>	Barbados	<b>GH</b>	Ghana	<b>MG</b>	Madagascar	<b>TJ</b>	Tajikistan
<b>BE</b>	Belgium	<b>GN</b>	Guinea	<b>MK</b>	The former Yugoslav Republic of Macedonia	<b>TM</b>	Turkmenistan
<b>BF</b>	Burkina Faso	<b>GR</b>	Greece	<b>ML</b>	Mali	<b>TR</b>	Turkey
<b>BG</b>	Bulgaria	<b>HU</b>	Hungary	<b>MN</b>	Mongolia	<b>TT</b>	Trinidad and Tobago
<b>BJ</b>	Benin	<b>IE</b>	Ireland	<b>MR</b>	Mauritania	<b>UA</b>	Ukraine
<b>BR</b>	Brazil	<b>IL</b>	Israel	<b>MW</b>	Malawi	<b>UG</b>	Uganda
<b>BY</b>	Belarus	<b>IS</b>	Iceland	<b>MX</b>	Mexico	<b>US</b>	United States of America
<b>CA</b>	Canada	<b>IT</b>	Italy	<b>NE</b>	Niger	<b>UZ</b>	Uzbekistan
<b>CF</b>	Central African Republic	<b>JP</b>	Japan	<b>NL</b>	Netherlands	<b>VN</b>	Viet Nam
<b>CG</b>	Congo	<b>KE</b>	Kenya	<b>NO</b>	Norway	<b>YU</b>	Yugoslavia
<b>CH</b>	Switzerland	<b>KG</b>	Kyrgyzstan	<b>NZ</b>	New Zealand	<b>ZW</b>	Zimbabwe
<b>CI</b>	Côte d'Ivoire	<b>KP</b>	Democratic People's Republic of Korea	<b>PL</b>	Poland		
<b>CM</b>	Cameroon	<b>KR</b>	Republic of Korea	<b>PT</b>	Portugal		
<b>CN</b>	China	<b>KZ</b>	Kazakistan	<b>RO</b>	Romania		
<b>CU</b>	Cuba	<b>LC</b>	Saint Lucia	<b>RU</b>	Russian Federation		
<b>CZ</b>	Czech Republic	<b>LI</b>	Liechtenstein	<b>SD</b>	Sudan		
<b>DE</b>	Germany	<b>LK</b>	Sri Lanka	<b>SE</b>	Sweden		
<b>DK</b>	Denmark	<b>LR</b>	Liberia	<b>SG</b>	Singapore		
<b>EE</b>	Estonia						

High Capacity Wireless Communication  
Using Spatial Subchannels

5

**RELATED APPLICATIONS**

This application claims priority from U.S. provisional  
10 applications 60/025,227 and 60/025,228, both filed 08/29/96.  
Both applications are hereby incorporated by reference.

**FIELD OF THE INVENTION**

This invention relates generally to digital wireless  
15 communication systems. More particularly, it relates to using  
antenna arrays by both a base station and a subscriber to  
significantly increase the capacity of wireless communication  
systems.

20

**BACKGROUND OF THE INVENTION**

Due to the increasing demand for wireless communication, it  
has become necessary to develop techniques for more  
efficiently using the allocated frequency bands, i.e.  
increasing the capacity to communicate information within a  
25 limited available bandwidth. This increased capacity can be  
used to enhance system performance by increasing the number of  
information channels, by increasing the channel information  
rates and/or by increasing the channel reliability.

30

FIG. 1 shows a conventional low capacity wireless  
communication system. Information is transmitted from a base  
station B to subscribers  $S_1, \dots, S_9$  by broadcasting  
omnidirectional signals on one of several predetermined  
frequency channels. Similarly, the subscribers transmit  
35 information back to the base station by broadcasting similar  
signals on one of the frequency channels. In this system,  
multiple users independently access the system through the

division of the frequency band into distinct subband frequency channels. This technique is known as frequency division multiple access (FDMA).

5 A standard technique used by commercial wireless phone systems to increasing capacity is to divide the service region into spatial cells, as shown in FIG. 2. Instead of using just one base station to serve all users in the region, a collection of base stations  $B_1, \dots, B_7$  are used to independently service  
10 separate spatial cells. In such a cellular system, multiple users can reuse the same frequency channel without interfering with each other, provided they access the system from different spatial cells. The cellular concept, therefore, is a simple type of spatial division multiple access (SDMA).

15 In the case of digital communication, additional techniques can be used to increase capacity. A few well known examples are time division multiple access (TDMA) and code division multiple access (CDMA). TDMA allows several users to share a  
20 single frequency channel by assigning their data to distinct time slots. CDMA is normally a spread-spectrum technique that does not limit individual signals to narrow frequency channels but spreads them throughout the frequency spectrum of the entire band. Signals sharing the band are distinguished by  
25 assigning them different orthogonal digital code sequences. These techniques use digital coding to make more efficient use of the available spectrum.

30 Wireless systems may also use combinations of the above techniques to increase capacity, e.g. FDMA/CDMA and TDMA/CDMA. Although these and other known techniques increase the capacity of wireless communication systems, there is still a need to further increase system performance. Recently, considerable attention has focused on ways to increasing  
35 capacity by further exploiting the spatial domain.

One well-known SDMA technique is to provide the base station with a set of independently controlled directional antennas, thereby dividing the cell into separate sectors, each controlled by a separate antenna. As a result, the frequency reuse in the system can be increased and/or cochannel interference can be reduced. Instead of independently controlled directional antennas, this technique can also be implemented with a coherently controlled antenna array, as shown in FIG. 3. Using a signal processor to control the relative phases of the signals applied to the antenna elements, predetermined beams can be formed in the directions of the separate sectors. Similar signal processing can be used to selectively receive signals only from within the distinct sectors.

In an environment containing a significant number of reflectors (such as buildings), a signal will often follow multiple paths. Because multipath reflections alter the signal directions, the cell space experiences angular mixing and can not be sharply divided into distinct sectors. Multipath can therefore cause cochannel interference between sectors, reducing the benefit of sectoring the cell. In addition, because the separate parts of such a multipath signal can arrive with different phases that destructively interfere, multipath can result in unpredictable signal fading.

In order to avoid the above problems with multipath, more sophisticated SDMA techniques have been proposed. For example, U.S. Pat. No. 5,471,647 and U.S. Pat. No. 5,634,199, both to Gerlach et al., and U.S. Pat. No. 5,592,490 to Barratt et al. disclose wireless communication systems that increase performance by exploiting the spatial domain. In the downlink, the base station determines the spatial channel of each subscriber and uses this channel information to adaptively control its antenna array to form customized beams, as shown in FIG. 4A. These beams transmit an information

signal  $x$  over multiple paths so that the signal  $x$  arrives to the subscriber with maximum strength. The beams can also be selected to direct nulls to other subscribers so that cochannel interference is reduced. In the uplink, as shown in  
5 FIG. 4B, the base station uses the channel information to spatially filter the received signals so that the transmitted signal  $x'$  is received with maximum sensitivity and distinguished from the signals transmitted by other subscribers. In this approach the same information signal  
10 follows several paths, providing increased spatial redundancy.

In the uplink, there are well known signal processing techniques for estimating the spatial channel from the signals received at the base station antenna array, e.g. by using a  
15 *a priori* spatial or temporal structures present in the signal, or by blind adaptive estimation. If the uplink and downlink frequencies are the same, then the spatial channel for the downlink is directly related to the spatial channel for the uplink, and the base can use the known uplink channel  
20 information to perform transmit beamforming in the downlink. Because the spatial channel is frequency dependent and the uplink and downlink frequencies are often different, the base does not always have sufficient information to derive the downlink spatial channel information. One technique for  
25 obtaining downlink channel information is for the subscriber to periodically transmit test signals to the base on the downlink frequency rather than the uplink frequency. Another technique is for the base to transmit test signals and for the subscriber to feedback channel information to the base. If  
30 the spatial channel is quickly changing due to the relative movement of the base, the subscriber and/or reflectors in the environment, then the spatial channel must be updated frequently, placing a heavy demand on the system. One method to reduce the required feedback rates is to track only the  
35 subspace spanned by the time-averaged channel vector, rather than the instantaneous channel vector. Even with this

reduction, however, the required feedback rates are still a large fraction of the signal information rate.

5 Although these adaptive beamforming techniques require substantial signal processing and/or large feedback rates to determine the spatial channel in real time, these techniques have the advantage that they can navigate the complex spatial environment and avoid, to some extent, the problems introduced by multipath reflections. As a result, an increase in performance is enjoyed by adaptive antenna array systems, due to their use of the spatial dimension. Note, however, that while the base station antenna array can make efficient use of the spatial dimension by selectively directing the downlink signal to the subscriber S, the uplink signal in these systems is spatially inefficient. Typically, the subscriber is equipped with only a single antenna that radiates signal energy in all directions, potentially causing cochannel interference. These communication systems, therefore, do not make optimal use of the spatial dimension to increase capacity.

#### OBJECTS AND ADVANTAGES OF THE INVENTION

Accordingly, it is a primary object of the present invention to provide a communication system that significantly increases the capacity and performance of wireless communication systems by taking maximum advantage of the spatial domain. Another object of the invention is to provide computationally efficient coding techniques that make optimal use of the spatial dimensions of the channel. These and other objects and advantages will become apparent from the following description and associated drawings.

#### SUMMARY OF THE INVENTION

35 These objects and advantages are attained by a method of digital wireless communication that takes maximal advantage of spatial channel dimensions between a base station and a subscriber unit to increase system capacity and performance.



Surprisingly, the techniques of the present invention provide an increased information capacity in multipath environments. In contrast, known techniques suffer in the presence of multipath and do not exploit multipath to directly increase system capacity. In brief, the present invention teaches a method of wireless communication using antenna arrays at both the base and subscriber units to transmit distinct information signals over different spatial channels in parallel, thereby multiplying the capacity between the base and the subscriber. The present invention also teaches specific spatio-temporal coding techniques that make optimal use of these additional spatial subchannels.

Generally, the present invention provides a method of digital wireless communication between a base station and a subscriber unit, where a spatial channel characterized by a channel matrix  $\mathbf{H}$  couples an array of  $M_T$  antenna elements at the base station with an array of  $M_R$  antenna elements at the subscriber unit. The method comprises the step of determining from the channel matrix  $\mathbf{H}$  a number  $L$  of independent spatial subchannels, and encoding a plurality of information signals into a sequence of transmitted signal vectors. The transmitted signal vectors have  $M_T$  complex valued components and are selected to distribute distinct signal information over the independent spatial subchannels. The sequence of transmitted signal vectors is transmitted from the array of  $M_T$  antenna elements at the base station, and a sequence of received signal vectors is received at the array of  $M_R$  antenna elements at the subscriber unit. The received signal vectors have  $M_R$  complex valued components. These received signal vectors are decoded to yield the information signals.

In another aspect, the invention provides a method that comprises computing from a set of  $K$  original information signals a spatio-temporal coded signal in accordance with a channel matrix  $\mathbf{H}$ . The channel matrix  $\mathbf{H}$  represents the spatio-temporal characteristics of the information link between a

base station array of  $M_T$  antenna elements and a subscriber unit array of  $M_R$  antenna elements. Signal processing techniques are used to decompose  $\mathbf{H}$  into  $K$  parallel spatio-temporal subchannels that can independently carry information signals between the base and subscriber units. After transmitting the spatio-temporal coded signal over the channel, it is decoded into a set of  $K$  received information signals that correspond to the  $K$  original information signals. In a preferred embodiment, the  $K$  parallel spatio-temporal subchannels are characterized by a set of  $K$  spatio-temporal transmission sequences that are derived from a decomposition of  $\mathbf{H}$  into independent modes, and a set of  $K$  corresponding receive sequences. For example, the  $K$  spatio-temporal transmission sequences may be multiples of right singular vectors of  $\mathbf{H}$ , and the receive sequences may be a matched set of  $K$  spatio-temporal filter sequences that are left singular vectors of  $\mathbf{H}$ .

If  $L$  is the number of multipath components between the base station and the subscriber unit, then the number  $K$  of parallel spatio-temporal channels is not more than  $(N+v) \times M_R$ , not more than  $N \times M_T$ , and not more than  $N \times L$ , where  $(N+v)$  is a maximum number of nonzero output samples transmitted for a block of  $N$  symbols. In a preferred embodiment, the original information signals comprise  $K$  blocks of  $N$  symbols, and the channel matrix  $\mathbf{H}$  comprises  $M_T \times M_R$  blocks of  $N \times (N+v)$  channel matrices  $\mathbf{H}_{ij}$ .

In some applications of the present invention, the channel state information (CSI) may not be completely known, or may be expensive to compute. Accordingly, the present invention also provides a method for facilitating the efficient computation of the  $K$  received information signals from the transmitted spatio-temporal coded signal by adding cyclic prefixes to the coded signal prior to transmission.

35

**DESCRIPTION OF THE FIGURES**

FIG. 1 shows a low capacity wireless communication system well known in the prior art.

5 FIG. 2 illustrates a known technique of spatially dividing a service region into cells in order to increase system capacity.

FIG. 3 illustrates the use of beamforming with an antenna array to divide a cell into angular sectors, as is known in the art.

10 FIGS. 4A and 4B illustrate state-of-the-art techniques using adaptive antenna arrays for downlink and uplink beamforming, respectively.

15 FIGS. 5A and 5B show the parallel transmission of distinct information signals using spatial subchannels in downlink and uplink, respectively, as taught by the present invention.

20 FIGS. 6A and 6B are physical and schematic representations, respectively, of a communication channel for a system with multiple transmitting antennas and multiple receiving antennas, according to the present invention.

FIG. 7 is a block diagram of the system architecture for communicating information over a multiple-input-multiple-output spatial channel according to the present invention.

25

**DETAILED DESCRIPTION**

Although the following detailed description contains many specifics for the purposes of illustration, anyone of ordinary skill in the art will appreciate that many variations and alterations to the following details are within the scope of the invention. Accordingly, the following preferred embodiment of the invention is set forth without any loss of generality to, and without imposing limitations upon, the claimed invention.

35

As discussed above in relation to FIGS. 4A and 4B, prior art wireless systems employing an adaptive antenna array at the

base station are multiple-input-single-output (MISO) systems, i.e. the channel from the base to the subscriber is characterized by multiple inputs at the transmitting antenna array and a single output at the receiving subscriber antenna.

5 Because these MISO systems can exploit some of the spatial channel, they have an increased capacity as compared to single-input-single-output (SISO) systems that are discussed above in relation to FIGS. 1 and 2. It should be noted that although the MISO systems disclosed in the prior art provide

10 an increase in overall system capacity by spatially isolating separate subscribers from each other, these systems do not provide an increase in the capacity of information transmitted from the base to a single subscriber, or vice versa. As shown in FIGS. 4A and 4B, only one information signal is transmitted

15 between the base and subscriber in both downlink and uplink of a MISO system. Even in the case where the subscriber is provided with an antenna array, the prior art suggests only that this capability would further reduce cochannel interference. Although the overall system capacity could be

20 increased, this would not increase the capacity between the base and a single subscriber.

The present invention, in contrast, is a multiple-input-multiple-output (MIMO) wireless communication system that is distinguished by the fact that it increases the capacity of

25 both uplink and downlink transmissions between a base and a subscriber through a novel use of additional spatial channel dimensions. The present inventors have recognized the possibility of exploiting multiple parallel spatial

30 subchannels between a base station and a subscriber, thereby making use of additional spatial dimensions to increase the capacity of wireless communication. Surprisingly, this technique provides an increased information capacity and performance in multipath environments, a result that is in

35 striking contrast with conventional wisdom.

FIGS. 5A and 5B illustrate a MIMO wireless communication system according to the present invention. As shown in FIG. 5A, a base station B uses adaptive antenna arrays and spatial processing to transmit distinct downlink signals  $x_1$ ,  $x_2$ ,  $x_3$  through separate spatial subchannels to a subscriber unit S which uses an adaptive array and spatial processing to receive the separate signals. In a similar manner, the subscriber S uses an adaptive array to transmit distinct uplink signals  $x'_1$ ,  $x'_2$ ,  $x'_3$  to the base B over the same spatial subchannels. As the multipath in the environment increases, the channel acquires a richer spatial structure that allows more subchannels to be used for increased capacity.

It is important to note that the simple assignment of the distinct signals to the distinct spatial paths in a one-to-one correspondence, as illustrated above, is only one possible way to exploit the additional capacity provided by the spatial subchannel structure. For example, coding techniques can be used to mix the signal information among the various paths. In addition, the present inventors have developed techniques for coupling these additional spatial dimensions to available temporal and/or frequency dimensions prior to transmission. Although such coupled spatio-temporal coding techniques are more subtle than direct spatial coding alone, they provide better system performance, as will be described in detail below.

In order to facilitate an understanding of the present invention and enable those skilled in the art to practice it, the following description includes a teaching of the general principles of the invention, as well as implementation details. First we develop a compact model for understanding frequency dispersive, spatially selective wireless MIMO channels. We then discuss their theoretical information capacity limits, and propose spatio-temporal coding structures that asymptotically achieve theoretical channel capacity. In particular, a spatio-temporal vector coding (STVC) structure

for burst transmission is disclosed, as well as a more practical, reduced complexity, discrete matrix multitone (DMMT) space-frequency coding structure. Both STVC and DMMT are shown to achieve the theoretical channel capacity as the  
5 burst duration increases.

In its preferred implementations, the present invention makes use of many techniques and devices well known in the art of adaptive antenna arrays systems and associated digital  
10 beamforming signal processing. These techniques and devices are described in detail in U.S. Pat. No. 5,471,647 and U.S. Pat. No. 5,634,199, both to Gerlach et al., and U.S. Pat. No. 5,592,490 to Barratt et al., which are all incorporated herein by reference. In addition, a comprehensive treatment of the  
15 present state of the art is given by John Livita and Titus Kwok-Yeung Lo in *Digital Beamforming in Wireless Communications* (Artech House Publishers, 1996). Accordingly, the following detailed description focuses upon the specific signal processing techniques which are required to enable  
20 those skilled in the art to practice the present invention.

Consider a communication channel for a system with  $M_T$  transmitting antennas at a base B and  $M_R$  receiving antennas at a subscriber S, as illustrated in FIGS. 6A and 6B. The  
25 channel input at a sample time k can be represented by an  $M_T$  dimensional column vector

$$\mathbf{z}(k) = [z_1(k), \dots, z_{M_T}(k)]^T,$$

30 and the channel output and noise for sample k can be represented, respectively, by  $M_R$  dimensional column vectors

$$\mathbf{x}(k) = [x_1(k), \dots, x_{M_R}(k)]^T,$$

and

35  $\mathbf{n}(k) = [n_1(k), \dots, n_{M_R}(k)]^T.$

The communication over the channel  $\mathbf{H}$  may then be expressed as a vector equation

$$\mathbf{x}(k) = \mathbf{H}\mathbf{z}(k) + \mathbf{n}(k),$$

5

where the MIMO channel matrix is

$$\mathbf{H} = \begin{pmatrix} h_{1,1} & \dots & h_{1,M_T} \\ \vdots & & \vdots \\ h_{M_R,1} & \dots & h_{M_R,M_T} \end{pmatrix}.$$

10 Each matrix element  $h_{ij}$  represents the SISO channel between the  $i^{\text{th}}$  receiver antenna and the  $j^{\text{th}}$  transmitter antenna. Due to the multipath structure of the spatial channel, orthogonal spatial subchannels can be determined by calculating the independent modes (e.g. eigenvectors) of the channel matrix  $\mathbf{H}$ .  
 15 These spatial subchannels can then be used to transmit independent signals and increase the capacity of the communication link between the base B and the subscriber S. Because the multipath introduces time delays, however, a spatial decomposition alone will result in temporal mixing of  
 20 the signals. It is more appropriate, therefore, to perform a more general spatio-temporal analysis of the channel.

Let  $\{z_j(n)\}$  be a digital symbol sequence to be transmitted from the  $j^{\text{th}}$  antenna element,  $g(t)$  a pulse shaping function  
 25 impulse response, and  $T$  the symbol period. Then the signal applied to the  $j^{\text{th}}$  antenna element at time  $t$  is given by

$$s_j(t) = \sum_n z_j(n)g(t-nT)$$

30 The pulse shaping function is typically the convolution of two separate filters, one at the transmitter and one at the receiver. The optimum receiver filter is a matched filter. In practice, the pulse shape is windowed resulting in a finite duration impulse response. We assume synchronous complex  
 35 baseband sampling with symbol period  $T$ . We define  $n_0$  and  $(v+1)$

to be the maximum lag and length over all paths  $l$  for the windowed pulse function sequences  $\{g(nT - \tau_l)\}$ . To simplify notation, it is assumed that  $n_0 = 0$ , and the discrete-time notation  $g(nT - \tau_l) = g_l(n)$  is adopted.

5

When a block of  $N$  data symbols are transmitted,  $N+v$  non-zero output samples result beginning at time sample  $k-N+1$  and ending with sample  $k+v$ . The composite channel output can now be written as an  $M_R N(N+v)$  dimensional column vector with all time samples for a given receive antenna appearing in order so that

10

$$\mathbf{x}(k) = [x_1(k-N+1), \dots, x_1(k+v), \dots, x_{M_R}(k-N+1), \dots, x_{M_R}(k+v)]^T,$$

15

with an identical stacking for the output noise samples  $\mathbf{n}(k)$ . Similarly, the channel input is an  $M_T N$  dimensional column vector written as

$$\mathbf{z}(k) = [z_1(k-N+1), \dots, z_1(k), \dots, z_{M_T}(k-N+1), \dots, z_{M_T}(k)]^T,$$

20

The spatio-temporal communication over the channel  $\mathbf{H}$  may then be expressed as a vector equation

$$\mathbf{x}(k) = \mathbf{H}\mathbf{z}(k) + \mathbf{n}(k),$$

25

where the MIMO channel matrix

$$\mathbf{H} = \begin{pmatrix} \mathbf{H}_{1,1} & \dots & \mathbf{H}_{1,M_T} \\ \vdots & & \vdots \\ \mathbf{H}_{M_R,1} & \dots & \mathbf{H}_{M_R,M_T} \end{pmatrix}$$

30

is composed of SISO sub-blocks  $\mathbf{H}_{ij}$  with each sub-block possessing the well known Toeplitz form.

35

We will now discuss the information capacity for the spatio-temporal channel developed above. The following analysis assumes that the noise  $\mathbf{n}(k)$  is additive white Gaussian noise (AWGN) with covariance  $\sigma^2 \mathbf{I}$ . Each channel use consists of an  $N$



symbol burst transmission and the total average power radiated from all antennas and all time samples is constrained to less than a constant.

- 5 Write the singular value decomposition (SVD) of the channel matrix as  $\mathbf{H}=\mathbf{V}_H\Lambda_H\mathbf{U}_H^*$ , with the  $j^{\text{th}}$  singular value denoted  $\lambda_{H,j}$ . Write the spatio-temporal covariance matrix for  $\mathbf{z}(k)$  as  $\mathbf{R}_z$  with eigenvalue decomposition  $\mathbf{R}_z=\mathbf{V}_z\Lambda_z\mathbf{U}_z^*$ , and eigenvalues  $\lambda_{z,j}$ .
- 10 It can be demonstrated that the information capacity for the discrete-time spatio-temporal communication channel defined above is given by

$$C = \sum_{n=1}^{N\mathbf{N}M_T} \log \left( 1 + \frac{\lambda_{z,n} |\lambda_{H,n}|^2}{\sigma^2} \right),$$

- 15 where  $\lambda_{z,n}$  is given by the spatio-temporal water-filling solution. Motivated by this result, the inventors devised the following temporal vector coding technique. By appropriately selecting up to  $N\mathbf{N}M_T$  spatio-temporal transmission vectors that
- 20 are multiples of the right singular vectors of  $\mathbf{H}$ , and receiving with up to  $N\mathbf{N}M_T$  matched spatio-temporal filter vectors that are the left singular vectors of  $\mathbf{H}$ , up to  $N\mathbf{N}M_T$  parallel spatio-temporal subchannels are constructed for communicating information over the channel. Mathematically,
- 25 this STVC channel is derived as follows. Substituting  $\mathbf{H}=\mathbf{V}_H\Lambda_H\mathbf{U}_H^*$  into the original equation  $\mathbf{x}(k)=\mathbf{H}\mathbf{z}(k)+\mathbf{n}(k)$  for the channel gives

$$\mathbf{x}(k) = \mathbf{V}_H\Lambda_H\mathbf{U}_H^*\mathbf{z}(k) + \mathbf{n}(k),$$

- 30 Left multiplication by  $\mathbf{V}_H^*$  yields

$$\mathbf{V}_H^*\mathbf{x}(k) = \Lambda_H\mathbf{U}_H^*\mathbf{z}(k) + \mathbf{V}_H^*\mathbf{n}(k),$$

- 35 which yields the STVC channel when rewritten as

$$\hat{\mathbf{x}}(k) = \Lambda_H \hat{\mathbf{z}}(k) + \hat{\mathbf{n}}(k),$$

where  $\hat{\mathbf{z}}(k) = \mathbf{U}_H^* \mathbf{z}(k)$ ,  $\hat{\mathbf{x}}(k) = \mathbf{V}_H^* \mathbf{x}(k)$  and  $\hat{\mathbf{n}}(k) = \mathbf{V}_H^* \mathbf{n}(k)$ .

5

By analyzing the ranks of the above matrices, it can be demonstrated that the maximum number of finite amplitude parallel spatio-temporal channel dimensions,  $K$ , that can be created to communicate over the far field channel defined above is equal to  $\min \{ NNL, (N+V)NM_R, NNM \}$ , where  $L$  is the number of multipath components. Thus, multipath is an advantage in far-field MIMO channels. If the multipath is large ( $L \gg 1$ ), the capacity can be multiplied by adding antennas to both sides of the radio link. This capacity improvement occurs with no penalty in average radiated power or frequency bandwidth because the number of parallel channel dimensions is increased. In practice, an adaptive antenna array base station, such as that described by Barratt et al., is modified to implement the above vector coding scheme. In particular, a signal processor is designed to perform a spatio-temporal transform of information signals in accordance with the above equations so that they may be transmitted through the independent parallel subchannels and decoded by the subscriber.

25

The space-time vector coding solution described above requires a computation of the singular value decomposition of an  $(N+V)NM_R \times NNM_T$  matrix. Since this computation can be complex, the present inventors have developed an optimal space-time communication structure that requires less computational complexity to implement. In particular, complexity can be reduced by using a coding structure similar to the discrete multi-tone (DMT) standard. DMT is in widespread use for wired SISO channels. DMT has also been applied to wired MISO channels, as described in U.S. Pat. No. 5,625,651 which is hereby incorporated by reference. The present inventors have generalized DMT to the MIMO case and

35

adapted it to wireless channels to obtain a novel space-frequency coding structure that results in a matrix of transmission and reception vector solutions for each discrete Fourier transform (DFT) frequency index. Because this new coding scheme has been generalized to MIMO channels characterized by a channel matrix, it is called discrete matrix multi-tone (DMMT).

In DMMT, N data symbols are again transmitted during each channel usage. However, a cyclic prefix is added to the data so that the last v data symbols are transmitted from each antenna element prior to transmitting the full block of N symbols. By receiving only N time samples at the output of each antenna element, ignoring the first and last v output samples, the MIMO channel submatrices  $\hat{\mathbf{H}}_{ij}$  now appear as cyclic structures:

$$\hat{\mathbf{H}}_{i,j} = \begin{pmatrix} h(v) & \dots & h(0) & 0 & 0 & \dots & 0 & 0 & 0 & 0 \\ 0 & h(v) & & h(0) & 0 & \dots & 0 & 0 & 0 & 0 \\ \vdots & & & & \vdots & \vdots & & & & \vdots \\ 0 & & & & 0 & \dots & 0 & & & 0 \\ 0 & \dots & 0 & 0 & 0 & \dots & 0 & h(v) & \dots & h(0) \\ & & & \vdots & \vdots & & \vdots & & & \vdots \\ h(v-1) & \dots & h(0) & 0 & 0 & \dots & 0 & \dots & 0 & h(v) \end{pmatrix}$$

Given the cyclic SISO channel blocks, the channel matrix can be diagonalized with a relatively simple three step procedure. First post multiply  $\hat{\mathbf{H}}$  with the  $NM_T \times NM_T$  block diagonal inverse discrete Fourier transform (IDFT) matrix  $\mathbf{F}^{*(M_T)}$  where each diagonal block is the unitary  $N \times N$  IDFT matrix  $\mathbf{F}^*$ . The next step is to premultiply  $\hat{\mathbf{H}}$  by a similar  $NM_R \times NM_R$  block diagonal DFT matrix  $\mathbf{F}^{(M_R)}$  where the diagonal submatrices  $\mathbf{F}$  are  $N \times N$  DFT matrices. With the well known result that the discrete Fourier transform basis vectors form the orthonormal singular vectors of the cyclic matrices  $\hat{\mathbf{H}}_{ij}$ , the new channel

matrix resulting from the IDFT post multiplication and the DFT premultiplication is

$$5 \quad \mathbf{F}^{(M_R)} \hat{\mathbf{H}} \mathbf{F}^{*(M_T)} = \begin{pmatrix} \Gamma_{1,1} \cdots \Gamma_{1,M_T} \\ \vdots \quad \quad \quad \vdots \\ \Gamma_{M_R,1} \cdots \Gamma_{M_R,M_T} \end{pmatrix}$$

where  $\Gamma_{i,j}$  is the diagonal matrix containing the singular values  $\gamma_{i,j,n}$  of the cyclic channel submatrix  $\hat{\mathbf{H}}_{ij}$ . Premultiplication and postmultiplication by a permutation matrix  $\mathbf{P}$  yields the block diagonal matrix

$$15 \quad \mathbf{P} \mathbf{F}^{(M_R)} \hat{\mathbf{H}} \mathbf{F}^{*(M_T)} \mathbf{P} = \begin{pmatrix} \mathbf{B}_1 & 0 \\ & \mathbf{N} \\ 0 & \mathbf{B}_N \end{pmatrix}$$

where

$$\mathbf{B}_n = \begin{pmatrix} \gamma_{1,1,n} \cdots \gamma_{1,M_T,n} \\ \vdots \quad \quad \quad \vdots \\ \gamma_{M_R,1,n} \cdots \gamma_{M_R,M_T,n} \end{pmatrix}$$

20 is the  $M_R \times M_T$  space-frequency channel evaluated at DFT index  $n$ . Given the SVD of  $\mathbf{B}_n = \mathbf{V}_{B,n} \Lambda_{B,n} \mathbf{U}_{B,n}^*$ , the diagonal DMMT channel matrix  $\hat{\mathbf{H}}$  is finally obtained by post multiplying by  $\mathbf{U}_B^{(M_T)}$  and premultiplying by  $\mathbf{V}_B^{*(M_R)}$  to obtain

$$25 \quad \Lambda_{\hat{\mathbf{H}}} = \mathbf{V}_B^{*(M_R)} \mathbf{P} \mathbf{F}^{(M_R)} \hat{\mathbf{H}} \mathbf{F}^{*(M_T)} \mathbf{P} \mathbf{U}_B^{(M_T)} = \begin{pmatrix} \Lambda_{\hat{\mathbf{H}},1} & 0 \\ & \mathbf{N} \\ 0 & \Lambda_{\hat{\mathbf{H}},N} \end{pmatrix}$$

where  $\mathbf{U}_B^{(M_T)}$  is block diagonal containing the right singular matrices of the  $\mathbf{B}_n$  matrices,  $\mathbf{V}_B^{*(M_R)}$  is block diagonal containing the left singular matrices of the  $\mathbf{B}_n$  matrices, and each of the diagonal submatrices  $\Lambda_{\hat{\mathbf{H}},n}$  contains the DMMT spatial sub-channel amplitudes,  $\lambda_{\hat{\mathbf{H}},n,j}$  for DFT bin  $n$ . The parallel channel DMMT equation is then

$$\hat{\mathbf{x}}(k) = \Lambda_{\hat{\mathbf{H}}}\hat{\mathbf{z}}(k) + \hat{\mathbf{n}}(k),$$

5 where  $\mathbf{z}(k)$  is the dimension  $NM_T$  input symbol vector,  $\hat{\mathbf{x}}(k)$  is the dimension  $NM_R$  output symbol vector, and  $\hat{\mathbf{n}}(k)$  is the dimension  $NM_R$  equivalent output noise vector after the DFT and spatial orthogonalization operations are performed. A block diagram architecture that implements this DMMT space-frequency channel decomposition is presented in FIG. 7. The left portion of the diagram corresponds to the application of the operators  $\mathbf{F}^{*(M_T)}\mathbf{P}\mathbf{U}_B^{(M_T)}$  on the signal  $\hat{\mathbf{z}}(k)$ . These operations are performed by a signal processor at the transmitter. The right portion of the diagram corresponds to the application of the operators  $\mathbf{V}_B^{*(M_R)}\mathbf{P}\mathbf{F}^{(M_R)}$  on the received signals to recover a received information signal  $\hat{\mathbf{x}}(k)$ . These operations are performed by a signal processor at the receiver. The central matrix  $\hat{\mathbf{H}}$  corresponds to the spatial channel itself. By construction, the signal processing operations result in a direct relationship between the received and transmitted information signals, as indicated by the fact that the matrix  $\Lambda_{\hat{\mathbf{H}}}$  in the parallel channel DMMT equation is diagonal.

25 This coding scheme significantly reduces the signal processing complexity required at the transmitter and receiver to diagonalize all space-time subchannels for each data block. In particular, this asymptotically optimal space-frequency MIMO DMMT information transmission technique has a complexity advantage of approximately  $N^2$  as compared to the vector coding case. Moreover, since all of the matrix operations involved in creating the diagonal DMMT channel are invertible, the capacity of the DMMT channel is unchanged from that of the original cyclic sub-block matrix  $\hat{\mathbf{H}}$ . Thus, compared to STVC, the only capacity decrease for the DMMT space-time coding solution is due to the radiated power penalty required to transmit the cyclic prefix. This capacity penalty, however,

becomes small for large  $N$ . Thus, this new communications structure offers the advantage of very large increases in capacity without penalty in total average transmitted power or bandwidth.

5

In order to perform transmit beamforming, the base station signal processor computes spatio-temporal downlink subchannel information from downlink channel information fed back from the subscriber. The downlink signal information is then  
10 encoded in accordance with this computed downlink subchannel information. Similarly, the subscriber performs the same functions for the uplink channel using information fed back from the base. Because the present invention provides techniques for efficient channel estimation and increased  
15 channel capacity, the base and subscriber can both quickly estimate the channel and exchange channel information over the increased capacity channels, possibly at a rate slower than that of information data. As a result, both the base and subscriber can maintain a high degree of spatial resolution in  
20 transmit beamforming, thereby significantly reducing cochannel interference from other base stations or subscribers. As a result of this high degree of spatial discrimination in both transmission and reception, many more base stations and subscribers can share the same region of space while using the  
25 same frequency channel. Consequently, in addition to increasing the capacity of the channel between any two arrays, the present invention also increases system wide capacity by significantly reducing cochannel interference.

30 The teaching contained in this description can easily be extended to channels where the noise is not white but is highly structured as in the case of additive co-channel interference. In this case, large gains in cellular network capacity result from the ability to null interference at the  
35 receiver and the ability to constrain radiated interference power at the transmitter. These spatial coding techniques can also be applied to single frequency subchannel systems with

flat fading, conventional analog multicarrier transmission channels, or CDMA channels where each code delay can be decomposed into orthogonal subchannels provided that there is sub-chip multipath. The concepts of the present invention can also be applied to a more general class of channels where the antenna array is distributed over large distances and the propagation does not follow far field behavior. Finally, other communication media such as wire-line, acoustic media, and optical media will experience the same basic communication system benefits when spatio-temporal MIMO channel structures are employed. Thus, it will be clear to one skilled in the art that the above embodiment may be altered in many ways without departing from the scope of the invention. Accordingly, the scope of the invention should be determined by the following claims and their legal equivalents.

## CLAIMS

What is claimed is:

- 1 1. A method of digital wireless communication between a base  
2 station and a subscriber unit, the method comprising:  
3 determining from channel information a number  $L$  of independent  
4 spatial subchannels, wherein the channel information  
5 comprises spatial information relating to a spatial  
6 channel coupling an array of  $M_T$  antenna elements at the  
7 base station with an array of  $M_R$  antenna elements at the  
8 subscriber unit;  
9 encoding a plurality of information signals into a sequence of  
10 transmitted signal vectors, wherein the transmitted  
11 signal vectors have  $M_T$  complex valued components and are  
12 selected to send distinct information signal over the  
13 independent spatial subchannels;  
14 transmitting the sequence of transmitted signal vectors from  
15 the array of  $M_T$  antenna elements at the base station;  
16 receiving a sequence of received signal vectors at the array  
17 of  $M_R$  antenna elements at the subscriber unit, wherein  
18 the received signal vectors have  $M_R$  complex valued  
19 components; and  
20 decoding the received signal vectors to recover the  
21 information signals.  
22
- 1 2. The method of claim 1 further comprising transmitting the  
2 channel information from the subscriber to the base.  
3
- 1 3. The method of claim 1 wherein the channel information  
2 comprises a spatio-temporal channel matrix.  
3
- 1 4. The method of claim 1 wherein the number  $L$  of independent  
2 spatial subchannels is equal to the number of multiple  
3 signal paths between the base and the subscriber.  
4
- 1 5. The method of claim 1 wherein the encoding step comprises  
2 scaling the information signals by complex numbers,



3           permuting the scaled information signals and inverse  
4           Fourier transforming the permuted scaled information  
5           signals, and wherein the decoding step comprises Fourier  
6           transforming the received signals, permuting the Fourier  
7           transformed received signals, and scaling the permuted  
8           Fourier transformed received signals.

9  
1       6.    A method of digital wireless communication between a base  
2       station and a subscriber unit, the method comprising:  
3       computing from a set of  $K$  original information signals a  
4       spatio-temporal coded signal in accordance with a channel  
5       matrix  $\mathbf{H}$  having  $K$  parallel spatio-temporal subchannels;  
6       transmitting the spatio-temporal coded signal from a base  
7       station array of  $M_T$  antenna elements through a channel  
8       corresponding to the channel matrix  $\mathbf{H}$  to a subscriber  
9       unit array of  $M_R$  antenna elements; and  
10      computing from the transmitted spatio-temporal coded signal a  
11      set of  $K$  received information signals.

12  
1       7.    The method of claim 6 wherein  $K$  is not more than  
2        $(N+v) \times M_R$ , not more than  $N \times M_T$ , and not more than  
3        $N \times L$ , where  $L$  is a maximum number of multipath  
4       components between the base station and the subscriber  
5       unit, and where  $(N+v)$  is a maximum number of nonzero  
6       output samples transmitted for a block of  $N$  symbols.

7  
1       8.    The method of claim 6 wherein the original information  
2       signals comprise  $K$  blocks of  $N$  symbols, and the channel  
3       matrix  $\mathbf{H}$  comprises  $M_T \times M_R$  blocks of  $N \times (N+v)$  channel  
4       matrices  $\mathbf{H}_{ij}$ , where  $(N+v)$  is a maximum number of nonzero  
5       output samples transmitted for a block of  $N$  symbols.

6  
1       9.    The method of claim 6 wherein cyclic prefixes are added  
2       to the coded signal prior to the transmitting step,  
3       thereby facilitating the efficient computation of the  $K$   
4       received information signals from the transmitted spatio-  
5       temporal coded signal.

6

1 10. The method of claim 6 wherein the K parallel spatio-  
2 temporal subchannels are characterized by a set of K  
3 spatio-temporal transmission sequences that are derived  
4 from a decomposition of  $\mathbf{H}$  into independent modes.

5

1 11. The method of claim 6 wherein the K parallel spatio-  
2 temporal subchannels are characterized by a set of K  
3 spatio-temporal transmission sequences that are multiples  
4 of right singular vectors of  $\mathbf{H}$ , and matched set of K  
5 spatio-temporal filter sequences that are left singular  
6 vectors of  $\mathbf{H}$ .

7

1 12. A digital wireless communication system comprising:  
2 a base station comprising a base station antenna array and a  
3 base station signal processor coupled to the base station  
4 antenna array;  
5 a subscriber unit comprising a subscriber antenna array  
6 coupled through a wireless channel to the base station  
7 antenna array and a subscriber signal processor coupled  
8 to the subscriber antenna array;  
9 wherein the base station signal processor computes spatio-  
10 temporal downlink subchannel information from downlink  
11 channel information received from the subscriber, and  
12 encodes downlink signal information in accordance with  
13 the computed downlink subchannel information; and  
14 wherein the subscriber signal processor computes spatio-  
15 temporal uplink subchannel information from uplink  
16 channel information received from the base station, and  
17 encodes uplink signal information in accordance with the  
18 computed uplink subchannel information.

1/7

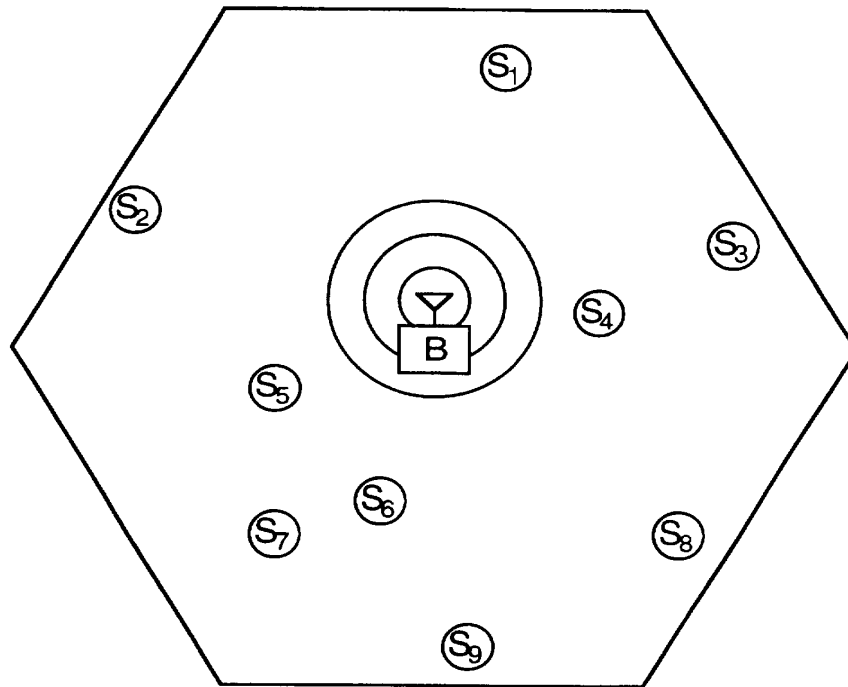


FIG. 1  
(PRIOR ART)

2/7

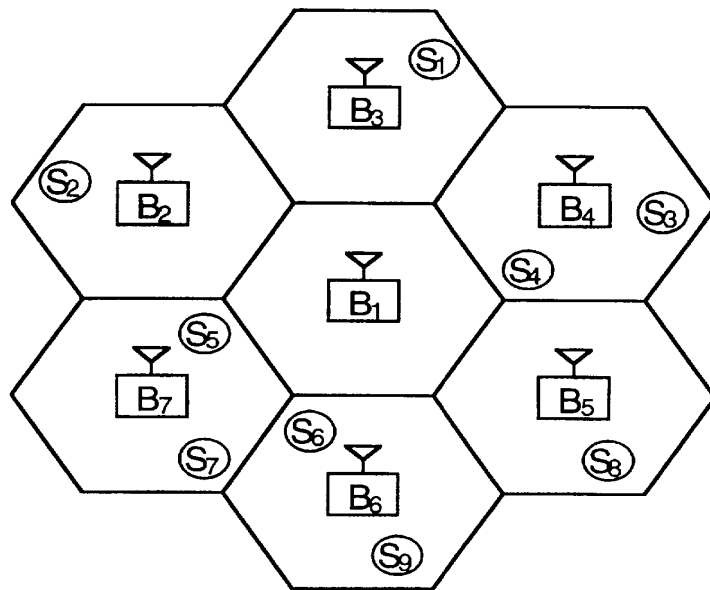


FIG. 2  
(PRIOR ART)

3/7

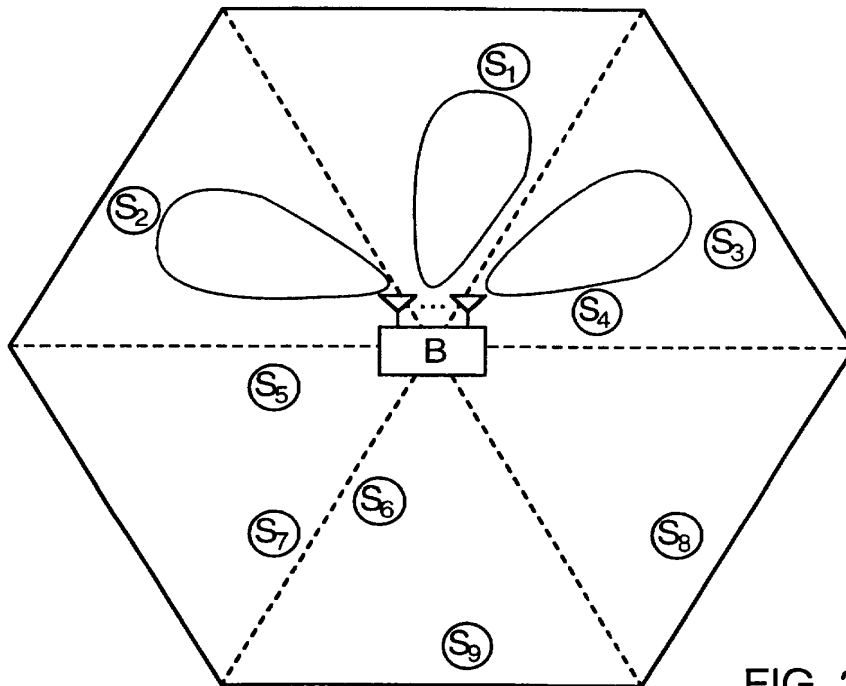


FIG. 3  
(PRIOR ART)

4/7

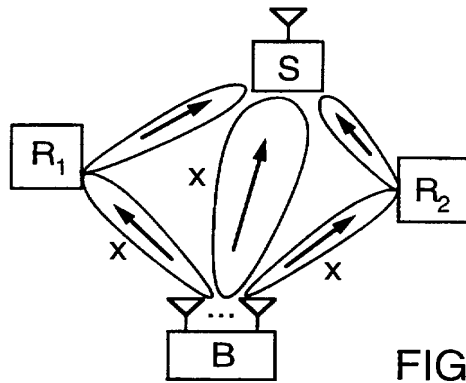


FIG. 4A  
(PRIOR ART)

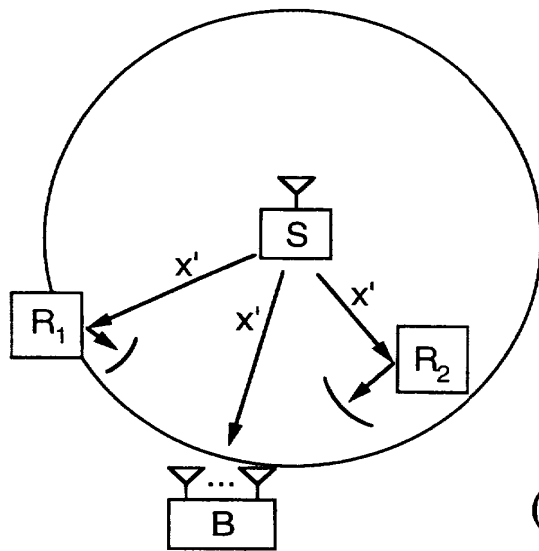


FIG. 4B  
(PRIOR ART)

5/7

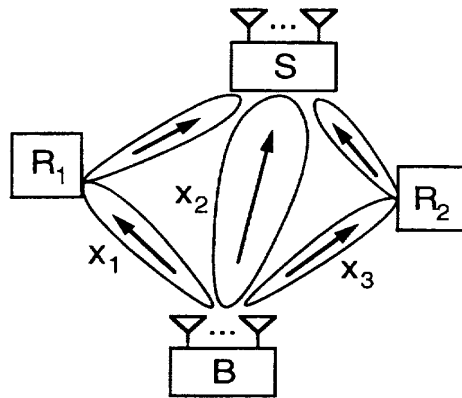


FIG. 5A

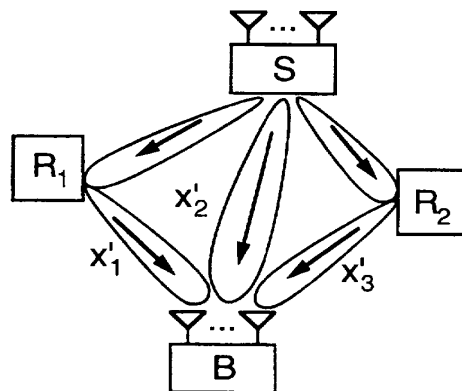


FIG. 5B

6/7

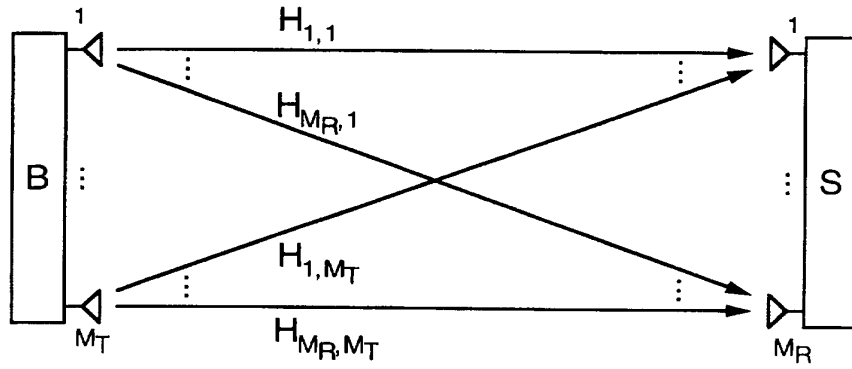


FIG. 6A

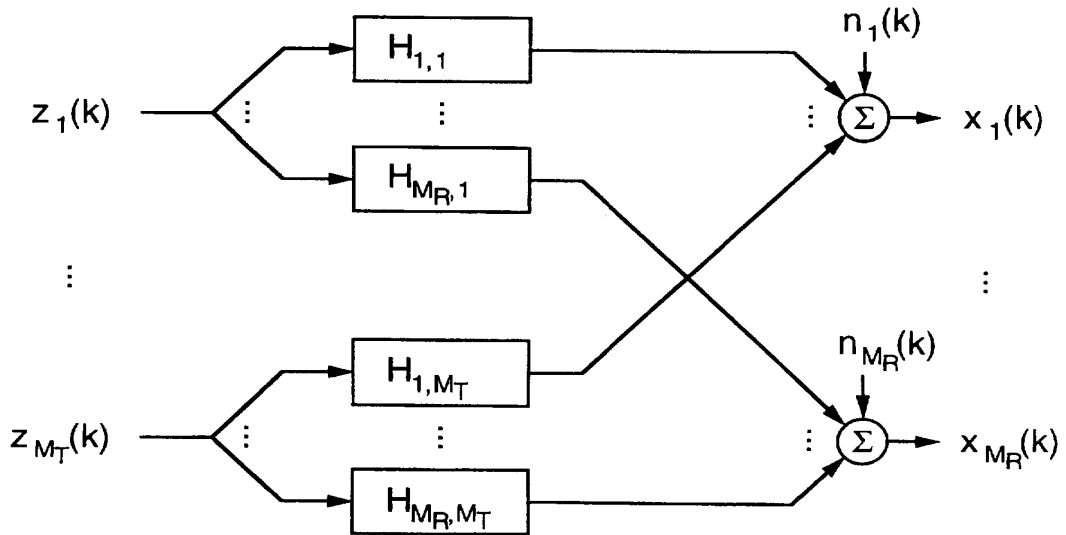


FIG. 6B



7/7

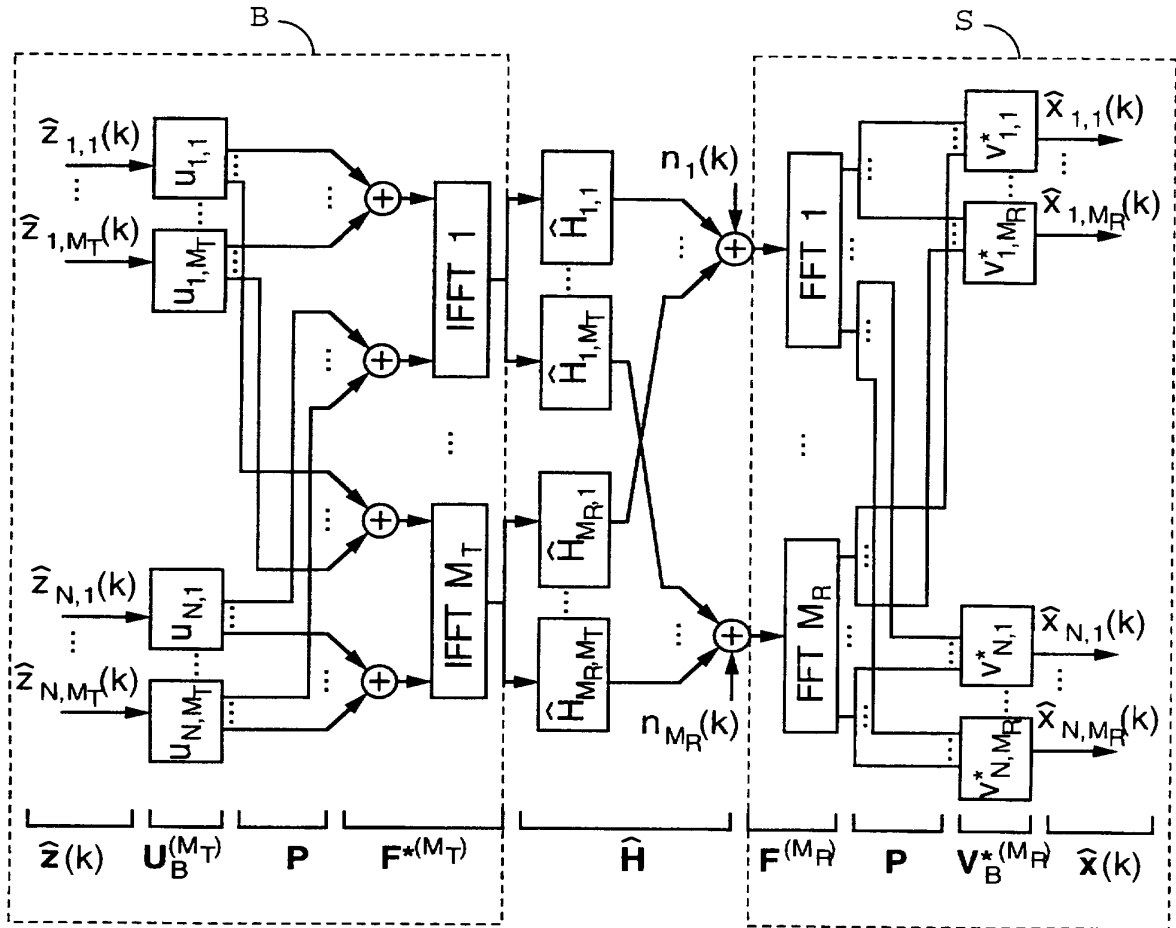


FIG. 7

INTERNATIONAL SEARCH REPORT

International application No.  
PCT/US97/15363

<b>A. CLASSIFICATION OF SUBJECT MATTER</b>														
IPC(6) :H04B 1/38; H04M 1/00 US CL :455/562, 101, 103, 272 According to International Patent Classification (IPC) or to both national classification and IPC														
<b>B. FIELDS SEARCHED</b>														
Minimum documentation searched (classification system followed by classification symbols) U.S. : 455/562, 101, 103, 272, 504, 506, 65, 132; 375/347														
Documentation searched other than minimum documentation to the extent that such documents are included in the fields searched NONE														
Electronic data base consulted during the international search (name of data base and, where practicable, search terms used) NONE														
<b>C. DOCUMENTS CONSIDERED TO BE RELEVANT</b>														
Category*	Citation of document, with indication, where appropriate, of the relevant passages	Relevant to claim No.												
X	US 4,710,944 A (NOSSEN) 01 December 1987, columns 3-8, figures 1 and 5.	1-12												
X	US 5,548,819 A (ROBB) 20 August 1996, columns 10-13, figures 1a-1b.	1-12												
A,P	US 5,649,287 A (FORSEN ET AL) 15 July 1997, figure 5.	1-12												
<input type="checkbox"/> Further documents are listed in the continuation of Box C. <input type="checkbox"/> See patent family annex.														
<table border="0"> <tr> <td>* Special categories of cited documents:</td> <td>*T* later document published after the international filing date or priority date and not in conflict with the application but cited to understand the principle or theory underlying the invention</td> </tr> <tr> <td>*A* document defining the general state of the art which is not considered to be of particular relevance</td> <td>*X* document of particular relevance; the claimed invention cannot be considered novel or cannot be considered to involve an inventive step when the document is taken alone</td> </tr> <tr> <td>*B* earlier document published on or after the international filing date</td> <td>*Y* document of particular relevance; the claimed invention cannot be considered to involve an inventive step when the document is combined with one or more other such documents, such combination being obvious to a person skilled in the art</td> </tr> <tr> <td>*L* document which may throw doubts on priority claim(s) or which is cited to establish the publication date of another citation or other special reason (as specified)</td> <td>*A* document member of the same patent family</td> </tr> <tr> <td>*O* document referring to an oral disclosure, use, exhibition or other means</td> <td></td> </tr> <tr> <td>*P* document published prior to the international filing date but later than the priority date claimed</td> <td></td> </tr> </table>			* Special categories of cited documents:	*T* later document published after the international filing date or priority date and not in conflict with the application but cited to understand the principle or theory underlying the invention	*A* document defining the general state of the art which is not considered to be of particular relevance	*X* document of particular relevance; the claimed invention cannot be considered novel or cannot be considered to involve an inventive step when the document is taken alone	*B* earlier document published on or after the international filing date	*Y* document of particular relevance; the claimed invention cannot be considered to involve an inventive step when the document is combined with one or more other such documents, such combination being obvious to a person skilled in the art	*L* document which may throw doubts on priority claim(s) or which is cited to establish the publication date of another citation or other special reason (as specified)	*A* document member of the same patent family	*O* document referring to an oral disclosure, use, exhibition or other means		*P* document published prior to the international filing date but later than the priority date claimed	
* Special categories of cited documents:	*T* later document published after the international filing date or priority date and not in conflict with the application but cited to understand the principle or theory underlying the invention													
*A* document defining the general state of the art which is not considered to be of particular relevance	*X* document of particular relevance; the claimed invention cannot be considered novel or cannot be considered to involve an inventive step when the document is taken alone													
*B* earlier document published on or after the international filing date	*Y* document of particular relevance; the claimed invention cannot be considered to involve an inventive step when the document is combined with one or more other such documents, such combination being obvious to a person skilled in the art													
*L* document which may throw doubts on priority claim(s) or which is cited to establish the publication date of another citation or other special reason (as specified)	*A* document member of the same patent family													
*O* document referring to an oral disclosure, use, exhibition or other means														
*P* document published prior to the international filing date but later than the priority date claimed														
Date of the actual completion of the international search 09 OCTOBER 1997		Date of mailing of the international search report 11 7 NOV 1997												
Name and mailing address of the ISA/US Commissioner of Patents and Trademarks Box PCT Washington, D.C. 20231 Facsimile No. (703) 305-3230		Authorized officer NGUYEN VO <i>Joni Bell</i> Telephone No. (703) 308-6728												

Form PCT/ISA/210 (second sheet)(July 1992)\*



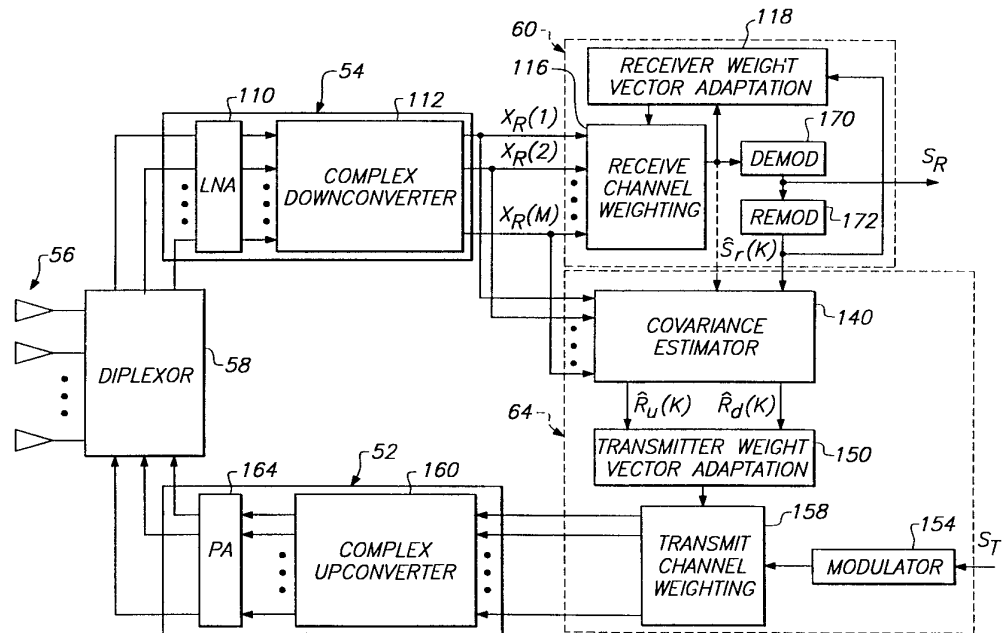
INTERNATIONAL APPLICATION PUBLISHED UNDER THE PATENT COOPERATION TREATY (PCT)

<p>(51) International Patent Classification <sup>6</sup> : <b>H04B 7/04, H01Q 3/26, 25/00, H04Q 7/36, H04B 7/005</b></p>	<p><b>A3</b></p>	<p>(11) International Publication Number: <b>WO 98/18271</b> (43) International Publication Date: 30 April 1998 (30.04.98)</p>
<p>(21) International Application Number: PCT/US97/18196 (22) International Filing Date: 17 October 1997 (17.10.97) (30) Priority Data: 08/735,066 18 October 1996 (18.10.96) US (71) Applicant: WATKINS JOHNSON COMPANY [US/US]; 3333 Hillview Avenue, Palo Alto, CA 94304 (US). (72) Inventor: RALEIGH, Gregory, G.; 539 San Juan Avenue, El Granada, CA 94018 (US). (74) Agents: CHICKERING, Robert, B. et al.; Flehr, Hohbach, Test, Albritton &amp; Herbert LLP, Suite 3400, 4 Embarcadero Center, San Francisco, CA 94111-4187 (US).</p>	<p>(81) Designated States: AL, AM, AT, AU, AZ, BA, BB, BG, BR, BY, CA, CH, CN, CU, CZ, DE, DK, EE, ES, FI, GB, GE, GH, HU, ID, IL, IS, JP, KE, KG, KP, KR, KZ, LC, LK, LR, LS, LT, LU, LV, MD, MG, MK, MN, MW, MX, NO, NZ, PL, PT, RO, RU, SD, SE, SG, SI, SK, SL, TJ, TM, TR, TT, UA, UG, UZ, VN, YU, ZW, ARIPO patent (GH, KE, LS, MW, SD, SZ, UG, ZW), Eurasian patent (AM, AZ, BY, KG, KZ, MD, RU, TJ, TM), European patent (AT, BE, CH, DE, DK, ES, FI, FR, GB, GR, IE, IT, LU, MC, NL, PT, SE), OAPI patent (BF, BI, CF, CG, CI, CM, GA, GN, ML, MR, NE, SN, TD, TG).</p> <p><b>Published</b> <i>With international search report. Before the expiration of the time limit for amending the claims and to be republished in the event of the receipt of amendments.</i></p> <p>(88) Date of publication of the international search report: 6 August 1998 (06.08.98)</p>	

(54) Title: WIRELESS COMMUNICATION NETWORK USING TIME-VARYING VECTOR CHANNEL EQUALIZATION FOR ADAPTIVE SPATIAL EQUALIZATION

(57) Abstract

An adaptive reception and transmission technique according to one embodiment of the invention offers the advantages of adaptive reception transmission using feedback without the associated mobile radio complexity increase and information capacity penalty. The technique has been developed to exploit structured variation which occurs in the multipath fading present in the wireless antenna array channel. Thus, multipath propagation effects are explicitly accounted for in the problem approach. The technique is blind in that the antenna beam is formed in the absence of explicit knowledge of the array geometry, and without the necessity of array calibration or mobile feedback. The basic approach is to estimate to optimum receive and



transmit antenna beam pattern based on certain statistical properties of the received antenna array signals. The optimum receive and transmit beam pattern is found by solving an optimization equation. The adaptive transceiver system is suitable for use in conjunction with either a diplexed transmit/receive antenna array, or with separate transmit and receive arrays.

\* (Referred to in PCT Gazette No. 35/1998, Section II)

**FOR THE PURPOSES OF INFORMATION ONLY**

Codes used to identify States party to the PCT on the front pages of pamphlets publishing international applications under the PCT.

<b>AL</b>	Albania	<b>ES</b>	Spain	<b>LS</b>	Lesotho	<b>SI</b>	Slovenia
<b>AM</b>	Armenia	<b>FI</b>	Finland	<b>LT</b>	Lithuania	<b>SK</b>	Slovakia
<b>AT</b>	Austria	<b>FR</b>	France	<b>LU</b>	Luxembourg	<b>SN</b>	Senegal
<b>AU</b>	Australia	<b>GA</b>	Gabon	<b>LV</b>	Latvia	<b>SZ</b>	Swaziland
<b>AZ</b>	Azerbaijan	<b>GB</b>	United Kingdom	<b>MC</b>	Monaco	<b>TD</b>	Chad
<b>BA</b>	Bosnia and Herzegovina	<b>GE</b>	Georgia	<b>MD</b>	Republic of Moldova	<b>TG</b>	Togo
<b>BB</b>	Barbados	<b>GH</b>	Ghana	<b>MG</b>	Madagascar	<b>TJ</b>	Tajikistan
<b>BE</b>	Belgium	<b>GN</b>	Guinea	<b>MK</b>	The former Yugoslav Republic of Macedonia	<b>TM</b>	Turkmenistan
<b>BF</b>	Burkina Faso	<b>GR</b>	Greece	<b>ML</b>	Mali	<b>TR</b>	Turkey
<b>BG</b>	Bulgaria	<b>HU</b>	Hungary	<b>MN</b>	Mongolia	<b>TT</b>	Trinidad and Tobago
<b>BJ</b>	Benin	<b>IE</b>	Ireland	<b>MR</b>	Mauritania	<b>UA</b>	Ukraine
<b>BR</b>	Brazil	<b>IL</b>	Israel	<b>MW</b>	Malawi	<b>UG</b>	Uganda
<b>BY</b>	Belarus	<b>IS</b>	Iceland	<b>MX</b>	Mexico	<b>US</b>	United States of America
<b>CA</b>	Canada	<b>IT</b>	Italy	<b>NE</b>	Niger	<b>UZ</b>	Uzbekistan
<b>CF</b>	Central African Republic	<b>JP</b>	Japan	<b>NL</b>	Netherlands	<b>VN</b>	Viet Nam
<b>CG</b>	Congo	<b>KE</b>	Kenya	<b>NO</b>	Norway	<b>YU</b>	Yugoslavia
<b>CH</b>	Switzerland	<b>KG</b>	Kyrgyzstan	<b>NZ</b>	New Zealand	<b>ZW</b>	Zimbabwe
<b>CI</b>	Côte d'Ivoire	<b>KP</b>	Democratic People's Republic of Korea	<b>PL</b>	Poland		
<b>CM</b>	Cameroon	<b>KR</b>	Republic of Korea	<b>PT</b>	Portugal		
<b>CN</b>	China	<b>KZ</b>	Kazakstan	<b>RO</b>	Romania		
<b>CU</b>	Cuba	<b>LC</b>	Saint Lucia	<b>RU</b>	Russian Federation		
<b>CZ</b>	Czech Republic	<b>LI</b>	Liechtenstein	<b>SD</b>	Sudan		
<b>DE</b>	Germany	<b>LK</b>	Sri Lanka	<b>SE</b>	Sweden		
<b>DK</b>	Denmark	<b>LR</b>	Liberia	<b>SG</b>	Singapore		
<b>EE</b>	Estonia						

**WIRELESS COMMUNICATION NETWORK USING TIME-VARYING  
VECTOR CHANNEL EQUALIZATION FOR ADAPTIVE SPATIAL  
EQUALIZATION**

**RELATED APPLICATIONS**

5           This application claims priority to the following applications and incorporates these applications by reference:

U.S. Ser. No. 08/394,652 filed on February 22, 1995;

U.S. Ser. No. 08/491,044, filed on June 16, 1995; and

U.S. Prov. App. No. 60/005,647 filed on October 19, 1995.

10

**FIELD**

The present invention relates to a wireless communication network that uses time-varying vector channel equalization for adaptive spatial equalization. In particular, the invention is used in a wireless communication network to improve the quality of communication.

15

**BACKGROUND**

Within wireless mobile communication systems, procedures for compensating for multipath effects are desirable. Unlike "line-of-sight" radio links, a number of signal transmission paths typically comprise each wireless communication channel, hence the term "multipath." An increase in primary path communication energy is desired with an attendant reduction in the interference energy radiated to mobile users over other non-primary paths. Often this increase in primary path

20

communication energy is achieved through generation of spatially selective, directive transmission beam patterns.

5 Some systems employ directive antennas at base station sites to increase the signal level received from and transmitted to each mobile user relative. Other systems use an antenna array that is used to form beams to increase the signal level received from and transmitted to each mobile user. In the systems with an antenna array, often called a phased array, weights are used to account for various angles that the beam will provide. Problems occur when severe multipath signals are created by a plurality of obstructions such as buildings and mountains. When severe  
10 multipath occurs, many systems suffer severe quality degradation. Known systems cannot sufficiently account for severe multipath and the result is reduced quality communication.

Figure 1 shows an illustrative representation of a wireless "multipath" communication channel between a base station 2 and a remote mobile user 4. The various signal transmission paths within each such multipath communication channel arise from reflection of the transmitted signal by dominant reflection surfaces 6, and by minor reflection surfaces 12, between the base station 2 and remote mobile user 4. Accordingly, techniques for improving signal reception in line-of-sight radio systems are often not directly applicable to multipath signal environments. For  
20 example, in line-of-sight system the "gain" of an antenna typically varies inversely to antenna beam width. However, if a given antenna beam width is made less than the angular region encompassing the various signal paths comprising a multipath communication channel, further reduction in the beam width may reduce the energy radiated along some of the angular paths. In turn, this may actually decrease the  
25 effective time average gain of the antenna.

These systems that perform blind transmission fail to employ a sufficient method for determining the received angle of the mobile station signal. As a result, known transmission beamforming techniques often use a trial and error approach that works barely satisfactorily, and does not always provide high quality  
30 communication.

## RELATED ART

Within wireless mobile communication systems, three techniques have been developed for improving communication link performance using directive transmit antennas: (i) selection of a particular fixed beam from an available set of fixed  
5 beams, (ii) adaptive beam forming based on receive signal angle estimates, (iii) adaptive transmission based on feedback provided by the remote mobile user, and (iv) adaptive transmit beam forming based upon the instantaneous receive beam pattern. Each of these techniques is described briefly below.

In the first technique, one of several fixed base station antenna beam patterns  
10 is selected to provide a fixed beam steered in a particular direction. The fixed antenna beams are often of equal beam width, and are often uniformly offset in boresight angle so as to encompass all desired transmission angles. The antenna beam selected for transmission typically corresponds to the beam pattern through which the largest signal is received. The fixed beam approach offers the advantage  
15 of simple implementation, but provides no mechanism for reducing the signal interference power radiated to remote mobile users within the transmission beam of the base station. This arises because of the inability of the traditional fixed beam approach to sense the interference power delivered to undesired users.

The second approach involves "adapting" the beam pattern produced by a  
20 base station phase array in response to changing multipath conditions. In such beamforming antenna arrays, or "beamformers", the antenna beam pattern is generated so as to maximize signal energy transmitted to ("transmit beamforming"), and received from ("receive beamforming"), an intended recipient mobile user.

While the process of transmit beamforming to a fixed location over a  
25 line-of-sight radio channel may be performed with relative ease, the task of transmitting to a mobile user over a time-varying multipath communication channel is typically considerably more difficult. One adaptive transmit beamforming approach contemplates determining each angle of departure (AOD) at which energy is to be transmitted from the base station antenna array to a given remote mobile  
30 user. Each AOD corresponds to one of the signal paths of the multipath channel, and is determined by estimating each angle of arrival (AOA) at the base station of signal energy from the given user. A transmit beam pattern is then adaptively

formed so as to maximize the radiation projected along each desired AOD (i.e., the AOD spectrum), while minimizing the radiation projected at all other angles. Several well known algorithms (e.g., MUSIC, ESPRIT, and WSF) may be used to estimate an AOA spectrum corresponding to a desired AOD spectrum.

5           Unfortunately, obtaining accurate estimates of the AOA spectrum for communications channels comprised of numerous multipath constituents has proven problematic. Resolving the AOA spectrum for multiple co-channel mobile units is further complicated if the average signal energy received at the base station from any of the mobile units is significantly less than the energy received from other mobile  
10           units. This is due to the fact that the components of the base station array response vector contributed by the lower-energy incident signals are comparatively small, thus making it difficult to ascertain the AOA spectrum corresponding to those mobile units. Moreover, near field obstructions proximate base station antenna arrays tend to corrupt the array calibration process, thereby decreasing the accuracy of the  
15           estimated AOA spectrum.

          In the third technique mentioned above, feedback information is received at the base station from both the desired mobile user, and from mobile users to which it is desired to minimize transmission power. This feedback permits the base station to "learn" the "optimum" transmit beam pattern, i.e., the beam pattern which  
20           maximizes transmission to the desired mobile user and minimizes transmission to all other users. One disadvantage of the feedback approach is that the mobile radio needs to be significantly more complex than would otherwise be required. Moreover, the information carrying capacity of each radio channel is reduced as a consequence of the bandwidth allocated for transmission of antenna training signals and mobile user feedback information. The resultant capacity reduction may be  
25           significant when the remote mobile users move at a high average velocity, as is the case in most cellular telephone systems.

          The fourth conventional technique for improving communication link performance involves use of an optimum receive beam pattern as the preferred  
30           transmission beam pattern. After calibrating for differences between the antenna array and electronics used in the transmitter and receiver, it is assumed that the instantaneous estimate of the nature of the receive channel is equivalent to that of the



transmit channel. Unfortunately, multipath propagation and other transient channel phenomenon can substantially eliminate any significant equivalence between frequency-duplexed transmit and receive channels, or between time-division duplexed transmit and receive channels separated by a significant time interval. As  
5 a consequence, communication link performance fails to be improved.

#### SUMMARY

The present invention relates to a wireless communication network that uses time-varying vector channel equalization for adaptive spatial equalization. In particular, the invention is used in a wireless communication network to improve the  
10 quality of communication.

Accordingly, it is an object of the invention to provide an adaptive receive and transmit beamforming technique that improves communication quality by utilizing the received signal energy from remote users.

It is another object of the invention to provide an adaptive receive and  
15 transmit beamforming technique which accounts for the presence of multipath fading inherent in the communication channel.

It is yet another object of the invention that the beamforming technique be independent of antenna array geometry, array calibration, or of explicit feedback control signals from remote users.

It is another object of the invention to provide adaptive receive and transmit  
20 beam forming that improves signal quality received by a desired user and while simultaneously reducing interference energy received by other undesired users so as to, within a cellular communication network, improve communication traffic capacity, and/or to increase base station coverage area, and/or to improve call  
25 quality.

An adaptive reception and transmission technique according to one embodiment of the invention offers the advantages of adaptive reception transmission using feedback without the associated mobile radio complexity increase and information capacity penalty. The technique has been developed to exploit  
30 structured variation which occurs in the multipath fading present in the wireless antenna array channel. Thus, multipath propagation effects are explicitly accounted

for in the problem approach. The technique is blind in that the antenna beam is formed in the absence of explicit knowledge of the array geometry, and without the necessity of array calibration or mobile feedback. The basic approach is to estimate the optimum receive and transmit antenna beam pattern based on certain statistical properties of the received antenna array signals. The optimum receive and transmit beam pattern is found by solving an optimization equation. The adaptive transceiver system is suitable for use in conjunction with either a diplexed transmit/receive antenna array, or with separate transmit and receive arrays.

Advantages of the invention include reduced interference and improved communication quality.

#### BRIEF DESCRIPTION OF THE FIGURES

Additional advantages of the invention will become apparent upon reading the following detailed description and upon reference to the drawings, in which:

Figure 1 is an illustrative representation of a multipath propagation channel between a base station and a remote user station;

Figure 2A is a block diagram of the physical implementation of a beamforming network configured to perform adaptive beam forming in accordance with the present invention;

Figure 2B is a block diagram of the physical implementation of a beamforming network in which a diplexor is employed to allow the antenna array to be used for both transmit and receive operation;

Figure 3 is a functional block diagrammatic representation of a beamforming network of the present invention;

Figure 4 is a graph depicting estimated signal SINR versus adaptation time for signal 1;

Figure 5 is a graph depicting estimated signal SINR versus adaptation time for signal 2;

Figure 6 is a graph depicting estimated signal SINR versus adaptation time for signal 3; and

Figure 7 is a graph showing theoretical performance bounds for variable  $\lambda$ .

## DETAILED DESCRIPTION

The present invention relates to a wireless communication network that uses time-varying vector channel equalization for adaptive spatial equalization. In particular, the invention is used in a wireless communication network to improve the quality of communication.

The exemplary embodiments are described herein with reference to specific configurations and protocols. Those skilled in the art will appreciate that various changes and modifications can be made to the exemplary embodiments while remaining within the scope of the present invention.

The problem we consider is blind adaptive spatial equalization with a multiple antenna base station array for the purpose of increasing reverse link spectral efficiency (Erlangs/Hz/base station) or range by canceling interference and enhancing the desired signal over noise. In blind equalization, the equalizer weight vector adaptation relies on the structure of the transmitted signal rather than a known training signal. While these techniques may be applied at the portable unit, this present embodiments focus on spatial equalization at the base station.

The communication channel formed between a portable wireless user and a wireless base station varies with time. When the portable moves with high velocity, the time variation in the channel can become severe. Over the past decade, a large body of work has been devoted to blind spatial equalization in time invariant channels. However, less work has been reported for large Doppler-spread conditions. For certain communication signals, including narrow-band FM, the known existing equalizer algorithms fail to converge in rapidly fading environments. This occurs because the channel changes significantly over the time interval required to determine the next equalizer weight vector update.

In most conventional adaptive algorithms, the signal quality criteria is minimum mean squared error (MMSE). We will show that this criteria may not be the best choice in rapidly fading channels. We will also show that the signal to interference plus noise ratio (SINR) criteria can be more robust in rapidly fading channels. With this information and motivation, an algorithm is developed which adaptively optimizes an interesting variation of the conventional SINR criteria.

The exemplary equalizer decomposes the received vector signal into a desired signal subspace and an interference plus noise subspace. In order to accurately estimate these two subspaces, we exploit the inherent time correlation structure that exists in the fading channel to obtain instantaneous blind estimates of the desired channel. Supplement 1 is provided for additional information and includes additional background and introduction material.

#### I. Overview of Beamforming Network

Turning now to Figure 2A, a block diagram is shown of the physical organization of a beamforming network 50 configured to perform adaptive beam forming in accordance with the present invention. In an exemplary embodiment the beamforming network 50 is disposed within a base station of a cellular communications network, in which is included a transceiver comprised of a radio frequency (RF) transmitter 52 and an RF receiver 54.

In the embodiment of Figure 2A, a base station antenna array 56 serves to produce independent transmit and receive antenna beams for facilitating communication with one or more mobile units (not shown). The term "receive channel vector" is employed to indicate that each antenna element within the base station antenna array 56 will form a propagation channel to a given remote user. The composite array channel may be represented as a vector having elements corresponding to each individual antenna channel. As is described herein, statistical characterization of the receive channel vector provides information which may be used by the base station to determine an "optimal" transmit beam pattern, i.e., a transmit beam pattern which maximizes the average signal-to-interference power delivered to a given mobile user. This obviates the need for the mobile unit to provide feedback information to the base station relating to propagation characteristics of the transmit channel. This in turn simplifies implementation of the mobile unit, and preserves channel resources for data transmission by eliminating the need for "mobile unit feedback" relating channel characteristics to the base station.

As is indicated by Figure 2A, a diplexer 58 can be employed to allow the antenna array 56 to be used for both transmit and receive operation by isolating the RF receiver 54 from the RF transmitter 52. A receive channel beamformer 60

cooperates with the RF receiver 54 to adaptively optimize the receive antenna beam in order to improve received signal quality. Similarly, a transmit channel beamformer 64 cooperates with the RF transmitter 52 to adapt the transmit antenna beam to optimize some characteristic of transmission quality. In an exemplary  
5 embodiment the transmit channel beamformer 64 and receive channel beamformer 60 are each implemented as a special purpose digital signal processor (DSP).

In another embodiment of the invention, distinct antenna arrays are used for signal reception and transmission as illustrated in Figure 2B. In the embodiment of Figure 2B, a diplexer is not required since a dedicated receive antenna array (not  
10 shown) is connected to the RF receiver 54, and a dedicated transmit antenna array (not shown) is connected to the RF transmitter 52. The receive and transmit antenna arrays are designed to provide identical radiation characteristics when operated at the receive and transmit frequencies, respectively. Accordingly, in many instances the physical geometries of the transmit and receive antenna arrays are simply physically  
15 scaled to account for the fractional difference in the receive and transmit RF wavelengths. The embodiment of Figure 2B substantially eliminates the potential introduction of error arising from use of a single antenna array and diplexer.

Turning now to Figure 3, a functional block diagrammatic representation is provided of a beamforming network of the present invention. In Figure 3, solid  
20 lines are used to represent functional elements and dashed lines are employed to identify the physical components of Figure 2. The RF receiver 54 is functionally comprised of a low-noise amplifier (LNA) network 110, and a complex downconverter 112. The complex downconverter 112 is disposed to frequency downconvert the received RF signal energy after processing by the LNA network  
25 110. The downconverted signal energy is then digitally sampled and provided to a receive channel weighting module 116 of the receive channel beamformer 60. The weights applied by the receive channel beamformer 60 to each of the M downconverted antenna element outputs  $x_{R,m}(k)$ ,  $m = 1$  to M, of the complex frequency downconverter 112 are determined by a receiver weight vector adaptation  
30 module 118. In the exemplary embodiment the receiver weight vector adaptation module 118 determines a receive channel weight vector,  $w_R$ , which maximizes the

signal quality received over the desired inbound frequency channel. The weight vector calculation is performed according to that described in Supplement 1.

In the embodiment of Figure 3, a vector channel covariance estimator 140 within the transmit beamformer 64 operates to produce a statistical characterization of a receive channel vector using: (i) the outputs  $x_{R,m}(k)$ ,  $m = 1$  to  $M$ , of the complex frequency downconverter 112, and (ii) an estimate of the desired signal  $\hat{S}_r(k)$  generated in the receive channel beamformer 60. For present purposes the receive channel vector may be viewed as being representative of the multipath communications channel from a mobile user (not shown in Figure 3) to the antenna array 56. In an exemplary embodiment the statistical characterization carried out within the covariance estimator 140 yields an estimated receive channel covariance matrix used during the transmit beamforming process. Throughout the following description, scalar quantities are represented using lower case characters of standard type, vector quantities are represented using lower case characters of bold type, and matrix quantities are represented using upper case characters of bold type.

Within the transmit channel beamformer 64, an optimal transmit beam pattern weight vector is generated by a transmit channel weight vector adaptation module 150 based on the results of the statistical characterization of the receive channel vector. This weight vector,  $w_T(t)$ , optimizes a particular aspect (e.g., average desired signal to undesired interference ratio) of the signal energy within the transmission range of the base station array 56. In the exemplary embodiment, the optimal transmit beam pattern weight vector is generated using the estimated desired receive channel covariance matrix,  $\hat{\mathbf{R}}_d(k)$ , and undesired interference covariance matrix,  $\hat{\mathbf{R}}_i(k)$ , both of which are compiled within the covariance estimator 140.

As is indicated by Figure 3, the signal information ( $S_T$ ) to be transmitted to the desired mobile radio unit is used to modulate a digital baseband carrier within a modulator 154. The modulated signal is then applied to a transmit channel weighting module 158 disposed to weight, on the basis of the optimized transmit pattern weight vector, the input signals corresponding to each element of the antenna array 56. The weighted set of input signals produced by the weighting module 158 are then upconverted in frequency within a complex frequency upconverter 160 of the RF transmitter 52. The resultant frequency-upconverted

signals are then amplified by a bank of power amplifiers 164, and provided to the antenna array 56 for transmission via diplexer 58.

In the exemplary embodiment an improved estimate of the received signal is obtained through utilization of a demodulator 170 and remodulator 172. The received signal is demodulated within demodulator 170 in order to recover the essential characteristics of the modulating signal. In the case of an analog FM signal, this involves recovery of the FM waveform. In the case of a digitally modulated signal (BPSK, FSK, QPSK, etc.), the demodulator 170 forms hard decisions as to the value of each digital symbol. The demodulated signal is then processed based upon some predefined characteristic of the signal and modulation pattern. For example, a demodulated analog FM signal could be lowpass filtered based upon a known signal information bandwidth as a means of obtaining an improved post-demodulation signal estimate. In the case of digital modulation, error correction could be implemented in order to remove bit errors, thus improving estimated signal quality. In addition, training signals (i.e., pilot tones, SAT tones, etc.) may optionally be employed in lieu of, or in conjunction with, the aforementioned "blind" techniques.

Again referring to Figure 3, the processed demodulated signal is then used by demodulator 172 to remodulate an RF carrier, thereby producing an improved modulated signal estimate. The improved signal estimate is then used by the receiver weight vector adaptation block 118 and the covariance estimate 140. Other techniques, which do not rely upon such a demodulation/remodulation procedure, can be devised for obtaining a sufficiently accurate received signal estimate. Figure 3 simply illustrates a particular exemplary embodiment incorporating a demodulator and remodulator.

In the present embodiment, the demodulator 170 and remodulator 172 or the receive channel beamformer 60 are operative to produce a received signal estimate  $\hat{s}_r$ . The quantity  $\hat{S}_r$  is then employed by the covariance estimator 140 to estimate the covariance matrix of the receive channel. The receive channel beamformer 60 could of course be replaced by numerous alternative structures including, for example, multi-antenna sequence estimators, maximum likelihood receiver structures, multiple element decision feedback equalizers, or similar alternative described in Supplement

1. Any of these alternative structures could also be used to provide the quantity  $\hat{s}_r$  for use in estimating the received channel covariance statistics.

## II. Blind Beamforming Using Multipath Signals

As mentioned above, an initial step within the present invention involves  
5 characterizing a receive channel vector representative of the multipath  
communications channel from a mobile user to a base station antenna array 56. In  
one embodiment, this is accomplished as described in Supplement 1. This  
embodiment employs a five step approach:

- 1) estimate the present signal sequence by passing the equalizer output  
10 through a decision device;
- 2) estimate the present channel state with an optimal estimation filter;
- 3) estimate the received interference plus noise signal sequence and use this  
error signal to update the interference covariance estimate;
- 4) update the spatial equalizer weight vector given the estimated desired  
15 channel and interference covariance; and
- 5) repeat the process with new desired signal estimates.

## III. Alternate Embodiments

Although the embodiments of the invention presented herein have been  
described in terms of optimization from a base station perspective, the teachings of  
20 the invention are equally applicable to optimum formation of the mobile unit antenna  
pattern. That is, the mobile unit antenna pattern is formed such that a desired level  
of power is transmitted to the one or more base stations with which the mobile unit  
is in communication, and so that transmission power is minimized to the other base  
stations within the communication network. Again, an initial step in this antenna  
25 pattern optimization procedure involves statistically characterizing the mobile unit  
receive channel vector. The results of this statistical characterization are then used  
to determine the beam pattern weight vector which maximizes a predetermined  
quality parameter (e.g., signal to noise ratio) of the signal received by the intended  
base station(s), while minimizing signal transmission to other base stations. At the



mobile station, the transmit antenna beam pattern is then generated in accordance with the transmit beam pattern weight vector.

Accordingly, in the following claims the term "central communications station" is intended to refer to either the base station or mobile unit configured to generate an optimized antenna beam pattern in accordance with the invention. When a base station comprises the central communications station, the mobile unit(s) in communication therewith are referred to as "remote communications station(s)". Conversely, when a mobile unit comprises the central communications station, the receiving base station(s) are identified as remote communications station(s).

While the present invention has been described with reference to a few specific embodiments, the description is illustrative of the invention and is not to be construed as limiting the invention. Various modifications may occur to those skilled in the art while remaining within the true spirit and scope of the invention as defined by the appended claims.

#### SUPPLEMENT 1

New blind adaptive spatial equalization techniques are proposed for severe multipath fading with co-channel interference. In rapidly fading environments, equalizer performance suffers with existing algorithms because the desired and interference channels change significantly over the update time interval. It is shown that for fast fading channels, conventional squared error equalizer cost functions can yield poor results. A new algorithm is proposed based on a variation of the SINR cost function coupled with optimal time varying channel estimation to improve signal tracking. In simulations, the algorithm achieves theoretically optimum time varying equalizer performance in extreme interference channels with narrow band FM signals and high velocity portables. These results are contrary to the widespread belief that high performance blind adaptive array processing is not possible for AMPS with severe combinations of Doppler spread, angle spread, and interference power.

## 1. INTRODUCTION

The problem we consider is blind adaptive spatial equalization with a multiple antenna base station array for the purpose of increasing reverse link spectral efficiency (Erlangs/Hz/base station) by canceling interference and enhancing the  
5 desired signal over noise. In blind equalization, the equalizer weight vector adaptation relies on the structure of the transmitted signal rather than a known training signal. While these techniques may be applied at the portable unit, this paper focuses on spatial equalization at the base station receiver.

The communication channel formed between a portable wireless user and a  
10 base station varies with time. When the portable moves with high velocity, the time variation in the channel can become severe. Over the past decade, a large body of work has been devoted to blind spatial equalization in time invariant channels. However, less work has been reported for large Doppler-spread conditions. For certain communication signals, including narrow-band FM, the known existing  
15 equalizer algorithms fail to converge in rapidly fading environments. This occurs because the channel changes significantly over the time interval required to determine the next equalizer weight vector update.

In most conventional adaptive algorithms, the signal quality criteria is minimum mean squared error (MMSE). We will show that this criteria may not be  
20 the best choice in rapidly fading channels. We will also show that the signal to interference plus noise ratio (SINR) criteria can be more robust in rapidly fading channels. With this motivation, an algorithm is developed which adaptively optimizes an interesting variation of the conventional SINR criteria. The proposed equalizer decomposes the received vector signal into a desired signal subspace and  
25 an interference plus noise subspace. In order to accurately estimate these two subspaces, we exploit the inherent time correlation structure that exists in the fading channel to obtain instantaneous blind estimates of the desired channel.

The multiple antenna wireless channel model is briefly reviewed in Section 2. The spatial equalization problem is developed and a solution is proposed in Section  
30 3. Simulation results demonstrating the performance of the adaptive spatial equalizer with multiple co-channel narrow-band analog FM signals in a high

Doppler spread, high angle spread fading environment are presented in Section 4. Conclusions are offered in Section 5.

## 2. CHANNEL MODELS

The wireless communication channel is characterized by scattering and reflecting bodies which cause severe multipath. This is illustrated in Figure 1. The channel is also time-varying when the receiver is in motion. The time-variation is characterized by rapid amplitude fluctuations and therefore is called a fading channel. These short-term complex amplitude variations are often well modeled by a multiplicative Gaussian random process. The channel also exhibits long-term variations which are due to shadowing by large physical features. This variation is much less structured and is sometimes well modeled as a log-normal multiplicative random variable.

Let  $s_0(t)$  be the complex analytic baseband representation of the transmitted signal. If the remote transmitter has a single antenna and the wireless base station receiver has multiple antennas, then the direction of arrival of the 1<sup>th</sup> path from the receiver (given by  $\theta_{0,1}$ ) is of importance. The baseband vector output of the base station receiver due to the 1<sup>th</sup> propagation path is

$$x_1(t) = a(\theta_{0,1}) \beta_{0,1}(t) s_0(t) \quad (1)$$

where  $a(\theta_{0,1})$  denotes the base station array response to the path arriving at the angle  $\theta_{0,1}$ . The composite complex-valued propagation path strength  $\beta_{0,1}(t)$  is given by

$$\beta_{0,1}(t) = \frac{1}{d_0^{\frac{\eta}{2}}} \alpha_{0,1}(t) \sqrt{\Gamma_{0,1}} \quad (2)$$

where  $\alpha_{0,1}(t)$  is the complex fast fading parameter,  $\Gamma_{0,1}$  is the shadow fading loss factor,  $d_0$  is the distance from the mobile to the base station and  $\eta$  is the path power-loss exponent. In Equation (1) an inherent assumption is that each propagation path amplitude is frequency invariant over the bandwidth of the signal and that the relative time delay between different arriving paths is small compared to the inverse signal bandwidth. Below, it is further assumed that the array response  $a(\theta_{0,1})$  is

invariant over the signal bandwidth. This set of conditions is commonly referred to as the narrow band assumption.

The received time-domain signal vector is the sum of all dominant reflector paths and the additive receiver noise  $n(t)$

$$x(t) = \sum_{l=1}^L x_l(t) + n(t) = \sum_{l=1}^L a(\theta_{0,l}) \beta_{0,l}(t) s_0(t) + n(t) \tag{3}$$

5 Clearly from the above model, the time-varying response of the continuous-time desired portable channel is

$$h_0(t) = \sum_{l=1}^L a(\theta_{0,l}) \beta_{0,l}(t) \tag{4}$$

The channel given in Equation (3) is sampled at a rate of  $T$  seconds. The output samples can be rewritten as,

$$x_k = h_{0,k} s_{0,k} + n_k \tag{5}$$

with the discrete time channel response given by

$$h_{0,k} = \sum_{l=1}^L a(\theta_{0,l}) \beta_{0,l,k}$$

10 In the presence of multiple user co-channel interference, we have the received signal vector

$$x_k = h_{0,k} s_{0,k} + \sum_{j=1}^P h_{j,k} s_{j,k} + n_k \tag{6}$$

15 When portables move at high velocities, giving rise to large Doppler frequency shifts, the channel vector complex M-space direction and magnitude become rapidly varying functions of time. The propagation environment determines the exact nature of the vector variation. The central path angle and relative spread in path angles (angle spread) for each channel determines the Eigenvectors and Eigenvalues of the time averaged vector subspace spanned by the channel. The Doppler spread determines the rate of time variation within the channel subspace.

### 3. SPATIAL CHANNEL EQUALIZATION

The techniques proposed in this paper do not consider conventional antenna concepts such as beam width, gain and side lobe rejection. Instead, the antenna array is viewed from a statistical signal processing perspective. Each antenna array output represents a phase and amplitude coherent sensor which contains a weighted sum of the desired signal, the undesired signals, and noise. By applying an appropriate complex weight to each sensor signal and then summing the outputs, it is possible to cancel undesired interference and enhance the desired signal above the noise. The sensor weights are described by an equalizer weight vector  $w$ . If the weight vector is adapted in real time in an optimal manner, it is possible to achieve performance that is far superior to fixed beam systems. To implement a fully adaptive array, a bank of phase and amplitude coherent digital RF receivers is required. Recent technology advances in wide band digital RF converter technology make such systems not only feasible, but also economical. An Adaptive spatial equalizer conceptual diagram is illustrated in Figure 3.

#### 3.1. Algorithm Cost Function

In order to adapt the spatial equalizer weight vector, it is necessary to define an equalizer signal quality optimization function. Here, we consider two possible cost functions, MMSE and maximum SINR. We will show that for slowly varying channels, these cost functions are equivalent to within a scalar constant. We will also show that for rapidly varying channels, with a fixed equalizer weight applied to a finite block of received data, the two cost functions result in very different solutions and the maximum SINR criteria is often a more sensible choice. First, the slowly varying channel case is considered. Then the case where the channels fade rapidly with respect to the equalizer adaption rate is discussed.

Under the slowly varying channel condition, if perfect knowledge were available for the instantaneous desired channel, the instantaneous co-channel interference channels, the desired signal variance, the interference signal variances, and the noise variance, the well known "instantaneous" MMSE spatial equalizer solution is

$$w_{MSE,k} = \arg \min_w E \left\{ |w^* x_k - s_{0,k}|^2 \right\} = \sigma_{s_0}^2 R_{xx}^{-1} h_{0,k} \quad (7)$$

where  $R_{x,k}$  is the "instantaneous covariance" matrix for the received signal vector defined by

$$R_{x,k} \triangleq E \{x_k x_k^*\} = \sigma_{so}^2 h_{0,k} h_{0,k}^* + R_{u,k} \tag{8}$$

and  $R_{u,k}$  is the instantaneous interference plus noise covariance matrix defined by

$$R_{u,k} \triangleq \sum_{j=1}^P \sigma_{2j}^2 h_{j,k} h_{j,k}^* + \sigma_n^2 I \tag{9}$$

The above expressions are derived under the assumption that the desired signal, all interfering signals, and the noise are uncorrelated.

Given the same apriori knowledge, the maximum SINR problem is

$$w_{SNR,k} \triangleq \arg \max_w \frac{E\{|w^* h_{0,k} s_{0,k}|^2\}}{E\{|w^* [\sum_{j=1}^P h_{j,k} s_{j,k} + n_k]|^2\}} \tag{10}$$

The solution for  $w_{SNR,k}$  is easily derived as the generalized eigenvector associated with the maximum generalized eigenvalue of the matrix pencil

$$[h_{0,k} h_{0,k}^*, R_{u,k}]$$

which is equivalent to the solution

$$w_{SNR,k} = R_{u,k}^{-1} h_{0,k} \tag{11}$$

since

$$h_{0,k} h_{0,k}^*$$

is obviously rank 1. Using the matrix inversion lemma, we can prove that the MMSE solution to Equation (7) is equivalent to the maximum SINR solution to Equation (11) to within a scalar constant given by

$$w_{MSE,k} = \left( \frac{1}{h_{0,k}^* R_{u,k}^{-1} h_{0,k} + \frac{1}{\sigma_{so}^2}} \right) w_{SNR,k} \tag{12}$$

So, we conclude that with perfect instantaneous desired and undesired channel knowledge the MMSE and SINR cost functions lead to nearly identical solutions.

In rapidly time varying channel setting, perfect instantaneous knowledge of the channels is not available. The channels often change appreciably over the adaptation interval of the equalizer algorithm. In such cases, there can be a substantial difference between the MMSE and SINR adaption criteria. Consider an adaptive spatial equalization algorithm based on an optimal MMSE solution similar to Equation (7), but the algorithm employs a sliding window of length N samples for each weight vector. Numerous proposed schemes apply a sliding window. The sliding window MMSE problem statement may be written as

$$w_{MSE,k}^{(N)} = \arg \min_w E \left\{ \| w^* X_k - s_{0,k} \|^2 \right\} \quad (13)$$

where the received signal vector sequence

$$X_k = [x_k \dots x_{k-N+1}]$$

and the transmitted desired signal sequence

$$s_{0,k} = [s_{0,k} \dots s_{0,k-N+1}]$$

Again assuming perfect knowledge of the channels, we can show that the solution is

$$w_{MSE,k}^{(N)} = \sigma_{sq}^{-2} \left[ \sum_{j=0}^P \sigma_{sj}^2 \langle h_{j,k} h_{j,k}^* \rangle_N + \sigma_n^2 I \right]^{-1} \langle h_{0,k} \rangle_N \quad (14)$$

where

$$\langle (\cdot) \rangle_N = \frac{1}{N} \sum_{n=k-N+1}^k (\cdot)_n$$

is the N-sample averaging operator. We can compare this finite block length solution to the ideal instantaneous solution to Equation (7) by re-writing Equation (14) as

$$w_{MSE,k}^{(N)} = \sigma_{sq}^{-2} [R_{s,k} + \Delta R_k]^{-1} [h_{0,k} + \Delta h_k] \quad (15)$$

where the covariance error term is

$$\Delta R_k = \frac{1}{N} \sum_{n=k-N+1}^{k-1} \sum_{j=0}^P \sigma_{sj}^2 h_{j,n} h_{j,n}^* - \frac{N-1}{N} \sum_{j=0}^P \sigma_{sj}^2 h_{j,k} h_{j,k}^* \quad (16)$$

and the channel error term is

$$\Delta h_k = \frac{1}{N} \sum_{n=k-N+1}^{k-1} h_{0,n} - \frac{N-1}{N} h_{0,k} \tag{17}$$

For a time varying channel, as N increases, the error terms in the finite block length solution increase. The effect of the covariance error  $\Delta R_k$  is to add false components to the interference subspace in the equalizer solution. The effect of the channel error  $\Delta h_k$  is additive. The combination of these effects is highly non-linear. Thus, it is not clear that applying the MMSE criteria to finite length time blocks with rapidly fading channels will result in desirable performance. As a simple example, given the zero mean channel model from the previous section, it can be shown that

$$\lim_{N \rightarrow \infty} w_{MSE,k}^{(N)} = 0 \tag{18}$$

which is clearly a useless solution. This motivates a search for cost functions which are more robust in time varying channels.

In contrast to the above, applying the SINR criteria to a block of received data always results in a useful equalizer solution, even in the limit. Carrying through a similar development for the SINR equalizer, we have

$$w_{SNR,k}^{(N)} = \arg \max_w \frac{E \left\{ \left| w^* [h_{0,k} s_{0,k} \dots h_{0,k-N+1} s_{0,k-N+1}] \right|_2^2 \right\}}{E \left\{ \left| w^* \left( \sum_{j=1}^P [h_{j,k} s_{j,k} \dots h_{j,k-N+1} s_{j,k-N+1}] + [n_k \dots n_{k-N+1}] \right) \right|_2^2 \right\}} \tag{19}$$

The solution for

$$w_{SNR,k}^{(N)}$$

is the generalized eigenvector associated with the maximum generalized eigenvalue of the matrix pencil

$$\left( h_{0,k} h_{0,k}^* + \sum_{j=1}^P \sigma_{s_j}^2 (h_{j,k} h_{j,k}^* + \sigma_n^2 I) \right)$$

This solution has a precise meaning: "Given N received samples and one equalizer weight vector setting, maximize the ratio of the average received signal energy divided by the average noise plus interference energy." The theoretically achievable



SINR will decrease as N increases because the interference and desired signal covariance matrices will become more well conditioned thus reducing the maximum eigenvalue of the matrix pencil. However, this degradation is graceful and is easily

Equalizer Solution

5 (a)

$$[\sum_{j=1}^P \sigma_{s_j}^2 h_{j,k} h_{j,k}^* + \sigma_n^2 I]^{-1} h_{0,k}$$

(b)

$$[\sum_{j=1}^P \sigma_{s_j}^2 \langle h_{j,k} h_{j,k}^* \rangle_N + \sigma_n^2 I]^{-1} h_{0,k}$$

(c)

$$v_{\max} (\langle h_{0,k} h_{0,k}^* \rangle_N, [\sum_{j=1}^P \sigma_{s_j}^2 \langle h_{j,k} h_{j,k}^* \rangle_N + \sigma_n^2 I])$$

analyzed. This will be illustrated in Section 4.

10 It is also possible to use convenient combinations of instantaneous and average channel information to form variations on the SINR criteria. Three variations of the SINR equalizer are presented in Table 3.1. As we will see in the next section, it is also sometimes advantageous to replace the averaging operation

$$\langle (\cdot) k \rangle_N$$

with the exponentially weighted averaging operator given by

$$\langle (\cdot) k \rangle_\lambda \doteq \sum_{n=0}^k \lambda^{k-n} (\cdot)_n, \quad 0 < \lambda < 1 \tag{20}$$

3.2 Algorithm Description

15 The highest potential equalizer performance is obtained with the SINR cost function based on the instantaneous desired channel and the instantaneous undesired interference subspace. A second solution is possible which is based on a short term time average interference subspace description and the instantaneous desired channel. The performance for this equalizer is lower than the first since the  
 20 interference matrix includes subspace components from past interference channel states. The relative performance decrease is dependent on the angle of arrival spread

and the product of the time window length and the Doppler frequency. A third equalizer solution involves subspace averaging for both the desired and undesired channels with still lower performance.

From the above, it would seem obvious to choose the instantaneous criteria. However, in time varying interference dominated channels, blind equalization algorithms which rely on signal property restoral are subject to false signal tracking. False tracking occurs when the instantaneous desired channel is in a deep fade and the algorithm converges to a stronger interference signal. With a time average interference covariance solution, the algorithm becomes less susceptible to false tracking as the effective interference subspace averaging window is increased. Thus, a trade-off exists between achieving the optimum instantaneous SINR performance and robust signal tracking. This motivates us to choose an SINR equalizer solution which has the form

$$\hat{w}_k = \frac{[\langle \hat{R}_{u,k} \rangle_\lambda]^{-1} \hat{h}_k}{\hat{h}_k^* [\langle \hat{R}_{u,k} \rangle_\lambda]^{-1} \hat{h}_k} \quad (21)$$

where  $\langle \cdot \rangle$  implies an estimated value. We note that the trade-off between instantaneous SINR performance and tracking robustness can easily be adjusted by varying the forgetting factor  $\lambda$ . Increasing  $\lambda$  results in a decrease in the rate of false tracking occurrences, and a decrease in performance as compared to the ideal instantaneous solution. Several techniques are available to detect and recover from false tracking events, so signal quality is maintained as long as the occurrence rate is low. The proposed equalization strategy is divided into five steps which are

1. Estimate the present signal sequence by passing the equalizer output through a decision device. [Equations (22) and (23)].
2. Estimate the present channel state with an optimal estimation filter. [Equations (25) and (27)].
3. Estimate the received interference plus noise signal sequence. Use this error signal to update the interference covariance estimate. {Equations (30) and (31)}.
4. Update the spatial equalizer weight vector given the estimated desired channel and interference covariance. [Equation (21)].

5. Repeat the process with new desired signal estimates.

This adaptation procedure is represented by the block diagram shown in Figure 3. Each of the algorithm steps are described below.

Using the present equalizer setting, a short block of received data is equalized

$$\hat{s}_{0,k} = \hat{w}_k^* X_k = [\hat{s}_k \dots \hat{s}_{k-N+1}] \tag{22}$$

The equalizer output is then passed through a non-linear detection function  $d(\cdot)$  which restores some known property of the transmitted portable signal. In the case of an FM signal set, the nonlinear function can simply force the signal modulus to a constant value, or a more sophisticated combination modulus forcing and phase filtering function has been proposed. In the case of finite alphabet digital signals, the nonlinear function is a symbol waveform detector. The output of the detection function is the estimated signal sequence

$$\hat{s}_{0,k} = d(\hat{s}_{0,k}) \tag{23}$$

In order to accurately determine the interference subspace and the optimal weight vector, it is critical to have an accurate estimate of the desired channel. The channel exhibits highly structured time auto-correlation behavior for each antenna element. This structured variation should be exploited to improve our ability to identify and track the desired channel. The channel is estimated in two steps. First, a "measurement" of the reverse channel  $h_{0,k}$  is obtained by solving

$$\hat{h}_{0,k} = \arg \min_h \|h \hat{s}_{0,k} - X_k\|_F^2 \tag{24}$$

Here, the channel is assumed time invariant over the data block. The data block must be a very small fraction of the inverse Doppler frequency to maintain this assumption. Assuming the noise plus interference is Gaussian, the solution to Equation (24) is the deterministic maximum likelihood estimate

$$\hat{h}_{0,k} = X_k \hat{s}_{0,k}^H \tag{25}$$

The channel measurements defined by Equation (25), provide a true channel plus noise measurement model since

$$Xk\hat{S}_{0,k}^{-1} = h_{0,k} + Nk\hat{S}_{0,k}^{-1} = h_{0,k} + u_k \tag{26}$$

where  $N_k = [n_k \dots n_{k-N+1}]$  and  $u_k$  is the equivalent channel measurement noise term

$$Nk\hat{S}_{0,k}^{-1}$$

The final channel estimate is a weighted sum of the present and past channel measurements

$$\hat{h}_k = \sum_{n=0}^{N-1} f_n \hat{h}_{k-n} \tag{27}$$

with the FIR filter vector  $f$  given by

$$f = \underset{f}{\text{arg min}} E\{|\hat{h}_k - h_{0,k}|^2\} \tag{28}$$

5 The solution to Equation (28) is a Wiener filter given by

$$f = [E\{\beta_k \beta_k^* + E\{\mu_k \mu_k^*\}]^{-1} E\{\beta_k \beta_k^*\} \tag{29}$$

where

$$\beta_k = [\beta_k \dots \beta_{k-N_{h,2}+1}]^T$$

is a vector of scalar fading variables representing the time varying complex amplitude of one channel vector entry in  $h_k$  and  $\mu_k =$

$$[u_k \dots u_{k-N_{u,2}+1}]^T$$

is the corresponding time varying measurement noise vector for each entry in  $u_k$ .

10 The filter solution to Equation (29) can be based on ensemble average statistics or based on worst case sample path behavior. The ensemble average covariance function for  $\beta_k$  is:

$$\sigma_\beta^2 J_\omega(\omega, \tau)$$

The noise covariance is determined by the nature of the additive receiver noise and the short term cross-correlation and autocorrelation behavior of the interference  
15 signals.

The solution for the channel estimation filter is also dependent on two

$$SNR \left( \frac{\sigma_B^2}{\sigma_w^2} \right)$$

variables, the maximum Doppler shift and the channel measurement . In the interest of complexity reduction, the filter design can be based on the maximum expected Doppler shift and the minimum expected SNR. Performance is enhanced if the  
 5 Doppler and SNR are estimated and the filter coefficients are adapted either by resolving Equation (29) or by choosing the estimation filter from a fixed set of pre-computed possibilities.

To estimate the undesired interference subspace, the undesired signal sequence is estimated

$$\hat{X}_{u,k} = X_k - \hat{H}_k \hat{s}_{0,k} \tag{30}$$

10 The interference covariance estimate is then updated

$$\langle \hat{R}_{u,k} \rangle_\lambda = \lambda \hat{R}_{u,k-1} + \hat{X}_{u,k} \hat{X}_{u,k}^* \tag{31}$$

The weight vector is now given by Equation (21). The sample index  $\kappa$  is incremented by N and the next iteration is initiated.

It should be noted that many variations on this basic algorithm are possible. Several implementations involving sample by sample recursions have been  
 15 evaluation. The FIR channel estimation filter can be replaced by an observer based filter with various state-space model possibilities. The fundamental contributions are the blind SINR adaption criteria, the subspace decomposition and the use of correlated desired channel behavior to improve estimation accuracy for the desired channel and the interference subspace.

20 **4. SIMULATIONS**

Simulations have been conducted to test the spatial equalizer approach discussed in the previous section. The signals are narrow-band FM with the following parameters:

$$f_o = 1\text{GHz (RF center frequency)}$$

$$\begin{aligned}
 f_D &= \pm 103\text{Hz} \text{ (} v = 70\text{mph)} \\
 B_{\text{voice}} &= 4\text{KHz} \text{ (voice waveform bandwidth)} \\
 \Delta f_{\text{voice}} &= \pm 12\text{KHz} \text{ (peak voice FM excursion)} \\
 f_{\text{SAT}} &= 6\text{KHz} \text{ (SAT tone offset)} \\
 5 \quad \Delta f_{\text{SAT}} &= \pm 2\text{KHz} \text{ (peak SAT tone FM excursion)}
 \end{aligned}$$

Here, we present one example simulation scenario in which the base station antenna is a six element linear array with inter-element spacing of  $\lambda/2$ . There are three transmitted mobile signals, each with equal average strength. Each signal arrives from four different paths. Each of the four paths for each signal are spread over a  $30^\circ$  range. Each path for each signal has independent fading generated by 10 randomly located local scatterers. The central path angles of arrival for the three signals are  $40^\circ$ ,  $20^\circ$  and  $-70^\circ$ . Complex Gaussian band limited noise is added at the output of each antenna element. The ratio of the time averaged received signal power to average additive noise power is 20dB per element. As the instantaneous channel fades, the instantaneous signal to additive noise power at each element 15 varies above and below 20dB.

The blind spatial equalization algorithm described in the previous section was used to recover estimates for each of the three FM signals. The detection function  $d(\cdot)$  is the complex sign. The data block length  $NT$  is  $200\mu\text{S}$  with a corresponding adaptation rate of 5KHz. This is sufficient to support the assumption that the channel is constant over each block. The blind algorithm restarts when false signal tracking events are detected. False tracking detection can be implemented by several methods including monitoring SAT tone quality. 20

The instantaneous SINR for the recovered signal waveforms  $\tilde{s}_{0,k}$  at the output of the spatial equalizer for each of the three signal estimates is plotted (solid) along with the corresponding optimum theoretical instantaneous SINR performance (dash) in Figures 4 through 6. The instantaneous SINR for one omni-directional antenna element (dash-dot) is also plotted to provide a reference for SINR improvement. Optimum performance is determined by the maximum eigenvalue of the 30 instantaneous matrix pencil

$$[h_{0,k}, h_{0,k}^*, R_{u,k}]$$

All three simulation runs were performed on the same data set with the same initial weight vector setting. The only difference is the signal selected for tracking. Conventional CM algorithms were also applied to the simulated data set. None of the CM algorithms were found to converge to any of the three signals.

5           The one second time average estimated signal SINR for signals 1 through 3 is 18.8dB, 17.2dB and 15.7dB. The average estimated signal SINR loss with respect to the optimal instantaneous solution is 0.7dB, 1.9dB, and 3.8dB respectively. This is accounted for by the performance loss associated with the subspace forgetting factor  $\lambda$ . Figure 4 illustrates the theoretical limits for instantaneous SINR  
10 performance sacrifice for signal 3 due to increasing the interference subspace forgetting factor  $\lambda$ . In Figure 4, the optimal instantaneous SINR solution (solid) is plotted along with the maximum eigenvalue of the pencil

$$[h_{0,k} h_{0,k}^* (R_{u,k}) \lambda]$$

(dash) with  $\lambda = 0.9999$  which approaches infinite averaging. The theoretical performance penalty, averaged over one second, between the optimal instantaneous  
15 interference covariance solution and the infinite average interference covariance solution is 4.6dB for the signal 3 example. These simulation results suggest that the proposed algorithm achieves optimal theoretical performance when the theoretical penalty due to interference subspace averaging is taken into account.

## CONCLUSIONS

20           A new approach for blind adaptive spatial equalization in rapidly fading channels has been developed. The algorithm performs well in an extreme narrow band FM communication environment with high Doppler spread, high angle spread, and strong multiple co-channel interferers. We believe that these are the first reported results for a blind spatial equalizer which performs well on AMPS type  
25 signals in a high velocity portable multipath setting. The approach involves two fundamental results:

1. For certain communication signals in rapidly fading channel settings, a modified version of the SINR adaptive equalizer cost function is superior to conventional squared error cost functions.

2. Optimal estimation techniques can be applied to obtain accurate channel estimates in the presence of noise and interference. High quality channel estimates are crucial to obtaining an accurate estimate of the interference subspace used to determine the SINR equalizer solution.

5           Extensions of our approach have been developed for multiple antenna delay-spread digital FIR communication channels. These time varying space-time equalizer results will be reported in a future paper.

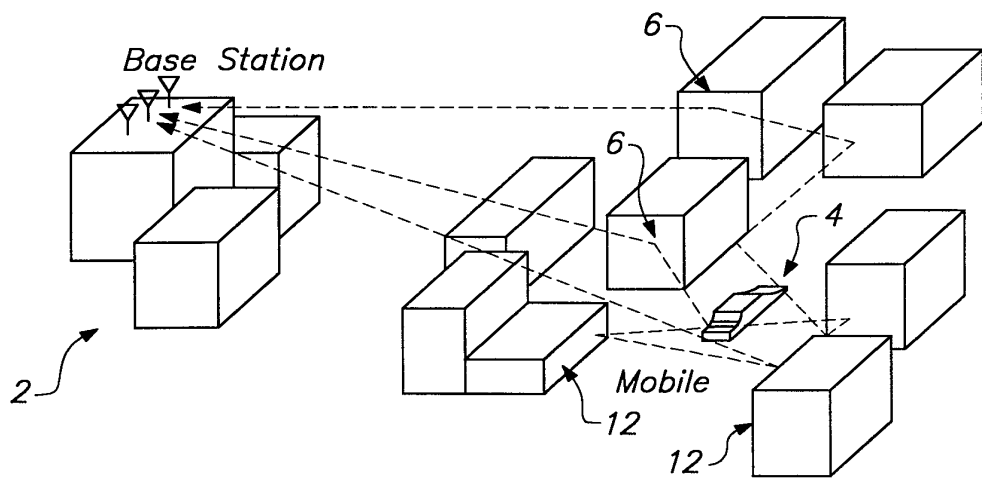


## WHAT IS CLAIMED IS:

1. A base station for communicating over a radio network with a remote station, comprising:
  - 5 a plurality of antennas and receivers to receive inbound information signals from the remote station;
  - a signal processor coupled to said receivers and configured to compute a plurality of weights for the purpose of weighting each of the receiver information signals and combining said weighted signals together in a manner that improves the signal quality at the output of said signal processor for both geographically  
10 stationary and rapidly moving remote stations.
  
2. The base station of claim 1, wherein said signal processor includes:
  - means for statistically characterizing a receive channel vector, said receive  
channel vector being representative of a receive communications channel over which  
signal energy is transmitted from said at least one remote communications station to  
15 said central communications station; and
  - means for generating said plurality of weights based on results of statistical  
characterization of said receive channel vector.
  
3. The base station of claim 2, wherein said signal processor includes:
  - 20 one or more time-varying channel estimation filters for estimating said receive channel vector.
  
4. The base station of claim 2, wherein said means for statistically  
characterizing further include means for compiling an estimated receive channel  
covariance matrix.
  
5. The base station of claim 4, wherein said means for generating said beam  
25 pattern weight vector includes means for averaging said estimated receive channel  
covariance matrix in order to form an estimated transmit channel covariance matrix.

6. The base station of claim 5, further including means for using said estimated transmit channel covariance matrix to form objective and constraint functions, said beam pattern weight vector being obtained by solving said objective and constraint functions.
- 5 7. A method of communicating over a radio network with a remote station using a base station having a plurality of antennas and receivers and a signal processor, said method comprising the steps of:
- receiving inbound information signals from the remote station via said plurality of antennas and receivers;
- 10 computing a plurality of weights in said signal processor for the purpose of weighting each of the receiver information signals and combining said weighted signals together in a manner that improves the signal quality at the output of said signal processor for both geographically stationary and rapidly moving remote stations.
- 15 8. The method of claim 7, wherein said computing step includes the steps of: statistically characterizing a receive channel vector, said receive channel vector being representative of a receive communications channel over which signal energy is transmitted from said at least one remote communications station to said central communications station; and
- 20 generating said plurality of weights based on results of statistical characterization of said receive channel vector.
9. The method of claim 8, wherein said method further includes the step of: estimating said receive channel vector.
- 25 10. The method of claim 8, wherein said statistically characterizing step includes the step of: compiling an estimated receive channel covariance matrix.

11. The method of claim 10, wherein said generating said beam pattern weight vector step includes the step of:
  - averaging said estimated receive channel covariance matrix in order to form an estimated transmit channel covariance matrix.
  
- 5 12. The method of claim 11, further comprising the step of:
  - using said estimated transmit channel covariance matrix to form objective and constraint functions, said beam pattern weight vector being obtained by solving said objective and constraint functions.



**FIG. 1**

**SUBSTITUTE SHEET (RULE 26)**

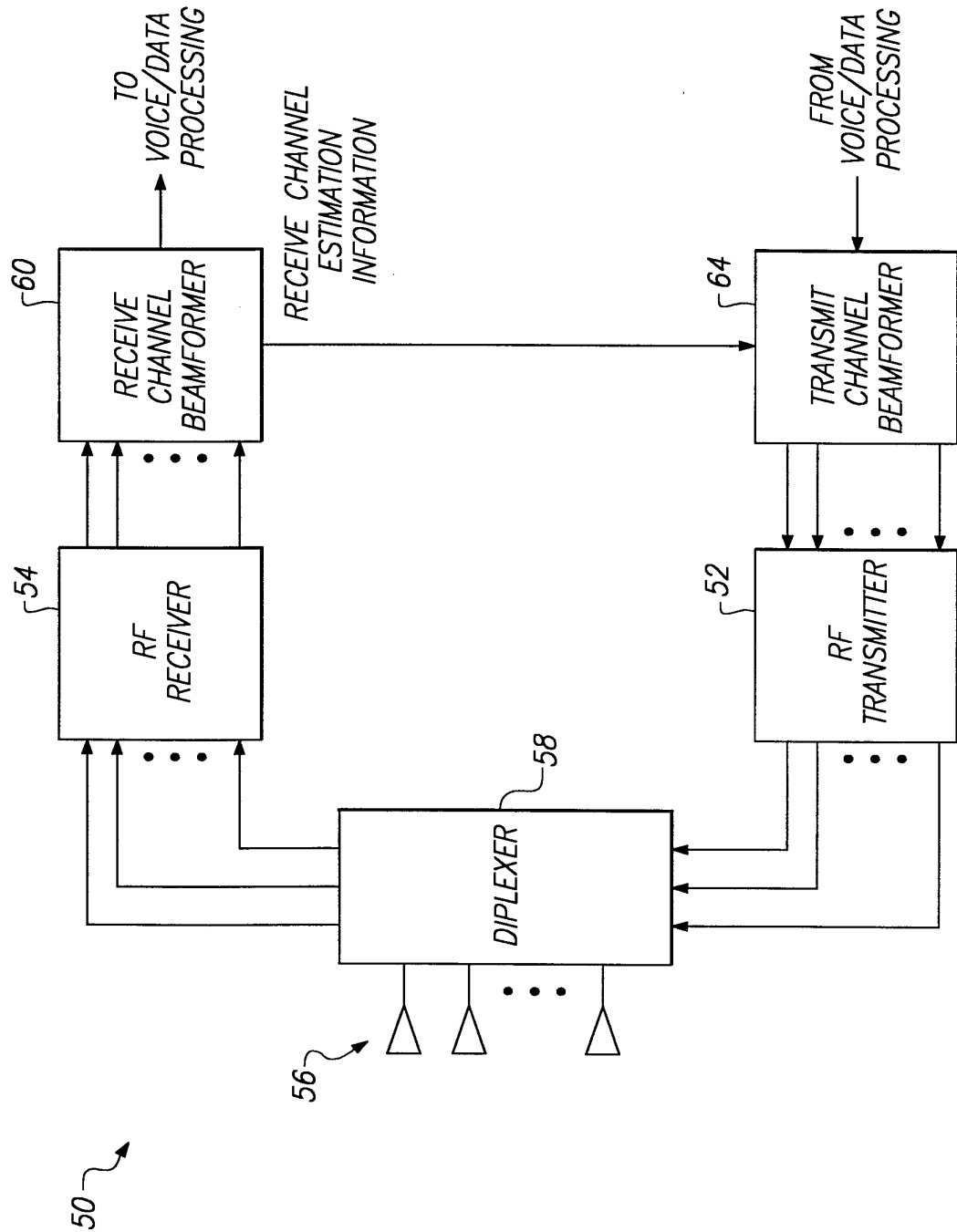


FIG. 2A

SUBSTITUTE SHEET (RULE 26)

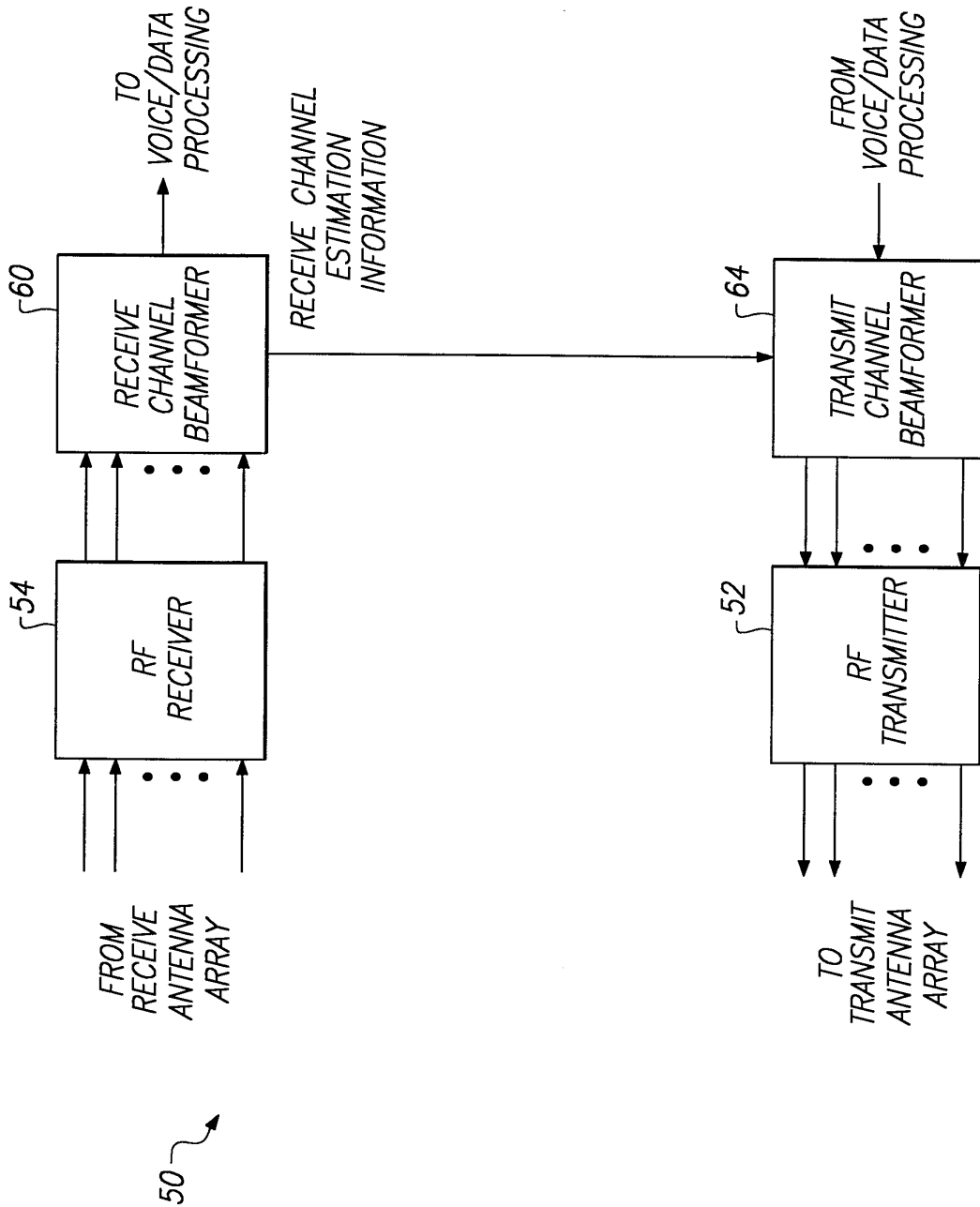


FIG. 2B

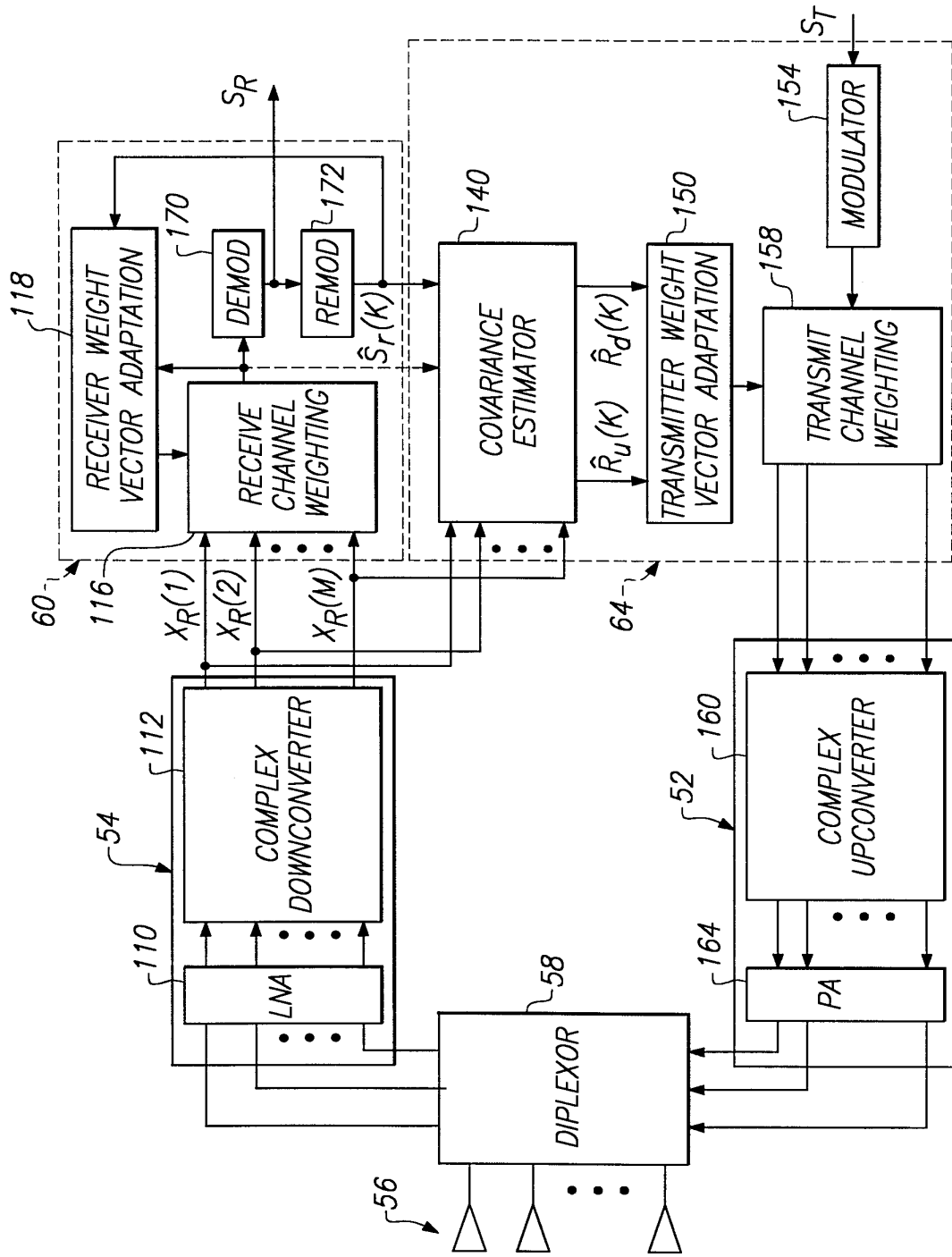
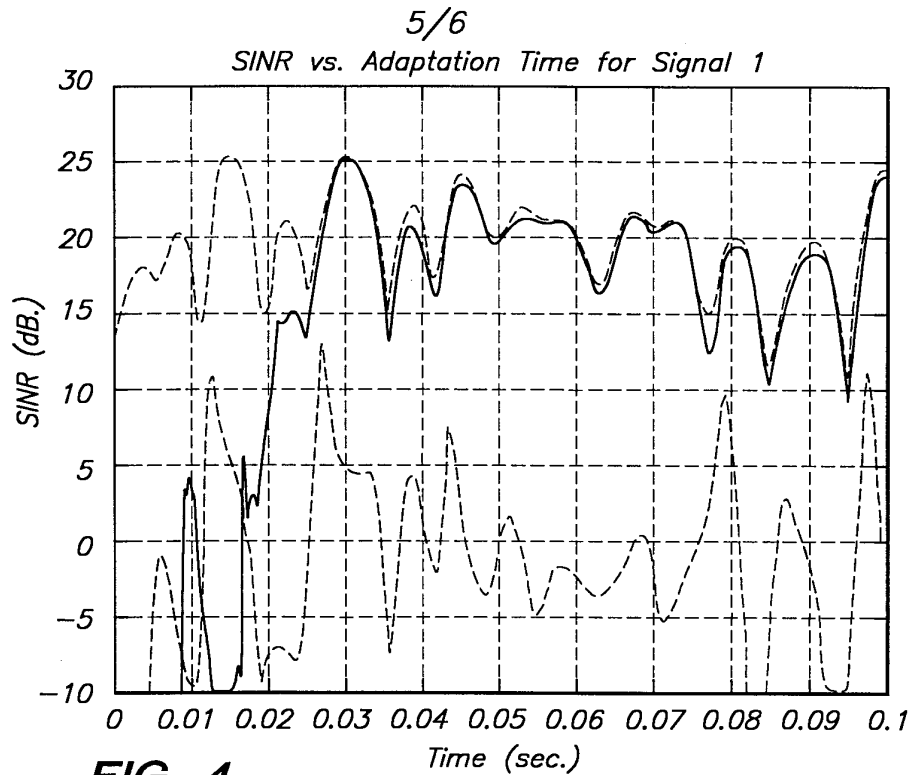
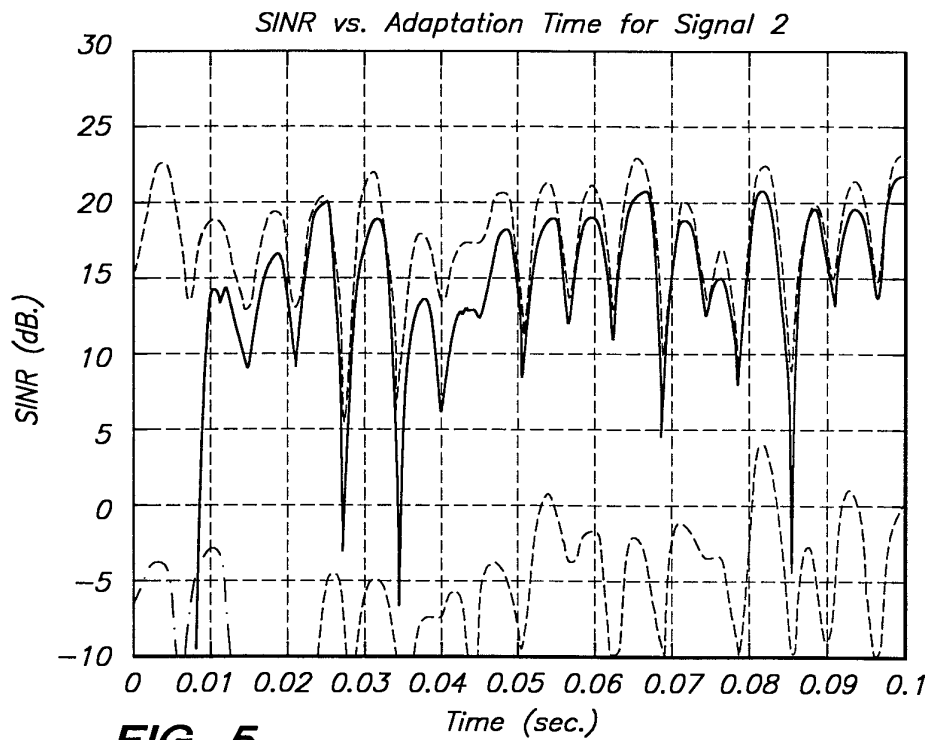


FIG. 3

SUBSTITUTE SHEET (RULE 26)



**FIG. 4**

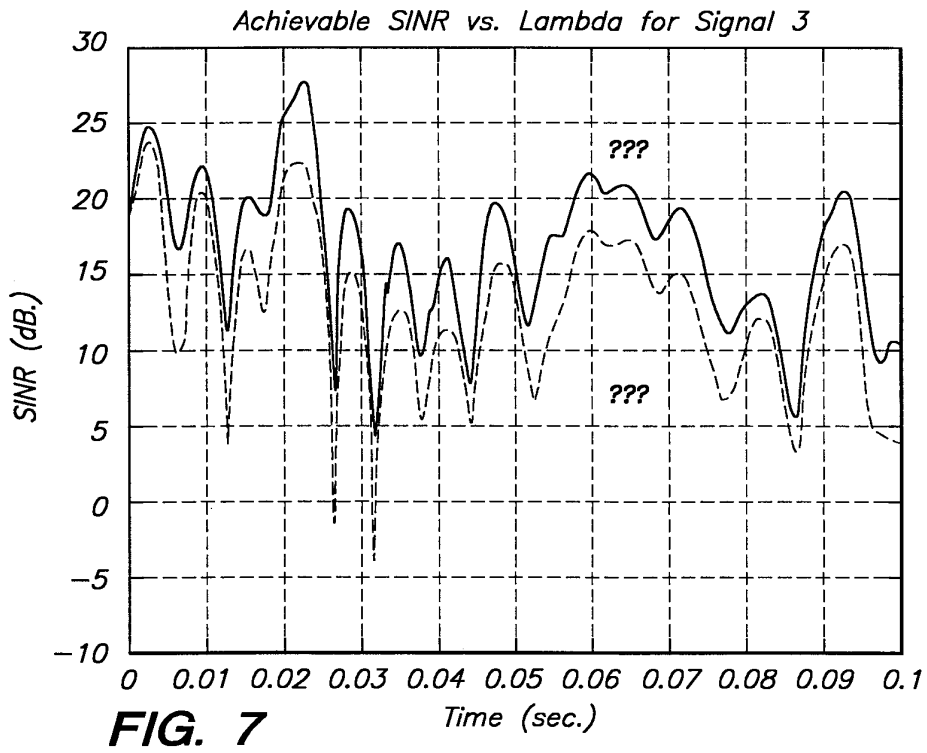
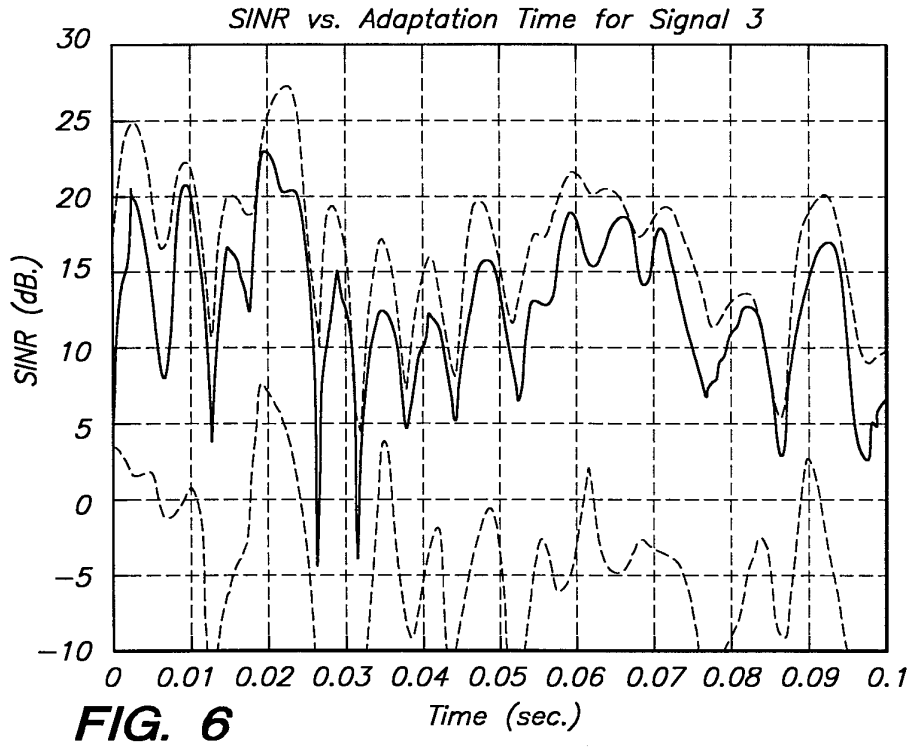


**FIG. 5**

**SUBSTITUTE SHEET (RULE 26)**



6/6



**SUBSTITUTE SHEET (RULE 26)**

# INTERNATIONAL SEARCH REPORT

International Application No

PCT/US 97/18196

**A. CLASSIFICATION OF SUBJECT MATTER**

IPC 6 H04B7/04 H01Q3/26 H01Q25/00 H04Q7/36 H04B7/005

According to International Patent Classification (IPC) or to both national classification and IPC

**B. FIELDS SEARCHED**

Minimum documentation searched (classification system followed by classification symbols)

IPC 6 H04B H04Q H01Q

Documentation searched other than minimum documentation to the extent that such documents are included in the fields searched

Electronic data base consulted during the international search (name of data base and, where practical, search terms used)

**C. DOCUMENTS CONSIDERED TO BE RELEVANT**

Category	Citation of document, with indication, where appropriate, of the relevant passages	Relevant to claim No.
X	<p>US 5 515 378 A (ROY III RICHARD H ET AL)                      7 May 1996                      * abstract *                      see column 5, line 65 - column 6, line 14                      see column 8, line 11 - line 33                      see column 8, line 45 - line 61                      see column 9, line 23 - column 10, line 21                      see column 13, line 8 - column 14, line 10                      see column 16, line 5 - line 16                      see claims 1,5; figures 4,5,8                      ---                      -/--</p>	<p>1,2,4,7, 8,10</p>

Further documents are listed in the continuation of box C.

Patent family members are listed in annex.

° Special categories of cited documents :

- "A" document defining the general state of the art which is not considered to be of particular relevance
- "E" earlier document but published on or after the international filing date
- "L" document which may throw doubts on priority claim(s) or which is cited to establish the publication date of another citation or other special reason (as specified)
- "O" document referring to an oral disclosure, use, exhibition or other means
- "P" document published prior to the international filing date but later than the priority date claimed

- "T" later document published after the international filing date or priority date and not in conflict with the application but cited to understand the principle or theory underlying the invention
- "X" document of particular relevance; the claimed invention cannot be considered novel or cannot be considered to involve an inventive step when the document is taken alone
- "Y" document of particular relevance; the claimed invention cannot be considered to involve an inventive step when the document is combined with one or more other such documents, such combination being obvious to a person skilled in the art.
- "&" document member of the same patent family

Date of the actual completion of the international search

25 May 1998

Date of mailing of the international search report

12/06/1998

Name and mailing address of the ISA

European Patent Office, P.B. 5818 Patentlaan 2  
 NL - 2280 HV Rijswijk  
 Tel. (+31-70) 340-2040, Tx. 31 651 epo nl,  
 Fax: (+31-70) 340-3016

Authorized officer

Lopez Marquez, T

**INTERNATIONAL SEARCH REPORT**

International Application No  
PCT/US 97/18196

C.(Continuation) DOCUMENTS CONSIDERED TO BE RELEVANT		
Category	Citation of document, with indication, where appropriate, of the relevant passages	Relevant to claim No.
P,X	<p>WO 97 00543 A (WATKINS JOHNSON CO ;UNIV LELAND STANFORD JUNIOR (US)) 3 January 1997</p> <p>* abstract *</p> <p>see page 4, line 15 - page 5, line 16                      see page 7, line 3 - line 16                      see page 8, line 6 - page 9, line 12                      see page 10, line 7 - line 23                      see page 11, line 5 - line 20                      see page 17, line 9 - line 20                      see figures 2,3</p> <p align="center">---</p>	1,12
A	<p>WO 95 34997 A (BODIN ROLAND STIG ;ERICSSON TELEFON AB L M (SE); FORSSEN ULF GOERA) 21 December 1995</p> <p>* abstract *</p> <p>see page 3, line 5 - page 4, line 14                      see page 5, line 22 - page 6, line 8                      see page 6, line 28 - page 7, line 7                      see page 7, line 15 - line 31                      see claim 1; figures 2,3,5</p> <p align="center">---</p>	1,7
A	<p>WO 94 09568 A (E SYSTEMS INC) 28 April 1994</p> <p>* abstract *</p> <p>see page 3, line 16 - page 4, line 16                      see page 5, line 19 - page 6, line 15                      see page 7, line 14 - page 8, line 20                      see figure 2</p> <p align="center">---</p>	1,7
A	<p>NORTH R C ET AL: "Multichannel adaptive equalization for improved performance in LOS digital radio"</p> <p>1994 IEEE MILCOM. CONFERENCE RECORD (CAT. NO.94CH34009), PROCEEDINGS OF MILCOM '94, FORT MONMOUTH, NJ, USA, 2-5 OCT. 1994, ISBN 0-7803-1828-5, 1994, NEW YORK, NY, USA, IEEE, USA,                      pages 117-122 vol.1, XP002065786                      see page 117, left-hand column, line 1 - right-hand column, line 36</p> <p align="center">-----</p>	1,7

# INTERNATIONAL SEARCH REPORT

Information on patent family members

International Application No  
PCT/US 97/18196

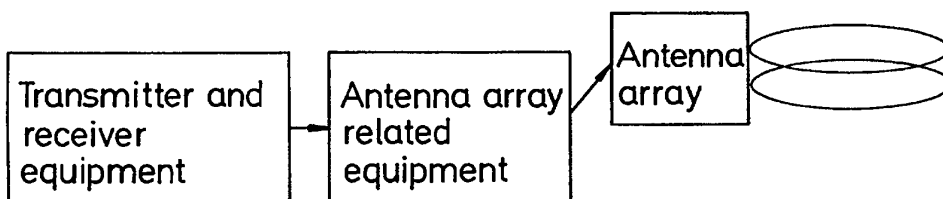
Patent document cited in search report	Publication date	Patent family member(s)	Publication date
US 5515378 A	07-05-96	AU 670766 B	01-08-96
		AU 3145493 A	19-07-93
		CA 2125571 A	24-06-93
		EP 0616742 A	28-09-94
		FI 942771 A	10-06-94
		JP 7505017 T	01-06-95
		WO 9312590 A	24-06-93
		WO 9818272 A	30-04-98
		US 5546090 A	13-08-96
		US 5625880 A	29-04-97
		US 5592490 A	07-01-97
US 5642353 A	24-06-97		
WO 9700543 A	03-01-97	AU 6034796 A	15-01-97
		EP 0832509 A	01-04-98
WO 9534997 A	21-12-95	AU 2583495 A	05-01-96
		BR 9507800 A	05-08-97
		CA 2191957 A	21-12-95
		EP 0763307 A	19-03-97
		FI 964775 A	29-11-96
		JP 10501395 T	03-02-98
WO 9409568 A	28-04-94	AU 5354294 A	09-05-94



INTERNATIONAL APPLICATION PUBLISHED UNDER THE PATENT COOPERATION TREATY (PCT)

<p>(51) International Patent Classification <sup>6</sup> : <b>H04Q 7/38</b></p>	<p><b>A2</b></p>	<p>(11) International Publication Number: <b>WO 99/21391</b> (43) International Publication Date: 29 April 1999 (29.04.99)</p>
<p>(21) International Application Number: PCT/SE98/01891 (22) International Filing Date: 20 October 1998 (20.10.98) (30) Priority Data: 9703822-8 20 October 1997 (20.10.97) SE 9703823-6 20 October 1997 (20.10.97) SE 9800869-1 17 March 1998 (17.03.98) SE (71) Applicant (for all designated States except US): RADIO DESIGN INNOVATION TJ AB [SE/SE]; P.O. Box 1223, S-164 28 Kista (SE). (72) Inventors; and (75) Inventors/Applicants (for US only): ANDERSSON, Henrik [SE/SE]; Kungsholmsgatan 16, S-112 27 Stockholm (SE). ANDERMO, Per-Göran [SE/SE]; Stejerna väg 2, S-191 45 Sollentuna (SE). (74) Agent: ALBIHNS PATENTBYRÅ MALMÖ AB; P.O. Box 4289, S-203 14 Malmö (SE).</p>		<p>(81) Designated States: AL, AM, AT, AU, AZ, BA, BB, BG, BR, BY, CA, CH, CN, CU, CZ, DE, DK, EE, ES, FI, GB, GD, GE, GH, GM, HR, HU, ID, IL, IS, JP, KE, KG, KP, KR, KZ, LC, LK, LR, LS, LT, LU, LV, MD, MG, MK, MN, MW, MX, NO, NZ, PL, PT, RO, RU, SD, SE, SG, SI, SK, SL, TJ, TM, TR, TT, UA, UG, US, UZ, VN, YU, ZW, ARIPO patent (GH, GM, KE, LS, MW, SD, SZ, UG, ZW), Eurasian patent (AM, AZ, BY, KG, KZ, MD, RU, TJ, TM), European patent (AT, BE, CH, CY, DE, DK, ES, FI, FR, GB, GR, IE, IT, LU, MC, NL, PT, SE), OAPI patent (BF, BJ, CF, CG, CI, CM, GA, GN, GW, ML, MR, NE, SN, TD, TG).  <b>Published</b> <i>Without international search report and to be republished upon receipt of that report.</i></p>

(54) Title: SEAMLESS LOBE HANDOVER



(57) Abstract

The present invention relates to a method in a telecommunication system for communication between mobile stations and base station sites in the telecommunication system. The mobile stations in said telecommunication system, preferably a cellular mobile radio system, move within a site on the same channel by use of seamless lobe or sector handover.

**FOR THE PURPOSES OF INFORMATION ONLY**

Codes used to identify States party to the PCT on the front pages of pamphlets publishing international applications under the PCT.

<b>AL</b>	Albania	<b>ES</b>	Spain	<b>LS</b>	Lesotho	<b>SI</b>	Slovenia
<b>AM</b>	Armenia	<b>FI</b>	Finland	<b>LT</b>	Lithuania	<b>SK</b>	Slovakia
<b>AT</b>	Austria	<b>FR</b>	France	<b>LU</b>	Luxembourg	<b>SN</b>	Senegal
<b>AU</b>	Australia	<b>GA</b>	Gabon	<b>LV</b>	Latvia	<b>SZ</b>	Swaziland
<b>AZ</b>	Azerbaijan	<b>GB</b>	United Kingdom	<b>MC</b>	Monaco	<b>TD</b>	Chad
<b>BA</b>	Bosnia and Herzegovina	<b>GE</b>	Georgia	<b>MD</b>	Republic of Moldova	<b>TG</b>	Togo
<b>BB</b>	Barbados	<b>GH</b>	Ghana	<b>MG</b>	Madagascar	<b>TJ</b>	Tajikistan
<b>BE</b>	Belgium	<b>GN</b>	Guinea	<b>MK</b>	The former Yugoslav Republic of Macedonia	<b>TM</b>	Turkmenistan
<b>BF</b>	Burkina Faso	<b>GR</b>	Greece	<b>ML</b>	Mali	<b>TR</b>	Turkey
<b>BG</b>	Bulgaria	<b>HU</b>	Hungary	<b>MN</b>	Mongolia	<b>TT</b>	Trinidad and Tobago
<b>BJ</b>	Benin	<b>IE</b>	Ireland	<b>MR</b>	Mauritania	<b>UA</b>	Ukraine
<b>BR</b>	Brazil	<b>IL</b>	Israel	<b>MW</b>	Malawi	<b>UG</b>	Uganda
<b>BY</b>	Belarus	<b>IS</b>	Iceland	<b>MX</b>	Mexico	<b>US</b>	United States of America
<b>CA</b>	Canada	<b>IT</b>	Italy	<b>NE</b>	Niger	<b>UZ</b>	Uzbekistan
<b>CF</b>	Central African Republic	<b>JP</b>	Japan	<b>NL</b>	Netherlands	<b>VN</b>	Viet Nam
<b>CG</b>	Congo	<b>KE</b>	Kenya	<b>NO</b>	Norway	<b>YU</b>	Yugoslavia
<b>CH</b>	Switzerland	<b>KG</b>	Kyrgyzstan	<b>NZ</b>	New Zealand	<b>ZW</b>	Zimbabwe
<b>CI</b>	Côte d'Ivoire	<b>KP</b>	Democratic People's Republic of Korea	<b>PL</b>	Poland		
<b>CM</b>	Cameroon	<b>KR</b>	Republic of Korea	<b>PT</b>	Portugal		
<b>CN</b>	China	<b>KZ</b>	Kazakstan	<b>RO</b>	Romania		
<b>CU</b>	Cuba	<b>LC</b>	Saint Lucia	<b>RU</b>	Russian Federation		
<b>CZ</b>	Czech Republic	<b>LI</b>	Liechtenstein	<b>SD</b>	Sudan		
<b>DE</b>	Germany	<b>LK</b>	Sri Lanka	<b>SE</b>	Sweden		
<b>DK</b>	Denmark	<b>LR</b>	Liberia	<b>SG</b>	Singapore		
<b>EE</b>	Estonia						

5 APPLICANT: RADIO DESIGN INNOVATION TJ AB  
TITLE OF INVENTION: SEAMLESS LOBE HANDOVER

10

**Field of invention**

The present invention relates to a method in a telecommunication system for communication between mobile stations and at least one base station site in said telecommunication system.

15

**Prior art**

Figure 1 discloses a schematic diagram of a flexible lobe shaping system. The antenna array has preferably eight antenna elements.

Each frequency channel has its own set of weights (e.g.  $W_1(1) - W_8(1)$  in Figure 1). The number of these weights is determined by the number of antenna elements used.

The number of weight sets is determined by the number of simultaneously channels. Each frequency channel has one set of weights and if SDMA (Spatial Division Multiple Access) is used there must be several weight settings for each frequency channel.

25

No. Of weight sets = No. of frequency channels  $\times$  SDMA factor.

No. of complex weights = No. of frequency channels  $\times$  SDMA factor  $\times$  number of antenna elements.

The lobe shaping system of Figure 1 is described in detail in the pending applications 9601613-4 (Method and Arrangement of Converting a Cellular Telecommunication System, Applicant: Radio Design AB), 9601615-9 (Rotating Lobe Access Method, Applicant: Radio Design AB) and 9601614-2 (Antenna System, Applicant: Radio Design AB), which applications are incorporated herein by reference.

35

A problem with this flexible lobe shaping system is that it is very expensive to implement since much equipment is used.

A less hardware-consuming and thus less expensive solution is the fixed lobe-shaping system as can be seen in Figure 2.

The object of this invention is to avoid the changing of channel when hand-over is carried out in for example the above mentioned fixed lobe-shaping system.

40

**CONFIRMATION COPY**

Another object of the invention is to avoid the changing of receiver/transmitter equipment in the base station site.

### **Brief description of the invention**

5 The above object is achieved by means of a method in a telecommunication system for communication between mobile stations and at least one base station site in said telecommunication system, wherein said mobile stations move within said base station site on a channel by use of seamless lobe/sector handover.

Handover without changing transmitter/receiver equipment implies increased  
10 capacity since it results in better trunking efficiency at the base station site.

Other features of the invention are set out in the dependent claims.

### **Brief description of the drawings**

Figure 1 is a flexible lobe-shaping system;

15 Figure 2 is a fixed lobe-shaping system according to the invention;

Figure 3 is a block diagram of the system in Figure 2;

Figure 4 discloses adjacent fixed lobes with three excited antenna panels  
according to the invention;

Figure 5 discloses a base station site with three sectors comprising one lobe  
20 each, and with one antenna per sector;

Figure 6 discloses a base station site according to the invention with three  
sectors comprising five lobes each, and one antenna array per sector;

Figure 7 discloses a base station site according to the invention with three  
sectors comprising five lobes each, and one antenna array for all sectors;

25 Figure 8 discloses a base station site according to the invention with one  
sector comprising fifteen lobes and one antenna array for said sector;

Figures 9-12 disclose different structures of the lobe shaping system  
according to the invention.

### **30 Detailed description of an embodiment of the invention**

The invention preferably refers to handover between lobes without changing channel. This implies that the mobile terminal can move within a site on the same channel by use of seamless lobe handover. The handover is seamless in the meaning that it can not be noted by the mobile user.

35 The invention will now be described with reference to Figures 3-12.

Figure 2 discloses an implementation of the block diagram in Figure 3. TRX in Figure 2 corresponds to transmitter and receiver equipment in Figures 3, 9-12. LF1 – LF<sub>n</sub> and the antennas in Figure 2 correspond to the Antenna array related equipment and the antenna array in Figures 3, 10, 12, respectively.

40 The cellular mobile radio system of the invention includes several base



station sites and mobile stations (terminals). Each base station site has one or more sectors divided into a number of fixed lobes (Figures 4-8). The base station site comprises base stations with base station transmitter equipment and a base station receiver equipment. The mobile station comprises a mobile station receiver and a mobile station transmitter. The communication in the cellular mobile radio system between a base station site and a mobile station is achieved by the following steps. As mentioned above each base station site uses a number of fixed lobes (Figures 4-8) in accordance with Figures 2, 3, 9-12. A connection is established between the base station site transmitter/receiver equipment and a mobile station. One of the lobes in one of the sectors of the base station site is used for transmission of signals between base station site transmitter/receiver and mobile station transmitter/receiver. The base station site continuously measures the signals received from the mobile station. For example the base station site determines the best lobe by comparing the signal received in actual lobe with signal received in alternative lobes. This can be carried out by comparing received signal strength or by comparing received signal to interference ratio in each lobe.

This comparison between signal strengths etc. in the lobes may imply a handover between the lobes. When the handover is performed the base station site changes utilized lobe of the base station site to another lobe of the same base station site without changing the serving transmitter and receiver equipment, i.e. the base station site uses the same transmitter/receiver equipment for the new lobe.

In another embodiment of the invention the base station site also changes transmitter/receiver equipment when changing lobe.

Thus, the channel is not changed when changing lobe. It should be realized that with channel we mean frequency, time slot, CDMA-coding etc. It should also be realized that instead of effecting handover between lobes as mentioned above, handover between sectors can also be achieved in the same manner.

A number of different handover situations will now be described with reference particularly to Figures 5-12. First the concept "base station site" will be explained with reference to Figure 6. The concept "base station site" in Figure 6 is defined as the covering area of the three sectors, and the base station site includes the three antenna arrays which normally are controlled by three base stations, i.e. one base station for each antenna array.

As mentioned above handover (HO) can be performed between different lobes and different sectors in a base station site. As disclosed in Figure 5 a base station site can consist of three different physical antennas, each connected to a base station, wherein handover can be performed between these antennas (base stations). This is the case in Figures 5, 11 in which lobe/sector handover is performed changing from sector 1 to sector 2. The transmitter/receiver equipment (TRX) controlling sector 1 is changed during handover to another transmitter/re-

ceiver equipment for sector 2. However, the same channel is used.

Another possibility is described in Figures 5, 9. In this case lobe/sector handover is performed changing from sector 1 to sector 2 but the same transmitter/receiver equipment of the base station site is used. The same channel or  
5 another channel can be used.

In Figures 3 and 6, lobe handover within a sector is performed without changing transmitter/receiver equipment. Same or changed channel can be used.

In Figures 6 and 12 sector/lobe handover is performed changing from one sector and corresponding TRX1 to another sector and corresponding TRX2. Same  
10 or changed channel can be used.

In Figures 3 and 7 lobe handover between lobes 4 and 5 is either performed within a sector or a lobe/sector handover is performed between sectors 6 and 7, wherein handover is performed from lobe 8 in sector 6 to lobe 9 in sector 7. In this case the same TRX equipment is used and the same or changed channel can be  
15 used.

In Figures 6, 10 lobe/sector handover is performed changing from one sector to another sector but the same transmitter/receiver equipment of the base station site is used.

The above is only to be considered as a preferable embodiment, and the scope  
20 of the invention is only limited by the following claims.

## CLAIMS

1. A method in a telecommunication system for communication between mobile stations and at least one base station site in said telecommunication system, **characterized** in that said mobile stations move within said at least one base station site on a channel by use of seamless lobe handover.
2. A method as claimed in claim 1, **characterized** in that said telecommunication system includes said at least one base station site having one or more sectors each divided into a number of fixed lobes comprising the steps of:
- establishing a connection between a base station site transmitter/receiver equipment in said at least one base station site and a mobile station;
  - transmitting signals from said base station site transmitter equipment to said mobile station receiver and transmitting signals from said mobile station transmitter to said base station site receiver equipment by utilizing one of said lobes in one of the sectors of said base station;
  - changing said utilized lobe of said at least one base station site to another lobe of said at least one base station site without changing transmitter/receiver equipment of said base station site.
3. A method as claimed in claim 1, **characterized** in that said telecommunication system includes said at least one base station site having one or more sectors each divided into a number of fixed lobes comprising the steps of:
- establishing a connection between a base station site transmitter/receiver equipment in said at least one base station site and a mobile station;
  - transmitting signals from said base station site transmitter equipment to said mobile station receiver and transmitting signals from said mobile station transmitter to said base station site receiver equipment by utilizing one of said lobes in one of the sectors of said base station;
  - changing said utilized lobe and corresponding transmitter/receiver equipment (TRX1) of said at least one base station site to another lobe and corresponding transmitter/receiver equipment (TRX2) of said base station site.
4. A method as claimed in any of the preceding claims, **characterized** in that an antenna array and its supporting equipment is used to form fixed lobes.
5. A method as claimed in any of the preceding claims, **characterized** in that the channel is not changed when changing lobe.
6. A method as claimed in claim 5, **characterized** in that the change of the lobe is made without any signalling or channel order to and from said base station site to control the change of the lobe.
7. A method as claimed in any of claims 1-4, **characterized** in that said channel is changed when changing lobe.
8. A method as claimed in any of the preceding claims, **characterized** in that equipment in said base station site determines the best lobe by comparing signals

received in actual lobe with signals received in adjacent lobes.

9. A method as claimed in claim 8, **characterized** in that signals are compared by detecting received signal strength.

10. A method as claimed in claim 8, **characterized** in that signals are compared by evaluating received signal to interference ratio.

11. A method in a telecommunication system for communication between mobile stations and at least one base station site in said telecommunication system, **characterized** in that said mobile stations move within said at least one base station site on a channel by use of seamless sector handover.

12. A method as claimed in claim 11, **characterized** in that said telecommunication system includes said at least one base station site having a plurality of sectors comprising the steps of:

- establishing a connection between a base station site transmitter/receiver equipment in said at least one base station site and a mobile station;

- transmitting signals from said base station site transmitter to said mobile station receiver and transmitting signals from said mobile station transmitter to said base station site receiver equipment by utilizing one of the sectors in said base station site;

- changing utilized sector in said base station site to another sector in said base station site without changing transmitter/receiver equipment of said base station site.

13. A method as claimed in claim 11, **characterized** in that said telecommunication system includes said at least one base station site having a plurality of sectors comprising the steps of:

- establishing a connection between a base station site transmitter/receiver equipment and a mobile station;

- transmitting signals from said base station site transmitter to said mobile station receiver and transmitting signals from said mobile station transmitter to said base station site receiver equipment by utilizing one of the sectors in said base station site;

- changing utilized sector and corresponding transmitter/receiver equipment (TRX1) of said at least one base station site to another sector and corresponding transmitter/receiver equipment (TRX2) of said at least one base station site.

14. A method as claimed in any of claims 11-13, **characterized** in that said channel is not changed when changing sector.

15. A method as claimed in any of claims 11-14, **characterized** in that said change of sector is made without any signalling or channel order to and from said base station site to control said change of sector.

16. A method as claimed in any of claims 11-13, **characterized** in that said channel is changed when changing sector.

17. A method as claimed in any of claims 11-16, **characterized** in that equipment in said base station site determines the best sector by comparing signals received in actual sector with signals received in adjacent sectors.

18. A method as claimed in claim 17, **characterized** in that said signals are  
5 compared by detecting received signal strength.

19. A method as claimed in claim 17, **characterized** in that said signals are compared by evaluating received signal to interference ratio.

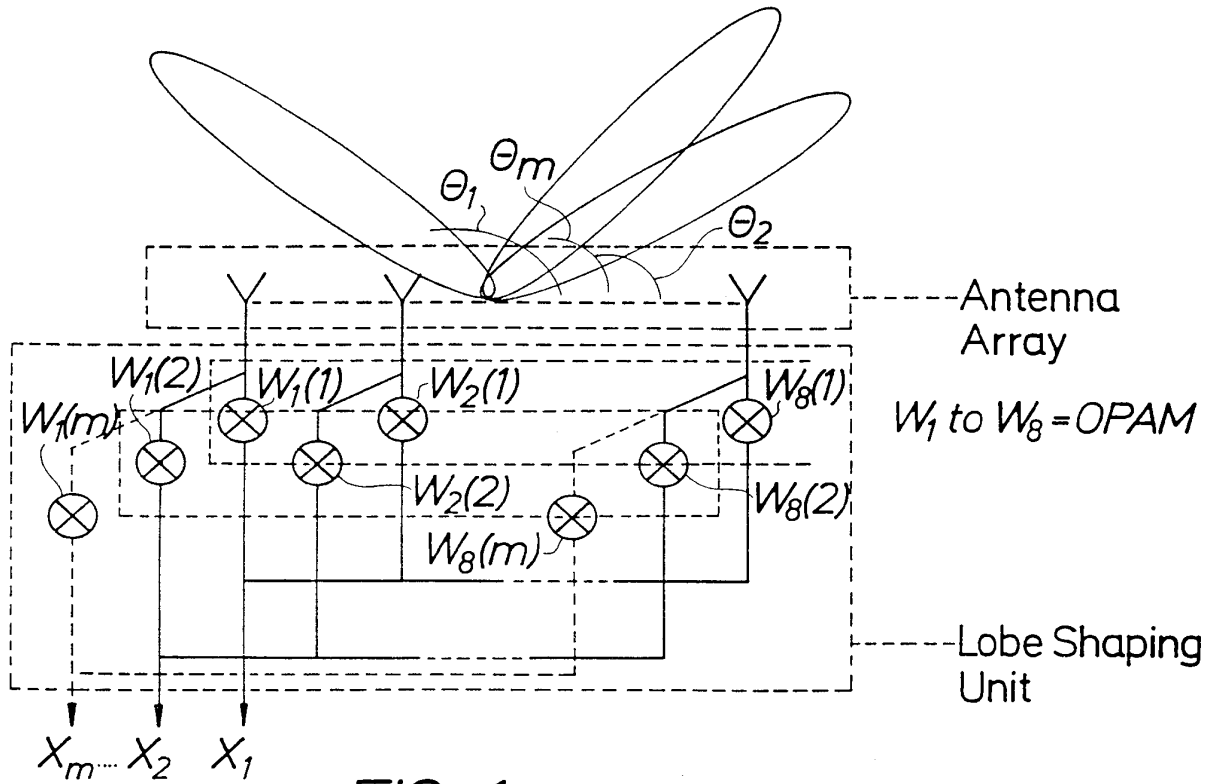


FIG. 1

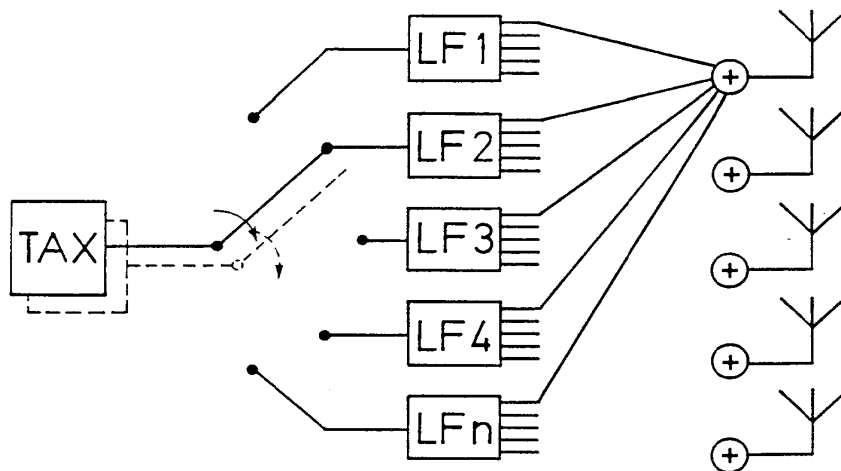


FIG. 2

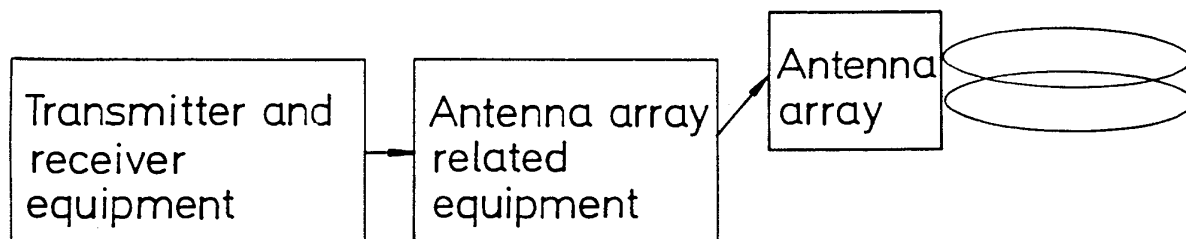


FIG. 3

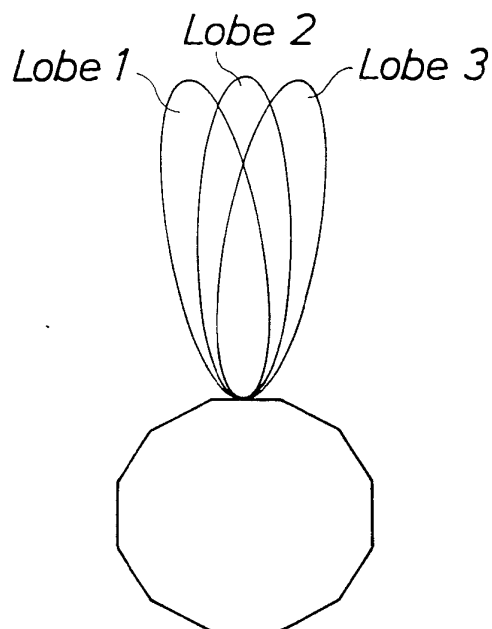


FIG. 4

SUBSTITUTE SHEET (RULE 26)

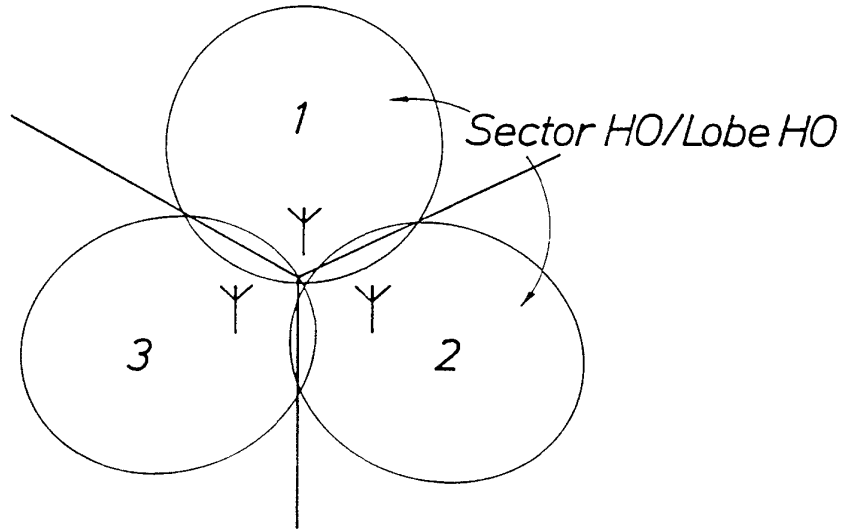


FIG. 5

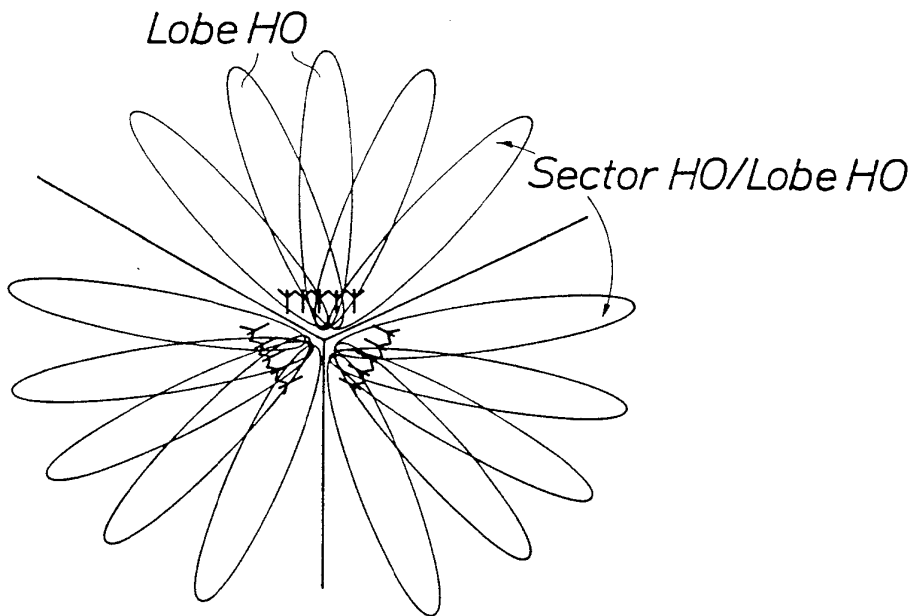


FIG. 6

SUBSTITUTE SHEET (RULE 26)



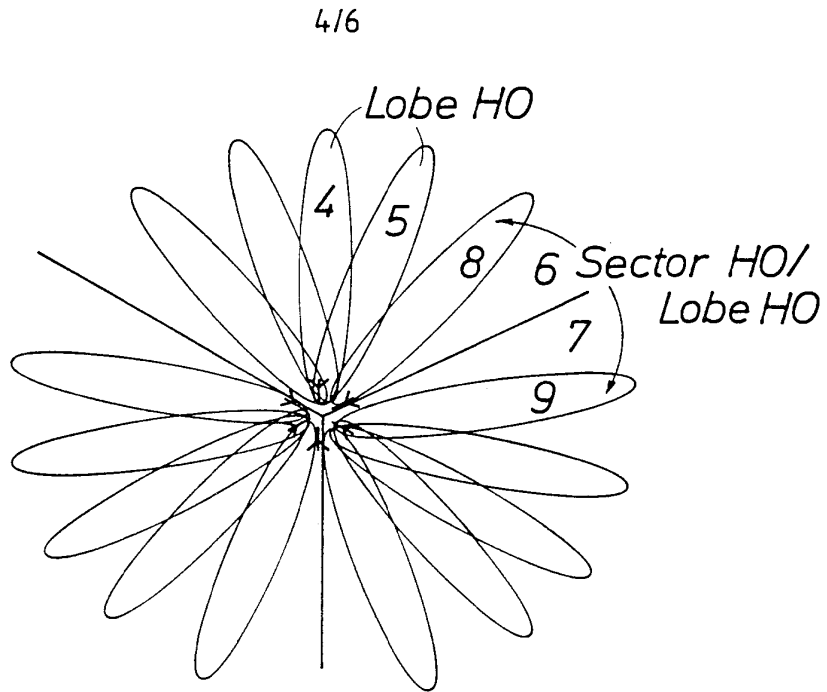


FIG. 7

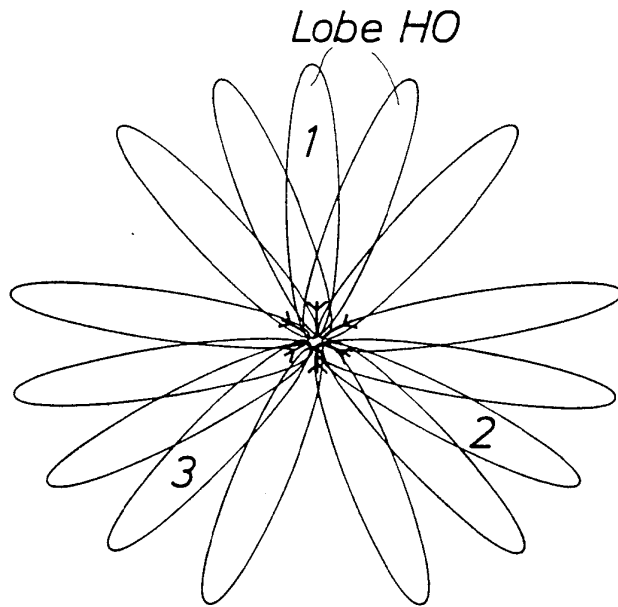


FIG. 8

SUBSTITUTE SHEET (RULE 26)

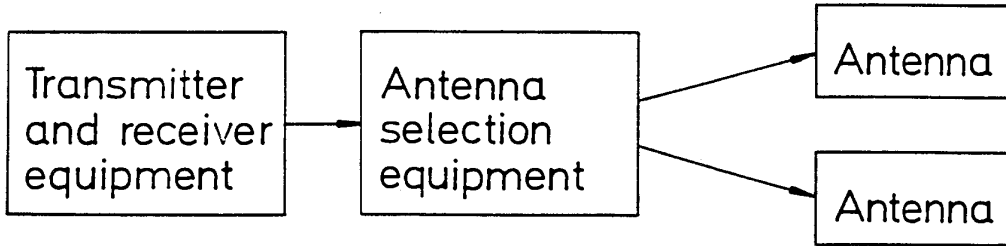


FIG. 9

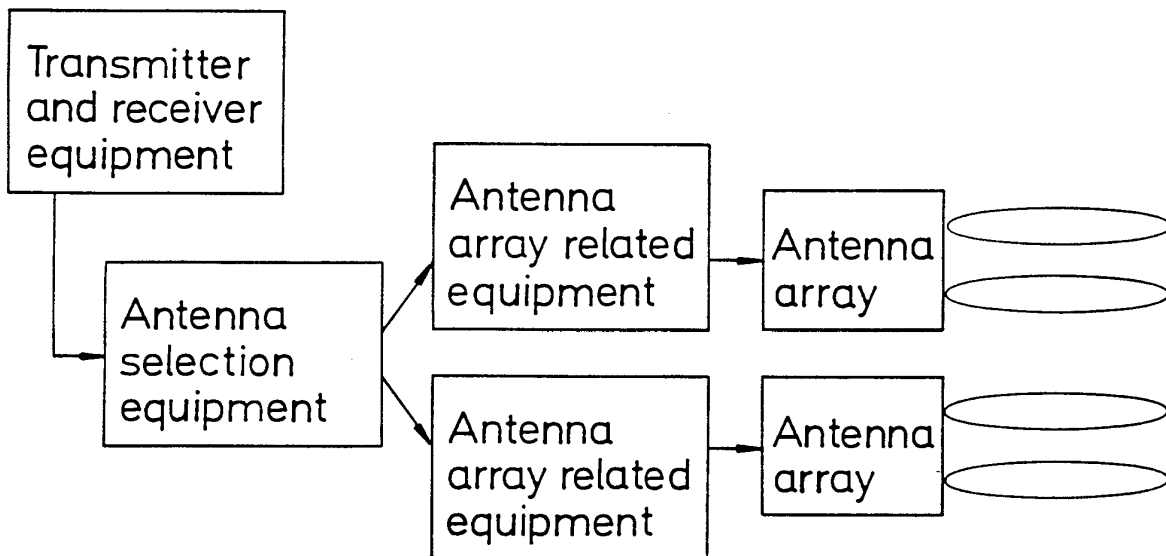


FIG. 10

SUBSTITUTE SHEET (RULE 26)

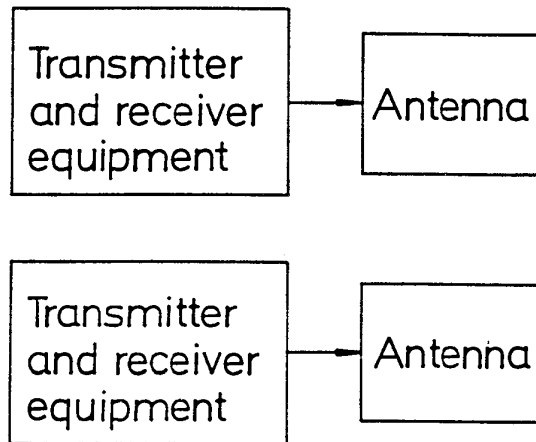


FIG. 11

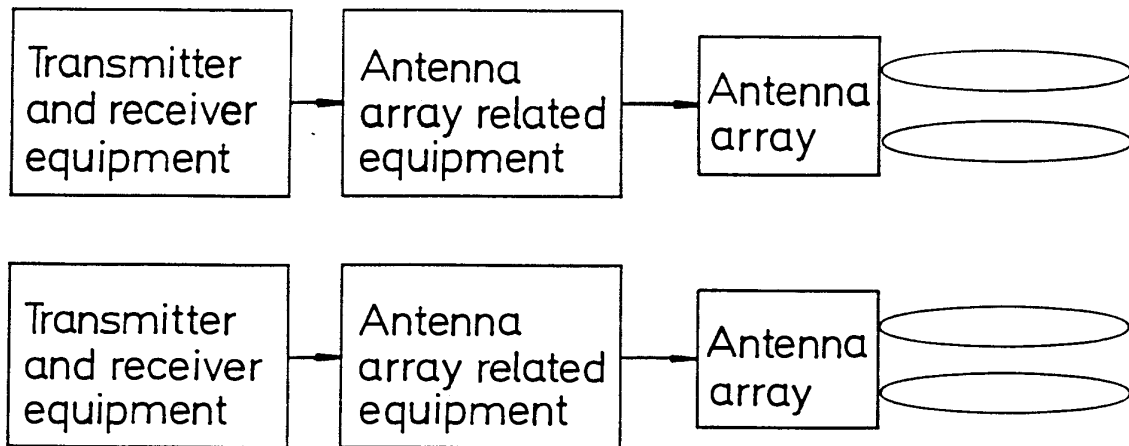
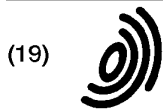


FIG. 12

SUBSTITUTE SHEET (RULE 26)



Europäisches Patentamt  
 European Patent Office  
 Office européen des brevets



(11) EP 0 817 517 A1

(12)

**EUROPEAN PATENT APPLICATION**

(43) Date of publication:  
 07.01.1998 Bulletin 1998/02

(51) Int. Cl.<sup>6</sup>: H04Q 7/38, H04B 7/26

(21) Application number: 97110306.4

(22) Date of filing: 24.06.1997

(84) Designated Contracting States:  
 AT BE CH DE DK ES FI FR GB GR IE IT LI LU MC  
 NL PT SE

(72) Inventors:  
 • Nakamura, Takehiro  
 Yokosuka-shi, Kanagawa (JP)  
 • Sato, Takaaki  
 Yokohama-shi, Kanagawa (JP)

(30) Priority: 24.06.1996 JP 163170/96

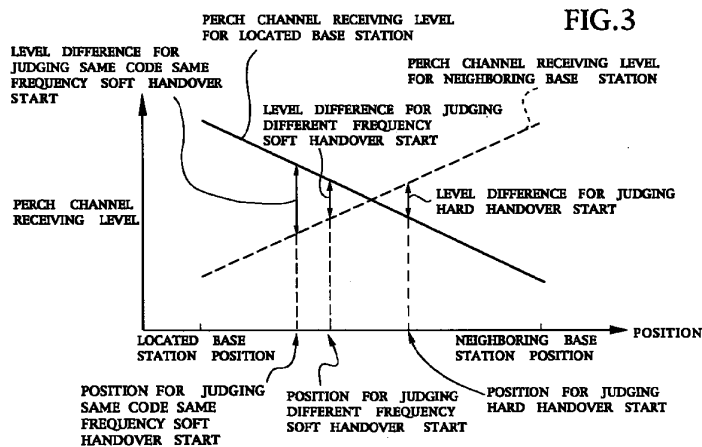
(71) Applicant:  
 NTT MOBILE COMMUNICATIONS NETWORK  
 INC.  
 Minato-ku, Tokyo (JP)

(74) Representative:  
 von Fischern, Bernhard, Dipl.-Ing. et al  
 Hoffmann - Eitle,  
 Patent- und Rechtsanwälte,  
 Arabellastrasse 4  
 81925 München (DE)

**(54) Handover type judgement scheme for CDMA mobile communication system**

(57) A handover type judgement scheme for a CDMA mobile communication system which is capable of judging an appropriate type of handover from multiple types of handover available. At the mobile station, one type of handover for which a handover start condition is weakest among available types of handover is judged.

Then, whether the handover start condition for that one type of handover is satisfied or not is checked, and each base station for carrying out that one type of handover is notified when the handover start condition for said one type of handover is satisfied.



EP 0 817 517 A1

**Description****BACKGROUND OF THE INVENTION****FIELD OF THE INVENTION**

The present invention relates to a handover type judgement scheme for a CDMA (Code Division Multiple Access) mobile communication system which is capable of carrying out any of multiple types of handover with different handover start conditions at a time of handover in which a mobile station moves from a currently communicating base station to another base station.

**DESCRIPTION OF THE BACKGROUND ART**

In the conventional mobile communication system such as PDC (Personal Digital Cellular) system that is currently providing the mobile communication service in Japan, there is only one available type of handover called hard handover.

In contrast, in the CDMA mobile communication system, the soft handover is also available in addition to the hard handover, and this soft handover further includes multiple types of soft handovers such as the same code same frequency soft handover and the different frequency soft handover. Here, these multiple types of handovers are associated with mutually different handover start conditions.

In order for each mobile station to carry out the handover properly, each base station is transmitting the perch channel (or the pilot channel). The mobile station receives the perch channel transmitted from each base station of each nearby cell, compares the receiving level of the perch channel received from each nearby cell with the receiving level of the perch channel of a currently located cell, and judges the start of the handover according to the obtained difference.

Here, as already mentioned above, the available types of handover includes the hard handover, the same code same frequency soft handover, and the different frequency soft handover, and the handover start conditions for these three types of handover are as indicated in Fig. 3. As can be seen from Fig. 3, when an influence on the radio channel capacity is taken into account, the handover start condition is weakest for the same code same frequency soft handover, second weakest for the different frequency soft handover, and strongest for the hard handover.

As already mentioned above, the conventional mobile communication system has been designed to use only one type of handover, so that there has been no means for Judging an appropriate type of handover to be executed out of multiple types of handover.

**SUMMARY OF THE INVENTION**

It is therefore an object of the present invention to

provide a handover type judgement scheme for a CDMA mobile communication system which is capable of judging an appropriate type of handover from multiple types of handover available.

5 According to one aspect of the present invention there is provided a handover type judgement method for a CDMA mobile communication system which is capable of carrying out any of multiple types of handover with different handover start conditions, the method comprising the steps of: judging one type of handover for which a handover start condition is weakest among available types of handover at a mobile station; and checking whether the handover start condition for said one type of handover is satisfied or not at the mobile station, and notifying each base station for carrying out said one type of handover when the handover start condition for said one type of handover is satisfied.

10 According to another aspect of the present invention there is provided a CDMA mobile communication system for carrying out any of multiple types of handover with different handover start conditions, comprising: a plurality of base stations; and at least one mobile station having: a judging unit for judging one type of handover for which a handover start condition is weakest among available types of handover; and a checking unit for checking whether the handover start condition for said one type of handover is satisfied or not, and notifying each base station for carrying out said one type of handover when the handover start condition for said one type of handover is satisfied.

15 According to another aspect of the present invention there is provided a mobile station apparatus for use as a mobile station in a CDMA mobile communication system for carrying out any of multiple types of handover with different handover start conditions, the apparatus comprising: a judging unit for judging one type of handover for which a handover start condition is weakest among available types of handover; and a checking unit for checking whether the handover start condition for said one type of handover is satisfied or not, and notifying each base station for carrying out said one type of handover when the handover start condition for said one type of handover is satisfied.

20 According to another aspect of the present invention there is provided a base station apparatus for use as a base station in a CDMA mobile communication system for carrying out any of multiple types of handover with different handover start conditions, the apparatus comprising: a measuring unit for measuring a radio channel state for each cell/sector of the base station; a determining unit for determining each impossible type of handover that cannot be carried out for each cell/sector by the base station according to the radio channel state measured by the measuring unit; and a notifying unit for notifying an information indicating said each impossible type of handover to a mobile station, so that at a time of handover with respect to the base station, the mobile station judges one type of handover for which a hando-

ver start condition is weakest among available types of handover which include said multiple types of handover except for said each impossible type of handover according to said information, checks whether the handover start condition for said one type of handover is satisfied or not, and notifies each base station for carrying out said one type of handover when the handover start condition for said one type of handover is satisfied.

According to another aspect of the present invention there is provided a base station apparatus for use as a base station in a CDMA mobile communication system for carrying out any of multiple types of handover with different handover start conditions including a same code same frequency soft handover and a different frequency soft handover, the apparatus comprising: a measuring unit for measuring an interference receiving level or a total receiving level of each frequency bandwidth that is implemented at the base station for each cell/sector of the base station; and a notifying unit for notifying an information indicating that one frequency bandwidth cannot be used for one cell/sector to a mobile station, when a measured value for said one frequency bandwidth and said one cell/sector is greater than a prescribed threshold value, so that at a time of handover with respect to said one cell/sector while the mobile station is currently using said one frequency bandwidth as indicated by said information, the mobile station judges the different frequency soft handover as having a weakest handover start condition among available types of handover, checks whether the handover start condition for the different frequency soft handover is satisfied or not without checking the handover start condition for the same code same frequency soft handover with respect to said one cell/sector, and notifies each base station for carrying out the different frequency soft handover when the handover start condition for the different frequency soft handover is satisfied.

Other features and advantages of the present invention will become apparent from the following description taken in conjunction with the accompanying drawings.

#### BRIEF DESCRIPTION OF THE DRAWINGS

Fig. 1 is a block diagram of a mobile station apparatus for realizing a handover type judgement scheme for a CDMA mobile communication system according to the present invention.

Fig. 2 is a block diagram of a base station apparatus for realizing a handover type judgement scheme for a CDMA mobile communication system according to the present invention.

Fig. 3 is a graph for explaining handover start conditions for three types of handover used in a handover type judgement scheme for a CDMA mobile communication system according to the present invention.

#### DETAILED DESCRIPTION OF THE PREFERRED EMBODIMENTS

Referring now to Fig. 1 to Fig. 3, various embodiments of a handover type judgement scheme for a CDMA mobile communication system according to the present invention will be described in detail.

Fig. 1 and Fig. 2 respectively show a mobile station apparatus and a base station apparatus for realizing the handover type judgement scheme for a CDMA mobile communication system according to the present invention.

The mobile station apparatus of Fig. 1 has an antenna 1 for receiving radio signals from base stations and transmitting radio signals to base stations. The signals from base stations received by the antenna 1 are supplied to a demodulation unit 7 through a duplexer 3 and a reception unit 5, and applied with the despreading using a spread code and the usual demodulation at this demodulation unit 7. The demodulated signals are then supplied to a decoding unit 9 which decodes the demodulated signals into transmission signals and control signals. The decoded control signals are supplied to a control unit 11, while the decoded transmission signals are supplied to a man-machine interface (not shown).

On the other hand, transmission signals such as speech signals from the man-machine interface are supplied to an encoding unit 13 along with the control signals from control unit 11, encoded at this encoding unit 13, applied with the primary modulation and the spreading using a spread code at a modulation unit 15, and then transmitted to base stations from the antenna 1 through a transmission unit 17 and the duplexer 3.

In addition, the mobile station apparatus of Fig. 1 also has a memory 51 connected to the control unit 11, which stores different handover start conditions for multiple types of handover along with an order of weakness among these handover start conditions, where the multiple types of handover includes the same code same frequency soft handover, the different frequency soft handover, and the hard handover. The CDMA mobile communication system of this embodiment is capable of carrying out any of these multiple types of handover. In addition, the memory 51 is also capable of storing an unexecutable handover type which is to be notified from a base station as will be described in detail below.

Moreover, the mobile station apparatus of Fig. 1 also has a measurement unit 53 provided between the reception unit 5 and the control unit 11, which measures a total receiving level or an interference receiving level of a frequency bandwidth by which this mobile station is currently communicating with base stations, and supplies the measured value to the control unit 11.

The base station apparatus of Fig. 2 has an antenna 21 for receiving radio signals from mobile stations and transmitting radio signals to mobile stations. The signals from mobile stations received by the

antenna 21 are supplied to a demodulation unit 27 through a duplexer 23 and a reception unit 25, and applied with the despreading using a spread code and the usual demodulation at this demodulation unit 27. The demodulated signals are then supplied to a decoding unit 29 which decodes the demodulated signals into transmission signals and control signals. The decoded control signals are supplied to a control unit 31, while the decoded transmission signals are transmitted to an upper level exchange station (not shown) through a wire transmission line transmission unit 39.

On the other hand, transmission signals the exchange station are received by a wire transmission line reception unit 41, and decomposed into the transmission signals and the control signals. The decomposed control signals are supplied to the control unit 31, while the decomposed transmission signals are encoded at an encoding unit 33, applied with the primary modulation and the spreading using a spread code at a modulation unit 15, and then transmitted to mobile stations from the antenna 21 through a transmission unit 7 and the duplexer 23.

Moreover, the base station apparatus of Fig. 2 also has a measurement unit 55 provided between the reception unit 25 and the control unit 31, which measures a radio channel state for each cell/sector, or a total receiving level or an interference receiving level of each frequency bandwidth implemented at this base station for each cell/sector, and supplies the measured value to the control unit 31.

In the mobile communication system having the mobile station device of Fig. 1 and the base station of Fig. 2 as described above, it is possible to carry out any of the multiple types of handover including the same code same frequency soft handover, the different frequency soft handover, and the hard handover, under different handover start conditions as indicated in Fig. 3.

Now, in one embodiment of a handover type judgement scheme according to the present invention, the mobile station judges and selects a handover type which has the weakest handover start condition among these multiple types of handover as the most effective one from a viewpoint of the radio channel capacity, and when the handover start condition for the selected handover type is satisfied, the mobile station notifies this fact to the base station so as to carry out the selected type of handover.

As can be seen from a level difference for judging the handover start for each handover type indicated in Fig. 3, the handover start condition is weakest for the same code same frequency soft handover, second weakest for the different frequency soft handover, and strongest for the hard handover among three types of handover available in this mobile communication system, and as already mentioned above, the memory 51 provided in the mobile station device stores these different handover start conditions for multiple types of handover along with an order of weakness among these

handover start conditions.

At the mobile station, normally, whether the weakest handover start condition among the handover start conditions for multiple types of handover as stored in the memory 51, that is the handover start condition for the same code same frequency soft handover, is satisfied or not is regularly checked by the control unit 11, and when this handover start condition is satisfied, this fact is notified from the control unit 11 to the base station in a form of a control signal which is transmitted through the encoding unit 13, the modulation unit 15, the transmission unit 17, and the duplexer 3, so as to start the same code same frequency soft handover.

In addition, there are cases in which a certain base station cannot use a particular frequency or cannot carry out the soft handover so that only the hard handover is possible, and when a particular type of handover cannot be carried out at a certain base station because of the reason not changing in time such as that related to the system configuration, this base station notifies this fact to the mobile station in advance. Then, the mobile station judges and selects a handover type which has the weakest handover start condition among the available types of handover excluding the notified type of handover that cannot be carried out at the base station, and when the handover start condition for the selected handover type is satisfied, the mobile station notifies this fact to the base station so as to carry out the selected type of handover.

As one concrete example of this embodiment, the base station notifies the available frequency bandwidth of each surrounding cell/sector to the mobile station in advance, and the mobile station stores this available frequency bandwidth of each surrounding cell/sector notified from the base station into the memory 51. Then, the mobile station identifies each cell/sector at which the same code same frequency soft handover cannot be carried out according to the stored available frequency bandwidth, and makes the judgement of the handover start condition for the different frequency soft handover with respect to each identified cell/sector, without making the judgement of the handover start condition for the same code same frequency soft handover. Then, when the handover start condition for the different frequency soft handover is satisfied, the mobile station notifies this fact to the base station.

As another concrete example of this embodiment, when a certain base station cannot carry out the soft handover so that only the hard handover is possible, this base station notifies this fact to the mobile station in advance, and the mobile station stores this notification into the memory 51. Then, according to this stored notification, the mobile station makes the judgement of the handover start condition for the hard handover with respect to this base station, without making the judgement of the handover start condition for the soft handover. Then, when the handover start condition for the hard handover is satisfied, the mobile station notifies

this fact to this base station.

Next, in another embodiment of a handover type judgement scheme according to the present invention, the mobile station measures the downlink radio channel state at the measurement unit 53, and judges whether it is possible to carry out each type of handover or not at the control unit 11 according to the measured value, in order to cope with a case in which a particular type of handover cannot be carried out because of the reason changing in time, as in a case where the interference receiving level of the frequency bandwidth currently used for the communication at the mobile station is greater than a prescribed threshold level and the radio channel capacity of this frequency bandwidth is already full so that the same code same frequency soft handover using this frequency bandwidth cannot be carried out.

Then, the mobile station judges and selects a handover type which has the weakest handover start condition among the available types of handover excluding the type of handover that has been judged as not possible to carry out, and when the handover start condition for the selected handover type is satisfied, the mobile station notifies this fact to the base station so as to carry out the selected type of handover.

As one concrete example of this embodiment, the mobile station measures the interference receiving level or the total receiving level of the frequency bandwidth which is currently used for the communication at the measurement unit 53, and compares the measured value with a prescribed threshold value at the control unit 11. Then, when the measured value is greater than the prescribed threshold value, the mobile station makes the judgement of the handover start condition for the different frequency soft handover, without making the judgement of the handover start condition for the same code same frequency soft handover using this frequency bandwidth, and when the handover start condition for the different frequency soft handover is satisfied, the mobile station notifies this fact to this base station.

Next, in another embodiment of a handover type judgement scheme according to the present invention, in order to cope with a case in which a particular type of handover cannot be carried out because of the reason changing in time such as the capacity overflow as described above, each base station measures the uplink radio channel state for each cell/sector at the measurement unit 55, judges whether it is possible to carry out each type of handover or not according to the measured value, and notifies an information on this judgement result to the surrounding base stations. Then, each surrounding base station notifies this information to the currently communicating mobile station.

Then, the mobile station judges and selects a handover type which has the weakest handover start condition among the available types of handover excluding the type of handover that has been judged as

not possible to carry out with respect to a relevant cell/sector according to the notified information, and when the handover start condition for the selected handover type is satisfied, the mobile station notifies this fact to the base station so as to carry out the selected type of handover.

As one concrete example of this embodiment, each base station measures the interference receiving level or the total receiving level of each frequency bandwidth that is implemented at that base station, for each cell/sector at the measurement unit 55, and compares the measured value with a prescribed threshold value at the control unit 31. Then, when the measured value is greater than the prescribed threshold value, each mobile station notifies the fact that the frequency bandwidth corresponding to this measured value cannot be used to the surrounding base stations. Then, each surrounding base station notifies this notified frequency bandwidth that cannot be used to the currently communicating mobile station.

At the mobile station which received this notification and which is using this notified frequency bandwidth, the judgement of the handover start condition for the different frequency soft handover is made with respect to a relevant cell/sector, without making the judgement of the handover start condition for the same code same frequency soft handover using this frequency bandwidth, and when the handover start condition for the different frequency soft handover is satisfied, the mobile station notifies this fact to this base station.

Note here that the notification from the base station in this embodiment may be made only with respect to the mobile station which is currently using the relevant frequency bandwidth for the communication.

As described, according to the handover type judgement scheme of the present invention, the mobile station judges and selects a handover type which has the weakest handover start condition among the available multiple types of handover, and when the handover start condition for the selected handover type is satisfied, this fact is notified to the base station so as to carry out the selected type of handover. Consequently, the each type of handover among the available multiple types of handover can be carried out appropriately according to its handover start condition.

In addition, in a case where a particular type of handover cannot be carried out because of either the reason not changing in time such as that related to the system configuration or the reason changing in time such as the capacity overflow, this fact is notified in advance or such a case is detected. Then, the mobile station judges and selects a handover type which has the weakest handover start condition among the available types of handover excluding this particular type of handover that cannot be carried out, and when the handover start condition for the selected handover type is satisfied, this fact is notified to the base station so as to carry out the selected type of handover. Conse-



quently, it is possible to realize an efficient handover type judgement scheme by eliminating an unnecessary judgement of the handover start condition for that particular type of handover that cannot be carried out as well as an unnecessary increase of the traffic due to the notification resulting from such an unnecessary judgement.

It is to be noted that, besides those already mentioned above, many modifications and variations of the above embodiments may be made without departing from the novel and advantageous features of the present invention. Accordingly, all such modifications and variations are intended to be included within the scope of the appended claims.

### Claims

1. A handover type judgement method for a CDMA mobile communication system which is capable of carrying out any of multiple types of handover with different handover start conditions, the method comprising the steps of:

judging one type of handover for which a handover start condition is weakest among available types of handover at a mobile station; and

checking whether the handover start condition for said one type of handover is satisfied or not at the mobile station, and notifying each base station for carrying out said one type of handover when the handover start condition for said one type of handover is satisfied.

2. The method of claim 1, further comprising the step of:

notifying from one base station to the mobile station in advance a particular type of handover among said multiple types of handover that cannot be carried out at said one base station; wherein at a time of handover with respect to said one base station, the judging step judges said one type of handover from said available types of handover which include said multiple types of handover except for said particular type of handover.

3. The method of claim 1, further comprising the steps of:

notifying from one base station to the mobile station in advance an available frequency bandwidth for each surrounding cell/sector of said one base station; and determining one cell/sector for which a same code same frequency soft handover cannot be carried out according to the available frequency

bandwidth for said one cell/sector as notified by the notifying step;

wherein said multiple types of handover includes a same code same frequency soft handover and a different frequency soft handover, and at a time of handover with respect to said one cell/sector determined by the determining step, the judging step judges the different frequency soft handover as said one type of handover so that the checking step does not check the handover start condition for the same code same frequency soft handover with respect to said one cell/sector.

4. The method of claim 1, further comprising the steps of:

notifying from one base station to the mobile station in advance an information as to whether a soft handover is possible or not with respect to each surrounding cell/sector of said one base station; and determining one cell/sector for which the soft handover is not possible according to the information for said one cell/sector as notified by the notifying step;

wherein said multiple types of handover includes a soft handover and a hard handover, and at a time of handover with respect to said one cell/sector determined by the determining step, the judging step judges the hard handover as said one type of handover so that the checking step does not check the handover start condition for the soft handover with respect to said one cell/sector.

5. The method of claim 1, further comprising the steps of:

measuring a radio channel state at the mobile station; and determining each impossible type of handover that cannot be carried out by the mobile station according to the radio channel state measured by the measuring step;

wherein the judging step judges said one type of handover from said available types of handover which include said multiple types of handover except for said each impossible type of handover.

6. The method of claim 1, further comprising the step of:

measuring an interference receiving level or a total receiving level of a frequency bandwidth currently used for communication at the mobile station;

wherein said multiple types of handover includes a same code same frequency soft handover and a different frequency soft handover, and when a measured value obtained by the measuring step is greater than a prescribed threshold value, the judging step judges the different frequency soft handover as said one type of handover so that the checking step does not check the handover start condition for the same code same frequency soft handover.

7. The method of claim 1, further comprising the steps of:

measuring a radio channel state for each cell/sector of each base station;  
determining each impossible type of handover that cannot be carried out for each cell/sector by said each base station according to the radio channel state measured by the measuring step; and  
notifying an information indicating said each impossible type of handover from said each base station to the mobile station;

wherein at a time of handover with respect to said each base station, the judging step judges said one type of handover from said available types of handover which include said multiple types of handover except for said each impossible type of handover according to said information.

8. The method of claim 7, wherein at the notifying step, said each base station notifies said information to surrounding base stations and the mobile station receives said information via one of said surrounding base stations with which the mobile station is currently communicating.
9. The method of claim 1, further comprising the steps of:

measuring an interference receiving level or a total receiving level of each frequency bandwidth that is implemented at each base station for each cell/sector of said each base station; and  
notifying an information indicating that one frequency bandwidth cannot be used for one cell/sector from said each base station to the mobile station, when a measured value for said one frequency bandwidth and said one cell/sector is greater than a prescribed threshold value;

wherein said multiple types of handover includes a same code same frequency soft handover and a different frequency soft handover, and at a time of handover with respect to

said one cell/sector while the mobile station is currently using said one frequency bandwidth as indicated by said information, the judging step judges the different frequency soft handover as said one type of handover so that the checking step does not check the handover start condition for the same code same frequency soft handover with respect to said one cell/sector.

10. The method of claim 9, wherein at the notifying step, said each base station notifies said information to surrounding base stations and the mobile station receives said information via one of said surrounding base stations with which the mobile station is currently communicating.

11. A CDMA mobile communication system for carrying out any of multiple types of handover with different handover start conditions, comprising:

a plurality of base stations; and  
at least one mobile station having:

a judging unit for judging one type of handover for which a handover start condition is weakest among available types of handover; and

a checking unit for checking whether the handover start condition for said one type of handover is satisfied or not, and notifying each base station for carrying out said one type of handover when the handover start condition for said one type of handover is satisfied.

12. The system of claim 11, wherein one base station has a notifying unit for notifying to the mobile station in advance a particular type of handover among said multiple types of handover that cannot be carried out at said one base station; and

wherein at a time of handover with respect to said one base station, the judging unit judges said one type of handover from said available types of handover which include said multiple types of handover except for said particular type of handover.

13. The system of claim 11, wherein one base station has a notifying unit for notifying to the mobile station in advance an available frequency bandwidth for each surrounding cell/sector of said one base station;

the mobile station also has a determining unit for determining one cell/sector for which a same code same frequency soft handover cannot be carried out according to the available

frequency bandwidth for said one cell/sector as notified by the notifying unit; and

wherein said multiple types of handover includes a same code same frequency soft handover and a different frequency soft handover, and at a time of handover with respect to said one cell/sector determined by the determining unit, the judging unit judges the different frequency soft handover as said one type of handover so that the checking unit does not check the handover start condition for the same code same frequency soft handover with respect to said one cell/sector.

14. The system of claim 11, wherein one base station has a notifying unit for notifying to the mobile station in advance an information as to whether a soft handover is possible or not with respect to each surrounding cell/sector of said one base station;

the mobile station also has a determining unit for determining one cell/sector for which the soft handover is not possible according to the information for said one cell/sector as notified by the notifying unit; and

wherein said multiple types of handover includes a soft handover and a hard handover, and at a time of handover with respect to said one cell/sector determined by the determining unit, the judging unit judges the hard handover as said one type of handover so that the checking unit does not check the handover start condition for the soft handover with respect to said one cell/sector.

15. The system of claim 11, wherein the mobile station also has:

a measuring unit for measuring a radio channel state; and  
a determining unit for determining each impossible type of handover that cannot be carried out by the mobile station according to the radio channel state measured by the measuring unit; and

wherein the judging unit judges said one type of handover from said available types of handover which include said multiple types of handover except for said each impossible type of handover.

16. The system of claim 11, wherein the mobile station also has:

a measuring unit for measuring an interference receiving level or a total receiving level of a frequency bandwidth currently used for communication; and

wherein said multiple types of handover includes a same code same frequency soft handover and a different frequency soft handover, and when a measured value obtained by the measuring unit is greater than a prescribed threshold value, the judging unit judges the different frequency soft handover as said one type of handover so that the checking unit does not check the handover start condition for the same code same frequency soft handover.

17. The system of claim 11, wherein each base station has:

a measuring unit for measuring a radio channel state for each cell/sector of said each base station;  
a determining unit for determining each impossible type of handover that cannot be carried out for each cell/sector by said each base station according to the radio channel state measured by the measuring unit; and  
a notifying unit for notifying an information indicating said each impossible type of handover to the mobile station; and

wherein at a time of handover with respect to said each base station, the judging unit judges said one type of handover from said available types of handover which include said multiple types of handover except for said each impossible type of handover according to said information.

18. The system of claim 17, wherein the notifying unit notifies said information to surrounding base stations and the mobile station receives said information via one of said surrounding base stations with which the mobile station is currently communicating.

19. The system of claim 11, wherein each base station has:

a measuring unit for measuring an interference receiving level or a total receiving level of each frequency bandwidth that is implemented at said each base station for each cell/sector of said each base station; and  
a notifying unit for notifying an information indicating that one frequency bandwidth cannot be used for one cell/sector to the mobile station, when a measured value for said one frequency bandwidth and said one cell/sector is greater than a prescribed threshold value; and

wherein said multiple types of handover includes a same code same frequency soft handover and a different frequency soft handover, and at a time of handover with respect to

said one cell/sector while the mobile station is currently using said one frequency bandwidth as indicated by said information, the judging unit judges the different frequency soft handover as said one type of handover so that the checking unit does not check the handover start condition for the same code same frequency soft handover with respect to said one cell/sector.

20. The system of claim 19, wherein the notifying unit notifies said information to surrounding base stations and the mobile station receives said information via one of said surrounding base stations with which the mobile station is currently communicating.

21. A mobile station apparatus for use as a mobile station in a CDMA mobile communication system for carrying out any of multiple types of handover with different handover start conditions, the apparatus comprising:

a judging unit for judging one type of handover for which a handover start condition is weakest among available types of handover; and a checking unit for checking whether the handover start condition for said one type of handover is satisfied or not, and notifying each base station for carrying out said one type of handover when the handover start condition for said one type of handover is satisfied.

22. The apparatus of claim 21, wherein at a time of handover with respect to one base station, the judging unit receives in advance a particular type of handover among said multiple types of handover that cannot be carried out at said one base station, and the judging unit judges said one type of handover from said available types of handover which include said multiple types of handover except for said particular type of handover.

23. The apparatus of claim 21, further comprising:

a determining unit for receiving from one base station in advance an available frequency bandwidth for each surrounding cell/sector of said one base station, and determining one cell/sector for which a same code same frequency soft handover cannot be carried out according to the available frequency bandwidth for said one cell/sector as notified from said one base station;

wherein said multiple types of handover includes a same code same frequency soft handover and a different frequency soft handover, and at a time of handover with respect to

said one cell/sector determined by the determining unit, the judging unit judges the different frequency soft handover as said one type of handover so that the checking unit does not check the handover start condition for the same code same frequency soft handover with respect to said one cell/sector.

24. The apparatus of claim 21, further comprising:

a determining unit for receiving from one base station in advance an information as to whether a soft handover is possible or not with respect to each surrounding cell/sector of said one base station, and determining one cell/sector for which the soft handover is not possible according to the information for said one cell/sector as notified from said one base station; and

wherein said multiple types of handover includes a soft handover and a hard handover, and at a time of handover with respect to said one cell/sector determined by the determining unit, the judging unit judges the hard handover as said one type of handover so that the checking unit does not check the handover start condition for the soft handover with respect to said one cell/sector.

25. The apparatus of claim 21, further comprising:

a measuring unit for measuring a radio channel state; and a determining unit for determining each impossible type of handover that cannot be carried out according to the radio channel state measured by the measuring unit; and

wherein the judging unit judges said one type of handover from said available types of handover which include said multiple types of handover except for said each impossible type of handover.

26. The apparatus of claim 21, further comprising:

a measuring unit for measuring an interference receiving level or a total receiving level of a frequency bandwidth currently used for communication; and

wherein said multiple types of handover includes a same code same frequency soft handover and a different frequency soft handover, and when a measured value obtained by the measuring unit is greater than a prescribed threshold value, the judging unit judges the different frequency soft handover as said one type of handover so that the checking unit does not check the handover start condition for the

same code same frequency soft handover.

27. The apparatus of claim 21, wherein each base station measures a radio channel state for each cell/sector of said each base station, determines each impossible type of handover that cannot be carried out for each cell/sector by said each base station according to the radio channel state measured by said each base station, and notifies an information indicating said each impossible type of handover to the mobile station; and  
 wherein at a time of handover with respect to said each base station, the judging unit receives said information and judges said one type of handover from said available types of handover which include said multiple types of handover except for said each impossible type of handover according to said information.
28. The apparatus of claim 27, wherein said each base station notifies said information to surrounding base stations and the judging unit receives said information via one of said surrounding base stations with which the mobile station is currently communicating.
29. The apparatus of claim 21, wherein each base station measures an interference receiving level or a total receiving level of each frequency bandwidth that is implemented at said each base station for each cell/sector of said each base station, and notifies an information indicating that one frequency bandwidth cannot be used for one cell/sector to the mobile station, when a measured value for said one frequency bandwidth and said one cell/sector is greater than a prescribed threshold value; and  
 wherein said multiple types of handover includes a same code same frequency soft handover and a different frequency soft handover, and at a time of handover with respect to said one cell/sector while the mobile station is currently using said one frequency bandwidth as indicated by said information, the judging unit receives said information and judges the different frequency soft handover as said one type of handover so that the checking unit does not check the handover start condition for the same code same frequency soft handover with respect to said one cell/sector.
30. The apparatus of claim 29, wherein said each base station notifies said information to surrounding base stations and the judging unit receives said information via one of said surrounding base stations with which the mobile station is currently communicating.
31. The apparatus of claim 21, further comprising:

a memory for storing the handover start conditions of said multiple types of handover;

wherein the judging unit judges said one type of handover according to the handover start conditions stored in the memory.

32. The apparatus of claim 31, wherein the memory also stores an order of weakness of the handover start conditions among said multiple types of handover.
33. A base station apparatus for use as a base station in a CDMA mobile communication system for carrying out any of multiple types of handover with different handover start conditions, the apparatus comprising:  
 a measuring unit for measuring a radio channel state for each cell/sector of the base station;  
 a determining unit for determining each impossible type of handover that cannot be carried out for each cell/sector by the base station according to the radio channel state measured by the measuring unit; and  
 a notifying unit for notifying an information indicating said each impossible type of handover to a mobile station, so that at a time of handover with respect to the base station, the mobile station judges one type of handover for which a handover start condition is weakest among available types of handover which include said multiple types of handover except for said each impossible type of handover according to said information, checks whether the handover start condition for said one type of handover is satisfied or not, and notifies each base station for carrying out said one type of handover when the handover start condition for said one type of handover is satisfied.
34. The apparatus of claim 33, wherein the notifying unit notifies said information to surrounding base stations and the mobile station receives said information via one of said surrounding base stations with which the mobile station is currently communicating.
35. A base station apparatus for use as a base station in a CDMA mobile communication system for carrying out any of multiple types of handover with different handover start conditions including a same code same frequency soft handover and a different frequency soft handover, the apparatus comprising:  
 a measuring unit for measuring an interference receiving level or a total receiving level of each frequency bandwidth that is implemented at the base station for each cell/sector of the base

station; and

a notifying unit for notifying an information indicating that one frequency bandwidth cannot be used for one cell/sector to a mobile station, when a measured value for said one frequency bandwidth and said one cell/sector is greater than a prescribed threshold value, so that at a time of handover with respect to said one cell/sector while the mobile station is currently using said one frequency bandwidth as indicated by said information, the mobile station judges the different frequency soft handover as having a weakest handover start condition among available types of handover, checks whether the handover start condition for the different frequency soft handover is satisfied or not without checking the handover start condition for the same code same frequency soft handover with respect to said one cell/sector, and notifies each base station for carrying out the different frequency soft handover when the handover start condition for the different frequency soft handover is satisfied.

5  
10  
15  
20  
25  
30

36. The apparatus of claim 35, wherein the notifying unit notifies said information to surrounding base stations and the mobile station receives said information via one of said surrounding base stations with which the mobile station is currently communicating.

25  
30

35

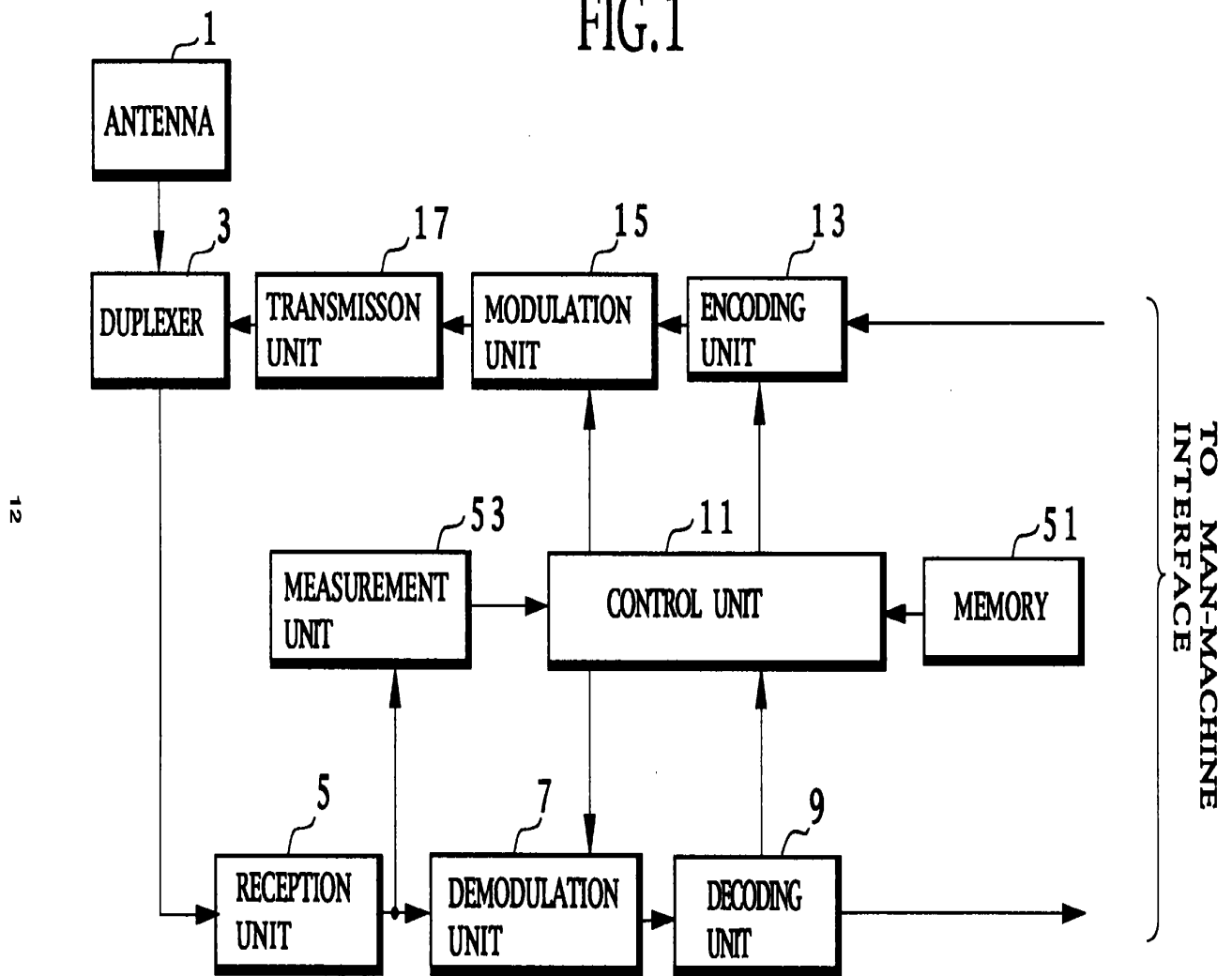
40

45

50

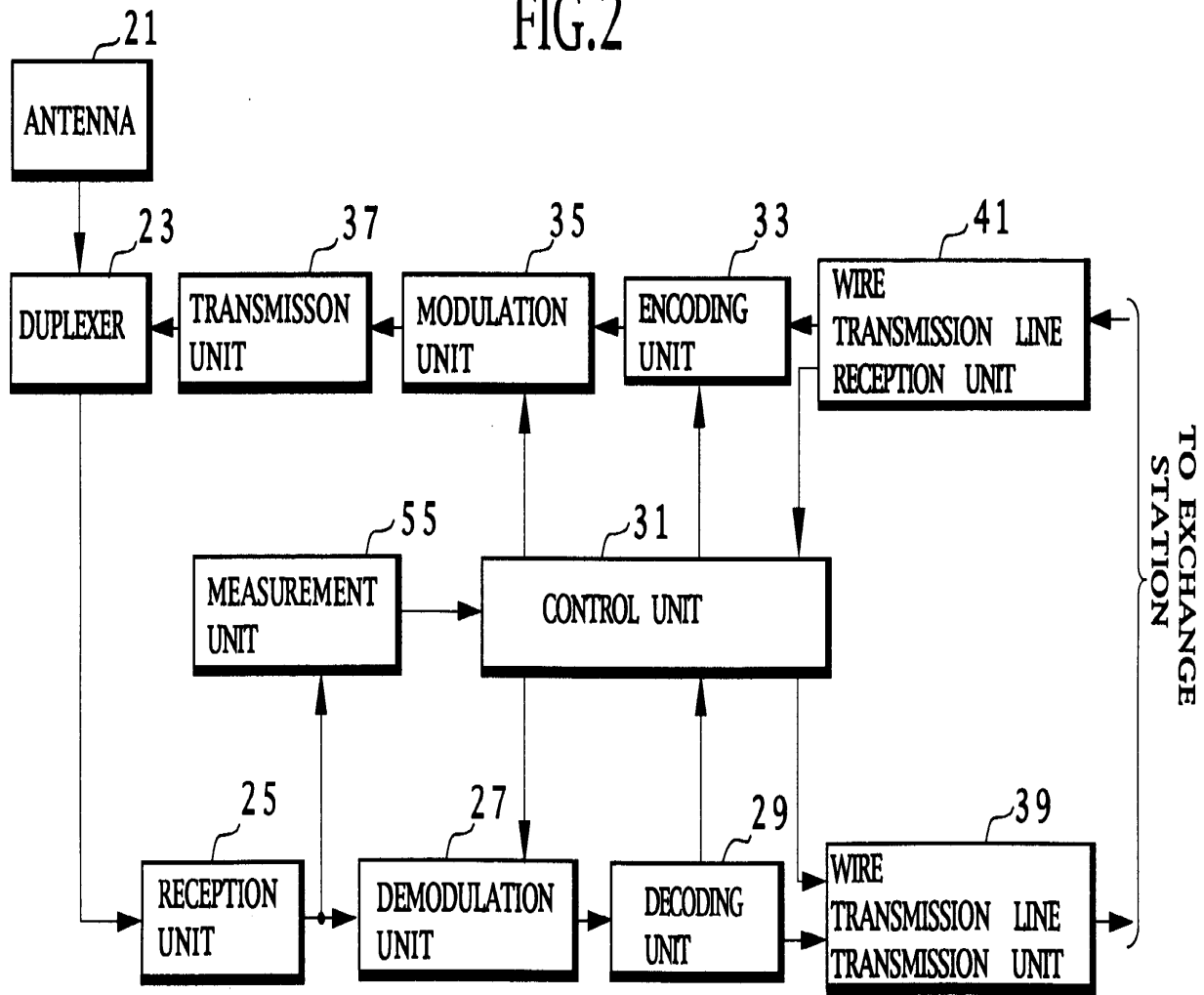
55

FIG.1



EP 0 817 517 A1

FIG.2

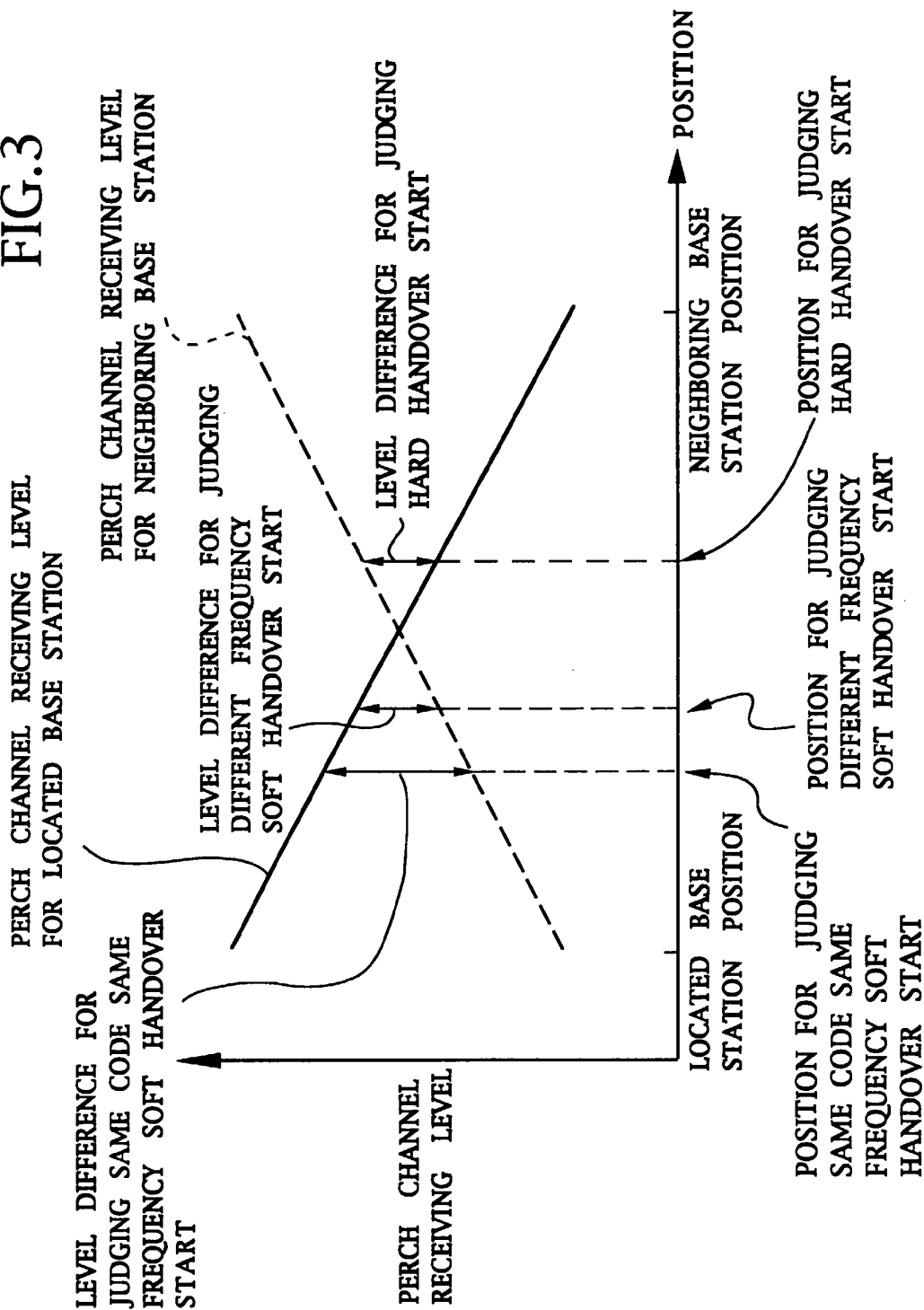


EP 0 817 517 A1

13



FIG.3





European Patent Office

EUROPEAN SEARCH REPORT

Application Number  
EP 97 11 0306

DOCUMENTS CONSIDERED TO BE RELEVANT			
Category	Citation of document with indication, where appropriate, of relevant passages	Relevant to claim	CLASSIFICATION OF THE APPLICATION (Int.Cl.6)
X	US 5 257 402 A (CRISLER KENNETH J) 26 October 1993	1,5,11,15,21,25,33	H04Q7/38 H04B7/26
A	* column 6, line 6 - column 6, line 60; figures 4,5 *	35	
A	WO 95 16329 A (MOTOROLA INC) 15 June 1995	1,4-6,11,14-19,21,24-29,33,35	
A	WO 96 02117 A (NOKIA TELECOMMUNICATIONS OY; JOLMA PETRI (FI)) 25 January 1996	1,4,11,14,21,24,33	
	* page 1, line 21 - page 2, line 36 * * page 4, line 23 - page 4, line 35 * * page 7, line 9 - page 7, line 21 * ----- * page 3, line 17 - page 5, line 14 * -----		TECHNICAL FIELDS SEARCHED (Int.Cl.6)  H04Q H04B
The present search report has been drawn up for all claims			
Place of search <b>MUNICH</b>		Date of completion of the search <b>30 September 1997</b>	Examiner <b>Burghardt, G</b>
CATEGORY OF CITED DOCUMENTS X : particularly relevant if taken alone Y : particularly relevant if combined with another document of the same category A : technological background O : non-written disclosure P : intermediate document		T : theory or principle underlying the invention E : earlier patent document, but published on, or after the filing date D : document cited in the application L : document cited for other reasons & : member of the same patent family, corresponding document	

EPC FORM 1503 03.82 (P04C01)

## Electronic Patent Application Fee Transmittal

<b>Application Number:</b>	15495539			
<b>Filing Date:</b>	24-Apr-2017			
<b>Title of Invention:</b>	DIRECTED WIRELESS COMMUNICATION			
<b>First Named Inventor/Applicant Name:</b>	Marcus Da Silva			
<b>Filer:</b>	Glen L. Nuttall/Mariel Boyan			
<b>Attorney Docket Number:</b>	XRCOM.001C5			
Filed as Small Entity				
<b>Filing Fees for Utility under 35 USC 111(a)</b>				
<b>Description</b>	<b>Fee Code</b>	<b>Quantity</b>	<b>Amount</b>	<b>Sub-Total in USD(\$)</b>
<b>Basic Filing:</b>				
<b>Pages:</b>				
<b>Claims:</b>				
<b>Miscellaneous-Filing:</b>				
<b>Petition:</b>				
<b>Patent-Appeals-and-Interference:</b>				
<b>Post-Allowance-and-Post-Issuance:</b>				
<b>Extension-of-Time:</b>				

Description	Fee Code	Quantity	Amount	Sub-Total in USD(\$)
<b>Miscellaneous:</b>				
SUBMISSION- INFORMATION DISCLOSURE STMT	2806	1	90	90
<b>Total in USD (\$)</b>				<b>90</b>

## Electronic Acknowledgement Receipt

<b>EFS ID:</b>	31103996
<b>Application Number:</b>	15495539
<b>International Application Number:</b>	
<b>Confirmation Number:</b>	1050
<b>Title of Invention:</b>	DIRECTED WIRELESS COMMUNICATION
<b>First Named Inventor/Applicant Name:</b>	Marcus Da Silva
<b>Customer Number:</b>	20995
<b>Filer:</b>	Glen L. Nuttall/Mariel Boyan
<b>Filer Authorized By:</b>	Glen L. Nuttall
<b>Attorney Docket Number:</b>	XRCOM.001C5
<b>Receipt Date:</b>	01-DEC-2017
<b>Filing Date:</b>	24-APR-2017
<b>Time Stamp:</b>	14:18:57
<b>Application Type:</b>	Utility under 35 USC 111(a)

### Payment information:

Submitted with Payment	yes
Payment Type	CARD
Payment was successfully received in RAM	\$90
RAM confirmation Number	120417INTEFSW14203400
Deposit Account	111159
Authorized User	Mariel Boyan

The Director of the USPTO is hereby authorized to charge indicated fees and credit any overpayment as follows:  
37 CFR 1.21 (Miscellaneous fees and charges)

<b>File Listing:</b>					
<b>Document Number</b>	<b>Document Description</b>	<b>File Name</b>	<b>File Size(Bytes)/ Message Digest</b>	<b>Multi Part /.zip</b>	<b>Pages (if appl.)</b>
1		1640-001-203-- IDSAsFiled12012017.pdf	1178628  bfe58152a3cc1983096b77997cdc77fb6800 f7f8	yes	11
<b>Multipart Description/PDF files in .zip description</b>					
<b>Document Description</b>			<b>Start</b>	<b>End</b>	
Information Disclosure Statement (IDS) Form (SB08)			4	11	
Transmittal Letter			1	3	
<b>Warnings:</b>					
The page size in the PDF is too large. The pages should be 8.5 x 11 or A4. If this PDF is submitted, the pages will be resized upon entry into the Image File Wrapper and may affect subsequent processing					
<b>Information:</b>					
2	Foreign Reference	WO0038455A1-00001819.pdf	1131897  73ab0aa9cac0c0926a79622b8377c5b2ec4 eccc02	no	33
<b>Warnings:</b>					
<b>Information:</b>					
3	Foreign Reference	WO0072464A1-00001852.pdf	1512506  73faeb8c8f925abc20ff7915ec29518bc1b7 a7b	no	41
<b>Warnings:</b>					
<b>Information:</b>					
4	Foreign Reference	WO0110156A1-00001893.pdf	4707279  5f389ea32493c04e4150c14526944a27ab0 7862f	no	114
<b>Warnings:</b>					
<b>Information:</b>					
5	Foreign Reference	WO0110156A1-00002007.pdf	5322311  de03aaadf9a1145753f7a48771fe061e784b 0ab7	no	115

<b>Warnings:</b>					
<b>Information:</b>					
6	Foreign Reference	WO0375396A2-00002122.pdf	2292591	no	53
			ae118270b27de61573de39bc704f0e7019f dbedd		
<b>Warnings:</b>					
<b>Information:</b>					
7	Foreign Reference	WO9621117A1-00003631.pdf	824900	no	26
			ae8c64787263b03c0c6e4fc5efe603bd2ab8 5d6c		
<b>Warnings:</b>					
<b>Information:</b>					
8	Foreign Reference	WO9700543A1-00002175.pdf	2746666	no	62
			94713f398fc270e7fda81784c02f2949f474b e97		
<b>Warnings:</b>					
<b>Information:</b>					
9	Foreign Reference	WO9733388A1-00002237.pdf	2398811	no	53
			7b8680d454139f189363ea58f8e0804dd8f6 edc6		
<b>Warnings:</b>					
<b>Information:</b>					
10	Foreign Reference	WO9809381A1-00002290.pdf	1210808	no	33
			00db99c49abefb4d1bb050c2d109a08dfadb 5753a		
<b>Warnings:</b>					
<b>Information:</b>					
11	Foreign Reference	WO9818271A3-00002323.pdf	1638138	no	42
			a6518e5ac8f60987698b070a1503cf09019a fc03		
<b>Warnings:</b>					
<b>Information:</b>					
12	Foreign Reference	WO9921391A2-00002365.pdf	561426	no	15
			8d651f36f1d18e929a086dc7165f757cd866 b293		
<b>Warnings:</b>					
<b>Information:</b>					

13	Foreign Reference	EP0817517A1-00002493.pdf	909148	no	15
			b7fe68acb3f573055bd13b6c59761170f0d583d0		
<b>Warnings:</b>					
<b>Information:</b>					
14	Non Patent Literature	DEFS-VIVATO-00000001.pdf	9435230	no	96
			196f8103b3ae3397ab5b56c641b1758dfa3000c8		
<b>Warnings:</b>					
<b>Information:</b>					
15	Non Patent Literature	DEFS-VIVATO-00000097.pdf	901937	no	5
			ceddf5c61a78efa4b3ca153d8ecd40175e207796		
<b>Warnings:</b>					
<b>Information:</b>					
16	Non Patent Literature	DEFS-VIVATO-00000102.pdf	1575050	no	7
			86eb1744a93f40e818ca7ef8de463b54779562a5		
<b>Warnings:</b>					
<b>Information:</b>					
17	Non Patent Literature	DEFS-VIVATO-00000109.pdf	928782	no	6
			d2ff2d54a5435d53a56bb7df5fa82fb623c4ad1		
<b>Warnings:</b>					
<b>Information:</b>					
18	Non Patent Literature	DEFS-VIVATO-00000121.pdf	1793021	no	9
			ef61efe28c172b66b30a91d9b9c5644dee64ded		
<b>Warnings:</b>					
<b>Information:</b>					
19	Non Patent Literature	DEFS-VIVATO-00000130.pdf	354654	no	3
			78053bd4d9ca93c7a8555283f1c40125527691e48		
<b>Warnings:</b>					
<b>Information:</b>					



20	Non Patent Literature	DEFS-VIVATO-00000133.pdf	3819691	no	34
			8658cf0441ec090a312dbc8f83de2c647a4b bde8		
<b>Warnings:</b>					
<b>Information:</b>					
21	Non Patent Literature	DEFS-VIVATO-00000167.pdf	601681	no	4
			a07dbd4c6f951e2dc559db31e1b6a06a657 74318		
<b>Warnings:</b>					
<b>Information:</b>					
22	Non Patent Literature	DEFS-VIVATO-00000171.pdf	1021005	no	5
			29f51919216c0525de2111b74b4e3df6146 8c70a		
<b>Warnings:</b>					
<b>Information:</b>					
23	Non Patent Literature	DEFS-VIVATO-00000176.pdf	741977	no	3
			2be006e48ce7cfc0c4878f0e158d69c8d20f6 2102		
<b>Warnings:</b>					
<b>Information:</b>					
24	Non Patent Literature	DEFS-VIVATO-00000179.pdf	861085	no	4
			3fdaf8bab94f1a2cdfae59146bb9738e2262 9dc4		
<b>Warnings:</b>					
<b>Information:</b>					
25	Non Patent Literature	DEFS-VIVATO-00000183.pdf	1096592	no	5
			a099978bf2de91fa8b03e6cd4334141b621 3863c		
<b>Warnings:</b>					
<b>Information:</b>					
26	Non Patent Literature	DEFS-VIVATO-00000188.pdf	1840646	no	9
			8b2c299cea45d0af103dd33762a62394963 d6f32		
<b>Warnings:</b>					
<b>Information:</b>					

27	Non Patent Literature	DEFS-VIVATO-00000197.pdf	1086290	no	5
			f7f9ead0a33b9e77455f99b10dc96d8f5c978215		
<b>Warnings:</b>					
<b>Information:</b>					
28	Non Patent Literature	DEFS-VIVATO-00000202.pdf	2021280	no	10
			e0b9a74b2f8a54073b821ee42b0ce2eb236db163		
<b>Warnings:</b>					
<b>Information:</b>					
29	Non Patent Literature	DEFS-VIVATO-00000212.pdf	4114836	no	20
			ed7c29596293d36c1ecd6e0f366c09806a1e9fe		
<b>Warnings:</b>					
<b>Information:</b>					
30	Non Patent Literature	DEFS-VIVATO-00000232.pdf	2877924	no	19
			e9809d1643dc5a1c51b7661775b18109c37bf9		
<b>Warnings:</b>					
<b>Information:</b>					
31	Non Patent Literature	DEFS-VIVATO-00000251.pdf	9457378	no	91
			6d66df911131f8e7db2433970ae1533bec583d54		
<b>Warnings:</b>					
<b>Information:</b>					
32	Non Patent Literature	DEFS-VIVATO-00000342.pdf	683506	no	4
			88c4bd9e48bfd0d83c1e66f357ab4bed442613e		
<b>Warnings:</b>					
<b>Information:</b>					
33	Non Patent Literature	DEFS-VIVATO-00000346.pdf	1540628	no	7
			9bb4de42ba7187ed300768b8b0960ef4f00b0760		
<b>Warnings:</b>					
<b>Information:</b>					

34	Non Patent Literature	DEFS-VIVATO-00000353.pdf	880747	no	5
			305f760d9202d2b1d3326803b2fc1f93dc126b11		
<b>Warnings:</b>					
<b>Information:</b>					
35	Non Patent Literature	DEFS-VIVATO-00000358.pdf	625178	no	3
			cf68d995bf3e207bc5cfba8003af39a851f68790		
<b>Warnings:</b>					
<b>Information:</b>					
36	Non Patent Literature	DEFS-VIVATO-00000361.pdf	1469870	no	8
			869bd815611669d2b2cd2ad33ef74d8e7da2d264		
<b>Warnings:</b>					
<b>Information:</b>					
37	Non Patent Literature	DEFS-VIVATO-00000369.pdf	1425742	no	11
			50f2dabd0b1d49a2c861281cae018ab3db22dfa1		
<b>Warnings:</b>					
<b>Information:</b>					
38	Non Patent Literature	DEFS-VIVATO-00000380.pdf	1913741	no	10
			fcdd601d0e4da9f19d2ef004dccc8a07bf894a579		
<b>Warnings:</b>					
<b>Information:</b>					
39	Non Patent Literature	DEFS-VIVATO-00000390.pdf	873076	no	5
			fa944849cbd8a8260c02bbd678b0c48b757e74b7		
<b>Warnings:</b>					
<b>Information:</b>					
40	Non Patent Literature	DEFS-VIVATO-00000395.pdf	820626	no	5
			b13a90a7b17eac7ffc5d778695a5da59c6e4da0b		
<b>Warnings:</b>					
<b>Information:</b>					

41	Non Patent Literature	DEFS-VIVATO-00000400.pdf	2041807	no	10
			3d11a19ea5ee9f21d874c20a46957314cbc43b20		
<b>Warnings:</b>					
<b>Information:</b>					
42	Non Patent Literature	DEFS-VIVATO-00000410.pdf	787023	no	4
			6ed433ddb8f1274fc83d94034ef3397c5ce0440f		
<b>Warnings:</b>					
<b>Information:</b>					
43	Non Patent Literature	DEFS-VIVATO-00000414.pdf	1461568	no	12
			19946ea33897a2170ba4752c9bc361d5e50691f6		
<b>Warnings:</b>					
<b>Information:</b>					
44	Non Patent Literature	DEFS-VIVATO-00000426.pdf	1278505	no	10
			2dd2364626c24b94cc28130719b2a07e90b5a7d5		
<b>Warnings:</b>					
<b>Information:</b>					
45	Non Patent Literature	DEFS-VIVATO-00000436.pdf	597927	no	4
			4cf2aa701bcb0e939d3588cc78fca3cd55a4f1bd		
<b>Warnings:</b>					
<b>Information:</b>					
46	Non Patent Literature	DEFS-VIVATO-00000440.pdf	8567947	no	35
			02daeb1934e140ecee80a2408f09252d404407a4		
<b>Warnings:</b>					
<b>Information:</b>					
47	Non Patent Literature	DEFS-VIVATO-00000484.pdf	2989849	no	12
			2c995d0beaa3514d80054d2c640a087c7a1f0417		
<b>Warnings:</b>					
<b>Information:</b>					

48	Non Patent Literature	DEFS-VIVATO-00000496.pdf	911295	no	5
			9628f072629973d37b3b8e9c9d7172d14e189f412		
<b>Warnings:</b>					
<b>Information:</b>					
49	Non Patent Literature	DEFS-VIVATO-00000501.pdf	923458	no	5
			5fd46da93e6ef9b15293eae79bed2028c771c		
<b>Warnings:</b>					
<b>Information:</b>					
50	Non Patent Literature	DEFS-VIVATO-00000767.pdf	1370823	no	8
			57895aa562f6520370f9b71d1c0a93514c506152		
<b>Warnings:</b>					
<b>Information:</b>					
51	Non Patent Literature	DEFS-VIVATO-00000775.pdf	1515404	no	8
			8525753d7e19ff5f849af6932896237f3665eaf4		
<b>Warnings:</b>					
<b>Information:</b>					
52	Non Patent Literature	DEFS-VIVATO-00000783.pdf	547906	no	5
			ea3c14834ac6e88293b25f03a12336a76b89ec25		
<b>Warnings:</b>					
<b>Information:</b>					
53	Non Patent Literature	DEFS-VIVATO-00000788.pdf	228575	no	3
			9588ec14be9058562b4b9543cca1b8ac7e84c64e		
<b>Warnings:</b>					
<b>Information:</b>					
54	Non Patent Literature	DEFS-VIVATO-00000791.pdf	520374	no	5
			65fcb9f99c82a23e87838befdfac25179600af16e		
<b>Warnings:</b>					
<b>Information:</b>					

55	Non Patent Literature	DEFS-VIVATO-00000796.pdf	348086	no	3
			0e5302efec1f4b331fee3cc94ace5dc960228e1f		
<b>Warnings:</b>					
<b>Information:</b>					
56	Non Patent Literature	DEFS-VIVATO-00000799.pdf	212508	no	2
			c37779e9f8ad965f484d6717271c159f68c6eb57		
<b>Warnings:</b>					
<b>Information:</b>					
57	Non Patent Literature	DEFS-VIVATO-00000801.pdf	136824	no	1
			748b909da5f279c62a0b7bedc4d06e0454669110		
<b>Warnings:</b>					
<b>Information:</b>					
58	Non Patent Literature	DEFS-VIVATO-00000802.pdf	84826	no	1
			28bf558800057c695395902910aeb2bdc67b125e		
<b>Warnings:</b>					
<b>Information:</b>					
59	Non Patent Literature	DEFS-VIVATO-00000803.pdf	229783	no	3
			c04a64676f70c9e8ed7ce52d92df196a9b7b6c10		
<b>Warnings:</b>					
<b>Information:</b>					
60	Fee Worksheet (SB06)	fee-info.pdf	30489	no	2
			535bbf67689b4e32415cdfd8bcfd1f1e9dbee209f		
<b>Warnings:</b>					
<b>Information:</b>					
<b>Total Files Size (in bytes):</b>			105982259		

**This Acknowledgement Receipt evidences receipt on the noted date by the USPTO of the indicated documents, characterized by the applicant, and including page counts, where applicable. It serves as evidence of receipt similar to a Post Card, as described in MPEP 503.**

**New Applications Under 35 U.S.C. 111**

**If a new application is being filed and the application includes the necessary components for a filing date (see 37 CFR 1.53(b)-(d) and MPEP 506), a Filing Receipt (37 CFR 1.54) will be issued in due course and the date shown on this Acknowledgement Receipt will establish the filing date of the application.**

**National Stage of an International Application under 35 U.S.C. 371**

**If a timely submission to enter the national stage of an international application is compliant with the conditions of 35 U.S.C. 371 and other applicable requirements a Form PCT/DO/EO/903 indicating acceptance of the application as a national stage submission under 35 U.S.C. 371 will be issued in addition to the Filing Receipt, in due course.**

**New International Application Filed with the USPTO as a Receiving Office**

**If a new international application is being filed and the international application includes the necessary components for an international filing date (see PCT Article 11 and MPEP 1810), a Notification of the International Application Number and of the International Filing Date (Form PCT/RO/105) will be issued in due course, subject to prescriptions concerning national security, and the date shown on this Acknowledgement Receipt will establish the international filing date of the application.**

## Electronic Acknowledgement Receipt

<b>EFS ID:</b>	31104974
<b>Application Number:</b>	15495539
<b>International Application Number:</b>	
<b>Confirmation Number:</b>	1050
<b>Title of Invention:</b>	DIRECTED WIRELESS COMMUNICATION
<b>First Named Inventor/Applicant Name:</b>	Marcus Da Silva
<b>Customer Number:</b>	20995
<b>Filer:</b>	Glen L. Nuttall/Mariel Boyan
<b>Filer Authorized By:</b>	Glen L. Nuttall
<b>Attorney Docket Number:</b>	XRCOM.001C5
<b>Receipt Date:</b>	01-DEC-2017
<b>Filing Date:</b>	24-APR-2017
<b>Time Stamp:</b>	16:32:07
<b>Application Type:</b>	Utility under 35 USC 111(a)

### Payment information:

Submitted with Payment	no
------------------------	----

### File Listing:

Document Number	Document Description	File Name	File Size(Bytes)/ Message Digest	Multi Part /.zip	Pages (if appl.)
1	Non Patent Literature	DEFS-VIVATO-00000811.pdf	229324 <small>d7db5c5770eb24f60801032aa02cd91d05a a817e</small>	no	2

### Warnings:



<b>Information:</b>					
2	Non Patent Literature	DEFS-VIVATO-00000813.pdf	435551	no	4
			a9505106d5cf283fc2952490e3422d880dd3e8f		
<b>Warnings:</b>					
<b>Information:</b>					
3	Non Patent Literature	DEFS-VIVATO-00000817.pdf	87859	no	1
			6f2a9b02ba0529a88fbd199c9b54ae15878b15f4		
<b>Warnings:</b>					
<b>Information:</b>					
4	Non Patent Literature	DEFS-VIVATO-00000818.pdf	188729	no	2
			6a639972e9839826164ecf0a423a3fe2e91fe355		
<b>Warnings:</b>					
<b>Information:</b>					
5	Non Patent Literature	DEFS-VIVATO-00000820.pdf	101499	no	1
			7aaf3cf85ed87948946fcc6e7cbaed05c3689cc5		
<b>Warnings:</b>					
<b>Information:</b>					
6	Non Patent Literature	DEFS-VIVATO-00000825.pdf	155153	no	2
			1dd697edfd92e14067ee3855a747ad61d911d6		
<b>Warnings:</b>					
<b>Information:</b>					
7	Non Patent Literature	DEFS-VIVATO-00000827.pdf	205613	no	2
			c0c932bb90cae52f52d9b1db19660879cd830880		
<b>Warnings:</b>					
<b>Information:</b>					
8	Non Patent Literature	DEFS-VIVATO-00000829.pdf	241337	no	2
			7eaa05715902c54feb3cefa3de1c46f9b958635f		
<b>Warnings:</b>					
<b>Information:</b>					

9	Non Patent Literature	DEFS-VIVATO-00000831.pdf	355492	no	3
			39e7743be7a44a144d84d877b5452eb2b701c854		
<b>Warnings:</b>					
<b>Information:</b>					
10	Non Patent Literature	DEFS-VIVATO-00000834.pdf	229867	no	2
			a541bf1b12e0ce32186b7e4525f1ef61a18628e4		
<b>Warnings:</b>					
<b>Information:</b>					
11	Non Patent Literature	DEFS-VIVATO-00000836.pdf	368144	no	3
			c490abb891cdc8437d0bd2b232e3260d4dc3798f		
<b>Warnings:</b>					
<b>Information:</b>					
12	Non Patent Literature	DEFS-VIVATO-00000839.pdf	1439888	no	6
			739fc5d12cce790429b30742ab30d568d399a096		
<b>Warnings:</b>					
<b>Information:</b>					
13	Non Patent Literature	DEFS-VIVATO-00000845.pdf	5587026	no	108
			0f00fe723df1ba4ea1976323165649e31fe63fb1		
<b>Warnings:</b>					
<b>Information:</b>					
14	Non Patent Literature	DEFS-VIVATO-00000953.pdf	568102	no	3
			e69a55b2c83fce2c7e9736366d6a4ab4817db8d6		
<b>Warnings:</b>					
<b>Information:</b>					
15	Non Patent Literature	DEFS-VIVATO-00000956.pdf	4806084	no	12
			6eb65cc829a3ba0701242d7ca339673f46d787c6		
<b>Warnings:</b>					
<b>Information:</b>					

16	Non Patent Literature	DEFS-VIVATO-00000968.pdf	2706155	no	15
			41e1b5a32412a298d7eccca1309c3f3a5bf646532		
<b>Warnings:</b>					
<b>Information:</b>					
17	Non Patent Literature	DEFS-VIVATO-00000983.pdf	780900	no	5
			aa950b0881580fd4ed20148a7ba2f5f20c5d6c3d		
<b>Warnings:</b>					
<b>Information:</b>					
18	Non Patent Literature	DEFS-VIVATO-00000993.pdf	561883	no	3
			8bf7475271405f81c59fb03b8aaadca25fa26f3		
<b>Warnings:</b>					
<b>Information:</b>					
19	Non Patent Literature	DEFS-VIVATO-00000996.pdf	1763340	no	10
			d9578071b09ab3a9490466a2cd6f555379b2ed43		
<b>Warnings:</b>					
<b>Information:</b>					
20	Non Patent Literature	DEFS-VIVATO-00001006.pdf	3166597	no	23
			f739d8de16d7d92b9b1db173de08474a35a594b0		
<b>Warnings:</b>					
<b>Information:</b>					
21	Non Patent Literature	DEFS-VIVATO-00002380.pdf	1936831	no	9
			fc1f5b9382f661c6222b12c59f9d5b31b1d3b755		
<b>Warnings:</b>					
<b>Information:</b>					
22	Non Patent Literature	DEFS-VIVATO-00002389.pdf	1675260	no	6
			7056481a93890c324335462e0397dc08ea596a12		
<b>Warnings:</b>					
<b>Information:</b>					

23	Non Patent Literature	DEFS-VIVATO-00002395.pdf	2282059	no	10
			9d6b26940069b2b3e36fc48dae83df18f d267		
<b>Warnings:</b>					
<b>Information:</b>					
24	Non Patent Literature	DEFS-VIVATO-00002405.pdf	2303068	no	10
			5bdcf3a6b1d3c459398e16b944fadaca2ca7 43ec		
<b>Warnings:</b>					
<b>Information:</b>					
25	Non Patent Literature	DEFS-VIVATO-00002550.pdf	3917994	no	25
			4abf014ad73006c9be00b7152a0b4899491 5b0fc		
<b>Warnings:</b>					
<b>Information:</b>					
26	Non Patent Literature	DEFS-VIVATO-00002701.pdf	672269	no	4
			2a09579121dc95f38d6ef9ecfd4a47195a5c 4aa1		
<b>Warnings:</b>					
<b>Information:</b>					
27	Non Patent Literature	DEFS-VIVATO-00002710.pdf	9467192	no	91
			038e039ad8743e01a6b3121424d6dd9ff7 c3cba		
<b>Warnings:</b>					
<b>Information:</b>					
28	Non Patent Literature	DEFS-VIVATO-00002801.pdf	9458022	no	96
			db0c9123b57c99ce47190205f2263e2e942 e1689		
<b>Warnings:</b>					
<b>Information:</b>					
29	Non Patent Literature	DEFS-VIVATO-00002941.pdf	1625845	no	8
			ea97ef1886140325ba6259339aafc2adad1e 8bb7		
<b>Warnings:</b>					
<b>Information:</b>					

30	Non Patent Literature	DEFS-VIVATO-00003065.pdf	2859935	no	14
			108770fa95a11498695c5f2852e09f3673e2524e		
<b>Warnings:</b>					
<b>Information:</b>					
31	Non Patent Literature	DEFS-VIVATO-00003079.pdf	4252467	no	29
			811104c7349445f41aef6b769f133a06f6b44e5f		
<b>Warnings:</b>					
<b>Information:</b>					
32	Non Patent Literature	DEFS-VIVATO-00003117.pdf	2949940	no	12
			52feb86316347211a717c1352da7b8e677d8a7cf		
<b>Warnings:</b>					
<b>Information:</b>					
33	Non Patent Literature	DEFS-VIVATO-00003593.pdf	1120941	no	6
			80524a32404f690df556e6575ae9ba84767537f0		
<b>Warnings:</b>					
<b>Information:</b>					
34	Non Patent Literature	DEFS-VIVATO-00003607.pdf	2928421	no	12
			c80d6cee2a7d8f0b093e692bc94c5909775cd15		
<b>Warnings:</b>					
<b>Information:</b>					
35	Non Patent Literature	DEFS-VIVATO-00003661.pdf	505272	no	3
			145a43eaa99b1155468b35cad48c59d1958df02a		
<b>Warnings:</b>					
<b>Information:</b>					
36	Non Patent Literature	DEFS-VIVATO-00003675.pdf	979690	no	6
			99fc83b873264d34f2b334d0c74500ebbaa12e09		
<b>Warnings:</b>					
<b>Information:</b>					

37	Non Patent Literature	DEFS-VIVATO-00003842.pdf	275045	no	12
			e946375a6aedb7eeb9a413f90e4b88c8f8d2b58b		
<b>Warnings:</b>					
<b>Information:</b>					
38	Non Patent Literature	DEFS-VIVATO-00003854.pdf	287619	no	16
			031b11586a09fed5cd531c4b53c6106b6983fda5		
<b>Warnings:</b>					
<b>Information:</b>					
39	Non Patent Literature	DEFS-VIVATO-00003870.pdf	1179873	no	5
			45618c625388ad94a44c20730c974b9cb01852dc		
<b>Warnings:</b>					
<b>Information:</b>					
40	Non Patent Literature	InvalidityContentions-pdf.pdf	601272	no	85
			4bbdeae9f3dc3379f99291fce25631c463ff611e		
<b>Warnings:</b>					
<b>Information:</b>					
41	Non Patent Literature	ExA1-US5471647.pdf	8493429	no	14
			cbfc3bfbbebd32b4f415eae14e753ee7d3ad7c8		
<b>Warnings:</b>					
<b>Information:</b>					
42	Non Patent Literature	ExA2-US5515378-1of2.pdf	15679875	no	30
			33408ce86e8a34c8acd4d6d2f359b647fb85665e		
<b>Warnings:</b>					
<b>Information:</b>					
43	Non Patent Literature	ExA2-US5515378-2of2.pdf	18402524	no	35
			f0d0ea76f645e90370f292186c6a3db2567f43f9		
<b>Warnings:</b>					
<b>Information:</b>					

44	Non Patent Literature	ExA3-US5634199.pdf	24068280	no	42
			d26a29517a2d7a5f092853066cbc266dff3620c2		
<b>Warnings:</b>					
<b>Information:</b>					
45	Non Patent Literature	ExA4-US5739788.pdf	24512019	no	43
			8e6239ccc85021a9db8023c1768c81cfaee4a2c8		
<b>Warnings:</b>					
<b>Information:</b>					
46	Non Patent Literature	ExA5-US5890067-1of2.pdf	11857076	no	20
			c2b3ad6c7b3165f00ef1b39817592e89e0ab68ce		
<b>Warnings:</b>					
<b>Information:</b>					
47	Non Patent Literature	ExA5-US5890067-2of2.pdf	16070694	no	26
			d72b7959a4876b99f256f19a5fce91ef104ee3a7		
<b>Warnings:</b>					
<b>Information:</b>					
48	Non Patent Literature	ExA6-US6006110.pdf	10565893	no	17
			44e18327241461733fd329687fde97405dcf779d		
<b>Warnings:</b>					
<b>Information:</b>					
49	Non Patent Literature	ExA7-US6067290-1of2.pdf	24334942	no	35
			4b2943690ba3112b6007d78d4666d8522159a1d5		
<b>Warnings:</b>					
<b>Information:</b>					
50	Non Patent Literature	ExA7-US6067290-2of2.pdf	22460367	no	36
			dd76c11f183f6fc6f1ddac375e5217846dae847c		
<b>Warnings:</b>					
<b>Information:</b>					

51	Non Patent Literature	ExA8-US6101399-1of2.pdf	13590982	no	30
			f7eeb1eb3ee7290b1162779af982d515ddbb30512		
<b>Warnings:</b>					
<b>Information:</b>					
52	Non Patent Literature	ExA8-US6101399-2of2.pdf	14950592	no	24
			785326c983940cb4e461ca5400580e0b9613ba47		
<b>Warnings:</b>					
<b>Information:</b>					
53	Non Patent Literature	ExA9-US6219561.pdf	2618815	no	92
			f15b19b4bca2c946ae28c0760ba4e88a4d66372		
<b>Warnings:</b>					
<b>Information:</b>					
54	Non Patent Literature	ExA10-US6330460.pdf	1739826	no	51
			ddf0bb19dead291ac82c31682159006f69100d4f		
<b>Warnings:</b>					
<b>Information:</b>					
55	Non Patent Literature	ExA11-US6351499.pdf	2252751	no	91
			fe5be141d5a06b682a30d5a058df837f0f126ce1		
<b>Warnings:</b>					
<b>Information:</b>					
56	Non Patent Literature	ExA12-US6564036.pdf	1166825	no	45
			17e81dc1d7b904f761e5cea0839aa5e1ebd1128		
<b>Warnings:</b>					
<b>Information:</b>					
57	Non Patent Literature	ExA13-US6795409.pdf	2888544	no	94
			3537d9b4034143869cf02ff3b044e19e16dae795		
<b>Warnings:</b>					
<b>Information:</b>					



58	Non Patent Literature	ExA14-Raleigh545.pdf	4143379	no	149
			9ddf98a98bc0be58cad34452df4caa15b2d05e4		
<b>Warnings:</b>					
<b>Information:</b>					
59	Non Patent Literature	ExA15-WO0072464A1.pdf	550776	no	17
			e57dd181d4169d54b090db3e128bc44a98beabd0		
<b>Warnings:</b>					
<b>Information:</b>					
60	Non Patent Literature	ExA16-231_InvalidityChart-Paulraj156.pdf	3049053	no	89
			67ee5e7024e31216db2e57ceba53b20d756cc466		
<b>Warnings:</b>					
<b>Information:</b>					
<b>Total Files Size (in bytes):</b>					298654200
<p><b>This Acknowledgement Receipt evidences receipt on the noted date by the USPTO of the indicated documents, characterized by the applicant, and including page counts, where applicable. It serves as evidence of receipt similar to a Post Card, as described in MPEP 503.</b></p> <p><b><u>New Applications Under 35 U.S.C. 111</u></b>  <b>If a new application is being filed and the application includes the necessary components for a filing date (see 37 CFR 1.53(b)-(d) and MPEP 506), a Filing Receipt (37 CFR 1.54) will be issued in due course and the date shown on this Acknowledgement Receipt will establish the filing date of the application.</b></p> <p><b><u>National Stage of an International Application under 35 U.S.C. 371</u></b>  <b>If a timely submission to enter the national stage of an international application is compliant with the conditions of 35 U.S.C. 371 and other applicable requirements a Form PCT/DO/EO/903 indicating acceptance of the application as a national stage submission under 35 U.S.C. 371 will be issued in addition to the Filing Receipt, in due course.</b></p> <p><b><u>New International Application Filed with the USPTO as a Receiving Office</u></b>  <b>If a new international application is being filed and the international application includes the necessary components for an international filing date (see PCT Article 11 and MPEP 1810), a Notification of the International Application Number and of the International Filing Date (Form PCT/RO/105) will be issued in due course, subject to prescriptions concerning national security, and the date shown on this Acknowledgement Receipt will establish the international filing date of the application.</b></p>					

## Electronic Acknowledgement Receipt

<b>EFS ID:</b>	31107953
<b>Application Number:</b>	15495539
<b>International Application Number:</b>	
<b>Confirmation Number:</b>	1050
<b>Title of Invention:</b>	DIRECTED WIRELESS COMMUNICATION
<b>First Named Inventor/Applicant Name:</b>	Marcus Da Silva
<b>Customer Number:</b>	20995
<b>Filer:</b>	Glen L. Nuttall/Mariel Boyan
<b>Filer Authorized By:</b>	Glen L. Nuttall
<b>Attorney Docket Number:</b>	XRCOM.001C5
<b>Receipt Date:</b>	01-DEC-2017
<b>Filing Date:</b>	24-APR-2017
<b>Time Stamp:</b>	16:58:44
<b>Application Type:</b>	Utility under 35 USC 111(a)

### Payment information:

Submitted with Payment	no
------------------------	----

### File Listing:

Document Number	Document Description	File Name	File Size(Bytes)/ Message Digest	Multi Part /.zip	Pages (if appl.)
1	Non Patent Literature	ExA17-Raleigh543.pdf	3669388 <small>771f95dd7e5c570bb57f472efc343c11a4c24ac2</small>	no	104

### Warnings:

<b>Information:</b>					
2	Non Patent Literature	ExA18-231Chart-Raleigh388PCTPub.pdf	5367160	no	172
			06d7049c33a6b8563fd869d81174f297a68e2779		
<b>Warnings:</b>					
<b>Information:</b>					
3	Non Patent Literature	ExA19-231Chart-Raleigh381PCTPub.pdf	3858490	no	130
			cd14894261838b260f08f5465125888fa403147e		
<b>Warnings:</b>					
<b>Information:</b>					
4	Non Patent Literature	ExA20-231PatentInvalidityChart-Raleigh271.pdf	2718849	no	97
			fcfd04b8fa1148ea7de7f5f0f5886d25e80468		
<b>Warnings:</b>					
<b>Information:</b>					
5	Non Patent Literature	ExA21-US5592490.pdf	2473500	no	69
			000d72db688f3600c8e845a7c6be1c8ad7e729be		
<b>Warnings:</b>					
<b>Information:</b>					
6	Non Patent Literature	ExA22-Forwardlinkantennadiversity.pdf	640188	no	20
			a2367b675e6546d215d1ff95f1fbc1aa7feea02d		
<b>Warnings:</b>					
<b>Information:</b>					
7	Non Patent Literature	ExA23-231-PatentInvalidityChart-Gerlach.pdf	905173	no	30
			790cb3e30e32c2ed0ff2393ed2df79e4543962bc		
<b>Warnings:</b>					
<b>Information:</b>					
8	Non Patent Literature	ExA24-CapacityImprovementOfBase-station.pdf	353248	no	12
			6d9f80f88a489b341b6760ae974e2b068043e5c26		
<b>Warnings:</b>					
<b>Information:</b>					

9	Non Patent Literature	ExA25- AdaptiveAntennaTransmission. pdf	507605	no	17
			5a4ff2cf356e25c2a772a721ba4c44e9249d 147		
<b>Warnings:</b>					
<b>Information:</b>					
10	Non Patent Literature	ExA26- AnOverviewOfSmartAntennaTe chnology.pdf	2157561	no	75
			a2d1fd2b2e43ade2c75a3f95360f6e5b16fd 8947		
<b>Warnings:</b>					
<b>Information:</b>					
11	Non Patent Literature	ExA27- SmartAntennasForBattlefield. pdf	1663833	no	69
			cde7aae947bb2c81e0866a6bc3a46c1efeaaf e0a6		
<b>Warnings:</b>					
<b>Information:</b>					
12	Non Patent Literature	ExA28-231ClaimChart- ExperimentalStudies.pdf	2971865	no	86
			c876ab148d6b67319eee253332b60b95b1 e070fa		
<b>Warnings:</b>					
<b>Information:</b>					
13	Non Patent Literature	ExA29-231PatentInvalidityChar t-Gerlach93.pdf	860009	no	33
			c810721ce982faa161bec220bd2e0ef02a71 7524		
<b>Warnings:</b>					
<b>Information:</b>					
14	Non Patent Literature	ExA30-231ClaimChart- ArrayCommIntelllicell.pdf	1904040	no	48
			9befded76842120e8aed4434d74d995b8f 6e5ce		
<b>Warnings:</b>					
<b>Information:</b>					
15	Non Patent Literature	ExB1-US5095531.pdf	3280056	no	107
			1f27105050754c31aaa01937ed2df27b06f2 3c1e		
<b>Warnings:</b>					
<b>Information:</b>					

16	Non Patent Literature	ExB2-US5602555.pdf	875265	no	32
			32f3dbfdac34d957a0d351682b3fd6edaabc973d		
<b>Warnings:</b>					
<b>Information:</b>					
17	Non Patent Literature	ExB3-US5603089.pdf	718222	no	27
			8c82cdf19c4255ca93bc191d17a491ea3cf5ac37		
<b>Warnings:</b>					
<b>Information:</b>					
18	Non Patent Literature	ExB4-US5649293.pdf	778153	no	25
			8437fd85e773a4e812416046cf91d7963f9ad8fc		
<b>Warnings:</b>					
<b>Information:</b>					
19	Non Patent Literature	ExB5-US5886988.pdf	2281270	no	53
			253be0e7a9ef741f19b4c7ab9be80166c0fa6bb7		
<b>Warnings:</b>					
<b>Information:</b>					
20	Non Patent Literature	ExB6-US5890067.pdf	1107132	no	31
			8783dee8d097409754587c96fac62714262e1d9		
<b>Warnings:</b>					
<b>Information:</b>					
21	Non Patent Literature	ExB7-US5966094.pdf	1188833	no	30
			b81ede31a5204a3d8760c64ff4919611650a43d5		
<b>Warnings:</b>					
<b>Information:</b>					
22	Non Patent Literature	ExB8-US6233466.pdf	1937123	no	59
			949352d250d94fc62d9f3a64b2669f8ec0dc64d		
<b>Warnings:</b>					
<b>Information:</b>					

23	Non Patent Literature	ExB9-US6345188.pdf	2397254	no	92
			3f79cea89947405ddb9f44c1d26d1fe913e4ea5d		
<b>Warnings:</b>					
<b>Information:</b>					
24	Non Patent Literature	ExB10-US6667712.pdf	1678187	no	54
			a282287436ec40ccd5b9bbaf3ad8666f42fc06e3		
<b>Warnings:</b>					
<b>Information:</b>					
25	Non Patent Literature	ExB11-US6687492.pdf	1448881	no	49
			a9bb15968c0b8f43cf2df2bb5d694483a693762d		
<b>Warnings:</b>					
<b>Information:</b>					
26	Non Patent Literature	ExB12-US6694154.pdf	1901139	no	51
			ab982462d6329efec5d801255ef4c2380df6fabd		
<b>Warnings:</b>					
<b>Information:</b>					
27	Non Patent Literature	ExB13-20020034967.pdf	2041338	no	62
			a70f5d9c140f6288b756d402aa37c16ec2fc66ef		
<b>Warnings:</b>					
<b>Information:</b>					
28	Non Patent Literature	ExB14-US6850741.pdf	2963064	no	106
			7ace54faff66ebce92d2dbc098cd95fe4c359714		
<b>Warnings:</b>					
<b>Information:</b>					
29	Non Patent Literature	ExB15-US7031336.pdf	1141653	no	38
			c4f1608e6c2bfb28806697ceee8839ab222ccfba8		
<b>Warnings:</b>					
<b>Information:</b>					

30	Non Patent Literature	ExB16-US7054662.pdf	2721277	no	118
			90e1fb178133a857a41f7f7d8b12fc74937d ec5		
<b>Warnings:</b>					
<b>Information:</b>					
31	Non Patent Literature	ExB17-US7289826.pdf	2558881	no	54
			a52895b5edd4a40d3e41c15438d9c777484 3f685		
<b>Warnings:</b>					
<b>Information:</b>					
32	Non Patent Literature	ExB18-US7346365.pdf	2603384	no	55
			ee5f08eb9b5fa550330c87b927a3d5c0b5a 6810c		
<b>Warnings:</b>					
<b>Information:</b>					
33	Non Patent Literature	ExB19-US0030017853.pdf	1632663	no	50
			4cae112de291f12ada1e34cb5b997d944 7277f		
<b>Warnings:</b>					
<b>Information:</b>					
34	Non Patent Literature	ExB20-US6795409.pdf	2620348	no	91
			89bc95d2615c8e513a3276bceea162d7715 66ba5		
<b>Warnings:</b>					
<b>Information:</b>					
35	Non Patent Literature	ExB21- USPatentAppPub2001_003360 0A1-Yang.pdf	4105685	no	140
			e4ba5fc7dfa89435fec23d17786088e34081 68c6		
<b>Warnings:</b>					
<b>Information:</b>					
36	Non Patent Literature	ExB22-WO0038455.pdf	1545059	no	43
			e5e61c802407664f58261dec7c93c9e9331a 4af0		
<b>Warnings:</b>					
<b>Information:</b>					

37	Non Patent Literature	ExB23- PCTWO9921391Publication- Andersson.pdf	2112017	no	72
			b793d83d574b9c68d3f82d8bd7e2e8232717b84e		
<b>Warnings:</b>					
<b>Information:</b>					
38	Non Patent Literature	ExB24-US7062294.pdf	2147843	no	76
			b580cdf8d8b2538dbafa7d221b40f26b46d6b9c0		
<b>Warnings:</b>					
<b>Information:</b>					
39	Non Patent Literature	ExB25- ResourceManagementInThirdG eneration.pdf	843251	no	29
			3c26e5c8ce1b94e67cfe9eb7acb370f438dc664		
<b>Warnings:</b>					
<b>Information:</b>					
40	Non Patent Literature	ExB26- AdaptiveTransmittingAntenna. pdf	740352	no	27
			d9df8206b69bd70877fd739da7a0c52fe40d9e2		
<b>Warnings:</b>					
<b>Information:</b>					
41	Non Patent Literature	ExB27-ArraycommIntellicell.pdf	1287990	no	41
			893069f606725dd836e27b9c0f192555ac997de		
<b>Warnings:</b>					
<b>Information:</b>					
42	Non Patent Literature	ExC1-US5095531.pdf	2251607	no	63
			ef566139e32c6bb7174f0026cc2c302cd427968		
<b>Warnings:</b>					
<b>Information:</b>					
43	Non Patent Literature	ExC2-US5602555.pdf	382351	no	14
			3c8c7caa1d413c715444acd81c1567e500714de3		
<b>Warnings:</b>					
<b>Information:</b>					



44	Non Patent Literature	ExC3-US5603089.pdf	278724	no	11
			8b9d3d5f3124096f3d27e97f6db25c80b00f e18e		
<b>Warnings:</b>					
<b>Information:</b>					
45	Non Patent Literature	ExC4-US5649293.pdf	421438	no	12
			b0f47bb734c8eb94bfcbb22bbe3f2cbbcfa c345		
<b>Warnings:</b>					
<b>Information:</b>					
46	Non Patent Literature	ExC5-US5886988.pdf	1274170	no	28
			7ee9badf7fcd32917bf262037c2650821c15 9aeb		
<b>Warnings:</b>					
<b>Information:</b>					
47	Non Patent Literature	ExC6-US5890067.pdf	968099	no	17
			b3c698292d966baa6a3c4bde3e6966d77e4 0ff81		
<b>Warnings:</b>					
<b>Information:</b>					
48	Non Patent Literature	ExC7-US5966094.pdf	706511	no	15
			6259969efce958fa6279914780e9670e7065a af40		
<b>Warnings:</b>					
<b>Information:</b>					
49	Non Patent Literature	ExC8-US6233466.pdf	1117923	no	31
			5ba5fdc7ccacff201dff3aaa05ad767e21508 26		
<b>Warnings:</b>					
<b>Information:</b>					
50	Non Patent Literature	ExC9-US6345188.pdf	1526373	no	59
			1792890d0fefc378755f19c9bbad9b5b79ff a4e		
<b>Warnings:</b>					
<b>Information:</b>					

51	Non Patent Literature	ExC10-US6667712.pdf	1124293	no	33
			4d9c817d2f0b7698b660e30507c0b5932960a990		
<b>Warnings:</b>					
<b>Information:</b>					
52	Non Patent Literature	ExC11-US6687492.pdf	760051	no	29
			c99e7424e684b310543facfa0672f6f59522e00		
<b>Warnings:</b>					
<b>Information:</b>					
53	Non Patent Literature	ExC12-US6694154.pdf	1176761	no	24
			9b19bc06d8ca32564afb9b066360f23891b3d745		
<b>Warnings:</b>					
<b>Information:</b>					
54	Non Patent Literature	ExC13-US20020034967.pdf	1504260	no	44
			4ff121eb47b0456f40fd472d65f5d06cb7b7eaff		
<b>Warnings:</b>					
<b>Information:</b>					
55	Non Patent Literature	ExC14-US6850741.pdf	1696158	no	61
			08483979365b0490ac532a0ec91fe7f9d0394809		
<b>Warnings:</b>					
<b>Information:</b>					
56	Non Patent Literature	ExC15-US7031336.pdf	638514	no	19
			bc7311fd57df2e61c2665e497ea99ff9534b9d6		
<b>Warnings:</b>					
<b>Information:</b>					
57	Non Patent Literature	ExC16-US7054662.pdf	1559096	no	68
			6032edf68f70eafcedbae899e0424c6291db58b5		
<b>Warnings:</b>					
<b>Information:</b>					

58	Non Patent Literature	ExC17-US7289826.pdf	2082005	no	37
			33a9a0d23ba8a9d0fbd48849b85241785d55fb6		
<b>Warnings:</b>					
<b>Information:</b>					
59	Non Patent Literature	ExC18-US7346365.pdf	2060340	no	36
			a31f9a7c0f6df0e8186e01b468f4ba421bf27bad		
<b>Warnings:</b>					
<b>Information:</b>					
60	Non Patent Literature	ExC19-20030017853.pdf	951853	no	25
			3c9ecf013483163b164e1c4895c2025308cedc13		
<b>Warnings:</b>					
<b>Information:</b>					
<b>Total Files Size (in bytes):</b>				103187756	
<p><b>This Acknowledgement Receipt evidences receipt on the noted date by the USPTO of the indicated documents, characterized by the applicant, and including page counts, where applicable. It serves as evidence of receipt similar to a Post Card, as described in MPEP 503.</b></p> <p><b><u>New Applications Under 35 U.S.C. 111</u></b>  <b>If a new application is being filed and the application includes the necessary components for a filing date (see 37 CFR 1.53(b)-(d) and MPEP 506), a Filing Receipt (37 CFR 1.54) will be issued in due course and the date shown on this Acknowledgement Receipt will establish the filing date of the application.</b></p> <p><b><u>National Stage of an International Application under 35 U.S.C. 371</u></b>  <b>If a timely submission to enter the national stage of an international application is compliant with the conditions of 35 U.S.C. 371 and other applicable requirements a Form PCT/DO/EO/903 indicating acceptance of the application as a national stage submission under 35 U.S.C. 371 will be issued in addition to the Filing Receipt, in due course.</b></p> <p><b><u>New International Application Filed with the USPTO as a Receiving Office</u></b>  <b>If a new international application is being filed and the international application includes the necessary components for an international filing date (see PCT Article 11 and MPEP 1810), a Notification of the International Application Number and of the International Filing Date (Form PCT/RO/105) will be issued in due course, subject to prescriptions concerning national security, and the date shown on this Acknowledgement Receipt will establish the international filing date of the application.</b></p>					

## Electronic Acknowledgement Receipt

<b>EFS ID:</b>	31108015
<b>Application Number:</b>	15495539
<b>International Application Number:</b>	
<b>Confirmation Number:</b>	1050
<b>Title of Invention:</b>	DIRECTED WIRELESS COMMUNICATION
<b>First Named Inventor/Applicant Name:</b>	Marcus Da Silva
<b>Customer Number:</b>	20995
<b>Filer:</b>	Glen L. Nuttall/Mariel Boyan
<b>Filer Authorized By:</b>	Glen L. Nuttall
<b>Attorney Docket Number:</b>	XRCOM.001C5
<b>Receipt Date:</b>	01-DEC-2017
<b>Filing Date:</b>	24-APR-2017
<b>Time Stamp:</b>	17:02:29
<b>Application Type:</b>	Utility under 35 USC 111(a)

### Payment information:

Submitted with Payment	no
------------------------	----

### File Listing:

Document Number	Document Description	File Name	File Size(Bytes)/ Message Digest	Multi Part /.zip	Pages (if appl.)
1	Non Patent Literature	ExC20-US6795409.pdf	1644859  <small>6cd7c5cf45b15b127f009014a85df27622c8c1ce</small>	no	53

### Warnings:

<b>Information:</b>					
2	Non Patent Literature	ExC21- USPatentAppPub2001_003360 0A1-Yang.pdf	1822443	no	57
			39b8f2063a2754648e96bfa6075cd0a095b ebbba		
<b>Warnings:</b>					
<b>Information:</b>					
3	Non Patent Literature	ExC22-WO0038455.pdf	926936	no	22
			e7f31d8110f95cbe3c487ccb3d3b684b0a a7eb		
<b>Warnings:</b>					
<b>Information:</b>					
4	Non Patent Literature	ExC23- PCTWO9921391Publication- Andersson.pdf	925519	no	28
			3a1932a0f0e99537e4e42628cea5992de6a 574b3		
<b>Warnings:</b>					
<b>Information:</b>					
5	Non Patent Literature	ExC24-US7062294.pdf	1432401	no	45
			e6b773b25c88cd9ad5992bfeeb1abf2d57 d3274		
<b>Warnings:</b>					
<b>Information:</b>					
6	Non Patent Literature	ExC25-728PatentInvalidityChar t-Marikar.pdf	536786	no	17
			73b1c7898e9510ce8ea2b5b744bd9b3b7 bfe3b3		
<b>Warnings:</b>					
<b>Information:</b>					
7	Non Patent Literature	ExC26- AdaptiveTransmittingAntenna Arrays.pdf	433050	no	15
			1339ab52773f2d90a170010547c6d08bf7 be65e		
<b>Warnings:</b>					
<b>Information:</b>					
8	Non Patent Literature	ExC27-ArrayCommIntellicell. pdf	679231	no	23
			1804f0a504bd240921a3f09e79f7fc2ad0c 7c62		
<b>Warnings:</b>					
<b>Information:</b>					
<b>Total Files Size (in bytes):</b>			8401225		

**This Acknowledgement Receipt evidences receipt on the noted date by the USPTO of the indicated documents, characterized by the applicant, and including page counts, where applicable. It serves as evidence of receipt similar to a Post Card, as described in MPEP 503.**

**New Applications Under 35 U.S.C. 111**

**If a new application is being filed and the application includes the necessary components for a filing date (see 37 CFR 1.53(b)-(d) and MPEP 506), a Filing Receipt (37 CFR 1.54) will be issued in due course and the date shown on this Acknowledgement Receipt will establish the filing date of the application.**

**National Stage of an International Application under 35 U.S.C. 371**

**If a timely submission to enter the national stage of an international application is compliant with the conditions of 35 U.S.C. 371 and other applicable requirements a Form PCT/DO/EO/903 indicating acceptance of the application as a national stage submission under 35 U.S.C. 371 will be issued in addition to the Filing Receipt, in due course.**

**New International Application Filed with the USPTO as a Receiving Office**

**If a new international application is being filed and the international application includes the necessary components for an international filing date (see PCT Article 11 and MPEP 1810), a Notification of the International Application Number and of the International Filing Date (Form PCT/RO/105) will be issued in due course, subject to prescriptions concerning national security, and the date shown on this Acknowledgement Receipt will establish the international filing date of the application.**

## SCORE Placeholder Sheet for IFW Content

Application Number: 15495539

Document Date: 10/05/2017

The presence of this form in the IFW record indicates that the following document type was received in electronic format on the date identified above. This content is stored in the SCORE database.

Since this was an electronic submission, there is no physical artifact folder, no artifact folder is recorded in PALM, and no paper documents or physical media exist. The TIFF images in the IFW record were created from the original documents that are stored in SCORE.

- Drawing

At the time of document entry (noted above):

- USPTO employees may access SCORE content via eDAN using the Supplemental Content tab, or via the SCORE web page.
- External customers may access SCORE content via PAIR using the Supplemental Content tab.

Form Revision Date: August 26, 2013

**IN THE UNITED STATES PATENT AND TRADEMARK OFFICE**

First Inventor: Marcus Da Silva

Application No.: 15/495,539

Filing Date: April 24, 2017

For: DIRECTED WIRELESS COMMUNICATION

Examiner: Gina M. MCKIE

Art Unit: 2631

Confirmation No.: 1050

**AMENDMENT AND RESPONSE TO NON-FINAL OFFICE ACTION**

**Mail Stop Amendment**

Commissioner for Patents  
P.O. Box 1450  
Alexandria, VA 22313-1450

Dear Commissioner:

In response to the Non-Final Office Action issued on July 5, 2017, Applicant amends this application as follows:

**Amendments to the Specification** begin on page 2 of this paper.

**Amendments to the Drawings** begins on page 5 of this paper.

**Listing of the Claims** begins on page 6 of this paper.

**Remarks/Arguments** begin on page 11 of this paper.



**Application No.:** 15/495,539  
**Filing Date:** April 24, 2017

## AMENDMENTS TO THE SPECIFICATION

**Please amend paragraph [0032] of the specification as follows:**

[0032] FIG. 1 illustrates an exemplary wireless communications ~~environ-merit~~ environment 100 that is generally representative of any number of different types of wireless communications environments, including but not limited to those pertaining to wireless local area networks (LANs) or wide area networks (WANs) (e.g., Wi-Fi compatible) technology, cellular technology, trunking technology, and the like. In wireless communications environment 100, an access station 102 communicates with remote client devices 104(1), 104(2), . . . , 104(N) via wireless communication or communication links 106(1), 106(2), . . . , 106(N), respectively. Although not required, access station 102 is typically fixed, and remote client devices 104 may be fixed or mobile. Although only three remote client devices 104 are shown, access station 102 can wirelessly communicate with any number of different client devices 104.

**Please amend paragraph [0065] of the specification as follows:**

[0065] The channel assignments coordinated by the signal control and coordination logic 304 provide[[s]] the best channel assignment for a signal based on given measurement information. Parameters of a channel assignment algorithm include:

**Please amend paragraph [0085] of the specification as follows:**

[0085]  $N_{e_{ij}}(t)$  which is a number of uplink data packets with Physical Layer Convergence Procedure (PLCP) or data Cyclic Redundancy Check (CRC) errors in the  $i$ th beam on the  $j$ th channel and which is measured by the scanning receiver 822 and averaged over the *MeasurementDuration* period. This is also referred to as the Unidentified Interference Metric (UIM); and

**Please amend paragraph [0099] of the specification as follows:**

[0099] A combination index  $R$  with the least peak communication load is then selected such that  $PL_{max}(R) = \min \{PL_{max}(k)\}$  where  $(0 \leq k \leq 71)$  which is the combination of channels and beams that minimize the peak load on any channel. If the peak load on a channel is not less than

**Application No.:** 15/495,539  
**Filing Date:** April 24, 2017

the *PeakLoadLimit*, then a three channel assignment can be implemented. Initially, the thirteen communication beams are divided into three blocks of which there are sixty-six possible combinations. For each combination, the channel selections can be  $f_1f_6f_{11}$ ,  $f_1f_{11}f_6$ ,  $f_6f_1f_{11}$ ,  $f_6f_{11}f_1$ ,  $f_{11}f_1f_6$ , or  $f_{11}f_6f_1$  such that there are a total of three-hundred, ninety-six block and channel combinations. Assuming that the  $k$ th block-channel combination has a configuration as follows:

**Please amend paragraph [0107] of the specification as follows:**

[0107] When taking into account intermodulation such that channel combinations  $f_1f_6$  and  $f_6f_{11}$  are to be avoided, then  $f_6$  is avoided. Initially, the thirteen communication beams are divided into two blocks of which there are twelve possible combinations. For each combination, the channel selections can be  $f_1f_{11}$  and  $f_{11}f_1$  such that there are a total of twenty-four block and channel combinations. Assuming that the  $k$ th block-channel combination has a configuration as follows:

**Please amend paragraph [0132] of the specification as follows:**

[0132] The receive indicators forwarded to MAC coordinator logic 904 may be comprised of any one or more different indications from the baseband units 902. For example, the receive indicators may comprise clear channel assessment (CCA) or busy/non-busy indications. Alternatively, the receive indicators may comprise indications of signal reception based on energy signals, cross-correlation signals, data signals, other transmit and/or control signals, ~~some~~ some combination thereof, and so forth. Furthermore, a receive indicator may comprise an analog or digital indication (of one or more bits), the driving of one or more lines, the presentation of one or more messages, some combination thereof, and so forth.

**Please amend paragraph [0155] of the specification as follows:**

[0155] A busy( ) function returns a receiver indication that a channel is busy, and an error( ) function indicates that a received frame had a CRC error. A notforus( ) function indicates that a frame was not addressed to a particular station, and a ~~nav()~~ nav() function indicates that a

**Application No.:** 15/495,539  
**Filing Date:** April 24, 2017

timer has not expired. A data( ) function indicates that data is queued to send, and a short( ) function indicates that a MAC protocol data unit is shorter than an RTS Threshold and that there are additional data fragments to be sent from a current MAC controller. A more( ) function facilitates obtaining the additional data fragments.

**Application No.:** 15/495,539  
**Filing Date:** April 24, 2017

### **AMENDMENTS TO THE DRAWINGS**

Replacement sheet for Figure 16 is included in the Appendix.

**Application No.:** 15/495,539  
**Filing Date:** April 24, 2017

### LISTING OF CLAIMS

The following is a listing of the claims. No amendments have been made.

1. (Previously Presented) A receiver for use in a wireless communications system, the receiver comprising:

an antenna;

a transceiver operatively coupled to the antenna and configured to transmit and receive electromagnetic signals using the antenna; and

a processor operatively coupled to the transceiver, the processor configured to:

receive a first signal transmission from a remote station via the antenna and a second signal transmission from the remote station via the antenna simultaneously;

determine first signal information for the first signal transmission;

determine second signal information for the second signal transmission, wherein the second signal information is different than the first signal information;

determine a set of weighting values based on the first signal information and the second signal information, wherein the set of weighting values is configured to be used by the remote station to construct one or more beam-formed transmission signals; and

cause the transceiver to generate a third signal comprising content based on the set of weighting values.

2. (Previously Presented) The receiver as recited in Claim 1, wherein the antenna comprises a first antenna element and a second antenna element, and

wherein the processor is further configured to:

receive the first signal transmission from the remote station via the first antenna element and the second signal transmission from the remote station via the second antenna element simultaneously; and

**Application No.:** 15/495,539  
**Filing Date:** April 24, 2017

cause the transceiver to transmit the third signal to the remote station via the antenna.

3. (Original) The receiver as recited in Claim 1, wherein the first signal transmission and the second signal transmission comprise electromagnetic signals comprising one or more transmission peaks and one or more transmission nulls.

4. (Original) The receiver as recited in Claim 1, wherein the first signal transmission and the second signal transmission are directional transmissions.

5. (Original) The receiver as recited in Claim 1, wherein the set of weighting values is further based on one or more of: a transmit power level, a data transmit rate, an antenna direction, quality of service data, or timing data.

6. (Previously Presented) The receiver as recited in Claim 1, wherein the content comprises data configured to be used by the remote station to modify the placement of one or more transmission peaks and one or more transmission nulls in a subsequent signal transmission.

7. (Previously Presented) The receiver as recited in Claim 1, wherein the processor is further configured to:

determine a plurality of signal strength indications for the first signal transmission;

determine a first signal strength average based on the plurality of signal strength indications for the first signal transmission;

determine a plurality of signal strength indications for the second signal transmission;

determine a second signal strength average based on the plurality of signal strength indications for the second signal transmission; and

cause the transceiver to generate a fourth signal based on the first signal strength average and the second signal strength average.

**Application No.:** 15/495,539  
**Filing Date:** April 24, 2017

8. (Previously Presented) The receiver as recited in Claim 7, wherein the processor is further configured to: cause the transceiver to transmit the fourth signal to the remote station via the antenna.

9. (Previously Presented) A method in a wireless communications system, the method comprising:

receiving a first signal transmission from a remote station via a first antenna element of an antenna and a second signal transmission from the remote station via a second antenna element of the antenna simultaneously;

determining first signal information for the first signal transmission;

determining second signal information for the second signal transmission, wherein the second signal information is different than the first signal information;

determining a set of weighting values based on the first signal information and the second signal information, wherein the set of weighting values is configured to be used by the remote station to construct one or more beam-formed transmission signals; and

transmitting to the remote station a third signal comprising content based on the set of weighting values.

10. (Previously Presented) The method as recited in Claim 9, further comprising: transmitting the third signal to the remote station via the antenna.

11. (Original) The method as recited in Claim 9, wherein the first signal transmission and the second signal transmission comprise electromagnetic signals comprising one or more transmission peaks and one or more transmission nulls.

12. (Original) The method as recited in Claim 9, wherein the first signal transmission and the second signal transmission are directional transmissions.

13. (Original) The method as recited in Claim 9, wherein the set of weighting values is further based on one or more of: a transmit power level, a data transmit rate, an antenna direction, quality of service data, or timing data.

**Application No.:** 15/495,539  
**Filing Date:** April 24, 2017

14. (Previously Presented) The method as recited in Claim 9, wherein the content comprises data configured to be used by the remote station to modify the placement of one or more transmission peaks and one or more transmission nulls in a subsequent signal transmission.

15. (Previously Presented) The method as recited in Claim 9, further comprising:  
determining a plurality of signal strength indications for the first signal transmission;  
determining a first signal strength average based on the plurality of signal strength indications for the first signal transmission;  
determining a plurality of signal strength indications for the second signal transmission;  
determining a second signal strength average based on the plurality of signal strength indications for the second signal transmission; and  
generating a fourth signal based on the first signal strength average and the second signal strength average.

16. (Previously Presented) The method as recited in Claim 15, further comprising: causing the transceiver to transmit the fourth signal to the remote station via the antenna.

17. (Previously Presented) An apparatus for use in a wireless communications system, the apparatus comprising:  
an antenna;  
a transceiver operatively coupled to the antenna; and  
a processor operatively coupled to the transceiver, the processor configured to:  
receive a first signal transmission from a remote station via the antenna, the first signal transmission comprising first signal information;  
receive a second signal transmission from the remote station via the antenna, the second signal transmission comprising second signal information;  
determine a set of weighting values based on the first signal information and the second signal information, wherein the set of weighting values is



**Application No.:** 15/495,539  
**Filing Date:** April 24, 2017

configured to be used by the remote station to construct one or more beam-formed transmission signals;

cause the transceiver to generate a third signal comprising content based on the set of weighting values.

18. (Original) The apparatus as recited in Claim 17, wherein the first signal transmission and the second signal transmission comprise electromagnetic signals comprising one or more transmission peaks and one or more transmission nulls.

19. (Original) The apparatus as recited in Claim 17, wherein the first signal information comprises one or more of: a transmit power level, a data transmit rate, an antenna direction, quality of service data, or timing data.

20. (Previously Presented) The apparatus as recited in Claim 17, wherein the antenna comprises a first antenna element and a second antenna element, and wherein the first antenna element and the second antenna element are directional antenna elements.

**Application No.:** 15/495,539  
**Filing Date:** April 24, 2017

## REMARKS

This paper is responsive to the Office Action dated on July 5, 2017 (the “Office Action”). Claims 1-20 remain pending. Applicant has not amended the claims. In view of the following remarks, Applicant respectfully submits that the application is in condition for allowance.

### Discussion of Amendments to the Specification

Applicant has corrected typographical errors as indicated above. No new matter has been added by these amendments.

### Discussion of Amendments to the Drawings

Applicant is submitting replacement Figure 16 to correct the direction of the arrow for transition 1610. No new matter has been added by this amendment.

### Discussion of Claim Rejections under 35 U.S.C. § 103

The Office Action rejected claims 1-20 under 35 U.S.C. § 103 as being unpatentable over U.S. Patent Publication No. 2002/0158801 (“Crilly”) in view of U.S. Patent No. 6,714,584 (“Ishii”). Applicant respectfully traverses these rejections.

The Office Action relies on Ishii as disclosing the following emphasized limitations of claim 1: “receive a first signal transmission from a remote station via the antenna and a second signal transmission *from the remote station* via the antenna simultaneously.” In particular, the Office Action relies on the following disclosure in Ishii:

Signals received at different directional antennas 1-1 to 1-N are introduced into delay circuits 2-2 to 2-M. A directivity in a direction, for example, at every equal angle (360/N degrees) is assigned to each of antennas 1-1 to 1-N, respectively. Delay circuit 2-1 has a time delay of 0 and thus is omitted in the drawings. Delay circuits 2-2 to 2-M adaptively delay the received signals so that receivers 3-1 to 3-M may receive simultaneously the desired signal components incoming at different timings.

*Ishii*, column 3, lines 15-23.

However, the cited portions of *Ishii* do not disclose or suggest receiving signal components from the same transmitter. In fact, *Ishii* discloses that the “present invention relates to CDMA (Code Division Multiple Access) adaptive antenna . . . for separating and synthesizing

**Application No.:** 15/495,539  
**Filing Date:** April 24, 2017

a plural of desired signal components incoming at a plural of different timings and from a *plural of different directions at each timing.*” *Id.*, column 1, lines 8-13 (emphasis added). In Ishii, signal components come from a plurality of different directions, and are thus associated with *different* transmitters. In contrast, claim 1 recites “receive a first signal transmission from *a* remote station via the antenna and a second signal transmission from *the* remote station” (emphasis added).

For at least these reasons, Applicant respectfully submits that Crilly in combination with Ishii does not disclose or suggest claim 1 and respectfully requests withdrawal of the rejection.

Independent claim 9 recites, among other limitations, “receiving a first signal transmission from a remote station via a first antenna element of an antenna and a second signal transmission from the remote station.” Independent claim 17 recites, among other limitations, “receive a first signal transmission from a remote station via the antenna” and “receive a second signal transmission from the remote station via the antenna.” At least for the foregoing reasons, Applicant respectfully submits that Crilly in combination with Ishii does not disclose or suggest claims 9 and 17 and respectfully requests withdrawal of the rejection.

In addition, each of the dependent claims depends from a patentable independent claim and also recites limitations that represent additional patentable distinctions over the cited references. Accordingly, Applicant respectfully submits that the dependent claims are patentable and requests withdrawal of the rejections.

#### Conclusion

For the foregoing reasons, Applicant respectfully submits that the application is in condition for allowance. Should any issues remain which may be addressed in a phone call, the Examiner is invited to call the undersigned at 949-721-5308.

#### No Disclaimers or Disavowals

Although the present communication may include alterations to the application or claims, or characterizations of claim scope or referenced art, Applicant is not conceding in this application that previously pending claims are not patentable over the cited references. Rather, any alterations or characterizations are being made to facilitate expeditious prosecution of this

**Application No.: 15/495,539**  
**Filing Date: April 24, 2017**

application. Applicant reserves the right to pursue at a later date any previously pending or other broader or narrower claims that capture any subject matter supported by the present disclosure, including subject matter found to be specifically disclaimed herein or by any prior prosecution. Accordingly, reviewers of this or any parent, child or related prosecution history shall not reasonably infer that Applicant has made any disclaimers or disavowals of any subject matter supported by the present application.

Please charge any additional fees, including any fees for additional extension of time, or credit overpayment to Deposit Account No. 11-1410

Respectfully submitted,

KNOBBE, MARTENS, OLSON & BEAR, LLP

Dated: October 5, 2017

By: Vladislav Z. Teplitskiy  
Vladislav Z. Teplitskiy  
Registration No. 68,069  
Registered Practitioner  
Customer No. 20995  
(949) 760-0404

26731652

## Electronic Acknowledgement Receipt

<b>EFS ID:</b>	30574804
<b>Application Number:</b>	15495539
<b>International Application Number:</b>	
<b>Confirmation Number:</b>	1050
<b>Title of Invention:</b>	DIRECTED WIRELESS COMMUNICATION
<b>First Named Inventor/Applicant Name:</b>	Marcus Da Silva
<b>Customer Number:</b>	20995
<b>Filer:</b>	Vladislav Z. Teplitskiy/Angel Zehnder
<b>Filer Authorized By:</b>	Vladislav Z. Teplitskiy
<b>Attorney Docket Number:</b>	XRCOM.001C5
<b>Receipt Date:</b>	05-OCT-2017
<b>Filing Date:</b>	24-APR-2017
<b>Time Stamp:</b>	13:52:07
<b>Application Type:</b>	Utility under 35 USC 111(a)

### Payment information:

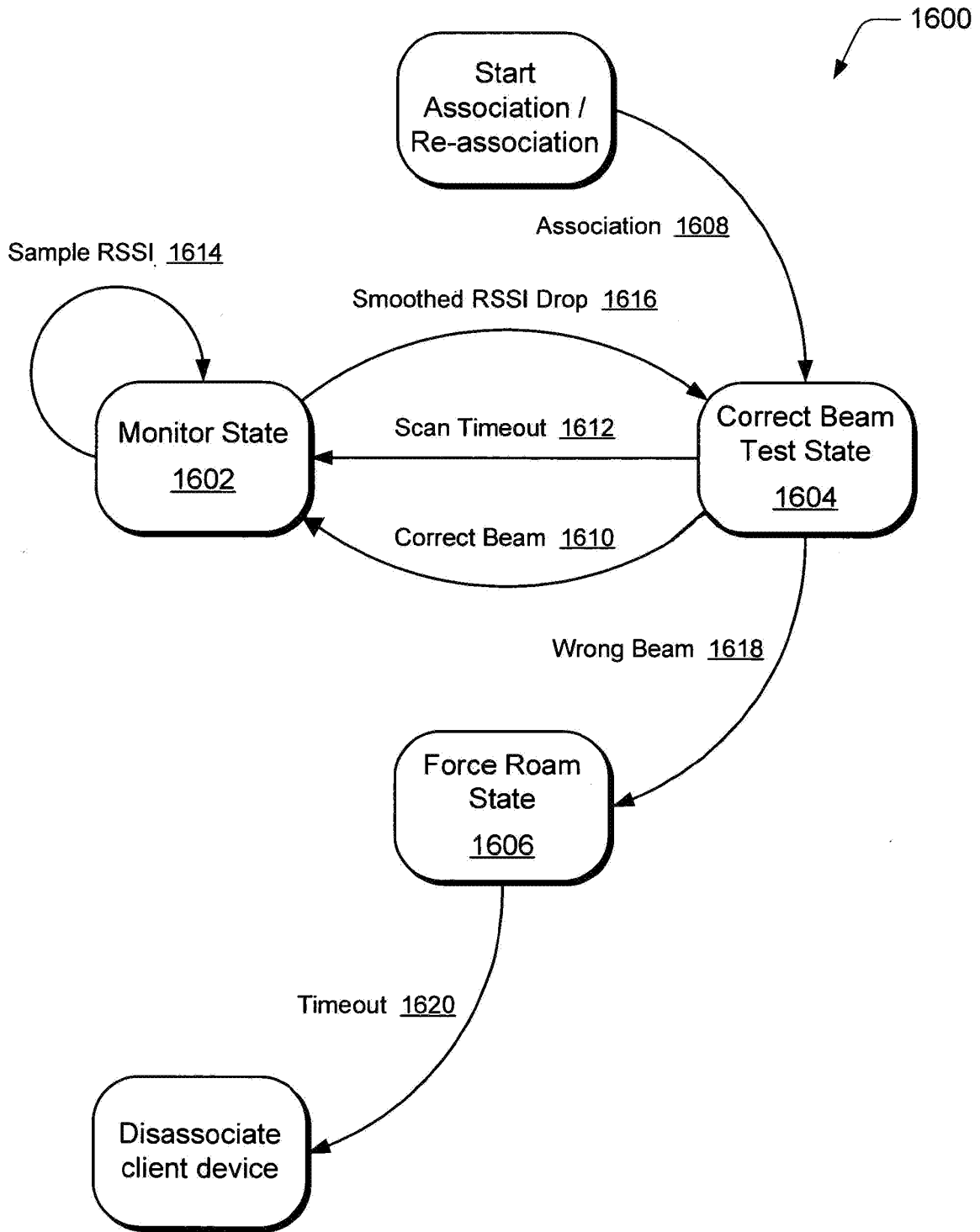
Submitted with Payment	no
------------------------	----

### File Listing:

Document Number	Document Description	File Name	File Size(Bytes)/ Message Digest	Multi Part /.zip	Pages (if appl.)
1	Drawings-other than black and white line drawings	Figures_XRCOM.pdf	737237 9dc4a8a84eec9ec8984bdf393aebca9ac06c90cc	no	1

### Warnings:

Information:					
2		Amend_XRCOM.pdf	76181	yes	13
			cbb8f08758656b4d4bd9ecdfc4c3a5378ed6cb31		
<b>Multipart Description/PDF files in .zip description</b>					
		<b>Document Description</b>	<b>Start</b>	<b>End</b>	
		Amendment/Req. Reconsideration-After Non-Final Reject	1	1	
		Specification	2	4	
		Drawings-only black and white line drawings	5	5	
		Claims	6	10	
		Applicant Arguments/Remarks Made in an Amendment	11	13	
<b>Warnings:</b>					
<b>Information:</b>					
<b>Total Files Size (in bytes):</b>			813418		
<p><b>This Acknowledgement Receipt evidences receipt on the noted date by the USPTO of the indicated documents, characterized by the applicant, and including page counts, where applicable. It serves as evidence of receipt similar to a Post Card, as described in MPEP 503.</b></p> <p><b><u>New Applications Under 35 U.S.C. 111</u></b>  <b>If a new application is being filed and the application includes the necessary components for a filing date (see 37 CFR 1.53(b)-(d) and MPEP 506), a Filing Receipt (37 CFR 1.54) will be issued in due course and the date shown on this Acknowledgement Receipt will establish the filing date of the application.</b></p> <p><b><u>National Stage of an International Application under 35 U.S.C. 371</u></b>  <b>If a timely submission to enter the national stage of an international application is compliant with the conditions of 35 U.S.C. 371 and other applicable requirements a Form PCT/DO/EO/903 indicating acceptance of the application as a national stage submission under 35 U.S.C. 371 will be issued in addition to the Filing Receipt, in due course.</b></p> <p><b><u>New International Application Filed with the USPTO as a Receiving Office</u></b>  <b>If a new international application is being filed and the international application includes the necessary components for an international filing date (see PCT Article 11 and MPEP 1810), a Notification of the International Application Number and of the International Filing Date (Form PCT/RO/105) will be issued in due course, subject to prescriptions concerning national security, and the date shown on this Acknowledgement Receipt will establish the international filing date of the application.</b></p>					



*Fig. 16*

Under the Paperwork Reduction Act of 1995, no persons are required to respond to a collection of information unless it displays a valid OMB control number.

<b>PATENT APPLICATION FEE DETERMINATION RECORD</b> Substitute for Form PTO-875			Application or Docket Number <b>15/495,539</b>	Filing Date <b>04/24/2017</b>	<input type="checkbox"/> To be Mailed
ENTITY: <input type="checkbox"/> LARGE <input checked="" type="checkbox"/> SMALL <input type="checkbox"/> MICRO					
<b>APPLICATION AS FILED – PART I</b>					
(Column 1)		(Column 2)			
FOR	NUMBER FILED	NUMBER EXTRA	RATE (\$)	FEE (\$)	
<input type="checkbox"/> BASIC FEE (37 CFR 1.16(a), (b), or (c))	N/A	N/A	N/A		
<input type="checkbox"/> SEARCH FEE (37 CFR 1.16(k), (l), or (m))	N/A	N/A	N/A		
<input type="checkbox"/> EXAMINATION FEE (37 CFR 1.16(o), (p), or (q))	N/A	N/A	N/A		
TOTAL CLAIMS (37 CFR 1.16(j))	minus 20 =	*	X \$ =		
INDEPENDENT CLAIMS (37 CFR 1.16(h))	minus 3 =	*	X \$ =		
<input type="checkbox"/> APPLICATION SIZE FEE (37 CFR 1.16(s))	If the specification and drawings exceed 100 sheets of paper, the application size fee due is \$310 (\$155 for small entity) for each additional 50 sheets or fraction thereof. See 35 U.S.C. 41(a)(1)(G) and 37 CFR 1.16(s).				
<input type="checkbox"/> MULTIPLE DEPENDENT CLAIM PRESENT (37 CFR 1.16(j))					
* If the difference in column 1 is less than zero, enter "0" in column 2.			TOTAL		

<b>APPLICATION AS AMENDED – PART II</b>							
(Column 1)		(Column 2)		(Column 3)			
<b>AMENDMENT</b>	<b>10/05/2017</b>	CLAIMS REMAINING AFTER AMENDMENT		HIGHEST NUMBER PREVIOUSLY PAID FOR	PRESENT EXTRA	RATE (\$)	ADDITIONAL FEE (\$)
	Total (37 CFR 1.16(i))	* 20	Minus	** 20	= 0	X \$40 =	0
	Independent (37 CFR 1.16(h))	* 3	Minus	***3	= 0	X \$210 =	0
	<input type="checkbox"/> Application Size Fee (37 CFR 1.16(s))						
	<input type="checkbox"/> FIRST PRESENTATION OF MULTIPLE DEPENDENT CLAIM (37 CFR 1.16(j))						
						TOTAL ADD'L FEE	<b>0</b>

(Column 1)		(Column 2)		(Column 3)			
<b>AMENDMENT</b>		CLAIMS REMAINING AFTER AMENDMENT		HIGHEST NUMBER PREVIOUSLY PAID FOR	PRESENT EXTRA	RATE (\$)	ADDITIONAL FEE (\$)
	Total (37 CFR 1.16(i))	*	Minus	**	=	X \$ =	
	Independent (37 CFR 1.16(h))	*	Minus	***	=	X \$ =	
	<input type="checkbox"/> Application Size Fee (37 CFR 1.16(s))						
	<input type="checkbox"/> FIRST PRESENTATION OF MULTIPLE DEPENDENT CLAIM (37 CFR 1.16(j))						
						TOTAL ADD'L FEE	

\* If the entry in column 1 is less than the entry in column 2, write "0" in column 3.  
 \*\* If the "Highest Number Previously Paid For" IN THIS SPACE is less than 20, enter "20".  
 \*\*\* If the "Highest Number Previously Paid For" IN THIS SPACE is less than 3, enter "3".  
 The "Highest Number Previously Paid For" (Total or Independent) is the highest number found in the appropriate box in column 1.

LIE  
MAMYE WAGSTAFF

This collection of information is required by 37 CFR 1.16. The information is required to obtain or retain a benefit by the public which is to file (and by the USPTO to process) an application. Confidentiality is governed by 35 U.S.C. 122 and 37 CFR 1.14. This collection is estimated to take 12 minutes to complete, including gathering, preparing, and submitting the completed application form to the USPTO. Time will vary depending upon the individual case. Any comments on the amount of time you require to complete this form and/or suggestions for reducing this burden, should be sent to the Chief Information Officer, U.S. Patent and Trademark Office, U.S. Department of Commerce, P.O. Box 1450, Alexandria, VA 22313-1450. DO NOT SEND FEES OR COMPLETED FORMS TO THIS ADDRESS. **SEND TO: Commissioner for Patents, P.O. Box 1450, Alexandria, VA 22313-1450.**  
 If you need assistance in completing the form, call 1-800-PTO-9199 and select option 2.





UNITED STATES PATENT AND TRADEMARK OFFICE

UNITED STATES DEPARTMENT OF COMMERCE  
United States Patent and Trademark Office  
Address: COMMISSIONER FOR PATENTS  
P.O. Box 1450  
Alexandria, Virginia 22313-1450  
www.uspto.gov

APPLICATION NUMBER	FILING OR 371(C) DATE	FIRST NAMED APPLICANT	ATTY. DOCKET NO./TITLE
15/495,539	04/24/2017	Marcus Da Silva	E1027.800(T).US1D1C1C3

**CONFIRMATION NO. 1050**

**POWER OF ATTORNEY NOTICE**

114581  
EIP US LLP  
2468 Historic Decatur Road  
Suite 200  
San Diego, CA 92106



Date Mailed: 09/20/2017

**NOTICE REGARDING CHANGE OF POWER OF ATTORNEY**

This is in response to the Power of Attorney filed 09/18/2017.

- The Power of Attorney to you in this application has been revoked by the applicant. Future correspondence will be mailed to the new address of record(37 CFR 1.33).

Questions about the contents of this notice and the requirements it sets forth should be directed to the Office of Data Management, Application Assistance Unit, at (571) 272-4000 or (571) 272-4200 or 1-888-786-0101.

/zretta/



UNITED STATES PATENT AND TRADEMARK OFFICE

UNITED STATES DEPARTMENT OF COMMERCE  
United States Patent and Trademark Office  
Address: COMMISSIONER FOR PATENTS  
P.O. Box 1450  
Alexandria, Virginia 22313-1450  
www.uspto.gov

APPLICATION NUMBER	FILING OR 371(C) DATE	FIRST NAMED APPLICANT	ATTY. DOCKET NO./TITLE
15/495,539	04/24/2017	Marcus Da Silva	XRCOM.001C5

**CONFIRMATION NO. 1050**

**POA ACCEPTANCE LETTER**

20995  
KNOBBE MARTENS OLSON & BEAR LLP  
2040 MAIN STREET  
FOURTEENTH FLOOR  
IRVINE, CA 92614



Date Mailed: 09/20/2017

**NOTICE OF ACCEPTANCE OF POWER OF ATTORNEY**

This is in response to the Power of Attorney filed 09/18/2017.

The Power of Attorney in this application is accepted. Correspondence in this application will be mailed to the above address as provided by 37 CFR 1.33.

Questions about the contents of this notice and the requirements it sets forth should be directed to the Office of Data Management, Application Assistance Unit, at (571) 272-4000 or (571) 272-4200 or 1-888-786-0101.

/zretta/

## TRANSMITTAL FOR POWER OF ATTORNEY TO ONE OR MORE REGISTERED PRACTITIONERS

NOTE: This form is to be submitted with the Power of Attorney by Applicant form (PTO/AIA/82B) to identify the application to which the Power of Attorney is directed, in accordance with 37 CFR 1.5, unless the application number and filing date are identified in the Power of Attorney by Applicant form. If neither form PTO/AIA/82A nor form PTO/AIA82B identifies the application to which the Power of Attorney is directed, the Power of Attorney will not be recognized in the application.

Application Number	15/495539
Filing Date	24 April 2017
First Named Inventor	Marcus Da Silva
Title	DIRECTED WIRELESS COMMUNICATION
Art Unit	2631
Examiner Name	McKie, Gina M.
Attorney Docket Number	XRCOM.001C5

SIGNATURE of Applicant or Patent Practitioner			
Signature	/Vladislav Z. Teplitkiy/	Date (Optional)	
Name	Vladislav Z. Teplitkiy	Registration Number	68,069
Title (if Applicant is a juristic entity)			
Applicant Name (if Applicant is a juristic entity)			

**NOTE:** This form must be signed in accordance with 37 CFR 1.33. See 37 CFR 1.4(d) for signature requirements and certifications. If more than one applicant, use multiple forms.

\*Total of 1 forms are submitted.

This collection of information is required by 37 CFR 1.131, 1.32, and 1.33. The information is required to obtain or retain a benefit by the public which is to file (and by the USPTO to process) an application. Confidentiality is governed by 35 U.S.C. 122 and 37 CFR 1.11 and 1.14. This collection is estimated to take 3 minutes to complete, including gathering, preparing, and submitting the completed application form to the USPTO. Time will vary depending upon the individual case. Any comments on the amount of time you require to complete this form and/or suggestions for reducing this burden, should be sent to the Chief Information Officer, U.S. Patent and Trademark Office, U.S. Department of Commerce, P.O. Box 1450, Alexandria, VA 22313-1450. DO NOT SEND FEES OR COMPLETED FORMS TO THIS ADDRESS. SEND TO: Commissioner for Patents, P.O. Box 1450, Alexandria, VA 22313-1450.

*If you need assistance in completing the form, call 1-800-PTO-9199 and select option 2.*

## POWER OF ATTORNEY BY APPLICANT

I hereby revoke all previous powers of attorney given in the application identified in either the attached transmittal letter or the boxes below.

Application Number	Filing Date

(Note: The boxes above may be left blank if information is provided on form PTO/AIA/82A.)

- I hereby appoint the Patent Practitioner(s) associated with the following Customer Number as my/our attorney(s) or agent(s), and to transact all business in the United States Patent and Trademark Office connected therewith for the application referenced in the attached transmittal letter (form PTO/AIA/82A) or identified above: 20995
- OR**
- I hereby appoint Practitioner(s) named in the attached list (form PTO/AIA/82C) as my/our attorney(s) or agent(s), and to transact all business in the United States Patent and Trademark Office connected therewith for the patent application referenced in the attached transmittal letter (form PTO/AIA/82A) or identified above. (Note: Complete form PTO/AIA/82C.)

**Please recognize or change the correspondence address for the application identified in the attached transmittal letter or the boxes above to:**

- The address associated with the above-mentioned Customer Number
- OR**
- The address associated with Customer Number:
- OR**

<input type="checkbox"/> Firm or Individual Name			
Address			
City	State	Zip	
Country			
Telephone	Email		

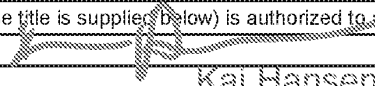
I am the Applicant (if the Applicant is a juristic entity, list the Applicant name in the box):

XR Communications, LLC d/b/a Vivato Technologies

- Inventor or Joint Inventor (title not required below)
- Legal Representative of a Deceased or Legally Incapacitated Inventor (title not required below)
- Assignee or Person to Whom the Inventor is Under an Obligation to Assign (provide signer's title if applicant is a juristic entity)
- Person Who Otherwise Shows Sufficient Proprietary Interest (e.g., a petition under 37 CFR 1.46(b)(2) was granted in the application or is concurrently being filed with this document) (provide signer's title if applicant is a juristic entity)

**SIGNATURE of Applicant for Patent**

The undersigned (whose title is supplied below) is authorized to act on behalf of the applicant (e.g., where the applicant is a juristic entity).

Signature		Date (Optional)	September 12th, 2017
Name	Kai Hansen		
Title	Managing Member		

**NOTE:** Signature - This form must be signed by the applicant in accordance with 37 CFR 1.33. See 37 CFR 1.4 for signature requirements and certifications. If more than one applicant, use multiple forms.

Total of **1** forms are submitted.

This collection of information is required by 37 CFR 1.131, 1.32, and 1.33. The information is required to obtain or retain a benefit by the public which is to file (and by the USPTO to process) an application. Confidentiality is governed by 35 U.S.C. 122 and 37 CFR 1.11 and 1.14. This collection is estimated to take 3 minutes to complete, including gathering, preparing, and submitting the completed application form to the USPTO. Time will vary depending upon the individual case. Any comments on the amount of time you require to complete this form and/or suggestions for reducing this burden, should be sent to the Chief Information Officer, U.S. Patent and Trademark Office, U.S. Department of Commerce, P.O. Box 1450, Alexandria, VA 22313-1450. DO NOT SEND FEES OR COMPLETED FORMS TO THIS ADDRESS. SEND TO: Commissioner for Patents, P.O. Box 1450, Alexandria, VA 22313-1450.

*If you need assistance in completing the form, call 1-800-PTO-9199 and select option 2.*

## Electronic Acknowledgement Receipt

<b>EFS ID:</b>	30395850
<b>Application Number:</b>	15495539
<b>International Application Number:</b>	
<b>Confirmation Number:</b>	1050
<b>Title of Invention:</b>	DIRECTED WIRELESS COMMUNICATION
<b>First Named Inventor/Applicant Name:</b>	Marcus Da Silva
<b>Customer Number:</b>	114581
<b>Filer:</b>	Vladislav Z. Teplitskiy/Danika Gregory
<b>Filer Authorized By:</b>	Vladislav Z. Teplitskiy
<b>Attorney Docket Number:</b>	E1027.800(T).US1D1C1C3
<b>Receipt Date:</b>	18-SEP-2017
<b>Filing Date:</b>	24-APR-2017
<b>Time Stamp:</b>	16:02:55
<b>Application Type:</b>	Utility under 35 USC 111(a)

### Payment information:

Submitted with Payment	no
------------------------	----

### File Listing:

Document Number	Document Description	File Name	File Size(Bytes)/ Message Digest	Multi Part /.zip	Pages (if appl.)
1	Power of Attorney	2017-09-18POA_with_transmit tal-XRCOM_001C5.pdf	257801  fb0ed60b95d293e67264cb37f003de7ecdb 27fb0	no	2

### Warnings:

<b>Information:</b>	
<b>Total Files Size (in bytes):</b>	257801
<p><b>This Acknowledgement Receipt evidences receipt on the noted date by the USPTO of the indicated documents, characterized by the applicant, and including page counts, where applicable. It serves as evidence of receipt similar to a Post Card, as described in MPEP 503.</b></p> <p><b><u>New Applications Under 35 U.S.C. 111</u></b>  <b>If a new application is being filed and the application includes the necessary components for a filing date (see 37 CFR 1.53(b)-(d) and MPEP 506), a Filing Receipt (37 CFR 1.54) will be issued in due course and the date shown on this Acknowledgement Receipt will establish the filing date of the application.</b></p> <p><b><u>National Stage of an International Application under 35 U.S.C. 371</u></b>  <b>If a timely submission to enter the national stage of an international application is compliant with the conditions of 35 U.S.C. 371 and other applicable requirements a Form PCT/DO/EO/903 indicating acceptance of the application as a national stage submission under 35 U.S.C. 371 will be issued in addition to the Filing Receipt, in due course.</b></p> <p><b><u>New International Application Filed with the USPTO as a Receiving Office</u></b>  <b>If a new international application is being filed and the international application includes the necessary components for an international filing date (see PCT Article 11 and MPEP 1810), a Notification of the International Application Number and of the International Filing Date (Form PCT/RO/105) will be issued in due course, subject to prescriptions concerning national security, and the date shown on this Acknowledgement Receipt will establish the international filing date of the application.</b></p>	



UNITED STATES PATENT AND TRADEMARK OFFICE

UNITED STATES DEPARTMENT OF COMMERCE
United States Patent and Trademark Office
Address: COMMISSIONER FOR PATENTS
P.O. Box 1450
Alexandria, Virginia 22313-1450
www.uspto.gov

Table with 4 columns: APPLICATION NUMBER (15/495,539), FILING OR 371(C) DATE (04/24/2017), FIRST NAMED APPLICANT (Marcus Da Silva), ATTY. DOCKET NO./TITLE (E1027.800(T).US1D1C1C3)

CONFIRMATION NO. 1050

114581
EIP US LLP
2468 Historic Decatur Road
Suite 200
San Diego, CA 92106

PUBLICATION NOTICE



Title:DIRECTED WIRELESS COMMUNICATION

Publication No.US-2017-0230094-A1

Publication Date:08/10/2017

NOTICE OF PUBLICATION OF APPLICATION

The above-identified application will be electronically published as a patent application publication pursuant to 37 CFR 1.211, et seq. The patent application publication number and publication date are set forth above.

The publication may be accessed through the USPTO's publically available Searchable Databases via the Internet at www.uspto.gov. The direct link to access the publication is currently http://www.uspto.gov/patft/.

The publication process established by the Office does not provide for mailing a copy of the publication to applicant. A copy of the publication may be obtained from the Office upon payment of the appropriate fee set forth in 37 CFR 1.19(a)(1). Orders for copies of patent application publications are handled by the USPTO's Public Records Division. The Public Records Division can be reached by telephone at (571) 272-3150 or (800) 972-6382, by facsimile at (571) 273-3250, by mail addressed to the United States Patent and Trademark Office, Public Records Division, Alexandria, VA 22313-1450 or via the Internet.

In addition, information on the status of the application, including the mailing date of Office actions and the dates of receipt of correspondence filed in the Office, may also be accessed via the Internet through the Patent Electronic Business Center at www.uspto.gov using the public side of the Patent Application Information and Retrieval (PAIR) system. The direct link to access this status information is currently https://portal.uspto.gov/pair/PublicPair. Prior to publication, such status information is confidential and may only be obtained by applicant using the private side of PAIR.

Further assistance in electronically accessing the publication, or about PAIR, is available by calling the Patent Electronic Business Center at 1-866-217-9197.

Office of Data Management, Application Assistance Unit (571) 272-4000, or (571) 272-4200, or 1-888-786-0101

<b>INFORMATION DISCLOSURE STATEMENT BY APPLICANT</b> ( Not for submission under 37 CFR 1.99)	Application Number	15495539
	Filing Date	2017-04-24
	First Named Inventor	Marcus DA SILVA
	Art Unit	2631
	Examiner Name	Gina M. MCKIE
	Attorney Docket Number	E1027.800(T).US1D1C1C3

U.S.PATENTS							Remove
Examiner Initial*	Cite No	Patent Number	Kind Code <sup>1</sup>	Issue Date	Name of Patentee or Applicant of cited Document	Pages,Columns,Lines where Relevant Passages or Relevant Figures Appear	
	1	5933421	A	1999-08-03	ALAMOUTI et al		
	2	8412106	B2	2013-04-02	DA SILVA et al.		

If you wish to add additional U.S. Patent citation information please click the Add button. Add

U.S.PATENT APPLICATION PUBLICATIONS							Remove
Examiner Initial*	Cite No	Publication Number	Kind Code <sup>1</sup>	Publication Date	Name of Patentee or Applicant of cited Document	Pages,Columns,Lines where Relevant Passages or Relevant Figures Appear	
	1	20040014429	A1	2004-01-22	GUO		
	2	20010003443	A1	2001-06-14	VELAZQUEZ		

If you wish to add additional U.S. Published Application citation information please click the Add button. Add

FOREIGN PATENT DOCUMENTS								Remove
Examiner Initial*	Cite No	Foreign Document Number <sup>3</sup>	Country Code <sup>2</sup>	Kind Code <sup>4</sup>	Publication Date	Name of Patentee or Applicant of cited Document	Pages,Columns,Lines where Relevant Passages or Relevant Figures Appear	T <sup>5</sup>
	1							



<b>INFORMATION DISCLOSURE STATEMENT BY APPLICANT</b> ( Not for submission under 37 CFR 1.99)	Application Number	15495539
	Filing Date	2017-04-24
	First Named Inventor	Marcus DA SILVA
	Art Unit	2631
	Examiner Name	Gina M. MCKIE
	Attorney Docket Number	E1027.800(T).US1D1C1C3

If you wish to add additional Foreign Patent Document citation information please click the Add button

**NON-PATENT LITERATURE DOCUMENTS**

Examiner Initials*	Cite No	Include name of the author (in CAPITAL LETTERS), title of the article (when appropriate), title of the item (book, magazine, journal, serial, symposium, catalog, etc), date, pages(s), volume-issue number(s), publisher, city and/or country where published.	T <sup>5</sup>
	1		

If you wish to add additional non-patent literature document citation information please click the Add button

**EXAMINER SIGNATURE**

Examiner Signature	<input type="text"/>	Date Considered	<input type="text"/>
--------------------	----------------------	-----------------	----------------------

\*EXAMINER: Initial if reference considered, whether or not citation is in conformance with MPEP 609. Draw line through a citation if not in conformance and not considered. Include copy of this form with next communication to applicant.

<sup>1</sup> See Kind Codes of USPTO Patent Documents at [www.USPTO.GOV](http://www.USPTO.GOV) or MPEP 901.04. <sup>2</sup> Enter office that issued the document, by the two-letter code (WIPO Standard ST.3). <sup>3</sup> For Japanese patent documents, the indication of the year of the reign of the Emperor must precede the serial number of the patent document. <sup>4</sup> Kind of document by the appropriate symbols as indicated on the document under WIPO Standard ST.16 if possible. <sup>5</sup> Applicant is to place a check mark here if English language translation is attached.

<b>INFORMATION DISCLOSURE STATEMENT BY APPLICANT</b> ( Not for submission under 37 CFR 1.99)	Application Number	15495539
	Filing Date	2017-04-24
	First Named Inventor	Marcus DA SILVA
	Art Unit	2631
	Examiner Name	Gina M. MCKIE
	Attorney Docket Number	E1027.800(T).US1D1C1C3

**CERTIFICATION STATEMENT**

Please see 37 CFR 1.97 and 1.98 to make the appropriate selection(s):

That each item of information contained in the information disclosure statement was first cited in any communication from a foreign patent office in a counterpart foreign application not more than three months prior to the filing of the information disclosure statement. See 37 CFR 1.97(e)(1).

**OR**

That no item of information contained in the information disclosure statement was cited in a communication from a foreign patent office in a counterpart foreign application, and, to the knowledge of the person signing the certification after making reasonable inquiry, no item of information contained in the information disclosure statement was known to any individual designated in 37 CFR 1.56(c) more than three months prior to the filing of the information disclosure statement. See 37 CFR 1.97(e)(2).

See attached certification statement.

The fee set forth in 37 CFR 1.17 (p) has been submitted herewith.

A certification statement is not submitted herewith.

**SIGNATURE**

A signature of the applicant or representative is required in accordance with CFR 1.33, 10.18. Please see CFR 1.4(d) for the form of the signature.

Signature	/Nicholas R. Transier/	Date (YYYY-MM-DD)	2017-07-07
Name/Print	Nicholas R. TRANSIER	Registration Number	68743

This collection of information is required by 37 CFR 1.97 and 1.98. The information is required to obtain or retain a benefit by the public which is to file (and by the USPTO to process) an application. Confidentiality is governed by 35 U.S.C. 122 and 37 CFR 1.14. This collection is estimated to take 1 hour to complete, including gathering, preparing and submitting the completed application form to the USPTO. Time will vary depending upon the individual case. Any comments on the amount of time you require to complete this form and/or suggestions for reducing this burden, should be sent to the Chief Information Officer, U.S. Patent and Trademark Office, U.S. Department of Commerce, P.O. Box 1450, Alexandria, VA 22313-1450. **DO NOT SEND FEES OR COMPLETED FORMS TO THIS ADDRESS. SEND TO: Commissioner for Patents, P.O. Box 1450, Alexandria, VA 22313-1450.**

## Privacy Act Statement

The Privacy Act of 1974 (P.L. 93-579) requires that you be given certain information in connection with your submission of the attached form related to a patent application or patent. Accordingly, pursuant to the requirements of the Act, please be advised that: (1) the general authority for the collection of this information is 35 U.S.C. 2(b)(2); (2) furnishing of the information solicited is voluntary; and (3) the principal purpose for which the information is used by the U.S. Patent and Trademark Office is to process and/or examine your submission related to a patent application or patent. If you do not furnish the requested information, the U.S. Patent and Trademark Office may not be able to process and/or examine your submission, which may result in termination of proceedings or abandonment of the application or expiration of the patent.

The information provided by you in this form will be subject to the following routine uses:

1. The information on this form will be treated confidentially to the extent allowed under the Freedom of Information Act (5 U.S.C. 552) and the Privacy Act (5 U.S.C. 552a). Records from this system of records may be disclosed to the Department of Justice to determine whether the Freedom of Information Act requires disclosure of these records.
2. A record from this system of records may be disclosed, as a routine use, in the course of presenting evidence to a court, magistrate, or administrative tribunal, including disclosures to opposing counsel in the course of settlement negotiations.
3. A record in this system of records may be disclosed, as a routine use, to a Member of Congress submitting a request involving an individual, to whom the record pertains, when the individual has requested assistance from the Member with respect to the subject matter of the record.
4. A record in this system of records may be disclosed, as a routine use, to a contractor of the Agency having need for the information in order to perform a contract. Recipients of information shall be required to comply with the requirements of the Privacy Act of 1974, as amended, pursuant to 5 U.S.C. 552a(m).
5. A record related to an International Application filed under the Patent Cooperation Treaty in this system of records may be disclosed, as a routine use, to the International Bureau of the World Intellectual Property Organization, pursuant to the Patent Cooperation Treaty.
6. A record in this system of records may be disclosed, as a routine use, to another federal agency for purposes of National Security review (35 U.S.C. 181) and for review pursuant to the Atomic Energy Act (42 U.S.C. 218(c)).
7. A record from this system of records may be disclosed, as a routine use, to the Administrator, General Services, or his/her designee, during an inspection of records conducted by GSA as part of that agency's responsibility to recommend improvements in records management practices and programs, under authority of 44 U.S.C. 2904 and 2906. Such disclosure shall be made in accordance with the GSA regulations governing inspection of records for this purpose, and any other relevant (i.e., GSA or Commerce) directive. Such disclosure shall not be used to make determinations about individuals.
8. A record from this system of records may be disclosed, as a routine use, to the public after either publication of the application pursuant to 35 U.S.C. 122(b) or issuance of a patent pursuant to 35 U.S.C. 151. Further, a record may be disclosed, subject to the limitations of 37 CFR 1.14, as a routine use, to the public if the record was filed in an application which became abandoned or in which the proceedings were terminated and which application is referenced by either a published application, an application open to public inspections or an issued patent.
9. A record from this system of records may be disclosed, as a routine use, to a Federal, State, or local law enforcement agency, if the USPTO becomes aware of a violation or potential violation of law or regulation.

## Electronic Acknowledgement Receipt

<b>EFS ID:</b>	29719972
<b>Application Number:</b>	15495539
<b>International Application Number:</b>	
<b>Confirmation Number:</b>	1050
<b>Title of Invention:</b>	DIRECTED WIRELESS COMMUNICATION
<b>First Named Inventor/Applicant Name:</b>	Marcus Da Silva
<b>Customer Number:</b>	114581
<b>Filer:</b>	Nicholas R. Transier/Jenny Stedman
<b>Filer Authorized By:</b>	Nicholas R. Transier
<b>Attorney Docket Number:</b>	E1027.800(T).US1D1C1C3
<b>Receipt Date:</b>	07-JUL-2017
<b>Filing Date:</b>	24-APR-2017
<b>Time Stamp:</b>	18:05:51
<b>Application Type:</b>	Utility under 35 USC 111(a)

### Payment information:

Submitted with Payment	no
------------------------	----

### File Listing:

Document Number	Document Description	File Name	File Size(Bytes)/ Message Digest	Multi Part /.zip	Pages (if appl.)
1	Information Disclosure Statement (IDS) Form (SB08)	2017-07-07_IDS_E1027_800T_US1D1C1C3.pdf	1035123 1f3db6c94c3fb1daf1c4e64d2990602fd7487b	no	4

### Warnings:

<b>Information:</b>	
<b>Total Files Size (in bytes):</b>	1035123
<p><b>This Acknowledgement Receipt evidences receipt on the noted date by the USPTO of the indicated documents, characterized by the applicant, and including page counts, where applicable. It serves as evidence of receipt similar to a Post Card, as described in MPEP 503.</b></p> <p><b><u>New Applications Under 35 U.S.C. 111</u></b>  <b>If a new application is being filed and the application includes the necessary components for a filing date (see 37 CFR 1.53(b)-(d) and MPEP 506), a Filing Receipt (37 CFR 1.54) will be issued in due course and the date shown on this Acknowledgement Receipt will establish the filing date of the application.</b></p> <p><b><u>National Stage of an International Application under 35 U.S.C. 371</u></b>  <b>If a timely submission to enter the national stage of an international application is compliant with the conditions of 35 U.S.C. 371 and other applicable requirements a Form PCT/DO/EO/903 indicating acceptance of the application as a national stage submission under 35 U.S.C. 371 will be issued in addition to the Filing Receipt, in due course.</b></p> <p><b><u>New International Application Filed with the USPTO as a Receiving Office</u></b>  <b>If a new international application is being filed and the international application includes the necessary components for an international filing date (see PCT Article 11 and MPEP 1810), a Notification of the International Application Number and of the International Filing Date (Form PCT/RO/105) will be issued in due course, subject to prescriptions concerning national security, and the date shown on this Acknowledgement Receipt will establish the international filing date of the application.</b></p>	



UNITED STATES PATENT AND TRADEMARK OFFICE

UNITED STATES DEPARTMENT OF COMMERCE
United States Patent and Trademark Office
Address: COMMISSIONER FOR PATENTS
P. O. Box 1450
Alexandria, Virginia 22313-1450
www.uspto.gov

Table with columns: APPLICATION NO., FILING DATE, FIRST NAMED INVENTOR, ATTORNEY DOCKET NO., CONFIRMATION NO., EXAMINER, ART UNIT, PAPER NUMBER, NOTIFICATION DATE, DELIVERY MODE. Includes application details for 15/495,539 and 114581.

Please find below and/or attached an Office communication concerning this application or proceeding.

The time period for reply, if any, is set in the attached communication.

Notice of the Office communication was sent electronically on above-indicated "Notification Date" to the following e-mail address(es):

sandiego@eip.com

<b>Office Action Summary</b>	<b>Application No.</b> 15/495,539	<b>Applicant(s)</b> DA SILVA ET AL.	
	<b>Examiner</b> GINA MCKIE	<b>Art Unit</b> 2631	<b>AIA (First Inventor to File) Status</b> No

**-- The MAILING DATE of this communication appears on the cover sheet with the correspondence address --**

**Period for Reply**

A SHORTENED STATUTORY PERIOD FOR REPLY IS SET TO EXPIRE 3 MONTHS FROM THE MAILING DATE OF THIS COMMUNICATION.

- Extensions of time may be available under the provisions of 37 CFR 1.136(a). In no event, however, may a reply be timely filed after SIX (6) MONTHS from the mailing date of this communication.
- If NO period for reply is specified above, the maximum statutory period will apply and will expire SIX (6) MONTHS from the mailing date of this communication.
- Failure to reply within the set or extended period for reply will, by statute, cause the application to become ABANDONED (35 U.S.C. § 133). Any reply received by the Office later than three months after the mailing date of this communication, even if timely filed, may reduce any earned patent term adjustment. See 37 CFR 1.704(b).

**Status**

- 1)  Responsive to communication(s) filed on 19 June 2017.  
 A declaration(s)/affidavit(s) under **37 CFR 1.130(b)** was/were filed on \_\_\_\_\_.
- 2a)  This action is **FINAL**.                      2b)  This action is non-final.
- 3)  An election was made by the applicant in response to a restriction requirement set forth during the interview on \_\_\_\_\_; the restriction requirement and election have been incorporated into this action.
- 4)  Since this application is in condition for allowance except for formal matters, prosecution as to the merits is closed in accordance with the practice under *Ex parte Quayle*, 1935 C.D. 11, 453 O.G. 213.

**Disposition of Claims\***

- 5)  Claim(s) 1-20 is/are pending in the application.  
5a) Of the above claim(s) \_\_\_\_\_ is/are withdrawn from consideration.
- 6)  Claim(s) \_\_\_\_\_ is/are allowed.
- 7)  Claim(s) 1-20 is/are rejected.
- 8)  Claim(s) \_\_\_\_\_ is/are objected to.
- 9)  Claim(s) \_\_\_\_\_ are subject to restriction and/or election requirement.

\* If any claims have been determined allowable, you may be eligible to benefit from the **Patent Prosecution Highway** program at a participating intellectual property office for the corresponding application. For more information, please see [http://www.uspto.gov/patents/init\\_events/pph/index.jsp](http://www.uspto.gov/patents/init_events/pph/index.jsp) or send an inquiry to [PPHfeedback@uspto.gov](mailto:PPHfeedback@uspto.gov).

**Application Papers**

- 10)  The specification is objected to by the Examiner.
- 11)  The drawing(s) filed on 24 April 2017 is/are: a)  accepted or b)  objected to by the Examiner.  
Applicant may not request that any objection to the drawing(s) be held in abeyance. See 37 CFR 1.85(a).  
Replacement drawing sheet(s) including the correction is required if the drawing(s) is objected to. See 37 CFR 1.121(d).

**Priority under 35 U.S.C. § 119**

- 12)  Acknowledgment is made of a claim for foreign priority under 35 U.S.C. § 119(a)-(d) or (f).

**Certified copies:**

- a)  All    b)  Some\*\*    c)  None of the:
1.  Certified copies of the priority documents have been received.
  2.  Certified copies of the priority documents have been received in Application No. \_\_\_\_\_.
  3.  Copies of the certified copies of the priority documents have been received in this National Stage application from the International Bureau (PCT Rule 17.2(a)).

\*\* See the attached detailed Office action for a list of the certified copies not received.

**Attachment(s)**

- 1)  Notice of References Cited (PTO-892)
- 2)  Information Disclosure Statement(s) (PTO/SB/08a and/or PTO/SB/08b)  
Paper No(s)/Mail Date \_\_\_\_\_.
- 3)  Interview Summary (PTO-413)  
Paper No(s)/Mail Date. \_\_\_\_\_.
- 4)  Other: \_\_\_\_\_.

**DETAILED ACTION**

***Notice of Pre-AIA or AIA Status***

1. The present application is being examined under the pre-AIA first to invent provisions.

***Claim Rejections - 35 USC § 103***

2. The following is a quotation of pre-AIA 35 U.S.C. 103(a) which forms the basis for all obviousness rejections set forth in this Office action:

(a) A patent may not be obtained though the invention is not identically disclosed or described as set forth in section 102, if the differences between the subject matter sought to be patented and the prior art are such that the subject matter as a whole would have been obvious at the time the invention was made to a person having ordinary skill in the art to which said subject matter pertains. Patentability shall not be negated by the manner in which the invention was made.

3. The factual inquiries set forth in *Graham v. John Deere Co.*, 383 U.S. 1, 148 USPQ 459 (1966), that are applied for establishing a background for determining obviousness under pre-AIA 35 U.S.C. 103(a) are summarized as follows:

1. Determining the scope and contents of the prior art.
2. Ascertaining the differences between the prior art and the claims at issue.
3. Resolving the level of ordinary skill in the pertinent art.
4. Considering objective evidence present in the application indicating obviousness or nonobviousness.

4. Claims 1-20 is/are rejected under pre-AIA 35 U.S.C. 103(a) as being unpatentable over Crilly, Jr. et al. (US 2002/0158801 A1) in view of Ishii et al. (US 6,714,584).

**Regarding claim 1,**



As shown in FIGS. 1-24, Crilly discloses a receiver for use in a wireless communications system, the receiver comprising:

- an antenna (**see Crilly, FIG. 4, antenna array 110**);
- a transceiver operatively coupled to the antenna and configured to transmit and receive electromagnetic signals using the antenna (**see Crilly, FIG. 2, transmitter/receiver 114**); and
- a processor operatively coupled to the transceiver, (**see Crilly, FIG. 4, control logic 112**) the processor configured to:
  - receive a first signal transmission from a remote station via the antenna and a second signal transmission via the antenna (**see Crilly FIG. 4, paragraph [0091]; These signals, both desired and undesired, are collected by receiving elements within antenna array 110 and are eventually provided to control logic 110.**);
  - determine first signal information for the first signal transmission (**see Crilly, paragraph [0092]; Here, control logic 112 includes a search receiver 164 that is configured to update routing information 120 with regard to the received signals.**);
  - determine second signal information for the second signal transmission, wherein the second signal information is different than the first signal information (**see Crilly, paragraph [0092]; Here, control logic 112 includes a search receiver 164 that is configured to update routing information 120 with regard to the received signals.**);

- determine a set of weighting values based on the first signal information and the second signal information, wherein the set of weighting values is configured to be used by the remote station to construct one or more beam-formed transmission signals (see Crilly, paragraph [0093]; The stored **weighting** values associated with each connection/source are utilized in a **weighting** matrix 166. **Weighting** matrix 166 operates so as to apply the latest **weighting** values to the received signals and also to transmitted signals. In this illustrative example, subsequently received signals will be processed using the most recent **weighting** values in the **weighting** matrix.); and
- cause the transceiver to generate a third signal comprising content based on the set of weighting values (see Crilly, paragraph [0093]; The stored **weighting** values associated with each connection/source are utilized in a **weighting** matrix 166. **Weighting** matrix 166 operates so as to apply the latest **weighting** values to the received signals and also to transmitted signals. In this illustrative example, subsequently received signals will be processed using the most recent **weighting** values in the **weighting** matrix.)

Crilly does not specifically disclose “receive a first signal transmission from a remote station via the antenna and a second signal transmission from the remote station via the antenna simultaneously.”

However, Ishii in the same field of endeavor discloses receiving a first signal transmission from a remote station via the antenna and a second signal transmission from the remote station via the antenna simultaneously (**see Ishii, col. 3, lines 9-30; “Signals received at different directional antennas 1-1 to 1-N are introduced into delay circuits 2-2 to 2-M. A directivity in a direction, for example, at every equal angle (360/N degrees) is assigned to each of antennas 1-1 to 1-N, respectively. Delay circuit 2-1 has a time delay of 0 and thus is omitted in the drawings. Delay circuits 2-2 to 2-M adaptively delay the received signals so that receivers 3-1 to 3-M may receive simultaneously the desired signal components incoming at different timings.”**).

It would have been obvious to one of ordinary skill in the art at the time the present invention was made to modify the invention of Crilly as taught by Ishii and receive a first signal transmission from a remote station via the antenna and a second signal transmission from the remote station via the antenna simultaneously.

***Rationale: Applying a known technique to a known device (method, or product) ready for improvement to yield predictable results***

To reject a claim based on this rationale, Office personnel must resolve the Graham factual inquiries. Then, Office personnel must articulate the following:

(1) a finding that the prior art contained a “base” device (method, or product) upon which the claimed invention can be seen as an “improvement;”

(2) a finding that the prior art contained a known technique that is applicable to the base device (method, or product);

(3) a finding that one of ordinary skill in the art would have recognized that applying the known technique would have yielded predictable results and resulted in an improved system; and

(4) whatever additional findings based on the Graham factual inquiries may be necessary, in view of the facts of the case under consideration, to explain a conclusion of obviousness. (MPEP § 2143).

In this case:

Crilly contains a "base" device of a receiver for use in a wireless communications system which the claimed invention can be seen as an "improvement" in that receiving a first signal transmission from a remote station via the antenna and a second signal transmission from the remote station via the antenna simultaneously.

Ishii contains known technique of a first signal transmission from a remote station via the antenna and a second signal transmission from the remote station via the antenna simultaneously that is applicable to the "base" device.

Ishii's known technique a first signal transmission from a remote station via the antenna and a second signal transmission from the remote station via the antenna simultaneously would have been recognized by one of ordinary skill in the art as applicable to the "base" process of Crilly and the results would have been predictable and resulted in a receiver for use in a wireless communications system receiving a first

signal transmission from a remote station via the antenna and a second signal transmission from the remote station via the antenna simultaneously which results in an improved process.

Therefore, the claimed subject matter would have been obvious to a person having ordinary skill in the art at the time the invention was made.

**Regarding claim 2,**

The combination of Crilly and Ishii discloses the receiver as recited in Claim 1, wherein the antenna comprises a first antenna element and a second antenna element, and wherein the processor is further configured to:

receive the first signal transmission from the remote station via the first antenna element and the second signal transmission for the remote station via the second antenna element simultaneously (**see Crilly FIG. 4, paragraph [0091]; These signals, both desired and undesired, are collected by receiving elements within antenna array 110 and are eventually provided to control logic 110.**); and

cause the transceiver to transmit the third signal to the remote station via the antenna (**see Crilly, paragraph [0093]; Weighting matrix 166 operates so as to apply the latest weighting values to the received signals and also to transmitted signals.**)

**Regarding claim 3,**

The combination of Crilly and Ishii discloses the receiver as recited in Claim 1, wherein the first signal transmission and the second signal transmission comprise electromagnetic signals comprising one or more transmission peaks and one or more transmission nulls (see Crilly, paragraph [0010]; **“The logic is operatively coupled to the antenna array and configured to selectively control the placement of the transmission peaks and transmission nulls within the outgoing multi-beam electromagnetic signals.”**).

**Regarding claim 4,**

The combination of Crilly and Ishii discloses the receiver as recited in Claim 1, wherein the first signal transmission and the second signal transmission are directional transmissions (see Crilly, paragraph [0009]; **In certain further implementations, the adaptive antenna is also configured to selectively receive at least one incoming electromagnetic signal directed through the coverage area.**).

**Regarding claim 5,**

The combination of Crilly and Ishii discloses the receiver as recited in Claim 1, wherein the set of weighting values is further based on one or more of: a transmit power level, a data transmit rate, an antenna direction, quality of service data, or timing data (see Crilly, paragraph [0011], **“By way of example, the routing information may include transmit power level information, transmit data rate information, antenna**

**pointing direction information, weighting information, constraints information, transmission null location information, transmission peak location information, Quality of Service (QoS) information, priority information, data packet lifetime information, frequency information, timing information, and/or keep out area information.”).**

**Regarding claim 6,**

The combination of Crilly and Ishii discloses the receiver as recited in Claim 1, wherein the content comprises data configured to be used by the remote station to modify the placement of one or more transmission peaks and one or more transmission nulls in a subsequent signal transmission (**see Crilly, paragraph [0057]; “...part of a wireless routing device and configured to produce a transmission pattern that selectively places transmission nulls and/or peaks in certain directions within an applicable coverage area.”)**)

**Regarding claim 7,**

The combination of Crilly and Ishii discloses the receiver as recited in Claim 1, wherein the processor is further configured to:

determine a plurality of signal strength indications for the first signal transmission; determine a first signal strength average based on the plurality of signal strength indications for the first signal transmission; determine a plurality of signal strength indications for the second signal transmission; determine a second signal

strength average based on the plurality of signal strength indications for the second signal transmission (**see Crilly, paragraph [0012]; “All or part of this routing information may be stored in one or more routing tables. The routing table(s) may further include routing information such as, e.g., IP address information, MAC address information, protocol identifying information, modulation method identifying information, Connection ID (CID) information, node directional information, node transmit power level information, node received signal strength indicator (RSSI) level information, transmit channel information, backup transmit channel information, receive channel information, backup receive channel information, transmission data rate information, receive data rate information, and interference nulling information.”**); and

cause the transceiver to generate a fourth signal based on the first signal strength average and the second signal strength average (**see Crilly, paragraph [0016]; “The scheduler can establish one or more traffic schedules by determining at least one assignment for an outgoing data transmission.”**).

**Regarding claim 8,**

The combination of Crilly and Ishii discloses the receiver as recited in Claim 7, wherein the processor is further configured to: cause the transceiver to transmit the fourth signal to the remote station via the smart antenna (**see Crilly, paragraph [0016]; “The scheduler can establish one or more traffic schedules by determining at least one assignment for an outgoing data transmission.”**).



**Regarding claim 9,**

As shown in FIGS. 1-24, Crilly discloses a method in a wireless communications system, the method comprising:

- receiving a first signal transmission from a remote station via a first antenna element of an antenna and a second signal transmission via a second antenna element of the antenna (**see Crilly, FIG. 4, antenna array 110**);
- determining first signal information for the first signal transmission (**see Crilly FIG. 4, paragraph [0091]; These signals, both desired and undesired, are collected by receiving elements within antenna array 110 and are eventually provided to control logic 110.**);
- determining second signal information for the second signal transmission, wherein the second signal information is different than the first signal information (**see Crilly FIG. 4, paragraph [0091]; These signals, both desired and undesired, are collected by receiving elements within antenna array 110 and are eventually provided to control logic 110.**);
- determining a set of weighting values based on the first signal information and the second signal information, wherein the set of weighting values is configured to be used by the remote station to construct one or more beam-formed transmission signals (**see Crilly, paragraph [0093]; The stored weighting values associated with each connection/source are utilized in a weighting matrix 166. Weighting matrix 166 operates so as to apply the latest weighting values to the received**

**signals and also to transmitted signals. In this illustrative example, subsequently received signals will be processed using the most recent weighting values in the weighting matrix.); and**

- transmitting to the remote station a third signal comprising content based on the set of weighting values (see Crilly, paragraph [0093]; The stored weighting values associated with each connection/source are utilized in a weighting matrix 166. Weighting matrix 166 operates so as to apply the latest weighting values to the received signals and also to transmitted signals. In this illustrative example, subsequently received signals will be processed using the most recent weighting values in the weighting matrix.).

Crilly does not specifically disclose “receive a first signal transmission from a remote station via the antenna and a second signal transmission from the remote station via the antenna simultaneously.”

However, Ishii in the same field of endeavor discloses receiving a first signal transmission from a remote station via the antenna and a second signal transmission from the remote station via the antenna simultaneously (see Ishii, col. 3, lines 9-30; “Signals received at different directional antennas 1-1 to 1-N are introduced into delay circuits 2-2 to 2-M. A directivity in a direction, for example, at every equal angle (360/N degrees) is assigned to each of antennas 1-1 to 1-N, respectively. Delay circuit 2-1 has a time delay of 0 and thus is omitted in the drawings. Delay circuits 2-2 to 2-M adaptively delay the received signals so that receivers 3-1 to 3-

**M may receive simultaneously the desired signal components incoming at different timings.”).**

It would have been obvious to one of ordinary skill in the art at the time the present invention was made to modify the invention of Crilly as taught by Ishii and receive a first signal transmission from a remote station via the antenna and a second signal transmission from the remote station via the antenna simultaneously.

***Rationale: Applying a known technique to a known device (method, or product) ready for improvement to yield predictable results***

To reject a claim based on this rationale, Office personnel must resolve the Graham factual inquiries. Then, Office personnel must articulate the following:

- (1) a finding that the prior art contained a “base” device (method, or product) upon which the claimed invention can be seen as an “improvement;”
- (2) a finding that the prior art contained a known technique that is applicable to the base device (method, or product);
- (3) a finding that one of ordinary skill in the art would have recognized that applying the known technique would have yielded predictable results and resulted in an improved system; and
- (4) whatever additional findings based on the Graham factual inquiries may be necessary, in view of the facts of the case under consideration, to explain a conclusion of obviousness. (MPEP § 2143).

In this case:

Crilly contains a "base" device of a receiver for use in a wireless communications system which the claimed invention can be seen as an "improvement" in that receiving a first signal transmission from a remote station via the antenna and a second signal transmission from the remote station via the antenna simultaneously.

Ishii contains known technique of a first signal transmission from a remote station via the antenna and a second signal transmission from the remote station via the antenna simultaneously that is applicable to the "base" device.

Ishii's known technique a first signal transmission from a remote station via the antenna and a second signal transmission from the remote station via the antenna simultaneously would have been recognized by one of ordinary skill in the art as applicable to the "base" process of Crilly and the results would have been predictable and resulted in a receiver for use in a wireless communications system receiving a first signal transmission from a remote station via the antenna and a second signal transmission from the remote station via the antenna simultaneously which results in an improved process.

Therefore, the claimed subject matter would have been obvious to a person having ordinary skill in the art at the time the invention was made.

**Regarding claim 10,**

The combination of Crilly and Ishii discloses the method as recited in Claim 9, further comprising: transmitting the third signal to the remote station via the antenna (see Crilly, paragraph [0016]; **“The scheduler can establish one or more traffic schedules by determining at least one assignment for an outgoing data transmission.”**).

**Regarding claim 11,**

The combination of Crilly and Ishii discloses the method as recited in Claim 9, wherein the first signal transmission and the second signal transmission comprise electromagnetic signals comprising one or more transmission peaks and one or more transmission nulls (see Crilly, paragraph [0010]; **“The logic is operatively coupled to the antenna array and configured to selectively control the placement of the transmission peaks and transmission nulls within the outgoing multi-beam electromagnetic signals.”**).

**Regarding claim 12,**

The combination of Crilly and Ishii discloses the method as recited in Claim 9, wherein the first signal transmission and the second signal transmission are directional transmissions (see Crilly, paragraph [0009]; **In certain further implementations, the adaptive antenna is also configured to selectively receive at least one incoming electromagnetic signal directed through the coverage area.**).

**Regarding claim 13,**

The combination of Crilly and Ishii discloses the method as recited in Claim 9, wherein the set of weighting values is further based on one or more of: a transmit power level, a data transmit rate, an antenna direction, quality of service data, or timing data (see Crilly, paragraph [0011], “By way of example, the routing information may include transmit power level information, transmit data rate information, antenna pointing direction information, weighting information, constraints information, transmission null location information, transmission peak location information, Quality of Service (QoS) information, priority information, data packet lifetime information, frequency information, timing information, and/or keep out area information.”).

**Regarding claim 14,**

The combination of Crilly and Ishii discloses the method as recited in Claim 9, wherein the one or more beam-formed transmission signals comprise data configured to be used by the remote station to modify the placement of one or more transmission peaks and one or more transmission nulls in a subsequent signal transmission (see Crilly, paragraph [0010]; “The logic is operatively coupled to the antenna array and configured to selectively control the placement of the transmission peaks and transmission nulls within the outgoing multi-beam electromagnetic signals.”).

**Regarding claim 15,**

The combination of Crilly and Ishii discloses the method as recited in Claim 9, wherein the processor is further configured to: determining a plurality of signal strength indications for the first signal transmission; determining a first signal strength average based on the plurality of signal strength indications for the first signal transmission; determining a plurality of signal strength indications for the second signal transmission ; determining a second signal strength average based on the plurality of signal strength indications for the second signal transmission; and determining a set of weighting values based on the first signal information and the second signal information, wherein the set of weighting values is configured to construct one or more beam-formed transmission signals (**see Crilly, paragraph [0012]; “All or part of this routing information may be stored in one or more routing tables. The routing table(s) may further include routing information such as, e.g., IP address information, MAC address information, protocol identifying information, modulation method identifying information, Connection ID (CID) information, node directional information, node transmit power level information, node received signal strength indicator (RSSI) level information, transmit channel information, backup transmit channel information, receive channel information, backup receive channel information, transmission data rate information, receive data rate information, and interference nulling information.”**); and

generating the one or more beam-formed transmission signals based on the set of weighting values for transmission to the remote station (**see Crilly, paragraph**

**[0016]; “The scheduler can establish one or more traffic schedules by determining at least one assignment for an outgoing data transmission.”).**

**Regarding claim 16,**

The combination of Crilly and Ishii discloses the method as recited in Claim 15, further comprising: causing the transceiver to transmit the fourth signal to the remote station via the antenna (**see Crilly, paragraph [0016]; “The scheduler can establish one or more traffic schedules by determining at least one assignment for an outgoing data transmission.”**).

**Regarding claim 17,**

As shown in FIGS. 1-24, Crilly discloses an apparatus for use in a wireless communications system, the apparatus comprising:

- an antenna (**see Crilly, FIG. 4, antenna array 110**);
- a transceiver operatively coupled to the antenna (**see Crilly, FIG. 2, transmitter/receiver 114**); and
- a processor operatively coupled to the transceiver (**see Crilly, FIG. 4, control logic 112**), the processor configured to:
  - receive a first signal transmission from a remote station via the antenna, the first signal transmission comprising first signal information (**see Crilly FIG. 4, paragraph [0091]; These signals, both desired and undesired,**



- are collected by receiving elements within antenna array 110 and are eventually provided to control logic 110.);**
- receive a second signal transmission via the antenna, the second signal transmission comprising second signal information (**see Crilly FIG. 4, paragraph [0091]; These signals, both desired and undesired, are collected by receiving elements within antenna array 110 and are eventually provided to control logic 110.);**
  - determine a set of weighting values based on the first signal information and the second signal information, wherein the set of weighting values is configured to be used by the remote station to construct one or more beam-formed transmission signals (**see Crilly, paragraph [0093]; The stored weighting values associated with each connection/source are utilized in a weighting matrix 166. Weighting matrix 166 operates so as to apply the latest weighting values to the received signals and also to transmitted signals. In this illustrative example, subsequently received signals will be processed using the most recent weighting values in the weighting matrix.);**
  - cause the transceiver to generate a third signal comprising content based on the set of weighting values (**see Crilly, paragraph [0093]; The stored weighting values associated with each connection/source are utilized in a weighting matrix 166. Weighting matrix 166 operates so as to apply the latest weighting values to the received signals and**

**also to transmitted signals. In this illustrative example, subsequently received signals will be processed using the most recent weighting values in the weighting matrix.**)

Crilly does not specifically disclose “receive a first signal transmission from a remote station via the antenna and a second signal transmission from the remote station via the antenna.”

However, Ishii in the same field of endeavor discloses receiving a first signal transmission from a remote station via the antenna and a second signal transmission from the remote station via the antenna (**see Ishii, col. 3, lines 9-30; “Signals received at different directional antennas 1-1 to 1-N are introduced into delay circuits 2-2 to 2-M. A directivity in a direction, for example, at every equal angle (360/N degrees) is assigned to each of antennas 1-1 to 1-N, respectively. Delay circuit 2-1 has a time delay of 0 and thus is omitted in the drawings. Delay circuits 2-2 to 2-M adaptively delay the received signals so that receivers 3-1 to 3-M may receive simultaneously the desired signal components incoming at different timings.”**).

It would have been obvious to one of ordinary skill in the art at the time the present invention was made to modify the invention of Crilly as taught by Ishii and receive a first signal transmission from a remote station via the antenna and a second signal transmission from the remote station via the antenna.

***Rationale: Applying a known technique to a known device (method, or product) ready for improvement to yield predictable results***

To reject a claim based on this rationale, Office personnel must resolve the Graham factual inquiries. Then, Office personnel must articulate the following:

(1) a finding that the prior art contained a “base” device (method, or product) upon which the claimed invention can be seen as an “improvement;”

(2) a finding that the prior art contained a known technique that is applicable to the base device (method, or product);

(3) a finding that one of ordinary skill in the art would have recognized that applying the known technique would have yielded predictable results and resulted in an improved system; and

(4) whatever additional findings based on the Graham factual inquiries may be necessary, in view of the facts of the case under consideration, to explain a conclusion of obviousness. (MPEP § 2143).

In this case:

Crilly contains a “base” device of a receiver for use in a wireless communications system which the claimed invention can be seen as an “improvement” in that receiving a first signal transmission from a remote station via the antenna and a second signal transmission from the remote station via the antenna simultaneously.

Ishii contains known technique of a first signal transmission from a remote station via the antenna and a second signal transmission from the remote station via the antenna simultaneously that is applicable to the "base" device.

Ishii's known technique a first signal transmission from a remote station via the antenna and a second signal transmission from the remote station via the antenna simultaneously would have been recognized by one of ordinary skill in the art as applicable to the "base" process of Crilly and the results would have been predictable and resulted in a receiver for use in a wireless communications system receiving a first signal transmission from a remote station via the antenna and a second signal transmission from the remote station via the antenna simultaneously which results in an improved process.

Therefore, the claimed subject matter would have been obvious to a person having ordinary skill in the art at the time the invention was made.

**Regarding claim 18,**

The combination of Crilly and Ishii discloses the apparatus as recited in Claim 17, wherein the first signal transmission and the second signal transmission comprise electromagnetic signals comprising one or more transmission peaks and one or more transmission nulls (**see Crilly, paragraph [0010]; "The logic is operatively coupled to the antenna array and configured to selectively control the placement of the transmission peaks and transmission nulls within the outgoing multi-beam electromagnetic signals."**).

**Regarding claim 19,**

The combination of Crilly and Ishii discloses the apparatus as recited in Claim 17, wherein the first signal information comprises one or more of: a transmit power level, a data transmit rate, an antenna direction, quality of service data, or timing data (**see Crilly, paragraph [0011], “By way of example, the routing information may include transmit power level information, transmit data rate information, antenna pointing direction information, weighting information, constraints information, transmission null location information, transmission peak location information, Quality of Service (QoS) information, priority information, data packet lifetime information, frequency information, timing information, and/or keep out area information.”**).

**Regarding claim 20,**

The combination of Crilly and Ishii discloses the apparatus as recited in Claim 17, wherein the antenna comprises a first antenna element and a second antenna element, and wherein the first antenna element and the second antenna element are directional antenna elements (**see Crilly, paragraph [0009]; In certain further implementations, the adaptive antenna is also configured to selectively receive at least one incoming electromagnetic signal directed through the coverage area.**).

### ***Conclusion***

Any inquiry concerning this communication or earlier communications from the examiner should be directed to GINA MCKIE whose telephone number is (571)270-5148. The examiner can normally be reached on Mon-Fri, 8:30 AM-5:00 PM EST.

Examiner interviews are available via telephone, in-person, and video conferencing using a USPTO supplied web-based collaboration tool. To schedule an interview, applicant is encouraged to use the USPTO Automated Interview Request (AIR) at <http://www.uspto.gov/interviewpractice>.

If attempts to reach the examiner by telephone are unsuccessful, the examiner's supervisor, Shuwang Liu can be reached on 571-272-3036. The fax phone number for the organization where this application or proceeding is assigned is 571-273-8300.

Information regarding the status of an application may be obtained from the Patent Application Information Retrieval (PAIR) system. Status information for published applications may be obtained from either Private PAIR or Public PAIR. Status information for unpublished applications is available through Private PAIR only. For more information about the PAIR system, see <http://pair-direct.uspto.gov>. Should you have questions on access to the Private PAIR system, contact the Electronic Business Center (EBC) at 866-217-9197 (toll-free). If you would like assistance from a USPTO Customer Service Representative or access to the automated information system, call 800-786-9199 (IN USA OR CANADA) or 571-272-1000.

Application/Control Number: 15/495,539

Page 25

Art Unit: 2631

/GINA MCKIE/

Examiner, Art Unit 2631

/SHUWANG LIU/

Supervisory Patent Examiner, Art Unit 2631

<b>Notice of References Cited</b>	Application/Control No. 15/495,539	Applicant(s)/Patent Under Reexamination DA SILVA ET AL.	
	Examiner GINA MCKIE	Art Unit 2631	Page 1 of 1

**U.S. PATENT DOCUMENTS**

*		Document Number Country Code-Number-Kind Code	Date MM-YYYY	Name	CPC Classification	US Classification
*	A	US-2002/0158801 A1	10-2002	Crilly, William J. JR.	G01S13/74	342/378
*	B	US-6,714,584 B1	03-2004	Ishii; Naoto	H04B7/086	375/144
	C	US-				
	D	US-				
	E	US-				
	F	US-				
	G	US-				
	H	US-				
	I	US-				
	J	US-				
	K	US-				
	L	US-				
	M	US-				

**FOREIGN PATENT DOCUMENTS**


*		Document Number Country Code-Number-Kind Code	Date MM-YYYY	Country	Name	CPC Classification
	N					
	O					
	P					
	Q					
	R					
	S					
	T					

**NON-PATENT DOCUMENTS**

*		Include as applicable: Author, Title Date, Publisher, Edition or Volume, Pertinent Pages)
	U	
	V	
	W	
	X	

\*A copy of this reference is not being furnished with this Office action. (See MPEP § 707.05(a).)  
Dates in MM-YYYY format are publication dates. Classifications may be US or foreign.



<b><i>Index of Claims</i></b> 	<b>Application/Control No.</b> 15495539	<b>Applicant(s)/Patent Under Reexamination</b> DA SILVA ET AL.
	<b>Examiner</b> GINA MCKIE	<b>Art Unit</b> 2631

✓	<b>Rejected</b>
=	<b>Allowed</b>

-	<b>Cancelled</b>
÷	<b>Restricted</b>

N	<b>Non-Elected</b>
I	<b>Interference</b>

A	<b>Appeal</b>
O	<b>Objected</b>

Claims renumbered in the same order as presented by applicant
  CPA
  T.D.
  R.1.47

CLAIM		DATE							
Final	Original	06/21/2017							
	1	✓							
	2	✓							
	3	✓							
	4	✓							
	5	✓							
	6	✓							
	7	✓							
	8	✓							
	9	✓							
	10	✓							
	11	✓							
	12	✓							
	13	✓							
	14	✓							
	15	✓							
	16	✓							
	17	✓							
	18	✓							
	19	✓							
	20	✓							

## EAST Search History

## EAST Search History (Prior Art)

Ref #	Hits	Search Query	DBs	Default Operator	Plurals	Time Stamp
L1	788	(multibeam "multi-beam") WITH directed	US-PGPUB; USPAT; USOCR; FPRS; EPO; JPO; DERWENT; IBM_TDB	OR	OFF	2017/06/26 08:52
L2	93367	antenna NEAR2 array	US-PGPUB; USPAT; USOCR; FPRS; EPO; JPO; DERWENT; IBM_TDB	OR	OFF	2017/06/26 09:16
L3	243	1 AND 2	US-PGPUB; USPAT; USOCR; FPRS; EPO; JPO; DERWENT; IBM_TDB	OR	OFF	2017/06/26 09:16
L4	68324	remote NEAR2 station	US-PGPUB; USPAT; USOCR; FPRS; EPO; JPO; DERWENT; IBM_TDB	OR	OFF	2017/06/26 09:17
L5	7	3 and 4	US-PGPUB; USPAT; USOCR; FPRS; EPO; JPO; DERWENT; IBM_TDB	OR	OFF	2017/06/26 09:31
L6	3	"13855410"	US-PGPUB; USPAT; USOCR; FPRS; EPO; JPO; DERWENT; IBM_TDB	OR	OFF	2017/06/26 09:42
L7	26335	(multibeam "multi-beam")	US-PGPUB; USPAT; USOCR; FPRS; EPO; JPO; DERWENT; IBM_TDB	OR	OFF	2017/06/26 09:44
L8	101	2 AND 7 AND 4	US-PGPUB;	OR	OFF	2017/06/26

			USPAT; USOCR; FPRS; EPO; JPO; DERWENT; IBM_TDB			09:45
L9	3245	2 AND 7	US-PGPUB; USPAT; USOCR; FPRS; EPO; JPO; DERWENT; IBM_TDB	OR	OFF	2017/06/26 09:52
L10	7875	(multibeam "multi-beam") AND simultaneously	US-PGPUB; USPAT; USOCR; FPRS; EPO; JPO; DERWENT; IBM_TDB	OR	OFF	2017/06/26 10:12
L11	1537	2 AND (multibeam "multi-beam") AND simultaneously	US-PGPUB; USPAT; USOCR; FPRS; EPO; JPO; DERWENT; IBM_TDB	OR	OFF	2017/06/26 10:12
L12	729	2 AND (multibeam "multi-beam") AND (simultaneously WITH receiv\$3)	US-PGPUB; USPAT; USOCR; FPRS; EPO; JPO; DERWENT; IBM_TDB	OR	OFF	2017/06/26 10:16
L13	179	12 AND @ad<="20021104"	US-PGPUB; USPAT; USOCR; FPRS; EPO; JPO; DERWENT; IBM_TDB	OR	OFF	2017/06/26 10:18
L14	12694	(first NEAR2 signal) WITH (second NEAR2 signal) WITH (simultaneously)	US-PGPUB; USPAT; USOCR; FPRS; EPO; JPO; DERWENT; IBM_TDB	OR	OFF	2017/06/26 10:22
L15	36	7 AND 14	US-PGPUB; USPAT; USOCR; FPRS; EPO; JPO; DERWENT; IBM_TDB	OR	OFF	2017/06/26 10:23
L16	3560	(first NEAR2 signal) WITH (second NEAR2 signal) WITH receiv\$3 WITH (simultaneously)	US-PGPUB; USPAT; USOCR; FPRS; EPO; JPO; DERWENT;	OR	OFF	2017/06/26 10:23

			IBM_TDB			
L17	1	1 AND 16	US-PGPUB; USPAT; USOCR; FPRS; EPO; JPO; DERWENT; IBM_TDB	OR	OFF	2017/06/26 10:24
L18	83	2 AND 16	US-PGPUB; USPAT; USOCR; FPRS; EPO; JPO; DERWENT; IBM_TDB	OR	OFF	2017/06/26 10:25
L19	16	7 AND 16	US-PGPUB; USPAT; USOCR; FPRS; EPO; JPO; DERWENT; IBM_TDB	OR	OFF	2017/06/26 10:26
L20	53	13 AND weighting	US-PGPUB; USPAT; USOCR; FPRS; EPO; JPO; DERWENT; IBM_TDB	OR	OFF	2017/06/26 10:29
S1	5665	375/376.CCLS.	US-PGPUB; USPAT; USOCR; FPRS; EPO; JPO; DERWENT; IBM_TDB	OR	OFF	2017/06/26 06:07
S2	9	("5293405"   "5384551"   "Us5703853"   "Us5850422"   "5959563"   "Us5999056"   "Us6038266"   "6046630"   "Us6282690"   "6570916"   "6624688"   "Us6658054"   "6717995"   "677172582"   "6888905"   "Us699285582"   "7058150"   "717399382"   "731559682").PN.	US-PGPUB; USPAT	OR	OFF	2017/06/26 06:10
S3	1	(sampl\$3 NEAR2 voltage) WITH (edge NEAR2 crossing NEAR2 times)	US-PGPUB; USPAT; USOCR; FPRS; EPO; JPO; DERWENT; IBM_TDB	OR	OFF	2017/06/26 07:37
S4	20	(sampl\$3 NEAR2 voltage) WITH (edge NEAR2 crossing)	US-PGPUB; USPAT; USOCR; FPRS; EPO; JPO; DERWENT; IBM_TDB	OR	OFF	2017/06/26 07:37
S5	19	S4 AND adjacent	US-PGPUB; USPAT; USOCR;	OR	OFF	2017/06/26 07:38

EAST Search History


			FPRS; EPO; JPO; DERWENT; IBM_TDB			
S6	13095	recovered NEAR2 clock	US-PGPUB; USPAT; USOCR; FPRS; EPO; JPO; DERWENT; IBM_TDB	OR	OFF	2017/06/26 07:38
S7	5	S5 AND S6	US-PGPUB; USPAT; USOCR; FPRS; EPO; JPO; DERWENT; IBM_TDB	OR	OFF	2017/06/26 07:38

**EAST Search History (Interference)**

< This search history is empty >

**6/ 26/ 2017 10:42:20 AM**

**C:\ Users\ gmckie\ Documents\ EAST\ Workspaces\ 15209529.w sp**

<b>Search Notes</b>  	<b>Application/Control No.</b>  15495539	<b>Applicant(s)/Patent Under Reexamination</b>  DA SILVA ET AL.
	<b>Examiner</b>  GINA MCKIE	<b>Art Unit</b>  2631

CPC- SEARCHED		
Symbol	Date	Examiner
H04L7/042, H04L27/2675 (EAST keyword search)	6/22/2017	gmckie

CPC COMBINATION SETS - SEARCHED		
Symbol	Date	Examiner

US CLASSIFICATION SEARCHED			
Class	Subclass	Date	Examiner

SEARCH NOTES		
Search Notes	Date	Examiner
Performed double patenting search in EAST	6/21/2017	gmckie
Performed initial prior art search in EAST	6/21/2017	gmckie

INTERFERENCE SEARCH			
US Class/ CPC Symbol	US Subclass / CPC Group	Date	Examiner

--	--

Receipt date: 04/24/2017

15495539 - GAU: 2631

Doc code: IDS

PTO/SB/08a (03-15)

Doc description: Information Disclosure Statement (IDS) Filed

Approved for use through 07/31/2016. OMB 0651-0031

U.S. Patent and Trademark Office; U.S. DEPARTMENT OF COMMERCE

Under the Paperwork Reduction Act of 1995, no persons are required to respond to a collection of information unless it contains a valid OMB control number.

<b>INFORMATION DISCLOSURE STATEMENT BY APPLICANT</b> ( Not for submission under 37 CFR 1.99)	Application Number		
	Filing Date		
	First Named Inventor	Marcus DA SILVA	
	Art Unit	TBD	
	Examiner Name	TBD	
	Attorney Docket Number	E1027.800(T).US1D1C1C3	

U.S.PATENTS						Remove
Examiner Initial*	Cite No	Patent Number	Kind Code <sup>1</sup>	Issue Date	Name of Patentee or Applicant of cited Document	Pages,Columns,Lines where Relevant Passages or Relevant Figures Appear
	1	4231040		1980-10-28	Walker	
	2	5327143		1994-07-05	Goetz et al.	
	3	5771017		1998-06-23	Dean et al.	
	4	5809141		1998-09-15	Dent et al.	
	5	5987037		1999-11-16	Gans	
	6	6049307		2000-04-11	Lim	
	7	6091788		2000-07-18	Keskitalo et al.	
	8	6104935		2000-08-15	Smith et al.	

**INFORMATION DISCLOSURE  
STATEMENT BY APPLICANT**  
( Not for submission under 37 CFR 1.99)

Application Number		
Filing Date		
First Named Inventor	Marcus DA SILVA	
Art Unit	TBD	
Examiner Name	TBD	
Attorney Docket Number	E1027.800(T).US1D1C1C3	

9	6108323		2000-08-22	Gray
10	6141335		2000-10-31	Kuwahara et al.
11	6169910		2001-01-02	Tamil et al.
12	6311075		2001-10-30	Bevan et al.
13	6337659		2002-01-08	Kim
14	6438376		2002-08-20	Elliott et al.
15	6470195		2002-10-22	Meyer
16	6611695		2003-08-26	Periyalwar
17	6628235		2003-09-30	Wight
18	6631277		2003-10-07	Berg et al.
19	6850741		2005-02-01	Lei et al.



**INFORMATION DISCLOSURE  
STATEMENT BY APPLICANT**  
( Not for submission under 37 CFR 1.99)

Application Number		
Filing Date		
First Named Inventor	Marcus DA SILVA	
Art Unit	TBD	
Examiner Name	TBD	
Attorney Docket Number	E1027.800(T).US1D1C1C3	

20	6907269		2005-06-14	Yamaguchi et al.
21	7346365		2008-03-18	Hovers et al.
22	9462589	B2	2016-10-04	DA SILVA

If you wish to add additional U.S. Patent citation information please click the Add button.

Add

**U.S.PATENT APPLICATION PUBLICATIONS**

Remove

Examiner Initial*	Cite No	Publication Number	Kind Code <sup>1</sup>	Publication Date	Name of Patentee or Applicant of cited Document	Pages, Columns, Lines where Relevant Passages or Relevant Figures Appear
	1	20010033600	A1	2001-10-25	Yang et al.	
	2	20020103013	A1	2002-08-01	Watson et al.	
	3	20020158801	A1	2002-10-31	Crilly et al.	
	4	20030064752	A1	2003-04-03	Adachi et al.	
	5	20030073465	A1	2003-04-17	Li	
	6	20030114196	A1	2003-06-19	Chitrapu	

<b>INFORMATION DISCLOSURE STATEMENT BY APPLICANT ( Not for submission under 37 CFR 1.99)</b>	Application Number		
	Filing Date		
	First Named Inventor	Marcus DA SILVA	
	Art Unit	TBD	
	Examiner Name	TBD	
	Attorney Docket Number	E1027.800(T).US1D1C1C3	

7	20040063468	A1	2004-04-01	Frank
---	-------------	----	------------	-------

If you wish to add additional U.S. Published Application citation information please click the Add button.

**FOREIGN PATENT DOCUMENTS**

Examiner Initial*	Cite No	Foreign Document Number <sup>3</sup>	Country Code <sup>2</sup> i	Kind Code <sup>4</sup>	Publication Date	Name of Patentee or Applicant of cited Document	Pages, Columns, Lines where Relevant Passages or Relevant Figures Appear	T <sup>5</sup>
	1	9921391	WO	A2	1999-04-29	Radio Design Innovation Tj Ab		

If you wish to add additional Foreign Patent Document citation information please click the Add button.

**NON-PATENT LITERATURE DOCUMENTS**

Examiner Initials*	Cite No	Include name of the author (in CAPITAL LETTERS), title of the article (when appropriate), title of the item (book, magazine, journal, serial, symposium, catalog, etc), date, pages(s), volume-issue number(s), publisher, city and/or country where published.	T <sup>5</sup>
	1	Anastasi, et. al., "MAC Protocols for Wicdband Wireless Local Access: Evolution Towards Wireless ATM", IEEE Personal Communications Magazine, pp. 53-64, Oct. 1998.	
	2	Berg, J., "Building penetration loss along urban street microcells," in Proceedings of PIMRC '96--7th International Symposium on Personal, Indoor, and Mobile Communications, 3:795-797 (1996).	
	3	Damoss, E. and L. Correia, eds., COST 231 Final Report--Digital Mobile Radio--Towards Future Generation Systems. European Commission, Directorate General XIII, Report No. RJR 18957 (ISBN 92-828-54167), 516 pages (1999).	
	4	Deng, S., "Empirical Model of WWW Document Arrivals at Access Link," Communications, 1996. ICC '96, Conference Record, Converging Technologies for Tomorrow's Applications. 1996 IEEE International Conference, 197-202 (1996).	
	5	Gans et al., "High data rate indoor wireless communications using antenna arrays," in Proceedings of 6th International Symposium on Personal, Indoor and Mobile Radio Communications, 3:1040-1046 (1995).	

<b>INFORMATION DISCLOSURE STATEMENT BY APPLICANT ( Not for submission under 37 CFR 1.99)</b>	Application Number		
	Filing Date		
	First Named Inventor	Marcus DA SILVA	
	Art Unit	TBD	
	Examiner Name	TBD	
	Attorney Docket Number	E1027.800(T).US1D1C1C3	

6	German et al., "Wireless Indoor Channel Modeling: Statistical Agreement of Ray Tracing Simulations and Channel Sounding Measurements," in Proceeding of 2001 IEEE International Conference on Acoustics, Speech, and Signal Processing, 4:2501-2504 (2001).
7	Gucsalla, R., "Characterizing the Variability of Arrival Processes with Indexes of Dispersion", IEEE JSAC, 9(2):203-211 (1990).
8	Hashemi, H., "The Indoor Propagation Channel," Proceedings of the IEEE, 81 (7): 943-968 (1993).
9	Jakes, W.C., ed., Microwave Mobile Communications. Wiley, 1974. 645 pages.
10	Kivinen et al., "Empirical Characterization of Wide band Indoor radio Channel at 5.3 GHz," IEEE Transactions on Antennas and Propagation, 49(8): 1192-1203 (2001).
11	Leland et. Al., "On the Self-Similar Nature of Ethernet Traffic," IEEE/ACM Transactions on Networking, 2(1):1-15 (1994).
12	Medbo, J. and J. Berg, "Simple and accurate path loss modeling at 5 GHz in indoor environments with corridors," in Vehicular Technology Conference Fall 2000. IEEE VTS Fall VTC2000. 52nd Vehicular Technology Conference, 1:30-36 (2000).

If you wish to add additional non-patent literature document citation information please click the Add button

**EXAMINER SIGNATURE**

Examiner Signature	/GINA M MCKIE/	Date Considered	06/19/2017
--------------------	----------------	-----------------	------------

\*EXAMINER: Initial if reference considered, whether or not citation is in conformance with MPEP 609. Draw line through a citation if not in conformance and not considered. Include copy of this form with next communication to applicant.

<sup>1</sup> See Kind Codes of USPTO Patent Documents at [www.USPTO.GOV](http://www.USPTO.GOV) or MPEP 901.04. <sup>2</sup> Enter office that issued the document, by the two-letter code (WIPO Standard ST.3). <sup>3</sup> For Japanese patent documents, the indication of the year of the reign of the Emperor must precede the serial number of the patent document. <sup>4</sup> Kind of document by the appropriate symbols as indicated on the document under WIPO Standard ST.16 if possible. <sup>5</sup> Applicant is to place a check mark here if English language translation is attached.

<b>INFORMATION DISCLOSURE STATEMENT BY APPLICANT ( Not for submission under 37 CFR 1.99)</b>	Application Number		
	Filing Date		
	First Named Inventor	Marcus DA SILVA	
	Art Unit	TBD	
	Examiner Name	TBD	
	Attorney Docket Number	E1027.800(T).US1D1C1C3	

**CERTIFICATION STATEMENT**

Please see 37 CFR 1.97 and 1.98 to make the appropriate selection(s):

That each item of information contained in the information disclosure statement was first cited in any communication from a foreign patent office in a counterpart foreign application not more than three months prior to the filing of the information disclosure statement. See 37 CFR 1.97(e)(1).

**OR**

That no item of information contained in the information disclosure statement was cited in a communication from a foreign patent office in a counterpart foreign application, and, to the knowledge of the person signing the certification after making reasonable inquiry, no item of information contained in the information disclosure statement was known to any individual designated in 37 CFR 1.56(c) more than three months prior to the filing of the information disclosure statement. See 37 CFR 1.97(e)(2).

See attached certification statement.

The fee set forth in 37 CFR 1.17 (p) has been submitted herewith.

A certification statement is not submitted herewith.

**SIGNATURE**

A signature of the applicant or representative is required in accordance with CFR 1.33, 10.18. Please see CFR 1.4(d) for the form of the signature.

Signature	/Nicholas R. Transier/	Date (YYYY-MM-DD)	2017-04-24
Name/Print	Nicholas R. TRANSIER	Registration Number	68743

This collection of information is required by 37 CFR 1.97 and 1.98. The information is required to obtain or retain a benefit by the public which is to file (and by the USPTO to process) an application. Confidentiality is governed by 35 U.S.C. 122 and 37 CFR 1.14. This collection is estimated to take 1 hour to complete, including gathering, preparing and submitting the completed application form to the USPTO. Time will vary depending upon the individual case. Any comments on the amount of time you require to complete this form and/or suggestions for reducing this burden, should be sent to the Chief Information Officer, U.S. Patent and Trademark Office, U.S. Department of Commerce, P.O. Box 1450, Alexandria, VA 22313-1450. **DO NOT SEND FEES OR COMPLETED FORMS TO THIS ADDRESS. SEND TO: Commissioner for Patents, P.O. Box 1450, Alexandria, VA 22313-1450.**

## Privacy Act Statement

The Privacy Act of 1974 (P.L. 93-579) requires that you be given certain information in connection with your submission of the attached form related to a patent application or patent. Accordingly, pursuant to the requirements of the Act, please be advised that: (1) the general authority for the collection of this information is 35 U.S.C. 2(b)(2); (2) furnishing of the information solicited is voluntary; and (3) the principal purpose for which the information is used by the U.S. Patent and Trademark Office is to process and/or examine your submission related to a patent application or patent. If you do not furnish the requested information, the U.S. Patent and Trademark Office may not be able to process and/or examine your submission, which may result in termination of proceedings or abandonment of the application or expiration of the patent.

The information provided by you in this form will be subject to the following routine uses:

1. The information on this form will be treated confidentially to the extent allowed under the Freedom of Information Act (5 U.S.C. 552) and the Privacy Act (5 U.S.C. 552a). Records from this system of records may be disclosed to the Department of Justice to determine whether the Freedom of Information Act requires disclosure of these records.
2. A record from this system of records may be disclosed, as a routine use, in the course of presenting evidence to a court, magistrate, or administrative tribunal, including disclosures to opposing counsel in the course of settlement negotiations.
3. A record in this system of records may be disclosed, as a routine use, to a Member of Congress submitting a request involving an individual, to whom the record pertains, when the individual has requested assistance from the Member with respect to the subject matter of the record.
4. A record in this system of records may be disclosed, as a routine use, to a contractor of the Agency having need for the information in order to perform a contract. Recipients of information shall be required to comply with the requirements of the Privacy Act of 1974, as amended, pursuant to 5 U.S.C. 552a(m).
5. A record related to an International Application filed under the Patent Cooperation Treaty in this system of records may be disclosed, as a routine use, to the International Bureau of the World Intellectual Property Organization, pursuant to the Patent Cooperation Treaty.
6. A record in this system of records may be disclosed, as a routine use, to another federal agency for purposes of National Security review (35 U.S.C. 181) and for review pursuant to the Atomic Energy Act (42 U.S.C. 218(c)).
7. A record from this system of records may be disclosed, as a routine use, to the Administrator, General Services, or his/her designee, during an inspection of records conducted by GSA as part of that agency's responsibility to recommend improvements in records management practices and programs, under authority of 44 U.S.C. 2904 and 2906. Such disclosure shall be made in accordance with the GSA regulations governing inspection of records for this purpose, and any other relevant (i.e., GSA or Commerce) directive. Such disclosure shall not be used to make determinations about individuals.
8. A record from this system of records may be disclosed, as a routine use, to the public after either publication of the application pursuant to 35 U.S.C. 122(b) or issuance of a patent pursuant to 35 U.S.C. 151. Further, a record may be disclosed, subject to the limitations of 37 CFR 1.14, as a routine use, to the public if the record was filed in an application which became abandoned or in which the proceedings were terminated and which application is referenced by either a published application, an application open to public inspections or an issued patent.
9. A record from this system of records may be disclosed, as a routine use, to a Federal, State, or local law enforcement agency, if the USPTO becomes aware of a violation or potential violation of law or regulation.


**UNITED STATES PATENT AND TRADEMARK OFFICE**

UNITED STATES DEPARTMENT OF COMMERCE  
**United States Patent and Trademark Office**  
 Address: COMMISSIONER FOR PATENTS  
 P.O. Box 1450  
 Alexandria, Virginia 22313-1450  
 www.uspto.gov

**BIB DATA SHEET**
**CONFIRMATION NO. 1050**

SERIAL NUMBER	FILING or 371(c) DATE RULE	CLASS	GROUP ART UNIT	ATTORNEY DOCKET NO.		
15/495,539	04/24/2017	375	2631 E	027.800(T).US1D1C1C3		
<b>APPLICANTS</b> XR Communications, LLC D/B/A Vivato Technologies, Solana Beach, CA;						
<b>INVENTORS</b> Marcus Da Silva, Spokane, WA; William J. Crilly JR., Liberty Lake, WA; James Brennan, Sammamish, WA; Robert J. Conley, Liberty Lake, WA; Siavash Alamouti, Spokane, WA; Eduardo Casas, Vancouver, CANADA; Hujun Yin, Spokane, WA; Bobby Jose, Veradale, WA; Yang-Seok Choi, Liberty Lake, WA; Vahid Tarokh, Cambridge, MA; Praveen Mehrotra, Spokane, WA;						
<b>** CONTINUING DATA *****</b> This application is a CON of 15/260,147 09/08/2016 which is a CON of 13/855,410 04/02/2013 PAT 9462589 which is a DIV of 10/700,329 11/03/2003 PAT 8412106 which claims benefit of 60/423,660 11/04/2002						
<b>** FOREIGN APPLICATIONS *****</b>						
<b>** IF REQUIRED, FOREIGN FILING LICENSE GRANTED ** ** SMALL ENTITY **</b>						
Foreign Priority claimed <input type="checkbox"/> Yes <input checked="" type="checkbox"/> No	35 USC 119(a-d) conditions met <input type="checkbox"/> Yes <input checked="" type="checkbox"/> No	<input type="checkbox"/> Met after Allowance Initials	<b>STATE OR COUNTRY</b> WA	<b>SHEETS DRAWINGS</b> 18	<b>TOTAL CLAIMS</b> 20	<b>INDEPENDENT CLAIMS</b> 3
<b>ADDRESS</b> EIP US LLP 2468 Historic Decatur Road Suite 200 San Diego, CA 92106 UNITED STATES						
<b>TITLE</b> DIRECTED WIRELESS COMMUNICATION						
<b>FILING FEE RECEIVED</b> 730	FEES: Authority has been given in Paper No. _____ to charge/credit DEPOSIT ACCOUNT No. _____ for following:			<input type="checkbox"/> All Fees <input type="checkbox"/> 1.16 Fees (Filing) <input type="checkbox"/> 1.17 Fees (Processing Ext. of time) <input type="checkbox"/> 1.18 Fees (Issue) <input type="checkbox"/> Other _____		

BIB (Rev. 05/07).

**IN THE UNITED STATES PATENT AND TRADEMARK OFFICE**

Applicant:	XR Communications, LLC DBA Vivato Technologies
Application No.:	15/495,539
Filing Date:	April 24, 2017
Title:	DIRECTED WIRELESS COMMUNICATION
Examiner:	To be assigned
Art Unit:	2642
Confirmation No.:	1050

**PRELIMINARY AMENDMENT**

**Mail Stop Amendment**

Commissioner for Patents  
P.O. Box 1450  
Alexandria, VA 22313-1450

Dear Examiner:

Please amend this application according to the following:

**Amendments to the Claims** begin on page 2 of this paper.

**Remarks** begin on page 7 of this paper.

## Electronic Acknowledgement Receipt

<b>EFS ID:</b>	29543034
<b>Application Number:</b>	15495539
<b>International Application Number:</b>	
<b>Confirmation Number:</b>	1050
<b>Title of Invention:</b>	DIRECTED WIRELESS COMMUNICATION
<b>First Named Inventor/Applicant Name:</b>	Marcus Da Silva
<b>Customer Number:</b>	114581
<b>Filer:</b>	Nicholas R. Transier/Jenny Stedman
<b>Filer Authorized By:</b>	Nicholas R. Transier
<b>Attorney Docket Number:</b>	E1027.800(T).US1D1C1C3
<b>Receipt Date:</b>	19-JUN-2017
<b>Filing Date:</b>	24-APR-2017
<b>Time Stamp:</b>	19:13:41
<b>Application Type:</b>	Utility under 35 USC 111(a)

### Payment information:

Submitted with Payment	no
------------------------	----

### File Listing:

Document Number	Document Description	File Name	File Size(Bytes)/ Message Digest	Multi Part /.zip	Pages (if appl.)
1		2017-06-19_Preliminary_Amen dment_E1027_800T_US1D1C1 C3.pdf	40221  2876db0b1df2253eedde10ea8311525fc3d 751ae	yes	7



<b>Multipart Description/PDF files in .zip description</b>		
<b>Document Description</b>	<b>Start</b>	<b>End</b>
Applicant Arguments/Remarks Made in an Amendment	7	7
Claims	2	6
Preliminary Amendment	1	1

**Warnings:**

**Information:**

<b>Total Files Size (in bytes):</b>	40221
-------------------------------------	-------

**This Acknowledgement Receipt evidences receipt on the noted date by the USPTO of the indicated documents, characterized by the applicant, and including page counts, where applicable. It serves as evidence of receipt similar to a Post Card, as described in MPEP 503.**

**New Applications Under 35 U.S.C. 111**

**If a new application is being filed and the application includes the necessary components for a filing date (see 37 CFR 1.53(b)-(d) and MPEP 506), a Filing Receipt (37 CFR 1.54) will be issued in due course and the date shown on this Acknowledgement Receipt will establish the filing date of the application.**

**National Stage of an International Application under 35 U.S.C. 371**

**If a timely submission to enter the national stage of an international application is compliant with the conditions of 35 U.S.C. 371 and other applicable requirements a Form PCT/DO/EO/903 indicating acceptance of the application as a national stage submission under 35 U.S.C. 371 will be issued in addition to the Filing Receipt, in due course.**

**New International Application Filed with the USPTO as a Receiving Office**

**If a new international application is being filed and the international application includes the necessary components for an international filing date (see PCT Article 11 and MPEP 1810), a Notification of the International Application Number and of the International Filing Date (Form PCT/RO/105) will be issued in due course, subject to prescriptions concerning national security, and the date shown on this Acknowledgement Receipt will establish the international filing date of the application.**

**REMARKS**

Claims 1-20 are currently pending in this application. By this paper, Applicant amends Claims 1, 2, 6-10, 14-17, and 20. No claims are cancelled and no new matter is added. Upon entry of these amendments, Claims 1-20 are pending for further review and consideration in light of the arguments presented below.

Discussion of Claim Amendments

Claims 1, 2, 6-10, 14-17, and 20 have been amended for clarity.

No Disclaimers or Disavowals

This response includes alterations to the claims. Applicant is not conceding in this Response that previously pending claims are not patentable. Rather, the alterations or characterizations are made for the purpose of facilitating expeditious prosecution of this application. Applicant reserves the right to pursue at a later date any previously pending claim, whether narrower or broader, that captures subject matter supported by this Application's disclosure. As a result, reviewers of this or any prosecution history of a related application should not infer that Applicant has made any disclaimers or disavowals of any subject matter supported by the present application.

**CONCLUSION**

Applicant respectfully requests entry of the claim amendments. Please charge any additional fees, including any fees for additional extension of time, or credit overpayment to Deposit Account No. 506237.

Respectfully submitted,

EIP US LLP

Dated: June 19, 2017

By:           / Nicholas R. Transier /  
Nicholas R. TRANSIER  
Registration No. 68,743  
Attorney of Record  
Customer No. 114581  
(619) 795-1300

### LISTING OF CLAIMS

1. **(Currently Amended)** A receiver for use in a wireless communications system, the receiver comprising:

~~an smart-antenna comprising at least a first antenna element and a second antenna element;~~

a transceiver operatively coupled to the ~~smart-antenna~~ and configured to transmit and receive electromagnetic signals using the ~~smart-antenna~~; and

a processor operatively coupled to the transceiver, the processor configured to:

receive a first signal transmission from a remote station via the ~~first antenna element~~ and a second signal transmission from the remote station via the ~~second antenna element~~ simultaneously;

determine first signal information for the first signal transmission;

determine second signal information for the second signal transmission, wherein the second signal information is different than the first signal information;

determine a set of weighting values based on the first signal information and the second signal information, wherein the set of weighting values is configured to be used by the remote station to construct one or more beam-formed transmission signals; and

cause the transceiver to generate ~~the one or more beam-formed transmission signals based on a third signal comprising content based on~~ the set of weighting values ~~for transmission to the remote station.~~

2. **(Currently Amended)** The receiver as recited in Claim 1,

wherein ~~the antenna comprises a first antenna element and a second antenna element, and~~

~~wherein~~ the processor is further configured to:

~~receive the first signal transmission from the remote station via the first antenna element and the second signal transmission from the remote station via the second antenna element simultaneously; and~~

cause the transceiver to transmit ~~the one or more beam-formed transmission~~ third signal[s] to the remote station via the ~~smart-antenna~~.

3. (Original) The receiver as recited in Claim 1, wherein the first signal transmission and the second signal transmission comprise electromagnetic signals comprising one or more transmission peaks and one or more transmission nulls.

4. (Original) The receiver as recited in Claim 1, wherein the first signal transmission and the second signal transmission are directional transmissions.

5. (Original) The receiver as recited in Claim 1, wherein the set of weighting values is further based on one or more of: a transmit power level, a data transmit rate, an antenna direction, quality of service data, or timing data.

6. **(Currently Amended)** The receiver as recited in Claim 1, wherein the ~~one or more beam-formed transmission signals content~~ comprises data configured to be used by the remote station to modify the placement of one or more transmission peaks and one or more transmission nulls in a subsequent signal transmission.

7. **(Currently Amended)** The receiver as recited in Claim 1, wherein the processor is further configured to:

determine a plurality of signal strength indications for the first signal transmission;

determine a first signal strength average based on the plurality of signal strength indications for the first signal transmission;

determine a plurality of signal strength indications for the second signal transmission;

determine a second signal strength average based on the plurality of signal strength indications for the second signal transmission; and

cause the transceiver to generate ~~the one or more beam-formed transmission signals~~ a fourth signal based on the first signal strength average and the second signal strength average.

8. **(Currently Amended)** The receiver as recited in Claim ~~117~~, wherein the processor is further configured to: cause the transceiver to transmit the ~~fourth signal~~ ~~one or more beam-formed transmission signals~~ to the remote station via the ~~smart~~ antenna.

9. **(Currently Amended)** A method in a wireless communications system, the method comprising:

receiving a first signal transmission from a remote station via a first antenna element of an ~~smart~~-antenna and a second signal transmission from the remote station via a second antenna element of the ~~smart~~-antenna simultaneously;

determining first signal information for the first signal transmission;

determining second signal information for the second signal transmission, wherein the second signal information is different than the first signal information;

determining a set of weighting values based on the first signal information and the second signal information, wherein the set of weighting values is configured to be used by the remote station to construct one or more beam-formed transmission signals; and

~~generating the one or more beam-formed transmission signals based on~~transmitting to the remote station a third signal comprising content based on the set of weighting values for transmission to the remote station.

10. **(Currently Amended)** The method as recited in Claim 9, further comprising: transmitting the third signal ~~one or more beam-formed transmission signals~~ to the remote station via the ~~smart~~-antenna.

11. **(Original)** The method as recited in Claim 9, wherein the first signal transmission and the second signal transmission comprise electromagnetic signals comprising one or more transmission peaks and one or more transmission nulls.

12. **(Original)** The method as recited in Claim 9, wherein the first signal transmission and the second signal transmission are directional transmissions.

13. **(Original)** The method as recited in Claim 9, wherein the set of weighting values is further based on one or more of: a transmit power level, a data transmit rate, an antenna direction, quality of service data, or timing data.

14. **(Currently Amended)** The method as recited in Claim 9, wherein the ~~one or more beam-formed transmission signals~~ content comprises data configured to be used by the remote

station to modify the placement of one or more transmission peaks and one or more transmission nulls in a subsequent signal transmission.

15. **(Currently Amended)** The method as recited in Claim 9, ~~wherein the processor is further configured to~~ further comprising:

determining a plurality of signal strength indications for the first signal transmission;

determining a first signal strength average based on the plurality of signal strength indications for the first signal transmission;

determining a plurality of signal strength indications for the second signal transmission;

determining a second signal strength average based on the plurality of signal strength indications for the second signal transmission; and

~~generating the one or more beam-formed transmission~~ a fourth signal based on the first signal strength average and the second signal strength average.

16. **(Currently Amended)** The method as recited in Claim 15, ~~wherein the processor is further configured to~~ further comprising: causing the transceiver to transmit the ~~one or more beam-formed transmission~~ fourth signal to the remote station via the ~~smart antenna~~.

17. **(Currently Amended)** An apparatus for use in a wireless communications system, the apparatus comprising:

~~an antenna smart antenna comprising at least a first antenna element and a second antenna element;~~

a transceiver operatively coupled to the ~~smart antenna~~; and

a processor operatively coupled to the transceiver, the processor configured to:

receive a first signal transmission from a remote station via the ~~first antenna element~~, the first signal transmission comprising first signal information;

receive a second signal transmission from the remote station via the ~~second antenna element~~, the second signal transmission comprising second signal information;

determine a set of weighting values based on the first signal information and the second signal information, wherein the set of weighting values is configured to be used by the remote station to construct one or more beam-formed transmission signals;

cause the transceiver to ~~transmit the one or more beam-formed transmission signals~~ generate a third signal comprising content based on the set of weighting values ~~to the remote station~~.

18. (Original) The apparatus as recited in Claim 17, wherein the first signal transmission and the second signal transmission comprise electromagnetic signals comprising one or more transmission peaks and one or more transmission nulls.

19. (Original) The apparatus as recited in Claim 17, wherein the first signal information comprises one or more of: a transmit power level, a data transmit rate, an antenna direction, quality of service data, or timing data.

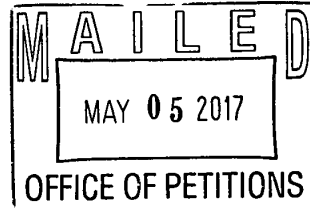
20. **(Currently Amended)** The apparatus as recited in Claim 17, wherein the antenna comprises a first antenna element and a second antenna element, and wherein the first antenna element and the second antenna element are directional antenna elements.



UNITED STATES PATENT AND TRADEMARK OFFICE

Commissioner for Patents  
United States Patent and Trademark Office  
P.O. Box 1450  
Alexandria, VA 22313-1450  
www.uspto.gov

EIP US LLP  
2468 Historic Decatur Road  
Suite 200  
San Diego CA 92106



Doc Code: TRACK1.GRANT

<b>Decision Granting Request for Prioritized Examination (Track I or After RCE)</b>	Application No.: 15/495,539
<p>In view of the specific circumstances surrounding this application and, in particular, the filing of the Track 1 Request requirements, the Office hereby waives, <i>sua sponte</i>, the Processing Fee date requirement of the Prioritized Examination, Track 1, program to the extent necessary to render the processing fee as timely paid and sufficient to fulfill such requirement.</p> <p>1. THE REQUEST FILED <u>April 24, 2017</u> IS <b>GRANTED</b>.</p> <p>The above-identified application has met the requirements for prioritized examination</p> <p>A. <input checked="" type="checkbox"/> for an original nonprovisional application (Track I).</p> <p>B. <input type="checkbox"/> for an application undergoing continued examination (RCE).</p> <p>2. <b>The above-identified application will undergo prioritized examination.</b> The application will be accorded special status throughout its entire course of prosecution until one of the following occurs:</p> <p>A. filing a <b><u>petition for extension of time</u></b> to extend the time period for filing a reply;</p> <p>B. filing an <b><u>amendment to amend the application to contain more than four independent claims, more than thirty total claims</u></b>, or a multiple dependent claim;</p> <p>C. filing a <b><u>request for continued examination</u></b>;</p> <p>D. filing a notice of appeal;</p> <p>E. filing a request for suspension of action;</p> <p>F. mailing of a notice of allowance;</p> <p>G. mailing of a final Office action;</p> <p>H. completion of examination as defined in 37 CFR 41.102; or</p> <p>I. abandonment of the application.</p> <p>Telephone inquiries with regard to this decision should be directed to Brian W. Brown at 571-272-5338.</p> <p>/Brian W. Brown/ [Signature]</p> <p>Petitions Examiner, Office of Petitions (Title)</p>	





UNITED STATES PATENT AND TRADEMARK OFFICE

UNITED STATES DEPARTMENT OF COMMERCE
United States Patent and Trademark Office
Address: COMMISSIONER FOR PATENTS
P.O. Box 1450
Alexandria, Virginia 22313-1450
www.uspto.gov

Table with 7 columns: APPLICATION NUMBER, FILING or 371(c) DATE, GRP ART UNIT, FIL FEE REC'D, ATTY. DOCKET NO, TOT CLAIMS, IND CLAIMS. Row 1: 15/495,539, 04/24/2017, 2642, 730, E1027.800(T).US1D1C1C3, 20, 3

CONFIRMATION NO. 1050

FILING RECEIPT



114581
EIP US LLP
2468 Historic Decatur Road
Suite 200
San Diego, CA 92106

Date Mailed: 05/01/2017

Receipt is acknowledged of this non-provisional patent application. The application will be taken up for examination in due course. Applicant will be notified as to the results of the examination. Any correspondence concerning the application must include the following identification information: the U.S. APPLICATION NUMBER, FILING DATE, NAME OF APPLICANT, and TITLE OF INVENTION. Fees transmitted by check or draft are subject to collection. Please verify the accuracy of the data presented on this receipt. If an error is noted on this Filing Receipt, please submit a written request for a Filing Receipt Correction. Please provide a copy of this Filing Receipt with the changes noted thereon. If you received a "Notice to File Missing Parts" for this application, please submit any corrections to this Filing Receipt with your reply to the Notice. When the USPTO processes the reply to the Notice, the USPTO will generate another Filing Receipt incorporating the requested corrections

Inventor(s)

- Marcus Da Silva, Spokane, WA;
William J. Crilly JR., Liberty Lake, WA;
James Brennan, Sammamish, WA;
Robert J. Conley, Liberty Lake, WA;
Siavash Alamouti, Spokane, WA;
Eduardo Casas, Vancouver, CANADA;
Hujun Yin, Spokane, WA;
Bobby Jose, Veradale, WA;
Yang-Seok Choi, Liberty Lake, WA;
Vahid Tarokh, Cambridge, MA;
Praveen Mehrotra, Spokane, WA;

Applicant(s)

XR Communications, LLC D/B/A Vivato Technologies, Solana Beach, CA;

Power of Attorney: The patent practitioners associated with Customer Number 114581

Domestic Priority data as claimed by applicant

This application is a CON of 15/260,147 09/08/2016
which is a CON of 13/855,410 04/02/2013 PAT 9462589
which is a DIV of 10/700,329 11/03/2003 PAT 8412106
which claims benefit of 60/423,660 11/04/2002

Foreign Applications for which priority is claimed (You may be eligible to benefit from the Patent Prosecution Highway program at the USPTO. Please see http://www.uspto.gov for more information.) - None.

Foreign application information must be provided in an Application Data Sheet in order to constitute a claim to foreign priority. See 37 CFR 1.55 and 1.76.

**Permission to Access Application via Priority Document Exchange:** Yes

**Permission to Access Search Results:** Yes

Applicant may provide or rescind an authorization for access using Form PTO/SB/39 or Form PTO/SB/69 as appropriate.

**Projected Publication Date:** 08/10/2017

**Non-Publication Request:** No

**Early Publication Request:** No

**\*\* SMALL ENTITY \*\***

**Title**

DIRECTED WIRELESS COMMUNICATION

**Preliminary Class**

455

**Statement under 37 CFR 1.55 or 1.78 for AIA (First Inventor to File) Transition Applications:** No

## **PROTECTING YOUR INVENTION OUTSIDE THE UNITED STATES**

Since the rights granted by a U.S. patent extend only throughout the territory of the United States and have no effect in a foreign country, an inventor who wishes patent protection in another country must apply for a patent in a specific country or in regional patent offices. Applicants may wish to consider the filing of an international application under the Patent Cooperation Treaty (PCT). An international (PCT) application generally has the same effect as a regular national patent application in each PCT-member country. The PCT process **simplifies** the filing of patent applications on the same invention in member countries, but **does not result** in a grant of "an international patent" and does not eliminate the need of applicants to file additional documents and fees in countries where patent protection is desired.

Almost every country has its own patent law, and a person desiring a patent in a particular country must make an application for patent in that country in accordance with its particular laws. Since the laws of many countries differ in various respects from the patent law of the United States, applicants are advised to seek guidance from specific foreign countries to ensure that patent rights are not lost prematurely.

Applicants also are advised that in the case of inventions made in the United States, the Director of the USPTO must issue a license before applicants can apply for a patent in a foreign country. The filing of a U.S. patent application serves as a request for a foreign filing license. The application's filing receipt contains further information and guidance as to the status of applicant's license for foreign filing.

Applicants may wish to consult the USPTO booklet, "General Information Concerning Patents" (specifically, the section entitled "Treaties and Foreign Patents") for more information on timeframes and deadlines for filing foreign patent applications. The guide is available either by contacting the USPTO Contact Center at 800-786-9199, or it can be viewed on the USPTO website at <http://www.uspto.gov/web/offices/pac/doc/general/index.html>.

For information on preventing theft of your intellectual property (patents, trademarks and copyrights), you may wish to consult the U.S. Government website, <http://www.stopfakes.gov>. Part of a Department of Commerce initiative,

page 2 of 4

this website includes self-help "toolkits" giving innovators guidance on how to protect intellectual property in specific countries such as China, Korea and Mexico. For questions regarding patent enforcement issues, applicants may call the U.S. Government hotline at 1-866-999-HALT (1-866-999-4258).

**LICENSE FOR FOREIGN FILING UNDER**  
**Title 35, United States Code, Section 184**  
**Title 37, Code of Federal Regulations, 5.11 & 5.15**

**GRANTED**

The applicant has been granted a license under 35 U.S.C. 184, if the phrase "IF REQUIRED, FOREIGN FILING LICENSE GRANTED" followed by a date appears on this form. Such licenses are issued in all applications where the conditions for issuance of a license have been met, regardless of whether or not a license may be required as set forth in 37 CFR 5.15. The scope and limitations of this license are set forth in 37 CFR 5.15(a) unless an earlier license has been issued under 37 CFR 5.15(b). The license is subject to revocation upon written notification. The date indicated is the effective date of the license, unless an earlier license of similar scope has been granted under 37 CFR 5.13 or 5.14.

This license is to be retained by the licensee and may be used at any time on or after the effective date thereof unless it is revoked. This license is automatically transferred to any related applications(s) filed under 37 CFR 1.53(d). This license is not retroactive.

The grant of a license does not in any way lessen the responsibility of a licensee for the security of the subject matter as imposed by any Government contract or the provisions of existing laws relating to espionage and the national security or the export of technical data. Licensees should apprise themselves of current regulations especially with respect to certain countries, of other agencies, particularly the Office of Defense Trade Controls, Department of State (with respect to Arms, Munitions and Implements of War (22 CFR 121-128)); the Bureau of Industry and Security, Department of Commerce (15 CFR parts 730-774); the Office of Foreign Assets Control, Department of Treasury (31 CFR Parts 500+) and the Department of Energy.

**NOT GRANTED**

No license under 35 U.S.C. 184 has been granted at this time, if the phrase "IF REQUIRED, FOREIGN FILING LICENSE GRANTED" DOES NOT appear on this form. Applicant may still petition for a license under 37 CFR 5.12, if a license is desired before the expiration of 6 months from the filing date of the application. If 6 months has lapsed from the filing date of this application and the licensee has not received any indication of a secrecy order under 35 U.S.C. 181, the licensee may foreign file the application pursuant to 37 CFR 5.15(b).

---

**SelectUSA**

The United States represents the largest, most dynamic marketplace in the world and is an unparalleled location for business investment, innovation, and commercialization of new technologies. The U.S. offers tremendous resources and advantages for those who invest and manufacture goods here. Through SelectUSA, our nation works to promote and facilitate business investment. SelectUSA provides information assistance to the international investor community; serves as an ombudsman for existing and potential investors; advocates on behalf of U.S. cities, states, and regions competing for global investment; and counsels U.S. economic development organizations on investment attraction best practices. To learn more about why the United States is the best country in the world to develop

technology, manufacture products, deliver services, and grow your business, visit <http://www.SelectUSA.gov> or call +1-202-482-6800.



UNITED STATES PATENT AND TRADEMARK OFFICE

UNITED STATES DEPARTMENT OF COMMERCE  
United States Patent and Trademark Office  
Address: COMMISSIONER FOR PATENTS  
P.O. Box 1450  
Alexandria, Virginia 22313-1450  
www.uspto.gov

APPLICATION NUMBER	FILING OR 371(C) DATE	FIRST NAMED APPLICANT	ATTY. DOCKET NO./TITLE
15/495,539	04/24/2017	Marcus Da Silva	E1027.800(T).US1D1C1C3

**CONFIRMATION NO. 1050**

114581  
EIP US LLP  
2468 Historic Decatur Road  
Suite 200  
San Diego, CA 92106

**37 CFR 1.48(f)  
ACKNOWLEDGEMENT LETTER**



Date Mailed: 05/01/2017

**NOTICE OF ACCEPTANCE OF REQUEST UNDER 37 CFR 1.48(f)**

This is in response to the applicant's request under 37 CFR 1.48(f) submitted on 04/27/2017.

The request under 37 CFR 1.48(f) to correct the inventorship, to correct or update the name of an inventor, or to correct the order of names of joint inventors is accepted.

Questions about the contents of this notice and the requirements it sets forth should be directed to the Office of Data Management, Application Assistance Unit, at (571) 272-4000 or (571) 272-4200 or 1-888-786-0101.

/tpnguyen/



UNITED STATES PATENT AND TRADEMARK OFFICE

UNITED STATES DEPARTMENT OF COMMERCE
United States Patent and Trademark Office
Address: COMMISSIONER FOR PATENTS
P.O. Box 1450
Alexandria, Virginia 22313-1450
www.uspto.gov

Table with 7 columns: APPLICATION NUMBER, FILING or 371(c) DATE, GRP ART UNIT, FIL FEE REC'D, ATTY. DOCKET NO, TOT CLAIMS, IND CLAIMS. Row 1: 15/495,539, 04/24/2017, 2411, 730, E1027.800(T).US1D1C1C3, 20, 3

CONFIRMATION NO. 1050

UPDATED FILING RECEIPT



114581
EIP US LLP
2468 Historic Decatur Road
Suite 200
San Diego, CA 92106

Date Mailed: 05/01/2017

Receipt is acknowledged of this non-provisional patent application. The application will be taken up for examination in due course. Applicant will be notified as to the results of the examination. Any correspondence concerning the application must include the following identification information: the U.S. APPLICATION NUMBER, FILING DATE, NAME OF APPLICANT, and TITLE OF INVENTION. Fees transmitted by check or draft are subject to collection. Please verify the accuracy of the data presented on this receipt. If an error is noted on this Filing Receipt, please submit a written request for a Filing Receipt Correction. Please provide a copy of this Filing Receipt with the changes noted thereon. If you received a "Notice to File Missing Parts" for this application, please submit any corrections to this Filing Receipt with your reply to the Notice. When the USPTO processes the reply to the Notice, the USPTO will generate another Filing Receipt incorporating the requested corrections

Inventor(s)

- Marcus Da Silva, Spokane, WA;
William J. Crilly JR., Liberty Lake, WA;
James Brennan, Sammamish, WA;
Robert J. Conley, Liberty Lake, WA;
Siavash Alamouti, Spokane, WA;
Eduardo Casas, Vancouver, CANADA;
Hujun Yin, Spokane, WA;
Bobby Jose, Veradale, WA;
Yang-Seok Choi, Liberty Lake, WA;
Vahid Tarokh, Cambridge, MA;
Praveen Mehrotra, Spokane, WA;

Applicant(s)

XR Communications, LLC D/B/A Vivato Technologies, Solana Beach, CA;

Power of Attorney: The patent practitioners associated with Customer Number 114581

Domestic Priority data as claimed by applicant

This application is a CON of 15/260,147 09/08/2016
which is a CON of 13/855,410 04/02/2013 PAT 9462589
which is a DIV of 10/700,329 11/03/2003 PAT 8412106
which claims benefit of 60/423,660 11/04/2002

Foreign Applications for which priority is claimed (You may be eligible to benefit from the Patent Prosecution Highway program at the USPTO. Please see http://www.uspto.gov for more information.) - None.

Foreign application information must be provided in an Application Data Sheet in order to constitute a claim to foreign priority. See 37 CFR 1.55 and 1.76.

**Permission to Access Application via Priority Document Exchange:** Yes

**Permission to Access Search Results:** Yes

Applicant may provide or rescind an authorization for access using Form PTO/SB/39 or Form PTO/SB/69 as appropriate.

**Projected Publication Date:** 08/10/2017

**Non-Publication Request:** No

**Early Publication Request:** No

**\*\* SMALL ENTITY \*\***

**Title**

DIRECTED WIRELESS COMMUNICATION

**Preliminary Class**

370

**Statement under 37 CFR 1.55 or 1.78 for AIA (First Inventor to File) Transition Applications:** No

## **PROTECTING YOUR INVENTION OUTSIDE THE UNITED STATES**

Since the rights granted by a U.S. patent extend only throughout the territory of the United States and have no effect in a foreign country, an inventor who wishes patent protection in another country must apply for a patent in a specific country or in regional patent offices. Applicants may wish to consider the filing of an international application under the Patent Cooperation Treaty (PCT). An international (PCT) application generally has the same effect as a regular national patent application in each PCT-member country. The PCT process **simplifies** the filing of patent applications on the same invention in member countries, but **does not result** in a grant of "an international patent" and does not eliminate the need of applicants to file additional documents and fees in countries where patent protection is desired.

Almost every country has its own patent law, and a person desiring a patent in a particular country must make an application for patent in that country in accordance with its particular laws. Since the laws of many countries differ in various respects from the patent law of the United States, applicants are advised to seek guidance from specific foreign countries to ensure that patent rights are not lost prematurely.

Applicants also are advised that in the case of inventions made in the United States, the Director of the USPTO must issue a license before applicants can apply for a patent in a foreign country. The filing of a U.S. patent application serves as a request for a foreign filing license. The application's filing receipt contains further information and guidance as to the status of applicant's license for foreign filing.

Applicants may wish to consult the USPTO booklet, "General Information Concerning Patents" (specifically, the section entitled "Treaties and Foreign Patents") for more information on timeframes and deadlines for filing foreign patent applications. The guide is available either by contacting the USPTO Contact Center at 800-786-9199, or it can be viewed on the USPTO website at <http://www.uspto.gov/web/offices/pac/doc/general/index.html>.

For information on preventing theft of your intellectual property (patents, trademarks and copyrights), you may wish to consult the U.S. Government website, <http://www.stopfakes.gov>. Part of a Department of Commerce initiative,

page 2 of 4

this website includes self-help "toolkits" giving innovators guidance on how to protect intellectual property in specific countries such as China, Korea and Mexico. For questions regarding patent enforcement issues, applicants may call the U.S. Government hotline at 1-866-999-HALT (1-866-999-4258).

**LICENSE FOR FOREIGN FILING UNDER  
Title 35, United States Code, Section 184  
Title 37, Code of Federal Regulations, 5.11 & 5.15**

**GRANTED**

The applicant has been granted a license under 35 U.S.C. 184, if the phrase "IF REQUIRED, FOREIGN FILING LICENSE GRANTED" followed by a date appears on this form. Such licenses are issued in all applications where the conditions for issuance of a license have been met, regardless of whether or not a license may be required as set forth in 37 CFR 5.15. The scope and limitations of this license are set forth in 37 CFR 5.15(a) unless an earlier license has been issued under 37 CFR 5.15(b). The license is subject to revocation upon written notification. The date indicated is the effective date of the license, unless an earlier license of similar scope has been granted under 37 CFR 5.13 or 5.14.

This license is to be retained by the licensee and may be used at any time on or after the effective date thereof unless it is revoked. This license is automatically transferred to any related applications(s) filed under 37 CFR 1.53(d). This license is not retroactive.

The grant of a license does not in any way lessen the responsibility of a licensee for the security of the subject matter as imposed by any Government contract or the provisions of existing laws relating to espionage and the national security or the export of technical data. Licensees should apprise themselves of current regulations especially with respect to certain countries, of other agencies, particularly the Office of Defense Trade Controls, Department of State (with respect to Arms, Munitions and Implements of War (22 CFR 121-128)); the Bureau of Industry and Security, Department of Commerce (15 CFR parts 730-774); the Office of Foreign Assets Control, Department of Treasury (31 CFR Parts 500+) and the Department of Energy.

**NOT GRANTED**

No license under 35 U.S.C. 184 has been granted at this time, if the phrase "IF REQUIRED, FOREIGN FILING LICENSE GRANTED" DOES NOT appear on this form. Applicant may still petition for a license under 37 CFR 5.12, if a license is desired before the expiration of 6 months from the filing date of the application. If 6 months has lapsed from the filing date of this application and the licensee has not received any indication of a secrecy order under 35 U.S.C. 181, the licensee may foreign file the application pursuant to 37 CFR 5.15(b).

---

***SelectUSA***

The United States represents the largest, most dynamic marketplace in the world and is an unparalleled location for business investment, innovation, and commercialization of new technologies. The U.S. offers tremendous resources and advantages for those who invest and manufacture goods here. Through SelectUSA, our nation works to promote and facilitate business investment. SelectUSA provides information assistance to the international investor community; serves as an ombudsman for existing and potential investors; advocates on behalf of U.S. cities, states, and regions competing for global investment; and counsels U.S. economic development organizations on investment attraction best practices. To learn more about why the United States is the best country in the world to develop



technology, manufacture products, deliver services, and grow your business, visit <http://www.SelectUSA.gov> or call +1-202-482-6800.

<b>PATENT APPLICATION FEE DETERMINATION RECORD</b> Substitute for Form PTO-875	Application or Docket Number 15/495,539
---	--

APPLICATION AS FILED - PART I			SMALL ENTITY		OR	OTHER THAN SMALL ENTITY	
	(Column 1)	(Column 2)					
FOR	NUMBER FILED	NUMBER EXTRA	RATE(\$)	FEE(\$)		RATE(\$)	FEE(\$)
BASIC FEE <small>(37 CFR 1.16(a), (b), or (c))</small>	N/A	N/A	N/A	70		N/A	
SEARCH FEE <small>(37 CFR 1.16(k), (l), or (m))</small>	N/A	N/A	N/A	300		N/A	
EXAMINATION FEE <small>(37 CFR 1.16(o), (p), or (q))</small>	N/A	N/A	N/A	360		N/A	
TOTAL CLAIMS <small>(37 CFR 1.16(i))</small>	20	minus 20 = *	x 40 =	0.00	OR		
INDEPENDENT CLAIMS <small>(37 CFR 1.16(h))</small>	3	minus 3 = *	x 210 =	0.00			
APPLICATION SIZE FEE <small>(37 CFR 1.16(s))</small>	If the specification and drawings exceed 100 sheets of paper, the application size fee due is \$310 (\$155 for small entity) for each additional 50 sheets or fraction thereof. See 35 U.S.C. 41(a)(1)(G) and 37 CFR 1.16(s).			0.00			
MULTIPLE DEPENDENT CLAIM PRESENT <small>(37 CFR 1.16(j))</small>				0.00			
			TOTAL	730		TOTAL	

\* If the difference in column 1 is less than zero, enter "0" in column 2.

APPLICATION AS AMENDED - PART II					SMALL ENTITY		OR	OTHER THAN SMALL ENTITY	
	(Column 1)	(Column 2)	(Column 3)						
AMENDMENT A	CLAIMS REMAINING AFTER AMENDMENT	HIGHEST NUMBER PREVIOUSLY PAID FOR	PRESENT EXTRA	RATE(\$)	ADDITIONAL FEE(\$)		RATE(\$)	ADDITIONAL FEE(\$)	
	Total <small>(37 CFR 1.16(i))</small>	*	Minus **	=	x	=	OR	x	=
	Independent <small>(37 CFR 1.16(h))</small>	*	Minus ***	=	x	=	OR	x	=
	Application Size Fee <small>(37 CFR 1.16(s))</small>						OR		
	FIRST PRESENTATION OF MULTIPLE DEPENDENT CLAIM <small>(37 CFR 1.16(j))</small>						OR		
				TOTAL ADD'L FEE		OR	TOTAL ADD'L FEE		
AMENDMENT B	CLAIMS REMAINING AFTER AMENDMENT	HIGHEST NUMBER PREVIOUSLY PAID FOR	PRESENT EXTRA	RATE(\$)	ADDITIONAL FEE(\$)		RATE(\$)	ADDITIONAL FEE(\$)	
	Total <small>(37 CFR 1.16(i))</small>	*	Minus **	=	x	=	OR	x	=
	Independent <small>(37 CFR 1.16(h))</small>	*	Minus ***	=	x	=	OR	x	=
	Application Size Fee <small>(37 CFR 1.16(s))</small>						OR		
	FIRST PRESENTATION OF MULTIPLE DEPENDENT CLAIM <small>(37 CFR 1.16(j))</small>						OR		
				TOTAL ADD'L FEE		OR	TOTAL ADD'L FEE		

\* If the entry in column 1 is less than the entry in column 2, write "0" in column 3.  
 \*\* If the "Highest Number Previously Paid For" IN THIS SPACE is less than 20, enter "20".  
 \*\*\* If the "Highest Number Previously Paid For" IN THIS SPACE is less than 3, enter "3".  
 The "Highest Number Previously Paid For" (Total or Independent) is the highest found in the appropriate box in column 1.

**CORRECTED ADS FORM**

Application Number	15495539
Title of Invention	DIRECTED WIRELESS COMMUNICATION

**Inventor Information**

**\*\*If no data is shown, no data has been corrected\*\***

	Data of Record	Updated Data
Order Number	1	
Name	Marcus Da Silva	

**Residence Information**

Residency	us-residency	
City	Spokane	
State	WA	
Country of Residence	US	

**Mailing Address of Inventor**

Address 1	5510 East 25th	
Address 2		
City,State/Province, Postal Code	Spokane WA 99223	
Country	US	

Document Description: Application Data Sheet to update/correct info  
Doc Code: ADS.CORR

	Data of Record	Updated Data
Order Number	10	
Name	Vahid Tarokh	
<b>Residence Information</b>		
Residency	us-residency	
City	Cambridge	
State	MA	
Country of Residence	US	
<b>Mailing Address of Inventor</b>		
Address 1	157 Pleasant Street, Apt 305	
Address 2		
City,State/Province, Postal Code	Cambridge MA 02139	
Country	US	

Corrected ADS 1.0

	Data of Record	Updated Data
Order Number	11	
Name	Praveen Mehrotra	
<b>Residence Information</b>		
Residency	us-residency	
City	Spokane	
State	WA	
Country of Residence	US	
<b>Mailing Address of Inventor</b>		
Address 1	13303 East Mission Ave., Apt 75	
Address 2		
City,State/Province, Postal Code	Spokane WA 99216	
Country	US	

	Data of Record	Updated Data
Order Number	2	
Name	William J. Crilly	<u>William J. Crilly Jr.</u>
<b>Residence Information</b>		
Residency	us-residency	
City	Liberty Lake	
State	WA	
Country of Residence	US	
<b>Mailing Address of Inventor</b>		
Address 1	23825 E. 2nd Avenue Ct.	
Address 2		
City,State/Province, Postal Code	Liberty Lake WA 99019	
Country	US	

	Data of Record	Updated Data
Order Number	3	
Name	James Brennan	
<b>Residence Information</b>		
Residency	us-residency	
City	Sammamish	
State	WA	
Country of Residence	US	
<b>Mailing Address of Inventor</b>		
Address 1	414 213th PL SE	
Address 2		
City,State/Province, Postal Code	Sammamish WA 98074	
Country	US	

	Data of Record	Updated Data
Order Number	4	
Name	Robert J. Conley	
<b>Residence Information</b>		
Residency	us-residency	
City	Liberty Lake	
State	WA	
Country of Residence	US	
<b>Mailing Address of Inventor</b>		
Address 1	23326 E. 2nd Avenue	
Address 2		
City,State/Province, Postal Code	Liberty Lake WA 99019	
Country	US	



	Data of Record	Updated Data
Order Number	5	
Name	Siavash Alamouti	
<b>Residence Information</b>		
Residency	us-residency	
City	Spokane	
State	WA	
Country of Residence	US	
<b>Mailing Address of Inventor</b>		
Address 1	2123 West 1st Ave., Apt 3	
Address 2		
City,State/Province, Postal Code	Spokane WA 99204	
Country	US	

	Data of Record	Updated Data
Order Number	6	
Name	Eduardo Casas	
<b>Residence Information</b>		
Residency	non-us-residency	
City	Vancouver	
State		
Country of Residence	CA	
<b>Mailing Address of Inventor</b>		
Address 1	7542 Ontario Street	
Address 2		
City,State/Province, Postal Code	Vancouver V5X3C2	
Country	CA	

	Data of Record	Updated Data
Order Number	7	
Name	Hujun Yin	
<b>Residence Information</b>		
Residency	us-residency	
City	Spokane	
State	WA	
Country of Residence	US	
<b>Mailing Address of Inventor</b>		
Address 1	2415 N. Cherry Street, Apt. 23	
Address 2		
City,State/Province, Postal Code	Spokane WA 99216	
Country	US	

	Data of Record	Updated Data
Order Number	8	
Name	Bobby Jose	
<b>Residence Information</b>		
Residency	us-residency	
City	Veradale	
State	WA	
Country of Residence	US	
<b>Mailing Address of Inventor</b>		
Address 1	15821 East 4th Ave., Apt F 125	
Address 2		
City,State/Province, Postal Code	Veradale WA 99037	
Country	US	

	Data of Record	Updated Data
Order Number	9	
Name	Yang-Seok Choi	

**Residence Information**

Residency	us-residency	
City	Liberty Lake	
State	WA	
Country of Residence	US	

**Mailing Address of Inventor**

Address 1	22809 East Country Vista Drive, Apt 438	
Address 2		
City,State/Province, Postal Code	Liberty Lake WA 99019	
Country	US	

**Application Information**

	Data of Record	Updated Data
Title of Invention	DIRECTED WIRELESS COMMUNICATION	
Attorney Docket Number	E1027.800(T).US1D1C1C3	
Entity Type	Regular Undiscounted	

**Domestic Benefit/National Stage Information**

**\*\*If no data is shown, no data has been corrected\*\***

This section allows for the applicant to either claim benefit under 35 U.S.C. 119(e), 120, 121,365(c), or 386(c) or indicate National Stage entry from a PCT application. Providing this information in the application data sheet constitutes the specific reference required by 35 U.S. C. 119(e) or 120, and 37 CFR 1.78(a).

Corrected ADS 1.0

	Data of Record	Updated Data
Prior Application Status		
Application Number		
Continuity Type		
Prior Application Number		
Filing Date (YYYY-MM-DD)		
Patent Number		
Issue Date (YYYY-MM-DD)		

### Foreign Priority Information

**\*\*If no data is shown, no data has been corrected\*\***

This section allows for the applicant to claim priority to a foreign application. Providing this information in the application data sheet constitutes the claim for priority as required by 35 U.S.C. 119(b) and 37 CFR 1.55. When priority is claimed to a foreign application that is eligible for retrieval under the priority document exchange program (PDX) the information will be used by the Office to automatically attempt retrieval pursuant to 37 CFR 1.55(i)(1) and (2). Under the PDX program, applicant bears the ultimate responsibility for ensuring that a copy of the foreign application is received by the Office from the participating foreign intellectual property office, or a certified copy of the foreign priority application is filed, within the time period specified in 37 CFR 1.55(g)(1).

	Data of Record	Updated Data
Application Number		
Country		
Filing Date		
Access Code		

### Applicant Information

**\*\*If no data is shown, no data has been corrected\*\***

Providing assignment information in this section does not substitute for compliance with any requirement of part 3 of Title 37 of CFR to have an assignment recorded by the Office.

	Data of Record	Updated Data
Applicant Type		

If applicant is the legal representative, indicate the authority to file the patent application, the inventor is		
Name of the Deceased or Legally Incapacitated Inventor		
Applicant is an Organization		
Name		
Organization Name		
Address 1		
Address 2		
City,State/Province,Postal Code		
Country		
Phone Number		
Fax Number		
Email Address		

**Assignee Information including Non-Applicant Assignee Information**

**\*\*If no data is shown, no data has been corrected\*\***

Providing this information in the application data sheet does not substitute for compliance with any requirement of part 3 of Title 37 of the CFR to have an assignment recorded in the Office

	Data of Record	Updated Data
Order		
Applicant is an Organization		
Name		

Document Description: Application Data Sheet to update/correct info  
 Doc Code: ADS.CORR

Organization Name		
-------------------	--	--

<b>Mailing Address</b>		
Address 1		
Address 2		
City,State/Province,Postal Code		
Country		
Phone Number		
Fax Number		
Email Address		

## Signature

NOTE: This Application Data Sheet must be signed in accordance with 37 CFR 1.33(b).

This Application Data Sheet **must** be signed by a patent practitioner if one or more of the applicants is a **juristic entity** (e.g., corporation or association). If the applicant is two or more joint inventors, this form must be signed by a patent practitioner, **all** joint inventors who are the applicant, or one or more joint inventor-applicants who have been given power of attorney (e.g., see USPTO Form PTO/AIA/81) on behalf of **all** joint inventor-applicants.

See 37 CFR 1.4(d) for the manner of making signatures and certifications.

Signature	/Nicholas R. Transier/	Registration Number	68743
First Name	Nicholas	Last Name	TRANSIER



Under the Paperwork Reduction Act of 1995, no persons are required to respond to a collection of information unless it displays a valid OMB control number.

<b>SUBSTITUTE STATEMENT IN LIEU OF AN OATH OR DECLARATION FOR UTILITY OR DESIGN PATENT APPLICATION (35 U.S.C. 115(d) AND 37 CFR 1.64)</b>			
<b>Title of Invention</b>	Directed Wireless Communication		
This statement is directed to: <input type="checkbox"/> The attached application, OR <input checked="" type="checkbox"/> United States application or PCT international application number <u>13/855,410</u> filed on <u>04/02/2013</u> .			
<b>LEGAL NAME of inventor to whom this substitute statement applies:</b>			
(E.g., Given Name (first and middle (if any)) and Family Name or Surname) William J. Crilly, Jr.			
Residence (except for a deceased or legally incapacitated inventor):			
Liberty Lake City	WA State	United States of America Country	
Mailing Address (except for a deceased or legally incapacitated inventor):			
23825 E. 2nd Avenue Ct.			
Liberty Lake City	WA State	99019 Zip	United States of America Country
I believe the above-named inventor or joint inventor to be the original inventor or an original joint inventor of a claimed invention in the application.  The above-identified application was made or authorized to be made by me.  I hereby acknowledge that any willful false statement made in this statement is punishable under 18 U.S.C. 1001 by fine or imprisonment of not more than five (5) years, or both.			
Relationship to the inventor to whom this substitute statement applies:			
<input type="checkbox"/> Legal Representative (for deceased or legally incapacitated inventor only), <input checked="" type="checkbox"/> Assignee, <input type="checkbox"/> Person to whom the inventor is under an obligation to assign, <input type="checkbox"/> Person who otherwise shows a sufficient proprietary interest in the matter (petition under 37 CFR 1.46 is required), or <input type="checkbox"/> Joint Inventor.			

Under the Paperwork Reduction Act of 1995, no persons are required to respond to a collection of information unless it displays a valid OMB control number.

**SUBSTITUTE STATEMENT**

Circumstances permitting execution of this substitute statement:

- Inventor is deceased,
- Inventor is under legal incapacity,
- Inventor cannot be found or reached after diligent effort, or
- Inventor has refused to execute the oath or declaration under 37 CFR 1.63.

If there are joint inventors, please check the appropriate box below:

- An application data sheet under 37 CFR 1.76 (PTO/AIA/14 or equivalent) naming the entire inventive entity has been or is currently submitted.
- OR
- An application data sheet under 37 CFR 1.76 (PTO/AIA/14 or equivalent) has not been submitted. Thus, a Substitute Statement Supplemental Sheet (PTO/AIA/11 or equivalent) naming the entire inventive entity and providing inventor information is attached. See 37 CFR 1.64(b).

**WARNING:**

Petitioner/applicant is cautioned to avoid submitting personal information in documents filed in a patent application that may contribute to identity theft. Personal information such as social security numbers, bank account numbers, or credit card numbers (other than a check or credit card authorization form PTO-2038 submitted for payment purposes) is never required by the USPTO to support a petition or an application. If this type of personal information is included in documents submitted to the USPTO, petitioners/applicants should consider redacting such personal information from the documents before submitting them to the USPTO. Petitioner/applicant is advised that the record of a patent application is available to the public after publication of the application (unless a non-publication request in compliance with 37 CFR 1.213(a) is made in the application) or issuance of a patent. Furthermore, the record from an abandoned application may also be available to the public if the application is referenced in a published application or an issued patent (see 37 CFR 1.14). Checks and credit card authorization forms PTO-2038 submitted for payment purposes are not retained in the application file and therefore are not publicly available.

**PERSON EXECUTING THIS SUBSTITUTE STATEMENT:**

Name: Kai Hansen Date (Optional):

Signature:


**APPLICANT NAME AND TITLE OF PERSON EXECUTING THIS SUBSTITUTE STATEMENT:**

If the applicant is a juristic entity, list the applicant name and the title of the signer:

Applicant Name: XR Communications, LLC D/B/A Vivato Technologies

Title of Person Executing  
This Substitute Statement:

The signer, whose title is supplied above, is authorized to act on behalf of the applicant.

**Residence of the signer (unless provided in an application data sheet, PTO/AIA/14 or equivalent):**

San Diego	CA	United States of America
City	State	Country

**Mailing Address of the signer (unless provided in an application data sheet, PTO/AIA/14 or equivalent)**

6260 Sequence Drive; Suite 100

San Diego	CA	92121	United States of America
City	State	Zip	Country

Note: Use an additional PTO/AIA/02 form for each inventor who is deceased, legally incapacitated, cannot be found or reached after diligent effort, or has refused to execute the oath or declaration under 37 CFR 1.63.

**IN THE UNITED STATES PATENT AND TRADEMARK OFFICE**

Applicant: XR Communications, LLC D/B/A Vivato  
Technologies  
Application No.: 15/495,539  
Filing Date: April 24, 2017  
Title: DIRECTED WIRELESS COMMUNICATION  
Examiner: To be assigned  
Art Unit: To be assigned  
Confirmation No.: 1050

**GENERAL TRANSMITTAL**

Commissioner for Patents  
P.O. Box 1450  
Alexandria, VA 22313-1450

Dear Sir:

Applicant respectfully submits the following:

- Corrected ADS updating inventor name from William J. CRILLY to William J. CRILLY, JR.
- A copy of the Substitute Statement in Lieu of an Oath or Declaration for William J. CRILLY, JR., which was previously submitted with the original applications papers on April 24, 2017 at pages 3-4 of the Oath or Declaration document.
- The processing fee of \$70 as set forth in § 1.17(i).

Please charge any additional fees, including any fees for additional extension of time, or credit overpayment to Deposit Account No. 506237.

Respectfully submitted,  
EIP US LLP

Dated: April 27, 2017

By: / Nicholas R. Transier /  
Nicholas R. TRANSIER  
Registration No. 68,743  
Attorney of Record  
Customer No. 114581  
(619) 795-1300

## Electronic Patent Application Fee Transmittal

<b>Application Number:</b>	15495539			
<b>Filing Date:</b>				
<b>Title of Invention:</b>	DIRECTED WIRELESS COMMUNICATION			
<b>First Named Inventor/Applicant Name:</b>				
<b>Filer:</b>	Nicholas R. Transier/Jenny Stedman			
<b>Attorney Docket Number:</b>	E1027.800(T).US1D1C1C3			
Filed as Small Entity				
<b>Filing Fees for Utility under 35 USC 111(a)</b>				
<b>Description</b>	<b>Fee Code</b>	<b>Quantity</b>	<b>Amount</b>	<b>Sub-Total in USD(\$)</b>
<b>Basic Filing:</b>				
PROCESSING FEE, EXCEPT PROV. APPLS.	2830	1	70	70
<b>Pages:</b>				
<b>Claims:</b>				
<b>Miscellaneous-Filing:</b>				
<b>Petition:</b>				
<b>Patent-Appeals-and-Interference:</b>				
<b>Post-Allowance-and-Post-Issuance:</b>				

Description	Fee Code	Quantity	Amount	Sub-Total in USD(\$)
<b>Extension-of-Time:</b>				
<b>Miscellaneous:</b>				
<b>Total in USD (\$)</b>				<b>70</b>

## Electronic Acknowledgement Receipt

<b>EFS ID:</b>	29055642
<b>Application Number:</b>	15495539
<b>International Application Number:</b>	
<b>Confirmation Number:</b>	1050
<b>Title of Invention:</b>	DIRECTED WIRELESS COMMUNICATION
<b>First Named Inventor/Applicant Name:</b>	
<b>Customer Number:</b>	114581
<b>Filer:</b>	Nicholas R. Transier/Jenny Stedman
<b>Filer Authorized By:</b>	Nicholas R. Transier
<b>Attorney Docket Number:</b>	E1027.800(T).US1D1C1C3
<b>Receipt Date:</b>	27-APR-2017
<b>Filing Date:</b>	
<b>Time Stamp:</b>	19:56:52
<b>Application Type:</b>	Utility under 35 USC 111(a)

### Payment information:

Submitted with Payment	yes
Payment Type	CARD
Payment was successfully received in RAM	\$70
RAM confirmation Number	042817INTEFSW19565100
Deposit Account	
Authorized User	

The Director of the USPTO is hereby authorized to charge indicated fees and credit any overpayment as follows:

<b>File Listing:</b>					
<b>Document Number</b>	<b>Document Description</b>	<b>File Name</b>	<b>File Size(Bytes)/ Message Digest</b>	<b>Multi Part /.zip</b>	<b>Pages (if appl.)</b>
1	Application Data Sheet to update/ correct info	CorrectedADS.pdf	150800	no	14
			4846588ad5983df8943e701b076568775cc ffcea		
<b>Warnings:</b>					
<b>Information:</b>					
2	Oath or Declaration filed	Crilly_Declaration.pdf	409199	no	2
			58cba397c18d65b55a635cd505a4d7a691f b70e7		
<b>Warnings:</b>					
<b>Information:</b>					
3	Transmittal Letter	2017-04-27_Transmittal_C3.pdf	16840	no	1
			a7d4ea963dc35a26567c0a87c746cc24046 08e2b		
<b>Warnings:</b>					
<b>Information:</b>					
4	Fee Worksheet (SB06)	fee-info.pdf	30202	no	2
			6c8c9904aa8f649609edf65d01906fd060ad bbd5		
<b>Warnings:</b>					
<b>Information:</b>					
<b>Total Files Size (in bytes):</b>			607041		

**This Acknowledgement Receipt evidences receipt on the noted date by the USPTO of the indicated documents, characterized by the applicant, and including page counts, where applicable. It serves as evidence of receipt similar to a Post Card, as described in MPEP 503.**

**New Applications Under 35 U.S.C. 111**

**If a new application is being filed and the application includes the necessary components for a filing date (see 37 CFR 1.53(b)-(d) and MPEP 506), a Filing Receipt (37 CFR 1.54) will be issued in due course and the date shown on this Acknowledgement Receipt will establish the filing date of the application.**

**National Stage of an International Application under 35 U.S.C. 371**

**If a timely submission to enter the national stage of an international application is compliant with the conditions of 35 U.S.C. 371 and other applicable requirements a Form PCT/DO/EO/903 indicating acceptance of the application as a national stage submission under 35 U.S.C. 371 will be issued in addition to the Filing Receipt, in due course.**

**New International Application Filed with the USPTO as a Receiving Office**

**If a new international application is being filed and the international application includes the necessary components for an international filing date (see PCT Article 11 and MPEP 1810), a Notification of the International Application Number and of the International Filing Date (Form PCT/RO/105) will be issued in due course, subject to prescriptions concerning national security, and the date shown on this Acknowledgement Receipt will establish the international filing date of the application.**



**CERTIFICATION AND REQUEST FOR PRIORITIZED EXAMINATION  
 UNDER 37 CFR 1.102(e)** (Page 1 of 1)

First Named Inventor:	Marcus DA SILVA	Nonprovisional Application Number (if known):	
Title of Invention:	DIRECTED WIRELESS COMMUNICATION		

**APPLICANT HEREBY CERTIFIES THE FOLLOWING AND REQUESTS PRIORITIZED EXAMINATION FOR THE ABOVE-IDENTIFIED APPLICATION.**

1. The processing fee set forth in 37 CFR 1.17(i)(1) and the prioritized examination fee set forth in 37 CFR 1.17(c) have been filed with the request. The publication fee requirement is met because that fee, set forth in 37 CFR 1.18(d), is currently \$0. The basic filing fee, search fee, and examination fee are filed with the request or have been already been paid. I understand that any required excess claims fees or application size fee must be paid for the application.
2. I understand that the application may not contain, or be amended to contain, more than four independent claims, more than thirty total claims, or any multiple dependent claims, and that any request for an extension of time will cause an outstanding Track I request to be dismissed.

3. The applicable box is checked below:

**I.  Original Application (Track One) - Prioritized Examination under § 1.102(e)(1)**

- i. (a) The application is an original nonprovisional utility application filed under 35 U.S.C. 111(a). This certification and request is being filed with the utility application via EFS-Web.  
 ---OR---  
 (b) The application is an original nonprovisional plant application filed under 35 U.S.C. 111(a). This certification and request is being filed with the plant application in paper.
- ii. An executed inventor's oath or declaration under 37 CFR 1.63 or 37 CFR 1.64 for each inventor, or the application data sheet meeting the conditions specified in 37 CFR 1.53(f)(3)(i) is filed with the application.

**II.  Request for Continued Examination - Prioritized Examination under § 1.102(e)(2)**

- i. A request for continued examination has been filed with, or prior to, this form.
- ii. If the application is a utility application, this certification and request is being filed via EFS-Web.
- iii. The application is an original nonprovisional utility application filed under 35 U.S.C. 111(a), or is a national stage entry under 35 U.S.C. 371.
- iv. This certification and request is being filed prior to the mailing of a first Office action responsive to the request for continued examination.
- v. No prior request for continued examination has been granted prioritized examination status under 37 CFR 1.102(e)(2).

Signature /Nicholas R. Transier/	Date April 24, 2017
Name (Print/Typed) Nicholas R. TRANSIER	Practitioner Registration Number 68743

**Note:** This form must be signed in accordance with 37 CFR 1.33. See 37 CFR 1.4(d) for signature requirements and certifications. Submit multiple forms if more than one signature is required.\*

\*Total of 1 forms are submitted.

## Privacy Act Statement

The **Privacy Act of 1974 (P.L. 93-579)** requires that you be given certain information in connection with your submission of the attached form related to a patent application or patent. Accordingly, pursuant to the requirements of the Act, please be advised that: (1) the general authority for the collection of this information is 35 U.S.C. 2(b)(2); (2) furnishing of the information solicited is voluntary; and (3) the principal purpose for which the information is used by the U.S. Patent and Trademark Office is to process and/or examine your submission related to a patent application or patent. If you do not furnish the requested information, the U.S. Patent and Trademark Office may not be able to process and/or examine your submission, which may result in termination of proceedings or abandonment of the application or expiration of the patent.

The information provided by you in this form will be subject to the following routine uses:

1. The information on this form will be treated confidentially to the extent allowed under the Freedom of Information Act (5 U.S.C. 552) and the Privacy Act (5 U.S.C. 552a). Records from this system of records may be disclosed to the Department of Justice to determine whether disclosure of these records is required by the Freedom of Information Act.
2. A record from this system of records may be disclosed, as a routine use, in the course of presenting evidence to a court, magistrate, or administrative tribunal, including disclosures to opposing counsel in the course of settlement negotiations.
3. A record in this system of records may be disclosed, as a routine use, to a Member of Congress submitting a request involving an individual, to whom the record pertains, when the individual has requested assistance from the Member with respect to the subject matter of the record.
4. A record in this system of records may be disclosed, as a routine use, to a contractor of the Agency having need for the information in order to perform a contract. Recipients of information shall be required to comply with the requirements of the Privacy Act of 1974, as amended, pursuant to 5 U.S.C. 552a(m).
5. A record related to an International Application filed under the Patent Cooperation Treaty in this system of records may be disclosed, as a routine use, to the International Bureau of the World Intellectual Property Organization, pursuant to the Patent Cooperation Treaty.
6. A record in this system of records may be disclosed, as a routine use, to another federal agency for purposes of National Security review (35 U.S.C. 181) and for review pursuant to the Atomic Energy Act (42 U.S.C. 218(c)).
7. A record from this system of records may be disclosed, as a routine use, to the Administrator, General Services, or his/her designee, during an inspection of records conducted by GSA as part of that agency's responsibility to recommend improvements in records management practices and programs, under authority of 44 U.S.C. 2904 and 2906. Such disclosure shall be made in accordance with the GSA regulations governing inspection of records for this purpose, and any other relevant (*i.e.*, GSA or Commerce) directive. Such disclosure shall not be used to make determinations about individuals.
8. A record from this system of records may be disclosed, as a routine use, to the public after publication of the application pursuant to 35 U.S.C. 122(b) or issuance of a patent pursuant to 35 U.S.C. 151. Further, a record may be disclosed, subject to the limitations of 37 CFR 1.14, as a routine use, to the public if the record was filed in an application which became abandoned or in which the proceedings were terminated and which application is referenced by either a published application, an application open to public inspection or an issued patent.
9. A record from this system of records may be disclosed, as a routine use, to a Federal, State, or local law enforcement agency, if the USPTO becomes aware of a violation or potential violation of law or regulation.

Doc code: Oath  
 Document Description: Oath or declaration filed

PTO/AIA/02 (07-13)  
 Approved for use through 04/30/2017. OMB 0651-0032  
 U.S. Patent and Trademark Office; U.S. DEPARTMENT OF COMMERCE

Under the Paperwork Reduction Act of 1995, no persons are required to respond to a collection of information unless it displays a valid OMB control number.

<b>SUBSTITUTE STATEMENT IN LIEU OF AN OATH OR DECLARATION FOR UTILITY OR DESIGN PATENT APPLICATION (35 U.S.C. 115(d) AND 37 CFR 1.64)</b>			
<b>Title of Invention</b>	Directed Wireless Communication		
This statement is directed to: <input type="checkbox"/> The attached application, OR <input checked="" type="checkbox"/> United States application or PCT international application number <u>13/855,410</u> filed on <u>04/02/2013</u> .			
<b>LEGAL NAME of inventor to whom this substitute statement applies:</b>			
(E.g., Given Name (first and middle (if any)) and Family Name or Surname) Marcus Da Silva			
Residence (except for a deceased or legally incapacitated inventor):			
Spokane City	WA State	United States of America Country	
Mailing Address (except for a deceased or legally incapacitated inventor): 5510 East 25th			
Spokane City	WA State	99223 Zip	United States of America Country
I believe the above-named inventor or joint inventor to be the original inventor or an original joint inventor of a claimed invention in the application.  The above-identified application was made or authorized to be made by me.  I hereby acknowledge that any willful false statement made in this statement is punishable under 18 U.S.C. 1001 by fine or imprisonment of not more than five (5) years, or both.			
Relationship to the inventor to whom this substitute statement applies:			
<input type="checkbox"/> Legal Representative (for deceased or legally incapacitated inventor only), <input checked="" type="checkbox"/> Assignee, <input type="checkbox"/> Person to whom the inventor is under an obligation to assign, <input type="checkbox"/> Person who otherwise shows a sufficient proprietary interest in the matter (petition under 37 CFR 1.46 is required), or <input type="checkbox"/> Joint Inventor.			

**SUBSTITUTE STATEMENT**

Circumstances permitting execution of this substitute statement:

- Inventor is deceased,
- Inventor is under legal incapacity,
- Inventor cannot be found or reached after diligent effort, or
- Inventor has refused to execute the oath or declaration under 37 CFR 1.63.

If there are joint inventors, please check the appropriate box below:

- An application data sheet under 37 CFR 1.76 (PTO/AIA/14 or equivalent) naming the entire inventive entity has been or is currently submitted.

OR

- An application data sheet under 37 CFR 1.76 (PTO/AIA/14 or equivalent) has not been submitted. Thus, a Substitute Statement Supplemental Sheet (PTO/AIA/11 or equivalent) naming the entire inventive entity and providing inventor information is attached. See 37 CFR 1.64(b).

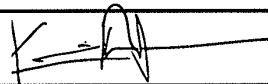
**WARNING:**

Petitioner/applicant is cautioned to avoid submitting personal information in documents filed in a patent application that may contribute to identity theft. Personal information such as social security numbers, bank account numbers, or credit card numbers (other than a check or credit card authorization form PTO-2038 submitted for payment purposes) is never required by the USPTO to support a petition or an application. If this type of personal information is included in documents submitted to the USPTO, petitioners/applicants should consider redacting such personal information from the documents before submitting them to the USPTO. Petitioner/applicant is advised that the record of a patent application is available to the public after publication of the application (unless a non-publication request in compliance with 37 CFR 1.213(a) is made in the application) or issuance of a patent. Furthermore, the record from an abandoned application may also be available to the public if the application is referenced in a published application or an issued patent (see 37 CFR 1.14). Checks and credit card authorization forms PTO-2038 submitted for payment purposes are not retained in the application file and therefore are not publicly available.

**PERSON EXECUTING THIS SUBSTITUTE STATEMENT:**

Name: Kai Hansen Date (Optional):

Signature:


**APPLICANT NAME AND TITLE OF PERSON EXECUTING THIS SUBSTITUTE STATEMENT:**

If the applicant is a juristic entity, list the applicant name and the title of the signer:

Applicant Name: XR Communications, LLC D/B/A Vivato Technologies

Title of Person Executing  
This Substitute Statement:

The signer, whose title is supplied above, is authorized to act on behalf of the applicant.

**Residence of the signer (unless provided in an application data sheet, PTO/AIA/14 or equivalent):**

City San Diego State CA Country United States of America

**Mailing Address of the signer (unless provided in an application data sheet, PTO/AIA/14 or equivalent)**

6260 Sequence Drive; Suite 100

City San Diego State CA Zip 92121 Country United States of America

Note: Use an additional PTO/AIA/02 form for each inventor who is deceased, legally incapacitated, cannot be found or reached after diligent effort, or has refused to execute the oath or declaration under 37 CFR 1.63.

Under the Paperwork Reduction Act of 1995, no persons are required to respond to a collection of information unless it displays a valid OMB control number.

<b>SUBSTITUTE STATEMENT IN LIEU OF AN OATH OR DECLARATION FOR UTILITY OR DESIGN PATENT APPLICATION (35 U.S.C. 115(d) AND 37 CFR 1.64)</b>			
<b>Title of Invention</b>	Directed Wireless Communication		
This statement is directed to:			
<input type="checkbox"/> The attached application, OR <input checked="" type="checkbox"/> United States application or PCT international application number <u>13/855,410</u> filed on <u>04/02/2013</u> .			
<b>LEGAL NAME of inventor to whom this substitute statement applies:</b>			
(E.g., Given Name (first and middle (if any)) and Family Name or Surname) William J. Crilly, Jr.			
Residence (except for a deceased or legally incapacitated inventor):			
Liberty Lake City	WA State	United States of America Country	
Mailing Address (except for a deceased or legally incapacitated inventor):			
23825 E. 2nd Avenue Ct.			
Liberty Lake City	WA State	99019 Zip	United States of America Country
I believe the above-named inventor or joint inventor to be the original inventor or an original joint inventor of a claimed invention in the application.			
The above-identified application was made or authorized to be made by me.			
I hereby acknowledge that any willful false statement made in this statement is punishable under 18 U.S.C. 1001 by fine or imprisonment of not more than five (5) years, or both.			
Relationship to the inventor to whom this substitute statement applies:			
<input type="checkbox"/> Legal Representative (for deceased or legally incapacitated inventor only), <input checked="" type="checkbox"/> Assignee, <input type="checkbox"/> Person to whom the inventor is under an obligation to assign, <input type="checkbox"/> Person who otherwise shows a sufficient proprietary interest in the matter (petition under 37 CFR 1.46 is required), or <input type="checkbox"/> Joint Inventor.			

Under the Paperwork Reduction Act of 1995, no persons are required to respond to a collection of information unless it displays a valid OMB control number.

**SUBSTITUTE STATEMENT**

Circumstances permitting execution of this substitute statement:

- Inventor is deceased,
- Inventor is under legal incapacity,
- Inventor cannot be found or reached after diligent effort, or
- Inventor has refused to execute the oath or declaration under 37 CFR 1.63.

If there are joint inventors, please check the appropriate box below:

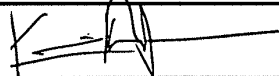
- An application data sheet under 37 CFR 1.76 (PTO/AIA/14 or equivalent) naming the entire inventive entity has been or is currently submitted.
- OR
- An application data sheet under 37 CFR 1.76 (PTO/AIA/14 or equivalent) has not been submitted. Thus, a Substitute Statement Supplemental Sheet (PTO/AIA/11 or equivalent) naming the entire inventive entity and providing inventor information is attached. See 37 CFR 1.64(b).

**WARNING:**

Petitioner/applicant is cautioned to avoid submitting personal information in documents filed in a patent application that may contribute to identity theft. Personal information such as social security numbers, bank account numbers, or credit card numbers (other than a check or credit card authorization form PTO-2038 submitted for payment purposes) is never required by the USPTO to support a petition or an application. If this type of personal information is included in documents submitted to the USPTO, petitioners/applicants should consider redacting such personal information from the documents before submitting them to the USPTO. Petitioner/applicant is advised that the record of a patent application is available to the public after publication of the application (unless a non-publication request in compliance with 37 CFR 1.213(a) is made in the application) or issuance of a patent. Furthermore, the record from an abandoned application may also be available to the public if the application is referenced in a published application or an issued patent (see 37 CFR 1.14). Checks and credit card authorization forms PTO-2038 submitted for payment purposes are not retained in the application file and therefore are not publicly available.

**PERSON EXECUTING THIS SUBSTITUTE STATEMENT:**

Name: Kai Hansen Date (Optional):

Signature: 

**APPLICANT NAME AND TITLE OF PERSON EXECUTING THIS SUBSTITUTE STATEMENT:**

If the applicant is a juristic entity, list the applicant name and the title of the signer:

Applicant Name: XR Communications, LLC D/B/A Vivato Technologies

Title of Person Executing This Substitute Statement:

The signer, whose title is supplied above, is authorized to act on behalf of the applicant.

**Residence of the signer (unless provided in an application data sheet, PTO/AIA/14 or equivalent):**

San Diego	CA	United States of America
City	State	Country

**Mailing Address of the signer (unless provided in an application data sheet, PTO/AIA/14 or equivalent)**

6260 Sequence Drive; Suite 100

San Diego	CA	92121	United States of America
City	State	Zip	Country

Note: Use an additional PTO/AIA/02 form for each inventor who is deceased, legally incapacitated, cannot be found or reached after diligent effort, or has refused to execute the oath or declaration under 37 CFR 1.63.

Under the Paperwork Reduction Act of 1995, no persons are required to respond to a collection of information unless it displays a valid OMB control number.

**DECLARATION (37 CFR 1.63) FOR UTILITY OR DESIGN APPLICATION USING AN APPLICATION DATA SHEET (37 CFR 1.76)**

Title of Invention

Directed Wireless Communication

As the below named inventor, I hereby declare that:

This declaration  The attached application, or  
is directed to:  United States application or PCT international application number 13/855,410  
filed on April 2, 2013.

The above-identified application was made or authorized to be made by me.

I believe that I am the original inventor or an original joint inventor of a claimed invention in the application.

I hereby acknowledge that any willful false statement made in this declaration is punishable under 18 U.S.C. 1001 by fine or imprisonment of not more than five (5) years, or both.

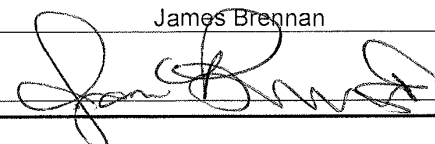
**WARNING:**

Petitioner/applicant is cautioned to avoid submitting personal information in documents filed in a patent application that may contribute to identity theft. Personal information such as social security numbers, bank account numbers, or credit card numbers (other than a check or credit card authorization form PTO-2038 submitted for payment purposes) is never required by the USPTO to support a petition or an application. If this type of personal information is included in documents submitted to the USPTO, petitioners/applicants should consider redacting such personal information from the documents before submitting them to the USPTO. Petitioner/applicant is advised that the record of a patent application is available to the public after publication of the application (unless a non-publication request in compliance with 37 CFR 1.213(a) is made in the application) or issuance of a patent. Furthermore, the record from an abandoned application may also be available to the public if the application is referenced in a published application or an issued patent (see 37 CFR 1.14). Checks and credit card authorization forms PTO-2038 submitted for payment purposes are not retained in the application file and therefore are not publicly available.

LEGAL NAME OF INVENTOR

Inventor: James Brennan

Date (Optional): Nov. 5, 2015

Signature: 

Note: An application data sheet (PTO/SB/14 or equivalent), including naming the entire inventive entity, must accompany this form or must have been previously filed. Use an additional PTO/AIA/01 form for each additional inventor.

Under the Paperwork Reduction Act of 1995, no persons are required to respond to a collection of information unless it displays a valid OMB control number.

<b>SUBSTITUTE STATEMENT IN LIEU OF AN OATH OR DECLARATION FOR UTILITY OR DESIGN PATENT APPLICATION (35 U.S.C. 115(d) AND 37 CFR 1.64)</b>			
<b>Title of Invention</b>	Directed Wireless Communication		
This statement is directed to: <input type="checkbox"/> The attached application, OR <input checked="" type="checkbox"/> United States application or PCT international application number <u>13/855,410</u> filed on <u>04/02/2013</u> .			
<b>LEGAL NAME of inventor to whom this substitute statement applies:</b>			
(E.g., Given Name (first and middle (if any)) and Family Name or Surname) <div style="text-align: center;">Robert J. Conley</div>			
Residence (except for a deceased or legally incapacitated inventor):			
Liberty Lake City	WA State	United States of America Country	
Mailing Address (except for a deceased or legally incapacitated inventor):			
23326 E. 2nd Avenue			
Liberty Lake City	WA State	99019 Zip	United States of America Country
I believe the above-named inventor or joint inventor to be the original inventor or an original joint inventor of a claimed invention in the application.  The above-identified application was made or authorized to be made by me.  I hereby acknowledge that any willful false statement made in this statement is punishable under 18 U.S.C. 1001 by fine or imprisonment of not more than five (5) years, or both.			
Relationship to the inventor to whom this substitute statement applies:			
<input type="checkbox"/> Legal Representative (for deceased or legally incapacitated inventor only), <input checked="" type="checkbox"/> Assignee, <input type="checkbox"/> Person to whom the inventor is under an obligation to assign, <input type="checkbox"/> Person who otherwise shows a sufficient proprietary interest in the matter (petition under 37 CFR 1.46 is required), or <input type="checkbox"/> Joint Inventor.			



Under the Paperwork Reduction Act of 1995, no persons are required to respond to a collection of information unless it displays a valid OMB control number.

**SUBSTITUTE STATEMENT**

Circumstances permitting execution of this substitute statement:

- Inventor is deceased,
- Inventor is under legal incapacity,
- Inventor cannot be found or reached after diligent effort, or
- Inventor has refused to execute the oath or declaration under 37 CFR 1.63.

If there are joint inventors, please check the appropriate box below:

- An application data sheet under 37 CFR 1.76 (PTO/AIA/14 or equivalent) naming the entire inventive entity has been or is currently submitted.

OR

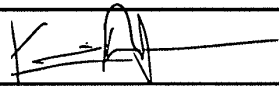
- An application data sheet under 37 CFR 1.76 (PTO/AIA/14 or equivalent) has not been submitted. Thus, a Substitute Statement Supplemental Sheet (PTO/AIA/11 or equivalent) naming the entire inventive entity and providing inventor information is attached. See 37 CFR 1.64(b).

**WARNING:**

Petitioner/applicant is cautioned to avoid submitting personal information in documents filed in a patent application that may contribute to identity theft. Personal information such as social security numbers, bank account numbers, or credit card numbers (other than a check or credit card authorization form PTO-2038 submitted for payment purposes) is never required by the USPTO to support a petition or an application. If this type of personal information is included in documents submitted to the USPTO, petitioners/applicants should consider redacting such personal information from the documents before submitting them to the USPTO. Petitioner/applicant is advised that the record of a patent application is available to the public after publication of the application (unless a non-publication request in compliance with 37 CFR 1.213(a) is made in the application) or issuance of a patent. Furthermore, the record from an abandoned application may also be available to the public if the application is referenced in a published application or an issued patent (see 37 CFR 1.14). Checks and credit card authorization forms PTO-2038 submitted for payment purposes are not retained in the application file and therefore are not publicly available.

**PERSON EXECUTING THIS SUBSTITUTE STATEMENT:**

Name: Kai Hansen Date (Optional):

Signature: **APPLICANT NAME AND TITLE OF PERSON EXECUTING THIS SUBSTITUTE STATEMENT:**

If the applicant is a juristic entity, list the applicant name and the title of the signer:

Applicant Name: XR Communications, LLC D/B/A Vivato Technologies

Title of Person Executing  
This Substitute Statement:

The signer, whose title is supplied above, is authorized to act on behalf of the applicant.

**Residence of the signer (unless provided in an application data sheet, PTO/AIA/14 or equivalent):**

City San Diego State CA Country United States of America

**Mailing Address of the signer (unless provided in an application data sheet, PTO/AIA/14 or equivalent)**

6260 Sequence Drive; Suite 100

City San Diego State CA Zip 92121 Country United States of America

Note: Use an additional PTO/AIA/02 form for each inventor who is deceased, legally incapacitated, cannot be found or reached after diligent effort, or has refused to execute the oath or declaration under 37 CFR 1.63.

Under the Paperwork Reduction Act of 1995, no persons are required to respond to a collection of information unless it displays a valid OMB control number.

<b>SUBSTITUTE STATEMENT IN LIEU OF AN OATH OR DECLARATION FOR UTILITY OR DESIGN PATENT APPLICATION (35 U.S.C. 115(d) AND 37 CFR 1.64)</b>			
<b>Title of Invention</b>	Directed Wireless Communication		
This statement is directed to:			
<input type="checkbox"/> The attached application,			
OR			
<input checked="" type="checkbox"/> United States application or PCT international application number <u>13/855,410</u> filed on <u>04/02/2013</u> .			
<b>LEGAL NAME of inventor to whom this substitute statement applies:</b>			
(E.g., Given Name (first and middle (if any)) and Family Name or Surname)			
Siavash Alamouti			
Residence (except for a deceased or legally incapacitated inventor):			
Spokane	WA	United States of America	
City	State	Country	
Mailing Address (except for a deceased or legally incapacitated inventor):			
2123 West 1st Ave., Apt 3			
Spokane	WA	99204	United States of America
City	State	Zip	Country
I believe the above-named inventor or joint inventor to be the original inventor or an original joint inventor of a claimed invention in the application.			
The above-identified application was made or authorized to be made by me.			
I hereby acknowledge that any willful false statement made in this statement is punishable under 18 U.S.C. 1001 by fine or imprisonment of not more than five (5) years, or both.			
Relationship to the inventor to whom this substitute statement applies:			
<input type="checkbox"/> Legal Representative (for deceased or legally incapacitated inventor only),			
<input checked="" type="checkbox"/> Assignee,			
<input type="checkbox"/> Person to whom the inventor is under an obligation to assign,			
<input type="checkbox"/> Person who otherwise shows a sufficient proprietary interest in the matter (petition under 37 CFR 1.46 is required), or			
<input type="checkbox"/> Joint Inventor.			

Under the Paperwork Reduction Act of 1995, no persons are required to respond to a collection of information unless it displays a valid OMB control number.

**SUBSTITUTE STATEMENT**

Circumstances permitting execution of this substitute statement:

- Inventor is deceased,
- Inventor is under legal incapacity,
- Inventor cannot be found or reached after diligent effort, or
- Inventor has refused to execute the oath or declaration under 37 CFR 1.63.

If there are joint inventors, please check the appropriate box below:

- An application data sheet under 37 CFR 1.76 (PTO/AIA/14 or equivalent) naming the entire inventive entity has been or is currently submitted.

OR

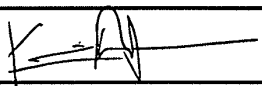
- An application data sheet under 37 CFR 1.76 (PTO/AIA/14 or equivalent) has not been submitted. Thus, a Substitute Statement Supplemental Sheet (PTO/AIA/11 or equivalent) naming the entire inventive entity and providing inventor information is attached. See 37 CFR 1.64(b).

**WARNING:**

Petitioner/applicant is cautioned to avoid submitting personal information in documents filed in a patent application that may contribute to identity theft. Personal information such as social security numbers, bank account numbers, or credit card numbers (other than a check or credit card authorization form PTO-2038 submitted for payment purposes) is never required by the USPTO to support a petition or an application. If this type of personal information is included in documents submitted to the USPTO, petitioners/applicants should consider redacting such personal information from the documents before submitting them to the USPTO. Petitioner/applicant is advised that the record of a patent application is available to the public after publication of the application (unless a non-publication request in compliance with 37 CFR 1.213(a) is made in the application) or issuance of a patent. Furthermore, the record from an abandoned application may also be available to the public if the application is referenced in a published application or an issued patent (see 37 CFR 1.14). Checks and credit card authorization forms PTO-2038 submitted for payment purposes are not retained in the application file and therefore are not publicly available.

**PERSON EXECUTING THIS SUBSTITUTE STATEMENT:**

Name: Kai Hansen Date (Optional):

Signature: **APPLICANT NAME AND TITLE OF PERSON EXECUTING THIS SUBSTITUTE STATEMENT:**

If the applicant is a juristic entity, list the applicant name and the title of the signer:

Applicant Name: XR Communications, LLC D/B/A Vivato Technologies

Title of Person Executing  
This Substitute Statement:

The signer, whose title is supplied above, is authorized to act on behalf of the applicant.

**Residence of the signer (unless provided in an application data sheet, PTO/AIA/14 or equivalent):**

City San Diego State CA Country United States of America

**Mailing Address of the signer (unless provided in an application data sheet, PTO/AIA/14 or equivalent)**

6260 Sequence Drive; Suite 100

City San Diego State CA Zip 92121 Country United States of America

Note: Use an additional PTO/AIA/02 form for each inventor who is deceased, legally incapacitated, cannot be found or reached after diligent effort, or has refused to execute the oath or declaration under 37 CFR 1.63.

Doc code: Oath  
Document Description: Oath or declaration filed

PTO/AIA/02 (07-13)  
Approved for use through 04/30/2017. OMB 0651-0032  
U.S. Patent and Trademark Office; U.S. DEPARTMENT OF COMMERCE

Under the Paperwork Reduction Act of 1995, no persons are required to respond to a collection of information unless it displays a valid OMB control number.

<b>SUBSTITUTE STATEMENT IN LIEU OF AN OATH OR DECLARATION FOR UTILITY OR DESIGN PATENT APPLICATION (35 U.S.C. 115(d) AND 37 CFR 1.64)</b>			
<b>Title of Invention</b>	Directed Wireless Communication		
This statement is directed to:			
<input type="checkbox"/> The attached application,			
OR			
<input checked="" type="checkbox"/> United States application or PCT international application number <u>13/855,410</u> filed on <u>04/02/2013</u> .			
<b>LEGAL NAME of inventor to whom this substitute statement applies:</b>			
(E.g., Given Name (first and middle (if any)) and Family Name or Surname)			
Eduardo Casas			
Residence (except for a deceased or legally incapacitated inventor):			
Vancouver	BC	Canada	
City	State	Country	
Mailing Address (except for a deceased or legally incapacitated inventor):			
7542 Ontario Street			
Vancouver		V5X3C2	Canada
City	State	Zip	Country
I believe the above-named inventor or joint inventor to be the original inventor or an original joint inventor of a claimed invention in the application.			
The above-identified application was made or authorized to be made by me.			
I hereby acknowledge that any willful false statement made in this statement is punishable under 18 U.S.C. 1001 by fine or imprisonment of not more than five (5) years, or both.			
Relationship to the inventor to whom this substitute statement applies:			
<input type="checkbox"/> Legal Representative (for deceased or legally incapacitated inventor only),			
<input checked="" type="checkbox"/> Assignee,			
<input type="checkbox"/> Person to whom the inventor is under an obligation to assign,			
<input type="checkbox"/> Person who otherwise shows a sufficient proprietary interest in the matter (petition under 37 CFR 1.46 is required), or			
<input type="checkbox"/> Joint Inventor.			

### SUBSTITUTE STATEMENT

Circumstances permitting execution of this substitute statement:

- Inventor is deceased,
- Inventor is under legal incapacity,
- Inventor cannot be found or reached after diligent effort, or
- Inventor has refused to execute the oath or declaration under 37 CFR 1.63.

If there are joint inventors, please check the appropriate box below:

- An application data sheet under 37 CFR 1.76 (PTO/AIA/14 or equivalent) naming the entire inventive entity has been or is currently submitted.

OR


- An application data sheet under 37 CFR 1.76 (PTO/AIA/14 or equivalent) has not been submitted. Thus, a Substitute Statement Supplemental Sheet (PTO/AIA/11 or equivalent) naming the entire inventive entity and providing inventor information is attached. See 37 CFR 1.64(b).

#### WARNING:

Petitioner/applicant is cautioned to avoid submitting personal information in documents filed in a patent application that may contribute to identity theft. Personal information such as social security numbers, bank account numbers, or credit card numbers (other than a check or credit card authorization form PTO-2038 submitted for payment purposes) is never required by the USPTO to support a petition or an application. If this type of personal information is included in documents submitted to the USPTO, petitioners/applicants should consider redacting such personal information from the documents before submitting them to the USPTO. Petitioner/applicant is advised that the record of a patent application is available to the public after publication of the application (unless a non-publication request in compliance with 37 CFR 1.213(a) is made in the application) or issuance of a patent. Furthermore, the record from an abandoned application may also be available to the public if the application is referenced in a published application or an issued patent (see 37 CFR 1.14). Checks and credit card authorization forms PTO-2038 submitted for payment purposes are not retained in the application file and therefore are not publicly available.

#### PERSON EXECUTING THIS SUBSTITUTE STATEMENT:

Name: Kai Hansen	Date (Optional):
------------------	------------------

Signature: 

#### APPLICANT NAME AND TITLE OF PERSON EXECUTING THIS SUBSTITUTE STATEMENT:

If the applicant is a juristic entity, list the applicant name and the title of the signer:

Applicant Name: XR Communications, LLC D/B/A Vivato Technologies

Title of Person Executing This Substitute Statement:

The signer, whose title is supplied above, is authorized to act on behalf of the applicant.

#### Residence of the signer (unless provided in an application data sheet, PTO/AIA/14 or equivalent):

City San Diego	State CA	Country United States of America
-------------------	-------------	-------------------------------------

#### Mailing Address of the signer (unless provided in an application data sheet, PTO/AIA/14 or equivalent)

6260 Sequence Drive; Suite 100

City San Diego	State CA	Zip 92121	Country United States of America
-------------------	-------------	--------------	-------------------------------------

Note: Use an additional PTO/AIA/02 form for each inventor who is deceased, legally incapacitated, cannot be found or reached after diligent effort, or has refused to execute the oath or declaration under 37 CFR 1.63.

Under the Paperwork Reduction Act of 1995, no persons are required to respond to a collection of information unless it displays a valid OMB control number.

<b>SUBSTITUTE STATEMENT IN LIEU OF AN OATH OR DECLARATION FOR UTILITY OR DESIGN PATENT APPLICATION (35 U.S.C. 115(d) AND 37 CFR 1.64)</b>			
<b>Title of Invention</b>	Directed Wireless Communication		
This statement is directed to: <input type="checkbox"/> The attached application, OR <input checked="" type="checkbox"/> United States application or PCT international application number <u>13/855,410</u> filed on <u>04/02/2013</u> .			
<b>LEGAL NAME of inventor to whom this substitute statement applies:</b>			
(E.g., Given Name (first and middle (if any)) and Family Name or Surname) <div style="text-align: center;">Hujun Yin</div>			
Residence (except for a deceased or legally incapacitated inventor):			
City Spokane	State WA	Country United States of America	
Mailing Address (except for a deceased or legally incapacitated inventor): 2415 N. Cherry Street, Apt. 23			
City Spokane	State WA	Zip 99216	Country United States of America
I believe the above-named inventor or joint inventor to be the original inventor or an original joint inventor of a claimed invention in the application.  The above-identified application was made or authorized to be made by me.  I hereby acknowledge that any willful false statement made in this statement is punishable under 18 U.S.C. 1001 by fine or imprisonment of not more than five (5) years, or both.			
Relationship to the inventor to whom this substitute statement applies:			
<input type="checkbox"/> Legal Representative (for deceased or legally incapacitated inventor only), <input checked="" type="checkbox"/> Assignee, <input type="checkbox"/> Person to whom the inventor is under an obligation to assign, <input type="checkbox"/> Person who otherwise shows a sufficient proprietary interest in the matter (petition under 37 CFR 1.46 is required), or <input type="checkbox"/> Joint Inventor.			

Under the Paperwork Reduction Act of 1995, no persons are required to respond to a collection of information unless it displays a valid OMB control number.

**SUBSTITUTE STATEMENT**

Circumstances permitting execution of this substitute statement:

- Inventor is deceased,
- Inventor is under legal incapacity,
- Inventor cannot be found or reached after diligent effort, or
- Inventor has refused to execute the oath or declaration under 37 CFR 1.63.

If there are joint inventors, please check the appropriate box below:

- An application data sheet under 37 CFR 1.76 (PTO/AIA/14 or equivalent) naming the entire inventive entity has been or is currently submitted.

OR

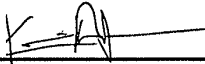
- An application data sheet under 37 CFR 1.76 (PTO/AIA/14 or equivalent) has not been submitted. Thus, a Substitute Statement Supplemental Sheet (PTO/AIA/11 or equivalent) naming the entire inventive entity and providing inventor information is attached. See 37 CFR 1.64(b).

**WARNING:**

Petitioner/applicant is cautioned to avoid submitting personal information in documents filed in a patent application that may contribute to identity theft. Personal information such as social security numbers, bank account numbers, or credit card numbers (other than a check or credit card authorization form PTO-2038 submitted for payment purposes) is never required by the USPTO to support a petition or an application. If this type of personal information is included in documents submitted to the USPTO, petitioners/applicants should consider redacting such personal information from the documents before submitting them to the USPTO. Petitioner/applicant is advised that the record of a patent application is available to the public after publication of the application (unless a non-publication request in compliance with 37 CFR 1.213(a) is made in the application) or issuance of a patent. Furthermore, the record from an abandoned application may also be available to the public if the application is referenced in a published application or an issued patent (see 37 CFR 1.14). Checks and credit card authorization forms PTO-2038 submitted for payment purposes are not retained in the application file and therefore are not publicly available.

**PERSON EXECUTING THIS SUBSTITUTE STATEMENT:**

Name: Kai Hansen Date (Optional):

Signature: **APPLICANT NAME AND TITLE OF PERSON EXECUTING THIS SUBSTITUTE STATEMENT:**

If the applicant is a juristic entity, list the applicant name and the title of the signer:

Applicant Name: XR Communications, LLC D/B/A Vivato Technologies

Title of Person Executing This Substitute Statement:

The signer, whose title is supplied above, is authorized to act on behalf of the applicant.

**Residence of the signer (unless provided in an application data sheet, PTO/AIA/14 or equivalent):**

City San Diego State CA Country United States of America

**Mailing Address of the signer (unless provided in an application data sheet, PTO/AIA/14 or equivalent)**


6260 Sequence Drive; Suite 100

City San Diego State CA Zip 92121 Country United States of America

Note: Use an additional PTO/AIA/02 form for each inventor who is deceased, legally incapacitated, cannot be found or reached after diligent effort, or has refused to execute the oath or declaration under 37 CFR 1.63.

Under the Paperwork Reduction Act of 1995, no persons are required to respond to a collection of information unless it displays a valid OMB control number.

**DECLARATION (37 CFR 1.63) FOR UTILITY OR DESIGN APPLICATION USING AN  
APPLICATION DATA SHEET (37 CFR 1.76)**

<b>Title of Invention</b>	Directed Wireless Communication
<p>As the below named inventor, I hereby declare that:</p> <p>This declaration <input type="checkbox"/> The attached application, or is directed to: <input checked="" type="checkbox"/> United States application or PCT international application number <u>13/855,410</u> filed on <u>April 2, 2013</u>.</p> <p>The above-identified application was made or authorized to be made by me.</p> <p>I believe that I am the original inventor or an original joint inventor of a claimed invention in the application.</p> <p>I hereby acknowledge that any willful false statement made in this declaration is punishable under 18 U.S.C. 1001 by fine or imprisonment of not more than five (5) years, or both.</p> <p align="center"><b>WARNING:</b></p> <p>Petitioner/applicant is cautioned to avoid submitting personal information in documents filed in a patent application that may contribute to identity theft. Personal information such as social security numbers, bank account numbers, or credit card numbers (other than a check or credit card authorization form PTO-2038 submitted for payment purposes) is never required by the USPTO to support a petition or an application. If this type of personal information is included in documents submitted to the USPTO, petitioners/applicants should consider redacting such personal information from the documents before submitting them to the USPTO. Petitioner/applicant is advised that the record of a patent application is available to the public after publication of the application (unless a non-publication request in compliance with 37 CFR 1.213(a) is made in the application) or issuance of a patent. Furthermore, the record from an abandoned application may also be available to the public if the application is referenced in a published application or an issued patent (see 37 CFR 1.14). Checks and credit card authorization forms PTO-2038 submitted for payment purposes are not retained in the application file and therefore are not publicly available.</p>	
<b>LEGAL NAME OF INVENTOR</b>	
Inventor: <u></u>	Bobby Jose
Signature: _____	Date (Optional): <u>21 NOV 2015</u>
<p>Note: An application data sheet (PTO/SB/14 or equivalent), including naming the entire inventive entity, must accompany this form or must have been previously filed. Use an additional PTO/AIA/01 form for each additional inventor.</p>	



Under the Paperwork Reduction Act of 1995, no persons are required to respond to a collection of information unless it displays a valid OMB control number.

**DECLARATION (37 CFR 1.63) FOR UTILITY OR DESIGN APPLICATION USING AN  
APPLICATION DATA SHEET (37 CFR 1.76)**

<b>Title of Invention</b>	Directed Wireless Communication
-------------------------------	---------------------------------

As the below named inventor, I hereby declare that:

This declaration  The attached application, or  
is directed to:  United States application or PCT international application number 13/855,410  
filed on April 2, 2013.

The above-identified application was made or authorized to be made by me.

I believe that I am the original inventor or an original joint inventor of a claimed invention in the application.

I hereby acknowledge that any willful false statement made in this declaration is punishable under 18 U.S.C. 1001 by fine or imprisonment of not more than five (5) years, or both.

**WARNING:**

Petitioner/applicant is cautioned to avoid submitting personal information in documents filed in a patent application that may contribute to identity theft. Personal information such as social security numbers, bank account numbers, or credit card numbers (other than a check or credit card authorization form PTO-2038 submitted for payment purposes) is never required by the USPTO to support a petition or an application. If this type of personal information is included in documents submitted to the USPTO, petitioners/applicants should consider redacting such personal information from the documents before submitting them to the USPTO. Petitioner/applicant is advised that the record of a patent application is available to the public after publication of the application (unless a non-publication request in compliance with 37 CFR 1.213(a) is made in the application) or issuance of a patent. Furthermore, the record from an abandoned application may also be available to the public if the application is referenced in a published application or an issued patent (see 37 CFR 1.14). Checks and credit card authorization forms PTO-2038 submitted for payment purposes are not retained in the application file and therefore are not publicly available.

**LEGAL NAME OF INVENTOR**


Inventor: Yang-Seok Choi Date (Optional): \_\_\_\_\_

Signature:  \_\_\_\_\_

Note: An application data sheet (PTO/SB/14 or equivalent), including naming the entire inventive entity, must accompany this form or must have been previously filed. Use an additional PTO/AIA/01 form for each additional inventor.

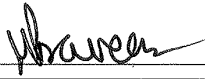
Under the Paperwork Reduction Act of 1995, no persons are required to respond to a collection of information unless it displays a valid OMB control number.

**DECLARATION (37 CFR 1.63) FOR UTILITY OR DESIGN APPLICATION USING AN  
APPLICATION DATA SHEET (37 CFR 1.76)**

<b>Title of Invention</b>	Directed Wireless Communication
<p>As the below named inventor, I hereby declare that:</p> <p>This declaration <input type="checkbox"/> The attached application, or is directed to: <input checked="" type="checkbox"/> United States application or PCT international application number <u>13/855,410</u> filed on <u>April 2, 2013</u>.</p> <p>The above-identified application was made or authorized to be made by me.</p> <p>I believe that I am the original inventor or an original joint inventor of a claimed invention in the application.</p> <p>I hereby acknowledge that any willful false statement made in this declaration is punishable under 18 U.S.C. 1001 by fine or imprisonment of not more than five (5) years, or both.</p> <p align="center"><b>WARNING:</b></p> <p>Petitioner/applicant is cautioned to avoid submitting personal information in documents filed in a patent application that may contribute to identity theft. Personal information such as social security numbers, bank account numbers, or credit card numbers (other than a check or credit card authorization form PTO-2038 submitted for payment purposes) is never required by the USPTO to support a petition or an application. If this type of personal information is included in documents submitted to the USPTO, petitioners/applicants should consider redacting such personal information from the documents before submitting them to the USPTO. Petitioner/applicant is advised that the record of a patent application is available to the public after publication of the application (unless a non-publication request in compliance with 37 CFR 1.213(a) is made in the application) or issuance of a patent. Furthermore, the record from an abandoned application may also be available to the public if the application is referenced in a published application or an issued patent (see 37 CFR 1.14). Checks and credit card authorization forms PTO-2038 submitted for payment purposes are not retained in the application file and therefore are not publicly available.</p>	
<b>LEGAL NAME OF INVENTOR</b>	
Inventor: <u>Vahid Tarokh</u>	Date (Optional): <u>11/02/2015</u>
Signature: 	
<p>Note: An application data sheet (PTO/SB/14 or equivalent), including naming the entire inventive entity, must accompany this form or must have been previously filed. Use an additional PTO/AIA/01 form for each additional inventor.</p>	

Under the Paperwork Reduction Act of 1995, no persons are required to respond to a collection of information unless it displays a valid OMB control number.

**DECLARATION (37 CFR 1.63) FOR UTILITY OR DESIGN APPLICATION USING AN  
APPLICATION DATA SHEET (37 CFR 1.76)**

<b>Title of Invention</b>	Directed Wireless Communication
<p>As the below named inventor, I hereby declare that:</p> <p>This declaration <input type="checkbox"/> The attached application, or is directed to: <input checked="" type="checkbox"/> United States application or PCT international application number <u>13/855,410</u> filed on <u>April 2, 2013</u>.</p> <p>The above-identified application was made or authorized to be made by me.</p> <p>I believe that I am the original inventor or an original joint inventor of a claimed invention in the application.</p> <p>I hereby acknowledge that any willful false statement made in this declaration is punishable under 18 U.S.C. 1001 by fine or imprisonment of not more than five (5) years, or both.</p> <p align="center"><b>WARNING:</b></p> <p>Petitioner/applicant is cautioned to avoid submitting personal information in documents filed in a patent application that may contribute to identity theft. Personal information such as social security numbers, bank account numbers, or credit card numbers (other than a check or credit card authorization form PTO-2038 submitted for payment purposes) is never required by the USPTO to support a petition or an application. If this type of personal information is included in documents submitted to the USPTO, petitioners/applicants should consider redacting such personal information from the documents before submitting them to the USPTO. Petitioner/applicant is advised that the record of a patent application is available to the public after publication of the application (unless a non-publication request in compliance with 37 CFR 1.213(a) is made in the application) or issuance of a patent. Furthermore, the record from an abandoned application may also be available to the public if the application is referenced in a published application or an issued patent (see 37 CFR 1.14). Checks and credit card authorization forms PTO-2038 submitted for payment purposes are not retained in the application file and therefore are not publicly available.</p>	
<p><b>LEGAL NAME OF INVENTOR</b></p> <p>Inventor: <u>Praveen Mehrotra</u> Date (Optional): <u>11/05/2015</u></p> <p>Signature: <u></u></p>	
<p>Note: An application data sheet (PTO/SB/14 or equivalent), including naming the entire inventive entity, must accompany this form or must have been previously filed. Use an additional PTO/AIA/01 form for each additional inventor.</p>	

## TRANSMITTAL FOR POWER OF ATTORNEY TO ONE OR MORE REGISTERED PRACTITIONERS

NOTE: This form is to be submitted with the Power of Attorney by Applicant form (PTO/AIA/82B) to identify the application to which the Power of Attorney is directed, in accordance with 37 CFR 1.5, unless the application number and filing date are identified in the Power of Attorney by Applicant form. If neither form PTO/AIA/82A nor form PTO/AIA82B identifies the application to which the Power of Attorney is directed, the Power of Attorney will not be recognized in the application.

Application Number	
Filing Date	Herewith
First Named Inventor	Marcus DA SILVA
Title	Directed Wireless Communication
Art Unit	TBD
Examiner Name	TBD
Attorney Docket Number	E1027.800(T).US1D1C1C3

SIGNATURE of Applicant or Patent Practitioner			
Signature	/Nicholas R. Transier/	Date (Optional)	
Name	Nicholas R. TRANSIER	Registration Number	68743
Title (if Applicant is a juristic entity)	Attorney of Record		
Applicant Name (if Applicant is a juristic entity)	XR Communications, LLC D/B/A Vivato Technologies		

**NOTE:** This form must be signed in accordance with 37 CFR 1.33. See 37 CFR 1.4(d) for signature requirements and certifications. If more than one applicant, use multiple forms.

\*Total of 1 forms are submitted.

This collection of information is required by 37 CFR 1.131, 1.32, and 1.33. The information is required to obtain or retain a benefit by the public which is to file (and by the USPTO to process) an application. Confidentiality is governed by 35 U.S.C. 122 and 37 CFR 1.11 and 1.14. This collection is estimated to take 3 minutes to complete, including gathering, preparing, and submitting the completed application form to the USPTO. Time will vary depending upon the individual case. Any comments on the amount of time you require to complete this form and/or suggestions for reducing this burden, should be sent to the Chief Information Officer, U.S. Patent and Trademark Office, U.S. Department of Commerce, P.O. Box 1450, Alexandria, VA 22313-1450. DO NOT SEND FEES OR COMPLETED FORMS TO THIS ADDRESS. **SEND TO: Commissioner for Patents, P.O. Box 1450, Alexandria, VA 22313-1450.**

*If you need assistance in completing the form, call 1-800-PTO-9199 and select option 2.*

## POWER OF ATTORNEY BY APPLICANT

I hereby revoke all previous powers of attorney given in the application identified in either the attached transmittal letter or the boxes below.

Application Number	Filing Date

(Note: The boxes above may be left blank if information is provided on form PTO/AIA/82A.)

- I hereby appoint the Patent Practitioner(s) associated with the following Customer Number as my/our attorney(s) or agent(s), and to transact all business in the United States Patent and Trademark Office connected therewith for the application referenced in the attached transmittal letter (form PTO/AIA/82A) or identified above:
- 114581
- OR
- I hereby appoint Practitioner(s) named in the attached list (form PTO/AIA/82C) as my/our attorney(s) or agent(s), and to transact all business in the United States Patent and Trademark Office connected therewith for the patent application referenced in the attached transmittal letter (form PTO/AIA/82A) or identified above. (Note: Complete form PTO/AIA/82C.)

Please recognize or change the correspondence address for the application identified in the attached transmittal letter or the boxes above to:

- The address associated with the above-mentioned Customer Number
- OR
- The address associated with Customer Number: \_\_\_\_\_
- OR

Firm or Individual Name				
Address				
City	State	Zip		
Country				
Telephone	Email			

I am the Applicant (if the Applicant is a juristic entity, list the Applicant name in the box)

XR Communications, LLC D/B/A Vivato Technologies

- Inventor or Joint Inventor (title not required below)
- Legal Representative of a Deceased or Legally Incapacitated Inventor (title not required below)
- Assignee or Person to Whom the Inventor is Under an Obligation to Assign (provide signer's title if applicant is a juristic entity)
- Person Who Otherwise Shows Sufficient Proprietary Interest (e.g., a petition under 37 CFR 1.46(b)(2) was granted in the application or is concurrently being filed with this document) (provide signer's title if applicant is a juristic entity)

**SIGNATURE of Applicant for Patent**

The undersigned (whose title is supplied below) is authorized to act on behalf of the applicant (e.g., where the applicant is a juristic entity).

Signature	Date (Optional)	1-24-19
Name	Kai Hansen	
Title	Managing Member, XR Communications, LLC D/B/A Vivato Technologies	

**NOTE:** Signature - This form must be signed by the applicant in accordance with 37 CFR 1.33. See 37 CFR 1.4 for signature requirements and certifications. If more than one applicant, use multiple forms.

Total of \_\_\_\_\_ forms are submitted

This collection of information is required by 37 CFR 1.131, 1.32, and 1.33. The information is required to obtain or retain a benefit by the public which is to file (and by the USPTO to process) an application. Confidentiality is governed by 35 U.S.C. 122 and 37 CFR 1.11 and 1.14. This collection is estimated to take 3 minutes to complete, including gathering, preparing, and submitting the completed application form to the USPTO. Time will vary depending upon the individual case. Any comments on the amount of time you require to complete this form and/or suggestions for reducing this burden, should be sent to the Chief Information Officer, U.S. Patent and Trademark Office, U.S. Department of Commerce, P.O. Box 1450, Alexandria, VA 22313-1450. DO NOT SEND FEES OR COMPLETED FORMS TO THIS ADDRESS. SEND TO: Commissioner for Patents, P.O. Box 1450, Alexandria, VA 22313-1450.

*If you need assistance in completing the form, call 1-800-PTO-9199 and select option 2.*

**DIRECTED WIRELESS COMMUNICATION****CROSS-REFERENCE TO RELATED APPLICATIONS**

**[0001]** This application is a continuation of U.S. Application No. 15/260,147, filed September 8, 2016, which is a continuation application of US. Patent Application No. 13/855,410, filed on April 2, 2013 (now U.S. Patent No. 9,462,589), which is a divisional application of U.S. Patent Application No. 10/700,329, filed on November 3, 2003 (now U.S. Patent No. 8,412,106), which claims the benefit of U.S. Provisional Application No. 60/423,660, filed on November 4, 2002. Each of the above-referenced patent applications is incorporated herein by reference in its entirety.

**BACKGROUND**

**[0002]** The following disclosure relates to directed wireless communication.

**[0003]** Computing devices and other similar devices implemented to send and/or receive data can be interconnected in a wired network or wireless network to allow the data to be communicated between the devices. Wired networks, such as wide area networks (WANs) and local area networks (LANs) for example, tend to have a high bandwidth and can therefore be configured to communicate digital data at high data rates. One obvious drawback to wired networks is that the range of movement of a device is constrained since the device needs to be physically connected to the network for data exchange. For example, a user of a portable computing device will need to remain near to a wired network junction to maintain a connection to the wired network.

**[0004]** An alternative to wired networks is a wireless network that is configured to support similar data communications but in a more accommodating manner. For example, the user of the portable computing device can move around within a region that is supported by the wireless network without having to be physically connected to the network. A limitation of conventional wireless networks, however, is their relatively low bandwidth which results in a much slower exchange of data than a wired network. Further, conventional wireless networks are implemented with multiple base stations, or access points, that relay communications between wireless-configured devices. These conventional access points have a limited communication range,

typically 20 to 200 feet, and a wireless network requires a large number of these access points to cover and provide a communication link over a large area.

**[0005]** Many conventional wireless communication systems and networks implement omni-directional antennas to transmit data packets to a client device and receive data packets from or via an access point. With a standard wireless LAN, for example, a transmission is communicated equally in all directions from an omni-directional antenna, or point of emanation. Receiving devices located within range and positioned at any angle with respect to the emanating point can receive the wireless transmission.

**[0006]** However, standard omni-directional wireless LANs or omni-directional wireless wide area networks (WANs) have drawbacks and limitations. For example, transmission range is limited and electromagnetic interference associated with transmissions is unmanaged and can interfere with or otherwise restrict the use of other communicating devices that operate in the same frequency band within the transmission coverage area. Furthermore, inefficiencies and data corruption can occur if two or more centralized points of emanation are positioned proximate to have overlapping coverage areas.

### **SUMMARY**

**[0007]** Directed wireless communication is described herein. In an implementation, a multi-beam directed signal system coordinates directed wireless communication with client devices. A transmit beam-forming network routes data communication transmissions to the client devices via directed communication beams that are emanated from an antenna assembly, and a receive beam-forming network receives data communication receptions from the client devices via the directed communication beams.

### **BRIEF DESCRIPTION OF THE DRAWINGS**

**[0008]** The same numbers are used throughout the drawings to reference like features and components.

**[0009]** FIG. 1 illustrates an exemplary wireless communications environment.

**[0010]** FIG. 2 illustrates an exemplary directed wireless communication system.

**[0011]** FIG. 3 illustrates an exemplary communication beam array which can be generated with the exemplary directed wireless communication system shown in FIG. 2.

**[0012]** FIG. 4 illustrates an exemplary antenna array for an antenna assembly as shown in FIG. 3.

**[0013]** FIG. 5 illustrates an exemplary implementation of the directed wireless communication system shown in FIG. 2.

**[0014]** FIG. 6 illustrates an exemplary set of communication beams that emanate from an antenna array of an antenna assembly as shown in FIG. 3.

**[0015]** FIG. 7 illustrates an exemplary multi-beam directed signal system that establishes multiple access points.

**[0016]** FIGS. 8A and 8B illustrate various components of a multi-beam directed signal system and an antenna assembly of the directed wireless communication system shown in FIG. 2.

**[0017]** FIG. 9 illustrates an exemplary multi-beam directed signal system that includes various components such as medium access controllers (MACs), baseband units, and MAC coordinator logic.

**[0018]** FIG. 10 further illustrates various components of the exemplary multi-beam directed signal system shown in FIG. 9.

**[0019]** FIG. 11 illustrates a state transition diagram for a medium access controller (MAC).

**[0020]** FIG. 12 illustrates a multi-beam directed signal system receiving and weighting various communication signals.

**[0021]** FIG. 13 illustrates an exemplary multi-beam directed signal system that includes various component implementations.

**[0022]** FIG. 14 further illustrates a component implementation of the multi-beam directed signal system for complementary beam-forming.

**[0023]** FIG. 15 illustrates a graph depicting a signal level output (dB) for the component implementation shown in FIG. 14.

**[0024]** FIG. 16 illustrates a state transition diagram for a roaming client device in wireless communication with a multi-beam directed signal system as shown in FIG. 2.

**[0025]** FIG. 17 is a flow diagram of an exemplary method for a directed wireless communication system implemented with a multi-beam directed signal system and antenna assembly.



**[0026]** FIG. 18 is a flow diagram of an exemplary method for a directed wireless communication system implemented with a multi-beam directed signal system and antenna assembly.

**[0027]** FIG. 19 is a flow diagram of an exemplary method for client device roaming in a directed wireless communication system.

### **DETAILED DESCRIPTION OF CERTAIN EMBODIMENTS**

**[0028]** Directed wireless communication is described in which a multi-beam directed signal system is implemented to communicate over a wireless communication link via an antenna assembly with client devices implemented for wireless communication within the wireless system. The directed wireless communication system can be implemented to communicate with multiple devices, such as portable computers, computing devices, and any other type of electronic and/or communication device that can be configured for wireless communication. Further, the multiple electronic and/or computing devices can be configured to communicate with one another within the wireless communication system. Additionally, a directed wireless communication system can be implemented as a wireless local area network (WLAN), a wireless wide area network (WAN), a wireless metropolitan area network (MAN), or as any number of other similar wireless network configurations.

**[0029]** The following description identifies various systems and methods that may be included in such directed wireless communication systems and networks. It should be noted, however, that these are merely exemplary and that not all of the techniques described herein need be implemented in a given wireless system or network. Furthermore, many of the exemplary systems and methods described herein are also applicable and/or adaptable for use in other communication systems and networks.

**[0030]** Directed wireless communication provides improved performance over conventional wireless network arrangements by utilizing multi-beam receiving and/or transmitting adaptive antennas, when practical. In an implementation, simultaneous transmission and reception may occur at a wireless routing device by applying multi-channel techniques. In a described implementation, a multi-beam directed signal system (e.g., also referred to as an access point or Wi-Fi switch) is a long-range packet switch designed to support 802.11b clients in accordance with an 802.11 standard. An increase in communication range is achieved by beam-forming

directed communication beams which simultaneously transmit directed signals and receive communication signals from different directions via receive and transmit beam-forming networks.

**[0031]** The multi-beam directed signal system establishes multiple point-to-point links (e.g., directed communication beams) by which data packets can be communicated. The point-to-point links have a communication range that covers a much larger area than conventional access points, eliminating the need for multiple communication access points and significantly reducing the complexity and cost of a wireless LAN (WLAN) network. Further, a client device can use a conventional wireless card to communicate with the multi-beam directed signal system over long distances with no modification of the client device. Accordingly, directed wireless communication as described herein represents a significant improvement over conventional wireless networks that use switched beam and/or omni-directional antennas.

**[0032]** FIG. 1 illustrates an exemplary wireless communications environment 100 that is generally representative of any number of different types of wireless communications environments, including but not limited to those pertaining to wireless local area networks (LANs) or wide area networks (WANs) (e.g., Wi-Fi compatible) technology, cellular technology, trunking technology, and the like. In wireless communications environment 100, an access station 102 communicates with remote client devices 104(1), 104(2), . . . , 104(N) via wireless communication or communication links 106(1), 106(2), . . . , 106(N), respectively. Although not required, access station 102 is typically fixed, and remote client devices 104 may be fixed or mobile. Although only three remote client devices 104 are shown, access station 102 can wirelessly communicate with any number of different client devices 104.

**[0033]** A directed wireless communication system, Wi-Fi communication system, access station 102, and/or remote client devices 104 may operate in accordance with any IEEE 802.11 or similar standard. With respect to a cellular system, for example, access station 102 and/or remote client devices 104 may operate in accordance with any analog or digital standard, including but not limited to those using time division/demand multiple access (TDMA), code division multiple access (CDMA), spread spectrum, some combination thereof, or any other such technology.

**[0034]** Access station 102 can be implemented as a nexus point, a trunking radio, a base station, a Wi-Fi switch, an access point, some combination and/or derivative thereof, and so forth. Remote client devices 104 may be, for example, a hand-held device, a desktop or laptop computer, an expansion card or similar that is coupled to a desktop or laptop computer, a personal digital

assistant (FDA), a mobile phone, a vehicle having a wireless communication device, a tablet or hand/palm-sized computer, a portable inventory-related scanning device, any device capable of processing generally, some combination thereof, and the like. Further, a client device 104 may be any device implemented to receive and/or transmit information (e.g., in the form of data packets) via the applicable wireless communication links 106. Remote client devices 104 may also operate in accordance with any standardized and/or specialized technology that is compatible with the operation of access station 102.

**[0035]** FIG. 2 illustrates an exemplary directed wireless communication system 200 that can be implemented in any form of a wireless communications environment 100 as described with reference to FIG. 1. The directed wireless communication system 200 includes an access station 102 and remote client devices 202 and 204. The access station 102 includes a multi-beam directed signal system 206 coupled to an antenna assembly 208 via a communication link 210. In this example implementation, access station 102 is coupled to an Ethernet backbone 212.

**[0036]** The antenna assembly 208 can be implemented as two or more antennas, and optionally as a phased array of antenna elements, to emanate multiple directed communication beams 214(1), 214(2), . . . , 214(N). The antenna assembly 208 is an unobtrusive indoor or outdoor Wi-Fi antenna panel that can include various operability components such as RF devices and components, a central processing unit, a power supply, and other logic components. The antenna assembly can be implemented as a lightweight and thin structure that can be mounted on a wall or in a corner of a room to provide wireless communication over a broad coverage area, such as throughout a building and surrounding area, or over an expanded region, such as a college campus or an entire corporate or manufacturing complex. While the antenna assembly may be applicable or adaptable for use in many other communication systems, the antenna assembly is described in the context of an exemplary wireless communications environment 100 (FIG. 1).

**[0037]** The multi-beam directed signal system 206 can transmit and/or receive (i.e., transceive) information (e.g., in the form of data packets) by way of one or more directed communication beams 214 as a wireless communication via the antenna assembly 208. Additionally, wireless communication(s) are transmitted and/or received from (i.e., transceived with respect to) a remote client device, such as client devices 202 and 204. The wireless communications may be transceived directionally with respect to one or more particular communication beams 214. The multi-beam directed signal system 206 can be implemented for

multi-channel directed wireless communication. For example, client device 202 can communicate via directed communication beam 214(1) with a first channel of the multi-beam directed signal system 206, and client device 204 can communicate via directed communication beam, 214(N) with a second channel of the multi-beam directed signal system 206.

**[0038]** In the exemplary directed wireless communication system 200, signals may be sent from a transmitter to a receiver using electromagnetic waves that emanate from one or more antenna elements of the antenna assembly 208 which are focused in one or more desired directions. For example, the multi-beam directed signal system generates a directed wireless communication for transmission to wireless client device 202 via directed communication beam 214(1). This is in contrast to conventional omni-directional transmission systems that transmit a communication in all directions from an omni-directional antenna (e.g., example omni-directional transmission area 216 emanating from a central transmission point with reference to antenna assembly 208 and shown only for comparison). Although not to scale, the illustration depicts that the power to transmit over the omni-directional transmission area 216 can be directed as one or more communication beams over a farther distance 218 from a point of transmission (e.g., antenna assembly 208).

**[0039]** When the electromagnetic waves are focused in a desired direction, the pattern formed by the electromagnetic wave is termed a “beam” or “beam pattern”, such as a directed communication beam 214. The production and/or application of such electromagnetic beams 214 is typically referred to as “beam-forming.” Beam-forming provides a number of benefits such as greater range and/or coverage per unit of transmitted power, improved resistance to interference, increased immunity to the deleterious effects of multi-path transmission signals, and so forth. For example, a single communication beam 214(1) can be directed for communication with a specific wireless-configured client device 202 and can be transmitted over a much greater distance 218 than would be covered by a conventional omni-directional antenna (e.g., example omni-directional transmission area 216 shown only for comparison).

**[0040]** FIG. 3 illustrates an exemplary communication beam array 300 of directed communication beams 214(1), 214(2), ... 214(N) that emanate from an antenna array 302 which is part of the antenna assembly 208. Antenna assembly 208 is also referred to herein as an “adaptive antenna” which describes an arrangement that includes the antenna array 302 having a plurality of antenna elements, and operatively supporting mechanisms and/or components (e.g., circuits, logic,

etc.) that are part of a wireless routing device and configured to produce a transmission pattern that selectively places transmission nulls and/or peaks in certain directions within an applicable coverage area.

**[0041]** A transmission peak of a directed communication beam 214 occurs in the transmission pattern 300 when a generated and particular amount of energy is directed in a particular direction. Transmission peaks are, therefore, associated with the signal path and/or communication beam to a desired receiving node, such as another wireless routing device or a wireless client device. In some cases, sidelobes to a communication beam may also be considered to represent transmission peak(s).

**[0042]** Conversely, a transmission null (e.g., not a communication beam) occurs in the transmission pattern when no transmission of energy occurs in a particular direction, or a relatively insignificant amount of energy is transmitted in a particular direction. Thus, a transmission null is associated with a signal path or lack of a communication beam towards an undesired, possibly interfering, device and/or object. Transmission nulls may also be associated with the intent to maximize power in another direction (i.e., associated with a transmission peak), to increase data integrity or data security, and/or to save power, for example. A determination to direct a transmission null and/or a transmission peak (e.g., a communication beam 214) in a particular direction can be made based on collected or otherwise provided routing information which may include a variety of data associated with the operation of the multi-beam directed signal system 206, wireless routing device, and other devices at other locations or nodes within the wireless network.

**[0043]** One or more of the communication beams 214(1), 214(2), . . . , 214(N) are directed out symmetrically from antenna array 302 to communicate information (e.g., in the form of data packets) with one or more wireless client devices. The communication beam array 300 shown in FIG. 3 is merely exemplary and other communication beam arrays, or patterns, may differ in width, shape, number, angular coverage, azimuth, and so forth. Further, although all of the directed communication beams 214 are shown emanating from antenna array 302 at what would appear as a same time, transmission and reception via one or more communication beams 214 is controlled and coordinated with signal control and coordination logic 304 of the multi-beam directed signal system 206.

**[0044]** The signal control and coordination logic 304 can monitor each of the directed communication beams 214 as an individual access point. Further, the signal control and coordination logic 304 can control a directed wireless transmission to a first client device and a directed wireless transmission from a second client device such that the directed wireless transmission does not interfere with the directed wireless reception. Optionally, a directed wireless transmission and a directed wireless reception can be simultaneous.

**[0045]** As used herein, the term “logic” (e.g., signal control and coordination logic 304) refers to hardware, firmware, software, or any combination thereof that may be implemented to perform the logical operations associated with a given task. Such, logic can also include any supporting circuitry that may be required to complete a given task including supportive non-logical operations. For example, “logic” may also include analog circuitry, memory, input/output (I/O) circuitry, interface circuitry, power providing/regulating circuitry, etc.

**[0046]** The directed communication beams 214 of antenna array 302 can be directionally controllable, such as steerable in an analog implementation or stepable in a digital implementation. For example, a directed communication beam 214 can be directionally stepable by the width (e.g., degrees) of the communication beam to “steer” or “aim” addressable data packets when communicating with a client device. Further, a communication beam 214 can be directionally controllable such that only an intended client device will receive a directed wireless communication via the communication beam 214, and such that an unintended recipient will not be able to receive the directed wireless communication.

**[0047]** Although data signals (e.g., information as data packets) can be directed to and from a particular client device (e.g., client devices 202 and 204) via one or more directed communication beams 214, interference between communications beams 214 can occur. For example, a downlink signal transmission from antenna assembly 208 via communication beam 214(2) can corrupt an uplink signal reception at antenna assembly 208 via communication beam 214(3). The signal control and coordination logic 304 coordinates uplink and downlink signal transmissions across (e.g., between and/or among) the different communication beams 214 so as to avoid, or at least reduce, the frequency at which downlink directed signals are transmitted via a first communication beam (e.g., communication beam 214(2)) while uplink directed signals are being received via a second communication beam (e.g., communication beam 214(3)).

**[0048]** FIG. 4 illustrates an exemplary antenna array 302 (also referred to herein as an adaptive antenna) that is formed with an array of antenna elements 400. Each antenna element 400 has multiple communication signal transfer slots 402 (e.g., transfer slots 402(1) and 402(2)) that are formed into a front surface 404 of an antenna element 400. The antenna array 302 transmits and receives data as electromagnetic communication signals via the transfer slots 402 in each antenna element 400.

**[0049]** In an exemplary implementation, the communication signal transfer slots 402 in an antenna element 400 are formed into two parallel slot rows 406(1) and 406(2) in which the transfer slots 402(1) in slot row 406(1) are staggered, or otherwise offset, in relation to the transfer slots 402(2) in slot row 406(2). Each transfer slot 402(1) in slot row 406(1) is offset from each transfer slot 402(2) in slot row 406(2) in a direction 408 and a distance 410. For example, transfer slot 402(1) in slot row 406(1) is offset from transfer slot 402(2) in slot row 408(2) in a direction that is parallel to the slot rows 406 (e.g., the direction 408) over a distance that is approximately the length of one rectangular transfer slot 402 (e.g., the distance 410). The distance 410 between transfer slots 402 in a slot row 406 is approximately the antenna element wavelength  $\lambda_g/2$  apart.

**[0050]** The gain of an adaptive antenna (e.g., antenna array 302) is dependent on the implementation of the multi-beam directed signal system 206. However, for a uniformly illuminated antenna array, the antenna gain is related to its effective aperture by an equation:

$$G_R = \frac{4\pi \cdot A_{\text{eff}}}{\lambda^2}$$

Assuming  $A_{\text{eff}}$  is equal to a cross-sectional area of the antenna array:

$$G_R = \frac{4\pi \cdot w \cdot h}{\lambda^2}$$

where  $w$  is the width of the antenna,  $h$  is the height of the antenna, and  $\lambda$  is the wavelength. For an example indoor implementation of an antenna array where  $w=8\lambda$  and  $h=4\lambda$ , the antenna gain is determined by the equation:

$$G_R = \frac{4\pi \cdot 8\lambda \cdot 4\lambda}{\lambda^2} = 128\pi = 26 \text{ dBi}$$

For an example outdoor implementation of an antenna array where  $w=8\lambda$  and  $h=8\lambda$ , the antenna gain is determined by the equation:

$$G_R = \frac{4\pi \cdot 8\lambda \cdot 8\lambda}{\lambda^2} = 256\pi = 29.1 \text{ dBi}$$

When dissipation losses are zero, the antenna gain is equivalent to directivity. The effective aperture may include the effect of losses, and therefore the formulas may be used to calculate the gain. When the actual dimensions of the antenna array 302 are used as the “effective area”, the losses are assumed to be zero (e.g., for an ideal implementation).

**[0051]** In this example illustration, the antenna array 302 is shown configured for indoor use with sixteen antenna elements (e.g., sixteen of antenna elements 400 formed or otherwise positioned together) each having two parallel rows of four communication signal transfer slots each (e.g., slot rows 406(1) and 406(2)). The antenna array 302 can be configured for outdoor use with thirty-two antenna elements (e.g., multiple antenna elements 400) each having two parallel rows of eight communication signal transfer slots each, or can be configured as a larger antenna array or antenna panel with more antenna elements having more communication signal transfer slots per slot row. The antenna array 302 can be configured with as many antenna elements 400 having any number of transfer slots 402 per slot row 406 as needed to provide communication signal transfer (e.g., wireless communication) over a region or desired coverage area.

**[0052]** FIG. 5 illustrates an exemplary implementation 500 of a directed wireless communication system (e.g., directed wireless communication system 200 shown in FIG. 2) that includes antenna assembly 208 and antenna array 302 as shown in FIG. 4. In this example, antenna array 302 is positioned outside of a building 502 and mounted on an adjacent building 504 to provide wireless communication throughout building 502 and throughout a region 506 outside of building 502. The antenna array 302 is coupled to the multi-beam directed signal system 206 (FIG. 2) which can be communicatively coupled via a LAN connection, for example, to a server computing device positioned in building 504. The server computing device can be implemented to administrate and control the associated functions and operations of the directed wireless communication system 200. Alternatively, antenna array 302 can be mounted within building 502 to provide wireless communication throughout building 502 and throughout the region 506 outside of building 502. For example, antenna array 302 can be mounted in a corner between two interior perpendicular walls to provide wireless communication coverage throughout the coverage area (e.g., building 502 and region 506 outside of the building).



**[0053]** The directed wireless communication system 200 (e.g., shown in implementation 500) provides wireless communication of information (e.g., in the form of data packets) via directed communication beams 508(1), 508(2), . . . , 508(N) to any number of electronic and/or computing client devices that are configured to recognize and receive transmission signals from the antenna array 302. Any one or more of the electronic and computing client devices may also transmit information via the directed communication beams 508. Such electronic and computing devices can include printing devices, desktop and portable computing devices such as a personal digital assistant (PDA), cellular phone, and similar mobile communication devices, and any other type of electronic devices configured for wireless communication connectivity throughout building 502, as well as portable devices outside of building 502, such as computing device 510 within region 506. One or more of the electronic and computing client devices may also be connected together via a wired network and/or communication link.

**[0054]** FIG. 6 illustrates an exemplary set or array of communication beams 600 that emanate from an antenna array 302 as shown in FIGS. 3 and 4. In a described implementation, antenna array 302 can include sixteen antenna elements 400(0, 1, . . . , 14, and 15) (not explicitly shown in FIGS. 4 and 6). From the sixteen antenna elements 400(0-15), sixteen different communication beams 602(0), 602(1), . . . , 602(15) are formed as the wireless communication signals emanating from antenna elements 400(0-15) which may add and/or subtract from each other during electromagnetic propagation.

**[0055]** Communication beams 602(1), 602(15) spread out, or are directed out, symmetrically from a central communication beam 602(0). The narrowest beam is the central beam 602(0), and the beams become wider as they spread outward from the central beam. For example, beam 602(15) adjacent beam 602(0) is slightly wider than beam 602(0), and beam 602(5) is wider than beam 602(15). Also, beam 602(10) is wider still than beam 602(5). The communication beam pattern of the set of communication beams 600 illustrated in FIG. 6 are exemplary only and other communication beam pattern sets may differ in width, shape, number, angular coverage, azimuth, and so forth.

**[0056]** Due to implementation effects of the interactions between and among the wireless signals as they emanate from antenna array 302 (e.g., assuming a linear antenna array in a described implementation), communication beam 602(8) is degenerate such that its beam pattern is formed on both sides of antenna array 302. These implementation effects also account for the

increasing widths of the other beams 602(1-7) and 602(15-9) as they spread outward from the central communication beam 602(0). In addition to the implementation effects of the interactions between and among the wireless signals, an obliquity effect explains that an azimuth beamwidth is related to the projected horizontal dimension of the array, as viewed from an oblique angle. Accordingly, the array appears narrower when viewed from an oblique angle, and therefore has a wider beamwidth as compared to a beamwidth viewed from a perpendicular angle. Beamwidth and directivity are inversely proportional and an obliquity factor (i.e.,  $\cos(\text{azimuth angle})$ ) defines a reduction in antenna array directivity at oblique angles and thus an increase in beamwidth. In a further implementation, communication beams 602(7) and 602(9) may be too wide for efficient and productive use. Hence, communication beams 602(7), 602(8), and 602(9) are not used and the implementation utilizes the remaining thirteen communication beams 602 (e.g., communication beams 602(0-6) and beams 602(10-15)).

**[0057]** FIG. 7 illustrates an exemplary implementation 700 of the multi-beam directed signal system 206 which establishes multiple access points 702(1), 702(2), 702(N). The multi-beam directed signal system 206 establishes any number access points 702 which can each correspond to, for example, an individual access point in accordance with an IEEE 802.11-based standard. Additionally, a wireless coverage area or region for each respective access point 702 may correspond to, for example, a respective directed communication beam 214 as shown in FIGS. 2 and 3, or a respective communication beam 602 as shown in FIG. 6.

**[0058]** Although communication signals directed into (or obtained from) different access points 702 may be directed at particular or specific coverage areas, interference between access points 702 can occur. For example, a downlink signal transmission for access point 702(2) can destroy an uplink signal reception for access point 702(1). Generally, signal control and coordination logic 304 coordinates uplink signal receptions and downlink signal transmissions across (e.g., between and/or among) different access points 702 so as to avoid, or at least reduce, the frequency at which downlink signals are transmitted at a first access point while uplink signals are being received at a second access point.

**[0059]** Specifically, signal control and coordination logic 304 is adapted to monitor the multiple access points 702(1), 702(2), . . . , 702(N) to ascertain when a signal, or communication of information, is being received. When an access point 702 is ascertained to be receiving a signal, the signal control and coordination logic 304 limits (e.g., prevents, delays, etc.) the transmission

of signals on the other access points 702 such that signal transmission does not interfere with signal reception. The monitoring, ascertaining, and restraining of signals can be based on and/or responsive to many factors. For example, the signals can be coordinated (e.g., analyzed and controlled) based on a per-channel basis.

**[0060]** FIGS. 8A and 8B illustrate various components of the multi-beam directed signal system 206 and the antenna assembly 208 both shown in FIGS. 2 and 3. FIG. 8A illustrates antenna array 302 which includes the sixteen antenna elements 400(0, 1, . . . , 15) as described with reference to FIG. 6. The antenna assembly 208 includes RF (radio frequency) components which are shown as a left transmit antenna board 800, a right transmit antenna board 802, a left receive antenna board 804, and a right receive antenna board 806. The multi-beam directed signal system 206 includes a transmit beam-forming network 808 and a receive beam-forming network 810.

**[0061]** The left transmit antenna board 800 includes transmission logic 812(0, 1, 7) and the right transmit antenna board 802 includes transmission logic 812(8, 9, . . . , 15). Each transmission logic 812 (e.g., circuit, component, etc.) corresponds to an antenna element 400(0-15) of the antenna array 302 and corresponds to a signal connection (e.g., node, port, channel, etc.) of the transmit beam-forming network 808(0-15). Similarly, the left receive antenna board 804 includes reception logic 814(0, 1, . . . , 7) and the right receive antenna board 806 includes reception logic 814(8, 9, 15). Each reception logic 814 (e.g., circuit, component, etc.) corresponds to an antenna element 400(0-15) of the antenna array 302 and corresponds to a signal connection (e.g., node, port, channel, etc.) of the receive beam-forming network 810(0-15).

**[0062]** Generally, a beam-forming network 808 and 810 may include multiple ports for connecting to antenna array 302 and multiple ports for connecting to the multiple RF components, such as the transmit and receive antenna boards 800-806. One or more active components (e.g., a power amplifier (PA), a low-noise amplifier (LNA), etc.) may also be coupled to the multiple ports on the antenna array side of a beam-forming network. Thus, antenna array 302 may be directly or indirectly coupled to a beam-forming network 808 and 810.

**[0063]** Specifically, a beam-forming network 808 and 810 may include at least “N” ports for each of the multiple RF transmission and receive logic components 812 and 814, respectively. For example, each directed communication beam 214 (FIG. 2) or 602 (FIG. 6) emanating from antenna array 302 corresponds to an RF logic component 812 and/or 814. Each RF logic component 812 and 814 can be implemented as, for example, a transmit and/or receive signal

processor operating at one or more radio frequencies, with each frequency corresponding to a different channel. It should be noted that channels may be defined alternatively (and/or additionally) using a mechanism other than frequency, such as a code, a time slot, some combination thereof, and so forth.

**[0064]** FIG. 8B further illustrates various components of the multi-beam directed signal system 206 which includes the signal control and coordination logic 304, a multi-beam controller 816, one or more memory components 818, communication interface(s) 820, a scanning receiver 822, and receiver/transmitters (Rx/Tx) 824(0, 1, . . . , 15). The multi-beam controller 816 (e.g., any of a processor, controller, logic, circuitry, etc.) can be implemented to control channel assignments for communication signals and data communication coordinated by the signal control and coordination logic 304.

**[0065]** The channel assignments coordinated by the signal control and coordination logic 304 provides the best channel assignment for a signal based on given measurement information. Parameters of a channel assignment algorithm include:

**[0066]** *ChannelAssignmentCycle* which identifies a duration between changes in the channel assignment;

**[0067]** *HeavyInterference* which identifies an interference activity threshold. If, for example, interference activity is determined to be above this value, a particular channel may be considered deficient for the duration of time that the interference can be detected;

**[0068]** *BadChannelThreshold* which identifies a number of measurement periods (e.g., a *MeasurementDuration*) that a channel has interference activity above the *HeavyInterference* threshold; and

**[0069]** *JamInterference* which identifies an interference activity threshold above the *HeavyInterference* parameter.

**[0070]** Further, channel assignment internal parameters can include:

**[0071]** *MeasurementCycle* which identifies a time duration (e.g., twenty-four hours) in which a measurement is completed;

**[0072]** *MeasurementDuration* which identifies a time duration (e.g., minutes) between two measurement points;

**[0073]** *PeakLoadLimit* which identifies a maximum load allowed on one channel; and

**[0074]** *ChannelSixBiasFactor* which is a bias factor to compensate for transmission on channel six to reduce inter-modulation.

**[0075]** The scanning receiver 822 and the receiver/transmitters (Rx/Tx) 824 measure metrics of channel activity every specified *MeasurementDuration* during a cycle of *MeasurementCycle*. The metrics can include a number of associated client devices, throughput and packet error rates (PER) of each receiver/transmitter 824, interference and channel utilization of each communication beam (e.g., frequency, or channel), and/or any number of other metrics. The channel activity metrics include:

**[0076]**  $N_i(t)$  which is a number of associated clients of the  $i$ th Rx/Tx 824 and which is averaged over the *MeasurementDuration* period;

**[0077]**  $S_i(t)$  which is the throughput of the  $i$ th Rx/Tx 824 measured in packets/second or bytes/second, and which is averaged over the *MeasurementDuration* period;

**[0078]**  $P_i(t)$  which is a packet error rate (PER) of the  $i$ th Rx/Tx 824 and which is averaged over the *MeasurementDuration* period;

**[0079]**  $D_i(t)$  which is a delay of the  $i$ th Rx/Tx 824 and which is averaged over the *MeasurementDuration* period;

**[0080]**  $\rho_{ij}(t)$  which is channel utilization of the  $i$ th beam on the  $j$ th channel and which is measured by both the Rx/Tx 824 and scanning receiver 822 and averaged over the *MeasurementDuration* period. This is also referred to as a Channel Utilization Factor (CUF);

**[0081]**  $N_{s_j}(t)$  which is a number of downlink data packets transmitted on the  $j$ th channel and which is averaged over the *MeasurementDuration* period;

**[0082]**  $N_{r_{ij}}(t)$  which is a number of correctly received uplink data packets transmitted by client devices associated with the  $i$ th beam on the  $j$ th channel, and which is averaged over the *MeasurementDuration* period;

**[0083]**  $N_{n_{ij}}(t)$  which is a number of uplink data packets transmitted by client devices associated with other communication beams, and which are correctly received by the  $i$ th beam on the  $j$ th channel. This is measured by the scanning receiver 822 and is averaged over the *MeasurementDuration* period. This is also referred to as the Self Interference Metric (SIM);

**[0084]**  $N_{o_{ij}}(t)$  which is a number of uplink data packets transmitted by the client devices from overlapping subnets and which are correctly received by the  $i$ th beam on the  $j$ th channel. This

is measured by the scanning receiver 822 and is averaged over the *MeasurementDuration* period. This is also referred to as the Overlapping Subnet Interference (OSI);

**[0085]**  $Ne_{ij}(t)$  which is a number of uplink data packets with PLCP or data CRC errors in the  $i$ th beam on the  $j$ th channel and which is measured by the scanning receiver 822 and averaged over the *MeasurementDuration* period. This is also referred to as the Unidentified Interference Metric (UIM); and

**[0086]**  $I_{ij}(t)$  which is the interference of the  $i$ th beam on the  $j$ th channel and which is measured by the scanning receiver 822.

**[0087]** These and other metrics can be maintained with a memory component 818 in a data table (or similar data construct) within the *MeasurementCycle*. When the cycle restarts, the data table can either be cleared or updated with some aging factor to identify past metrics.

**[0088]** The metric  $I_{ij}(t)$  can be derived from other measurements when the receiver/transmitters 824 are on the same channel. In such cases,  $I_{ij}(t)$  can be estimated by first estimating a total number of packets from any overlapping subnets by an equation:

$$NI_{ij}(t) = No_{ij}(t) + Ne_{ij}(t) \cdot \frac{No_{ij}(t)}{Nr_{ij}(t) + Nn_{ij}(t) + No_{ij}(t)}$$

Further,  $I_{ij}(t)$  may be estimated by:

$$I_{ij}(t) = \frac{NI_{ij}(t)}{NS_i(t) + Nr_{ij}(t) + Nn_{ij}(t) + No_{ij}(t) + Ne_{ij}(t)} \cdot P_{ij}(t)$$

**[0089]** For channel assignment pre-processing, a channel that has interference activity which exceeds *HeavyInterference* for a *BadChannelThreshold* is not used. The interference activity is averaged over intervals of the *MeasurementDuration* period. In an implementation, a *MeasurementCycle* can include forty-eight measurement intervals. A channel can be eliminated if the interference activity *HeavyInterference* exceeds the *BadChannelThreshold* for a specified number of periods.

**[0090]** The total number of active users (e.g., client devices) associated with any one directed communication beam 214 (FIG. 2) or 602 (FIG. 6) can be estimated by dividing the number of associated users of that communication beam by the percentage of time available to those users. The total number of users on beam  $i$  and channel  $j$  may therefore be described by:

$$N_{ij}(t) = \frac{N_i(t)}{1 - \sim I_{ij}(t)}$$

where  $\mathcal{I}_{ij}(t) = \min\{I_{ij}(t), \text{HeavyInterference}\}$  which is the interference activity limited to a maximum allowable interference on a given communication beam. This ensures that the estimate does not provide large peaks due to an unusual period of high interference.

**[0091]** A block-based channel assignment algorithm assigns adjacent communication beams to the same frequency channel which minimizes the hidden beam problem as described further with reference to FIG. 14. The algorithm allocates the thirteen communication beams into a maximum of three blocks, with each block assigned to one frequency channel (e.g., channels 1, 6, or 11) so that the peak load on each channel is minimized. To determine an optimal solution, the boundaries between the assignment blocks (i.e. the number of communication beams in each block) and the frequency channel of each block is determined.

**[0092]** There are sixty-six possible combinations that divide thirteen communication beams into three blocks. For each of these possible combinations, the three blocks would be assigned to the three different channels. The number of channel permutations is six and the best channel-beam combination from three hundred, ninety-six ( $66 \times 6 = 396$ ) possible combinations can be determined. A factor  $L_j(t)$  is denoted as the total load on the  $j$ th frequency channel at time ( $t$ ) such that  $L_j^* = \max\{L_j(t)\}$  where  $t$  is of the set  $[0, T]$  which is the peak load on the  $j$ th channel in the last measurement period, and where  $T$  is the measurement cycle (i.e., *MeasurementCycle*). A combination can be determined that minimizes the peak load on all of the channels which can be described as  $\min\{\max\{L_j^*\}\}$  where  $j$  is of the set  $[f_1 f_6 f_{11}]$ .

**[0093]** In an event that the overall network communication load, or traffic, is minimal, fewer than the three frequency channels may be used. A parameter *PeakLoadLimit* identifies a communication load limit below which only two of the frequency channels (e.g., channel 1 and channel 11, for example) are used. If the peak communication load on either of the two channels exceeds the *PeakLoadLimit*, then the three frequency channels can be utilized.

**[0094]** The block-based channel assignment algorithm can be implemented to utilize two or three frequency channels. Initially, the thirteen communication beams are divided into two blocks of which there are twelve possible combinations. For each combination, the channel selections can be  $f_1 f_6$ ,  $f_1 f_{11}$ ,  $f_6 f_1$ ,  $f_6 f_{11}$ ,  $f_{11} f_1$ , or  $f_{11} f_6$  such that there are a total of seventy-two block and channel combinations. Assuming that the  $k$ th block-channel combination has a configuration as follows:

**[0095]** Block 1: communication beams 0 to  $b_k$  (0 to  $N-2$ ) are assigned to channel  $C_1$ ; and

**[0096]** Block 2: communication beams  $b_k + 1$  to  $N-1$  (1 to  $N-1$ ) are assigned to channel  $C_2$ . Then the communication traffic load of channels  $C_1$  and  $C_2$  are:

$$L_{C_1}^k(t) = \sum_{i=0}^{b_k} N_{iC_1}(t)$$

$$L_{C_2}^k(t) = \sum_{i=b_k+1}^{N-1} N_{iC_2}(t)$$

**[0097]** The peak communication load on the first block for combination  $k$  is denoted by:

$$PL_1(k) = \max \{L_{C_1}^k(t)\} \text{ where } t \text{ is of the set } [0, T]$$

$$PL_2(k) = \max \{L_{C_2}^k(t)\} \text{ where } t \text{ is of the set } [0, T],$$

**[0098]** And the peak communication load for the busiest block (e.g., channel) is:

$$PL_{max}(k) = \max \{PL_1(k), PL_2(k)\}$$

**[0099]** A combination index  $R$  with the least peak communication load is then selected such that  $PL_{max}(R) = \min \{PL_{max}(k)\}$  where  $(0 \leq k \leq 71)$  which is the combination of channels and beams that minimize the peak load on any channel. If the peak load on a channel is not less than the *PeakLoadLimit*, then a three channel assignment can be implemented. Initially, the thirteen communication beams are divide into three blocks of which there are sixty-six possible combinations. For each combination, the channel selections can be  $f_1f_6f_{11}$ ,  $f_1f_{11}f_6$ ,  $f_6f_1f_{11}$ ,  $f_6f_{11}f_1$ ,  $f_{11}f_1f_6$ , or  $f_{11}f_6f_1$  such that there are a total of three-hundred, ninety-six block and channel combinations. Assuming that the  $k$ th block-channel combination has a configuration as follows:

**[0100]** Block 1: communication beams 0 to  $b_k$  (0 to  $N-3$ ) are assigned to channel  $C_1$ ; and

**[0101]** Block 2: communication beams  $b_k + 1$  to  $p_k$  (1 to  $N-2$ ) are assigned to channel  $C_2$ ; and

**[0102]** Block 3: communication beams  $p_k + 1$  to  $N-1$  (2 to  $N-1$ ) are assigned to channel  $C_3$ ;

**[0103]** Then the communication traffic load of channels  $C_1$ ,  $C_2$ , and  $C_3$  are:



$$L_{C1}^{ki}(t) = \sum_{i=0}^{b_k} N_{iC1}(t)$$

$$L_{C2}^k(t) = \sum_{i=b_k+1}^{p_k} N_{iC2}(t)$$

$$L_{C3}^k = \sum_{i=p_k+1}^{N-1} N_{iC3}(t)$$

**[0104]** The peak communication load on the first block for combination  $k$  is denoted by:

$$PL_1(k) = \max\{L_{C1}^k(t) \text{ where } t \text{ is of the set } [0, T]\}$$

$$PL_2(k) = \max\{L_{C2}^k(t) \text{ where } t \text{ is of the set } [0, T]\},$$

$$PL_3(k) = \max\{L_{C3}^k(t) \text{ where } t \text{ is of the set } [0, T]\},$$

**[0105]** and the peak communication load for the busiest block (e.g., channel) is:

$$PL_{max}(k) = \max\{PL_1(k), PL_2(k), PL_3(k)\}$$

**[0106]** A combination index  $R$  with the least peak communication load is then selected such that  $PL_{max}(R) = \min\{PL_{max}(k)\}$  where  $(0 \leq k \leq 395)$  which is the combination of channels and beams that minimize the peak load on any channel.

**[0107]** When taking into account intermodulation such that channel combinations  $f_1f_6$  and  $f_6f_{11}$  are to be avoided, then  $f_6$  is avoided. Initially, the thirteen communication beams are divide into two blocks of which there are twelve possible combinations. For each combination, the channel selections can be  $f_1f_{11}$  and  $f_{11}f_1$  such that there are a total of twenty-four block and channel combinations. Assuming that the  $k$ th block-channel combination has a configuration as follows:

**[0108]** Block 1: communication beams 0 to  $b_k$  (0 to  $N-2$ ) are assigned to channel  $C_1$ ; and

**[0109]** Block 2: communication beams  $b_k+1$  to  $N-1$  (1 to  $N-1$ ) are assigned to channel  $C_2$

Then the communication traffic load of channels  $f_1$  and  $f_{11}$  is the sum of the loads of the communication beams assigned to those channels as follows:

$$L_{f_1}^k(t) = \sum_{f_1} N_{if_1}(t) \quad \forall (i \in f_1)$$

$$L_{f_{11}}^k(t) = \sum_{f_{11}} N_{if_{11}}(t) \quad \forall (i \in f_{11})$$

**[0110]** The peak communication load on the first block for combination  $k$  is denoted by:

$$PL_1(k) = \max \{L_{f_1}^k(t)\} \text{ where } t \text{ is of the set } [0, T]$$

$$PL_2(k) = \max \{L_{f_{11}}^k(t)\} \text{ where } t \text{ is of the set } [0, T],$$

**[0111]** and the peak communication load for the busiest block (e.g., channel) is:

$$PL_{max}(k) = \max \{PL_1(k), PL_2(k)\}$$

**[0112]** A combination index  $R$  with the least peak communication load is then selected such that  $PL_{max}(R) = \min \{PL_{max}(k)\}$  where  $(0 \leq k \leq 71)$  which is the combination of channels and beams that minimize the peak load on any channel. If the peak load on a channel is not less than the *PeakLoadLimit*, then a three channel assignment can be implemented.

**[0113]** Memory component(s) 818 can maintain routing and signal information which can include transmit power level information, transmit data rate information, antenna pointing direction information, weighting information, constraints information, null/zero location information, peak location information, quality of service (QoS) information, priority information, lifetime information, frequency information, timing information, user and node authentication information, keep out area information, etc., that is associated with each sending and receiving communication channel of the wireless communication system and within the multi-beam directed signal system 206. In an implementation, at least some of routing information can be maintained with memory component(s) 818 within one or more routing tables or similar data structure(s).

**[0114]** The routing table(s) or similar data structure(s) provide an information basis for each routing decision within the wireless communication system (e.g., multi-beam directed signal system 206). By way of example, routing table(s) entries may include all or part of the following information: IP address (e.g., IPv6) of a node in the wireless network—e.g., as an index; 48-bit unique address—e.g., IEEE 802.1 MAC address; Protocol ID—e.g., IEEE 802.11, 802.16.1, etc.; Modulation method; Connection ID (CID) of a node—e.g., as used in an IEEE 802.16.1 MAC; Nominal direction to a node—e.g., one or two dimension; Nominal transmit power level to a node; Nominal received signal strength indicator (RSSI) level from a node; Nominal channel to transmit

on, and perhaps a backup channel; Nominal channel to receive on, and perhaps a backup channel; Nominal transmission data rate, e.g., 6 Mbps-54 Mbps, or as available; Nominal receive data rate, e.g., 6 Mbps-54 Mbps, or as available; Known station interference nulls; and Unknown station interference nulls.

**[0115]** In an exemplary implementation, and within the structure of signal control/coordination logic 304, the routing table(s) are configured to receive or include data and/or primitives (e.g., function calls) from an Internet Protocol (IP) layer and a medium access control (MAC) layer, and to instruct a physical (PHY) layer to provide media access through the MAC layer. Therefore, in some examples, a routing table is more than simply a data table (or other similar structure) since it may also perform or otherwise support controlling and/or scheduling functions.

**[0116]** The communication interface(s) 820 can be implemented as any one of a serial, parallel, network, or wireless interface that communicatively couples the multi-beam directed signal system 206 with other electronic and/or computing devices. For example, the multi-beam directed signal system 206 can be coupled with a wired connection (e.g., an input/output cable) via a communication interface 820 to a network switch that communicates digital information corresponding to a communication signal to a server computing device. Any of the communication interfaces 820 can also be implemented as an input/output connector to couple digital, universal serial bus (USB), local area network (LAN), wide area network (WAN), metropolitan area network (MAN), and similar types of information and communication connections.

**[0117]** The scanning receiver 822 scans each directed communication beam (e.g., directed communication beams 214 shown in FIGS. 2 and 3) consecutively and monitors for client devices and associated information such as the transmit power of a client device, roaming status, and the many other communication factors to update data that is maintained about each client device that is in communication via a communication beam. In an implementation, the scanning receiver 822 can be described in two operating states: a scan mode and a roaming mode. While operating in the scan mode, the scanning receiver 822 periodically scans the thirteen communication beams on the three channels and collects activity information to be maintained with the client device data.

**[0118]** FIG. 9 illustrates an exemplary multi-beam directed signal system 206 that includes various components such as medium access controllers (MACs) 900, baseband units (BB) 902, and MAC coordinator logic 904. The multi-beam directed signal system 206 also includes radio

frequency (RF) components 906 such as the left and right transmit antenna boards 800 and 802 (shown in FIG. 8), respectively, and the left and right receive antenna boards 804 and 806, respectively. This example also illustrates the antenna array 302, the transmit beam-forming network 808 and the receive beam-forming network 810, and an Ethernet switch and/or router 908.

**[0119]** As described in the implementation with reference to FIG. 8, antenna array 302 (e.g., via antenna assembly 208) is coupled to the beam-forming networks 808 (transmit) and 810 (receive). The beam-forming networks 808 and 810 are coupled to multiple RF components 906(1), 906(2), . . . , 906(N). Respective RF components 906(1), 906(2), . . . , 906(N) are each coupled to a respective baseband unit 902(1), 902(2), . . . , 902(N) which are coupled to MAC coordinator logic 904. The Ethernet switch/router 908 is coupled to the multiple MACs 900(1), 900(2), . . . , 900(N) which are also each coupled to MAC coordinator logic 904.

**[0120]** In operation generally, each MAC 900 is associated with a respective baseband unit 902. Although not specifically shown in FIG. 9, each respective MAC 900 may also be communicatively coupled to a corresponding baseband unit 902. MAC coordinator logic 904 is configured to coordinate the activities of the multiple MACs 900 with regard to at least one non-associated respective baseband unit 902. For example, MAC coordinator logic 904 may forward an instruction to MAC 900(1) responsive, at least partly, to an indicator provided from baseband unit 902(2). MAC coordinator logic 904 can be implemented as hardware, software, firmware, and/or some combination thereof.

**[0121]** The Ethernet switch/router 908 is coupled to Ethernet backbone 212 (FIG. 2) and is configured to relay incoming packets from Ethernet backbone 212 to the appropriate MAC 900 to which they correspond. Ethernet switch/router 908 is also configured to relay outgoing packets from the multiple MACs 900 to Ethernet backbone 212. Ethernet switch/router 908 may be implemented using, for example, a general purpose central processing unit (CPU) and memory. The CPU and memory can handle layer-2 Internet protocol (IP) responsibilities, flow control, and so forth. When receiving packets from Ethernet backbone 212, Ethernet switch/router 908 obtains the destination port for the destination MAC 900 address. In this manner, an Ethernet switch and/or router may be realized using software (or hardware, firmware, some combination thereof, etc.).

**[0122]** The beam-forming networks 808 and 810, in conjunction with antenna array 302, form the multiple directed communication beams 214 (FIGS. 2 and 3). A beam-forming network can be implemented as an active or passive beam-former. Examples of such active and passive

beam-formers include a tuned vector modulator (multiplier), a Butler matrix, a Rotman lens, a canonical beam-former, a lumped-element beam-former with static or variable inductors and capacitors, and so forth. Alternatively, communication beams may be formed using full adaptive beam-forming.

**[0123]** As described with reference to FIGS. 8A and 8B, a beam-forming network 808 and 810 may include multiple ports for connecting to antenna array 302 and additional ports for connecting to the multiple RF components 906. One or more active components (e.g., a power amplifier (PA), a low-noise amplifier (LNA), etc.) may also be coupled to the multiple ports on the antenna array side of the beam-forming networks 808 and 810. Thus, antenna array 302 may be directly or indirectly coupled to the beam-forming networks 808 and 810.

**[0124]** The beam-forming networks 808 and 810 may include at least “N” parts for each of the multiple RF components 906(1, 2, . . . , N). In an example implementation, each communication beam 214 emanating from antenna array 302 corresponds to an RF component 906. Each RF component 906 can be implemented as a transmit and/or receive signal processor operating at radio frequencies and each RF component 906 can operate at one or more frequencies, with each frequency corresponding to a different channel. It should be noted that channels may be defined alternatively (and/or additionally) using a mechanism other than frequency, such as a code, a time slot, a signal node, some combination thereof, and so forth.

**[0125]** As described above, each respective RF component 906(1, 2, . . . , N) is coupled to a respective baseband unit 902(1, 2, N) and each respective MAC 900(1, 2, . . . , N) is associated with a corresponding baseband unit 902(1, 2, . . . , N). Although not illustrated in this example or required, each MAC 900 and associated respective baseband unit 902 may be located on individual respective electronic cards. Additionally, the respective RF component 906 to which each respective baseband unit 902 is coupled may also be located on the individual respective electronic cards.

**[0126]** Each respective MAC 900 and corresponding baseband unit 902 may be associated with a different respective access point, such as access points 702(1, 2, . . . , N) (FIG. 7). Each respective RF component 906, along with signal nodes (e.g., ports, communication nodes, etc.) of the beam-forming networks 808 and 810, and/or antenna array 302, and respective communication beams 214 may also correspond to the different respective access points 702. The MACs 900 are configured to control access to the media that is provided, at least partially, by baseband units 902.

In this case, the media corresponds to the signals transmitted and/or received via communication beams 214 (FIGS. 2 and 3). These signals can be analog, digital, and so forth. In a described implementation, digital signals comprise one or more data packets.

**[0127]** In a packet-based environment, a data packet arriving at the multi-beam directed signal system 206 (or at access station 102) via a particular communication beam 214 from a particular remote client device 202 (FIG. 2) is received via the antenna array 302 and the beam-forming networks 808 and/or 810. The data packet is processed through a particular RF component 906 and a corresponding baseband unit 902. The data packet is then forwarded from baseband unit 902 to a corresponding MAC 900 which facilitates data packet communication via the Ethernet backbone 212 (FIG. 2) by Ethernet switch/router 908. Data packets arriving at the multi-beam directed signal system 206 (or at access station 102) via Ethernet switch/router 908 are transmitted to a remote client device 202 and/or 204 via directed communication beam(s) 214 in an opposite communication path. The transmission and reception of data packets via directed communication beams 214, as well as the forwarding of packets within the multi-beam directed signal system 206 is controlled at least partially by the MACs 900.

**[0128]** In a typical MAC-baseband environment, a MAC controls the associated baseband circuitry using input solely from the associated baseband circuitry. For example, if baseband circuitry indicates to its associated MAC that it is receiving a packet, then the associated MAC does not initiate the baseband circuitry to transmit a packet, which can jeopardize the integrity of the packet being received.

**[0129]** With co-located access points 702 (e.g., as in FIG. 7) and/or co-located pairs of MACs 900 and associated baseband units 902, a first access point 702(1) and/or a first MAC 900(1)/baseband unit 902(1) pair are unaware of the condition or state (e.g., transmitting, receiving, idle, etc.) of a second access point 702(2) and/or a second MAC 900(2)/baseband unit 902(2) pair, and vice versa. As a result, absent additional control and/or logic, a data packet being received by the first access point 702(1) and/or the first MAC 900(1)/baseband unit 902(1) pair can be corrupted (e.g., altered, destroyed, interfered with, rendered unusable for its intended purpose, etc.) by a transmission from the second access point 702(2) and/or the second MAC 900(2)/baseband unit 902(2) pair. This corruption may occur even though the packet reception and the packet transmission are effectuated using different communication beams 214(3) and 214(2), respectively, when the reception and transmission occur on the same channel. Effectively, an

incoming data packet reception via a first communication beam 214 can be rendered unsuccessful by an outgoing data packet transmission via a second communication beam 214 that occurs on the same channel and is overlapping.

**[0130]** As described above, MAC coordinator logic 904 is coupled to the multiple baseband units 902(1, 2, . . . , N) and to the multiple MACs 900(1, 2, . . . , N). The MAC coordinator logic 904 is configured to prevent MACs 900(1, 2, . . . , N) from generating or otherwise causing a transmission if at least one and optionally if any of the baseband units 902(1, 2, . . . , N) are receiving. For example, if baseband unit 902(2) indicates that it is receiving a data packet, MAC coordinator logic 904 initiates that MACs 900(1, 2, . . . , N) refrain from generating or otherwise causing a data packet transmission during the data packet reception. Factors that can modify, tune, tweak, extend, etc. this data packet transmission restraint may include one or more of the MACs 900 enabling transmissions on different channel(s) from that of baseband unit 902(2) which is receiving.

**[0131]** More specifically, each baseband unit 902 forwards a corresponding receive indicator to MAC coordinator logic 904 which monitors the baseband units 902. The MAC coordinator logic 904 analyzes the receive indicators to generate constructive receive indicators that are communicated, or otherwise provided, to each of the MACs 900. In a described implementation, each baseband unit 902 forwards a receive indicator that reflects whether and/or when a baseband unit 902 is currently receiving a signal. Optionally, not physically forwarding an indicator may constitute a receive indicator that reflects no signal is being received. After processing the different receive indicators, MAC coordinator logic 904 forwards the same constructive receive indicator to each MAC 900 based on multiple, and possibly all, receive indicators. The MAC coordinator logic 904 may provide different constructive receive indicators to at least different subsets of the MACs 900.

**[0132]** The receive indicators forwarded to MAC coordinator logic 904 may be comprised of any one or more different indications from the baseband units 902. For example, the receive indicators may comprise clear channel assessment (CCA) or busy/non-busy indications. Alternatively, the receive indicators may comprise indications of signal reception based on energy signals, cross-correlation signals, data signals, other transmit and/or control signals, seine combination thereof, and so forth. Furthermore, a receive indicator may comprise an analog or

digital indication (of one or more bits), the driving of one or more lines, the presentation of one or more messages, some combination thereof, and so forth.

**[0133]** The MAC coordinator logic 904 is configured to accept the receive indicators from the baseband units 902 and combine them in some manner to generate or otherwise produce the constructive receive indicator(s). For example, MAC coordinator logic 904 may “OR” the receive indicators together to generate the constructive receive indicator(s). Consequently, if any receive indicator from baseband units 902 indicates that a baseband unit is receiving a signal, then, the constructive receive indicator indicates to each MAC 900 that a reception is occurring on a directed communication beam 214 (and/or access point 702) of the multi-beam directed signal system 206. As a result, the MACs 900 that are provided with an affirmative constructive receive indicator do not cause their respective associated baseband units 902 to transmit.

**[0134]** The constructive receive indicators provided from MAC coordinator logic 904 may be comprised of any one or more different indications interpretable by the MACs 900. For example, the constructive receive indicators may comprise an indication for one or more predetermined inputs, such as a CCA or busy/non-busy input of the MACs 900. Alternatively, the constructive receive indicators may be input to a different type of do-not-transmit input, a specially-designed input, a message-capable input, some combination thereof, and so forth. Furthermore, a constructive receive indicator may comprise an analog or digital indication (of one or more bits), the driving of one or more lines, the presentation of one or more messages, some combination thereof, and the like.

**[0135]** FIG. 10 further illustrates various components of the multi-beam directed signal system 206 shown in FIG. 9 which includes the MACs 900, baseband units 902, and MAC coordinator logic 904. In this example, the exemplary multi-beam directed signal system 206 includes thirteen MACs 900(1, 2, . . . , 13) and thirteen baseband units 902(1, 2, . . . , 13) that are associated respectively therewith. Thirteen baseband units 902(1, 2, . . . , 13) and thirteen MACs 900(1, 2, . . . , 13) are utilized in this exemplary multi-beam directed signal system 206 to comport with the efficiently usable communication beams 602(0-6) and 602(10-15) of the exemplary set of communication beams shown in FIG. 6. However, the elements and features described with reference to FIG. 10 are applicable to multi-beam directed signal systems 206 and/or access stations 102 with more than or fewer than thirteen MACs 900 and associated baseband units 902.



**[0136]** The baseband units 902(1, 2, . . . , 13) are configured to communicate with MACs 900(1, 2, . . . , 13), and vice versa, directly or indirectly without MAC coordinator logic 904 input. Specifically, control data may be transferred there between which may include, for example, data packets for wireless communication on communication beams 214 (FIGS. 2 and 3), carrier sense multiple access/collision avoidance (CSMA/CA) type information, and so forth. The media access technique in 802.11 is based on a Carrier Sense Multiple Access (CSMA) operation in which a each station transmits only when it determines that no other station is currently transmitting. This tends to avoid collisions that occur when two or more stations transmit at the same time where a collision would typically require that a transmitted packet be retransmitted.

**[0137]** In this example, the baseband units 902(1, 2, . . . , 13) forward receive indicators (1, 2, . . . , 13) to MAC coordinator logic 904. The MAC coordinator logic 904 includes a receive indicators combiner 1000 which may be comprised of one or more of program coding, a field-programmable gate array, discrete logic gates, and so forth, and which may be implemented as hardware, software, firmware, and/or some combination thereof. Receive indicators combiner 1000 combines receive indicators (1, 2, . . . , 13) to generate constructive receive indicators (1, 2, . . . , 13). For example, receive indicators (1, 2, . . . , 13) may be combined using a logical “OR” functionality which ensures that if any one or more receive indicators of receive indicators (1, 2, . . . , 13) is indicating that a signal is being received, then the associated constructive receive indicators of constructive receive indicators (1, 2, . . . , 13) also indicate that a signal is being received.

**[0138]** The constructive receive indicators (1, 2, . . . , 13) are provided or otherwise communicated to MACs 900(1, 2, . . . , 13), respectively, so that MACs 900(1, 2, . . . , 13) do not cause baseband units 902(1, 2, . . . , 13) to transmit a signal while another signal is being received. The baseband units 902(1, 2, . . . , 13) and the MACs 900(1, 2, . . . , 13) may be segmented or grouped by a characteristic and/or state, such as by wireless communication channels. When segmented or grouped, a constructive receive indicator of a given segment or group indicates to a MAC that a signal is being received and that no signal should therefore be transmitted when any receive indicator of that given segment or group indicates that a signal is being received (or when multiple receive indicators of that given segment or group indicate that multiple signals are being received).

**[0139]** The MAC coordinator logic 904 can be modified, adjusted, expanded, etc. based on any number of different factors that include channel assignment information 1002, receive indicator enable information 1004, timer logic 1006, and scanning logic 1008. Although illustrated as separate components, any one or combination of the channel assignment information 1002, receive indicator enable information 1004, timer logic 1006, and/or scanning logic 1008 can be implemented together and/or as part of MAC coordinator logic 904 or as another component of a multi-beam directed signal system 206.

**[0140]** Channel assignment information 1002 enables receive indicators (1, 2, . . . , 13) to be combined by the receive indicators combiner 1000 on a per-channel basis. As a result, constructive receive indicators (1, 2, . . . , 13) restrain signal transmissions from MAC 900 and baseband unit 902 pairs when a signal reception is occurring on the same channel, even if by a different MAC 900 and baseband unit 902 pair. A downlinked data packet that is transmitted on one channel while an uplinked data packet is being received on another channel does not usually cause the uplinked data packet to be corrupted. On the other hand, a downlinked data packet that is transmitted on a channel while an uplinked data packet is being received on the same channel does usually cause the uplinked data packet to be corrupted (e.g., indistinguishable, non-communicative, etc.), even if the transmission and reception occur via different communication beams 214 (FIGS. 2 and 3).

**[0141]** Channel assignment information 1002 may be implemented as, for example, a vector that relates each MAC 900 and associated baseband unit 902 to one of two or more channels. Hence, prior to a combination generated by the receive indicators combiner 1000, each respective receive indicator (1, 2, . . . , 13) can be mapped to a channel segmentation or grouping based on a wireless communication channel used by a corresponding MAC 900 and baseband unit 902 pair.

**[0142]** Receive indicator enable information 1004 provides information for receive indicators combiner 1000 that stipulates which receive indicators (1, 2, . . . , 13) are to be used in a combination operation to produce the constructive receive indicators (1, 2, . . . , 13). Thus, certain receive indicators may be excluded from the combination operation for one or more operational considerations. The receive indicator enable information 1004 may be implemented as, for example, a masking register 1010 that comprises a register with exclusionary bits for masking one or more of the receive indicators (1, 2, . . . , 13) from a combination operation of the receive indicators combiner 1000. In a described implementation, masking register 1010 includes thirteen

bits that correspond to the thirteen receive indicators (1, 2, . . . , 13), which correspond to the thirteen baseband units 902(1, 2, . . . , 13).

**[0143]** Timer logic 1006 can be used for one or more factors and, although only shown once, may alternatively be implemented as multiple components in an exemplary multi-beam directed signal system 206 to account for multiple timer functions, or one implementation may be capable of handling multiple timer functions. Timer logic 1006 includes a watchdog timer 1012 and optionally watchdog interrupt enable information 1014.

**[0144]** For a first factor, timer logic 1006 relates to individual receive indicators (1, 2, . . . , 13). A duration of watchdog timer 1012 is set equal to a maximum data packet duration (e.g., a maximum-allowed length of a data packet). Watchdog timer 1012 is started when a particular receive indicator begins indicating that a signal is being received and stopped when the particular receive indicator ceases indicating that the signal is being received. If watchdog timer 1012 is not tolled by an indication of signal reception cessation prior to its expiration, then the signal being received is likely to not be intended for multi-beam directed signal system 206. In this case, timer logic 1006 may indicate that the baseband unit 902 corresponding to the particular receive indicator is not to be used in a combination operation. This exclusion indication may be effectuated using receive indicator enable information 1004 (e.g., by setting a bit in masking register 1010).

**[0145]** For a second factor, timer logic 1006 relates to constructive receive indicators (1, 2, . . . , 13) on a per-channel basis. A duration of watchdog timer 1012 is set with consideration of a temporal threshold beyond which a problem or error should be contemplated to have occurred and hence investigated. Watchdog timer 1012 is started when a particular constructive receive indicator (or indicators) for a given channel begins indicating that a signal is being received on the given channel and stopped when the particular constructive receive indicator ceases indicating that the signal is being received on the given channel. If watchdog timer 1012 is not tolled by an indication of signal reception cessation prior to its expiration, then there is a likelihood that an error has occurred.

**[0146]** Watchdog interrupt enable information 1014 is used for this second factor, and it stipulates which channel(s) (and thus which constructive receive indicators) are enabled for interruption. If watchdog timer 1012 expires and the given channel is enabled in accordance with watchdog interrupt enable information 1014, an interrupt is generated and provided to MAC coordinator logic 904 or another component of the multi-beam directed signal system 206.

**[0147]** Scanning logic 1008 may act independently or interactively with any one or more of channel assignment information 1002, receive indicator enable information 1004, and timer logic 1006. For example, scanning logic 1008 can scan across communication beams 214 using different channels on receive to detect which channel or channels have the least or lowest interference levels. This scanning may occur once, periodically, continuously, and the like. A channel assignment vector or similar for channel assignment information 1002 may be configured responsive to such scanning and interference determinations of scanning logic 1008.

**[0148]** As another example, scanning logic 1008 may scan across communication beams 214 to detect the presence of other access points (e.g., non-co-located access points) that are causing interference on a regular or constant basis. The existence of an access point may be inferred by receiving a basic service set identifier (BSSID) being broadcast by another access point. When another access point is detected within a coverage area of a particular communication beam 214 (e.g., when an overlapping subnet is detected), scanning logic 1008 may interact with receive indicator enable information 1004 to mask out a corresponding receive indicator from a baseband unit 902 that corresponds to the particular communication beam 214. As a result, frequent receptions from the overlapping subnet do not constantly prevent baseband unit 902 and MAC 900 pairs on the same channel from transmitting.

**[0149]** In an exemplary implementation, multi-beam directed signal system 206 can be configured such that the receive indicators (1, 2, . . . , 13) correspond to the state of the clear channel assessment (CCA) output as detected by baseband units 902(1, 2, . . . , 13), and the constructive receive indicators (1, 2, . . . , 13) correspond to the state of the clear channel assessment input to MACs 900(1, 2, . . . , 13). Based on the values for receive indicators (1, 2, . . . , 13), channel assignment information 1002, and receive indicator enable information 1004, MAC coordinator logic 904 determines the constructive receive indicators (1, 2, . . . , 13) for each RF component 906 (FIG. 9) (as provided via MACs 900, baseband units 902, etc.).

**[0150]** In an exemplary implementation, MAC coordinator logic 904 is configured to operate such that an indicator “channel\_wide\_busy” for each channel is defined, where channel\_wide\_busy is affirmative (e.g., active) if the receive indicator from any baseband units operating on that channel indicates that a signal is being received, excluding those baseband units whose receive indicator enable information is not set (e.g., in masking register 1010). Further, MAC coordinator logic 904 sets the constructive receive indicator for a particular MAC 900 and

baseband unit 902 pair to affirmative (e.g., busy) if the receive indicator for that baseband unit 902 indicates affirmative (e.g., busy), or if “channel\_wide\_busy” for the channel of the particular MAC 900 and baseband unit 902 pair is affirmative (e.g., active).

**[0151]** FIG. 11 illustrates a state transition diagram 1100 for a MAC controller 900 as shown in FIGS. 9 and 10. MAC controller states include Defer 1102, BackOff 1104, Idle 1106, TransmissionRTS (TxRTS) 1108, WaitCTS 1110, Transmission Data (TxData) 1112, Wait Acknowledgement (WaitACK) 114, Receive 1116, Transmission Acknowledgement (TxACK) 1118, and TransmissionCTS (TxCTS) 1120. The state transition diagram 1100 also includes received frame types Data 1126 and RTS 1128, as well as procedures Transmission okay (TxOK( )) 1122 and Transmission fail (TxFail( )) 1124.

**[0152]** The TxOK( ) procedure 1122 removes bytes transmitted from an outgoing queue and resets retry counter(s) and a contention window. The TxFail( ) procedure 1124 increments a retry counter, checks that the number of retries has not been exceeded, and increases the contention window. The Receive state 1116 ends if there is a transmission or check error, if the carrier is lost, or when a duration indicated in a header has elapsed. If there is an error, the Defer state 1102 timeout is set to initiate. If a frame did not have an error and is not addressed to a particular station, and its duration field is greater than the current timer value, then the timer is set to the value of the frame's duration field.

**[0153]** At the BackOff state 1104, a backoff counter is decremented every slot time and a backoff count is saved if this state is exited due to a channel becoming busy. When the backoff counter decrements to zero and MAC service data units are queued to transmit, the contention window and retry counts are reset. A MAC service data unit is the payload carried by a MAC (e.g., in an 802.11 implementation which will typically be an Ethernet frame). The MAC 900 adds a MAC header and a 32-bit CRC to the MAC service data unit to form a MAC protocol data unit.

**[0154]** Additionally, the state transition diagram 1100 includes various functions that return logical value(s) to control state transitions such as data( ), short( ), more( ), busy( ), error( ), notforus( ), and nav( ). The diagram 1100 also includes PHY indications that initiate a state transition such as busy, timeout, new, transmission end (txend), and receive end (rxend). The PHY indications are asynchronous events (e.g., interrupts) that terminate states for a MAC controller 900. An indication receive end (rxend) identifies that a receiver has detected the end of a frame or an error. An indication transmission end (txend) identifies that a receiver has completed sending a

frame. A busy indication is a receiver indication that a channel is busy. A timeout indication is generated when a transition state timer has expired. A new indication identifies that a new frame has been queued.

**[0155]** A busy( ) function returns a receiver indication that a channel is busy, and an error( ) function indicates that a received frame had a CRC error. A notforus( ) function indicates that a frame was not addressed to a particular station, and a nay( ) function indicates that a timer has not expired. A data( ) function indicates that data is queued to send, and a short( ) function indicates that a MAC protocol data unit is shorter than an RTS Threshold and that there are additional data fragments to be sent from a current MAC controller. A more( ) function facilitates obtaining the additional data fragments.

**[0156]** FIG. 12 illustrates an exemplary implementation 1200 of the multi-beam directed signal system 206 that weighs signals received via antenna array 302. Communication and/or data transfer signals are received from sources 1202 (e.g., sources A and B). The signals received from sources 1202 are considered desired signals because they are from nodes within the wireless routing network. Further, signals such as noise and WLAN interference associated with another external wireless system 1204 are not desired.

**[0157]** These signals, both desired and undesired, are received via antenna array 302 and are provided to the signal control and coordination logic 304 (shown in FIG. 3) from the receiver/transmitters (Rx/Tx) 824(0), 824(1), . . . , 824(N) (also shown in FIG. 8B). In this example, the signal control and coordination logic 304 includes the scanning receiver 822 that is configured to update routing information 1206 with regard to the received signals. For example, scanning receiver 822 may identify information about different classes of interferers (e.g., known and unknown types) within the routing information 1206. In this example, routing information 1206 includes connection indexed routing table(s) based on identification information, such as address information, CID, and the like. The routing table includes identifiers of the desired sources and other identifiers for the interferers (“Int”). Further, the routing table includes stored weighting values (w) each associated with a particular signal source 1202 (e.g., sources A and B). Other information such as “keep out” identifiers may also be included in this exemplary routing table.

**[0158]** A description of the received signal(s) can be stored in the routing table in the form of the pattern or weighting of the signal(s). In this example, a polynomial expansion in z,  $w(z)=w_0+w_1z+w_2z^2+w_3z^3+w_4z^4+\dots+w_iz^i$  can be utilized to establish the values of the weights

$w_i$ ) to be applied to a weight vector. The routing table(s) may store such weighing patterns as a function of  $\theta$ , or the zeroes of the polynomial, for example. One advantage of zero storage is that the zeros represent directions for communication that should be nulled out to prevent self-interference or interfering with other nodes or possibly other known wireless communication systems, such as WLAN 1204 that is not part of the wireless routing network, but is operating within at least a portion of a potential coverage area 1208 and frequency bands.

**[0159]** The polynomial expansion in  $z$ ,  $w(z)$ , and the zeroes may be calculated from each other and each may be stored. Updates can be generated frequently (e.g., in certain implementations, about every millisecond), and a zero storage system may be more advantageous in most wireless network environments because only a few values will change at a given time. Storing the weighting values will in general require changes to all of the weighting values  $w(i)$  when any change in the pattern occurs. Note that  $w(i)$  and  $A(\theta)$  may be expressed as Fourier transform pairs (discrete due to the finite antenna element space). The  $w(i)$  is equivalent to a time domain impulse response (e.g., a time domain unit sample response) and the  $A(\theta)$  is equivalent to the frequency response (e.g., an evaluation of  $w(z)$  sampled along a unit circle).

**[0160]** The stored weighting values associated with each connection, data signal, and/or source are utilized in a weighting matrix 1210 which operates to apply the latest weighting values to the received signals and also to transmitted signals. In this illustrative example, subsequently received signals will be processed using the most recent weighting values in the weighting matrix 1210. Thus, as described herein, the multi-beam directed signal system 206 is configured to control the transmission amplitude frequency band and directionality of data packets to other nodes and assist in reducing the effects associated with received noise and interference (e.g., self interference and/or external interference). This is accomplished with the signal control and coordination logic 304 within the multi-beam directed signal system 206.

**[0161]** FIG. 13 illustrates an exemplary multi-beam directed signal system 206 that includes an antenna array 302 and a Butler matrix 1300 implemented as a beam-forming network (e.g., transmit beam-forming network 808 and/or receive beam-forming network 810 shown in FIGS. 8A and 8B). The multi-beam directed signal system 206 also includes multiple signal processors (SPs) 1302 and one or more baseband processors (e.g., baseband units 902 described with reference to FIGS. 9 and 10). Baseband processors 902 accept communication signals from and provide communication signals to the multiple receiver/transmitters 824 (FIG. 8B). A separate

baseband processor 902 may be assigned to each signal processor 1302, or a single baseband processor 902 may be assigned to any number of the multiple signal processors 1302.

**[0162]** Exemplary Butler matrix 1300 is a passive device that forms, in conjunction with antenna array 302, communication beams 214 using signal combiners, signal splitters, and/or signal phase shifters. Butler matrix 1300 includes a first side with multiple antenna ports (designated by “A”) and a second side with multiple transmit and/or receive signal processor ports (designated by “Tx/Rx”). The number of antenna ports and transmit/receive ports indicate the order of the Butler matrix 1300, which in this example, includes sixteen antenna ports and sixteen transmit/receive ports. Thus, Butler matrix 1300 has an order of sixteen.

**[0163]** Although Butler matrix 1300 is so illustrated, the antenna ports and transmit/receive ports need not be distributed on separate, much less opposite, sides of a Butler matrix. Also, although not necessary, Butler matrices typically have an equal number of antenna ports and transmit and/or receive signal processor ports. Furthermore, although Butler matrices are typically of an order that is a power of two (e.g., 2, 4, 8, 16, 32, 64, . . . ,  $2^n$ ), they may alternatively be implemented with any number of ports.

**[0164]** The sixteen antenna ports of Butler matrix 1300 are identified or otherwise numbered from A(0, 1, . . . , 15). Similarly, the sixteen transmit/receive ports are numbered from Tx/Rx(0, 1, . . . , 15). Antenna ports A(0-15) are coupled to and populated with sixteen antenna elements 400(0), 400(1), . . . , 400(15), respectively. Likewise, transmit/receive ports Tx/Rx(0-15) are coupled to and populated with sixteen signal processors 1302(0), 1302(1), . . . , 1302(15), respectively. These signal processors 1302 are also directly or indirectly coupled to baseband processors 902. It should be noted that one or more active components (e.g., a power amplifier (PA), a low-noise amplifier (LNA), etc.) may also be coupled on the antenna port side of Butler matrix 1300.

**[0165]** In an exemplary transmission operation, communication signals are provided from baseband processors 902 to the multiple transmit and/or receive signal processors 1302. The multiple signal processors 1302 forward the communication signals to the transmit/receive ports Tx/Rx(0-15) of Butler matrix 1300. After signal processing (e.g., signal combination, signal splitting, signal phase shifting, and the like), Butler matrix 1300 outputs communication signals on the antenna ports A(0-15). Individual antenna elements 400 wirelessly transmit the communication signals, as altered by Butler matrix 1300, from the antenna ports A(0-15) in



predetermined communication beam patterns. The communication beam patterns are predetermined by the shape, orientation, constituency, etc. of antenna array 302 and by the Butler matrix 1300 signal processing. In addition to transmissions, wireless signals such as wireless communications 106 (FIG. 1) are received responsive to the communication beams 214 formed by antenna array 302 in conjunction with Butler matrix 1300 in an inverse process.

**[0166]** FIG. 14 further illustrates an exemplary modified Butler matrix 1300 for a complementary beam-forming, post-combining implementation, Complementary beam-forming is a technique to reduce the effect of communication beam nulls and increase sidelobe levels without a severe power penalty to the main beam. This is done to reduce the effect of the “hidden beam.” As described below, increasing the range of 802.11 networks without increased transmit power and using standard clients is possible with adaptive antenna arrays, such as, for example, directional high-gain antennas. Using high gain antennas, it is possible to direct the energy in a given direction and hence increase the range in that direction.

**[0167]** Forming directional transmit communication beams has the side effect of hiding the transmitted energy from some client devices in a CSMA network (i.e., negatively impacting the carrier sense mechanism in the network). A client device measures the energy transmitted from access points and from other client devices. If the client device cannot detect the presence of other transmissions, it attempts to access the medium. Therefore, when directional communication beams are used, many client devices detect the medium as idle when in fact it is busy. This has an effect on the performance of the network and is referred to as the “hidden beam” problem.

**[0168]** In practice, a communication beam (e.g., directional beam) has a main beam whose width can be controlled by the size of the antenna aperture, and sidelobes which vary in different directions. However, these communication beams may have nulls in certain directions that affect the wireless network with a hidden beam. Since a given receiver's energy detect threshold is usually lower than it's decoding threshold, it is possible to direct a high power signal towards an intended client device and yet ensure a minimum transmit power towards other clients in the network so that the signal may be detected by other clients.

**[0169]** Complementary beam-forming ensures a minimum transmit power in all directions while preserving the shape of the main communication beam. The complementary beam-forming techniques also ensure that multiple transmit beams in arbitrary directions are complemented by

another beam in all other directions. The complementary beam does not interfere with the intended beams and increases the probability that other users in the network can detect the signal.

**[0170]** The modified Butler matrix 1300 includes the antenna ports 400(0, 1, . . . , N-1, N) and a gain mechanism 1400 configured to modify the signal at output port 400(0). A transmit signal is input to a corresponding input port of the Butler matrix and, in conjunction with the gain mechanism 1400, a complementary beam is formed due to the increase in gain. The result is a directional communication beam from the antenna in a given direction. A complementary beam-forming, pre-combining implementation can also be implemented.

**[0171]** Mathematically, a complementary beam-forming, post-combining implementation may be described as:

$$y_i = \begin{cases} \gamma y_i & i = 0 \\ y_i & \gamma \geq 1 \end{cases} \quad 0 \leq i \leq N-1$$

**[0172]** where  $y_i$  is the power applied to antenna element  $i$  and  $\gamma$  is the gain value contained in the gain mechanism 1400. To ensure the same output power as with no complementary beam-forming, the output voltage on all of the Butler matrix ports can be adjusted by a scaling factor:

$$G_s = \frac{N}{\sqrt{\gamma^2 + N - 1}}$$

**[0173]** The power for the main communication beam will then be:

$$\Delta P = \frac{(\gamma + N - 1)^2}{N(\gamma^2 + N - 1)}$$

**[0174]** or stated in terms of dB:

$$\Delta P_{dB} = 10 \log \left\{ \frac{(\gamma + N - 1)^2}{N(\gamma^2 + N - 1)} \right\}$$

**[0175]** For example, for a sixteen element antenna array 302, if  $\gamma=3.5$ , then the power loss is approximately 1 dB.

**[0176]** FIG. 15 illustrates a graph 1500 depicting the signal level output (dB) for certain ports of the modified Butler Matrix 1300 shown in FIG. 14. Graph 1500 depicts the shape of a

transmit communication beam 1502 without complementary beam-forming and a transmit communication beam 1504 with complementary beam-forming applied. In this example, the transmit communication beam is derived from a signal at port 400(0) of Butler Matrix 1300. As shown, the output with complementary beam-forming (e.g., transmit communication beam 1504) has higher sidelobes in all directions and removes all of the deep nulls except for the nulls on the main communication beam. The peak power of the main communication beam is approximately one dB lower than that without complementary beam-forming.

**[0177]** FIG. 16 illustrates a transition diagram 1600 for a roaming client device that transitions from one communication location within a wireless network system to another. For example, client device 202 (FIG. 2), while in wireless communication with access station 102 via directed communication beam 214(1) may roam (e.g., move, relocate, transition, etc.) such that communication with access station 102 would be facilitated via directed communication beam 214(2). A client device initially associates to one directed signal of the multi-beam directed signal system 206 by selecting the signal (e.g., communication beam) with the best signal at the time of association. However, because the client device may be portable and/or the wireless environment may change (e.g., due to device transitions, interference, etc.), the initially selected directed signal may not provide a continuous, or the best, communication channel over which to communicate information (e.g., in the data packets) and hence the client may have to roam and/or be associated with another directed communication beam.

**[0178]** Roaming is dependent on client device implementation, is initiated by a client device, and may not be directly controlled by the multi-beam directed signal system 206. In most commercially available client devices, roaming is triggered when the channel quality (SNR) falls below a threshold. The channel quality assessment (SNR measurement) is based on received strength of a directed communication beam. To ensure that a client device is associated with the best signal, the multi-beam directed signal system 206 directs the client device to roam to the directed communication beam with the best signal quality using a beam-switching algorithm.

**[0179]** Additionally, to ensure seamless roaming between communication beams, the multi-beam directed signal system 206 implements Inter-Access Point Protocol (IAPP) which is defined by IEEE 802.11f to support interoperability, mobility, handover messaging between directed communication beams 214, and coordination between access stations 102 in a wireless communications environment. Beam-switching can be implemented by the multi-beam controller

816 (FIG. 8B) in the multi-beam directed signal system 206 to ensure that client devices are associated with the directed communication beam 214 having the best signal level and IAPP to ensure client-initiated seamless roaming.

**[0180]** The beam-switching algorithm disassociates a client device once it moves out of an associated main communication beam. However, such movement of a client device is difficult to detect in the wireless environment and disassociation may result in data packet loss and a long association procedure. The effect is particularly significant for client devices located between adjacent directed communication beams. Hence, the beam-switching algorithm will disassociate a client device when there is a determinable difference between signal qualities on different communication beams.

**[0181]** With reference to FIG. 16, a client device may be described as being in a monitor state 1602, a correct beam test state 1604, and a force roam state 1606. In the monitor state 1602, a client device is associated with a directed communication beam 214 while the multi-beam directed signal system 206 (e.g., access station 102) continues to sample and collect receive strength signal indications (RSSI) values for each data packet received from the client device. The multi-beam controller 816 recalculates a new measure identified as a smoothed RSSI value (*SmoothedRSSIValue*) over an RSSI window size (*RSSIWindowSize*) and compares it to an RSSI lower control limit threshold (*RSSILowerControlLimit*).

**[0182]** In the correct beam test state 1604, the scanning receiver 822 measures the RSSIs and calculates a smoothed RSSI value (*SmoothedRSSIValue*) for the client device on each of the adjacent ports (e.g., communication beams). Samples of the RSSI window size (*RSSIWindowSize*) for the two adjacent ports are averaged and compared to the same parameter for the current communication beam to determine the best, or most effective, communication beam. In the force roam state 1606, the client device is temporarily disassociated so that it cannot associate to the current directed communication beam.

**[0183]** An association transition 1608 to the correct beam test state 1604 occurs when a client device associates a directed communication beam 214. From the correct beam test state 1604, a correct beam transition 1610 indicates that a current communication beam is the best communication link between the client device and the multi-beam directed signal system. New RSSI values are sampled and a new lower control limit (*LowerControlLimit*) is recalculated. A scan timeout transition 1612 from the correct beam test state 1604 indicates that the scanning

receiver 822 has been monitoring the adjacent communication beams for more than a roaming scan timeout duration (*RoamingScanTimeout*) without any decision about the correct beam.

**[0184]** From the monitor state 1602, a sample RSSI transition 1614 indicates that the smoothed RSSI value (*SmoothedRSSIValue*) and the RSSI lower control limit (*RSSILowerControlLimit*) are re-calculated. A smoothed RSSI drop transition 1616 from the monitor state 1602 drops the smoothed RSSI value (*SmoothedRSSIValue*) to an RSSI lower control limit (*RSSILowerControlLimit*). A wrong beam transition 1618 from the correct beam test state 1604 indicates a better communication beam is identified that has an RSSI that exceeds the RSSI of the current communication beam by a signal drop threshold dB (*SignalDropThreshold*). The client device is disassociated from the current communication beam and a timeout transition 1620 occurs after a roaming time out (*RoamingTimeOut*). The state information corresponding to the client device is then removed (e.g., deleted, discarded, etc.).

**[0185]** The lower control limit parameter (*LowerControlLimit*) is calculated using both the mean and the standard deviation of RSSI as follows:

$$\text{LowerControlLimit} = \overline{\text{RSSI}} - 2\sigma$$

$$\overline{\text{RSSI}} = \frac{1}{N} \sum_{i=0}^{N-1} \text{RSSI}_i \quad N = \text{RSSIWindow Size in frames}$$

$$\sigma = \sqrt{\frac{1}{N} \sum_{i=0}^{N-1} (\text{RSSI}_i - \overline{\text{RSSI}})^2}$$

**[0186]** The  $\text{RSSI}_i$  is the RSSI value reported for frame  $i$ . The  $N-1$ th frame is the most recent frame. The smoothed RSSI value (*SmoothedRSSIValue* ( $S$ )) is calculated when RSSI values are sample when a data packet is received. The smoothed RSSI value is calculated as  $S_j = 0.1 * \text{RSSI}_j + 0.9 * S_{j-1}$ . This value is then compared to the lower control limit (*LowerControlLimit*) and if it is larger than the limit, the client device enters the correct beam test state 1604. The IAPP seamless roaming enables seamless client-initiated roaming between communication beams within an

antenna panel, between antenna panels, and between an antenna panel and third party access points (e.g., access stations, multi-beam directed signal system, etc.).

**[0187]** Methods for directed wireless communication may be described in the general context of computer-executable instructions. Generally, computer-executable instructions include routines, programs, objects, components, data structures, and the like that perform particular functions or implement particular abstract data types. Methods for directed wireless communication may also be practiced in distributed computing environments where functions are performed by remote processing devices that are linked through a communications network. In a distributed computing environment, computer-executable instructions may be located in both local and remote computer storage media, including memory storage devices.

**[0188]** FIG. 17 illustrates a method 1700 for directed wireless communication. The order in which the method is described is not intended to be construed as a limitation, and any number of the described method blocks can be combined in any order to implement the method. Furthermore, the method can be implemented in any suitable hardware, software, firmware, or combination thereof.

**[0189]** At block 1702, a directed wireless communication is generated for data communication with a client device. At block 1704, the directed wireless communication is received at an antenna assembly, and at block 1706, a directed communication beam is emanated for the data communication with the client device. For example, the multi-beam directed signal system 206 (shown in FIG. 2) generates a directed wireless communication for data communication with client device 202. Antenna assembly 208 receives the generated wireless communication and emanates a directed communication beam 214(1) for the data communication with client device 202. In an embodiment, the directed communication beam can be emanated from two or more antenna elements of the antenna assembly as an electromagnetic signal that includes transmission peaks and transmissions nulls within a coverage area of the directed communication beam 214(1).

**[0190]** At block 1708, the data communication is transmitted to the client device via the directed communication beam. At block 1710, a second directed communication beam is emanated for data communication reception from a second client device, and at block 1712, a second data communication is received from the second client device via the second directed communication beam. For example, an additional directed communication beam 214(N) can be emanated from

antenna assembly 208 for data communication reception from client device 204. The data communication transmission (at block 1708) can be controlled so as not to interfere with receiving the second data communication (at block 1712) and optionally, transmitting the data communication and receiving the second directed data communication is simultaneous.

**[0191]** FIG. 18 illustrates a method 1800 for directed wireless communication. The order in which the method is described is not intended to be construed as a limitation, and any number of the described method blocks can be combined in any order to implement the method. Furthermore, the method can be implemented in any suitable hardware, software, firmware, or combination thereof.

**[0192]** At block 1802, directed wireless communication is coordinated with client devices via directed communication beams emanated from an antenna assembly. For example, wireless communications are coordinated by the signal control and coordination logic 304 (shown in FIG. 3) with client devices 202 and 204 (FIG. 2) via directed communication beams 214(1) and 214(N), respectively, which are emanated from antenna assembly 208. A directed communication beam can be emanated as an electromagnetic signal that includes transmission peaks and transmission nulls within a coverage area of the directed communication beam. Further, energy can be transmitted on a side lobe of a directed communication beam corresponding to a first client device such that a second client device will detect the side lobe energy and recognize that a data communication transmission is being emanated to the first client device via the directed communication beam.

**[0193]** The directed wireless communication can be coordinated such that only client device 202 receives a first directed wireless communication via communication beam 214(1), and such that only client device 204 receives a second directed wireless communication via communication beam 214(N). Coordinating directed wireless communication can include simultaneous data communication transmission to client device 202 via directed communication beam 214(1) and a data communication reception from client device 204 via directed communication beam 214(N). Further, the data communication transmission is coordinated so as not to interfere with the data communication reception.

**[0194]** At block 1804, data communication transmissions are routed through a transmit beam-forming network to antenna elements of the antenna assembly such that a data communication transmission is communicated to a client device via a directed communication

beam. At block 1806, the directed communication beams are monitored for data communication receptions from the client devices. At block 1808, data communication receptions are received through a receive beam-forming network from the antenna elements of the antenna assembly such that a data communication reception is received from a client device via a directed communication beam. For example, a data communication reception can be received from a client device with scanning receiver 822 (shown in FIG. 8B).

**[0195]** At block 1810, a determination is made as to which of multiple channels provides acceptable data communication transmission and/or reception with a client device. At block 1812, information is maintained corresponding to one or more of the client devices. The information can include a transmit power level, a data transmit rate, an antenna direction, quality of service data, and timing data. Further, coordinating a directed wireless communication with a client device (as described in block 1802) can be based on the information that is maintained (at block 1812).

**[0196]** FIG. 19 illustrates a method 1900 for directed wireless communication. The order in which the method is described is not intended to be construed as a limitation, and any number of the described method blocks can be combined in any order to implement the method. Furthermore, the method can be implemented in any suitable hardware, software, firmware, or combination thereof.

**[0197]** At block 1902, a client device is associated with a directed communication beam. For example, a portable client device 202 (shown in FIG. 2) is associated with communication beam 214(1) (shown in FIGS. 2 and 3). At block 1904, signal strength indications are received for data packets received from the client device via the directed communication beam. At block 1906, a signal strength average for the client device is calculated from the received signal strength indications.

**[0198]** At block 1908, adjacent signal strength indications are sampled for an adjacent directed communication beam. At block 1910, a second signal strength average is calculated for the adjacent directed communication beam. For example, signal strength indications are sampled for an adjacent directed communication beam 214(2) (shown in FIGS. 2 and 3), and a signal strength average is calculated for the adjacent directed communication beam 214(2).

**[0199]** At block 1912, the signal strength average is compared to the second signal strength average and a determination is made as to which provides a more effective, or better, communication link. If the second signal strength average does not indicate that the adjacent



directed communication beam would provide a better communication link than the directed communication beam (i.e., no from block 912), then the client device association with the initial directed communication beam is maintained at block 914.

**[0200]** If the second signal strength average indicates that the adjacent directed communication beam would provide a better communication link than the directed communication beam (i.e., no from block 912), then the client device is disassociated with the directed communication beam at block 916. At block 918, the client device is re-associated with the adjacent directed communication beam. The method 1900 can then continue and be reiterated from block 1902. Additionally, the method 1900 can be implemented for any number of client devices in wireless communication with a directed wireless communication system.

**[0201]** Although wireless communication system(s) have been described in language specific to structural features and/or methods, it is to be understood that the subject of the appended claims is not necessarily limited to the specific features or methods described. Rather, the specific features and methods are disclosed as exemplary implementations of wireless communication system(s).

WHAT IS CLAIMED IS:

1. A receiver for use in a wireless communications system, the receiver comprising:
  - a smart antenna comprising at least a first antenna element and a second antenna element;
  - a transceiver operatively coupled to the smart antenna and configured to transmit and receive electromagnetic signals using the smart antenna; and
  - a processor operatively coupled to the transceiver, the processor configured to:
    - receive a first signal transmission from a remote station via the first antenna element and a second signal transmission from the remote station via the second antenna element simultaneously;
    - determine first signal information for the first transmission;
    - determine second signal information for the second transmission, wherein the second signal information is different than the first signal information;
    - determine a set of weighting values based on the first signal information and the second signal information, wherein the set of weighting values is configured to construct one or more beam-formed transmission signals; and
    - cause the transceiver to generate the one or more beam-formed transmission signals based on the set of weighting values for transmission to the remote station.
2. The receiver as recited in Claim 1, wherein the processor is further configured to: cause the transceiver to transmit the one or more beam-formed transmission signals to the remote station via the smart antenna.
3. The receiver as recited in Claim 1, wherein the first signal transmission and the second signal transmission comprise electromagnetic signals comprising one or more transmission peaks and one or more transmission nulls.
4. The receiver as recited in Claim 1, wherein the first signal transmission and the second signal transmission are directional transmissions.

5. The receiver as recited in Claim 1, wherein the set of weighting values is further based on one or more of: a transmit power level, a data transmit rate, an antenna direction, quality of service data, or timing data.

6. The receiver as recited in Claim 1, wherein the one or more beam-formed transmission signals comprise data configured to be used by the remote station to modify the placement of one or more transmission peaks and one or more transmission nulls in a subsequent signal transmission.

7. The receiver as recited in Claim 1, wherein the processor is further configured to:  
determine a plurality of signal strength indications for the first signal transmission;  
determine a first signal strength average based on the plurality of signal strength indications for the first signal transmission;  
determine a plurality of signal strength indications for the second signal transmission;  
determine a second signal strength average based on the plurality of signal strength indications for the second signal transmission; and  
cause the transceiver to generate the one or more beam-formed transmission signals based on the first signal strength average and the second signal strength average.

8. The receiver as recited in Claim 8, wherein the processor is further configured to:  
cause the transceiver to transmit the one or more beam-formed transmission signals to the remote station via the smart antenna.

9. A method in a wireless communications system, the method comprising:  
receiving a first signal transmission from a remote station via a first antenna element of a smart antenna and a second signal transmission from the remote station via a second antenna element of the smart antenna simultaneously;  
determining first signal information for the first transmission;  
determining second signal information for the second transmission, wherein the second signal information is different than the first signal information;

determining a set of weighting values based on the first signal information and the second signal information, wherein the set of weighting values is configured to construct one or more beam-formed transmission signals; and

generating the one or more beam-formed transmission signals based on the set of weighting values for transmission to the remote station.

10. The method as recited in Claim 9, further comprising: transmitting the one or more beam-formed transmission signals to the remote station via the smart antenna.

11. The method as recited in Claim 9, wherein the first signal transmission and the second signal transmission comprise electromagnetic signals comprising one or more transmission peaks and one or more transmission nulls.

12. The method as recited in Claim 9, wherein the first signal transmission and the second signal transmission are directional transmissions.

13. The method as recited in Claim 9, wherein the set of weighting values is further based on one or more of: a transmit power level, a data transmit rate, an antenna direction, quality of service data, or timing data.

14. The method as recited in Claim 9, wherein the one or more beam-formed transmission signals comprise data configured to be used by the remote station to modify the placement of one or more transmission peaks and one or more transmission nulls in a subsequent signal transmission.

15. The method as recited in Claim 9, wherein the processor is further configured to:  
determining a plurality of signal strength indications for the first signal transmission;

determining a first signal strength average based on the plurality of signal strength indications for the first signal transmission;

determining a plurality of signal strength indications for the second signal transmission;

determining a second signal strength average based on the plurality of signal strength indications for the second signal transmission; and

generating the one or more beam-formed transmission signals based on the first signal strength average and the second signal strength average.

16. The method as recited in Claim 15, wherein the processor is further configured to: cause the transceiver to transmit the one or more beam-formed transmission signals to the remote station via the smart antenna.

17. An apparatus for use in a wireless communications system, the apparatus comprising:

a smart antenna comprising at least a first antenna element and a second antenna element;

a transceiver operatively coupled to the smart antenna; and

a processor operatively coupled to the transceiver, the processor configured to:

receive a first signal transmission from a remote station via the first antenna element, the first signal transmission comprising first signal information;

receive a second signal transmission from the remote station via the second antenna element, the second signal transmission comprising second signal information;

determine a set of weighting values based on the first signal information and the second signal information, wherein the set of weighting values is configured to construct one or more beam-formed transmission signals;

cause the transceiver to transmit the one or more beam-formed transmission signals based on the set of weighting values to the remote station.

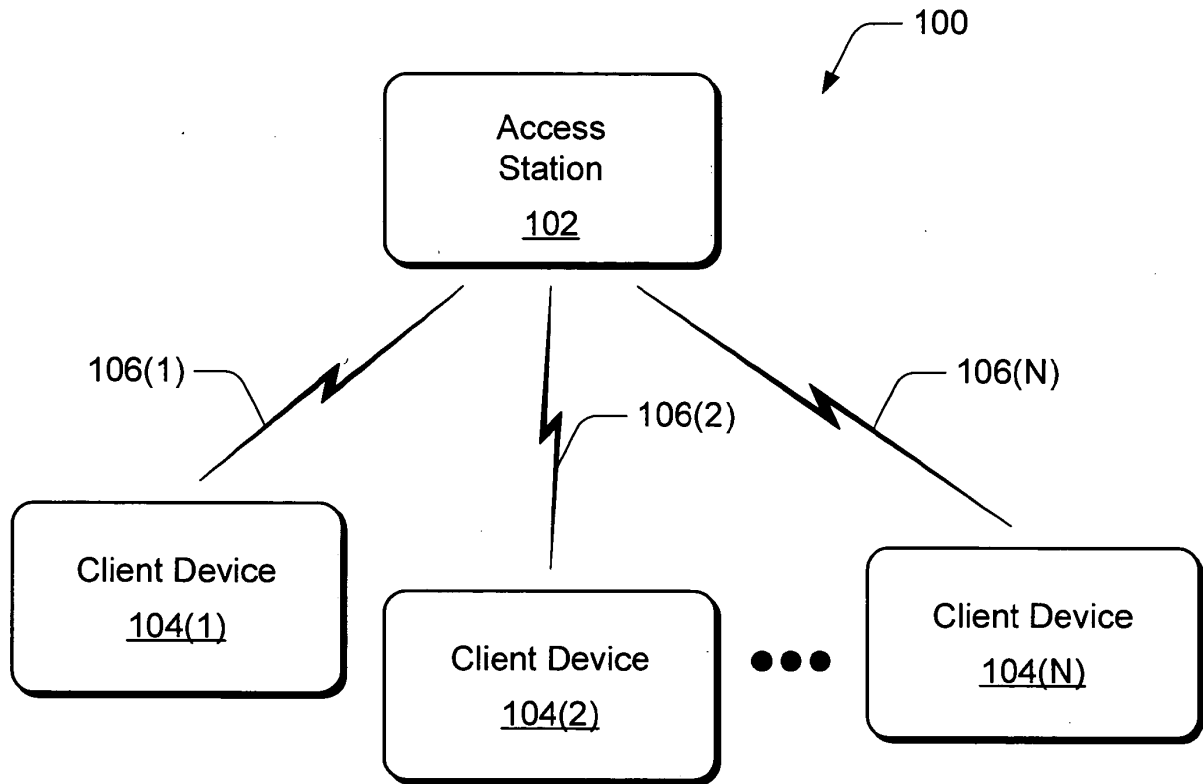
18. The apparatus as recited in Claim 17, wherein the first signal transmission and the second signal transmission comprise electromagnetic signals comprising one or more transmission peaks and one or more transmission nulls.

19. The apparatus as recited in Claim 17, wherein the first signal information comprises one or more of: a transmit power level, a data transmit rate, an antenna direction, quality of service data, or timing data.

20. The apparatus as recited in Claim 17, wherein the first antenna element and the second antenna element are directional antenna elements.

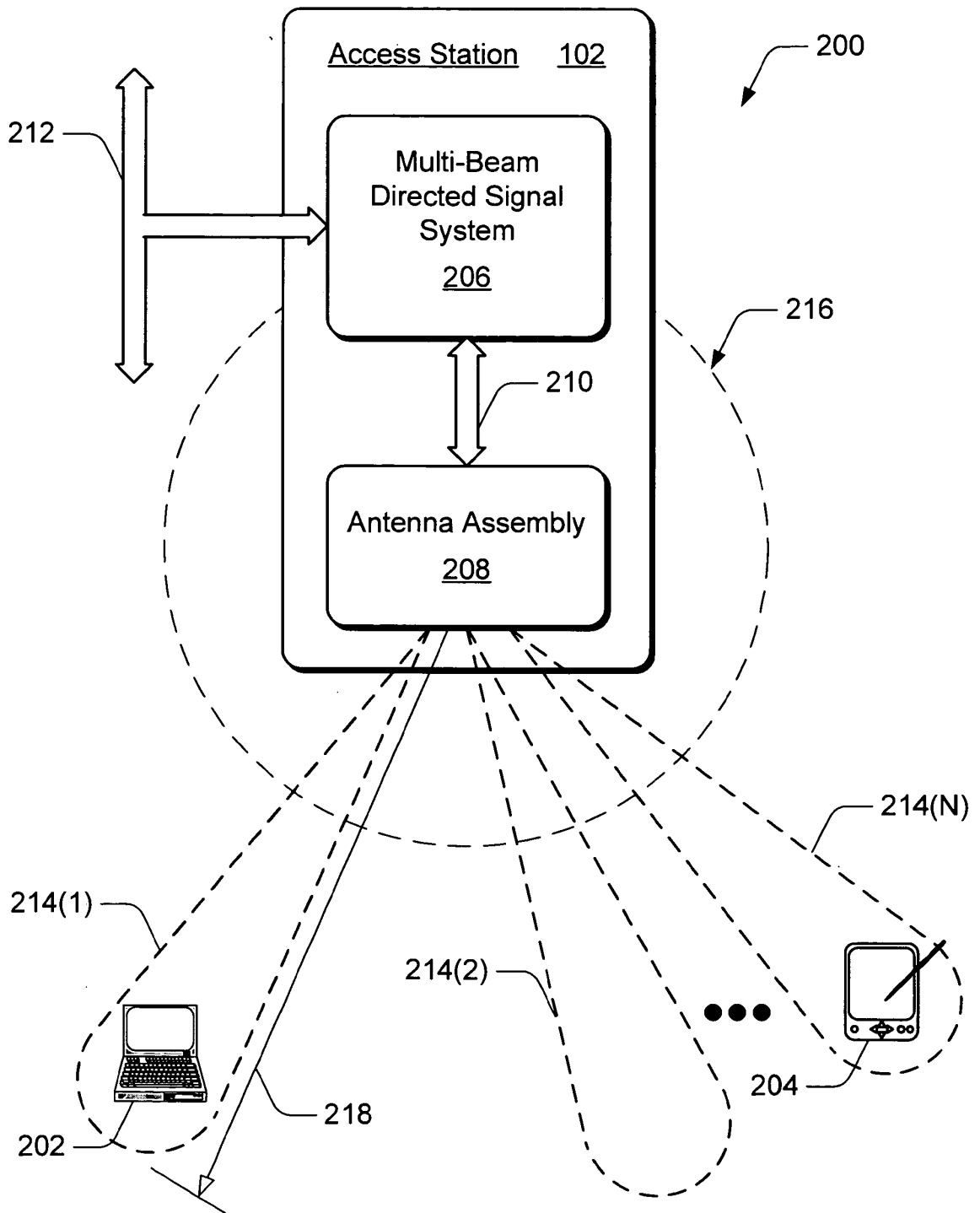
**DIRECTED WIRELESS COMMUNICATION****ABSTRACT**

Disclosed herein are methods and apparatuses configured to direct wireless communication. In some embodiments, a network apparatus is configured to: receive a first signal transmission from a remote station via a first antenna element of an antenna and a second signal transmission from the remote station via a second antenna element of the antenna simultaneously; determine first signal information for the first transmission; determine second signal information for the second transmission, wherein the second signal information is different than the first signal information; determine a set of weighting values based on the first signal information and the second signal information, wherein the set of weighting values is configured to construct one or more beam-formed transmission signals; and generate the one or more beam-formed transmission signals based on the set of weighting values for transmission to the remote station.

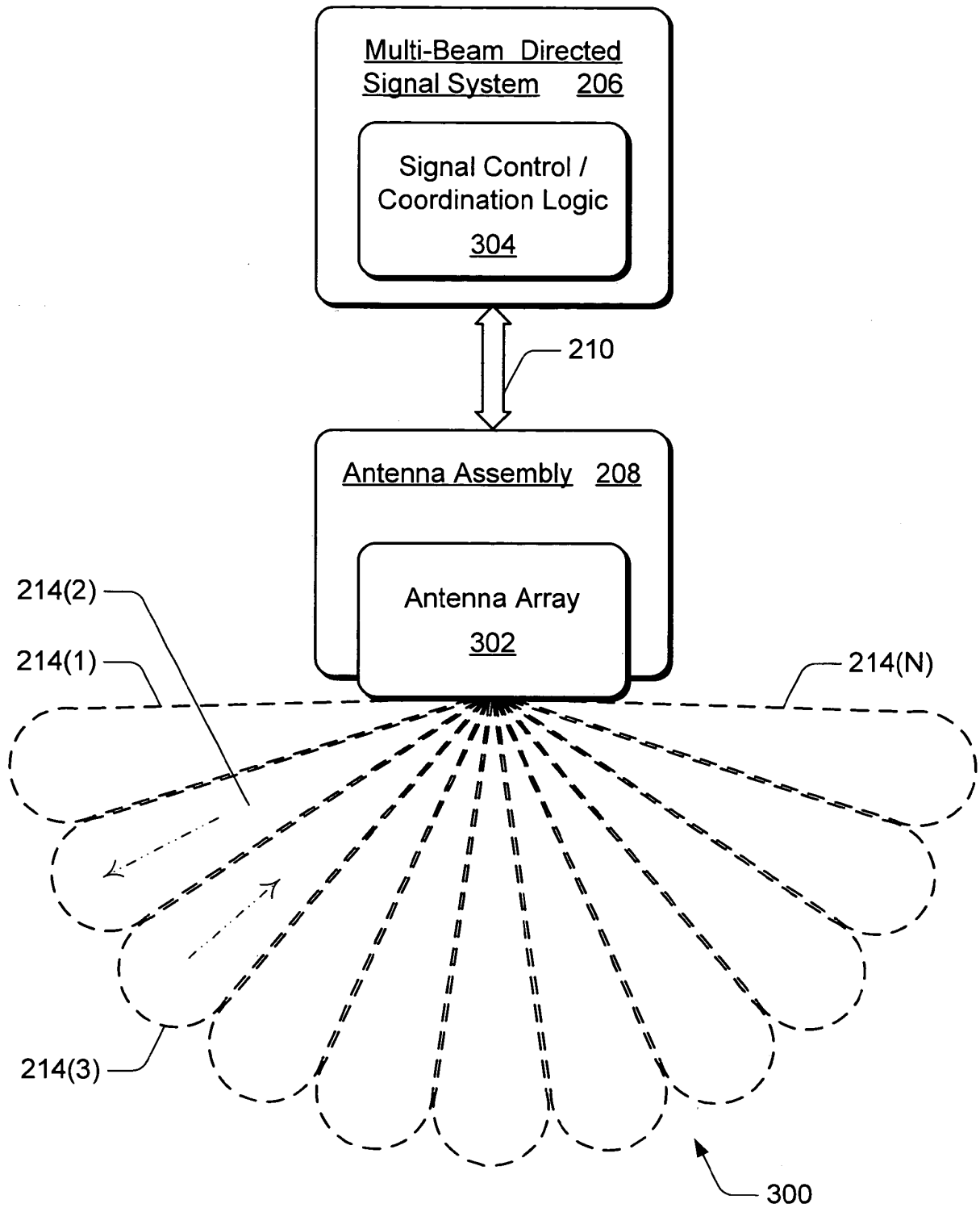


*Fig. 1*





*Fig. 2*



*Fig. 3*

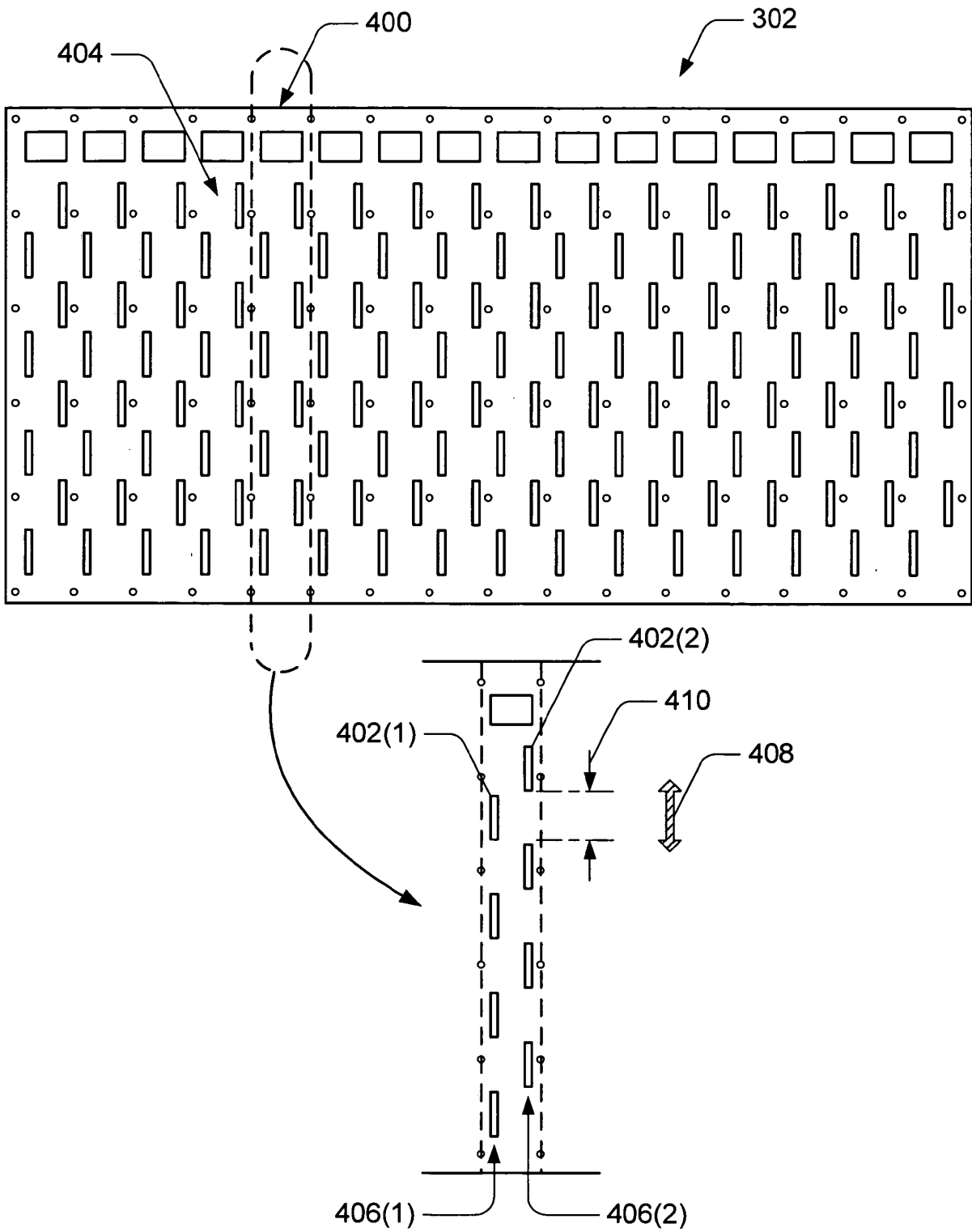


Fig. 4

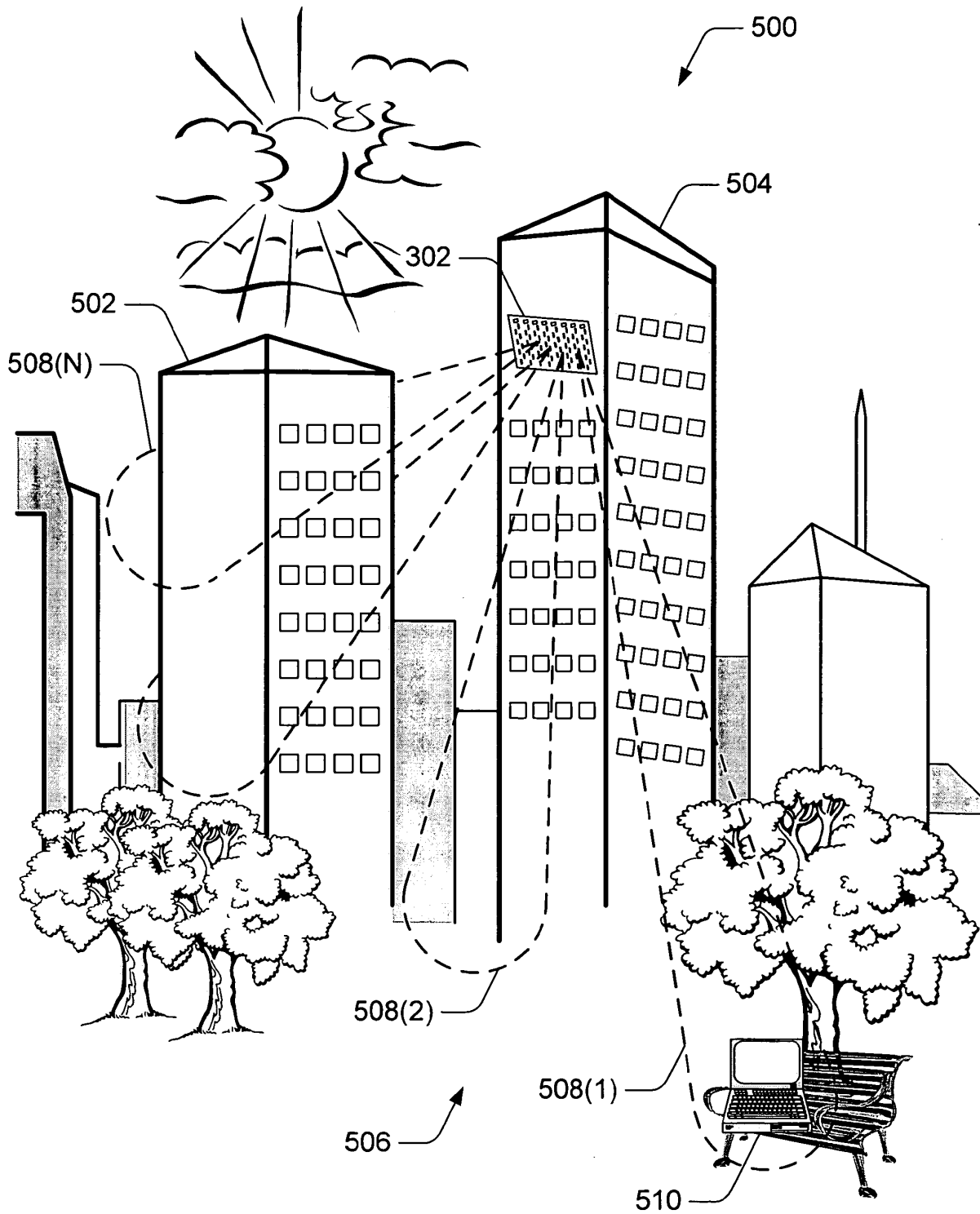
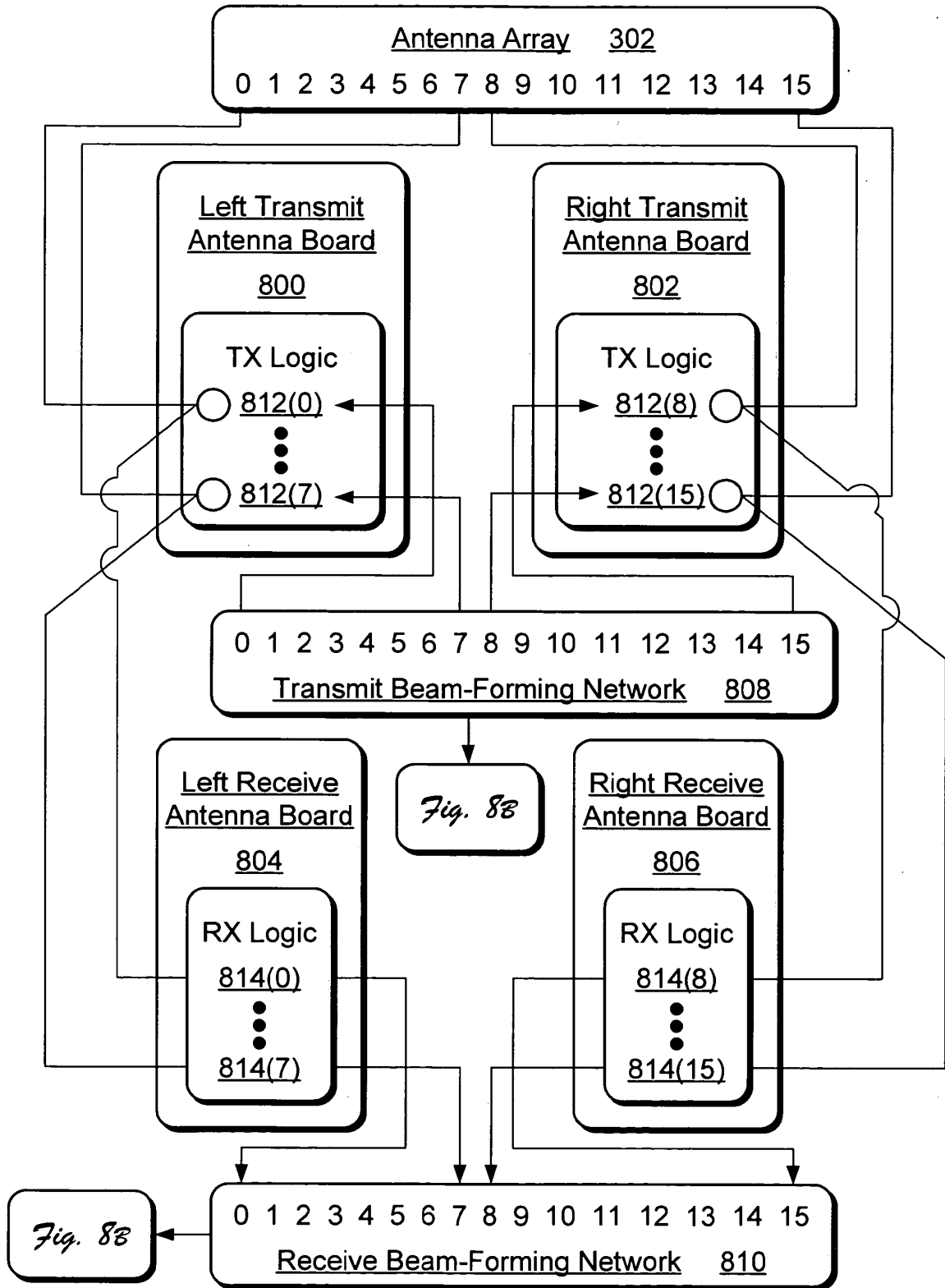
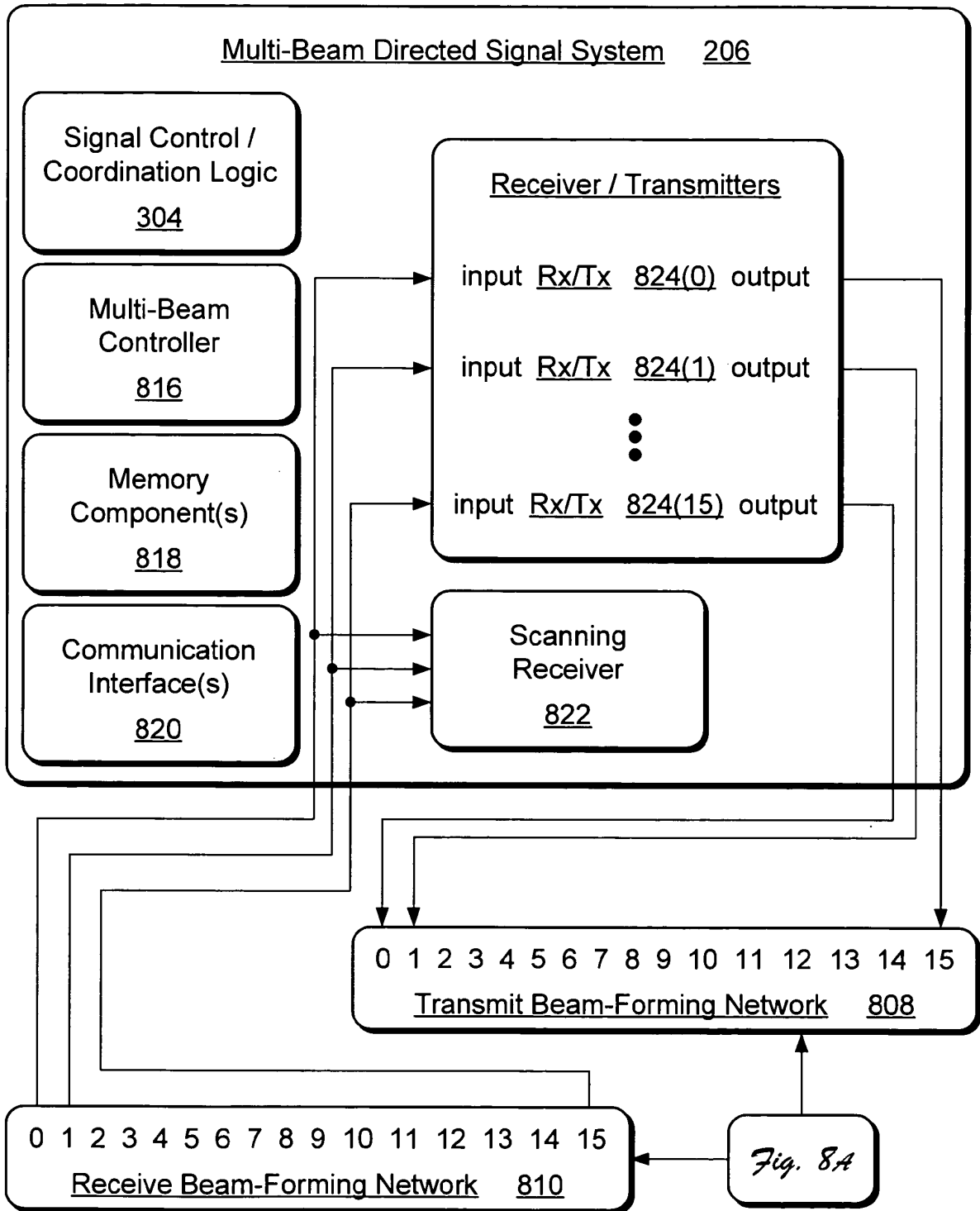


Fig. 5





*Fig. 8A*



*Fig. 8B*

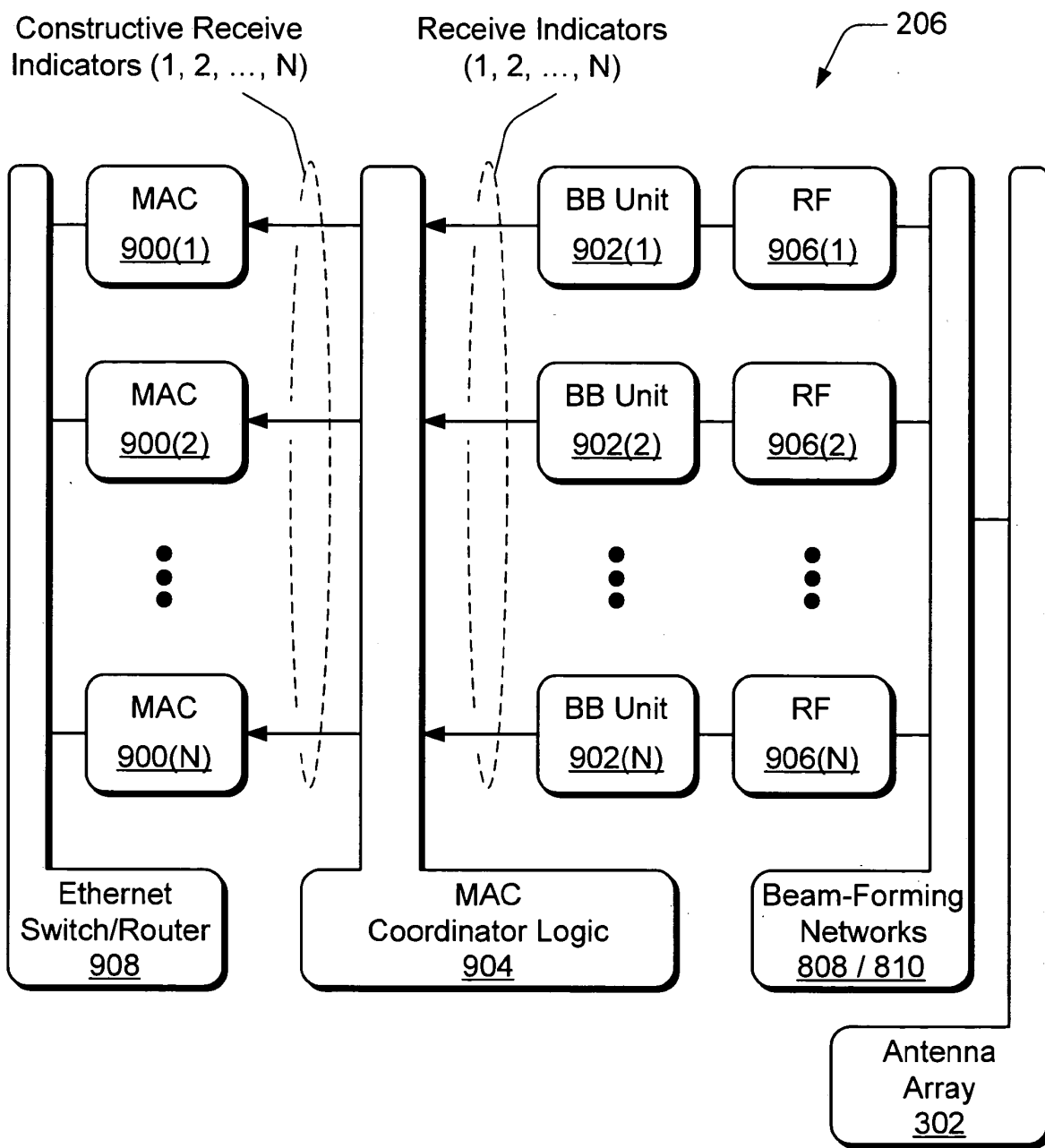


Fig. 9



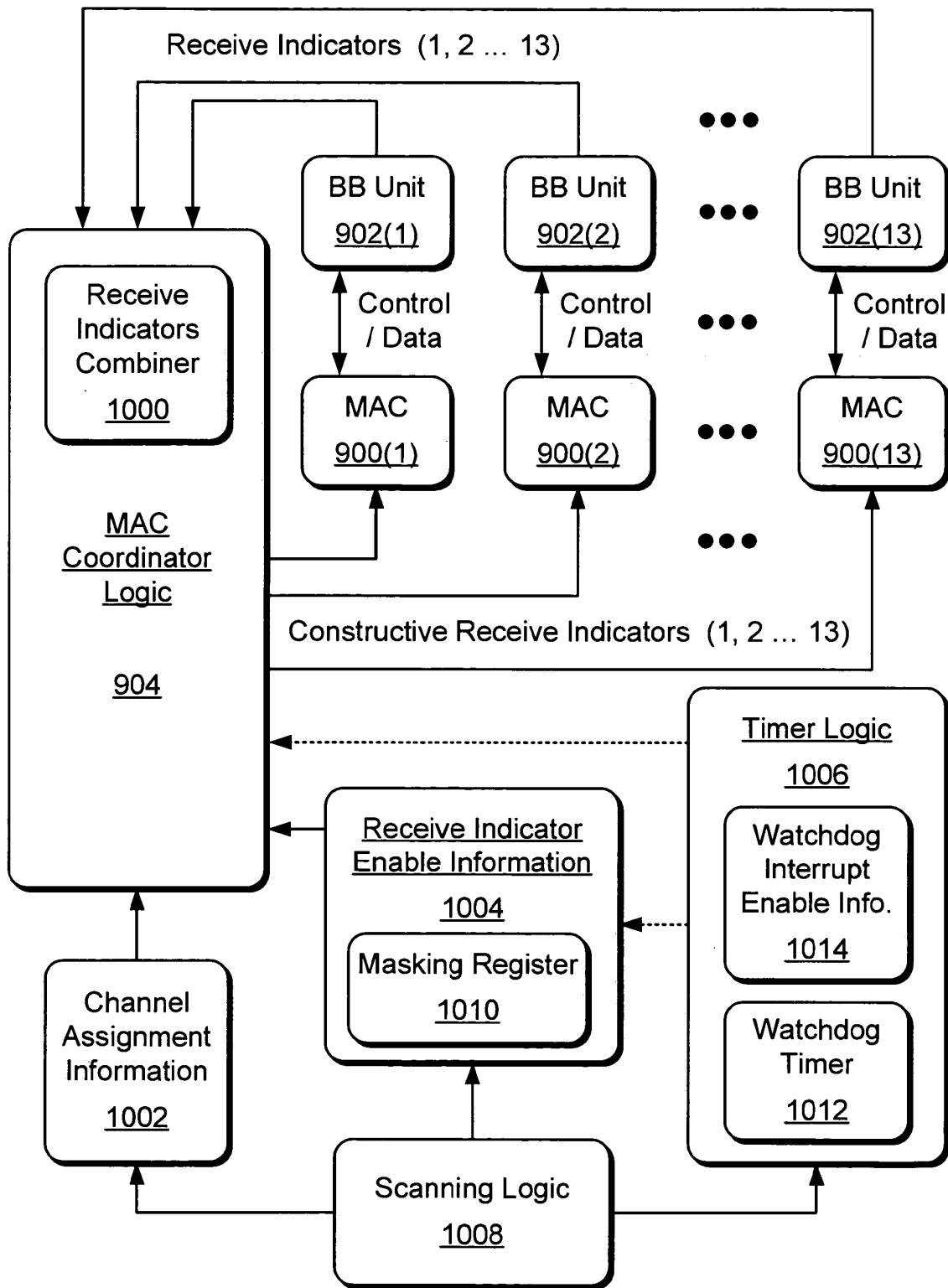


Fig. 10

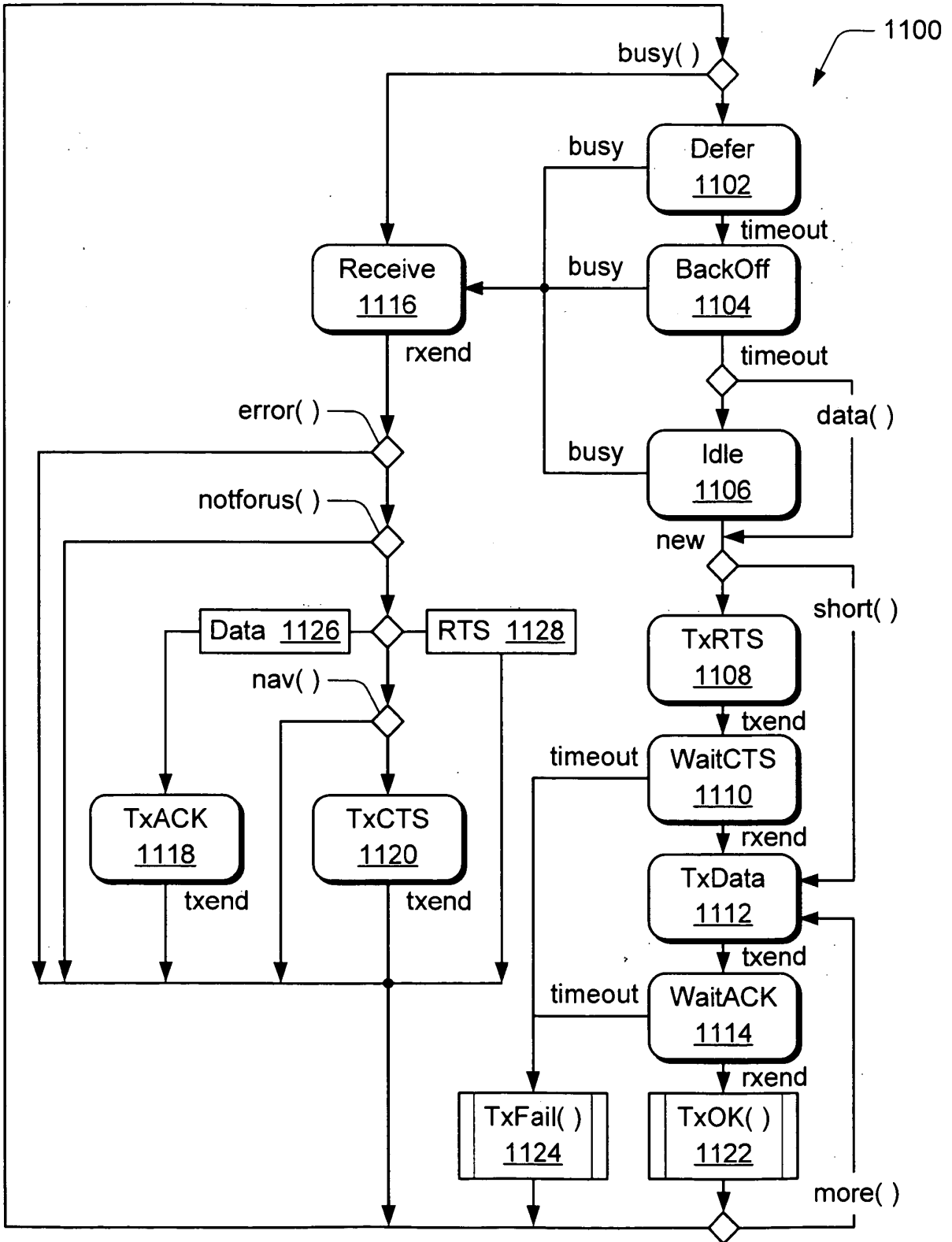


Fig. 11

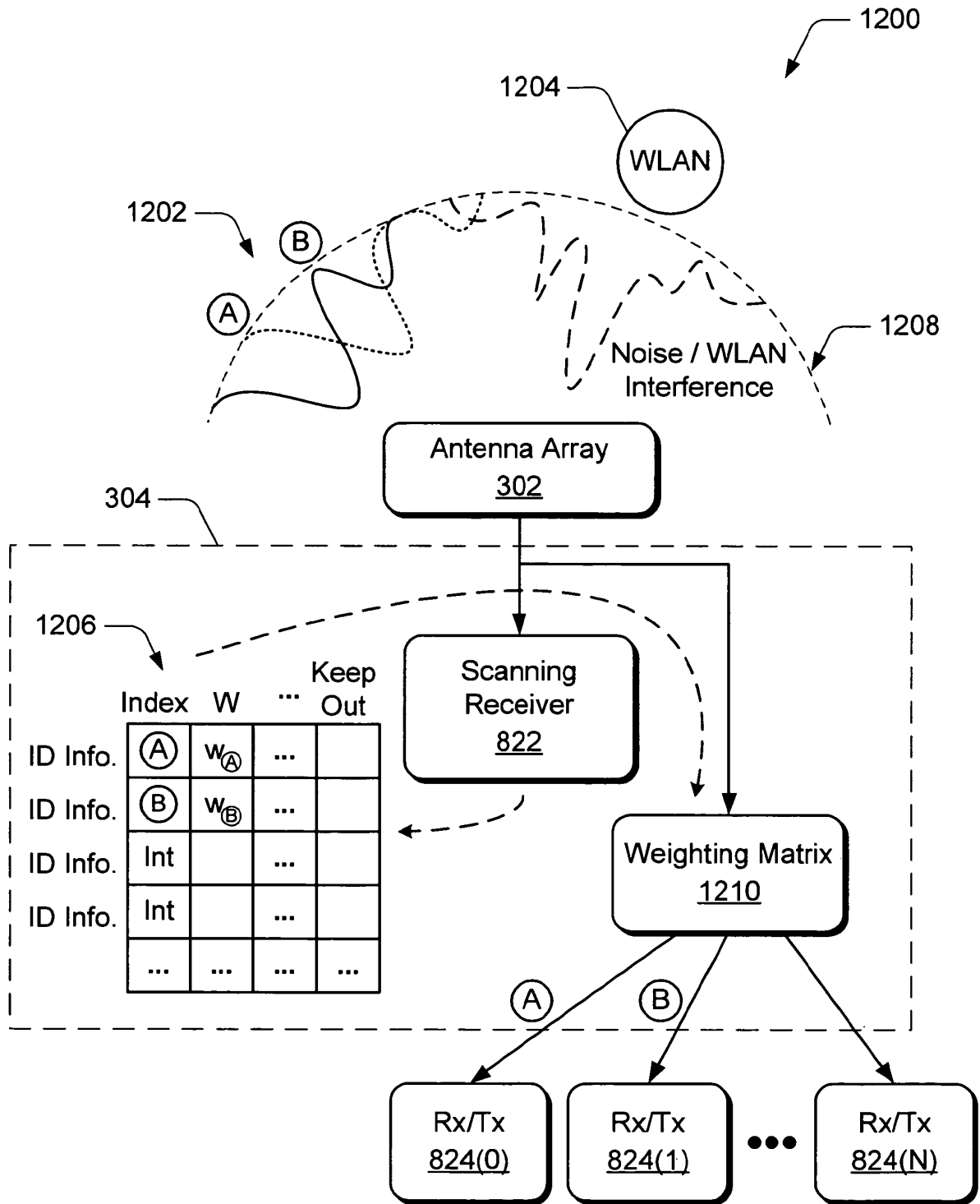
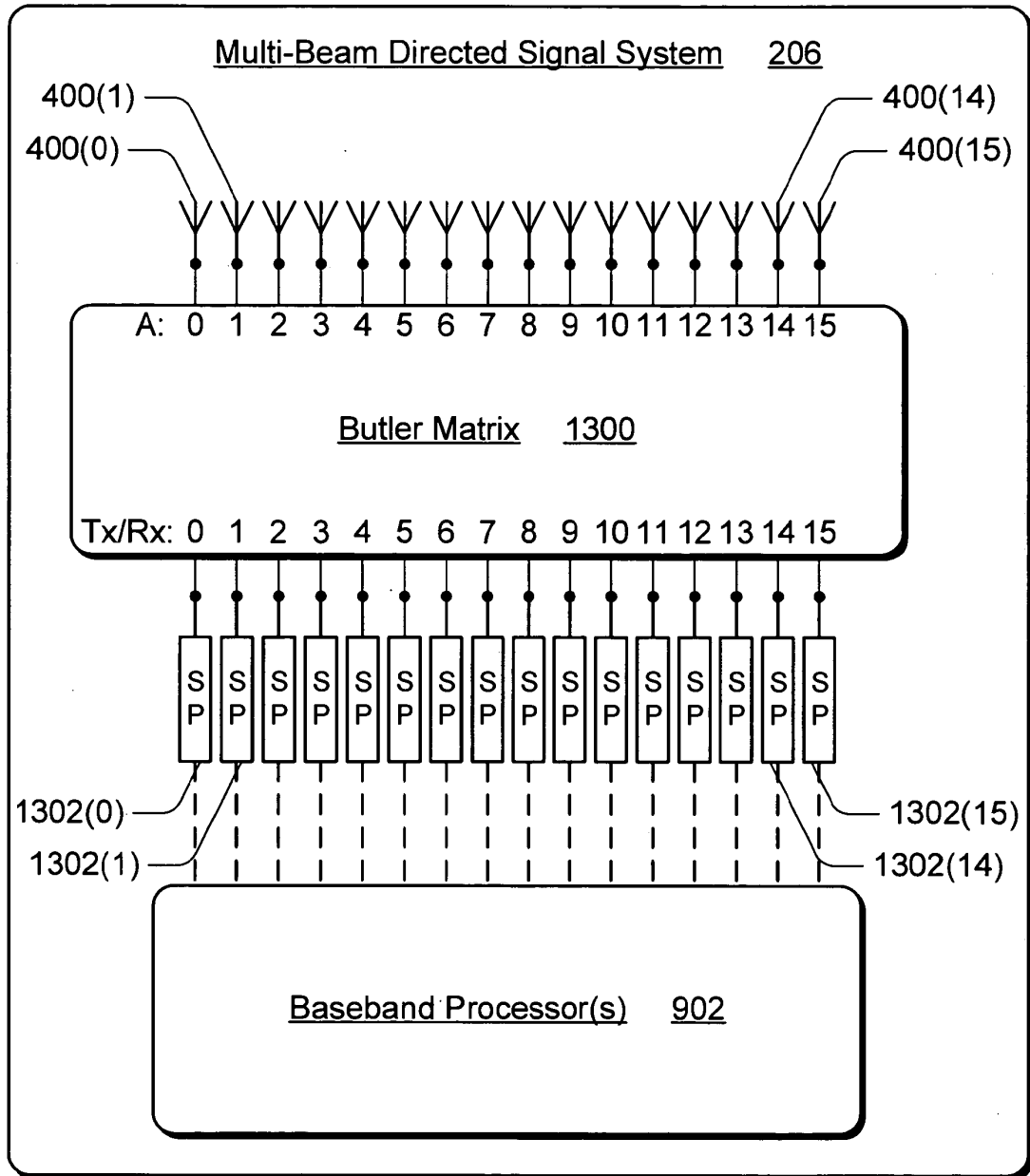


Fig. 12



*Fig. 13*

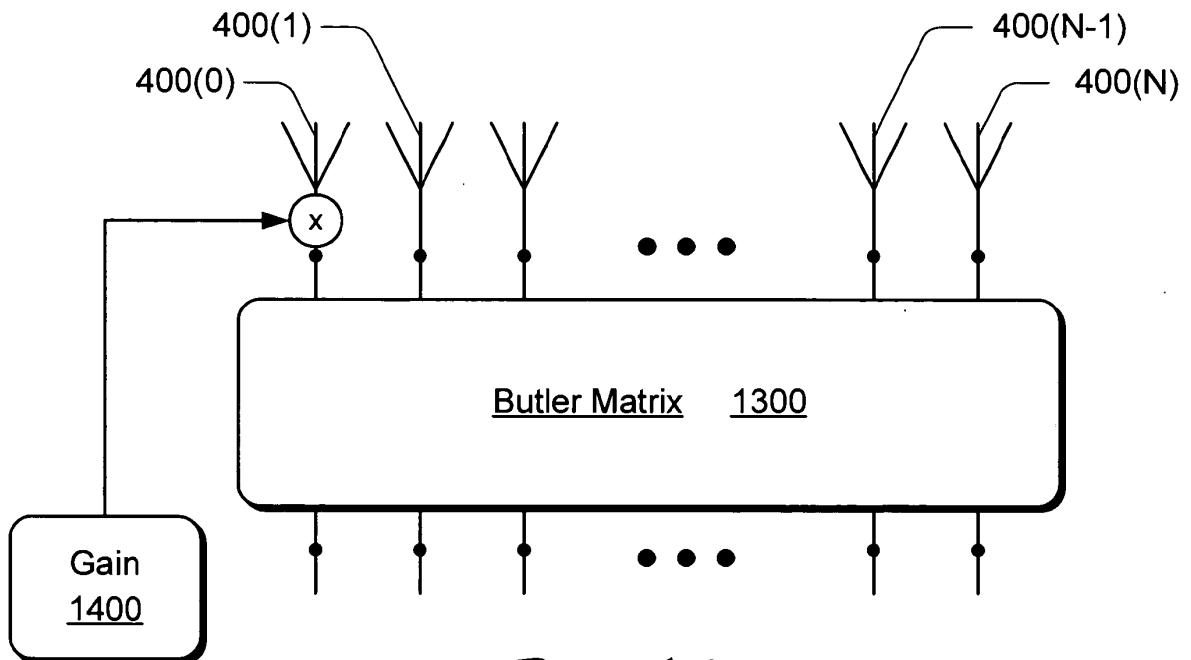


Fig. 14

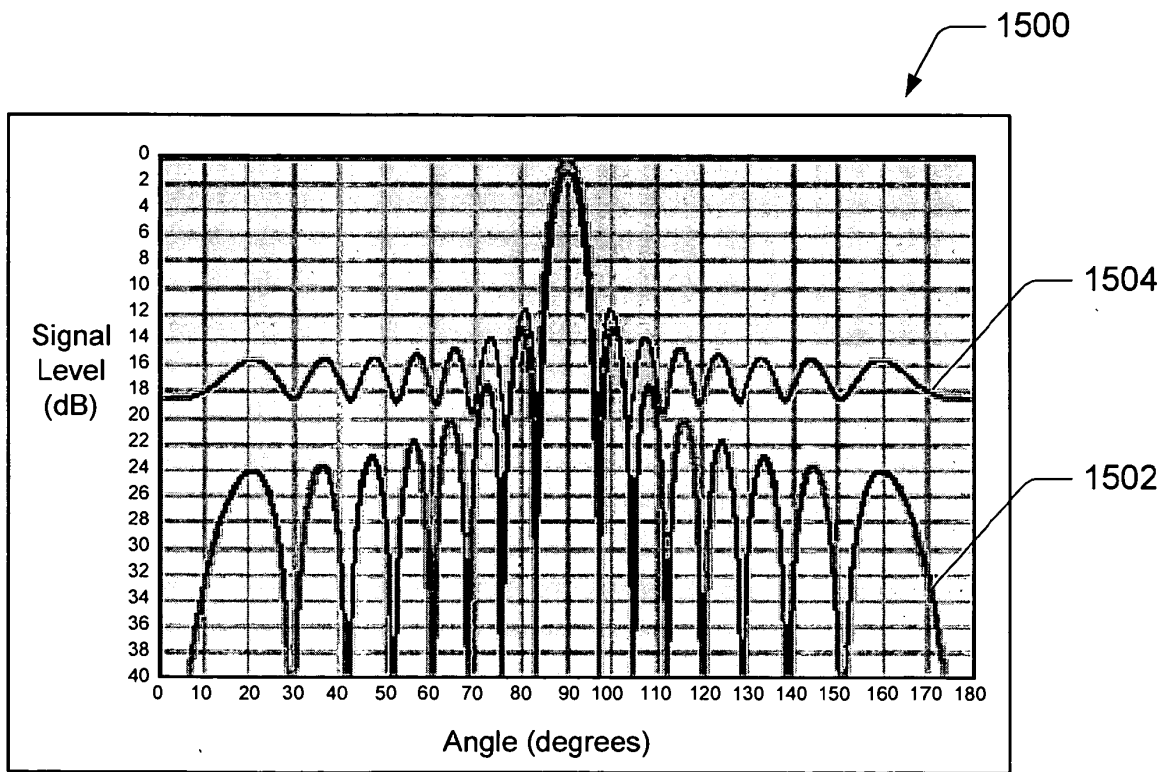


Fig. 15

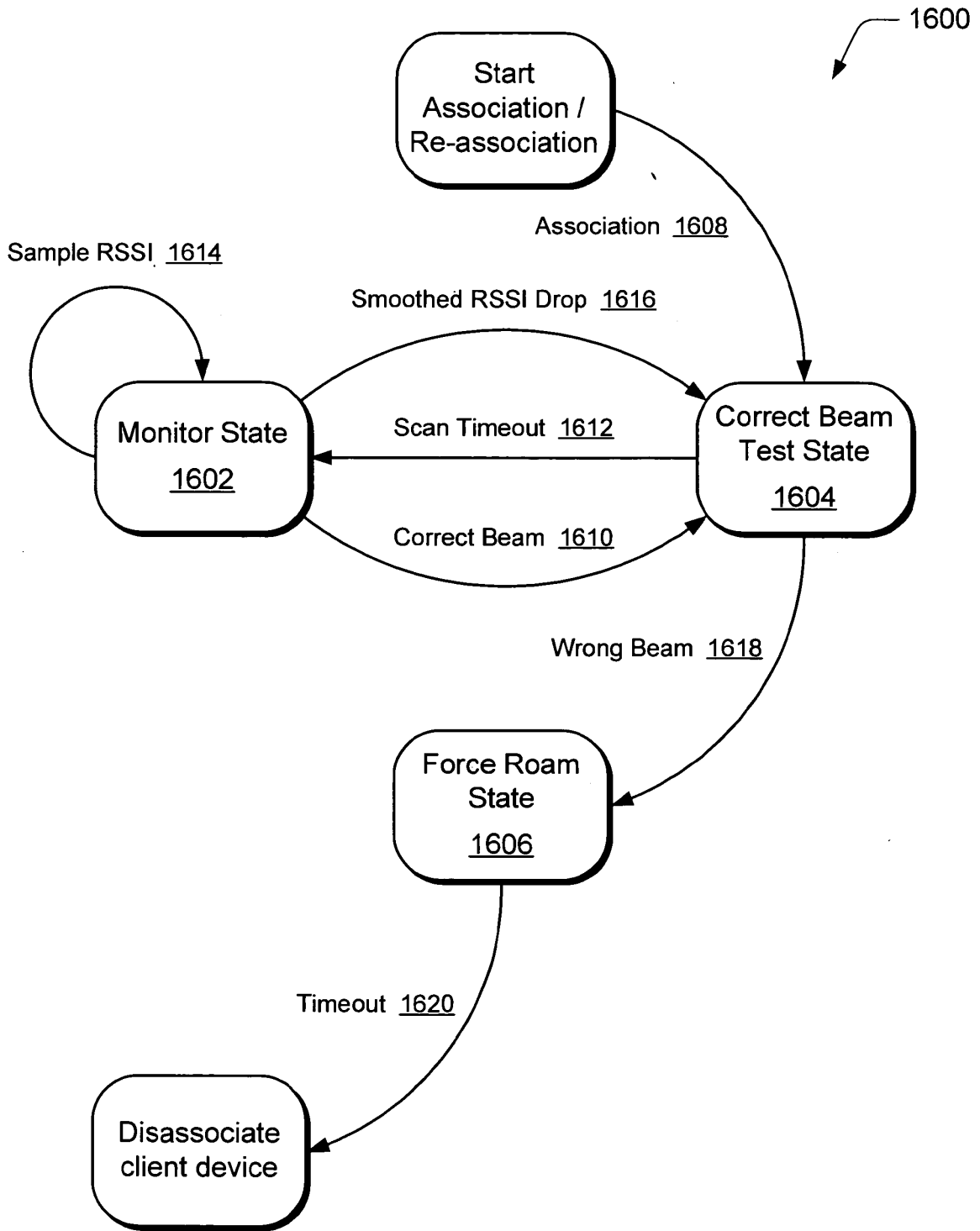
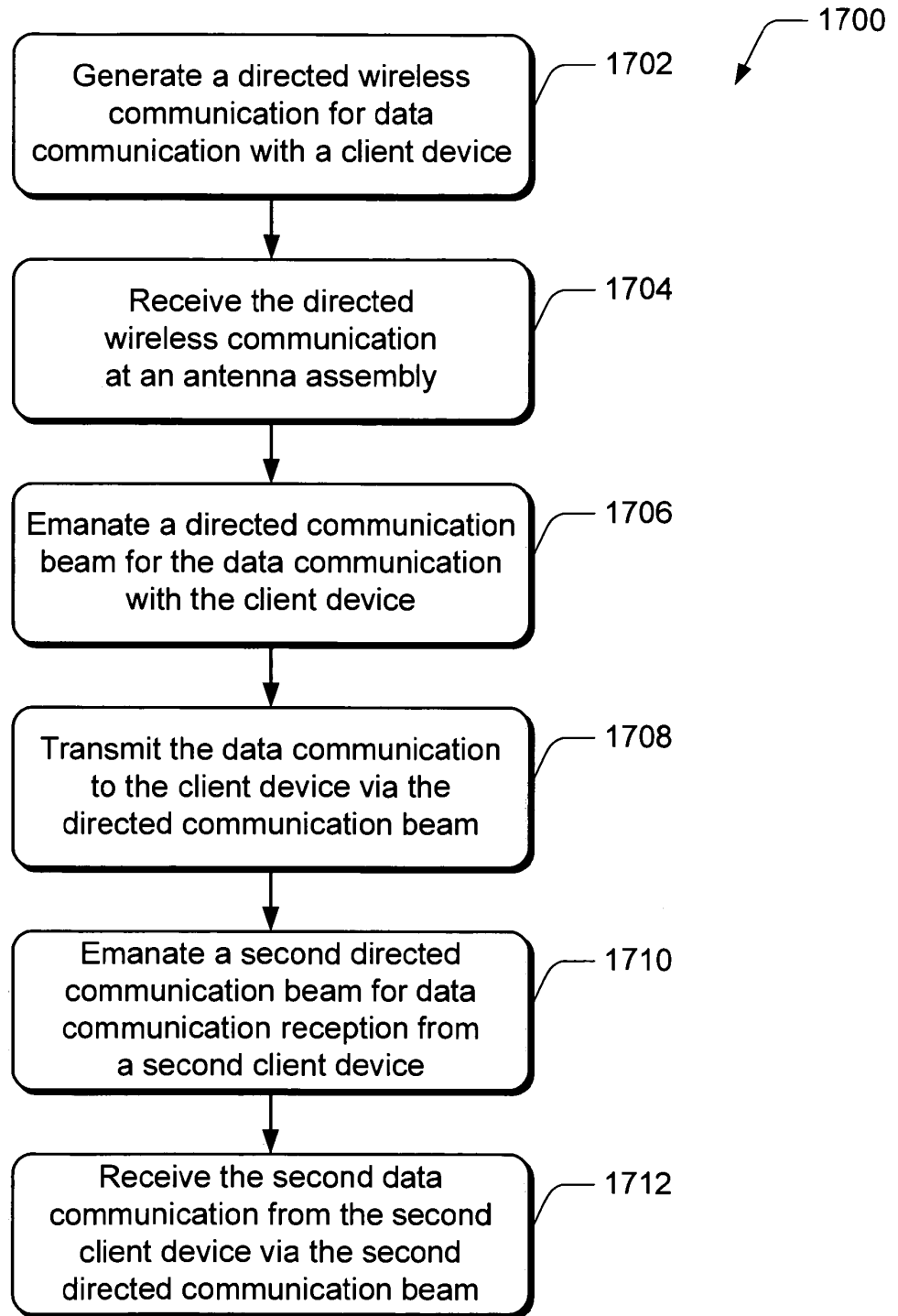
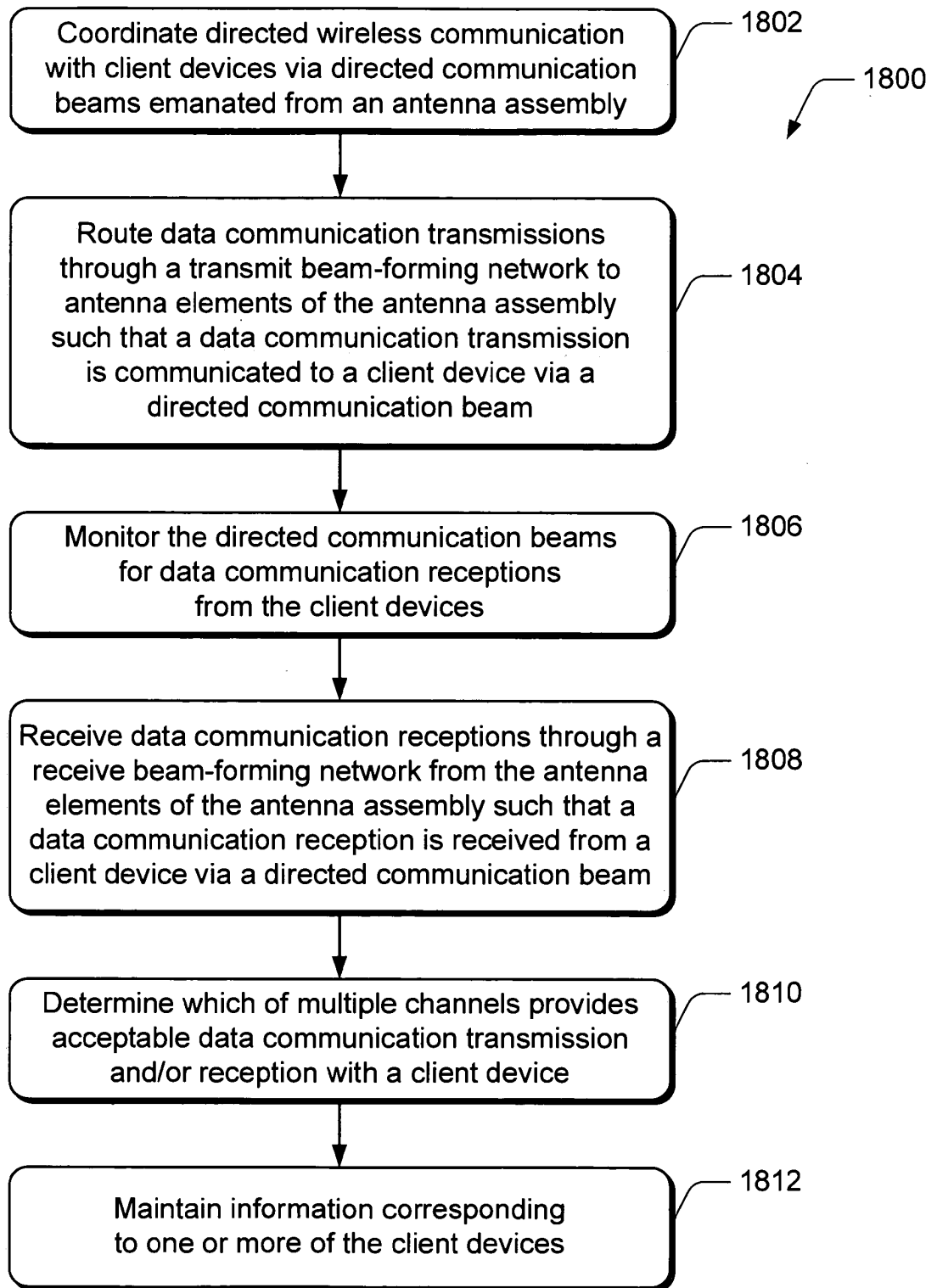


Fig. 16



*Fig. 17*

*Fig. 18*



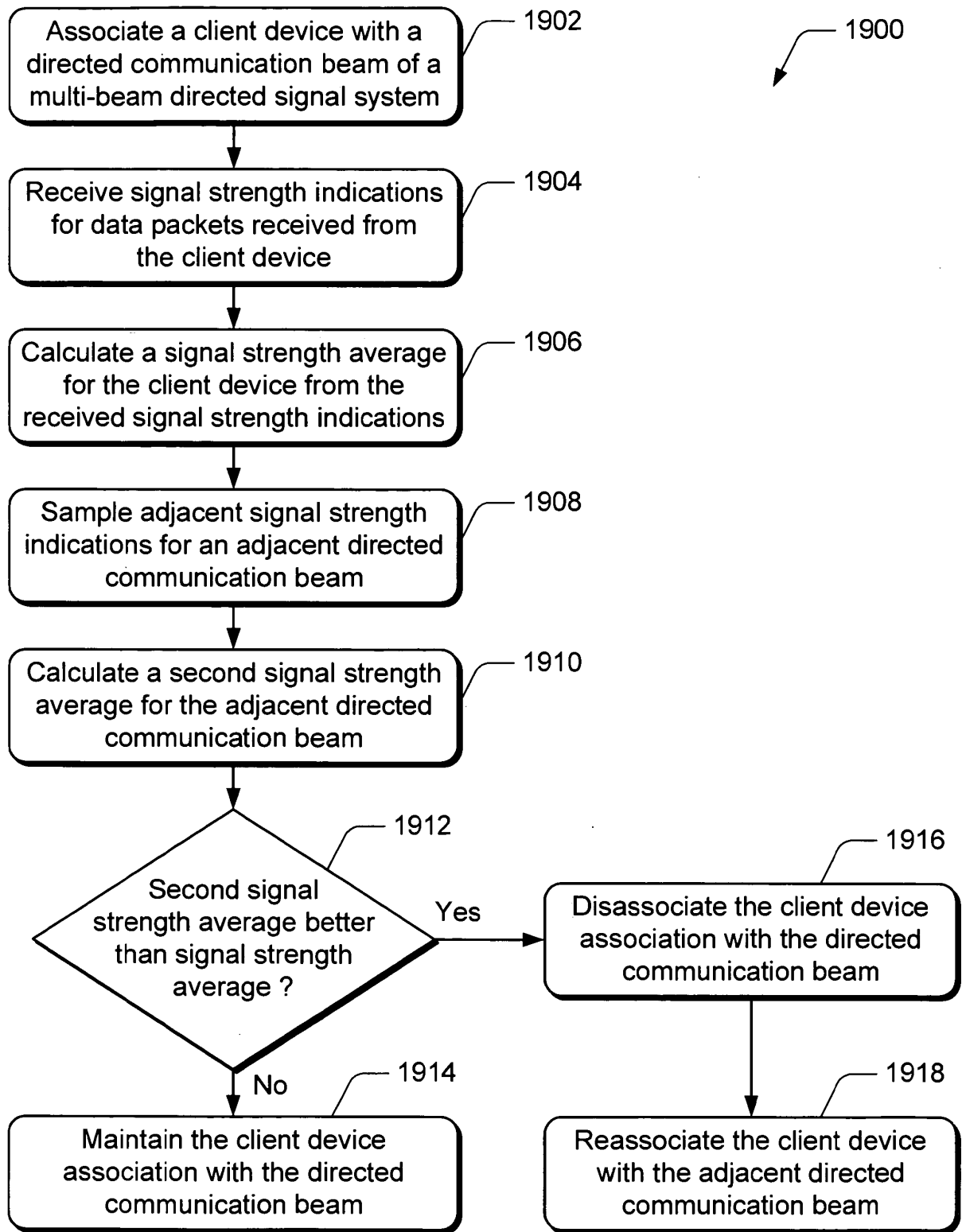


Fig. 19

**IN THE UNITED STATES PATENT AND TRADEMARK OFFICE**

Applicant:	XR Communications, LLC D/B/A Vivato Technologies
Application No.:	To be assigned
Filing Date:	Herewith
Title:	DIRECTED WIRELESS COMMUNICATION
Examiner:	To be assigned
Art Unit:	To be assigned
Confirmation No.:	To be assigned

**INFORMATION DISCLOSURE STATEMENT TRANSMITTAL**

Commissioner for Patents  
P.O. Box 1450  
Alexandria, VA 22313-1450

Dear Sir:

Pursuant to 37 C.F.R. § 1.56, 1.97 and 1.98, the attention of the United States Patent and Trademark Office is hereby directed to the references listed on the attached PTO/SB/08. It is respectfully requested that the information be expressly considered during the prosecution of the above-identified application, and that the references be made of record therein and appear among the "References Cited" on any patent to issue therefrom.

In accordance with 37 C.F.R. § 1.98(d)(1), certain foreign patent references and non-patent literature references listed on the attached PTO/SB/08, are not supplied here because they have become unavailable and because they were previously cited by or submitted to the Office in prior U.S. Application Number 15,260,147, filed September 8, 2016, in U.S. Application Number 13/855,410, filed April 2, 2013, and in U.S. Application Number 10/700,329, filed November 3, 2003, which are relied on for an earlier effective filing date under 35 U.S.C. 120 in the present application.



<p><b>INFORMATION DISCLOSURE STATEMENT BY APPLICANT</b> ( Not for submission under 37 CFR 1.99)</p>	Application Number		
	Filing Date		
	First Named Inventor	Marcus DA SILVA	
	Art Unit	TBD	
	Examiner Name	TBD	
	Attorney Docket Number	E1027.800(T).US1D1C1C3	

U.S.PATENTS						Remove
Examiner Initial*	Cite No	Patent Number	Kind Code <sup>1</sup>	Issue Date	Name of Patentee or Applicant of cited Document	Pages,Columns,Lines where Relevant Passages or Relevant Figures Appear
	1	4231040		1980-10-28	Walker	
	2	5327143		1994-07-05	Goetz et al.	
	3	5771017		1998-06-23	Dean et al.	
	4	5809141		1998-09-15	Dent et al.	
	5	5987037		1999-11-16	Gans	
	6	6049307		2000-04-11	Lim	
	7	6091788		2000-07-18	Keskitalo et al.	
	8	6104935		2000-08-15	Smith et al.	

**INFORMATION DISCLOSURE  
STATEMENT BY APPLICANT**  
( Not for submission under 37 CFR 1.99)

Application Number		
Filing Date		
First Named Inventor	Marcus DA SILVA	
Art Unit	TBD	
Examiner Name	TBD	
Attorney Docket Number	E1027.800(T).US1D1C1C3	

9	6108323		2000-08-22	Gray
10	6141335		2000-10-31	Kuwahara et al.
11	6169910		2001-01-02	Tamil et al.
12	6311075		2001-10-30	Bevan et al.
13	6337659		2002-01-08	Kim
14	6438376		2002-08-20	Elliott et al.
15	6470195		2002-10-22	Meyer
16	6611695		2003-08-26	Periyalwar
17	6628235		2003-09-30	Wight
18	6631277		2003-10-07	Berg et al.
19	6850741		2005-02-01	Lei et al.

<b>INFORMATION DISCLOSURE STATEMENT BY APPLICANT</b> ( Not for submission under 37 CFR 1.99)	Application Number			
	Filing Date			
	First Named Inventor	Marcus DA SILVA		
	Art Unit	TBD		
	Examiner Name	TBD		
	Attorney Docket Number	E1027.800(T).US1D1C1C3		

20	6907269		2005-06-14	Yamaguchi et al.
21	7346365		2008-03-18	Hovers et al.
22	9462589	B2	2016-10-04	DA SILVA

If you wish to add additional U.S. Patent citation information please click the Add button.

Add

**U.S.PATENT APPLICATION PUBLICATIONS**

Remove

Examiner Initial*	Cite No	Publication Number	Kind Code <sup>1</sup>	Publication Date	Name of Patentee or Applicant of cited Document	Pages, Columns, Lines where Relevant Passages or Relevant Figures Appear
	1	20010033600	A1	2001-10-25	Yang et al.	
	2	20020103013	A1	2002-08-01	Watson et al.	
	3	20020158801	A1	2002-10-31	Crilly et al.	
	4	20030064752	A1	2003-04-03	Adachi et al.	
	5	20030073465	A1	2003-04-17	Li	
	6	20030114196	A1	2003-06-19	Chitrapu	

<b>INFORMATION DISCLOSURE STATEMENT BY APPLICANT</b> ( Not for submission under 37 CFR 1.99)	Application Number		
	Filing Date		
	First Named Inventor	Marcus DA SILVA	
	Art Unit	TBD	
	Examiner Name	TBD	
	Attorney Docket Number	E1027.800(T).US1D1C1C3	

	7	20040063468	A1	2004-04-01	Frank	
--	---	-------------	----	------------	-------	--

If you wish to add additional U.S. Published Application citation information please click the Add button.

**FOREIGN PATENT DOCUMENTS**

Examiner Initial*	Cite No	Foreign Document Number <sup>3</sup>	Country Code <sup>2</sup> i	Kind Code <sup>4</sup>	Publication Date	Name of Patentee or Applicant of cited Document	Pages, Columns, Lines where Relevant Passages or Relevant Figures Appear	T <sup>5</sup>
	1	9921391	WO	A2	1999-04-29	Radio Design Innovation Tj Ab		

If you wish to add additional Foreign Patent Document citation information please click the Add button.

**NON-PATENT LITERATURE DOCUMENTS**

Examiner Initials*	Cite No	Include name of the author (in CAPITAL LETTERS), title of the article (when appropriate), title of the item (book, magazine, journal, serial, symposium, catalog, etc), date, pages(s), volume-issue number(s), publisher, city and/or country where published.	T <sup>5</sup>
	1	Anastasi, et. al., "MAC Protocols for Widcband Wireless Local Access: Evolution Towards Wireless ATM", IEEE Personal Communications Magazine, pp. 53-64, Oct. 1998.	
	2	Berg, J., "Building penetration loss along urban street microcells," in Proceedings of PIMRC '96--7th International Symposium on Personal, Indoor, and Mobile Communications, 3:795-797 (1996).	
	3	Damoss, E. and L. Correia, eds., COST 231 Final Report--Digital Mobile Radio--Towards Future Generation Systems. European Commission, Directorate General XIII, Report No. RJR 18957 (ISBN 92-828-54167), 516 pages (1999).	
	4	Deng, S., "Empirical Model of WWW Document Arrivals at Access Link," Communications, 1996. ICC '96, Conference Record, Converging Technologies for Tomorrow's Applications. 1996 IEEE International Conference, 197-202 (1996).	
	5	Gans et al., "High data rate indoor wireless communications using antenna arrays," in Proceedings of 6th International Symposium on Personal, Indoor and Mobile Radio Communications, 3:1040-1046 (1995).	

<b>INFORMATION DISCLOSURE STATEMENT BY APPLICANT ( Not for submission under 37 CFR 1.99)</b>	Application Number		
	Filing Date		
	First Named Inventor	Marcus DA SILVA	
	Art Unit	TBD	
	Examiner Name	TBD	
	Attorney Docket Number	E1027.800(T).US1D1C1C3	

6	German et al., "Wireless Indoor Channel Modeling: Statistical Agreement of Ray Tracing Simulations and Channel Sounding Measurements," in Proceeding of 2001 IEEE International Conference on Acoustics, Speech, and Signal Processing, 4:2501-2504 (2001).
7	Gucsalla, R., "Characterizing the Variability of Arrival Processes with Indexes of Dispersion", IEEE JSAC, 9(2):203-211 (1990).
8	Hashemi, H., "The Indoor Propagation Channel," Proceedings of the IEEE, 81 (7): 943-968 (1993).
9	Jakes, W.C., ed., Microwave Mobile Communications. Wiley, 1974. 645 pages.
10	Kivinen et al., "Empirical Characterization of Wide band Indoor radio Channel at 5.3 GHz," IEEE Transactions on Antennas and Propagation, 49(8): 1192-1203 (2001).
11	Leland et. Al., "On the Self-Similar Nature of Ethernet Traffic," IEEE/ACM Transactions on Networking, 2(1):1-15 (1994).
12	Medbo, J. and J. Berg, "Simple and accurate path loss modeling at 5 GHz in indoor environments with corridors," in Vehicular Technology Conference Fall 2000. IEEE VTS Fall VTC2000. 52nd Vehicular Technology Conference, 1:30-36 (2000).

If you wish to add additional non-patent literature document citation information please click the Add button

**EXAMINER SIGNATURE**

Examiner Signature		Date Considered	
--------------------	--	-----------------	--

\*EXAMINER: Initial if reference considered, whether or not citation is in conformance with MPEP 609. Draw line through a citation if not in conformance and not considered. Include copy of this form with next communication to applicant.

<sup>1</sup> See Kind Codes of USPTO Patent Documents at [www.USPTO.GOV](http://www.USPTO.GOV) or MPEP 901.04. <sup>2</sup> Enter office that issued the document, by the two-letter code (WIPO Standard ST.3). <sup>3</sup> For Japanese patent documents, the indication of the year of the reign of the Emperor must precede the serial number of the patent document. <sup>4</sup> Kind of document by the appropriate symbols as indicated on the document under WIPO Standard ST.16 if possible. <sup>5</sup> Applicant is to place a check mark here if English language translation is attached.



<b>INFORMATION DISCLOSURE STATEMENT BY APPLICANT</b> ( Not for submission under 37 CFR 1.99)	Application Number		
	Filing Date		
	First Named Inventor	Marcus DA SILVA	
	Art Unit	TBD	
	Examiner Name	TBD	
	Attorney Docket Number	E1027.800(T).US1D1C1C3	

**CERTIFICATION STATEMENT**

Please see 37 CFR 1.97 and 1.98 to make the appropriate selection(s):

That each item of information contained in the information disclosure statement was first cited in any communication from a foreign patent office in a counterpart foreign application not more than three months prior to the filing of the information disclosure statement. See 37 CFR 1.97(e)(1).

**OR**

That no item of information contained in the information disclosure statement was cited in a communication from a foreign patent office in a counterpart foreign application, and, to the knowledge of the person signing the certification after making reasonable inquiry, no item of information contained in the information disclosure statement was known to any individual designated in 37 CFR 1.56(c) more than three months prior to the filing of the information disclosure statement. See 37 CFR 1.97(e)(2).

See attached certification statement.

The fee set forth in 37 CFR 1.17 (p) has been submitted herewith.

A certification statement is not submitted herewith.

**SIGNATURE**

A signature of the applicant or representative is required in accordance with CFR 1.33, 10.18. Please see CFR 1.4(d) for the form of the signature.

Signature	/Nicholas R. Transier/	Date (YYYY-MM-DD)	2017-04-24
Name/Print	Nicholas R. TRANSIER	Registration Number	68743

This collection of information is required by 37 CFR 1.97 and 1.98. The information is required to obtain or retain a benefit by the public which is to file (and by the USPTO to process) an application. Confidentiality is governed by 35 U.S.C. 122 and 37 CFR 1.14. This collection is estimated to take 1 hour to complete, including gathering, preparing and submitting the completed application form to the USPTO. Time will vary depending upon the individual case. Any comments on the amount of time you require to complete this form and/or suggestions for reducing this burden, should be sent to the Chief Information Officer, U.S. Patent and Trademark Office, U.S. Department of Commerce, P.O. Box 1450, Alexandria, VA 22313-1450. **DO NOT SEND FEES OR COMPLETED FORMS TO THIS ADDRESS. SEND TO: Commissioner for Patents, P.O. Box 1450, Alexandria, VA 22313-1450.**

## Privacy Act Statement

The Privacy Act of 1974 (P.L. 93-579) requires that you be given certain information in connection with your submission of the attached form related to a patent application or patent. Accordingly, pursuant to the requirements of the Act, please be advised that: (1) the general authority for the collection of this information is 35 U.S.C. 2(b)(2); (2) furnishing of the information solicited is voluntary; and (3) the principal purpose for which the information is used by the U.S. Patent and Trademark Office is to process and/or examine your submission related to a patent application or patent. If you do not furnish the requested information, the U.S. Patent and Trademark Office may not be able to process and/or examine your submission, which may result in termination of proceedings or abandonment of the application or expiration of the patent.

The information provided by you in this form will be subject to the following routine uses:

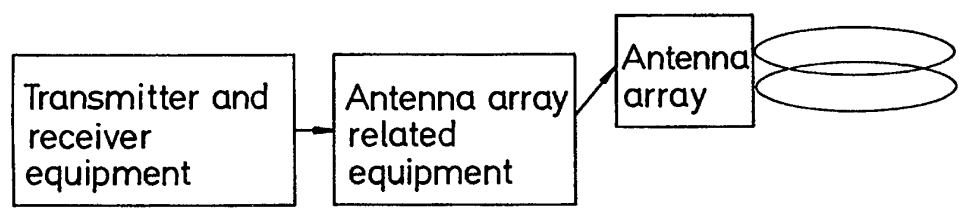
1. The information on this form will be treated confidentially to the extent allowed under the Freedom of Information Act (5 U.S.C. 552) and the Privacy Act (5 U.S.C. 552a). Records from this system of records may be disclosed to the Department of Justice to determine whether the Freedom of Information Act requires disclosure of these records.
2. A record from this system of records may be disclosed, as a routine use, in the course of presenting evidence to a court, magistrate, or administrative tribunal, including disclosures to opposing counsel in the course of settlement negotiations.
3. A record in this system of records may be disclosed, as a routine use, to a Member of Congress submitting a request involving an individual, to whom the record pertains, when the individual has requested assistance from the Member with respect to the subject matter of the record.
4. A record in this system of records may be disclosed, as a routine use, to a contractor of the Agency having need for the information in order to perform a contract. Recipients of information shall be required to comply with the requirements of the Privacy Act of 1974, as amended, pursuant to 5 U.S.C. 552a(m).
5. A record related to an International Application filed under the Patent Cooperation Treaty in this system of records may be disclosed, as a routine use, to the International Bureau of the World Intellectual Property Organization, pursuant to the Patent Cooperation Treaty.
6. A record in this system of records may be disclosed, as a routine use, to another federal agency for purposes of National Security review (35 U.S.C. 181) and for review pursuant to the Atomic Energy Act (42 U.S.C. 218(c)).
7. A record from this system of records may be disclosed, as a routine use, to the Administrator, General Services, or his/her designee, during an inspection of records conducted by GSA as part of that agency's responsibility to recommend improvements in records management practices and programs, under authority of 44 U.S.C. 2904 and 2906. Such disclosure shall be made in accordance with the GSA regulations governing inspection of records for this purpose, and any other relevant (i.e., GSA or Commerce) directive. Such disclosure shall not be used to make determinations about individuals.
8. A record from this system of records may be disclosed, as a routine use, to the public after either publication of the application pursuant to 35 U.S.C. 122(b) or issuance of a patent pursuant to 35 U.S.C. 151. Further, a record may be disclosed, subject to the limitations of 37 CFR 1.14, as a routine use, to the public if the record was filed in an application which became abandoned or in which the proceedings were terminated and which application is referenced by either a published application, an application open to public inspections or an issued patent.
9. A record from this system of records may be disclosed, as a routine use, to a Federal, State, or local law enforcement agency, if the USPTO becomes aware of a violation or potential violation of law or regulation.



INTERNATIONAL APPLICATION PUBLISHED UNDER THE PATENT COOPERATION TREATY (PCT)

<p>(51) International Patent Classification <sup>6</sup> : <b>H04Q 7/38</b></p>	<p><b>A2</b></p>	<p>(11) International Publication Number: <b>WO 99/21391</b> (43) International Publication Date: 29 April 1999 (29.04.99)</p>
<p>(21) International Application Number: PCT/SE98/01891 (22) International Filing Date: 20 October 1998 (20.10.98) (30) Priority Data: 9703822-8 20 October 1997 (20.10.97) SE 9703823-6 20 October 1997 (20.10.97) SE 9800869-1 17 March 1998 (17.03.98) SE (71) Applicant (for all designated States except US): RADIO DESIGN INNOVATION TJ AB [SE/SE]; P.O. Box 1223, S-164 28 Kista (SE). (72) Inventors; and (75) Inventors/Applicants (for US only): ANDERSSON, Henrik [SE/SE]; Kungsholmsgatan 16, S-112 27 Stockholm (SE). ANDERMO, Per-Göran [SE/SE]; Stejerna väg 2, S-191 45 Sollentuna (SE). (74) Agent: ALBIHNS PATENTBYRÅ MALMÖ AB; P.O. Box 4289, S-203 14 Malmö (SE).</p>		<p>(81) Designated States: AL, AM, AT, AU, AZ, BA, BB, BG, BR, BY, CA, CH, CN, CU, CZ, DE, DK, EE, ES, FI, GB, GD, GE, GH, GM, HR, HU, ID, IL, IS, JP, KE, KG, KP, KR, KZ, LC, LK, LR, LS, LT, LU, LV, MD, MG, MK, MN, MW, MX, NO, NZ, PL, PT, RO, RU, SD, SE, SG, SI, SK, SL, TJ, TM, TR, TT, UA, UG, US, UZ, VN, YU, ZW, ARIPO patent (GH, GM, KE, LS, MW, SD, SZ, UG, ZW), Eurasian patent (AM, AZ, BY, KG, KZ, MD, RU, TJ, TM), European patent (AT, BE, CH, CY, DE, DK, ES, FI, FR, GB, GR, IE, IT, LU, MC, NL, PT, SE), OAPI patent (BF, BJ, CF, CG, CI, CM, GA, GN, GW, ML, MR, NE, SN, TD, TG).  <b>Published</b> <i>Without international search report and to be republished upon receipt of that report.</i></p>

(54) Title: SEAMLESS LOBE HANDOVER



(57) Abstract  
The present invention relates to a method in a telecommunication system for communication between mobile stations and base station sites in the telecommunication system. The mobile stations in said telecommunication system, preferably a cellular mobile radio system, move within a site on the same channel by use of seamless lobe or sector handover.

**FOR THE PURPOSES OF INFORMATION ONLY**

Codes used to identify States party to the PCT on the front pages of pamphlets publishing international applications under the PCT.

<b>AL</b>	Albania	<b>ES</b>	Spain	<b>LS</b>	Lesotho	<b>SI</b>	Slovenia
<b>AM</b>	Armenia	<b>FI</b>	Finland	<b>LT</b>	Lithuania	<b>SK</b>	Slovakia
<b>AT</b>	Austria	<b>FR</b>	France	<b>LU</b>	Luxembourg	<b>SN</b>	Senegal
<b>AU</b>	Australia	<b>GA</b>	Gabon	<b>LV</b>	Latvia	<b>SZ</b>	Swaziland
<b>AZ</b>	Azerbaijan	<b>GB</b>	United Kingdom	<b>MC</b>	Monaco	<b>TD</b>	Chad
<b>BA</b>	Bosnia and Herzegovina	<b>GE</b>	Georgia	<b>MD</b>	Republic of Moldova	<b>TG</b>	Togo
<b>BB</b>	Barbados	<b>GH</b>	Ghana	<b>MG</b>	Madagascar	<b>TJ</b>	Tajikistan
<b>BE</b>	Belgium	<b>GN</b>	Guinea	<b>MK</b>	The former Yugoslav Republic of Macedonia	<b>TM</b>	Turkmenistan
<b>BF</b>	Burkina Faso	<b>GR</b>	Greece	<b>ML</b>	Mali	<b>TR</b>	Turkey
<b>BG</b>	Bulgaria	<b>HU</b>	Hungary	<b>MN</b>	Mongolia	<b>TT</b>	Trinidad and Tobago
<b>BJ</b>	Benin	<b>IE</b>	Ireland	<b>MR</b>	Mauritania	<b>UA</b>	Ukraine
<b>BR</b>	Brazil	<b>IL</b>	Israel	<b>MW</b>	Malawi	<b>UG</b>	Uganda
<b>BY</b>	Belarus	<b>IS</b>	Iceland	<b>MX</b>	Mexico	<b>US</b>	United States of America
<b>CA</b>	Canada	<b>IT</b>	Italy	<b>NE</b>	Niger	<b>UZ</b>	Uzbekistan
<b>CF</b>	Central African Republic	<b>JP</b>	Japan	<b>NL</b>	Netherlands	<b>VN</b>	Viet Nam
<b>CG</b>	Congo	<b>KE</b>	Kenya	<b>NO</b>	Norway	<b>YU</b>	Yugoslavia
<b>CH</b>	Switzerland	<b>KG</b>	Kyrgyzstan	<b>NZ</b>	New Zealand	<b>ZW</b>	Zimbabwe
<b>CI</b>	Côte d'Ivoire	<b>KP</b>	Democratic People's Republic of Korea	<b>PL</b>	Poland		
<b>CM</b>	Cameroon	<b>KR</b>	Republic of Korea	<b>PT</b>	Portugal		
<b>CN</b>	China	<b>KZ</b>	Kazakstan	<b>RO</b>	Romania		
<b>CU</b>	Cuba	<b>LC</b>	Saint Lucia	<b>RU</b>	Russian Federation		
<b>CZ</b>	Czech Republic	<b>LI</b>	Liechtenstein	<b>SD</b>	Sudan		
<b>DE</b>	Germany	<b>LK</b>	Sri Lanka	<b>SE</b>	Sweden		
<b>DK</b>	Denmark	<b>LR</b>	Liberia	<b>SG</b>	Singapore		
<b>EE</b>	Estonia						

5 APPLICANT: RADIO DESIGN INNOVATION TJ AB  
TITLE OF INVENTION: SEAMLESS LOBE HANDOVER

10

**Field of invention**

The present invention relates to a method in a telecommunication system for communication between mobile stations and at least one base station site in said telecommunication system.

15

**Prior art**

Figure 1 discloses a schematic diagram of a flexible lobe shaping system. The antenna array has preferably eight antenna elements.

Each frequency channel has its own set of weights (e.g.  $W_1(1) - W_8(1)$  in Figure 1). The number of these weights is determined by the number of antenna elements used.

The number of weight sets is determined by the number of simultaneously channels. Each frequency channel has one set of weights and if SDMA (Spatial Division Multiple Access) is used there must be several weight settings for each frequency channel.

25

No. Of weight sets = No. of frequency channels  $\times$  SDMA factor.

No. of complex weights = No. of frequency channels  $\times$  SDMA factor  $\times$  number of antenna elements.

The lobe shaping system of Figure 1 is described in detail in the pending applications 9601613-4 (Method and Arrangement of Converting a Cellular Telecommunication System, Applicant: Radio Design AB), 9601615-9 (Rotating Lobe Access Method, Applicant: Radio Design AB) and 9601614-2 (Antenna System, Applicant: Radio Design AB), which applications are incorporated herein by reference.

35

A problem with this flexible lobe shaping system is that it is very expensive to implement since much equipment is used.

A less hardware-consuming and thus less expensive solution is the fixed lobe-shaping system as can be seen in Figure 2.

The object of this invention is to avoid the changing of channel when hand-over is carried out in for example the above mentioned fixed lobe-shaping system.

40

**CONFIRMATION COPY**

Another object of the invention is to avoid the changing of receiver/transmitter equipment in the base station site.

### **Brief description of the invention**

5 The above object is achieved by means of a method in a telecommunication system for communication between mobile stations and at least one base station site in said telecommunication system, wherein said mobile stations move within said base station site on a channel by use of seamless lobe/sector handover.

Handover without changing transmitter/receiver equipment implies increased  
10 capacity since it results in better trunking efficiency at the base station site.

Other features of the invention are set out in the dependent claims.

### **Brief description of the drawings**

Figure 1 is a flexible lobe-shaping system;

15 Figure 2 is a fixed lobe-shaping system according to the invention;

Figure 3 is a block diagram of the system in Figure 2;

Figure 4 discloses adjacent fixed lobes with three excited antenna panels  
according to the invention;

Figure 5 discloses a base station site with three sectors comprising one lobe  
20 each, and with one antenna per sector;

Figure 6 discloses a base station site according to the invention with three  
sectors comprising five lobes each, and one antenna array per sector;

Figure 7 discloses a base station site according to the invention with three  
sectors comprising five lobes each, and one antenna array for all sectors;

25 Figure 8 discloses a base station site according to the invention with one  
sector comprising fifteen lobes and one antenna array for said sector;

Figures 9-12 disclose different structures of the lobe shaping system  
according to the invention.

### **30 Detailed description of an embodiment of the invention**

The invention preferably refers to handover between lobes without changing channel. This implies that the mobile terminal can move within a site on the same channel by use of seamless lobe handover. The handover is seamless in the meaning that it can not be noted by the mobile user.

35 The invention will now be described with reference to Figures 3-12.

Figure 2 discloses an implementation of the block diagram in Figure 3. TRX in Figure 2 corresponds to transmitter and receiver equipment in Figures 3, 9-12. LF1 – LF<sub>n</sub> and the antennas in Figure 2 correspond to the Antenna array related equipment and the antenna array in Figures 3, 10, 12, respectively.

40 The cellular mobile radio system of the invention includes several base

station sites and mobile stations (terminals). Each base station site has one or more sectors divided into a number of fixed lobes (Figures 4-8). The base station site comprises base stations with base station transmitter equipment and a base station receiver equipment. The mobile station comprises a mobile station receiver and a mobile station transmitter. The communication in the cellular mobile radio system between a base station site and a mobile station is achieved by the following steps. As mentioned above each base station site uses a number of fixed lobes (Figures 4-8) in accordance with Figures 2, 3, 9-12. A connection is established between the base station site transmitter/receiver equipment and a mobile station. One of the lobes in one of the sectors of the base station site is used for transmission of signals between base station site transmitter/receiver and mobile station transmitter/receiver. The base station site continuously measures the signals received from the mobile station. For example the base station site determines the best lobe by comparing the signal received in actual lobe with signal received in alternative lobes. This can be carried out by comparing received signal strength or by comparing received signal to interference ratio in each lobe.

This comparison between signal strengths etc. in the lobes may imply a handover between the lobes. When the handover is performed the base station site changes utilized lobe of the base station site to another lobe of the same base station site without changing the serving transmitter and receiver equipment, i.e. the base station site uses the same transmitter/receiver equipment for the new lobe.

In another embodiment of the invention the base station site also changes transmitter/receiver equipment when changing lobe.

Thus, the channel is not changed when changing lobe. It should be realized that with channel we mean frequency, time slot, CDMA-coding etc. It should also be realized that instead of effecting handover between lobes as mentioned above, handover between sectors can also be achieved in the same manner.

A number of different handover situations will now be described with reference particularly to Figures 5-12. First the concept "base station site" will be explained with reference to Figure 6. The concept "base station site" in Figure 6 is defined as the covering area of the three sectors, and the base station site includes the three antenna arrays which normally are controlled by three base stations, i.e. one base station for each antenna array.

As mentioned above handover (HO) can be performed between different lobes and different sectors in a base station site. As disclosed in Figure 5 a base station site can consist of three different physical antennas, each connected to a base station, wherein handover can be performed between these antennas (base stations). This is the case in Figures 5, 11 in which lobe/sector handover is performed changing from sector 1 to sector 2. The transmitter/receiver equipment (TRX) controlling sector 1 is changed during handover to another transmitter/re-

ceiver equipment for sector 2. However, the same channel is used.

Another possibility is described in Figures 5, 9. In this case lobe/sector handover is performed changing from sector 1 to sector 2 but the same transmitter/receiver equipment of the base station site is used. The same channel or  
5 another channel can be used.

In Figures 3 and 6, lobe handover within a sector is performed without changing transmitter/receiver equipment. Same or changed channel can be used.

In Figures 6 and 12 sector/lobe handover is performed changing from one sector and corresponding TRX1 to another sector and corresponding TRX2. Same  
10 or changed channel can be used.

In Figures 3 and 7 lobe handover between lobes 4 and 5 is either performed within a sector or a lobe/sector handover is performed between sectors 6 and 7, wherein handover is performed from lobe 8 in sector 6 to lobe 9 in sector 7. In this case the same TRX equipment is used and the same or changed channel can be  
15 used.

In Figures 6, 10 lobe/sector handover is performed changing from one sector to another sector but the same transmitter/receiver equipment of the base station site is used.

The above is only to be considered as a preferable embodiment, and the scope  
20 of the invention is only limited by the following claims.



## CLAIMS

1. A method in a telecommunication system for communication between mobile stations and at least one base station site in said telecommunication system, **characterized** in that said mobile stations move within said at least one base station site on a channel by use of seamless lobe handover.
2. A method as claimed in claim 1, **characterized** in that said telecommunication system includes said at least one base station site having one or more sectors each divided into a number of fixed lobes comprising the steps of:
- establishing a connection between a base station site transmitter/receiver equipment in said at least one base station site and a mobile station;
  - transmitting signals from said base station site transmitter equipment to said mobile station receiver and transmitting signals from said mobile station transmitter to said base station site receiver equipment by utilizing one of said lobes in one of the sectors of said base station;
  - changing said utilized lobe of said at least one base station site to another lobe of said at least one base station site without changing transmitter/receiver equipment of said base station site.
3. A method as claimed in claim 1, **characterized** in that said telecommunication system includes said at least one base station site having one or more sectors each divided into a number of fixed lobes comprising the steps of:
- establishing a connection between a base station site transmitter/receiver equipment in said at least one base station site and a mobile station;
  - transmitting signals from said base station site transmitter equipment to said mobile station receiver and transmitting signals from said mobile station transmitter to said base station site receiver equipment by utilizing one of said lobes in one of the sectors of said base station;
  - changing said utilized lobe and corresponding transmitter/receiver equipment (TRX1) of said at least one base station site to another lobe and corresponding transmitter/receiver equipment (TRX2) of said base station site.
4. A method as claimed in any of the preceding claims, **characterized** in that an antenna array and its supporting equipment is used to form fixed lobes.
5. A method as claimed in any of the preceding claims, **characterized** in that the channel is not changed when changing lobe.
6. A method as claimed in claim 5, **characterized** in that the change of the lobe is made without any signalling or channel order to and from said base station site to control the change of the lobe.
7. A method as claimed in any of claims 1-4, **characterized** in that said channel is changed when changing lobe.
8. A method as claimed in any of the preceding claims, **characterized** in that equipment in said base station site determines the best lobe by comparing signals

received in actual lobe with signals received in adjacent lobes.

9. A method as claimed in claim 8, **characterized** in that signals are compared by detecting received signal strength.

10. A method as claimed in claim 8, **characterized** in that signals are compared by evaluating received signal to interference ratio.

11. A method in a telecommunication system for communication between mobile stations and at least one base station site in said telecommunication system, **characterized** in that said mobile stations move within said at least one base station site on a channel by use of seamless sector handover.

12. A method as claimed in claim 11, **characterized** in that said telecommunication system includes said at least one base station site having a plurality of sectors comprising the steps of:

- establishing a connection between a base station site transmitter/receiver equipment in said at least one base station site and a mobile station;

- transmitting signals from said base station site transmitter to said mobile station receiver and transmitting signals from said mobile station transmitter to said base station site receiver equipment by utilizing one of the sectors in said base station site;

- changing utilized sector in said base station site to another sector in said base station site without changing transmitter/receiver equipment of said base station site.

13. A method as claimed in claim 11, **characterized** in that said telecommunication system includes said at least one base station site having a plurality of sectors comprising the steps of:

- establishing a connection between a base station site transmitter/receiver equipment and a mobile station;

- transmitting signals from said base station site transmitter to said mobile station receiver and transmitting signals from said mobile station transmitter to said base station site receiver equipment by utilizing one of the sectors in said base station site;

- changing utilized sector and corresponding transmitter/receiver equipment (TRX1) of said at least one base station site to another sector and corresponding transmitter/receiver equipment (TRX2) of said at least one base station site.

14. A method as claimed in any of claims 11-13, **characterized** in that said channel is not changed when changing sector.

15. A method as claimed in any of claims 11-14, **characterized** in that said change of sector is made without any signalling or channel order to and from said base station site to control said change of sector.

16. A method as claimed in any of claims 11-13, **characterized** in that said channel is changed when changing sector.

17. A method as claimed in any of claims 11-16, **characterized** in that equipment in said base station site determines the best sector by comparing signals received in actual sector with signals received in adjacent sectors.

18. A method as claimed in claim 17, **characterized** in that said signals are  
5 compared by detecting received signal strength.

19. A method as claimed in claim 17, **characterized** in that said signals are compared by evaluating received signal to interference ratio.

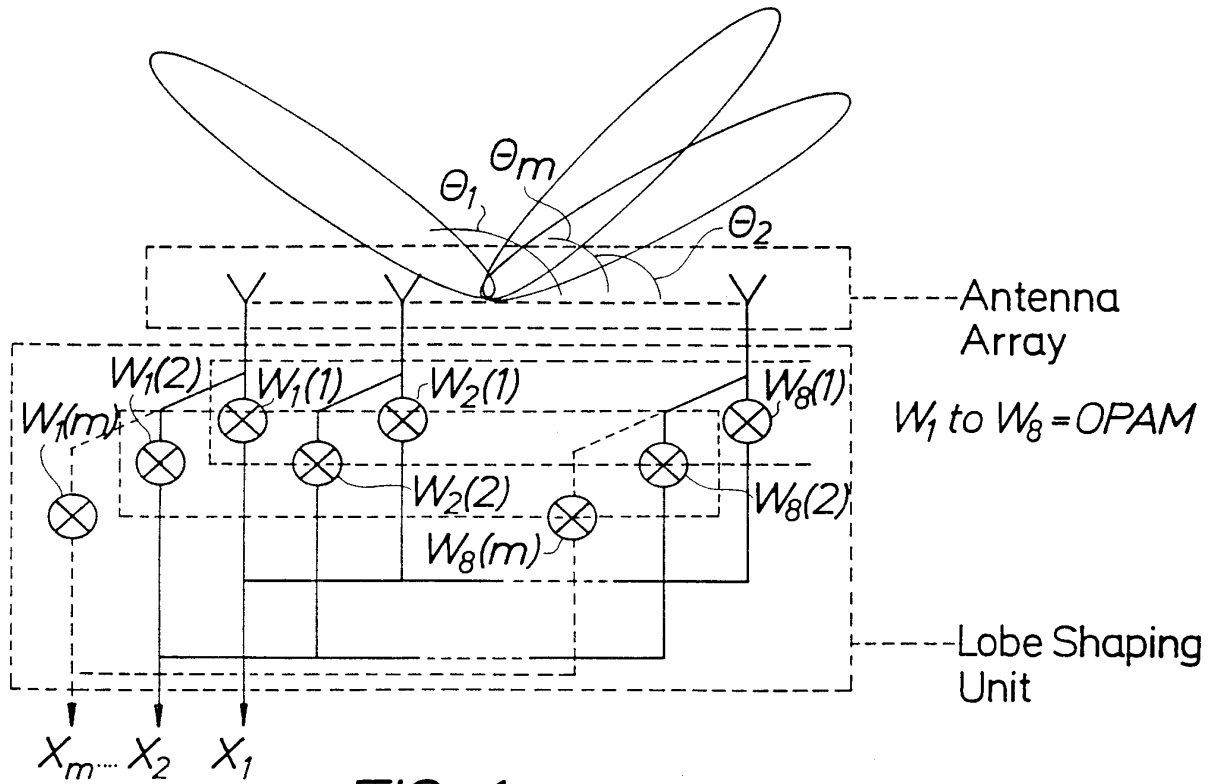


FIG. 1

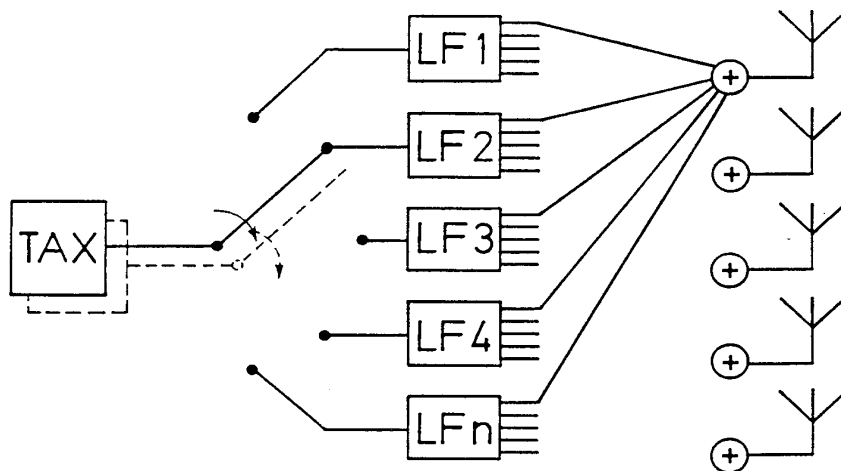


FIG. 2

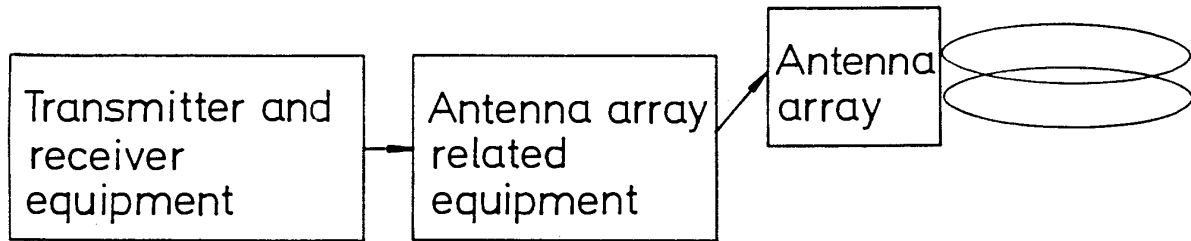


FIG. 3

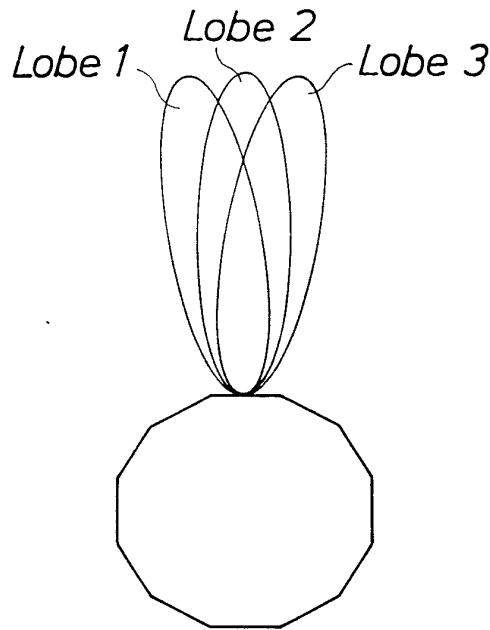


FIG. 4

SUBSTITUTE SHEET (RULE 26)

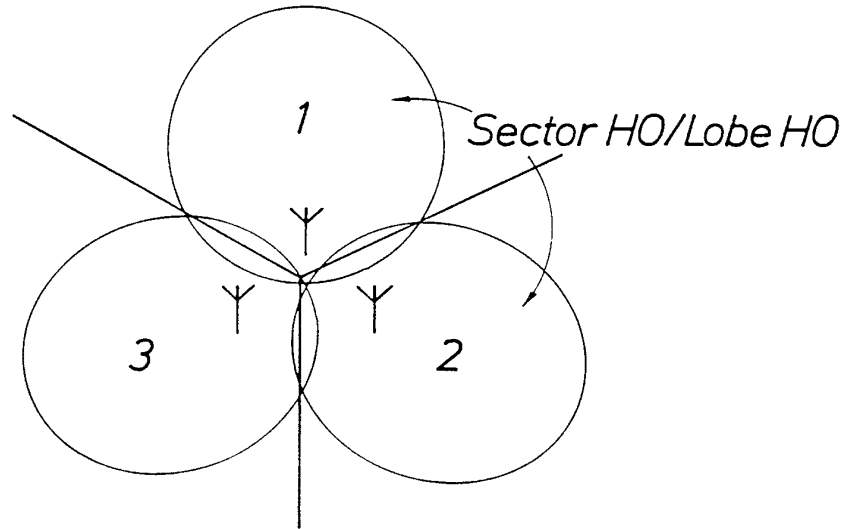


FIG. 5

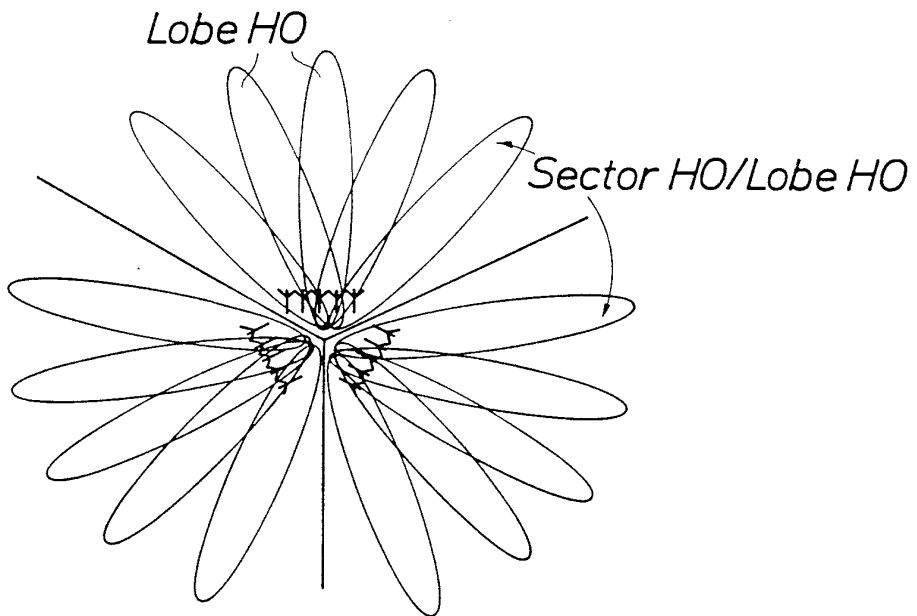


FIG. 6

SUBSTITUTE SHEET (RULE 26)

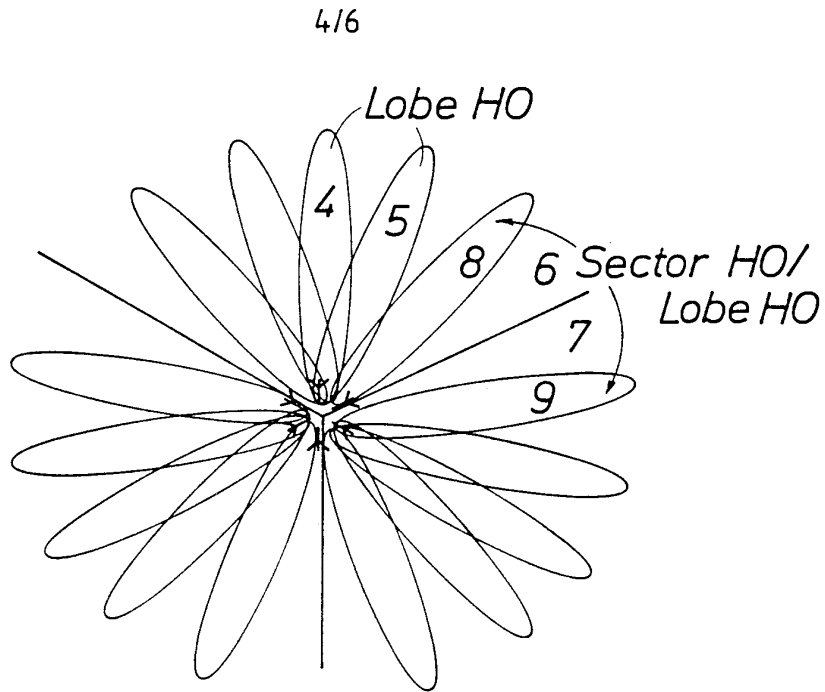


FIG. 7

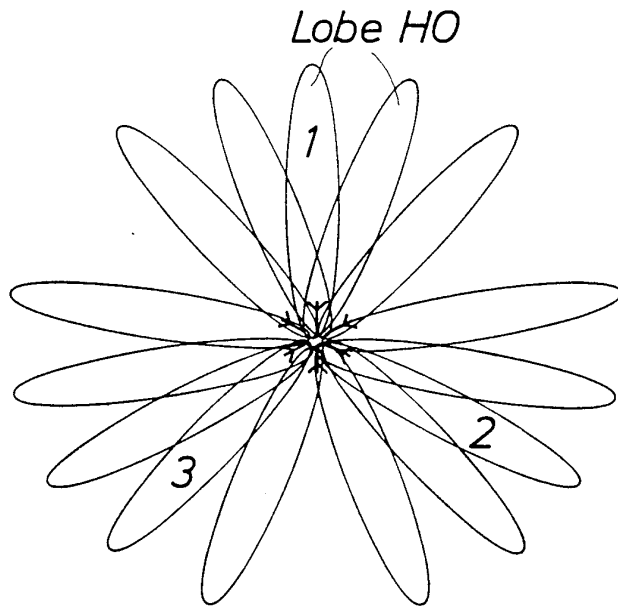


FIG. 8

SUBSTITUTE SHEET (RULE 26)

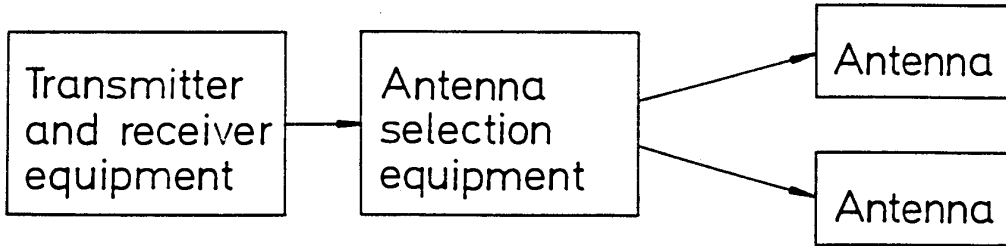


FIG. 9

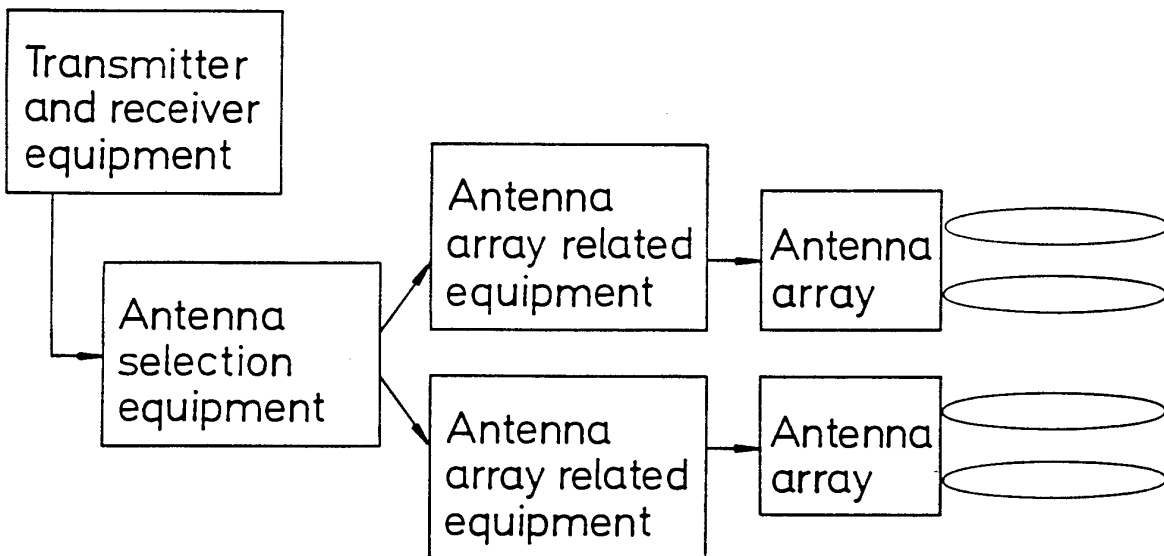


FIG. 10



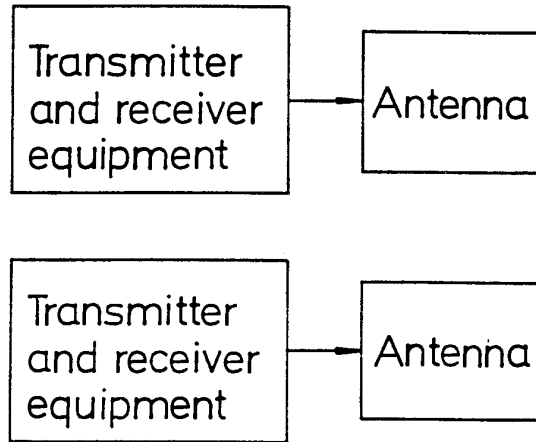


FIG. 11

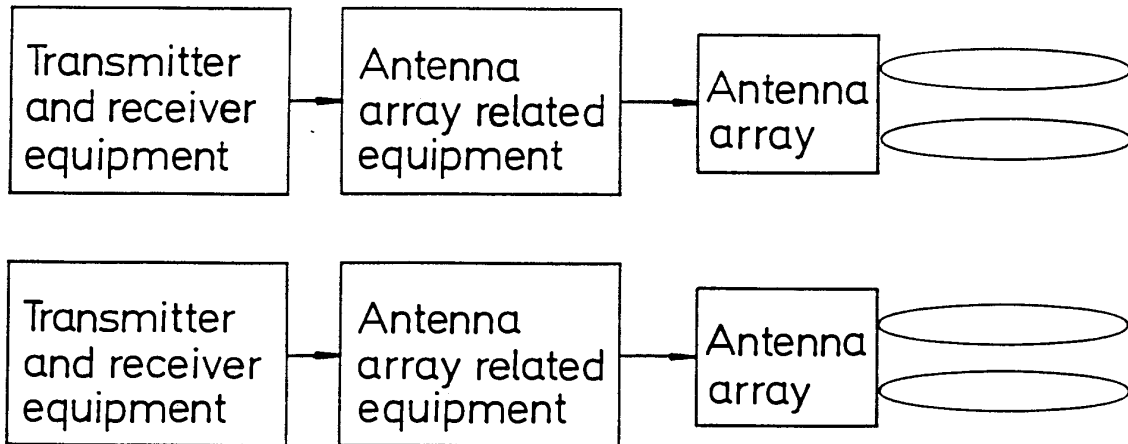


FIG. 12

## Electronic Patent Application Fee Transmittal

<b>Application Number:</b>				
<b>Filing Date:</b>				
<b>Title of Invention:</b>	DIRECTED WIRELESS COMMUNICATION			
<b>First Named Inventor/Applicant Name:</b>	Marcus Da Silva			
<b>Filer:</b>	Nicholas R. Transier/Jenny Stedman			
<b>Attorney Docket Number:</b>	E1027.800(T).US1D1C1C3			
Filed as Small Entity				
<b>Filing Fees for Track I Prioritized Examination - Nonprovisional Application under 35 USC 111(a)</b>				
Description	Fee Code	Quantity	Amount	Sub-Total in USD(\$)
<b>Basic Filing:</b>				
UTILITY FILING FEE (ELECTRONIC FILING)	4011	1	70	70
UTILITY SEARCH FEE	2111	1	300	300
UTILITY EXAMINATION FEE	2311	1	360	360
REQUEST FOR PRIORITIZED EXAMINATION	2817	1	2000	2000
<b>Pages:</b>				
<b>Claims:</b>				
<b>Miscellaneous-Filing:</b>				

Description	Fee Code	Quantity	Amount	Sub-Total in USD(\$)
PUBL. FEE- EARLY, VOLUNTARY, OR NORMAL	1504	1	0	0
PROCESSING FEE, EXCEPT PROV. APPLS.	2830	1	70	70
<b>Petition:</b>				
<b>Patent-Appeals-and-Interference:</b>				
<b>Post-Allowance-and-Post-Issuance:</b>				
<b>Extension-of-Time:</b>				
<b>Miscellaneous:</b>				
<b>Total in USD (\$)</b>				<b>2800</b>

## Electronic Acknowledgement Receipt

<b>EFS ID:</b>	29011435
<b>Application Number:</b>	15495539
<b>International Application Number:</b>	
<b>Confirmation Number:</b>	1050
<b>Title of Invention:</b>	DIRECTED WIRELESS COMMUNICATION
<b>First Named Inventor/Applicant Name:</b>	Marcus Da Silva
<b>Customer Number:</b>	114581
<b>Filer:</b>	Nicholas R. Transier/Jenny Stedman
<b>Filer Authorized By:</b>	Nicholas R. Transier
<b>Attorney Docket Number:</b>	E1027.800(T).US1D1C1C3
<b>Receipt Date:</b>	24-APR-2017
<b>Filing Date:</b>	
<b>Time Stamp:</b>	17:34:34
<b>Application Type:</b>	Utility under 35 USC 111(a)

### Payment information:

Submitted with Payment	yes
Payment Type	CARD
Payment was successfully received in RAM	\$2800
RAM confirmation Number	042517INTEFSW17351000
Deposit Account	
Authorized User	

The Director of the USPTO is hereby authorized to charge indicated fees and credit any overpayment as follows:

<b>File Listing:</b>					
<b>Document Number</b>	<b>Document Description</b>	<b>File Name</b>	<b>File Size(Bytes)/ Message Digest</b>	<b>Multi Part /.zip</b>	<b>Pages (if appl.)</b>
1	Application Data Sheet	WebADS.pdf	233723	no	11
			1bf03203367bc63a5c51d179deab14a7679bf7a		
<b>Warnings:</b>					
<b>Information:</b>					
2	TrackOne Request	2017-04-24_Track_One_Request-C3.pdf	114188	no	2
			a1d31a65ec4906f6f215f60d99758b57af037d4e		
<b>Warnings:</b>					
<b>Information:</b>					
3	Oath or Declaration filed	Declarations.pdf	1030157	no	17
			d4d2e2e410ee65ab5d46d28cc71da1e06b4984ff		
<b>Warnings:</b>					
<b>Information:</b>					
4	Power of Attorney	2017-04-24_POA-C3.pdf	761429	no	2
			b0d3b04f3ce2e378d8cd8503b3a12de1ff61038b		
<b>Warnings:</b>					
<b>Information:</b>					
5		2017-04-24_Specification-C3.pdf	386110	yes	50
			95253e46bdf4d6b8e6ae3caa5ae561fa210db59c		
	<b>Multipart Description/PDF files in .zip description</b>				
		<b>Document Description</b>	<b>Start</b>	<b>End</b>	
		Specification	1	44	
		Claims	45	49	
		Abstract	50	50	

<b>Warnings:</b>					
<b>Information:</b>					
6	Drawings-only black and white line drawings	2017-04-24_Figures-C3.pdf	2451085 863be9d3035aa188765ed573bc128d87d8b3a299	no	18
<b>Warnings:</b>					
<b>Information:</b>					
7	Transmittal Letter	2017-04-24_IDS_Transmittal-C3.pdf	16865 30247b20e7a3d082f680a3769e5776a57a1824b5	no	2
<b>Warnings:</b>					
<b>Information:</b>					
8	Information Disclosure Statement (IDS) Form (SB08)	2017-04-24_IDS-C3.pdf	1037540 1c8566ba914cd8cb09b877e693e1f86f2801a5d	no	7
<b>Warnings:</b>					
<b>Information:</b>					
9	Non Patent Literature	Anastasi.pdf	2727329 74ec4368eb7923f56b5b1382e3cf6ea009692ba	no	12
<b>Warnings:</b>					
<b>Information:</b>					
10	Non Patent Literature	CDNA18957ENC_001.pdf	9980272 05ae8b480f93cf245c50b90e62a4068abc55d41c	no	516
<b>Warnings:</b>					
<b>Information:</b>					
11	Non Patent Literature	gans.pdf	1175070 9d2e9168ff2c9d858f3b02620197e6c2a27ef5b	no	7
<b>Warnings:</b>					
<b>Information:</b>					
12	Non Patent Literature	German_et_al.pdf	3338193 9772a2d3bb97735c846000537631b26c3e0d9030	no	4
<b>Warnings:</b>					
<b>Information:</b>					

13	Non Patent Literature	Gucsalla.pdf	10263985	no	25
			6f3fd751d8dec41f5f77b3a94a24131abe73e2		
<b>Warnings:</b>					
<b>Information:</b>					
14	Non Patent Literature	hashemi_indoor.pdf	2636715	no	26
			8e3455cdd8f39be2081cf81fe98aa028bcefe502		
<b>Warnings:</b>					
<b>Information:</b>					
15	Non Patent Literature	kivinen.pdf	10957942	no	13
			419be9d5f90c570011cfa95049209c61383261fc		
<b>Warnings:</b>					
<b>Information:</b>					
16	Non Patent Literature	leland.pdf	3243962	no	15
			79a47a567e0957f9189dc1552f7389a00c46ae52		
<b>Warnings:</b>					
<b>Information:</b>					
17	Non Patent Literature	medbo_pathloss.pdf	491294	no	7
			4f0a9fca125ef0111f9de799075782b4217d6943		
<b>Warnings:</b>					
<b>Information:</b>					
18	Foreign Reference	WO1999021391A2.pdf	358774	no	15
			ee34181f8fcb75b59ae9e43dc8e6d85a29d0b4e6		
<b>Warnings:</b>					
<b>Information:</b>					
19	Fee Worksheet (SB06)	fee-info.pdf	40284	no	2
			e9ad93446f7c551d0b56f7a45f6cb58a571ca3d0		
<b>Warnings:</b>					
<b>Information:</b>					
<b>Total Files Size (in bytes):</b>			51244917		

**This Acknowledgement Receipt evidences receipt on the noted date by the USPTO of the indicated documents, characterized by the applicant, and including page counts, where applicable. It serves as evidence of receipt similar to a Post Card, as described in MPEP 503.**

**New Applications Under 35 U.S.C. 111**

**If a new application is being filed and the application includes the necessary components for a filing date (see 37 CFR 1.53(b)-(d) and MPEP 506), a Filing Receipt (37 CFR 1.54) will be issued in due course and the date shown on this Acknowledgement Receipt will establish the filing date of the application.**

**National Stage of an International Application under 35 U.S.C. 371**

**If a timely submission to enter the national stage of an international application is compliant with the conditions of 35 U.S.C. 371 and other applicable requirements a Form PCT/DO/EO/903 indicating acceptance of the application as a national stage submission under 35 U.S.C. 371 will be issued in addition to the Filing Receipt, in due course.**

**New International Application Filed with the USPTO as a Receiving Office**

**If a new international application is being filed and the international application includes the necessary components for an international filing date (see PCT Article 11 and MPEP 1810), a Notification of the International Application Number and of the International Filing Date (Form PCT/RO/105) will be issued in due course, subject to prescriptions concerning national security, and the date shown on this Acknowledgement Receipt will establish the international filing date of the application.**



<b>Application Data Sheet 37 CFR 1.76</b>		Attorney Docket Number	E1027.800(T).US1D1C1C3
		Application Number	
Title of Invention	DIRECTED WIRELESS COMMUNICATION		
<p>The application data sheet is part of the provisional or nonprovisional application for which it is being submitted. The following form contains the bibliographic data arranged in a format specified by the United States Patent and Trademark Office as outlined in 37 CFR 1.76. This document may be completed electronically and submitted to the Office in electronic format using the Electronic Filing System (EFS) or the document may be printed and included in a paper filed application.</p>			

**Secrecy Order 37 CFR 5.2:**

Portions or all of the application associated with this Application Data Sheet may fall under a Secrecy Order pursuant to 37 CFR 5.2 (Paper filers only. Applications that fall under Secrecy Order may not be filed electronically.)

**Inventor Information:**

Inventor 1					
Legal Name					
Prefix	Given Name	Middle Name	Family Name	Suffix	
	Marcus		Da Silva		
<b>Residence Information (Select One)</b> <input checked="" type="radio"/> US Residency <input type="radio"/> Non US Residency <input type="radio"/> Active US Military Service					
<b>City</b>	Spokane	<b>State/Province</b>	WA	<b>Country of Residence</b> <sup>i</sup>	US
<b>Mailing Address of Inventor:</b>					
<b>Address 1</b>	5510 East 25th				
<b>Address 2</b>					
<b>City</b>	Spokane	<b>State/Province</b>	WA		
<b>Postal Code</b>	99223	<b>Country</b> <sup>i</sup>	US		
Inventor 2					
Legal Name					
Prefix	Given Name	Middle Name	Family Name	Suffix	
	William	J.	Crilly		
<b>Residence Information (Select One)</b> <input checked="" type="radio"/> US Residency <input type="radio"/> Non US Residency <input type="radio"/> Active US Military Service					
<b>City</b>	Liberty Lake	<b>State/Province</b>	WA	<b>Country of Residence</b> <sup>i</sup>	US
<b>Mailing Address of Inventor:</b>					
<b>Address 1</b>	23825 E. 2nd Avenue Ct.				
<b>Address 2</b>					
<b>City</b>	Liberty Lake	<b>State/Province</b>	WA		
<b>Postal Code</b>	99019	<b>Country</b> <sup>i</sup>	US		
Inventor 3					
Legal Name					
Prefix	Given Name	Middle Name	Family Name	Suffix	
	James		Brennan		

Under the Paperwork Reduction Act of 1995, no persons are required to respond to a collection of information unless it contains a valid OMB control number.

<b>Application Data Sheet 37 CFR 1.76</b>		Attorney Docket Number	E1027.800(T).US1D1C1C3		
		Application Number			
Title of Invention	DIRECTED WIRELESS COMMUNICATION				
<b>Residence Information (Select One)</b> <input checked="" type="radio"/> US Residency <input type="radio"/> Non US Residency <input type="radio"/> Active US Military Service					
City	Sammamish	State/Province	WA	Country of Residence <sup>i</sup>	US
<b>Mailing Address of Inventor:</b>					
Address 1	414 213th PL SE				
Address 2					
City	Sammamish	State/Province	WA		
Postal Code	98074	Country <sup>i</sup>	US		
<b>Inventor 4</b>					
<b>Legal Name</b>					
Prefix	Given Name	Middle Name	Family Name	Suffix	
	Robert	J.	Conley		
<b>Residence Information (Select One)</b> <input checked="" type="radio"/> US Residency <input type="radio"/> Non US Residency <input type="radio"/> Active US Military Service					
City	Liberty Lake	State/Province	WA	Country of Residence <sup>i</sup>	US
<b>Mailing Address of Inventor:</b>					
Address 1	23326 E. 2nd Avenue				
Address 2					
City	Liberty Lake	State/Province	WA		
Postal Code	99019	Country <sup>i</sup>	US		
<b>Inventor 5</b>					
<b>Legal Name</b>					
Prefix	Given Name	Middle Name	Family Name	Suffix	
	Siavash		Alamouti		
<b>Residence Information (Select One)</b> <input checked="" type="radio"/> US Residency <input type="radio"/> Non US Residency <input type="radio"/> Active US Military Service					
City	Spokane	State/Province	WA	Country of Residence <sup>i</sup>	US
<b>Mailing Address of Inventor:</b>					
Address 1	2123 West 1st Ave., Apt 3				
Address 2					
City	Spokane	State/Province	WA		
Postal Code	99204	Country <sup>i</sup>	US		
<b>Inventor 6</b>					
<b>Legal Name</b>					
Prefix	Given Name	Middle Name	Family Name	Suffix	
	Eduardo		Casas		

<b>Application Data Sheet 37 CFR 1.76</b>		Attorney Docket Number	E1027.800(T).US1D1C1C3		
		Application Number			
Title of Invention	DIRECTED WIRELESS COMMUNICATION				
<b>Residence Information (Select One)</b> <input type="radio"/> US Residency <input checked="" type="radio"/> Non US Residency <input type="radio"/> Active US Military Service					
City	Vancouver	Country of Residence <sup>i</sup>	CA		
<b>Mailing Address of Inventor:</b>					
Address 1	7542 Ontario Street				
Address 2					
City	Vancouver	State/Province			
Postal Code	V5X3C2	Country <sup>i</sup>	CA		
<b>Inventor 7</b>					
<b>Legal Name</b>					
Prefix	Given Name	Middle Name	Family Name	Suffix	
	Hujun		Yin		
<b>Residence Information (Select One)</b> <input checked="" type="radio"/> US Residency <input type="radio"/> Non US Residency <input type="radio"/> Active US Military Service					
City	Spokane	State/Province	WA	Country of Residence <sup>i</sup>	US
<b>Mailing Address of Inventor:</b>					
Address 1	2415 N. Cherry Street, Apt. 23				
Address 2					
City	Spokane	State/Province	WA		
Postal Code	99216	Country <sup>i</sup>	US		
<b>Inventor 8</b>					
<b>Legal Name</b>					
Prefix	Given Name	Middle Name	Family Name	Suffix	
	Bobby		Jose		
<b>Residence Information (Select One)</b> <input checked="" type="radio"/> US Residency <input type="radio"/> Non US Residency <input type="radio"/> Active US Military Service					
City	Veradale	State/Province	WA	Country of Residence <sup>i</sup>	US
<b>Mailing Address of Inventor:</b>					
Address 1	15821 East 4th Ave., Apt F 125				
Address 2					
City	Veradale	State/Province	WA		
Postal Code	99037	Country <sup>i</sup>	US		
<b>Inventor 9</b>					
<b>Legal Name</b>					

Under the Paperwork Reduction Act of 1995, no persons are required to respond to a collection of information unless it contains a valid OMB control number.

<b>Application Data Sheet 37 CFR 1.76</b>	Attorney Docket Number	E1027.800(T).US1D1C1C3
	Application Number	
Title of Invention	DIRECTED WIRELESS COMMUNICATION	

<b>Prefix</b>	<b>Given Name</b>	<b>Middle Name</b>	<b>Family Name</b>	<b>Suffix</b>
	Yang-Seok		Choi	
<b>Residence Information (Select One)</b> <input checked="" type="radio"/> US Residency <input type="radio"/> Non US Residency <input type="radio"/> Active US Military Service				
<b>City</b>	Liberty Lake	<b>State/Province</b>	WA	<b>Country of Residence</b> <sup>i</sup>
				US

**Mailing Address of Inventor:**

<b>Address 1</b>	22809 East Country Vista Drive, Apt 438			
<b>Address 2</b>				
<b>City</b>	Liberty Lake	<b>State/Province</b>	WA	
<b>Postal Code</b>	99019	<b>Country</b> <sup>i</sup>	US	

**Inventor 10****Legal Name**

<b>Prefix</b>	<b>Given Name</b>	<b>Middle Name</b>	<b>Family Name</b>	<b>Suffix</b>
	Vahid		Tarokh	
<b>Residence Information (Select One)</b> <input checked="" type="radio"/> US Residency <input type="radio"/> Non US Residency <input type="radio"/> Active US Military Service				
<b>City</b>	Cambridge	<b>State/Province</b>	MA	<b>Country of Residence</b> <sup>i</sup>
				US

**Mailing Address of Inventor:**

<b>Address 1</b>	157 Pleasant Street, Apt 305			
<b>Address 2</b>				
<b>City</b>	Cambridge	<b>State/Province</b>	MA	
<b>Postal Code</b>	02139	<b>Country</b> <sup>i</sup>	US	

**Inventor 11****Legal Name**

<b>Prefix</b>	<b>Given Name</b>	<b>Middle Name</b>	<b>Family Name</b>	<b>Suffix</b>
	Praveen		Mehrotra	
<b>Residence Information (Select One)</b> <input checked="" type="radio"/> US Residency <input type="radio"/> Non US Residency <input type="radio"/> Active US Military Service				
<b>City</b>	Spokane	<b>State/Province</b>	WA	<b>Country of Residence</b> <sup>i</sup>
				US

**Mailing Address of Inventor:**

<b>Address 1</b>	13303 East Mission Ave., Apt 75			
<b>Address 2</b>				
<b>City</b>	Spokane	<b>State/Province</b>	WA	
<b>Postal Code</b>	99216	<b>Country</b> <sup>i</sup>	US	

All Inventors Must Be Listed - Additional Inventor Information blocks may be generated within this form by selecting the **Add** button.

Add
-----

<b>Application Data Sheet 37 CFR 1.76</b>		Attorney Docket Number	E1027.800(T).US1D1C1C3
		Application Number	
Title of Invention	DIRECTED WIRELESS COMMUNICATION		

**Correspondence Information:**

Enter either Customer Number or complete the Correspondence Information section below.  
For further information see 37 CFR 1.33(a).

An Address is being provided for the correspondence information of this application.

Customer Number	114581		
Email Address	sandiego@eip.com	<input type="button" value="Add Email"/>	<input type="button" value="Remove Email"/>

**Application Information:**

Title of the Invention	DIRECTED WIRELESS COMMUNICATION		
Attorney Docket Number	E1027.800(T).US1D1C1C3	Small Entity Status Claimed	<input checked="" type="checkbox"/>
Application Type	Nonprovisional		
Subject Matter	Utility		
Total Number of Drawing Sheets (if any)	18	Suggested Figure for Publication (if any)	

**Filing By Reference:**

Only complete this section when filing an application by reference under 35 U.S.C. 111(c) and 37 CFR 1.57(a). Do not complete this section if application papers including a specification and any drawings are being filed. Any domestic benefit or foreign priority information must be provided in the appropriate section(s) below (i.e., "Domestic Benefit/National Stage Information" and "Foreign Priority Information").

For the purposes of a filing date under 37 CFR 1.53(b), the description and any drawings of the present application are replaced by this reference to the previously filed application, subject to conditions and requirements of 37 CFR 1.57(a).

Application number of the previously filed application	Filing date (YYYY-MM-DD)	Intellectual Property Authority or Country

**Publication Information:**

Request Early Publication (Fee required at time of Request 37 CFR 1.219)

**Request Not to Publish.** I hereby request that the attached application not be published under 35 U.S.C. 122(b) and certify that the invention disclosed in the attached application **has not and will not** be the subject of an application filed in another country, or under a multilateral international agreement, that requires publication at eighteen months after filing.

**Representative Information:**

Representative information should be provided for all practitioners having a power of attorney in the application. Providing this information in the Application Data Sheet does not constitute a power of attorney in the application (see 37 CFR 1.32). Either enter Customer Number or complete the Representative Name section below. If both sections are completed the customer Number will be used for the Representative Information during processing.

Under the Paperwork Reduction Act of 1995, no persons are required to respond to a collection of information unless it contains a valid OMB control number.

<b>Application Data Sheet 37 CFR 1.76</b>		Attorney Docket Number	E1027.800(T).US1D1C1C3		
		Application Number			
Title of Invention	DIRECTED WIRELESS COMMUNICATION				
Please Select One:					
<input checked="" type="radio"/> Customer Number		<input type="radio"/> US Patent Practitioner		<input type="radio"/> Limited Recognition (37 CFR 11.9)	
Customer Number	114581				
Prefix	Given Name	Middle Name	Family Name	Suffix	<input type="button" value="Remove"/>
Registration Number					
Prefix	Given Name	Middle Name	Family Name	Suffix	<input type="button" value="Remove"/>
Registration Number					
Additional Representative Information blocks may be generated within this form by selecting the <b>Add</b> button.					

**Domestic Benefit/National Stage Information:**

This section allows for the applicant to either claim benefit under 35 U.S.C. 119(e), 120, 121, 365(c), or 386(c) or indicate National Stage entry from a PCT application. Providing this information in the application data sheet constitutes the specific reference required by 35 U.S.C. 119(e) or 120, and 37 CFR 1.78.

When referring to the current application, please leave the application number blank.

Prior Application Status		Pending		<input type="button" value="Remove"/>	
Application Number	Continuity Type	Prior Application Number	Filing or 371(c) Date (YYYY-MM-DD)		
	Continuation of	15260147	2016-09-08		
Prior Application Status		Patented		<input type="button" value="Remove"/>	
Application Number	Continuity Type	Prior Application Number	Filing Date (YYYY-MM-DD)	Patent Number	Issue Date (YYYY-MM-DD)
15260147	Continuation of	13855410	2013-04-02	9462589	2016-10-04
Prior Application Status		Patented		<input type="button" value="Remove"/>	
Application Number	Continuity Type	Prior Application Number	Filing Date (YYYY-MM-DD)	Patent Number	Issue Date (YYYY-MM-DD)
13855410	Division of	10700329	2003-11-03	8412106	2013-04-02
Prior Application Status		Expired		<input type="button" value="Remove"/>	
Application Number	Continuity Type	Prior Application Number	Filing or 371(c) Date (YYYY-MM-DD)		
10700329	Claims benefit of provisional	60423660	2002-11-04		
Additional Domestic Benefit/National Stage Data may be generated within this form by selecting the <b>Add</b> button.					

Under the Paperwork Reduction Act of 1995, no persons are required to respond to a collection of information unless it contains a valid OMB control number.

<b>Application Data Sheet 37 CFR 1.76</b>		Attorney Docket Number	E1027.800(T).US1D1C1C3
		Application Number	
Title of Invention	DIRECTED WIRELESS COMMUNICATION		

### Foreign Priority Information:

This section allows for the applicant to claim priority to a foreign application. Providing this information in the application data sheet constitutes the claim for priority as required by 35 U.S.C. 119(b) and 37 CFR 1.55. When priority is claimed to a foreign application that is eligible for retrieval under the priority document exchange program (PDX) the information will be used by the Office to automatically attempt retrieval pursuant to 37 CFR 1.55(i)(1) and (2). Under the PDX program, applicant bears the ultimate responsibility for ensuring that a copy of the foreign application is received by the Office from the participating foreign intellectual property office, or a certified copy of the foreign priority application is filed, within the time period specified in 37 CFR 1.55(g)(1).

Application Number	Country <sup>i</sup>	Filing Date (YYYY-MM-DD)	Access Code <sup>i</sup> (if applicable)

Additional Foreign Priority Data may be generated within this form by selecting the **Add** button.

### Statement under 37 CFR 1.55 or 1.78 for AIA (First Inventor to File) Transition Applications

- This application (1) claims priority to or the benefit of an application filed before March 16, 2013 and (2) also contains, or contained at any time, a claim to a claimed invention that has an effective filing date on or after March 16, 2013.
- NOTE: By providing this statement under 37 CFR 1.55 or 1.78, this application, with a filing date on or after March 16, 2013, will be examined under the first inventor to file provisions of the AIA.

<b>Application Data Sheet 37 CFR 1.76</b>		Attorney Docket Number	E1027.800(T).US1D1C1C3
		Application Number	
Title of Invention	DIRECTED WIRELESS COMMUNICATION		

## Authorization or Opt-Out of Authorization to Permit Access:

When this Application Data Sheet is properly signed and filed with the application, applicant has provided written authority to permit a participating foreign intellectual property (IP) office access to the instant application-as-filed (see paragraph A in subsection 1 below) and the European Patent Office (EPO) access to any search results from the instant application (see paragraph B in subsection 1 below).

Should applicant choose not to provide an authorization identified in subsection 1 below, applicant **must opt-out** of the authorization by checking the corresponding box A or B or both in subsection 2 below.

**NOTE:** This section of the Application Data Sheet is **ONLY** reviewed and processed with the **INITIAL** filing of an application. After the initial filing of an application, an Application Data Sheet cannot be used to provide or rescind authorization for access by a foreign IP office(s). Instead, Form PTO/SB/39 or PTO/SB/69 must be used as appropriate.

### 1. Authorization to Permit Access by a Foreign Intellectual Property Office(s)

**A. Priority Document Exchange (PDX)** - Unless box A in subsection 2 (opt-out of authorization) is checked, the undersigned hereby **grants the USPTO authority** to provide the European Patent Office (EPO), the Japan Patent Office (JPO), the Korean Intellectual Property Office (KIPO), the State Intellectual Property Office of the People's Republic of China (SIPO), the World Intellectual Property Organization (WIPO), and any other foreign intellectual property office participating with the USPTO in a bilateral or multilateral priority document exchange agreement in which a foreign application claiming priority to the instant patent application is filed, access to: (1) the instant patent application-as-filed and its related bibliographic data, (2) any foreign or domestic application to which priority or benefit is claimed by the instant application and its related bibliographic data, and (3) the date of filing of this Authorization. See 37 CFR 1.14(h)(1).

**B. Search Results from U.S. Application to EPO** - Unless box B in subsection 2 (opt-out of authorization) is checked, the undersigned hereby **grants the USPTO authority** to provide the EPO access to the bibliographic data and search results from the instant patent application when a European patent application claiming priority to the instant patent application is filed. See 37 CFR 1.14(h)(2).

The applicant is reminded that the EPO's Rule 141(1) EPC (European Patent Convention) requires applicants to submit a copy of search results from the instant application without delay in a European patent application that claims priority to the instant application.

### 2. Opt-Out of Authorizations to Permit Access by a Foreign Intellectual Property Office(s)

A. Applicant **DOES NOT** authorize the USPTO to permit a participating foreign IP office access to the instant application-as-filed. If this box is checked, the USPTO will not be providing a participating foreign IP office with any documents and information identified in subsection 1A above.

B. Applicant **DOES NOT** authorize the USPTO to transmit to the EPO any search results from the instant patent application. If this box is checked, the USPTO will not be providing the EPO with search results from the instant application.

**NOTE:** Once the application has published or is otherwise publicly available, the USPTO may provide access to the application in accordance with 37 CFR 1.14.



<b>Application Data Sheet 37 CFR 1.76</b>	Attorney Docket Number	E1027.800(T).US1D1C1C3
	Application Number	
Title of Invention	DIRECTED WIRELESS COMMUNICATION	

## Applicant Information:

<p>Providing assignment information in this section does not substitute for compliance with any requirement of part 3 of Title 37 of CFR to have an assignment recorded by the Office.</p>			
<b>Applicant 1</b>			
<p>If the applicant is the inventor (or the remaining joint inventor or inventors under 37 CFR 1.45), this section should not be completed. The information to be provided in this section is the name and address of the legal representative who is the applicant under 37 CFR 1.43; or the name and address of the assignee, person to whom the inventor is under an obligation to assign the invention, or person who otherwise shows sufficient proprietary interest in the matter who is the applicant under 37 CFR 1.46. If the applicant is an applicant under 37 CFR 1.46 (assignee, person to whom the inventor is obligated to assign, or person who otherwise shows sufficient proprietary interest) together with one or more joint inventors, then the joint inventor or inventors who are also the applicant should be identified in this section.</p>			
<input type="button" value="Clear"/>			
<input checked="" type="radio"/> Assignee	<input type="radio"/> Legal Representative under 35 U.S.C. 117	<input type="radio"/> Joint Inventor	
<input type="radio"/> Person to whom the inventor is obligated to assign.	<input type="radio"/> Person who shows sufficient proprietary interest		
If applicant is the legal representative, indicate the authority to file the patent application, the inventor is:			
<input type="text"/>			
Name of the Deceased or Legally Incapacitated Inventor: <input type="text"/>			
If the Applicant is an Organization check here. <input checked="" type="checkbox"/>			
Organization Name	XR Communications, LLC D/B/A Vivato Technologies		
<b>Mailing Address Information For Applicant:</b>			
Address 1	444 South Cedros Avenue		
Address 2	<input type="text"/>		
City	Solana Beach	State/Province	CA
Country <sup>1</sup>	US	Postal Code	92075
Phone Number	<input type="text"/>	Fax Number	<input type="text"/>
Email Address	<input type="text"/>		
Additional Applicant Data may be generated within this form by selecting the Add button.			

<b>Application Data Sheet 37 CFR 1.76</b>		Attorney Docket Number	E1027.800(T).US1D1C1C3
		Application Number	
Title of Invention	DIRECTED WIRELESS COMMUNICATION		

### Assignee Information including Non-Applicant Assignee Information:

Providing assignment information in this section does not substitute for compliance with any requirement of part 3 of Title 37 of CFR to have an assignment recorded by the Office.

<b>Assignee 1</b>				
Complete this section if assignee information, including non-applicant assignee information, is desired to be included on the patent application publication. An assignee-applicant identified in the "Applicant Information" section will appear on the patent application publication as an applicant. For an assignee-applicant, complete this section only if identification as an assignee is also desired on the patent application publication.				
If the Assignee or Non-Applicant Assignee is an Organization check here. <input type="checkbox"/>				
Prefix	Given Name	Middle Name	Family Name	Suffix
<b>Mailing Address Information For Assignee including Non-Applicant Assignee:</b>				
Address 1				
Address 2				
City		State/Province		
Country i		Postal Code		
Phone Number		Fax Number		
Email Address				
Additional Assignee or Non-Applicant Assignee Data may be generated within this form by selecting the Add button.				

Under the Paperwork Reduction Act of 1995, no persons are required to respond to a collection of information unless it contains a valid OMB control number.

<b>Application Data Sheet 37 CFR 1.76</b>		Attorney Docket Number	E1027.800(T).US1D1C1C3
		Application Number	
Title of Invention	DIRECTED WIRELESS COMMUNICATION		

**Signature:**

**NOTE:** This Application Data Sheet must be signed in accordance with 37 CFR 1.33(b). **However, if this Application Data Sheet is submitted with the INITIAL filing of the application and either box A or B is not checked in subsection 2 of the "Authorization or Opt-Out of Authorization to Permit Access" section, then this form must also be signed in accordance with 37 CFR 1.14(c).**

This Application Data Sheet **must** be signed by a patent practitioner if one or more of the applicants is a **juristic entity** (e.g., corporation or association). If the applicant is two or more joint inventors, this form must be signed by a patent practitioner, **all** joint inventors who are the applicant, or one or more joint inventor-applicants who have been given power of attorney (e.g., see USPTO Form PTO/AIA/81) on behalf of **all** joint inventor-applicants.

See 37 CFR 1.4(d) for the manner of making signatures and certifications.

<b>Signature</b>	/Nicholas R. Transier/			Date (YYYY-MM-DD)	
First Name	Nicholas	Last Name	TRANSIER	Registration Number	68743
Additional Signature may be generated within this form by selecting the Add button.					