

(19) Japan Patent Office (JP)

(12) **Japanese Unexamined Patent Application Publication (A)**

(11) Japanese Unexamined Patent Application Publication Number

Japanese Unexamined Patent Application Publication H11-18186

(43) Publication date: January 22, 1999

(51) Int. Cl. ⁶	Identification codes	FI
H 0 4 R 1/40	3 2 0	H 0 4 R 1/40 3 2 0 B
H 0 3 H 21/00		H 0 3 H 21/00
H 0 4 R 3/00	3 2 0	H 0 4 R 3/00 3 2 0

Request for examination: Not yet requested Number of claims: 6 OL (Total of 10 pages)

(21) Application number	Japanese Patent Application No. H9-167812	(71) Applicant	000136848 Primo Company Ltd. 6-25-1 Mure, Mitaka-shi, Tokyo
(22) Application date	June 25, 1997	(72) Inventor	Kimihiro IKEDA % Primo Company Ltd. 6-25-1 Mure, Mitaka-shi, Tokyo
		(72) Inventor	Yasuo MAEKAWA % Primo Company Ltd. 6-25-1 Mure, Mitaka-shi, Tokyo
		(74) Agent	Patent Attorney Shizuyo TAMAMURA

(54) (TITLE OF THE INVENTION) **PRIMARY PRESSURE GRADIENT MICROPHONE**

(57) (ABSTRACT)

(PROBLEM) To provide a primary pressure gradient microphone with which sound from a target sound source in a specific direction can be acquired with good S/N in an environment in which noise is generated from every direction.

(SOLUTION) First and second omnidirectional microphone units (M1, M2) are disposed apart from one another, wherein a difference between a delay signal of the output of the second omnidirectional microphone unit and the output of the first omnidirectional microphone unit is determined by a first adding means (3), and a difference between the output of the second omnidirectional microphone unit and a delay signal of the output of the first omnidirectional microphone unit is determined by a second adding means (4). The outputs of the first and second adding means have directional characteristics in opposite directions so that the directional characteristics of the one facing a target sound source are used to pick up a target sound and noise while the directional characteristics of the other are used to pick up noise, and the difference between the two is taken so as to cancel the noise component.

FIG. 1

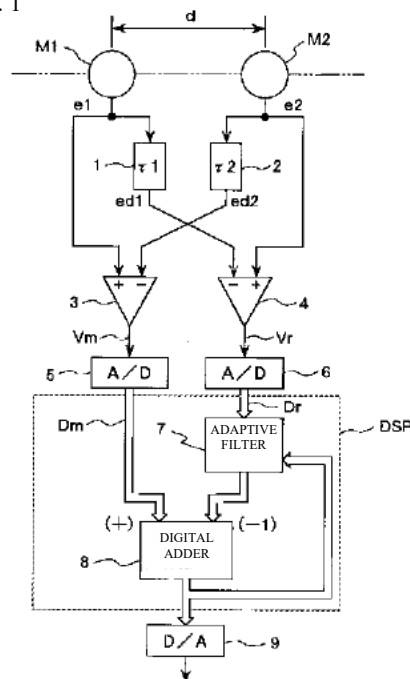

(SCOPE OF THE PATENT CLAIMS)

(CLAIM 1) A primary pressure gradient microphone comprising: first and second omnidirectional microphone units disposed a prescribed distance apart from one another; a first delaying means for delaying an output of the first omnidirectional microphone unit; a second delaying means for delaying an output of the second omnidirectional microphone unit; a first adding means for outputting a difference between an output of the first omnidirectional microphone unit and an output of the second delaying means; and a second adding means for outputting a difference between an output of the second omnidirectional microphone unit and an output of the first delaying means.

(CLAIM 2) A primary pressure gradient microphone comprising: first and second omnidirectional microphone units disposed a prescribed distance apart from one another; a third microphone unit disposed near the second microphone unit; a first delaying means for delaying an output of the first omnidirectional microphone unit; a second delaying means for delaying an output of the second omnidirectional microphone unit; a first adding means for outputting a difference between an output of the first omnidirectional microphone unit and an output of the second delaying means; and a second adding means for outputting a difference between an output of the third omnidirectional microphone unit and an output of the first delaying means.

(CLAIM 3) A primary pressure gradient microphone comprising: first and second omnidirectional microphone units disposed a prescribed distance apart from one another; third and fourth omnidirectional microphone unit disposed a prescribed distance apart from one another in a cross direction with respect to disposing direction of the first and second omnidirectional microphone units; a delaying means for delaying an output of the second omnidirectional microphone unit; a first adding means for adding a difference between an output of the first omnidirectional microphone unit and an output of the delaying means; and a second adding means for outputting a difference between an output of the third omnidirectional microphone unit and an output of the fourth omnidirectional microphone unit.

(CLAIM 4) A primary pressure gradient microphone comprising: first and second omnidirectional microphone units disposed a prescribed distance apart from one another; third and fourth omnidirectional microphone units disposed adjacent to and in identical sequence with the first and second omnidirectional microphone units; a second delaying means for delaying an output of the second omnidirectional microphone unit; a first delaying means for delaying an output of the third omnidirectional microphone unit; a first adding means for outputting a difference between an output of the first omnidirectional microphone unit and an output of the second delaying means; and a second adding means for outputting a difference between an output of the fourth omnidirectional microphone unit and an output of the first delaying means.

(CLAIM 5) The primary pressure gradient microphone according to any one of Claims 1 to 4, further comprising: a first A/D conversion means for converting an output of the first adding means to a digital signal; a second A/D conversion means for converting an output of the second

adding means to a digital signal; and a digital signal processing means for cancelling noise components contained in both an output of the first A/D conversion means and an output of the second A/D conversion means.

(CLAIM 6) The primary pressure gradient microphone according to Claim 5, wherein the digital signal processing means comprises: an adaptive filter means for receiving an output of the second A/D conversion means; and a digital adding means for calculating a difference between an output of the adaptive filter means and an output of the first A/D conversion means.

(DETAILED DESCRIPTION OF THE INVENTION)

(0001)

(TECHNICAL FIELD OF THE INVENTION) The present invention relates to a primary pressure gradient microphone exhibiting two types of unidirectional characteristics using a plurality of omnidirectional microphone units, which exhibits excellent noise component reducing capacity and contributes to the miniaturization of the microphone, and may be effectively applied to a primary pressure gradient microphone for automobile use, for example.

(0002)

(CONVENTIONAL TECHNOLOGY) Previous applications filed by the present applicant (Japanese Unexamined Utility Model Application Publication No. S62-147476 and Japanese Unexamined Utility Model Application Publication No. S64-52393) disclose a primary pressure gradient microphone that achieves unidirectionality using two omnidirectional microphone units of essentially the same performance. In principle, this primary pressure gradient microphone is essentially the same as the configuration illustrated in FIG. 2. Two omnidirectional microphone units M1 and M2 are disposed at a distance d apart from one another, wherein the output of the microphone unit M2 is delayed by τ_2 (τ_2 : amount of delay expressed in terms of distance) by a delay circuit 2, and the difference between the delayed output ed2 and the output e1 of the microphone unit M1 is extracted.

(0003) In a microphone configured in this way, when a sound comes from a direction at an angle θ with respect to the axial direction of the two microphone units M1 and M2, the output V_m of the microphone is given by the following formula:

$$V_m(k, \theta) = e_1 - e_2 d \\ = 2 \cdot e_1 \cdot \sin \{ k (\tau_2 + d \cdot \cos \theta) / 2 \}$$

Here, $k=2\pi/\lambda$ (λ : wavelength of sound), and the sound arriving at the microphone units is a sinusoidal sound wave (sound wave with a sinusoidal wave shape). From the above formula, appropriately setting τ_2 to be smaller than d yields directional characteristics such as those illustrated in FIG. 3.

(0004) To facilitate understanding here, the principle of the aforementioned primary pressure gradient microphone will be described qualitatively with reference to FIG. 6. A case in which $\tau_2=d$ and $\theta=0$ will be used as an example. An observation point corresponding to the output e1(a) of the microphone unit M1 with respect to a sound arriving from the Sa direction is Pe1(a), and an observation point corresponding to the delayed output ed2(a) on the microphone unit M2 side is apparently Ped2(a). An

observation point corresponding to the output e1(b) of the microphone unit M1 with respect to a sound arriving from the opposite direction Sb is Pe1(b), and an observation point corresponding to the delayed output ed2(b) on the microphone unit M2 side is apparently Ped2(b). As is clear from the drawing, because the observation points Pe1(b) and Ped2(b) are the same positions, e1(b)=ed2(b). Therefore, the output Vm of the microphone becomes:

$$V_m(k, \theta) = e1(a) + e1(b) - ed2(a) - ed2(b) \\ = e1(a) - ed2(a)$$

It can be easily understood that unidirectionality is achieved as a result.

(0005)

(PROBLEM TO BE SOLVED BY THE INVENTION) However, the primary pressure gradient microphone described above only has unidirectional characteristics with respect to the front surface side. Accordingly, in an environment in which sound (noise) is generated from all directions (four directions) (an environment in which the noise source cannot be fixed to a specific direction), the input of noise cannot be arrested by attempting to input only sound from a target sound source in a specific direction.

(0006) Therefore, although not publicly known, the present inventors investigated a microphone configured to have two types of directionality by making two of the aforementioned primary pressure gradient microphones 10-1 and 10-2 face opposite directions as one another, as illustrated in FIG. 13. The first microphone 10-1 is made to face a specific target sound source so as to pick up the sound of the target sound source and ambient noise using the unidirectional characteristics thereof. The second microphone 10-2, which is made to face the opposite direction as the first microphone 10-1, picks up only noise using the unidirectional characteristics thereof. By determining the difference between the output of the first microphone 10-1 and the output of the second microphone 10-2, it is possible to reduce noise arriving from all directions and to obtain the target sound.

(0007) As a result of further investigating the technology described above, the present inventors ascertained the following. First, the present inventors ascertained that it is physically impossible to dispose the two primary pressure gradient microphones described above at the same position, and that directional characteristics such as those illustrated in FIG. 14 introduce logical error into the removal of noise components, making it difficult to expect high-precision noise cancellation. Second, the present inventors ascertained that in order to meet the demand for miniaturization, it is necessary to realize a primary pressure gradient microphone which has two types of directional characteristics using fewer than four omnidirectional microphone units.

(0008) The present invention was conceived in light of the circumstances described above, and an object thereof is to provide a primary pressure gradient microphone that exhibits an excellent noise cancelling effect and with which two types of directionality can be achieved using four or fewer omnidirectional microphone units.

(0009) Another object of the present invention is to provide a primary pressure gradient microphone with which a

sound from a target sound source in a specific direction can be acquired with good S/N in an environment in which noise is generated from every direction.

(0010) The aforementioned and other objects and novel features of the present invention will be clear from the descriptions of this specification and the attached drawings. (0011)

(MEANS FOR SOLVING THE PROBLEM) As illustrated in FIG. 1, the best primary pressure gradient microphone according to the present invention achieves two types of directional characteristics using two omnidirectional microphone units, and comprises: first and second omnidirectional microphone units (M1, M2) disposed a prescribed distance apart from one another; a first delaying means (1) for delaying an output of the first omnidirectional microphone unit; a second delaying means (2) for delaying an output of the second omnidirectional microphone unit; a first adding means (3) for outputting a difference between an output of the first omnidirectional microphone unit and an output of the second delaying means; and a second adding means (4) for outputting a difference between an output of the second omnidirectional microphone unit and an output of the first delaying means.

(0012) When the first omnidirectional microphone unit (M1) is defined as the front surface of the microphone, a signal system for obtaining the output of the first adding means (3) is made by the two microphone units (M1, M2) to function as a main microphone (see FIGS. 2 and 3) having directional characteristics on the front surface side, and a signal system for obtaining the output of the second adding means (4) is made by the two microphone units (M1, M2) to function as a reference microphone having directional characteristics on the back surface side. In an environment in which noise is generated from every direction so that a noise source cannot be specified, the main microphone facing the target sound source picks up the target sound and noise, and the reference microphone picks up only noise. By determining the difference between the output signal component of the main microphone and the output signal component of the reference microphone, the noise components can be cancelled. At this time, the main microphone and the reference microphone are configured using the same microphone units (M1, M2), so both of the microphones can be considered to be disposed at physically the same position. In other words, the noise components picked up by both of the microphones can be considered to be essentially the same. It is therefore possible to acquire only the target sound component with high S/N.

(0013) Essentially the same functions as those described above can be realized using three omnidirectional microphone units. That is, as illustrated in FIG. 8, a third omnidirectional microphone unit (M3) is disposed near the second omnidirectional microphone unit, the main microphone is as described above, and the reference microphone is configured to obtain the difference between the output of the first delaying means (1) and the output of the third microphone unit with the second adding means. As a result, a primary pressure gradient microphone having two types of directional characteristics can be realized with three microphone units. Although the positions of the main

microphone and the reference microphone cannot be considered to be exactly the same, the second microphone unit and the third microphone unit can be disposed near one another without any distance therebetween, so a good noise cancelling effect can be achieved.

(0014) Essentially the same functions as those described above can be realized using four omnidirectional microphone units. That is, as illustrated in FIG. 9, third and fourth omnidirectional microphone units (M3, M4) are disposed a prescribed distance apart from one another in a cross direction with respect to the disposing direction of the first and second omnidirectional microphone units; the difference between the output of the delaying means for delaying the output of the second omnidirectional microphone unit and the output of the first omnidirectional microphone unit is determined by the first adding means; and the difference between the output of the third omnidirectional microphone unit and the output of the fourth omnidirectional microphone unit is determined by the second adding means. Although the number of microphone units is four, the main microphone and the reference microphone can be logically considered to be positioned in the center of the four microphone units disposed radially, which makes it possible to achieve an excellent noise cancelling effect.

(0015) Further, when four omnidirectional microphone units are used, as illustrated in FIG. 12, the main microphone and the reference microphone configured from two omnidirectional microphone units are configured from different omnidirectional microphone units (M1 to M4). That is, the main microphone is configured using the first and second omnidirectional microphone units (M1, M2), and the reference microphone is configured using the third and fourth omnidirectional microphone units (M3, M4). The main microphone has directional characteristics on the front surface side, and the reference microphone has directional characteristics on the back surface side. At this time, the sequence of the third and fourth omnidirectional microphone units is identical to the sequence of the first and second omnidirectional microphone units, and the first and second omnidirectional microphone units are disposed adjacent to the third and fourth omnidirectional microphone units. Therefore, the difference in sound fields between noise picked up by the main microphone and noise picked up by the reference microphone is minimized, which makes it possible to acquire the target sound with relatively good S/N.

(0016) Although the processing for cancelling noise using the outputs of the first and second adding means can also be performed with an analog technique, the configuration further comprises the following when a digital technique is used: a first A/D conversion means (5) for converting the output of the first adding means to a digital signal; a second A/D conversion means (6) for converting the output of the second adding means to a digital signal; and a digital signal processing means for cancelling the noise components contained in both the output of the first A/D conversion means and the output of the second A/D conversion means.

(0017) The digital signal processing means comprises: an adaptive filter means (7) for receiving the output of the second A/D conversion means (6); and a digital adding means (8) for calculating the difference between the output

of the adaptive filter means and the output of the first A/D conversion means.

(0018) An example of the primary pressure gradient microphone according to the present invention is illustrated in FIG. 1. In the microphone illustrated in the drawing, two omnidirectional microphone units M1 and M2 having essentially the same performance are disposed at a distance d apart from one another, wherein the output $e1$ of the microphone unit M1 is delayed by $\tau1$ ($\tau1$: amount of delay expressed in terms of distance) by a delay circuit 1, and the output $e2$ of the microphone unit M2 is delayed by $\tau2$ ($\tau2$: amount of delay expressed in terms of distance) by a delay circuit 2. Also provided are an inversion adding circuit 3 for calculating the difference between the output $e1$ of the microphone unit M1 and the output $ed2$ of the delay circuit 2, and an inversion adding circuit 4 for calculating the difference between the output $e2$ of the microphone unit M2 and the output $ed1$ of the delay circuit 1. The inversion adding circuits 3 and 4 may be formed, for example, from operational amplifiers, feedback resistors, and input resistors, where the non-inverted inputs (+) are defined as $e1$ and $e2$, and the inverted inputs (-) are defined as $ed2$ and $ed1$.

(0019) The microphone is housed in a casing, not illustrated, so that the microphone unit M1 is disposed on the front surface. Ceramic or electrolyte-type microphone units or the like may be used for the microphone units M1 and M2.

(0020) At this time, the microphone can be understood as two types of primary pressure gradient microphones including the main microphone of FIG. 2 having a signal path for obtaining a main signal Vm from the inversion adding circuit 3 and the reference microphone of FIG. 4 having a signal path for obtaining a reference signal Vr from the inversion adding circuit 4.

(0021) The main microphone has directional characteristics on the front surface side, and therefore has directional characteristics for picking up a target sound and noise from the front surface side. The main signal Vm is given as follows:

$$V_m(k, \theta) = e1 - ed2 \\ = 2 \cdot e1 \cdot \sin \{ k(\tau2 + d \cdot \cos \theta) / 2 \}$$

(0022) The main microphone, which can be understood as illustrated in FIG. 2, has directional characteristics with respect to the front surface side and has the directional characteristics illustrated in FIG. 3. The fact that such directional characteristics are achieved can be understood from the content described qualitatively above with reference to FIG. 6.

(0023) The reference microphone has directional characteristics on the back surface side, and therefore has directional characteristics for picking up noise from the back surface side without picking up the target sound and noise from the front surface side. The reference signal Vr is given as follows:

$$V_r(k, \theta) = e2 - ed1 \\ = -2 \cdot e1 \cdot \sin \{ k(\tau1 + d \cdot \cos \theta) / 2 \}$$

Here, in the two formulas above, $k=2\pi/\lambda$ (λ : wavelength of sound), and the characteristics of the two omnidirectional microphone units M1 and M2 are essentially the same. The

arriving sound wave is assumed to be a sinusoidal sound wave.

(0024) The reference microphone illustrated in FIG. 4 has directional characteristics with respect to the back surface side, as illustrated in FIG. 5. The fact that such directional characteristics are achieved will be described qualitatively with reference to FIG. 7. That is, in order to facilitate understanding in FIG. 7, a case in which $\tau_1=d$ and $\theta=0$ will be used as an example. An observation point corresponding to the delayed output $e_{d1}(a)$ on the microphone unit M1 side with respect to a sound arriving from the Sa direction is apparently $Pe_{d1}(a)$, and an observation point corresponding to the output $e_{2(a)}$ of the microphone unit M2 is $Pe_{2(a)}$. An observation point corresponding to the delayed output $e_{d1}(b)$ of the microphone unit M1 with respect to a sound arriving from the opposite direction Sb is apparently $Pe_{d1}(b)$, and an observation point corresponding to the output $e_{2(b)}$ of the microphone unit M2 is $Pe_{2(b)}$. As is clear from the drawing, because the observation points $Pe_{d1}(a)$ and $Pe_{2(a)}$ are the same positions, $e_{d1}(a)=e_{2(a)}$. Therefore, the output V_r of the reference microphone becomes:

$$E(k, \theta) = e_{2(b)} + e_{2(a)} - e_{d1(a)} - e_{d1(b)} \\ = e_{2(b)} - e_{d1(b)}$$

This makes it possible to achieve unidirectionality on the back surface side.

(0025) As described above, a main microphone and a reference microphone with respectively different directional characteristics are realized by commonly using two omnidirectional microphone units M1 and M2, so this is equivalent to a case in which the main microphone and the reference microphone having different directional characteristics are disposed at physically the same position. Accordingly, the microphone illustrated in FIG. 1 picks up sounds of different components of the same sound field. On the other hand, as illustrated in FIG. 13, when the main microphone and the reference microphone are each configured using two different omnidirectional microphone units, both microphones are disposed at physically different positions, as illustrated in FIG. 14. Therefore, both microphones pick up sounds different components of different sound fields separated by a prescribed distance. In the configuration illustrated in FIG. 13, there are differences that cannot be ignored between the components of sounds picked up by the microphones 10-1 and 10-2 disposed apart from one another in an environment in which noise is generated from every direction. In the case of FIG. 1, the main microphone and the reference microphone are in exactly the same sound field, so the noise components picked up by both of the microphones can be considered to be essentially the same, even in an environment in which noise is generated from every direction.

(0026) FIG. 10 illustrates an example of a polar pattern expressing the directional characteristics achieved by combining the respective directional characteristics of the main microphone and the reference microphone. In this example, $\tau_2=d/3$ and $\tau_1=d$. As is clear from this polar pattern, the primary pressure gradient microphone

consisting of the main microphone and the reference microphone achieves two types of directional characteristics on the front surface side and the back surface side with the two microphone units M1 and M2.

(0027) The output V_m of the inversion adding circuit 3 is converted to a digital signal D_m by an A/D converter 5, and the output V_r of the inversion adding circuit 4 is converted to a digital signal D_r by an A/D converter 6. Main signal data D_r outputted from the A/D converter 6 is supplied to an adaptive filter 7 such as a transversal filter, and the difference between the filter output of the adaptive filter 7 and the main signal data D_m outputted from the A/D converter 5 is calculated by a digital adder 8.

(0028) The adaptive filter 7 is a filter that adaptively varies its characteristics with respect to changes in the input signal over time. That is, the filter characteristics are varied in real time by performing an output operation for obtaining filter output by multiplying the input signal D_r by a tap coefficient and adding the value in multiple tap units, and a tap coefficient updating operation for updating the tap coefficient based on an error signal obtained as the difference between the filter output and a signal from the target system to return the filter output, and successively rewriting the tap coefficient using the updating operation. The error signal is defined as the output of the digital adder 8 at a training sequence timing for determining the filter response characteristics. The training sequence timing is defined as a timing at which the microphone units M1 and M2 do not pick up the target sound. Therefore, the filter response characteristics of the adaptive filter 7 are determined so as to cancel the respective noise components contained in the main signal data D_m and the reference signal data D_r at the training sequence timing. The training sequence is successively performed at an appropriately timing so as to follow the state in which the noise generation state of the sound field is varied from moment to moment.

(0029) As a result of the response characteristics of the adaptive filter 7 being determined successively in this way, the noise component contained in the main signal V_m is cancelled by the noise component contained in the reference signal V_r due to subtraction by digital adder 8. The output of the digital adder 8 is converted to an analog signal by a D/A converter 9. A signal primarily consisting of the target sound component can be acquired from the D/A converter 9. As a result of creating and testing a prototype of the circuit illustrated in FIG. 1 having the directional characteristics illustrated in FIG. 10, the S/N was improved by approximately 10 dB in comparison to a conventional primary pressure gradient microphone configured to obtain single directionality with two omnidirectional microphone units.

(0030) Note that the adaptive filter 7, the digital adder 8, and the like can be configured a digital signal processor DSP. In addition, a low pass filter for removing high-frequency components may be disposed at the stage preceding the A/D converters 5 and 6.

(0031) FIG. 8 illustrates an example of a case in which a primary pressure gradient microphone equivalent to that described above is configured using three omnidirectional microphone units. That is, a third omnidirectional microphone unit M3 is disposed near the omnidirectional

Explore Litigation Insights

Docket Alarm provides insights to develop a more informed litigation strategy and the peace of mind of knowing you're on top of things.

Real-Time Litigation Alerts



Keep your litigation team up-to-date with **real-time alerts** and advanced team management tools built for the enterprise, all while greatly reducing PACER spend.

Our comprehensive service means we can handle Federal, State, and Administrative courts across the country.

Advanced Docket Research



With over 230 million records, Docket Alarm's cloud-native docket research platform finds what other services can't. Coverage includes Federal, State, plus PTAB, TTAB, ITC and NLRB decisions, all in one place.

Identify arguments that have been successful in the past with full text, pinpoint searching. Link to case law cited within any court document via Fastcase.

Analytics At Your Fingertips



Learn what happened the last time a particular judge, opposing counsel or company faced cases similar to yours.

Advanced out-of-the-box PTAB and TTAB analytics are always at your fingertips.

API

Docket Alarm offers a powerful API (application programming interface) to developers that want to integrate case filings into their apps.

LAW FIRMS

Build custom dashboards for your attorneys and clients with live data direct from the court.

Automate many repetitive legal tasks like conflict checks, document management, and marketing.

FINANCIAL INSTITUTIONS

Litigation and bankruptcy checks for companies and debtors.

E-DISCOVERY AND LEGAL VENDORS

Sync your system to PACER to automate legal marketing.