



- [54] **HEAD-MOUNTED PERSONAL VISUAL DISPLAY APPARATUS WITH IMAGE GENERATOR AND HOLDER**
- [75] Inventors: **Richard Dennis Rallison**, Paradise, Utah; **C. Gregory Amadon**, Seattle, Wash.; **Wolfgang Adam Mack, Jr.**, Seattle, Wash.; **Leo Nikora**, Bellevue, Wash.; **Eric Tseo**, Seattle, Wash.; **Douglas Donaldson**, Bothell, Wash.; **Robert T. Etter**, Bonney Lake, Wash.
- [73] Assignee: **i-O Display Systems LLC**, Menlo Park, Calif.

[21] Appl. No.: **08/686,843**
 [22] Filed: **Jul. 12, 1996**

Related U.S. Application Data

- [63] Continuation of application No. PCT/US95/11344, Aug. 31, 1995, which is a continuation-in-part of application No. 08/416,919, Apr. 21, 1995, Pat. No. 5,903,395
- [60] Provisional application No. 60/001,151, Jul. 14, 1995.
- [51] **Int. Cl.⁶** **G02B 27/14; G09G 5/00**
- [52] **U.S. Cl.** **359/630; 345/8**
- [58] **Field of Search** **359/630, 631, 359/633; 345/7, 8; 351/114, 115**

References Cited

U.S. PATENT DOCUMENTS

- D. 300,476 3/1989 Sestak D29/18
- D. 301,644 6/1989 Sestak D29/18
- D. 334,557 4/1993 Hunter et al. D14/114
- D. 334,742 4/1993 Hunter et al. D14/113
- D. 337,320 7/1993 Hunter et al. D14/113

(List continued on next page.)

FOREIGN PATENT DOCUMENTS

- 0 059 770 9/1982 European Pat. Off. G01R 33/04
- 0 460983 A1 5/1991 European Pat. Off. G02B 27/00
- 0 453 347 10/1991 European Pat. Off. G01V 3/08

(List continued on next page.)

OTHER PUBLICATIONS

Aley et al., "A Sourceless Orientation Sensor", *Sensors*, Nov. 1993, p. 55.
 Analog Devices, Inc., "Analog Devices", specifications, 1995, pp. 1, 3, 5, 7, 9, 11, 13, 15, 17, 19.

(List continued on next page.)

Primary Examiner—Georgia Epps
Assistant Examiner—Ricky Mack
Attorney, Agent, or Firm—Sheridan Ross P.C.

[57] **ABSTRACT**

A visual display device is provided for delivering a generated image, preferably combinable with environment light, to the eye of a user. The device is lightweight and compact but yields a high quality image. In one embodiment, a shroud protects from stray light and holds optical elements in desired alignment. In one embodiment an image generator is masked by at least two masks to provide for a high quality image without waste. In one embodiment, a removably mounted shield or activatable device and convert the apparatus from a see-through device to an immersion device and back again. In one embodiment, the device can be comfortably mounted to the user's head while still allowing for use of conventional eyeglasses. A tracker for outputting an indication of the orientation, attitude and/or position of a head-mounted display (HMD) may be provided. The tracker can be configured so that it is incorporated in the HMD housing and/or can be easily decoupled from the HMD, so that the HMD can be used without the tracker (e.g. for watching movies). Preferably, decoupling involves unplugging a single electrical connector (such as a cable) and unfastening a mechanical connection (such as a strap). Preferably the tracker provides pass-through of signal to the HMD and, when the tracker is coupled to the HMD, only a single cable or other data link connects the HMD-tracker combination to the host computer. In one embodiment, the tracker uses magnetic sensors. In another embodiment, one or more inertial sensors, such as a rate gyro and/or accelerometers are used.

22 Claims, 32 Drawing Sheets

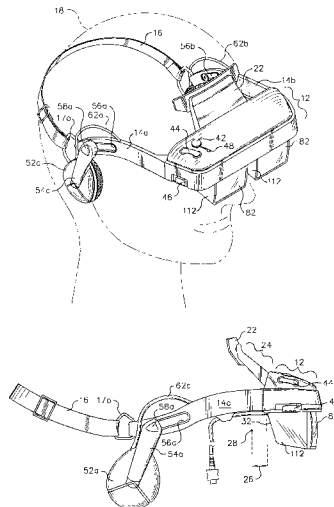

U.S. PATENT DOCUMENTS

D. 338,514	8/1993	Holmes	D21/240	4,561,723	12/1985	Hamano et al.	350/331 R
2,411,933	12/1946	Morley et al.	2/14	4,571,628	2/1986	Thornton	358/224
2,581,428	1/1952	McCarthy	33/224	4,590,680	5/1986	Hanchett et al.	33/366
2,581,436	1/1952	McCarthy	318/24	4,614,041	9/1986	Darton et al.	33/313
2,585,956	2/1952	McCarthy	33/224	4,621,283	11/1986	Feinbloom	358/93
2,955,156	10/1960	Heilig	178/6.5	4,622,644	11/1986	Hansen	364/559
2,958,258	11/1960	Kelly	88/24	4,622,843	11/1986	Hormel	73/1 E
3,043,910	7/1962	Hicks	178/7.85	4,630,321	12/1986	Sagemuehl et al.	2/426
3,212,102	10/1965	Müller	2/12	4,633,324	12/1986	Giulie	358/255
3,232,561	2/1966	Adams	244/1	4,636,866	1/1987	Hattori	358/236
3,355,942	12/1967	Freeman	73/178	4,641,931	2/1987	Loy	350/538
3,405,355	10/1968	Hebbert	324/46	4,642,786	2/1987	Hansen	364/559
3,434,219	3/1969	Bowman	33/205	4,651,201	3/1987	Schoolman	358/98
3,487,299	12/1969	Hart et al.	324/43	4,652,870	3/1987	Steward	340/705
3,573,610	4/1971	Kesselring	324/43	4,667,414	5/1987	Russell	33/364
3,584,388	6/1971	Petrov et al.	33/225	4,680,866	7/1987	Johnson et al.	33/356
3,589,795	6/1971	Miyazaki et al.	350/96 B	4,682,159	7/1987	Davison	340/709
3,614,314	10/1971	Rossire	178/7.88	4,694,583	9/1987	Blaney	33/361
3,621,584	11/1971	Burt	33/224	4,695,129	9/1987	Faessen et al.	350/96.25
3,629,870	12/1971	Paisley	2/15	4,703,522	11/1987	Schürle et al.	2/432
3,737,212	6/1973	Antonson et al.	350/174	4,706,117	11/1987	Schoolman	358/88
3,825,911	7/1974	Burns	340/198	4,711,512	12/1987	Upatnieks	350/3.7
3,833,901	9/1974	Fowler	340/347 P	4,720,992	1/1988	Hormel	73/1 E
3,874,783	4/1975	Cole	350/96 B	4,722,601	2/1988	McFarlane	356/152
3,888,016	6/1975	Fowler	33/346	4,726,075	2/1988	Hinrichs	2/13
3,905,121	9/1975	Takeda et al.	33/361	4,737,972	4/1988	Schoolman	378/41
3,915,548	10/1975	Opitek et al.	350/3.5	4,743,200	5/1988	Welch et al.	434/43
3,923,370	12/1975	Moström	350/55	4,751,746	6/1988	Rustin	2/13
3,940,204	2/1976	Withrington	350/3.5	4,753,514	6/1988	Kubik	350/174
3,983,474	9/1976	Kuipers	324/43 R	4,757,714	7/1988	Purdy et al.	73/597
4,017,858	4/1977	Kuipers	343/100 R	4,761,056	8/1988	Evans et al.	350/174
4,021,862	5/1977	Glasser et al.	2/431	4,763,990	8/1988	Wood	350/320
4,026,641	5/1977	Bosserman et al.	350/298	4,775,217	10/1988	Ellis et al.	350/538
4,028,725	6/1977	Lewis	358/103	4,784,468	11/1988	Tierney	350/276 R
4,042,957	8/1977	Ellis	358/109	4,785,481	11/1988	Palmer et al.	2/436
4,048,653	9/1977	Spooner	358/104	4,786,966	11/1988	Hanson et al.	358/108
4,060,910	12/1977	Gell, Jr.	33/324	4,791,729	12/1988	Suda	33/356
4,095,348	6/1978	Kramer	33/363 K	4,792,761	12/1988	King et al.	324/350
4,103,435	8/1978	Herndon	35/12 N	4,796,987	1/1989	Linden	351/158
4,104,803	8/1978	Hoeppel	33/352	4,797,736	1/1989	Kloots et al.	358/93
4,139,951	2/1979	Cunard et al.	33/362	4,799,765	1/1989	Ferrer	350/174
4,146,970	4/1979	Edwards	33/363 K	4,805,988	2/1989	Dones	350/137
4,157,619	6/1979	Zuvela	33/352	4,806,011	2/1989	Bettinger	351/158
4,179,741	12/1979	Rossani	364/457	4,807,202	2/1989	Cherri et al.	367/129
4,257,062	3/1981	Meredith	358/81	4,807,462	2/1989	Al-Attar	73/1 E
4,269,476	5/1981	Gauthier et al.	350/174	4,817,633	4/1989	McStravick et al.	128/782
4,303,394	12/1981	Berke et al.	434/40	4,826,287	5/1989	Cook et al.	350/174
4,310,849	1/1982	Glass	358/88	4,839,809	6/1989	Leighton et al.	364/413.02
4,322,135	3/1982	Freeman	350/410	4,849,696	7/1989	Brun et al.	324/252
4,341,023	7/1982	Marcus et al.	33/363 K	4,851,775	7/1989	Kim et al.	324/247
4,347,507	8/1982	Spooner	340/705	4,853,764	8/1989	Sutter	358/3
4,348,185	9/1982	Breglia et al.	434/43	4,859,030	8/1989	Rotier	350/174
4,361,384	11/1982	Bosserman	350/174	4,859,031	8/1989	Berman et al.	350/174
4,385,803	5/1983	Ellis	350/174	4,863,242	9/1989	Correa	350/276 R
4,395,731	7/1983	Schoolman	358/88	4,864,190	9/1989	Orr	313/478
4,398,799	8/1983	Swift	350/174	4,865,420	9/1989	Schmidt	350/276 R
4,435,760	3/1984	Kuno et al.	364/444	4,867,551	9/1989	Perera	351/158
4,437,113	3/1984	Lee et al.	358/93	4,868,930	9/1989	Blackstone	2/439
4,439,157	3/1984	Breglia et al.	434/40	4,869,575	9/1989	Kubik	350/174
4,446,480	5/1984	Breglia et al.	358/104	4,874,214	10/1989	Cheyason et al.	350/3.7
4,465,347	8/1984	Task et al.	350/538	4,874,235	10/1989	Webster	351/201
4,468,101	8/1984	Ellis	350/538	4,884,137	11/1989	Hanson et al.	358/108
4,484,191	11/1984	Vavra	340/965	4,884,219	11/1989	Waldren	364/514
4,497,034	1/1985	Kuno et al.	364/571	4,897,715	1/1990	Beamon	358/93
4,521,777	6/1985	Nakamura et al.	340/995	4,900,133	2/1990	Berman	350/346
4,539,760	9/1985	Marchent et al.	33/356	4,902,083	2/1990	Wells	350/6.6
4,546,550	10/1985	Marchent et al.	33/356	4,902,116	2/1990	Ellis	350/501
4,546,551	10/1985	Franks	33/356	4,902,120	2/1990	Weyer	351/158
4,550,984	11/1985	Reymond	350/404	4,904,049	2/1990	Hegg	350/96.27
4,559,555	12/1985	Schoolman	358/88	4,930,888	6/1990	Freisleben et al.	356/152
					4,932,731	6/1990	Suzuki et al.	350/3.7
					4,933,755	6/1990	Dahl et al.	358/88

1485015	6/1989	U.S.S.R.	G01C	17/00
1560091	4/1990	U.S.S.R.	A61B	5/103
1607775	11/1990	U.S.S.R.	A61B	5/11
1616603	12/1990	U.S.S.R.	A61B	5/103
1700573	12/1991	U.S.S.R.	G09B	9/04
2 093 591	9/1982	United Kingdom	G01C	17/28
2 117 609	10/1983	United Kingdom	G09B	9/00
2 143 948	2/1985	United Kingdom	G01C	1/00
2 157 426	10/1985	United Kingdom	G01B	11/26
2 164 748	3/1986	United Kingdom	G01C	17/08
2 177 512	1/1987	United Kingdom	G01C	17/28
2 179 543	3/1987	United Kingdom	.		
2 195 180	3/1988	United Kingdom	G01C	17/04
2266385A	10/1993	United Kingdom	G02B	23/10
2270775A	3/1994	United Kingdom	G02B	27/02
2 279 201	12/1994	United Kingdom	H04R	1/10
2 281 846	3/1995	United Kingdom	A45F	3/00
84/01680	4/1984	WIPO	H04N	5/64
WO 92/01276	1/1992	WIPO	G09B	9/10
WO 92/03756	3/1992	WIPO	G02B	27/00
WO 92/15078	9/1992	WIPO	G09B	9/00
WO 92/21117	11/1992	WIPO	G09B	9/34
93/23783	11/1993	WIPO	.		
WO 94/11855	5/1994	WIPO	G09G	3/02
WO 94/14152	6/1994	WIPO	G09G	3/02
WO 95/21395	8/1994	WIPO	G02B	27/01
WO 94/24658	10/1994	WIPO	G09G	3/02
WO 95/10061	4/1995	WIPO	G02B	26/10
WO 95/10106	4/1995	WIPO	G09G	3/02

OTHER PUBLICATIONS

- Antonoff, "Living in a Virtual World", *Popular Science*, Jun. 1993, pp. 83-86, 124-125.
- Applewhite, "Position Tracking in Virtual Reality", *Beyond the vision: the technology, research, and business of virtual reality*, Proceedings of Virtual Reality '91, the Second Annual Conference on Virtual Reality, Artificial Reality, and Cyberspace, 1991 San Francisco, pp. 1-8.
- Black, "Digi-Compass, Is your house rotating . . . what about your computer?", *Radio Electronics*, Nov. 1989, pp. 43-45, 50-51, 82.
- Bridges, "Three-dimensional displays in the future flight station", *SPIE*, vol. 507, 1984, pp. 143-154.
- Brooks, "Head Sensor Ideas", Oxford University, Nov. 22, 1991.
- Burley et al., "A full-color wide-field-of-view holographic helmet-mounted display for pilot/vehicle interface development and human factors studies", *SPIE*, vol. 1290, 1990, pp. 9-15.
- Caristi, "Build An Electronic Compass", *Radio Electronics*, Jun. 1991, pp. 39-42.
- Carr, "Is Virtual Reality Virtually Here?", *Training & Development*, Oct. 1992, pp. 37-41.
- Casey et al., "Survey of Available Head Tracking Technology", *PCVR*, vol. 1, Issue 5, Sep./Oct. 1992, pp. 2-11.
- Clarke, "Cheap Head Orientation Sensors", University of Central Florida, Nov. 25, 1991.
- Clarke, "Hybrid Approaches to Orthogonal Localization and Orientation Systems", Small Business Innovation Research Program, Proposal Cover Sheet and Project Summary, Jan. 9, 1992.
- Clarke, "Keeping Your Virtual Feet on the Ground", *PCVR*, Issue 13, Jan./Feb. 1994, pp. 13-24.
- Deering, "High Resolution Virtual Reality", *Computer Graphics*, 26, 2, Jul. 1992, pp. 195, 197, 201.
- "Electrical Devices", Dinsmore No. 1525 Analog Sensor, *R & D Magazine*, Oct. 1991.
- Extance et al., "GaAs Magnetic Field Sensors", *IEEE*, 1985, p. 304-307.
- Ferrin, "Survey of helmet tracking technologies", *SPIE*, vol. 1456, 1991, p. 86-94.
- Fisher et al., "Living in a Virtual World", *Byte*, Jul. 1990, pp. 215-216, 218, 220-221.
- Foley, Interfaces for Advanced Computing, *Scientific American*, Oct. 1987, vol. 257, No. 4, pp. 126-135.
- The Fredericks Co., specifications, memoranda, and graphs, Nov. 16, 1992.
- Garner, "Forum Building the Smart Compass", Oshkosh 1986, Hampton, Virginia, 1986.
- Gottschalk, et al., "Autocalibration for Virtual Environments Tracking Hardware", Computer Graphics Proceedings, Annual Conference Series, 1993, pp. 65-72.
- Grenoble, "Sensor and logic form digital compass", Dinsmore No. 1490 Digital Sensor, *EDN*, Dec. 6, 1990.
- Honeywell, "One-Axis Magnetoresistive Microcircuit HMC1001", specifications, Mar. 1995.
- Honeywell, "Two-Axis Magnetoresistive Microcircuit HMC1002", specifications, Mar. 1995.
- Horn, "Seeing the invisible", *U.S. News & World Report*, Jan. 28, 1991, pp. 56-58.
- James, "Goggles Brighten Dark Subway", *The New York Times*, Apr. 10, 1992.
- Jones et al., "Evaluation of conformal and body-axis attitude information for spatial awareness", *SPIE*, vol. 1695, 1992, pp. 146-153.
- Kopin Corporation, "Kopin Corporation Affiliate Announces Strategic Alliance With Marubeni Australia Ltd.; Marubeni to Distribute Forte Technologies' VFX1(TM) in the Far East and Pacific Rim Markets", *Business Wire*, May 31, 1995.
- Krueger, *Artificial Reality*, 1983 Addison-Wesley Publishing Company, pp. 67-68.
- Krueger, *Artificial Reality II*, 1991 Addison-Wesley Publishing Company, Inc., pp. 66-82, 102-116, 130-149, 179-182, 237-239, 267-279.
- Lancaster, "Hardware Hacker, A solid-state digital compass", *Radio-Electronics*, Dec. 1988, pp. 33-36, 96.
- Lindquist, "Demo 92: From the practical to the playful", *Computerworld*, Feb. 10, 1992, p. 37.
- Merritt et al., "Stereoscopic Displays and Applications II", *SPIE*, vol. 1457, 1991, pp. 327-343.
- Merritt et al., "Stereoscopic Displays and Applications III", *SPIE*, vol. 1669, 1992, pp. 84-89.
- Meyer et al., "A Survey of Position Trackers", *Presence*, vol. 1, No. 2, Spring 1992, p. 173-200.
- Micronta, Service Manual, Flux-Gate Electronic Compass Catalog No.: 63-641, 1992, pp. 1-12.
- Miller, "Online Interviews Dr. Thomas A. Furness III, Virtual Reality Pioneer", *ONLINE*, Nov. 1992, pp. 14-15, 17-18, 20-22, 24-27.
- Noble, "Electronic fluxgate compass", *Electronics World & Wireless World*, Jan. 1992.
- Ono-Sendai Corporation, Specifications, Dec. 22, 1993.
- Petersen, "Magnetoresistive sensors for navigation", *IMEchE*, C391/028, 1989, pp. 87-92.
- Philips Semiconductors, "Magnetic field sensor", Product specification, KMZ10B, Oct. 1994, p. 61, 64.
- Pietila et al., "Vector Magnetometer as an Attitude Determining Instrument", NASA Grant NGR 05-017-031, Research Report, Dec. 27, 1974, pp. 1-16.

- Primdahl, "The fluxgate magnetometer", *Journal of Physics E: Scientific Instruments*, vol. 12, No. 4, Apr. 1979, pp. 241-253.
- Raab et al., "Magnetic Position and Orientation Tracking System", *IEEE*, vol. AES-15, No. 5, Sep. 1979, p. 709-718.
- Raman, "Magnetic heading sensor", *Electronics & Wireless World*, Oct. 1988, pp. 1023-1024.
- Smith, "VA to Test PC System for Handicapped", *Government Computer News*, vol. 9, No. 6, Mar. 19, 1990, p. 114, ISSN 0738-4300.
- Stewart, "Through the looking glass into an artificial world—via computer", *Smithsonian*, vol. 21, No. 10, Jan. 1991, pp. 36-45.
- Sutherland, "A head-mounted three dimensional display", Fall Joint Computer Conference, 1968, pp. 757-763.
- Travers, "Consumer Markets—The Cybermax HMD", *Virtual Reality*, 1994.
- "Virtual Reality Resource Guide", *AI Expert*, Aug. 1992, pp. 42-47.
- "Airlines Weigh Benefits, Costs of At-Seat Video", *Aviation Week & Space Technology*, Aug. 15, 1994, pp. 44-45.
- Antonorff, "Real estate is cheap here, but the places you'd most want to visit are still under construction", *Popular Science*, Jun. 1993, pp. 83-86, 124-125.
- Assenheim et al., "Large-Screen-Projection, Avionic, and Helmet-Mounted Displays", Proceedings, The International Society for Optical Engineering, Feb. 26-28, 1991, vol. 1456, pp. 179-180.
- Benton, "Practical Holography VIII", Proceedings, The International Society for Optical Engineering, Feb. 7-9, 1991, vol. 2176, pp. 241-248.
- Burley, et al., "A full-color wide-field-of-view holographic helmet-mounted display for pilot/vehicle interface development and human factors studies", *SPIE*, vol. 1290 Helmet-Mounted Displays II (1990), pp. 9-15.
- Driscoll et al., *Handbook of Optics*, McGraw-Hill Book Company, 1978, p. 13-6.
- Farmer, "The right solution to the right problem . . . now", *Comdex Daily*, Nov. 15, 1994, p. 4.
- Fischer, "Fundamentals and Optics for Head Mounted Displays", Photonics West '95, Feb. 4-10, 1995.
- Horn, "Seeing the invisible", *U.S. News & World Report*, Jan. 28, 1991.
- Pope, "Say ahhh! Videos help you relax", *The Times-Picayune*, Oct. 25, 1994, pp. 1, A-6.
- Rotier, "Optical Approaches to the Helmet Mounted Display", *SPIE*, 1989, vol. 1116, pp. 14-17.
- Siggraph, *Nikkei Electronics*, Aug. 22, 1994, pp. 13-14.
- Starks, "Stereoscopic video and the quest for virtual reality: an annotated bibliography of selected topics", *SPIE*, vol. 1457 Stereoscopic Displays and Applications II (1991), pp. 327-343.
- "Survey of Head Mounted Displays", *Real Time Graphics*, Aug. 1994, vol. 3, No. 2, pp. 1, 8-12.
- Virtual I/O, "i-glasses!", *Twice CES Daily*, Jan. 6, 1995, p. 30.
- Virtual I/O. Specifications, *Virtual Reality World*, Nov./Dec. 1994, p. 11.
- Virtual I/O, *VR News*, "Tele-Communications Inc. to market test Virtual I/O HMDs for cable TV applications", Aug./Sep. 1994, p. 17.
- VR News*, Dec. 1994, vol. 3, Issue 10, pp. 4, 8, 12.

Explore Litigation Insights

Docket Alarm provides insights to develop a more informed litigation strategy and the peace of mind of knowing you're on top of things.

Real-Time Litigation Alerts



Keep your litigation team up-to-date with **real-time alerts** and advanced team management tools built for the enterprise, all while greatly reducing PACER spend.

Our comprehensive service means we can handle Federal, State, and Administrative courts across the country.

Advanced Docket Research



With over 230 million records, Docket Alarm's cloud-native docket research platform finds what other services can't. Coverage includes Federal, State, plus PTAB, TTAB, ITC and NLRB decisions, all in one place.

Identify arguments that have been successful in the past with full text, pinpoint searching. Link to case law cited within any court document via Fastcase.

Analytics At Your Fingertips



Learn what happened the last time a particular judge, opposing counsel or company faced cases similar to yours.

Advanced out-of-the-box PTAB and TTAB analytics are always at your fingertips.

API

Docket Alarm offers a powerful API (application programming interface) to developers that want to integrate case filings into their apps.

LAW FIRMS

Build custom dashboards for your attorneys and clients with live data direct from the court.

Automate many repetitive legal tasks like conflict checks, document management, and marketing.

FINANCIAL INSTITUTIONS

Litigation and bankruptcy checks for companies and debtors.

E-DISCOVERY AND LEGAL VENDORS

Sync your system to PACER to automate legal marketing.